

**WIRE COLOR SCHEME**  
 BLACK - LINE VOLTAGE  
 RED - AC CONTROL  
 WHITE - AC GROUNDED  
 WHITE - CIRCUIT CONDUCTOR  
 BLUE - DC CONTROL  
 GREEN - CHASSIS GROUND

\* ALL CONTROL WIRES ARE BLUE EXCEPT WHERE NOTED.

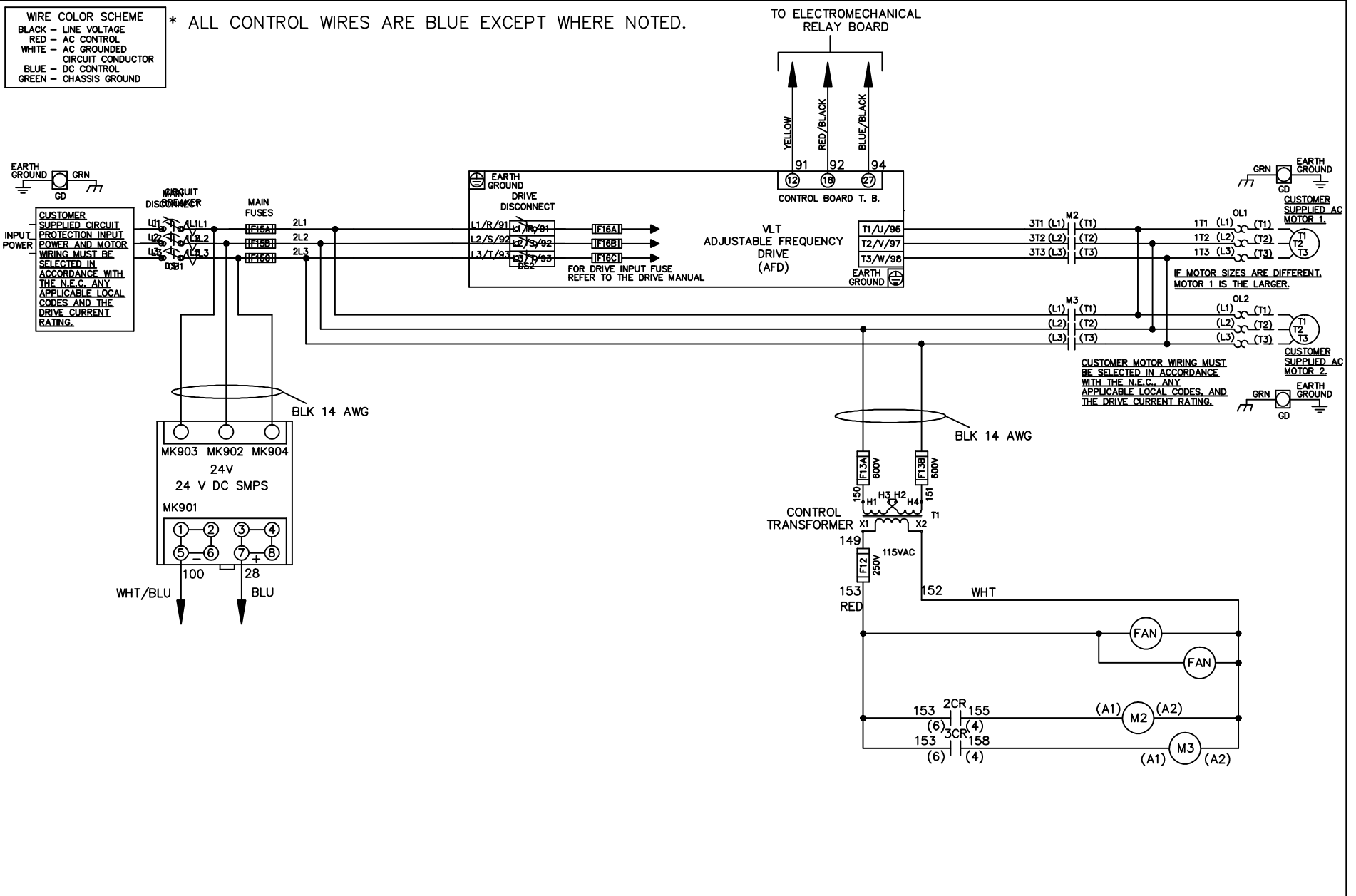

- NOTICE -

THIS DOCUMENT CONTAINS PROPRIETARY INFORMATION OF DANFOSS DRIVES. IT IS LOANED BY DANFOSS DRIVES SUBJECT TO THE CONDITIONS THAT IT AND THE INFORMATION EMBODIED THEREIN SHALL BE USED ONLY FOR RECORD AND REFERENCE PURPOSES, SHALL NOT BE USED OR CAUSED TO BE USED IN ANY WAY PREJUDICIAL TO THE INTERESTS OF DANFOSS DRIVES, SHALL NOT BE REPRODUCED OR COPIED IN WHOLE OR IN PART, OR DISCLOSED TO ANYONE WITHOUT THE DIRECT WRITTEN PERMISSION OF DANFOSS DRIVES AND SHALL BE RETURNED UPON REQUEST.

DRN JNW  
 2/14/07  
 APR

NAME460 VOLT,2C,CB & DRIVE DISC  
 ,MAIN FUSE,EMB1,FRAME D1-D2  
 ,NO REACTOR & DVDT,DUAL MTR

MODEL VLT  
 PAGE 1 OF 2  
 SIZE A  
 DWG NO. 174U2996



REV	ECN	DATE
-----	-----	------

REV	ECN	DATE

CONTACT SEQUENCE CHART FOR S1  
X INDICATES CONTACT CLOSED

POSITION	DRIVE	OFF	BYPASS
CONTACT			
13-14			X
23-24	X		

**NOTICE**  
THIS DOCUMENT CONTAINS PROPRIETARY INFORMATION OF DANFOSS DRIVES. IT IS LOANED BY DANFOSS DRIVES SUBJECT TO THE CONDITIONS THAT IT AND THE INFORMATION EMBODIED THEREIN SHALL BE USED ONLY FOR RECORD AND REFERENCE PURPOSES. SHALL NOT BE USED OR CAUSED TO BE USED IN ANY WAY PREJUDICIAL TO THE INTERESTS OF DANFOSS DRIVES. SHALL NOT BE REPRODUCED OR COPIED IN WHOLE OR IN PART, OR DISCLOSED TO ANYONE WITHOUT THE DIRECT WRITTEN PERMISSION OF DANFOSS DRIVES AND SHALL BE RETURNED UPON REQUEST.

DRN JNW  
2/14/07  
APR

NAME 460 VOLT, 2C, CB & DRIVE DISC  
, MAIN FUSE, EMB1, FRAME D1-D2  
, NO REACTOR & DVDI, DUAL MTR

MODEL VLT  
PAGE 2 OF 2  
SIZE A  
DWG NO. 174U2996

