

WIRE COLOR SCHEME	
BLACK	- LINE VOLTAGE
RED	- AC CONTROL
WHITE	- AC GROUNDED CIRCUIT CONDUCTOR
BLUE	- DC CONTROL
WHT/BLU	- DC CONTROL COMMON
GREEN	- CHASSIS GROUND

* ALL CONTROL WIRES ARE BLUE EXCEPT WHERE NOTED. TO ELECTROMECHANICAL RELAY BOARD

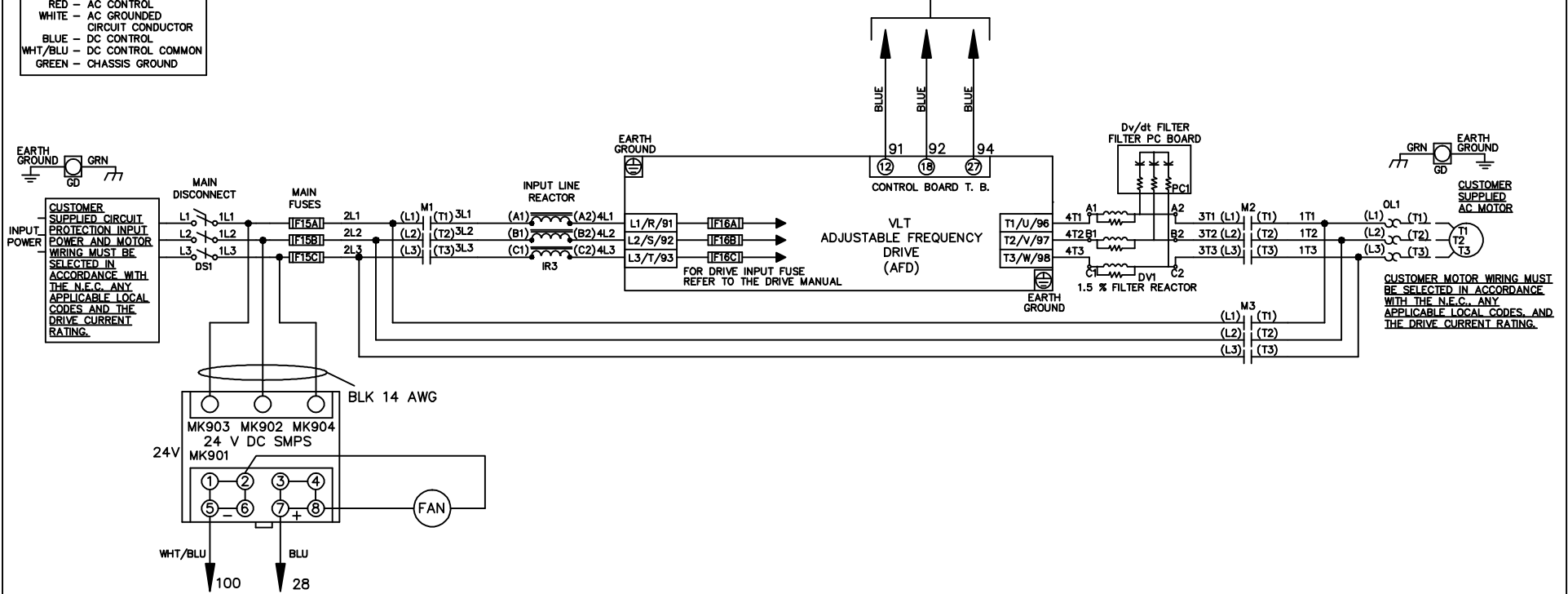

- NOTICE -			DRN JNW 2/14/07		NAME 208-600VOLT, 3C, MAIN DISC , MAIN FUSE, EMB1, FRAME C1N12 , REACTOR & DVDT, SINGLE MTR		<i>Danfoss</i>	
A	SP08061	10/08	APR		MODEL	PAGE 1 OF 2	SIZE A	DWG NO. 174U3591
REV	ECN	DATE	THIS DOCUMENT CONTAINS PROPRIETARY INFORMATION OF DANFOSS DRIVES. IT IS LOANED BY DANFOSS DRIVES SUBJECT TO THE CONDITIONS THAT IT AND THE INFORMATION EMBODIED THEREIN SHALL BE USED ONLY FOR RECORD AND REFERENCE PURPOSES, SHALL NOT BE USED OR CAUSED TO BE USED IN ANY WAY PREJUDICIAL TO THE INTERESTS OF DANFOSS DRIVES, SHALL NOT BE REPRODUCED OR COPIED IN WHOLE OR IN PART, OR DISCLOSED TO ANYONE WITHOUT THE DIRECT WRITTEN PERMISSION OF DANFOSS DRIVES AND SHALL BE RETURNED UPON REQUEST.					

REV	ECON	DATE
A	SP08066	10/08

POSITION	DRIVE	OFF	BYPASS	TEST
1-2	X			X
3-4			X	X
5-6				X
7-8				X

CONTACT SEQUENCE CHART FOR S1
X INDICATES CONTACT CLOSED

NOTICE
THIS DOCUMENT CONTAINS PROPRIETARY INFORMATION OF DANFOSS DRIVES. IT IS LOANED BY DANFOSS DRIVES SUBJECT TO THE CONDITIONS THAT IT AND THE INFORMATION EMBODIED THEREIN SHALL BE USED ONLY FOR RECORD AND REFERENCE PURPOSES, SHALL NOT BE USED OR CAUSED TO BE USED IN ANY WAY PREJUDICIAL TO THE INTERESTS OF DANFOSS DRIVES, SHALL NOT BE REPRODUCED OR COPIED IN WHOLE OR IN PART, OR DISCLOSED TO ANYONE WITHOUT THE DIRECT WRITTEN PERMISSION OF DANFOSS DRIVES AND SHALL BE RETURNED UPON REQUEST.

DRN JNW
2/14/07
APR

NAME 208-600VOLT, 3C, MAIN DISC
, MAIN FUSE, EMB1, FRAME C1N12
, REACTOR & DVD1, SINGLE MTR
MODEL
PAGE 2 OF 2
SIZE A
DWG NO. 174U3591

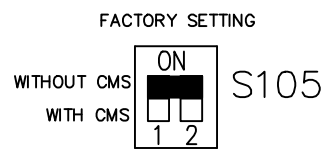
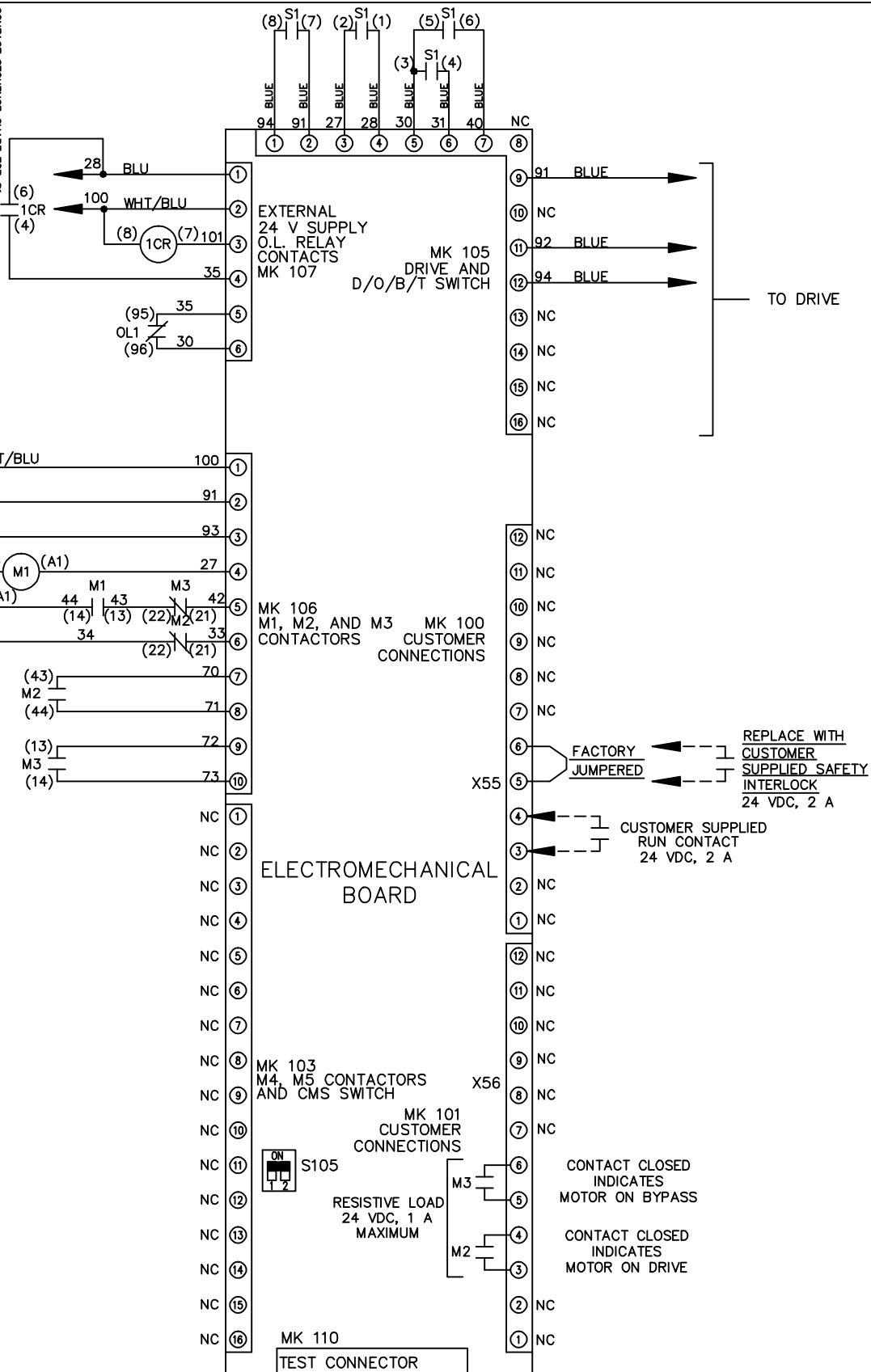

CUSTOMER CONNECTIONS X55, X56
CLASS 2 POWER SOURCE
REQUIRED FOR FIELD CONNECTION
USE CLASS 1 CONDUCTORS
CONDUCTOR SIZE 28-14 AWG