

\* ALL CONTROL WIRES ARE BLUE EXCEPT WHERE NOTED.

WIRE COLOR SCHEME	
BLACK	- LINE VOLTAGE
RED	- AC CONTROL
WHITE	- AC GROUNDED CIRCUIT CONDUCTOR
BLUE	- DC CONTROL
WHT/BLU	- DC CONTROL COMMON
GREEN	- CHASSIS GROUND

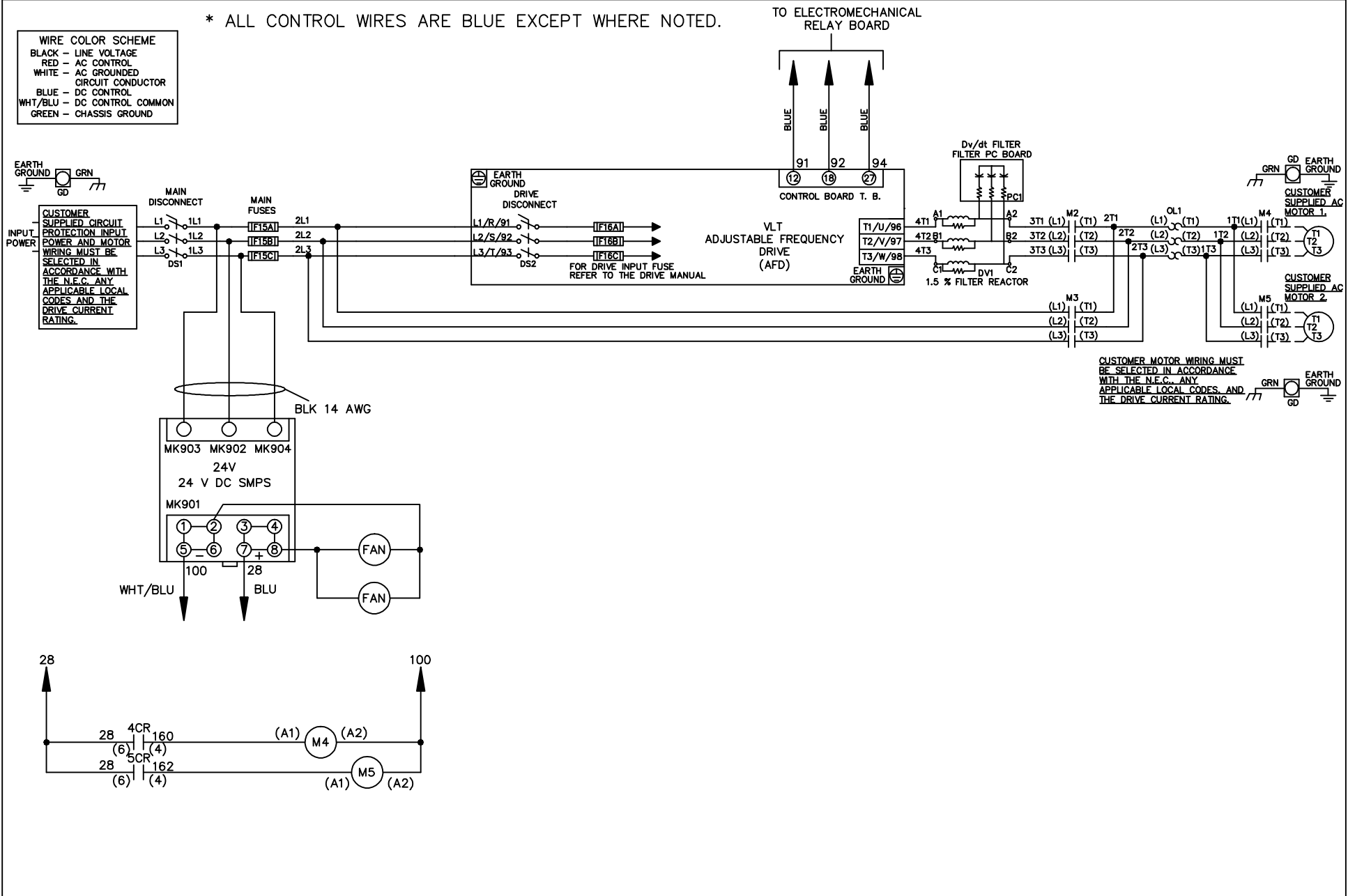

CUSTOMER MOTOR WIRING MUST BE SELECTED IN ACCORDANCE WITH THE N.E.C. ANY APPLICABLE LOCAL CODES AND THE DRIVE CURRENT RATING.

			-NOTICE-		DRN JNW 2/14/07		NAME 208-600VOLT, 2C, MAIN & DRIVE DISC , MAIN FUSE, EMB1, FRAME C1N12 , DVDT, CMS		THE TRANE COMPANY A DIVISION OF AMERICAN STANDARD INC.		
A	SP08061	10/08	THIS DRAWING IS PROPRIETARY AND SHALL NOT BE COPIED OR ITS CONTENTS DISCLOSED TO OUTSIDE PARTIES WITHOUT THE WRITTEN CONSENT OF THE TRANE COMPANY			APR	MODEL	PAGE 1 OF 2	SIZE A	DWG NO.	174U5373
REV	ECN	DATE									

REV	ECN	DATE
A	SP08066	10/08

THIS DRAWING IS PROPRIETARY AND SHALL NOT BE COPIED OR ITS CONTENTS DISCLOSED TO OUTSIDE PARTIES WITHOUT THE WRITTEN CONSENT OF THE TRANE COMPANY

DRN JNW  
2/14/07  
APR

NAME 208-600VOLT, 2C, MAIN&DRIVE DISC  
, MAIN FUSE, EMB1, FRAME C1N12  
, DVD1, CMS

THE TRANE COMPANY  
A DIVISION OF  
AMERICAN STANDARD INC.

CONTACT SEQUENCE CHART FOR S1  
X INDICATES CONTACT CLOSED

CONTRACT POSITION	DRIVE	OFF	BYPASS
13-14			X
23-24	X		

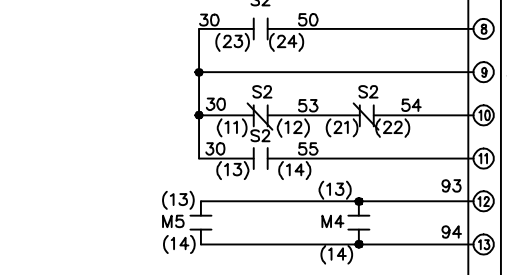
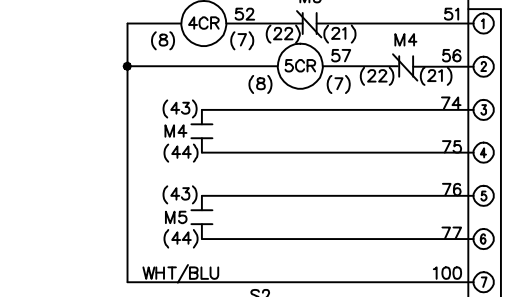
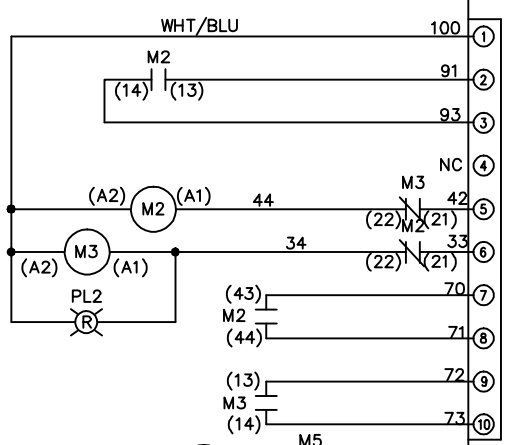
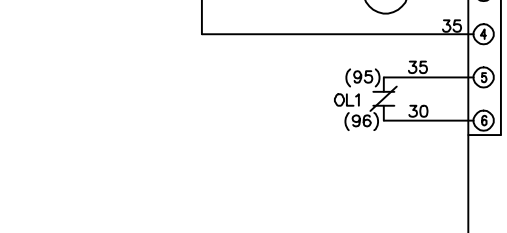

CONTACT SEQUENCE CHART FOR S2  
X INDICATES CONTACT CLOSED

CONTRACT POSITION	MOTOR 1	AUTO	MOTOR 2
11-12	X	X	
13-14			X
21-22		X	X
23-24	X		

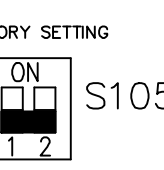
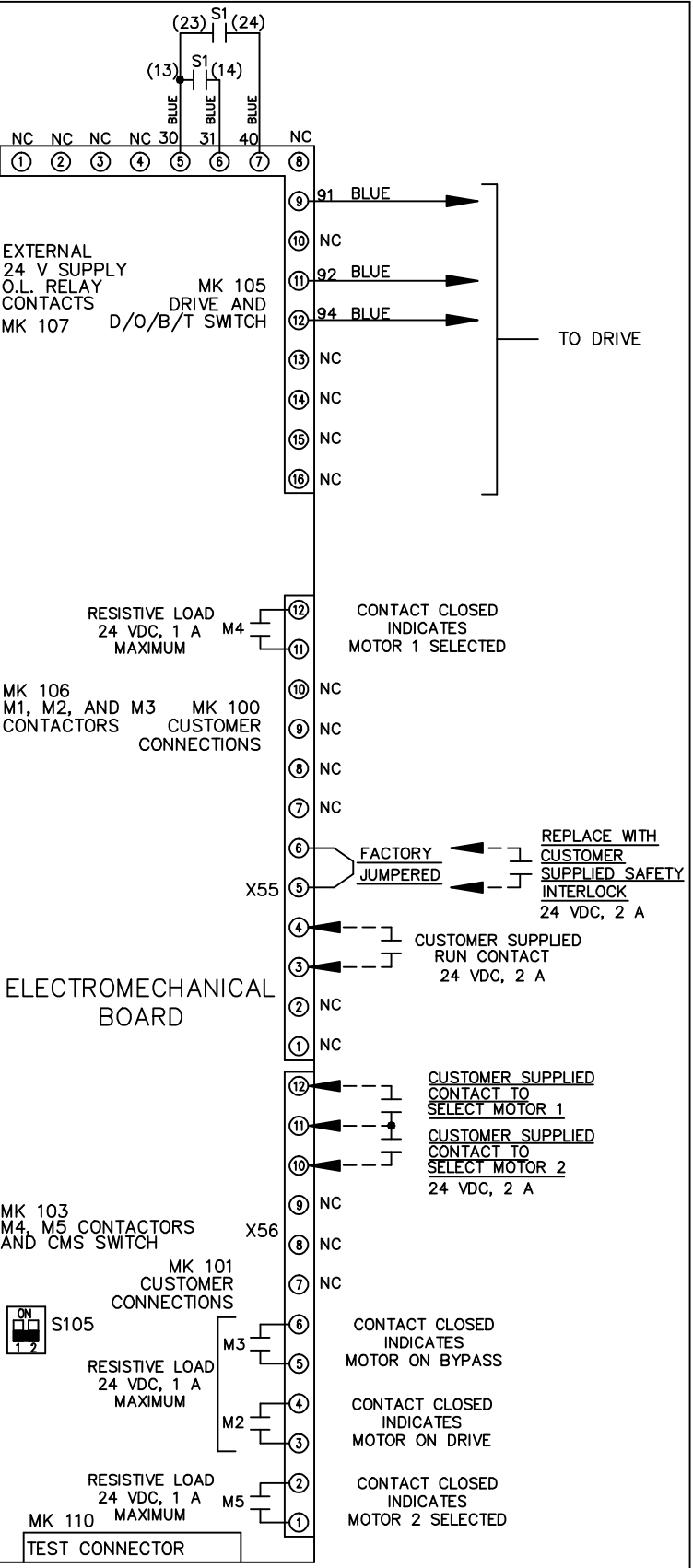

CUSTOMER CONNECTIONS X55, X56  
CLASS 2 POWER SOURCE  
REQUIRED FOR FIELD CONNECTION  
USE CLASS 1 CONDUCTORS  
CONDUCTOR SIZE 28-14 AWG