

WIRE COLOR SCHEME
 BLACK - LINE VOLTAGE
 RED - AC CONTROL
 WHITE - AC GROUNDED
 CIRCUIT CONDUCTOR
 BLUE - DC CONTROL
 WHT/BLU - DC CONTROL COMMON
 GREEN - CHASSIS GROUND

* ALL CONTROL WIRES ARE BLUE EXCEPT WHERE NOTED. TO ELECTROMECHANICAL RELAY BOARD

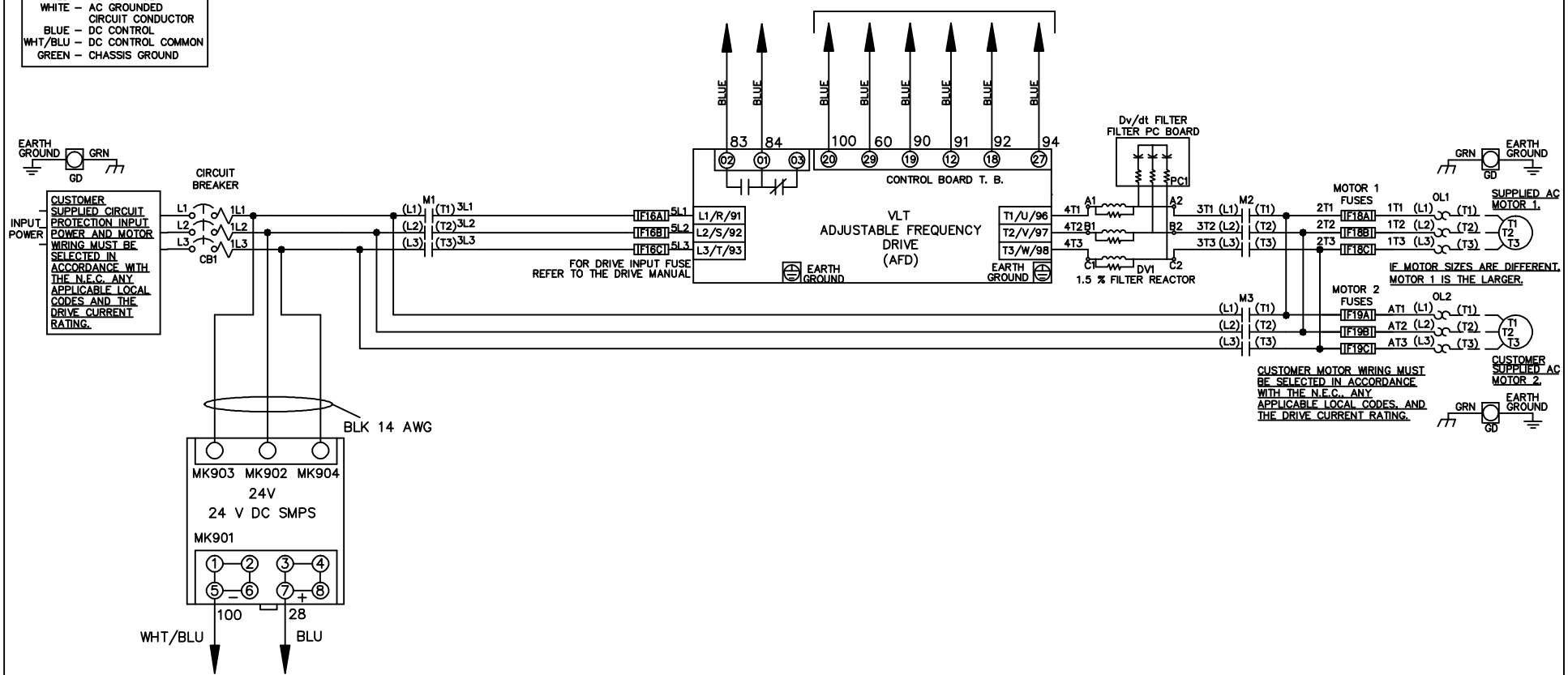

			-NOTICE-		DRN JNW 2/14/07		NAME 208-600VOLT,3C,CB ,DRIVE FUSE,EMB2,FRAME A2-A3 ,DVDT,DUAL MTR		THE TRANE COMPANY A DIVISION OF AMERICAN STANDARD INC.	
A	SP08061	10/08	THIS DRAWING IS PROPRIETARY AND SHALL NOT BE COPIED OR ITS CONTENTS DISCLOSED TO OUTSIDE PARTIES WITHOUT THE WRITTEN CONSENT OF THE TRANE COMPANY			APR	MODEL	PAGE 1 OF 2	SIZE A	DWG NO. 174U7764
REV	ECN	DATE								

REV	ECN	DATE			
A	SP08066	10/08			
THIS DRAWING IS PROPRIETARY AND SHALL NOT BE COPIED OR ITS CONTENTS DISCLOSED TO OUTSIDE PARTIES WITHOUT THE WRITTEN CONSENT OF THE TRANE COMPANY					
-NOTICE-					
DRN	JNW	2/14/07	APR		
MODEL	NAME 208-600VOLT,3C,CB ,DRIVE FUSE,EMB2,FRAME A2-A3 ,DVDI,DUAL MTR				
PAGE	2	OF	2	SIZE	A
DWG	NO. 174U7764				
THE TRANE COMPANY A DIVISION OF AMERICAN STANDARD INC.					

CONTACT POSITION	DRIVE	OFF	BYPASS	TEST
1-2	X			X
3-4			X	X
5-6	X			X
7-8				

CONTACT SEQUENCE CHART FOR S1
 X INDICATES CONTACT CLOSED

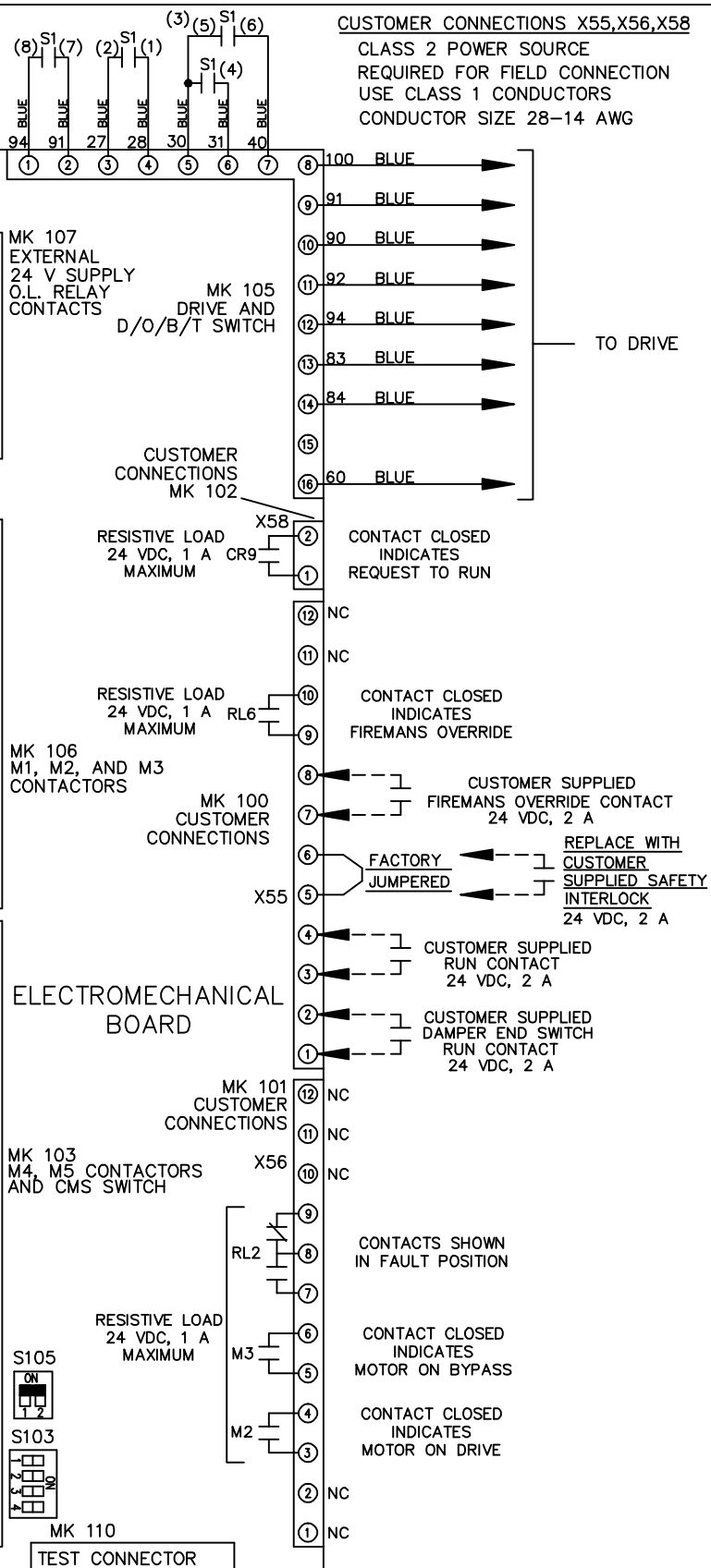
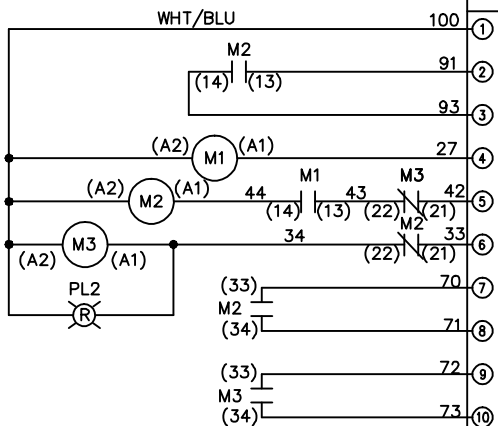

CUSTOMER CONNECTIONS X55,X56,X58
 CLASS 2 POWER SOURCE
 REQUIRED FOR FIELD CONNECTION
 USE CLASS 1 CONDUCTORS
 CONDUCTOR SIZE 28-14 AWG

