

WIRE COLOR SCHEME
 BLACK - LINE VOLTAGE
 RED - AC CONTROL
 WHITE - AC GROUNDED
 CIRCUIT CONDUCTOR
 BLUE - DC CONTROL
 WHT/BLU - DC CONTROL COMMON
 GREEN - CHASSIS GROUND

* ALL CONTROL WIRES ARE BLUE EXCEPT WHERE NOTED. TO ELECTROMECHANICAL RELAY BOARD

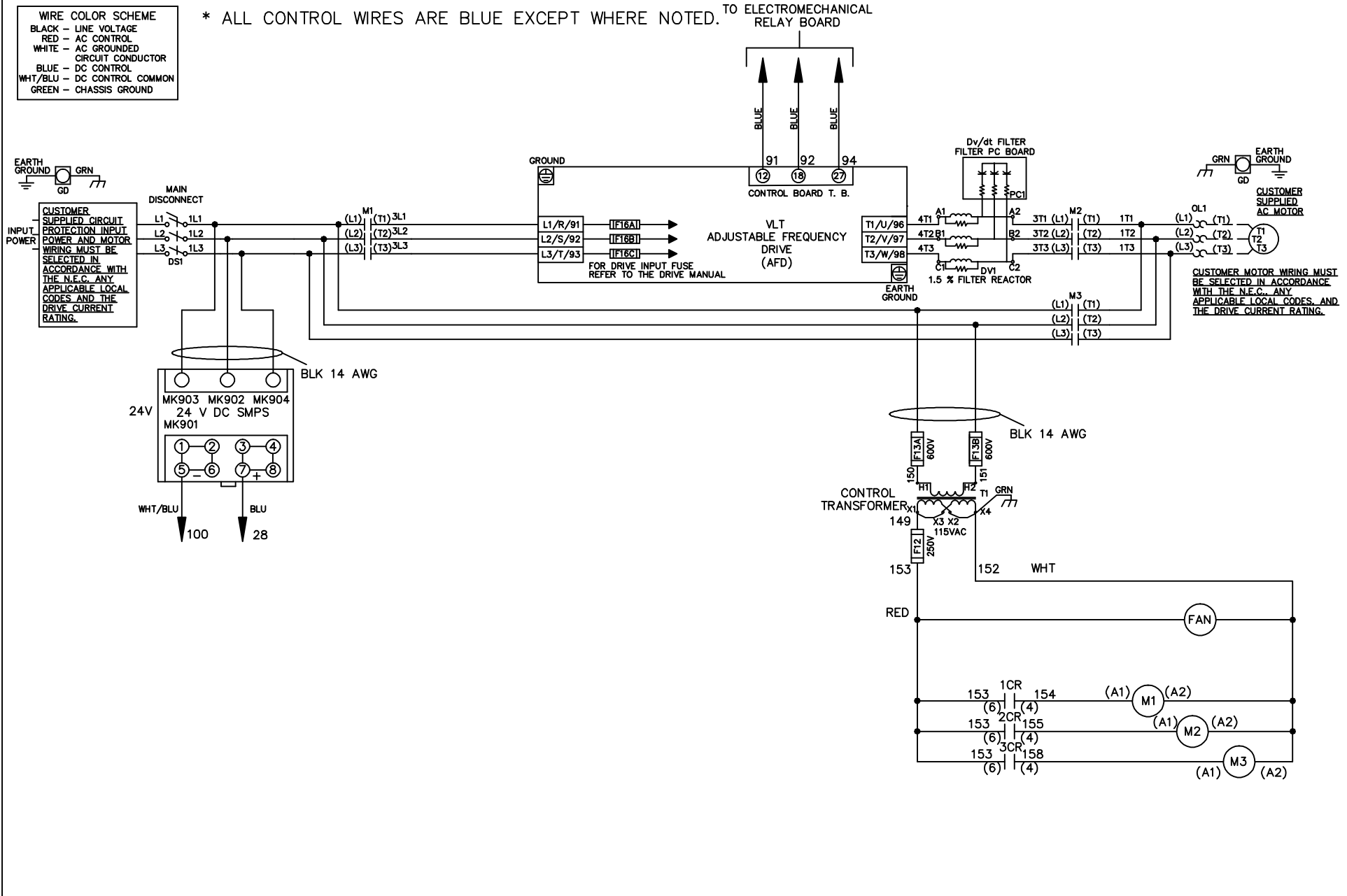

-NOTICE-

THIS DRAWING IS PROPRIETARY AND SHALL NOT BE COPIED OR ITS CONTENTS DISCLOSED TO OUTSIDE PARTIES WITHOUT THE WRITTEN CONSENT OF THE TRANE COMPANY

DRN JNW
 2/14/07

APR

NAME 600 VOLT,3C,MAIN DISC
 ,DRIVE FUSE,EMB1,FRAME D1-D2
 ,DVDT,SINGLE MTR

MODEL

PAGE 1 OF 2

SIZE A

DWG NO.

THE TRANE COMPANY
 A DIVISION OF
 AMERICAN STANDARD INC.

174U8874

A	SP08061	10/08
REV	ECN	DATE

REV	ECON	DATE			
A	SP08066	10/08			
THIS DRAWING IS PROPRIETARY AND SHALL NOT BE COPIED OR ITS CONTENTS DISCLOSED TO OUTSIDE PARTIES WITHOUT THE WRITTEN CONSENT OF THE TRANE COMPANY					
DRN JNW 2/14/07			NAME 600 VOLT, 3C, MAIN DISC , DRIVE FUSE, EMB1, FRAME D1-D2 , DVD1, SINGLE MTR		
MODEL PAGE 2 OF 2			SIZE A DWG NO. 174U8874		
THE TRANE COMPANY A DIVISION OF AMERICAN STANDARD INC.					

CONTACT SEQUENCE CHART FOR S1
X INDICATES CONTACT CLOSED

CONTACT	POSITION	DRIVE	OFF	BYPASS	TEST
1-2		X			X
3-4				X	X
5-6		X			X
7-8					X

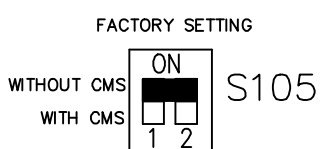
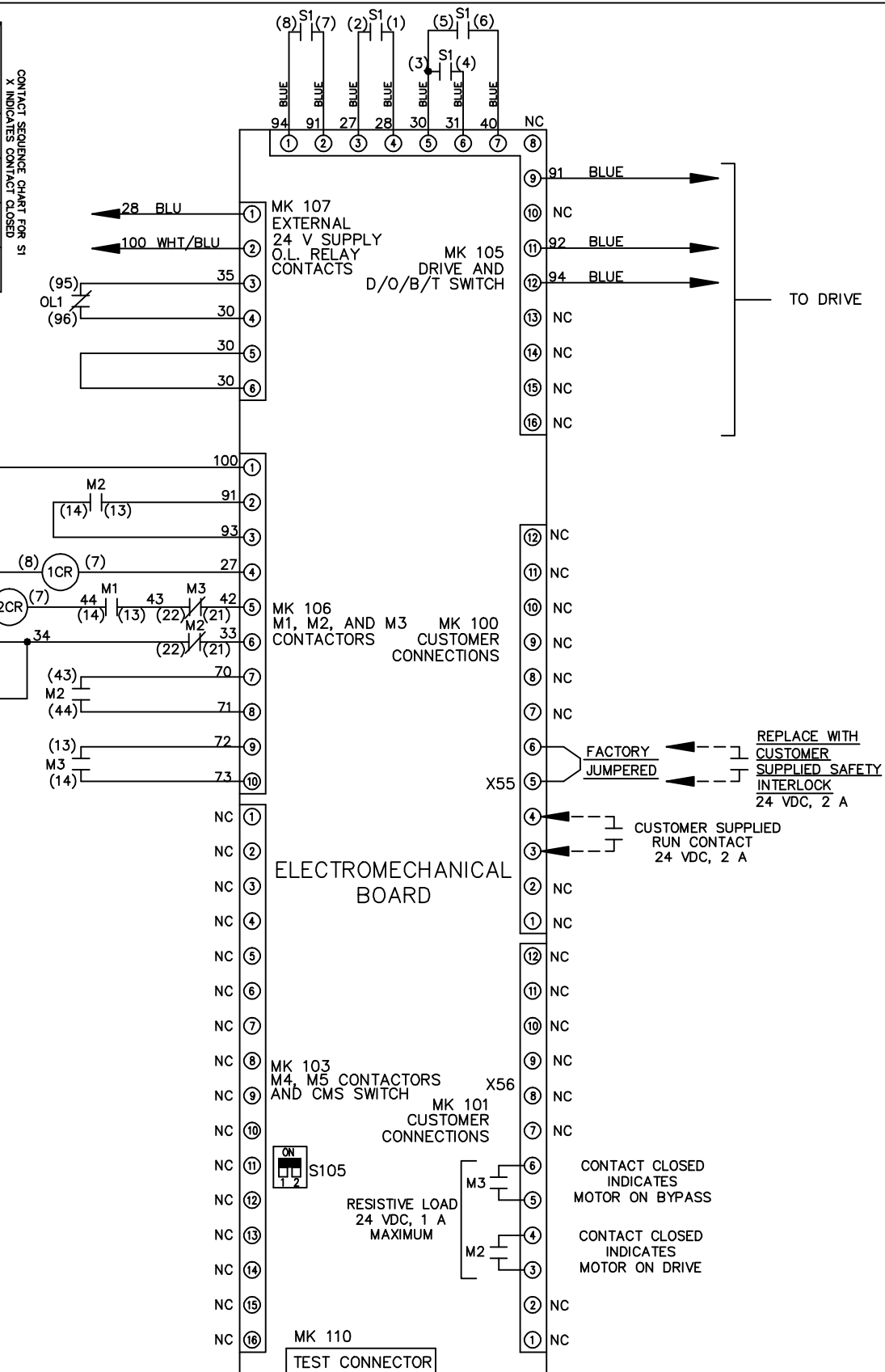

CUSTOMER CONNECTIONS X55, X56
 CLASS 2 POWER SOURCE
 REQUIRED FOR FIELD CONNECTION
 USE CLASS 1 CONDUCTORS
 CONDUCTOR SIZE 28-14 AWG