

■ Warnings and Safety Precautions	2	■ Databytes	
■ Cable Specifications / Connection		Parameter bytes	6
Shielding and Grounding	3	Commands and replies (AK)	6
Cable Cross-section	4	Parameter number (PNU)	7
Bus Connection	4	Index (IND)	7
Bus Termination	4	Parameter value (PWE)	7
Switches 1-4	4	Process bytes (PCD)	8
■ VLT Dialog 5000 Option		■ VLT Standard Control Word	8
RS 232/RS 485 Converter	4	■ VLT Standard Status Word	10
■ Serial Bus	5	■ Profidrive Control Word	11
■ Telegram communication		■ Profidrive Status Word	12
Control and reply telegrams	5	■ Bus Reference Value	13
Broadcast	5	■ Telegram Examples	13
Contents of a byte	5	■ Serial Communication Parameter Group	16
■ Telegram build-up		■ Factory Settings Table	27
Telegram length	5		
VLT address	5		
Data control byte	6		

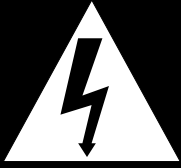

WARNING

The VLT Adjustable Frequency Drive contains dangerous voltages when connected to line voltage. After disconnecting from the line wait at least 15 minutes before touching any electrical components. Only a competent electrician should carry out the electrical installation. Improper installation of the motor or the VLT may cause equipment failure, serious injury or death. Follow this manual and National Electrical Codes (NEC®) and local safety codes.

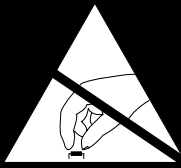

WARNING

Electrostatic Precaution; Electrostatic discharge (ESD). Many electronic components are sensitive to static electricity. Voltages so low that they cannot be felt, seen or heard, can reduce the life, affect performance, or completely destroy sensitive electronic components. When performing service, proper ESD equipment should be used to prevent possible damage from occurring.



It is the responsibility of the user or the person installing the VLT to provide proper grounding, as well as motor overload and branch circuit protection according to the National Electrical Code (NEC®) and local codes.

■ Safety Precautions

1. The VLT adjustable frequency drive must be disconnected from the AC line if repair work is to be carried out. After the AC supply has been disconnected be sure the necessary time has passed before removing motor and line terminal plugs.
2. The "Stop/Reset" key on the local control panel of the VLT adjustable frequency drive DOES NOT disconnect the equipment from the AC line and is NOT to be used as a safety switch.
3. The installer must supply correct protective grounding of the equipment, the user must be protected against supply voltage, and the motor must be protected against overload in accordance with National Electrical Code and local codes.
4. To avoid potential shock hazard when servicing a motor or adjustable frequency drives, remove all power to all drives having wiring that shares any conduit to be worked on. If that is not possible, remove power to the drive and ground the motor wires at the drive. When the work has been completed, remove the grounds before reapplying power to the drive. In general, a conduit should not contain unshielded power conductors for more than three PWM operated motors.
5. The ground leakage currents are higher than 3.5 mA.

6. The Electronic Thermal Relay (ETR) in UL/cUL listed VLT's provides class 20 motor overload protection in accordance with the NEC in single motor applications, when parameter 128 is set for "TRIP" and parameter 105 is set for nominal motor rated (nameplate) current.

Protection against motor overload is NOT included in the factory setting. If this function is desired, set parameter 128 to data value *ETR trip* or data value *ETR warning*.

Note: The function is initialized at 1.16 x rated motor current.

■ Warning against unintended start

1. The motor can be brought to a stop by means of digital commands, bus commands, references or a local stop, while the adjustable frequency drive is connected to the AC line.

These stop functions are NOT sufficient to ensure that no unintended start occurs and should NOT be used for personal safety considerations.

2. While parameters are being changed, the motor may start. Consequently, the stop key "Stop/Reset" must always be activated, following which data can be modified.
3. A motor that has been stopped may start if faults occur in the electronics of the VLT adjustable frequency drive, or if a temporary overload or a fault in the AC line supply or the motor connection ceases.

■ Cable Specifications / Connection

Grounding of Shielded/Armored Control Cables

Generally speaking, control cables must be shielded/armored and the shield must be connected by means of a cable clamp at both ends to the metal cabinet of the unit. The drawings indicate how correct grounding is to be carried out.

NOTE:

DO NOT use twisted cable ends (pigtailed), since these increase the shield impedance at high frequencies.

Correct Grounding

Control cables and cables for serial communication must be fitted with cable clamps at both ends to ensure the best possible electrical contact.

Protection with respect to ground potential between PLC and VLT

If the ground potential between the VLT adjustable frequency drive and the PLC (etc.) is different, electrical noise may occur that will disturb the whole system. This problem can be solved by fitting an equalizing cable, to be placed next to the control cable. Minimum cable cross-section: 10 mm².

For 50/60 Hz Ground Loops

If very long control cables are used, 50/60 Hz ground loops may occur that will disturb the whole system. This problem can be solved by connecting one end of the shield to ground via a 100nF capacitor (keeping leads short).

Cables for Serial Communication

Low-frequency noise currents between two VLT adjustable frequency drives can be eliminated by connecting one end of the shield to terminal 61. This terminal is connected to ground via an internal RC link. It is recommended to use twisted-pair cables to reduce the differential mode interference between the conductors.

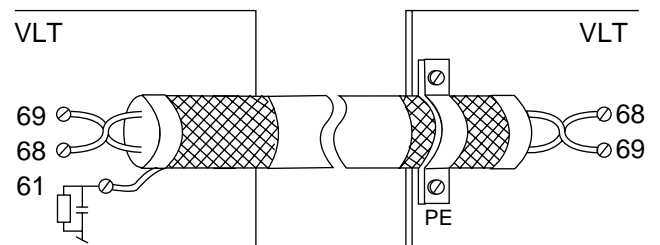
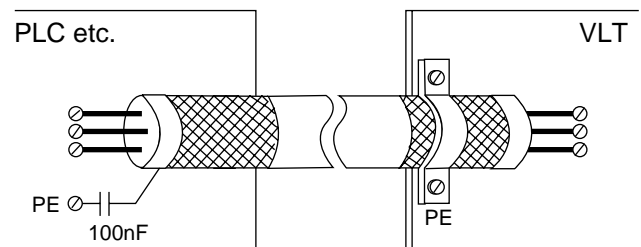
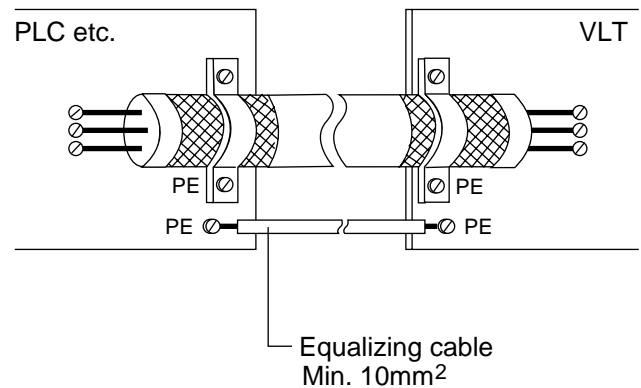
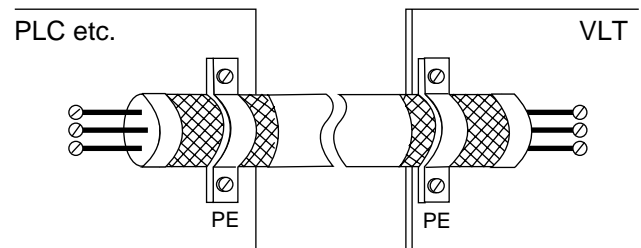
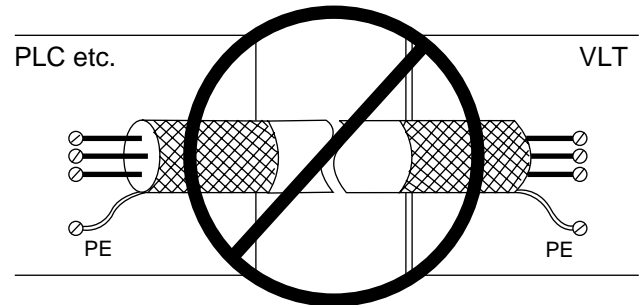

Cable Cross-section

Maximum cable cross-section for serial communication is 16 AWG (1.5 mm²).

Bus Connection

The serial bus connection in accordance with the RS 485 (2 conductor) norm is connected to terminals 68/69 of the adjustable frequency drive (signals P and N). Signal P is the positive potential (TX+, RX+), while signal N is the negative potential (TX-, RX-).

If more than one adjustable frequency drive is to be connected to a given master, use parallel connections.

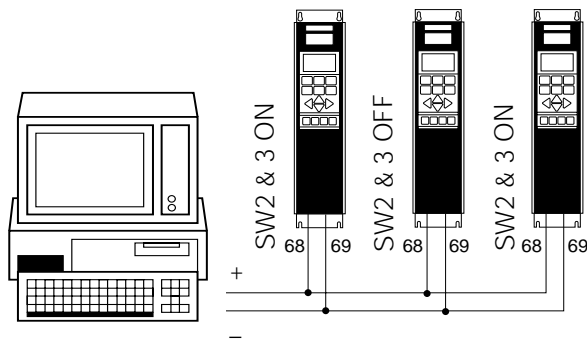

Bus Termination

The RS 485 Bus must be properly terminated. Switches 2 and 3 are provided to allow access to internal termination resistors.

Terminate only the first and the last unit connected to the bus by setting switches 2 & 3 ON.

Switches 1-4

The dip switch located on the control card is used for serial communication terminals 68 and 69.

Switch 1 has no function.

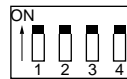

Switch position shown in the factory setting.

Switches 2 and 3 are used for terminating an RS 485 interface, serial communication.

Switch 4 is used for separating the common potential for the internal 24 VDC supply from the common potential of the external 24 VDC supply.

NOTE:

Please note that when Switch 4 is in position "OFF", the external 24 VDC supply is galvanically isolated from the VLT adjustable frequency drive. See VLT 5000 Series Instruction Manual 175R5271 for further details.

In order to avoid potential equalizing currents in the shield, the cable shield can be grounded via terminal 61, which is connected to the frame via an RC-link.

■ VLT® Dialog 5000 Option 176F1700/1704

Option Kit consists of:

- 175Z0903 - VLT Dialog Software Basic Module
- 176F1701 - RS 485 Cable (10 feet)
- 176F1702 - RS 232/RS 485 Converter
- 176F1703 - RS 232 Cable adaptor (6 inch)
- 175Z0908 - (1704 only) Template Module
- 175Z0909 - (1704 only) Logging Module

Danfoss can supply all items necessary to allow a PC to communicate with a VLT 5000. This includes Cables, Connectors, Converter Module as well as Windows™ software which allows programming, control and monitoring of the VLT 5000.

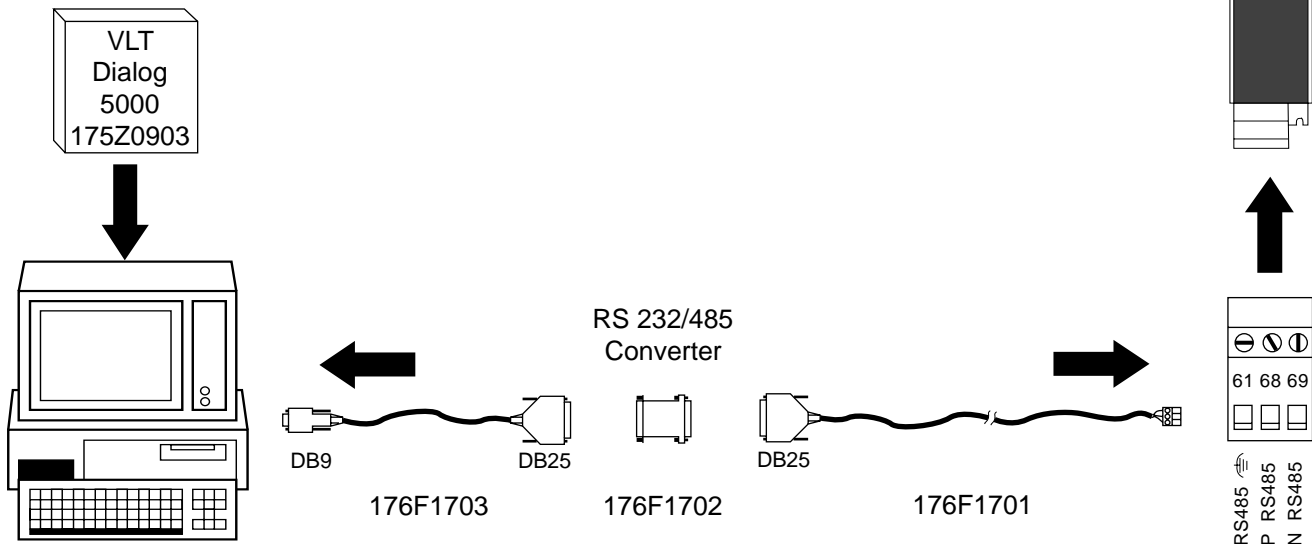

Serial bus

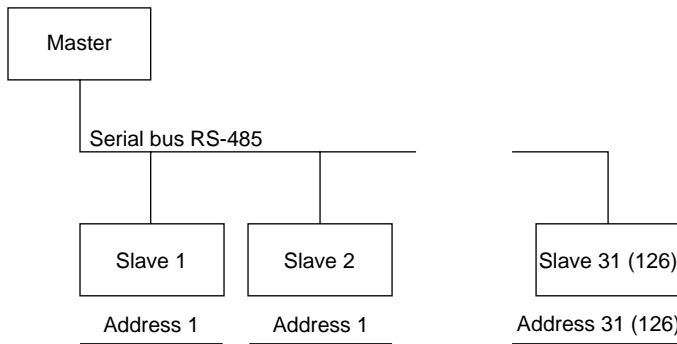

Telegram communication

Control and reply telegrams

The VLT 5000 Series Control Card is equipped with an RS-485 serial communication port which can be used for control, programming, and indication of unit status. The communication protocol is a master/slave system, where the master (PC or PLC) initiates all communication. A maximum of 31 slaves (VLT 5000) can be connected to one master, unless a repeater is used (see *VLT address [ADR]* for further details).

The master continuously sends control telegrams addressed to the slaves and awaits reply telegrams. The maximum slave response time is 50 ms. Only a slave that has received a faultless telegram addressed to that slave will respond by sending a reply message. A slave will not send a reply telegram if these conditions have not been fulfilled, or if it receives a Broadcast telegram sent to all slaves.

Broadcast

A master can send a control telegram which will be accepted by all VLT slaves at the same time. A broadcast telegram is specified by configuring the (ADR) byte according to the address format selected. A VLT adjustable frequency drive will not reply to a broadcast telegram.

Contents of a byte

Previous VLT serial communication protocols transmitted databytes in 7-bit ASCII format. The VLT 5000 protocol transmits 8-bit hexadecimal words. Each transmitted byte begins with a start bit, followed by 8 databits. After the databits there is an even parity bit followed by a stop bit. In setting up the serial communication port, select 9600 baud, 8 databits, even parity, 1 stop bit (slower baud rates possible, see Parameter 500).

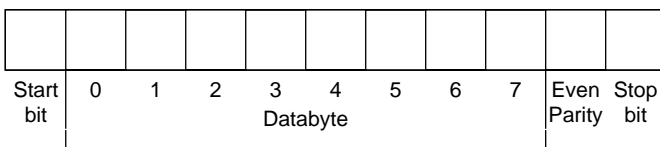

Telegram build-up

Each telegram begins with a startbyte (STX)=02 Hex, followed by a byte that gives the telegram length (LGE) and a byte that gives the address (ADR). Then follows a number of databytes (length depends on the telegram type). The telegram ends with a data control byte (BCC) used as a check sum.

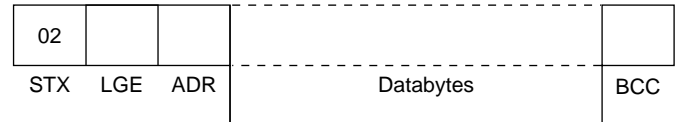

Telegram length (LGE)

The telegram length is equal to the number of databytes plus address byte (ADR) plus data control byte (BCC). There are two telegram types described under *Databytes*.

Telegrams with 4 databytes (short form) have a length of: LGE = 4 + 1 + 1 = 6 bytes, 06 Hex

Telegrams with 12 databytes (long form) have a length of: LGE = 12 + 1 + 1 = 14 bytes, 0E Hex

VLT address (ADR)

Two different address formats are used. The Danfoss format allows specification of bus address up to 126. The Siemens USS address format limits bus addresses to 31.

1. Danfoss format (VLT parameter 512 = DANFOSS), factory default setting:

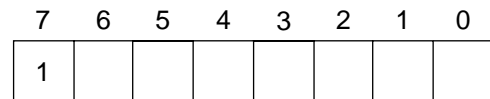

Bit 7 = 1

Bits 0 - 6 = VLT address 1 - 126, (0 = Broadcast).

Address 01 → ADR = 81 Hex.

2. Siemens USS protocol address format (VLT parameter 512 = PROFIDRIVE):

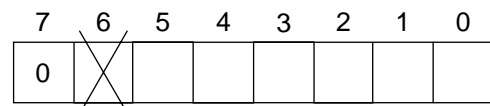

Bit 7 = 0

Bit 6 is not used

Bit 5 = 1: Broadcast, address bits (0-4) are not used

Bit 5 = 0: No Broadcast

Bit 0 - 4 = VLT address 1 - 31

Address 01 → ADR = 01 Hex.

Note: If more than 31 slaves (VLT 5000) are connected to a master, a repeater must be used.

The slave sends the address byte back to the master in the reply telegram in unchanged form. Slaves will not reply to broadcast telegrams.

Data control byte (BCC)

The data control byte acts as a checksum byte for the telegram. To insure the validity of a telegram, the VLT checks for the following:

- a. Even parity
- b. Calculated BCC value matches the BCC byte in received telegram.

This value must be calculated for each telegram the master sends. The (BCC) data control byte value is calculated by performing a logical exclusive OR operation on all bytes in the telegram (STX to PCD2). The final result is converted into hexadecimal format. This value becomes the telegram's (BCC) data control byte.

BCC calculation example for a sample short form telegram:

STX	LGE	ADR	PCD1		PCD2		BCC
02	06	81	04	FC	20	00	5D

	02	0000	0010
	06	0000	0110
	81	1000	0001
	04	0000	0100
	FC	1111	1100
	20	0010	0000
	00	0000	0000
XOR	5D	0101	1101

■ Databytes

The block of databytes are divided into two groups.

1. Parameter bytes: used for transferring VLT parameters between master and slave
2. Process bytes, used for:
 - a. Control word and reference value (from master to slave)
 - b. Status word and percent output frequency (from slave to master)

This structure applies to both control telegram (master → slave) and the reply telegram (slave → master).

PKE	IND	PWE _{HIGH}	PWE _{LOW}	PCD1	PCD2
Parameter bytes				Process bytes	

The Master can send two types of telegrams:

- (long form) 12 byte built-up as shown above, using both Parameter and Process bytes
- (short form) 4 byte build-up, using only Process bytes.

1. Parameter bytes

Parameter bytes contain all information regarding the reading and writing of VLT parameters.

PKE: This is divided into two parts, AK and PNU.

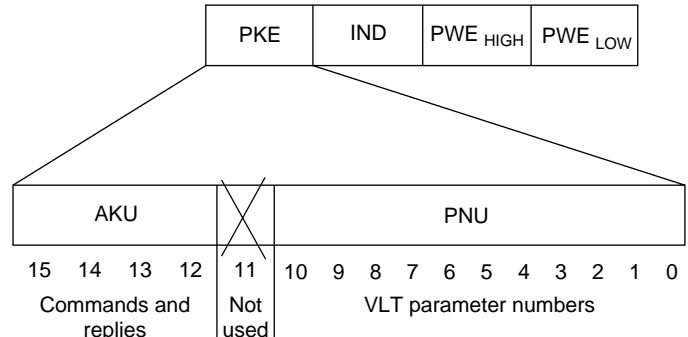

Commands and replies (AK)

Bits no. 12 - 15 are used for transmitting commands from master to slave regarding reading/writing to VLT parameters and the slave's processed reply back to the master. Any changes made only in RAM will be lost when power is removed from the VLT. Changes are made permanent by writing to RAM and EEPROM. See the Factory Settings Table to determine parameter data type.

(AK) Commands master → slave:

Bit no.

15	14	13	12	Command
0	0	0	0	No command
0	0	0	1	Read parameter value
0	0	1	0	Write parameter value in RAM (word)
0	0	1	1	Write parameter value in RAM (double word)
1	1	0	1	Write parameter value in RAM and EEPROM (double word)
1	1	1	0	Write parameter value in RAM and EEPROM (word)
1	1	1	1	Read text

(AK) Reply slave → master:

Bit no.

15	14	13	12	Reply
0	0	0	0	No reply
0	0	0	1	Parameter value transferred (word)
0	0	1	0	Parameter value transferred (double word)
0	1	1	1	Command cannot be executed
1	1	1	1	Text transferred

If the command cannot be executed, the slave will send this reply (0111) and give the following error message in the parameter bits (PNU).

Hex Error code	Error message
0	The parameter number used does not exist
1	There is no write access to the Parameter called
2	The data value exceeds the parameter limits
3	The used sub-index does not exist
4	The parameter is not of the array type
5	The data type does not match parameter called
11	Data change in the parameter called is not possible in the present mode of the VLT frequency converter. E.g. some parameters can only be changed when the motor has stopped
82	There is no bus access to the parameter called
83	Data change is not possible because factory Setup has been selected

Parameter number (PNU)

Bits no. 0 - 10 are used for transmitting parameter numbers. The function of a given parameter can be found in the VLT 5000 Series Instruction Manual. The parameter number will be in hexadecimal form, (VLT Parameter ...200 → 0C8Hex).

Index (IND)

PKE	IND	PWE
-----	------------	-----

The Index block is used with the parameter number for access to parameters of the array type. Several diagnostic parameters use arrays to log past fault types and drive status when fault occurred. Parameter 606 - 617 (data log) use arrays.

Parameter value (PWE)

PKE	IND	PWE
-----	-----	------------

The contents of the PWE block depends on the command given.

- If the master reads a parameter, the command telegram PWE block contains no value.
- If a parameter is changed by the master, the new parameter value is transferred in the PWE block.
- If the slave replies to a parameter read command, the PWE block will contain the parameter value.

When reading/writing to a parameter where all choices are in text format, the PWE value will correspond to a numerical value shown by each parameter description in the VLT 5000 Series Instruction Manual. For example, Parameter 001: Language has six choices, [0] corresponds to English, [1] corresponds to German, etc.

There are some parameters where the parameters values are transferred as an ASCII text string. When a text string is read by the master, the telegram length is variable, since the text strings will vary in length. The LGE byte of the reply telegram will reflect the proper telegram length. Parameters 621 - 631 (nameplate data) are of the text string type.

Data types supported by the VLT 5000 Series

Index	Description
3	Integer 16
4	Integer 32
5	Unsigned 8
6	Unsigned 16
7	Unsigned 32
9	Text string

Unsigned means there is no sign included in the telegram.

Since a parameter value can only be transferred as a whole number, conversion factors are assigned to each parameter to allow correct placement of the decimal point. (See Factory Settings Table for the data type of each VLT parameter.)

Conversion table:

Conversion index	Conversion factor
74	3.6
2	100
1	10
0	1
-1	0.1
-2	0.01
-3	0.001
-4	0.0001

Example:

Parameter 201 : minimum frequency, conversion factor 0.1. If parameter 201 is to be set to 10 Hz, a value of 100 must be transferred, since a conversion factor of 0.1 means that the transferred value will be multiplied by 0.1. A value of 100 will thus be understood as 10.

2. Process-bytes

The process byte block is divided into two parts, each part is 16 bits, which always come in the sequence stated. The format selected in Parameter 512 will determine the structure of the Control Word and the Status Word.

PCD1	PCD2
Control telegram (master→slave)	Control word
Reply telegram (slave→master)	Status word
	Bus Reference value (%)
	Output frequency (%)

The reply telegram will always contain an updated Status Word and percent output frequency.

■ VLT Standard Control Word

Control word as per VLT standard (parameter 512 = DANFOSS)

The control word is used for sending commands from a master (PC or PLC) to a slave (VLT 5000 Series).

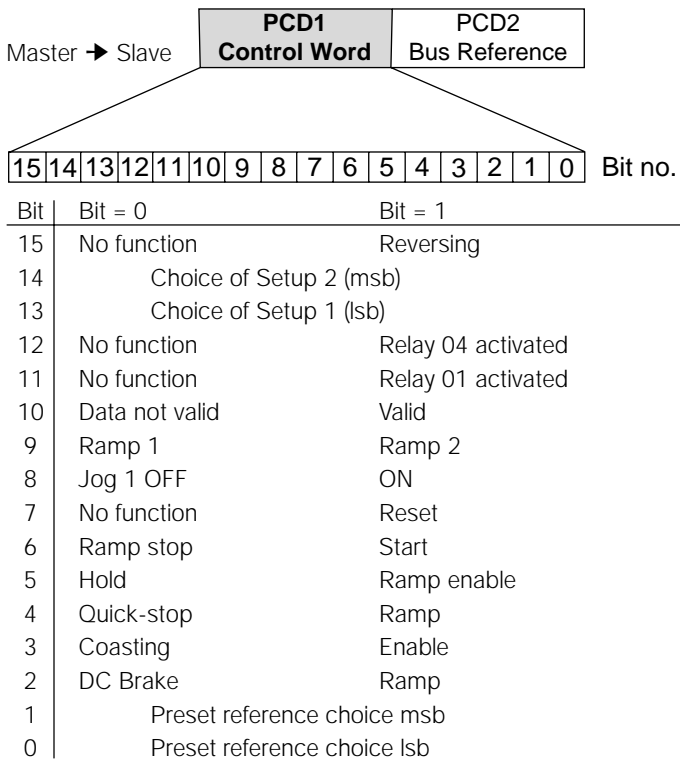

Bit 15: No function/reversing

Reversing the direction of motor rotation. Bit 15 = "0" will cause no reversing. Bit 15 = "1" will cause reversing only if parameter 506 is programmed for *bus, logic or or logic and*. For safety reasons, parameter 506 is factory set for *digital*.

Bits 13/14, Choice of Setup:

Bits 13 and 14 are used for choosing among the four menu sets in accordance with the following table. This function is only possible if parameter 004 is set to *Multi-Setup*. Parameter 507 is used to determine the gating between bus and digital setup control.

Setup	Bit 14	Bit 13
1	0	0
2	0	1
3	1	0
4	1	1

Bit 12: Relay 04

Bit 12 = "0" Relay 04 is not activated. Bit 12 = "1" Relay 04 is activated, if parameter 326 is set to *Control Word bit 11/12*.

Bit 11: Relay 01

Bit 11 = "0" Relay 01 is not activated. Bit 11 = "1" Relay 01 is activated, if parameter 323 is set to *Control Word bit 11/12*.

Bit 10, Data not valid/Valid:

This bit is used to determine if the VLT 5000 will respond to the control word. Bit 10 = "0" will cause the control word to be ignored. Bit 10 = "1" will allow the control word to be used. This function is important because the control word is always contained in the telegram. With this bit it is possible to disable the control word if it is not to be used, for example if the telegram is used just for read/writing a parameter.

Bit 09: Ramp1/Ramp2

Bit 09 = "0" will activate the Ramp 1 times programmed in parameters 207/208. Bit 09 = "1" will activate Ramp 2 times programmed in parameters 209/210.

Bit 08: Jog

When Bit 08 = "0", a jog will not be activated. When Bit 08 = "1", the motor will run at the Jog frequency programmed in parameter 213, using the Jog ramp programmed in parameter 211.

Bit 07: No function/reset

Bit 07 = "0" will cause no reset. Setting Bit 07 = "1" will cause a trip to be reset.

Bit 06: Ramp Stop/Start

Bit 06 = "0" causes a ramped stop using either ramp-down 1 (parameter 208) or ramp-down 2 (parameter 210). When Bit 06 = "1" the motor will begin accelerating using either ramp-up 1 (parameter 207) or ramp-up 2 (parameter 209) provided the other conditions for starting have been fulfilled. Parameter 505 is used to determine the gating between bus and digital control of ramp start/stop. In addition, Relay 01 and 04 will be activated when the output frequency is 0 Hz, provided Relay 123 has been selected in parameter 323 or 326.

Bit 05, Freeze output frequency/ramp enable:

Bit 05 = "0" will cause the output frequency to be maintained even if the reference signal is changed. Bit 05 = "1" will allow the adjustable frequency drive to again regulate the output frequency to the given reference.

Bit 04: Quick-stop

Bit 04 = "0" causes the motor to quick-stop using the ramp programmed in parameter 503. Bit 04 = "1" means that the adjustable frequency drive is able to start, provided the other conditions for starting are fulfilled. Parameter 503 is used to determine the gating between bus and digital control of quick-stop.

Bit 03: Coasting/Enable

Bit 03 = "0" causes the drive to release control of the motor and coast to a stop. Bit 03 = "1" means that the adjustable frequency drive is able to start provided the other conditions for starting are fulfilled. Parameter 502 is used to determine the gating between bus and digital control of coasting.

Bit 02: DC Brake

Bit 02 = "0" leads to DC injection braking to a stop. Brake current and Braking time are programmed separately in parameters 125 and 126. Bit 02 = "1" leads to normal ramp control.

Bit 00/01:

Bits 00 and 01 are used for choosing among the four pre-programmed digital references (parameters 215 - 218) in accordance with the following table. Parameter 508 is used to determine the gating between bus and digital control of the preset digital references.

Preset Ref.	Parameter	Bit 00	Bit 01
1	215	0	0
2	216	0	1
3	217	1	0
4	218	1	1

■ VLT Standard Status Word

Status word under the VLT standard
(Parameter 512 = DANFOSS)

The Status Word is used for informing the master (PC, PLC) about the condition of the slave (VLT 5000 Series).

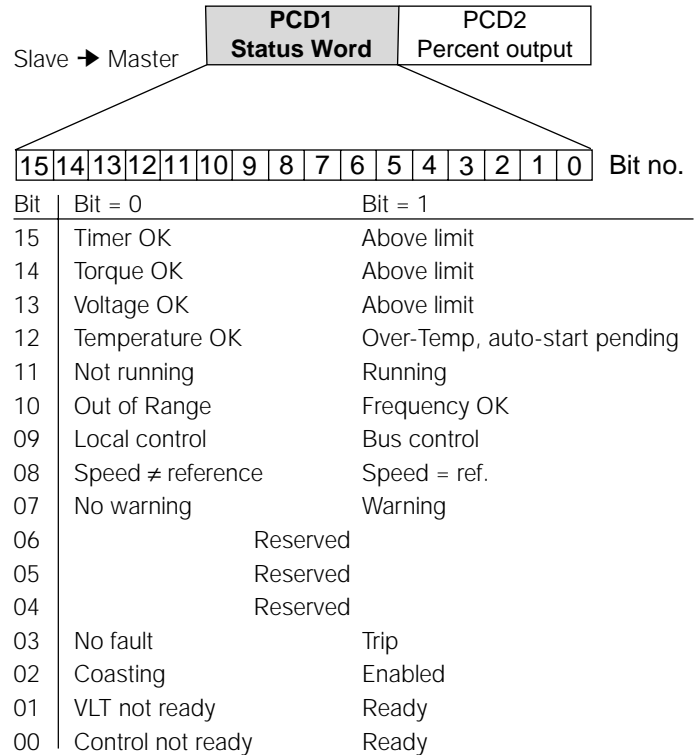

Bit 15, Timers OK/above limit:

Bit 15 = "0" means that the timers for the motor thermal protection and VLT thermal protection, respectively, have not exceeded 100%. Bit 15 = "1" means that one of the timers has exceeded 100%.

Bit 14, Torque OK/above limit:

Bit 14 = "0" means that the motor current is lower than the torque limit selected in parameter 221. Bit 14 = "1" means that the torque limit in parameter 221 has been exceeded.

Bit 13, Voltage OK/above limit:

Bit 13 = "0" means that the voltage limits of VLT 5000 Series have not been exceeded. Bit 13 = "1" means that the DC voltage of the VLT 5000 Series intermediate circuit is too low or too high.

Bit 12, VLT OK/stalling, autostart:

Bit 12 = "0" means that there is no temporary overtemperature on the inverter. Bit 12 = "1" means that the inverter has stopped because of overtemperature, but that the unit has not tripped and will continue, once the overtemperature stops.

Bit 11, Does not run/runs:

Bit 11 = "0" means that the motor is not running. Bit 11 = "1" means that VLT 5000 Series has a start signal of that the output frequency is greater than 0 Hz.

Bit 10, Out of operating range/Freq. limit OK:

Bit 10 = "0" means that the output frequency is out of the range set in parameter 225 (Warning: Low frequency) and parameter 226 (Warning: High frequency). Bit 10 = "1" means that the output frequency lies within the mentioned range.

Bit 09, Local control/Bus control:

Bit 09 = "0" means that VLT 5000 Series has been stopped by means of the stop key on the control panel, or that Local operation has been selected in parameter 002. Bit 09 = "1" means that it is possible to control the adjustable frequency drive via the serial port.

Bit 08, Speed ≠ ref/speed. = ref.:

Bit 08 = "0" means that the actual motor speed is different from the speed reference set. This can be the case while the speed is ramped up/down during start/stop. Bit 08 = "1" means that the present motor speed equals the speed reference set.

Bit 07, No warning/warning:

Bit 07 = "0" means that there is no unusual situation. Bit 07 = "1" means that an abnormal condition has arisen for the VLT 5000 Series. All warnings described in the VLT 5000 instruction manual will set bit 07 to "1".

Bit 06, Start enable/start disable:

Bit 06 is always "0" if Danfoss has been selected in parameter 512. If Profidrive has been selected in parameter 512, bit 06 will be "1" after reset of a trip, after activation of OFF2 or OFF3 and after connection of mains voltage. Start disable is reset, setting control word bit 00 to "0" and bits 01, 02 and 10 to "1".

Bit 05, ON3/OFF3:

Bit 05 = "0" means that control word bit 02 = "1".
Bit 05 = "1" means that control word bit 02 = "0".

Bit 04, ON2/OFF2:

Bit 04 = "0" means that control word bit 01 = "1".
Bit 04 = "1" means that control word bit 01 = "0".

Bit 03, No fault/trip:

Bit 03 = "0" means that VLT 5000 Series is not in a fault condition. Bit 03 = "1" means that VLT 5000 Series has tripped and needs a reset signal in order to run.

Bit 02, Coasting/enable:

Bit 02 = "0" means that the control word bit 00, 02 or 03 is "0" (OFF1, OFF2, OFF3 or Coasting), or the VLT 5000 Series unit has tripped. Bit 02 = "1" means that the control word bits 00, 01, 02 or 03 are "1" and that VLT 5000 Series has not tripped.

Bit 01, VLT not ready/ready:

Same meaning as bit 00; however, there is also a supply to the mains component, and the adjustable frequency drive is ready to run when it receives the necessary start signals.

Bit 00, Control not ready/ready:

Bit 00 = "0" means that bit 00, 01 or 02 of the control word is "0" (OFF1, OFF2 or OFF3), or that the adjustable frequency drive has tripped. Bit 00 = "1" means that the adjustable frequency drive is ready, but that there is not necessarily any supply to the power component (in case of external 24 V supply to the controls).

■ Profidrive Control Word

Control word as per Profidrive standard (parameter 512 = PROFIDRIVE)

The control word is used for transmitting commands from a master (e.g. a PC) to a slave (VLT 5000 Series).

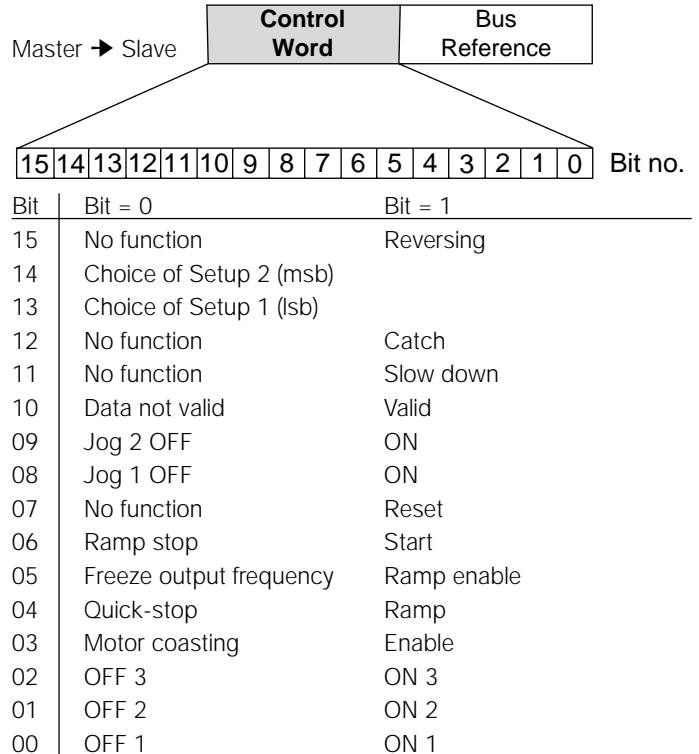

Bit 15, No function/reversing:

Reversing of the direction of rotation of the motor.
Bit 15 = "0" leads to no reversing, bit 15 = "1" leads to reversing.

Note that as a point of departure reversing has been selected as Digital in parameter 506. Bit 15 only leads to reversing if *bus*, *logical or* or *logical and* has been selected (*logical and*, however, only together with terminal 19).

NOTE: Unless otherwise mentioned, the control word bit is combined (gated) with the corresponding function on the digital inputs as a logical "or" function.

Bits 13/14, Choice of Setup:

Bits 13 and 14 are used for choosing among the four menu Setups in accordance with:

Setup	Bit 14	Bit 13
1	0	0
2	0	1
3	1	0
4	1	1

This function is only possible if Multi-Setups have been selected in parameter 004.

NOTE: Parameter 507 is used for choosing how bits 13/14 are to be combined (gated) with the corresponding function on the digital inputs.

Bit 12, No function/catch-up:

Used for increasing the speed reference by the value of parameter 219. Bit 12 = "0" means that the reference is increased. If both slow down and catch-up are activated (bits 11 and 12 = "1"), slow down has the higher priority, i.e. the speed reference is reduced.

Bit 11, No function/slow down:

Used for reducing the speed reference by the value in parameter 219. Bit 11 = "0" means that there is no change of the reference. Bit 11 = "1" means that the reference is reduced.

Bit 10, Data not valid/valid:

Used for telling VLT 5000 whether the control word and bus reference are to be used or ignored. Bit 10 = "0" means that the control word and bus reference are ignored. Bit 10 = "1" means that the control word and bus reference are used. This function is relevant because the control word and bus reference are always contained in the telegram, regardless of the type of telegram used, i.e. it is possible to disable the control word and bus reference if they are not to be used in connection with updating or reading of parameters.

Bit 09, Jog 2 OFF/ON:

Activation of pre-programmed speed in parameter 510 (Bus Jog 2). JOG 2 is only possible when Bit 04 = "0" and bits 00-03 = "1". If both JOG 1 and JOG 2 are activated (bits 08 and 09 = "1"), JOG 1 has the higher priority, which means that the speed programmed in parameter 509 will be used.

Bit 08, Jog 1 OFF/ON:

Activation of pre-programmed speed in parameter 509 (Bus Jog 1). JOG 1 is only possible when Bit 04 = "0" and bit 00-03 = "1".

Bit 07, No function/reset

Reset of trip. Bit 07 = "0" means that there is no reset. Bit 07 = "1" means that a trip is reset.

Bit 06, Ramp stop/start:

An ordinary ramp stop that uses the ramp time in parameters 207/208 or 209/210; in addition, output relay 01 or 04 will be activated when the output frequency is) Hz, provided Relay 123 has been selected in parameter 323 or 326. Bit 06 = "0" leads to a stop. Bit 06 = '1" means the adjustable frequency drive is able to start, provided the other conditions for starting are fulfilled. In parameter 505 the choice is made as to how bit 06 is to be combined (gated) with the corresponding function on the digital inputs.

Bit 05, Freeze output frequency/ramp enable:

Bit 05 = "0" means that the given output frequency is maintained even if the reference is changed. Bit 05 = "1" means that the adjustable frequency drive is again able to regulate, and the given reference is followed.

Bit 04, Quick-stop/ramp:

Quick-stop which uses the ramp time in parameter 212. Bit 04 = "0" leads to a quick- stop. Bit 04 = "1" means that the adjustable frequency drive is able to start, provided the other conditions for starting are fulfilled. Note: In parameter 503 the choice is made as to how dit o4 is to be combined (gated) with the corresponding function on the digital inputs.

Bit 03, Coasting/enable:

Coasting stop. Bit 03 = "0" leads to a stop. Bit 03 = "1" means that the adjustable frequency drive is able to stop, provided the other conditions for starting are fulfilled. Note: in parameter 502 the choice is made as to how bit 03 is to be combined (gated) with the corresponding function in the digital inputs.

Bit 02, OFF3/ON3:

Quick-stop, which uses the ramp time set in parameter 212. Bit 02 = "0" leads to a quick stop and leads to output relay 01 or 04 being activated, when the output frequency is 0 Hz, provided Relay 123 has been selected in parameter 323 or 326. Bit 02 = "1" means that the adjustable frequency drive is able to start, provided the other conditions for starting are fulfilled.

Bit 01, OFF2/ON2:

Coasting stop. Bit 01 = "0" leads to a coasting stop and leads to output relay 01 or 04 being activated, when the output frequency is 0 Hz, provided Relay 123 has been selected in parameter 323 or 326. Bit 01 = "1" means that the adjustable frequency drive is able to start provided the other conditions for starting are fulfilled.

Bit 00, OFF1/ON1:

An ordinary ramp stop which uses the ramp time in parameters 207/208 or 209/210. Bit 00 = "0" leads to a stop and leads to output relay 01 or 04 being activated, the output frequency is 0 Hz, provided Relay 123 has been selected in parameter 323 or 326. Bit 00 = "1" means that the adjustable frequency drive will be able to start if the other conditions for starting have been fulfilled.

■ Profidrive Status Word

Status word (according to Profidrive standard)
(parameter 512 = PROFIDRIVE)

The status word is used for informing the master (e.g. a PC) of the condition of a slave (VLT 5000 Series).

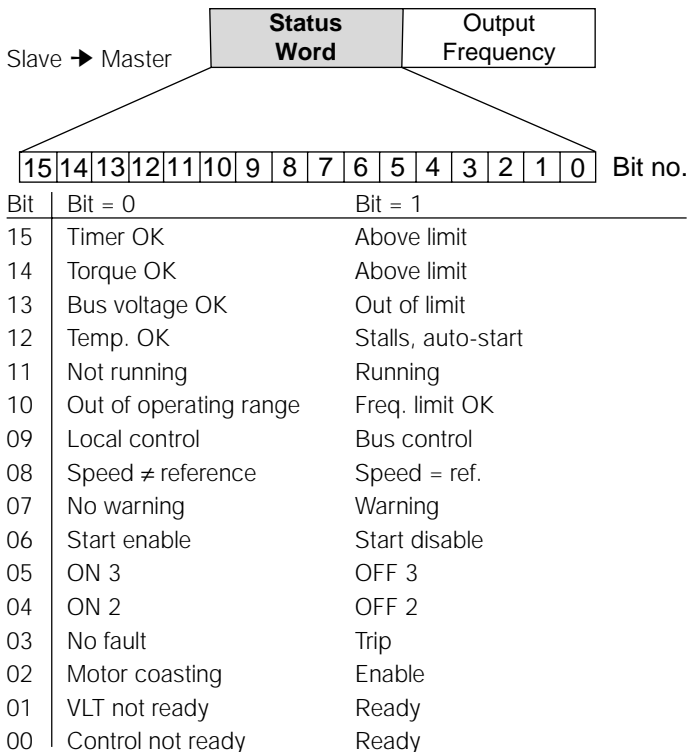

Bit 15, Timers OK/above limit:

Bit 15 = "0" means that the timers for the motor thermal protection and VLT thermal protection, respectively, have not exceeded 100%. Bit 15 = "1" means that one of the timers has exceeded 100%.

Bit 14, Torque OK/above limit:

Bit 14 = "0" means that the motor current is lower than the torque limit selected in parameter 221. Bit 14 = "1" means that the torque limit in parameter 221 has been exceeded.

Bit 13, Bus voltage OK/out of limit:

Bit 13 = "0" means that the voltage limits of VLT 5000 Series have not been exceeded. Bit 13 = "1" means that the DC voltage of the VLT 5000 Series intermediate circuit is too low or too high.

Bit 12, Temp. OK/stalling, autostart:

Bit 12 = "0" means that there is no temporary overtemperature on the inverter. Bit 12 = "1" means that the inverter has stopped because of overtemperature, but that the unit has not tripped and will continue, once the overtemperature stops.

Bit 11, Not running/running:

Bit 11 = "0" means that the motor is not running. Bit 11 = "1" means that VLT 5000 Series has a start signal and that the output frequency is greater than 0 Hz.

Bit 10, Out of operating range/Freq. limit OK:

Bit 10 = "0" means that the output frequency is out of the range set in parameter 225 (Warning: Low frequency) and parameter 226 (Warning: High frequency). Bit 10 = "1" means that the output frequency lies within the mentioned range.

Bit 09, Local control/Bus control:

Bit 09 = "0" means that VLT 5000 Series has been stopped by means of the stop key on the control panel, or that Local operation has been selected in parameter 002. Bit 09 = "1" means that it is possible to control the adjustable frequency drive via the serial port.

Bit 08, Speed ≠ ref/speed. = ref.:

Bit 08 = "0" means that the actual motor speed is different from the speed reference set. This can be the case while the speed is ramped up/down during start/stop. Bit 08 = "1" means that the present motor speed equals the speed reference set.

Bit 07, No warning/warning:

Bit 07 = "0" means that there is no unusual situation. Bit 07 = "1" means that an abnormal condition has arisen for the VLT 5000 Series. All warnings described in the VLT 5000 Series Instruction Manual #175R5271 will set bit 07 to "1".

Bit 06, Start enable/start disable:

Bit 06 is always "0" if Danfoss has been selected in parameter 512. If Profidrive has been selected in parameter 512, bit 06 will be "1" after reset of a trip, after activation of OFF2 or OFF3 and after connection of mains voltage. Start disable is reset, setting control word bit 00 to "0" and bits 01, 02 and 10 to "1".

Bit 05, ON3/OFF3:

Bit 05 = "0" means that control word bit 02 = "1".
 Bit 05 = "1" means that control word bit 02 = "0".

Bit 04, ON2/OFF2:

Bit 04 = "0" means that control word bit 01 = "1".
 Bit 04 = "1" means that control word bit 01 = "0".

Bit 03, No fault/trip:

Bit 03 = "0" means that VLT 5000 Series is not in a fault condition. Bit 03 = "1" means that VLT 5000 Series has tripped and needs a reset signal in order to run.

Bit 02, Coasting/enable:

Bit 02 = "0" means that the control word bit 00, 02 or 03 is "0" (OFF1, OFF2, OFF3 or Coasting), or the VLT 5000 Series unit has tripped. Bit 02 = "1" means that the control word bits 00, 01, 02 or 03 are "1" and that VLT 5000 Series has not tripped.

Bit 01, VLT not ready/ready:

Same meaning as bit 00; however, there is also a supply to the mains component, and the adjustable frequency drive is ready to run when it receives the necessary start signals.

Bit 00, Control not ready/ready:

Bit 00 = "0" means that bit 00, 01 or 02 of the control word is "0" (OFF1, OFF2 or OFF3), or that the adjustable frequency drive has tripped. Bit 00 = "1" means that the adjustable frequency drive is ready, but that there is not necessarily any supply to the power component (in case of external 24 V supply to the controls).

■ Bus reference value

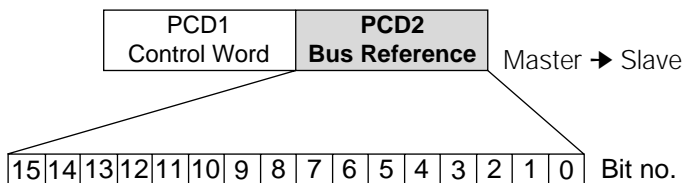

The frequency reference value is transmitted to the frequency converter in the form of a 16-bit word. The value is transmitted as a whole number. 16384_{10} (4000 Hex) corresponds to +100%. Negative numbers are formed by means of 2's complement.

The bus reference has the following format:

Parameter 203 = "0", $ref_{MIN} - ref_{MAX}$
 $0 - 16384$ (4000 Hex) $\approx 0 - 100\% \approx ref_{MIN} - ref_{MAX}$

Parameter 203 = "1", $-ref_{MIN} - +ref_{MAX}$
 -16384 (C000 Hex) - $+16384$ (4000 Hex) \approx
 $-100\% - +100\% \approx -ref_{MIN} - +ref_{MAX}$

■ Telegram Examples

The following examples assume that the Parameter 512 = DANFOSS.

Example 1:

Start Bus Address 01, 50% reference

STX	LGE	ADR	PCD1		PCD2		BCC
02	06	81	04	7C	20	00	DD

- STX: Always 02 Hex
- LGE: Short form telegram uses 06 Hex bytes
- ADR: Using Danfoss format, 81 Hex = bus address 01
- PCD1: 047C Hex - Control Word for start forward

Bit No.															
15	14	13	12	11	10	9	8	7	6	5	4	3	2	1	0
0				4				7				C			
0	0	0	0	0	1	0	0	0	1	1	1	1	1	0	0
No reverse	Setup msb	Setup lsb	Relay 04 disable	Relay 01 disable	Valid Control Word	Ramp 1	No Jog	No reset	Start	Ramp enable	Ramp	Enable	Ramp	Preset reference msb	Preset reference lsb

- PCD2: 2000 Hex - Bus Reference percentage of 50%

2000 Hex = 8192 decimal

$$\frac{8192}{16384} (100.0\%) = 50.0\%$$

[16384 is the 100% decimal value]

- BCC Calculation:

02	0000	0010
06	0000	0110
81	1000	0001
04	0000	0100
7C	0111	1100
20	0010	0000
00	0000	0000
XOR		
DD	1101	1101

Example 2:

Stop Bus Address 01, reference = 80%.

STX	LGE	ADR	PCD1		PCD2		BCC
02	06	81	04	3C	33	33	BD

- STX: Always 02 Hex
- LGE: Short form telegram uses 06 Hex bytes
- ADR: Using Danfoss format, 81 Hex = bus address 01.
- PCD1: 043C Hex - Control Word for ramp stop

Bit No.															
15	14	13	12	11	10	9	8	7	6	5	4	3	2	1	0
0				4				3				C			
0	0	0	0	0	1	0	0	0	1	1	1	1	1	0	0
No reverse	Setup msb	Setup lsb	Relay 04 disable	Relay 01 disable	Valid Control Word	Ramp 1	No Jog	No reset	Ramp stop	Ramp enable	Ramp	Enable	Ramp	Preset reference msb	Preset reference lsb

- PCD2: 3333 Hex - Bus Reference percentage of 80%

3333 Hex = 13107 decimal

$$\frac{13107}{16384} (100.0\%) = 80.0\%$$

[16384 is the 100% decimal value]

- BCC Calculation:

	02	0000	0010
	06	0000	0110
	81	1000	0001
	04	0000	0100
	3C	0011	1100
	33	0011	0011
	33	0011	0011
XOR			
	BD	1011	1101

Example 3:

Read output current (Parameter 520) of address 02. No change in Control Word or Bus Reference.

STX	LGE	ADR	PKE		IND		PWE _{HIGH}		PWE _{LOW}		PCD1		PCD2		BCC
02	0E	82	12	08	00	00	00	00	00	00	00	00	00	00	94

- STX: Always 02 Hex
- LGE: Long form telegram uses 14 (0E Hex) bytes
- ADR: Using Danfoss format, 82 Hex = bus address 02.
- PKE: AK = 1 (Read Parameter); PNU = 520 (208 Hex).

1				2				0				8							
AK				X	PNU														
0	0	0	1	0	0	1	0	0	0	0	0	0	0	0	1	0	0	0	0

- IND: Parameter 520 is not an Indexed parameter. (00)
- PWE: When reading a parameter, the PWE bytes are not used. (00)
- BCC: Calculation: (ignoring all 00 bytes)

	02	0000	0010
	0E	0000	1110
	82	1000	0001
	12	0001	0010
	08	0000	1000
XOR			
	94	1001	0100

- PCD: No Change to the Control Word or Bus Reference is required (00000000). The PCD can either be set to zero or left at last commanded values. If the Data valid Bit = 0, the FDC will be ignored.

The VLT response will look like the telegram sent except the PWE bytes will contain the value of parameter 520 multiplied by 100 (parameter 520 has a Conversion Index of -2, see Factory Settings Table). The reply telegram will also contain the current Status Word and Frequency Output Percentage in the PCD bytes.

Example 4:

At address 01, change and save parameter 205 (Maximum Reference) = 65.50 Hz. Give unit a run reverse command with a bus reference of 100%.

Note:

Parameter 506 must be set to allow bus reversing.

STE	LGE	ADR	PKE		IND		PWE _{HIGH}		PWE _{LOW}		PCD1		PCD2		BCC
02	0E	81	D0	CD	00	00	00	00	FF	DC	84	7C	40	00	0B

- STX: Always 02 Hex
- LGE: Long form telegram uses 14 (0E Hex) bytes
- ADR: Using Danfoss format, 81 Hex = bus address 01.
- PKE: D0CD Hex

AK = 1101 (D Hex) corresponding to a write parameter in RAM and EEPROM, double word). The Factory Settings Table indicates that Par 205 is a data type 4 = Integer 32 (double word)
 PNU = Parameter 205 (0CD Hex).

D				0				C				D				
AK				X	PNU											
1	1	0	1	0	0	0	0	0	1	1	0	0	1	1	0	1

- IND: Parameter 520 is not an Indexed parameter (0000)
- PWE: Par 205 has a conversion factor of -3 (see Factory Setting Table). A value of 65.500 would be entered, 65500 = 0000FFDC Hex.
- PCD1: 847C Hex - Control Word for start reverse

Bit No.															
15	14	13	12	11	10	9	8	7	6	5	4	3	2	1	0
8				4				7				C			
1	0	0	0	0	1	0	0	0	1	1	1	1	1	0	0
Reversing	Setup msb	Setup lsb	Relay 04 disable	Relay 01 disable	Valid Control Word	Ramp 1	No Jog	No reset	Start	Ramp enable	Ramp	Enable	Ramp	Preset reference msb	Preset reference lsb

- PCD2: 4000 Hex - Bus Reference percentage of 100%

$$4000 \text{ Hex} = 16384 \text{ decimal}$$

$$\frac{16384}{16384} (100.0\%) = 100.0\%$$

[16384 is the 100% decimal value]

- BCC Calculation: (ignoring all 00 Hex bytes)

02	0000	0010
0E	0000	1110
81	1000	0001
D0	1101	0000
CD	1100	1101
FF	1111	1111
DC	1101	1100
84	1000	0100
7C	0111	1100
40	0100	0000
XOR	<hr/>	
0B	0000	1011

■ **Serial Communication**
Parameter Group 5

500 Address	
(BUS ADDRESS)	
Value:	
0 - 126	★ 1

Function:
This parameter allows specification of the address of each VLT adjustable frequency drive. This feature is used in connection with PLC/PC connection.

Description of Data Value:
The individual VLT adjustable frequency drive can be given an address between 1 and 126. The address 0 is used if a master (PLC or PC) wishes to send a telegram that is to be received by all VLT adjustable frequency drives connected to the serial communication port at the same time. In this case, the VLT adjustable frequency drive will not acknowledge receipt. If the number of units connected (VLTs + master) exceeds 31, a repeater is required. Parameter 500 cannot be selected via the serial communication port.

501 Baudrate	
(BAUDRATE)	
Value:	
300 Baud (300) BAUD	[0]
600 Baud (600) BAUD	[1]
1200 Baud (1200) BAUD	[2]
2400 Baud (2400) BAUD	[3]
4800 Baud (4800) BAUD	[4]
★ 9600 Baud (9600) BAUD	[5]

Function:
This parameter is for programming the speed at which data is to be transmitted via the serial connection. Baud rate is defined as the number of bits transferred per second.

Description of Data Value:
The transmission speed of the VLT adjustable frequency drive is to be set at a value that corresponds to a transmission speed of the PLC/PC. Parameter 501 cannot be selected via the serial port, RS 485. The data transmission time proper, which is determined by the set baud rate, is only part of the total communication time.

★ = factory setting, () = display text, [] = data value for use in communication via serial communication port

502 Coasting (COASTING SELECT)
503 Quick-stop (Q STOP SELECT)
504 DC-Brake (DC BRAKE SELECT)
505 Start (START SELECT)
506 Reversing (REVERSING SELECT)
507 Selection of Setup (SETUP SELECT)
508 Selection of Speed (PRES.REF. SELECT)

Value:

Digital input (DIGITAL INPUT)	[0]
Bus (SERIAL PORT)	[1]
Logic and (LOGIC AND)	[2]
★ Logic or (LOGIC OR)	[3]

Function:

Parameters 502-508 allow a choice between controlling the VLT adjustable frequency drive via the terminals (digital input) and/or via the bus.

If Logic and or Bus is selected, the command in question can only be activated if transmitted via the serial communication port. In the case of Logic and, the command must additionally be activated via one of the digital inputs.

Description of Data Value:

Digital input [0] is selected if the control command in question is only to be activated via a digital input.

Bus [1] is selected if the control command in question is only to be activated via a bit in the control word (serial communication).

Logic and [2] is selected if the control command in question is only to be activated when a signal is transmitted (active signal = 1) via both a control word and a digital input.

Digital input 505-508	Bus	Control command
0	0	0
0	1	0
1	0	0
1	1	1

Logic or [3] is selected if the control command in question is to be activated when a signal is given (active signal = 1) either via a control word or via a digital input.

Digital input 505-508	Bus	Control command
0	0	0
0	1	1
1	0	1
1	1	1

NOTE:
Parameter 502-504 deal with stop functions - see examples regarding 502 (coasting) below. Active stop command "0"

Parameter 502 = Logic and

Digital Input	Bus	Control command
0	0	1 Coasting
0	1	0 Motor running
1	0	0 Motor running
1	1	0 Motor running

Parameter 502 = Logic or

Digital Input	Bus	Control command
0	0	1 Coasting
0	1	1 Coasting
1	0	1 Coasting
1	1	0 Motor running

503 Quick-stop (Q STOP SELECT)

Value:

Digital input (DIGITAL INPUT)	[0]
Bus (SERIAL PORT)	[1]
Logic and (LOGIC AND)	[2]
★ Logic or (LOGIC OR)	[3]

Function:
See description under parameter 502.

Description of Data Value:
See description under parameter 502.

504 DC-brake (DC BRAKE SELECT)

Value:

Digital input (DIGITAL INPUT)	[0]
Bus (SERIAL PORT)	[1]
Logic and (LOGIC AND)	[2]
★ Logic or (LOGIC OR)	[3]

Function:
See description under parameter 502.

Description of Data Value:
See description under parameter 502.

505 Start (START SELECT)

Value:

Digital input (DIGITAL INPUT)	[0]
Bus (SERIAL PORT)	[1]
Logic and (LOGIC AND)	[2]
★ Logic or (LOGIC OR)	[3]

Function:
See description under parameter 502.

Description of Data Value:
See description under parameter 502.

506 Reversing (REVERSING SELECT)

Value:

★ Digital input (DIGITAL INPUT)	[0]
Bus (SERIAL PORT)	[1]
Logic and (LOGIC AND)	[2]
Logic or (LOGIC OR)	[3]

Function:
See description under parameter 502.

Description of Data Value:
See description under parameter 502.

507 Selection of Setup (SETUP SELECT)

Value:

Digital input (DIGITAL INPUT)	[0]
Bus (SERIAL PORT)	[1]
Logic and (LOGIC AND)	[2]
★ Logic or (LOGIC OR)	[3]

Function:
See description under parameter 502.

Description of Data Value:
See description under parameter 502.

508 Selection of Speed (PRES.REF. SELECT)

Value:

Digital input (DIGITAL INPUT)	[0]
Bus (SERIAL PORT)	[1]
Logic and (LOGIC AND)	[2]
★ Logic or (LOGIC OR)	[3]

Function:
See description under parameter 502.

Description of Data Value:
See description under parameter 502.

★ = factory setting, () = display text, [] = data value for use in communication via serial communication port

509 Bus Jog 1 (BUS JOG 1 FREQ.)

Value:
0.0 - parameter 202 ★ 10.0 Hz

Function:
This is where to set a fixed speed (jog) that is activated via the serial communication port.
This function is the same as in parameter 213.

Description of Data Value:
The jog frequency f_{JOG} can be selected in the range between f_{MIN} (parameter 201) and f_{MAX} (parameter 202).

510 Bus Jog 2 (BUS JOG 2 FREQ.)

Value:
0.0 - parameter 202 ★ 10.0 Hz

Function:
This is where to set a fixed speed (jog) that is activated via the serial communication port.
This function is the same as in parameter 213.

Description of Data Value:
The jog frequency f_{JOG} can be selected in the range between f_{MIN} (parameter 201) and f_{MAX} (parameter 202).

512 Telegram Profile (TELEGRAM PROFILE)

Value:
Profidrive (PROFIDRIVE) [0]
★ Danfoss (DANFOSS) [1]

Function:
There is a choice of two different control word profiles.

Description of Data Value:
Select the desired control word profile.

513 Bus Time Interval (BUS TIMEOUT TIME)

Value:
1 - 99 sec. ★ 1 sec.

Function:
This parameter sets the maximum time expected to pass between the receipt of two consecutive telegrams. If this time is exceeded, the serial communication is assumed to have stopped and the desired reaction is set in parameter 514.

Description of Data Value:
Set the desired time.

514 Bus Time Interval Function (BUS TIMEOUT FUNC)

Value:

- ★ Off (OFF) [0]
- Freeze output (FREEZE OUTPUT) [1]
- Stop (STOP) [2]
- Jogging (JOGGING) [3]
- Max. speed (MAX SPEED) [4]
- Stop and trip (STOP AND TRIP) [5]

Function:
This parameter selects the desired reaction of the VLT adjustable frequency drive when the set time for bus time-out (parameter 513) has been exceeded.

Description of Data Value:
The output frequency of the VLT adjustable frequency drive can: be frozen at the present value, be frozen at the reference, go to stop, go to jogging frequency (parameter 202) or stop and activate a trip.

515 Data Read-out: Reference %
(REFERENCE)

Value:

Unit: %

Function:

This parameter can be read out via the serial communication port and via the display in Display mode. Also refer to parameters 009-012.

Description of Data Value:

The value shown corresponds to the total reference (sum of digital/analog/preset/bus/freeze reference/catch-up and slow-down).
 This value is updated every 80 ms.

516 Data Read-out: Reference unit
(REFERENCE [UNIT])

Value:

Unit: Hz, Hz or RPM

Function:

This parameter can be read out via serial communication port and via the display in Display mode. Also refer to parameters 009-012.

Description of Data Value:

Indicates the status value of terminals 17/29/53/54/60 at the unit given on the basis of the choice of configuration in parameter 100 (Hz, Hz and RPM).
 The value is updated every 80 ms.

517 Data Read-out: Feedback
(FFEDBACK [UNIT])

Value:

Unit: to be selected via parameter 416.

Function:

This parameter can be read out via the serial communication port and via the display in Display mode. Also refer to parameter 009-012.

Description of Data Value:

Indicates the status value of terminals 35/53/60 at the unit/scale selected in parameters 414, 415 and 416.
 This value is updated every 80 ms.

518 Data Read-out: Frequency
(FREQUENCY)

Value:

Unit: Hz

Function:

This parameter can be read out via the serial communication port and via the display in Display mode. Also refer to parameters 009-012.

Description of Data Value:

The value shown corresponds to the actual motor frequency f_M (without resonance dampening).
 This value is updated every 80 ms.

★ = factory setting, () = display text, [] = data value for use in communication via serial communication port

519 Data Read-out: Frequency x Scaling
(FREQUENCY x SCALE)

Value:
 Unit: (Hz x Scale)

Function:
 This parameter can be read out via the serial communication port and via the display in Display mode. Also refer to parameters 009-012.

Description of Data Value:
 The value shown corresponds to the actual motor frequency f_M (without resonance dampening) multiplied by a factor (scaling) set in parameter 008. This value is updated every 80 ms.

520 Data Read-out: Current
(MOTOR CURRENT)

Value:
 Unit: (Amp x 100)

Function:
 This parameter can be read out via the serial communication port and via the display in Display mode. Also refer to parameters 009-012.

Description of Data Value:
 The value shown corresponds to the given motor current measured as a mean value I_{RMS} . The value is filtered, which means that approximately 1.3 seconds may pass from an input value changes until the data read-out changes values. This value is updated every 80 ms.

521 Data Read-out: Torque
(TORQUE)

Value:
 Unit: %

Function:
 This parameter can be read out via the serial communication port and via the display in Display mode. Also refer to parameters 009-012.

Description of Data Value:
 The value shown is the torque, with sign, supplied to the motor shaft. The value is given as a percentage of the rated torque. There is not exact linearity between 160% motor current and torque in relation to the rated torque. Some motors supply more torque than that. Consequently, the min. value and max. value will depend on the max. motor current as well as the motor used. The value is filtered, which means that approximately 1.3 seconds may pass from an input changes value until the data read-out changes values. This value is updated every 80 ms.

NOTE:
 If the setting of the motor parameters does not match the motor applied, the read-out values will be inaccurate and may become negative, even if the motor is not running or is producing a positive torque.

522 Data Read-out: Power, kW
(POWER [kW])

Value:
 Unit: kW

Function:

This parameter can be read out via the serial communication port and via the display in Display mode. Also refer to parameters 009-012.

Description of Data Value:

The value shown is calculated on the basis of the actual motor voltage and motor current.
 The value is filtered, which means that it may take approximately 1.3 seconds from an input value changes until the data read-out changes values.
 This value is updated every 80 ms.

523 Data Read-out: Power, HP
(POWER [HP])

Value:
 Unit: HP

Function:

This parameter can be read out via the serial communication port and display in Display mode. Also refer to parameters 009-012.

Description of Data Value:

The value shown is calculated on the basis of the actual motor voltage and motor current.
 The value is indicated in the form of HP.
 The value is filtered, which means that approximately 1.3 seconds may pass from an input value changes until the data read-out changes values.
 The value is updated every 80 ms.

524 Data Read-out: Motor Voltage
(MOTOR VOLTAGE)

Value:
 Unit: V

Function:

This parameter can be read out via the serial communication port and via the display in Display mode. Also refer to parameters 009-012.

Description of Data Value:

The value shown is a calculated value used for controlling the motor.
 This value is updated every 80 ms.

525 Data Read-out: DC Link Voltage
(DC LINK VOLTAGE)

Value:
 Unit: V

Function:

This parameter can be read out via the serial communication port and via the display in Display mode. Also refer to parameters 009-012.

Description of Data Value:

The value shown is a measured value.
 The value is filtered, which means that it may take approximately 1.3 seconds from an input value changes until the data read-out changes values.
 This value is updated every 80 ms.

★ = factory setting, () = display text, [] = data value for use in communication via serial communication port

**526 Data Read-out: Motor Temperature
(MOTOR THERMAL)**

Value:

0 - 100%

Function:

This parameter can be read out via the serial communications port and via the display in Display mode.

Description of Data Value:

This value is updated every 80 ms.

**527 Data Read-out: VLT Temperature
(VLT THERMAL)**

Value:

0 - 100%

Function:

This parameter can be read out via the serial communication port and via the display in Display mode. Also refer to parameters 009-012.

Description of Data Value:

Only whole numbers are displayed.
This value is updated every 80 ms.

**528 Data Read-out: Digital Input
(DIGITAL INPUT)**

Value:

Unit: binary code

Function:

This parameter can be read out via the serial communication port and via the display in Display mode. Also refer to parameters 009-012.

Description of Data Value:

The value shown indicates the signal status from the 8 digital terminals (16, 17, 18, 19, 27, 29 32 and 33). The read-out is binary and the digit at the extreme left gives the status of terminal 33, while the digit at the extreme right gives the status of terminal 16. This value is updated every 80 ms.

**529 Data Read-out: Terminal 53, Analog input
(ANALOG INPUT 53)**

Value:

Unit: V

Function:

This parameter can be read out via the serial communication port and via the display in Display mode. Also refer to parameters 009-012.

Description of Data Value:

The value shown indicates the signal value on terminal 53.
The scaling (parameters 309 and 310) does not influence the read-out. Min. and Max. are determined by the offset and gain adjustment of the AD-converter.
This value is updated every 20 ms.

530 Data Read-out: Terminal 54, Analog Input
(ANALOG INPUT 54)

Value:

Unit: V

Function:

This parameter can be read out via the serial communication port and via the display in Display mode. Also refer to parameters 009-012.

Description of Data Value:

The value shown indicates the signal value on terminal 54. The scaling (parameters 312 and 313) does not influence the read-out. Min. and Max. are determined by the offset and gain adjustment of the AD-converter. This value is updated every 20 ms.

531 Data Read-out: Terminal 60, Analog input
(ANALOG INPUT 60)

Value:

Unit: mA

Function:

This parameter can be read out via the serial communication port and via the display in Display mode. Also refer to parameters 009-012.

Description of Data Value:

The value shown indicates the signal value on terminal 60. The scaling (parameters 315 and 316) does not influence the read-out. Min. and Max. are determined by the offset and gain adjustment of the AD-converter. This value is updated every 20 ms.

532 Data Read-out: Pulse Reference
(PULSE REFERENCE)

Value:

Unit: Hz

Function:

This parameter can be read out via the serial communication port and via the display in Display mode. Also refer to parameters 009-012.

Description of Data Value:

The value shown indicates any pulse reference in Hz connected to one of the digital inputs. This value is updated every 20 ms.

533 Data Read-out: External Reference %
(EXT. REFERENCE)

Value:

-200 - +200%

Function:

This parameter can be read out via the serial communication port and via the display in Display mode. Also refer to parameters 009-012.

Description of Data Value:

The value stated gives, as a percentage, the sum of external references (sum of analog/bus/pulse). This value is updated every 20 ms.

★ = factory setting, () = display text, [] = data value for use in communication via serial communication port

534 Data Read-out: Status Word, Binary
(STATUS WORD [HEX])

Value:

Unit: binary code

Function:

This parameter can be read out via the serial communication port and via the display in Display mode. Also refer to parameters 009-012.

Description of Data Value:

Indicates the status word transmitted via the serial communication port in Hex code from the VLT adjustable frequency drive.

535 Data Read-out: Brake Power/2 min.
(BR. ENERGY/2min)

Value:

Unit: kWh

Function:

This parameter can be read out via the serial communication port and via the display in Display mode. Also refer to parameters 009-012.

Description of Data Value:

Indicates the brake power transmitted to an external brake resistor. The mean power is calculated on an ongoing basis for the latest 120 seconds.

536 Data Read-out: Brake Power/Sec.
(BRAKE ENERGY/S)

Value:

Unit: kWh

Function:

This parameter can be read out via the serial communication port and via the display in Display mode. Also refer to parameters 009-012.

Description of Data Value:

Indicates the given brake power transmitted to an external brake resistor. Stated as an instantaneous value.

537 Data Read-out: Heat Sink Temperature
(HEATSINK TEMP.)

Value:

Unit: °C

Function:

This parameter can be read out via the serial communication port and via the display in Display mode. Also refer to parameters 009-012.

Description of Data Value:

States the given heat sink temperature of the VLT adjustable frequency drive. The cut-out limit is $90 \pm 5^\circ\text{C}$, while the unit cuts back in at $60 \pm 5^\circ\text{C}$.

538 Data Read-out: Alarm Word, Binary
(ALARM WORD [HEX])

Value:

Unit: binary code

Function:

This parameter can be read out via the serial communication port and via the display in Display mode. Also refer to parameters 009-012.

Description of Data Value:

States in Hex format whether there is an alarm on the VLT adjustable frequency drive.

539 Data Read-out: VLT Control Word, Binary
(CONTROL WORD [HEX])

Value:

Unit: binary code

Function:

This parameter can be read out via the serial communication port and via the display in Display mode. Also refer to parameters 009-012.

Description of Data Value:

Indicates the control word sent via serial communication port in Hex code from the VLT adjustable frequency drive.

540 Data Read-out: Warning Word, 1
(WARN. WORD 1)

Value:

Unit: binary code

Function:

This parameter can be read out via the serial communication port and via the display in Display mode. Also refer to parameters 009-012.

Description of Data Value:

States in a Hex format whether there is a warning on the VLT adjustable frequency drive.

541 Data Read-out: Warning Word, 2
(WARN. WORD 2)

Value:

Unit: binary code

Function:

This parameter can be read out via the serial communication port and via the display in Display mode. Also refer to parameters 009-012.

Description of Data Value:

States in a Hex format whether there is a warning on the VLT adjustable frequency drive.

★ = factory setting, () = display text, [] = data value for use in communication via serial communication port

■ Factory Settings Table

Online:

"Yes" means that the parameter can be changed, while the VLT adjustable frequency drive is in operation. "No" means that the VLT adjustable frequency drive must be stopped before a change can be made.

4-Setup:

"Yes" means that the parameter can be programmed individually in each of the four setups, i.e. the same parameter can have different data values. "No" means that the data value will be the same in all four setups.

Conversion index:

This number refers to a conversion figure to be used when writing or reading by means of a VLT adjustable frequency drive.

Data type:

Data type shows the type and length of the telegram.

Conversion Table

Conversion Index	Conversion factor
74	3.4
2	100
1	10
0	1
-1	0.1
-2	0.01
-3	0.001
-4	0.0001

Data Type Table

Data Type	Description
3	Integer 16
4	Integer 32
5	Unsigned 8
6	Unsigned 16
7	Unsigned 32
9	Text string

Group 0, Operation & Display

No.	Parameter Description	Factory Setting	Range	Online	4-Setup	Conversion Index	Data Type
001	Language	English		yes	no	0	5
002	Local/remote control	Remote control		yes	yes	0	5
003	Local reference	000.000		yes	yes	-3	4
004	Active setup	Setup 1		yes	no	0	5
005	Programming setup	Active setup		yes	no	0	5
006	Copying of setups	No copying		no	no	0	5
007	LCP copy	No copying		no	no	0	5
008	Display scaling of motor frequency	1	0.01-100.00	yes	yes	-2	6
009	Display line 2	Frequency [Hz]		yes	yes	0	5
010	Display line 1.1	Reference [%]		yes	yes	0	5
011	Display line 1.2	Motor current [A]		yes	yes	0	5
012	Display line 1.3	Power [kW]		yes	yes	0	5
013	Local control/configuration	LCP control/as parameter 100		yes	yes	0	5
014	Local stop	Possible		yes	yes	0	5
015	Local jog	Not possible		yes	yes	0	5
016	Local reversing	Not possible		yes	yes	0	5
017	Local reset of trip	Possible		yes	yes	0	5
019	Operating state at power-up, local control	Forced stop, use saved ref.		yes	yes	0	5

Group 1, Load & Motor

No.	Parameter Description	Factory Setting	Range	Online	4-Setup	Conversion Index	Data Type
100	Configuration	Speed, open loop mode		no	yes	0	5
101	Torque characteristics	High - constant torque		yes	yes	0	5
102	Motor power	Depends on unit	0.18-45 kW	no	yes	1	6
103	Motor voltage	Depends on unit	200-500 V	no	yes	0	6
104	Motor frequency	50 Hz		no	yes	0	6
105	Motor current	Depends on motor	0.01- $I_{VLT,MAX}$	no	yes	-2	7
106	Rated motor speed	Depends on motor	100-60000 rpm	no	yes	0	6
107	Automatic motor adaptation	Adaptation off		no	no	0	5
108	Stator resistor	Depends on motor		no	yes	-4	7
109	Stator reactance	Depends on motor		no	yes	-2	7
110	Motor magnetizing, 0 rpm	100%	0-300%	yes	yes	0	6
111	Min. frequency normal magnetizing	1.0 Hz	0.1-10.0 Hz	yes	yes	-1	6
113	Load compensation at low speed	100 %	0-300 %	yes	yes	0	6
114	Load compensation at high speed	100 %	0-300 %	yes	yes	0	6
115	Slip compensation	100 %	-500-500 %	yes	yes	0	3
116	Slip compensation time constant	0.50 sec	0.05-1.00 sec	yes	yes	-2	6
117	Resonance dampening	100 %	0-500 %	yes	yes	0	6
118	Resonance dampening time constant	5 ms	5-50 ms	yes	yes	-3	6
119	High starting torque	0.0 sec	0.0-0.5 sec	yes	yes	-1	5
120	Start delay	0.0 sec	0.0-10.0 sec	yes	yes	-1	5
121	Start function	Coasting in start delay time		yes	yes	0	5
122	Function at stop	Coasting		yes	yes	0	5
123	Min. frequency for activating function at stop	0.0 Hz	0.0-10.0 Hz	yes	yes	-1	5
124	DC holding current	50 %	0-100 %	yes	yes	0	6
125	DC braking current	50 %	0-100 %	yes	yes	0	6
126	DC braking time	10.0 sec	0.0-60.0 sec	yes	yes	-1	6
127	DC brake cut-in frequency	0.0 Hz	0.0-parameter 202	yes	yes	-1	6
128	Motor thermal protection	No protection		yes	yes	0	5
129	External motor fan	No		yes	yes	0	5
130	Start frequency	0.0 Hz	0.0-10.0 Hz	yes	yes	-1	5
131	Initial voltage	0.0 V	0.0-parameter 103	yes	yes	-1	6

Group 2, References & Limits

No.	Parameter Description	Factory Setting	Range	Online	4-Setup	Conversion Index	Data Type
200	Output frequency range/direction	Only clockwise, 0-132 Hz	Hz	no	yes	0	5
201	Output frequency low limit	0.0 Hz	0.0- f_{MAX}	yes	yes	-1	6
202	Output frequency high limit	132 Hz	f_{MIN} -parameter 200	yes	yes	-1	6
203	Reference/feedback area	Min-Max		yes	yes	0	5
204	Minimum reference	0.000	-100,000.000-RefMAX	yes	yes	-3	4
205	Maximum reference	50.000	Ref $_{MIN}$ -1.000.000.000	yes	yes	-3	4
206	Ramp type	Linear		yes	yes	0	5
207	Ramp-up time 1	Depends on unit	0.05-3600	yes	yes	-2	7
208	Ramp-down time 1	Depends on unit	0.05-3600	yes	yes	-2	7
209	Ramp-up time 2	Depends on unit	0.05-3600	yes	yes	-2	7
210	Ramp-down time 2	Depends on unit	0.05-3600	yes	yes	-2	7
211	Jog ramp time	Depends on unit	0.05-3600	yes	yes	-2	7
212	Quick stop ramp-down time	Depends on unit	0.05-3600	yes	yes	-2	7

No.	Parameter Description	Factory Setting	Range	Online	4-Setup	Conversion Index	Data Type
213	Jog frequency	10.0 Hz	0.0-parameter 202	yes	yes	-1	6
214	Reference function	Sum		yes	yes	0	5
215	Preset reference 1	0.00 %	-100.00 - +100.00 %	yes	yes	-2	3
216	Preset reference 2	0.00 %	-100.00 - +100.00 %	yes	yes	-2	3
217	Preset reference 3	0.00 %	-100.00 - +100.00 %	yes	yes	-2	3
218	Preset reference 4	0.00 %	-100.00 - +100.00 %	yes	yes	-2	3
219	Catch up/slow down value	0.00 %	0.00 - +100 %	yes	yes	-2	6
221	Torque limit for motor mode	160 % of $T_{M,N}$	0.0 % - xxx %	yes	yes	-1	6
222	Torque limit for regenerative operation	10 %	0.0 % - xxx %	yes	yes	-1	6
223	Warning: Low current	0.0 A	0.0-parameter 224	yes	yes	-1	6
224	Warning: High current	$I_{VLT,MAX}$	parameter 223- $I_{VLT,MAX}$	yes	yes	-1	6
225	Warning: Low frequency	0.0 Hz	0.0-parameter 226	yes	yes	-1	6
226	Warning: High frequency	132.0 Hz	par. 225-par. 202	yes	yes	-1	6
227	Warning: Low feedback	-4000.000	-100,000.000-par. 228	yes	yes	-3	4
228	Warning: High feedback	4000.000	par. 227-100,000.000	yes	yes	-3	4
229	Frequency bypass, bandwidth	0 (OFF) %	0-100 %	yes	yes	0	6
230	Frequency bypass 1	0.0 Hz	0.0-parameter 200	yes	yes	-1	6
231	Frequency bypass 2	0.0 Hz	0.0-parameter 200	yes	yes	-1	6
232	Frequency bypass 3	0.0 Hz	0.0-parameter 200	yes	yes	-1	6
233	Frequency bypass 4	0.0 Hz	0.0-parameter 200	yes	yes	-1	6

Group 3, Inputs & Outputs

No.	Parameter Description	Factory Setting	Range	Online	4-Setup	Conversion Index	Data Type
300	Terminal 16, input	Reset		yes	yes	0	5
301	Terminal 17, input	Freeze reference		yes	yes	0	5
302	Terminal 18 Start, input	Start		yes	yes	0	5
303	Terminal 19, input	Reversing		yes	yes	0	5
304	Terminal 27, input	Coasting stop, inverse		yes	yes	0	5
305	Terminal 29, input	Jog		yes	yes	0	5
306	Terminal 32, input	Choice of setup, msb/speed up		yes	yes	0	5
307	Terminal 33, input	Choice of setup, lsb/speed down		yes	yes	0	5
308	Terminal 53, analog input voltage	Reference		yes	yes	0	5
309	Terminal 53, min. scaling	0.0 V	0.0-10.0 V	yes	yes	-1	5
310	Terminal 53, max. scaling	10.0 V	0.0-10.0 V	yes	yes	-1	5
311	Terminal 54, analog input voltage	No operation		yes	yes	0	5
312	Terminal 54, min. scaling	0.0 V	0.0-10.0 V	yes	yes	-1	5
313	Terminal 54, max. scaling	10.0 V	0.0-10.0 V	yes	yes	0	5
314	Terminal 60, analog input current	Reference		yes	yes	0	5
315	Terminal 60, min. scaling	0.0 mA	0.0-20.0 mA	yes	yes	-4	5
316	Terminal 60, max, scaling	20.0 mA	0.0-20.0 mA	yes	yes	-4	5
317	Time out	10 sec	1-99 sec	yes	yes	0	5
318	Function after time out	Off		yes	yes	0	5
319	Terminal 42, output	$0-I_{MAX} = 0-20$ mA		yes	yes	0	5
320	Terminal 42, output, pulse scaling	5000 Hz	1-32000 Hz	yes	yes	0	6
321	Terminal 45, output	$0-f_{MAX} = 0-20$ mA	1-32000 Hz	yes	yes	0	5
322	Terminal 45, output, pulse scaling	5000 Hz	1-32000 Hz	yes	yes	0	6
323	Relay 01, output	Ready - no thermal warning		yes	yes	0	5
324	Relay 01, ON delay	0.00 sec	0.00-10.00 min	yes	yes	-2	6
325	Relay 01, OFF delay	0.00 sec	0.00-10.00 min	yes	yes	-2	6

No.	Parameter Description	Factory Setting	Range	Online	4-Setup	Conversion Index	Data Type
326	Relay 04, output	Ready - remote control		yes	yes	0	5
327	Pulse reference, max. frequency	5000 Hz		yes	yes	0	6
328	Pulse feedback, max. frequency	25000 Hz		yes	yes	0	6
329	Encoder feedback pulse/rev.	1024 pulses/rev.	1-4096 pulses/rev.	yes	yes	0	6

Group 4, Special functions

No.	Parameter Description	Factory Setting	Range	Online	4-Setup	Conversion Index	Data Type
400	Brake function	Off		yes	no	0	5
401	Brake resistor, ohm	Depends on unit		yes	no	-1	6
402	Brake power limit, kW	Depends on unit		yes	no	2	6
403	Power monitoring	On		yes	no	0	5
404	Brake check	Off		yes	no	0	5
405	Reset function	Manual reset		yes	yes	0	5
406	Automatic restart time	5 sec	0-10 sec	yes	yes	0	5
407	AC line failure	No function		yes	yes	0	5
408	Quick discharge	Not possible		yes	yes	0	5
409	Trip delay torque	Off	0-60 sec	yes	yes	0	5
410	Trip-delay inverter	Depends on unit	0-35 sec	yes	yes	0	5
411	Switching frequency	Depends on unit output	3-5 kHz	yes	yes	2	6
412	Output frequency dependent switching frequency	Not possible		yes	yes	0	5
413	Overmodulation function	On		yes	yes	-1	5
414	Minimum feedback	0.000	-100,000.000-FB _{HIGH}	yes	yes	-3	4
415	Maximum feedback	1500.000	FB _{LOW} -100,000.000	yes	yes	-3	4
416	Process unit	%		yes	yes	0	5
417	Speed PID proportional gain	0.015	0.000-0.150	yes	yes	-3	6
418	Speed PID integral time	8 ms	2.00-999.99 ms	yes	yes	-4	7
419	Speed PID differential time	30 ms	0.00-200.00 ms	yes	yes	-4	6
420	Speed PID D-gain limit	5.0	5.0-50.0	yes	yes	-1	6
421	Speed PID lowpass filter time	10 ms	5-200 ms	yes	yes	-4	6
422	U 0 voltage at 0 Hz	20.0 V	0.0-parameter 103	yes	yes	-1	6
423	U 1 voltage	parameter 103	0.0 V _{VLT,MAX}	yes	yes	-1	6
424	F 1 frequency	parameter 104	0.0-parameter 426	yes	yes	-1	6
425	U 2 voltage	parameter 103	0.0 - V _{VLT,MAX}	yes	yes	-1	6
426	F 2 frequency	parameter 104	par. 424 - par. 428	yes	yes	-1	6
427	U 3 voltage	parameter 103	0.0 - V _{VLT,MAX}	yes	yes	-1	6
428	F 3 frequency	parameter 104	par. 426 - par. 430	yes	yes	-1	6
429	U 4 voltage	parameter 103	0.0 - V _{VLT,MAX}	yes	yes	-1	6
430	F 4 frequency	parameter 104	par. 428 - par. 432	yes	yes	-1	6
431	U 5 voltage	parameter 103	0.0 - V _{VLT,MAX}	yes	yes	-1	6
432	F 5 frequency	parameter 104	par. 430 - 1000 Hz	yes	yes	-1	6
433	Torque proportional gain	100 %	0 (Off) - 500 %	yes	yes	0	6
434	Torque integral time	0.02 sec	0.002-2.000 sec.	yes	yes	-3	7
437	Process PID Normal/inverse control	Normal		yes	yes	0	5
438	Process PID anti windup	On		yes	yes	0	5
439	Process PID start frequency	parameter 201	f _{MIN} - f _{MAX}	yes	yes	28	6
440	Process PID proportional gain	0.01	0.00-10.00	yes	yes	0	6
441	Process PID integral time	Off	0.01-9999.99 sec	yes	yes	4	7
442	Process PID differentiation time	0.00 sec (Off)	0.00_10.00 sec	yes	yes	4	6

No.	Parameter Description	Factory Setting	Range	Online	4-Setup	Conversion Index	Data Type
443	Process PID differentiation gain limit	5.0	5.0-50.0	yes	yes	0	6
444	Process PID lowpass filter time	0.01	0.01-10.00	yes	yes	4	6
445	Flying start	Off		yes	yes	0	5
446	Switching pattern	Automatic		yes	yes	0	5

Group 5, Serial Communication

No.	Parameter Description	Factory Setting	Range	Online	4-Setup	Conversion Index	Data Type
500	Address	1	0-126	yes	no	0	6
501	Baudrate	9600 Baud		yes	no	0	5
502	Coasting	Logic or		yes	yes	0	5
503	Quick-stop	Logic or		yes	yes	0	5
504	DC-brake	Logic or		yes	yes	0	5
505	Start	Logic or		yes	yes	0	5
506	Reversing	Logic or		yes	yes	0	5
507	Selection of setup	Logic or		yes	yes	0	5
508	Selection of speed	Logic or		yes	yes	0	5
509	Bus jog 1	10.0 Hz	0.0-parameter 202	yes	yes	-1	6
510	Bus jog 2	10.0 Hz	0.0-parameter 202	yes	yes	-1	6
512	Telegram profile	Danfoss		no	yes	0	5
513	Bus time interval	1 sec	1-99 sec	yes	yes	0	5
514	Bus time interval function	Off		yes	yes	0	5
515	Data read-out: Reference %			no	yes	-1	3
516	Data read-out: Reference unit			no	yes	-3	4
517	Data read-out: Feedback			no	yes	-3	4
518	Data read-out: Frequency			no	yes	-1	6
519	Data read-out: Frequency x Scaling			no	yes	-2	7
520	Data read-out: Current			no	yes	-2	7
521	Data read-out: Torque			no	yes	-1	3
522	Data read-out: Power, kW			no	yes	-1	7
523	Data read-out: Power, HP			no	yes	-2	7
524	Data read-out: Motor voltage			no	yes	-1	6
525	Data read-out: DC link voltage			no	yes	0	6
526	Data read-out: Motor temperature			no	yes	0	5
527	Data read-out: VLT temp.			no	yes	0	5
528	Data read-out: Digital input			no	yes	0	5
529	Data read-out: Terminal 53, analog input			no	yes	-1	3
530	Data read-out: Terminal 54, analog input			no	yes	-1	3
531	Data read-out: Terminal 60, analog input			no	yes	-4	3
532	Data read-out: Pulse reference			no	yes	-1	7
533	Data read-out: External reference %			no	yes	-1	3
534	Data read-out: Status word, binary			no	yes	0	6
535	Data read-out: Brake power/2 min.			no	yes	2	6
536	Data read-out: Brake power/sec.			no	yes	2	6
537	Data read-out: Heat sink temperature			no	yes	0	5
538	Data read-out: Alarm word, binary			no	yes	0	6
539	Data read-out: VLT control word, binary			no	yes	0	6
540	Data read-out: Warning word, 1			no	yes	0	7
541	Data read-out: Warning word, 2			no	yes	0	7

Group 6, Technical Functions

No.	Parameter Description	Factory Setting	Range	Online	4-Setup	Conversion Index	Data Type
600	Operating data: Operating hours			no	no	73	7
601	Operating data: Hours run			no	no	73	7
602	Operating data: kWh counter			no	no	73	7
603	Operating data: Number of power-ups			no	no	0	6
604	Operating data: Number of overtemperatures			no	no	0	6
605	Operating data: Number of overvoltages			no	no	0	6
606	Data log: Digital input			no	no	0	5
607	Data log: Bus commands			no	no	0	6
608	Data log: Bus status word			no	no	0	6
609	Data log: Reference			no	no	-1	3
610	Data log: Feedback			no	no	-3	4
611	Data log: Motor frequency			no	no	-1	3
612	Data log: Motor voltage			no	no	-1	6
613	Data log: Motor current			no	no	-2	3
614	Data log: DC link voltage			no	no	0	6
615	Fault log: Error code			no	no	0	5
616	Fault log: Time			no	no	0	7
617	Fault log: Value			no	no	0	3
618	Reset of kWh counter			yes	no	0	5
619	Reset of hours-run counter			yes	no	0	5
620	Operating mode Normal function			yes	no	0	5
621	Nameplate: VLT type			no	no	0	9
622	Nameplate: Power section			no	no	0	9
623	Nameplate: VLT ordering no.			no	no	0	9
624	Nameplate: Software version no.			no	no	0	9
625	Nameplate: LCP identification no.			no	no	0	9
626	Nameplate: Database identification no.			no	no	-2	9
627	Nameplate: Power section identification no.			no	no	0	9
628	Nameplate: Application option type			no	no	0	9
629	Nameplate: Application option ordering no.			no	no	0	9
630	Nameplate: Communication option type			no	no	0	9
631	Nameplate: Communication option ordering no.			no	no	0	9