

DRAWING	REVISION	VERSION

UNLESS OTHERWISE SPECIFIED ALL DIMENSIONS ARE IN INCHES. TOLERANCE:

X ± 0.1
 XX ± 0.03
 XXX ± 0.005

ANGLES ± 2.0° HOLE DIA = +
 CONFORMS TO ASME Y14.5M-1994.

FINISH ✓

TRANE

THIS DRAWING IS PROPRIETARY AND SHALL NOT BE COPIED OR ITS CONTENTS DISCLOSED TO OUTSIDE PARTIES WITHOUT THE WRITTEN CONSENT OF TRANE

DRAWN BY: DK TRANE DATE: 03/25/11

DO NOT SCALE PRINT

THIRD ANGLE PROJECTION

177R0342 SHEET 1 OF 1 REV 001

DWG.SUBMITTAL,P2,BYPASS,TRANE

CLEARANCE REQUIREMENT FOR AIR FLOW COOLING:

THE UNIT MUST BE INSTALLED VERTICALLY WITH THE MINIMUM CLEARANCE OF 7.87" [200mm] ON THE BOTTOM AND 1.50" [38.1mm] ON EITHER SIDE FOR UNIT COOLING.

D
C
B
A

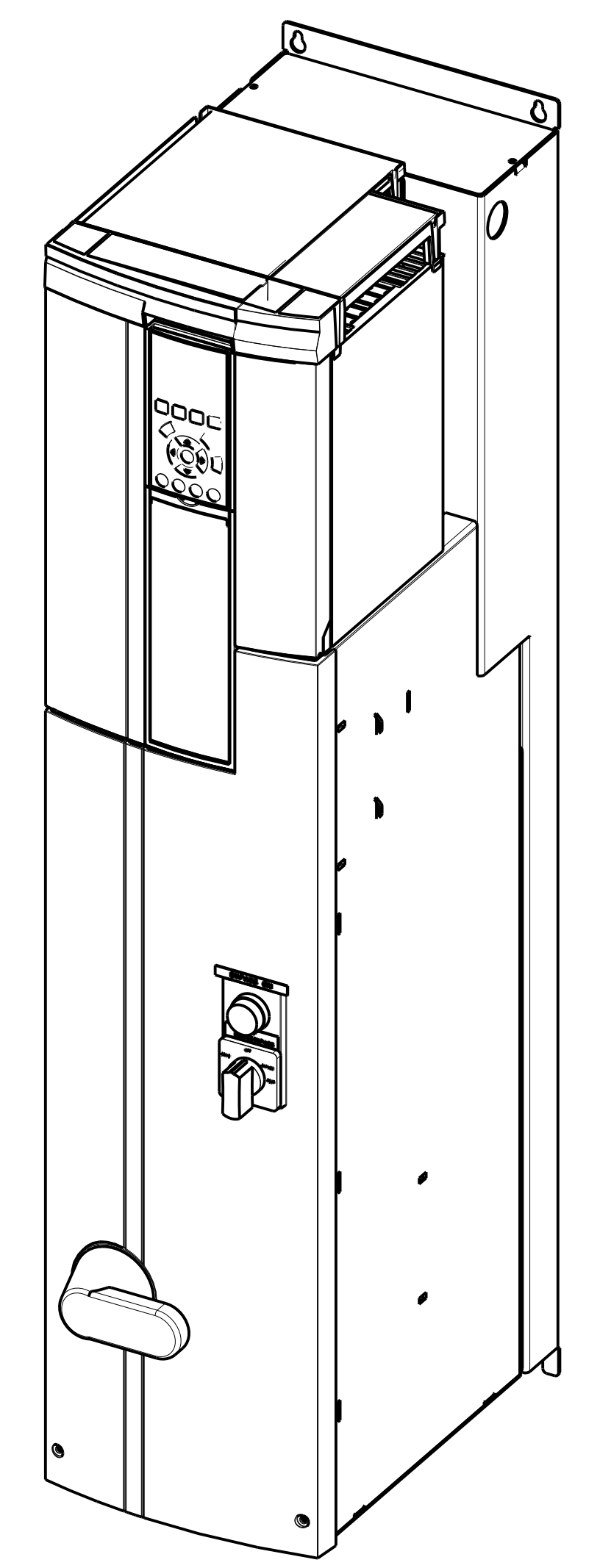
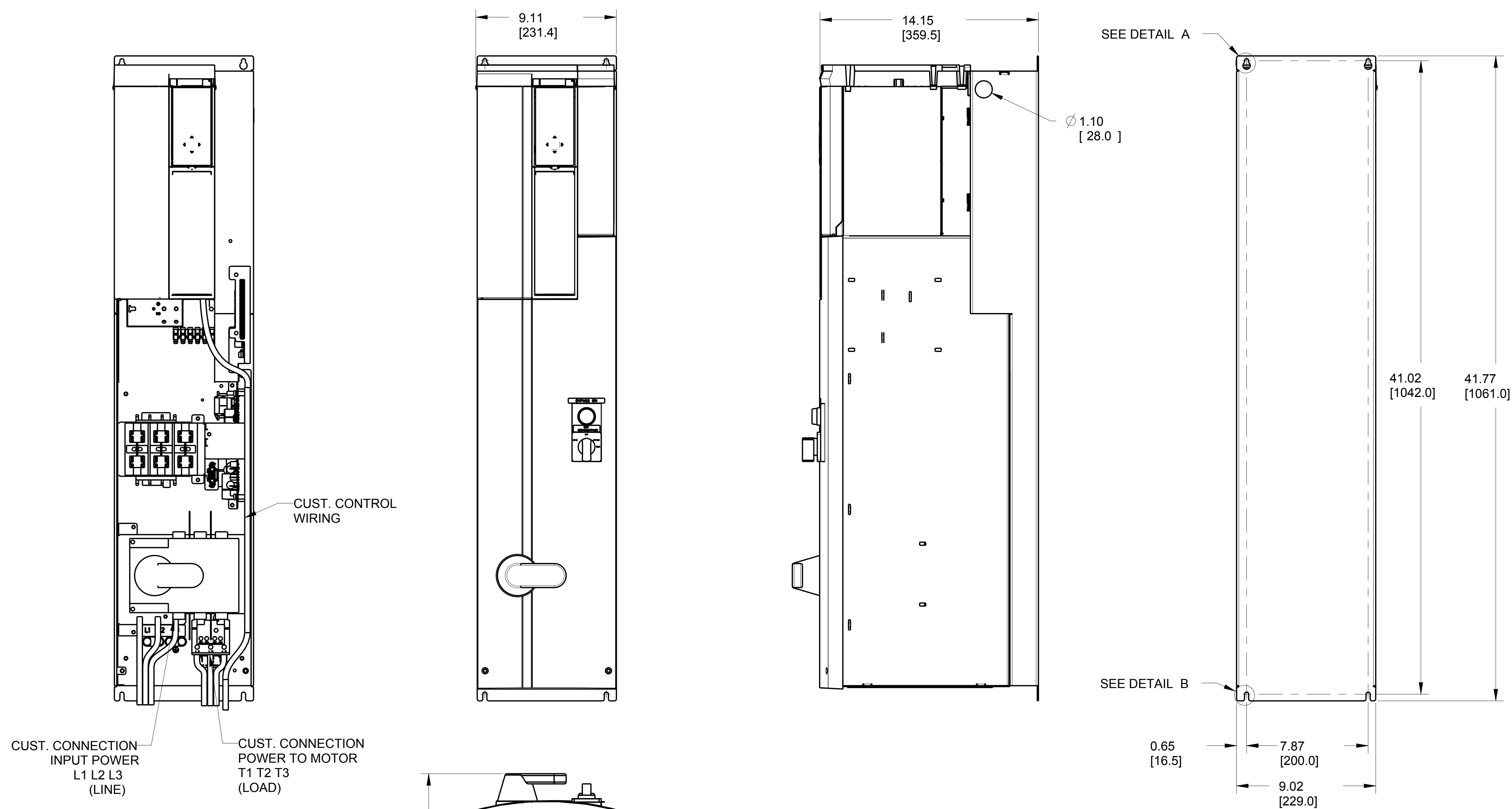

CUST. CONNECTION INPUT POWER L1 L2 L3 (LINE)

CUST. CONNECTION POWER TO MOTOR T1 T2 T3 (LOAD)

FRONT VIEW
FRONT COVER REMOVED

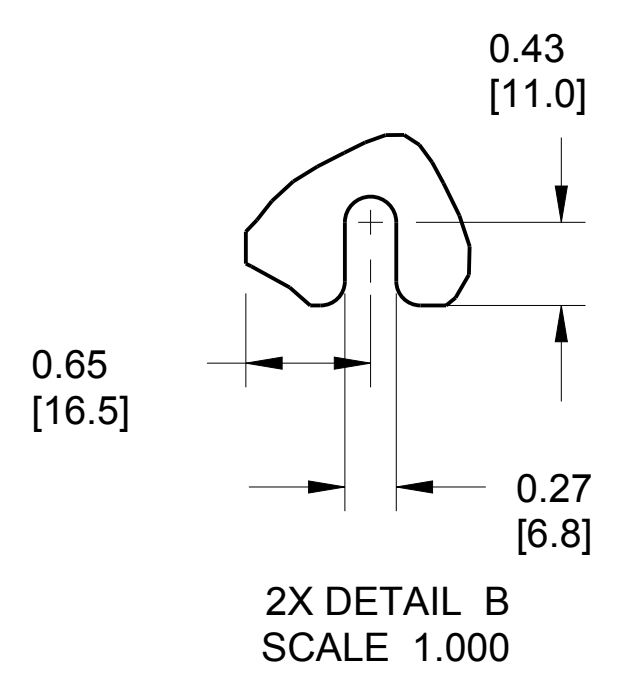
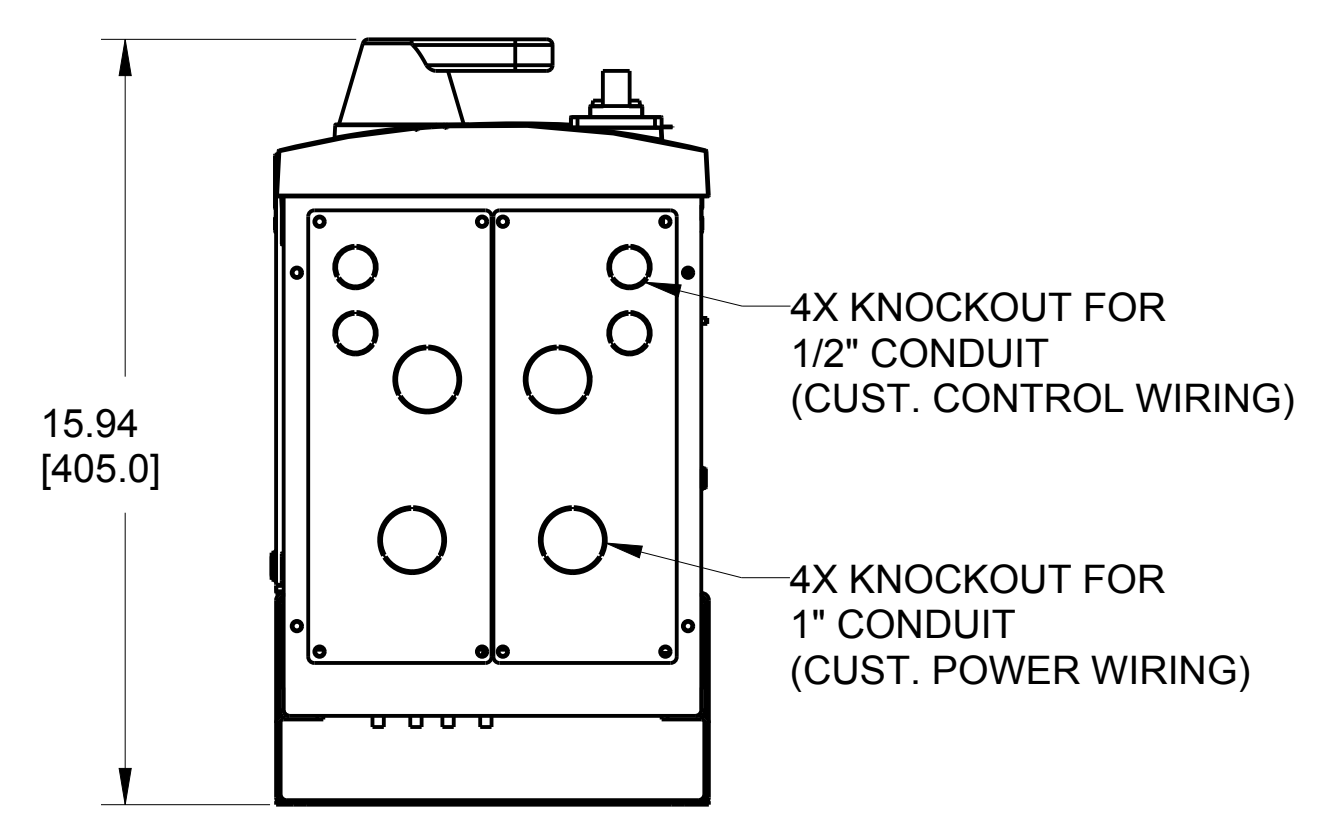
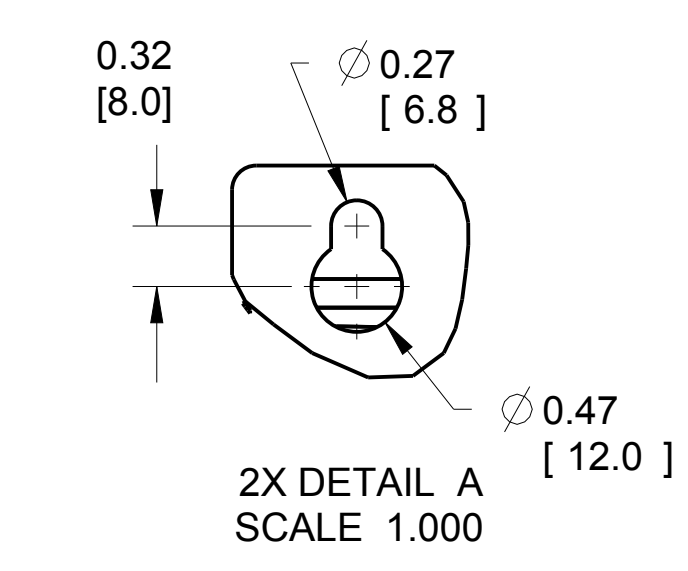

FRAME SIZE P2		
VOLTAGE	HP	KW
208	7.5	5.5
	10	7.5
	15	11
230	7.5	5.5
	10	7.5
	15	11
460	15	11
	20	15
	25	18
575	15	11
	20	15
	25	18

8 7 6 5 4 3 2 1