

DRAWING	REVISION	VERSION

UNLESS OTHERWISE SPECIFIED ALL DIMENSIONS ARE IN INCHES. TOLERANCE:

X ± 0.1
 XX ± 0.03
 XXX ± 0.005

ANGLES ± 2.0° HOLE DIA = +
 CONFORMS TO ASME Y14.5M-1994.

FINISH ✓

TRANE

THIS DRAWING IS PROPRIETARY AND SHALL NOT BE COPIED OR ITS CONTENTS DISCLOSED TO OUTSIDE PARTIES WITHOUT THE WRITTEN CONSENT OF TRANE

DRAWN BY: DK TRANE DATE: 03/28/11

DO NOT SCALE PRINT THIRD ANGLE PROJECTION

177R0347 SHEET 1 OF 1 REV 001

DWG.SUBMITTAL,P5,NONBYPASS,TRANE

CLEARANCE REQUIREMENT FOR AIR FLOW COOLING:
 THE UNIT MUST BE INSTALLED VERTICALLY WITH THE MINIMUM CLEARANCE OF 8.86" [225mm] ON THE BOTTOM AND 1.50" [38.1mm] ON EITHER SIDE FOR UNIT COOLING.

D

C

B

A

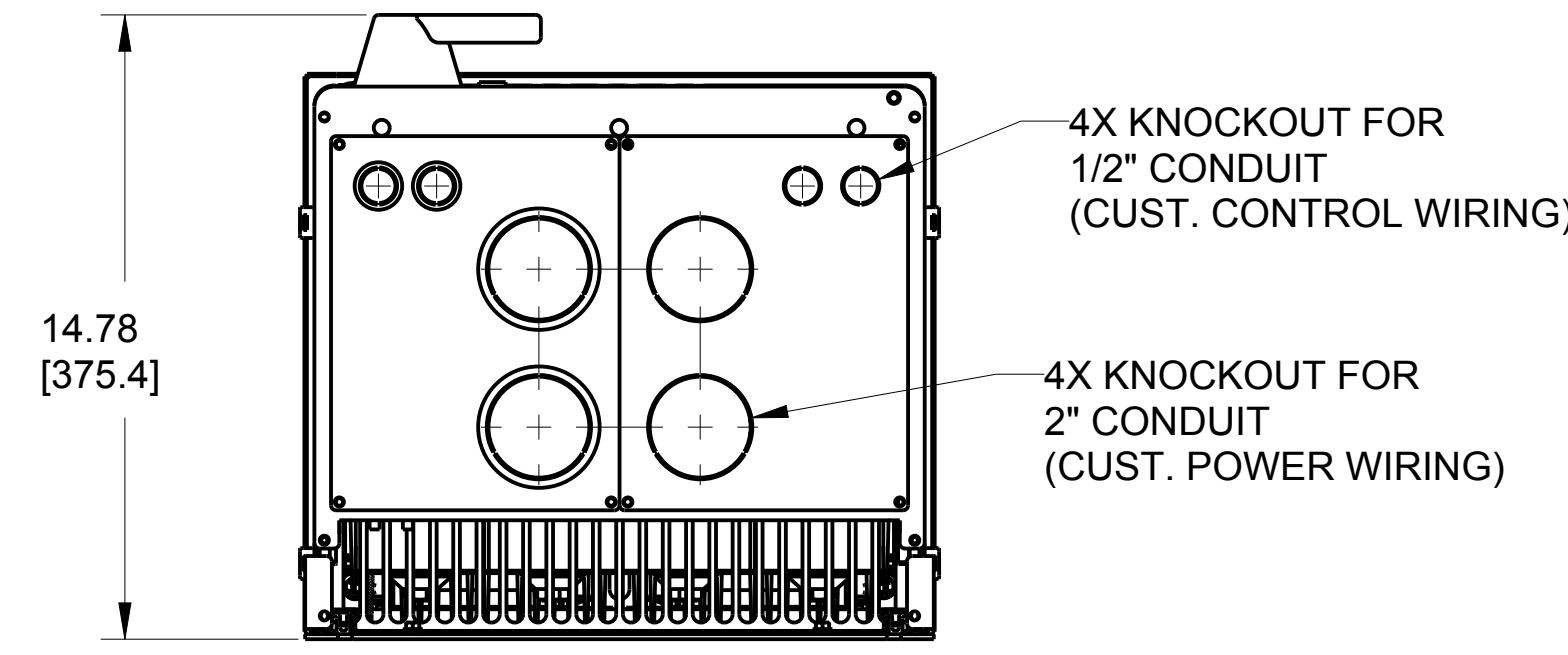
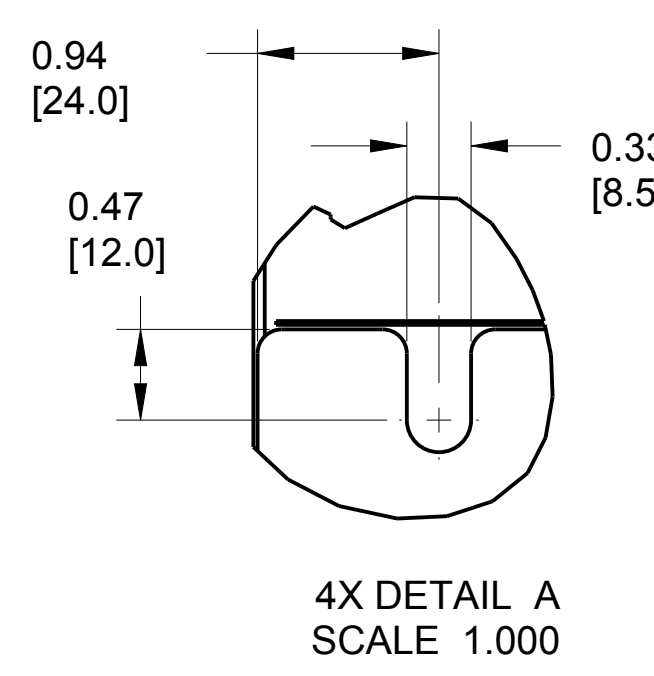
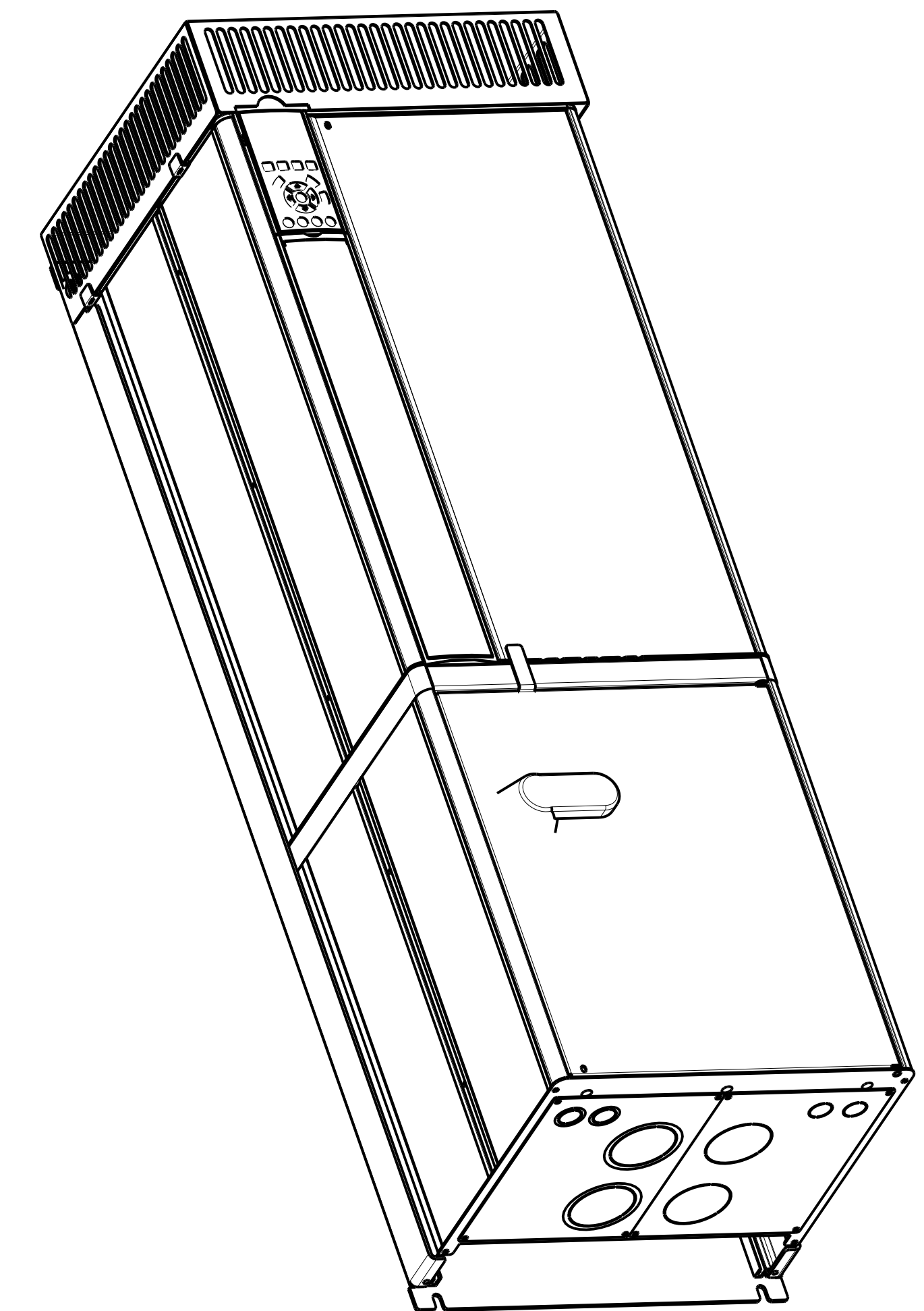
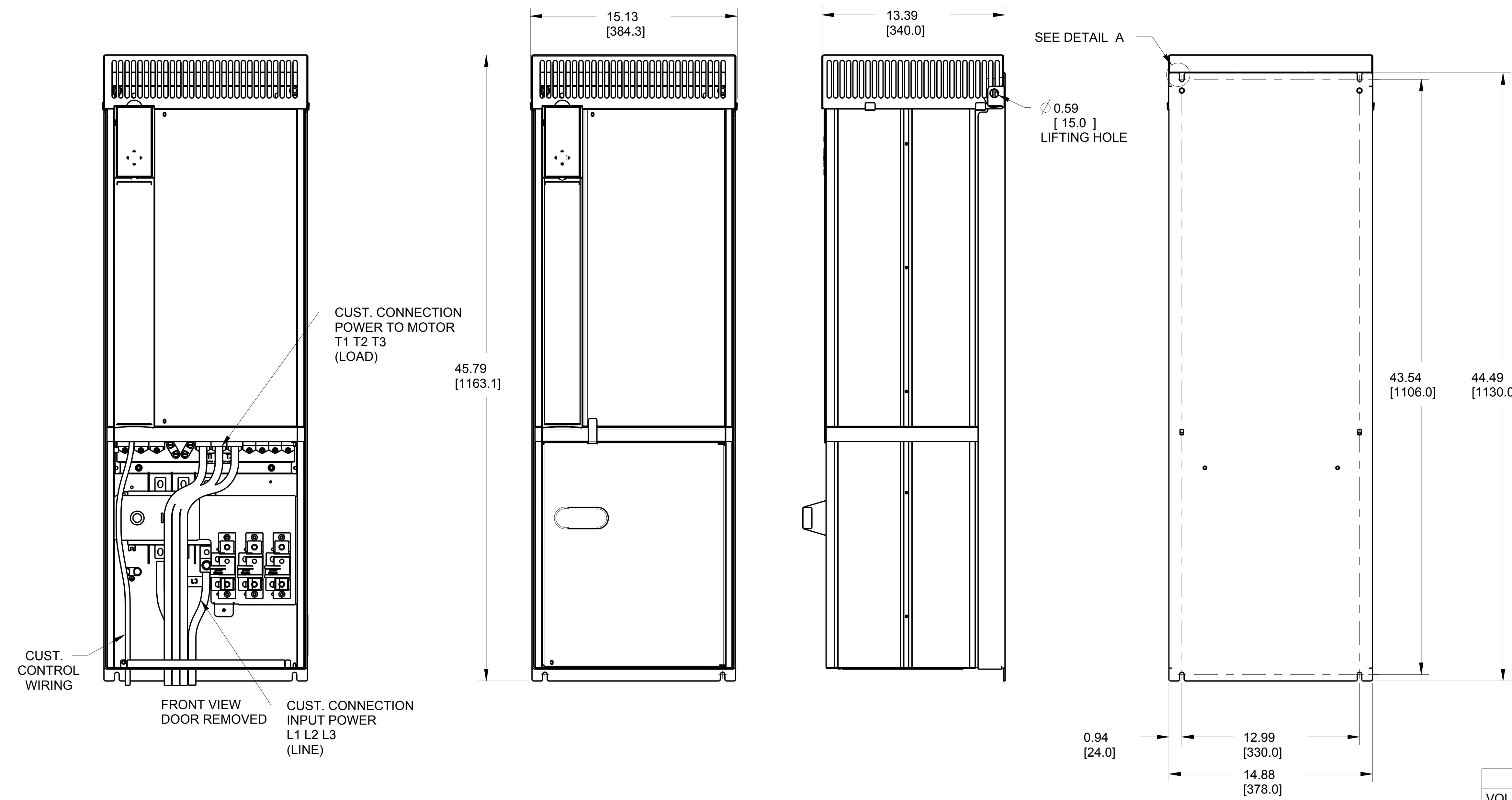

FRAME SIZE P5		
VOLTAGE	HP	KW
208	50	37
	60	45
230	50	37
	60	45
460	100	75
	125	90
575	100	75
	125	90