

WARNING!
 THE FOLLOWING TABLE LISTS THE PARAMETERS THAT ARE SET DIFFERENT FROM THE DRIVE DEFAULT SETTINGS. ADDITIONAL PARAMETER SETTINGS MAY BE REQUIRED FOR YOUR APPLICATION.

DRIVE PARAMETER SETTINGS

| PARAMETER # | NAME | SETTING | VALUE |
|-------------|-------------------|---------|----------------------|
| 0-02 | MOTOR SPEED UNIT | 1 | HZ |
| 0-03 | REGIONAL SETTINGS | 1 | NORTH AMERICA |
| 1-03 | TORQUE CHAR. | 3 | AUTO ENERGY OPTIM VT |
| 5-02 | TERMINAL 29 TYPE | 1 | OUTPUT |
| 5-11 | TERMINAL 19 | 52 | RUN PERMISSIVE |
| 5-31 | TERMINAL 29 | 5 | RUNNING |
| 5-40[0] | RELAY 1 | 160 | NO ALARM |
| 5-40[1] | RELAY 2 | 167 | START COMMAND |
| 14-20 | RESET MODE | 13 | INFINITE AUTO REST |

NOTES:

- * INDICATES COMPONENTS NOT SUPPLIED BY MANUFACTURER.
- REFER TO THE INSTALLATION AND OPERATION MANUAL FOR DRIVE FUNCTIONS AND PARAMETER SETTINGS.
- BRANCHCIRCUIT PROTECTION, INPUT POWER AND MOTOR WIRING MUST BE SELECTED IN ACCORDANCE WITH THE N.E.C., ANY APPLICATION LOCAL CODES AND THE LOAD CURRENT RATING.
- REPLACE JUMPER 'J1' WITH NORMALLY CLOSED SAFETY INTERLOCK CONTACT AS NECESSARY. CONTACT MUST BE RATED 1/4 HP @ 120VAC MINIMUM.
- PANEL MAY REQUIRE DERATING, CONSULT DRIVE MANUAL OR FACTORY FOR FOLLOWING CONDITIONS:
 - HIGHER SWITCHING FREQUENCY THAN DRIVE DEFAULT
 - HIGHER THAN PANEL LISTED AMBIENT TEMPERATURES
 - ELEVATION ABOVE 3300 FEET (1000 METERS)
 - LONG MOTOR LEAD LENGTHS

| | | | | | | | | | |
|-----|---------|-------|---|-----|--|------|------|--|----------------------------------|
| B | | | -NOTICE- THIS DRAWING IS PROPRIETARY AND SHALL NOT BE COPIED OR ITS CONTENTS DISCLOSED TO OUTSIDE PARTIES WITHOUT THE WRITTEN CONSENT OF THE TRANE COMPANY | DRN | NAME | | | THE TRANE COMPANY A DIVISION OF AMERICAN STANDARD INC. | |
| A | SP10119 | 11/10 | | DTM | NEMA 3R,208V,2C ,MAIN DISC, DRIVE FUSE ,3MB2,1R,SINGLE MOTOR,1 FAN | | | | |
| DR | SP10076 | 09/10 | | APR | MODEL | PAGE | SIZE | DWG NO. | TR200 1 OF 2 A 185B2343 |
| REV | ECN | DATE | | DTM | | | | | |

| WIRE COLOR SCHEME | |
|-------------------|---------------------------------|
| BLACK | - LINE VOLTAGE |
| RED | - AC CONTROL |
| WHITE | - AC GROUNDED CIRCUIT CONDUCTOR |
| BLUE | - DC CONTROL |
| GREEN | - CHASSIS GROUND |

| TERMINAL IDENTIFICATION | |
|-------------------------|---------------------|
| X | - DRIVE TERMINAL |
| ⊗ | - CUSTOMER TERMINAL |

CUSTOMER DRY CONTACT RATINGS

| RELAY | CONTACT RATING |
|-------------------------|---------------------------------|
| CR1, CR2, CR6, CR8, CR9 | 5A @ 120VAC 1/10 HP @ 120VAC |
| M2, M3 | 10A @ 120/240VAC |
| UV | 8A @ 120VAC 1/3 HP @ 120VAC |
| TD1 | 4A @ 250VAC |
| DRIVE REALY 1 & 2 | 2A @ 240VAC |

| CONTACT SEQUENCE CHART FOR S1 X INDICATES CONTACT CLOSED | | | | |
|---|----------|-------|-----|--------|
| CONTACT | POSITION | DRIVE | OFF | BYPASS |
| 13-14 | | | | X |
| 23-24 | | X | | |

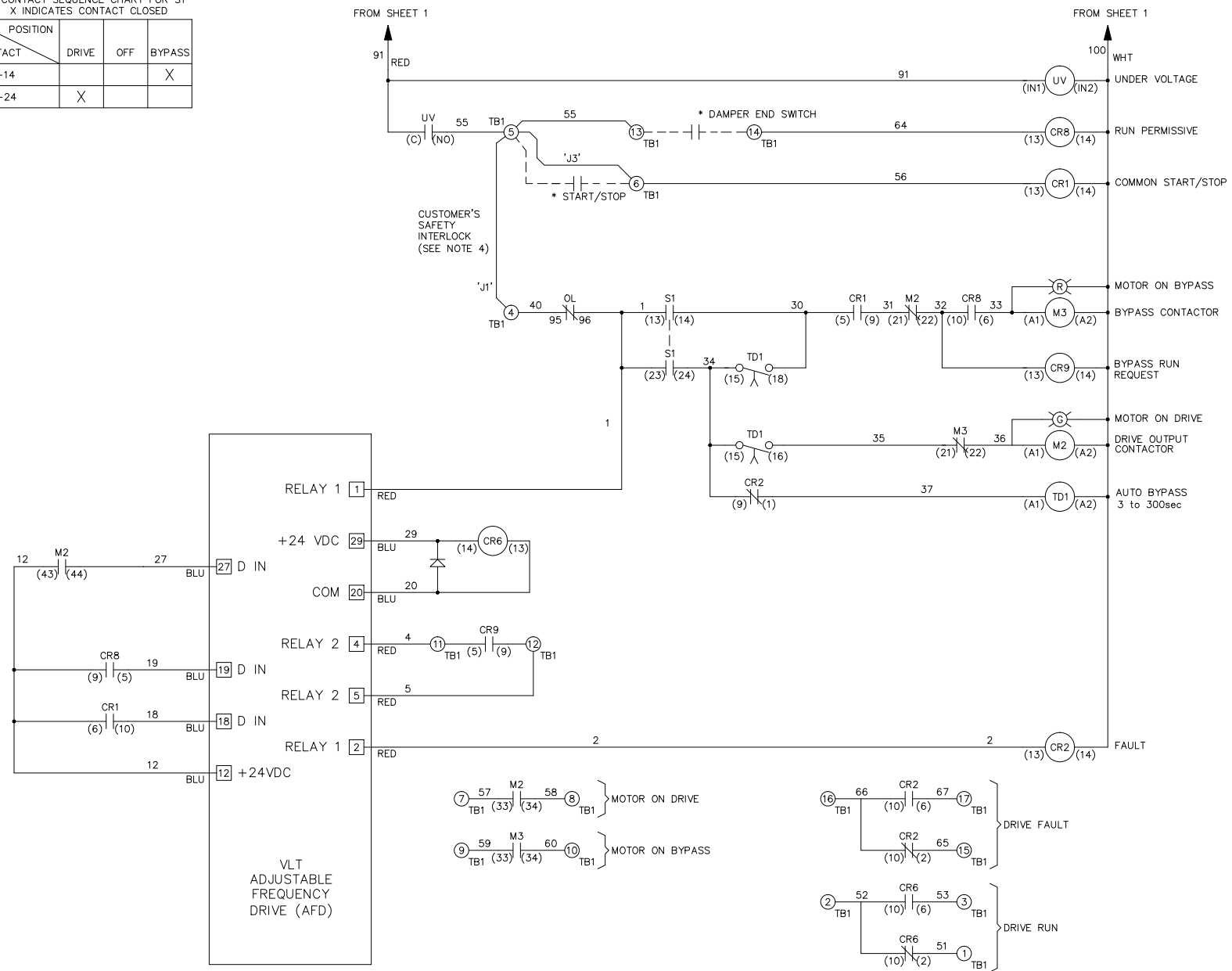

| | | |
|-----|---------|-------|
| B | | |
| A | SP10119 | 11/10 |
| DR | SP10076 | 09/10 |
| REV | ECN | DATE |

-NOTICE-

THIS DRAWING IS PROPRIETARY AND SHALL NOT BE COPIED OR ITS CONTENTS DISCLOSED TO OUTSIDE PARTIES WITHOUT THE WRITTEN CONSENT OF THE TRANE COMPANY

DRN
DTM

APR
DTM

NAME
NEMA 3R, 208V, 2C
, MAIN DISC, DRIVE FUSE
, 3MB2, IR, SINGLE MOTOR, 1 FAN

MODEL
TR200

PAGE 2 OF 2

SIZE
A

DWG NO. 185B2343

THE TRANE COMPANY
A DIVISION OF
AMERICAN STANDARD INC.