

**WARNING!**  
 THE FOLLOWING TABLE LISTS THE PARAMETERS THAT ARE SET DIFFERENT FROM THE DRIVE DEFAULT SETTINGS. ADDITIONAL PARAMETER SETTINGS MAY BE REQUIRED FOR YOUR APPLICATION.

DRIVE PARAMETER SETTINGS

PARAMETER #	NAME	SETTING	VALUE
0-02	MOTOR SPEED UNIT	1	HZ
0-03	REGIONAL SETTINGS	1	NORTH AMERICA
1-03	TORQUE CHAR.	1	VARIABLE TORQUE
5-02	TERMINAL 29 TYPE	1	OUTPUT
5-31	TERMINAL 29	5	RUNNING
14-20	RESET MODE	13	INFINITE AUTO REST

NOTES:

- \* INDICATES COMPONENTS NOT SUPPLIED BY MANUFACTURER.
- REFER TO THE INSTALLATION AND OPERATION MANUAL FOR DRIVE FUNCTIONS AND PARAMETER SETTINGS.
- BRANCHCIRCUIT PROTECTION, INPUT POWER AND MOTOR WIRING MUST BE SELECTED IN ACCORDANCE WITH THE N.E.C., ANY APPLICATION LOCAL CODES AND THE LOAD CURRENT RATING.
- REPLACE JUMPER 'J1' WITH NORMALLY CLOSED SAFETY INTERLOCK CONTACT AS NECESSARY. CONTACT MUST BE RATED 1/4 HP @ 120VAC MINIMUM.
- PANEL MAY REQUIRE DERATING, CONSULT DRIVE MANUAL OR FACTORY FOR FOLLOWING CONDITIONS:
  - HIGHER SWITCHING FREQUENCY THAN DRIVE DEFAULT
  - HIGHER THAN PANEL LISTED AMBIENT TEMPERATURES
  - ELEVATION ABOVE 3300 FEET (1000 METERS)
  - LONG MOTOR LEAD LENGTHS
- WHEN MOTOR OVERLOADS SIZES ARE DIFFERENT, MOTOR 1 WILL BE THE LARGER OF THE TWO MOTORS

B			-NOTICE- THIS DRAWING IS PROPRIETARY AND SHALL NOT BE COPIED OR ITS CONTENTS DISCLOSED TO OUTSIDE PARTIES WITHOUT THE WRITTEN CONSENT OF THE TRANE COMPANY	DRN	NAME NEMA 3R,600V,2C ,MAIN & DRIVE DISC, DRIVE FUSE ,3MB1,IR,DUAL MOTOR,1 FAN				THE TRANE COMPANY A DIVISION OF AMERICAN STANDARD INC.	
A	SP10119	11/10		DTM	APR	MODEL	TR200	PAGE 1 OF 2	SIZE A	DWG NO. 185B3094
DR	SP10076	09/10		DTM						
REV	ECN	DATE								

WIRE COLOR SCHEME  
 BLACK - LINE VOLTAGE  
 RED - AC CONTROL  
 WHITE - AC GROUNDED  
 CIRCUIT CONDUCTOR  
 BLUE - DC CONTROL  
 GREEN - CHASSIS GROUND

TERMINAL IDENTIFICATION

(X) - DRIVE TERMINAL  
 (X) - CUSTOMER TERMINAL

CUSTOMER DRY CONTACT RATINGS

RELAY	CONTACT RATING
CR1, CR6	5A @ 120VAC 1/10 HP @ 120VAC
M2, M3	10A @ 120/240VAC

CONTACT SEQUENCE CHART FOR S1  
 X INDICATES CONTACT CLOSED

POSITION	DRIVE	OFF	BYPASS
13-14			X
23-24	X		

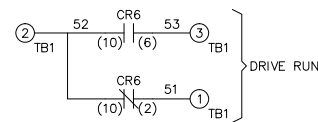
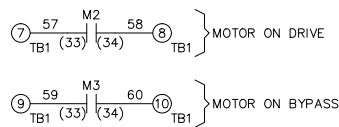
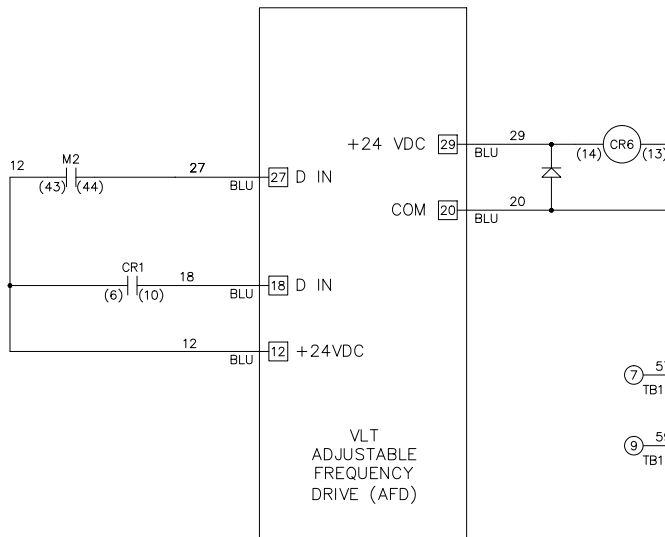

B			<p align="center">-NOTICE-</p> <p>THIS DRAWING IS PROPRIETARY AND SHALL NOT BE COPIED OR ITS CONTENTS DISCLOSED TO OUTSIDE PARTIES WITHOUT THE WRITTEN CONSENT OF THE TRANE COMPANY</p>	DRN <i>DTM</i>	NAME NEMA 3R,600V,2C ,MAIN & DRIVE DISC, DRIVE FUSE ,3MB1,IR,DUAL MOTOR,1 FAN			THE TRANE COMPANY A DIVISION OF AMERICAN STANDARD INC.		
A	SP10119	11/10		APR <i>DTM</i>	MODEL TR200	PAGE 2 OF 2	SIZE A	DWG NO. 185B3094		
DR	SP10076	09/10								
REV	ECN	DATE								