

WIRE COLOR SCHEME		TERMINAL IDENTIFICATION	
BLACK	- LINE VOLTAGE	<span style="border: 1px solid black; padding: 0 2px;">X</span>	- DRIVE TERMINAL
RED	- AC CONTROL	<span style="border: 1px solid black; border-radius: 50%; padding: 0 2px;">X</span>	- CUSTOMER TERMINAL
WHITE	- AC GROUNDED CIRCUIT CONDUCTOR		
BLUE	- DC CONTROL		
GREEN	- CHASSIS GROUND		

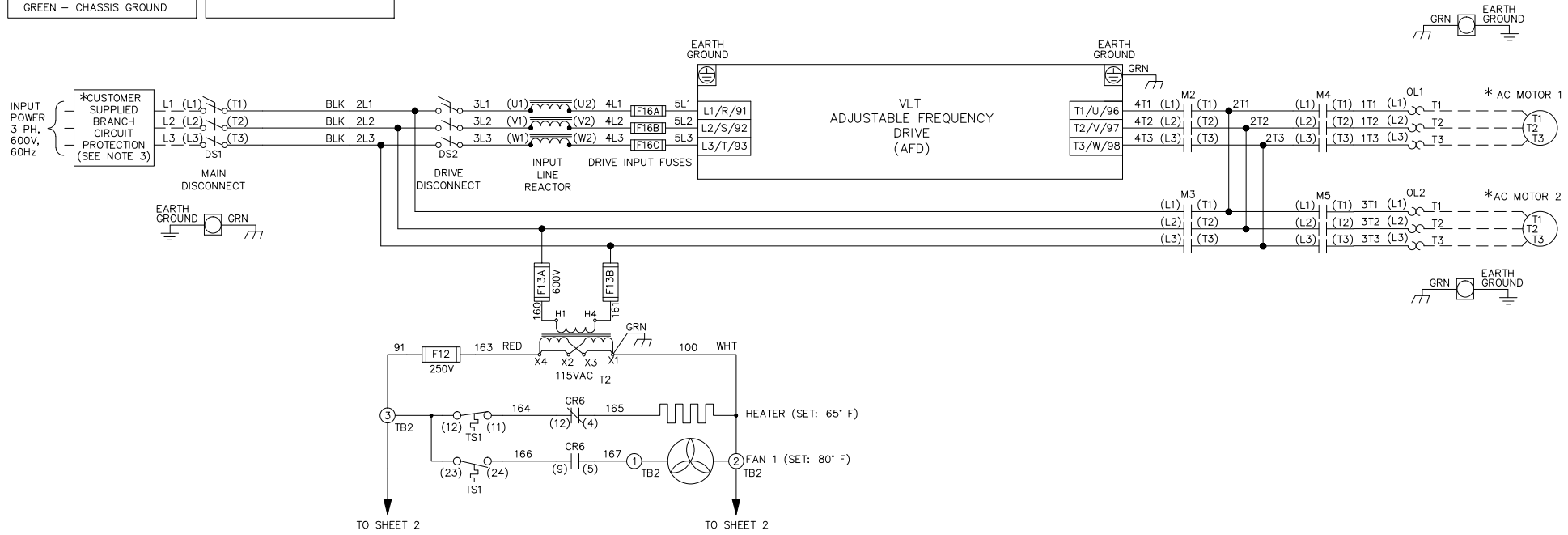

**WARNING!**  
THE FOLLOWING TABLE LISTS THE PARAMETERS THAT ARE SET DIFFERENT FROM THE DRIVE DEFAULT SETTINGS. ADDITIONAL PARAMETER SETTINGS MAY BE REQUIRED FOR YOUR APPLICATION.

DRIVE PARAMETER SETTINGS

PARAMETER #	NAME	SETTING	VALUE
0-02	MOTOR SPEED UNIT	1	HZ
0-03	REGIONAL SETTINGS	1	NORTH AMERICA
1-03	TORQUE CHAR.	3	AUTO ENERGY OPTIM VT
5-02	TERMINAL 29 TYPE	1	OUTPUT
5-31	TERMINAL 29	5	RUNNING
14-20	RESET MODE	13	INFINITE AUTO REST

NOTES:

1. \* INDICATES COMPONENTS NOT SUPPLIED BY MANUFACTURER.
2. REFER TO THE INSTALLATION AND OPERATION MANUAL FOR DRIVE FUNCTIONS AND PARAMETER SETTINGS.
3. BRANCHCIRCUIT PROTECTION, INPUT POWER AND MOTOR WIRING MUST BE SELECTED IN ACCORDANCE WITH THE N.E.C., ANY APPLICATION LOCAL CODES AND THE LOAD CURRENT RATING.
4. REPLACE JUMPER 'J1' WITH NORMALLY CLOSED SAFETY INTERLOCK CONTACT AS NECESSARY. CONTACT MUST BE RATED 1/4 HP @ 120VAC MINIMUM.
5. PANEL MAY REQUIRE DERATING, CONSULT DRIVE MANUAL OR FACTORY FOR FOLLOWING CONDITIONS:
  - 5.1. HIGHER SWITCHING FREQUENCY THAN DRIVE DEFAULT
  - 5.2. HIGHER THAN PANEL LISTED AMBIENT TEMPERATURES
  - 5.3. ELEVATION ABOVE 3300 FEET (1000 METERS)
  - 5.4. LONG MOTOR LEAD LENGTHS

B			-NOTICE-	DRN	NAME			
A	SP10119	11/10	THIS DRAWING IS PROPRIETARY AND SHALL NOT BE COPIED OR ITS CONTENTS DISCLOSED TO OUTSIDE PARTIES WITHOUT THE WRITTEN CONSENT OF THE TRANE COMPANY	DTM	NEMA 3R,600V,2C	THE TRANE COMPANY A DIVISION OF AMERICAN STANDARD INC.		
DR	SP10076	09/10		APR	,MAIN & DRIVE DISC, DRIVE FUSE			
REV	ECN	DATE		DTM	,3MB1,IR,CONTACT MOTOR SELECT,1 FAN	MODEL	PAGE 1 OF 2	SIZE A

WIRE COLOR SCHEME  
 BLACK - LINE VOLTAGE  
 RED - AC CONTROL  
 WHITE - AC GROUNDED  
 CIRCUIT CONDUCTOR  
 BLUE - DC CONTROL  
 GREEN - CHASSIS GROUND

TERMINAL IDENTIFICATION  
 [X] - DRIVE TERMINAL  
 (X) - CUSTOMER TERMINAL

CUSTOMER DRY CONTACT RATINGS

RELAY	CONTACT RATING
CR1, CR6	5A @ 120VAC 1/10 HP @ 120VAC
M2, M3, M4, M5	10A @ 120/240VAC

CONTACT SEQUENCE CHART FOR S1  
 X INDICATES CONTACT CLOSED

POSITION	DRIVE	OFF	BYPASS
CONTACT 13-14			X
CONTACT 23-24	X		

CONTACT SEQUENCE CHART FOR S2  
 X INDICATES CONTACT CLOSED

POSITION	MOTOR 1	AUTO	MOTOR 2
CONTACT 11-12	X	X	
CONTACT 13-14			X
CONTACT 21-22		X	X
CONTACT 23-24	X		



B		
A	SP10119	11/10
DR	SP10076	09/10
REV	ECN	DATE

-NOTICE-  
 THIS DRAWING IS PROPRIETARY AND SHALL NOT BE COPIED OR ITS CONTENTS DISCLOSED TO OUTSIDE PARTIES WITHOUT THE WRITTEN CONSENT OF THE TRANE COMPANY

DRN DTM  
 APR DTM

NAME NEMA 3R,600V,2C  
 ,MAIN & DRIVE DISC, DRIVE FUSE  
 ,3MB1,IR,CONTACT MOTOR SELECT,1 FAN

THE TRANE COMPANY  
 A DIVISION OF  
 AMERICAN STANDARD INC.

MODEL TR200 PAGE 2 OF 2 SIZE A DWG NO. 185B3095