



WIRE COLOR SCHEME	
BLACK	- LINE VOLTAGE
RED	- AC CONTROL
WHITE	- AC GROUNDED CIRCUIT CONDUCTOR
BLUE	- DC CONTROL
GREEN	- CHASSIS GROUND

TERMINAL IDENTIFICATION	
<span style="border: 1px solid black; padding: 0 2px;">X</span>	- DRIVE TERMINAL
<span style="border: 1px solid black; border-radius: 50%; padding: 0 2px;">X</span>	- CUSTOMER TERMINAL

CUSTOMER DRY CONTACT RATINGS

RELAY	CONTACT RATING
CR1, CR2, CR6, CR8, CR9	5A @ 120VAC 1/10 HP @ 120VAC
M2, M3	10A @ 120/240VAC
UV	8A @ 120VAC 1/3 HP @ 120VAC
TD1	4A @ 250VAC
DRIVE REALY 1 & 2	2A @ 240VAC

CONTACT SEQUENCE CHART FOR S1 X INDICATES CONTACT CLOSED				
CONTACT	POSITION	DRIVE	OFF	BYPASS
13-14				X
23-24		X		

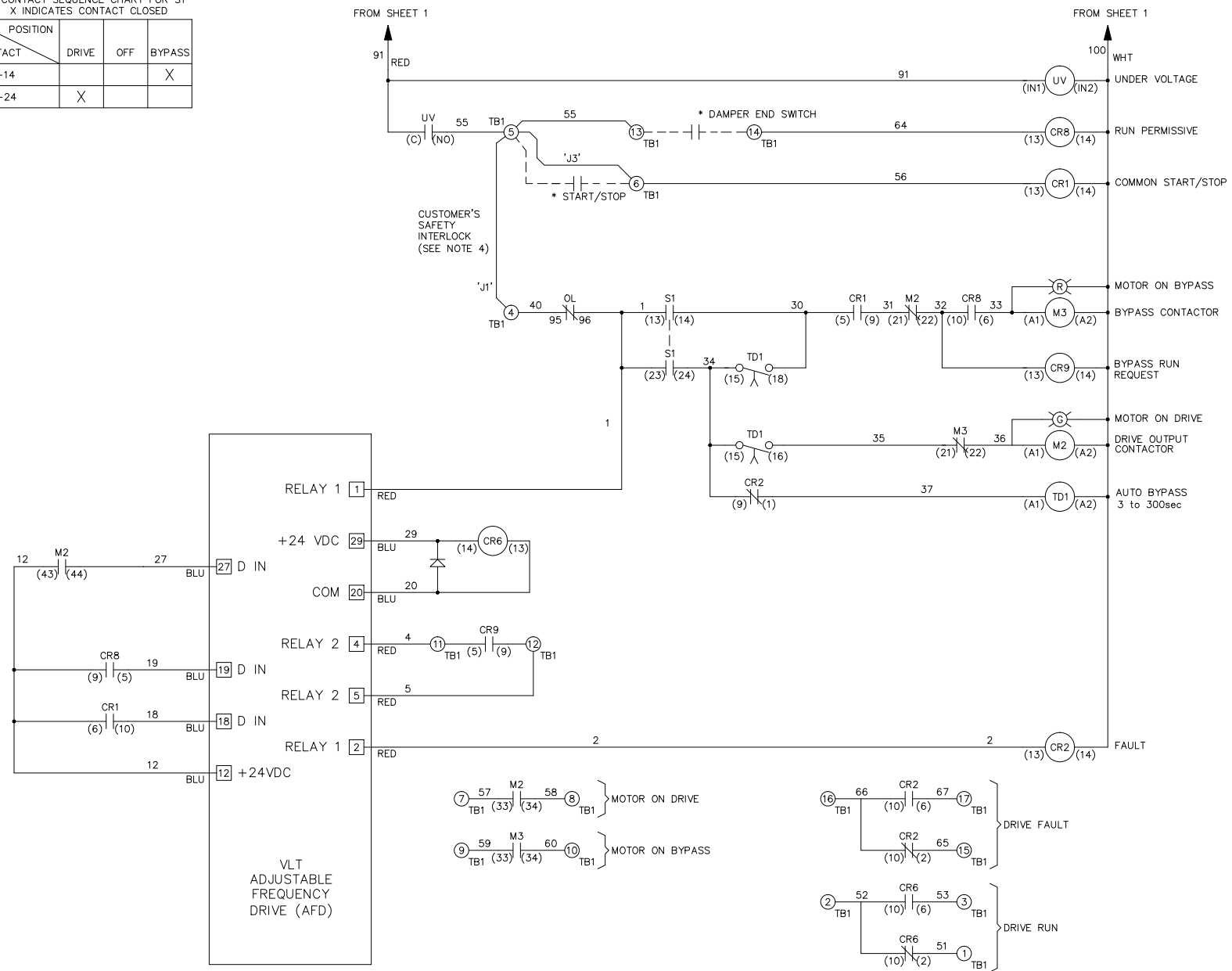

B		
A	SP10119	11/10
DR	SP10076	09/10
REV	ECN	DATE

-NOTICE-

THIS DRAWING IS PROPRIETARY AND SHALL NOT BE COPIED OR ITS CONTENTS DISCLOSED TO OUTSIDE PARTIES WITHOUT THE WRITTEN CONSENT OF THE TRANE COMPANY

DRN  
*DTM*

APR  
*DTM*

NAME  
NEMA 3R,600V,2C  
,MAIN & DRIVE DISC, MAIN & DRIVE FUSE  
,3MB2,IR,SINGLE MOTOR,1 FAN

MODEL  
TR200

PAGE 2 OF 2

SIZE  
A

DWG NO.  
185B3135

**THE TRANE COMPANY**  
A DIVISION OF  
AMERICAN STANDARD INC.