

WARNING!
 THE FOLLOWING TABLE LISTS THE PARAMETERS THAT ARE SET DIFFERENT FROM THE DRIVE DEFAULT SETTINGS. ADDITIONAL PARAMETER SETTINGS MAY BE REQUIRED FOR YOUR APPLICATION.

DRIVE PARAMETER SETTINGS

| PARAMETER # | NAME | SETTING | VALUE |
|-------------|-------------------|---------|----------------------|
| 0-02 | MOTOR SPEED UNIT | 1 | HZ |
| 0-03 | REGIONAL SETTINGS | 1 | NORTH AMERICA |
| 1-03 | TORQUE CHAR. | 3 | AUTO ENERGY OPTIM VT |
| 5-02 | TERMINAL 29 TYPE | 1 | OUTPUT |
| 5-31 | TERMINAL 29 | 5 | RUNNING |
| 14-20 | RESET MODE | 13 | INFINITE AUTO REST |

- NOTES:
- * INDICATES COMPONENTS NOT SUPPLIED BY MANUFACTURER.
 - REFER TO THE INSTALLATION AND OPERATION MANUAL FOR DRIVE FUNCTIONS AND PARAMETER SETTINGS.
 - BRANCHCIRCUIT PROTECTION, INPUT POWER AND MOTOR WIRING MUST BE SELECTED IN ACCORDANCE WITH THE N.E.C., ANY APPLICATION LOCAL CODES AND THE LOAD CURRENT RATING.
 - REPLACE JUMPER 'J1' WITH NORMALLY CLOSED SAFETY INTERLOCK CONTACT AS NECESSARY. CONTACT MUST BE RATED 1/4 HP @ 120VAC MINIMUM.
 - PANEL MAY REQUIRE DERATING, CONSULT DRIVE MANUAL OR FACTORY FOR FOLLOWING CONDITIONS:
 - HIGHER SWITCHING FREQUENCY THAN DRIVE DEFAULT
 - HIGHER THAN PANEL LISTED AMBIENT TEMPERATURES
 - ELEVATION ABOVE 3300 FEET (1000 METERS)
 - LONG MOTOR LEAD LENGTHS

| | | | | | | | | | |
|-----|---------|-------|---|-----|--|--------|------|--|--|
| B | | | -NOTICE- THIS DRAWING IS PROPRIETARY AND SHALL NOT BE COPIED OR ITS CONTENTS DISCLOSED TO OUTSIDE PARTIES WITHOUT THE WRITTEN CONSENT OF THE TRANE COMPANY | DRN | NAME | | | THE TRANE COMPANY A DIVISION OF AMERICAN STANDARD INC. | |
| A | SP10119 | 11/10 | | DTM | NEMA 3R,480V,2C ,MAIN & DRIVE DISC, DRIVE FUSE ,3MB,CONTACT MOTOR SELECT,2 FAN | | | | |
| DR | SP10076 | 09/10 | | APR | MODEL | PAGE | SIZE | 185B3644 | |
| REV | ECN | DATE | | DTM | TR200 | 1 OF 2 | A | | |

WIRE COLOR SCHEME
 BLACK - LINE VOLTAGE
 RED - AC CONTROL
 WHITE - AC GROUNDED
 CIRCUIT CONDUCTOR
 BLUE - DC CONTROL
 GREEN - CHASSIS GROUND

TERMINAL IDENTIFICATION
 [X] - DRIVE TERMINAL
 (X) - CUSTOMER TERMINAL

CUSTOMER DRY CONTACT RATINGS

| RELAY | CONTACT RATING |
|-------------------|---------------------------------|
| CR6 | 5A @ 120VAC 1/10 HP @ 120VAC |
| M2, M3, M4, M5 | 10A @ 120/240VAC |

CONTACT SEQUENCE CHART FOR S1
X INDICATES CONTACT CLOSED

| POSITION | DRIVE | OFF | BYPASS |
|---------------|-------|-----|--------|
| CONTACT 13-14 | | | X |
| CONTACT 23-24 | X | | |

CONTACT SEQUENCE CHART FOR S2
X INDICATES CONTACT CLOSED

| POSITION | MOTOR 1 | AUTO | MOTOR 2 |
|---------------|---------|------|---------|
| CONTACT 11-12 | X | X | |
| CONTACT 13-14 | | | X |
| CONTACT 21-22 | | X | X |
| CONTACT 23-24 | X | | |

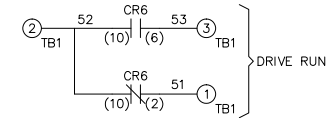
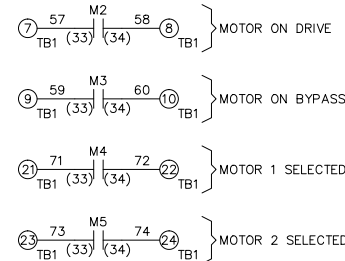
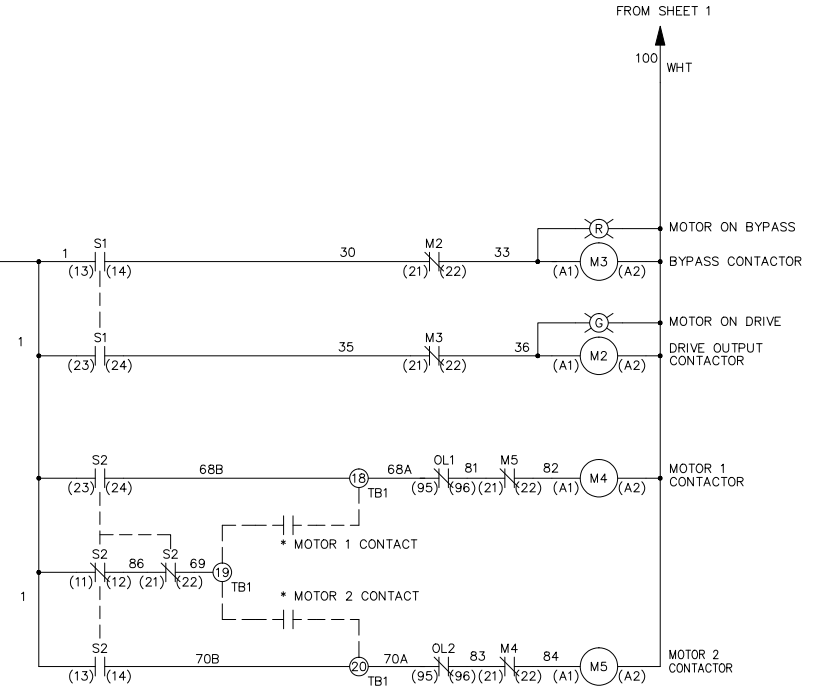
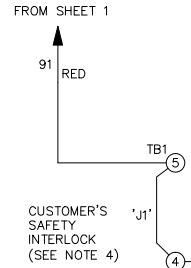

| | | | | | | | | | |
|-----|---------|-------|---|-----|--|--------|------|---|--|
| B | | | -NOTICE- THIS DRAWING IS PROPRIETARY AND SHALL NOT BE COPIED OR ITS CONTENTS DISCLOSED TO OUTSIDE PARTIES WITHOUT THE WRITTEN CONSENT OF THE TRANE COMPANY | DRN | NAME | | | THE TRANE COMPANY A DIVISION OF AMERICAN STANDARD INC. | |
| A | SP10119 | 11/10 | | DTM | NEMA 3R, 480V, 2C ,MAIN & DRIVE DISC, DRIVE FUSE ,3MB, CONTACT MOTOR SELECT, 2 FAN | | | | |
| DR | SP10076 | 09/10 | | APR | MODEL | PAGE | SIZE | DWG NO. | |
| REV | ECN | DATE | | DTM | TR200 | 2 OF 2 | A | 185B3644 | |