



| WIRE COLOR SCHEME |                                 |
|-------------------|---------------------------------|
| BLACK             | - LINE VOLTAGE                  |
| RED               | - AC CONTROL                    |
| WHITE             | - AC GROUNDED CIRCUIT CONDUCTOR |
| BLUE              | - DC CONTROL                    |
| GREEN             | - CHASSIS GROUND                |

| TERMINAL IDENTIFICATION   |                     |
|---|---------------------|
| <span style="border: 1px solid black; padding: 0 2px;">X</span>                     | - DRIVE TERMINAL    |
| <span style="border: 1px solid black; border-radius: 50%; padding: 0 2px;">X</span> | - CUSTOMER TERMINAL |

CUSTOMER DRY CONTACT RATINGS

| RELAY                   | CONTACT RATING                  |
|-------------------------|---------------------------------|
| CR1, CR2, CR6, CR8, CR9 | 5A @ 120VAC<br>1/10 HP @ 120VAC |
| M2, M3                  | 10A @ 120/240VAC                |
| UV                      | 8A @ 120VAC<br>1/3 HP @ 120VAC  |
| TD1                     | 4A @ 250VAC                     |
| DRIVE RELAY 1 & 2       | 2A @ 240VAC                     |

| CONTACT SEQUENCE CHART FOR S1<br>X INDICATES CONTACT CLOSED |          |       |     |        |
|---|----------|-------|-----|--------|
| CONTACT   | POSITION | DRIVE | OFF | BYPASS |
| 13-14   |          |       |     | X      |
| 23-24   |          | X     |     |        |

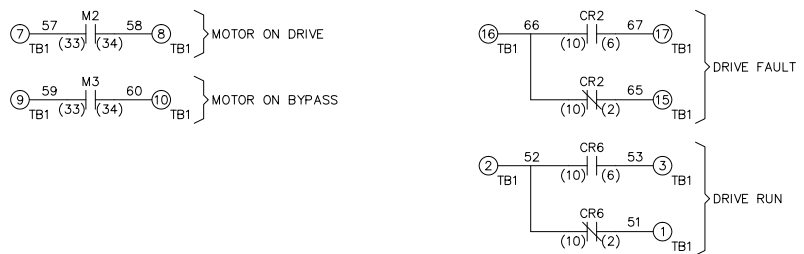
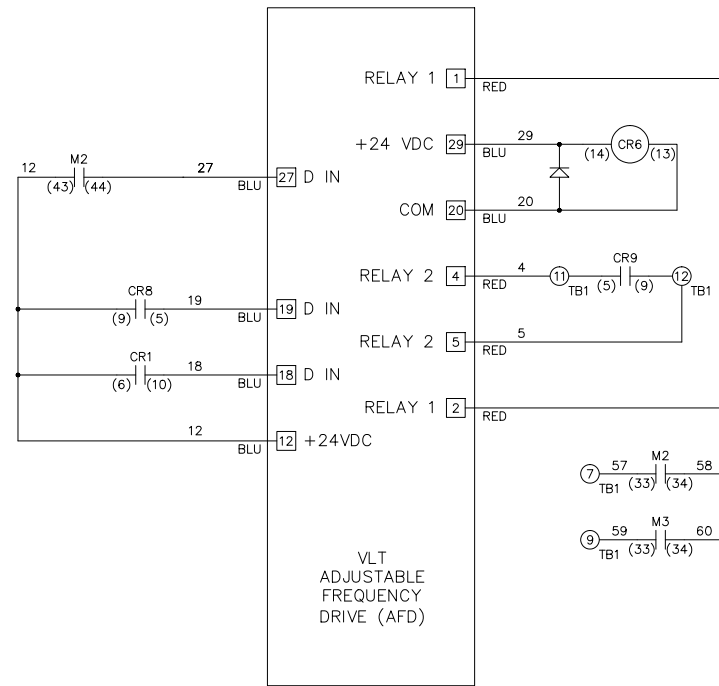

|     |         |       |
|-----|---------|-------|
| B   |         |       |
| A   | SP10119 | 11/10 |
| DR  | SP10076 | 09/10 |
| REV | ECN     | DATE  |

-NOTICE-

THIS DRAWING IS PROPRIETARY AND SHALL NOT BE COPIED OR ITS CONTENTS DISCLOSED TO OUTSIDE PARTIES WITHOUT THE WRITTEN CONSENT OF THE TRANE COMPANY

DRN  
*DTM*

APR  
*DTM*

NAME  
NEMA 3R,208V,2C  
, MAIN DISC, MAIN & DRIVE FUSE  
,3MB2,IR,DUAL MOTOR,4 FAN

MODEL  
TR200

PAGE 2 OF 2

SIZE **A**

DWG NO. **185B3970**

**THE TRANE COMPANY**  
A DIVISION OF  
AMERICAN STANDARD INC.