

Danfoss

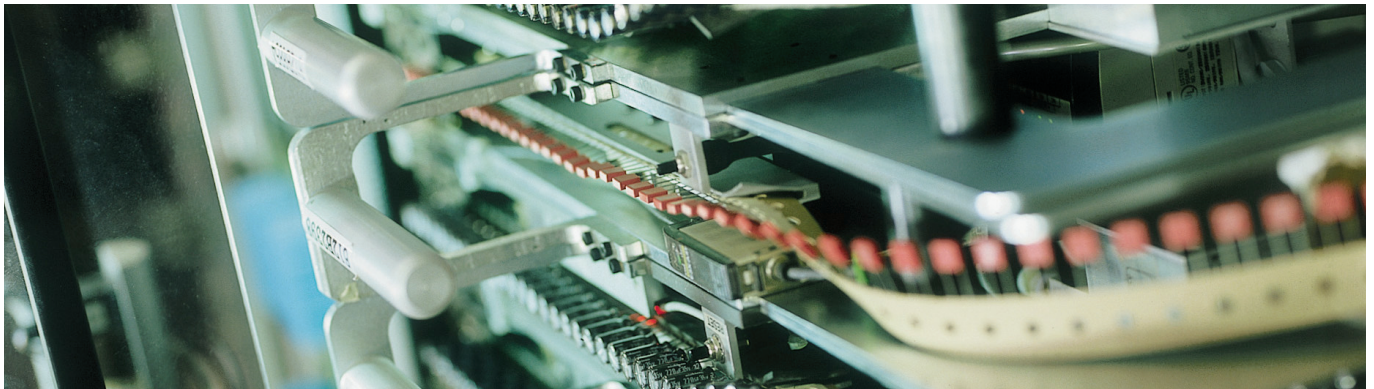

Danfoss Drives
VLT® Product Catalogue

The leading provider of Drives



Two thousand employees headed from Graasten in Denmark develop, manufacture, sell and service electronic motor controls in more than one hundred countries.

Manufacturing takes place in USA – Especially the high power products – and in Asia, but the major production takes place in the plants in Graasten, where half of the staff are employed. Danfoss Bauer geared motors are manufactured in Esslingen, Germany.

The success of Danfoss is due to the strong combination of technology and application knowledge throughout the world combined with a highly sophisticated set-up of product development, supply chain, logistics and on site presence anywhere on the globe.

Our customers are closely involved during every stage of design and development, specifying their needs in terms of features and user interface. Danfoss Drives dedicates itself to every step in every process until the customer has the drive in hand.

The developers at Danfoss Drives have fully adopted modular principles in development as well as design, production and configuration. Each function is developed in parallel on dedicated technology platforms and interfaces between the elements are carefully defined. This allows development to take place for each element in parallel, reducing time to market and ensuring that customers always enjoy the benefits of recently developed features.

This unique modular concept is also the basis for a highly automated quality manufacturing process, where Danfoss Drives takes responsibility for every element – starting with the essential semi conductor power modules. Power Modules are produced in Danfoss Silicon Power in Schleswig, Germany. High quality standards and efficient manufacturing facilities makes Danfoss Silicon Power modules in great demand within industries that provide highly automated power-applications like the automotive sector.

When it comes to quality, delivery and cooperation, Danfoss makes high demands on their suppliers – both from inside and outside of the group.

Due to an unsurpassed level of automation Danfoss can produce a customer configured drive from 1.6 million possible configurations in a manufacturing time of two hours. The unique string code that fully defines the drive can easily be obtained throughout the world by use of the internet; it determines the configuration of all elements of the drive, both electronics and hardware. Once this unique configuration is passed to the production departments the manufacturing process can begin, testing is carried out at all stages of the process and begins with optical checks of the PCBs to ensure that components are inserted correctly, once the PCBs are fully assembled they all must pass an automatic in circuit test. After assembly is complete all drives are fully tested on motor loads.

During the drives manufacturing cycle the correct manual is being printed and made available for packing. By the use of this process we ensure that not only the correct language but the very latest version of the manual is always produced and shipped with the correct drive. Just in time delivery is a reality.

Once the drive is shipped one of more than 60 local Danfoss sales companies can ensure that the drive is correctly installed and commissioned. Once the equipment is commissioned the level of service the customer requires can be defined in an agreement with the customer according to his specific needs. At every step of the way, from development of new technologies and features, the mass production of highly customised products, to installation and service, Danfoss Drives has only the customer in mind.

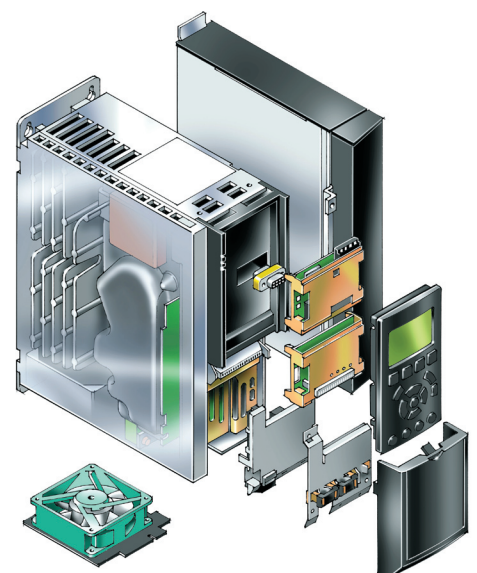



VLT® 2800 Series

An extremely compact series of drives prepared for side-by-side mounting and developed specifically for the low power market.

page 4



VLT® Decentral FCD 300

The VLT® Decentral FCD 300 is a complete frequency converter designed for decentral mounting.

page 18



VLT® AutomationDrive

The VLT® AutomationDrive represents a single drive concept to control the entire range of operations from standard to servo on any machine or production line.

page 6



VLT® Decentral Motor Starter DMS 300

The DMS 300 is the decentral motor starter with integrated soft-start functionality for decentral drive solutions where no variable speed is required.

page 20



VLT® 5000

The perfect match for an abundance of industrial applications.

page 8



VLT® Soft Starter MCD 100

The VLT® Soft Starter MCD 100 provides soft start features for low power applications 1.1 - 11 kW.

page 22



VLT® 5000 Flux

The VLT® 5000 Flux is an extension of the existing VLT® 5000 series. Full torque control also under acceleration as well as very accurate speed control even at low speed or standstill can now be obtained.

page 10



VLT® Compact Starter MCD 200

The MCD 200 is a compact and cost effective soft starter range for applications where direct-on-line starting is undesirable. MCD 200 is due to its size and functionality a good alternative to other reduced voltage starting methods such as start/delta starters.

page 24



VLT® HVAC Drive

The VLT® HVAC Drive integrates and communicates seamlessly with all HVAC devices, mastered by Building Management Systems or as stand-alone unit.

page 12



VLT® Soft Starter MCD 3000

The MCD 3000 is a total motor starter providing all the best in soft starter functionality. It offers high end functionality whether it is for starting, stopping or protection of motor or application.

page 26



VLT® 6000 HVAC

The VLT® 6000 HVAC is fully dedicated to the optimum operation of HVAC applications. It offers energy savings and user-friendliness, and all functions are built in.

page 14



VLT® Harmonic Filter AHF 005/010

Connecting the AHF 005/010 harmonic filter in front of a Danfoss frequency converter is an easy and effective way to reduce harmonic distortion.

page 28



VLT® 8000 AQUA

The VLT® 8000 AQUA is designed for the water and waste water market.

page 16



VLT® DriveMotor FCM 300

The VLT® FCM 300 Series is a very compact alternative to the traditional solution with a VLT® frequency converter and motor as separate units.

page 30

VLT® 2800 Series

The VLT® 2800 series are among the smallest multi purpose drives in the market. Designed for space saving side-by-side mounting. Choose to have it with built in Motor Coils, RFI filter, LC+1B filters e.g.

The VLT® 2800 was designed as an advanced and versatile drive, yet easy to operate. Quick menu Includes all parameters basically needed for commissioning the drive. Offers fast installation and service.



Flexible mounting

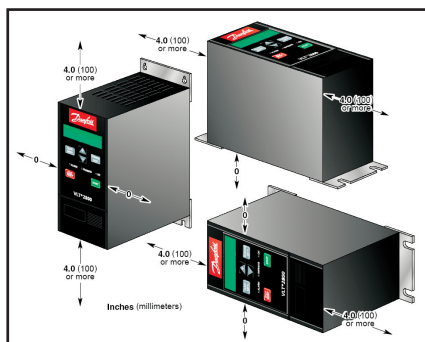

Product safety

- 100 % short-circuit proof
- 100 % earth fault protection
- Mains transient protection
- Switching on input
- Switching on output
- Galvanic isolation
- Designed according to EN50178

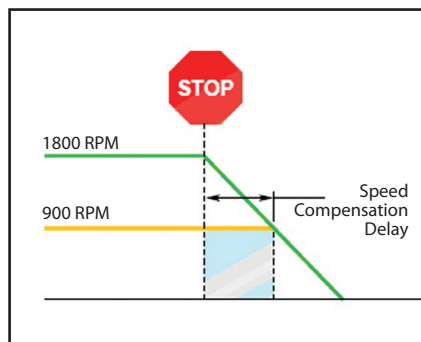

Precise stop

Conventional units rely on a periodic scan of the Digital Inputs, which initiates the Stop command. This can result in uneven delays while the Drive scans all the other parts of the program taking up to perhaps 10 ms. This is a disadvantage in typical packaging applications. For a conveyor operating at a speed of 1 meter/second, that gives a deviation of ± 10 mm. In the VLT® 2800, the Stop command is an Interrupt rather than part of the scan. The repeating precision is improved. The deviation is only ± 1 mm in the example used above.

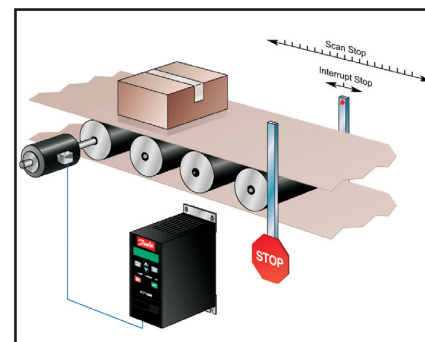

Counter Precise Stop

After the start signal is received, the VLT® 2800 operates until the user programmed number of pulses is seen at terminal 33. A Stop signal is generated and the normal stop ramp is used. The counter stop signal is then re-armed and ready again for a new start command. The pulse input is designed to handle 24 V push-pull pulses from an encoder with 1024 ppr. The maximum pulse rate is 67,600 Hz.

Specifications

Mains supply (L1, L2, L3):

Supply voltage VLT 2803-2815 220-240 V (N, L1).....	1 x 220/230/240 V ±10%
Supply voltage VLT 2803-2840 200-240V	3 x 200/208/220/230/240 V ±10%
Supply voltage VLT 2805-2882 380-480 V ...	3 x 380/400/415/440/480 V ±10%
Supply frequency	50/60 Hz ± 3 Hz
Max. imbalance on supply voltage	± 2.0% of rated supply voltage
True Power Factor (λ).....	0.90 nominal at rated load
Displacement Power Factor (cosφ)	near unity (> 0.98)
Number of connections at supply input L1, L2, L3	2 times/min.
Max. short-circuit value.....	100,000 A

Output data (U, V, W):

Output voltage.....	0 - 100% of supply voltage
Output frequency	0.2 - 132 Hz, 1 - 1000 Hz
Rated motor voltage, 200-240 V units	200/208/220/230/240 V
Rated motor voltage, 380-480 V units	380/400/415/440/460/480 V
Rated motor frequency	50/60 Hz
Switching on output.	Unlimited
Ramp times.....	0.02 - 3600 sec.

Torque characteristics:

Starting torque Constant torque).....	160% in 1 min.*
Starting torque (Variable torque)	160% in 1 min.*
Starting torque (parameter 119 High starting torque)	180% for 0.5 sec.*
Overload torque (Constant torque)	160%*
Overload torque (Variable torque)	160%*

*Percentage relates to frequency converter's nominal current.

Control card, digital inputs:

Number of programmable digital inputs	5
Terminal number	18, 19, 27, 29, 33
Voltage level.....	0 - 24 V DC (PNP positive logic)
Voltage level, logic '0'	< 5 V DC
Voltage level, logic '1'	> 10 V DC
Maximum voltage on input	28 V DC
Input resistance, Ri (terminals 18, 19, 27, 29)	approx. 4 kΩ
Input resistance, Ri (terminal 33)	approx. 2 kΩ

All digital inputs are galvanically isolated from the supply voltage (PELV) and other high-voltage terminals.

Control card, analog inputs:

Number of analog voltage inputs	1
Terminal number	53
Voltage level.....	0 - 10 V DC (scaleable)
Input resistance, Ri	approx. 10 kΩ
Max. voltage.....	20 V
Number of analog current inputs.....	1
Terminal number	60
Current level	0/4 - 20 mA (scaleable)
Input resistance, Ri	approx. 300 Ω
Max. current	30 mA
Resolution for analog inputs.....	10 bit
Accuracy of analog inputs.....	Max. error 1% of full scale
Scan interval.....	13.3 msec

The analog inputs are galvanically isolated from the supply voltage (PELV) and other high-voltage terminals.

Control card, pulse inputs:

Number of programmable pulse inputs	1
Terminal number	33
Max. frequency at terminal 33	67.6 kHz (Push-pull)
Max. frequency at terminal 33	5 kHz (open collector)
Min. frequency at terminal 33	4 Hz
Voltage level.	0 - 24 V DC (PNP positive logic)
Voltage level, logic '0'	< 5 V DC
Voltage level, logic '1'	> 10 V DC
Maximum voltage on input	28 V DC
Input resistance, Ri.....	approx. 2 kΩ
Scan interval.....	13.3 msec
Resolution	10 bit
Accuracy (100 Hz - 1 kHz) terminal 33	Max. error: 0.5% of full scale
Accuracy (1 kHz - 67.6 kHz) terminal 33	Max. error: 0.1% of full scale

The pulse input (terminal 33) is galvanically isolated from the supply voltage (PELV) and other high-voltage terminals.

Control card, digital/frequency output:

Number of programmable digital/pulse outputs	1 pcs.
Terminal number	46
Voltage level at digital/frequency output	0 - 24 V DC (O.C PNP)
Max. output current at digital/frequency output.....	25 mA.
Max. load at digital/frequency output.....	1 kΩ
Max. capacity at frequency output	10 nF
Minimum output frequency at frequency output	16 Hz
Maximum output frequency at frequency output.....	10 kHz
Accuracy on frequency output.....	Max. error: 0.2 % of full scale
Resolution on frequency output	10 bit

The digital output is galvanically isolated from the supply voltage (PELV) and other high-voltage terminals.

Control card, analog output:

Number of programmable analog outputs	1
Terminal number	42
Current range at analog output.....	0/4 - 20 mA
Max. load to common at analog output	500 Ω
Accuracy on analog output	Max. error: 1.5 % of full scale
Resolution on analog output	10 bit

The analog output is galvanically isolated from the supply voltage (PELV) and other high-voltage terminals.

Control card, 24 V DC output:

Terminal number	12
Max. load	130 mA

The 24 V DC supply is galvanically isolated from the supply voltage (PELV), but has the same potential as the analogue and digital inputs and outputs.

Control card, 10 V DC output:

Terminal number	50
Output voltage.....	10.5 V ±0.5 V
Max. load	15 mA

The 10 V DC supply is galvanically isolated from the supply voltage (PELV) and other high-voltage terminals.

Control card, RS 485 serial communication:

Terminal number.....	68 (TX+, RX+), 69 (TX-, RX-)
Terminal number 67	+ 5 V
Terminal number 70	Common for terminals 67, 68 and 69

Full galvanic isolation.

Relay outputs:

Number of programmable relay outputs.....	1
Terminal number, control card	1-3 (break), 1-2 (make)
Max. terminal load (AC) on 1-3, 1-2, control card	240 V AC, 2 A
Min. terminal load on 1-3, 1-2, control card.....	24 V DC 10 mA, 24 V AC 100 mA

The relay contact is separated from the rest of the circuit by strengthened isolation.

Cable lengths and cross sections:

Max. motor cable length, screened/armoured cable.....	40 m
Max. motor cable length, unscreened/unarmoured cable	75 m
Max. motor cable length, screened/armoured cable and motor coil ..	100 m
Max. motor cable length, unscreened/unarmoured cable and motor coil	200 m
Max. motor cable length, screened/armoured cable and RFI/1B filter.....	200 V, 100 m
Max. motor cable length, screened/armoured cable and RFI/1B or RFI 1B/LC filter.....	400 V, 25 m
Max. cross section to control wires, rigid wire	1.5 mm ² /16 AWG (2 x 0.75 mm ²)
Max. cross section to control cables, flexible cable	1 mm ² /18 AWG
Max. cross section to control cables, cable with enclosed core.....	0.5 mm ² /20 AWG

When complying with EN 55011 1A and EN 55011 1B the motor cable must in certain instances be reduced.

VLT® AutomationDrive

The VLT® AutomationDrive FC 300 is extremely configurable and runs any motor in any application and any machine for manufacturing. Specify your requirements and have your drives tailor-made within a couple of hours – for the cost of mass produced stockware.

Range:

0.25 – 37 kW (200 – 240 V)
 0.37 – 800 kW (380 – 500 V)
 37 – 1000 kW (600 V)

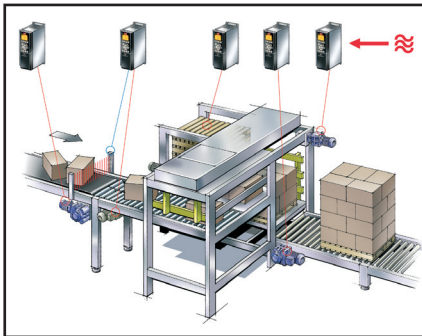

One-Drive concept

One drive concept covering the whole production or machine is a major benefit in commissioning, operating and maintaining the equipment. The make through modular design makes upgrade easy as well as adaptation of future features. On-board manuals make operation easy and the built in Smart Logic Control allows for basic programming covering most common PLC functions.

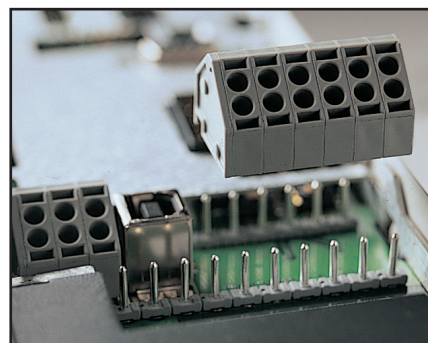

Plug and play

You don't have to disconnect wires in the cage clamps to disconnect the VLT® AutomationDrive. Just unplug the cage clamp instead.

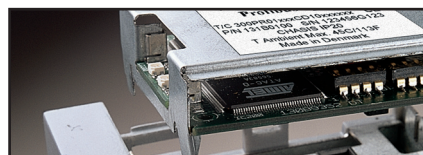

Pluggable options

The bus option, as shown above, ready to plug in underneath the front panel. It can be turned upside down if you prefer the cable to enter from the top.



USB pluggable

The VLT® AutomationDrive can be remotely commissioned and monitored through a USB pluggable cable or bus communication. Special software is available: Wizards, Data transfer tool, VLT® Set-up Software MCT 10.



Remote commissioning

Local control of the VLT® AutomationDrive is done by a local control panel. This is plugged in directly or connected through a cable. The control panel can also be connected directly to a PC for service or commissioning.

Specifications

Mains supply (L1, L2, L3):

Supply voltage	200-240 V ±10%
Supply voltage	FC 301: 380-480 V / FC 302: 380-500 V ±10%
Supply voltage	FC 302: 525-600 V ±10%
Supply frequency	50/60 Hz
Max. imbalance between mains phases	± 3.0 % of rated supply voltage
True Power Factor (λ).....	0.92 nominal at rated load
Displacement Power Factor (cosφ) near unity.....	(> 0.98)
Switching on input supply L1, L2, L3 (power-ups)	maximum 2 times/min.
Environment according to EN60664-1 overvoltage category 111/pollution degree 2.	

The unit is suitable for use on a circuit capable of delivering not more than 100,000 RMS symmetrical Amperes, 240/500/600 V maximum.

Digital inputs:

Programmable digital inputs	FC 301: 4 (5) / FC 302: 4 (6)
Terminal number	18, 19, 27 1), 291), 32, 33, 372)
Logic.....	PNP or NPN3)
Voltage level.....	0 - 24 V DC
Voltage level, logic '0' PNP.....	< 5 V DC
Voltage level, logic '1' PNP.....	> 10 V DC
Voltage level, logic '0' NPN3)	> 19 V DC
Voltage level, logic '1' NPN3)	< 14 V DC
Maximum voltage on input.....	28 V DC
Input resistance, Ri.....	approx. 4 kΩ

All digital inputs are galvanically isolated from the supply voltage (PELV) and other high-voltage terminals.

- 1) Terminals 27 and 29 can also be programmed as output.
- 2) Terminal 37 is only available in FC 302. It can only be used as "safe stop" input. Terminal 37 is suitable for category 3 installations according to EN 954-1 (safe stop according to category 0 EN 60204-1).
- 3) Exception: Terminal 37 is fixed PNP logic.

Analogue inputs:

Number of analogue inputs	2
Terminal number	53, 54
Modes	Voltage or current
Mode select	Switch S201 and switch S202
Voltage mode	Switch S201/switch S202 = OFF (U)
Voltage level.....	FC 301: 0 to + 10 / FC 302: -10 to +10 V (scaleable)
Input resistance, Ri.....	approx. 10 kΩ
Max. voltage	± 20 V
Current mode	Switch S201/switch S202 = ON (I)
Current level	0/4 to 20 mA (scaleable)
Input resistance, Ri.....	approx. 200 Ω
Max. current	30 mA
Resolution for analogue inputs	10 bit (+ sign)
Accuracy of analogue inputs.....	Max. error 0.5% of full scale
Bandwidth.....	FC 301: 20 Hz / FC 302: 100 Hz

The analogue inputs are galvanically isolated from the supply voltage (PELV) and other high-voltage terminals.

Pulse/encoder inputs:

Programmable pulse/encoder inputs	2/1
Terminal number pulse/encoder	29, 331) / 18, 32, 332)
Max. frequency at terminal 18, 29, 32, 33.....	110 kHz (Push-pull driven)
Max. frequency at terminal 18, 29, 32, 33	5 kHz (open collector)
Min. frequency at terminal 18, 29, 32, 33.....	4 Hz
Voltage level.....	see section on Digital input
Maximum voltage on input.....	28 V DC
Input resistance, Ri.....	approx. 4 kΩ
Pulse input accuracy (0.1 - 1 kHz)	Max. error: 0.1% of full scale
Encoder input accuracy (1 - 110 kHz)	Max. error: 0.05 % of full scale
32 (A), 33 (B) and 18 (Z)	

The pulse and encoder inputs (terminals 18, 29, 32, 33) are galvanically isolated from the supply voltage (PELV) and other high-voltage terminals.

- 1) Pulse inputs are 29 and 33
- 2) Encoder inputs: 18 = Z, 32 = A, and 33 = B

Digital output:

Programmable digital/pulse outputs	2
Terminal number	27, 29 1)
Voltage level at digital/frequency output	0 - 24 V
Max. load at frequency output	1 kΩ
Max. capacitive load at frequency output	10 nF
Minimum output frequency at frequency output	0 Hz
Maximum output frequency at frequency output	32 kHz
Accuracy of frequency output	Max. error: 0.1 % of full scale
Resolution of frequency outputs.....	12 bit

1) Terminal 27 and 29 can also be programmed as input.

The digital output is galvanically isolated from the supply voltage (PELV) and other high-voltage terminals.

Relay outputs:

Programmable relay outputs	FC 301: 1 / FC 302: 2
Terminal number,	
power card.....	1-3 (break), 1-2 (make), 4-6 (break), 4-5 (make)
Max. terminal load on 1-3 (break), 1-2 (make),	
4-6 (break) power card	240 V AC, 2 A
Max. terminal load (AC) on 4-5 (make) power card	400 V AC, 2 A
Min. terminal load on 1-3 (break), 1-2 (make),	
4-6 (break), 4-5 (make) power card	24 V DC 10 mA, 24 V AC 100 mA
Environment according to EN 60664-1 overvoltage category III/pollution degree 2.	

The relay contacts are galvanically isolated from the rest of the circuit by reinforced isolation (SELV).

VLT® 5000 Series

The VLT® Series 5000 available in the power range from 0.75 kW-500 kW suits all industrial applications.

Benefits:

- Saves space and energy – the compact size saves valuable space. The perfect speed matching to actual load reduces your energy costs.
- Easy to commission and use - If you know one drive you also know the others and a Quick Menu guides you easily through the little programming work left for you to make the drive perfect for the job in your plant.
- Multi-Setup – The drive has four independent setups.
- Enclosures IP20, IP54, IP00, Optional coating providing extra protection for aggressive environments. Compliance with international standards Built-in RFI filters available for the entire product range complying with EN55011, class 1A and 1B.

Complies also with IEC 61000-3-2 and 61000-3-4 as well as VDE 0160 as regards levels of harmonic suppression. That reduces the dimensions of cables substantially.

Product range:

200-690V: 0.75 kW - 500 kW

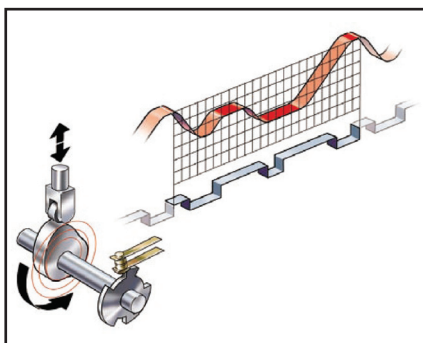

SyncPos

To complement the comprehensive functionality of VLT® frequency converters Danfoss Drives offers dedicated engineering solutions for your application. Based on the high flexibility of the Programmable SyncPos motion controller we tailor solutions to fit perfectly application requirements.

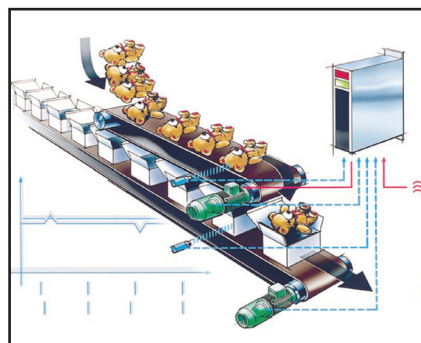

Marine approvals

- DNV – Det Norske Veritas
- GL – Germanischer Lloyd
- LRS – Lloyds Register of Shipping
- BV – Bureau Veritas
- ABS – American Bureau of Shipping
- RINA – Registro Italiano Navale

Fieldbus options

VLT® 5000 have dedicated fieldbus options for:

- Profibus DP V0
- Profibus DP V1
- DeviceNet
- Interbus
- Modbus+
- LonWorks

Specifications

Mains supply (L1, L2, L3):

Supply voltage 200-240 V units.....	3 x 200/208/220/230/240 V ±10%
Supply voltage 380-500 V units.....	3 x 380/400/415/440/460/500 V ±10%
Supply voltage 525-600 V units.....	3 x 525/550/575/600 V ±10%
Supply frequency:	
Max imbalance of supply voltage:	48-62 Hz +/- 1%
True Power factor (λ)	0.90 nominal at rated load
Displacement Power Factor (cos φ)	near unity (>0.98)
No. of switchings on supply input L1, L2, L3	approx. 1 time/min.

VLT output data (U, V, W):

Output voltage.....	0-100% of supply voltage
Output frequency.....	0 - 1000 Hz
Rated motor voltage, 200-240 V units	200/208/220/230/240 V
Rated motor voltage, 380-500 V units	380/400/415/440/460/480/500 V
Rated motor voltage, 525-600 V units	525/550/575 V
Rated motor frequency	Unlimited
Ramp times.....	0.05-3600 sec.

Control card, digital inputs:

Number of programmable digital inputs	8
Terminal nos.	16, 17, 18, 19, 27, 29, 32, 33
Voltage level.....	0-24 V DC (PNP positive logics)
Voltage level, logical '0'	< 5 V DC
Voltage level, logical '1'	>10 V DC
Maximum voltage on input	28 V DC
Input resistance, Ri.....	2 kΩ
Scanning time per input.	3 msec.

Reliable galvanic isolation: All digital inputs are galvanically isolated from the supply voltage (PELV). In addition, the digital inputs can be isolated from the other terminals on the control card by connecting an external 24 V DC supply and opening switch 4. VLT 5001-5250, 525-600 V do not meet PELV.

Control card, analogue inputs:

No. of programmable analogue voltage inputs/thermistor inputs	2
Terminal nos.	53, 54
Voltage level.....	0 ±10 V DC (scalable)
Input resistance, Ri.....	10 kΩ
No. of programmable analogue current inputs	1
Terminal no.	60
Current range.....	0/4 ±20 mA (scalable)
Input resistance, Ri.....	200 Ω
Resolution	10 bit + sign
Accuracy on input	Max. error 1% of full scale
Scanning time per input.....	3 msec.
Terminal no. ground.....	55

Reliable galvanic isolation: All analogue inputs are galvanically isolated from the supply voltage (PELV) * as well as other inputs and outputs. * VLT 5001-5250, 525-600 V do not meet PELV.

Control card, pulse/encoder input:

No. of programmable pulse/encoder inputs.....	4
Terminal nos.	17, 29, 32, 33
Max. frequency on terminal 17	5 kHz
Max. frequency on terminals 29, 32, 33.....	20 kHz (PNP open collector)
Max. frequency on terminals 29, 32, 33.....	65 kHz (Push-pull)
Voltage level.....	0-24 V DC (PNP positive logics)
Voltage level, logical '0'	< 5 V DC
Voltage level, logical '1'.....	>10 V DC
Maximum voltage on input.....	28 V DC
Input resistance, Ri.....	2 kΩ
Scanning time per input.....	3 msec.
Resolution	10 bit + sign
Accuracy (100-1 kHz), terminals 17, 29, 33.....	Max. error: 0.5% of full scale
Accuracy (1-5 kHz), terminal 17.....	Max. error: 0.1% of full scale
Accuracy (1-65 kHz), terminals 29, 33	Max. error: 0.1% of full scale

Reliable galvanic isolation: All pulse/encoder inputs are galvanically isolated from the supply voltage (PELV)*. In addition, pulse and encoder inputs can be isolated from the other terminals on the control card by connecting an external 24 V DC supply and opening switch 4. * VLT 5001-5250, 525-600 V do not meet PELV.

Control card, digital/pulse and analogue outputs:

No. of programmable digital and analogue outputs.	2
Terminal nos.	42, 45
Voltage level at digital/pulse output.....	0 - 24 V DC
Minimum load to ground (terminal 39) at digital/pulse output.....	600 Ω
Frequency ranges (digital output used as pulse output)	0-32 kHz
Current range at analogue output.....	0/4 - 20 mA
Maximum load to ground (terminal 39) at analogue output.....	500 Ω
Accuracy of analogue output	Max. error: 1.5% of full scale
Resolution on analogue output.....	8 bit

Reliable galvanic isolation: All digital and analogue outputs are galvanically isolated from the supply voltage (PELV)*, as well as other inputs and outputs. * VLT 5001-5250, 525-600 V do not meet PELV.

Control card, 24 V DC supply:

Terminal nos.	12, 13
Max. load (short-circuit protection).....	200 mA
Terminal nos. ground.....	20, 39

Reliable galvanic isolation: The 24 V DC supply is galvanically isolated from the supply voltage (PELV)*, but has the same potential as the analogue outputs. * VLT 5001-5250, 525-600 V do not meet PELV.

Control card, RS 485 serial communication:

Terminal nos.	68 (TX+, RX+), 69 (TX-, RX-)
--------------------	------------------------------

Reliable galvanic isolation: Full galvanic isolation.

Relay outputs:

No. of programmable relay outputs.	2
Terminal nos., control card.....	4-5 (make)
Max. terminal load (AC) on 4-5, control card.....	50 V AC, 1 A, 60 VA
Max. terminal load (DC) on 4-5, control card	75 V DC, 0.1 A, 30 W
Max. terminal load (DC) on 4-5, control card for UL/cUL applications	30 V AC, 1 A / 42.5 V DC, 1A
Terminal nos., power card	1-3 (break), 1-2 (make)
Max. terminal load (AC) on 1-3, 1-2, power card	240 V AC, 2 A, 60 VA
Max. terminal load on 1-3, 1-2, power card	50 V DC, 2 A
Min. terminal load on 1-3, 1-2, power card.	24 V DC 10 mA, 24 V AC 100 mA

Brake resistor terminals (only SB, EB, DE and PB units):

Terminal nos.	81, 82
--------------------	--------

External 24 Volt DC supply:

Terminal nos.	35, 36
Voltage range	24 V DC ±15% (max. 37 V DC for 10 sec.)
Max. voltage ripple	2 V DC
Power consumption	15 W - 50 W (50 W for start-up, 20 msec.)
Min. pre-fuse.....	6 Amp

Reliable galvanic isolation: Full galvanic isolation if the external 24 V DC supply is also of the PELV type.

Cable lengths, cross-sections and connectors:

Max. motor cable length, screened cable	150 m
Max. motor cable length, unscreened cable	300 m
Max. motor cable length, screened cable VLT 5011 380-500 V	100 m
Max. motor cable length, screened cable VLT 5011 525-600 V and VLT 5008, normal overload mode, 525-600 V	50 m
Max. brake cable length, screened cable.....	20 m
Max. loadsharing cable length, screened cable	25 m from frequency converter to DC bar.
Max. cable cross-section for 24 V external DC supply - VLT 5001-5027 200-240 V; VLT 5001-5102 380-500 V; VLT 5001-5062 525-600V	4 mm ² / 10 AWG
VLT 5032-5052 200-240 V; VLT 5122-5500 380-500 V; VLT 5075-5250 525-600 V.	2.5 mm ² / 12 AWG
Max. cross-section for control cables.....	1.5 mm ² / 16 AWG
Max. cross-section for serial communication.	1.5 mm ² / 16 AWG

If UL/cUL is to be complied with, cable with temperature class 60/75°C must be used (VLT 5001 - 5062 380 - 500 V, 525 - 600 V and VLT 5001 - 5027 200 - 240V). If UL/cUL is to be complied with, cable with temperature class 75°C must be used (VLT 5072 - 5500 380 - 500 V, VLT 5032 - 5052 200 - 240 V, VLT 5075 - 5250 525 - 600 V). Connectors are for use of both copper and aluminium cables, unless other is specified.

VLT® 5000 Flux

The VLT® 5000 Flux is an extension of the VLT® 5000 series.

Full torque control under acceleration as well as very accurate speed control even at low speed or standstill can be obtained.

Flux control is the future technology for high performance drives. It provides excellent dynamics and accuracy, suited for drives systems with and without feedback.

The VLT® 5000 Flux features automatic acquisition of motor equivalent circuit diagram and provides 100% control of flux and torque, taking the system inertia into account.

The VLT® 5000 Flux provides up to 160% torque from 0 to rated speed.

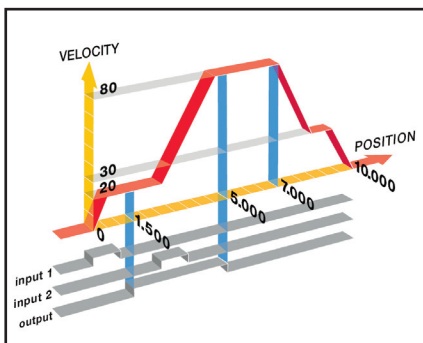

SyncPos

SyncPos makes VLT® 5000 Flux highly programmable and provides synchronising and positioning

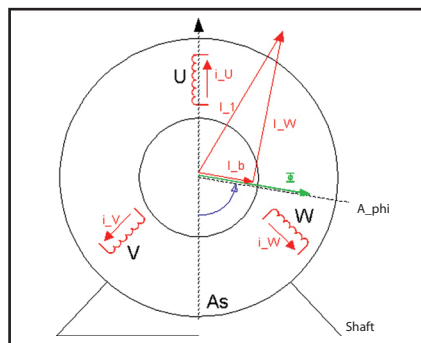

Flux principle

The flux principle provides high shaft performance (Torque control about 3 ms), excellent synchronizing also at very low speed. Speed accuracy with open loop: +/- 0.5 % (8 rpm) and with closed loop +/- 0.001 % (0.02 rpm). Flux control provides 180% acceleration torque (0.5 sec), 160% holding torque at 0 RPM for 60 sec (closed loop). The accuracy of torque control is: closed loop +/- 10%.



Plug-in terminals

Plug-in terminals for motor and control cables

Specifications

Mains supply (L1, L2, L3):

Supply voltage 200-240 V units.....	3 x 200/208/220/230/240 V ±10%
Supply voltage 380-500 V units.....	3 x 380/400/415/440/460/500 V ±10%
Supply frequency	48-62 Hz +/- 1%

Max imbalance of supply voltage:

VLT 5001-5011, 380-500 V and VLT 5001-5006, 200-240 V	±2.0% of rated supply voltage
VLT 5016-5062, 380-500 V and VLT 5008-5027, 200-240 V.....	±1.5% of rated supply voltage
VLT 5072-5500, 380-500 V and VLT 5032-5052, 200-240 V	±3.0% of rated supply voltage
True Power factor (λ)	0.90 nominal at rated load
Displacement Power Factor (cos φ).....	near unity (>0.98)
No. of switchings on supply input L1, L2, L3	approx. 1 time/min.

VLT® output data (U, V, W):

Output voltage.....	0-100% of supply voltage
Output frequency.....	0 - 132 Hz, 0 - 300 Hz
Rated motor voltage, 200-240 V units	200/208/220/230/240 V
Rated motor voltage, 380-500 V units	380/400/415/440/460/480/500 V
Rated motor frequency	50/60 Hz
Switching on output	Unlimited
Ramp times.....	0.01-3600 sec.

Control card, digital inputs:

Number of programmable digital inputs	8
Terminal nos.....	16, 17, 18, 19, 27, 29, 32, 33
Terminal number for none programmable digital input	37
Voltage level.....	0-24 V DC (PNP positive logics)
Voltage level, logical '0'	< 5 V DC
Voltage level, logical '1'	>10 V DC
Maximum voltage on input.....	28 V DC
Input resistance, Ri(terminal 16, 17, 18, 19, 27, 32, 33)	4 kΩ
Input resistance, Ri(terminal 29)	2 kΩ
Scanning time per input.....	3 msec.

Reliable galvanic isolation: All digital inputs are galvanically isolated from the supply voltage (PELV). In addition, the digital inputs can be isolated from the other terminals on the control card by connecting an external 24 V DC supply and opening switch 4.

Control card, analogue inputs:

No. of programmable analogue voltage inputs/thermistor inputs	2
Terminal nos.....	53, 54
Voltage level.....	0 - ±10 V DC (scalable)
Input resistance, Ri.....	10 kΩ
No. of programmable analogue current inputs	1
Terminal no.....	60
Current range	0/4 - ±20 mA (scalable)
Input resistance, Ri.....	200 Ω
Resolution	10 bit + sign
Accuracy on input.....	Max. error 1% of full scale
Scanning time per input.....	3 msec.
Terminal no. ground.....	55

Reliable galvanic isolation: All analogue inputs are galvanically isolated from the supply voltage (PELV) as well as other inputs and outputs.

Control card, pulse input:

No. of programmable pulse inputs.....	1
Terminal no.....	29
Max. frequency on terminal 29 (PNP open collector)	20 kHz
Max. frequency on terminal 29 (Push-pull).....	65 kHz
Voltage level.....	0-24 V DC (PNP positive logics)
Voltage level, logical '0'	< 5 V DC
Voltage level, logical '1'	>10 V DC
Maximum voltage on input.....	28 V DC
Input resistance, Ri.....	2 kΩ
Scanning time per input.....	3 msec.
Resolution	10 bit + sign
Accuracy (100-1 kHz), terminal 29.....	Max. error: 0.5% of full scale
Accuracy (1-65 kHz), terminal 29	Max. error: 0.1% of full scale

Reliable galvanic isolation: All pulse inputs are galvanically isolated from the supply voltage (PELV). In addition, pulse inputs can be isolated from the other terminals on the control card by connecting an external 24 V DC supply and opening switch 4.

Control card, encoder input:

No. of programmable encoder input connector	1
Input terminal nos	73, 74, 75, 76, 77, 78
Voltage level.....	RS 422/485
Maximum voltage on input.....	±7 V DC
Input resistance, Ri.....	140 Ω
Max. input frequency	250 kHz
Supply terminal nos	47, 49
Supply voltage	5 V
Max. supply current.....	250 mA

Reliable galvanic isolation: All encoder inputs are galvanically isolated from the supply voltage (PELV). In addition, encoder inputs can be isolated from the other terminals on the control card by connecting an external 24 V DC supply and opening switch 4.

Control card, digital/pulse outputs:

No. of programmable digital outputs.....	2
Terminal nos.....	6, 46
Voltage level at digital/pulse output	0 - 24 V DC
Minimum load to ground (terminal 39) at digital/pulse output	600 Ω
Frequency ranges (digital output used as pulse output)	100HZ-50 kHz
Refresh time	3 ms
Accuracy	±0.1% of full range

Galvanic isolation: All digital outputs are galvanically isolated from the supply voltage (PELV) as well as other inputs and outputs.

Control card, analogue outputs:

No. of programmable digital outputs.....	2
Terminal nos.....	42, 45
Current range at analogue output.....	0/4 - 20 mA
Maximum load to ground (terminal 39) at analogue output.....	500 Ω
Accuracy of analogue output	Max. error: 1% of full scale
Resolution on analogue output	8 bit

Galvanic isolation: All analogue outputs are galvanically isolated from the supply voltage (PELV) as well as other inputs and outputs.

Control card, 24 V DC supply:

Terminal nos.....	12, 13
Max. load (short-circuit protection).....	200 mA
Terminal nos. ground.....	20, 39

Reliable galvanic isolation: The 24 V DC supply is galvanically isolated from the supply voltage (PELV), but has the same potential as the analogue outputs.

Control card, RS 232 / RS 485 serial communication:

RS 232	RJ-11 connector
Terminal nos.....	68 (TX+, RX+), 69 (TX-, RX-)

Full galvanic isolation.

Relay outputs:

No. of programmable relay outputs.....	2
Terminal nos., control card.....	4-5 (make)
Max. terminal load (AC) on 4-5, control card.....	50 V AC, 1 A, 60 VA
Max. terminal load (DC-1, IEC847) on 4-5, control card.....	75 V DC, 0.1 A, 30 W
Max. terminal load (DC-1, IEC947) on 4-5, control card for UL/cUL applications.....	30 V AC, 1 A / 42.5 V DC, 1A
Terminal nos., power card.....	1-3 (break), 1-2 (make)
Max. terminal load (AC) on 1-3, 1-2, power card	40 V AC, 2 A, 60 VA
Max. terminal load (DC-1, IEC947) on 1-3, 1-2, power card	50 V DC, 2 A
Min. terminal load on 1-3, 1-2, power card..	24 V DC 10 mA, 24 V AC 100 mA

Brake resistor terminals (only SB, EB, DE and PB units):

Terminal nos.	81, 82
--------------------	--------

External 24 Volt DC supply:

Terminal nos.....	35, 36
Voltage range	24 V DC ±15% (max. 37 V DC for 10 sec.)
Max. voltage ripple	2 V DC
Power consumption	15 W - 50 W (50 W for start-up, 20 msec.)
Min. pre-fuse	6 Amp

Reliable galvanic isolation: Full galvanic isolation if the external 24 V DC supply is also of the PELV type.

VLT® HVAC Drive

The VLT® HVAC Drive integrates and communicates seamlessly with all HVAC devices, mastered by Building Management Systems or as stand-alone unit. HVAC-specific features makes it economical, flexible and user-friendly and makes HVAC operation child's play.

Lowest cost of ownership

The modular concept allows you to pay only for features you need and to customise your solutions and minimise system costs. The HVAC Drive is maintenance free, compact and easily mounted inside a HVAC unit or panel. Advanced, adaptable drive technology in the HVAC Drive generates significant energy savings while ensuring perfect comfort levels.

- Built-in real time clock
- Smart Logic Controller
- 4 auto-tuned PID controllers
- Easy to use menu structure
- Integrates with all BMS protocols
- Graphical display
- Optional mains disconnect switch
- Automatic Energy Optimisation
- Energy monitoring

Power range:

200-240V: 1.1 kW – 45 kW
380-480V: 1.1 kW – 400 kW
525-600V: 1.1 kW – 400 kW



Dedicated pump features

- Pump Cascade Controller
- Sleep Mode
- Sensorless Pressure/Flow Control
- Dry Pump Protection
- Continuous pumping, also at overload
- End of Curve monitoring
- Flow compensation at setpoint

Dedicated fan features

- Broken belt detection
- Resonance Monitoring
- Fire Override mode
- Stairwell Pressurizations
- Automated skip frequencies
- Supply and return flow balancing
- Very fast flying start
- Conversion of feedback signal

Dedicated compressor features

- Capacity Modulation
- Constant torque above 20 Hz
- Cascade Controller
- 160% break away torque
- Set point in temperature or pressure conversion
- Reduced number of starts and stops

Application options:

A wide range of integrated HVAC options can be fitted in the drive:

General purpose I/O option:

3 digital inputs, 2 digital outputs, 1 analog current output, 2 analog voltage inputs

Relay option:

3 relay outputs

Analogue I/O option:

3 Pt1000 / Ni1000 inputs, 3 analog voltage outputs

External 24 VDC supply option :

24 VDC external supply can be connected to supply control- and option cards

Brake chopper option:

Built in resistor for removing energy in case of high dynamics or high inertia loads

Ambient temperature rating:

50°C

Power options

Danfoss Drives offers a wide range of external power options for use together with our FC102 drive in critical networks or applications:

- **Advanced harmonic filters:** For critical demands on harmonic distortion
- **dv/dt filters:** For special demands on motor isolation protection
- **Sine filters** (LC filters): For noiseless motor

HVAC PC software

- **MCT 10**
 - ideal for commissioning and servicing the drive
- **VLT HVAC Planet**
 - an interactive design guide including application examples.
- **VLT Energy Box**
 - comprehensive energy analysis tool, shows the drive pay-back time
- **MCT 31**
 - harmonics calculations tool

Specifications

Mains supply (L1, L2, L3):

Supply voltage:200-240 V ±10%
Supply voltage:380-500 V ±10%
Supply voltage:525-600 V ±10%
Supply frequency 50/60 Hz
Displacement Power Factor (cos φ) near unity (> 0.98)
Switching on input supply L1, L2, L3 1-2 times/min.

Output data (U, V, W):

Output voltage..... 0-100% of supply voltage
Switching on output Unlimited
Ramp times 1 - 3600 sec.
Closed loop0-132 Hz

Digital inputs:

Programmable digital inputs, FC 102:6*
LogicPNP or NPN
Voltage level0 - 24 VDC
* 2 can be used as digital outs

Analog inputs:

Analog inputs2
Modes Voltage or current
Voltage level:-10 to +10 V (scaleable)
Current level0/4 to 20 mA (scaleable)

Pulse inputs:

Programmable pulse inputs2
Voltage level 0 - 24 VDC (PNP positive logic)
Pulse input accuracy (0.1 - 110 kHz)
Utilize some of the digital inputs

Analog output:

Programmable analog outputs1
Current range at analog output 0/4 - 20 mA

Relay outputs:

Programmable relay outputs:2
(240 VAC, 2 A and 400 VAC, 2 A)

Fieldbus communication:

Standard built in:	Optional:
• FC Protocol	• LonWorks
• N2 Metasys	• BACnet
• FLN Apogee	• DeviceNet
• Modbus RTU	• Profibus

VLT® 6000 HVAC

The Danfoss VLT® 6000 HVAC, dedicated to HVAC applications, provides unsurpassed performance, energy savings and improved control of HVAC systems – including interfacing with building management systems. Precise control of temperature, pressure and flow in HVAC applications results in the best environmental performance for building owners and operators.

Range: 1.1-400 kw (380-460V)

Fan benefits:

- Bypass. The fan motor steps over speeds which cause mechanical vibration.
- Sleep Mode. The drive automatically stops cooling when temperature is at a low level for a pre-determined time.
- De-Icing. Reverses the fan to remove ice accumulation from intake louvers. The VLT® drive can reverse airflow direction for timed durations to prevent ice accumulation for both the intake louvers and exhaust fan blades.
- Motor Preheat. To extend the life of a motor in a damp environment, a small amount of current can be trickled into the motor to protect it from condensation and effects of a cold start.



Easy to commission and use

If you know one drive you also know the others. A Quick Menu guides you easily through the little programming work left for you to make the drive perfect for the job in your plant.

The VLT® 6000 HVAC provides full control of the motor directly from the user interface. "HAND START" enables start and control of motor speed, "OFF" turns off the motor and "AUTO START" shifts control to digital inputs and/or serial communication.

Performance and energy saving

Using frequency converters in HVAC systems is mostly a question of ultimate energy savings. VLT® 6000 HVAC is designed with HVAC systems in mind.

Consequently it contains a series of HVAC dedicated functionalities.

- Automatic Energy Optimizer, makes it possible to save up to an additional 5-10% on the energy bill. This function optimises the magnetising current to the motor according to the specific load.
- The sleep mode function. If a pump or fan is running at low speed and not really contributing to the controlled parameter, e.g. temperature, pressure etc. it is turned off automatically. When the system again calls for energy, the drive starts up the motor again.
- Frequency bypass. The drive can be programmed to bypass up to 4 frequencies avoiding frequencies that provoke resonance between the pump/fan and the cabinet. that creates noise and eventually cause damage to the components.
- Sensorless Pump Control. For pump OEM's Danfoss Drives offers a new unique feature called Sensorless Pump Control. This feature enables the drive to control pressure in a water system without using a pressure transmitter. This saves costs for the pump manufacturer in commissioning and direct costs in transmitter, installation etc.

Specifications

Mains supply (L1, L2, L3):

Supply voltage 200 - 690 V units	3 x 200 - 690 V, $\pm 10\%$
Supply frequency	48-62 Hz $\pm 1\%$
Max. imbalance of supply voltage	$\pm 3\%$
VLT 6002-6011, 380-460 V and 525-600 V and VLT 6002-6005, 200-240 V	$\pm 2.0\%$ of rated supply voltage
VLT 6016-6072, 380-460 V and 525-600 V and VLT 6006-6032, 200-240 V	$\pm 1.5\%$ of rated supply voltage
VLT 6102-6550, 380-460 V and VLT 6042-6062, 200-240 V	$\pm 3.0\%$ of rated supply voltage
VLT 6100-6275, 525-600 V	$\pm 3\%$ of rated supply voltage
True Power factor (λ)	0.90 nominal at rated load
Displacement Power Factor ($\cos.\phi$)	near unity (>0.98)
No. of switches on supply input L1, L2, L3	approx. 1 time/2 min.
Max. short-circuit current	100.000 A

Output data (U, V, W):

Output voltage	0-100% of supply voltage
Output frequency 6002-6032, 200-240 V	0-120 Hz, 0-1000 Hz
Output frequency	0 - 1000 Hz
Rated motor voltage, 200-240 V units	200/208/220/230/240 V
Rated motor voltage, 380-460 V units	380/400/415/440/460 V
Rated motor voltage, 525-600 V units	525/550/575 V
Rated motor frequency	50/60 Hz
Switching on output	Unlimited
Ramp times	1 - 3600 sec.

Torque characteristics:

Starting torque	130% for 1 min.
Starting torque (parameter 110 High break-away torque)	160% for 0.5 sec.
Acceleration torque	100%
Overload torque	110%

Control card, digital inputs:

Number of programmable digital inputs	8
Terminal nos.	16, 17, 18, 19, 27, 29, 32, 33
Voltage level	0-24 V DC (PNP positive logics)
Voltage level, logical '0'	< 5 V DC
Voltage level, logical '1'	> 10 V DC
Maximum voltage on input	28 V DC
Input resistance, Ri	2 k
Scanning time per input	3 msec.

Reliable galvanic isolation: All digital inputs are galvanically isolated from the supply voltage (PELV). In addition, the digital inputs can be isolated from the other terminals on the control card by connecting an external 24 V DC supply and opening switch 4.

Control card, analogue inputs

No. of programmable analogue voltage inputs/thermistor inputs	2
Terminal nos.	53, 54
Voltage level	0 - 10 V DC (scalable)
Input resistance, Ri	approx. 10 k
No. of programmable analogue current inputs	1
Terminal no ground	55
Current range	0/4 - 20 mA (scalable)
Input resistance, Ri	200
Resolution	10 bit + sign
Accuracy on input	Max. error 1% of full scale
Scanning time per input	3 msec.

Reliable galvanic isolation: All analogue inputs are galvanically isolated from the supply voltage (PELV) and other high-voltage terminals.

Control card, pulse input:

No. of programmable pulse inputs	3
Terminal nos.	17, 29, 33
Max. frequency on terminal 17	5 kHz
Max. frequency on terminals 29, 33	20 kHz (PNP open collector)
Max. frequency on terminals 29, 33	65 kHz (Push-pull)
Voltage level	0-24 V DC (PNP positive logics)
Voltage level, logical '0'	< 5 V DC
Voltage level, logical '1'	> 10 V DC
Maximum voltage on input	28 V DC
Input resistance, Ri	2 k
Scanning time per input	3 msec.
Resolution	10 bit + sign

Accuracy (100-1 kHz), terminals 17, 29, 33	Max. error: 0.5% of full scale
Accuracy (1-5 kHz), terminal 17	Max. error: 0.1% of full scale
Accuracy (1-65 kHz), terminals 29, 33	Max. error: 0.1% of full scale

Reliable galvanic isolation: All pulse inputs are galvanically isolated from the supply voltage (PELV). In addition, pulse inputs can be isolated from the other terminals on the control card by connecting an external 24 V DC supply and opening switch 4.

Control card, digital/pulse and analogue outputs:

No. of programmable digital and analogue outputs	2
Terminal nos.	42, 45
Voltage level at digital/pulse output	0 - 24 V DC
Minimum load to ground (terminal 39) at digital/pulse output	600
Frequency ranges (digital output used as pulse output)	0-32 kHz
Current range at analogue output	0/4 - 20 mA
Maximum load to ground (terminal 39) at analogue output	500
Accuracy of analogue output	Max. error: 1.5% of full scale
Resolution on analogue output	8 bit

Reliable galvanic isolation: All digital and analogue outputs are galvanically isolated from the supply voltage (PELV) and other high-voltage terminals.

Control card, 24 V DC supply:

Terminal nos.	12, 13
Max. load	200 mA
Terminal nos. ground	20, 39

Reliable galvanic isolation: The 24 V DC supply is galvanically isolated from the supply voltage (PELV), but has the same potential as the analogue outputs.

Control card, RS 485 serial communication:

Terminal nos.	68 (TX+, RX+), 69 (TX-, RX-)
---------------	------------------------------

Reliable galvanic isolation: Full galvanic isolation (PELV).

Relay outputs:

No. of programmable relay outputs	2
Terminal nos., control card	4-5 (make)
Max. terminal load (AC) on 4-5, control card	50 V AC, 1 A, 60 VA
Max. terminal load (DC-1 (IEC 947)) on 4-5, control card	75 V DC, 1 A, 30 W
Max. terminal load (DC-1) on 4-5, control card for UL/cUL applications	30V AC, 1 A /42.5 V DC, 1A
Terminal nos., power card and relay card	1-3 (break), 1-2 (make)
Max. terminal load (AC) on 1-3, 1-2 power card	240 V AC, 2 A, 60 VA
Max. terminal load DC-1 (IEC 947) on 1-3, 1-2, power card and relay card	50 V DC, 2 A
Min. terminal load on 1-3, 1-2, power card	24 V DC, 10 mA, 24 V AC, 100 mA

External 24 Volt DC supply (only with VLT 6152-6550, 380-460 V):

Terminal nos.	35, 36
Voltage range	24 V DC $\pm 15\%$ (max. 37 V DC for 10 sec.)
Max. voltage ripple	2 V DC
Power consumption	15 W - 50 W (50 W for start-up, 20 msec.)
Min. pre-fuse	6 Amp

Reliable galvanic isolation: Full galvanic isolation if the external 24 V DC supply is also of the PELV type.

Cable lengths and cross-sections:

Max. motor cable length, screened cable	150 m
Max. motor cable length, unscreened cable	300 m
Max. motor cable length, screened cable VLT 6011 380-460 V	100 m
Max. motor cable length, screened cable VLT 6011 525-600 V	50 m
Max. DC-bus cable length, screened cable	25 m from frequency converter to DC bar.
Max. cross-section for 24 V external DC supply	2.5 mm ² /12 AWG
Max. cross-section for control cables	1.5 mm ² /16 AWG
Max. cross-section for serial communication	1.5 mm ² /16 AWG

If UL/cUL is to be complied with, cable with temperature class 60/75°C must be used (VLT 6002 - 6072 380 - 460 V, 525-600 V and VLT 6002 - 6032 200 - 240 V).

If UL/cUL is to be complied with, cable with temperature class 75°C must be used (VLT 6042 - 6062 200 - 240 V, VLT 6102 - 6550 380 - 460 V, VLT 6100 - 6275 525 - 600 V). Connectors are for use of both copper and aluminium cables, unless other is specified.

VLT® 8000 AQUA

The Danfoss VLT® 8000 AQUA is a dedicated drive for Water and Waste water applications.

It has all the good traditional features a Danfoss drive is known for – but on top of that it offers a little bit extra. This drive is built for both constant torque and variable torque in applications including water, sludge and dosing pumps, aeration blowers, pumps, irrigation equipment, water desalination machines etc. For these applications specific software features have been developed to ensure optimum control and energy savings.

Range:

4-400 kW 380-480V



Easy to commission and use

If you know one drive you also know the others. A Quick Menu guides you easily through the little programming work left for you to make the drive perfect for the job in your plant. The VLT® 8000 AQUA provides full control of the motor directly from the user interface. "HAND START" enables start and control of motor speed, "OFF" turns off the motor and "AUTO START" shifts control to digital inputs and/or serial communication.

Performance and energy saving

Water and Waste water applications are typically characterised by machines with high power consumption. So in these applications there is also typically a great energy saving

potential. With large power machines a good and precise control of e.g. water pumps is very important to avoid water hammering.

These aspects have been taken into account when designing the VLT® 8000 AQUA. Among the useful dedicated solutions included are:

- VLT® 8000 AQUA includes both Variable and Constant Torque operation.
- The unique Danfoss Drives AEO function (Automatic Energy Optimizer), makes it possible to save up to an additional 5-10% on the energy bill.

This function optimises the magnetising current to the motor according to

the specific load. Consequently valuable energy is saved and not wasted on heating up the air around the motor.

- The VLT® 8000 AQUA provides an initial ramp for fast ramping of pumps and blowers. This eliminates damage and reduces wear of the devices.
- With the Fill Mode feature, it is possible to avoid water hammering when starting up systems, i.e. irrigation, water supply etc. This is a closed loop pressure control functionality, which ensures that ramping up the speed to maximum reference does not occur before the pipes are filled up.

Specifications

Mains supply (L1, L2, L3):

Supply voltage 200-240 V units.....	3 x 200/208/220/230/240 V ±10%
Supply voltage 380-480 V units.....	3 x 380/400/415/440/460/480 V ±10%
Supply voltage 525-600 V units.....	3 x 525/550/575/600 V ±10%
Supply frequency	50/60 Hz +/- 1%
Max. imbalance of supply voltage: . VLT 8006 - 8011 AQUA / 380 - 480 V and VLT 8002 - 8011 AQUA / 525 - 600V	±2.0% of rated supply voltage
VLT 8016 - 8072 AQUA / 525 - 600 V, 380 - 480 V,	
VLT 8006 - 8032 AQUA / 200 - 240 V	±1.5% of rated supply voltage
VLT 8100 - 8300 AQUA / 525 - 600 V, VLT 8102 - 8600 AQUA / 380 - 480 V and VLT 8042 - 8062 AQUA / 200 - 240 V	±3.0% of rated supply voltage
Displacement factor / cos. φ.....	near unity (> 0.98)
True Power Factor (λ).....	nominal 0.90 at rated load
Input Mains (L1, L2, L3) Allowable On-OFF	
Switching Sequences approx.....	1 time/2 min.
Max. short-circuit current	100 kA

VLT® output data (U, V, W):

Output voltage.....	0-100% of supply voltage
Output frequency:	0 - 1000 Hz
Rated motor voltage, 200-240 V units	200/208/220/230/240 V
Rated motor voltage, 380-480 V units	380/400/415/440/460/480 V
Rated motor voltage, 525-600 V units	525/550/575 V
Rated motor frequency	50/60 Hz
Switching on output	Unlimited
Ramp times.....	1- 3600 sec.

Control card, digital inputs:

Number of programmable digital inputs.....	8
Voltage level.....	0-24 V DC (PNP positive logics)
Voltage level, logical "0"	< 5 V DC
Voltage level, logical "1"	> 10 V DC
Maximum voltage on input.....	28 V DC
Input resistance, Ri.....	approx. 2 kΩ
Scanning time per input.....	3 msec.

Reliable galvanic isolation: All digital inputs are galvanically isolated from the supply voltage (PELV). In addition, the digital inputs can be isolated from the other terminals on the control card by connecting an external 24 V DC supply and opening switch 4.

Control card, analogue inputs:

No. of programmable analogue voltage inputs/thermistor inputs	2
Voltage level.....	0 - 10 V DC (scalable)
Input resistance, Ri.....	approx. 10 Ω
No. of programmable analogue current inputs	1
Terminal no. earth	55
Current range.....	0/4 - 20 mA (scalable)
Input resistance, Ri.....	approx. 200 Ω
Resolution	10 bit + sign
Accuracy on input	Max. error 1% of full scale
Scanning time per input.....	3 msec.

Reliable galvanic isolation: All analogue inputs are galvanically isolated from the supply voltage (PELV) and other high-voltage terminals.

Control card, pulse input:

No. of programmable pulse inputs	3
Max. frequency on terminal 17	5 kHz
Max. frequency on terminals 29, 33.....	20 kHz (PNP open collector)
Max. frequency on terminals 29, 33.....	65 kHz (Push-pull)
Voltage level.....	0-24 V DC (PNP positive logics)
Voltage level, logic "0"	< 5 V DC
Voltage level, logic "1"	> 10 V DC
Maximum voltage on input.....	28 V DC
Input resistance, Ri.....	approx. 2 kΩ
Scanning time per input.....	3 msec.
Resolution	10 bit + sign
Accuracy (100-1 kHz), terminals 17, 29, 33.....	Max. error: 0.5% of full scale
Accuracy (1-5 kHz), terminal 17.....	Max. error: 0.1% of full scale
Accuracy (1-65 kHz), terminals 29, 33	Max. error: 0.1% of full scale

Reliable galvanic isolation: All pulse inputs are galvanically isolated from the supply voltage (PELV). In addition, pulse inputs can be isolated from the other terminals on the control card by connecting an external 24 V DC supply and opening switch 4.

Torque characteristics:

Starting torque.....	110% for 1 min.
Starting torque (parameter 110 High break-away torque)	
Max. torque.....	130% for 0.5 s.
Acceleration torque.....	100%
Overload torque	110%

Control card, digital/pulse and analogue outputs:

No. of programmable digital and analogue outputs	2
Terminal nos.....	42, 45
Voltage level at digital/pulse output.....	0 - 24 V DC
Minimum load to frame (terminal 39) at digital/pulse output	600 Ω
Frequency ranges (digital output used as pulse output)	0-32 kHz
Current range at analogue output.....	0/4 - 20 mA
Maximum load to frame (terminal 39) at analog output	500 Ω
Accuracy of analogue output	Max. error: 1.5% of full scale
Resolution on analogue output.....	8 bit

Reliable galvanic isolation: All digital and analog outputs are galvanically isolated from the supply voltage (PELV) and other high-voltage terminals.

External 24 Volt DC supply:

(only available with VLT 8152-8600, 380-480 V)	
Voltage range	24 V DC ±15% (max. 37 V DC for 10 sec.)
Max. voltage ripple	2 V DC
Power consumption	15 W - 50 W (50Wfor start-up, 20 msec.)
Min. pre-fuse.....	6 Amp

Reliable galvanic isolation: Full galvanic isolation if the external 24 V DC supply is also of the PELV type.

Control card, RS 485 serial communication :

Terminal nos.....	68 (TX+, RX+), 69 (TX-, RX-)
-------------------	------------------------------

Reliable galvanic isolation: Full galvanic isolation (PELV).

Relay outputs:

No. of programmable relay outputs	2
Max. terminal load (AC) on 4-5, control card.....	50 V AC, 1 A, 60 VA
Max. terminal load (DC-1 (IEC 947)) on 4-5, control card... ..	75 V DC, 1 A, 30 W
Max. terminal load (DC-1) on 4-5, control card for UL/cUL applications	30 V AC, 1 A / 42.5 V DC, 1A
Terminal nos., power card and relay card.....	1-3 (break), 1-2 (make)
Max. terminal load (AC) on 1-3, 1-2 power card.....	240 V AC, 2 A, 60 VA
Max. terminal load DC-1 (IEC 947) on 1-3, 1-2, power card and relay card.....	50 V DC, 2 A
Min. terminal load on 1-3, 1-2, power card..	24 V DC, 10 mA, 24 V AC, 100 mA

Control card, 24 V DC supply:

Terminal nos.....	12, 13
Max. load.....	200 mA
Terminal nos. earth	20, 39

Reliable galvanic isolation: The 24 V DC supply is galvanically isolated from the supply voltage (PELV), but has the same potential as the analogue outputs.

Cable lengths and cross-sections:

Max. motor cable length, screened cable	150m/500 ft
Max. motor cable length, unscreened cable	300m/1000 ft
Max. motor cable length, screened cable VLT 8011 380-480 V ...	100m/330 ft
Max. motor cable length, screened cable VLT 8011 525-600 V	50m/164 ft
Max. DC-bus cable length, screened cable	25m/82 ft from frequency converter to DC bar.
Max. cross-section for 24 V external DC supply	2.5 mm ² /12 AWG
Max. cross-section for control cables	1.5 mm ² /16 AWG
Max. cross-section for serial communication	1.5 mm ² /16 AWG

Connectors are for use of both copper and aluminium cables, unless other is specified.

Control characteristics:

Frequency range.....	0 - 120 Hz
Resolution on output frequency	±0.003 Hz
System response time.....	3 msec.
Speed, control range (open loop).....	1:100 of synchro. speed
Speed, accuracy (open loop) . < 1500 rpm:	max. error ± 7.5 rpm
> 1500 rpm:	max. error of 0.5% of actual speed
Process, accuracy (closed loop). < 1500 rpm:	max.error ± 1.5 rpm
> 1500 rpm:	max. error of 0.1% of actual speed

All control characteristics are based on a 4-pole asynchronous motor.

VLT® Decentral FCD 300

The VLT® FCD 300 is a complete frequency converter designed for decentral mounting. The FCD can be mounted on the wall close to the motor, or directly on the motor. The FCD 300 comes in a high enclosure class, IP66, to withstand normal cleaning methods. The design offers a smooth cleaning friendly surface without any difficult to clean spots. The FCD 300 comes in a robust painted surface.

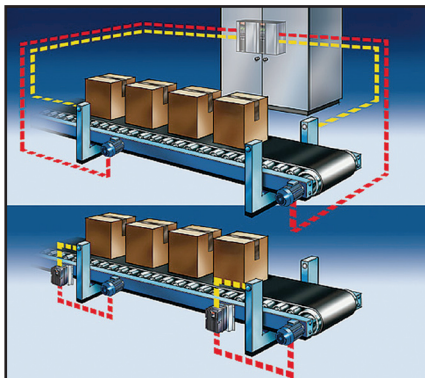

The decentral design reduces the need for central control panels and space-consuming motor control cabinets are eliminated. Reduced need for wiring long screened motor cables.

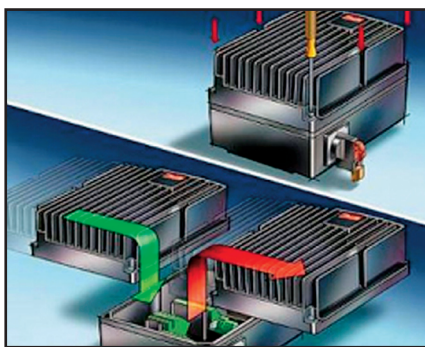

Plug-and-drive

All the advanced and reliable electronics needed to ensure your motors act smoothly, responsively and economically at each command are hidden inside the box lid and plug into connectors when mounted onto the bottom section. The bottom section contains maintenance-free Cage Clamp connectors and looping facilities for power and fieldbus cables well protected against dust, hosing and cleaning agents. Once installed, commissioning and upgrading can be performed in no time by plugging in another control lid.



Hygienic

Protected in small, tight, robust, dirt repelling enclosures the FCD 300 meets conditions found in the food and beverage industry, where frequent wash downs are required.

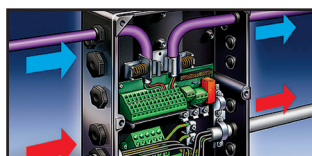

Flexible installation

The FCD 300 series facilitates internal power line looping. Terminals for 4 mm² power cables inside the enclosure allows connection of up to 10+ units.

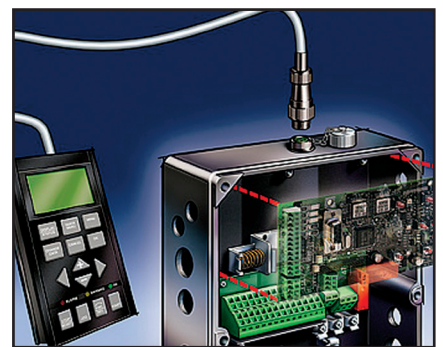

Control

Decentral drives are complete variable speed drives to be set up and controlled through a remote control panel or fieldbus communication and Danfoss' dedicated MCT 10 set-up software.

Specifications

Supply voltage FCD 305-335 380-480 V

.....	3 x 380/400/415/440/480 V ±10%
Supply frequency	50/60 Hz
Max. imbalance on supply voltage	± 2.0% of rated supply voltage
Power factor (400 V) / cos. 1	0.90 / 1.0 at rated load
Number of connections at supply input L1, L2, L3	2 times/min.

Torque characteristics:

Starting torque (Constant torque)	maximum 160% for 1 min.*
Starting torque.....	maximum 180% up to 0.5 sec.*
Overload current (Constant torque).....	maximum 160% for 1 min.*

*Percentage relates to FC 300's nominal current.

Control card, digital inputs:

Number of programmable digital inputs	5
Terminal number	18, 19, 27, 29, 33
Voltage level.....	0 - 24 V DC (PNP positive logic)
Voltage level, logic '0'	< 5 V DC
Voltage level, logic '1'	> 10 V DC
Maximum voltage on input.....	28 V DC
Input resistance, Ri (terminals 18, 19, 27)	approx. 4 kΩ
Input resistance, Ri (terminal 29, 33)	approx. 2 kΩ

All digital inputs are galvanically isolated from the supply voltage (PELV) and other high-voltage terminals, and can be functionally separated from other control terminals by opening switch S100.

Control card, analogue inputs:

Number of analogue voltage inputs	1 pcs.
Terminal number	53
Voltage level.....	± 0 - 10 V DC (scaleable)
Input resistance, Ri.....	approx. 10 kΩ
Max. voltage.....	20 V
Number of analogue current inputs	1 pcs.
Terminal number	60
Current level.....	0/4 - 20 mA (scaleable)
Input resistance, Ri.....	approx. 300 Ω
Max. current	30 mA
Resolution for analogue inputs.....	10 bit
Accuracy of analogue inputs.....	Max. error 1% of full scale
Scan interval.....	13.3 msec

The analogue inputs are galvanically isolated from the supply voltage (PELV) and other high-voltage terminals.

Control card, pulse inputs:

Number of programmable pulse inputs	2
Terminal number	29, 33
Max. frequency at terminal 29/33	110 kHz (Push-pull)
Max. frequency at terminal 29/33	5 kHz (open collector)
Min. frequency at terminal 33.....	4 Hz
Min. frequency at terminal 29.....	30 Hz
Voltage level	0 - 24 V DC (PNP positive logic)
Voltage level, logic '0'	< 5 V DC
Voltage level, logic '1'	> 10 V DC
Maximum voltage on input	28 V DC
Input resistance, Ri.....	approx. 2 kΩ
Scan interval.....	13.3 msec
Resolution	10 bit
Accuracy (100 Hz - 1 kHz) terminal 33	Max. error: 0.5% of full scale
Accuracy (1 kHz - 67.6 kHz) terminal 33	Max. error: 0.1% of full scale

The pulse input is galvanically isolated from the supply voltage (PELV) and other high-voltage terminals.

Control card, digital/frequency output:

Number of programmable digital/pulse outputs	1 pcs.
Terminal number	46
Voltage level at digital/frequency output	0 - 24 V DC (O.C PNP)
Max. output current at digital/frequency output	25 mA.
Max. load at digital/frequency output.....	1 kΩ
Max. capacity at frequency output.....	10 nF
Minimum output frequency at frequency output	16 Hz
Maximum output frequency at frequency output	10 kHz
Accuracy on frequency output.....	Max. error: 0.2 % of full scale
Resolution on frequency output	10 bit

The digital output is galvanically isolated from the supply voltage (PELV) and other high-voltage terminals.

Control card, analog output:

Number of programmable analog outputs.....	1
Terminal number.....	42
Current range at analog output.....	0/4 - 20 mA
Max. load to common at analog output	500 Ω
Accuracy on analog output	Max. error: 1.5 % of full scale
Resolution on analog output.....	10 bit

The analog output is galvanically isolated from the supply voltage (PELV) and other high-voltage terminals.

Control card, 24 V DC output:

Terminal number	12
Max. load supplied from mains / 24 V external.....	240/65 mA

The 24 V DC supply is galvanically isolated from the supply voltage (PELV), but has the same potential as the analogue and digital inputs and outputs.

Control card, 10 V DC output:

Terminal number	50
Output voltage	10.5 V ±0.5 V
Max. load	15 mA

The 10 V DC supply is galvanically isolated from the supply voltage (PELV) and other high-voltage terminals.

Control card, RS 485 serial communication:

Terminal number.....	68 (TX+, RX+), 69 (TX-, RX-)
Terminal number 67	+ 5 V
Terminal number 70	Common for terminals 67, 68 and 69

Full galvanic isolation.

Relay outputs:

Number of programmable relay outputs	1
Terminal number, control card	1-3 (break), 1-2 (make)
Max. terminal load (AC) on 1-3, 1-2, control card	240 V AC, 2 A

Min. terminal load on 1-3, 1-2, control card 24 V DC 10 mA, 24 V AC 100 mA The relay contact is separated from the rest of the circuit by strengthened isolation.

External 24 Volt DC supply:

Terminal nos	35, 36
Voltage range	21-28 V (max. 37 V DC for 10 sec.)
Max. voltage ripple	2 V DC
Power consumption with/without mains supply	<1W/5-12W

Reliable galvanic isolation: Full galvanic isolation if the external 24 V DC supply is also of the PELV type.

Cable lengths and cross sections:

Max. motor cable length, screened/armoured cable.....	10 m
Max. motor cable length, unscreened/unarmoured cable.....	10 m
Max. cross section to control wires, rigid wire	4.0 mm ² /10 AWG
Max. cross section to control cables, flexible cable	2.5 mm ² /12 AWG
Max. cross section to control cables, cable with ferrules....	2.5 mm ² /12 AWG
Max. cross section extra terminals for 24 V ext, T73 version, rigid cables	6.0 mm ² /9 AWG
Max. cross section extra terminals for 24 V ext, T73 version, flexible cable.....	4 mm ² /10 AWG
Max. cross section extra terminals for 24 V ext, T73 version, cable with ferrules.....	4 mm ² /10 AWG
Max. cross section PE.	10 mm ² /7 AWG
Max. cross section external PE for T73 version	16 mm ² / 5 AWG

If U/L/CUL is to be complied with, cable with temperature class 60/75°C must be used. Use copper wires only.

VLT® Motor Starter DMS 300

The VLT® Decentral Motor Starter DMS 300 is part of the Danfoss decentral motor control concept with a common mechanical design.

Variable speed applications using the decentral frequency converter (FCD 300) can be used together with fixed speed applications using a starter or soft starter.

The decentral motor switch DMS 300 can be mounted on or close to the motor, or on a wall. The DMS 300 comes with a smooth cleaning friendly IP66 enclosure with a robust painted surface.

It performs six main functions:

- Start control, including soft start.
- Stop control, including soft stop (extended stop time).
- Thermistor motor protection
- Electronic motor protection (optional).
- Electromechanical brake control (optional)
- Monitoring & system interface.

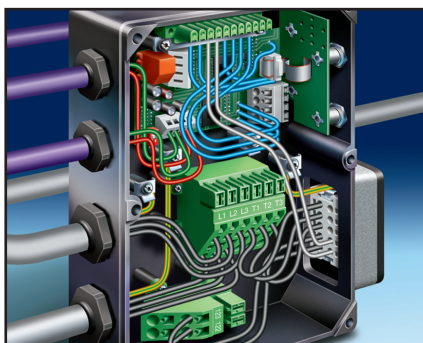

Construction

The DMS unit is made of two separable parts:

1. Installation box, which is the bottom half. The installation box has all the mounting arrangement, cable entries, and earthing studs.
2. Electronics Module, which is the top half. The electronics module contains all the circuitry of the DMS.



Hygienic

The electronics are protected in small, tight, robust, dirt repelling enclosures that can be mounted anywhere. This way it meets such conditions found in the food and beverage industry, where frequent wash downs are required.

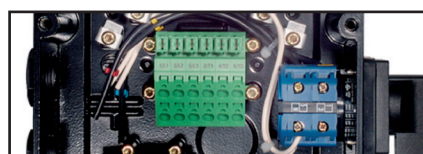

Service switch

Lockable service switch is integrated making local disconnect possible on either mains or motor side.



Busconnection

DMS units can be offered as variants with Profibus communication option and 4 x M12 sensor plugs.

Specifications

Supply (L1, L2, L3, 125, 126, 127, 128):

Mains Supply voltage 3 x 380 VAC ~ 480 VAC +/- 10%
Mains Supply frequency 45HZ ~ 65 Hz
Electronics control voltage +24VDC (20V to 30V), 150mA nominal

Control Inputs:

Start (Terminals 18 & 19).....Binary, 24 VDC, 8mA approx.
Reset/ Coasting stop inverse
(Terminal 27) Binary, 24 VDC, 90mA approx. #
Release Electromechanical Brake
(Terminal 124)Binary, 24 VDC, 8mA approx.

*The Control inputs are suitable for connection to a device with a PNP output stage.
20 mA approx. for Standrad versions (SB & ST)*

Outputs:

Run Output
(Terminal 46) Binary, PNP output, 24 VDC, 20mA max.
The output is short circuit protected.
Electromechanical Brake Supply output
Electromechanical Brake Supply Output
(Terminals 122 & 123) 180 VDC, 1.0 A max. *

** The electromechanical brake supply output voltage is proportional to the mains supply voltage, which is 180 VDC for 400VAC mains, 205 VDC for 460 VAC mains. The output is not short circuit protected.*

Operating temperature -10 to +60 deg. C (above 40 deg. with derating)
Relative humidity 5 -90%RH, non-condensing
Weight 3.5 kg

Certifications:

The DMS 300 has CE, UL, cUL and C-tick certifications.
The details are as under:

CE

Declared as conforming to EEC directive relating to Electrical Equipment designed for use within certain voltage limits (73/23/EEC) and Electromagnetic Compatibility (89/336/EEC).
Conforms to IEC/EN 60947-4-2 Form 2

Rated insulation voltage..... 500 VAC
Rated impulse withstand..... 2.0 kV (1.2/ 50 micro second)
Conducted and radiated frequency emissionsClass B as per EN 55011

Electrostatic discharge, 4 kV contact and 8 kV air discharge
no effect on operation.
Radio frequency electromagnetic field,
0.15 MHz to 1.0 GHz no effect on operation.

Fast transients, 2.0 kV/ 5.0 kHz..... no effect on operation
Surges, 2.0 kV line to earth, 1.0 kV line to line..... no effect on operation
Voltage dips and short interruptions no effect on operation

Short circuit tested on 5 kA supply, when protected
by semiconductor fuses (Type. 2 co-ordination) no damage to
DMS 300, no danger to persons or installation.
Short circuit tested on 5 kA supply, when protected by HRC fuses
(Type 1 co-ordination) no danger to persons or installation,
DMS unit may be unsuitable for future use.

UL

Conforms to the requirements of UL certification (reference number E206590)

C-tick

Conforms to IEC/EN 60947-4-2.

IP66

Degree of protection of the enclosure conforms to IEC/EN 60947-1
To maintain certifications, the product shall not be modified in any way, shall be used only for the specified purpose, and must be installed according to this manual and/or any other authorized Danfoss instruction.

Run Output (Terminal 46)

Binary, PNP output, 24 VDC, 20mA max. The output is short circuit protected.

Electromechanical Brake Supply output

Electromechanical Brake Supply Output
(Terminals 122 & 123) 180 VDC, 1.0 A max. *

** The electromechanical brake supply output voltage is proportional to the mains supply voltage, which is 180 VDC for 400VAC mains, 205 VDC for 460 VAC mains. The output is not short circuit protected.*

Operating temperature -10 to +60 deg. C (above 40 deg. with derating)
Relative humidity 5 -90%RH, non-condensing
Weight 3.5 kg

VLT® Soft Starter MCD 100

MCD 100 is a cost effective and extremely compact soft starter for AC motors up to 11 kW. Due to a unique semiconductor design MCD 100 is a true "fit and forget" product. Selection can be made on the basis of the motor power – exactly as with traditional contactors.

The range features three different products, MCD 100-001 (1,5 kW), MCD 100-007 (7,5 kW) and MCD 100-011 (11 kW). All sizes are rated for line voltage up to 600 V AC.

MCD 100 products provide timed voltage ramp up and down. Ramp time can be individually adjusted with rotary switches from 0,4 to 10 seconds. The start torque can be adjusted from 0 to 85% of the direct on-line torque.

- A robust semiconductor design – selection can be based on motor power which ensures easy selection.
- Can be used for an almost unlimited number of starts per hour without derating.
- A universal control voltage (24-480 V AC/ V DC) – simplifies selection and keeps stock at a minimum.
- A "fit and forget" contactor design – simplifies installation and reduces required panel space.
- Digitally controlled rotary switches – secures precise settings and simplifies installation.
- Ratings for heavy duty as standard – simplifies installation and reduces the risk of breakdown

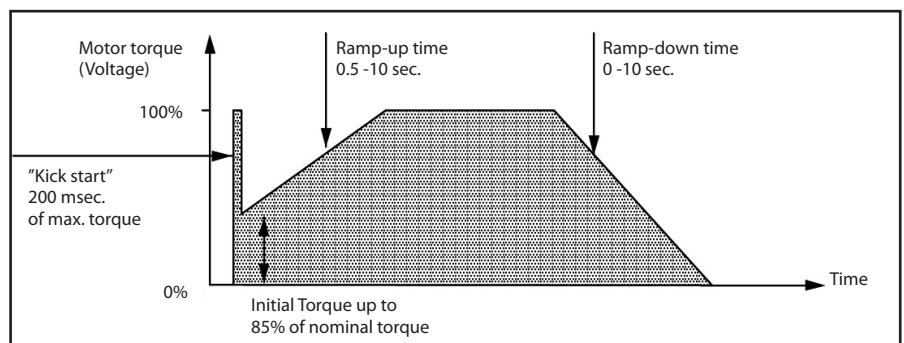

Timed voltage ramp

- Micro Soft Start Controller for motors up to 11kW
- Extremely robust SCR design with heavy ratings as standard
- Unlimited number of starts per hour
- Contactor style design for easy selection, installation and commissioning

Specifications

Mains supply (L1, L2, L3):

MCD 100 3 x 208 VAC ~ 600 VAC (+10% / - 15%)
Supply frequency (at start) 45Hz - 66 Hz

Control circuit (A1, A2):

MCD 100 24 – 480 VAC/VDC (-15% +10%)

Environmental:

Degree of protection MCD 100 IP20
Operating Temperatures -50°C / +40°C (60°C with de-rating)
Pollution Degree Pollution Degree 3

EMC Emission:

Equipment class (EMC) Class A
Conducted radio frequency emission 0.15 MHz - 0.5 MHz : <90dB(μV)
Conducted radio frequency emission 0.5 MHz - 5 MHz : <76dB(μV)
Conducted radio frequency emission 5 MHz - 30 MHz : 80-60dB(μV)
Radiated radio frequency emission 30 MHz - 230 MHz : <30dB(μV/m)
Radiated radio frequency emission 230 MHz - 1000 MHz : <37dB(μV/m)

This product has been designed for Class A equipment. Use of the product in domestic environments may cause radio interference, in which case the user may be required to employ additional mitigation methods.

EMC Immunity:

Electro static discharge 4 kV contact discharge, 8 kV air discharge
Radio-frequency electromagnetic field 0.15 MHz - 1000 MHz: 140dB(μV)
Rated impulse withstand voltage (Fast transients 5/50 ns - Burst) 4 kV line to earth
Rated insulation voltage (Surges 1.2/50 μs – 8/20 μs) 4 kV line to earth, 2 kV line to line
Voltage dip and short time interruption 100 ms (at 40% nominal voltage)

Short Circuit:

Rated short-circuit current MCD 100-001 normal fuses: 25 A gL / gG
SCR I2t rating for semiconductor fuses: 72 A2s
Rated short-circuit current MCD 100-007 normal fuses: 50 A gL / gG
SCR I2t rating for semiconductor fuses: 1800 A2s
Rated short-circuit current MCD 100-011 normal fuses: 80 A gL / gG
SCR I2t rating for semiconductor fuses: 6300 A2s

Heat Dissipation:

MCD 100-001 max. 4 watts
MCD 100-007 to MCD 100-011 2 watts / Ampere

Standards Approvals:

UL / C-UL UL508
CE IEC 60947-4-2

VLT® Compact Starter MCD 200

The Compact Starter MCD 200 cover the power range 7.5 – 110 kW.

Due to extensive use of the latest technology, such as new semiconductor control algorithms and bypass design, the new soft starters are very compact and heat dissipation is at a very low level. There is no need for extra ventilation or bypass contactors. This simplifies installation and keeps panel space at a minimum.

The MCD 200 features a variety of accessories. Add-on modules provide essential serial communication and a Remote Operator module allows for remote control and motor performance monitoring, which makes MCD 200 ideal for panel installation.

MCD 200 comes in two versions. MCD 201 is the basic version offering timed voltage ramps, MCD 202 is the advanced version providing current limit soft start, timed voltage ramp down, and motor protection.

- Current ratings for normal and heavy starting
- Versions for 200- 575 VAC
- Voltage ramps or current limit ramp soft start
- Built-in motor protection
- Compact design with internal bypass system for minimum power loss
- Add on modules for remote operation and serial communication
- Software for sizing, control and monitoring

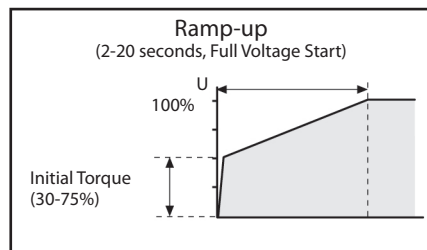

Timed voltage ramp MCD 201

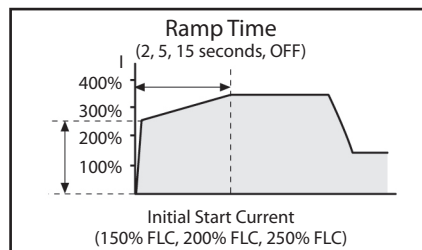

Current Limit MCD202:

- Compact Soft Starter for motors up to 110kW
- Voltage ramps, current limit start and integrated motor protection
- Integral bypass design reduce heat dissipation
- Wide power range with advanced accessory modules



Optional:

- Modules for serial communication
- Remote operation kit
- PC software
- Remote operation kit

Specifications

Mains supply (L1, L2, L3):

MCD 200-xxx-T4-xxx	3 x 200 VAC ~ 440 VAC (+10% / - 15%)
MCD 200-xxx-T6-xxx	3 x 200 VAC ~ 575 VAC (+10% / - 15%)
Supply frequency (at start)	45Hz - 66 Hz
Supply frequency	48-62 Hz +/- 1%

Control supply (A1,AL2,A3):

MCD 200-xxx-xx-CV1	24 VAC/VDC (±20%)
MCD 200- xxx-xx-CV3	110-240VAC (+10% / - 15%) or 380-440 VAC (+10% / - 15%)

Control Inputs:

Start Terminal N1	Normally Open, 300 VAC max.
Stop Terminal N2	Normally Closed 300 VAC max.

Relay Outputs:

Main Contactor (Terminals 13 & 14)	Normally Open
Main Contactor (Terminals 13 & 14)	6A, 30 VDC resistive / 2 A, 400 VAC, AC11
Programmable Relay (Terminals 23 & 24)	Normally Open
Programmable Relay (Terminals 23 & 24)	6A, 30 VDC resistive / 2 A, 400 VAC, AC11

Environmental:

Degree of protection MCD 200-007 to MCD 200-055	IP20
Degree of protection MCD 200-075 to MCD 200-110	IP00
Operating Temperatures	-10oC / +60oC
Humidity	5%-95% Relative Humidity
Pollution Degree	Pollution Degree 3
Vibration	IEC 60068 Test Fc Sinusoidal
Vibration	4Hz - 13.2Hz: ± 1mm displacement
Vibration	13.2Hz - 100Hz: ± 0.7g

EMC Emission:

Equipment class (EMC)	Class A
Conducted radio frequency emission	0.15 MHz - 0.5 MHz : <90dB(µV)
Conducted radio frequency emission	0.5 MHz - 5 MHz : <76dB(µV)
Conducted radio frequency emission	5 MHz - 30 MHz : 80-60dB(µV)
Radiated radio frequency emission	30 MHz - 230 MHz : <30dB(µV/m)
Radiated radio frequency emission	230 MHz - 1000 MHz : <37dB(µV/m)

This product has been designed for Class A equipment. Use of the product in domestic environments may cause radio interference, in which case the user may be required to employ additional mitigation methods.

EMC Immunity:

Equipment class (EMC)	4 kV contact discharge, 8 kV air discharge
Radio-frequency electromagnetic field	0.15 MHz - 1000 MHz: 140dB(µV)
Rated impulse withstand voltage (Fast transients 5/50 ns)	2 kV line to earth
Rated insulation voltage (Surges 1.2/50 µs – 8/20 ms)	2 kV line to earth, 1 kV line to line
Voltage dip and short time interruption	100 ms (at 40% nominal voltage)

Short Circuit:

Rated short-circuit current MCD 200-007 to MCD 200-037	5 kA
Rated short-circuit current MCD 200-045 to MCD 200-110	10 kA

Heat Dissipation:

During Start	3 watts / Ampere
During Run	< 4 watts

Standards Approvals:

C-tick	IEC 60947-4-2
UL / C-UL	UL508
CE	IEC 60947-4-2
CCC	GB 14048.6

VLT® Soft Starter MCD 3000

The VLT® MCD 3000 soft starters cover the power range 7,5 – 800 kW.

MCD 3000 is a total motor starting solution. Current transformers measure the motor current and provide feedback for controlled motor voltage ramp up, but also for numerous motor protection functions. A numeric display and logic keypad buttons makes programming easy and operational status such as motor current is shown via the display.

The MCD 3000 is wall mountable, however a Remote Operator module allows for remote control and motor performance monitoring making it ideal for panel installation.

- Current ratings for normal and heavy starting
- Versions for 200 – 690 VAC
- Current limit soft start with initial current ramp up
- Four different auto-adjustable ramp down profiles
- Numerous motor protection features
- Built-in local control panel with display
- Pass word protection of parameters
- DC brake function
- Internal delta wiring kit
- Software for sizing, control and monitoring

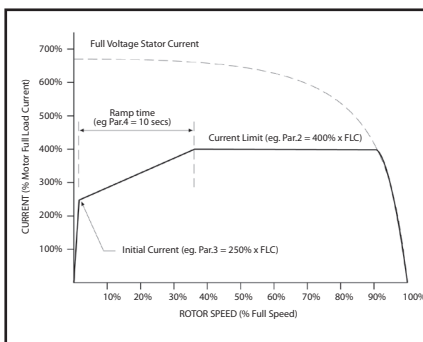

Current ramp

MCD 3000

- Fully featured Soft Starter for motors up to 800 kW
- Total motor starting solution
- Advanced start, stop and protection features
- Local programming keypad and display

Optional:

- Modules for serial communication
- Remote operator kit
- PC software



Remote operation kit

- Start/stop, reset
- LED for start, run, trip
- Trip codes
- Current display
- Motor temp. display
- 4 – 20 mA output

Specifications

Mains supply (L1, L2, L3):

Supply voltage MCD3000-T5	3 x 200 VAC ~ 525 VAC
	3 x 200 VAC ~ 440 VAC (Inside Delta Connection)
Supply voltage MCD3000-T7	3 x 200 VAC ~ 690VAC
	3 x 200 VAC ~ 440 VAC (Inside Delta Connection)
Supply frequency (at start)	50HZ (± 2Hz) / 60 Hz (± 2Hz)
Supply frequency (during start)	>45Hz (50Hz supply) or >55Hz (60 Hz supply)
Supply frequency (during run)	>48Hz (50Hz supply) or >58Hz (60 Hz supply)
Electronics control voltage	230 VAC (+10%/-15%) or 400 VAC (+10%/-15%)

Control Inputs:

Start (Terminals 15 & 16)	Normally Open, Active 24 VDC, 8mA approx.
Stop (Terminals 17 & 18)	Normally Closed, Active 24 VDC, 8mA approx.
Reset (Terminals 25 & 26)	Normally Closed, Active 24 VDC, 8mA approx.
Parameter Set (Terminals 27 & 28)	Normally Open, Active 24 VDC, 8mA approx.

Relay Outputs:

Programmable Output A1 (Terminals 13 & 14)	Normally Open, 5 A @ 250 VAC/360 VA, 5 A @ 30 VDC resistive
Programmable Output B2 (Terminals 21, 22 & 24)	Changeover, 5 A @ 250 VAC/360 VA, 5 A @ 30 VDC resistive
Output C3 (Terminals 33 & 34)	Normally Open, 5 A @ 250 VAC/360 VA, 5 A @ 30 VDC resistive
1) Programmable functions:	Line contactor, Run, High current flag, Low current flag
2) Programmable functions:	Tripped, Output on, High current flag, Low current flag, Line contactor
3) Programmable functions:	Run, D.C.Brake Contactor Control, Off

Environmental:

Degree of protection MCD3007 to MCD3132	IP21
Degree of protection MCD3185 to MCD3800	IP20
Operating Temperatures	-5oC / +60oC
Rated short-circuit current (with semi-conductor fuses)	100kA
Rated insulation voltage (Surges)	2 kV line to earth, 1kV line to line
Rated impulse withstand voltage (Fast transients)	2 kV
Pollution Degree	Pollution Degree 3
Electro static discharge	4 kV contact discharge, 8 kV air discharge
Equipment class (EMC)	Class A
Radio-frequency electromagnetic field	0.15 MHz - 80 MHz: 140dBµV 80 MHz - 1 GHz: 10 V/m

This product has been designed for Class A equipment. Use of the product in domestic environments may cause radio interference, in which case the user may be required to employ additional mitigation methods.

Standards Approvals:

C√	CISPR-11
UL1	UL508
C-UL1	CSA 22.2 No. 14
CE	IEC 60947-4-2

1) Requires use of semi-conductor fuses. Excludes models MCD3600~MCD3800

VLT® Harmonic Filter AHF 005/010

The Danfoss AHF 005 and AHF 010 are advanced harmonic filters not to be confused with traditional harmonic trap filters. The Danfoss harmonic filters have been specially designed to match the Danfoss frequency drives.

AHF 010 reduces the harmonic current to less than 10% and the AHF 005 reduces the harmonic current to less than 5%.

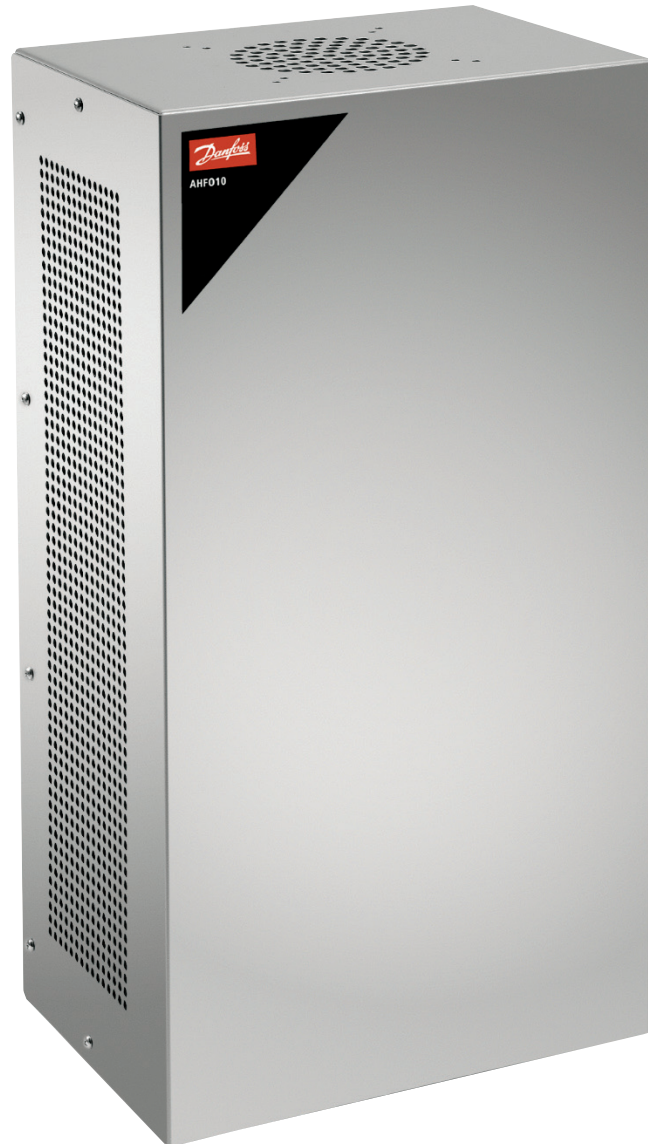

Excellent performance

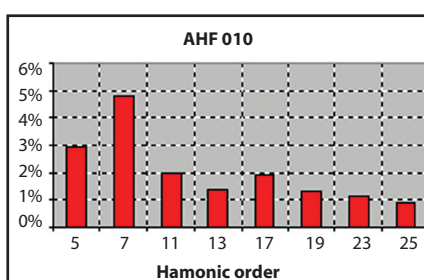
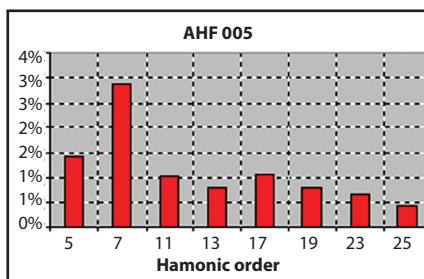

Danfoss harmonic filters perform excellently.

The figures show the reduction of each of the sub-harmonic orders at full load.

Calculation Danfoss has created a PC based program MCT31 for calculation of harmonics with different principles for suppression. It can calculate the harmonics for Danfoss Frequency Converters depending on actual system (transformer, cables, other loads etc.)

Features

- Small compact housing that fits into a panel
- Easy to use in retrofit applications
- AHF 010 reduces the total harmonic current distortion to 10%
- AHF 005 reduces the total harmonic current distortion to 5%
- One filter module can be used for several frequency drives
- High efficiency (> 0.98)
- User-friendly commissioning – no adjustment necessary
- No routine maintenance required

Specifications

General technical data:

The reduction of the low harmonic current emission to the rated THiD implies, that the THvD of the non-influenced mains voltage is lower than 2% and the ratio of short circuit power to installed load (R SCE) is at least 66%.

Under these conditions the THiD of the mains current of the frequency converter is reduced to 10% or 5% (typical values at nominal load).

If these conditions are not or only partially fulfilled, a significant reduction of the harmonic components can still be achieved, but the rated THiD values may not be achieved.

VLT® DriveMotor FCM 300

The VLT® FCM 300 Series is a very compact alternative to the traditional solution with a VLT® frequency converter and motor as separate units. The frequency converter is attached in place of the motor terminal box. It is no higher than the standard terminal box – not wider nor longer than the motor.

Benefits

- Motor and drive perfectly matched to each other
- No panel space required – the DriveMotor is placed on the machine
- Simplified installation
- No power cable length limitation
- Straightforward EMC compliance
- Flexible mounting – face-flange, foot/flange, foot/face
- Retrofit without mechanical changes

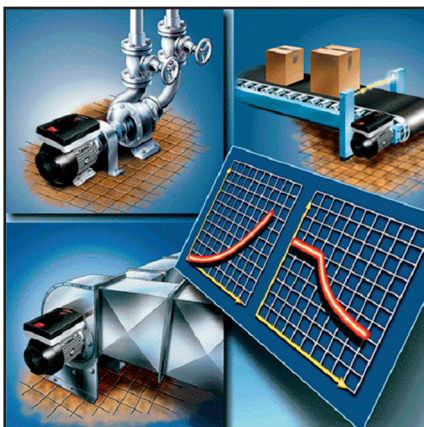

FCM applications

Typical applications are air handling units, pumps, conveyors and small machines for example labelling machines.



Control panel

Local control panel is used for operating, drivemotor setup and diagnostics. The LCP can be handheld or mounted in a panel front (IP 65).

Operation Pad

A local operation pad can be used for speed up/speed down, start/stop, and jog e.g.. Other features are speed indication by LED, mounting on FCM or kit for wall mounting.



Communication

- RS 485 serial port as standard
- Profibus DP version (3 or 12 Mbaud)

Specifications

Mains supply, TT, TN and IT* (L1, L2, L3):

Supply voltage 380-480 V units.....	3 x 380/400/415/440/460/480 V $\pm 10\%$
Supply frequency	50/60 Hz
Max. imbalance of supply voltage	$\pm 2\%$ of rated supply voltage
Power factor / $\cos \varphi$	max. 0.9/1.0 at rated load
No. of switching operations on supply input L1, L2, L3.....	approx. 1 time/2 min

**) Not valid for RFI class 1B units*

Torque characteristics:

Starting torque/overload torque.....	160 % for 1 min
-Continuous torque.....	see above

Control card, digital/pulse inputs:

Number of programmable digital inputs.....	4
Terminal nos.....	X101-2, -3, -4, -5
Voltage level	0-24 V DC (PNP positive logics)
Voltage level, logic '0'	< 5 V DC
Voltage level, logic '1'	> 10 V DC
Maximum voltage on input	28 V DC
Input resistance, Ri.....	aprox 2 k Ω
Scanning time.....	20 msec

Control card, pulse input:

No. of programmable pulse inputs.....	1
Terminal nos.	X101-3
Max. frequency on terminal 3, open collector/push pull 24 V	8 kHz/70 kHz
Resolution	10 bit
Accuracy (0.1-1 kHz), terminal 3	Max. error: 0.5% of full scale
Accuracy (1-12 kHz), terminal 3	Max. error: 0.1% of full scale

Control card, analogue inputs:

No. of programmable analogue voltage inputs	1
Terminal nos.....	X101-2
Voltage level	0 - 10 V DC (scalable)
Input resistance, Ri.....	approx. 10 k Ω
No. of programmable analogue current inputs	1
Terminal no.	X101-1
Current range	0 - 20 mA (scalable)
Input resistance, Ri.	approx. 500 k Ω
Resolution	9 bit
Accuracy on input	Max. error 1% of full scale
Scanning time	20 msec.

Control card, digital/pulse and analogue outputs:

No. of programmable digital and analogue outputs	1
Terminal nos.....	X101-9
Voltage level at digital output/load.....	0 - 24 V DC/25 mA
Current at analogue output ..	0 - 20 mA
Maximum load to frame (terminal 8) at analogue output	RLOAD \leq 500 Ω
Accuracy of analogue output ...	Max. error: 1.5% of full scale
Resolution on analogue output.8 bit

Relay output:

No. of programmable outputs	1
Terminal nos.....	1-2 (make), 1-3 (brake) terminal X102
Voltage level at contact/load (AC).	250 V AC, 5A-AC load
Voltage level at contact/load (DC) .	30 V DC, 5A; 40 V DC, 2A . 100 V DC, .0.5A

Control card, RS 485 serial communication:

Terminal nos.....	X100-1, -2
-------------------	------------

Control characteristics (frequency converter):

Frequency range.....	0 - 132 Hz
Resolution on output frequency	0.1 %
System response time.....	Max. 40 msec.
Speed accuracy (open loop, CT mode, 4 P motor driven in speed range 150-1500 rPm).....	+/- 15 rpm

VLT® Motion Control Tool MCT 10

Setup software provides easy control of details as well as a general overview of systems, large or small.

- Handles all drive related data
- One PC tool for all tasks
- Handles all drives products and parameters
- "Explorer-like" view
- Option programming
- Online and offline commissioning
- Scope & logging
- Alarm history
- Multiple interfaces for easy connection
- USB
- Profi bus
- RS485
- Internet download
<http://www.danfoss.com/drives>

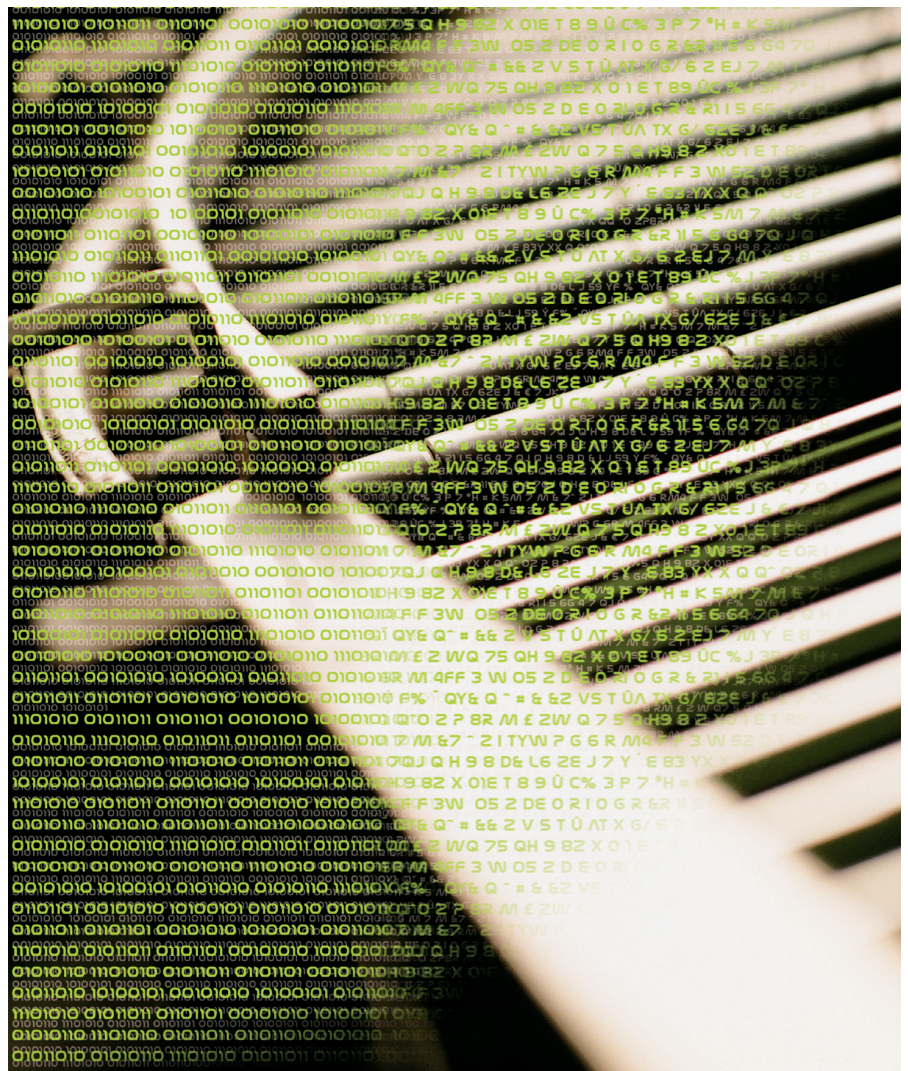

Features



Basic:

- Scope & Graph
- Alarm history in saved projects
- No limitation in number of drives
- SyncPos support

Advanced:

- PROFIsafe option
- Copy protected "HW dongle"

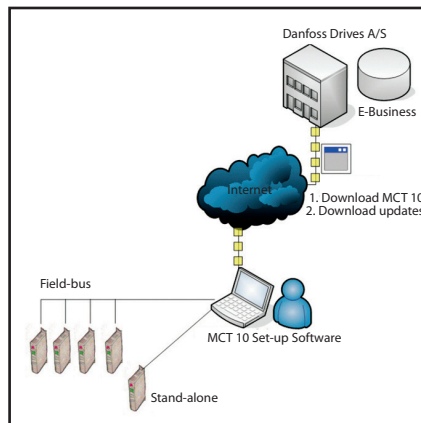

More efficient commissioning

- Off-line commissioning offsite
- Save/send/mail projects anywhere
- Easy field-bus handling, multiple drives in project file. Enables service organization to be more efficient

Enables service organization to be more efficient

- Scope & logging: analyse problems easily
- Read out alarms, warnings and fault log in one view.
- Compare saved project with on-line drive

System requirements

- MS Windows® NT 4.0, 2000 and XP
- Pentium III 350 MHz or better
- 256 Mb RAM or better
- 200Mb free hard disk space
- CD-ROM drive
- VGA or XGA graphic adapter
- Mouse

VLT® Service – Your Way

DrivePro™ is an efficient productivity programme tailored to meet your specific needs. All the necessary VLT® service facilities are at your disposal, which will minimize downtime and increase productivity at your factory. This means that DrivePro™ pays for itself in no time.

DrivePro™ service products are designed to be customised and combined.



Keep you running

Current drives update

The SmartStep service programme ensures that Danfoss Products are replaced before breakdown.

Commissioning and regular adjustments

The mechanical condition of machinery changes over time. Regular adjustments can prevent failure messages and production stops.

Preventive maintenance

Proactive maintenance gives you the peace of mind that comes with knowing your drives have been properly inspected and maintained.

Keep you fit

Training

Specialised service courses enable your own maintenance staff to carry out troubleshooting and service.

Stock maintenance & consignment

The DrivePro™ stock maintenance & consignment programme provides two variants of stock properties. Danfoss ensures the best choice of equipment is present at the stock.

Harmonic Survey

The DrivePro™ Harmonic Survey covers the installation of relevant instruments, as well as analysis and consultancy regarding actions to be taken.

Environmentally sound disposal

Danfoss provides controlled environmentally sound disposal of redundant drives in line with local requirements.

Fix your costs

Fixed price

Stick to your drive repair budget. Material, labour and transport to a Danfoss lab are included.

Post-warranty agreement

After the 12-month factory warranty expires, you can extend your warranty up to 5 years. Contact your local Danfoss office for an extended warranty.

Transport insurance

Danfoss takes full responsibility for damage to drives in transit. No complicated procedures. A simple note, and Danfoss will fix it.

Response time

Customised fast response service night and day keeps processes running.

Sales and Service Contacts worldwide

• 24/7 availability • Local hotlines and local language • Local stock

Albania

danfoss@danfoss.gr
Tel: +30 210 94 11 744
Fax: +30 210 94 11 757

Angola

danfoss@danfoss.co.za
Tel: +27 11 803 8390
Fax: +27 11 803 8244

Argentina

argentina@danfoss.com
Tel: +54 11 4756 4200
Fax: +54 11 4756 4100

Equitecnica S.A.

service@equitecnica.com.ar
Tel: +54 11 49124590
Fax: +54 11 49112382

Armenia

info@danfoss.ru
Tel: +7 095* 792 57 57
Fax: +7 095* 792 57 59

Aruba

scdivision@danfossmt.com.mx
Tel: +52 81 8156 5683
Fax: +52 81 8156 5625

Australia

danfoss@danfoss.com.au
Tel: +61 (3) 9703 5100
Fax: +61 (3) 9703 5159

Austria

danfoss.at@danfoss.com
Tel: +43 (2236) 5040
Fax: +43 (2236) 5040 Ext. 43

Azerbaijan

info@danfoss.ru
Tel: +7 095* 792 57 57
Fax: +7 095* 792 57 59

Bahrain

danfoss@emirates.net.ae
Tel: +917 4 88 72220
Fax: +917 4 88 72221

Bangladesh

danfoss.india@danfoss.com
Tel: +91 (44) 55501555
Fax: +91 (44) 55501444

Barbados

scdivision@danfossmt.com.mx
Tel: +52 81 8156 5683
Fax: +52 81 8156 5625

Belarus

info@danfoss.com
Tel: +7 095* 792 57 57
Fax: +7 095* 792 57 59

Belgium

info@danfoss.be
Tel: +32 2 525 07 11
Fax: +32 2 525 07 57

Belize

scdivision@danfossmt.com.mx
Tel: +52 81 8156 5683
Fax: +52 81 8156 5625

Benin

o_schenberg@danfoss.fr
Tel: +33 1 30 62 50 00
Fax: +33 1 30 62 51 93

Bosnia-Herzegovina

Tel: +385 1 606 40 70
Fax: +385 1 606 40 80

Botswana

danfoss@danfoss.co.za
Tel: +27 11 803 8390
Fax: +27 11 803 8244

Brazil

wisantos@danfoss.com
Tel: +55 (11) 2135 5400
Fax: +55 (11) 2135 5455

Bulgaria

danfoss.bg@danfoss.com
Tel: +359 (2) 94 54 338
Fax: +359 (2) 8409194

Burkina Faso

c_piriou@danfoss.fr
Tel: +33 1 30 62 50 00
Fax: +33 1 30 62 51 93

Burundi

o_schenberg@danfoss.fr
Tel: +33 1 30 62 50 00
Fax: +33 1 30 62 51 93

Cameroon

o_schenberg@danfoss.fr
Tel: +33 1 30 62 50 00
Fax: +33 1 30 62 51 93

Canada

heatingsales@danfoss.ca
Tel: +1 (905) 6766000
Fax: +1 (905) 6760279

Central Africa

o_schenberg@danfoss.fr
Tel: +33 1 30 62 50 00
Fax: +33 1 30 62 51 93

Chile

chile@danfoss.com
Tel: +56 (2) 5200800
Fax: +56 (2) 7391055

China

Tel: +86 10 6581 4800
Fax: +86 10 6581 4825

Colombia

Tel: +57 2 439 8888
Fax: +57 2 439 1909

Costa Rica

scdivision@danfossmt.com.mx
Tel: +52 81 8156 5683
Fax: +52 81 8156 5625

Croatia

danfoss.hr@danfoss.com
Tel: +385 (1) 6064070
Fax: +385 (1) 6064080

Cuba

scdivision@danfossmt.com.mx
Tel: +52 81 8156 5683
Fax: +52 81 8156 5625

Ciniesia

Tel: +53 7 24 14 24
Fax: +53 7 24 17 25

Cyprus

n.pavliades@cytanet.com.cy
Tel: +357 99451265
Fax: +357 25340608

Czech Republic

danfoss.cz@danfoss.com
Tel: +420 (2) 83014111
Fax: +420 (2) 83014123

Denmark

danfossdk@danfoss.dk
Tel: +45 8948 9111
Fax: +45 8948 9311

Djibouti

c_piriou@danfoss.fr
Tel: +33 1 30 62 50 00
Fax: +33 1 30 62 51 93

Dominican Republic

scdivision@danfossmt.com.mx
Tel: +52 81 8156 5683
Fax: +52 81 8156 5625

Ecuador

controles@maquinarias-henriques.com
Tel: +593 (4) 2254300
Fax: +593 (4) 2254300

Egypt

avakimpex@avak.com
Tel: +20 (2) 5261177
Fax: +20 (2) 5261188

El Salvador

scdivision@danfossmt.com.mx
Tel: +52 81 8156 5683
Fax: +52 81 8156 5625

Estonia

danfoss@danfoss.ee
Tel: +372 6 59 33 00
Fax: +372 6 59 33 01

Finland

info@danfoss.fi
Tel: +358 9 802 81
Fax: +358 9 802 8425

France

danfoss@danfoss.fr
Tel: +33 (1) 30625000
Fax: +33 (1) 30697470

Gambia

o_schenberg@danfoss.fr
Tel: +33 1 30 62 50 00
Fax: +33 1 30 62 51 93

Georgia

info@danfoss.ru
Tel: +7 095* 792 57 57
Fax: +7 095* 792 57 59

Germany

info-drives@danfoss-sc.de
Tel: +49 (69) 89020
Fax: +49 (69) 8902324

Ghana

o_schenberg@danfoss.fr
Tel: +33 1 30 62 50 00
Fax: +33 1 30 62 51 93

Great Britain

Great Britain
UK.drives.Sales@danfoss.com
Tel: +44 0870 241 07100
Fax: +44 0870 241 7150

Greece

danfoss@danfoss.gr
Tel: +30 210 94 11 744
Fax: +30 210 94 11 757

Guatemala

scdivision@danfossmt.com.mx
Tel: +52 81 8156 5683
Fax: +52 81 8156 5625

Honduras

scdivision@danfossmt.com.mx
Tel: +52 81 8156 5683
Fax: +52 81 8156 5625

Hong Kong

hksc@danfoss.com.hk
Tel: +852 (25) 173872
Fax: +852 (25) 173908

Hungary

danfoss.hu@danfoss.com
Tel: +36 (1) 450 2531
Fax: +36 (1) 450 2539

Iceland

danfoss@danfoss.is
Tel: +354 510 4100
Fax: +354 510 4110

India

ramesh_reddy@danfoss.com
Tel: +91 (40) 27955270
Fax: +91 40 3222009

Indonesia

indonesia@danfoss.com
Tel: +62 (21) 83790621
Fax: +62 (21) 83790620

Iran

danfoss@emirates.net.ae
Tel: +971 4 88 72 220
Fax: +971 4 88 722221

Iraq

kholoudcom@yahoo.com
Telephone: +964 1 778 2987

Ireland

marketing@danfoss.ie
Tel: +353 (01) 626 8111
Fax: +353 (01) 626 9334

Israel

mngmnt@radion.co.il
Tel: +972 (3) 922 6688
Fax: +972 (3) 922 6655

Italy

Tel: +39 (011) 3000511
Fax: +39 (011) 3000573

Jamaica

scdivision@danfossmt.com.mx
Tel: +52 81 8156 5683
Fax: +52 81 8156 5625

Japan

danfoss-shoki@saginomiya.co.jp
Tel: +81 3 3330 1120

Jordan

nicolaco@go.com.jo
Tel: +962 (6) 585 9472
Fax: +962 (6) 585 9473

Kazakhstan

info@danfoss.kz
Tel: +7 3272 93 95 05
Fax: +7 3272 93 82 93

Kenya

danfoss@danfoss.co.za
Tel: +27 11 803 8390
Fax: +27 11 803 8244

Korea (South)
danfosskorea@danfoss.com
Tel: +82 (2) 567-0090
Fax: +82 (2) 569-2894

Kuwait
danfoss@emirates.net.ae
Tel: +971 4 88 72220
Fax: +971 4 88 72221

Kyrgyzstan
info@danfoss.ru
Tel: +7 095* 792 57 57
Fax: +7 095* 792 57 59

Latvia
danfoss@danfoss.lv
Tel: +371 7 339166
Fax: +371 7 36 13 13

Lesotho
danfoss@danfoss.co.za
Tel: +27 11 803 8390
Fax: +27 11 803 8244

Liberia
o_schenberg@danfoss.fr
Tel: +33 1 30 62 50 00
Fax: +33 1 30 62 51 93

Libya
Please contact Danfoss
in South Africa

Lithuania
danfoss@danfoss.lt
Tel: +370 52105 740
Fax: +370 52 335 355

Macedonia
danfoss.yu@danfoss.com
Tel: +381 11 313 0620
Fax: +381 11 313 0636

Madagascar
o_schenberg@danfoss.fr
Tel: +33 1 30 62 50 00
Fax: +33 1 30 62 51 93

Malawi
danfoss@danfoss.co.za
Tel: +27 11 803 8390
Fax: +27 11 803 8244

Malaysia
MYSC.RA@danfoss.com
Tel: +60 3-7845 1608
Fax: +60 3-7845 1609

Mali
c_piriou@danfoss.fr
Tel: +33 1 30 62 50 00
Fax: +33 1 30 62 51 93

Malta
paul@enesave.com
Tel: +356 21467966
Fax: +356 21467966

Mexico
scdivision@danfoss.com
Tel: +52 (81) 8156 5683
Fax: +52 (81) 8156 5625

Morocco
danfoss@danfoss.fr
Tel: +33 1 30 62 50 00
Fax: +33 1 30 62 51 93

Mozambique
danfoss@danfoss.co.za
Tel: +27 11 803 8390
Fax: +27 11 803 8244

Namibia
Tel: +26 4 61 26 2876
Fax: +26 4 61 26 2894

Netherlands
Tel: +31 10 249 2000
Fax: +31 (10) 249 2001

New Caledonia
o_schenberg@danfoss.fr
Tel: +33 1 30 62 50 00
Fax: +33 1 30 62 51 93

Nicaragua
scdivision@danfossmt.com.mx
Tel: +52 81 8156 5683
Fax: +52 81 8156 5625

Niger
o_schenberg@danfoss.fr
Tel: +33 1 30 62 50 00
Fax: +33 1 30 62 51 93

Nigeria
n.dinesh@danimex.com
Tel: +234 1775 1137

Norway
danfoss@danfoss.no
Tel: +47 67 17 72 00
Fax: +47 67 13 68 50

Pakistan
info@khanbrothers.net
Tel: +92 21 452 6002/3/4
Fax: +92 21 454 5995

Panama
scdivision@danfossmt.com.
Tel: +52 81 8156 5683
Fax: +52 81 8156 5625

Paraguay
h.petersen@att.mail.com
Tel: +595 21 202615
Fax: +595 21 213819

Peru
Tel: +51 1 478 0808
Fax: +51 1 362 5191

Philippines
danfossinc@danfoss.com
Tel: +63 2 809 7130
Fax: +63 2 809 7271

Poland
info@danfoss.pl
Tel: +48 (22) 755 0700
Fax: +48 (22) 755 0701

Portugal
danfoss@danfoss.pt
Tel: +351 214 248 934
Fax: +351 214 172 466

Puerto Rico
scdivision@danfossmt.com.mx
Tel: +52 81 8156 5683
Fax: +52 81 8156 5625

Qatar
danfoss@emirates.net.ae
Tel: +971 4 88 72220
Fax: +971 4 88 72221

Réunion
o_schenberg@danfoss.fr
Tel: +33 1 30 62 50 00
Fax: +33 1 30 62 51 93

Romania
danfoss.ro@danfoss.com
Tel: +40 21 335 52 02
Fax: +40 21 335 55 59

Russian Federation
info@danfoss.ru
Tel: +7 495 792 57 57
Fax: +7 495 792 57 59

Rwanda
o_schenberg@danfoss.fr
Tel: +33 1 30 62 50 00
Fax: +33 1 30 62 51 93

Saudi Arabia
danfoss@emirates.net.ae
Tel: +971 4 88 72220
Fax: +971 4 88 72221

Senegal
o_schenberg@danfoss.fr
Tel: +33 1 30 62 50 00
Fax: +33 1 30 62 51 93

Serbia & Montenegro
danfoss.cs@danfoss.com
Tel: +381 11 313 0620
Fax: +381 11 313 0636

Seychelles
danfoss@danfoss.co.za
Tel: +27 11 803 8390
Fax: +27 11 803 8244

Sierra Leone
o_schenberg@danfoss.fr
Tel: +33 1 30 62 50 00
Fax: +33 1 30 62 51 93

Singapore
spore.refrigeration@danfoss.
Tel: +65 (6) 885 9788
Fax: +65 (6) 885 9799

Slovak Republic
danfoss.sk@danfoss.com
Tel: +421 (37) 6406280
Fax: +421 (37) 6406290

Slovenia
danfoss.si@danfoss.com
Tel: +386 1 518 6108
Fax: +386 1 507 25 18

South Africa
danfoss@danfoss.co.za
Tel: +27 11 803 8390
Fax: +27 11 803 8244

Spain
Tel: +34 91 658 66 88
Fax: +34 91 663 73 70

Sri Lanka
dhammi@eureka.lk
Tel: +94 115343190
Fax: +94 115343191

Swaziland
danfoss@danfoss.co.za
Tel: +27 11 803 8390
Fax: +27 11 803 8244

Sweden
danfoss@danfoss.se
Tel: +46 1325 8500
Fax: +46 1313 0181

Switzerland
e-mail@danfoss.ch
Tel: +41 (61)-906 11 11
Fax: +41 (61)-906 11 21

Syria
hafco@net.sy
Tel: +963 94 423 421
Fax: +963 11 212 94 67

Taiwan
office@twdanfoss.com.tw
Tel: +886 (0) 2 8226 3263
Fax: +886 (0) 2 8226 3269

Tajikistan
info@danfoss.ru
Tel: +7 095* 792 57 57
Fax: +7 095* 792 57 59

Tanzania
danfoss@danfoss.co.za
Tel: +27 11 803 8390
Fax: +27 11 803 8244

Thailand
stove@danfoss.com
Tel: +66 2 379 9800
Fax: +66 2 379 9801

Tunisia
o_schenberg@danfoss.fr
Tel: +33 1 30 62 50 00
Fax: +33 1 30 62 51 93

Turkey
danfoss@danfoss.com.tr
Tel: +90 212 356 6110
Fax: +90 212 356 6251

Turkmenistan
info@danfoss.ru
Tel: +7 095* 792 57 57
Fax: +7 095* 792 57 59

Ukraine
ua_postmaster@danfoss.com
Tel: +380 44 4618700
Fax: +380 44 4618707

United Arab Emirates
danfoss@emirates.net.ae
Tel: +971 4 88 72220
Fax: +971 4 88 72221

Uruguay
seler@netgate.com.uy
Tel: +598 2 601 5751
Fax: +598 2 601 5741

USA
namc@danfoss.com
Tel: +1 (815) 639-8600
Fax: +1 (815) 639-80002

Uzbekistan
info@danfoss.ru
Tel: +7 095* 792 57 57
Fax: +7 095* 792 57 59

Venezuela
pdy@danfoss.com
Tel: +58 241 832 4444
Fax: +58 241 832 8409

Vietnam
danfoss_vietnam@danfoss.com
Tel: +84 88 106 806 (5 lines)
Fax: +84 88 106 805

Yemen
danfoss@emirates.net.ae
Tel: +971 4 88 72220
Fax: +971 4 88 72221

Zambia
danfoss@danfoss.co.za
Tel: +27 11 803 8390
Fax: +27 11 803 8244

Zimbabwe
danfoss@danfoss.co.za
Tel: +27 11 803 8390
Fax: +27 11 803 8244



What VLT® is all about

Danfoss Drives is the world leader among dedicated drives providers – and still gaining market shares.

The Headquarter in Graasten, Denmark.



Dedicated to drives

Dedication has been a key word since 1968, when Danfoss introduced the world's first mass produced variable speed drive for AC motors – and named it VLT®.

Two thousand employees develop, manufacture, sell and service drives and softstarters in more than one hundred countries – and nothing but drives and softstarters.

Intelligent and innovative

Developers at Danfoss Drives have fully adopted modular principles in development as well as design, production and configuration. Tomorrow's features are developed in parallel using dedicated technology platforms. This allows the development of each element to take in parallel, at the same time reducing time to market and ensuring that customers always enjoy the benefits of the latest features.

Depend on the experts

We take responsibility for every element in our products. The fact that we develop and produce our own features, hardware, software, power modules, printed circuit boards, and accessories is your guarantee for reliable products.



Local backup – globally

VLT® motor controls are operating in applications all over the world and Danfoss Drives, experts are ready to support our customers with application advice and service wherever they may be.

Danfoss Drives experts only ever stop when the customer's drive problems are solved.