

ENGINEERING
TOMORROW

Danfoss

Fact Sheet | VACON® 3000 Drive Kit

Boost your **toughest applications**
with a unique **modular** approach

Definite purpose
**Medium-
voltage
drives**

Power rating

12-pulse DFE drives

AC drive type	Continuous rating (variable torque)		Low overload rating 110% (constant torque)		High overload rating 150% (constant torque)		Output frame size
	Continuous current I_{th} [A]	Continuous power [kVA]	Continuous current I_L [A]	Continuous power [kVA]	Continuous current I_H [A]	Continuous power [kVA]	
Nominal voltage 3300 V							
VACON3000-12-0425-03	425	2430	386	2209	283	1620	L20HLx3 (425-03)
VACON3000-12-0640-03	640	3660	582	3327	427	2440	L30HLx3 (640-03)
VACON3000-12-0820-03	820	4690	745	4264	547	3127	L20HLx6 (425-03)
VACON3000-12-1230-03	1230	7030	1118	6391	650	4680	L30HLx6 (640-03)
Nominal voltage 4160 V							
VACON3000-12-0340-04	340	2450	309	2227	227	1633	L20HLx3 (340-04)
VACON3000-12-0510-04	510	3670	464	3336	340	2447	L30HLx3 (510-04)
VACON3000-12-0650-04	650	4680	591	4255	433	3120	L20HLx6 (340-04)
VACON3000-12-0980-04	980	7060	891	6418	650	4680	L30HLx6 (510-04)

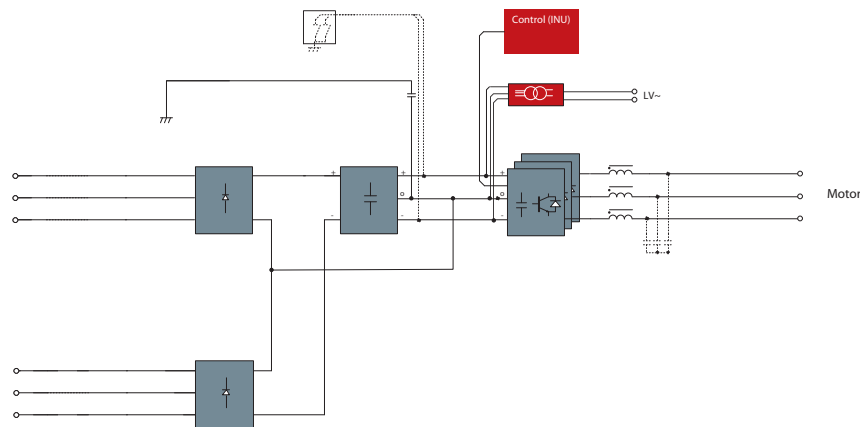

Active Front End drives

AC drive type	Continuous rating (variable torque)		Low overload rating 110% (constant torque)		High overload rating 150% (constant torque)		Output frame size
	Continuous current I_{th} [A]	Continuous power [kVA]	Continuous current I_L [A]	Continuous power [kVA]	Continuous current I_H [A]	Continuous power [kVA]	
Nominal voltage 3300 V							
VACON3000-4Q-0425-03	425	2430	386	2209	283	1620	L20HLx3 (425-03)
VACON3000-4Q-0640-03	640	3660	582	3327	427	2440	L30HLx3 (640-03)
VACON3000-4Q-0820-03	820	4690	745	4264	547	3127	L20HLx6 (425-03)
VACON3000-4Q-1230-03	1230	7030	1118	6391	650	4680	L30HLx6 (640-03)
Nominal voltage 4160 V							
VACON3000-4Q-0340-04	340	2450	309	2227	227	1633	L20HLx3 (340-04)
VACON3000-4Q-0510-04	510	3670	464	3336	340	2447	L30HLx3 (510-04)
VACON3000-4Q-0650-04	650	4680	591	4255	433	3120	L20HLx6 (340-04)
VACON3000-4Q-0980-04	980	7060	891	6418	650	4680	L30HLx6 (510-04)

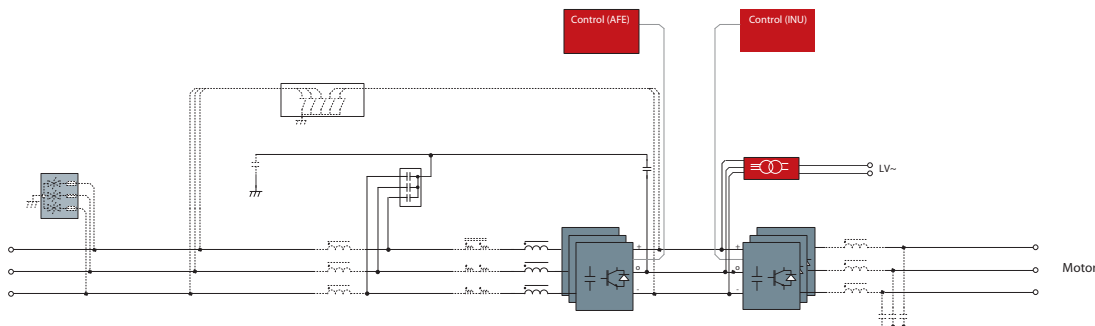

Options

VACON® 3000 Drive Kit

Factory option	Description	Option slot				AC drive
		B	C	D	E	VACON® 3000
I/O options						
+HRGR	Standard I/O board: 2 x AI, 6 x DI, 1 x AO, 10 V _{ref} , 24 V _{in} , 2 x 24 V _{out} , RS485, 3 x RO	■				■
+S_B1	6 x DI / DO, programmable		■	■	■	■
+S_B4	1 x AI, 2 x AO (isolated)		■	■	■	■
+S_B5	3 x RO		■	■	■	■
+S_B9	1 x RO, 5 x DI (42-240 V AC)		■	■	■	■
+S_BF	1 x AO, 1 x DO, 1 x RO		■	■	■	■
+S_BH	3 x Temp sensor inputs (PT100, PT1000, KTY84-130, KTY84-150, KTY84-131, NI1000)		■	■	■	■
Communications						
+S_E3	PROFIBUS DPV1			■	■	■
+S_E5	PROFIBUS DPV1 (D9)			■	■	■
+S_E6	CANopen			■	■	■
+S_E7	DeviceNet			■	■	■
+S_EC	EtherCAT			■	■	■
+S_E9	Dual Port Ethernet			■	■	■
Power dependent options						
+PICM	Input common mode filter (<i>for AFE variants only</i>)					■
+QTVS	Transient suppressor on input					■
+PODU	Output dU/dt filter					■
+POSI	Output sine filter					■
+PHSI	High source impedance (<i>for AFE variants only</i>)					■
+DBCUC	Brake chopper for dynamic braking (<i>excl. resistor</i>)					■
Auxiliary units options						
+QAIT	Isolated auxiliary transformer for power section					■
+PRAC	Rack for power modules assembly					■
+QGWSW	Grounding switch					■

VACON® 3000 Drive Kit

Standard factory option	Description	AC drive
		VACON® 3000
Default for all VACON® 3000 drives		
+HMGR	Graphical keypad	■
+FBIE	Industrial Ethernet protocols: PROFINET IO and EtherNet/IP™ (<i>software option onboard</i>)	■
+SRBT	Real time clock battery	■
+DPAP	Printed manuals	■
+DLUS	English (USA)	■
+WT01	Extended warranty: 18 months from shipment or 12 months of commissioning	■

Technical data

Topology	3-level neutral point clamped (NPC)	HV-IGBT
Inverter capacity	L20-HLx3	425 A, 3300 V, 2.4 MVA* 340 A, 4160 V, 2.4 MVA*
	L30-HLx3	640 A, 3300 V, 3.7 MVA* 510 A, 4160 V, 3.7 MVA* * Higher power capacities achieved by paralleling inverters
Input voltage		3300 V, 3 phases ± 10%
		4160 V, 3 phases ± 10%
Input frequency		50 Hz ± 5% (3300 V) or 60 Hz ± 5% (4160 V)
Rectifier	Active Front End	AFE
	Diode Front End	12 and 24-pulse DFE
Input current THD	AFE	< 5%
	12-pulse DFE	Typically 15%
	24-pulse DFE	Typically 8%
Power factor		>0.95
Output voltage levels		3 (5 phase-to-phase)
Output frequency		0-120 Hz
Accel./Decel. time		0.1-3600 s
Grounding		Resistance grounded neutral point, high or low resistance grounding system of electricity supply, if no dedicated transformer is installed. For operation in an IT network without a dedicated transformer, speak to Danfoss Drives.
Switching frequency		AFE: 1050 Hz (50 Hz) and 1260 Hz (60 Hz) INU: 900 Hz synchronous PWM
Motor control method	Asynchronous (induction) motor	U/f control Open loop control Indirect closed loop control Closed loop control
Communication		AI/O, DI/O, fieldbuses (e.g. PROFIBUS DPV1, DeviceNet), industrial Ethernet protocols (PROFINET IO and EtherNet IP™), VACON® PC tool
Main protective functions		Torque and power limit, current limit, overcurrent, overvoltage, undervoltage, loss of auxiliary power, loss of communication, ground fault detection
Efficiency	AFE + INU	>98%
	DFE + INU	>98.5%, excluding the input transformer
Temperature	Operational (<i>ambient</i>)	0 °C to +45 °C (+30 °F to +113 °F)
	Storage (<i>ambient</i>)	-40 °C to +70 °C (-40 °F to +158 °F); No liquid in heat sink under 0 °C (+32 °F)
	Power module inlet cooling liquid	0 °C to +43 °C (+32 °F to +109 °F). Lowest allowed cooling liquid temperature 2 °C (3.6 °F) above the dew point.
Relative humidity		< 95 % RH, non-condensation, non-corrosive
Cooling	Power module (<i>phase modules, rectifiers</i>)	Liquid cooled
	Chokes	Hybrid cooling (<i>forced air cooled with air-to-liquid heat exchanger</i>)
Standards		IEC**, cUL**, marine standards**

** certification pending



L20-HL



L30-HL



Control unit



Pre-charge



Choke

VLT® | VAGON®

Danfoss can accept no responsibility for possible errors in catalogues, brochures and other printed material. Danfoss reserves the right to alter its products without notice. This also applies to products already on order provided that such alterations can be made without consequential changes being necessary in specifications already agreed. All trademarks in this material are property of the respective companies. Danfoss and the Danfoss logotype are trademarks of Danfoss A/S. All rights reserved.