



中国国家强制性产品认证证书

证书编号：2016010304858669

委托人名称、地址

丹佛斯自动控制管理（上海）有限公司
中国（上海）自由贸易试验区德堡路376号1幢二层205部位

生产者（制造商）名称、地址

AuCom Electronics Limited
123 Wrights Road, Christchurch, New Zealand

生产企业名称、地址

AuCom Electronics Limited
123 Wrights Road, Christchurch, New Zealand

产品名称和系列、规格、型号

软起动器

MCD5-0245B, MCD5-0331B, MCD5-0396B, MCD5-0469B, MCD5-0525B, MCD5-0632B, MCD5-0744B,
MCD5-0826B, MCD5-0961B: Ui: 600V (phase to earth), 690V (phase to phase); Ue: AC200V-440V or
AC380V-690V (690V on earthed star supply system only) Ith: 255A, 350A, 425A, 500A, 580A, 700A, 820A, 920A
and 1000A; Ie: 255A, 350A, 425A, 500A, 580A, 700A, 820A, 920A and 1000A;
Pe: 132kW, 160kW, 185kW, 220kW, 300kW, 315kW, 355kW, 400kW, 500kW; 使用类别: AC-53b; 极数: 3P; 型
号解释见附件

产品标准和技术要求

GB/T 14048.6-2016

上述产品符合强制性产品认证实施规则 CNCA-C03-02:2014 的要求，
特发此证。

发证日期：2019年07月15日 有效期至：2022年03月01日
证书有效期内本证书的有效性依据发证机构的定期监督获得保持。

本证书为变更证书，证书首次颁发日期：2016年04月18日

本证书的相关信息可通过国家认监委网站 www.cnca.gov.cn 查询



主任：

陆梅



中国质量认证中心



CERTIFICATE FOR CHINA COMPULSORY PRODUCT CERTIFICATION

CERTIFICATE NO.: 2016010304858669

NAME AND ADDRESS OF THE APPLICANT

Danfoss (shanghai)Automatic Control Co.,Ltd
NO.23 factory, No. 360 Basheng Road, Wai Gao Qiao Free Trade Zone Shanghai

NAME AND ADDRESS OF THE MANUFACTURER

AuCom Electronics Limited
123 Wrights Road, Christchurch, New Zealand

NAME AND ADDRESS OF THE FACTORY

AuCom Electronics Limited
123 Wrights Road, Christchurch, New Zealand

PRODUCT NAME, MODEL AND SPECIFICATION

Soft Starter

MCD5-0744B, MCD5-0826B, MCD5-0961B: Ui: 600V (phase to earth), 690V (phase to phase); Ue: AC200V-440V or AC380V-690V (690V on earthed star supply system only) Ith: 255A, 350A, 425A, 500A, 580A, 700A, 820A, 920A and 1000A; Ie: 255A, 350A, 425A, 500A, 580A, 700A, 820A, 920A and 1000A; Pe: 132kW, 160kW, 185kW, 220kW, 300kW, 315kW, 355kW, 400kW, 500kW; Utilization Category: AC-53b; Poles: 3P

THE STANDARDS AND TECHNICAL REQUIREMENTS FOR THE PRODUCTS

GB/T 14048.6-2016

This is to certify that the above mentioned product(s) complies with the requirements of implementation rules for compulsory certification (REFNO.CNCA-C03-02:2014).

Valid from: Jul.15,2019

Valid until: Mar.01,2022

The validity of the certificate is subject to positive result of the regular follow up inspection by issuing certification body until the expiry date.

Date of original issued: Apr.18,2016

The certificate information is available through CNCA's website: www.cnca.gov.cn



President:

Lu Mei



CHINA QUALITY CERTIFICATION CENTRE



中国国家强制性产品认证证书

附录

第 1 页 共 1 页

证书编号: 2016010304858669

纸号: 2352219

型号解释:

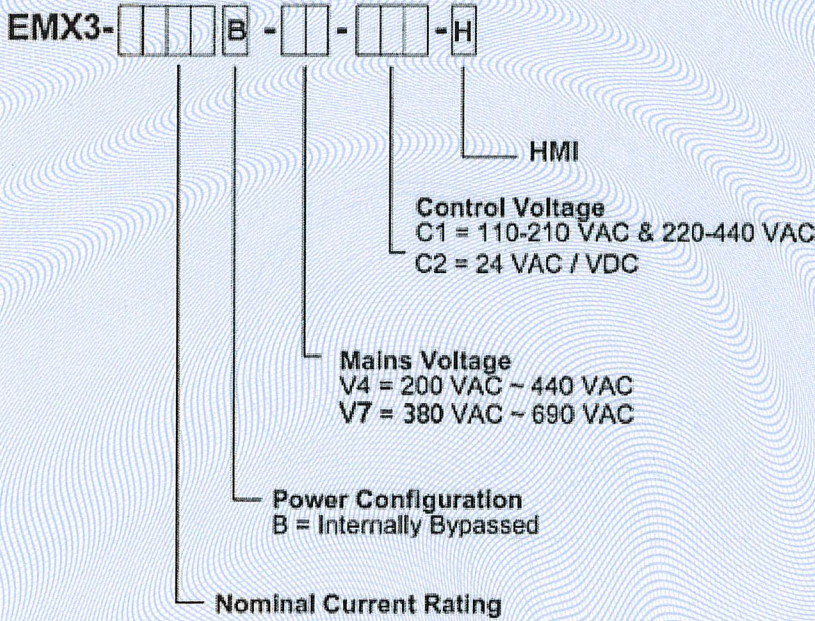

注: 此附录与证书同时使用时有效。



主任: 陆梅



中国质量认证中心