



# Selection Guide 1.1 kW – 400 kW VLT® HVAC Drive FC 102

98%

Energy efficiency

Save energy and money with up to 98% efficient VLT® drives

VLT®  
HVAC Drive



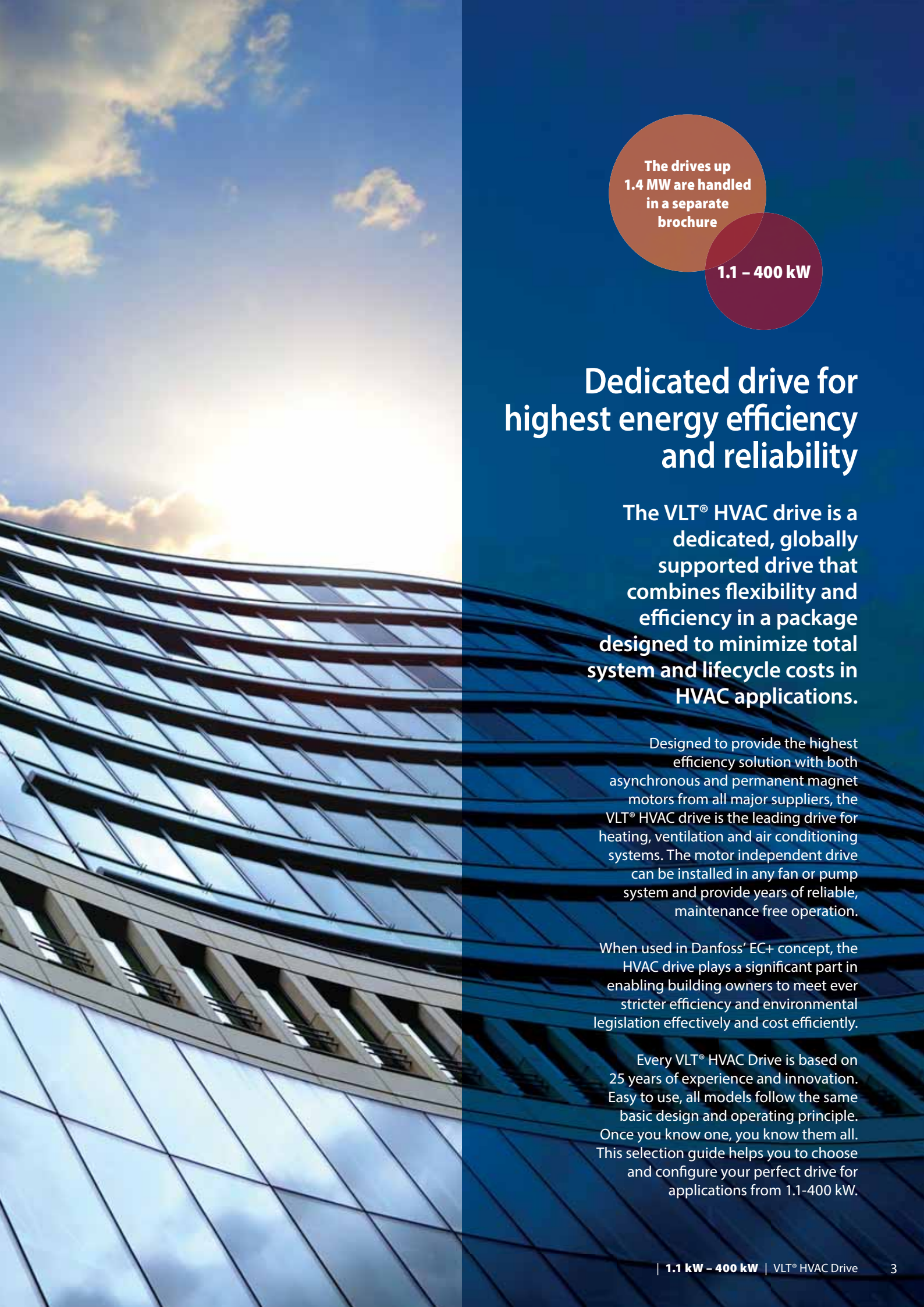

The drives up  
1.4 MW are handled  
in a separate  
brochure

1.1 – 400 kW

## Dedicated drive for highest energy efficiency and reliability

The VLT® HVAC drive is a dedicated, globally supported drive that combines flexibility and efficiency in a package designed to minimize total system and lifecycle costs in HVAC applications.

Designed to provide the highest efficiency solution with both asynchronous and permanent magnet motors from all major suppliers, the VLT® HVAC drive is the leading drive for heating, ventilation and air conditioning systems. The motor independent drive can be installed in any fan or pump system and provide years of reliable, maintenance free operation.

When used in Danfoss' EC+ concept, the HVAC drive plays a significant part in enabling building owners to meet ever stricter efficiency and environmental legislation effectively and cost efficiently.

Every VLT® HVAC Drive is based on 25 years of experience and innovation. Easy to use, all models follow the same basic design and operating principle. Once you know one, you know them all. This selection guide helps you to choose and configure your perfect drive for applications from 1.1-400 kW.



**Up to 50° C ambient temperature without derating**



### **GLOBAL REACH**

*Danfoss' efficient global logistics setup makes it possible to ship VLT® drives quickly to any destination.*

*Danfoss' global support organization is geared to react swiftly to resolve issues to help you reduce downtime. In the event of issues Danfoss' global hotline helps you find the right solution quickly and efficiently.*

*In order to provide fast support in major industrial areas Danfoss is also present with highly trained, dedicated professionals. Based close to chemical hotspots, marine hubs and major industrial areas around the world, Danfoss experts are ready to provide fast access to drive and application expertise.*

### **TRAINING BASED ON EXPERIENCE**

*Keep up to date on trends, methods and features that save additional energy or offer new technical opportunities to increase your product quality or decrease the downtime of your plant.*

*Receive the same quality training anywhere in the world with Danfoss-developed material and trainers. Training can take place at one of Danfoss' facilities or directly at the customer's own facility. Teaching is conducted by local trainers who have broad experience in the many conditions that may affect performance, so you get the most out of your Danfoss solution.*

*Additionally, the new online platform Danfoss Learning offers you the opportunity to extend your knowledge in small and compact lessons up to extensive training courses, when and wherever you want.*

*Read more at [learning.danfoss.com](http://learning.danfoss.com)*

# Flexible, modular and adaptable

## Built to last

**The VLT® HVAC Drive is built on a flexible, modular design concept to provide an extraordinarily versatile motor control solution. Equipped with a wide range of HVAC features owners can achieve optimal fan and pump control, higher quality output and reduce costs related to spare parts and service, and much more.**

### Built-in EMC filters

VLT® HVAC Drive units are equipped with integrated DC link chokes and EMC filters as standard features. This enables them to reduce grid pollution and eliminate the cost and effort of fitting external EMC components and related wiring.

### Reduce costs with compact drives

A compact design and efficient heat management enable the drives to take up less space in control rooms and panels in all kinds of environments. Especially impressive is the 315 kW, 400 V version, which is among the smallest in its power class on the market today, and is available in an IP 54 enclosure.

Compact dimensions are also an advantage in applications where drive space is restricted. This makes it possible for designers to develop smaller applications without being forced to compromise on protection and grid quality. For example, the D frame versions of the VLT® HVAC Drive FC 102 from 110-400 kW are 25-68% smaller than equivalent drives.

The IP 20 version is optimized for cabinet mounting and features covered power terminals to prevent accidental

contact. The unit can also be ordered with optional fuses or circuit breakers in the same package size. Control and power cables are fed in separately at the bottom.

The frequency converters combine a flexible system architecture, which allows them to be adapted to specific applications, with a uniform user interface across all power classes. This allows you to adapt the drive to the exact needs of your specific application. As a result project work and costs are subsequently reduced. The easy to use interface reduces training requirements. The integrated SmartStart guides users quickly and efficiently through the setup process, which results in fewer faults due to configuration and parameterization errors.

### Freedom to design efficient systems

HVAC drives are built on a flexible system architecture, which allows them to be adapted to specific applications to provide maximum system efficiency.

Available in a performance range from 1.1 kW to 1.4 MW the FC 102 series can control nearly all standard industrial motor technologies, including permanent magnet motors, copper rotor motors and direct line PM.

The frequency converter is designed to work with all common supply voltages: 200, 380-480 V, 525-600 V and 690 V.

As a result, system designers, OEMs and end users can connect the drive to their chosen motor and reduce project costs with a solution that performs to the highest standards.



### VLT® PLATFORM HIGHLIGHTS

- *Versatile, flexible, configurable*
- *EMC filters integrated as standard*
- *Asynchronous & PM motor control*
- *9 fieldbuses supported*
- *Up to 1.4 MW in common voltages*
- *Unique user interface*
- *Globally supported*

# Size and protection class

## The perfect fit for your application

All Danfoss VLT® frequency converters follow the same design principle for fast, flexible and fault-free installation and efficient cooling.

VLT® HVAC Drives are available in a broad range of enclosures sizes and protection ratings from IP 20 to IP 66 to enable easy installation in all environments: mounted in panels, switch rooms or as stand-alone units for heating, ventilation and air conditioning.

### Cost saving heat management

In VLT® HVAC Drives the cooling air and the internal electronics is separated, protecting electronics

from contaminants. At the same time it removes heat efficiently which helps to prolong product life, increase the overall availability of the system and reduce faults related to high temperatures.

For example, by exhausting heat directly outside it is possible to reduce the size of the cooling system in the panel or switch room. This can be achieved with Danfoss' panel through cooling system or the extremely

efficient back channel cooling concept, that also allows to conduct the heat into the outside of the control room. Both methods make it possible to reduce the initial cost of the panel or switch room.

In daily use the benefits are equally clear as the energy consumption related to cooling can be reduced significantly. This means that designers can reduce the size of the air conditioning system, or even eliminate it entirely.

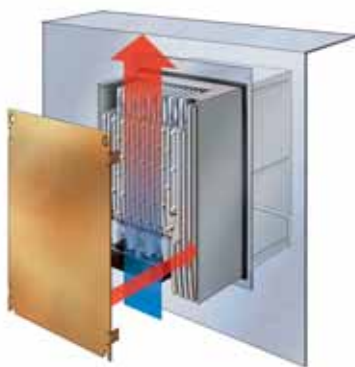

### PANEL THROUGH COOLING

An accessory mounting kit for small and mid-range drives enables heat losses to be directed directly outside the panel room.



### BACK CHANNEL COOLING

By directing air through a rear cooling channel up to 85-90% of the drive's heat loss is removed directly outside the installation room.



### NO AIR OVER ELECTRONICS

Complete separation between cooling air and the internal electronics ensure efficient cooling.

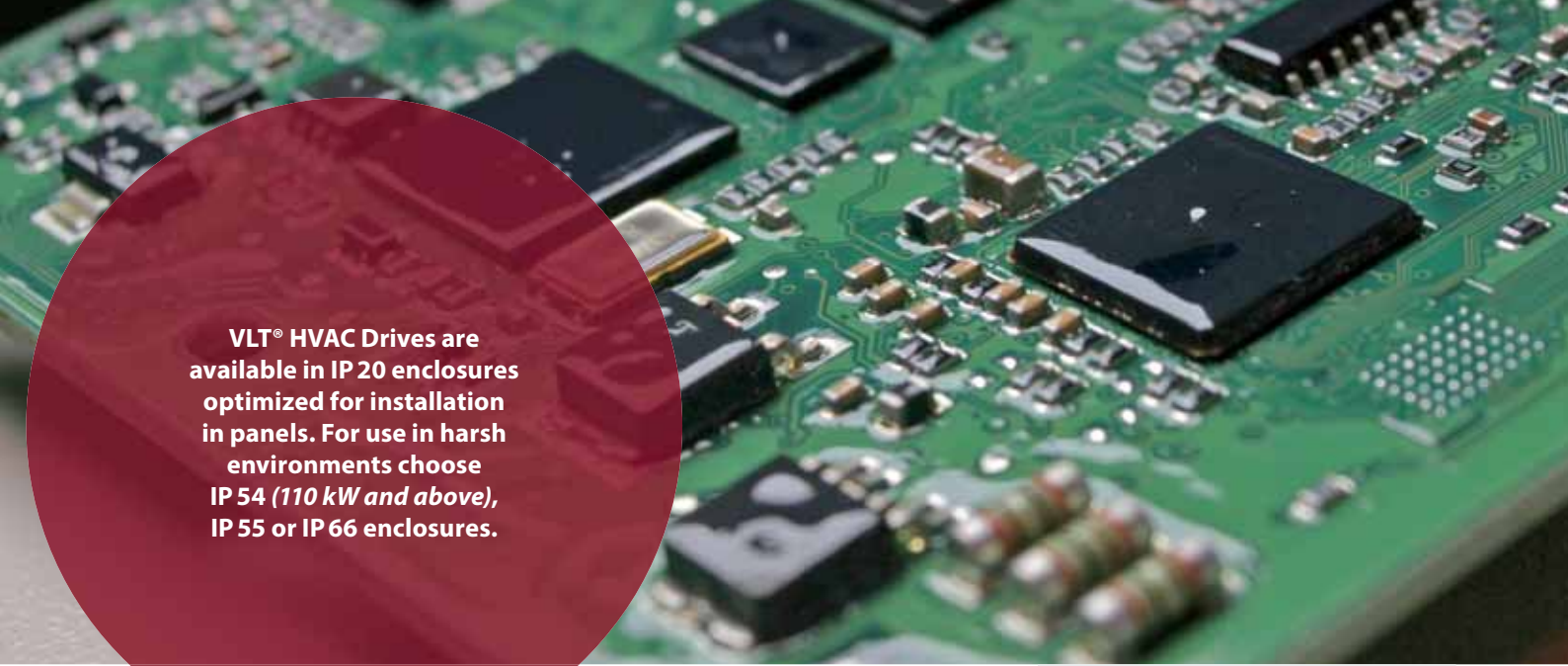

VLT® HVAC Drives are available in IP 20 enclosures optimized for installation in panels. For use in harsh environments choose IP 54 (110 kW and above), IP 55 or IP 66 enclosures.

### Coated circuit boards

The VLT® HVAC Drive is as standard conforming to class 3C2 (IEC 60721-3-3). If used in especially harsh conditions it is possible to order a special coating that complies with class 3C3.

### Ruggedized for extra protection

The VLT® HVAC Drive is available in a 'ruggedized' version, that ensures that components remain firmly in place in environments characterized by high degrees of vibration such as Marine and mobile equipment.

### RETROFITTING. FAST UPGRADE TO NEWEST TECHNOLOGY PLATFORM



*As technologies evolve and newer, smaller and more efficient models replace old drives, it is important to Danfoss that you can change and upgrade as easily as possible. Minimize downtime in your production and update your installation in a few minutes with prepared tools from Danfoss. With a Danfoss conversion kit it is easy and fast to prepare your application for the future:*

- Mechanical adaptation
- Electric adaptation
- Parameter adaptation

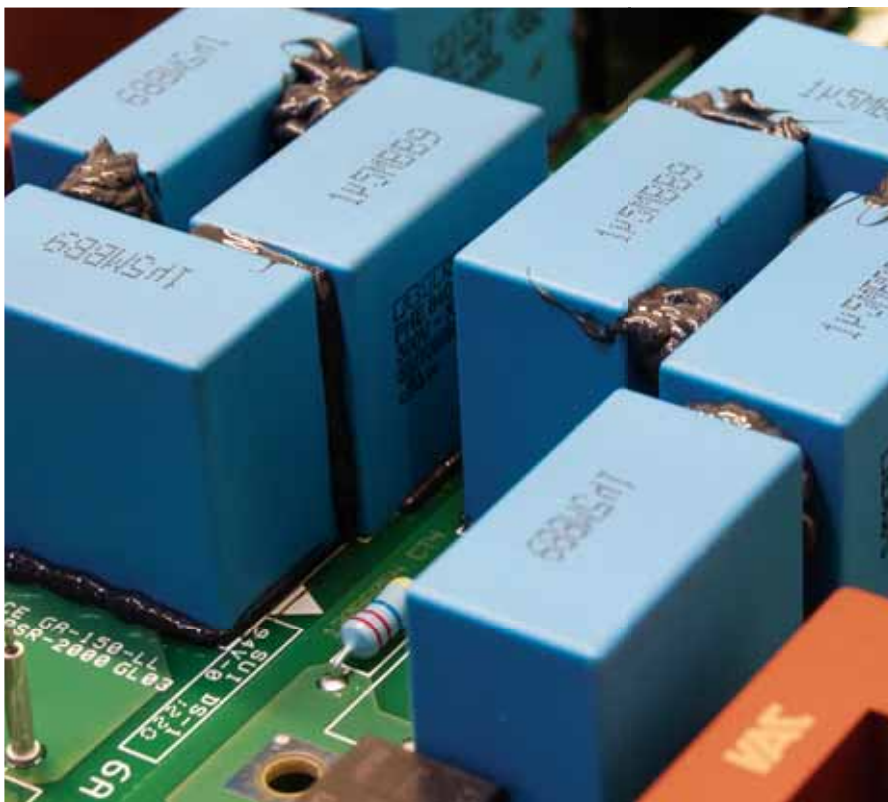



**Danfoss  
VLT® HVAC Drives  
are equipped with DC  
chokes that reduce  
mains interference  
to a THDi of 40%.**

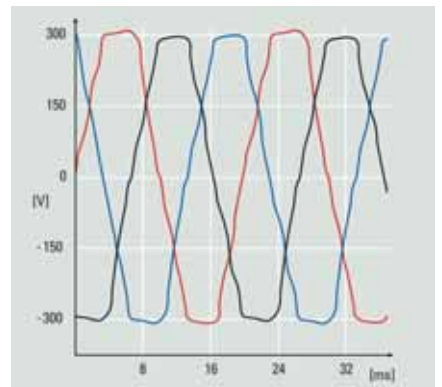

**HARMONIC DISTORTION**  
*Electrical interference reduces efficiency  
and risks harming equipment.*

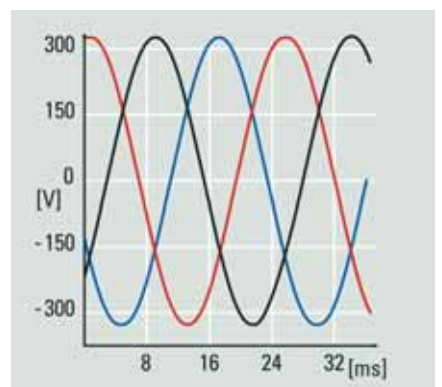

**OPTIMISED HARMONIC  
PERFORMANCE**  
*Efficient harmonic mitigation protects  
electronics and increases efficiency.*





# Optimize performance and grid protection

## Built-in protection as standard

The VLT® HVAC Drive FC 102 contains all modules necessary for compliance with EMC standards.

A built-in scalable RFI filter minimizes electromagnetic interference. Integrated DC chokes reduce harmonic distortion in the mains network, which increases the lifetime of the DC link capacitors and therefore the drive system's overall efficiency.

The solutions save cabinet space, as they are integrated in the drive from the factory. Efficient EMC mitigation also enables the use of cables with smaller cross-sections, which again reduces installation costs.

## Expand grid protection with filter solutions

If needed, Danfoss' wide range of solutions for harmonic mitigation can provide additional protection, such as the

- VLT® Advanced Harmonic Filter AHF
- VLT® Advanced Active Filter AAF
- VLT® Low Harmonic Drives
- 12-pulse VLT® drives

Provide motor protection with:

- VLT® Sine Wave Filter
- VLT® dU/dt Filter

With this solutions you may achieve optimum performance for your application, even in weak or unstable grids.

## Use motor cables up to 300 m

The design of the VLT® HVAC Drive makes it a perfect choice in applications that require long motor cables. Without needing additional components the drive provides trouble free operation with cable lengths of up to 150 m screened or 300 m unscreened. This allows the drive to be installed in a central control room a distance away from the application without affecting motor performance.



EMC Standards		Conducted emission		
Standards and requirements	EN 55011 Facility operators must comply with EN 55011	Class B Housing and light industries	Class A Group 1 Industrial environment	Class A Group 2 Industrial environment
	EN/IEC 61800-3 Converter manufacturers must conform to EN 61800-3	Category C1 First environment, home and office	Category C2 First environment, home and office	Category C3 Second environment
FC 102 compliance <sup>1)</sup>		■	■	■

For further details see the VLT® HVAC Drive Design Guide  
<sup>1)</sup> Compliance to mentioned EMC classes depends on the selected filter



# Increase safety

## Fire override mode

Activating the function "Fire-mode" within the VLT® drive ensures secure and continued operation within applications such as stair-well pressurisation, car park exhaust fans, smoke exhaust and essential service functions.

## Drive bypass

If a drive bypass is available the VLT® HVAC Drive will not only sacrifice itself; it will also bypass itself and connect the motor directly to mains. As a result fan functionality will be maintained after the drive fails, as long as there is power and the motor is functioning. *(only available in the USA)*

## Protect applications and operators

The VLT® HVAC Drive FC 102 is able to provide the STO (Safe Torque Off) function in compliance with ISO 13849-1 PL d and SIL 2, according to IEC 61508/IEC 62061. In high demand

applications this can be expanded with the VLT® Safe Option MCB 140, an external module that provides functions such as Safe Stop 1 (SS1),

Safely Limited Speed (SLS) and Safe Maximum Speed (SMS), control of external contactors and safety door monitoring and unlocking.

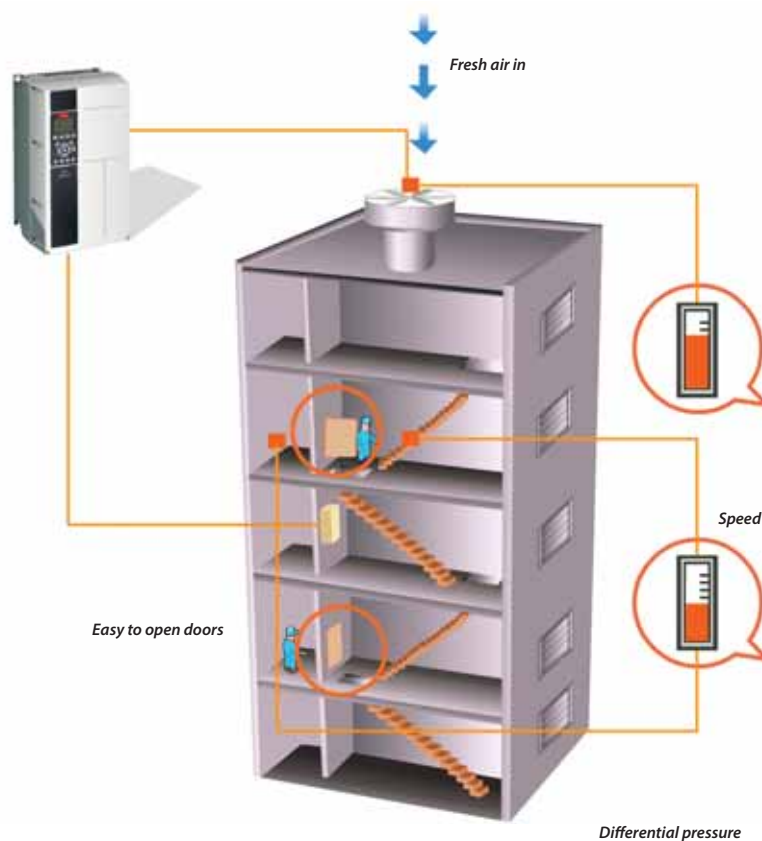



# Nine fieldbuses supported

## Increase productivity

With the wide range of fieldbus options the VLT® HVAC Drive can be easily connected to the fieldbus system of your choice. This makes the HVAC Drive a future-ready solution that can easily be expanded and updated if your needs change.

Danfoss fieldbus options can also be installed as a plug-and-play solution at a later stage, if the production layout demands a new communication platform. This way, you can be confident that you can optimize your plant without being forced to replace your existing drive system.

See the complete list of fieldbuses on page 24.

## BACnet Change of Value (COV)

The standard, passive, BACnet protocol that is embedded in every HVAC drive, can be expanded with the VLT® BACnet Option MCA 109 option.

This add-on enables the drive to support COV. As a result the drive will only communicate if pre-defined set-points are exceeded.

By effectively optimizing communication, the MCA 109 reduces the load on the fieldbus enabling more efficient building management.





# Energy documentation

**VLT® Energy Box software is the most modern and advanced energy calculation tool available.**

It allows energy consumption calculations and comparisons of HVAC fans, pumps and cooling tower applications driven by Danfoss drives and alternative methods of flow control.

The program compares the total operational costs of various traditional systems to operation of the same systems with a VLT® HVAC Drive.

With this program it is easy to evaluate the savings by comparing a VLT® HVAC Drive over other types of capacity control systems in both new installations as well as retrofit situations.

## Complete financial analysis

VLT® Energy Box provides a complete financial analysis including:

- Initial cost for the drive system and the alternative system
- Installation and hardware costs
- Annual maintenance costs and any utility company incentives for energy conservation products
- Payback time and accumulated savings
- Upload of actual energy consumption (kWh) and duty cycle from the VLT® HVAC Drive

VLT® Energy Box makes it possible to capture actual energy data from the drives and monitor energy consumption and overall system efficiency.

## Energy audit

The VLT® HVAC Drive coupled with Energy Box software enables the package to be used as the Energy Audit equipment for both the estimation and validation of savings.

VLT® HVAC Drive can be interrogated remotely for full energy data, making it easy to monitor your energy savings and return on investment. Monitoring via fieldbus often makes energy meters omissible.

**Download VLT® Energy Box**  
[www.danfoss.com/energybox](http://www.danfoss.com/energybox)

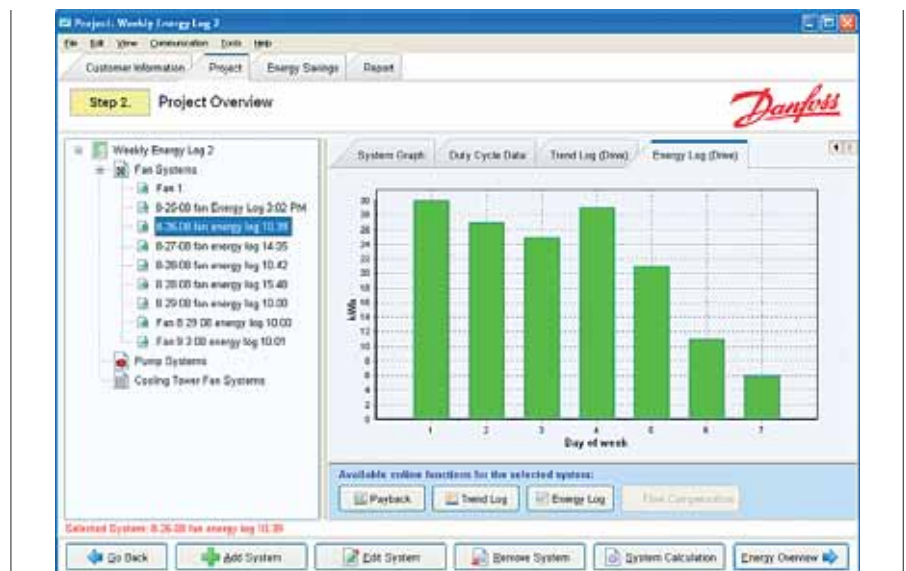



## Software tools

### Easy engineering and setup with VLT® Motion Control Tool MCT 10

In addition to operating the drive via LCP (local control panel), VLT® drives can also be configured and monitored with Danfoss own PC software. This provides plant managers with a comprehensive overview of the system at any point in time, adding a new level of flexibility in configuration, monitoring and troubleshooting.

MCT 10 is a windows based engineering tool with a clearly structured interface that provides an instant overview of all the drives in a system of any size. The software runs under Windows and enables data exchange over a traditional RS485 interface, fieldbus (Profibus, Ethernet, etc.) or via USB.

Parameter configuration is possible both online on a connected drive and offline in the tool itself. Additional documentation, such as electrical diagrams or operating manuals, can be embedded in MCT 10. This reduces the risk of incorrect configuration while offering fast access to troubleshooting.

### Analyse harmonic distortion with VLT® Harmonic Calculation Software HCS

This is an advanced simulation program that makes calculating harmonic distortion in your mains network fast and easy. It is the ideal solution both if you are planning to extend your

existing plant or installation or if you are planning a new installation from scratch.

The user-friendly interface allows you to configure the mains environment as desired and returns simulation results, which you can use to optimize your network.

Contact your local Danfoss sales office or visit our website for more information or visit directly at [www.danfoss-hcs.com](http://www.danfoss-hcs.com)

### VLT® Motion Control Tool MCT 31 Harmonics Calculation Software

VLT® MCT 31 calculates system harmonic distortion for both Danfoss and non-Danfoss drives. It is also able to calculate the effects of using various additional harmonic reduction

measures, including Danfoss harmonic filters.

With VLT® Motion Control Tool MCT 31, you can determine whether harmonics will be an issue in your installation, and if so, what strategies will be most cost-effective in addressing the problem.

VLT® Motion Control Tool MCT 31 features include:

- Short circuit current ratings can be used instead of transformer size and impedance when transformer data is unknown
- Project oriented for simplified calculations on several transformers
- Easy to compare different harmonic solutions within the same project
- Supports current Danfoss product line as well as legacy drive models

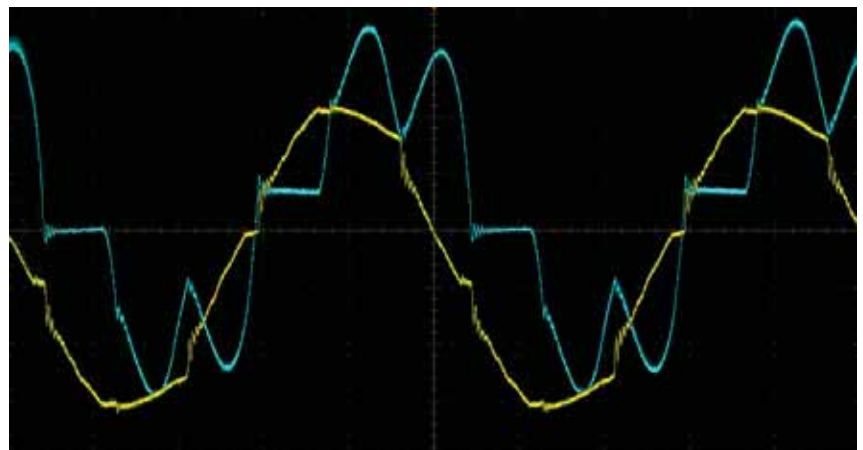



## Intuitive setup with graphical interface



The VLT® HVAC Drive features a user-friendly, hot pluggable local control panel (LCP) for easy setup and parameter configuration.

After choosing language navigate through setup parameters individually. Alternatively, use a pre-defined quick menu or a SmartStart guide for application specific setup.

The LCP can be detached and used to copy settings to other HVAC Drives in the system. It can also be mounted remotely on a control panel fascia. This enables the user to take full advantage of the LCP, eliminating the need for additional switches and instrumentation.

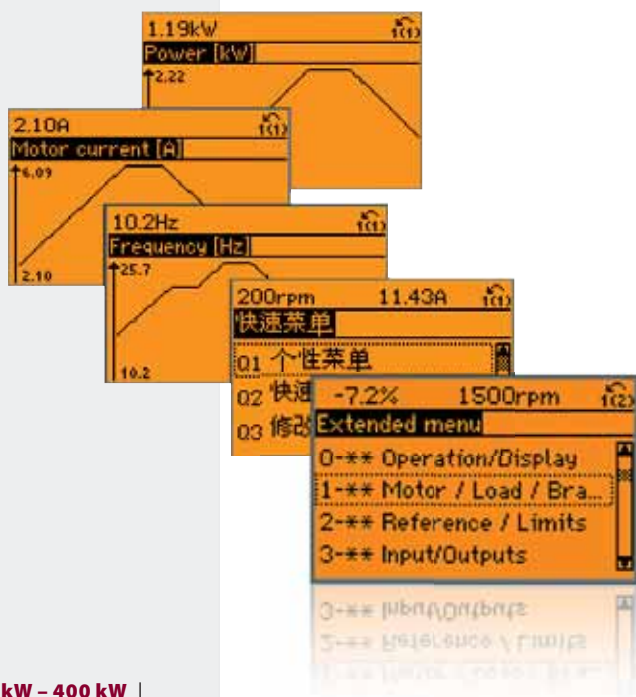



# Save commissioning time with SmartStart

SmartStart is a time-saving drive setup wizard that guides you through a series of easy steps to configure your drive. The wizard can be accessed with the drive's graphical control panel at the first power up of the drive or after a factory reset.

## Uses HVAC language

Using HVAC language, SmartStart asks you enter motor information and the application profile. The drive then calculates the optimal values to ensure reliable and energy efficient operation. When used with permanent magnet motors, which motor data may be based on a different value than 1000 RPM, SmartStart automatically recalculates the values to 1000 RPM.

## Intelligent optimization

SmartStart also asks if you want to apply the intelligent VLT features Automatic Motor Adaptation and Automatic Energy Optimization, enabling even more efficient motor control.

SmartStart is deactivated when the drive is programmed via fieldbus and after a timeout.

*NOTE: SmartStart is only accessible with the graphical control panel.*

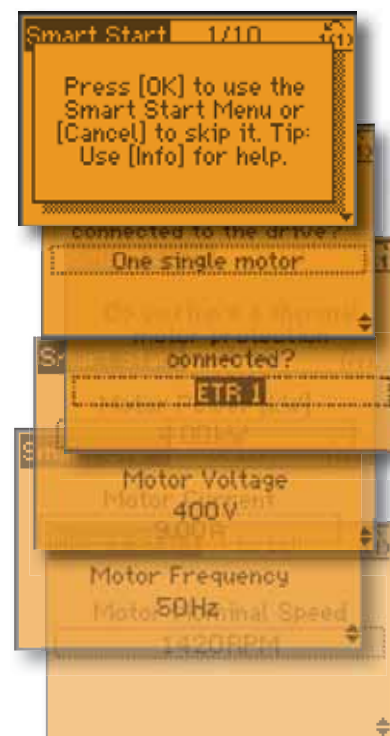



### ***Intelligent AHU functions***

*The ability to handle logical rules and inputs from sensors, real-time functionality, and time-related actions enables the HVAC Drive to control a wide range of functions:*

- *Weekend and working day operations*
- *Cascaded P-PI for temperature control*
- *Multi-zone "3" control*
- *Flow balancing between fresh and outlet air*
- *Belt monitoring*



# Dedicated fan features

The VLT® HVAC Drive offers a wide range of built-in and expandable functions that increase comfort and safety while reducing energy consumption.

## Velocity to flow conversion

The VLT® HVAC Drive is able to convert velocity pressure sensor values into flow values. This provides operators with the opportunity to set the drive up to provide a fixed flow or fixed differential flow. Regardless of method, the advantages are the same, as energy consumption is optimised while improving comfort. An added benefit is that this built-in setting eliminates the need for a flow sensor.

## Fire override mode

This safety feature prevents the drive from stopping to protect itself. Instead it will continue vital fan operation regardless of control signals, warnings or alarms.

## Extend BMS capacity

Easy integration into building management systems provides managers with detailed information about the current state of the infrastructure in the building. By integrating the drive into the building management network, all the I/O points in the drive are available as remote I/O to extend the capacity of the BMS.

For example: by installing room temperature sensors (PT100/PT 1000) and monitoring them with the VLT® Sensor Input Card, the motor is protected from overheating in the bearings and windings. Monitoring of sensor temperature is either visible as a readout on the display or via fieldbus.

## Resonance monitoring

Avoid unwanted noise by setting the drive to avoid the frequency bands that cause fans to create resonances. Not only does this increase comfort, it also reduces wear on the equipment.

## Stairwell pressurisation

If there is a fire, the VLT HVAC Drive will continue to control the motor, even beyond its standard shutoff parameters. By maintaining a higher level of air in the stairwells than in other parts of the building, fire escapes remain smoke free.

## Smart logic reduces costs

The drive's built-in Smart Logic Controller and four auto-tuning PID controllers can control air handling functions with fans, valves and dampers. This reduces DDC tasks in the building management system and frees valuable data points for other use.



## Mains switch

The mains switch is a safety feature that makes it possible to cut off the drive from the mains supply. As a result maintenance and cleaning is both easy and safe. The mains switch option also reduces assembly costs.



# Dedicated pump features

The VLT® HVAC Drive is developed in close cooperation with OEMs, contractors, and manufacturers around the world. Each drive contains a wide range of built-in, dedicated features save energy in pump applications.

## Embedded pump controller

The Pump Cascade Controller distributes operation hours evenly across all pumps. Wear and tear on individual pumps is therefore reduced to a minimum, extending their lifetime expectancy and reliability considerably. Vital water supply

If a pipe leaks or breaks, the HVAC Drive can reduce the motor speed to prevent overload, while continuing to supply water a lower speed.

## Sleep mode

In situations with low or now flow, the drive enters sleep mode to conserve energy. When the pressure falls below the pre-defined setpoint, the drive starts automatically. Compared to continuous operation this method reduces energy costs and equipment wear and tear, extending the lifetime of the application.

## 1. Dry Pump Protection and End of Curve

If the pump runs without creating the desired pressure, the drive sets off an alarm or performs another pre-programmed action. This happens for example when a well runs dry or a pipe leaks.

## 2. Auto tuning of PI controllers

Auto tuning enables the drive to monitor how the system reacts to corrections made by the drive constantly. The drive learns from it and calculates the P and I values, so precise and stable operation is restored quickly.

## 3. Flow compensation

A pressure sensor mounted close to the fan or pump provides a reference point that enables pressure to be kept constant at the discharge end of the system. The

drive constantly adjusts the pressure reference to follow the system curve. This method both saves energy and reduces installation costs.

## 4. No/low flow

During operation, a pump normally consumes more power the faster it runs. In situations where the pump runs fast, but is not fully loaded, and does not consume adequate power, the drive compensates accordingly. This is a particular advantage when water circulation stops, the pump runs dry or when pipes leak.

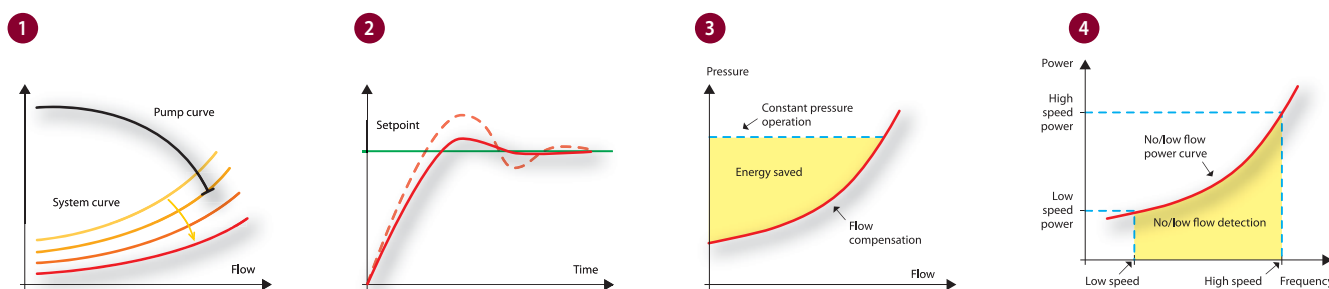

# Optimize system performance with EC+

Danfoss EC+ concept gives manufacturers of ventilation units the freedom to select their preferred motor from any supplier and control it with a VLT®

## Optimize PM motor performance

Danfoss has refined its VVC+ algorithm and optimised it for permanent magnet motors. This improvement makes it possible for owners to benefit from the high motor efficiency of EC technology. After entering the relevant motor data, the drive automatically optimizes the performance of the application.

## Free choice of technology

VLT® drives are equally efficient at controlling PM and asynchronous motors.

By providing vendors with the freedom to select the optimum combination of drive and motor, it is possible to offer the best possible system efficiency. This is a clear advantage compared to integrated systems, where it often is not possible to optimize the individual components.

## Easy maintenance

Component replacement as a result of wear and tear is not always possible without installing a complete new, integrated system. The EC+ concept answers this challenge by making service and maintenance easier, as only the affected component needs to be repaired/replaced in the event of malfunction.

Downtime is therefore reduced, and so are maintenance costs. These savings are the result of the fact that the EC+ concept is based on standardized components. All units can be shipped at short notice and installed with little effort.



EC motor with electronics being build into the fan impeller impacts the airflow through the impeller.

### EC motor + integrated electronics + fan

$\eta_{\text{Drive}} = 89\% \mid \eta_{\text{Fan}} = 66\% \mid \eta_{\text{System}} = 59\%$

Values related to ILK report

## Highest efficiency with EC+

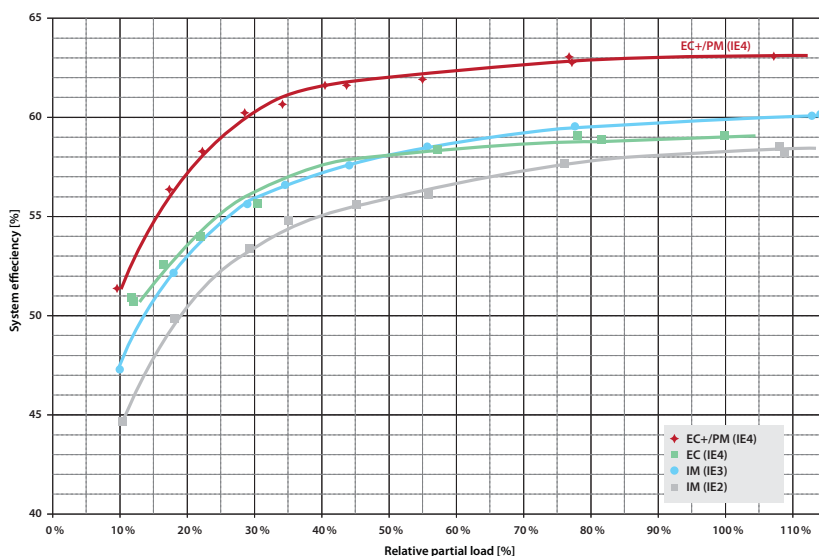

Tests at the Institute of Air Handling and Refrigeration (ILK) in Dresden have shown that the EC+ concept lowers the losses in ventilator systems by up to 10%, compared to conventional EC technology. This is the result of 3-5% higher system efficiency, depending on the nominal power size and the partial load.

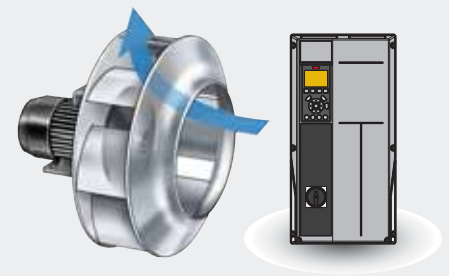

Plugfan with optimal and efficient airflow through the fan impeller. In combination with VSD and high efficient foot mounted permanent magnet motor.

### PM/EC motor + VSD + direct drive fan

$\eta_{\text{Drive}} = 89\% \mid \eta_{\text{Fan}} = 71\% \mid \eta_{\text{System}} = 63\%$

Values related to ILK report

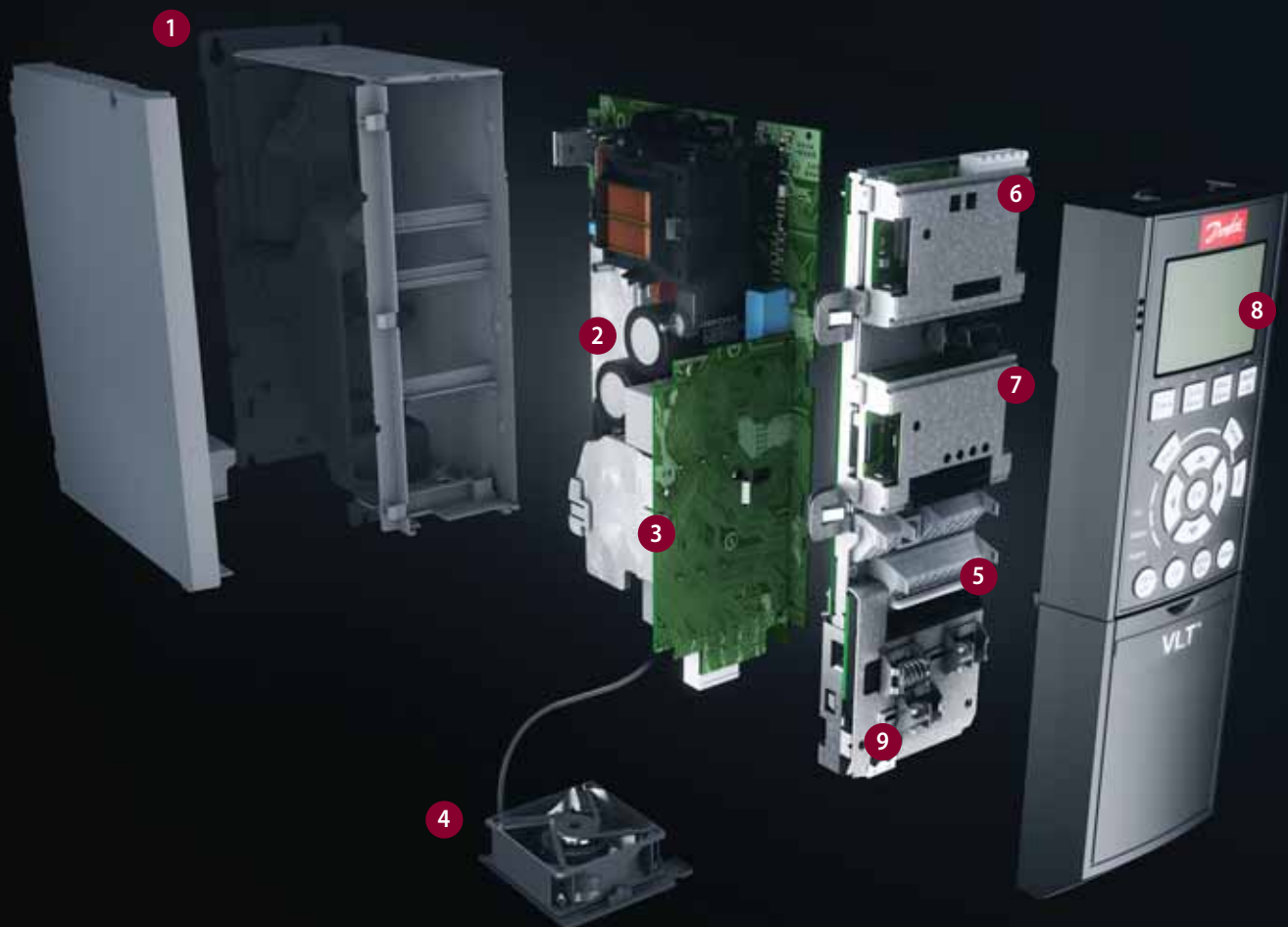

# Modular simplicity

Delivered fully assembled and tested to meet your specific requirements

## 1. Enclosure

The drive meets requirements for enclosure class IP20/Chassis. IP21/Type 1, IP55/Type 12, IP54/Type 12 or IP66/Type 4X.

## 2. EMC and Network effects

All versions of VLT® HVAC Drive comply as standard with EMC limits B, A1 or A2 according to the EN 55011 norm. The standard integrated DC coils ensure low harmonic load on the network according to EN 61000-3-12 and increase the lifetime of the DC link capacitors.

## 3. Protective coating

The electronic components are, as standard, coated as per IEC 60721-3-3, class 3C2. For harsh and aggressive environments, coating as per IEC 60721-3-3, class 3C3 is available.

## 4. Removable fan

Like most of the elements, the fan can be quickly removed and remounted for easy cleaning.

## 5. Control terminals

Double-stack, spring-loaded cage clamps enhance reliability and facilitate easy commissioning and service.

## 6. Fieldbus option

See complete list of available fieldbus options on page 34.

## 7. I/O extensions

A host of I/O options are available either factory mounted or as retrofit.

## 8. Display option

Danfoss VLT Drives' removable Local Control Panel is available with a variety of language packs: East European, West European, Asian and North American.

English and German are available in all drives.

Alternatively the drive can be commissioned via the built-in USB/RS485 connection or a fieldbus from with VLT® Motion Control Tool MCT 10 setup software.



### 9. 24 V external power supply

The external 24 V supply keeps the VLT® HVAC Drive logic “alive” when the AC mains is removed.

### 10. Mains disconnect

This switch interrupts the mains supply and has a free useable auxiliary contact.

### Safety

The VLT® HVAC Drive can optionally be delivered with the Safe Torque Off (Safe Stop) functionality suitable for category 3, performance level d according to EN 13849-1 and SIL 2 according to IEC 62061/IEC 61508. This feature prevents the drive from starting unintended.

### Built-in Smart Logic Controller

The Smart Logic Controller is a clever way to add customer-specific functionality to the drive and increase the opportunities for the drive, motor and application working together.

The controller monitors a specified event. When an event occurs, the controller performs a pre-defined action and then starts monitoring for the next pre-defined event. 20 steps of events and resulting actions are available before returning to the first set.

Logic functions can be selected; most of them run independently of the sequence control. This enables drives to monitor variables or signal defined events in an easy and flexible way independently of the motor control.



# The big picture

## An investment that pays

Increase application performance and streamline processes with energy efficient, adaptive motor control. Combine reliable, high performing solutions from a single supplier to reduce the lifetime costs of your applications.

### Minimize energy costs

As energy becomes increasingly expensive, variable speed control of electrical motors has proven to be one of the most effective cost-reducing measures available.

For example, by reducing the average speed of the motor from 100% to 80% in for example pumps or fans, 50% energy is saved. Reducing the average speed by 50% increases the savings to 80%.

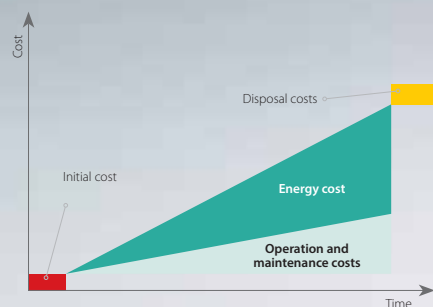

### Reduce total cost of ownership

Seen over its lifetime, the initial cost of a drive only amounts to 10% of the total cost of ownership; the remaining 90% cover energy consumption, service and maintenance.

During setup Automatic Motor Adaptation (AMA) and later during operation Automatic Energy Optimization (AEO) ensure that the drive is perfectly adapted to the attached motor and changing loads.

Once in operation VLT® drives serve reliably for their entire lifetime. Only requiring minimal maintenance, the VLT® HVAC Drives provide a fast return on investment and ultimately a competitive cost of ownership.

**Automatic Energy Optimization ensures that the motor voltage adapts automatically to changing loads. This provides an efficiency boost of up to 5-15%, reducing the cost of ownership substantially.**

**On the following pages we help you select the optimal VLT® for applications from 1.1 and 400 kW. For larger drives, please consult the selection guide for Danfoss VLT® High Power Drives.**



# Specifications

## Basic unit without extensions

Main supply (L1, L2, L3)	
Supply voltage	200 – 240 V ±10%
Supply voltage	380 – 480 V ±10%
Supply voltage	525 – 600 V ±10%
Supply voltage	525 – 690 V ±10%
Supply frequency	50/60 Hz
Displacement power factor (cos φ)	> 0.98 near unity
Switching on input supply L1, L2, L3	1–2 times/min.
Harmonic disturbance	Meets EN 61000-3-12

Output data (U, V, W)	
Output voltage	0 – 100% of supply voltage
Output frequency	0–590 Hz
Switching on output	Unlimited
Ramp times	1 – 3600 sec.

Digital inputs	
Programmable digital inputs	6*
Changeable to digital output	2 (terminal 27, 29)
Logic	PNP or NPN
Voltage level	0 – 24 V DC
Maximum voltage on input	28 V DC
Input resistance, Ri	Approx. 4 kΩ
Scan interval	5 ms

\* 2 can be used as digital outputs

Analog inputs	
Analogue inputs	2
Modes	Voltage or current
Voltage level	0 to +10 V (scaleable)
Current level	0/4 to 20 mA (scaleable)
Accuracy of analog inputs	Max. error: 0.5% of full scale

Pulse inputs	
Programmable pulse inputs	2*
Voltage level	0 – 24 V DC (PNP positive logic)
Pulse input accuracy (0.1 – 1 kHz)	Max. error: 0.1% of full scale

\* Utilize some of the digital inputs

Digital outputs	
Programmable digital/pulse outputs	2
Voltage level at digital/frequency output	0 – 24 V DC
Max. output current (sink or source)	40 mA
Maximum output frequency at frequency output	0 to 32 kHz
Accuracy on frequency output	Max. error: 0.1% of full scale

Analogue output	
Programmable analogue outputs	1
Current range at analogue output	0/4 – 20 mA
Max. load to common at analogue output (clamp 39)	500 Ω
Accuracy on analogue output	Max. error: 1% of full scale

Control card	
USB interface	1.1 (Full Speed)
USB plug	Type "B"
RS485 interface	Up to 115 kBaud
Max. load (10 V)	15 mA
Max. load (24 V)	200 mA

Relay output	
Programmable relay outputs	2
Max. terminal load (AC) on 1-3 (break), 1-2 (make), 4-6 (break) power card	240 V AC, 2 A
Max. terminal load (AC) on 4-5 (make) power card	400 V AC, 2 A
Min. terminal load on 1-3 (break), 1-2 (make), 4-6 (break), 4-5 (make) power card	24 V DC 10 mA, 24 V AC 20 mA

Surroundings/external	
Enclosure	IP: 00/20/21/54/55/66 UL Type: Chassis/1/12/4x Outdoor
Vibration test	1.0 g (D enclosures: 0.7 g)
Max. relative humidity	5% – 95% (IEC 721-3-3; Class 3K3 (non-condensing) during operation)
Ambient temperature	Max. 50° C w/o derating
Galvanic isolation of all	I/O supplies according to PELV
Aggressive environment	Designed for coated/standard 3C3/3C2 (IEC 60721-3-3)

Fieldbus communication	
Standard built-in:	Optional:
FC Protocol	VLT® PROFIBUS DP V1 MCA 101
N2 Metasys	VLT® DeviceNet MCA 104
FLN Apogee	VLT® LonWorks MCA 108
Modbus RTU	VLT® BACnet MCA 109
BACnet (embedded)	VLT® PROFINET MCA 120
	VLT® EtherNet/IP MCA 121
	VLT® Modbus TCP MCA 122

Protection mode for longest possible up-time	
– Electronic thermal motor protection against overload	
– Temperature monitoring of the heatsink ensures that the frequency converter trips if the temperature reaches 95° C ± 5° C	
– The frequency converter is protected against short-circuits on motor terminals U, V, W	
– The frequency converter is protected against earth faults on motor terminals U, V, W	
– Protection against mains phase loss	





# Connection examples

The numbers represent the terminals on the drive

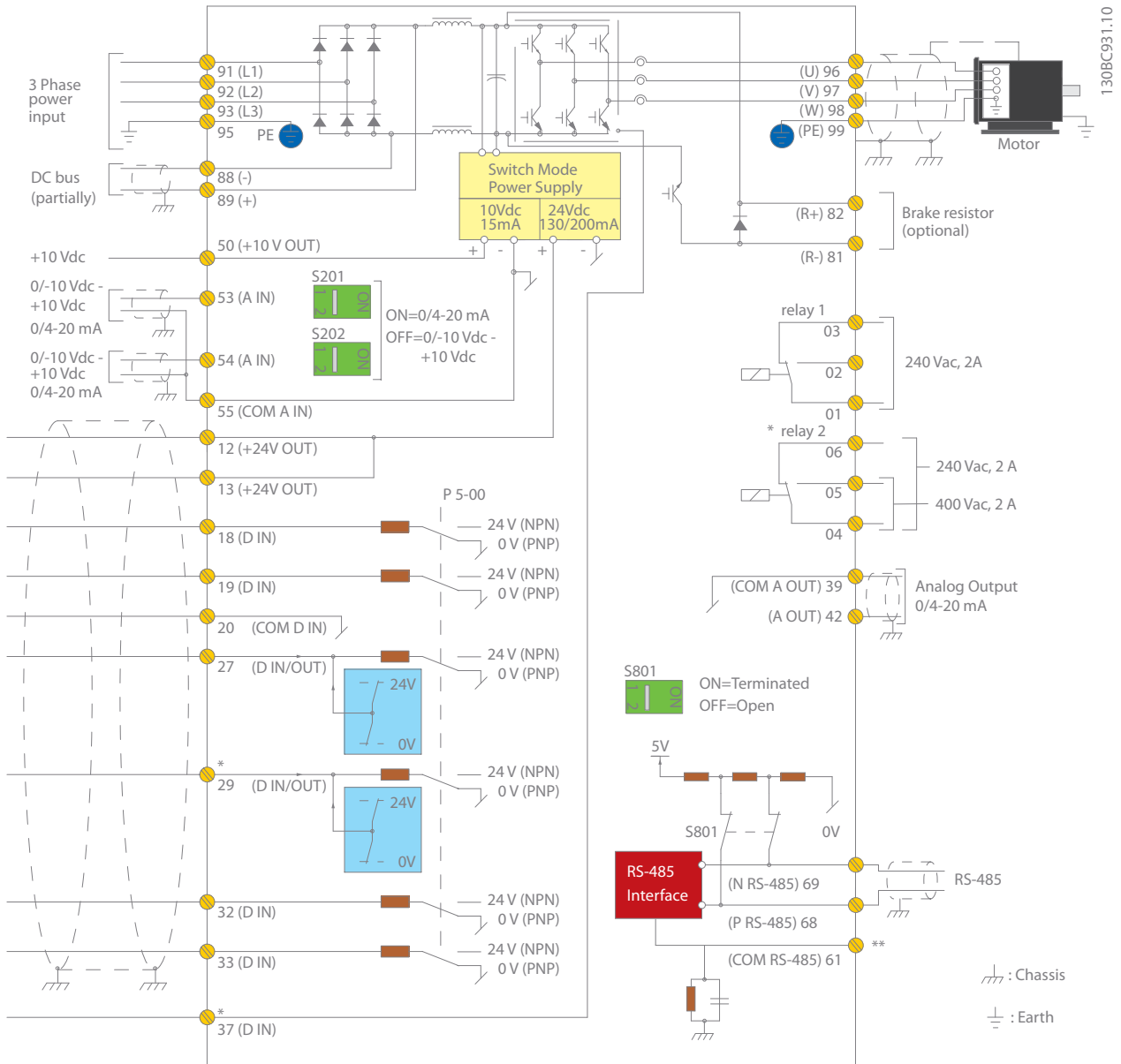

This diagram shows a typical installation of the VLT® HVAC Drive. Power is connected to the terminals 91 (L1), 92 (L2) and 93 (L3) and the motor is connected to 96 (U), 97 (V) and 98 (W).

Terminals 88 and 89 are used for load sharing between drives.

Analogue inputs can be connected to the 53 (V or mA), and for 54 (V or mA) terminals.

These inputs can be set up as either reference, feedback or thermistor inputs.

There are 6 digital inputs to be connected to terminals 18, 19, 27, 29, 32, and 33. Two digital input/output terminals (27 and 29) can be set up as digital outputs to show an actual status or warning. The terminal 42 analogue output can show process values such as  $0 - I_{max}$ .

On the 68 (P+) and 69 (N-) terminals' RS 485 interface, the drive can be controlled and monitored via serial communication.

*Diagram showing all electrical terminals without options.*  
 A = analog, D = digital  
 Terminal 37 is used for Safe Stop. For instructions on Safe Stop installation please refer to the section Safe Stop Installation of the Design Guide.  
 \*Terminal 37 is optional.  
 \*\* Do not connect cable screen

## VLT® HVAC Drive 200-240 V AC

Enclosure	IP 20 (IP 21*)/Chassis (Type 1)	A2			A3	
		IP 55 + IP 66/ Type 4X	A4 + A5		A5	
			P1K1	P1K5	P2K2	P3K0
Typical shaft output	[kW]	1.1	1.5	2.2	3	3.7
Typical shaft output at 208 V	[HP]	1.5	2.0	2.9	4.0	4.9
<b>Output current</b>						
Continuous (3 x 200 – 240 V)	[A]	6.6	7.5	10.6	12.5	16.7
Intermittent (3 x 200 – 240 V)	[A]	7.3	8.3	11.7	13.8	18.4
<b>Output power</b>						
Continuous (208 V AC)	[kVA]	2.38	2.70	3.82	4.50	6.00
<b>Rated input current</b>						
Continuous (3 x 200 – 240 V)	[A]	5.9	6.8	9.5	11.3	15.0
Intermittent (3 x 200 – 240 V)	[A]	6.5	7.5	10.5	12.4	16.5
Estimated power loss at rated max. load	[W]	63	82	116	155	185
Efficiency		0.96				
Max. cable size Mains, motor, brake	[mm <sup>2</sup> ] ([AWG])	4 (12)				
Max. pre-fuses	[A]	20			32	
<b>Weight</b>						
IP 20	[kg]	4.9			6.6	
IP 21	[kg]	5.5			7.5	
IP 55, IP 66	[kg]	9.7 (A4)/13.5 (A2 + A5)				13.5

Enclosure	IP 20 (IP 21*)/Chassis (Type 1)	B3			B4		C3		C4		
		IP 21/Type 1, IP 55 + IP 66//Type 4X	B1		B2	C1		C2			
			P5K5	P7K5	P11K	P15K	P18K	P22K	P30K	P37K	P45K
Typical shaft output	[kW]	5.5	7.5	11	15	18.5	22	30	37	45	
Typical shaft output at 208 V	[HP]	7.5	10	15	20	25	30	40	50	60	
<b>Output current</b>											
Continuous (3 x 200 – 240 V)	[A]	24.2	30.8	46.2	59.4	74.8	88	115	143	170	
Intermittent (3 x 200 – 240 V)	[A]	26.6	33.9	50.8	65.3	82.3	96.8	127	157	187	
<b>Output power</b>											
Continuous (208 V AC)	[kVA]	8.7	11.1	16.6	21.4	26.9	31.7	41.4	51.5	61.2	
<b>Rated input current</b>											
Continuous (3 x 200 – 240 V)	[A]	22	28	42	54	68	80	104	130	154	
Intermittent (3 x 200 – 240 V)	[A]	24.2	30.8	46.2	59.4	74.8	88	114	143	169	
Estimated power loss at rated max. load	[W]	269	310	447	602	737	845	1140	1353	1636	
Efficiency		0.96					0.97				
Max. cable size Mains, motor, brake	[mm <sup>2</sup> ] ([AWG])	10 (7)		35 (2)		50 (1) (B4 = 35 (2))		150 (300 MCM)		150 (300 MCM)	
Max. cable size mains With mains disconnect switch included	[mm <sup>2</sup> ] ([AWG])	16 (6)		35 (2)		50, 35, 35 (1, 2, 2)		95, 70, 70 (3/0, 2/0, 2/0)		185, 150, 120 (350 MCM, 300 MCM, 4/0)	
Max. pre-fuses	[A]	63		80		125		160		200	
<b>Weight</b>											
IP 20	[kg]	12		23.5		35		50			
IP 21, IP 55, IP 66	[kg]	23		27		45		65			

\* (A2, A3, B3, B4, C3 and C4 may be converted to IP21/Type 1 using a conversion kit.  
(Please see also items mechanical mounting in Operating Instructions and IP 21/Type 1 enclosure kit in the Design Guide.)

# VLT® HVAC Drive 380 – 480 V AC

Enclosure	IP 20 (IP 21*)/Chassis (Type 1)		A2					A3	
	IP 55 + IP 66 /Type 4X		A4 + A5					A5	
			P1K1	P1K5	P2K2	P3K0	P4K0	P5K5	P7K5
Typical shaft output	[kW]		1.1	1.5	2.2	3	4	5.5	7.5
Typical shaft output at 460 V	[HP]		1.5	2.0	2.9	4.0	5.0	7.5	10
<b>Output current</b>									
Continuous (3 x 380 – 440 V)	[A]		3	4.1	5.6	7.2	10	13	16
Intermittent (3 x 380 – 440 V)	[A]		3.3	4.5	6.2	7.9	11	14.3	17.6
Continuous (3 x 441 – 480 V)	[A]		2.7	3.4	4.8	6.3	8.2	11	14.5
Intermittent (3 x 441 – 480 V)	[A]		3.0	3.7	5.3	6.9	9.0	12.1	15.4
<b>Output power</b>									
Continuous (400 V AC)	[kVA]		2.1	2.8	3.9	5.0	6.9	9.0	11.0
Continuous (460 V AC)	[kVA]		2.4	2.7	3.8	5.0	6.5	8.8	11.6
<b>Rated input current</b>									
Continuous (3 x 380 – 440 V)	[A]		2.7	3.7	5.0	6.5	9.0	11.7	14.4
Intermittent (3 x 380 – 440 V)	[A]		3.0	4.1	5.5	7.2	9.9	12.9	15.8
Continuous (3 x 441 – 480 V)	[A]		2.7	3.1	4.3	5.7	7.4	9.9	13.0
Intermittent (3 x 441 – 480 V)	[A]		3.0	3.4	4.7	6.3	8.1	10.9	14.3
Estimated power loss at rated max. load	[W]		58	62	88	116	124	187	255
Efficiency			0.96				0.97		
Max. cable size (Mains, motor, brake)	[mm <sup>2</sup> ] ([AWG])						4 (12)		
Max. pre-fuses	[A]		10			20		32	
<b>Weight</b>									
IP 20	[kg]		4.8			4.9		6.6	
IP 55, IP 66	[kg]					9.7 (A4)/13.5 (A2 + A5)		14.2	

Enclosure	IP 20 (IP 21*)/Chassis (Type 1)		B3			B4			C3		C4	
	IP 21/Type 1, IP 55 + IP 66/Type 4X		B1			B2			C1		C2	
			P11K	P15K	P18K	P22K	P30K	P37K	P45K	P55K	P75K	P90K
Typical shaft output	[kW]		11	15	18.5	22	30	37	45	55	75	90
Typical shaft output at 460 V	[HP]		15	20	25	30	40	50	60	75	100	125
<b>Output current</b>												
Continuous (3 x 380 – 439 V)	[A]		24	32	37.5	44	61	73	90	106	147	177
Intermittent (3 x 380 – 439 V)	[A]		26.4	35.2	41.3	48.4	67.1	80.3	99	117	162	195
Continuous (3 x 440 – 480 V)	[A]		21	27	34	40	52	65	80	105	130	160
Intermittent (3 x 440 – 480 V)	[A]		23.1	29.7	37.4	44	61.6	71.5	88	116	143	176
<b>Output power</b>												
Continuous (400 V AC)	[kVA]		16.6	22.2	26	30.5	42.3	50.6	62.4	73.4	102	123
Continuous (460 V AC)	[kVA]		16.7	21.5	27.1	31.9	41.4	51.8	63.7	83.7	104	128
<b>Rated input current</b>												
Continuous (3 x 380 – 439 V)	[A]		22	29	34	40	55	66	82	96	133	161
Intermittent (3 x 380 – 439 V)	[A]		24.2	31.9	37.4	44	60.5	72.6	90.2	106	146	177
Continuous (3 x 440 – 480 V)	[A]		19	25	31	36	47	59	73	95	118	145
Intermittent (3 x 440 – 480 V)	[A]		20.9	27.5	34.1	39.6	51.7	64.9	80.3	105	130	160
Estimated power loss at rated max. load	[W]		278	392	465	525	698	739	843	1083	1384	1474
Efficiency							0.98					0.99
Max. cable size Mains, motor, brake	[mm <sup>2</sup> ] ([AWG])		10 (8)			35 (2)		50 (1) (B4 = 35 (2))		95 (4/0)	95 (4/0)	
Max. cable size mains With mains disconnect switch included	[mm <sup>2</sup> ] ([AWG])		16, 10, 10 (6, 8, 8)					50, 35, 35 (1, 2, 2)		95, 70, 70 (3/0, 2/0, 2/0)	185, 150, 120 (350 MCM, 300 MCM, 4/0)	
Max. pre-fuses	[A]		63	63	63	63	80	100	125	160	250	250
<b>Weight</b>												
IP 20	[kg]		12	12	12	23.5	23.5	23.5	35	35	50	50
IP 21, IP 55, IP 66	[kg]		23	23	23	27	27	45	45	45	65	65

\* (A2, A3, B3, B4, C3 and C4 may be converted to IP21 using a conversion kit. Please contact Danfoss.  
(Please see also items Mechanical mounting in Operating Instructions and IP 21/Type 1 Enclosure kit in the Design Guide.))  
1) With brake and load sharing 95 (4/0)

## VLT® HVAC Drive 3 x 380 – 480 V AC

Enclosure	IP 20		D3h			D4h		
	IP 21, IP 55		D1h + D5h + D6h			D2h + D7h + D8h		
			N110	N132	N160	N200	N250	N315
Typical shaft output (400 V)	[kW]		110	132	160	200	250	315
Typical shaft output (460 V)	[HP]		150	200	250	300	350	450
Typical shaft output (480 V)	[kW]		132	160	200	250	315	355
<b>Output current</b>								
Continuous (400 V)	[A]		212	260	315	395	480	588
Intermittent (440 V)	[A]		233	286	347	435	528	647
Continuous (460/500 V)	[A]		190	240	302	361	443	535
Intermittent (460/500 V)	[kVA]		209	264	332	397	487	588
<b>Output power</b>								
Continuous (400 V)	[kVA]		147	180	218	274	333	407
Continuous (460 V)	[kVA]		151	191	241	288	353	426
<b>Rated input current</b>								
Continuous (400 V)	[A]		204	251	304	381	463	567
Intermittent (460/500 V)	[A]		183	231	291	348	427	516
Estimated power loss at rated maximum load at 460 V	[W]		2555	2949	3764	4109	5129	6663
Efficiency			0.98					
Max. cable size Mains, motor, brake and loadsharing	[mm <sup>2</sup> ] ([AWG])		2 x 95 (2 x 3/0)			2 x 185 (2 x 350 mcm)		
Max. external input (mains) fuses	[A]		315	350	400	550	630	800
<b>Weight</b>								
IP 20, IP 21, IP 54	[kg]		62			125		

## VLT® HVAC Drive 525 – 600 V AC

Enclosure		IP 20 Chassis																	
IP 21/Type 1 IP 55, IP 66/Type 4x	[kW]	A3				A3				B3			B4		C3		C4		
		A5								B1			B2		C1		C2		
		P1K1	P1K5	P2K2	P3K0	P4K0	P5K5	P7K5	P11K	P15K	P18K	P22K	P30K	P37K	P45K	P55K	P75K	P90K	
Typical shaft output	[kW]	1.1	1.5	2.2	3	4	5.5	7.5	11	15	18.5	22	30	37	45	55	75	90	
<b>Output current</b>																			
Continuous (3 x 525 – 550 V)	[A]	2.6	2.9	4.1	5.2	6.4	9.5	11.5	19	23	28	36	43	54	65	87	105	137	
Intermittent (3 x 525 – 550 V)	[A]	2.9	3.2	4.5	5.7	7.0	10.5	12.7	21	25	31	40	47	59	72	96	116	151	
Continuous (3 x 525 – 600 V)	[A]	2.4	2.7	3.9	4.9	6.1	9.0	11.0	18	22	27	34	41	52	62	83	100	131	
Intermittent (3 x 525 – 600 V)	[A]	2.6	3.0	4.3	5.4	6.7	9.9	12.1	20	24	30	37	45	57	68	91	110	144	
<b>Output power</b>																			
Continuous (525 V AC)	[kVA]	2.5	2.8	3.9	5.0	6.1	9.0	11.0	18.1	21.9	26.7	34.3	41	51.4	61.9	82.9	100	130.5	
Continuous (575 V AC)	[kVA]	2.4	2.7	3.9	4.9	6.1	9.0	11.0	17.9	21.9	26.9	33.9	40.8	51.8	61.7	82.7	99.6	130.5	
<b>Rated input current</b>																			
Continuous (3 x 525-600 V)	[A]	2.4	2.7	4.1	5.2	5.8	8.6	10.4	17.2	20.9	25.4	32.7	39	49	59	78.9	95.3	124.3	
Intermittent (3 x 525 – 600 V)	[A]	2.7	3.0	4.5	5.7	6.4	9.5	11.5	19	23	28	36	43	54	65	87	105	137	
Estimated power loss at rated max. load	[W]	50	65	92	122	145	195	261	300	400	475	525	700	750	850	1100	1400	1500	
Efficiency		0.97	0.97	0.97	0.97	0.97	0.97	0.97	0.98	0.98	0.98	0.98	0.98	0.98	0.98	0.98	0.98	0.98	
Max. cable size IP 20, mains, motor, brake	[mm <sup>2</sup> ] ([AWG])	4 (12)							10 (8)			35 (2)		50 (1/0)		95 (4/0)	120 (250 MCM)		
Max. cable size IP 21/55/66, mains, motor, brake	[mm <sup>2</sup> ] ([AWG])	4 (12)							10 (8)			35, 25, 25 (2, 4, 4)		50 (1)		150 (300 MCM)			
Max. cable size mains With mains disconnect switch included	[mm <sup>2</sup> ] ([AWG])	4 (12)							16, 10, 10 (8, 8, 8)			50, 35, 35 (1, 2, 2)		95, 70, 70 (3/0, 2/0, 2/0)		185, 150, 120 (350 MCM, 300 MCM, 4/0)			
Max. pre-fuses	[A]	10	10	20	20	20	32	32	63	63	63	63	80	100	125	160	250	250	
<b>Weight</b>																			
IP 20	[kg]	6.5	6.5	6.5	6.5	6.5	6.6	6.6	12	12	12	23.5	23.5	23.5	35	35	50	50	
IP 21, IP 55, IP 66	[kg]	13.5	13.5	13.5	13.5	13.5	14.2	14.2	23	23	23	27	27	27	45	45	65	65	

## VLT® HVAC Drive 3 x 525-690 V AC

Enclosure	IP 20		A3						B4					C3			D3h					
	IP 21/IP 55								B2					C2								
			P1K1	P1K5	P2K2	P3K0	P4K0	P5K5	P7K5	P11K	P15K	P18K5	P22K	P30K	P37K	P45K	P55K	P75K	P90K			
Typical shaft output (690 V)	[kW]		1.1	1.5	2.2	3	4	5.5	7.5	11	15	18.5	22	30	37	45	55	75	90			
Output current (High overload 110% for 1 min.)																						
Continuous (3 x 525-550 V)	[A]		2.1	2.7	3.9	4.9	6.1	9	11	14	19	23	28	36	43	54	65	87	105			
Intermittent (3 x 525-550 V)	[A]		3.4	4.3	6.2	7.8	9.8	14.4	17.6	22.4	20.9	25.3	30.8	39.6	47.3	59.4	71.5	95.7	115.5			
Continuous kVA (3 x 551-690 V)	[A]		1.6	2.2	3.2	4.5	5.5	7.5	10	13	18	22	27	34	41	52	62	83	100			
Intermittent kVA (3 x 551-690 V)	[A]		2.6	3.5	5.1	7.2	8.8	12	16	20.8	19.8	24.2	29.7	37.4	45.1	57.2	68.2	91.3	110			
Output power																						
Continuous (550 V) (A3 525 V)	[kVA]		1.9	2.5	3.5	4.5	5.5	8.2	10	13.3	18.1	21.9	26.7	34.3	41.0	51.4	61.9	82.9	100			
Continuous (690 V)	[kVA]		1.9	2.6	3.8	5.4	6.6	9	12	15.5	21.5	26.3	32.3	40.6	49.0	62.1	74.1	99.2	119.5			
Rated input current																						
Continuous (3 x 525-550 V)	[A]		1.9	2.4	3.5	4.4	5.5	8	10	15	19.5	24	29	36	49	59	71	87	99			
Intermittent (3 x 525-550 V)	[A]		3	3.9	5.6	7.1	8.8	13	16	23.2	21.5	26.4	31.9	39.6	53.9	64.9	78.1	95.7	108.9			
Continuous kVA (3 x 551-690 V)	[A]		1.4	2	2.9	4	4.9	6.7	9	14.5	19.5	24	29	36	48	58	70	86	94.3			
Intermittent kVA (3 x 551-690 V)	[A]		2.3	3.2	4.6	6.5	7.9	10.8	14.4	23.2	21.5	26.4	31.9	39.6	52.8	63.8	77	94.6	112.7			
Estimated power loss at rated maximum load	[W]		44	60	88	120	160	220	300	150	220	300	370	440	740	900	1100	1500	1800			
Efficiency			0.96						0.98													
Max. cable cross section Mains, motor, brake and load sharing	[mm <sup>2</sup> ] ([AWG])		4 (12)						35 (2)													
Max. external input (mains) fuses	[A]		-						63			80		100		125		160		-		
Weight																						
IP 20	[kg]		6.6						21.5 (B4)					35 (C3)			62 (D3h)					
IP 21, IP 55	[kg]		-						27 (B2)					65 (C2) – 62 (D3h)								

## VLT® HVAC Drive 3 x 525-690 V AC

Enclosure	IP 20		D3h					D4h							
	IP 21, IP 55		D1h + D5h + D6h					D2h + D7h + D8h							
			N75K	N90K	N110	N132	N160	N200	N250	N315	N400				
Typical shaft output (525 V)	[kW]		55	75	90	110	132	160	200	250	315				
Typical shaft output (575 V)	[HP]		75	100	125	150	200	250	300	350	400				
Typical shaft output (690 V)	[kW]		75	90	110	132	160	200	250	315	400				
Output current															
Continuous (550 V)	[A]		90	113	137	162	201	253	303	360	418				
Intermittent (550 V)	[A]		99	124	151	178	221	278	333	396	460				
Continuous (575/690 V)	[A]		86	108	131	155	192	242	290	344	400				
Intermittent (575/690 V)	[kVA]		95	119	144	171	211	266	319	378	440				
Output power															
Continuous (525 V)	[kVA]		86	108	131	154	191	241	289	343	398				
Continuous (575 V)	[kVA]		86	108	130	154	191	241	289	343	398				
Continuous (690 V)	[kVA]		103	129	157	185	229	289	347	411	478				
Rated input current															
Continuous (550 V)	[A]		89	110	130	158	198	245	299	355	408				
Continuous (575 V)	[A]		85	106	124	151	189	234	286	339	390				
Continuous (690 V)	[A]		87	109	128	155	197	240	296	352	400				
Estimated power loss at 525/575 V	[W]		1162	1428	1739	2099	2646	3071	3719	4460	5023				
Estimated power loss at 690 V	[W]		1204	1477	1796	2165	2738	3172	3848	4610	5150				
Efficiency			0.98												
Max. cable size Mains, motor, brake and loadsharing	[mm <sup>2</sup> ] ([AWG])					2 x 95 (2 x 3/0)			2 x 185 (2 x 350 mcm)						
Max. external input (mains) fuses	[A]		160		315			350		400		500		550	
Weight															
IP 20, IP 21, IP 54	[kg]		62					125							

# Dimensions and air flow

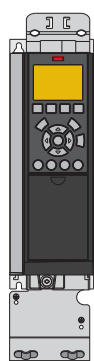

A2 IP 20

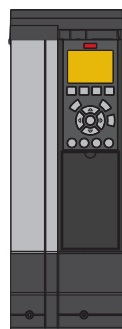
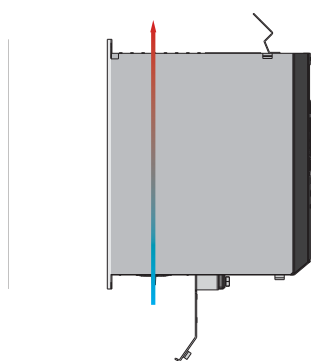

A3 with IP 21/Type 12 NEMA 1 Kit

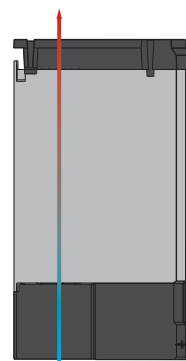

A4 IP 55 with mains disconnect

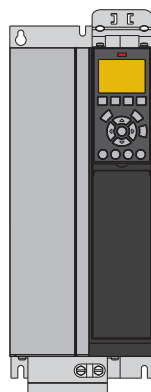
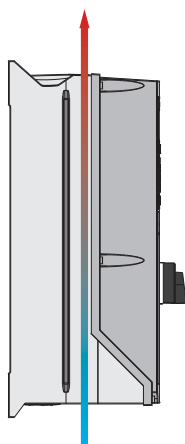

B3 IP 20

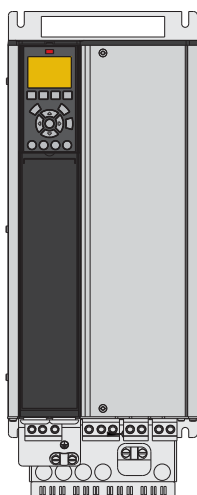
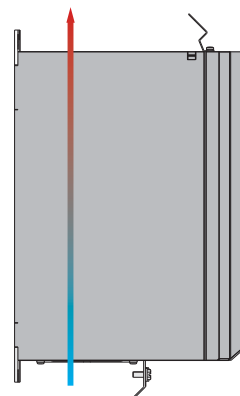

B4 IP 20

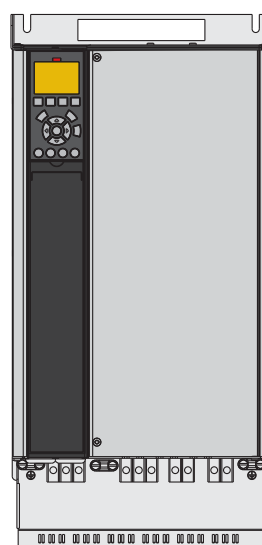
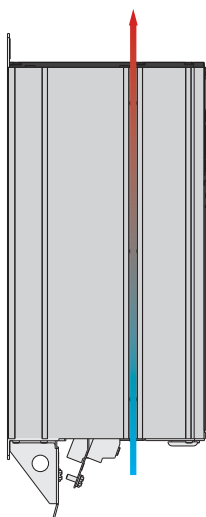

C3 IP 20

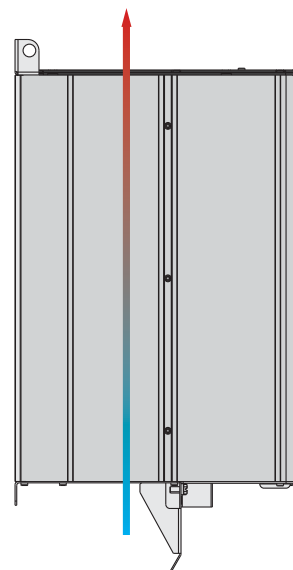

Please see the VLT® HVAC Drive FC 102 Design Guide for other frames, available at <http://www.danfoss.com/Products/Literature/VLT+Technical+Documentation.htm>

# A, B and C frames

Frame	VLT® HVAC Drive													
	A2		A3		A4	A5	B1	B2	B3	B4	C1	C2	C3	C4
Enclosure	IP 20	IP 21	IP 20	IP 21	IP 55/IP 66		IP 21/IP 55/ IP 66		IP 20		IP 21/IP 55/ IP 66		IP 20	
H mm Height of back plate	268	375	268	375	390	420	480	650	399	520	680	770	550	660
H1 mm With de-coupling plate for fieldbus cables	374	-	374	-	-	-	-	-	420	595	-	-	630	800
H2 mm Distance to mounting holes	254	350	257	350	401	402	454	624	380	495	648	739	521	631
W mm	90	90	130	130	200	242	242	242	165	230	308	370	308	370
W1 mm Distance between mounting holes	70	70	110	110	171	215	210	210	140	200	272	334	270	330
D mm Depth without option A/B	205	207	205	207	175	195	260	260	249	242	310	335	333	333
D1 mm With mains disconnect	-	-	-	-	206	224	289	290	-	-	344	378	-	-
D2 mm With option A/B	220	222	220	222	175	195	260	260	262	242	310	335	333	333
Air cooling	I (air space inlet) mm (inches)	100	100	100	100	100	200	200	200	200	200	225	200	225
	O (air space outlet) mm (inches)	100	100	100	100	100	200	200	200	200	200	225	200	225
Weight (kg)	4.9	5.3	6.6	7	9.7	13.5/ 14.2	23	27	12	23.5	45	65	35	50

A3 IP 20

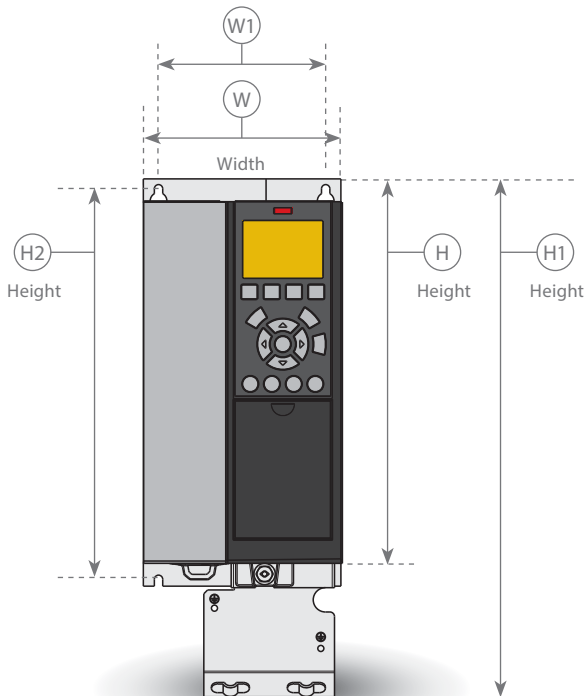

A4 IP 55 with mains disconnect

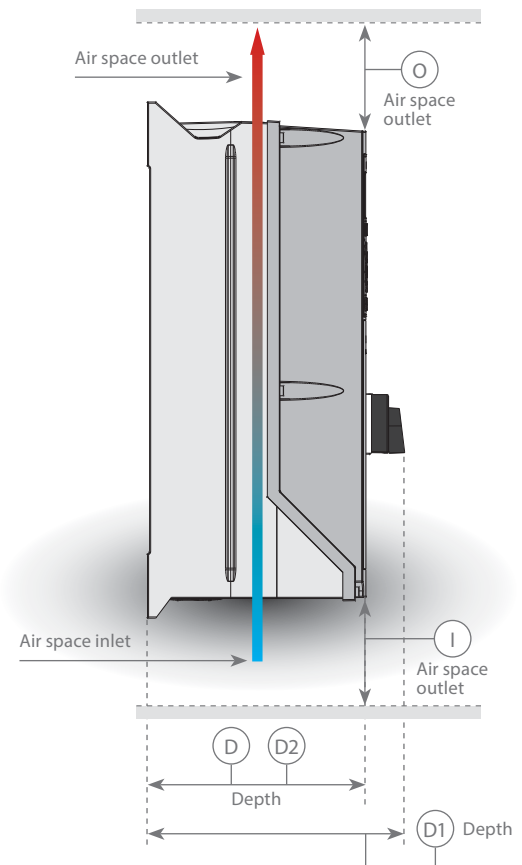

# Dimensions and air flow

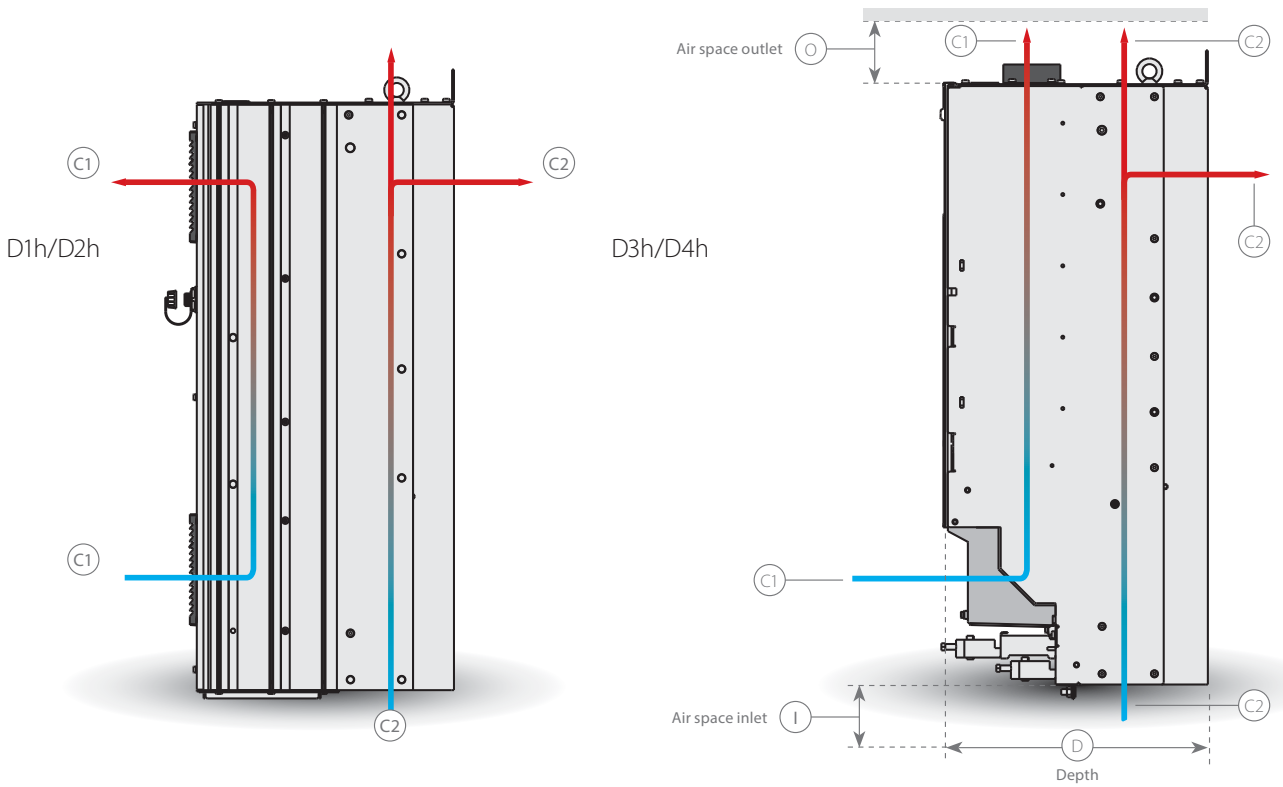
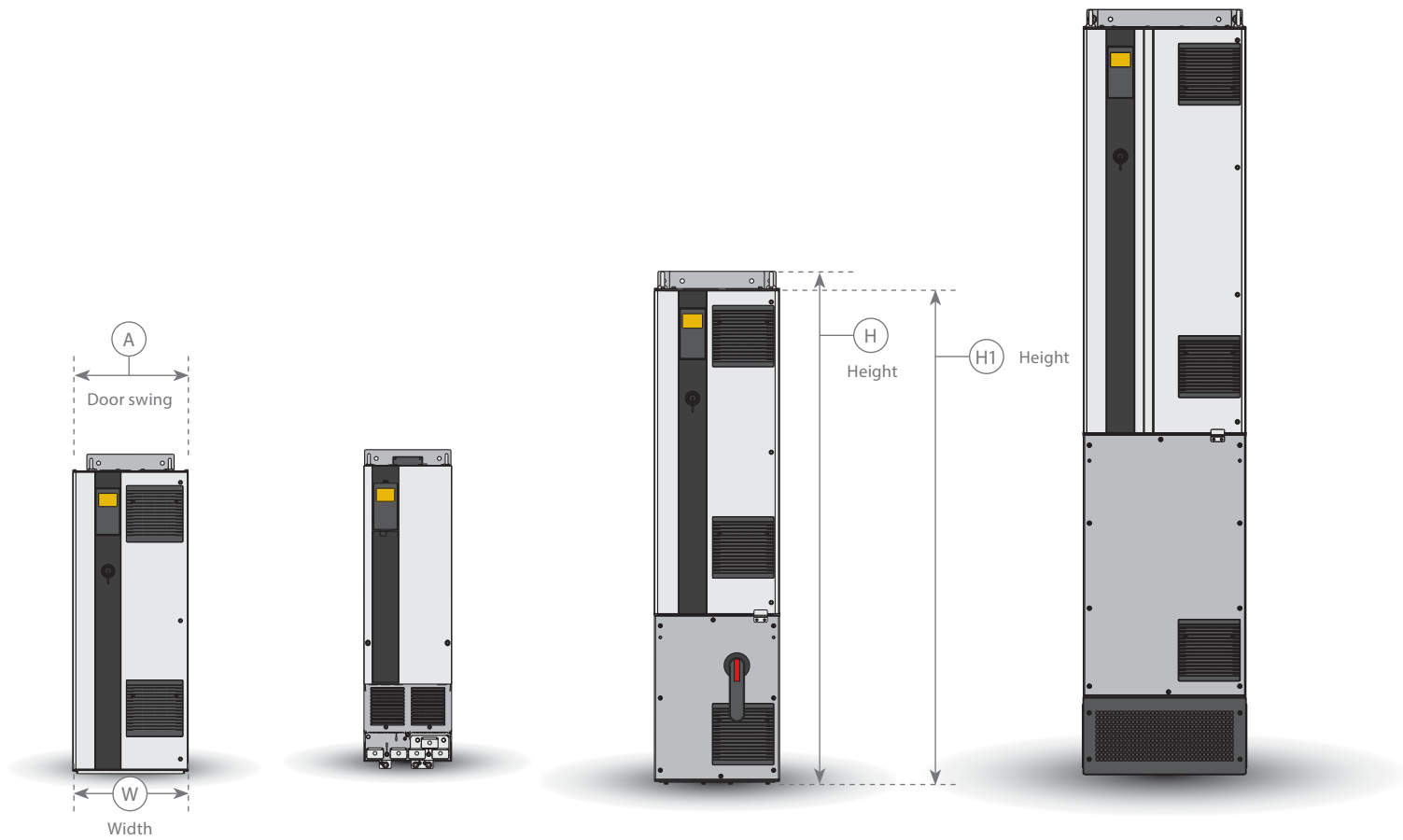

Please see the VLT® High Power Design Guide for other frames, available at <http://www.danfoss.com/Products/Literature/VLT+Technical+Documentation.htm>



# D frames

		VLT® HVAC Drive							
Frame		D1h	D2h	D3h	D4h	D5h	D6h	D7h	D8h
Enclosure		IP 21/IP 54		IP 20		IP 21/IP 54			
H mm Height of back plate		901	1107	909	1122	1324	1665	1978	2284
H1 mm Height of product		844	1050	844	1050	1277	1617	1931	2236
W mm		325	420	250	350	325	325	420	420
D mm		378	378	375	375	381	381	384	402
D1 mm With mains disconnect		-	-	-	-	426	426	429	447
Door swing A mm		298	395	n/a	n/a	298	298	395	395
Air cooling	I (air space inlet) mm	225	225	225	225	225	225	225	225
	O (air space outlet) mm	225	225	225	225	225	225	225	225
	C1	102 m³/h (60 cfm)	204 m³/h (120 cfm)	102 m³/h (60 cfm)	204 m³/h (120 cfm)	102 m³/h (60 cfm)		204 m³/h (120 cfm)	
	C2	420 m³/h (250 cfm)	840 m³/h (500 cfm)	420 m³/h (250 cfm)	840 m³/h (500 cfm)	420 m³/h (250 cfm)		840 m³/h (500 cfm)	

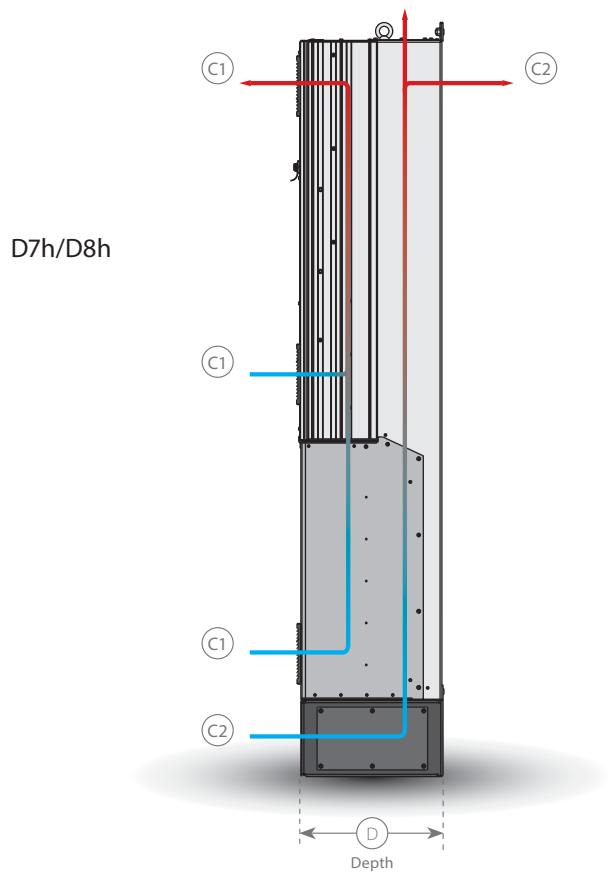
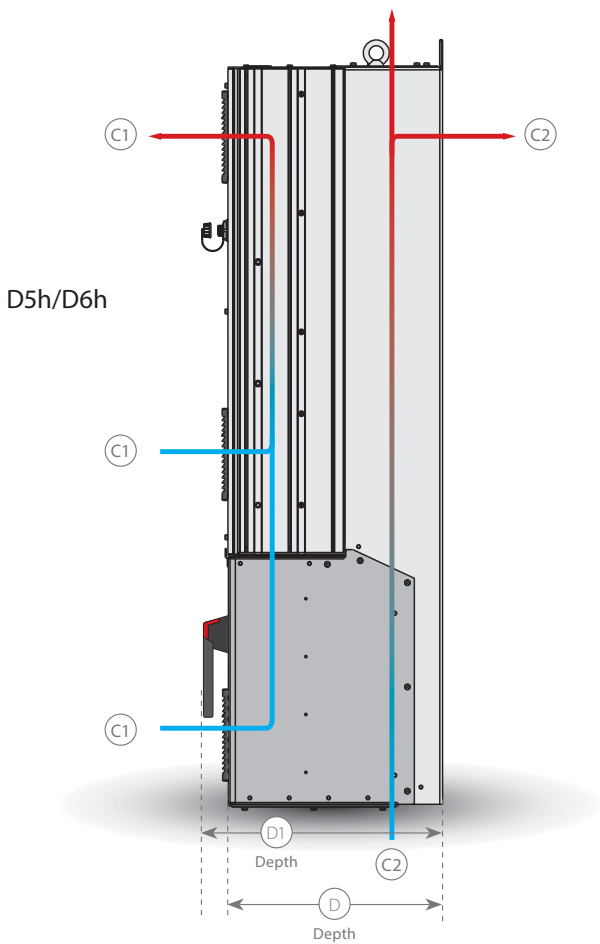



# A options: Fieldbuses

For A, B, C and D frames

## Fieldbus

### A

- VLT® PROFIBUS DP V1 MCA 101
- VLT® DeviceNet MCA 104
- VLT® LonWorks MCA 108
- VLT® BACnet MCA 109
- VLT® PROFINET MCA 120
- VLT® EtherNet/IP MCA 121
- VLT® Modbus TCP MCA 122

### VLT® PROFIBUS DP MCA 101

Operating the frequency converter via a fieldbus enables you to reduce the cost of your system, communicate faster and more efficiently, and benefit from an easier user interface.

- VLT® PROFIBUS DP MCA 101 provides wide compatibility, a high level of availability, support for all major PLC vendors, and compatibility with future versions
- Fast, efficient communication, transparent installation, advanced diagnosis and parameterisation and auto-configuration of process data via GSD-file
- A-cyclic parameterisation using PROFIBUS DP-V1, PROFIdrive or Danfoss FC profile state machines, PROFIBUS DP-V1, Master Class 1 and 2

#### Ordering number

130B1100 standard, 130B1200 coated

### VLT® DeviceNet MCA 104

VLT® DeviceNet MCA 104 offers robust, efficient data handling thanks to advanced Producer/Consumer technology.

- This modern communications model offers key capabilities that let you effectively determine what information is needed and when
- Benefit also from ODVA's strong conformance testing policies, which ensure that products are interoperable

#### Ordering number

130B1102 standard, 130B1202 coated

### VLT® LonWorks MCA 108

LonWorks is a fieldbus system developed for building automation. It enables communication between individual units in the same system (peer-to-peer) and thus supports decentralising of control.

- No need for big main station (master-follower)
- Units receive signals directly
- Supports Echelon free-topology interface (flexible cabling and installation)
- Supports embedded I/Os and I/O options (easy implementation of de-central I/Os)
- Sensor signals can quickly be moved to another controller via bus cables
- Certified as compliant with LonMark ver. 3.4 specifications

#### Ordering number

130B1106 standard, 130B1206 coated

## VLT® BACnet MCA 109

The open communications protocol for world-wide building automation. The BACnet protocol is an international protocol that efficiently integrates all parts of building automation equipment from the actuator level to the building management system.

Via the BACnet option it is possible to read all analogue and digital inputs and control all analogue and digital outputs of the VLT® HVAC Drive. All inputs and outputs can be operated independently of the drive's functions and thus work as remote I/Os:

- COV (Change of Value)
- Read/write Property Multiple
- Alarm/Warning handling

### Ordering number

130B1144 standard, 130B1244 coated

## VLT® PROFINET MCA 120

VLT® PROFINET MCA 120 uniquely combines the highest performance with the highest degree of openness. The MCA120 gives the user access to the power of Ethernet. The option is designed so that many of the features from the PROFIBUS MCA 101 can be reused, minimising user effort to migrate PROFINET, and securing the investment in PLC program.

### Other features:

- Built-in web server for remote diagnosis and reading out of basic drive parameters
- Support of DP-V1 Diagnostic allows easy, fast and standardized handling of warning and fault information into the PLC, improving bandwidth in the system

PROFINET encompasses a suite of messages and services for a variety of manufacturing automation applications, including control, configuration and information.

### Ordering number

130B1135 standard, 130B1235 coated

## VLT® EtherNet/IP MCA 121

Ethernet is the future standard for communication at the factory floor. The VLT® EtherNet/IP MCA 121 is based on the newest technology available for industrial use and handles even the most demanding requirements. EtherNet/IP extends commercial off-the-shelf Ethernet to the Common Industrial Protocol (CIP™) – the same upper-layer protocol and object model found in DeviceNet.

The VLT® MCA 121 offers advanced features as:

- Built-in high performance switch enabling line-topology, and eliminating the need for external switches
- Advanced switch and diagnoses functions
- Built-in web server
- E-mail client for service notification
- Unicast and Multicast communication

### Ordering number

130B1119 standard, 130B1219 coated

## VLT® Modbus TCP MCA 122

Modbus TCP is the first industrial Ethernet based protocol for automation. The VLT® Modbus TCP MCA 122 connects to Modbus TCP based networks. It is able to handle connection interval down to 5 ms in both directions, positioning it among the fastest performing

Modbus TCP devices in the market. For master redundancy it features hot swapping between two masters.

### Other features:

- Built-in web-server for remote diagnosis and reading out basic drive parameters
- An e-mail noticator can be configured for sending an e-mail message to one or several receivers, if certain warnings or alarms occurs, or has cleared again

### Ordering number

130B1196 standard, 130B1296 coated

## VLT® DeviceNet Converter MCA 194

The VLT® DeviceNet Converter MCA 194 emulates VLT® 5000 commands in the VLT® AutomationDrive. This means that a VLT® 5000 can be replaced by the VLT® AutomationDrive or an existing system can be expanded, without costly change of the PLC program.

For a later upgrade to a different fieldbus, the installed converter can easily be removed and replaced with a different option. This secures the investment without losing flexibility. The option emulates I/O instances & explicit messages of a VLT® 5000.

### Ordering number

NA standard, 130B5601 coated

# B options: Functional extensions

For A, B, C and D frames



## Funcional extensions

### B

VLT® General Purpose MCB 101

VLT® Relay Option MCB 105

VLT® Analog I/O Option MCB 109

VLT® PTC Thermistor Card MCB 112

VLT® Sensor Input Card MCB 114

VLT® Safe Option MCB 140 Series

## VLT® General Purpose I/O MCB 101

This I/O option offers an extended number of control inputs and outputs:

- 3 digital inputs 0-24 V:  
Logic '0' < 5 V; Logic '1' > 10V
- 2 analogue inputs 0-10 V:  
Resolution 10 bit plus sign
- 2 digital outputs NPN/PNP push pull
- 1 analogue output 0/4-20 mA
- Spring loaded connection

### Ordering number

130B1125 standard, 130B1212 coated

## VLT® Relay Option MCB 105

Makes it possible to extend relay functions with 3 additional relay outputs.

### Max. terminal load:

- AC-1 Resistive load ..... 240 V AC 2 A
- AC-15 Inductive  
load @cos fi 0.4 ..... 240 V AC 0.2 A
- DC-1 Resistive load ..... 24 V DC 1 A
- DC-13 Inductive  
load @cos fi 0.4 ..... 24 V DC 0.1 A

### Min. terminal load:

- DC 5 V ..... 10 mA
- Max switch rate at rated  
load/min. load ..... 6 min<sup>-1</sup>/20 sec<sup>-1</sup>
- Protects control cable connection
- Spring-loaded control wire connection

### Ordering number

130B1110 standard, 130B1210 coated

## VLT® Analog I/O Option MCB 109

This analogue input/output option is easily fitted in the frequency converter for upgrading to advanced performance and control using the additional in/outputs. This option also upgrades the frequency converter with a battery back-up supply for the frequency converter's built-in clock. This provides stable use of all frequency converter clock functions as timed actions etc.

- 3 analogue inputs, each configurable as both voltage and temperature input
- Connection of 0-10 V analogue signals as well as PT1000 and NI1000 temperature inputs
- 3 analogue outputs each configurable as 0-10 V outputs
- Incl. back-up supply for the standard clock function in the frequency converter

# B options: Functional extensions

For A, B, C and D frames



The back-up battery typically lasts for 10 years, depending on environment.

**Ordering number**  
130B1143 standard, 130B1243 coated

## VLT® PTC Thermistor Card MCB 112

ATEX-compliant module with thermal protection for single EEx d motors (Ziehl MS 220 DA).

- 1 PTB-certified thermistor input
- 1 switch-off signal for the integrated Safe Torque Off function (STO)
- 1 logic output for error identification

**Ordering number**  
NA standard, 130B1137 coated

*\* for use of this option STO-function is needed (optional terminal 37, see page 21 "Safety")*

## VLT® Sensor Input Card MCB 114

The option protects the motor from being overheated by monitoring the bearings and windings temperature in the motor. Both limits as well as action are adjustable, and the individual sensor temperature is visible as a read-out on the display or by fieldbus.

- Protects the motor from overheating
- Three self-detecting sensor inputs for 2 or 3 wire PT100/PT1000 sensors
- One additional analogue input 4-20 mA

**Ordering number**  
130B1172 standard, 130B1272 coated

## VLT® Safe Option MCB 140 Series

VLT® Safe Option MCB 140 Series are safety options providing Safe Stop 1 (SS1), Safely Limited Speed (SLS) and Safe Speed Monitor (SSM) functionality.

The options can be used up to PL e according to ISO 13849-1.

MCB 140 is a standard B-Option while MCB 141 offers the same functionality in an external 45 mm housing. MCB141 enables the user to use the MCB 140 functionality also if another B-Option is used.

Different operating modes can be easily configured by using the on board display and buttons. The options provide only a limited set of parameters for easy and fast parameterization.

- MCB 140 standard B-Option
- MCB 141 external Option
- Single channel or dual channel operation possible
- Proximity switch as speed feedback
- SS1, SLS and SMS functionality
- Easy and fast parameterization

**Ordering number**  
130B6443 MCB 140, 130B6447 MCB 141

# D option: External power supply

For A, B, C and D frames



## Option slot

D

VLT® 24 V DC Supply Option MCB 107

## VLT® 24 V DC Supply MCB 107

The option is used to connect an external DC supply to keep the control section and any installed option alive during power failure.

- Input voltage range...24 V DC +/- 15% (max. 37 V in 10 sec.)
- Max. input current .....2.2 A
- Max. cable length .....75 m
- Input capacitance load .....< 10 uF
- Power-up delay .....< 0.6 s

**Ordering number**  
130B1108 standard, 130B1208 coated

# Accessories

For A, B, C and D frames

## LCP

VLT® Control Panel LCP 101 (Numeric)  
Ordering number: 130B1124

VLT® Control Panel LCP 102 (Graphical)  
Ordering number: 130B1107

LCP Panel Mounting Kit  
Ordering number for IP20 enclosure  
130B1113: With fasteners, gasket, graphical LCP and 3 m cable  
130B1114: With fasteners, gasket, numerical LCP and 3 m cable  
130B1117: With fasteners, gasket and without LCP and with 3 m cable  
130B1170: With fasteners, gasket and without LCP

Ordering number for IP55 enclosure  
130B1129: With fasteners, gasket, blind cover and 8 m "free end" cable

## Power Options\*

VLT® Sine-Wave Filter MCC 101

VLT® dU/dt Filter MCC 102

VLT® Common Mode Filters MCC 105

VLT® Advanced Harmonic Filter AHF 005/010

VLT® Brake Resistors MCE 101

## Accessories

Profibus SUB-D9 Adapter  
IP 20, A2 and A3  
Ordering number: 130B1112

USB Extension  
Ordering number:  
130B1155: 350 mm cable  
130B1156: 650 mm cable

IP 21/Type 1 (NEMA 1) Kit  
Ordering number  
130B1122: For frame size A2  
130B1123: For frame size A3  
130B1187: For frame size B3  
130B1189: For frame size B4  
130B1191: For frame size C3  
130B1193: For frame size C4

Motor connector  
Ordering number:  
130B1065: frame A2 to A5 (10 pieces)

Mains connector  
Ordering number:  
130B1066: 10 pieces mains connectors IP 55  
130B1067: 10 pieces mains connectors IP20/21

Relays 1 terminal  
Ordering number: 130B1069 (10 pieces 3 pole connectors for relay 01)

Relays 2 terminal  
Ordering number: 130B1068 (10 pieces 3 pole connectors for relay 02)

Control card terminals  
Ordering number: 130B0295

\*Ordering number: See relevant Design Guide



# Power and enclosures

VLT® HVAC Drive		T2 200 – 240 V				T4/T5 380 – 480 V						T6 525 – 600 V				T7 525 – 690 V											
FC 102	kW	A	A				A						A				A										
			IP 20	IP 21	IP 55	IP 66	≤440 V	>440 V	IP 20	IP 21	IP 54	IP 55	IP 66	≤550 V	>550 V	IP 20	IP 21	IP 55	IP 66	550 V	690 V	IP 20	IP 21	IP 54	IP 55	IP 66	
P1K1	1.1	6.6					3	2.7						2.6	2.4					2.1	1.6						
P1K5	1.5	7.5	A2	A2	A4 A5	A4 A5	4.1	3.4	A2	A2		A4 A5	A4 A5	2.9	2.7	A3	A3	A5	A5	2.7	2.2	A3	A3		A5	A5	
P2K2	2.2	10.6					5.6	4.8						4.1	3.9					3.9	3.2						
P3K0	3.0	12.5	A3	A3	A5	A5	7.2	6.3						5.2	4.9					4.9	4.5						
P3K7	3.7	16.7																									
P4K0	4.0						10	8.2	A2	A2		A4/A5	A4/A5	6.4	6.1					6.1	5.5						
P5K5	5.5	24.2					13	11						9.5	9	A3	A3	A5	A5	9	7.5	A3	A3		A5	A5	
P7K5	7.5	30.8	B3	B1	B1	B1	16	14.5	A3	A3		A5	A5	11.5	11					11	10						
P11K	11	46.2					24	21						19	18					14	13						
P15K	15	59.4					32	27	B3	B1		B1	B1	23	22	B3	B1	B1	B1	19	18						
P18K	18.5	74.8	B4				37.5	34						28	27					23	22	B4	B2		B2		
P22K	22	88					44	40						36	34					28	27						
P30K	30	115	C3	C1	C1	C1	61	52	B4	B2		B2	B2	43	41	B4	B2	B2	B2	36	34						
P37K	37	143					73	65						54	52					43	41						
P45K	45	170	C4	C2	C2	C2	90	80						65	62	C3	C1	C1	C1	54	52						
P55K	55						106	105						87	83					65	62	C3	C2		C2		
P75K	75						147	130						105	100					87	83						
P90K	90						177	160	C4	C2		C2	C2	137	131	C4	C2	C2	C2	105	100						
N75K*	75																		90	86							
N90K*	90																		113	108							
N110	110						212	190											137	131			D3h	D1h D5h D6h	D1h D5h D6h		
N132	132						260	240	D3h	D5h D6h	D1h D5h D6h								162	155							
N160	160						315	302											201	192							
N200	200						395	361											253	242							
N250	250						480	443	D4h	D2h D7h D8h	D2h D7h D8h								303	290			D4h	D2h D7h D8h	D2h D7h D8h		
N315	315						588	535											360	344							
N400*	400																		418	400							

\*Only available in 690 V

- IP 20/Chassis ■
- IP 21/Type 1 ■
- IP 21 with upgrade kit – available in US only ■
- IP 54/Type 12 ■
- IP 55/Type 12 ■
- IP 66/NEMA 4X ■





# What VLT® is all about

Danfoss VLT Drives is the world leader among dedicated drives providers – and still gaining market share.

## Environmentally responsible

VLT® products are manufactured with respect for the safety and well-being of people and the environment.

All frequency converter factories are certified according to ISO 14001 and ISO 9001 standards.

All activities are planned and performed taking into account the individual employee, the work environment and the external environment. Production takes place with a minimum of noise, smoke or other pollution and environmentally safe disposal of the products is pre-prepared.

## UN Global Compact

Danfoss has signed the UN Global Compact on social and environmental responsibility and our companies act responsibly towards local societies.

## Impact on energy savings

One year's energy savings from our annual production of VLT® drives will save the energy equivalent to the energy production from a major power plant. Better process control at the same time improves product quality and reduces waste and wear on equipment.

## Dedicated to drives

Dedication has been a key word since 1968, when Danfoss introduced the world's first mass produced variable speed drive for AC motors – and named it VLT®.

Twenty five hundred employees develop, manufacture, sell and service drives and soft starters in more than one hundred countries, focused only on drives and soft starters.

## Intelligent and innovative

Developers at Danfoss VLT Drives have fully adopted modular principles in development as well as design, production and configuration.

Tomorrow's features are developed in parallel using dedicated technology platforms. This allows the development of all elements to take place in parallel, at the same time reducing time to market and ensuring that customers always enjoy the benefits of the latest features.

## Rely on the experts

We take responsibility for every element of our products. The fact that we develop and produce our own features, hardware, software, power modules, printed circuit boards, and accessories is your guarantee of reliable products.

## Local backup – globally

VLT® motor controllers are operating in applications all over the world and Danfoss VLT Drives' experts located in more than 100 countries are ready to support our customers with application advice and service wherever they may be.

Danfoss VLT Drives experts don't stop until the customer's drive challenges are solved.

