

HMI DOOR MOUNTING KIT- MOUNTING INSTRUCTIONS

1. INTRODUCTION

The kit is used for remote control drives. It is installed on the door of a cabinet. The kit maintains IP54/UL Type 12* integrity of the mounting location in the front side (back side is IP20). UL file number: E171278.

For the installation, you need the following parts (see picture below):

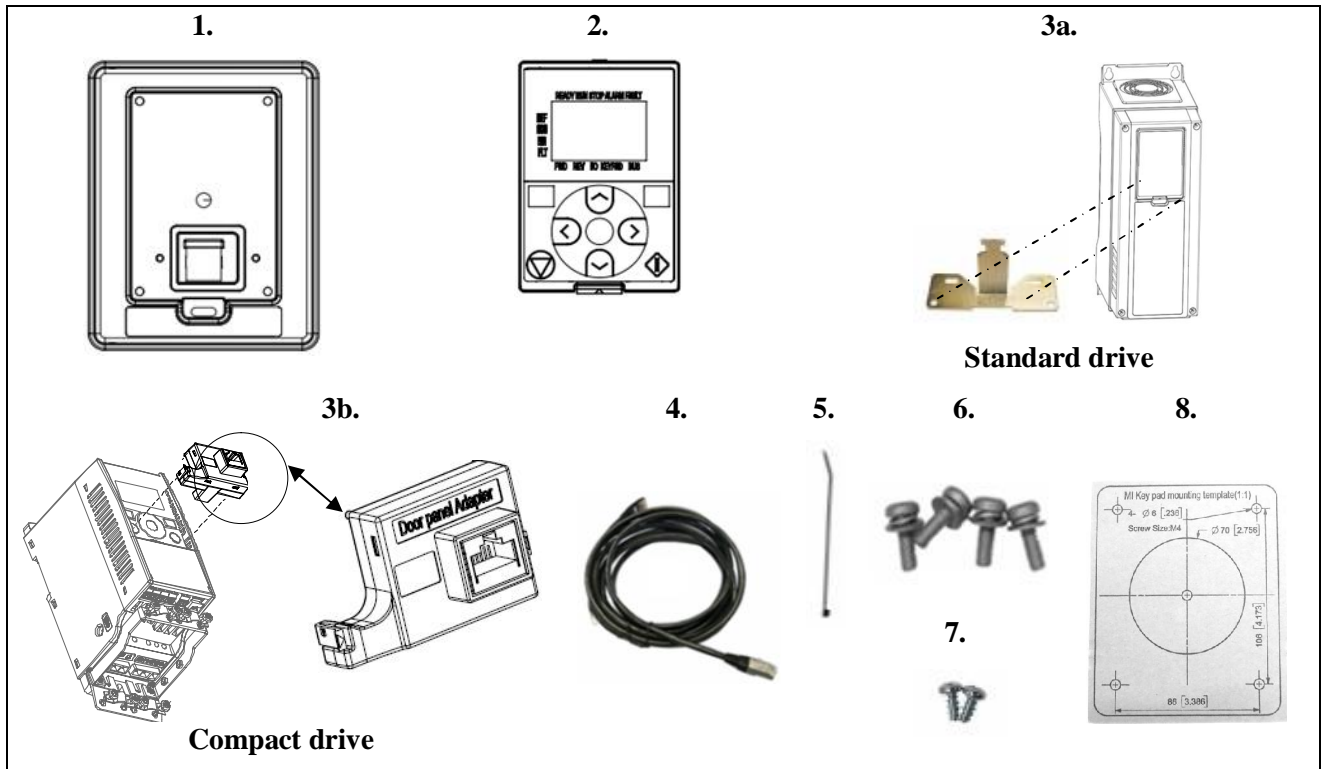

Figure 1. Door mounting kit parts

1. Control panel base
2. Control Panel (**standard drive** kit do not include any panel, user order control panel with graphical display or text display separately. **compact drive** Kit include control panel with text display)
- 3a. Cable support (**only available for standard drive**)
- 3b. Adapter (**only available for compact drive**)
4. Data cable with attached grounding cable
5. Cable tie (**Standard drive x2; Compact drive x 1**)
6. Screws (M4X16 4 pcs)
7. Screws (PT3.5X8 2 pcs, **only available for standard drive**)
8. Mounting template

NOTE:

- 1) Should use the Text panel (2.) built after **the B.ID 130420 (20th Apr 2013)**.
- 2) When used with Standard drive HVAC and Compact drive the LED in the door mounting kit is always **off** since Item 1 (door panel base) **B.ID 130905(5th Sep 2013)** serial number S00000252299.
- 3) When with Standard drive series others than HVAC, make sure use it after **B.ID 131120 (20th Nov 2013)**. If used with older boards the LED does not change according to the run, stop, alarm and fault states of the drive.
- 4) **MAKE SURE THAT YOU HAVE RECEIVED ALL NECESSARY PARTS!**

2. MOUNTING PROCEDURE

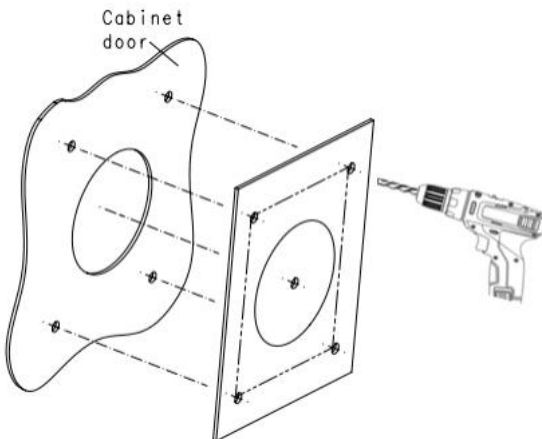
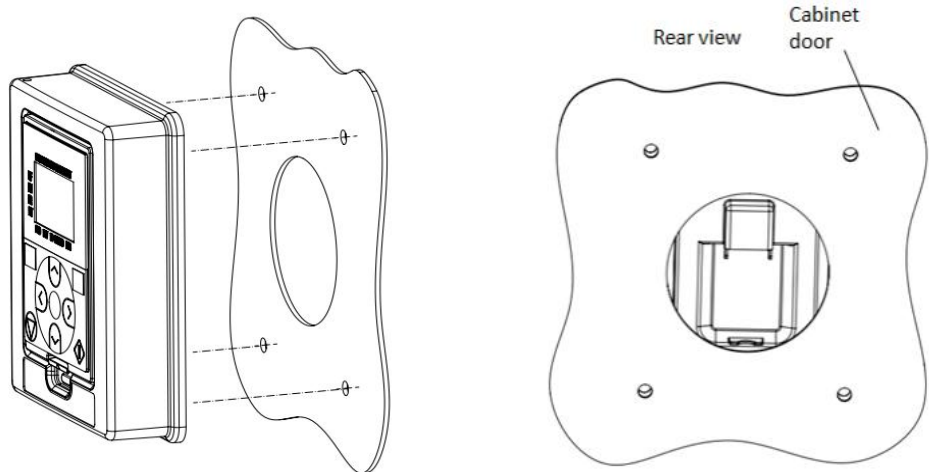
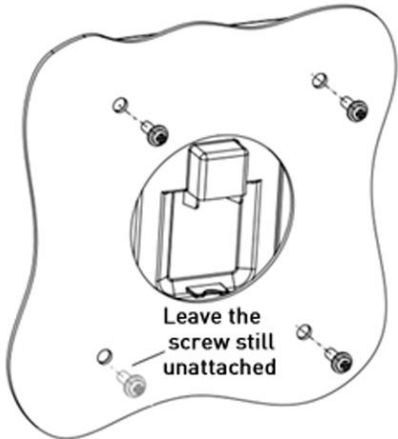
<p>1</p>	<p>Place the mounting template (7.) on the door or wall.</p> <p>Make a hole exactly the same size as the template for installation of the door panel base (1.).</p> <p>Remove the mounting template (7.) from the door or wall.</p> 
<p>2</p>	<p>Place the Door panel base (1.) toward the opening so that the screw holes you made in the cabinet door meet the bushings on the backside of the base. See figures below.</p> 
<p>3</p>	<p>Fix the base on the cabinet door by tightening the screws (5.).</p> 

<p>4</p>	<p>Fix the grounding cable (4.) against the backside of the cabinet door through one of the screw holes. Then use Cable tie (5) insert into the hole as dot line indicated at back of Door panel base (1) to tie cable.</p> <p>NOTE: Ensure that a proper contact with the cabinet door is achieved.</p> <p>Remove the paint from the metal surface if necessary.</p> <p>Don't forget to place the washers (attached to the screws) between the door and the screws. The tightening torque is 1.5 Nm.</p> <p>Connect the data cable (4.) to the terminal of the panel.</p> <p>Do not connect Inverter and Motor's PE wire together with Door panel's grounding cable.</p>
<p>5a</p>	<p>Attach the cable support in the control panel base of the AC drive using the screw(7.)</p> <p>(Only for standard drive)</p>

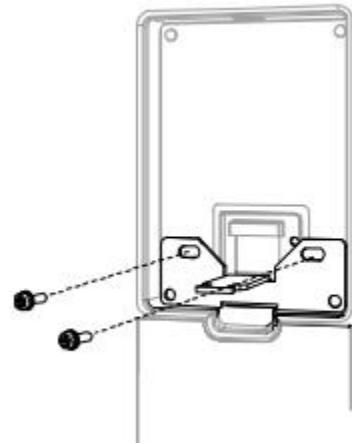
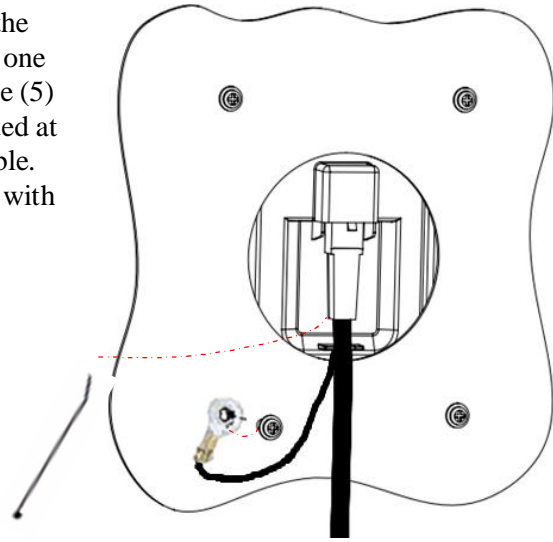

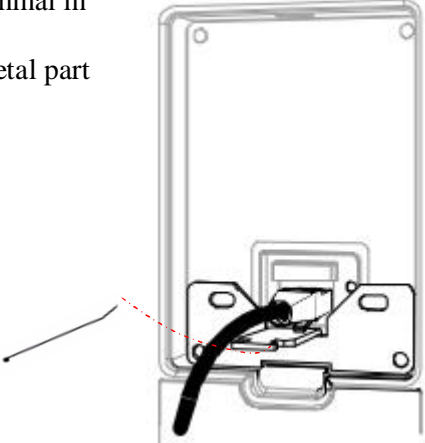
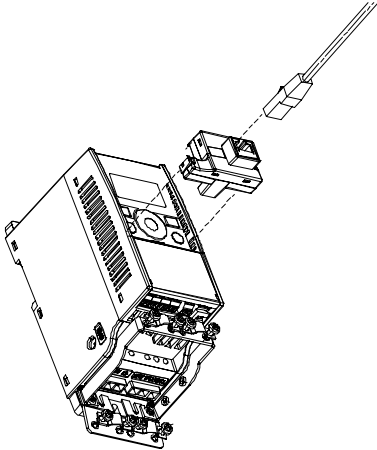
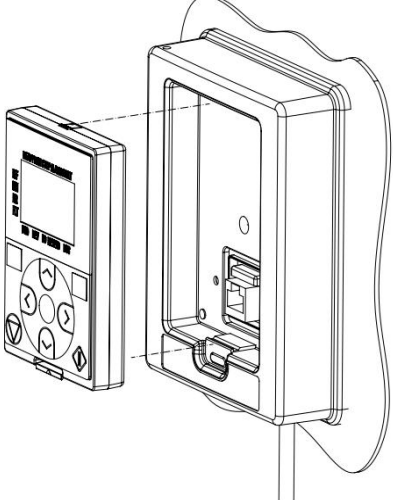
5a	<p>Connect the other end of the data cable to the terminal in the panel base of the AC drive. Then use Cable tie (5) to tie cable to the cut of metal part Cable support (only available for standard drive)</p> <p>Only for standard drive</p> 
5b	<p>Assemble adaptor(3b.) to a cover and UART connector. Connect cable(4.) to adaptor(3b.).</p> <p>Only for compact drive</p> 
6	<p>Assembly text display (2.) to Control panel base (1.).</p> 

Note: All dimensions are dual dimensions in [inches] millimeters

Customer metal plate

