



Quick Guide

VLT[®] AutomationDrive FC 360



Contents

1 Introduction	3
1.1 Purpose of the Manual	3
1.2 Additional Resources	3
1.3 Document and Software Version	3
1.4 Approvals and Certifications	3
1.5 Disposal	3
1.6 Product Overview	3
2 Safety	8
2.1 Safety Symbols	8
2.2 Qualified Personnel	8
2.3 Safety Precautions	8
3 Mechanical Installation	10
3.1 Identification and Variants	10
3.2 Installation Environment	11
3.3 Mounting	11
4 Electrical Installation	13
4.1 General Requirements	13
4.2 EMC-compliant Installation	13
4.3 Grounding Requirements	13
4.4 Wiring Schematic	15
4.5 Mains, Motor, and Ground Connections	17
4.6 Control Wiring	18
4.7 Jumper Terminals 12 and 27	20
4.8 Serial Communication	20
5 Commissioning	21
5.1 Safety Instructions	21
5.2 Applying Power	21
5.3 Hand On/Auto On Mode	21
5.4 Local Control Panel (LCP) Operations	22
5.5 Basic Programming	30
5.6 Checking Motor Rotation	32
5.7 Checking Encoder Rotation	32
5.8 Local-control Test	32
5.9 System Start-up	33
5.10 PROFIBUS	33
5.11 PROFINET	35

6 Applications	37
6.1 Application Selections	37
6.2 Application Examples	42
7 Diagnostics and Troubleshooting	46
7.1 Warning and Alarm Types	46
7.2 Warning and Alarm Displays	46
7.3 Warning and Alarm Code List	47
7.4 Error Code List	51
7.5 Troubleshooting	51
8 Specifications	53
8.1 Mains Supply 3x380–480 V AC	53
8.2 General Technical Data	56
8.3 Fuses	60
8.4 Connection Tightening Torques	61
9 Appendix	62
9.1 Symbols, Abbreviations, and Conventions	62
9.2 Parameter Menu Structure	62
Index	73

1 Introduction

1.1 Purpose of the Manual

The quick guide provides information for safe installation and commissioning of the frequency converter.

The quick guide is intended for use by qualified personnel.

To use the frequency converter safely and professionally, read and follow the quick guide. Pay particular attention to the safety instructions and general warnings. Always keep this quick guide with the frequency converter.

VLT® is a registered trademark.

1.2 Additional Resources

Other resources are available to understand advanced frequency converter functions and programming.

- The *programming guide* provides greater detail on working with parameters.
- The *design guide* provides detailed information about the design and applications of the frequency converter.
- Optional equipment is available that may change some of the procedures described. Be sure to see the instructions supplied with those options for specific requirements.

Contact the local Danfoss supplier for technical documentations.

1.3 Document and Software Version

The quick guide is regularly reviewed and updated. All suggestions for improvement are welcome.

Edition	Remarks	Software version
MG06A7	Update due to new software release.	1.70

1.4 Approvals and Certifications

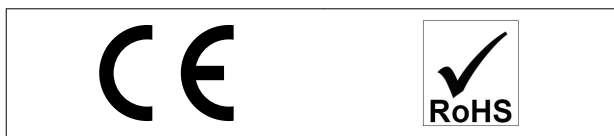

1.5 Disposal

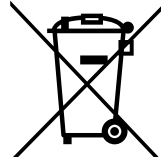

Do not dispose of equipment containing electrical components together with domestic waste.
Collect it separately in accordance with local and currently valid legislation.

1.6 Product Overview

A frequency converter is an electronic motor controller that converts AC mains input into a variable AC waveform output. The frequency and voltage of the output are regulated to control the motor speed or torque. The frequency converter can vary the speed of the motor in response to system feedback, such as changing temperature or pressure for controlling fan, compressor, or pump motors. The frequency converter can also regulate the motor by responding to remote commands from external controllers.

In addition, the frequency converter monitors the system and motor status, issues warnings, or alarms for fault conditions, starts and stops the motor, optimizes energy efficiency, and offers many more control, monitoring, and efficiency functions. Operation and monitoring functions are available as status indications to an outside control system or serial communication network.

1.6.1 Block Diagram of the Frequency Converter

Illustration 1.1 is a block diagram of the internal components of the frequency converter.

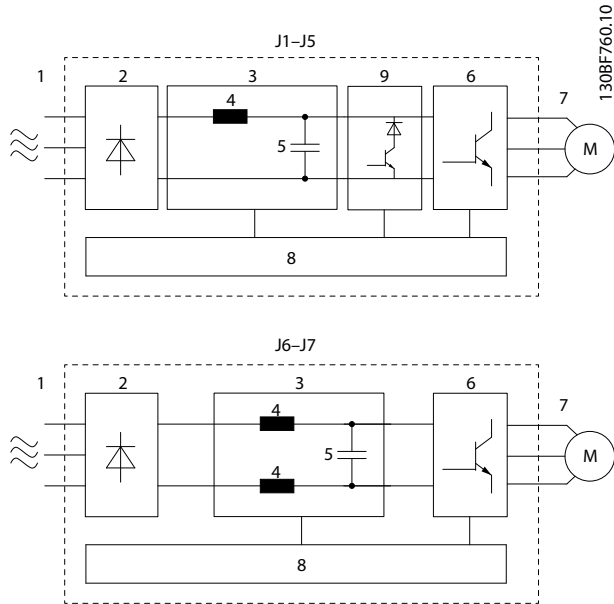

Area	Component	Functions
1	Mains input	<ul style="list-style-type: none"> AC mains supply to the frequency converter.
2	Rectifier	<ul style="list-style-type: none"> The rectifier bridge converts the AC input to DC current to supply inverter power.
3	DC bus	<ul style="list-style-type: none"> Intermediate DC-bus circuit handles the DC current.
4	DC reactor	<ul style="list-style-type: none"> Filters the intermediate DC circuit current. Provides mains transient protection. Reduces the root mean square (RMS) current. Raises the power factor reflected back to the line. Reduces harmonics on the AC input.

Area	Component	Functions
5	Capacitor bank	<ul style="list-style-type: none"> Stores the DC power. Provides ride-through protection for short power losses.
6	Inverter	<ul style="list-style-type: none"> Converts the DC into a controlled PWM AC waveform for a controlled variable output to the motor.
7	Output to motor	<ul style="list-style-type: none"> Regulated 3-phase output power to the motor.
8	Control circuitry	<ul style="list-style-type: none"> Input power, internal processing, output, and motor current are monitored to provide efficient operation and control. User interface and external commands are monitored and performed. Status output and control can be provided.
9	Brake chopper	<ul style="list-style-type: none"> Brake chopper is used in the DC intermediate circuit to control DC voltage when the load feeds energy back.

Illustration 1.1 Example of Block Diagram for a Frequency Converter

1.6.2 Enclosure Sizes and Power Ratings

Enclosure size 380–480 V	J1	J2	J3	J4	J5	J6	J7
Power size [kW (hp)]	0.37–2.2 (0.5–3)	3.0–5.5 (4.0–7.5)	7.5 (10)	11–15 (15–20)	18.5–22 (25–30)	30–45 (40–60)	55–75 (75–100)
Dimensions [mm (in)]							
Height A	210 (8.3)	272.5 (10.7)	272.5 (10.7)	317.5 (12.5)	410 (16.1)	515 (20.3)	550 (21.7)
Width B	75 (3.0)	90 (3.5)	115 (4.5)	133 (5.2)	150 (5.9)	233 (9.2)	308 (12.1)
Depth C	168 (6.6)	168 (6.6)	168 (6.6)	245 (9.6)	245 (9.6)	241 (9.5)	323 (12.7)
Depth C with option B	173 (6.8)	173 (6.8)	173 (6.8)	250 (9.8)	250 (9.8)	–	–
D	180 (7.1)	240 (9.4)	240 (9.4)	270 (10.6)	364.7 (14.4)	452 (17.8)	484.5 (19.0)
Mounting holes							
a	198 (7.8)	260 (10.2)	260 (10.2)	297.5 (11.7)	390 (15.4)	495 (19.5)	521 (20.5)
b	60 (2.4)	70 (2.8)	90 (3.5)	105 (4.1)	120 (4.7)	200 (7.9)	270 (10.6)
Mounting screw	M4	M5	M5	M6	M6	M8	M8

Table 1.1 Enclosure Sizes, Power Ratings, and Dimensions

1.6.3 Exploded Views

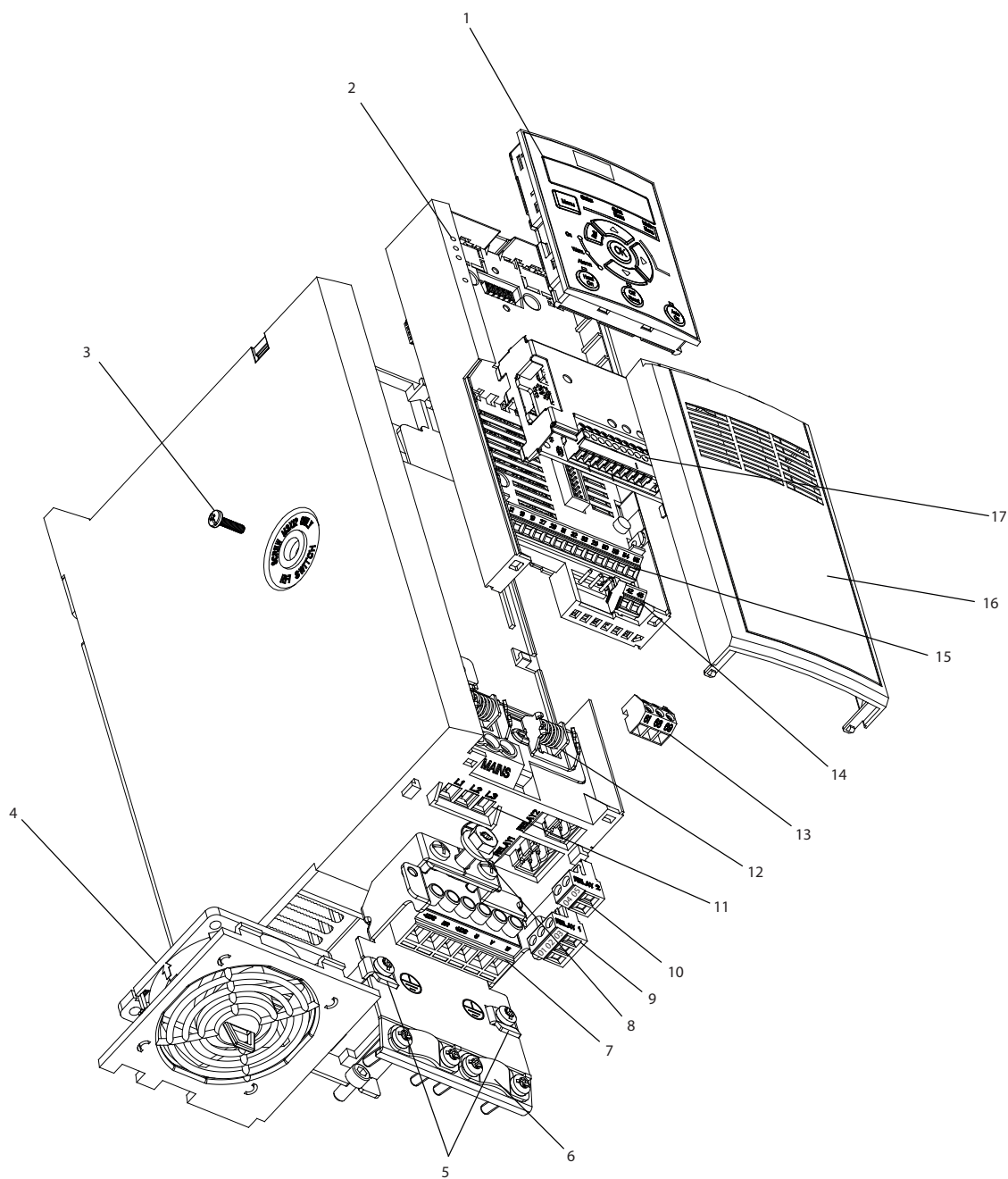

130BC439.11

1	NLCP (accessory)	10	2-pole relay 2 (0.37–7.5 kW/0.5–10 hp), pluggable 3-pole relay 2 (11–22 kW/15–30 hp), pluggable
2	Control cassette	11	Mains terminals
3	RFI switch (screw M3x12 only)	12	Cable strain relief (accessory for 0.37–2.2 kW units)
4	Removable fan assembly	13	Pluggable RS485 terminal
5	Grounding clamp (accessory)	14	Fixed I/O terminals
6	Shielded cable grounding clamp and strain relief (accessory)	15	Fixed I/O terminals
7	Motor terminals (U, V, W), and brake and load sharing terminals	16	Terminal cover
8	PE ground	17	B options (MCB 102/MCB 103 accessories)
9	3-pole relay 1		

Illustration 1.2 Exploded View, J1–J5 (0.37–22 kW/0.5–30 hp), IP20 (Taking J2 as an example)

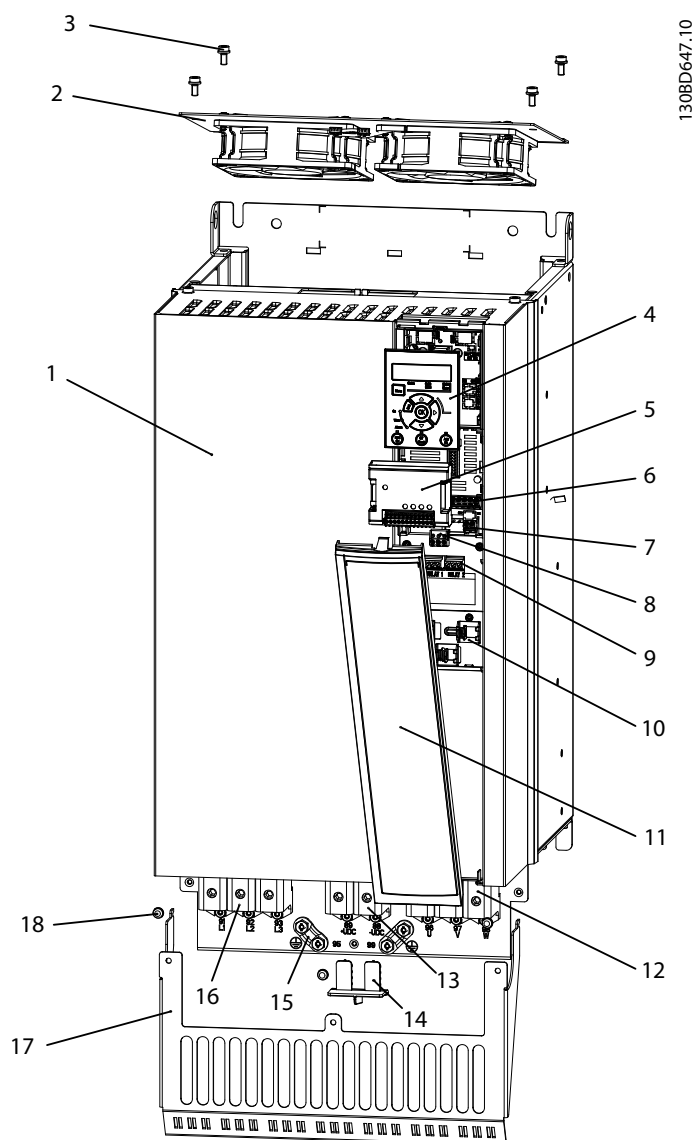

1	J7 frequency converter	10	I/O cable clamps
2	Removable fan assembly	11	Terminal cover
3	M5 screw X4 (for fan assembly)	12	Motor terminals
4	NLCP (accessory)	13	Load sharing terminals
5	B options (MCB 102/MCB 103 accessories)	14	Removable plugger (for load sharing terminal)
6	I/O terminals	15	Shielded cable grounding clamps
7	I/O terminals	16	Mains terminals
8	Pluggable RS485 terminals	17	Decoupling plate (accessory)
9	Relay terminal 1&2, fixed	18	M4 screw X3 (for decoupling plate)

Illustration 1.3 Exploded View, J6–J7 (30–75 kW/40–100 hp), IP20 (Taking J7 as an example)

2

2 Safety

2.1 Safety Symbols

The following symbols are used in this document:

⚠ WARNING

Indicates a potentially hazardous situation that could result in death or serious injury.

⚠ CAUTION

Indicates a potentially hazardous situation that could result in minor or moderate injury. It can also be used to alert against unsafe practices.

NOTICE

Indicates important information, including situations that can result in damage to equipment or property.

2.2 Qualified Personnel

Correct and reliable transport, storage, installation, operation, and maintenance are required for the trouble-free and safe operation of the frequency converter. Only qualified personnel are allowed to install or operate this equipment.

Qualified personnel are defined as trained staff, who are authorized to install, commission, and maintain equipment, systems, and circuits in accordance with pertinent laws and regulations. Also, the personnel must be familiar with the instructions and safety measures described in this guide.

2.3 Safety Precautions

⚠ WARNING

HIGH VOLTAGE

Frequency converters contain high voltage when connected to AC mains input, DC supply, or load sharing. Failure to perform installation, start-up, and maintenance by qualified personnel can result in death or serious injury.

- Only qualified personnel must perform installation, start-up, and maintenance.

⚠ WARNING

UNINTENDED START

When the frequency converter is connected to AC mains, DC supply, or load sharing, the motor may start at any time. Unintended start during programming, service, or repair work can result in death, serious injury, or property damage. Start the motor with an external switch, a fieldbus command, an input reference signal from the local control panel (LCP), via remote operation using MCT 10 software, or after a cleared fault condition.

To prevent unintended motor start:

- Disconnect the frequency converter from the mains.
- Press [Off/Reset] on the LCP before programming parameters.
- Ensure that the frequency converter is fully wired and assembled when it is connected to AC mains, DC supply, or load sharing.

⚠ WARNING

DISCHARGE TIME

The frequency converter contains DC-link capacitors, which can remain charged even when the frequency converter is not powered. High voltage can be present even when the warning LED indicator lights are off. Failure to wait the specified time after power has been removed before performing service or repair work can result in death or serious injury.

- Stop the motor.
- Disconnect AC mains and remote DC-link power supplies, including battery back-ups, UPS, and DC-link connections to other frequency converters.
- Disconnect or lock PM motor.
- Wait for the capacitors to discharge fully. The minimum duration of waiting time is specified in *Table 2.1* and is also visible on the product label on top of the frequency converter.
- Before performing any service or repair work, use an appropriate voltage measuring device to make sure that the capacitors are fully discharged.

Voltage [V]	Power range [kW (hp)]	Minimum waiting time (minutes)
380–480	0.37–7.5 kW (0.5–10 hp)	4
380–480	11–75 kW (15–100 hp)	15

Table 2.1 Discharge Time

⚠ WARNING**LEAKAGE CURRENT HAZARD**

Leakage currents exceed 3.5 mA. Failure to ground the frequency converter properly can result in death or serious injury.

- Ensure the correct grounding of the equipment by a certified electrical installer.

⚠ WARNING**EQUIPMENT HAZARD**

Contact with rotating shafts and electrical equipment can result in death or serious injury.

- Ensure that only trained and qualified personnel perform installation, start-up, and maintenance.
- Ensure that electrical work conforms to national and local electrical codes.
- Follow the procedures in this manual.

NOTICE**HIGH ALTITUDES**

For installation at altitudes above 2000 m (6562 ft), contact Danfoss regarding PELV.

⚠ CAUTION**INTERNAL FAILURE HAZARD**

An internal failure in the frequency converter can result in serious injury when the frequency converter is not properly closed.

- Ensure that all safety covers are in place and securely fastened before applying power.

NOTICE**USE ON ISOLATED MAINS**

For details about the use of the frequency converter on isolated mains, refer to the section *RFI Switch* in the *design guide*.

Follow the recommendations regarding the installation on IT mains. Use relevant monitoring devices for IT mains to avoid damage.

3 Mechanical Installation

3.1 Identification and Variants

3

Confirm that the equipment matches the requirements and ordering information by checking power size, voltage data, and overload data on the nameplate of the frequency converter.

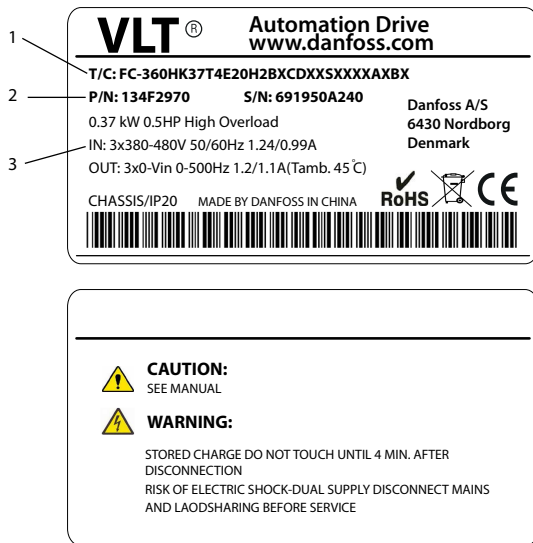

130BC435.12

1	Type code
2	Ordering number
3	Specifications

Illustration 3.1 Nameplates 1 and 2

1-6: Product Name	
7: Overload	H: Heavy duty Q: Normal duty ¹⁾
8-10: Power size	0.37-75 kW (0.5-100 hp). For example: K37: 0.37 kW ²⁾ (0.5 hp) 1K1: 1.1 kW (1.5 hp) 11 K: 11 kW (15 hp)
11-12: Voltage class	T4: 380-480 V 3-phases
13-15: IP class	E20: IP20
16-17: RFI	H2: C3 Class
18: Brake chopper	X: No B: Built-in ³⁾
19: LCP	X: No
20: PCB coating	C: 3C3
21: Mains terminals	D: Load sharing
29-30: Embedded fieldbus	AX: No A0: PROFIBUS AL: PROFINET
31-32: Option B	BX: No option BR: MCB-102 Encoder BU: MCB-103 Resolver

Table 3.1 Type Code: Selection of Different Features and Options

For options and accessories, refer to the section Options and Accessories in the VLT® AutomationDrive FC 360 Design Guide.

1) Only 11-75 kW (15-100 hp) for normal duty variants. PROFIBUS and PROFINET are unavailable for normal duty.

2) For all power sizes, see chapter 8.1.1 Mains Supply 3x380-480 V AC.

3) 0.37-22 kW (0.5-30 hp) with built-in brake chopper. 30-75 kW (40-100 hp) with external brake chopper only.

1	2	3	4	5	6	7	8	9	10	11	12	13	14	15	16	17	18	19	20	21	22	23	24	25	26	27	28	29	30	31	32
F	C	-	3	6	0	H				T	4	E	2	0	H	2	X	X	C	D	X	X	S	X	X	X	X	A	X	B	X
						Q											B											A	0		
																												A	L		

130BC437.10

Illustration 3.2 Type Code String

3.2 Installation Environment

NOTICE

REDUCED LIFETIME

In environments with airborne liquids, particles, or corrosive gases, ensure that the IP/Type rating of the equipment matches the installation environment. Failure to meet requirements for ambient conditions can reduce lifetime of the frequency converter.

- Ensure that requirements for air humidity, temperature, and altitude are met.

Vibration and shock

The frequency converter complies with requirements for units mounted on the walls and floors of production premises, and in panels bolted to walls or floors.

For detailed ambient conditions specifications, refer to chapter 8.2 General Technical Data.

3.3 Mounting

Select the best possible operation site by considering:

- Ambient operating temperature.
- Installation method.
- Cooling.
- Position of the frequency converter.
- Cable routing.
- Power source supplying correct voltage and necessary current.
- Motor current rating within the maximum current from the frequency converter.
- Correct rating of external fuses and circuit breakers.

Cooling and mounting:

- Provide top and bottom clearance for air cooling, see Table 3.2 for clearance requirements.
- Consider derating for temperatures starting from 45 °C (113 °F) and elevation 1000 m (3281 ft) above sea level. See the design guide for details on derating.

Enclosure size	J1–J5	J6 and J7
Clearance above and below the unit [mm (in)]	100 (3.94)	200 (7.87)

Table 3.2 Minimum Airflow Clearance Requirements

- Mount the unit vertically.
- IP20 units allow side-by-side installation.
- Improper mounting can result in overheating and reduced performance.
- Use the slotted mounting holes on the unit for wall mount, when provided.
- See chapter 8.4 Connection Tightening Torques for proper tightening specifications.

3.3.1 Side-by-side Installation

All VLT® AutomationDrive FC 360 units can be installed side by side in vertical position. The units do not require extra ventilation on the side.

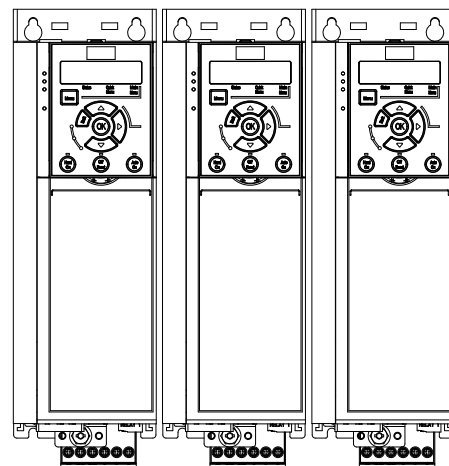

Illustration 3.3 Side-by-side Installation

130BF792.10

3.3.2 Horizontal Mounting

Enclosure size J1–J5 of VLT® AutomationDrive FC 360 units can be installed in horizontal position.

3

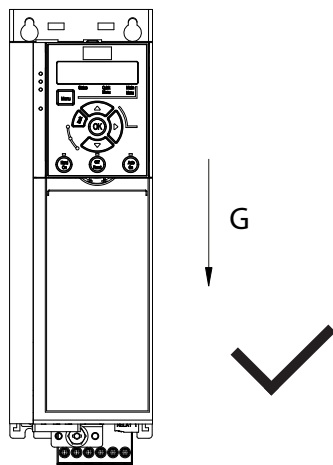

1308F793.10

Illustration 3.4 Normal Mounting

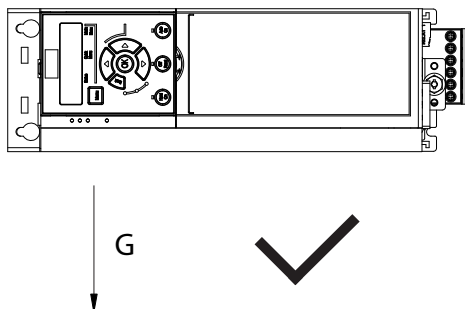

1308F794.10

Illustration 3.5 Correct Horizontal Mounting (Left Side Downwards)

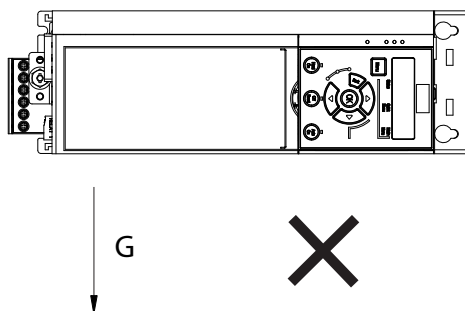

1308F795.10

Illustration 3.6 Incorrect Horizontal Mounting (Right Side Downwards)

4 Electrical Installation

4.1 General Requirements

⚠ WARNING

EQUIPMENT HAZARD

Rotating shafts and electrical equipment can be hazardous. It is important to protect against electrical hazards when applying power to the unit. All electrical work must conform to national and local electrical codes. Installation, start up, and maintenance must be performed only by trained and qualified personnel. Failure to follow these guidelines could result in death or serious injury.

⚠ WARNING

WIRING ISOLATION

Run input power, motor wiring, and control wiring in 3 separate metallic conduits, or use separated shielded cable for high frequency noise isolation. Failure to isolate power, motor, and control wiring could result in less than optimum frequency converter and associated equipment performance.

Run motor cables from multiple frequency converters separately. Induced voltage from output motor cables run together can charge equipment capacitors even with the equipment turned off and locked out. Failure to run output motor cables separately or use shielded cables could result in death or serious injury.

- Run output motor cables separately.
- Use shielded cables.
- Lock out all the frequency converters simultaneously.

Wire type and ratings

- All wiring must comply with local and national regulations regarding cross-section and ambient temperature requirements.
- Danfoss recommends that all power connections are made with a minimum 75 °C (167 °F) rated copper wire.
- See *chapter 8 Specifications* for recommended wire sizes.

⚠ WARNING

SHOCK HAZARD

The frequency converter can cause a DC current in the PE conductor and hence result in death or serious injury.

- When a residual current-operated protective device (RCD) is used for protection against electrical shock, only an RCD of Type B is allowed on the supply side.

Failure to follow the recommendation means that the RCD cannot provide the intended protection.

Overcurrent protection

- Extra protective equipment such as short-circuit protection or motor thermal protection between frequency converter and motor is required for applications with multiple motors.
- Input fusing is required to provide protection against short circuit and overcurrent. If fuses are not factory-supplied, the installer must provide them. See maximum fuse ratings in *chapter 8.3 Fuses*.

4.2 EMC-compliant Installation

To obtain an EMC-compliant installation, follow the instructions provided in *chapter 4.3 Grounding Requirements*, *chapter 4.4 Wiring Schematic*, *chapter 4.5 Mains, Motor, and Ground Connections*, and *chapter 4.6 Control Wiring*.

4.3 Grounding Requirements

⚠ WARNING

GROUNDING HAZARD

For operator safety, a certified electrical installer should ground the frequency converter in accordance with national and local electrical codes and instructions contained within this manual. Ground currents are higher than 3.5 mA. Failure to ground the frequency converter properly could result in death or serious injury.

- Proper protective grounding for equipment with ground currents higher than 3.5 mA must be established.
- A dedicated ground wire is required for input power, motor power, and control wiring.
- Use the clamps provided with the equipment for proper ground connections.
- Do not ground 1 frequency converter to another in a daisy chain fashion (see *Illustration 4.1*).

4

- Keep the ground wire connections as short as possible.
- Use high-strand wire to reduce electrical noise.
- Follow motor manufacturer wiring requirements.

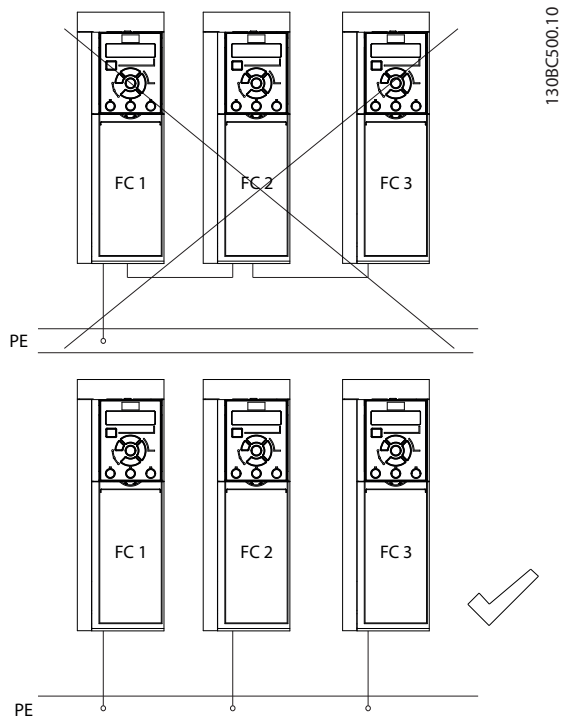

Illustration 4.1 Grounding Principle

4.4 Wiring Schematic

This section describes how to wire the frequency converter.

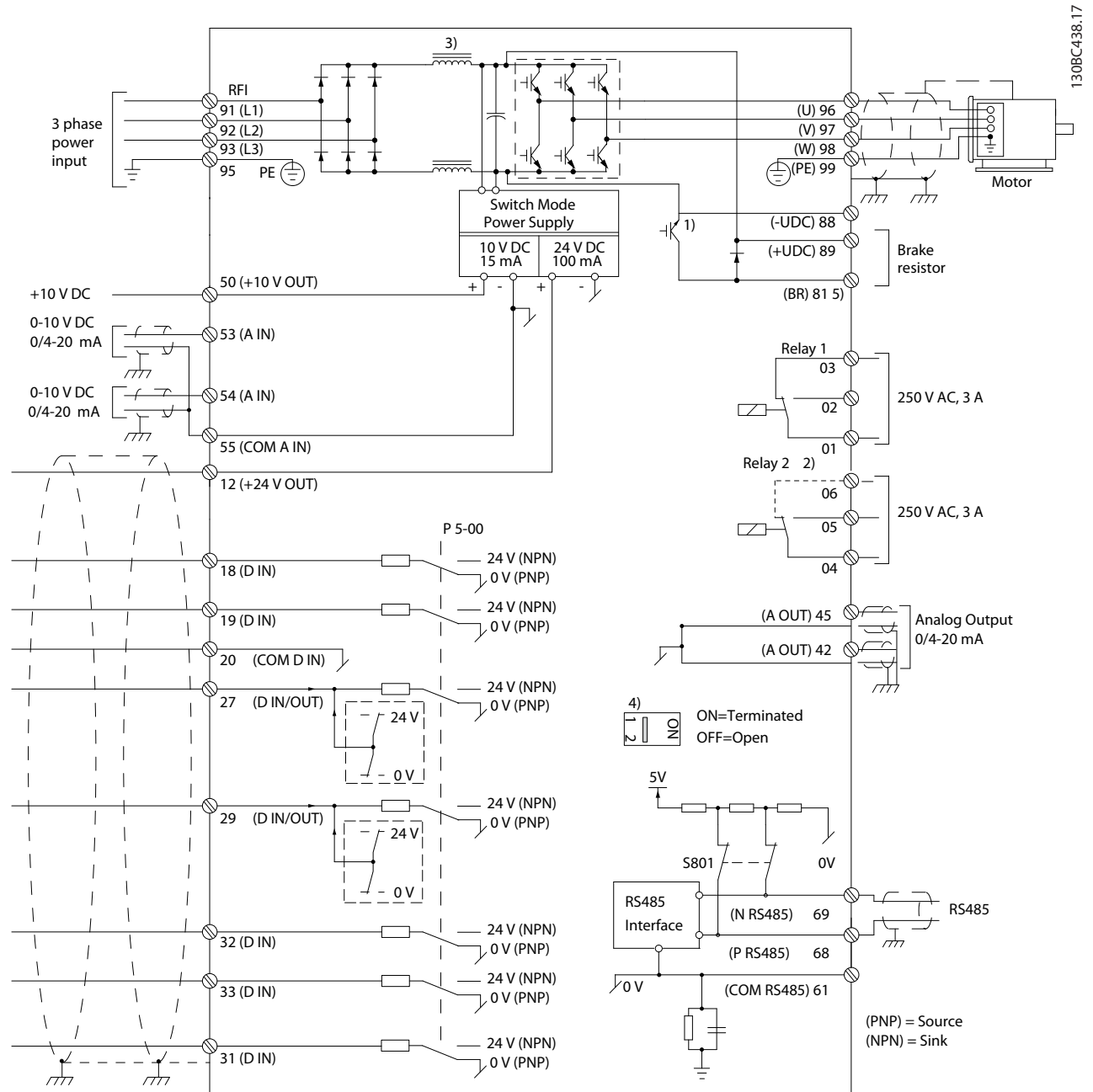
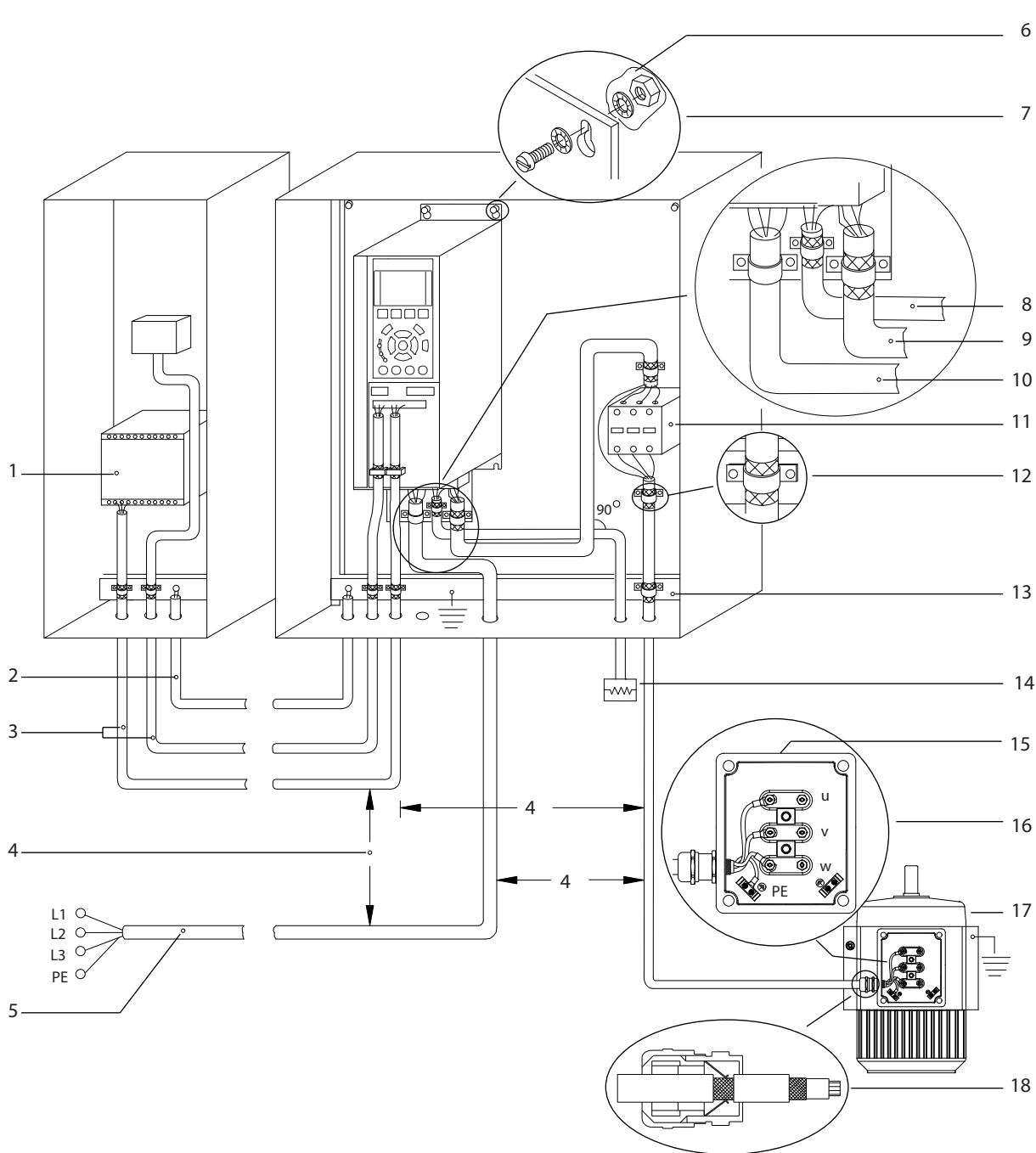

Illustration 4.2 Basic Wiring Schematic Drawing

A=Analog, D=Digital

- 1) Built-in brake chopper available from J1-J5.
- 2) Relay 2 is 2-pole for J1-J3 and 3-pole for J4-J7. Relay 2 of J4-J7 with terminals 4, 5, and 6 has same NO/NC logic as relay 1. Relays are pluggable in J1-J5, and fixed in J6-J7.
- 3) Single DC choke in J1-J5; Dual DC choke in J6-J7.
- 4) Switch S801 (bus terminal) can be used to enable termination on the RS485 port (terminals 68 and 69).
- 5) No BR for J6-J7.

4



1.30BF228.10

1	PLC	10	Mains cable (unshielded)
2	Minimum 16 mm ² (6 AWG) equalizing cable	11	Output contactor, and more.
3	Control cables	12	Cable insulation stripped
4	Minimum 200 mm (7.87 in) between control cables, motor cables, and mains cables.	13	Common ground busbar. Follow local and national requirements for cabinet grounding.
5	Mains supply	14	Brake resistor
6	Bare (unpainted) surface	15	Metal box
7	Star washers	16	Connection to motor
8	Brake cable (shielded)	17	Motor
9	Motor cable (shielded)	18	EMC cable gland

Illustration 4.3 Typical Electrical Connection

4.5 Mains, Motor, and Ground Connections

⚠ WARNING

INDUCED VOLTAGE

Run output motor cables from multiple frequency converters separately. Induced voltage from output motor cables run together can charge equipment capacitors even when the equipment is turned off and locked out. Failure to run output motor cables separately could result in death or serious injury.

Grounding clamps are provided for motor wiring (see *Illustration 4.4*).

- Do not install power factor correction capacitors between the frequency converter and the motor.
- Do not wire a starting or pole-changing device between the frequency converter and the motor.
- Follow motor manufacturer wiring requirements.
- All frequency converters must be used with an isolated input source and with ground reference power lines. When supplied from an isolated mains source (IT mains or floating delta) or TT/TN-S mains with a grounded leg (grounded delta), set *parameter 14-50 RFI Filter* to OFF (enclosure sizes J6–J7) or remove the RFI screw (enclosure sizes J1–J5). When off, the internal RFI filter capacitors between the chassis and the intermediate circuit are isolated to avoid damage to the intermediate circuit and reduce ground capacity currents in accordance with IEC 61800-3.
- Do not install a switch between the frequency converter and the motor in IT mains.

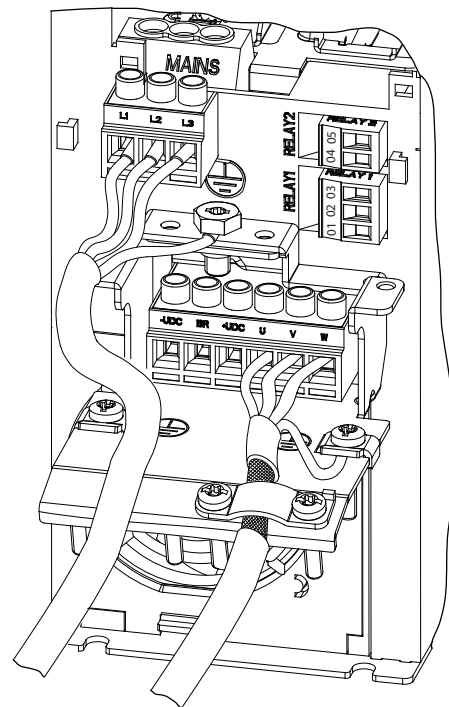

Illustration 4.4 Mains, Motor, and Ground Connections for Enclosure Sizes J1–J5 (Taking J2 as an example)

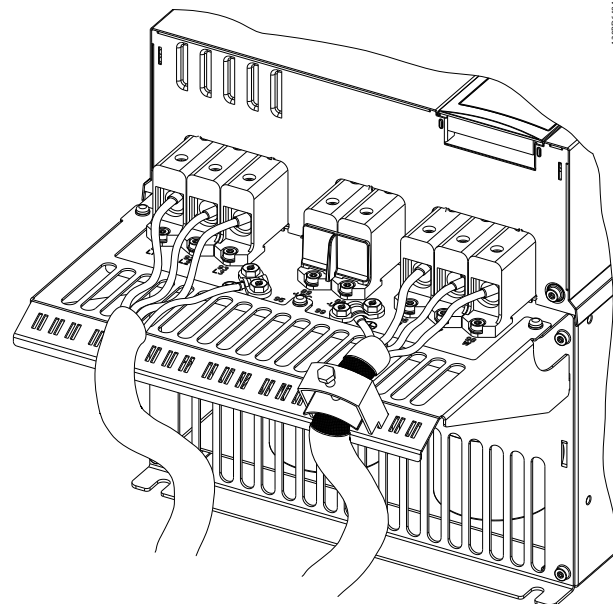

Illustration 4.5 Mains, Motor, and Ground Connections for Enclosure Size J6–J7 (Taking J7 as an example)

Illustration 4.4 shows mains input, motor, and grounding for enclosure sizes J1–J5. *Illustration 4.5* shows mains input, motor, and grounding for enclosure size J6–J7. Actual configurations vary with unit types and optional equipment.

4.6 Control Wiring

Access

- Remove the cover plate with a screwdriver. See *Illustration 4.6*.

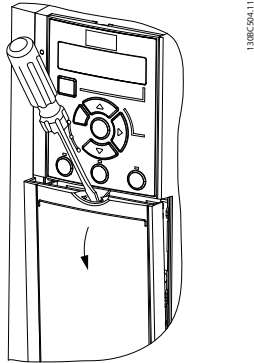

Illustration 4.6 Control Wiring Access for Enclosure Sizes J1-J7

Control terminal types

Illustration 4.7 shows the frequency converter control terminals. Terminal functions and default settings are summarized in *Table 4.1*.

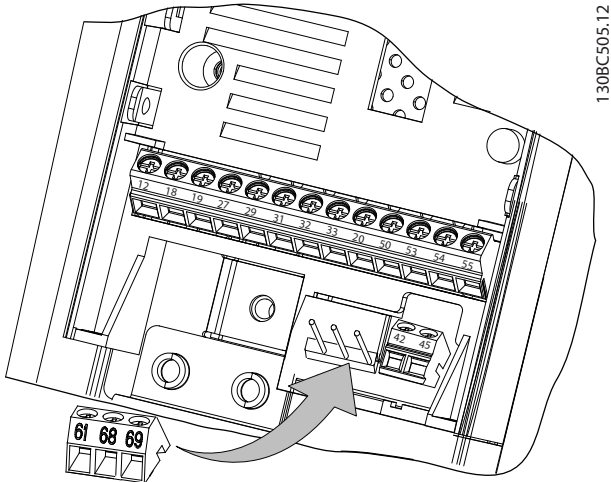

Illustration 4.7 Control Terminal Locations

See *chapter 8.2 General Technical Data* for terminal ratings details.

Terminal	Parameter	Default setting	Description
Digital I/O, pulse I/O, encoder			
12	-	+24 V DC	24 V DC supply voltage. Maximum output current is 100 mA for all 24 V loads.

Terminal	Parameter	Default setting	Description
18	Parameter 5-10 Terminal 18 Digital Input	[8] Start	Digital inputs.
19	Parameter 5-11 Terminal 19 Digital Input	[10] Reversing	
31	Parameter 5-16 Terminal 31 Digital Input	[0] No operation	
32	Parameter 5-14 Terminal 32 Digital Input	[0] No operation	Digital input, 24 V encoder. Terminal 33 can be used for pulse input.
33	Parameter 5-15 Terminal 33 Digital Input	[16] Preset ref bit 0	
27	Parameter 5-12 Terminal 27 Digital Input parameter 5-30 Terminal 27 Digital Output	DI [2] Coast inverse DO [0] No operation	Selectable for either digital input, digital output, or pulse output. Default setting is digital input.
29	Parameter 5-13 Terminal 29 Digital Input parameter 5-31 Terminal 29 Digital Output	DI [14] Jog DO [0] No operation	Terminal 29 can be used for pulse input.
20	-	-	Common for digital inputs and 0 V potential for 24 V supply.
Analog inputs/outputs			
42	Parameter 6-91 Terminal 42 Analog Output	[0] No operation	Programmable analog output. The analog signal is 0-20 mA or 4-20 mA at a maximum of 500 Ω. Can also be configured as digital outputs
45	Parameter 6-71 Terminal 45 Analog Output	[0] No operation	
50	-	+10 V DC	10 V DC analog supply voltage. 15 mA maximum commonly used for potentiometer or thermistor.

Terminal	Parameter	Default setting	Description
53	Parameter group 6-1* Analog Input 53	-	Analog input. Selectable for voltage or current.
54	Parameter group 6-2* Analog Input 54	-	Analog input. Selectable for voltage or current.
55	-	-	Common for analog input
Serial communication			
61	-	-	Integrated RC-filter for cable shield. ONLY for connecting the shield when experiencing EMC problems.
68 (+)	Parameter group 8-3* FC Port Settings	-	RS485 interface. A control card switch is provided for termination resistance.
69 (-)	Parameter group 8-3* FC Port Settings	-	RS485 interface. A control card switch is provided for termination resistance.
Relays			
01, 02, 03	5-40 [0]	[9] Alarm	Form C relay output. These relays are in various locations depending on the frequency converter configuration and size. Usable for AC or DC voltage and resistive or inductive loads. RO2 in J1-J3 enclosure is 2-pole, only terminals 04 and 05 are available
04, 05, 06	5-40 [1]	[5] Running	Form C relay output. These relays are in various locations depending on the frequency converter configuration and size. Usable for AC or DC voltage and resistive or inductive loads. RO2 in J1-J3 enclosure is 2-pole, only terminals 04 and 05 are available

Table 4.1 Terminal Descriptions

Control terminal functions

Frequency converter functions are commanded by receiving control input signals.

- Program each terminal for the function it supports in the parameters associated with that terminal.
- Confirm that the control terminal is programmed for the correct function. See *chapter 5 Commissioning* for details on accessing parameters and programming.

- The default terminal programming initiates frequency converter functioning in a typical operational mode.

Using shielded control cables

The preferred method in most cases is to secure control and serial communication cables with shielding clamps provided at both ends to ensure the best possible high frequency cable contact.

If the ground potential between the frequency converter and the PLC is different, electric noise could disturb the entire system. Solve this problem by fitting an equalizing cable as close as possible to the control cable. Minimum cable cross-section: 16 mm² (6 AWG).

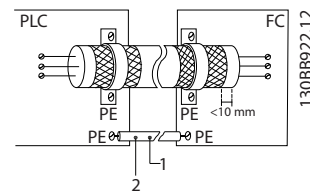

1	Minimum 16 mm ² (6 AWG)
2	Equalizing cable

Illustration 4.8 Shielding Clamps at Both Ends

50/60 Hz ground loops

With long control cables, ground loops could occur. To eliminate ground loops, connect 1 end of the shield to the ground with a 100 nF capacitor (keeping leads short).

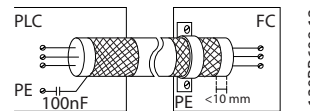
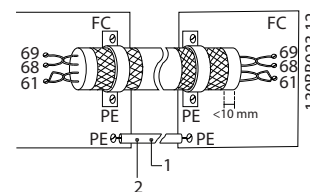

Illustration 4.9 Connection with a 100 nF Capacitor

Avoid EMC noise on serial communication

This terminal is connected to ground via an internal RC link. Use twisted-pair cables to reduce interference between conductors. The recommended method is shown in *Illustration 4.10*.



1	Minimum 16 mm ² (6 AWG)
2	Equalizing cable

Illustration 4.10 Twisted-pair Cables

Alternatively, the connection to terminal 61 can be omitted.

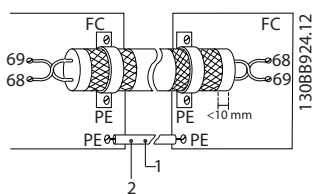

1	Minimum 16 mm ² (6 AWG)
2	Equalizing cable

Illustration 4.11 Twisted-pair Cables without Terminal 61

4.7 Jumper Terminals 12 and 27

When the factory default programming values are used, connect a jumper wire between terminal 12 and terminal 27 for the frequency converter to operate.

- Digital input terminal 27 is designed to receive a 24 V DC coast command. In many applications, wire a coast device to terminal 27.
- When no interlock device is used, wire a jumper between control terminal 12 and terminal 27. This provides internal 24 V signal on terminal 27.
- No signal present prevents the unit from operating.
- Only for GLCP: When the status line at the bottom of the LCP reads *AUTO REMOTE COAST*, it indicates that the unit is ready to operate but is missing an input signal on terminal 27.

4.8 Serial Communication

Connect RS485 serial communication wiring to terminals (+) 68 and (-) 69.

- Shielded serial communication cable is recommended.
- See *chapter 4.3.1 Grounding Requirements* for proper grounding.

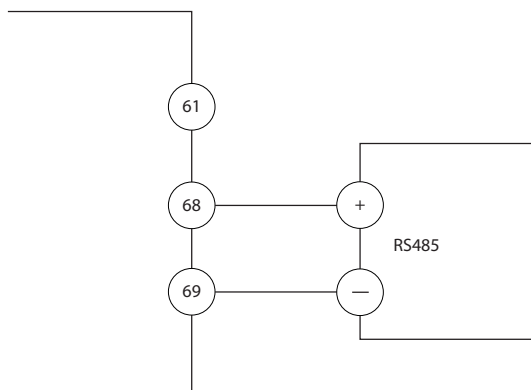

Illustration 4.12 Serial Communication Wiring Diagram

For basic serial communication set-up, select the following:

1. Protocol type in *parameter 8-30 Protocol*.
2. Frequency converter address in *parameter 8-31 Address*.
3. Baud rate in *parameter 8-32 Baud Rate*.

Two communication protocols are internal to the frequency converter.

- Danfoss FC
- Modbus RTU

Follow motor manufacturer wiring requirements.

Functions can be programmed remotely using the protocol software and RS485 connection, or in *parameter group 8-*** Communications and Options*.

Selecting a specific communication protocol changes various default parameter settings to match the specifications of the protocol and makes extra protocol-specific parameters available.

5 Commissioning

5.1 Safety Instructions

See *chapter 2 Safety* for general safety instructions.

WARNING

HIGH VOLTAGE

Frequency converters contain high voltage when connected to AC mains input power. Failure to perform installation, start-up, and maintenance by qualified personnel could result in death or serious injury.

- Installation, start-up, and maintenance must be performed by qualified personnel only.

Before applying power:

1. Close the cover properly.
2. Check that all cable glands are firmly tightened.
3. Ensure that input power to the unit is off and locked out. Do not rely on the frequency converter disconnect switches for input power isolation.
4. Verify that there is no voltage on input terminals L1 (91), L2 (92), and L3 (93), phase-to-phase, and phase-to-ground.
5. Verify that there is no voltage on output terminals 96 (U), 97 (V), and 98 (W), phase-to-phase, and phase-to-ground.
6. Confirm continuity of the motor by measuring Ω values on U-V (96-97), V-W (97-98), and W-U (98-96).
7. Check for proper grounding of the frequency converter and the motor.
8. Inspect the frequency converter for loose connections on the terminals.
9. Confirm that the supply voltage matches the voltage of the frequency converter and the motor.

5.2 Applying Power

Apply power to the frequency converter using the following steps:

1. Confirm that the input voltage is balanced within 3%. If not, correct the input voltage imbalance before proceeding. Repeat this procedure after the voltage correction.
2. Ensure that any optional equipment wiring matches the installation application.

3. Ensure that all operator devices are in the OFF position. Panel doors must be closed and covers securely fastened.
4. Apply power to the unit. Do not start the frequency converter now. For units with a disconnect switch, turn it to the ON position to apply power to the frequency converter.

5.3 Hand On/Auto On Mode

After installation, there are 2 simple ways to start up the frequency converter:

- Hand-on mode
- Auto-on mode

At the first power-up, it is in auto-on mode.

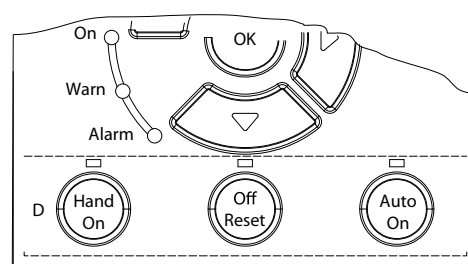

Illustration 5.1 Location of Hand On, Off/Reset, and Auto On Keys on the NLCP

- Press [Hand On] to provide a local start command to the frequency converter. Press [\blacktriangle] and [\blacktriangledown] to increase and decrease speed.
- Press [Off/Reset] to stop the frequency converter.
- Press [Auto On] to control the frequency converter either via control terminals or bus communication.

CAUTION

Since the frequency converter is in auto-on mode at the first power-up, the frequency converter may start the motor directly when the start command is valid via terminals or bus.

NOTICE

Parameter 5-12 Terminal 27 Digital Input has coast inverse as default setting. Connect terminals 12 and 27 to test Hand On/Auto On running.

5.4 Local Control Panel (LCP) Operations

VLT® AutomationDrive FC 360 supports numerical local control panel (NLCP) LCP 21, graphic local control panel (GLCP) LCP 102, and blind cover. This chapter describes the operations with LCP 21 and LCP 102.

NOTICE

The frequency converter can also be programmed from the MCT-10 Set-up Software on PC via RS485 com-port. This software can be ordered using code number 130B1000 or downloaded from the Danfoss website: www.danfoss.com/BusinessAreas/DrivesSolutions/software-download.

5

5.4.1 Numerical Local Control Panel

The numerical local control panel LCP 21 is divided into 4 functional sections.

- A. Numeric display.
- B. Menu key.
- C. Navigation keys and indicator lights (LEDs).
- D. Operation keys and indicator lights (LEDs).

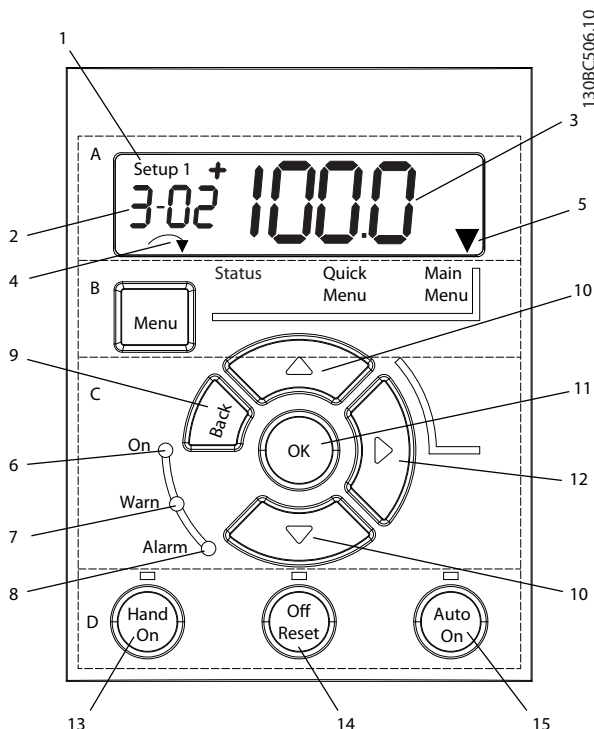

Illustration 5.2 View of the LCP 21

A. Numeric display

The LCD display is backlit with 1 numeric line. All data is shown in the LCP.

1	The set-up number shows the active set-up and the edit set-up. If the same set-up acts as both active and edit set-up, only that set-up number is shown (factory setting). When active and edit set-ups differ, both numbers are shown in the display (set-up 12). The number flashing indicates the edit set-up.
2	Parameter number.
3	Parameter value.
4	Motor direction is shown at the bottom left of the display. A small arrow indicates the direction.
5	The triangle indicates whether the LCP is in Status, Quick Menu, or Main Menu.

Table 5.1 Legend to Illustration 5.2, Section A



Illustration 5.3 Display Information

B. Menu key

To select between Status, Quick Menu, or Main Menu, press [Menu].

C. Indicator lights (LEDs) and navigation keys

	Indicator	Light	Function
6	On	Green	ON turns on when the frequency converter receives power from the mains voltage, a DC bus terminal, or a 24 V external supply.
7	Warn	Yellow	When warning conditions are met, the yellow WARN LED turns on, and text appears in the display area identifying the problem.
8	Alarm	Red	A fault condition causes the red alarm LED to flash and an alarm text is shown.

Table 5.2 Legend to Illustration 5.2, Indicator Lights (LEDs)

	Key	Function
9	[Back]	For moving to the previous step or layer in the navigation structure.
10	[▲] [▼]	For switching between parameter groups, parameters, and within parameters, or increasing/decreasing parameter values. Arrows can also be used for setting local reference.
11	[OK]	Press to access parameter groups or to enable a selection.
12	[▶]	Press to move from left to right within the parameter value to change each digit individually.

Table 5.3 Legend to *Illustration 5.2, Navigation Keys*

D. Operation keys and indicator lights (LEDs)

	Key	Function
13	Hand On	Starts the frequency converter in local control. <ul style="list-style-type: none"> An external stop signal by control input or serial communication overrides the local hand on.
14	Off/Reset	Stops the motor but does not remove power to the frequency converter, or resets the frequency converter manually after a fault has been cleared. If in alarm mode, the alarm is reset if the alarm condition is removed.
15	Auto On	Puts the system in remote operational mode. <ul style="list-style-type: none"> Responds to an external start command by control terminals or bus communication.

Table 5.4 Legend to *Illustration 5.2, Section D*

⚠ WARNING

HIGH VOLTAGE

Touching the frequency converter after pressing the [Off/Reset] key is still dangerous, because the key does not disconnect the frequency converter from the mains.

- Disconnect the frequency converter from the mains and wait for the frequency converter to fully discharge. See the discharge time in *Table 2.1*.

5.4.2 The Right-key Function on NLCP

Press [▶] to edit any of the 4 digits on the display individually. When pressing [▶] once, the cursor moves to the first digit and the digit starts flashing as shown in *Illustration 5.4*. Press the [▲] [▼] to change the value. Pressing [▶] does not change the value of the digits or move the decimal point.

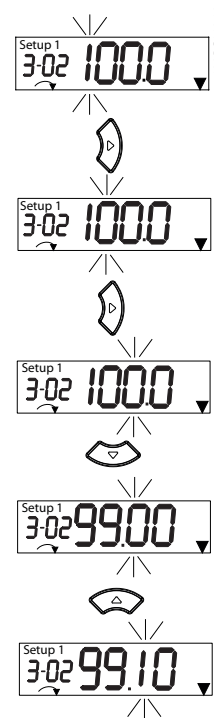

Illustration 5.4 Right-key Function

[▶] can also be used for moving between parameter groups. When in *Main Menu*, press [▶] to move to the first parameter in the next parameter group (for example, move from *parameter 0-03 Regional Settings [0] International* to *parameter 1-00 Configuration Mode [0] Open loop*).

5.4.3 Quick Menu on NLCP

The *Quick Menu* gives easy access to the most frequently used parameters.

- To enter *Quick Menu*, press [Menu] until the indicator in display is placed above *Quick Menu*.
- Press [▲] [▼] to select either QM1 or QM2, then press [OK].
- Press [▲] [▼] to browse through the parameters in *Quick Menu*.
- Press [OK] to select a parameter.
- Press [▲] [▼] to change the value of a parameter setting.
- Press [OK] to accept the change.
- To exit, press either [Back] twice (or 3 times if in QM2 and QM3) to enter *Status*, or press [Menu] once to enter *Main Menu*.

130BC445.12

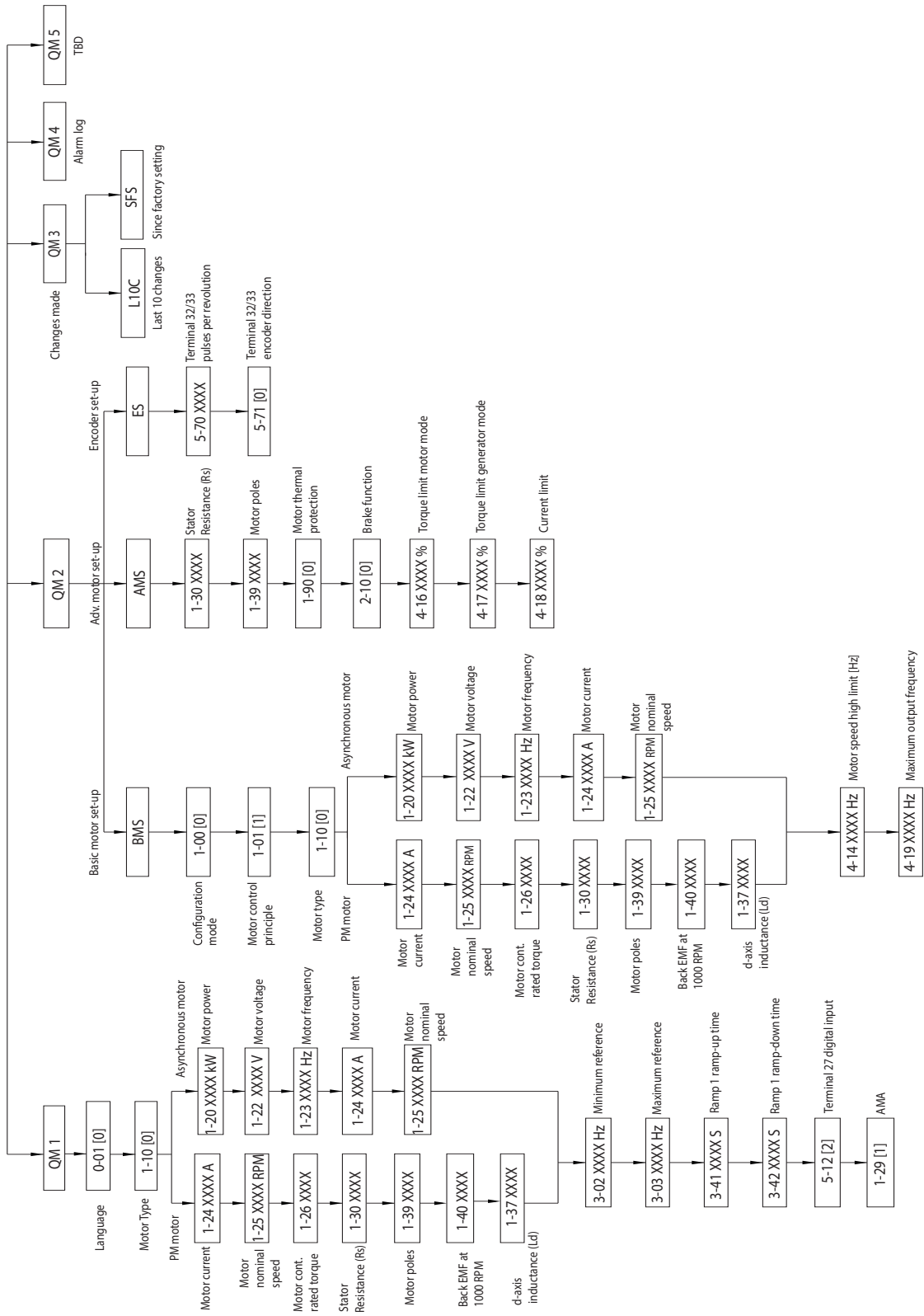

Illustration 5.5 Quick Menu Structure

5.4.4 Status Menu on NLCP

After power-up, Status Menu is active. Press [Menu] to toggle between *Status*, *Quick Menu*, and *Main Menu*.

[▲] and [▼] toggle between the options in each menu.

The display indicates the status mode with a small arrow above *Status*.

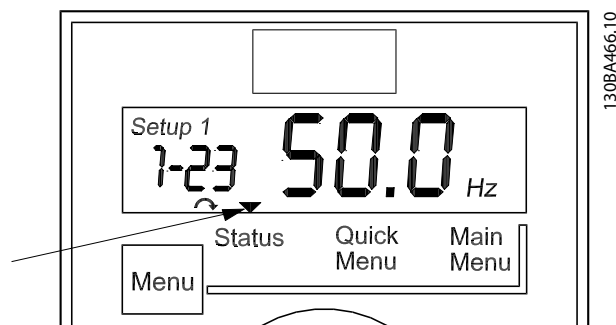

Illustration 5.6 Indicating Status Mode

The following 8 parameters can be accessed from NLCP status menu in auto-on mode:

- Parameter 16-02 Reference [%].
- Parameter 16-09 Custom Readout.
- Parameter 16-10 Power [kW].
- Parameter 16-13 Frequency.
- Parameter 16-14 Motor current.
- Parameter 16-16 Torque [Nm].
- Parameter 16-30 DC Link Voltage.
- Parameter 16-52 Feedback[Unit].

The following 6 parameters can be accessed from NLCP status menu in [Hand On] mode:

- Parameter 16-09 Custom Readout.
- Parameter 16-10 Power [kW].
- Parameter 16-13 Frequency.
- Parameter 16-14 Motor current.
- Parameter 16-16 Torque [Nm].
- Parameter 16-30 DC Link Voltage.

5.4.5 Main Menu on NLCP

The *Main Menu* gives access to all parameters.

1. To enter *Main Menu*, press [Menu] until the indicator in the display is placed above *Main Menu*.
2. [▲] [▼]: Browse through the parameter groups.
3. Press [OK] to select a parameter group.
4. [▲] [▼]: Browse through the parameters in the specific group.
5. Press [OK] to select the parameter.
6. [▶] and [▲] [▼]: Set/change the parameter value.
7. Press [OK] to accept the value.
8. To exit, press either [Back] twice (or 3 times for array parameters) to enter *Main Menu*, or press [Menu] once to enter *Status*.

See *Illustration 5.7*, *Illustration 5.8*, and *Illustration 5.9* for the principles of changing the value of continuous, enumerated, and array parameters, respectively. The actions in the illustrations are described in *Table 5.5*, *Table 5.6*, and *Table 5.7*.

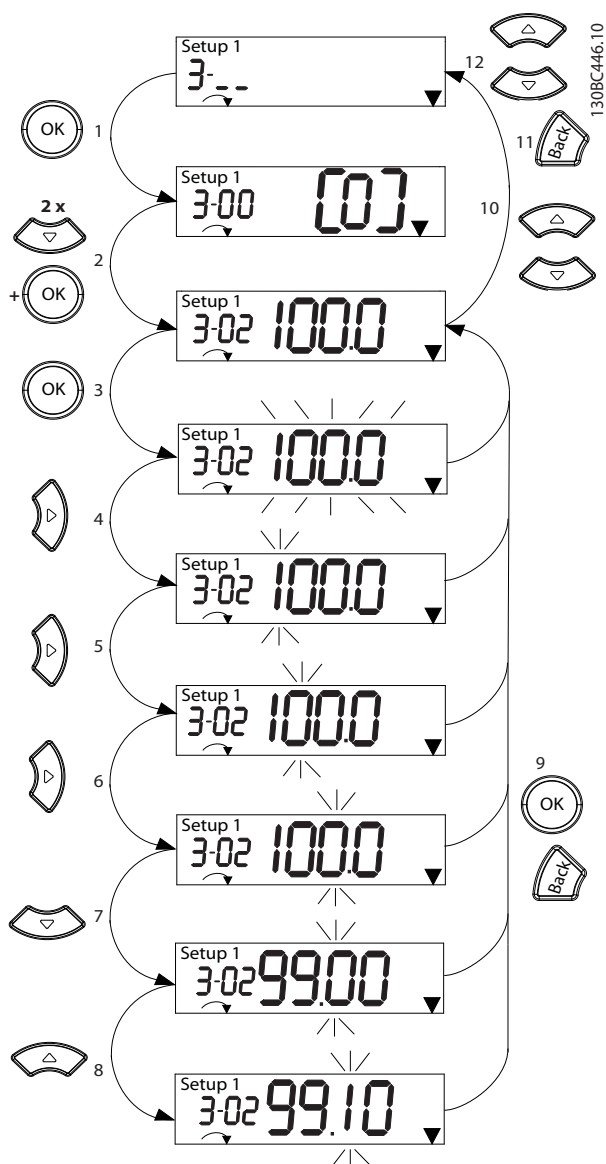

Illustration 5.7 Main Menu Interactions - Continuous Parameters

1	[OK]: The first parameter in the group is shown.
2	Press [▼] repeatedly to move down to the parameter.
3	Press [OK] to start editing.
4	[▶]: First digit flashing (can be edited).
5	[▶]: Second digit flashing (can be edited).
6	[▶]: Third digit flashing (can be edited).
7	[▼]: Decreases the parameter value, the decimal point changes automatically.
8	[▲]: Increases the parameter value.
9	[Back]: Cancel changes, return to 2. [OK]: Accept changes, return to 2.
10	[▲][▼]: Select parameter within the group.
11	[Back]: Removes the value and shows the parameter group.
12	[▲][▼]: Select group.

Table 5.5 Changing Values in Continuous Parameters

For enumerated parameters, the interaction is similar, but the parameter value is shown in brackets because of the LCP 21 digits limitation (4 large digits), and the enum can be greater than 99. When the enum value is greater than 99, the LCP 21 can only show the first part of the bracket.

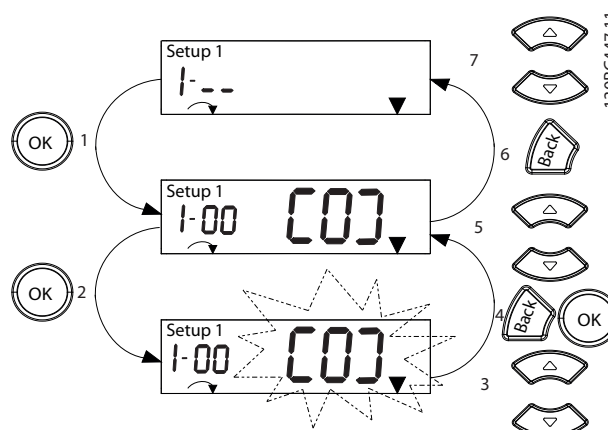

Illustration 5.8 Main Menu Interactions - Enumerated Parameters

1	[OK]: The first parameter in the group is shown.
2	Press [OK] to start editing.
3	[▲][▼]: Change parameter value (flashing).
4	Press [Back] to cancel changes or [OK] to accept changes (return to screen 2).
5	[▲][▼]: Select a parameter within the group.
6	[Back]: Removes the value and shows the parameter group.
7	[▲][▼]: Select a group.

Table 5.6 Changing Values in Enumerated Parameters

Array parameters function as follows:

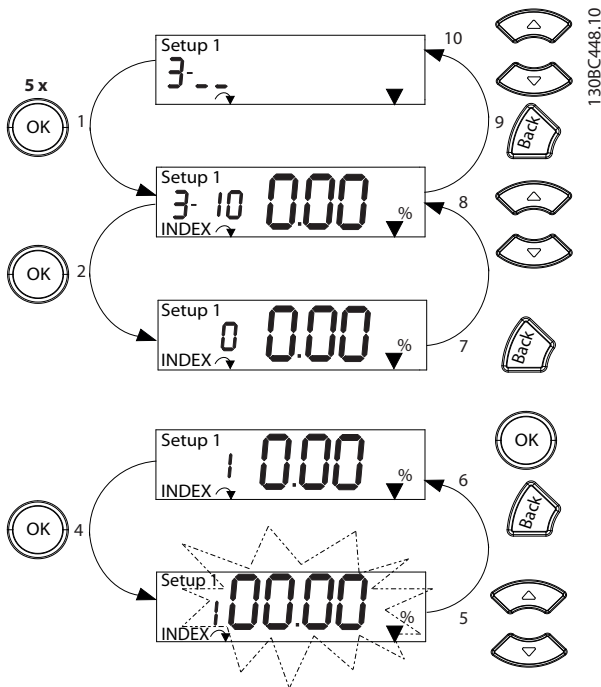

Illustration 5.9 Main Menu Interactions - Array Parameters

1	[OK]: Shows parameter numbers and the value in the first index.
2	[OK]: Index can be selected.
3	[▲][▼]: Select index.
4	[OK]: Value can be edited.
5	[▲][▼]: Change parameter value (flashing).
6	[Back]: Cancels changes. [OK]: Accepts changes.
7	[Back]: Cancels editing index, a new parameter can be selected.
8	[▲][▼]: Select parameter within the group.
9	[Back]: Removes parameter index value and shows the parameter group.
10	[▲][▼]: Select group.

Table 5.7 Changing Values in Array Parameters

5.4.6 Graphical Local Control Panel

The graphical local control panel LCP 102 has a larger display area, which shows more information than LCP 21. LCP 102 supports English, Chinese, and Portuguese displays.

The GLCP is divided into 4 functional groups (see *Illustration 5.10*).

- A. Display area.
- B. Display menu keys.

C. Navigation keys and indicator lights (LEDs).

D. Operation keys and reset.

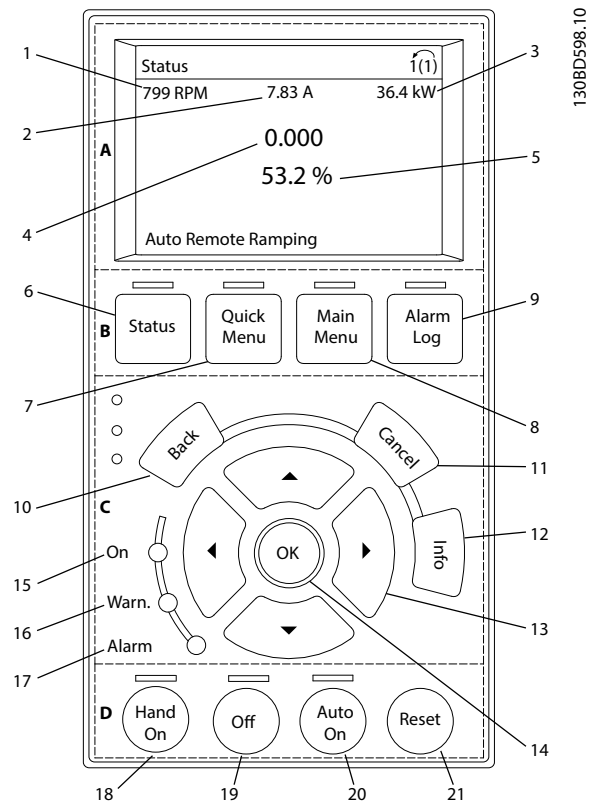

Illustration 5.10 Graphic Local Control Panel (GLCP)

A. Display area

The display area is activated when the frequency converter receives power from the mains voltage or a DC bus terminal.

The information shown on the LCP can be customized for user applications. Select options in the *Quick Menu Q3-13 Display Settings*.

Display	Parameter number	Default setting
1	0-20	[1602] Reference [%]
2	0-21	[1614] Motor Current
3	0-22	[1610] Power [kW]
4	0-23	[1613] Frequency
5	0-24	[1502] kWh Counter

Table 5.8 Legend to *Illustration 5.10*, Display Area

B. Display menu keys

Menu keys are used for menu access for parameter set-up, toggling through status display modes during normal operation, and viewing fault log data.

	Key	Function
6	Status	Shows operational information.

	Key	Function
7	Quick Menu	Allows access to programming parameters for initial set-up instructions and many detailed application instructions.
8	Main Menu	Allows access to all programming parameters.
9	Alarm Log	Shows a list of current warnings, the last 10 alarms, and the maintenance log.

Table 5.9 Legend to *Illustration 5.10, Display Menu Keys*

C. Navigation keys and indicator lights (LEDs)

Navigation keys are used for programming functions and moving the display cursor. The navigation keys also provide speed control in local operation. There are also 3 frequency converter status indicator lights in this area.

	Key	Function
10	Back	Reverts to the previous step or list in the menu structure.
11	Cancel	Cancels the last change or command as long as the display mode has not changed.
12	Info	Press for a definition of the function being shown.
13	Navigation keys	To move between items in the menu, use the 4 navigation keys.
14	OK	Press to access parameter groups or to enable a selection.

Table 5.10 Legend to *Illustration 5.10, Navigation Keys*

	Indicator	Light	Function
15	On	Green	ON turns on when the frequency converter receives power from the mains voltage or a DC bus terminal.
16	Warn	Yellow	When warning conditions are met, the yellow WARN LED turns on, and text appears in the display area identifying the problem.
17	Alarm	Red	A fault condition causes the red alarm LED to flash, and an alarm text is shown.

Table 5.11 Legend to *Illustration 5.10, Indicator Lights (LEDs)*

D. Operation keys and reset

Operation keys are at the bottom of the LCP.

	Key	Function
18	Hand On	Starts the frequency converter in hand-on mode. <ul style="list-style-type: none"> An external stop signal by control input or serial communication overrides the local hand on.
19	Off	Stops the motor but does not remove power to the frequency converter.
20	Auto On	Puts the system in remote operational mode. <ul style="list-style-type: none"> Responds to an external start command by control terminals or serial communication.
21	Reset	Resets the frequency converter manually after a fault has been cleared.

Table 5.12 Legend to *Illustration 5.10, Operation Keys and Reset*

NOTICE

To adjust the display contrast, press [Status] and the [▲]/[▼] keys.

5.4.7 Changing Parameter Settings with GLCP

Access and change parameter settings from the *Quick Menu* or from the *Main Menu*. The *Quick Menu* only gives access to a limited number of parameters.

1. Press [Quick Menu] or [Main Menu] on the LCP.
2. Press [▲] [▼] to browse through the parameter groups, press [OK] to select a parameter group.
3. Press [▲] [▼] to browse through the parameters, press [OK] to select a parameter.
4. Press [▲] [▼] to change the value of a parameter setting.
5. Press [◀] [▶] to shift digit when a decimal parameter is in the editing state.
6. Press [OK] to accept the change.
7. Press either [Back] twice to enter Status, or press [Main Menu] once to enter the Main Menu.

View changes

Quick Menu Q5 - Changes Made lists all parameters changed from default settings.

- The list only shows parameters, which have been changed in the current edit set-up.
- Parameters which have been reset to default values are not listed.
- The message *Empty* indicates that no parameters have been changed.

5.4.8 Mounting the GLCP

Use the GLCP adapter (ordering number: 132B0281) and a cable to connect the LCP 102 to frequency converter, as shown in *Illustration 5.11*.

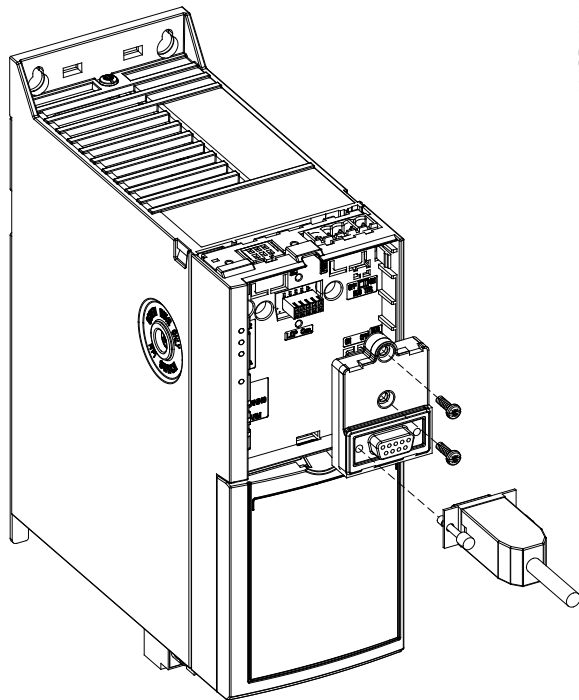

Illustration 5.11 GLCP Adapter and Connecting Cable

5.4.9 Backing Up/Downloading Parameters with LCP

Establishing the correct programming for applications often requires setting functions in several related parameters. Parameter details are provided in *chapter 9.2 Parameter Menu Structure*.

Programming data is stored internally in the frequency converter.

- For back-up, upload data into the LCP memory.
- To download data to another frequency converter, connect the LCP to that unit and download the stored settings.
- Restoring factory default settings does not change data stored in the LCP memory.

Back-up/download process

1. Press [Off] on GLCP or [Off Reset] on NLCP to stop the motor before uploading or downloading data.
2. Press [Main Menu] *parameter 0-50 LCP Copy* and press [OK].
3. Select [1] *All to LCP* to upload data to the LCP, or select [2] *All from LCP* to download data from the LCP, or select [3] *Size indep. from LCP* to download motor size independent parameters from LCP.
4. Press [OK]. A progress bar shows the uploading or downloading progress.
5. Press [Hand On] or [Auto On] to return to normal operation.

5.4.10 Restoring Default Settings with LCP

NOTICE

Risk of losing programming, motor data, localization, and monitoring records by restoration of default settings. To provide a back-up, upload data to the LCP before initialization.

Restoring the default parameter settings is done by initialization of the frequency converter. Initialization is carried out through *parameter 14-22 Operation Mode* (recommended) or manually. Initialization does not reset the settings for *parameter 1-06 Clockwise Direction* and *parameter 0-03 Regional Settings*.

- Initialization using *parameter 14-22 Operation Mode* does not reset frequency converter settings, such as operating hours, serial communication selections, fault log, alarm log, and other monitoring functions.
- Manual initialization erases all motor, programming, localization, and monitoring data, and restores factory default settings.

Recommended initialization procedure, via *parameter 14-22 Operation Mode*

1. Select *parameter 14-22 Operation Mode* and press [OK].
2. Select [2] *Initialisation* and press [OK].
3. Remove power to the unit and wait until the display turns off.
4. Apply power to the unit.

Default parameter settings are restored during start-up. This may take slightly longer than normal.

5. *Alarm 80, Drive initialised to default value* is shown.
6. Press [Reset] to return to operating mode.

Manual initialization procedure

1. Remove power to the unit and wait until the display turns off.
2. Press and hold [Status], [Main Menu], and [OK] at the same time on the GLCP, or press [Menu] and [OK] at the same time on the NLCP while applying power to the unit (approximately 5 s or until a click is heard and the fan starts).

Factory default parameter settings are restored during start-up. This may take slightly longer than normal.

Manual initialization does not reset the following frequency converter information:

- *Parameter 0-03 Regional Settings*
- *Parameter 1-06 Clockwise Direction*
- *Parameter 15-00 Operating hours*
- *Parameter 15-03 Power Up's*
- *Parameter 15-04 Over Temp's*
- *Parameter 15-05 Over Volt's*
- *Parameter 15-30 Alarm Log: Error Code*

5.5 Basic Programming**5.5.1 Asynchronous Motor Set-up**

Enter the following motor data in the listed order. Find the information on the motor nameplate.

1. *Parameter 1-20 Motor Power.*
2. *Parameter 1-22 Motor Voltage.*
3. *Parameter 1-23 Motor Frequency.*
4. *Parameter 1-24 Motor Current.*
5. *Parameter 1-25 Motor Nominal Speed.*

For optimum performance in VVC⁺ mode, extra motor data is required to set up the following parameters.

6. *Parameter 1-30 Stator Resistance (Rs).*
7. *Parameter 1-31 Rotor Resistance (Rr).*
8. *Parameter 1-33 Stator Leakage Reactance (X1).*
9. *Parameter 1-35 Main Reactance (Xh).*

The data is found in the motor datasheet (this data is typically not available on the motor nameplate). Run a complete AMA using *parameter 1-29 Automatic Motor Adaption (AMA) [1] Enable Complete AMA* or enter the parameters manually.

Application-specific adjustment when running VVC⁺

VVC⁺ is the most robust control mode. In most situations, it provides optimum performance without further adjustments. Run a complete AMA for best performance.

5.5.2 PM Motor Set-up in VVC⁺**Initial programming steps**

1. Set *parameter 1-10 Motor Construction* to the following options to activate PM motor operation:
 - 1a *[1] PM, non salient SPM*
 - 1b *[3] PM, salient IPM*
2. Select *[0] Open Loop* in *parameter 1-00 Configuration Mode*.

NOTICE

Encoder feedback is not supported for PM motors.

Programming motor data

When the initial programming steps are completed, the PM motor-related parameters in parameter groups *1-2* Motor Data*, *1-3* Adv. Motor Data*, and *1-4* Adv. Motor Data II* are active.

The information is on the motor nameplate and in the motor datasheet.

Program the following parameters in the listed order:

1. *Parameter 1-24 Motor Current.*
2. *Parameter 1-26 Motor Cont. Rated Torque.*
3. *Parameter 1-25 Motor Nominal Speed.*
4. *Parameter 1-39 Motor Poles.*
5. *Parameter 1-40 Back EMF at 1000 RPM.*
6. *Parameter 1-42 Motor Cable Length.*

Run a complete AMA using *parameter 1-29 Automatic Motor Adaption (AMA)* and select *[1] Enable Complete AMA*. If a complete AMA is not performed successfully, configure the following parameters manually.

1. *Parameter 1-30 Stator Resistance (Rs).*
Enter phase common stator winding resistance (Rs). If only phase-to-phase data is available, divide the phase-to-phase value by 2 to achieve the phase value.
It is also possible to measure the value with an ohmmeter, which also takes the resistance of the cable into account. Divide the measured value by 2 and enter the result.
2. *Parameter 1-37 d-axis Inductance (Ld).*
Enter direct axis inductance of the PM motor. If only phase-to-phase data is available, divide the phase-to-phase value by 2 to achieve the phase value.
It is also possible to measure the value with an inductance meter, which also takes the inductance of the cable into account. Divide the measured value by 2 and enter the result.
3. *Parameter 1-38 q-axis Inductance (Lq).*

This parameter is active only when *parameter 1-10 Motor Construction* is set to [3] PM, salient IPM.

Enter the quadrature axis inductance of the PM motor. If only phase-to-phase data is available, divide the phase-to-phase value by 2 to achieve the phase value.

It is also possible to measure the value with an inductance meter, which also takes the inductance of the cable into account. Make 1 rotation of the motor's rotor and find the maximum phase-to-phase inductance value. Divide the value by 2 and enter the result.

4. *Parameter 1-44 d-axis Inductance Sat. (LdSat).*
This parameter is active only when *parameter 1-10 Motor Construction* is set to [3] PM, salient IPM.

This parameter corresponds to the saturation inductance of d-axis. The default value is the value set in *parameter 1-37 d-axis Inductance (Ld)*. Do not change the default value in most cases. If the motor supplier provides the saturation curve, enter the d-axis inductance value, which is 100% of the nominal current.

5. *Parameter 1-45 q-axis Inductance Sat. (LqSat).*
This parameter is active only when *parameter 1-10 Motor Construction* is set to [3] PM, salient IPM.

This parameter corresponds to the saturation inductance of q-axis. The default value is the value set in *parameter 1-38 q-axis Inductance (Lq)*. In most cases, do not change the default. If the motor supplier provides the saturation curve, enter the q-axis inductance value, which is 100% of the nominal current.

Test motor operation

1. Start the motor at low speed (100–200 RPM). If the motor does not run, check installation, general programming, and motor data.
2. Check if the start function in *parameter 1-70 Start Mode* fits the application requirements.

Rotor detection

This function is the recommended selection for applications where the motor starts from standstill, for example pumps or conveyors. For some motors, a sound is heard when the frequency converter performs the rotor detection. This sound does not harm the motor. Adjust the value in *parameter 1-46 Position Detection Gain* for different motors. If the frequency converter fails to start, or an overcurrent alarm occurs when the frequency converter starts, check if the rotor is blocked or not. If the rotor is not blocked, set *parameter 1-70 Start Mode* to [1] Parking and try again.

Parking

This function is the recommended option for applications where the motor is rotating at low speed, for example windmilling in fan applications. *Parameter 2-06 Parking Current* and *parameter 2-07 Parking Time* are adjustable. Increase the factory setting of these parameters for applications with high inertia.

Start the motor at nominal speed. If the application does not run well, check the VVC+ PM settings. *Table 5.13* shows recommendations in different applications.

Application	Settings
Low inertia applications $I_{Load}^1/I_{Motor}^2 < 5$	<ul style="list-style-type: none"> • Increase the value for <i>parameter 1-17 Voltage filter time const.</i> by factor 5 to 10. • Reduce the value for <i>parameter 1-14 Damping Gain</i>. • Reduce the value (<100%) for <i>parameter 1-66 Min. Current at Low Speed</i>.
Medium inertia applications $50 > I_{Load}/I_{Motor} > 5$	Keep calculated values.
High inertia applications $I_{Load}/I_{Motor} > 50$	Increase the values for <i>parameter 1-14 Damping Gain</i> , <i>parameter 1-15 Low Speed Filter Time Const.</i> , and <i>parameter 1-16 High Speed Filter Time Const.</i>
High load at low speed <30% (rated speed)	Decrease <i>parameter 1-17 Voltage filter time const.</i> Decrease <i>parameter 1-66 Min. Current at Low Speed</i> (>100% for longer time can overheat the motor).

Table 5.13 Recommendations in Different Applications

- 1) I_{Load} = The inertia of load.
- 2) I_{Motor} = The inertia of motor.

If the motor starts oscillating at a certain speed, increase *parameter 1-14 Damping Gain*. Increase the value in small steps.

Adjust the starting torque in *parameter 1-66 Min. Current at Low Speed*. 100% provides nominal torque as starting torque.

5.5.3 Automatic Motor Adaptation (AMA)

Automatic motor adaptation (AMA)

It is highly recommended to run AMA because it measures the electrical characteristics of the motor to optimize compatibility between the frequency converter and the motor under VVC+ mode.

- The frequency converter builds a mathematical model of the motor for regulating output motor current, thus enhancing motor performance.
- Some motors are unable to run the complete version of the test. In that case, select *Enable reduced AMA*.
- If warnings or alarms occur, see *chapter 7.3 Warning and Alarm Code List*.
- Run this procedure on a cold motor for best results.

To run AMA using the numeric LCP

1. By default parameter setting, connect terminals 12 and 27 before running AMA.
2. Enter the *Main Menu*.
3. Go to parameter group *1-** Load and Motor*.
4. Press [OK].
5. Set motor parameters using nameplate data for parameter group *1-2* Motor Data*.
6. Set *parameter 1-39 Motor Poles* for IM and PM.
7. Set *parameter 1-40 Back EMF at 1000 RPM* for PM.
8. Set motor cable length in *parameter 1-42 Motor Cable Length*.
9. Go to *parameter 1-29 Automatic Motor Adaptation (AMA)*.
10. Press [OK].
11. Select *[1] Enable complete AMA*.
12. Press [OK].
13. Press [Hand On] to activate AMA.
14. The test runs automatically and indicates when it is complete.

Depending on the power size, the AMA takes 3–10 minutes to complete.

NOTICE

The AMA function does not cause the motor to run, and it does not harm the motor.

5.6 Checking Motor Rotation

Before running the frequency converter, check the motor rotation.

1. Press [Hand On].
2. Press [▲] for positive speed reference.
3. Check that the speed shown is positive.
4. Verify that the wiring between the frequency converter and the motor is correct.

5. Verify that the motor running direction matches the setting in *parameter 1-06 Clockwise Direction*.
 - 5a When *parameter 1-06 Clockwise Direction* is set to *[0] Normal* (default clockwise):
 - a. Verify that the motor turns clockwise.
 - b. Verify that the LCP direction arrow is clockwise.
 - 5b When *parameter 1-06 Clockwise Direction* is set to *[1] Inverse* (counterclockwise):
 - a. Verify that the motor turns counterclockwise.
 - b. Verify that the LCP direction arrow is counterclockwise.

5.7 Checking Encoder Rotation

Only check encoder rotation if encoder feedback is used.

1. Select *[0] Open Loop* in *parameter 1-00 Configuration Mode*.
2. Select *[1] 24 V encoder* in *parameter 7-00 Speed PID Feedback Source*.
3. Press [Hand On].
4. Press [▲] for positive speed reference (*parameter 1-06 Clockwise Direction* at *[0] Normal*).
5. Check in *parameter 16-57 Feedback [RPM]* that the feedback is positive.

NOTICE

NEGATIVE FEEDBACK

If the feedback is negative, the encoder connection is wrong. Use *parameter 5-71 Term 32/33 Encoder Direction* to inverse the direction, or reverse the encoder cables.

5.8 Local-control Test

1. Press [Hand On] to provide a local start command to the frequency converter.
2. Accelerate the frequency converter by pressing [▲] to full speed. Moving the cursor left of the decimal point provides quicker input changes.
3. Note any acceleration problems.
4. Press [Off]. Note any deceleration problems.

If acceleration or deceleration problems occur, see *chapter 7.5 Troubleshooting*. See *chapter 7.1 Warning and Alarm Types* for resetting the frequency converter after a trip.

5.9 System Start-up

The procedure in this section requires user-wiring and application programming to be completed. The following procedure is recommended after application set-up is completed.

1. Press [Auto On].
2. Apply an external run command.
3. Adjust the speed reference throughout the speed range.
4. Remove the external run command.
5. Check the sound and vibration levels of the motor to ensure that the system is working as intended.

If warnings or alarms occur, see *chapter 7.1 Warning and Alarm Types* for resetting the frequency converter after a trip.

5.10 PROFIBUS

VLT® AutomationDrive FC 360 frequency converters support PROFIBUS. If PROFIBUS is needed,

- Order a new frequency converter on which the control cassette with PROFIBUS is pre-installed;
- Order a control cassette with PROFIBUS to replace the standard control cassette on an existing frequency converter. In this case, upgrade the firmware with MCT-10 Set-up Software.

In both cases, ensure that *parameter 15-43 Software Version* is higher than 1.20.

Illustration 5.12 shows the front panel of a control cassette with PROFIBUS.

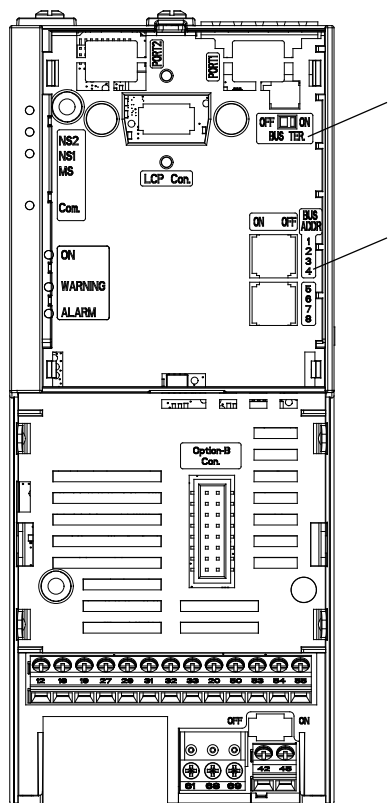

1	Termination resistor switch
2	PROFIBUS address selector

Illustration 5.12 Front Panel of a Control Cassette with PROFIBUS

The functions of the LEDs and switches on the front panel are introduced in *Table 5.14*.

LED/Switch	Description
NS2	Not used for PROFIBUS.
NS1	Indicates the network status when communicating with the PROFIBUS master. When this indicator light shows constant green, data exchange between the master and the frequency converter is active.
MS	Indicates the module status, which is acyclic DP V1 communication from either a PROFIBUS master class 1 (PLC) or a master class 2 (MCT-10 Set-up Software, FDT tool). When this indicator light shows constant green, DP V1 communication from master classes 1 and 2 is active.
COM	Communication status for RS485. Not used for PROFIBUS.
Termination resistor switch	When the switch is turned on, the termination resistor is in effect.
PROFIBUS address selector	Use the switches in the selector to set the PROFIBUS address. The address change comes into effect at the next power-up. NOTICE Switch off the power supply before changing the switches.

Table 5.14 Functions of LEDs and Switches

The PROFIBUS decoupling kit contains parts that are required for PROFIBUS to work. Install the kit after the control cassette with PROFIBUS is installed. *Illustration 5.13* and *Illustration 5.14* show how to install the decoupling kit on a frequency converter.

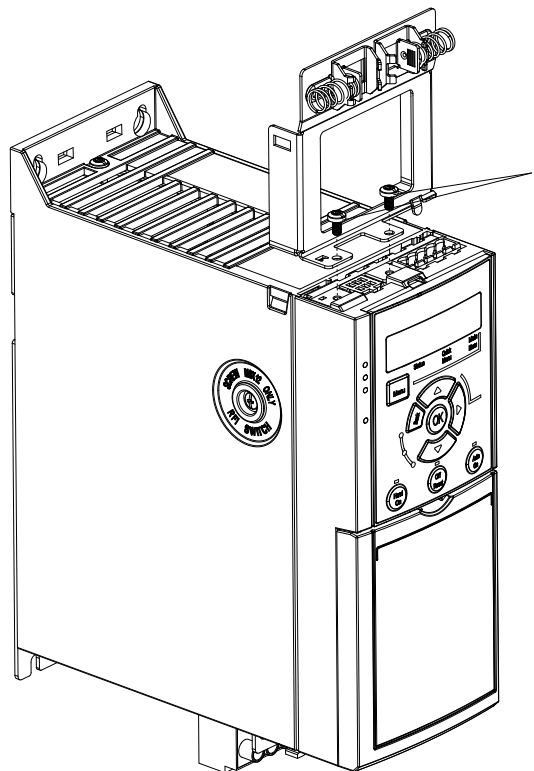

130BD616.10

1	Screws
---	--------

Illustration 5.13 Fasten the Plate with Screws

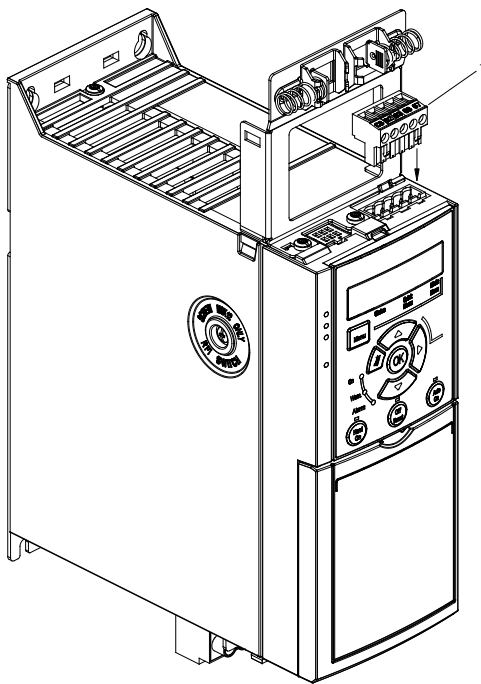

1	5-pin Connector
---	-----------------

Illustration 5.14 Push the 5-pin Connector into Place

5.11 PROFINET

VLT® AutomationDrive FC 360 frequency converters support PROFINET. If PROFINET is needed,

- Order a new frequency converter on which the control cassette with PROFINET is pre-installed;
- Order a control cassette with PROFINET (ordering number: 132B0257) to replace the standard control cassette on an existing frequency converter. In this case, upgrade the software with MCT-10 Set-up Software. See the *service manual* for the instructions to upgrade the software.

In both cases, ensure that *parameter 15-43 Software Version* is higher than 1.40.

In the package of each control cassette with PROFINET, a decoupling kit is provided for better mechanical fixation. Install the decoupling kit after the control cassette is installed.

To install the decoupling kit:

1. Place the decoupling plate on the control cassette that is mounted on the frequency converter, and fasten the plate using 2 screws (supplied), as shown in *Illustration 5.15*. Tightening torque 0.7–1.0 Nm (6.2–8.9 in-lb).

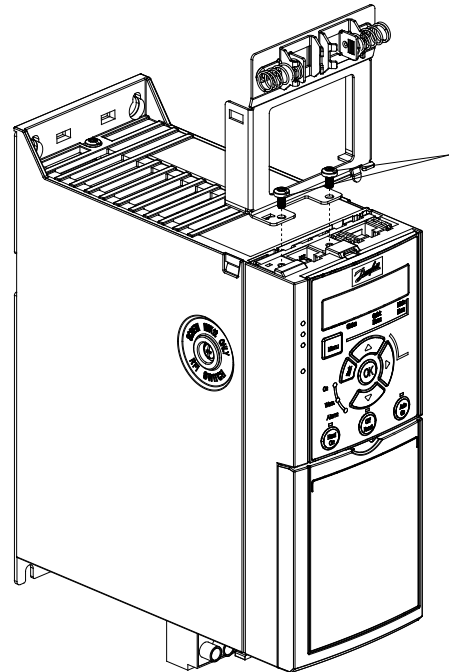

1	Screws
---	--------

Illustration 5.15 Fasten the Plate with Screws

2. Push the Ethernet cable connectors into the slots on the control cassette. Place Ethernet cables between the spring loaded metal clamps, as shown in *Illustration 5.16*, to establish mechanical fixation and electrical contact between the cable and ground.

5

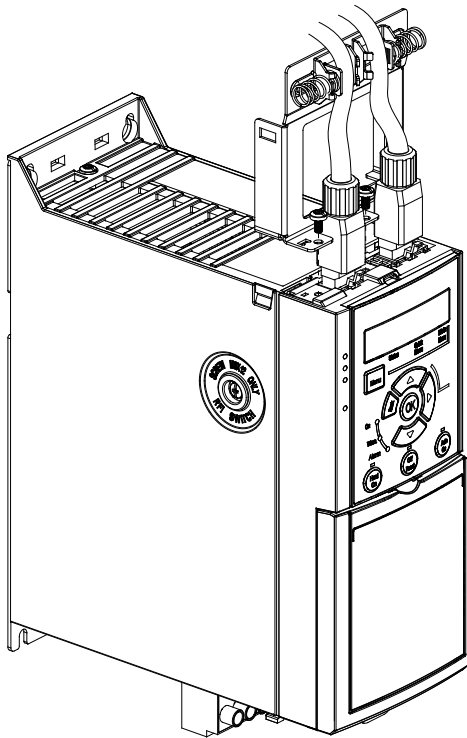

130BE308.10

Illustration 5.16 Place Ethernet Cables between Clamps

6 Applications

6.1 Application Selections

Use the selections for quick application set-up of the most common applications by setting *parameter 0-16 Application Selection*. When necessary, the selections can be modified for individual needs. All selections are for auto-on mode.

NOTICE

When an application is selected, relevant parameters are automatically set. Customer-specific configuration of all parameters based on specific requirements is still possible.

NOTICE

It is recommended to initialize the frequency converter via *parameter 14-22 Operation Mode* or 2 finger reset before setting *parameter 0-16 Application Selection*.

NOTICE

If any of the applications are selected, relay 1 is set to [Running] and relay 2 is set to [Alarm] automatically.

Application	
Pumps, fans, compressors. <i>Parameter 0-16 Application Selection</i> is set to [1] Simple Process Close Loop.	
Description	
For applications where a value (for example, pressure, temperature) must be kept at a desired level by sensor feedback.	
Parameter settings	
Parameter	Option/value
<i>Parameter 1-00 Configuration Mode</i>	[3] Process Closed Loop
<i>Parameter 1-03 Torque Characteristics</i>	[1] Variable Torque
<i>Parameter 3-00 Reference Range</i>	[0] Min- Max
<i>Parameter 3-15 Reference 1 Source</i>	[0] No Function
<i>Parameter 4-12 Motor Speed Low Limit [Hz]</i>	30.0 Hz
<i>Parameter 4-14 Motor Speed High Limit [Hz]</i>	50.0 Hz
<i>Parameter 5-10 Terminal 18 Digital Input</i>	[8] Start
<i>Parameter 5-12 Terminal 27 Digital Input</i>	[2] Coast Inverse
<i>Parameter 5-14 Terminal 32 Digital Input</i>	[14] Jog
<i>Parameter 5-40 Function Relay (Relay 1 Selection)</i>	[5] Running
<i>Parameter 5-40 Function Relay (Relay 2 Selection)</i>	[9] Alarm
<i>Parameter 6-22 Terminal 54 Low Current</i>	4.0 mA
<i>Parameter 6-23 Terminal 54 High Current</i>	20.0 mA
<i>Parameter 6-29 Terminal 54 mode</i>	[0] Current Mode
<i>Parameter 6-70 Terminal 45 Mode</i>	[0] 0-20 mA

Parameter 6-71 Terminal 45 Analog Output	[100] Output frequency
Parameter 6-90 Terminal 42 Mode	[0] 0–20 mA
Parameter 6-91 Terminal 42 Analog Output	[103] Motor Current
Parameter 7-20 Process CL Feedback 1 Resource	[2] Analog input 54

Table 6.1 Process Closed Loop

Application		
Local/remote. Parameter 0-16 Application Selection is set to [2] Local/Remote.		
Description		
For applications where the speed reference can be switched between local potentiometer and remote current signal.		
Parameter settings	Set-up 1	Set-up 2
Parameter 0-10 Active Set-up	[9] Multi Set-up	[9] Multi Set-up
Parameter 0-12 Link Setups	[20] Linked	[20] Linked
Parameter 1-00 Configuration Mode	[0] Speed Open Loop	[0] Speed Open Loop
Parameter 3-00 Reference Range	[0] Min–Max	[0] Min–Max
Parameter 3-15 Reference 1 Source	[1] AI 53	[2] AI 54
Parameter 3-16 Reference 2 Source	[0] No function	[0] No function
Parameter 4-12 Motor Speed Low Limit [Hz]	25.0 Hz	25.0 Hz
Parameter 4-14 Motor Speed High Limit [Hz]	50.0 Hz	50.0 Hz

Parameter 5-10 Terminal 18 Digital Input	[8] Start	[8] Start
Parameter 5-12 Terminal 27 Digital Input	[2] Coast Inverse	[2] Coast Inverse
Parameter 5-14 Terminal 32 Digital Input	[23] Set-up select	[23] Set-up select
Parameter 5-40 Function Relay (Relay 1 Selection)	[5] Running	[5] Running
Parameter 5-40 Function Relay (Relay 2 Selection)	[9] Alarm	[9] Alarm
Parameter 6-10 Terminal 53 Low Voltage	0.07 V	
Parameter 6-11 Terminal 53 High Voltage	10 V	
Parameter 6-19 Terminal 53 mode	[1] Voltage Mode	
Parameter 6-22 Terminal 54 Low Current		4.0 mA
Parameter 6-23 Terminal 54 High Current		20.0 mA
Parameter 6-29 Terminal 54 mode		[0] Current Mode
Parameter 6-70 Terminal 45 Mode	[0] 0–20 mA	[0] 0–20 mA
Parameter 6-71 Terminal 45 Analog Output	[100] Output frequency	[100] Output frequency
Parameter 6-90 Terminal 42 Mode	[0] 0–20 mA	[0] 0–20 mA
Parameter 6-91 Terminal 42 Analog Output	[103] Motor Current	[103] Motor Current

Table 6.2 Local/Remote

Application	
Conveyors, extruders.	
Parameter 0-16 Application Selection is set to [3] Speed Open Loop.	
Description	
For running at a stable speed by a voltage reference signal.	
Parameter settings	
Parameter	Option/value
Parameter 1-00 Configuration Mode	[0] Speed Open Loop
Parameter 3-00 Reference Range	[0] Min-Max
Parameter 3-15 Reference 1 Source	[1] AI 53
Parameter 4-12 Motor Speed Low Limit [Hz]	25.0 Hz
Parameter 4-14 Motor Speed High Limit [Hz]	50.0 Hz
Parameter 5-10 Terminal 18 Digital Input	[8] Start
Parameter 5-12 Terminal 27 Digital Input	[2] Coast Inverse
Parameter 5-40 Function Relay (Relay 1 Selection)	[5] Running
Parameter 5-40 Function Relay (Relay 2 Selection)	[9] Alarm
Parameter 6-10 Terminal 53 Low Voltage	0.07 V
Parameter 6-11 Terminal 53 High Voltage	10 V
Parameter 6-19 Terminal 53 mode	[1] Voltage Mode
Parameter 6-70 Terminal 45 Mode	[0] 0–20 mA
Parameter 6-71 Terminal 45 Analog Output	[100] Output frequency
Parameter 6-90 Terminal 42 Mode	[0] 0–20 mA
Parameter 6-91 Terminal 42 Analog Output	[103] Motor Current

Table 6.3 Speed Open Loop

Application	
Machine tools, texturizers.	
Parameter 0-16 Application Selection is set to [4] Simple Speed Closed Loop.	
Description	
For precise speed applications with 24 V encoder feedback.	
Parameter settings	
Parameter	Option/value
Parameter 1-00 Configuration Mode	[1] Speed Close Loop
Parameter 3-00 Reference Range	[0] Min-Max
Parameter 3-15 Reference 1 Source	[1] AI 53
Parameter 3-16 Reference 2 Source	[11] Local Bus Ref
Parameter 4-12 Motor Speed Low Limit [Hz]	20.0 Hz
Parameter 4-14 Motor Speed High Limit [Hz]	50.0 Hz
Parameter 5-10 Terminal 18 Digital Input	[8] Start
Parameter 5-12 Terminal 27 Digital Input	[2] Coast Inverse
Parameter 5-14 Terminal 32 Digital Input	[82] Encoder input B
Parameter 5-15 Terminal 33 Digital Input	[81] Encoder input A
Parameter 5-40 Function Relay (Relay 1 Selection)	[5] Running
Parameter 5-40 Function Relay (Relay 2 Selection)	[9] Alarm
Parameter 6-10 Terminal 53 Low Voltage	0.07 V
Parameter 6-11 Terminal 53 High Voltage	10 V
Parameter 6-19 Terminal 53 mode	[1] Voltage Mode
Parameter 6-70 Terminal 45 Mode	[0] 0–20 mA
Parameter 6-71 Terminal 45 Analog Output	[100] Output frequency
Parameter 6-90 Terminal 42 Mode	[0] 0–20 mA

Parameter 6-91 Terminal 42 Analog Output	[103] Motor Current
Parameter 7-00 Speed PID Feedback Source	[1] 24 V encoder

Table 6.4 Speed Close Loop

6

Application
 Industrial washing machines, conveyors.
 Parameter 0-16 Application Selection is set to [5] Multi Speed.

Description
 For applications with 8 different speeds by digital input. By using another digital input, 16 speeds are possible.

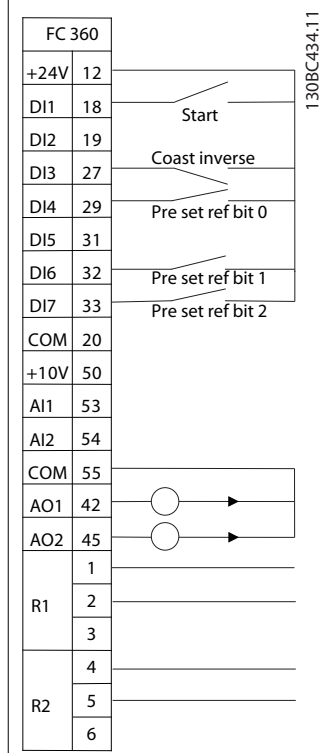

Parameter settings	
Parameter	Option/value
Parameter 1-00 Configuration Mode	[0] Speed Open Loop
Parameter 3-00 Reference Range	[0] Min-Max
Parameter 3-15 Reference 1 Source	[0] No Function
Parameter 4-14 Motor Speed High Limit [Hz]	50.0 Hz
Parameter 5-10 Terminal 18 Digital Input	[8] Start
Parameter 5-12 Terminal 27 Digital Input	[2] Coast Inverse
Parameter 5-13 Terminal 29 Digital Input	[16] Preset ref bit 0
Parameter 5-14 Terminal 32 Digital Input	[17] Preset ref bit 1
Parameter 5-15 Terminal 33 Digital Input	[18] Preset ref bit 2
Parameter 6-70 Terminal 45 Mode	[0] 0-20 mA
Parameter 6-71 Terminal 45 Analog Output	[100] Output frequency
Parameter 6-90 Terminal 42 Mode	[0] 0-20 mA
Parameter 6-91 Terminal 42 Analog Output	[103] Motor Current

Table 6.5 Multi-speed

Application	
One Gear Drive (OGD) LA10. Parameter 0-16 Application Selection is set to [6] OGD LA10.	
Description	
For applications that use OGD. For example, conveyors in food and beverage industries.	
Parameter settings	
Parameter	Option/value
Parameter 1-00 Configuration Mode	[0] Open Loop
Parameter 1-01 Motor Control Principle	[1] VVC+
Parameter 1-08 Motor Control Bandwidth	High
Parameter 1-10 Motor Construction	[1] PM, non-salient SPM
Parameter 1-14 Damping Gain	120
Parameter 1-15 Low Speed Filter Time Const.	0.175
Parameter 1-16 High Speed Filter Time Const.	0.175
Parameter 1-17 Voltage filter time const.	0.035
Parameter 1-24 Motor Current	7.2
Parameter 1-25 Motor Nominal Speed	3000
Parameter 1-26 Motor Cont. Rated Torque	12.6
Parameter 1-29 Automatic Motor Adaptation (AMA)	[0] Off
Parameter 1-30 Stator Resistance (Rs)	0.5
Parameter 1-37 d-axis Inductance (Ld)	5
Parameter 1-39 Motor Poles	10
Parameter 1-40 Back EMF at 1000 RPM	120
Parameter 1-42 Motor Cable Length	50 m
Parameter 1-66 Min. Current at Low Speed	50
Parameter 1-73 Flying Start	[2] Enable always
Parameter 2-06 Parking Current	80

Parameter 2-07 Parking Time	0.5
Parameter 2-10 Brake Function	[0] Off
Parameter 3-03 Maximum Reference	250 Hz
Parameter 4-14 Motor Speed High Limit [Hz]	250 Hz
Parameter 4-16 Torque Limit Motor Mode	160
Parameter 4-18 Current Limit	160
Parameter 5-10 Terminal 18 Digital Input	[8] Start
Parameter 5-11 Terminal 19 Digital Input	[0] No operation
Parameter 5-12 Terminal 27 Digital Input	[2] Coast inverse
Parameter 5-13 Terminal 29 Digital Input	[0] No operation
Parameter 5-14 Terminal 32 Digital Input	[0] No operation
Parameter 5-15 Terminal 33 Digital Input	[0] No operation
Parameter 5-16 Terminal 31 Digital Input	[0] No operation
Parameter 6-10 Terminal 53 Low Voltage	4.0 mA
Parameter 6-11 Terminal 53 High Voltage	20.0 mA
Parameter 6-14 Terminal 53 Low Ref./ Feedb. Value	0
Parameter 6-15 Terminal 53 High Ref./ Feedb. Value	250
Parameter 6-19 Terminal 53 mode	[0] Current Mode
Parameter 14-01 Switching Frequency	10.0 kHz
Parameter 14-07 Dead Time Compensation Level	65
Parameter 14-64 Dead Time Compensation Zero Current Level	[0] Disabled
Parameter 14-65 Speed Derate Dead Time Compensation	250
Parameter 14-51 DC-Link Voltage Compensation	[0] Off
Parameter 30-20 High Starting Torque Time [s]	0
Parameter 30-21 High Starting Torque Current [%]	100
Parameter 30-22 Locked Rotor Protection	[0] Off
Parameter 30-23 Locked Rotor Detection Time [s]	1

Table 6.6 One Gear Drive (OGD) LA10

Application	
One Gear Drive (OGD) V210. Parameter 0-16 Application Selection is set to [7] OGD V210.	
Description	
For applications that use OGD. For example, conveyors in food and beverage industries.	
Parameter settings	
Parameter	Option/value
Parameter 1-00 Configuration Mode	[0] Open Loop
Parameter 1-01 Motor Control Principle	[1] VVC+
Parameter 1-08 Motor Control Bandwidth	High
Parameter 1-10 Motor Construction	[1] PM, non-salient SPM
Parameter 1-14 Damping Gain	120
Parameter 1-15 Low Speed Filter Time Const.	0.175
Parameter 1-16 High Speed Filter Time Const.	0.175
Parameter 1-17 Voltage filter time const.	0.035
Parameter 1-24 Motor Current	5.50
Parameter 1-25 Motor Nominal Speed	3000
Parameter 1-26 Motor Cont. Rated Torque	13.0
Parameter 1-29 Automatic Motor Adaptation (AMA)	[0] Off
Parameter 1-30 Stator Resistance (Rs)	1.000
Parameter 1-37 d-axis Inductance (Ld)	13.800
Parameter 1-39 Motor Poles	10
Parameter 1-40 Back EMF at 1000 RPM	155
Parameter 1-42 Motor Cable Length	50 m
Parameter 1-66 Min. Current at Low Speed	50
Parameter 1-73 Flying Start	[2] Enable always
Parameter 2-06 Parking Current	10

Parameter 2-07 Parking Time	0.5
Parameter 2-10 Brake Function	[0] Off
Parameter 3-03 Maximum Reference	250 Hz
Parameter 4-14 Motor Speed High Limit [Hz]	250 Hz
Parameter 4-16 Torque Limit Motor Mode	160
Parameter 4-18 Current Limit	160
Parameter 5-10 Terminal 18 Digital Input	[8] Start
Parameter 5-11 Terminal 19 Digital Input	[0] No operation
Parameter 5-12 Terminal 27 Digital Input	[2] Coast inverse
Parameter 5-13 Terminal 29 Digital Input	[0] No operation
Parameter 5-14 Terminal 32 Digital Input	[0] No operation
Parameter 5-15 Terminal 33 Digital Input	[0] No operation
Parameter 5-16 Terminal 31 Digital Input	[0] No operation
Parameter 6-10 Terminal 53 Low Voltage	4.0 mA
Parameter 6-11 Terminal 53 High Voltage	20.0 mA
Parameter 6-14 Terminal 53 Low Ref./ Feedb. Value	0
Parameter 6-15 Terminal 53 High Ref./ Feedb. Value	250
Parameter 6-19 Terminal 53 mode	[0] Current Mode
Parameter 14-01 Switching Frequency	10.0 kHz
Parameter 14-07 Dead Time Compensation Level	65
Parameter 14-64 Dead Time Compensation Zero Current Level	[0] Disabled
Parameter 14-65 Speed Derate Dead Time Compensation	250
Parameter 14-51 DC-Link Voltage Compensation	[0] Off
Parameter 30-20 High Starting Torque Time [s]	0
Parameter 30-21 High Starting Torque Current [%]	100
Parameter 30-22 Locked Rotor Protection	[0] Off
Parameter 30-23 Locked Rotor Detection Time [s]	1

Table 6.7 One Gear Drive (OGD) V210

6.2 Application Examples

6.2.1 Introduction

The examples in this section are intended as a quick reference for common applications.

- Parameter settings are the regional default values unless otherwise indicated (selected in parameter 0-03 Regional Settings).
- Parameters associated with the terminals and their settings are shown next to the drawings.
- Required switch settings for analog terminals 53 or 54 are also shown.

6.2.2 AMA

		Parameters	
FC		Function	Setting
+24 V	12	Parameter 1-29 Automatic Motor Adaptation (AMA)	[1] Enable complete AMA
D IN	18		
D IN	19		
D IN	27		
D IN	29		
D IN	31		
D IN	32		
D IN	33		
+10 V	50	Parameter 5-12 Terminal 27 Digital Input	*[2] Coast inverse
A IN	53		
A IN	54		
COM	55		
A OUT	42		
		*=Default value	
Notes/comments: Set parameter group 1-2* Motor Data according to motor specifications.			
NOTICE			
If terminals 12 and 27 are not connected, set parameter 5-12 Terminal 27 Digital Input to [0] No operation.			

Table 6.8 AMA with T27 Connected

6.2.3 Speed

		Parameters	
FC		Function	Setting
+24 V	12	Parameter 6-10 Terminal 53 Low Voltage	*0.07 V
D IN	18		
D IN	19		
D IN	27		
D IN	29		
D IN	31		
D IN	32		
D IN	33		
+10 V	50	Parameter 6-11 Terminal 53 High Voltage	*10 V
A IN	53		
A IN	54		
COM	55		
A OUT	42		
		Parameter 6-14 Terminal 53 Low Ref./Feedb. Value	
		*0	
		Parameter 6-15 Terminal 53 High Ref./Feedb. Value	
		50 Hz	
		Parameter 6-19 Terminal 53 mode	
		*[1] Voltage	
		*=Default value	
Notes/comments:			

Table 6.9 Analog Speed Reference (Voltage)

		Parameters	
FC		Function	Setting
+24 V	12	Parameter 6-22 Terminal 54 Low Current	*4 mA
D IN	18		
D IN	19		
D IN	27		
D IN	29		
D IN	31		
D IN	32		
D IN	33		
+10 V	50	Parameter 6-23 Terminal 54 High Current	*20 mA
A IN	53		
A IN	54		
COM	55		
A OUT	42		
		Parameter 6-24 Terminal 54 Low Ref./Feedb. Value	
		*0	
		Parameter 6-25 Terminal 54 High Ref./Feedb. Value	
		50 Hz	
		Parameter 6-29 Terminal 54 mode	
		[0] current	
		*=Default value	
Notes/comments:			

Table 6.10 Analog Speed Reference (Current)

		Parameters	
FC		Function	Setting
+24 V	12	Parameter 6-10 Terminal 53 Low Voltage	*0.07 V
D IN	18		
D IN	19		
D IN	27		
D IN	29		
D IN	31		
D IN	32		
D IN	33		
+10 V	50	Parameter 6-11 Terminal 53 High Voltage	*10 V
A IN	53		
A IN	54		
COM	55		
A OUT	42		
		Parameter 6-14 Terminal 53 Low Ref./Feedb. Value	
		*0	
		Parameter 6-15 Terminal 53 High Ref./Feedb. Value	
		50 Hz	
		Parameter 6-19 Terminal 53 mode	
		*[1] voltage	
		*=Default value	
Notes/comments:			

Table 6.11 Speed Reference (Using a Manual Potentiometer)

		Parameters	
FC		Function	Setting
+24 V	12	Parameter 5-10 Terminal 18 Digital Input	*[8] Start
D IN	18		
D IN	19	Parameter 5-12 Terminal 27 Digital Input	[19] Freeze Reference
D IN	27		
D IN	29	Parameter 5-13 Terminal 29 Digital Input	[21] Speed Up
D IN	31		
D IN	32	Parameter 5-14 Terminal 32 Digital Input	[22] Speed Down
D IN	33		
+10 V	50	*=Default value	
A IN	53	Notes/comments:	
A IN	54		
COM	55		
A OUT	42		

Table 6.12 Speed Up/Speed Down

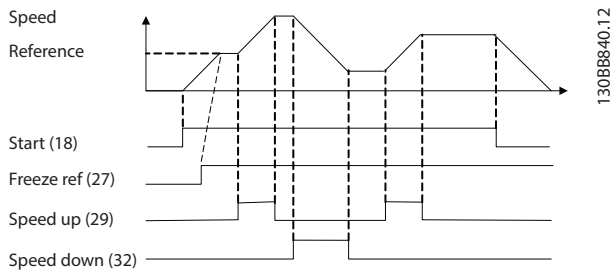

Illustration 6.1 Speed Up/Speed Down

6.2.4 Start/Stop

		Parameters	
FC		Function	Setting
+24 V	12	Parameter 5-10 Terminal 18 Digital Input	*[8] Start
D IN	18		
D IN	19	Parameter 5-11 Terminal 19 Digital Input	*[10] Reversing
D IN	27		
D IN	29	Parameter 5-12 Terminal 27 Digital Input	[0] No operation
D IN	31		
D IN	32	Parameter 5-14 Terminal 32 Digital Input	[16] Preset ref bit 0
D IN	33	Parameter 5-15 Terminal 33 Digital Input	[17] Preset ref bit 1
+10 V	50	Parameter 3-10 Preset Reference	
A IN	53	Preset ref. 0	25%
A IN	54	Preset ref. 1	50%
COM	55	Preset ref. 2	75%
A OUT	42	Preset ref. 3	100%
		*=Default value	
		Notes/comments:	

Table 6.13 Start/Stop with Reversing and 4 Preset Speeds

6.2.5 External Alarm Reset

		Parameters		
		Function	Setting	
	130BF823.10	Parameter 5-11 Terminal 19 Digital Input	[1] Reset	
		*=Default value		
		Notes/comments:		

Table 6.14 External Alarm Reset

6.2.6 Motor Thermistor

NOTICE

To meet PELV insulation requirements, use reinforced or double insulation on the thermistors.

		Parameters		
		Function	Setting	
	130BF824.10	Parameter 1-90 Motor Thermal Protection	[2] Thermistor trip	
		Parameter 1-93 Thermistor Source	[1] Analog input 53	
		Parameter 6-19 Terminal 53 mode	*[1] Voltage	
		* = Default value		
		Notes/comments:		
		If only a warning is needed, set parameter 1-90 Motor Thermal Protection to [1] Thermistor warning.		

Table 6.15 Motor Thermistor

7 Diagnostics and Troubleshooting

7.1 Warning and Alarm Types

Warning/ alarm type	Description
Warning	A warning indicates an abnormal operating condition that might lead to an alarm. A warning stops when the abnormal condition is removed.
Alarm	An alarm indicates a fault that requires immediate attention. The fault always triggers a trip or trip lock. Reset the frequency converter after an alarm. Reset the frequency converter in any of 4 ways: <ul style="list-style-type: none"> • Press [Reset]/[Off/Reset]. • Digital reset input command. • Bus communication reset input command. • Auto reset.

7

An alarm or trip lock alarm shows in the display along with the alarm number.

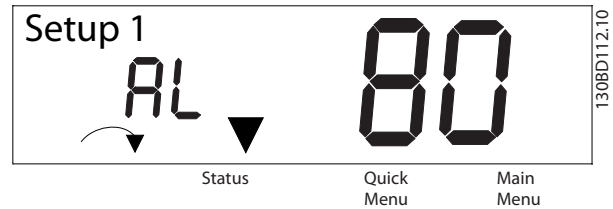

Illustration 7.2 Alarm/Trip Lock Alarm

In addition to the text and alarm code on the frequency converter display, there are 3 status indicator lights. The warning indicator light is yellow during a warning. The alarm indicator light is red and flashing during an alarm.

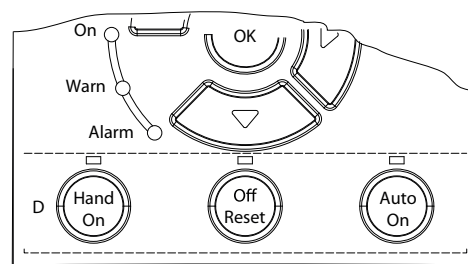

Illustration 7.3 Status Indicator Lights

Trip

When tripping, the frequency converter suspends operation to prevent damage to the frequency converter and other equipment. When a trip occurs, the motor coasts to a stop. The frequency converter logic continues to operate and monitor the frequency converter status. After the fault condition is remedied, the frequency converter is ready for a reset.

Trip lock

When trip locking, the frequency converter suspends operation to prevent damage to the frequency converter and other equipment. When a trip lock occurs, the motor coasts to a stop. The frequency converter logic continues to operate and monitor the frequency converter status. The frequency converter starts a trip lock only when serious faults occur that can damage the frequency converter or other equipment. After the faults are fixed, cycle the input power before resetting the frequency converter.

7.2 Warning and Alarm Displays

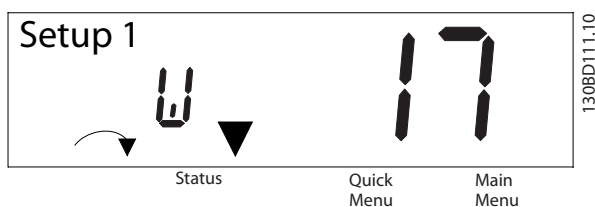

Illustration 7.1 Warning Display

7.3 Warning and Alarm Code List

An (X) marked in *Table 7.1* indicates that the warning or alarm has occurred. A warning precedes an alarm.

Number	Description	Warning	Alarm	Trip lock	Cause
2	Live zero error	X	X	-	Signal on terminal 53 or 54 is less than 50% of value set in <i>parameter 6-10 Terminal 53 Low Voltage</i> , <i>parameter 6-12 Terminal 53 Low Current</i> , <i>parameter 6-20 Terminal 54 Low Voltage</i> , and <i>parameter 6-22 Terminal 54 Low Current</i> .
3	No motor	X	-	-	No motor has been connected to the output of the frequency converter, or 1 motor phase is missing.
4	Mains phase loss ¹⁾	X	X	X	Missing phase on supply side, or the voltage imbalance is too high. Check the supply voltage.
7	DC overvoltage ¹⁾	X	X	-	Intermediate circuit voltage exceeds limit.
8	DC undervoltage ¹⁾	X	X	-	Intermediate circuit voltage drops below the voltage warning low limit.
9	Inverter overloaded	X	X	-	More than 100% load for too long.
10	Motor ETR overtemperature	X	X	-	Motor is too hot due to more than 100% load for too long.
11	Motor thermistor overtemperature	X	X	-	Thermistor or thermistor connection is disconnected.
12	Torque limit	X	X	-	Torque exceeds value set in either <i>parameter 4-16 Torque Limit Motor Mode</i> or <i>parameter 4-17 Torque Limit Generator Mode</i> .
13	Overcurrent	X	X	X	Inverter peak current limit is exceeded. For J1-J6 units, if this alarm occurs on power-up, check whether power cables are mistakenly connected to the motor terminals.
14	Earth fault	-	X	X	Discharge from output phases to ground.
16	Short circuit	-	X	X	Short circuit in motor or on motor terminals. For J7 units, if this alarm occurs on power-up, check whether power cables are mistakenly connected to the motor terminals.
17	Control word timeout	X	X	-	No communication to frequency converter.
18	Start failed	-	X	-	-
25	Brake resistor short-circuited	-	X	X	Brake resistor is short-circuited, thus the brake function is disconnected.
26	Brake overload	X	X	-	The power transmitted to the brake resistor over the last 120 s exceeds the limit. Possible corrections: Decrease brake energy via lower speed or longer ramp time.
27	Brake IGBT/Brake chopper short-circuited	-	X	X	Brake transistor is short-circuited, thus brake function is disconnected.
28	Brake check	-	X	-	Brake resistor is not connected/working.
30	U phase loss	-	X	X	Motor phase U is missing. Check the phase.
31	V phase loss	-	X	X	Motor phase V is missing. Check the phase.
32	W phase loss	-	X	X	Motor phase W is missing. Check the phase.
34	Fieldbus fault	X	X	-	PROFIBUS communication issues have occurred.
35	Option fault	-	X	-	Fieldbus or option B detects internal faults.
36	Mains failure	X	X	-	This warning/alarm is only active if the supply voltage to the frequency converter is lost and <i>parameter 14-10 Mains Failure</i> is NOT set to [0] No Function.
38	Internal fault	-	X	X	Contact the local Danfoss supplier.
40	Overload T27	X	-	-	Check the load connected to terminal 27 or remove short-circuit connection.

Number	Description	Warning	Alarm	Trip lock	Cause
41	Overload T29	X	-	-	Check the load connected to terminal 29 or remove short-circuit connection.
46	Gate drive voltage fault	-	X	X	-
47	24 V supply low	X	X	X	24 V DC may be overloaded.
50	AMA calibration	-	X	-	-
51	AMA check U _{nom} and I _{nom}	-	X	-	Wrong setting for motor voltage and/or motor current.
52	AMA low I _{nom}	-	X	-	Motor current is too low. Check the settings.
53	AMA big motor	-	X	-	The power size of the motor is too large for the AMA to operate.
54	AMA small motor	-	X	-	The power size of the motor is too small for the AMA to operate.
55	AMA parameter range	-	X	-	The parameter values of the motor are outside of the acceptable range. AMA does not run.
56	AMA interrupt	-	X	-	The AMA is interrupted.
57	AMA timeout	-	X	-	-
58	AMA internal	-	X	-	Contact Danfoss.
59	Current limit	X	X	-	Frequency converter overload.
60	External Interlock	-	X	-	-
61	Encoder loss	X	X	-	-
63	Mechanical brake low	-	X	-	Actual motor current has not exceeded release brake current within start delay time window.
65	Control card temp	X	X	X	The cutout temperature of the control card is 80 °C (176 °F).
69	Power card temp	X	X	X	-
70	Illegal FC config	-	X	X	-
80	Frequency converter initialized to default value	-	X	-	All parameter settings are initialized to default settings.
87	Auto DC brake	X	-	-	Occurs in IT mains when the frequency converter coasts and the DC voltage are higher than 830 V. Energy on DC-link is consumed by the motor. This function can be enabled/disabled in <i>parameter 0-07 Auto DC Braking</i> .
90	Feedback monitor	X	X	-	A feedback fault is detected by option B.
95	Broken belt	X	X	-	-
99	Locked rotor	-	X	-	-
101	Flow/pressure information missing	-	X	X	-
120	Position control fault	-	X	-	-
124	Tension limit	-	X	-	-
126	Motor rotating	-	X	-	-
127	Back EMF too high ²⁾	X	-	-	Try to start PM motor which is rotating in an abnormal high speed.
250	New spare part	-	X	X	-
251	New type code	-	X	X	-

Table 7.1 Warnings and Alarms Code List

1) These faults may be caused by mains distortions. Installing a Danfoss line filter may rectify this problem.

2) For enclosure size J7, the warning can also be caused by high UDC voltage.

For diagnosis, read out the alarm words, warning words, and extended status words.

Bit	Hex	Dec	Alarm word (parameter 1 6-90 Alarm Word)	Alarm word 2 (parameter 16-91 Alarm Word 2)	Alarm word 3 (parameter 1 6-97 Alarm Word 3)	Warning word (parameter 16- 92 Warning Word)	Warning word 2 (parameter 16 -93 Warning Word 2)	Extended status word (parameter 16- 94 Ext. Status Word)	Extended status word 2 (parameter 16-95 Ext . Status Word 2)
0	000000 01	1	Brake check	Reserved	Reserved	Reserved	Reserved	Ramping	Off
1	000000 02	2	Pwr. card temp	Gate drive voltage fault	Reserved	Pwr. card temp	Reserved	AMA tuning	Hand/Auto
2	000000 04	4	Earth fault	Reserved	Reserved	Reserved	Reserved	Start CW/CCW	PROFIBUS OFF1 active
3	000000 08	8	Ctrl. card temp	Reserved	Reserved	Ctrl. card temp	Reserved	Slowdown	PROFIBUS OFF2 active
4	000000 10	16	Ctrl. word TO	Illegal FC config	Reserved	Ctrl. word TO	Reserved	Catch up	PROFIBUS OFF3 active
5	000000 20	32	Overcurrent	Reserved	Reserved	Overcurrent	Reserved	Feedback high	Reserved
6	000000 40	64	Torque limit	Reserved	Reserved	Torque limit	Reserved	Feedback low	Reserved
7	000000 80	128	Motor Th. over	Reserved	Reserved	Motor Th. over	Reserved	Output current high	Control ready
8	000001 00	256	Motor ETR over	Broken belt	Reserved	Motor ETR over	Broken belt	Output current low	Frequency converter ready
9	000002 00	512	Inverter overld.	Reserved	Reserved	Inverter overld.	Reserved	Output freq. high	Quick stop
10	000004 00	1024	DC undervolt.	Start failed	Reserved	DC undervolt.	Reserved	Output freq. low	DC brake
11	000008 00	2048	DC overvolt.	Reserved	Reserved	DC overvolt.	Reserved	Brake check OK	Stop
12	000010 00	4096	Short circuit	External interlock	Reserved	Reserved	Reserved	Braking max	Latched
13	000020 00	8192	Reserved	Reserved	Reserved	Reserved	Reserved	Braking	Reserved
14	000040 00	16384	Mains ph. loss	Reserved	Reserved	Mains ph. loss	Reserved	Reserved	Freeze output
15	000080 00	32768	AMA not OK	Reserved	Reserved	No motor	Auto DC brake	OVC active	Reserved
16	000100 00	65536	Live zero error	Reserved	Reserved	Live zero error	Reserved	AC brake	Jog
17	000200 00	131072	Internal fault	Reserved	Reserved	Reserved	Reserved	Reserved	Reserved
18	000400 00	262144	Brake overload	Reserved	Reserved	Brake resistor power limit	Reserved	Reserved	Start
19	000800 00	524288	U phase loss	Reserved	Reserved	Reserved	Reserved	Reference high	Reserved
20	001000 00	1048576	V phase loss	Option detection	Reserved	Reserved	Overload T27	Reference low	Start delay
21	002000 00	2097152	W phase loss	Option fault	Reserved	Reserved	Reserved	Reserved	Sleep
22	004000 00	4194304	Fieldbus fault	Locked rotor	Reserved	Fieldbus fault	Reserved	Reserved	Sleep boost

Bit	Hex	Dec	Alarm word (parameter 1 6-90 Alarm Word)	Alarm word 2 (parameter 16-91 Alarm Word 2)	Alarm word 3 (parameter 1 6-97 Alarm Word 3)	Warning word (parameter 16- 92 Warning Word)	Warning word 2 (parameter 16 -93 Warning Word 2)	Extended status word (parameter 16- 94 Ext. Status Word)	Extended status word 2 (parameter 16-95 Ext . Status Word 2)
23	008000 00	8388608	24 V supply low	Position ctrl. fault	Reserved	24 V supply low	Reserved	Reserved	Running
24	010000 00	16777216	Mains failure	Tension Limit	Reserved	Mains failure	Reserved	Reserved	Bypass
25	020000 00	33554432	Reserved	Current limit	Reserved	Current limit	Reserved	Reserved	Reserved
26	040000 00	67108864	Brake resistor	Reserved	Reserved	Reserved	Reserved	Reserved	External interlock
27	080000 00	13421772 8	Brake IGBT	Reserved	Reserved	Reserved	Reserved	Reserved	Reserved
28	100000 00	26843545 6	Option change	Feedback fault	Reserved	Encoder loss	Reserved	Reserved	FlyStart active
29	200000 00	53687091 2	Frequency converter initialized	Encoder loss	Reserved	Reserved	Back EMF too high	Reserved	Heat sink clean warning
30	400000 00	10737418 24	Reserved	Reserved	Reserved	Reserved	Reserved	Reserved	Reserved
31	800000 00	21474836 48	Mech. brake low	Reserved	Reserved	Reserved	Reserved	Database busy	Reserved

Table 7.2 Description of Alarm Word, Warning Word, and Extended Status Word

7.4 Error Code List

LCP-related errors are shown in the format of **Err XX**, where XX indicates the error number. The LCP errors do not affect the operation of the frequency converter.

LCP error code	Description
Err 84	Communication between the LCP and the frequency converter is lost.
Err 85	The LCP key is disabled. One of the LCP keys is disabled in <i>parameter group 0-4* LCP Keypad</i> .
Err 86	Data copy failure: Occurs when data is copied from frequency converter to LCP, or from LCP to frequency converter (<i>parameter 0-50 LCP Copy</i>).
Err 87	Invalid LCP data: Occurs when data is being copied from LCP to frequency converter (<i>parameter 0-50 LCP Copy</i>).
Err 88	LCP data incompatible: Occurs when data is being copied from LCP to frequency converter (<i>parameter 0-50 LCP Copy</i>), typically because data is moved between frequency converters that have major software differences.
Err 89	An operation is issued via LCP to write a value to a parameter that is read-only.
Err 90	LCP, serial communication, or fieldbus communication attempts to update the same parameters at the same time.
Err 91	The parameter value that is input via the LCP is invalid.
Err 92	The parameter value that is input via the LCP exceeds limits.
Err 93	The LCP copy operation cannot be conducted when the frequency converter is running.
donE	A notification that the LCP Copy process is finished.
NWrun	The parameter cannot be changed while the frequency converter is running.
Err.	The password that is input via the LCP is incorrect.

Table 7.3 Error Code List

7.5 Troubleshooting

Symptom	Possible cause	Test	Solution
Motor not running	LCP stop	Check if [Off] has been pressed.	Press [Auto On] or [Hand On] (depending on operating mode) to run the motor.
	Missing start signal (standby)	Check <i>parameter 5-10 Terminal 18 Digital Input</i> of correct setting for terminal 18 (use default setting).	Apply a valid start signal to start the motor.
	Motor coast signal active (coasting)	Check <i>parameter 5-12 Terminal 27 Digital Input</i> for correct setting of terminal 27 (use default setting).	Apply 24 V on terminal 27 or program this terminal to [0] No operation.
	Wrong reference signal source	Check the following: <ul style="list-style-type: none"> The reference signal is local, remote, or bus reference? Preset reference is active? Terminal connection is correct? The scaling of terminals is correct? The reference signal is available? 	Program correct settings. Set preset reference active in <i>parameter group 3-1* References</i> . Check for correct wiring. Check scaling of terminals. Check reference signal.
Motor is running in the wrong direction	Motor rotation limit	Check that <i>parameter 4-10 Motor Speed Direction</i> is programmed correctly.	Program correct settings.
	Active reversing signal	Check if a reversing command is programmed for the terminal in <i>parameter group 5-1* Digital inputs</i> .	Deactivate reversing signal.
	Wrong motor phase connection	Change <i>parameter 1-06 Clockwise Direction</i> .	

Symptom	Possible cause	Test	Solution
Motor is not reaching maximum speed	Frequency limits are set incorrectly	Check output limits in <i>parameter 4-14 Motor Speed High Limit [Hz]</i> and <i>parameter 4-19 Max Output Frequency</i> .	Program correct limits.
	Reference input signal not scaled correctly	Check reference input signal scaling in <i>parameter group 6-** Analog I/O mode</i> and <i>parameter group 3-1* References</i> .	Program correct settings.
Motor speed is unstable	Possible incorrect parameter settings	Check the settings of all motor parameters, including all motor compensation settings. For closed-loop operation, check PID settings.	Check settings in <i>parameter group 6-** Analog I/O mode</i> .
Motor runs roughly	Possible overmagnetization	Check for incorrect motor settings in all motor parameters.	Check motor settings in <i>parameter groups 1-2* Motor data, 1-3* Adv motor data, and 1-5* Load indep. setting</i> .
Motor does not brake	Possible incorrect settings in the brake parameters. Possible too short ramp-down times.	Check brake parameters. Check ramp time settings.	Check <i>parameter groups 2-0* DC brake and 3-0* Reference limits</i> .
Open power fuses or circuit breaker trip	Phase-to-phase short	Motor or panel has a short phase-to-phase. Check motor and panel phase for shorts.	Eliminate any shorts detected.
	Motor overload	Motor is overloaded for the application.	Perform the start-up test and verify that motor current is within specifications. If motor current is exceeding nameplate full load current, the motor may run only with reduced load. Review the specifications for the application.
	Loose connections	Perform pre-start-up check for loose connections.	Tighten loose connections.
Mains current imbalance greater than 3%	Problem with mains power (see <i>alarm 4, Mains phase loss</i> description)	Rotate input power leads into the frequency converter 1 position: A to B, B to C, C to A.	If the imbalanced leg follows the wire, it is a power problem. Check mains supply.
	Problem with the frequency converter unit	Rotate input power leads into the frequency converter 1 position: A to B, B to C, C to A.	If the imbalanced leg stays on same input terminal, it is a problem with the unit. Contact the supplier.
Motor current imbalance greater than 3%	Problem with motor or motor wiring	Rotate output motor leads 1 position: U to V, V to W, W to U.	If the imbalanced leg follows the wire, the problem is in the motor or motor wiring. Check motor and motor wiring.
	Problem with the frequency converter unit	Rotate output motor leads 1 position: U to V, V to W, W to U.	If the imbalanced leg stays on same output terminal, it is a problem with the unit. Contact the supplier.
Acoustic noise or vibration (for example a fan blade is making noise or vibrations at certain frequencies)	Resonances, for example, in the motor/fan system	Bypass critical frequencies by using parameters in <i>parameter group 4-6* Speed Bypass</i> . Turn off overmodulation in <i>parameter 14-03 Overmodulation</i> . Increase resonance damping in <i>parameter 1-64 Resonance Dampening</i> .	Check if noise and/or vibration have been reduced to an acceptable limit.

Table 7.4 Troubleshooting

8 Specifications

8.1 Mains Supply 3x380–480 V AC

Frequency converter typical shaft output [kW (hp)]	HK37 0.37 (0.5)	HK55 0.55 (0.75)	HK75 0.75 (1)	H1K1 1.1 (1.5)	H1K5 1.5 (2)	H2K2 2.2 (3)	H3K0 3 (4)	H4K0 4 (5.5)	H5K5 5.5 (7.5)	H7K5 7.5 (10)
Enclosure protection rating IP20	J1	J1	J1	J1	J1	J1	J2	J2	J2	J3
Output current										
Shaft output [kW]	0.37	0.55	0.75	1.1	1.5	2.2	3	4	5.5	7.5
Continuous (3x380–440 V) [A]	1.2	1.7	2.2	3	3.7	5.3	7.2	9	12	15.5
Continuous (3x441–480 V) [A]	1.1	1.6	2.1	2.8	3.4	4.8	6.3	8.2	11	14
Intermittent (60 s overload) [A]	1.9	2.7	3.5	4.8	5.9	8.5	11.5	14.4	19.2	24.8
Continuous kVA (400 V AC) [kVA]	0.84	1.18	1.53	2.08	2.57	3.68	4.99	6.24	8.32	10.74
Continuous kVA (480 V AC) [kVA]	0.9	1.3	1.7	2.5	2.8	4.0	5.2	6.8	9.1	11.6
Maximum input current										
Continuous (3x380–440 V) [A]	1.2	1.6	2.1	2.6	3.5	4.7	6.3	8.3	11.2	15.1
Continuous (3x441–480 V) [A]	1.0	1.2	1.8	2.0	2.9	3.9	4.3	6.8	9.4	12.6
Intermittent (60 s overload) [A]	1.9	2.6	3.4	4.2	5.6	7.5	10.1	13.3	17.9	24.2
Additional specifications										
Maximum cable cross-section (mains, motor, brake, and load sharing) [mm ² (AWG)]	4 (12)									
Estimated power loss at rated maximum load [W] ²⁾	20.88	25.16	30.01	40.01	52.91	73.97	94.81	115.5	157.54	192.83
Weight [kg (lb)], enclosure protection rating IP20	2.3 (5.1)	2.3 (5.1)	2.3 (5.1)	2.3 (5.1)	2.3 (5.1)	2.5 (5.5)	3.6 (7.9)	3.6 (7.9)	3.6 (7.9)	4.1 (9.0)
Efficiency [%] ³⁾	96.2	97.0	97.2	97.4	97.4	97.6	97.5	97.6	97.7	98.0

Table 8.1 Mains Supply 3x380–480 V AC - Heavy Duty¹⁾

Frequency converter typical shaft output [kW (hp)]	H11K 11 (15)	H15K 15 (20)	H18K 18.5 (25)	H22K 22 (30)	H30K 30 (40)	H37K 37 (50)	H45K 45 (60)	H55K 55 (75)	H75K 75 (100)
Enclosure protection rating IP20	J4	J4	J5	J5	J6	J6	J6	J7	J7
Output current									
Continuous (3x380–440 V) [A]	23	31	37	42.5	61	73	90	106	147
Continuous (3x441–480 V) [A]	21	27	34	40	52	65	77	96	124
Intermittent (60 s overload) [A]	34.5	46.5	55.5	63.8	91.5	109.5	135	159	220.5
Continuous kVA (400 V AC) [kVA]	15.94	21.48	25.64	29.45	42.3	50.6	62.4	73.4	101.8
Continuous kVA (480 V AC) [kVA]	17.5	22.4	28.3	33.3	43.2	54.0	64.0	79.8	103.1
Maximum input current									
Continuous (3x380–440 V) [A]	22.1	29.9	35.2	41.5	57	70.3	84.2	102.9	140.3
Continuous (3x441–480 V) [A]	18.4	24.7	29.3	34.6	49.3	60.8	72.7	88.8	121.1
Intermittent (60 s overload) [A]	33.2	44.9	52.8	62.3	85.5	105.5	126.3	154.4	210.5
Additional specifications									
Maximum cable size (mains, motor, brake) [mm ² (AWG)]	16 (6)			50 (1/0)				85 (3/0)	
Estimated power loss at rated maximum load [W] ²⁾	289.53	393.36	402.83	467.52	630	848	1175	1250	1507
Weight [kg (lb)], enclosure protection rating IP20	9.4 (20.7)	9.5 (20.9)	12.3 (27.1)	12.5 (27.6)	22.4 (49.4)	22.5 (49.6)	22.6 (49.8)	37.3 (82.2)	38.7 (85.3)
Efficiency [%] ³⁾	97.8	97.8	98.1	97.9	98.1	98.0	97.7	98.0	98.2

Table 8.2 Mains Supply 3x380–480 V AC - Heavy Duty¹⁾

Frequency converter typical shaft output [kW (hp)]	Q11K 11 (15)	Q15K 15 (20)	Q18K 18.5 (25)	Q22K 22 (30)	Q30K 30 (40)	Q37K 37 (50)	Q45K 45 (60)	Q55K 55 (75)	Q75K 75 (100)
Enclosure protection rating IP20	J4	J4	J5	J5	J6	J6	J6	J7	J7
Output current									
Continuous (3x380–440 V) [A]	23	31	37	42.5	61	73	90	106	147
Continuous (3x441–480 V) [A]	21	27	34	40	52	65	77	96	124
Intermittent (60 s overload) [A]	25.3	34.1	40.7	46.8	67.1	80.3	99	116.6	161.7
Continuous kVA (400 V AC) [kVA]	15.94	21.48	25.64	29.45	42.3	50.6	62.4	73.4	101.8
Continuous kVA (480 V AC) [kVA]	17.5	22.4	28.3	33.3	43.2	54.0	64.0	79.8	103.1
Maximum input current									
Continuous (3x380–440 V) [A]	22.1	29.9	35.2	41.5	57	70.3	84.2	102.9	140.3
Continuous (3x441–480 V) [A]	18.4	24.7	29.3	34.6	49.3	60.8	72.7	88.8	121.1
Intermittent (60 s overload) [A]	24.3	32.9	38.7	45.7	62.7	77.3	92.6	113.2	154.3
Additional specifications									
Maximum cable size (mains, motor, brake) [mm ² (AWG)]	16 (6)				50 (1/0)				85 (3/0)
Estimated power loss at rated maximum load [W] ²	289.53	393.36	402.83	467.52	630	848	1175	1250	1507
Weight [kg (lb)], enclosure protection rating IP20	9.4 (20.7)	9.5 (20.9)	12.3 (27.1)	12.5 (27.6)	22.4 (49.4)	22.5 (49.6)	22.6 (49.8)	37.3 (82.2)	38.7 (85.3)
Efficiency [%] ³	97.8	97.8	98.1	97.9	98.1	98.0	97.7	98.0	98.2

Table 8.3 Mains Supply 3x380–480 V AC - Normal Duty¹⁾

1) Heavy duty=150–160% current during 60 s, Normal duty=110% current during 60 s.

2) The typical power loss is at nominal load conditions and expected to be within ±15% (tolerance relates to variety in voltage and cable conditions).

Values are based on a typical motor efficiency (IE2/IE3 border line). Motors with lower efficiency add to the power loss in the frequency converter and motors with high efficiency reduce power loss.

Applies for dimensioning of frequency converter cooling. If the switching frequency is higher than the default setting, the power losses may rise. LCP and typical control card power consumptions are included. Further options and customer load may add up to 30 W to the losses (though typical only 4 W extra for a fully loaded control card, fieldbus, or options for slot B).

For power loss data according to EN 50598-2, refer to www.danfoss.com/vlteneregyefficiency.

3) Measured using 5 m shielded motor cables at rated load and rated frequency for enclosure sizes J1–J5, and using 33 m shielded motor cables at rated load and rated frequency for enclosure sizes J6 and J7. For energy efficiency class, see the Ambient Conditions section in chapter 8 Specifications. For part load losses, see www.danfoss.com/vlteneregyefficiency.

8.2 General Technical Data

Mains supply (L1, L2, L3)

Supply terminals	L1, L2, L3
Supply voltage	380–480 V: -15% (-25%) ¹⁾ to +10%

1) The frequency converter can run at -25% input voltage with reduced performance. The maximum output power of the frequency converter is 75% if input voltage is -25%, and 85% if input voltage is -15%.

Full torque cannot be expected at mains voltage lower than 10% below the lowest rated supply voltage of the frequency converter.

Supply frequency	50/60 Hz ±5%
Maximum imbalance temporary between mains phases	3.0% of rated supply voltage
True power factor (λ)	≥0.9 nominal at rated load
Displacement power factor ($\cos \phi$)	Near unity (>0.98)
Switching on input supply L1, L2, L3 (power-ups) ≤7.5 kW	Maximum 2 times/minute
Switching on input supply L1, L2, L3 (power-ups) 11–75 kW	Maximum 1 time/minute

Motor output (U, V, W)

Output voltage	0–100% of supply voltage
Output frequency in U/f mode (for AM motor)	0–500 Hz
Output frequency in VVC ⁺ mode (for AM motor)	0–200 Hz
Output frequency in VVC ⁺ mode (for PM motor)	0–400 Hz
Switching on output	Unlimited
Ramp time	0.01–3600 s

Torque characteristics

Starting torque (high overload)	Maximum 160% for 60 s ¹⁾
Overload torque (high overload)	Maximum 160% for 60 s ¹⁾
Starting torque (normal overload)	Maximum 110% for 60 s ¹⁾
Overload torque (normal overload)	Maximum 110% for 60 s
Starting current	Maximum 200% for 1 s
Torque rise time in VVC ⁺ (independent of f_{sw})	Maximum 50 ms

1) Percentage relates to the nominal torque. It is 150% for 11–75 kW (15–100 hp) frequency converters.

Cable lengths and cross-sections¹⁾

Maximum motor cable length, shielded	50 m (164 ft)
Maximum motor cable length, unshielded	0.37–22 kW (0.5–30 hp): 75 m (246 ft), 30–75 kW (40–100 hp): 100 m (328 ft)
Maximum cross-section to control terminals, flexible/rigid wire	2.5 mm ² /14 AWG
Minimum cross-section to control terminals	0.55 mm ² /30 AWG

1) For power cables, see Table 8.1 to Table 8.3.

Digital inputs

Programmable digital inputs	7
Terminal number	18, 19, 27 ¹⁾ , 29 ¹⁾ , 32, 33, 31
Logic	PNP or NPN
Voltage level	0–24 V DC
Voltage level, logic 0 PNP	< 5 V DC
Voltage level, logic 1 PNP	> 10 V DC
Voltage level, logic 0 NPN	> 19 V DC
Voltage level, logic 1 NPN	< 14 V DC
Maximum voltage on input	28 V DC
Pulse frequency range	4 Hz–32 kHz
(Duty cycle) minimum pulse width	4.5 ms
Input resistance, R_i	approximately 4 kΩ

1) Terminals 27 and 29 can also be programmed as output.

Analog inputs

Number of analog inputs	2
Terminal number	53, 54
Modes	Voltage or current
Mode select	software
Voltage level	0–10 V
Input resistance, R_i	approximately 10 k Ω
Maximum voltage	-15 to +20 V
Current level	0/4 to 20 mA (scaleable)
Input resistance, R_i	approximately 200 Ω
Maximum current	30 mA
Resolution for analog inputs	11 bit
Accuracy of analog inputs	Maximum error 0.5% of full scale
Bandwidth	100 Hz

The analog inputs are galvanically isolated from the supply voltage (PELV) and other high-voltage terminals.

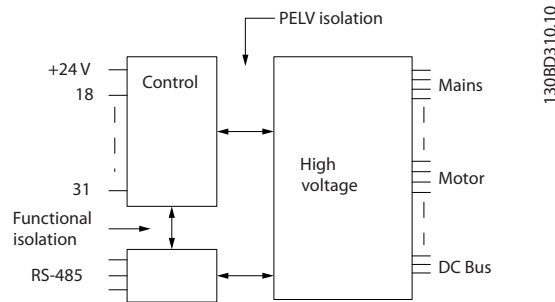

Illustration 8.1 Analog Inputs

Pulse inputs

Programmable pulse inputs	2
Terminal number pulse	29, 33
Maximum frequency at terminal 29, 33	32 kHz (push-pull driven)
Maximum frequency at terminal 29, 33	5 kHz (open collector)
Minimum frequency at terminal 29, 33	4 Hz
Voltage level	See the section on digital input
Maximum voltage on input	28 V DC
Input resistance, R_i	Approximately 4 k Ω
Pulse input accuracy	Maximum error: 0.1% of full scale

Analog outputs

Number of programmable analog outputs	2
Terminal number	45, 42
Current range at analog output	0/4–20 mA
Maximum resistor load to common at analog output	500 Ω
Accuracy on analog output	Maximum error: 0.8% of full scale
Resolution on analog output	10 bit

The analog output is galvanically isolated from the supply voltage (PELV) and other high-voltage terminals.

Control card, RS485 serial communication

Terminal number	68 (PTX+, RX+), 69 (N,TX-, RX-)
Terminal number 61	Common for terminals 68 and 69

The RS485 serial communication circuit is galvanically isolated from the supply voltage (PELV).

Digital outputs

Programmable digital/pulse outputs	2
Terminal number	27, 29 ¹⁾
Voltage level at digital/frequency output	0–24 V
Maximum output current (sink or source)	40 mA
Maximum load at frequency output	1 k Ω
Maximum capacitive load at frequency output	10 nF
Minimum output frequency at frequency output	4 Hz
Maximum output frequency at frequency output	32 kHz
Accuracy of frequency output	Maximum error: 0.1% of full scale
Resolution of frequency output	10 bit

1) Terminal 27 and 29 can also be programmed as input.

The digital output is galvanically isolated from the supply voltage (PELV) and other high-voltage terminals.

Control card, 24 V DC output

Terminal number	12
Maximum load	100 mA

The 24 V DC supply is galvanically isolated from the supply voltage (PELV), but has the same potential as the analog and digital inputs and outputs.

8
Relay outputs

Programmable relay outputs	2
Relay 01 and 02	01–03 (NC), 01–02 (NO), 04–06 (NC), 04–05 (NO)
Maximum terminal load (AC-1) ¹⁾ on 01–02/04–05 (NO) (Resistive load)	250 V AC, 3 A
Maximum terminal load (AC-15) ¹⁾ on 01–02/04–05 (NO) (Inductive load @ $\cos\phi$ 0.4)	250 V AC, 0.2 A
Maximum terminal load (DC-1) ¹⁾ on 01–02/04–05 (NO) (Resistive load)	30 V DC, 2 A
Maximum terminal load (DC-13) ¹⁾ on 01–02/04–05 (NO) (Inductive load)	24 V DC, 0.1 A
Maximum terminal load (AC-1) ¹⁾ on 01–03/04–06 (NC) (Resistive load)	250 V AC, 3 A
Maximum terminal load (AC-15) ¹⁾ on 01–03/04–06 (NC) (Inductive load @ $\cos\phi$ 0.4)	250 V AC, 0.2 A
Maximum terminal load (DC-1) ¹⁾ on 01–03/04–06 (NC) (Resistive load)	30 V DC, 2 A
Minimum terminal load on 01–03 (NC), 01–02 (NO)	24 V DC 10 mA, 24 V AC 20 mA

1) IEC 60947 t 4 and 5

The relay contacts are galvanically isolated from the rest of the circuit by reinforced isolation.

Control card, +10 V DC output

Terminal number	50
Output voltage	10.5 V \pm 0.5 V
Maximum load	15 mA

The 10 V DC supply is galvanically isolated from the supply voltage (PELV) and other high-voltage terminals.

Control characteristics

Resolution of output frequency at 0–500 Hz	\pm 0.003 Hz
System response time (terminals 18, 19, 27, 29, 32, and 33)	\leq 2 ms
Speed control range (open loop)	1:100 of synchronous speed
Speed accuracy (open loop)	\pm 0.5% of nominal speed
Speed accuracy (closed loop)	\pm 0.1% of nominal speed

All control characteristics are based on a 4-pole asynchronous motor.

Ambient conditions

Enclosure sizes J1-J7	IP20
Vibration test, all enclosure sizes	1.0 g
Relative humidity	5-95% (IEC 721-3-3); Class 3K3 (non-condensing) during operation
Aggressive environment (IEC 60068-2-43) H ₂ S test	Class Kd
Test method according to IEC 60068-2-43 H ₂ S (10 days)	
Ambient temperature (at 60 AVM switching mode)	
- with derating	Maximum 55 °C (131 °F) ¹⁾
- at full continuous output current with some power size	Maximum 50 °C (122 °F)
- at full continuous output current	Maximum 45 °C (113 °F)
Minimum ambient temperature during full-scale operation	0 °C (32 °F)
Minimum ambient temperature at reduced performance	-10 °C (14 °F)
Temperature during storage/transport	-25 to +65/70 °C (-13 to +149/158 °F)
Maximum altitude above sea level without derating	1000 m (3281 ft)
Maximum altitude above sea level with derating	3000 m (9843 ft)
EMC standards, emission	EN 61800-3, EN 61000-3-2, EN 61000-3-3, EN 61000-3-11, EN 61000-3-12, EN 61000-6-3/4, EN 55011, IEC 61800-3 EN 61800-3, EN 61000-6-1/2, EN 61000-4-2,
EMC standards, immunity	EN 61000-4-3, EN 61000-4-4, EN 61000-4-5, EN 61000-4-6
Energy efficiency class ¹⁾	IE2

1) Determined according to EN 50598-2 at:

- Rated load.
- 90% rated frequency.
- Switching frequency factory setting.
- Switching pattern factory setting.

Control card performance

Scan interval	1 ms
---------------	------

Protection and features

- Electronic thermal motor protection against overload.
- Temperature monitoring of the heat sink ensures that the frequency converter trips when the temperature reaches a predefined level. An overload temperature cannot be reset until the temperature of the heat sink is below the temperature limit.
- The frequency converter is protected against short circuits on motor terminals U, V, W.
- If a mains phase is missing, the frequency converter trips or issues a warning (depending on the load and parameter setting).
- Monitoring of the intermediate circuit voltage ensures that the frequency converter trips when the intermediate circuit voltage is too low or too high.
- The frequency converter is protected against ground faults on motor terminals U, V, W.

8.3 Fuses

Use fuses and/or circuit breakers on the supply side to protect service personnel and equipment from injuries and damage if there is component breakdown inside the frequency converter (first fault).

Branch circuit protection

Protect all branch circuits in an installation, switchgear, and machines against short circuit and overcurrent according to national/international regulations.

NOTICE

The recommendations do not cover branch circuit protection for UL.

Table 8.4 lists the recommended fuses that have been tested.

Enclosure size	Power [kW (hp)]	CE compliance fuse
J1	0.37–1.1 (0.5–1.5)	gG-10
	1.5 (2)	
	2.2 (3)	
J2	3.0 (4)	gG-25
	4.0 (5.5)	
	5.5 (7.5)	
J3	7.5 (10)	gG-32
J4	11–15 (15–20)	gG-50
J5	18.5 (25)	gG-80
	22 (30)	
J6	30 (40)	gG-125
	37 (50)	
	45 (60)	
J7	55 (75)	aR-250
	75 (100)	

Table 8.4 CE Fuse, 380–480 V, Enclosure Sizes J1–J7

⚠ WARNING

PERSONAL INJURY AND EQUIPMENT DAMAGE RISK
Malfunction or failing to follow the recommendations may result in personal risk and damage to the frequency converter and other equipment.

- Select fuses according to recommendations. Possible damages can be limited to be inside the frequency converter.

NOTICE

Using fuses or circuit breakers is mandatory to ensure compliance with IEC 60364 for CE.

Danfoss recommends using the fuses in Table 8.4 on a circuit capable of delivering 100000 A_{rms} (symmetrical), 380–480 V depending on the frequency converter voltage rating. With the proper fusing, the frequency converter short circuit current rating (SCCR) is 100000 A_{rms}.

8.4 Connection Tightening Torques

Make sure to use the right torques when tightening all electrical connections. Too low or too high torque may cause electrical connection problems. Use a torque wrench to ensure that correct torques are applied.

Enclosure size	Power [kW (hp)]	Torque [Nm (in-lb)]						
		Mains	Motor	DC connection	Brake	Ground	Control	Relay
J1	0.37–2.2 (0.5–3)	0.8 (7.1)	0.8 (7.1)	0.8 (7.1)	0.8 (7.1)	3 (26.6)	0.44 (3.89)	0.5 (4.4)
J2	3.0–5.5 (4–7.5)	0.8 (7.1)	0.8 (7.1)	0.8 (7.1)	0.8 (7.1)	3 (26.6)	0.44 (3.89)	0.5 (4.4)
J3	7.5 (10)	0.8 (7.1)	0.8 (7.1)	0.8 (7.1)	0.8 (7.1)	3 (26.6)	0.44 (3.89)	0.5 (4.4)
J4	11–15 (15–20)	1.2 (10.6)	1.2 (10.6)	1.2 (10.6)	1.2 (10.6)	1.6 (14.2)	0.44 (3.89)	0.5 (4.4)
J5	18.5–22 (25–30)	1.2 (10.6)	1.2 (10.6)	1.2 (10.6)	1.2 (10.6)	1.6 (14.2)	0.44 (3.89)	0.5 (4.4)
J6	30–45 (40–60)	3.5 (31.0)	3.5 (31.0)	3.5 (31.0)	–	1.6 (14.2)	0.44 (3.89)	0.5 (4.4)
J7	55 (75)	12 (106.2)	12 (106.2)	12 (106.2)	–	1.6 (14.2)	0.44 (3.89)	0.5 (4.4)
J7	75 (100)	14 (123.9)	14 (123.9)	14 (123.9)	–	1.6 (14.2)	0.44 (3.89)	0.5 (4.4)

Table 8.5 Tightening Torques

9 Appendix

9.1 Symbols, Abbreviations, and Conventions

°C	Degrees Celsius
°F	Degrees Fahrenheit
AC	Alternating current
AEO	Automatic energy optimization
AWG	American wire gauge
AMA	Automatic motor adaptation
AM motor	Asynchronous motor
DC	Direct current
EMC	Electromagnetic compatibility
ETR	Electronic thermal relay
$f_{M,N}$	Nominal motor frequency
FC	Frequency converter
GLCP	Graphical local control panel
I_{INV}	Rated inverter output current
I_{LIM}	Current limit
$I_{M,N}$	Nominal motor current
$I_{VLT,MAX}$	Maximum output current
$I_{VLT,N}$	Rated output current supplied by the frequency converter
IP	Ingress protection
LCP	Local control panel
MCT	Motion control tool
NLCP	Numerical local control panel
n_s	Synchronous motor speed
$P_{M,N}$	Nominal motor power
PELV	Protective extra low voltage
PCB	Printed circuit board
PM motor	Permanent magnet motor
PWM	Pulse width modulation
RPM	Revolutions per minute
T_{LIM}	Torque limit
$U_{M,N}$	Nominal motor voltage

Table 9.1 Symbols and Abbreviations

Conventions

- For illustrations, all dimensions are in [mm (in)].
- An asterisk (*) indicates the default setting of a parameter.
- Numbered lists indicate procedures.
- Bullet lists indicate other information.
- Italicized text indicates:
 - Cross-reference.
 - Link.
 - Parameter name.

9.2 Parameter Menu Structure

Parameter No.	Parameter Name	Parameter Range	Units	Default	Notes
1-18	18.5 kW - 25 hp	0 - 1000 V *Size related	V	1000 V	
1-19	22 kW - 30 hp	0 - 1000 V *Size related	V	1000 V	
1-20	30 kW - 40 hp	0 - 1000 V *Size related	V	1000 V	
1-21	37 kW - 50 hp	0 - 1000 V *Size related	V	1000 V	
1-22	45 kW - 60 hp	0 - 1000 V *Size related	V	1000 V	
1-23	55 kW - 75 hp	0 - 1000 V *Size related	V	1000 V	
1-24	75 kW - 100 hp	0 - 1000 V *Size related	V	1000 V	
1-25	90 kW - 120 hp	0 - 1000 V *Size related	V	1000 V	
1-26	Motor Voltage	0 - 300 % *100 %	%	100 %	
1-27	50 - 1000 V *Size related	0 - 300 % *100 %	%	100 %	
1-28	Motor Frequency	-400 - 400.0 *Size related	Hz	50 Hz	
1-29	20 - 500 Hz *Size related	0.05 - 5 *0.1 s	s	0.1 s	
1-30	Motor Current	0 - 500 % *100 %	%	100 %	
1-31	Motor Nominal Speed	0 - 500 % *100 %	%	100 %	
1-32	50 - 6000 RPM *Size related	0.001 - 0.05 s *0.005 s	s	0.05 s	
1-33	Motor Cont. Rated Torque	0 - 150 % *50 %	%	50 %	
1-34	0.1 - 10000.0 Nm *Size related	0 - 120 % *50 %	%	50 %	
1-35	Automatic Motor Adaption (AMA)	0 - 10 s *0 s	s	0 s	
1-36	Off	0 - 10 s *0 s	s	0 s	
1-37	Enable Complete AMA	0 - 10 s *0 s	s	0 s	
1-38	Enable Reduced AMA	0 - 10 s *0 s	s	0 s	
1-39	Adv. Motor Data I	0 - 10 s *0 s	s	0 s	
1-40	Stator Resistance (Rs)	0.0 - 9999.000 Ohm *Size related	Ohm	0 Ohm	
1-41	Rotor Resistance (Rr)	0 - 9999.000 Ohm *Size related	Ohm	0 Ohm	
1-42	Stator Leakage Reactance (X1)	0 - 9999.000 Ohm *Size related	Ohm	0 Ohm	
1-43	Main Reactance (Xh)	0.0 - 9999.000 Ohm *Size related	Ohm	0 Ohm	
1-44	d-axis Inductance (Ld)	0 - 65535 mH *Size related	mH	0 mH	
1-45	q-axis Inductance (Lq)	0.000 - 65535 mH *Size related	mH	0 mH	
1-46	Motor Poles	2 - 100 *Size related		2	
1-47	Adv. Motor Data II	0 - 5000 Hz *Size related	Hz	0 Hz	
1-48	Back EMF at 1000 RPM	0 - 1000 A *Size related	A	0 A	
1-49	1 - 9000 V *Size related	0 - 1000 A *Size related	A	0 A	
1-50	Motor Cable Length	0 - 500 Hz *0 Hz	Hz	0 Hz	
1-51	0 - 100 m *50 m	Compressor Start Max Time to Trip	s	0 s	
1-52	Motor Cable Length Feet	0 - 500 Hz *0 Hz	Hz	0 Hz	
1-53	0 - 328 ft *164 ft	Compressor Start Max Time to Trip	s	0 s	
1-54	d-axis Inductance Sat. (LdSat)	0 - 10 s *5 s	s	0 s	
1-55	0 - 65535 mH *Size related	Stop Adjustments			
1-56	q-axis Inductance Sat. (LqSat)	Function at Stop			
1-57	0 - 65535 mH *Size related	Coast			
1-58	Position Detection Gain	DC hold / Motor Preheat			
1-59	200 - 200 % *100 %	Pre-magnetizing			
1-60	Current at Min Inductance for d-axis	Min Speed for Function at Stop [Hz]	Hz	0 Hz	
1-61	200 - 200 % *100 %	0 - 500 Hz *0 Hz	Hz	0 Hz	
1-62	Current at Min Inductance for q-axis	AC Brake Gain			
1-63	200 - 200 % *100 %	1.0 - 2.0 *1.4			
1-64	Load Indep. Setting	Motor Temperature			
1-65	Motor Magnetisation at Zero Speed	Motor Thermal Protection			
1-66	0 - 300 % *100 %	No protection			
1-67	Min Speed Normal Magnetising [Hz]	Thermistor warning			
1-68	0.1 - 10.0 Hz *1 Hz	Thermistor trip			
3-10	Preset Reference	ETR warning 1			
3-11	-100 - 100 % *0 %	ETR trip 1			
3-12	Jog Speed [Hz]	ETR Trip - Extended Detection	Hz		
3-13	0 - 5000.0 Hz *5 Hz	Thermistor Source	Hz		
3-14	Catch up/slow Down Value	None			
3-15	0 - 100 % *0 %	Analog Input 53	1/min		
3-16	Preset Relative Reference	Analog Input 54	Pulse/s		
3-17	-100 - 100 % *0 %	Digital input 18	l/s		
3-18	Reference 1 Source	Digital input 19	l/min		
3-19	No function	Digital input 32	l/h		
3-20	Analog Input 53	Digital input 33	m ³ /s		
3-21	Analog Input 54	Digital input 31	m ³ /min		
3-22	Frequency input 29	Brakes	m ³ /h		
3-23	Frequency input 33	DC Brake	kg/min		
3-24	Local bus reference	DC Hold/Motor Preheat Current	kg/min		
3-25	Digital pot-meter	0 - 160 % *50 %	kg/h		
3-26	Bus PC D	DC Brake Current	t/min		
3-27	Reference 2 Source	0 - 150 % *50 %	t/h		
3-28	Same choices with 3-15	DC Braking Time	m/s		
3-29	Analog Input 54	0 - 60 s *10 s	m/min		
3-30	Reference 3 Source	DC Brake Cut In Speed	m		
3-31	Local bus reference	0 - 500 Hz *0 Hz	°C		
3-32	Relative Scaling Reference Resource	Parking Current	mbar		
3-33	No function	0 - 150 % *100 %	bar		
3-34	Analog Input 53	Parking Time	Pa		
3-35	Analog Input 54	0.1 - 60 s *3 s	kPa		
3-36	Frequency input 29	Brake Energy Funct.	m WG		
3-37	Frequency input 33	Brake Function	kW		
3-38	Local bus reference	Off	GPM		
3-39	Ramp 1	Resistor brake	gal/s		
3-40	Ramp 1 Type	AC brake	gal/min		
3-41	Linear	Brake Resistor (ohm)	gal/h		
3-42	Sine 2 Ramp	0 - 6200 Ohm *Size related	CFM		
3-43	Ramp 1 Ramp Up Time	Brake Power Limit (kW)	ft ³ /min		
3-44	0.01 - 3600 s *Size related	0.001 - 2000 kW *Size related	ft ³ /h		
3-45	Ramp 1 Ramp Down Time	Brake voltage reduce	lb/s		
3-46	0.01 - 3600 s *Size related	0 - 500 V *0 V	lb/min		
3-47	Ramp 2	AC Brake, Max current	lb/h		
3-48	Same content with 3-4*	0 - 160 % *100 %	ft/s		
3-49	Ramp 3	Over-voltage Control	ft/min		
3-50	Same content with 3-4*	Disabled	ft		
3-51	Ramp 4	Enabled (not at stop)	°F		
3-52	Same content with 3-4*	Enabled	psi		
3-53	Other Ramps	Over-voltage Gain			
3-54	Jog Ramp Time	0 - 200 % *100 %	in/in2		
3-55	0.01 - 3600 s *Size related	Mechanical Brake	in WG		
3-56	Quick Stop Ramp Time	Release Brake Current	ft WG		
3-57	0.01 - 3600 s *Size related	0 - 100 A *0 A	HP		
3-58	Digital Pot.Meter	Activate Brake Speed [Hz]	3-02		
3-59	Step Size	0 - 400 Hz *0 Hz			
3-60	0.01 - 200 % *0.10 %	Activate Brake Delay			
3-61	Power Restore	0 - 5 s *0 s			
3-62	Off	Reference / Ramps			
3-63	On	Reference Limits			
3-64	Maximum Limit	3-00 Reference Range			
3-65	Minimum Limit	Min - Max			
3-66	-200 - 200 % *100 %	-Max - +Max			
3-67	Minimum Limit	Reference/Feedback Unit			
3-68	-200 - 200 % *100 %	None			

3-95	Ramp Delay	0 - 3600000 ms *1000 ms	81	SL digital output B
4-1*	Limits / Warnings		82	SL digital output C
4-10	Motor Speed Direction	0 - 500.00 A *Size related Warning Reference Low -4999 - 4999 *4999	83	SL digital output D
[0]	Clockwise	Warning Reference High -4999 - 4999 *4999	91	Encoder emulate output A
*[2]	Both directions	Warning Feedback Low -4999 - 4999 ProcessCtrlUnit *4999	161	No alarm
4-12	Motor Speed Low Limit [Hz]	ProcessCtrlUnit	165	Running reverse
4-14	Motor Speed High Limit [Hz]	Warning Feedback High -4999 - 4999 ProcessCtrlUnit *4999	166	Local ref active
4-16	Torque Limit Motor Mode	ProcessCtrlUnit	167	Remote ref active
4-17	Torque Limit Generator Mode	Missing Motor Phase Function *[1] Off	168	Start command activ
4-18	Current Limit	Speed Bypass	169	Drive in hand mode
4-19	Max Output Frequency	Bypass Speed From [Hz] 0 - 500 Hz *0 Hz	170	Drive in auto mode
4-2*	Limit Factors	Bypass Speed To [Hz] 0 - 500 Hz *Size related	171	Homing Completed
4-20	Torque Limit Factor Source	Digital In/Out	172	Target Position Reached
[0]	No function	Digital I/O Mode	173	Position Control Fault
[2]	Analog in 53	5-00 Digital Input Mode	174	Position Mech Brake
[4]	Analog in 53 inv	*[0] NPN	175	TLD indicator
[6]	Analog in 54	[1] NPN	176	Running on tension
[8]	Analog in 54 inv	5-01 Terminal 27 Mode	177	Ready to run
4-21	Speed Limit Factor Source	*[0] Input	178	End of roll
[0]	No function	[1] Output	193	Sleep Mode
[2]	Analog in 53	5-02 Terminal 29 Mode	194	Broken Belt Function
[4]	Analog in 53 inv	*[0] Output	5-31	Terminal 29 Digital Output
[6]	Analog in 54	5-1* Digital Inputs		Same choices with 5-30
[8]	Analog in 54 inv	5-10 Terminal 18 Digital Input		No operation
4-22	Break Away Boost	[0] No operation	5-34	On Delay, Digital Output
[0]	Off	[1] Reset		0 - 600 s *0.01 s
[1]	On	[2] Coast inverse	5-35	Off Delay, Digital Output
4-3*	Motor Fb Monitor	[3] Coast and reset inverse		0 - 600 s *0.01 s
4-30	Motor Feedback Loss Function	[4] Quick stop inverse		Relays
[0]	Disabled	[5] DC-brake inverse	5-40	Function Relay
[1]	Warning	[6] Stop inverse	[0]	No operation
[2]	Trip	*[8] Start	[1]	Control Ready
[3]	Jog	[9] Latched start	[2]	Drive ready
[4]	Freeze Output	[10] Reversing	[3]	Drive rdy/rem ctrl
[5]	Max Speed	[11] Start reversing	[4]	Stand-by / no warning
[6]	Switch to Open Loop	[12] Enable start forward	[5]	Running
4-31	Motor Feedback Speed Error	[13] Enable start reverse	[6]	Running / no warning
4-32	Motor Feedback Loss Timeout	[14] Jog	[7]	Run in range/no warn
4-4*	Adj. Warnings 2	[15] Preset reference on	[8]	Run on ref/no warn
4-40	Warning Freq. Low	[16] Preset ref bit 0	[9]	Alarm
4-41	Warning Freq. High	[17] Preset ref bit 1	[10]	Alarm or warning
4-42	Adjustable Temperature Warning	[18] Preset ref bit 2	[11]	At torque limit
4-5*	Adj. Warnings	[19] Freeze reference	[12]	Out of current range
4-50	Warning Current Low	[20] Freeze output	[13]	Below current, low
4-51	Warning Current High	[21] Speed up	[14]	Below current, high
		[22] Speed down	[15]	Out of frequency range
		[23] Set-up select bit 0	[16]	Below frequency, low
		[26] Catch up	[17]	Below frequency, high
		[28] Slow down	[18]	Out of feedb. range
		[29] Ramp bit 0	[19]	Below feedback, low
			[20]	Below feedback, high
			[21]	Thermal warning
			[22]	Ready, no thermal warning
			[23]	Remote,ready,no TW
			[24]	Ready, no over-/ under voltage
			[25]	Reverse
			[26]	Bus OK
			[27]	Torque limit & stop
			[28]	Brake, no brake warning
				SL digital output A

[29]	Brake ready, no fault	5-56	Term. 33 High Frequency	6-11	Terminal 53 High Voltage	[4]	Stand-by / no warning	[168]	Drive in hand mode
[30]	Brake fault (IGBT)	5-57	5 - 32000 Hz *32000 Hz	6-12	0 - 10 V *10 V	[5]	Running	[169]	Drive in auto mode
[31]	Relay 123	5-58	Term. 33 Low Ref./Feedb. Value	6-13	Terminal 53 Low Current	[6]	Running / no warning	[170]	Homing Completed
[32]	Mech brake ctrl	5-59	Term. 33 High Ref./Feedb. Value	6-14	0 - 20 mA *4 mA	[7]	Run in range/no warn	[171]	Target Position Reached
[36]	Control word bit 11	5-60	Term. 33 Low Ref./Feedb. Value	6-15	Terminal 53 High Current	[8]	Run on ref/no warn	[172]	Position Control Fault
[37]	Control word bit 12	5-61	-4999 - 4999 *Size related	6-16	0 - 20 mA *20 mA	[9]	Alarm	[173]	Position Mech Brake
[40]	Out of ref range	5-62	Pulse Output	6-17	Terminal 53 Low Ref./Feedb. Value	[10]	Alarm or warning	[174]	TLD indicator
[41]	Below reference, low	5-63	Terminal 27 Pulse Output Variable	6-18	Terminal 53 High Ref./Feedb. Value	[11]	At torque limit	[175]	Running on tension
[42]	Above ref, high	5-64	No operation	6-19	Terminal 53 High Ref./Feedb. Value	[12]	Out of current range	[176]	Ready to run
[45]	Bus ctrl.	5-65	Bus ctrl., timeout	6-20	-4999 - 4999 *Size related	[13]	Below current, low	[177]	End of roll
[46]	Bus control, timeout: On	5-66	Output frequency	6-21	Terminal 53 Filter Time Constant	[14]	Above current, high	[193]	Sleep Mode
[47]	Bus control, timeout: Off	5-67	Reference	6-22	0.01 - 10 s *0.01 s	[15]	Out of frequency range	[194]	Broken Belt Function
[56]	Heat sink cleaning warning, high	5-68	Motor Current	6-23	Terminal 53 mode	[16]	Below frequency, low	[198]	Drive Bypass
[60]	Comparator 0	5-69	Torque rel to limit	6-24	Terminal 53 mode	[17]	Above frequency, high	6-73	Terminal 45 Output Min Scale
[61]	Comparator 1	5-70	Torque relate to rated	6-25	0.01 - 10 s *0.01 s	[18]	Out of feedb. range	6-74	Terminal 45 Output Max Scale
[62]	Comparator 2	5-71	Power	6-26	Terminal 54 Low Voltage	[19]	Below feedback, low	6-76	Terminal 45 Output Bus Control
[63]	Comparator 3	5-72	Speed	6-27	0 - 10 V *0.07 V	[20]	Above feedback, high	6-9*	Analog/Digital Output 42
[64]	Comparator 4	5-73	Max Out Freq	6-28	Terminal 54 High Voltage	[21]	Thermal warning	6-90	Terminal 42 Mode
[65]	Comparator 5	5-74	PID Clamped Output	6-29	Terminal 54 Low Voltage	[22]	Ready, no thermal warning	[1]	4-20 mA
[70]	Logic rule 0	5-75	Pulse Output Max Freq 27	6-30	Terminal 54 High Current	[23]	Remote,ready,no TW	[2]	Digital Output
[71]	Logic rule 1	5-76	4 - 32000 Hz *5000 Hz	6-31	Terminal 54 Low Current	[24]	Ready, no over-/ under voltage	6-91	Terminal 42 Analog Output
[72]	Logic rule 2	5-77	4 - 32000 Hz *5000 Hz	6-32	Terminal 54 High Current	[25]	Reverse	*[0]	No operation
[73]	Logic rule 3	5-78	Terminal 29 Pulse Output Variable	6-33	Terminal 54 High Current	[26]	Bus OK	[100]	Output frequency
[74]	Logic rule 4	5-79	Same choices with 5-60	6-34	0 - 20 mA *20 mA	[27]	Torque limit & stop	[101]	Reference
[75]	Logic rule 5	5-80	No operation	6-35	Terminal 54 Low Ref./Feedb. Value	[28]	Brake, no brake warning	[102]	Process Feedback
[80]	SL digital output A	5-81	Pulse Output Max Freq 29	6-36	Terminal 54 High Ref./Feedb. Value	[29]	Brake ready, no fault	[103]	Motor Current
[81]	SL digital output B	5-82	4 - 32000 Hz *5000 Hz	6-37	-4999 - 4999 *Size related	[30]	Brake fault (IGBT)	[104]	Torque rel to limit
[82]	SL digital output C	5-83	24V Encoder Input	6-38	Terminal 54 Filter Time Constant	[31]	Relay 123	[105]	Torque relate to rated
[83]	SL digital output D	5-84	Term 32/33 Pulses Per Revolution	6-39	0.01 - 10 s *0.01 s	[32]	Mech brake ctrl	[106]	Power
[160]	No alarm	5-85	1 - 4096 *1024	6-40	Terminal 54 mode	[36]	Control word bit 11	[107]	Speed
[161]	Running reverse	5-86	Term 32/33 Encoder Direction	6-41	Current mode	[40]	Control word bit 12	[111]	Speed Feedback
[165]	Local ref active	5-87	Clockwise	6-42	Terminal 54 mode	[37]	Out of ref range	[113]	PID Clamped Output
[166]	Remote ref active	5-88	Clockwise	6-43	Voltage mode	[41]	Below reference, low	[139]	Bus Control
[167]	Start command active	5-89	Bus Controlled	6-44	Analog/Digital Output 45	[42]	Above ref, high	[143]	Ext. CL 1
[168]	Drive in hand mode	5-90	Digital & Relay Bus Control	6-45	Terminal 45 Mode	[45]	Bus ctrl.	[162]	Tapered tension set point
[169]	Drive in auto mode	5-91	0 - 0xFFFFFFF *0	6-46	0-20 mA	[46]	Bus control, timeout: On	[254]	DC Link Voltage
[170]	Homing Completed	5-92	Pulse Out 27 Bus Control	6-47	4-20 mA	[47]	Bus control, timeout: Off	6-92	Terminal 42 Digital Output
[171]	Target Position Reached	5-93	0 - 100 % *0 %	6-48	Digital Output	[56]	Heat sink cleaning warning, high	*[0]	No operation
[172]	Position Control Fault	5-94	0 - 100 % *0 %	6-49	Terminal 45 Analog Output	[60]	Comparator 0	[1]	Control Ready
[173]	Position Mech Brake	5-95	Pulse Out 29 Bus Control	6-50	Output frequency	[61]	Comparator 1	[2]	Drive ready
[175]	Running on tension	5-96	Pulse Out 27 Timeout Preset	6-51	Reference	[62]	Comparator 2	[3]	Drive rdy/rem ctrl
[176]	Ready to run	5-97	0 - 100 % *0 %	6-52	Process Feedback	[63]	Comparator 3	[4]	Stand-by / no warning
[193]	Sleep Mode	5-98	0 - 100 % *0 %	6-53	Motor Current	[64]	Comparator 4	[5]	Running
[194]	Broken Belt Function	5-99	Pulse Out 29 Timeout Preset	6-54	Torque rel to limit	[65]	Comparator 5	[6]	Running / no warning
5-41	On Delay, Relay	6-0*	0 - 100 % *0 %	6-55	Torque relate to rated	[70]	Logic rule 0	[7]	Run in range/no warn
5-42	Off Delay, Relay	6-1*	Analog In/Out	6-56	Power	[71]	Logic rule 1	[8]	Run on ref/no warn
5-50	Pulse Input	6-2*	Analog I/O Mode	6-57	Speed	[72]	Logic rule 2	[9]	Alarm
5-50	Term. 29 Low Frequency	6-3*	Live Zero Timeout Time	6-58	[107] Speed	[73]	Logic rule 3	[10]	Alarm or warning
5-51	Term. 29 High Frequency	6-4*	1 - 99 s *10 s	6-59	[111] Speed Feedback	[74]	Logic rule 4	[11]	Alarm at torque limit
5-52	Term. 29 Low Ref./Feedb. Value	6-5*	Live Zero Timeout Function	6-60	[113] PID Clamped Output	[75]	Logic rule 5	[12]	Out of current range
5-52	Term. 29 High Ref./Feedb. Value	6-6*	Off	6-61	[139] Bus Control	[80]	SL digital output A	[13]	Below current, low
5-53	Term. 29 High Ref./Feedb. Value	6-7*	Freeze output	6-62	[143] Ext. CL 1	[81]	SL digital output B	[14]	Above current, high
5-55	Term. 33 Low Frequency	6-8*	Stop	6-63	[162] Tapered tension set point	[82]	SL digital output C	[15]	Out of frequency range
		6-9*	Jogging	6-64	[254] DC Link Voltage	[83]	SL digital output D	[16]	Below frequency, low
		6-10	Max. speed	6-65	6-72 Terminal 45 Digital Output	[160]	No alarm	[17]	Above frequency, high
			Stop and trip	6-66	*[0] No operation	[161]	Running reverse		
			Term. 29 High Ref./Feedb. Value	6-67	[1] Control Ready	[165]	Local ref active		
			Term. 33 Low Frequency	6-68	[2] Drive ready	[166]	Remote ref active		
			4 - 31999 Hz *4 Hz	6-69	[3] Drive rdy/rem ctrl	[167]	Start command active		

[18]	Out of feedb. range	0 - 200 % *0 %	7-34	Process PID Integral Time	[1]	Square root	8-36	Maximum Response Delay
[19]	Below feedback, low	Terminal 42 Output Max Scale	7-35	0:10 - 9999 s *9999 s	[8-33]	Comm. and Options	0.1 - 10.0 s *Size related	
[20]	Above feedback, high	0 - 200 % *100 %	7-36	Process PID Differentiation Time	[8-33]	General Settings	FC MC protocol set	
[21]	Thermal warning	Terminal 42 Output Bus Control	7-37	Process PID Diff. Gain Limit	[8-42]	Control Site	PCD Write Configuration	
[22]	Ready, no thermal warning	0 - 16384 *0	7-38	Process PID Feed Forward Factor	[0]	None	[0] None	
[23]	Remote,ready/no TW	7-33 Controllers	7-39	Process PID Feed Forward Factor	[1]	Digital and ctrl.word	[1] [302] Minimum Reference	
[24]	Ready, no over-/ under voltage	Speed PID Ctrl.	7-40	Process PID Feed Forward Factor	[2]	Controlword only	[2] [303] Maximum Reference	
[25]	Reverse	Speed PID Feedback Source	7-41	On Reference Bandwidth	[8-02]	Control Source	[3] [341] Ramp 1 Ramp up time	
[26]	Bus OK	[1] 24V encoder	7-42	Process PID Gain Scale at Min. Ref.	[0]	None	[4] [342] Ramp 1 Ramp down time	
[27]	Torque limit & stop	[2] MCB 102	7-43	Process PID Gain Scale at Max. Ref.	[1]	FC Port	[5] [351] Ramp 2 Ramp up time	
[28]	Brake, no brake warning	[3] MCB 103	7-44	Process PID Feed Fwd Resource	[3]	Option A	[6] [352] Ramp 2 Ramp down time	
[29]	Brake ready, no fault	[6] Analog Input 53	7-45	No function	[8-03]	Control Timeout Time	[7] [380] Jog Ramp Time	
[30]	Brake fault (IGBT)	[7] Analog Input 54	7-46	Analog Input 53	[8-04]	Control Timeout Function	[8] [381] Quick Stop Time	
[31]	Relay 123	[8] Frequency input 29	7-47	Analog Input 54	[*0]	Off	[9] [412] Motor Speed Low Limit [Hz]	
[32]	Mech brake ctrl	[9] Frequency input 33	7-48	Frequency input 29	[1]	Freeze output	[10] [414] Motor Speed High Limit [Hz]	
[36]	Control word bit 11	[*20] None	7-49	Frequency input 33	[1]	Stop	[11] [590] Digital & Relay Bus Control	
[37]	Control word bit 12	0 - 1 *0.015	7-50	Local bus reference	[2]	Jogging	[12] [676] Terminal45 Output Bus Control	
[40]	Out of ref range	Speed PID Proportional Gain	7-51	Bus PC2	[3]	Max. speed	[13] [696] Terminal 42 Output Bus Control	
[41]	Below reference, low	Speed PID Integral Time	7-52	Process PID Feed Fwd Normal/ Inv. Ctrl.	[4]	Max. speed	[15] FC Port CTW	
[42]	Above ref. high	2 - 20000 ms *8 ms	7-53	Process PID Feed Fwd Resource	[5]	Stop and trip	[16] FC Port REF	
[45]	Bus ctrl.	Speed PID Differentiation Time	7-54	Process PID Feed Fwd Resource	[8-07]	Diagnosis Trigger	[18] [311] Jog Speed [Hz]	
[46]	Bus control, timeout: On	0 - 200 ms *30 ms	7-55	No function	[*0]	Disable	[8-43] PCD Read Configuration	
[47]	Bus control, timeout: Off	Speed PID Diff. Gain Limit	7-56	Process PID Feed Fwd Resource	[1]	Trigger on alarms	[0] None	
[56]	Heat sink cleaning warning, high	1 - 20 *5	7-57	Process PID Feed Fwd Resource	[2]	Trigger alarm/warn.	[1] [1500] Operation Hours	
[60]	Comparator 0	Speed PID Lowpass Filter Time	7-58	Normal	[8-1*	Ctrl. Word Settings	[2] [1501] Running Hours	
[61]	Comparator 1	1 - 6000 ms *10 ms	7-59	Normal	[8-10]	Ctrl. Word Profile	[3] [1502] kWh Counter	
[62]	Comparator 2	Speed PID Feedback Gear Ratio	7-60	PCD Feed Forward	[*0]	FC profile	[4] [1600] Control Word	
[63]	Comparator 3	0.0001 - 32 *1	7-61	Process PID Feed Fwd Resource	[1]	PROFdrive profile	[5] [1601] Reference [Unit]	
[64]	Comparator 4	Speed PID Feed Forward Factor	7-62	Process PID Feed Fwd Resource	[8-14]	Configurable Control Word CTW	[6] [1602] Reference %	
[65]	Comparator 5	0 - 500 % *0 %	7-63	Process PID Feed Fwd Resource	[0]	None	[7] [1603] Status Word	
[70]	Logic rule 0	7-1* Torque PID Ctrl.	7-64	Process PID Feed Fwd Resource	[*1]	Profile default	[8] [1605] Main Actual Value [%]	
[71]	Logic rule 1	Torque PID Proportional Gain	7-65	Process PID Feed Fwd Resource	[2]	CTW Valid, active low	[9] [1609] Custom Readout	
[72]	Logic rule 2	0 - 500 % *100 %	7-66	Process PID Feed Fwd Resource	[4]	PID error inverse	[10] [1610] Power [kW]	
[73]	Logic rule 3	Torque PID Integration Time	7-67	Process PID Feed Fwd Resource	[5]	PID reset 1 part	[11] [1611] Power [hp]	
[74]	Logic rule 4	0.002 - 2 s *0.020 s	7-68	Process PID Feed Fwd Resource	[6]	PID enable	[12] [1612] Motor Voltage	
[75]	Logic rule 5	7-2* Process Ctrl. Feedb	7-69	Process PID Feed Fwd Resource	[8-19]	Product Code	[13] [1613] Frequency	
[80]	SL digital output A	7-20 Process CL Feedback 1 Resource	7-70	Process PID Feed Fwd Resource	[8-33]	FC Port Settings	[14] [1614] Motor Current	
[81]	SL digital output B	[*0] No function	7-71	Process PID Feed Fwd Resource	[8-30]	Protocol	[15] [1615] Frequency [%]	
[82]	SL digital output C	[1] Analog Input 53	7-72	Process PID Feed Fwd Resource	[2]	Torque [Nm]	[16] [1616] Torque [Nm]	
[83]	SL digital output D	[2] Analog Input 54	7-73	Process PID Feed Fwd Resource	[*0]	FC	[17] [1618] Motor Thermal	
[160]	No alarm	[3] Frequency input 29	7-74	Process PID Feed Fwd Resource	[2]	Modbus RTU	[18] [1630] DC Link Voltage	
[161]	Running reverse	[4] Frequency input 33	7-75	Process PID Feed Fwd Resource	[8-31]	Address	[19] [1634] Heatsink Temp.	
[165]	Local ref active	[*0] No function	7-76	Process PID Feed Fwd Resource	[0]	0.0 - 247 *1	[20] [1635] Inverter Thermal	
[166]	Remote ref active	Speed PID Feedback 2 Resource	7-77	Process PID Feed Fwd Resource	[8-32]	Baud Rate	[21] [1638] SL Controller State	
[167]	Start command active	[1] Analog Input 53	7-78	Process PID Feed Fwd Resource	[0]	2400 Baud	[22] [1650] External Reference	
[168]	Drive in hand mode	[2] Analog Input 54	7-79	Process PID Feed Fwd Resource	[1]	4800 Baud	[23] [1652] Feedback [Unit]	
[169]	Drive in auto mode	[3] Frequency input 29	7-80	Process PID Feed Fwd Resource	[1]	9600 Baud	[24] [1660] Digital Input 18,19,27,33	
[170]	Homing Completed	[4] Frequency input 33	7-81	Process PID Feed Fwd Resource	[3]	19200 Baud	[25] [1661] Terminal 53 Switch Setting	
[171]	Target Position Reached	7-3* Process PID Ctrl.	7-82	Process PID Feed Fwd Resource	[4]	38400 Baud	[26] [1662] Analog input 53	
[172]	Position Control Fault	Process PID Normal/ Inverse Control	7-83	Process PID Feed Fwd Resource	[5]	57600 Baud	[27] [1663] Terminal 54 Switch Setting	
[173]	Position Mech Brake	[*0] Normal	7-84	Process PID Feed Fwd Resource	[6]	76800 Baud	[28] [1664] Analog input 54	
[174]	TLD indicator	[1] Inverse	7-85	Process PID Feed Fwd Resource	[7]	115200 Baud	[29] [1665] Relay output 42 [mA]	
[175]	Running on tension	Process PID Anti Windup	7-86	Process PID Feed Fwd Resource	[8-33]	Parity / Stop Bits	[30] [1671] Relay output	
[176]	Ready to run	[0] Off	7-87	Process PID Feed Fwd Resource	[0]	Even Parity, 1 Stop Bit	[31] [1672] Counter A	
[177]	End of roll	[*1] On	7-88	Process PID Feed Fwd Resource	[1]	Odd Parity, 1 Stop Bit	[32] [1673] Counter B	
[193]	Sleep Mode	Process PID Start Speed	7-89	Process PID Feed Fwd Resource	[2]	No Parity, 1 Stop Bit	[33] [1690] Alarm Word	
[194]	Broken Belt Function	0 - 6000 RPM *0 RPM	7-90	Process PID Feed Fwd Resource	[3]	No Parity, 2 Stop Bits	[34] [1692] Warning Word	
[198]	Drive Bypass	Process PID Proportional Gain	7-91	Process PID Feed Fwd Resource	[*0]	Minimum Response Delay	[35] [1694] Ext. Status Word	
6-93	Terminal 42 Output Min Scale	0 - 10 *0.01	7-92	Process PID Feed Fwd Resource	[*0]	Linear	[38] [1622] Torque [%]	

[41]	[1657] Feedback [RPM]	0 - 4294967295 *0	[1500] Operating hours	[3428] PCD 8 Read For Application	[1605] Main Actual Value [%]
[42]	[1679] Analog Output 45 [mA]	Slave Messages Sent	[1501] Running Hours	[3429] PCD 9 Read For Application	[1609] Custom Readout
8-5*	Digital/Bus	0 - 4294967295 *0	[1502] kWh Counter	[3430] PCD 10 Read For Application	[1610] Power [kW]
8-50	Coasting Select	Slave Timeout Errors	[1600] Control Word	[3450] Actual Position	[1611] Power [hp]
[1]	Digital input	0 - 4294967295 *0	[1601] Reference [Unit]	[3456] Track Error	[1612] Motor Voltage
[2]	Bus	Reset FC port Diagnostics	[1602] Reference [%]	9-18 Node Address	[1613] Frequency
[3]	Logic AND	Do not reset	[1603] Status Word	1 - 126 *126	[1614] Motor current
8-51	Quick Stop Select	Bus Feedback	[1605] Main Actual Value [%]	9-19 Drive Unit System Number	[1615] Frequency [%]
[1]	Bus	0 - 1500 RPM *100 RPM	[1609] Custom Readout	0 - 65535 *1037	[1616] Torque [Nm]
[2]	Logic AND	Bus Jog 1 Speed	[1610] Power [kW]	9-22 Telegram Selection	[1617] Speed [RPM]
8-52	DC Brake Select	0 - 1500 RPM *100 RPM	[1611] Power [hp]	[1] Standard telegram 1	[1618] Motor Thermal
[1]	Bus	Bus Jog 2 Speed	[1612] Motor Voltage	*[100] None	[1622] Torque [%]
[2]	Logic AND	9-** PROFIdrive	[1613] Frequency	[101] PPO 1	[1630] DC Link Voltage
[3]	Logic OR	9-15 PCD Write Configuration	[1615] Frequency [%]	[102] PPO 2	[1633] Brake Energy /2 min
[1]	Bus	[0] None	[1616] Torque [Nm]	[103] PPO 3	[1634] Heatsink Temp.
[2]	Logic AND	[302] Minimum Reference	[1617] Speed [RPM]	[104] PPO 4	[1635] Inverter Thermal
[3]	Logic OR	[303] Maximum Reference	[1618] Motor Thermal	[105] PPO 5	[1638] SL Controller State
8-53	Start Select	[311] Jog Speed [Hz]	[1622] Torque [%]	[106] PPO 6	[1639] Control Card Temp.
[0]	Digital input	[312] Catch up/slow Down Value	[1630] DC Link Voltage	[107] PPO 7	[1650] External Reference
[1]	Bus	[341] Ramp 1 Ramp Up Time	[1633] Brake Energy /2 min	[108] PPO 8	[1652] Feedback[Unit]
[2]	Logic AND	[342] Ramp 1 Ramp Down Time	[1634] Heatsink Temp.	[200] Custom telegram 1	[1653] Digi Pot Reference
[3]	Logic OR	[351] Ramp 2 Ramp Up Time	[1635] Inverter Thermal	9-23 Parameters for Signals	[1657] Feedback [RPM]
8-54	Reversing Select	[352] Ramp 2 Ramp Down Time	[1638] SL Controller State	*[0] None	[1660] Digital Input
[0]	Digital input	[380] Jog Ramp Time	[1639] Control Card Temp.	[302] Minimum Reference	[1661] Terminal 53 Setting
[1]	Bus	[381] Quick Stop Ramp Time	[1650] External Reference	[303] Maximum Reference	[1662] Analog input 53
[2]	Logic AND	[412] Motor Speed Low Limit [Hz]	[1652] Feedback[Unit]	[311] Jog Speed [Hz]	[1663] Terminal 54 Setting
[3]	Logic OR	[414] Motor Speed High Limit [Hz]	[1653] Digi Pot Reference	[312] Catch up/slow Down Value	[1664] Analog input 54
8-55	Set-up Select	[416] Torque Limit Motor Mode	[1657] Feedback [RPM]	[341] Ramp 1 Ramp Up Time	[1665] Analog output 42 [mA]
[0]	Digital input	[417] Torque Limit Generator Mode	[1660] Digital Input	[342] Ramp 1 Ramp Down Time	[1667] Pulse input 29 [Hz]
[1]	Bus	[553] Term. 29 High Ref./Feedb. Value	[1661] Terminal 53 Setting	[351] Ramp 2 Ramp Up Time	[1668] Pulse input 33 [Hz]
[2]	Logic AND	[558] Term. 33 High Ref./Feedb. Value	[1662] Analog input 53	[352] Ramp 2 Ramp Down Time	[1669] Pulse output 27 [Hz]
[3]	Logic OR	[590] Digital & Relay Bus Control	[1663] Terminal 54 Setting	[380] Jog Ramp Time	[1670] Pulse output 29 [Hz]
8-56	Preset Reference Select	[593] Digital & Relay Bus Control	[1664] Analog output 42 [mA]	[381] Quick Stop Ramp Time	[1671] Relay output
[0]	Digital input	[595] Pulse Out 27 Bus Control	[1665] Analog output 42 [mA]	[412] Motor Speed Low Limit [Hz]	[1672] Counter A
[1]	Bus	[595] Pulse Out 29 Bus Control	[1667] Pulse input 29 [Hz]	[414] Motor Speed High Limit [Hz]	[1673] Counter B
[2]	Logic AND	[615] Terminal 53 High Ref./Feedb. Value	[1668] Pulse input 33 [Hz]	[416] Torque Limit Motor Mode	[1679] Analog output 45 [mA]
[3]	Logic OR	[625] Terminal 54 High Ref./Feedb. Value	[1669] Pulse output 27 [Hz]	[417] Torque Limit Generator Mode	[1680] Fieldbus CTW 1
8-57	Profidrive OFF2 Select	[676] Terminal 45 Output Bus Control	[1670] Pulse output 29 [Hz]	[553] Term. 29 High Ref./Feedb. Value	[1682] Fieldbus REF 1
[0]	Digital input	[696] Terminal 42 Output Bus Control	[1671] Relay output	[558] Term. 33 High Ref./Feedb. Value	[1684] Comm. Option STW
[1]	Bus	[734] Process PID Proportional Gain	[1672] Counter A	[593] Pulse Out 27 Bus Control	[1685] FC Port CTW 1
[2]	Logic AND	[735] Process PID Differentiation Time	[1673] Counter B	[595] Pulse Out 29 Bus Control	[1690] Alarm Word
[3]	Logic OR	[890] PCD Feed Forward	[1679] Analog output 45 [mA]	[615] Terminal 53 High Ref./Feedb. Value	[1691] Alarm Word 2
8-58	Profidrive OFF3 Select	[748] Bus Jog 1 Speed	[1684] Comm. Option STW	[625] Terminal 54 High Ref./Feedb. Value	[1692] Alarm Word 3
[0]	Digital input	[891] Bus Jog 2 Speed	[1685] FC Port CTW 1	[676] Terminal 45 Output Bus Control	[1693] Warning Word 2
[1]	Bus	[1680] Fieldbus CTW 1	[1690] Alarm Word	[696] Terminal 42 Output Bus Control	[1694] Warning Word 3
[2]	Logic AND	[1682] Fieldbus REF 1	[1691] Alarm Word 2	[733] Process PID Proportional Gain	[1695] Ext. Status Word 2
[3]	Logic OR	[3401] PCD 1 Write For Application	[1692] Alarm Word 3	[734] Process PID Integral Time	[1697] Alarm Word 3
8-7*	Protocol SW Version	[3402] PCD 2 Write For Application	[1693] Warning Word 2	[735] Process PID Differentiation Time	[3401] PCD 1 Write For Application
8-79	Protocol Firmware version	[3403] PCD 3 Write For Application	[1694] Ext. Status Word	[748] PCD Feed Forward	[3402] PCD 2 Write For Application
[0]	0 - 65535 *Size related	[3404] PCD 4 Write For Application	[1695] Ext. Status Word 2	[891] Bus Jog 1 Speed	[3403] PCD 3 Write For Application
8-8*	FC Port Diagnostics	[3405] PCD 5 Write For Application	[1697] Alarm Word 3	[1500] Operating hours	[3404] PCD 4 Write For Application
8-80	Bus Message Count	[3406] PCD 6 Write For Application	[3421] PCD 1 Read For Application	[1501] Running Hours	[3405] PCD 5 Write For Application
[0]	0 - 4294967295 *0	[3407] PCD 7 Write For Application	[3422] PCD 2 Read For Application	[1502] kWh Counter	[3406] PCD 6 Write For Application
8-81	Bus Error Count	[3408] PCD 8 Write For Application	[3423] PCD 3 Read For Application	[1600] Control Word	[3407] PCD 7 Write For Application
[0]	0 - 4294967295 *0	[3409] PCD 9 Write For Application	[3424] PCD 4 Read For Application	[1601] Reference [Unit]	[3408] PCD 8 Write For Application
8-82	Slave Messages Rcvd	[3410] PCD 10 Write For Application	[3425] PCD 5 Read For Application	[1602] Reference [%]	[3409] PCD 9 Write For Application
[0]	0 - 4294967295 *0	9-16 PCD Read Configuration	[3426] PCD 6 Read For Application	[1603] Status Word	[3410] PCD 10 Write For Application
8-83	Slave Error Count	[0] None	[3427] PCD 7 Read For Application		[3421] PCD 1 Read For Application
					[3422] PCD 2 Read For Application

[3423] PCD 3 Read For Application	9-85	Defined Parameters (6)	*[0] Disabled	[25]	Comparator 3	[16]	Thermal warning
[3424] PCD 4 Read For Application	9-90	0 - 9999 *0	[1] Enabled	[26]	Logic rule 0	[17]	Mains out of range
[3425] PCD 5 Read For Application	9-90	Changed Parameters (1)	12-82 SMTP Service	[27]	Logic rule 1	[18]	Reversing
[3426] PCD 6 Read For Application	9-91	0 - 9999 *0	*[0] Disabled	[28]	Logic rule 2	[19]	Warning
[3427] PCD 7 Read For Application	9-91	Changed Parameters (2)	[1] Enabled	[29]	Logic rule 3	[20]	Alarm (trip)
[3428] PCD 8 Read For Application	9-92	0 - 9999 *0	12-89 Transparent Socket Channel Port	[33]	Digital input DI18	[21]	Alarm (trip lock)
[3429] PCD 9 Read For Application	9-92	Changed Parameters (3)	0 - 65535 *4000	[34]	Digital input DI19	[22]	Comparator 0
[3430] PCD 10 Read For Application	9-93	Changed Parameters (4)	12-9* Advanced Ethernet Services	[35]	Digital input DI27	[23]	Comparator 1
[3450] Actual Position	9-93	Changed Parameters (4)	12-90 Cable Diagnostic	[36]	Digital input DI29	[24]	Comparator 2
[3456] Track Error	9-94	0 - 9999 *0	*[0] Disabled	[39]	Start command	[25]	Comparator 3
9-27 Parameter Edit	9-94	Changed Parameters (5)	[1] Enabled	[40]	Drive stopped	[26]	Logic rule 0
[0] Disabled		0 - 9999 *0	12-91 Auto Cross Over	[42]	Auto Reset Trip	[27]	Logic rule 1
*[1] Enabled		0 - 9999 *0	[0] Disabled	[50]	Comparator 4	[28]	Logic rule 2
9-28 Process Control			*[1] Enabled	[51]	Comparator 5	[29]	Logic rule 3
[0] Disable			12-92 IGMP Snooping	[60]	Logic rule 4	[30]	SL Time-out 0
*[1] Enable cyclic master			[0] Disabled	[61]	Logic rule 5	[31]	SL Time-out 1
9-44 Fault Message Counter			*[1] Enabled	[83]	Broken Belt	[32]	SL Time-out 2
0 - 65535 *0			12-93 Cable Error Length	13-02	Stop Event	[33]	Digital input DI18
9-52 Fault Situation Counter			0 - 65535 *0	*[40]	Drive stopped	[34]	Digital input DI19
0 - 1000 *0			12-94 Broadcast Storm Protection	13-03	Reset SLC	[35]	Digital input DI27
9-53 Profibus Warning Word			12-95 Broadcast Storm Filter	[1]	Do not reset SLC	[36]	Digital input DI29
0 - 65535 *0			*[0] Broadcast only	[1]	Reset SLC	[39]	Drive stopped
9-63 Actual Baud Rate			[1] Broadcast & Multicast	13-1* Comparators	Auto Reset Trip	[42]	Auto Reset Trip
[0] 9.6 kbit/s			12-96 Port Config	13-10	Comparator 4	[50]	Comparator 4
[1] 19.2 kbit/s			[0] Normal	*[0]	Disabled	[51]	Comparator 5
[2] 93.75 kbit/s			[1] Mirror Port 1 to 2	[1]	Reference %	[60]	Logic rule 4
[3] 187.5 kbit/s			[2] Mirror Port 2 to 1	[2]	Feedback %	[61]	Logic rule 5
[4] 500 kbit/s			[10] Port 1 disabled	[3]	Motor speed	[70]	SL Time-out 3
[6] 1500 kbit/s			[11] Port 2 disabled	[4]	Motor Current	[71]	SL Time-out 4
[7] 3000 kbit/s			[254] Mirror Int. Port to 1	[6]	Motor power	[72]	SL Time-out 5
[8] 6000 kbit/s			[255] Mirror Int. Port to 2	[7]	Motor voltage	[73]	SL Time-out 6
[9] 12000 kbit/s			12-98 Interface Counters	[8]	DC-link voltage	[74]	SL Time-out 7
[10] 31.25 kbit/s			1 - 48 *0	[12]	Analog input AI53	[83]	Broken Belt
*[255] No baudrate found			12-99 Media Counters	[13]	Analog input AI54	13-41	Logic Rule Operator 1
9-65 Profile Number			0 - 4294967295 *0	[18]	Pulse input FI29	*[0]	Disabled
0 - 0 *0			13-0* SLC Settings	[19]	Pulse input FI33	[1]	AND
9-70 Edit Set-up			13-00 SLC Controller Mode	[20]	Alarm number	[2]	OR
[1] Set-up 1			[0] Off	[30]	Counter A	[3]	AND NOT
[2] Set-up 2			[1] On	[31]	Counter B	[4]	OR NOT
*[9] Active Set-up			[13-01 Start Event	13-11	Comparator Operator	[5]	NOT AND
9-71 Profibus Save Data Values			[0] False	[0]	Less Than (<)	[6]	NOT OR
[1] Off			[1] True	[1]	Approx.Equal (~)	[7]	NOT AND NOT
9-72 Store all setups			[2] Running	[2]	Greater Than (>)	[8]	NOT OR NOT
ProfibusDriveReset			[3] In range	13-12	Comparator Value	13-42	Logic Rule Boolean 2
[0] No action			[4] On reference	13-2 Timers	0 - 9999 - 9999 *0		Same choices with 13-40
[1] Power-on reset			[7] Out of current range	13-20	SL Controller Timer	[0]	False
[2] Power-on reset prep			[8] Below l low	0 - 3600 s *0 s		13-43	Logic Rule Operator 2
[3] Comm option reset			[9] Above l high	13-4* Logic Rules			Same choices with 13-41
9-80 Defined Parameters (1)			[16] Thermal warning	13-40	Logic Rule Boolean 1	[0]	Disabled
0 - 9999 *0			[17] Mains out of range	13-40	Logic Rule Boolean 1	13-44	Logic Rule Boolean 3
9-81 Defined Parameters (2)			[18] Reversing	*[0] False			Same choices with 13-40
0 - 9999 *0			[19] Warning	[1]	True	[0]	False
9-82 Defined Parameters (3)			[20] Alarm (trip)	[2]	Running	13-5* States	SL Controller Event
0 - 9999 *0			[21] Alarm (trip lock)	[3]	In range	13-51	SL Controller Event
9-83 Defined Parameters (4)			[22] Comparator 0	[4]	On reference	[0]	False
0 - 9999 *0			[23] Comparator 1	[7]	Out of current range	[1]	True
9-84 Defined Parameters (5)			12-81 HTTP Server	[8]	Below l low	[2]	Running
0 - 9999 *0				[24]	Comparator 2	[3]	In range



[4]	On reference	[28]	Freeze output	14-15	Kin. Back-up Trip Recovery Level	[7]	On-when-Inverter-is-on-else-off Mode	-32767 - 32767 *0
[7]	Out of current range	[29]	Start timer 0	14-15	0 - 500.000 ReferenceFeedbackUnit	[8]	Variable-speed mode	15-4* Drive Identification
[8]	Below I low	[30]	Start timer 1		*Size related	14-55	Output Filter	15-40 FC Type
[9]	Above I high	[31]	Start timer 2	14-2* Reset Functions		*[0]	No Filter	15-41 Power Section
[16]	Thermal warning	[32]	Set digital out A low	14-20	Reset Mode	[1]	Sine-Wave Filter	15-42 Voltage
[17]	Mains out of range	[33]	Set digital out B low			14-6* Auto Derate	Function at Inverter Overload	0 - 20 *0
[18]	Reversing	[34]	Set digital out C low			[1]	Trip	15-43 Software Version
[19]	Warning	[35]	Set digital out D low			[1]	Derate	0 - 0 *0
[20]	Alarm (trip)	[38]	Set digital out A high			[1]	Min Switch Frequency	0 - 40 *0
[21]	Alarm (trip lock)	[39]	Set digital out B high			[2]	2.0 kHz	0 - 41 *0
[22]	Comparator 0	[40]	Set digital out C high			[3]	3.0 kHz	Actual TypeCode
[23]	Comparator 1	[41]	Set digital out D high			[4]	4.0 kHz	0 - 0 *0
[24]	Comparator 2	[60]	Reset Counter A			[5]	5.0 kHz	0 - 0 *0
[25]	Comparator 3	[61]	Reset Counter B			[6]	6.0 kHz	Drive Ordering No
[26]	Logic rule 0	[70]	Start Timer 3			[7]	8.0 kHz	0 - 0 *0
[27]	Logic rule 1	[71]	Start Timer 4			[8]	10.0 kHz	0 - 0 *0
[28]	Logic rule 2	[72]	Start Timer 5			[9]	12.0 kHz	0 - 0 *0
[29]	Logic rule 3	[73]	Start Timer 6			[10]	16.0 kHz	0 - 0 *0
[30]	SL Time-out 0	[74]	Start Timer 7			[14]	Reset at power-up	15-48 LCP Id No
[31]	SL Time-out 1	14-3* Spical Functions				[14-64]	Dead Time Compensation Zero Current Level	15-49 SW ID Control Card
[32]	SL Time-out 2	14-0* Inverter Switching					Level	15-50 SW ID Power Card
[33]	Digital input D118	14-01	Switching Frequency			*[0]	Disabled	0 - 0 *0
[34]	Digital input D119	[0]	Ran3	14-22	Operation Mode	[1]	Enabled	15-51 Drive Serial Number
[35]	Digital input D127	[1]	Ran5				Speed Derate Dead Time Compensation	0 - 0 *0
[36]	Digital input D129	[2]	2.0 kHz	14-24	Normal operation	14-65	Speed Derate Dead Time Compensation	0 - 0 *0
[39]	Start command	[3]	3.0 kHz				20 - 1000 Hz *Size related	15-6* Option Ident
[40]	Drive stopped	[4]	4.0 kHz	14-25	Trip Delay at Current Limit		Options	15-60 Option Mounted
[42]	Auto Reset Trip	[5]	5.0 kHz				Option Detection	0 - 30 *Size related
[50]	Comparator 4	[6]	6.0 kHz	14-27	Action At Inverter Fault		Protect Option Config.	Option SW Version
[51]	Comparator 5	[7]	8.0 kHz			[1]	Enable Option Change	0 - 20 *Size related
[60]	Logic rule 4	[8]	10.0 kHz	14-29	Trip		14-9* Fault Settings	Option Ordering No
[61]	Logic rule 5	[9]	12.0 kHz			[0]	Trip Level	0 - 8 *Size related
[70]	SL Time-out 3	[10]	16.0 kHz			[3]	Trip Lock	0 - 18 *Size related
[71]	SL Time-out 4	[14-3* Current Limit Ctrl.				[4]	Trip w. delayed reset	Option in Slot A
[72]	SL Time-out 5	14-30	Current Lim Ctrl, Proportional Gain			[5]	Flystart	0 - 30 *0
[73]	SL Time-out 6		0 - 500 % *100 %			15-5** Drive Information		15-70 Option in Slot A
[74]	SL Time-out 7		0 - 0x7fffff h *0 h			15-0* Operating Data		15-71 Slot A Option SW Version
[83]	Broken Belt		Current Lim Ctrl, Integration Time			15-00	Operating hours	0 - 2000 *0
13-52	SL Controller Action		0.002 - 2 s *0.020 s			15-01	Running Hours	Application Type
*[0]	Disabled		1 - 100 ms *5 ms				0 - 0x7fffff h *0 h	0 - 0x7fffff h *0
[1]	No action	14-4* Energy Optimising				15-02	kWh Counter	Drive Identification
[2]	Select set-up 1	14-40	VT Level				0 - 2147483647 kWh *0 kWh	0 - 56 *0
[3]	Select set-up 2	14-40	VT Level			15-03	Power Up's	Parameter Metadata
[10]	Select preset ref 0		40 - 90 % *66 %				0 - 2147483647 *0	0 - 9999 *0
[11]	Select preset ref 1	14-41	AEO Minimum Magnetisation			15-04	Over Temp's	16-** Data Readouts
[12]	Select preset ref 2		40 - 75 % *66 %				0 - 65535 *0	16-0* General Status
[13]	Select preset ref 3	14-44	d-axis current optimization for IPM			[0]	Do not reset	Control Word
[14]	Select preset ref 4		0 - 200 % *100 %			[1]	Reset counter	0 - 65535 *0
[15]	Select preset ref 5	14-5* Environment				*[0]	Do not reset	Reference [Unit]
[16]	Select preset ref 6	14-50	RFI Filter			[1]	Reset counter	-4999 - 4999 ReferenceFeedbackUnit *0
[17]	Select preset ref 7		Alarm				Alarm Log	Reference [%]
[18]	Select ramp 1	[1]	Kin. back-up, trip			15-30	Alarm Log: Error Code	-200 - 200 *0 %
[19]	Select ramp 2	[2]	Kin. back-up, trip w recovery				0 - 255 *0	Status Word
[22]	Run	14-51	Mains Fault Voltage Compensation			15-31	InternalFaultReason	0 - 65535 *0
[23]	Run reverse		0					
[24]	Stop	[1]	On					
[25]	Ostop	[2]	Fan Control					
[26]	DC Brake	[5]	Constant-on mode					
[27]	Coast	[6]	Constant-off mode					

16-05	Main Actual Value [%] -200 - 200 % *0 %	16-62	Analog input 53 0 - 20 *	17-11	Resolution (PPR) 10 - 10000 *1024	[1]	Enabled Ext CL1 PID Ext. CL 1 Ref./FB.	22-46	Maximum Boost Time 0 - 600 s *60 s
16-09	Custom Readout 0 - 9999 CustomReadoutUnit *0	16-63	Terminal 54 Setting Current mode [0] Voltage mode [1] Voltage mode 16-64	17-50	Resolver Interface Poles 2 - 2 *2	21-11	Ext. 1 Minimum Reference 999999999 - 999999999 ExpPID1Unit	22-47	Sleep Speed [Hz] 0 - 400.0 *0
16-10	Motor Status Power [kW] 0 - 1000 kW *0 kW	16-65	Analog output 42 [mA] 0 - 20 mA *0 mA	17-51	Input Voltage 2 - 8 V *7 V	21-12	Ext. 1 Maximum Reference 999999999 - 999999999 ExpPID1Unit	22-48	Sleep Delay Time 0 - 3600 s *0 s
16-11	Power [hp] 0 - 1000 hp *0 hp	16-66	Digital Output 0 - 15 *0	17-52	Input Frequency 2 - 15 kHz *10 kHz	21-13	Ext. 1 Reference Source *100 ExpPID1Unit	22-49	Wake-Up Delay Time 0 - 3600 s *0 s
16-12	Motor Voltage 0 - 6553.5 V *0 V	16-67	Pulse input 29 [Hz] 0 - 130000 *0	17-53	Transformation Ratio 0.1 - 1.1 *0.5	[0]	No function	22-6*	Broken Belt Detection Broken Belt Function
16-13	Frequency 0 - 6553.5 Hz *0 Hz	16-68	Pulse input 33 [Hz] 0 - 130000 *0	17-56	Encoder Sim. Resolution [0] Disabled [1] 512 [2] 1024 [3] 2048 [4] 4096	[2]	Analog Input 53	[0]	Off
16-14	Motor current 0 - 6553.5 % *0 %	16-69	Pulse output 27 [Hz] 0 - 40000 *0	17-59	Resolver Interface [0] Disabled [1] Enabled	[7]	Frequency input 29	[1]	Warning
16-15	Torque [Nm] -30000 - 30000 Nm *0 Nm	16-70	Pulse output 29 [Hz] 0 - 40000 *0	17-60	Monitoring and App. Feedback Direction [0] Clockwise [1] Counter clockwise	21-14	Ext. 1 Feedback Source No function	[2]	Trip
16-16	Speed [RPM] -30000 - 30000 RPM *0 RPM	16-71	Relay output 0 - 65535 *0	17-61	Feedback Signal Monitoring [0] Disabled [1] Warning	[8]	Frequency input 33	[2]	Broken Belt Torque
16-17	Motor Thermal 0 - 100 % *0 %	16-72	Counter A -32768 - 32767 *0	17-62	Fieldbus & FC Port Fieldbus CTW 1 0 - 65535 *0	[3]	Analog Input 53	[2]	Broken Belt Delay 0 - 600 s *10 s
16-22	Torque [%] -200 - 200 % *0 %	16-73	Counter B -32768 - 32767 *0	18-8*	Fieldbus & FC Port Fieldbus CTW 1 0 - 65535 *0	[4]	Frequency input 29	30-2*	Adv. Start Adjust High Starting Torque Time [s]
16-33	Brake Energy / 2 min 0 - 65535 V *0 V	16-79	Analog output 45 [mA] 0 - 20 mA *0 mA	18-8*	Center Winder Readout Tension PID Output -5000 - 5000 Hz *0 Hz	21-15	Ext. 1 Setpoint 999999999 - 999999999 ExpPID1Unit	30-20	High Starting Torque Current [%] 0 - 200.0 % *Size related
16-34	Heatsink Temp. -128 - 127 °C *0 °C	16-82	Fieldbus REF 1 -32768 - 32767 *0	18-8*	Center Winder Output -5000 - 5000 Hz *0 Hz	21-17	Ext. 1 Reference [Unit] 999999999 - 999999999 ExpPID1Unit	30-22	Locked Rotor Protection [0] Off [1] On
16-35	Inverter Thermal 0 - 255 % *0 %	16-84	Comm. Option STW 0 - 65535 *0	18-8*	Line Speed -5000 - 5000 Hz *0 Hz	21-18	Ext. 1 Feedback [Unit] 999999999 - 999999999 ExpPID1Unit	30-23	Locked Rotor Detection Time [s] 0.05 - 1 s *0.10 s
16-36	Inv. Nom. Current 0 - 6553.5 A *0 A	16-85	FC Port CTW 1 -32768 - 32767 *0	18-8*	Diameter 0 - 100 % *0 %	21-19	Ext. 1 Output [%] 0 - 100 % *0 %	32-1*	Motion Control Basic Settings User Unit
16-37	Inv. Max. Current 0 - 6553.5 A *0 A	16-86	FC Port REF 1 -32768 - 32767 *0	18-8*	Tapered Tension Set Point 0 - 100 % *0 %	21-20	Ext. 1 Normal/inverse Control Normal	32-11	User Unit Denominator 1 - 65535 *1
16-38	SL Controller State 0 - 20 *0	16-87	Alarm Word 0 - 0xFFFFFFFFUL *0	18-8*	Tension PID Output -5000 - 5000 Hz *0 Hz	21-21	Ext. 1 Proportional Gain 0 - 10 *0.01	32-5*	Feedback Source
16-39	Control Card Temp. 0 - 65535 °C *0 °C	16-88	Warning Word 0 - 0xFFFFFFFFUL *0	18-8*	Diagnosis Readouts Alarm Word 2 0 - 0xFFFFFFFFUL *0	21-22	Ext. 1 Integral Time 0.01 - 10000 s *10000 s	32-50	Source Slave
16-5*	Ref. & Feeds.	16-89	Warning Word 0 - 0xFFFFFFFFUL *0	18-8*	PID Readouts Process PID Error -200 - 200 % *0 %	21-23	Ext. 1 Differentiation Time 0 - 10 s *0 s	[0]	MCB102
16-50	External Reference -200 - 200 % *0 %	16-92	Warning Word 0 - 0xFFFFFFFFUL *0	18-8*	Process PID Output -200 - 200 % *0 %	21-24	Ext. 1 Diff. Gain Limit 1 - 50 *5	[2]	MCB103
16-52	Feedback[Unit] -4999 - 4999 ProcessCtrlUnit *0	16-93	Warning Word 0 - 0xFFFFFFFFUL *0	18-8*	Process PID Clamped Output -200 - 200 % *0 %	22-*	App. Functions	[3]	VM
16-53	Digi. Pot Reference -200 - 200 *0	16-94	Ext. Status Word 0 - 0xFFFFFFFFUL *0	18-8*	Process PID Gain Scaled Output -200 - 200 % *0 %	22-0*	Miscellaneous	32-6*	PID
16-57	Feedback [RPM] -30000 - 30000 RPM *0 RPM	16-95	Ext. Status Word 0 - 0xFFFFFFFFUL *0	18-8*	Ext. Closed Loop Ext. CL Autotuning	22-0*	Sleepmode CL Control Mode	32-60	Proportional factor 0.000 - 1000.000 *1.000
16-60	Digital Input 0 - 65535 *0	16-96	Signal Type [0] None *[1] RS422 (5V TTL) [2] Sinusoidal 1Vpp	17-10	Signal Type [0] None *[1] RS422 (5V TTL) [2] Sinusoidal 1Vpp	22-2*	Simplified Sleep Mode	32-61	Derivative factor 0.000 - 1000.000 *0.000
16-61	Terminal 53 Setting Current mode [0] Current mode [1] Voltage mode	17-10	Signal Type [0] None *[1] RS422 (5V TTL) [2] Sinusoidal 1Vpp	17-10	Signal Type [0] None *[1] RS422 (5V TTL) [2] Sinusoidal 1Vpp	22-40	Minimum Run Time 0 - 600 s *10 s	32-62	Integral factor 0.0000 - 100.0000 *0.0000



32-67	Max. Tolerated Position Error	-2147483647 - 2147483647 *0	[7]	Brake Wear Limit	[7]	*[0]	Load cell
32-68	Reverse Behavior For Slave	34-60 Synchronizing Status	[8]	Quick Stop	[8]	[1]	Dancer
[1]	Reversing allowed	0 - 4294967295 *0	[9]	PID Error Too Big	[9]	[0]	Center Winder Cmd Src
[2]	Reversing blocked	37-0* Application Settings	[12]	Rev. Operation	[12]	*[1]	Digital and parameter functions
32-69	PID Sample Time	37-0* Application Settings	[20]	Fwd. Operation	[20]	[1]	Parameter 3754~3759 control the functions
32-71	Size of the Control Window (Activation)	37-00 Application Mode	37-19	Can not find home position	37-19	[2]	Digital Input control
		[1] Drive mode		Pos. New Index	37-19	[3]	Diameter Change Rate
		[2] Center winder		0 - 255 *0	37-41	[3]	0.001 - 0.05 % *0.001 %
		[3] Position Control		37-2* Center Winder	37-42	[4]	Tapered Tension Change Rate
		37-1* Position Control		0 - 110 % *0.1 %	37-43	[5]	Diameter Calculator Min Speed
32-72	Size of the Control Window (Deactiv)	37-01 Pos. Feedback Source	[1]	Unwind	37-44	[6]	Line Acceleration Feed Forward
		[1] 24V Encoder		Tension Set Point	37-45	[7]	Line Speed Source
		[2] MCB102		0 - 100 % *0 %	*[0]	[8]	No function
		[3] MCB103		Taper Set Point	[1]	[1]	24V encoder
		37-02 Pos. Target		-110 - 110 % *0 %	[2]	[2]	MCB102
		37-03 Pos. Type		Partial Roll Diameter Value	[3]	[3]	MCB103
		[1] Absolute		5 - 100 % *5 %	[4]	[4]	Analog input 53
		[2] Relative		Core1 Diameter	[5]	[5]	Analog input 54
		37-04 Pos. Velocity		5 - 100 % *5 %	[6]	[6]	Frequency input 29
		1 - 30000 RPM *100 RPM		Core2 Diameter	[7]	[7]	Frequency input 33
		37-05 Pos. Ramp Up Time		5 - 100 % *5 %	37-46	[8]	Winder Speed Match Scale
		50 - 100000 ms *5000 ms		Winder Jog Speed	37-47	[9]	Tension PID Profile
		37-06 Pos. Ramp Down Time		0 - 100 % *0 %	37-48	[10]	Tension PID Proportional Gain
		50 - 100000 ms *5000 ms		TLD Low Limit	37-49	[11]	Tension PID Derivate Time
		37-07 Pos. Auto Brake Ctrl		0 - 100 % *0 %	37-50	[12]	Tension PID Integral Time
		[0] Disable		TLD High Limit	37-51	[13]	Tension PID Out Limit
		[1] Enable		TLD Timer	37-52	[14]	0 - 100 % *0 %
		37-08 Pos. Hold Delay		0.001 - 5 *0.001 s	37-53	[15]	Tension PID Der Gain Limit
		0 - 10000 ms *0 ms		TLD On Delay	[16]	[16]	Disabled
		37-09 Pos. Coast Delay		Disabled	37-54	[17]	Winder Jog Reverse
		0 - 1000 ms *200 ms		Enabled	[18]	[18]	Jog reverse
		37-10 Pos. Brake Delay		Diameter Limit Detector	37-55	[19]	Winder Jog Forward
		0 - 1000 ms *200 ms		0 - 100 % *100 %	[20]	[20]	Jog forward
		37-11 Pos. Brake Wear Limit		Initial Diameter Measurement	37-56	[21]	New Diameter Select
		0 - 1073741824 *0		[0] Set diameter when diameter reset	[22]	[22]	Core diameter
		37-12 Pos. PID Anti Windup		[1] Set diameter based on analog signal	[23]	[23]	Partial roll diameter
		[0] Disable		Diameter Measurement Input	37-57	[24]	Tension On/Off
		[1] Enable		[0] No Function	[25]	[25]	Off
		37-13 Pos. PID Output Clamp		[1] Input53(0~10 VDC or 0~20 mA)	[26]	[26]	On
		0 - 10000 *1000		[2] Input54(0~10 VDC or 0~20 mA)	[27]	[27]	Core Select
		37-14 Pos. Ctrl. Source		Reading at Core	[28]	[28]	Core1 diameter
		[0] Di		0 - 10 *0	[29]	[29]	Core2 diameter
		[1] FieldBus		Reading at Full Roll	[30]	[30]	Diameter Reset
		37-15 Pos. Direction Block		0 - 20 V *0 V	[31]	[31]	Off
		[0] No Blocking		Tension Set Point Input	[32]	[32]	On
		[1] Block Reverse		Par3721	[33]	[33]	Core Select
		37-17 Pos. Ctrl Fault Behaviour		Tension Set Point Input	[34]	[34]	Core1 diameter
		[0] Ramp Down&Brake		[1] Input53(0~10 VDC or 0~20 mA)	[35]	[35]	Core2 diameter
		[1] Brake Directly		[2] Input54(0~10 VDC or 0~20 mA)	[36]	[36]	Diameter Reset
		37-18 Pos. Ctrl Fault Reason		[0] Par3722	[37]	[37]	Off
		[0] No Fault		[1] Input53(0~10 VDC or 0~20 mA)	[38]	[38]	On
		[1] Homing Needed		[2] Input54(0~10 VDC or 0~20 mA)	[39]	[39]	Core Select
		[2] Pos. HW Limit		Tension Feedback Input	[40]	[40]	Core1 diameter
		[3] Neg. HW Limit		[0] No Function	[41]	[41]	Core2 diameter
		[4] Pos. SW Limit		Input53(0~10 VDC or 0~20 mA)	[42]	[42]	Diameter Reset
		[5] Neg. SW Limit		Input54(0~10 VDC or 0~20 mA)	[43]	[43]	Off
				Tension Feedback Type	[44]	[44]	On

Index

A

Abbreviation.....	62
AC input.....	4
AC mains.....	4
AC waveform.....	3, 4
Alarm log.....	27
AMA with T27 connected.....	43
Ambient condition.....	59
Analog output.....	57
Application example.....	42
Approval and certification.....	3
Auto on.....	28, 33
Automatic motor adaptation.....	31

B

Branch circuit protection.....	60
--------------------------------	----

C

Cable length.....	56
Clearance requirement.....	11
Control	
Characteristic.....	58
cable.....	19
system.....	3
terminal.....	28, 48
wiring.....	13
Control card	
+10 V DC output.....	58
Performance.....	59
RS485 serial communication.....	57
Convention.....	62
Cross-section.....	56

D

DC current.....	4
Default setting.....	29
Derating.....	11, 59
Digital output.....	58
Discharge time.....	8
Disconnect switch.....	21

E

Electrical noise.....	14
EMC.....	59
EMC-compliant installation.....	13
Encoder rotation.....	32

Energy efficiency.....	53, 54, 55
Energy efficiency class.....	59
External command.....	4
External controller.....	3

F

Fault	
log.....	27
Floating delta.....	17
Fuse.....	13, 60

G

Ground connection.....	13
Ground loop.....	19
Ground wire.....	13
Grounded delta.....	17
Grounding.....	13, 17, 21

H

Hand on.....	28
High altitude.....	9
High voltage.....	8, 21
Horizontal mounting.....	12

I

IEC 61800-3.....	17, 59
Induced voltage.....	13
Initialization	
Manual procedure.....	30
Procedure.....	29
Input	
Power.....	13
signal.....	19
voltage.....	21
Power.....	4, 21
Terminal.....	21

Inputs

Analog inputs.....	57
Digital inputs.....	20, 56
Pulse inputs.....	57

Installation.....	11
Installation environment.....	11
Isolated mains.....	17

L

Leakage current.....	9
Load sharing.....	8
Local control.....	28

M

Main menu..... 25, 27

Mains
 supply (L1, L2, L3)..... 56
 supply data..... 53
 Voltage..... 27

Menu key..... 22, 27

Menu structure..... 28

Motor
 Current..... 4
 cable..... 13, 17
 current..... 27, 32
 data..... 30, 32
 output..... 56
 power..... 13, 27
 protection..... 59
 status..... 3
 wiring..... 13, 17
 Rotation..... 32

Multiple frequency converters..... 17

N

Navigation key..... 22, 27, 28

Noise isolation..... 13

Numeric display..... 22

O

Open loop..... 58

Operation key..... 22, 27

Optional equipment..... 3, 17, 21

Output current..... 58

Overcurrent protection..... 13

P

PELV..... 9, 45, 58

Power connection..... 13

Power factor..... 4, 17

PROFIBUS..... 33

Programming..... 20, 27, 29

Protection and feature..... 59

Q

Qualified personnel..... 8

Quick menu..... 23, 27

R

Reference..... 27

Relay output..... 58

Remote command..... 3

Reset..... 27, 28, 30, 46, 59

RFI filter..... 17

Run command..... 33

S

Safety..... 9

Serial communication..... 3, 19, 20, 28, 46

Set-up..... 33

Shielded cable..... 13

Shielded control cable..... 19

Shock..... 11

Side-by-side installation..... 11

Specification..... 11, 20, 53

Speed reference..... 33, 43

Start-up..... 29

Status menu..... 25

Supply voltage..... 21, 57

Symbol..... 62

System feedback..... 3

T

Technical data..... 56

Terminal programming..... 19

Terminal tightening torque..... 61

Terminals
 Control terminal..... 28
 Output terminal..... 21

Thermistor..... 45

Torque
 characteristic..... 56

Transient protection..... 4

Troubleshooting..... 46

U

Unintended start..... 8

V

Vibration..... 11

Voltage level..... 56

W

Warning and alarm list..... 48

Wire size..... 13



.....
Danfoss can accept no responsibility for possible errors in catalogues, brochures and other printed material. Danfoss reserves the right to alter its products without notice. This also applies to products already on order provided that such alterations can be made without subsequential changes being necessary in specifications already agreed. All trademarks in this material are property of the respective companies. Danfoss and the Danfoss logotype are trademarks of Danfoss A/S. All rights reserved.
.....

Danfoss A/S
Ulsnaes 1
DK-6300 Graasten
vlt-drives.danfoss.com

