

Contents

<b>1 Introduction</b>	<b>4</b>
1.1 How to Read This Design Guide	4
1.1.1 Symbols	4
1.1.2 Abbreviations	4
1.1.3 Definitions	5
1.2 Safety Precautions	7
1.4.1 Software Version	8
<b>2 Product Overview</b>	<b>11</b>
2.1 Enclosure Type Overview	11
2.2 Electrical Installation	12
2.3.1 Control Principle	13
2.3.2 FC 360 Controls	13
2.3.3 Control Structure in VVC <sup>plus</sup>	14
2.3.4 Internal Current Control in VVC <sup>plus</sup> Mode	15
2.3.5 Local (Hand On) and Remote (Auto On) Control	15
2.4 Reference Handling	16
2.4.1 Reference Limits	17
2.4.2 Scaling of Preset References and Bus References	18
2.4.3 Scaling of Analog and Pulse References and Feedback	18
2.4.4 Dead Band Around Zero	20
2.5 PID Control	24
2.5.1 Speed PID Control	24
2.5.2 Process PID Control	27
2.5.3 Example of Process PID Control	29
2.5.4 Ziegler Nichols Tuning Method	31
2.6 General Aspects of EMC	32
2.6.1 General Aspects of EMC Emissions	32
2.6.2 EMC Test Results	33
2.6.3 Immunity Requirements	34
2.7.1 PELV - Protective Extra Low Voltage	35
2.9 Brake Functions	36
2.9.1 Mechanical Holding Brake	36
2.9.2 Dynamic Braking	36
2.9.3 Selection of Brake Resistor	36
2.10 Smart Logic Controller	38
2.11 Extreme Running Conditions	39
2.11.1 Motor Thermal Protection	40

<b>3 RS-485 Installation and Set-up</b>	<b>41</b>
3.1.1 Overview	41
3.2 FC Protocol Overview	42
3.3 Network Configuration	43
3.4 FC Protocol Message Framing Structure	43
3.4.1 Content of a Character (byte)	43
3.4.2 Telegram Structure	43
3.4.3 Telegram Length (LGE)	43
3.4.6 The Data Field	43
3.4.13 Process Words (PCD)	46
3.5 Examples	46
3.6 Modbus RTU Overview	46
3.6.1 Assumptions	46
3.6.2 What the User Should Already Know	47
3.6.3 Modbus RTU Overview	47
3.6.4 Frequency Converter with Modbus RTU	47
3.8 Modbus RTU Message Framing Structure	47
3.8.1 Frequency Converter with Modbus RTU	47
3.8.2 Modbus RTU Message Structure	48
3.8.3 Start/Stop Field	48
3.8.4 Address Field	48
3.8.5 Function Field	48
3.8.6 Data Field	48
3.8.7 CRC Check Field	48
3.8.9 How to Control the Frequency Converter	50
3.8.10 Function Codes Supported by Modbus RTU	50
3.8.11 Modbus Exception Codes	51
3.9 How to Access Parameters	51
3.9.1 Parameter Handling	51
3.9.2 Storage of Data	51
3.9.3 IND	51
3.9.4 Text Blocks	51
3.9.5 Conversion Factor	51
3.9.6 Parameter Values	51
3.10 Examples	51
3.10.2 Force/Write Single Coil (05 HEX)	52
3.10.3 Force/Write Multiple Coils (0F HEX)	52
3.10.5 Preset Single Register (06 HEX)	53
3.11 Danfoss FC Control Profile	54
3.11.1 Control Word According to FC Profile (8-10 Protocol = FC profile)	54

<b>4 Application Examples</b>	<b>58</b>
4.1.1 Encoder Connection	61
4.1.2 Encoder Direction	61
4.1.3 Closed Loop Drive System	61
<b>5 Type Code and Selection</b>	<b>62</b>
5.1.1 Drive Configurator	63
5.2 Options and Accessories	63
5.3 Brake Resistors	63
5.3.1 Ordering Numbers: Brake Resistors 10%	64
5.3.2 Ordering Numbers: Brake Resistors 40%	65
5.4 Sine-wave Filters	65
<b>6 Specifications</b>	<b>66</b>
6.1 Power-dependent Specifications	66
6.1.1 Mains Supply 3 x 380-480 V AC	66
6.2 General Specifications	69
6.3 Efficiency	73
6.4 Acoustic Noise	73
6.5 dU/dt Conditions	73
6.6 Special Conditions	74
6.6.1 Manual Derating	74
6.6.2 Automatic Derating	75
<b>Index</b>	<b>76</b>

# 1 Introduction

## 1.1 How to Read This Design Guide

This Design Guide will introduce all aspects of the frequency converter.

### Available literature

- The VLT® AutomationDrive FC 360 Quick Guide provides the necessary information for getting the drive up and running.
- The VLT® AutomationDrive FC 360 Design Guide entails all technical information about the drive and customer design and applications.
- The VLT® AutomationDrive FC 360 Programming Guide provides information on how to programme and includes complete parameter descriptions.

Danfoss Drives technical literature is also available online at [www.danfoss.com/BusinessAreas/DrivesSolutions/Documentations/Technical+Documentation](http://www.danfoss.com/BusinessAreas/DrivesSolutions/Documentations/Technical+Documentation).

### 1.1.1 Symbols

The following symbols are used in this manual.

#### **⚠ WARNING**

Indicates a potentially hazardous situation which, if not avoided, could result in death or serious injury.

#### **⚠ CAUTION**

Indicates a potentially hazardous situation which, if not avoided, may result in minor or moderate injury. It may also be used to alert against unsafe practices.

#### **CAUTION**

Indicates a situation that may result in equipment or property-damage-only accidents.

#### **NOTE**

Indicates highlighted information that should be regarded with attention to avoid mistakes or operate equipment at less than optimal performance.

\* Indicates default setting

## 1.1.2 Abbreviations

Alternating current	AC
American wire gauge	AWG
Ampere/AMP	A
Automatic Motor Adaptation	AMA
Current limit	$I_{LIM}$
Degrees Celsius	°C
Direct current	DC
Drive Dependent	D-TYPE
Electro Magnetic Compatibility	EMC
Electronic Thermal Relay	ETR
Gram	g
Hertz	Hz
Horsepower	hp
Kilohertz	kHz
Local Control Panel	LCP
Meter	m
Millihenry Inductance	mH
Milliamper	mA
Millisecond	ms
Minute	min
Motion Control Tool	MCT
Nanofarad	nF
Newton Meters	Nm
Nominal motor current	$I_{M,N}$
Nominal motor frequency	$f_{M,N}$
Nominal motor power	$P_{M,N}$
Nominal motor voltage	$U_{M,N}$
Parameter	par.
Permanent Magnet motor	PM motor
Protective Extra Low Voltage	PELV
Printed Circuit Board	PCB
Rated Inverter Output Current	$I_{INV}$
Revolutions Per Minute	RPM
Regenerative terminals	Regen
Second	sec.
Synchronous Motor Speed	$n_s$
Torque limit	$T_{LIM}$
Volts	V
The maximum output current	$I_{VLT,MAX}$
The rated output current supplied by the frequency converter	$I_{VLT,N}$

Table 1.1 Abbreviations

### 1.1.3 Definitions

#### Frequency converter

##### Coast

The motor shaft is in free mode. No torque on motor.

##### $I_{MAX}$

The maximum output current.

##### $I_N$

The rated output current supplied by the frequency converter.

##### $U_{MAX}$

The maximum output voltage.

#### Input

##### Control command

Start and stop the connected motor by means of LCP and the digital inputs.

Functions are divided into two groups.

Functions in group 1 have higher priority than functions in group 2.

Group 1	Reset, Coasting stop, Reset and Coasting stop, Quick-stop, DC braking, Stop and the "Off" key.
Group 2	Start, Pulse start, Reversing, Start reversing, Jog and Freeze output

Table 1.2 Control Command Functions

#### Motor

##### $f_{JOG}$

The motor frequency when the jog function is activated (via digital terminals).

##### $f_M$

Motor frequency. Output from the frequency converter. Output frequency is related to the shaft speed on motor depending on number of poles and slip frequency.

##### $f_{MAX}$

The maximum output frequency the frequency converter applies on its output. The maximum output frequency is set in limit 4-12 Motor Speed Low Limit [Hz], 4-14 Motor Speed High Limit [Hz] and 4-19 Max Output Frequency.

##### $f_{MIN}$

The minimum motor frequency from frequency converter. Default 0 Hz.

##### $f_{M,N}$

The rated motor frequency (nameplate data).

##### $I_M$

The motor current.

##### $I_{M,N}$

The rated motor current (nameplate data).

##### $n_{M,N}$

The rated motor speed (nameplate data).

##### $n_s$

Synchronous motor speed

$$n_s = \frac{2 \times par. 1 - 23 \times 60 \text{ s}}{par. 1 - 39}$$

##### $P_{M,N}$

The rated motor power (nameplate data).

##### $T_{M,N}$

The rated torque (motor).

##### $U_M$

The instantaneous motor voltage.

##### $U_{M,N}$

The rated motor voltage (nameplate data).

#### Break-away torque

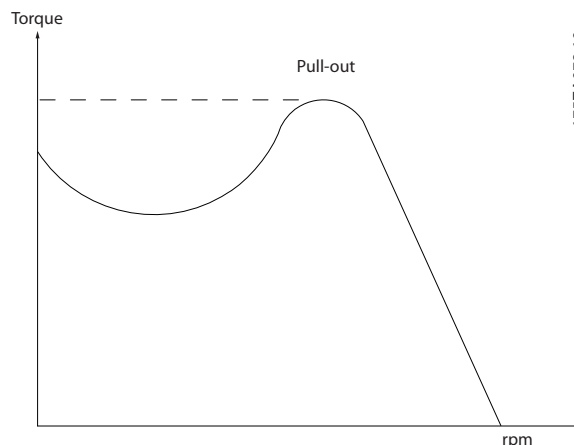

Illustration 1.1 Break-away Torque

##### $\eta$

The efficiency of the frequency converter is defined as the ratio between the power output and the power input.

#### Start-disable command

A stop command belonging to the group 1 control commands - see this group.

#### Stop command

See Control commands.

#### References

##### Analog Reference

An analog signal applied to input 53 or 54. Signal voltage is 0-10 V and current 0-20 mA or 4-20 mA.

##### Binary Reference

A signal applied to the serial communication port (RS-485 term 68 to 69).

Preset Reference

A defined preset reference to be set from -100% to +100% of the reference range. Selection of eight preset references via the digital terminals.

Pulse Reference

A pulse reference applied to term 29 or 33, selected by *5-13 Terminal 29 Digital Input* or *5-15 Terminal 33 Digital Input [32] Pulse time based*. Scaling in parameter group 5-5\* *Pulse Input*.

Ref<sub>MAX</sub>

Determines the relationship between the reference input at 100% full scale value (typically 10 V, 20 mA) and the resulting reference. The maximum reference value set in *3-03 Maximum Reference*.

Ref<sub>MIN</sub>

Determines the relationship between the reference input at 0% value (typically 0 V, 0 mA, 4 mA) and the resulting reference. The minimum reference value set in *3-02 Minimum Reference*.

**Miscellaneous**Analog Inputs

The analog inputs are used for controlling various functions of the frequency converter.

There are two types of analog inputs:

Current input, 0-20 mA and 4-20 mA

Voltage input, 0-10 V DC.

Analog Outputs

The analog outputs can supply a signal of 0-20 mA, 4-20 mA.

Automatic Motor Adaptation, AMA

AMA algorithm determines the electrical parameters for the connected motor at standstill.

Brake Resistor

The brake resistor is a module capable of absorbing the brake power generated in regenerative braking. This regenerative braking power increases the intermediate circuit voltage and a brake chopper ensures that the power is transmitted to the brake resistor.

CT Characteristics

Constant torque characteristics used for all applications such as conveyor belts, displacement pumps and cranes.

Digital Inputs

The digital inputs can be used for controlling various functions of the frequency converter.

Digital Outputs

The frequency converter features two Solid State outputs that can supply a 24 V DC (max. 40 mA) signal.

ETR

Electronic Thermal Relay is a thermal load calculation based on present load and time. Its purpose is to estimate the motor temperature.

Hiperface®

Hiperface® is a registered trademark by Stegmann.

Initialising

If initialising is carried out (*14-22 Operation Mode*), the frequency converter returns to the default setting.

Intermittent Duty Cycle

An intermittent duty rating refers to a sequence of duty cycles. Each cycle consists of an on-load and an off-load period. The operation can be either periodic duty or non-periodic duty.

LCP

The Local Control Panel makes up a complete interface for control and programming of the frequency converter. The control panel is detachable and can be installed up to 3 metres from the frequency converter, i.e. in a front panel by means of the installation kit option.

NLCP

Numerical Local Control Panel interface for control and programming of frequency converter. The display is numerical and the panel is used to display process values. The NLCP has storing and copy function.

lsb

Least significant bit.

msb

Most significant bit.

MCM

Short for Mille Circular Mil, an American measuring unit for cable cross-section. 1 MCM = 0.5067 mm<sup>2</sup>.

On-line/Off-line Parameters

Changes to on-line parameters are activated immediately after the data value is changed. Changes to off-line parameters are not activated until you enter [OK] on the LCP.

Process PID

The PID regulator maintains the desired speed, pressure, temperature, etc. by adjusting the output frequency to match the varying load.

PCD

Process Data

Pulse Input/Incremental Encoder

An external digital sensor used for feedback information of motor speed and direction. Encoders are used for high speed accuracy feedback and in high dynamic applications. The encoder connection is either via term 32 and 32 or encoder option MCB 102.

RCD

Residual Current Device.

Set-up

You can save parameter settings in 2 set-ups. Toggle between the two parameter set-ups and edit one set-up, while another set-up is active.

SFAVM

Switching pattern called Stator Flux oriented Asynchronous Vector Modulation.

### Slip Compensation

The frequency converter compensates for the motor slip by giving the frequency a supplement that follows the measured motor load keeping the motor speed almost constant.

### Smart Logic Control (SLC)

The SLC is a sequence of user defined actions executed when the associated user defined events are evaluated as true by the Smart Logic Controller. (Parameter group 13-\*\* *Smart Logic*).

### STW

Status Word

### FC Standard Bus

Includes RS-485 bus with FC protocol or MC protocol. See 8-30 *Protocol*.

### Thermistor:

A temperature-dependent resistor placed where the temperature is to be monitored (frequency converter or motor).

### THD

Total Harmonic Distortion state the total contribution of harmonic.

### Trip

A state entered in fault situations, e.g. if the frequency converter is subject to an over-temperature or when the frequency converter is protecting the motor, process or mechanism. Restart is prevented until the cause of the fault has disappeared and the trip state is cancelled by activating reset or, in some cases, by being programmed to reset automatically. Trip may not be used for personal safety.

### Trip Locked

A state entered in fault situations when the frequency converter is protecting itself and requiring physical intervention, e.g. if the frequency converter is subject to a short circuit on the output. A locked trip can only be cancelled by cutting off mains, removing the cause of the fault, and reconnecting the frequency converter. Restart is prevented until the trip state is cancelled by activating reset or, in some cases, by being programmed to reset automatically. Trip may not be used for personal safety.

### VT Characteristics

Variable torque characteristics used for pumps and fans.

### VVC<sup>plus</sup>

If compared with standard voltage/frequency ratio control, Voltage Vector Control (VVC<sup>plus</sup>) improves the dynamics and the stability, both when the speed reference is changed and in relation to the load torque.

### 60° AVM

Switching pattern called 60° Aynchronous Vector Modulation.

### Power Factor

The power factor is the relation between  $I_1$  and  $I_{RMS}$ .

$$\text{Power factor} = \frac{\sqrt{3} \times U \times I_1 \cos\varphi}{\sqrt{3} \times U \times I_{RMS}}$$

The power factor for 3-phase control:

$$= \frac{I_1 \times \cos\varphi}{I_{RMS}} = \frac{I_1}{I_{RMS}} \text{ since } \cos\varphi = 1$$

The power factor indicates to which extent the frequency converter imposes a load on the mains supply.

The lower the power factor, the higher the  $I_{RMS}$  for the same kW performance.

$$I_{RMS} = \sqrt{I_1^2 + I_5^2 + I_7^2 + \dots + I_n^2}$$

In addition, a high power factor indicates that the different harmonic currents are low.

The complete power range of FC 360 frequency converters have built-in DC coils in the DC link to have a high power factor and to reduce the THD on the main supply.

## 1.2 Safety Precautions

### **⚠ WARNING**

**The voltage of the frequency converter is dangerous whenever connected to mains. Incorrect installation of the motor, frequency converter or fieldbus may cause death, serious personal injury or damage to the equipment. Consequently, the instructions in this manual, as well as national and local rules and safety regulations, must be complied with.**

#### Safety Regulations

1. The mains supply to the frequency converter must be disconnected whenever repair work is to be carried out. Check that the mains supply has been disconnected and that the necessary time has elapsed before removing motor and mains supply.
2. [Off/Reset] on the control panel of the frequency converter does not disconnect the mains supply and consequently it must not be used as a safety switch.
3. The equipment must be properly earthed, the user must be protected against supply voltage and the motor must be protected against overload in accordance with applicable national and local regulations.
4. The earth leakage current exceeds 3.5 mA.
5. Protection against motor overload is not included in the factory setting. If this function is desired, set 1-90 *Motor Thermal Protection* to data value [4] *ETR trip 1* or data value [3] *ETR warning 1*.

- The frequency converter has more voltage sources than L1, L2 and L3, when load sharing (linking of DC intermediate circuit). Check that all voltage sources have been disconnected and that the necessary time has elapsed before commencing repair work.

**Warning against unintended start**

- The motor can be brought to a stop by means of digital commands, bus commands, references or a local stop, while the frequency converter is connected to mains. If personal safety considerations (e.g. risk of personal injury caused by contact with moving machine parts following an unintentional start) make it necessary to ensure that no unintended start occurs, these stop functions are not sufficient. In such cases the mains supply must be disconnected.
- The motor may start while setting the parameters. If this means that personal safety may be compromised (e.g. personal injury caused by contact with moving machine parts), motor starting must be prevented, for instance by secure disconnection of the motor connection.
- A motor that has been stopped with the mains supply connected, may start if faults occur in the electronics of the frequency converter, through temporary overload or if a fault in the power supply grid or motor connection is remedied. If unintended start must be prevented for personal safety reasons (e.g. risk of injury caused by contact with moving machine parts), the normal stop functions of the frequency converter are not sufficient. In such cases the mains supply must be disconnected.
- Control signals from, or internally within, the frequency converter may in rare cases be activated in error, be delayed or fail to occur entirely. When used in situations where safety is critical, e.g. when controlling the electromagnetic brake function of a hoist application, these control signals must not be relied on exclusively.

**⚠ WARNING**

**High Voltage**

Touching the electrical parts may be fatal - even after the equipment has been disconnected from mains. Make sure that all voltage inputs have been disconnected, including load sharing (linkage of DC intermediate circuit), as well as motor connection for kinetic back up. Systems where frequency converters are installed must, if necessary, be equipped with additional monitoring and protective devices according to the valid safety regulations, e.g. law on mechanical tools, regulations for the prevention of accidents etc. Modifications on the frequency converters by means of the operating software are allowed.

**NOTE**

Hazardous situations shall be identified by the machine builder/ integrator who is responsible for taking necessary preventive means into consideration. Additional monitoring and protective devices may be included, always according to valid national safety regulations, e.g. law on mechanical tools, regulations for the prevention of accidents.

**⚠ WARNING**

The DC link capacitors remain charged after power has been disconnected. Be aware that there may be high voltage on the DC link. To avoid electrical shock hazard, disconnect the frequency converter from mains before carrying out maintenance. When using a PM-motor, make sure it is disconnected. Before doing service on the frequency converter wait at least the amount of time indicated below:

Voltage [V]	Minimum waiting time [minutes]	
	4	15
380-480	0.37-7.5 kW	11-75 kW

Table 1.3 Discharge Time

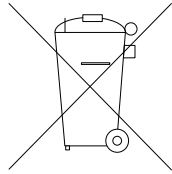

1.3.1 Disposal Instruction



Equipment containing electrical components may not be disposed of together with domestic waste. It must be separately collected with electrical and electronic waste according to local and currently valid legislation.

1.4.1 Software Version

**Design Guide**  
Software version: 1.0x

This Design Guide can be used for all FC 360 frequency converters with software version 1.0x. The software version number can be seen from 15-43 Software Version.



## 1.5.1 CE Conformity and Labelling

### The machinery directive (2006/42/EC)

Frequency converters do not fall under the machinery directive. However, if a frequency converter is supplied for use in a machine, we provide information on safety aspects relating to the frequency converter.

### What is CE Conformity and Labelling?

The purpose of CE labelling is to avoid technical trade obstacles within EFTA and the EU. The EU has introduced the CE label as a simple way of showing whether a product complies with the relevant EU directives. The CE label says nothing about the specifications or quality of the product. Frequency converters are regulated by two EU directives:

### The low-voltage directive (2006/95/EC)

Frequency converters must be CE labelled in accordance with the low-voltage directive of January 1, 1997. The directive applies to all electrical equipment and appliances used in the 50-1000 V AC and the 75-1500 V DC voltage ranges. Danfoss CE-labels in accordance with the directive and issues a declaration of conformity upon request.

### The EMC directive (2004/108/EC)

EMC is short for electromagnetic compatibility. The presence of electromagnetic compatibility means that the mutual interference between different components/appliances does not affect the way the appliances work. The EMC directive came into effect January 1, 1996. Danfoss CE-labels in accordance with the directive and issues a declaration of conformity upon request. To carry out EMC-correct installation, see the instructions in this Design Guide. In addition, we specify which standards our products comply with. We offer the filters presented in the specifications and provide other types of assistance to ensure the optimum EMC result.

The frequency converter is most often used by professionals of the trade as a complex component forming part of a larger appliance, system or installation. It must be noted that the responsibility for the final EMC properties of the appliance, system or installation rests with the installer.

## 1.5.2 What Is Covered

The EU "Guidelines on the Application of Council Directive 2004/108/EC" outline three typical situations of using a frequency converter. See the following for EMC coverage and CE labelling.

1. The frequency converter is sold directly to the end-consumer. The frequency converter is for example sold to a DIY market. The end-consumer is a layman. He installs the frequency converter himself for use with a hobby machine, a kitchen appliance, etc. For such applications, the

frequency converter must be CE labelled in accordance with the EMC directive.

2. The frequency converter is sold for installation in a plant. The plant is built up by professionals of the trade. It could be a production plant or a heating/ventilation plant designed and installed by professionals of the trade. Neither the frequency converter nor the finished plant has to be CE labelled under the EMC directive. However, the unit must comply with the basic EMC requirements of the directive. This is ensured by using components, appliances, and systems that are CE labelled under the EMC directive.
3. The frequency converter is sold as part of a complete system. The system is being marketed as complete and could e.g. be an air-conditioning system. The complete system must be CE labelled in accordance with the EMC directive. The manufacturer can ensure CE labelling under the EMC directive either by using CE labelled components or by testing the EMC of the system. If he chooses to use only CE labelled components, he does not have to test the entire system.

## 1.5.3 Danfoss Frequency Converter and CE Labelling

CE labelling is a positive feature when used for its original purpose, i.e. to facilitate trade within the EU and EFTA.

However, CE labelling may cover many different specifications. Thus, you have to check what a given CE label specifically covers.

The covered specifications can be very different and a CE label may therefore give the installer a false feeling of security when using a frequency converter as a component in a system or an appliance.

Danfoss CE labels the frequency converters in accordance with the low-voltage directive. This means that if the frequency converter is installed correctly, we guarantee compliance with the low-voltage directive. Danfoss issues a declaration of conformity that confirms our CE labelling in accordance with the low-voltage directive.

The CE label also applies to the EMC directive provided that the instructions for EMC-correct installation and filtering are followed. On this basis, a declaration of conformity in accordance with the EMC directive is issued.

The Design Guide offers detailed instructions for installation to ensure EMC-correct installation. Furthermore,

Danfoss specifies which our different products comply with.

Danfoss provides other types of assistance that can help you obtain the best EMC result.

#### 1.5.4 Compliance with EMC Directive 2004/108/EC

As mentioned, the frequency converter is mostly used by professionals of the trade as a complex component forming part of a larger appliance, system, or installation. It must be noted that the responsibility for the final EMC properties of the appliance, system or installation rests with the installer. As an aid to the installer, Danfoss has prepared EMC installation guidelines for the Power Drive system. The standards and test levels stated for Power Drive systems are complied with, provided that the EMC-correct instructions for installation are followed, see *2.6.3 Immunity Requirements*.

The frequency converter has been designed to meet the IEC/EN 60068-2-3 standard, EN 50178 pkt. 9.4.2.2 at 50°C.

A frequency converter contains a large number of mechanical and electronic components. All are to some extent vulnerable to environmental effects.

### **CAUTION**

**Frequency converters in environments with airborne liquids, particles, or gases capable of affecting and damaging the electronic components. Failure to take the necessary protective measures increases the risk of stoppages, thus reducing the life of the frequency converter.**

#### Degree of protection as per IEC 60529

Liquids can be carried through the air and condense in the frequency converter and may cause corrosion of components and metal parts. Steam, oil, and salt water may cause corrosion of components and metal parts. In such environments, use equipment with enclosure rating IP54/55. As an extra protection, all printed circuit boards are coated.

Airborne Particles such as dust may cause mechanical, electrical, or thermal failure in the frequency converter. A typical indicator of excessive levels of airborne particles is dust particles around the frequency converter fan. In very dusty environments, use equipment with enclosure rating IP54/55 or a cabinet for IP00/IP20/TYP 1 equipment.

In environments with high temperatures and humidity, corrosive gases such as sulphur, nitrogen, and chlorine

compounds will cause chemical processes on the frequency converter components.

Chemical reactions will rapidly affect and damage the electronic components. In such environments, mount the equipment in a cabinet with fresh air ventilation, keeping aggressive gases away from the frequency converter. As an extra protection all printed circuit boards are coated

### NOTE

**Mounting frequency converters in aggressive environments increases the risk of stoppages and considerably reduces the life of the converter.**

Before installing the frequency converter, check the ambient air for liquids, particles, and gases. This is done by observing existing installations in this environment. Typical indicators of harmful airborne liquids are water or oil on metal parts, or corrosion of metal parts.

Excessive dust particle levels are often found on installation cabinets and existing electrical installations. One indicator of aggressive airborne gases is blackening of copper rails and cable ends on existing installations.

The frequency converter has been tested according to the procedure based on the shown standards:

The frequency converter complies with requirements that exist for units mounted on the walls and floors of production premises, as well as in panels bolted to walls or floors.

- IEC/EN 60068-2-6: Vibration (sinusoidal) - 1970
- IEC/EN 60068-2-64: Vibration, broad-band random

## 2 Product Overview

### 2.1 Enclosure Type Overview

Frame size depends on enclosure type, power range and mains voltage.

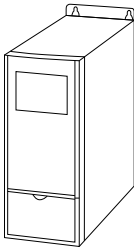
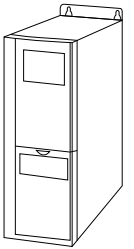
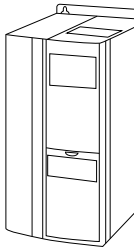
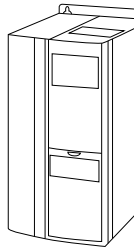
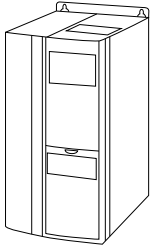
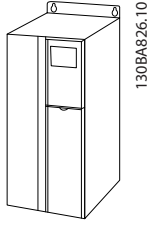
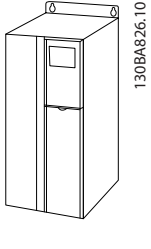
Frame size	<b>J1</b>	<b>J2</b>	<b>J3</b>	<b>J4</b>
	 130BA870.10	 130BA809.10	 130BA810.10	 130BA810.10
Enclosure protection	IP20	IP20	IP20	IP20
High overload rated power - 160% overload torque <sup>1)</sup>	0.37-2.2 kW (380-480 V)	3.0-5.5 kW (380-480 V)	7.5 kW (380-480 V)	11-15 kW (380-480 V)
Frame size	<b>J5</b>	<b>J6</b>	<b>J7</b>	
	 130BA810.10	 130BA826.10	 130BA826.10	
Enclosure protection	IP20	IP20	IP20	
High overload rated power - 160% overload torque	18.5-22 kW (380-480 V)	30-45 kW (380-480 V)	55-75 kW (380-480 V)	

**Table 2.1 Enclosure Types**

<sup>1)</sup> Sizes 11-75 kW also have normal overload (110% overload)

## 2.2 Electrical Installation

2

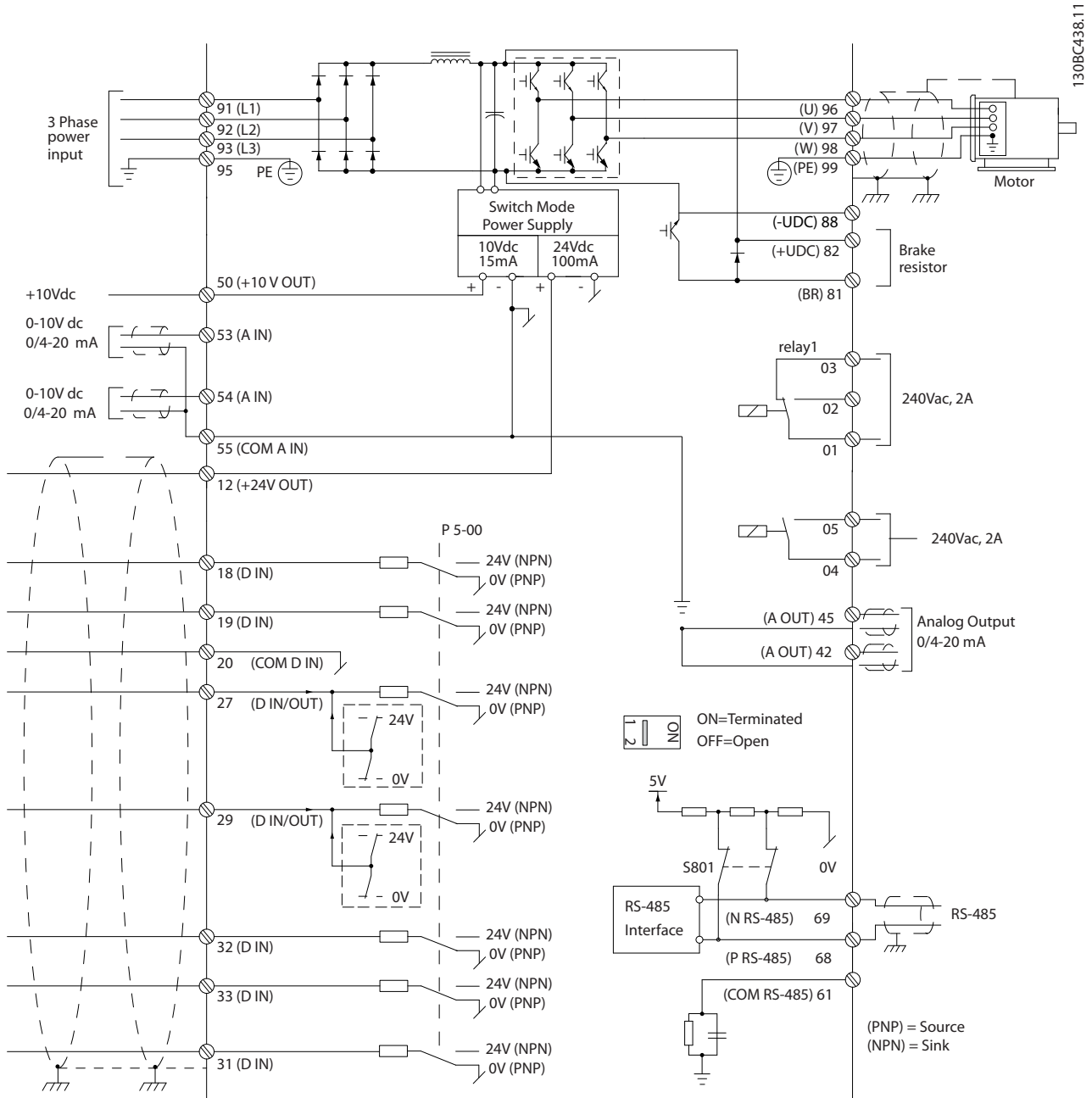

Illustration 2.1 Basic Wiring Schematic Drawing

A=Analog, D=Digital

- 1) Built-in braking chopper available from 0.37 - 22 kW
- 2) Relay 2 is 2 pole for J1-J3 and 3 pole for J4-J7. Relay 2 of J4-J7 with terminal 4,5,6, same NO/NC logic as Relay 1.

## 2.3 Control Structures

### 2.3.1 Control Principle

A frequency converter rectifies AC voltage from mains into DC voltage, after which this DC voltage is converted into a AC current with a variable amplitude and frequency.

The motor is supplied with variable voltage/current and frequency, which enables infinitely variable speed control of three-phased, standard AC motors and permanent magnet synchronous motors.

### 2.3.2 FC 360 Controls

The frequency converter is capable of controlling either the speed or the torque on the motor shaft. Setting *1-00 Configuration Mode* determines the type of control.

#### Speed control

There are two types of speed control:

- Speed closed loop PID control requires a speed feedback to an input. A properly optimised speed closed loop control will have higher accuracy than a speed open loop control.

Selects which input to use as speed PID feedback in *7-00 Speed PID Feedback Source*.

#### Torque control

The torque control function is used in applications where the torque on motor output shaft is controlling the application as tension control. Torque control can be selected in *1-00 Configuration Mode*. Torque setting is done by setting an analog, digital or bus controlled reference. When running torque control it is recommended to make a full AMA procedure as the correct motor data are of high importance for optimal performance.

- Open loop in VVC<sup>plus</sup> mode. The function is used in mechanical robust applications, but the accuracy is limited. Open loop torque function works basically only in one speed direction. The torque is calculated on basic of current measurement internal in the frequency converter. See Application Example Torque open Loop

#### Speed/torque reference

The reference to these controls can either be a single reference or be the sum of various references including relatively scaled references. The handling of references is explained in detail later in this section.

2.3.3 Control Structure in VVC<sup>plus</sup>

2

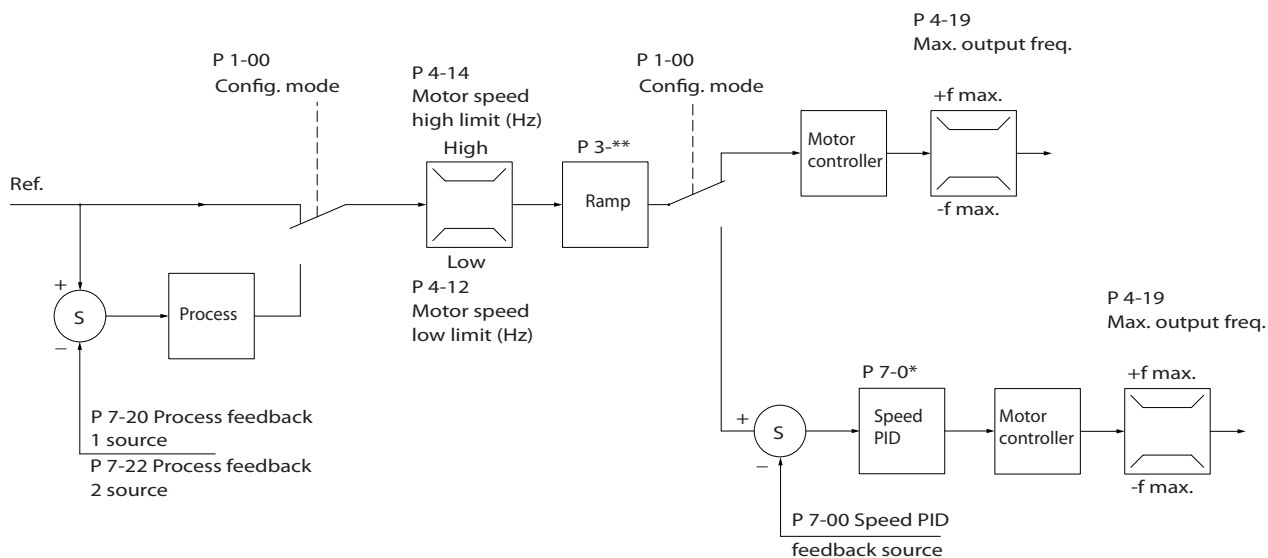

Illustration 2.2 Control Structure in VVC<sup>plus</sup> Open Loop and Closed Loop Configurations

In the configuration shown in *Illustration 2.2*, *1-01 Motor Control Principle* is set to [1] VVC<sup>plus</sup> and *1-00 Configuration Mode* is set to [0] *Speed open loop*. The resulting reference from the reference handling system is received and fed through the ramp limitation and speed limitation before being sent to the motor control. The output of the motor control is then limited by the maximum frequency limit.

If *1-00 Configuration Mode* is set to [1] *Speed closed loop* the resulting reference will be passed from the ramp limitation and speed limitation into a speed PID control. The Speed PID control parameters are located in the parameter group 7-0\* *Speed PID Ctrl.*. The resulting reference from the Speed PID control is sent to the motor control limited by the frequency limit.

Select [3] *Process* in *1-00 Configuration Mode* to use the process PID control for closed loop control of e.g. speed or pressure in the controlled application. The Process PID parameters are located in parameter group 7-2\* *Process Ctrl. Feedb* and 7-3\* *Process PID Ctrl.*.

### 2.3.4 Internal Current Control in VVC<sup>plus</sup> Mode

The frequency converter features an integral current limit control which is activated when the motor current, and thus the torque, is higher than the torque limits set in *4-16 Torque Limit Motor Mode*, *4-17 Torque Limit Generator Mode* and *4-18 Current Limit*.

When the frequency converter is at the current limit during motor operation or regenerative operation, the frequency converter will try to get below the preset torque limits as quickly as possible without losing control of the motor.

### 2.3.5 Local (Hand On) and Remote (Auto On) Control

Operate the frequency converter manually via the local control panel (LCP), local operating panel (LOP) or remotely via analog/digital inputs or serial bus. Start and stop the frequency converter pressing the [Hand On] and [Off/Reset] keys on the LCP. Setup required:

*0-40 [Hand on] Key on LCP,*

*0-44 [Off/Reset] Key on LCP, and*

*0-42 [Auto on] Key on LCP.*

Reset alarms via the [Off/Reset] key or via a digital input, when the terminal is programmed to "Reset".



130B8893.10

**Illustration 2.3 LCP Control Keys**

Local Reference forces the configuration mode to open loop, independent of the setting of *1-00 Configuration Mode*.

Local Reference is restored at power-down.

## 2.4 Reference Handling

### Local reference

The local reference is active when the frequency converter is operated with [Hand On] active. Adjust the reference by [▲]/[▼] and [←]/[→].

### Remote reference

The reference handling system for calculating the Remote reference is shown in *Illustration 2.4*.

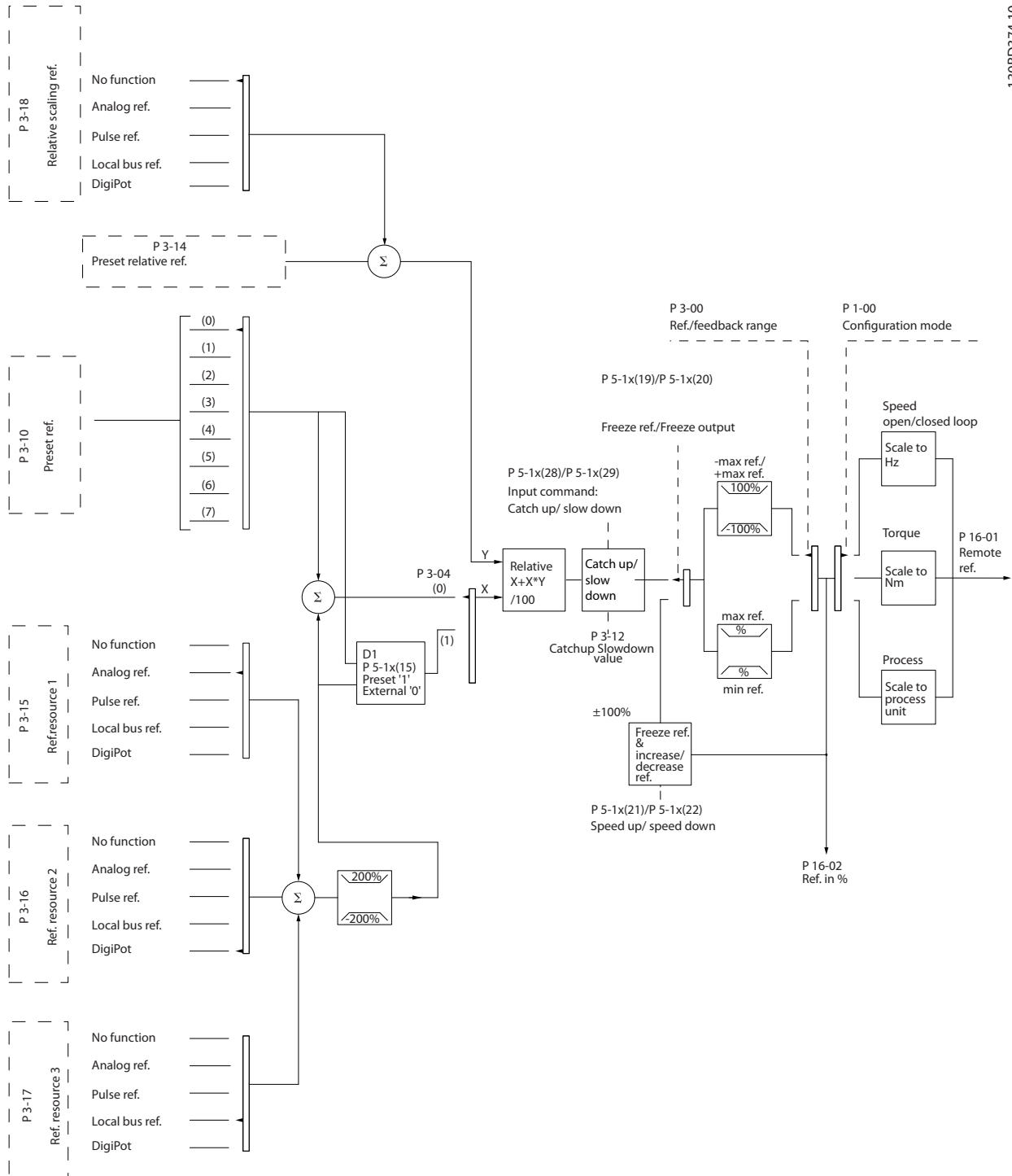

130BD374.10

Illustration 2.4 Remote Reference



The remote reference is calculated once every scan interval and initially consists of two types of reference inputs:

1. X (the external reference): A sum (see 3-04 Reference Function) of up to four externally selected references, comprising any combination (determined by the setting of 3-15 Reference Resource 1, 3-16 Reference Resource 2 and 3-17 Reference Resource 3) of a fixed preset reference (3-10 Preset Reference), variable analog references, variable digital pulse references, and various serial bus references in whatever unit the frequency converter is controlled ([Hz], [RPM], [Nm] etc.).
2. Y- (the relative reference): A sum of one fixed preset reference (3-14 Preset Relative Reference) and one variable analog reference (3-18 Relative Scaling Reference Resource) in [%].

The two types of reference inputs are combined in the following formula: Remote reference =  $X + X * Y / 100\%$ . If relative reference is not used 3-18 Relative Scaling Reference Resource must be set to No function and 3-14 Preset Relative Reference to 0%. The catch up/slow down function and the freeze reference function can both be activated by digital inputs on the frequency converter. The functions and parameters are described in the VLT® AutomationDrive FC 360 Programming Guide.

The scaling of analog references are described in parameter groups 6-1\* Analog Input 53 and 6-2\* Analog Input 54, and the scaling of digital pulse references are described in parameter group 5-5\* Pulse Input. Reference limits and ranges are set in parameter group 3-0\* Reference Limits.

### 2.4.1 Reference Limits

3-00 Reference Range, 3-02 Minimum Reference and 3-03 Maximum Reference together define the allowed range of the sum of all references. The sum of all references are clamped when necessary. The relation between the resulting reference (after clamping) and the sum of all references is shown in Illustration 2.5 and Illustration 2.6.

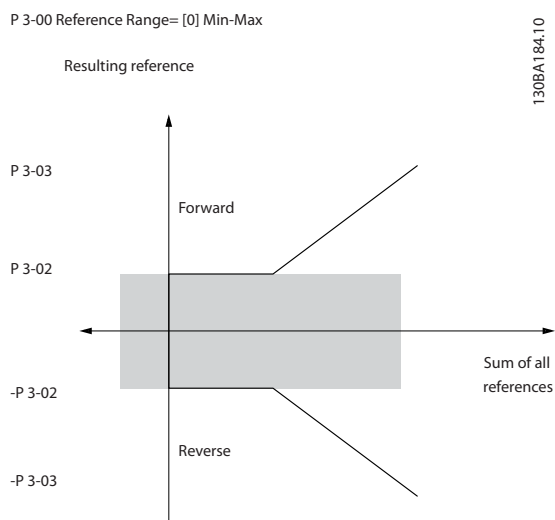

Illustration 2.5 Sum of all References

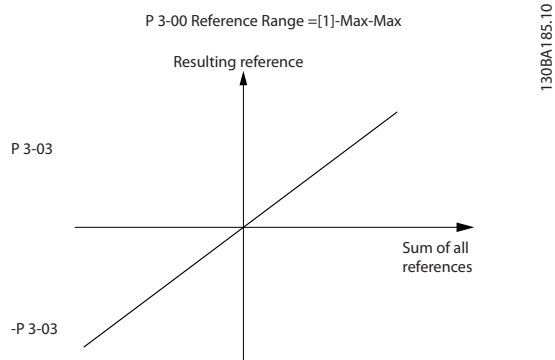

Illustration 2.6 Sum of all References

The value of 3-02 Minimum Reference can not be set to less than 0, unless 1-00 Configuration Mode is set to [3] Process. In that case the following relations between the resulting reference (after clamping) and the sum of all references is as shown in Illustration 2.7.

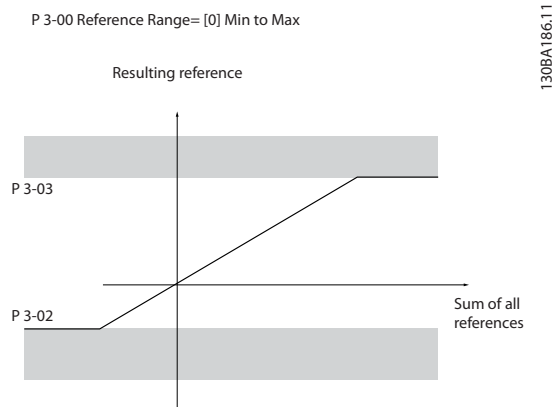

Illustration 2.7 Sum of all References

### 2.4.2 Scaling of Preset References and Bus References

Preset references are scaled according to the following rules:

- When 3-00 Reference Range : [0] Min - Max 0% reference equals 0 [unit] where unit can be any unit e.g. rpm, m/s, bar etc. 100% reference equals the Max (abs (3-03 Maximum Reference ), abs (3-02 Minimum Reference)).
- When 3-00 Reference Range : [1] -Max - +Max 0% reference equals 0 [unit] -100% reference equals - Max Reference 100% reference equals Max Reference.

Bus references are scaled according to the following rules:

- When 3-00 Reference Range: [0] Min - Max. To obtain max resolution on the bus reference the scaling on the bus is: 0% reference equals Min Reference and 100% reference equals Max reference.
- When 3-00 Reference Range: [1] -Max - +Max -100% reference equals -Max Reference 100% reference equals Max Reference.

### 2.4.3 Scaling of Analog and Pulse References and Feedback

References and feedback are scaled from analog and pulse inputs in the same way. The only difference is that a reference above or below the specified minimum and maximum “endpoints” (P1 and P2 in *Illustration 2.8*) are clamped whereas a feedback above or below is not.

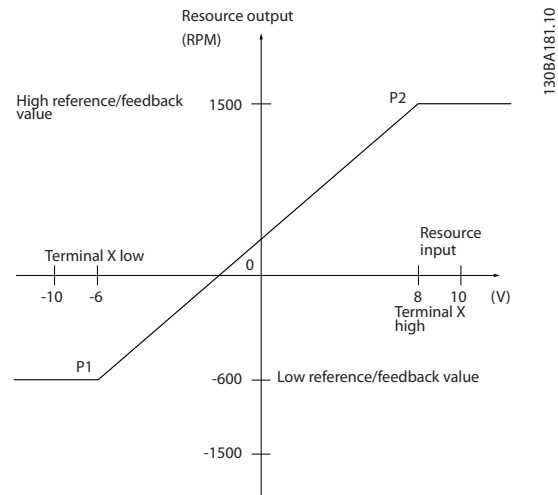

Illustration 2.8 Minimum and Maximum Endpoints

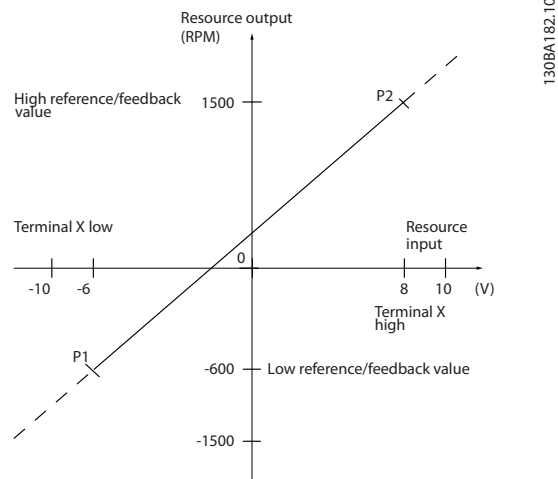

Illustration 2.9 Scaling of Analog and Pulse References and Feedback

The endpoints P1 and P2 are defined by the following parameters depending on choice of input.

Input	Analog 53 voltage mode	Analog 53 current mode	Analog 54 voltage mode	Analog 54 current mode	Pulse Input 29	Pulse Input 33
P1 = (Minimum input value, Minimum reference value)						
Minimum reference value	6-14 Terminal 53 Low Ref./Feedb. Value	6-14 Terminal 53 Low Ref./Feedb. Value	6-24 Terminal 54 Low Ref./Feedb. Value	6-24 Terminal 54 Low Ref./Feedb. Value	5-52 Term. 29 Low Ref./Feedb. Value	5-57 Term. 33 Low Ref./Feedb. Value
Minimum input value	6-10 Terminal 53 Low Voltage [V]	6-12 Terminal 53 Low Current [mA]	6-20 Terminal 54 Low Voltage [V]	6-22 Terminal 54 Low Current [mA]	5-50 Term. 29 Low Frequency [Hz]	5-55 Term. 33 Low Frequency [Hz]
P2 = (Maximum input value, Maximum reference value)						
Maximum reference value	6-15 Terminal 53 High Ref./Feedb. Value	6-15 Terminal 53 High Ref./Feedb. Value	6-25 Terminal 54 High Ref./Feedb. Value	6-25 Terminal 54 High Ref./Feedb. Value	5-53 Term. 29 High Ref./Feedb. Value	5-58 Term. 33 High Ref./Feedb. Value
Maximum input value	6-11 Terminal 53 High Voltage [V]	6-13 Terminal 53 High Current [mA]	6-21 Terminal 54 High Voltage[V]	6-23 Terminal 54 High Current [mA]	5-51 Term. 29 High Frequency [Hz]	5-56 Term. 33 High Frequency [Hz]

**Table 2.2 P1 and P2 Endpoints**

2

2.4.4 Dead Band Around Zero

In some cases the reference (in rare cases also the feedback) should have a dead band around zero (i.e. to make sure the machine is stopped when the reference is “near zero”).

To make the dead band active and to set the amount of dead band, the following settings must be done:

- Either minimum reference value (see Table 2.2 for relevant parameter) or maximum reference value must be zero. In other words; Either P1 or P2 must be on the X-axis in Illustration 2.10 and .
- And both points defining the scaling graph are in the same quadrant.

The size of the Dead Band is defined by either P1 or P2 as shown in Illustration 2.10.

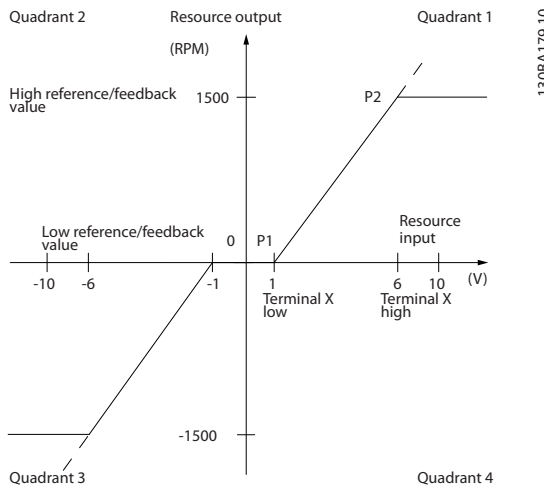

Illustration 2.10 Size of Deadband

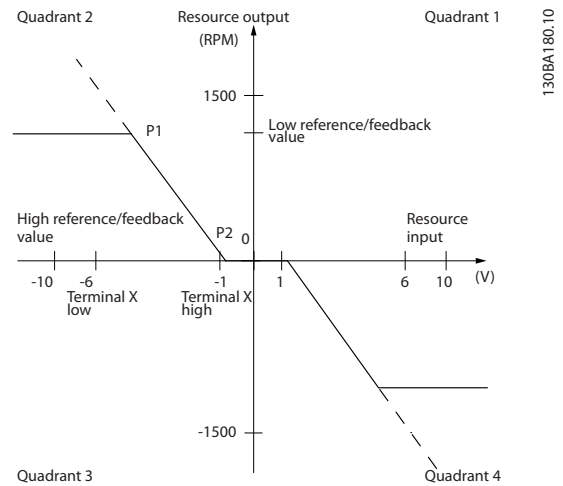
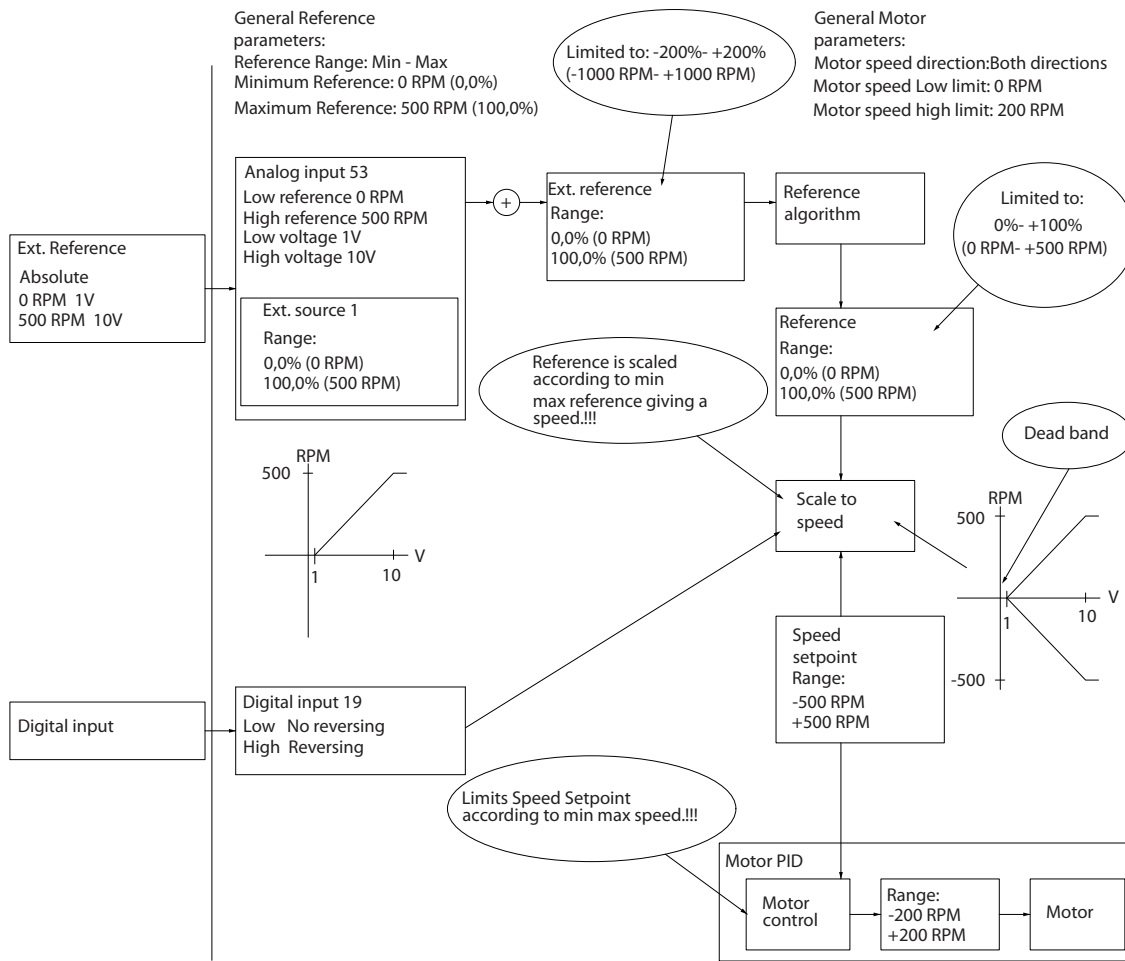

Illustration 2.11 Size of Deadband

Thus a reference endpoint of P1 = (0 V, 0 RPM) will not result in any dead band, but a reference endpoint of e.g. P1 = (1 V, 0 RPM) will result in a -1 V to +1 V dead band in this case provided that the end point P2 is placed in either quadrant 1 or quadrant 4.

Case 1: Positive reference with dead band, digital input to trigger reverse

Illustration 2.12 shows how reference input with limits inside Min – Max limits clamps.



130BA187.11

Illustration 2.12 Clamping of Reference Input with Limits inside Min - Max

**Case 2: Positive reference with dead band, digital input to trigger reverse. Clamping rules.**

Illustration 2.13 shows how reference input with limits outside -Max – +Max limits clamps to the inputs low and high limits before addition to external reference. And how the external reference is clamped to -Max – +Max by the Reference algorithm.

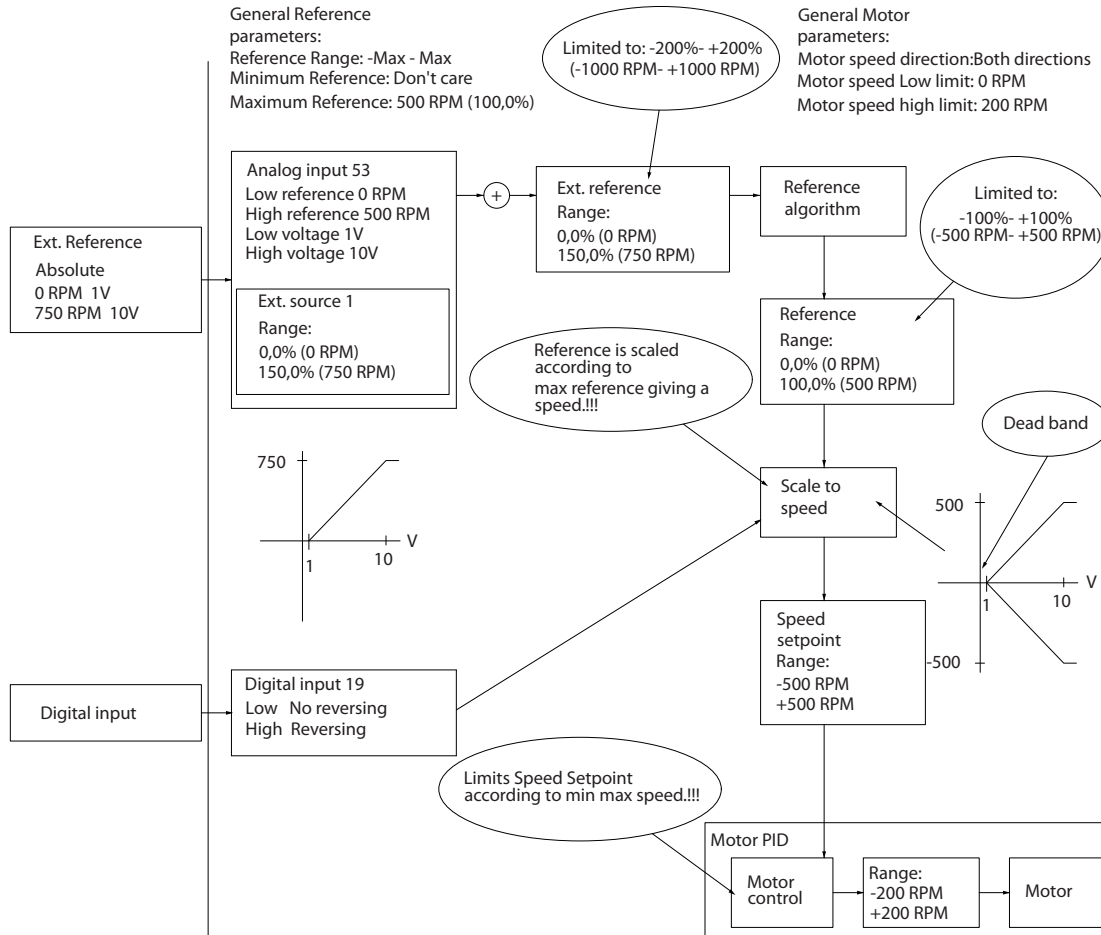

130BA188.13

Illustration 2.13 Clamping of Reference Input with Limits outside -Min – +Max

Case 3: Negative to positive reference with dead band, sign determines the direction, -Max – +Max

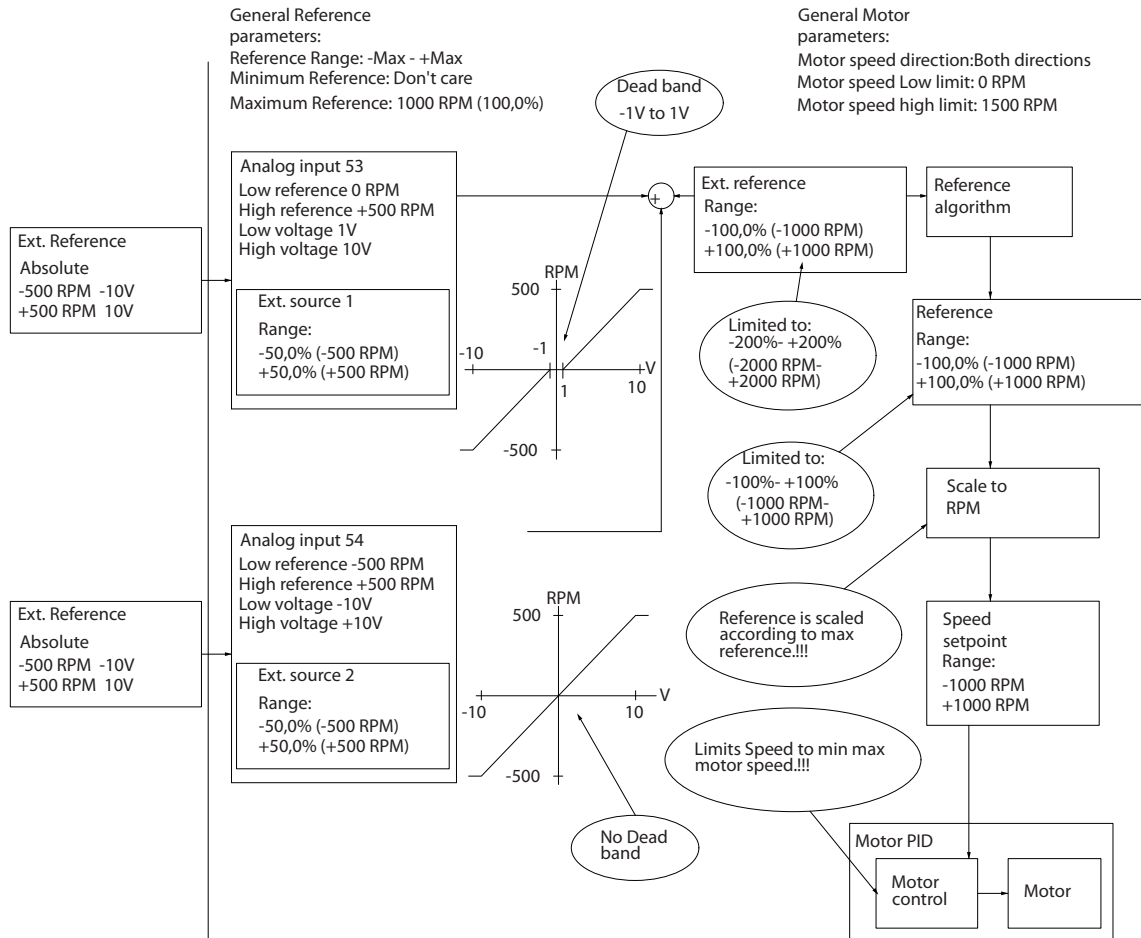

130BA189.12

Illustration 2.14 Negative to Positive Reference with Dead Band

## 2.5 PID Control

### 2.5.1 Speed PID Control

1-00 Configuration Mode	1-01 Motor Control Principle	
	U/f	VVC <sup>plus</sup>
[0] Speed open loop	Not Active	Not Active
[1] Speed closed loop	N.A.	ACTIVE
[2] Torque	N.A.	N.A.
[3] Process		Not Active

**Table 2.3 Control Configurations, Active Speed Control**

"N.A." means that the specific mode is not available at all. "Not Active" means that the specific mode is available but the Speed Control is not active in that mode.

The following parameters are relevant for the Speed Control:

Parameter	Description of function	
7-00 Speed PID Feedback Source	Select from which input the Speed PID should get its feedback.	
7-02 Speed PID Proportional Gain	The higher the value - the quicker the control. However, too high value may lead to oscillations.	
7-03 Speed PID Integral Time	Eliminates steady state speed error. Lower value means quick reaction. However, too low value may lead to oscillations.	
7-04 Speed PID Differentiation Time	Provides a gain proportional to the rate of change of the feedback. A setting of zero disables the differentiator.	
7-05 Speed PID Diff. Gain Limit	If there are quick changes in reference or feedback in a given application - which means that the error changes swiftly - the differentiator may soon become too dominant. This is because it reacts to changes in the error. The quicker the error changes, the stronger the differentiator gain is. The differentiator gain can thus be limited to allow setting of the reasonable differentiation time for slow changes and a suitably quick gain for quick changes.	
7-06 Speed PID Lowpass Filter Time	A low-pass filter that dampens oscillations on the feedback signal and improves steady state performance. However, too large filter time will deteriorate the dynamic performance of the Speed PID control. Practical settings of parameter 7-06 taken from the number of pulses per revolution on from encoder (PPR):	
	<b>Encoder PPR</b>	<b>7-06 Speed PID Lowpass Filter Time</b>
	512	10 ms
	1024	5 ms
	2048	2 ms
4096	1 ms	

**Table 2.4 Speed Control Parameters**



**Example of how to Programme the Speed Control**

In this case the Speed PID Control is used to maintain a constant motor speed regardless of the changing load on the motor. The required motor speed is set via a potentiometer connected to terminal 53. The speed range is 0-1500 RPM corresponding to 0-10 V over the potentiometer. Starting and stopping is controlled by a switch connected to terminal 18. The Speed PID monitors the actual RPM of the motor by using a 24 V (HTL) incremental encoder as feedback. The feedback sensor is an encoder (1024 pulses per revolution) connected to terminals 32 and 33. The pulse frequency range to terminals 32 and 33 is 4-32 kHz

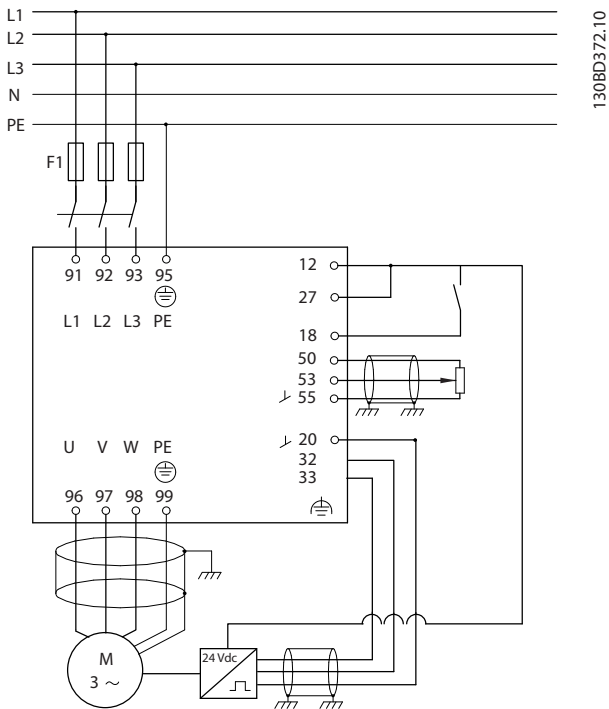

**Illustration 2.15 Speed Control Programming**

The following must be programmed in order shown (see explanation of settings in the *VLT® AutomationDrive FC 360 Programming Guide*)

In *Table 2.5* it is assumed that all other parameters and switches remain at their default setting.

Function	Parameter no.	Setting
1) Make sure the motor runs properly. Do the following:		
Set the motor parameters using name plate data	1-2*	As specified by motor name plate
Have the frequency converter makes an Automatic Motor Adaptation	1-29 Automatic Motor Adaptation (AMA)	[1] Enable complete AMA
2) Check the motor is running and the encoder is attached properly. Do the following:		
Press [Hand On]. Check that the motor is running and note in which direction it is turning (henceforth referred to as the "positive direction").		Set a <b>positive</b> reference.
Go to <i>16-20 Motor Angle</i> . Turn the motor slowly in the positive direction. It must be turned so slowly (only a few RPM) that it can be determined if the value in <i>16-20 Motor Angle</i> is increasing or decreasing.	16-20 Motor Angle	N.A. (read-only parameter) Note: An increasing value overflows at 65535 and starts again at 0.
If <i>16-20 Motor Angle</i> is decreasing then change the encoder direction in <i>5-71 Term 32/33 Encoder Direction</i> .	5-71 Term 32/33 Encoder Direction	[1] Counter clockwise (if <i>16-20 Motor Angle</i> is decreasing)
3) Make sure the drive limits are set to safe values		
Set acceptable limits for the references.	3-02 Minimum Reference 3-03 Maximum Reference	0 1500
Check that the ramp settings are within drive capabilities and allowed application operating specifications.	3-41 Ramp 1 Ramp Up Time 3-42 Ramp 1 Ramp Down Time	default setting default setting
Set acceptable limits for the motor speed and frequency.	4-12 Motor Speed Low Limit [Hz] 4-14 Motor Speed High Limit [Hz] 4-19 Max Output Frequency	0 Hz 50 Hz 50 Hz
4) Configure the Speed Control and select the Motor Control principle		
Activation of Speed Control	1-00 Configuration Mode	[1] Speed closed loop
Selection of Motor Control Principle	1-01 Motor Control Principle	[1] VVC+
5) Configure and scale the reference to the Speed Control		
Set up Analog Input 53 as a reference Source	3-15 Reference Resource 1	Not necessary (default)
Scale Analog Input 53 0 RPM (0 V) to 1500 RPM (10 V)	6-1*	Not necessary (default)
6) Configure the 24 V HTL encoder signal as feedback for the Motor Control and the Speed Control		
Set up digital input 32 and 33 as encoder inputs	5-14 Terminal 32 Digital Input 5-15 Terminal 33 Digital Input	[0] No operation (default)
Choose terminal 32/33 as Speed PID feedback	7-00 Speed PID Feedback Source	Not necessary (default)
7) Tune the Speed Control PID parameters		
Use the tuning guidelines when relevant or tune manually	7-0*	See the guidelines below
8) Finished!		
Save the parameter setting to the LCP for safe keeping	0-50 LCP Copy	[1] All to LCP

**Table 2.5 Programming Order**

### 2.5.2 Process PID Control

The Process PID Control can be used to control application parameters that can be measured by a sensor (i.e. pressure, temperature, flow) and be affected by the connected motor through a pump, fan or otherwise.

Table 2.6 shows the control configurations where the Process Control is possible. Refer to 2.3 Control Structures to see where the Speed Control is active.

1-00 Configuration Mode	1-01 Motor Control Principle	
	U/f	VVC <sup>plus</sup>
[3] Process	N.A.	Process

Table 2.6 Control Configuration

### NOTE

The Process Control PID will work under the default parameter setting, but tuning the parameters is highly recommended to optimise the application control performance.

2

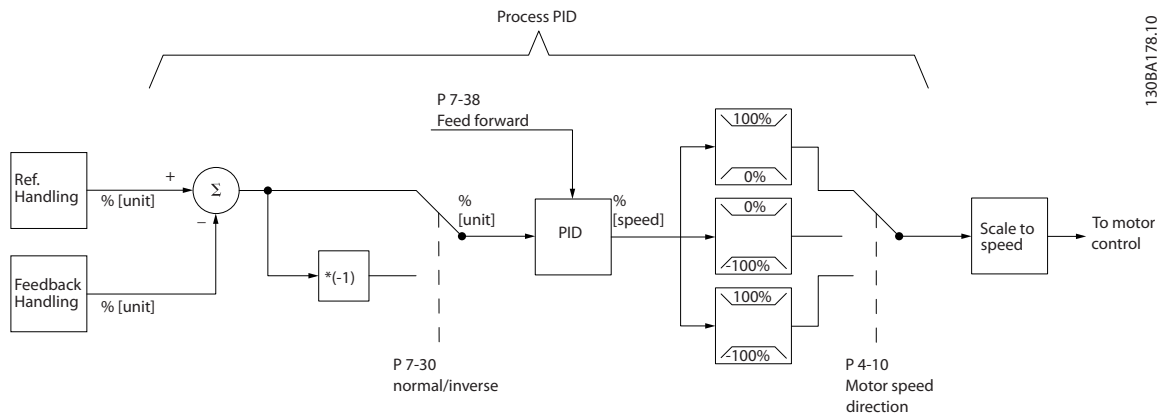

Illustration 2.16 Process PID Control Diagram

The following parameters are relevant for the Process Control

2

Parameter	Description of function
7-20 Process CL Feedback 1 Resource	Select from which Source (i.e. analog or pulse input) the Process PID should get its feedback
7-22 Process CL Feedback 2 Resource	Optional: Determine if (and from where) the Process PID should get an additional feedback signal. If an additional feedback source is selected the two feedback signals will be added together before being used in the Process PID Control.
7-30 Process PID Normal/ Inverse Control	Under [0] <i>Normal</i> operation the Process Control will respond with an increase of the motor speed if the feedback is getting lower than the reference. In the same situation, but under [1] <i>Inverse</i> operation, the Process Control will respond with a decreasing motor speed instead.
7-31 Process PID Anti Windup	The anti windup function ensures that when either a frequency limit or a torque limit is reached, the integrator will be set to a gain that corresponds to the actual frequency. This avoids integrating on an error that cannot in any case be compensated for by means of a speed change. This function can be disabled by selecting [0] <i>Off</i> .
7-32 Process PID Start Speed	In some applications, reaching the required speed/set point can take a very long time. In such applications it might be an advantage to set a fixed motor speed from the frequency converter before the process control is activated. This is done by setting a Process PID Start Value (speed) in 7-32 <i>Process PID Start Speed</i> .
7-33 Process PID Proportional Gain	The higher the value, the quicker the control. However, too large value may lead to oscillations.
7-34 Process PID Integral Time	Eliminates steady state speed error. Lower value means quick reaction. However, too small value may lead to oscillations.
7-35 Process PID Differentiation Time	Provides a gain proportional to the rate of change of the feedback. A setting of zero disables the differentiator.
7-36 Process PID Diff. Gain Limit	If there are quick changes in reference or feedback in a given application - which means that the error changes swiftly - the differentiator may soon become too dominant. This is because it reacts to changes in the error. The quicker the error changes, the stronger the differentiator gain is. The differentiator gain can thus be limited to allow setting of the reasonable differentiation time for slow changes.
7-38 Process PID Feed Forward Factor	In application where there is a good (and approximately linear) correlation between the process reference and the motor speed necessary for obtaining that reference, the Feed Forward Factor can be used to achieve better dynamic performance of the Process PID Control.
5-54 Pulse Filter Time Constant #29 (Pulse term. 29), 5-59 Pulse Filter Time Constant #33 (Pulse term. 33), 6-16 Terminal 53 Filter Time Constant (Analog term 53), 6-26 Terminal 54 Filter Time Constant (Analog term. 54)	<p>If there are oscillations of the current/voltage feedback signal, these can be dampened by means of a low-pass filter. This time constant represents the speed limit of the ripples occurring on the feedback signal.</p> <p>Example: If the low-pass filter has been set to 0.1 s, the limit speed will be 10 RAD/s (the reciprocal of 0.1 s), corresponding to <math>(10/(2 \times \pi)) = 1.6</math> Hz. This means that all currents/voltages that vary by more than 1.6 oscillations per second will be damped by the filter. The control will only be carried out on a feedback signal that varies by a frequency (speed) of less than 1.6 Hz.</p> <p>The low-pass filter improves steady state performance but selecting a too large filter time will deteriorate the dynamic performance of the Process PID Control.</p>

Table 2.7 Process Control Parameters

### 2.5.3 Example of Process PID Control

Illustration 2.17 is an example of a Process PID Control used in a ventilation system:

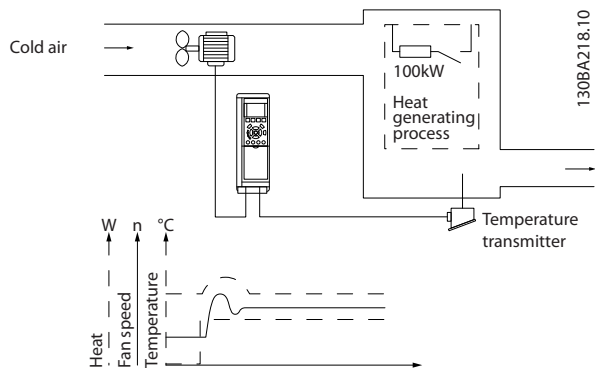

Illustration 2.17 Process PID Control in a Ventilation System

In a ventilation system, the temperature is to be settable from - 5 to 35 °C with a potentiometer of 0-10 V. The set temperature must be kept constant, for which purpose the Process Control is to be used.

The control is of the inverse type, which means that when the temperature increases, the ventilation speed is increased as well, so as to generate more air. When the temperature drops, the speed is reduced. The transmitter used is a temperature sensor with a working range of -10 to 40 °C, 4-20 mA. Min./Max. speed 300/1500 RPM.

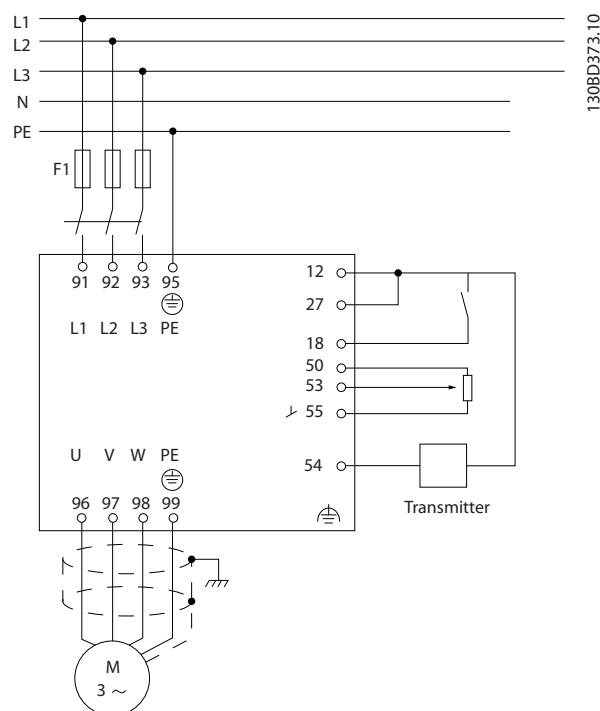

Illustration 2.18 Two-wire Transmitter

1. Start/Stop via switch connected to terminal 18.
2. Temperature reference via potentiometer (-5 to 35 °C, 0-10 V DC) connected to terminal 53.
3. Temperature feedback via transmitter (-10 to 40 °C, 4-20 mA) connected to terminal 54.

Function	Par. no.	Setting
Initialize the frequency converter	14-22	[2] Initialization - make a power cycling - press reset
1) Set motor parameters:		
Set the motor parameters according to name plate data	1-2*	As stated on motor name plate
Perform a full <b>Automation Motor Adaptation</b>	1-29	[1] Enable complete AMA
2) Check that motor is running in the right direction. When motor is connected to frequency converter with straight forward phase order as U - U; V- V; W - W motor shaft usually turns clockwise seen into shaft end.		
Press [Hand On]. Check shaft direction by applying a manual reference.		
If motor turns opposite of required direction: 1. Change motor direction in <i>4-10 Motor Speed Direction</i> 2. Turn off mains - wait for DC link to discharge - switch two of the motor phases	4-10	Select correct motor shaft direction
Set configuration mode	1-00	[3] Process
3) Set reference configuration, ie. the range for reference handling. Set scaling of analog input in parameter 6-xx		
Set reference/feedback units	3-01	[60] ° C Unit shown on display
Set min. reference (10 °C)	3-02	-5° C
Set max. reference (80 °C)	3-03	35° C
If set value is determined from a preset value (array parameter), set other reference sources to No Function	3-10	[0] 35% $Ref = \frac{Par. 3 - 10(0)}{100} \times ((Par. 3 - 03) - (par. 3 - 02)) = 24, 5^{\circ} C$ 3-14 Preset Relative Reference to 3-18 Relative Scaling Reference Resource [0] = No Function
4) Adjust limits for the frequency converter:		
Set ramp times to an appropriate value as 20 s	3-41	20 s
	3-42	20 s
Set min. speed limits	4-12	10 Hz
Set motor speed max. limit	4-14	50 Hz
Set max. output frequency	4-19	50 Hz
Set 6-19 <i>Terminal 53 mode</i> and 6-29 <i>Terminal 54 mode</i> to voltage or current mode.		
5) Scale analog inputs used for reference and feedback		
Set terminal 53 low voltage	6-10	0V
Set terminal 53 high voltage	6-11	10V
Set terminal 54 low feedback value	6-24	-5° C
Set terminal 54 high feedback value	6-25	35° C
Set feedback source	7-20	[2] Analog input 54
6) Basic PID settings		
Process PID Normal/Inverse	7-30	[0] Normal
Process PID Anti Wind-up	7-31	[1] On
Process PID start speed	7-32	300 rpm
Save parameters to LCP	0-50	[1] All to LCP

Table 2.8 Example of Process PID Control set-up

Optimisation of the process regulator

The basic settings have now been made; all that needs to be done is to optimise the proportional gain, the integration time and the differentiation time (7-33 Process PID Proportional Gain, 7-34 Process PID Integral Time, 7-35 Process PID Differentiation Time). In most processes, this can be done by following the guidelines given below.

1. Start the motor
2. Set 7-33 Process PID Proportional Gain to 0.3 and increase it until the feedback signal again begins to vary continuously. Then reduce the value until the feedback signal has stabilised. Now lower the proportional gain by 40-60%.
3. Set 7-34 Process PID Integral Time to 20 s and reduce the value until the feedback signal again begins to vary continuously. Increase the integration time until the feedback signal stabilises, followed by an increase of 15-50%.
4. Only use 7-35 Process PID Differentiation Time for very fast-acting systems only (differentiation time). The typical value is four times the set integration time. The differentiator should only be used when the setting of the proportional gain and the integration time has been fully optimised. Make sure that oscillations on the feedback signal is sufficiently dampened by the lowpass filter on the feedback signal.

**NOTE**

If necessary, start/stop can be activated a number of times in order to provoke a variation of the feedback signal.

2.5.4 Ziegler Nichols Tuning Method

In order to tune the PID controls of the frequency converter, several tuning methods can be used. One approach is to use a technique which was developed in the 1950s but which has stood the test of time and is still used today. This method is known as the Ziegler Nichols tuning method.

**NOTE**

The method described must not be used on applications that could be damaged by the oscillations created by marginally stable control settings.

The criteria for adjusting the parameters are based on evaluating the system at the limit of stability rather than on taking a step response. Increase the proportional gain until observing continuous oscillations (as measured on the feedback), that is, until the system becomes marginally stable. The corresponding gain ( $K_u$ ) is called the ultimate

gain. The period of the oscillation ( $P_u$ ) (called the ultimate period) is determined as shown in Illustration 2.19.

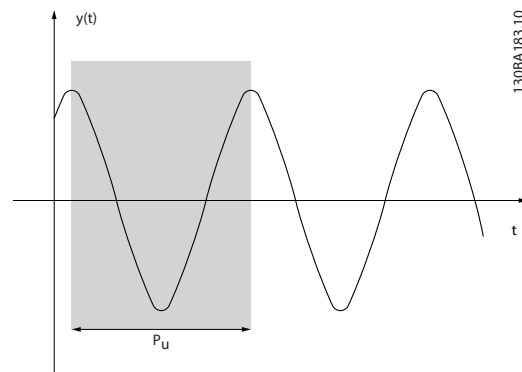

Illustration 2.19 Marginally Stable System

$P_u$  should be measured when the amplitude of oscillation is quite small. Then we “back off” from this gain again, as shown in Table 2.9.

$K_u$  is the gain at which the oscillation is obtained.

Type of Control	Proportional Gain	Integral Time	Differentiation Time
PI-control	$0.45 * K_u$	$0.833 * P_u$	-
PID tight control	$0.6 * K_u$	$0.5 * P_u$	$0.125 * P_u$
PID some overshoot	$0.33 * K_u$	$0.5 * P_u$	$0.33 * P_u$

Table 2.9 Ziegler Nichols Tuning for Regulator

Experience has shown that the control setting according to Ziegler Nichols rule provides a good closed loop response for many systems. The process operator can do the final tuning of the control iteratively to yield satisfactory control.

**Step-by-step Description:**

**Step 1:** Select only Proportional Control, meaning that the Integral time is selected to the maximum value, while the differentiation time is selected to zero.

**Step 2:** Increase the value of the proportional gain until the point of instability is reached (sustained oscillations) and the critical value of gain,  $K_u$ , is reached.

**Step 3:** Measure the period of oscillation to obtain the critical time constant,  $P_u$ .

**Step 4:** Use the table above to calculate the necessary PID control parameters.

## 2.6 General Aspects of EMC

### 2.6.1 General Aspects of EMC Emissions

Electrical interference is usually conducted at frequencies in the range 150 kHz to 30 MHz. Airborne interference from the frequency converter system in the range 30 MHz to 1G Hz is generated from the inverter, motor cable and the motor. As shown in *Illustration 2.20*, capacitive currents in the motor cable coupled with a high  $dU/dt$  from the motor voltage generate leakage currents.

The use of a screened motor cable increases the leakage current (see *Illustration 2.20*) because screened cables have higher capacitance to earth than unscreened cables. If the leakage current is not filtered, it will cause greater interference on the mains in the radio frequency range below approximately 5 MHz. Since the leakage current ( $I_1$ ) is carried back to the unit through the screen ( $I_3$ ), there will in principle only be a small electro-magnetic field ( $I_4$ ) from the screened motor cable according to *Illustration 2.20*.

The screen reduces the radiated interference but increases the low-frequency interference on the mains. The motor cable screen must be connected to the frequency converter enclosure as well as on the motor enclosure. This is best done by using integrated screen clamps so as to avoid twisted screen ends (pigtailed). These increase the screen impedance at higher frequencies, which reduces the screen effect and increases the leakage current ( $I_4$ ).

If a screened cable is used for fieldbus, relay, control cable, signal interface and brake, the screen must be mounted on the enclosure at both ends. In some situations, however, it will be necessary to break the screen to avoid current loops.

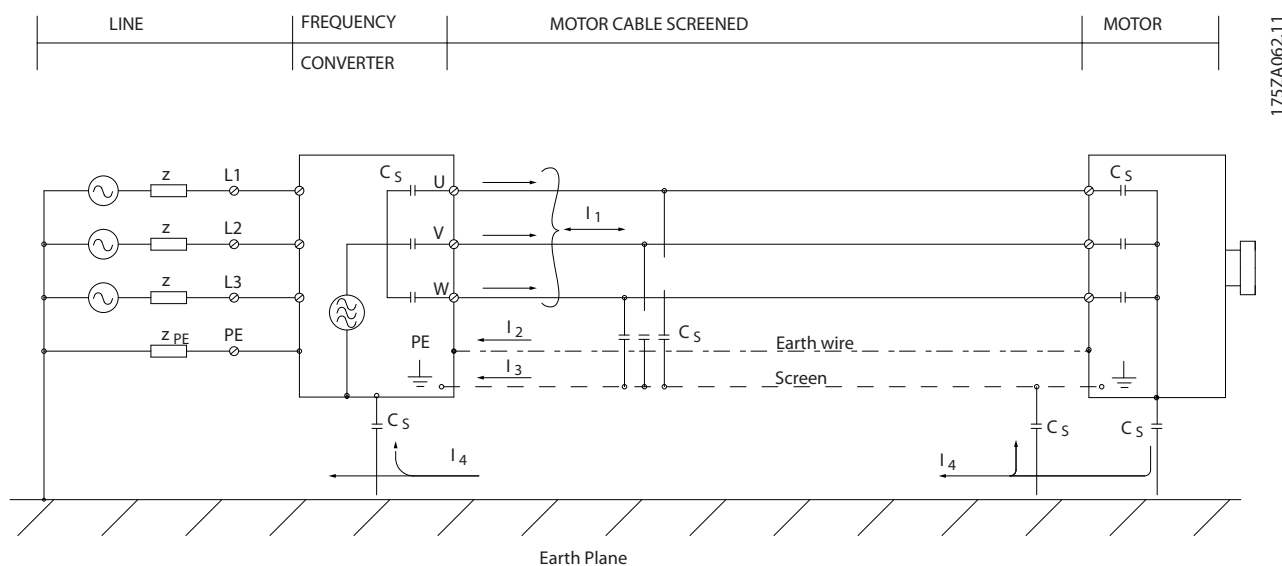

Illustration 2.20 EMC Emission

If the screen is to be placed on a mounting plate for the frequency converter, the mounting plate must be made of metal, because the screen currents have to be conveyed back to the unit. Moreover, ensure good electrical contact from the mounting plate through the mounting screws to the frequency converter chassis.

When unscreened cables are used, some emission requirements are not complied with, although the immunity requirements are observed.

To reduce the interference level from the entire system (unit + installation), make motor and brake cables as short as possible. Avoid placing cables with a sensitive signal level alongside motor and brake cables. Radio interference higher than 50 MHz (airborne) is especially generated by the control electronics.



## 2.6.2 EMC Test Results

The test results in *Table 2.10* have been obtained using a system with a frequency converter (with options if relevant), a screened control cable, a control box with potentiometer, as well as a motor and motor screened cable.

RFI filter type		Conducted emission	Radiated emission
Standards and requirements	EN 55011	<b>Class A Group 2</b> Industrial environment	<b>Class A Group 1</b> Industrial environment
	EN/IEC 61800-3	<b>Category C3</b> Second environment Industrial	<b>Category C2</b> First environment Home and office
<b>J1</b>	0.37-2.2 kW, 380-480 V	25 m	Yes
<b>J2</b>	3.0-5.5 kW, 380-480 V	25 m	Yes
<b>J3</b>	7.5 kW, 380-480 V	25 m	Yes

**Table 2.10 EMC Test Results (Emission, Immunity)**

## 2.6.3 Immunity Requirements

**2**

The immunity requirements for frequency converters depend on the environment where they are installed. The requirements for the industrial environment are higher than the requirements for the home and office environment. All Danfoss frequency converters comply with the requirements for the industrial environment and consequently comply also with the lower requirements for home and office environment with a large safety margin.

To document immunity against electrical interference from electrical phenomena, the following immunity tests have been made on a system consisting of a frequency converter (with options if relevant), a screened control cable and a control box with potentiometer, motor cable and motor.

The tests were performed in accordance with the following basic standards:

- **EN 61000-4-2 (IEC 61000-4-2):** Electrostatic discharges (ESD): Simulation of electrostatic discharges from human beings.
- **EN 61000-4-3 (IEC 61000-4-3):** Incoming electromagnetic field radiation, amplitude modulated simulation of the effects of radar and radio communication equipment as well as mobile communications equipment.
- **EN 61000-4-4 (IEC 61000-4-4):** Burst transients: Simulation of interference brought about by switching a contactor, relay or similar devices.
- **EN 61000-4-5 (IEC 61000-4-5):** Surge transients: Simulation of transients brought about e.g. by lightning that strikes near installations.
- **EN 61000-4-6 (IEC 61000-4-6):** RF Common mode: Simulation of the effect from radio-transmission equipment joined by connection cables.

See Table 2.11.

Voltage range: 380-480 V					
Basic standard	Burst IEC 61000-4-4	Surge IEC 61000-4-5	ESD IEC 61000-4-2	Radiated electromagnetic field IEC 61000-4-3	RF common mode voltage IEC 61000-4-6
Acceptance criterion	B	B	B	A	A
Line	4 kV CM	2 kV/2 Ω DM 4 kV/12 Ω CM	—	—	10 V <sub>RMS</sub>
Motor	4 kV CM	4 kV/2 Ω <sup>1)</sup>	—	—	10 V <sub>RMS</sub>
Brake	4 kV CM	4 kV/2 Ω <sup>1)</sup>	—	—	10 V <sub>RMS</sub>
Load sharing	4 kV CM	4 kV/2 Ω <sup>1)</sup>	—	—	10 V <sub>RMS</sub>
Control wires	2 kV CM	2 kV/2 Ω <sup>1)</sup>	—	—	10 V <sub>RMS</sub>
Standard bus	2 kV CM	2 kV/2 Ω <sup>1)</sup>	—	—	10 V <sub>RMS</sub>
Relay wires	2 kV CM	2 kV/2 Ω <sup>1)</sup>	—	—	10 V <sub>RMS</sub>
Application and Fieldbus options	2 kV CM	2 kV/2 Ω <sup>1)</sup>	—	—	10 V <sub>RMS</sub>
LCP cable	2 kV CM	2 kV/2 Ω <sup>1)</sup>	—	—	10 V <sub>RMS</sub>
External 24 V DC	2 V CM	0.5 kV/2 Ω DM 1 kV/12 Ω CM	—	—	10 V <sub>RMS</sub>
Enclosure	—	—	8 kV AD 6 kV CD	10V/m	—

**Table 2.11 EMC Immunity Form**

1) Injection on cable shield

AD: Air Discharge

CD: Contact Discharge

CM: Common mode

DM: Differential mode

### 2.7.1 PELV - Protective Extra Low Voltage

PELV offers protection by way of extra low voltage. Protection against electric shock is ensured when the electrical supply is of the PELV type and the installation is made as described in local/national regulations on PELV supplies.

All control terminals and relay terminals 01-03/04-06 comply with PELV (Protective Extra Low Voltage) (Does not apply to grounded Delta leg above 400 V).

Galvanic (ensured) isolation is obtained by fulfilling requirements for higher isolation and by providing the relevant creepage/clearance distances. These requirements are described in the EN 61800-5-1 standard.

The components that make up the electrical isolation, as described below, also comply with the requirements for higher isolation and the relevant test as described in EN 61800-5-1.

The PELV galvanic isolation can be shown in six locations (see *Illustration 2.21*):

In order to maintain PELV all connections made to the control terminals must be PELV, e.g. thermistor must be reinforced/double insulated.

1. Power supply (SMPS) incl. signal isolation of  $U_{DC}$ , indicating the intermediate current voltage.
2. Gate drive that runs the IGBTs (trigger transformers/opto-couplers).
3. Current transducers.
4. Opto-coupler, brake module.
5. Internal inrush, RFI, and temperature measurement circuits.
6. Custom relays.

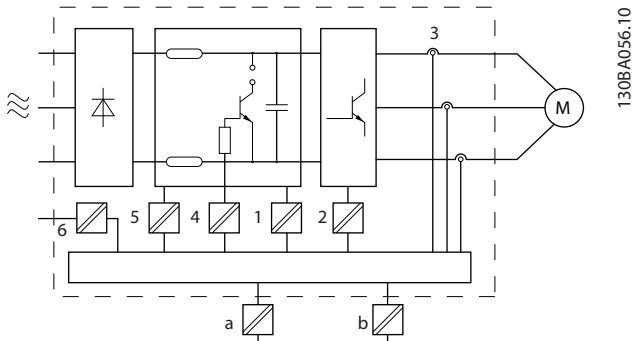

Illustration 2.21 Galvanic Isolation

The functional galvanic isolation (a and b on drawing) is for the 24 V back-up option and for the RS-485 standard bus interface.

### ⚠ WARNING

Touching the electrical parts could be fatal - even after the equipment has been disconnected from mains.

Also make sure that other voltage inputs have been disconnected, such as load sharing (linkage of DC intermediate circuit), as well as the motor connection for kinetic back-up.

Before touching any electrical parts, wait at least the amount of time indicated in *Table 1.3*.

Shorter time is allowed only if indicated on the nameplate for the specific unit.

### 2.8.1 Earth Leakage Current

Follow national and local codes regarding protective earthing of equipment with a leakage current > 3,5 mA. Frequency converter technology implies high frequency switching at high power. This will generate a leakage current in the earth connection. A fault current in the frequency converter at the output power terminals might contain a DC component which can charge the filter capacitors and cause a transient earth current. The earth leakage current is made up of several contributions and depends on various system configurations including RFI filtering, screened motor cables, and frequency converter power.

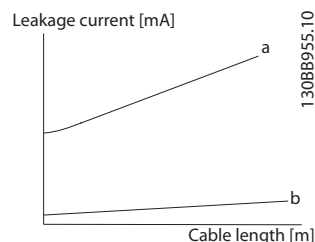

Illustration 2.22 Leakage Current Influenced by the Cable Length and Power Size

2

The leakage current also depends on the line distortion

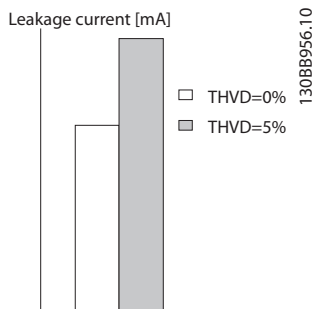

Illustration 2.23 Leakage Current Influenced by Line Distortion

**NOTE**

When a filter is used, remove the RFI screw (enclosure size J1 to J5) or turn off 14-50 RFI Filter (enclosure size J6 to J7) when charging the filter, to avoid that a high leakage current makes the RCD switch.

EN/IEC61800-5-1 (Power Drive System Product Standard) requires special care if the leakage current exceeds 3.5mA. Earth grounding must be reinforced in one of the following ways:

- Earth ground wire (terminal 95) of at least 10 mm<sup>2</sup>
- Two separate earth ground wires both complying with the dimensioning rules

See EN/IEC61800-5-1 and EN50178 for further information.

**Using RCDs**

Where residual current devices (RCDs), also known as earth leakage circuit breakers (ELCBs), are used, comply with the following:

Use RCDs of type B only which are capable of detecting AC and DC currents

Use RCDs with an inrush delay to prevent faults due to transient earth currents

Dimension RCDs according to the system configuration and environmental considerations

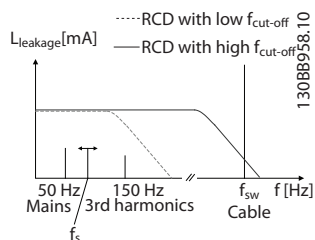

Illustration 2.24 Main Contributions to Leakage Current

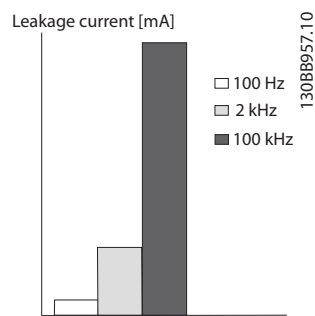

Illustration 2.25 Influence of Cut-off Frequency of the RCD on what is Responded to/Measured

See also RCD Application Note, MN90GX02.

2.9 Brake Functions

2.9.1 Mechanical Holding Brake

A mechanical holding brake mounted directly on the motor shaft normally performs static braking.

**NOTE**

When the holding brake is included in a safety chain: A frequency converter cannot provide a safe control of a mechanical brake. A redundancy circuitry for the brake control must be included in the total installation.

2.9.2 Dynamic Braking

Dynamic Brake established by:

- Resistor brake: A brake IGBT keep the overvoltage under a certain threshold by directing the brake energy from the motor to the connected brake resistor (2-10 Brake Function = [1] Resistor brake).
- AC brake: The brake energy is distributed in the motor by changing the loss conditions in the motor. The AC brake function cannot be used in applications with high cycling frequency since this will overheat the motor (2-10 Brake Function = [2] AC brake).
- DC brake: An over-modulated DC current added to the AC current works as an eddy current brake (2-10 Brake Function≠0 s).

2.9.3 Selection of Brake Resistor

To handle higher demands by generative braking, a brake resistor is necessary. Using a brake resistor ensures that the energy is absorbed in the brake resistor and not in the frequency converter. For more information, see the Brake Resistor Design Guide.

If the amount of kinetic energy transferred to the resistor in each braking period is not known, the average power can be calculated on the basis of the cycle time and braking time also called intermittent duty cycle. The resistor intermittent duty cycle is an indication of the duty cycle at which the resistor is active. *Illustration 2.26* shows a typical braking cycle.

**NOTE**

Motor suppliers often use S5 when stating the permissible load which is an expression of intermittent duty cycle.

The intermittent duty cycle for the resistor is calculated as follows:

$$\text{Duty cycle} = t_b/T$$

T = cycle time in seconds

t<sub>b</sub> is the braking time in seconds (of the cycle time)

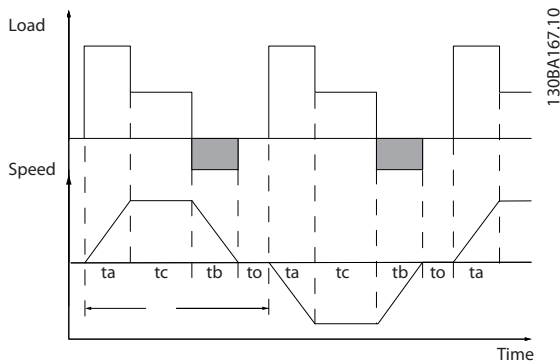

Illustration 2.26 Typical Braking Cycle

	HK37 - H75K
<b>380-480 V</b>	
<b>Cycle time (s)</b>	120
<b>Braking duty cycle at 100% torque</b>	Continuous
<b>Braking duty cycle at over torque (150/160%)</b>	40%

Table 2.12 Braking at High overload Torque Level

Danfoss offers brake resistors with duty cycle of 5%, 10% and 40%. If a 10% duty cycle is applied, the brake resistors are able to absorb brake power for 10% of the cycle time. The remaining 90% of the cycle time will be used on dissipating excess heat.

**NOTE**

Make sure the resistor is designed to handle the required braking time.

The max. permissible load on the brake resistor is stated as a peak power at a given intermittent duty cycle and can be calculated as:

The brake resistance is calculated as shown:

$R_{br}[\Omega] = \frac{U_{dc}^2}{P_{peak}}$
where
$P_{peak} = P_{motor} \times M_{br} [\%] \times \eta_{motor} \times \eta_{VLT}[W]$

Table 2.13 Brake Resistance

As can be seen, the brake resistance depends on the intermediate circuit voltage (U<sub>dc</sub>).

The brake function is settled in 4 areas of mains.

Size	Brake active	Warning before cut out	Cut out (trip)
FC 360 3 x 380-480 V	770 V	810 V	820 V

Table 2.14 Areas of Mains

**NOTE**

Check that the brake resistor can cope with a voltage of 410 V, 820 V, 850 V, 975 V or 1130 V - unless Danfoss brake resistors are used.

Danfoss recommends the brake resistance R<sub>rec</sub>, i.e. one that guarantees that the frequency converter is able to brake at the highest braking torque (M<sub>br</sub>(%)) of 160%. The formula can be written as:

$$R_{rec}[\Omega] = \frac{U_{dc}^2 \times 100}{P_{motor} \times M_{br}(\%) \times \eta_{VLT} \times \eta_{motor}}$$

η<sub>motor</sub> is typically at 0.90

η<sub>VLT</sub> is typically at 0.98

For 200 V, 480 V, 500 V and 600 V frequency converters, R<sub>rec</sub> at 160% braking torque is written as:

$$200V : R_{rec} = \frac{107780}{P_{motor}} [\Omega]$$

$$480V : R_{rec} = \frac{375300}{P_{motor}} [\Omega] \text{ 1)}$$

$$480V : R_{rec} = \frac{428914}{P_{motor}} [\Omega] \text{ 2)}$$

$$500V : R_{rec} = \frac{464923}{P_{motor}} [\Omega]$$

$$600V : R_{rec} = \frac{630137}{P_{motor}} [\Omega]$$

$$690V : R_{rec} = \frac{832664}{P_{motor}} [\Omega]$$

1) For frequency converters ≤ 7.5 kW shaft output

2) For frequency converters 11-75 kW shaft output

**NOTE**

The resistor brake circuit resistance selected should not be higher than that recommended by Danfoss. If a brake resistor with a higher ohmic value is selected, the 160% braking torque may not be achieved because there is a risk that the frequency converter cuts out for safety reasons.

**NOTE**

If a short circuit in the brake transistor occurs, power dissipation in the brake resistor is only prevented by using a mains switch or contactor to disconnect the mains for the frequency converter. (The contactor can be controlled by the frequency converter).

**NOTE**

Do not touch the brake resistor as it can get very hot while/after braking. The brake resistor must be placed in a secure environment to avoid fire risk

**CAUTION**

D-F size frequency converters contain more than one brake chopper. Consequently, use one brake resistor per brake chopper for those frame sizes.

2.9.4 Control with Brake Function

The brake is protected against short-circuiting of the brake resistor, and the brake transistor is monitored to ensure that short-circuiting of the transistor is detected. A relay/digital output can be used for protecting the brake resistor against overloading in connection with a fault in the frequency converter.

In addition, the brake makes it possible to read out the momentary power and the mean power for the latest 120 seconds. The brake can also monitor the power energizing and make sure it does not exceed a limit selected in 2-12 Brake Power Limit (kW). In 2-13 Brake Power Monitoring, select the function to carry out when the power transmitted to the brake resistor exceeds the limit set in 2-12 Brake Power Limit (kW).

**NOTE**

Monitoring the brake power is not a safety function; a thermal switch is required for that purpose. The brake resistor circuit is not earth leakage protected.

Over voltage control (OVC) (exclusive brake resistor) can be selected as an alternative brake function in 2-17 Over-voltage Control. This function is active for all units. The function ensures that a trip can be avoided if the DC link voltage increases. This is done by increasing the output frequency to limit the voltage from the DC link. It is a very useful function, e.g. if the ramp-down time is too short

since tripping of the frequency converter is avoided. In this situation the ramp-down time is extended.

**NOTE**

OVC can not be activated when running a PM motor (when 1-10 Motor Construction is set to [1] PM non salient SPM).

2.10 Smart Logic Controller

Smart Logic Control (SLC) is essentially a sequence of user defined actions (see 13-52 SL Controller Action [x]) executed by the SLC when the associated user defined event (see 13-51 SL Controller Event [x]) is evaluated as TRUE by the SLC.

The condition for an event can be a particular status or that the output from a Logic Rule or a Comparator Operand becomes TRUE. That will lead to an associated action as illustrated:

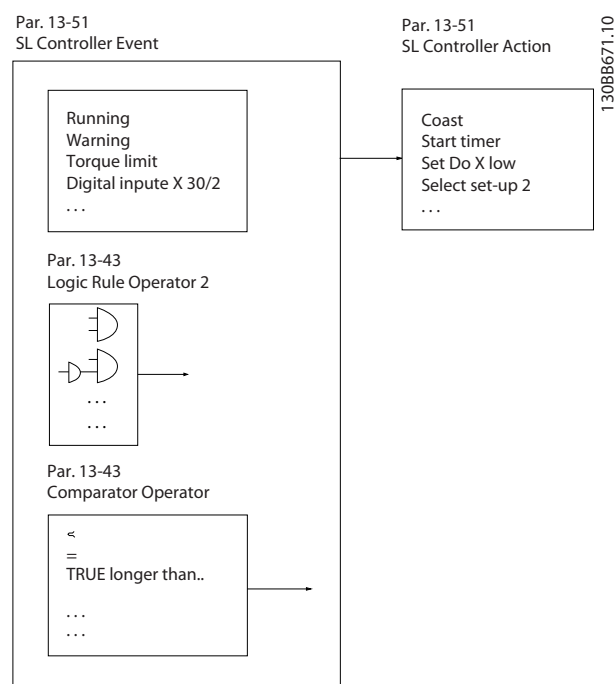

Illustration 2.27 Associated Action

Events and actions are each numbered and linked together in pairs (states). This means that when event [0] is fulfilled (attains the value TRUE), action [0] is executed. After this, the conditions of event [1] will be evaluated and if evaluated TRUE, action [1] will be executed and so on. Only one event will be evaluated at any time. If an event is evaluated as FALSE, nothing happens (in the SLC) during the current scan interval and no other events will be evaluated. This means that when the SLC starts, it evaluates event [0] (and only event [0]) each scan interval. Only when event [0] is evaluated TRUE, will the SLC

execute *action* [0] and start evaluating *event* [1]. It is possible to programme from 1 to 20 *events* and *actions*. When the last *event/action* has been executed, the sequence starts over again from *event* [0]/*action* [0]. *Illustration 2.28* shows an example with three *event/actions*:

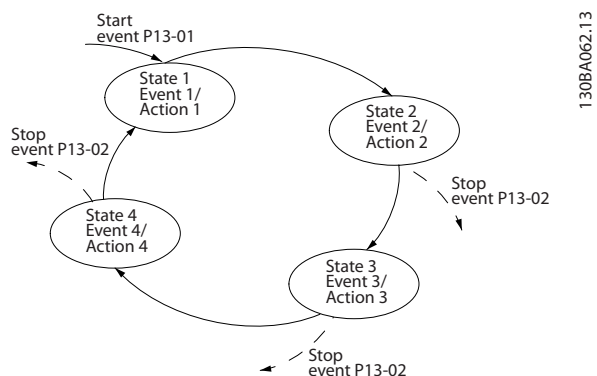

Illustration 2.28 Sequence with Three Event/Actions

**Comparators**

Comparators are used for comparing continuous variables (i.e. output frequency, output current, analog input etc.) to fixed preset values.

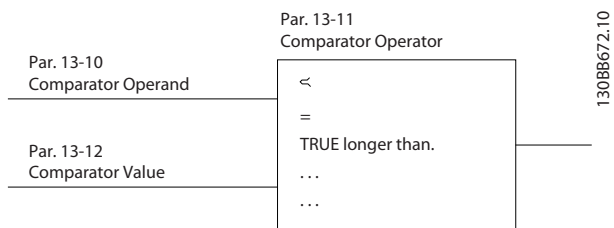

Illustration 2.29 Comparators

**Logic Rules**

Combine up to three boolean inputs (TRUE/FALSE inputs) from timers, comparators, digital inputs, status bits and events using the logical operators AND, OR, and NOT.

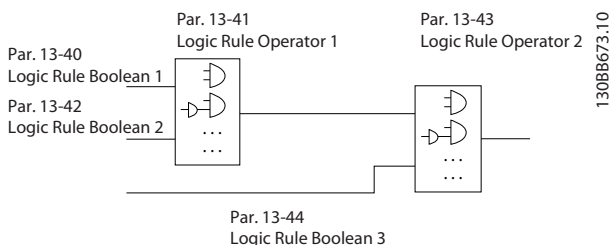

Illustration 2.30 Logic Rules

**2.11 Extreme Running Conditions**

**Short Circuit (Motor Phase – Phase)**

The frequency converter is protected against short circuits by means of current measurement in each of the three motor phases or in the DC link. A short circuit between two output phases will cause an overcurrent in the inverter. The inverter will be turned off individually when the short circuit current exceeds the permitted value (Alarm 16 Trip Lock).

To protect the frequency converter against a short circuit at the load sharing and brake outputs, see the design guidelines.

**Switching on the Output**

Switching on the output between the motor and the frequency converter is fully permitted, and does not damage the frequency converter. However, fault messages may appear.

**Motor-generated Over-voltage**

The voltage in the intermediate circuit is increased when the motor acts as a generator. This occurs in following cases:

1. The load drives the motor (at constant output frequency from the frequency converter), i.e. the load generates energy.
2. During deceleration ("ramp-down") if the moment of inertia is high, the friction is low and the ramp-down time is too short for the energy to be dissipated as a loss in the frequency converter, the motor and the installation.
3. Incorrect slip compensation setting may cause higher DC link voltage.

The control unit may attempt to correct the ramp if possible (2-17 *Over-voltage Control*).

The inverter turns off to protect the transistors and the intermediate circuit capacitors when a certain voltage level is reached.

See 2-10 *Brake Function* and 2-17 *Over-voltage Control* to select the method used for controlling the intermediate circuit voltage level.

**Mains Drop-out**

During a mains drop-out, the frequency converter keeps running until the intermediate circuit voltage drops below the minimum stop level, which is typically 15% below the frequency converter's lowest rated supply voltage. The mains voltage before the drop-out and the motor load determines how long it takes for the inverter to coast.

**Static Overload in WVC<sup>plus</sup> mode**

When the frequency converter is overloaded (the torque limit in 4-16 *Torque Limit Motor Mode*/4-17 *Torque Limit Generator Mode* is reached), the controls reduces the output frequency to reduce the load.

If the overload is excessive, a current may occur that makes the frequency converter cut out after approx. 5-10 s.

Operation within the torque limit is limited in time (0-60 s.) in 14-25 *Trip Delay at Torque Limit*.

**2.11.1 Motor Thermal Protection**

To protect the application from serious damages VLT® AutomationDrive offers several dedicated features.

**Torque Limit**

The Torque limit feature the motor is protected for being overloaded independent of the speed. Torque limit is controlled in 4-16 *Torque Limit Motor Mode* and or 4-17 *Torque Limit Generator Mode* and the time before the torque limit warning shall trip is controlled in 14-25 *Trip Delay at Torque Limit*.

**Current Limit**

The current limit is controlled in 4-18 *Current Limit* and the time before the current limit warning shall trip is controlled in 14-24 *Trip Delay at Current Limit*.

**Min Speed Limit**

(4-12 *Motor Speed Low Limit [Hz]*) limit the operating speed range to for instance between 30 and 50/60 Hz.

**Max Speed Limit**

(4-14 *Motor Speed High Limit [Hz]* or 4-19 *Max Output Frequency*) limit the max output speed the drive can provide

**ETR (Electronic Thermal relay)**

The frequency converter ETR function measures actual current, speed and time to calculate motor temperature and protect the motor from being overheated (Warning or trip). An external thermistor input is also available. ETR is an electronic feature that simulates a bimetal relay based on internal measurements. The characteristic is shown in *Illustration 2.31*

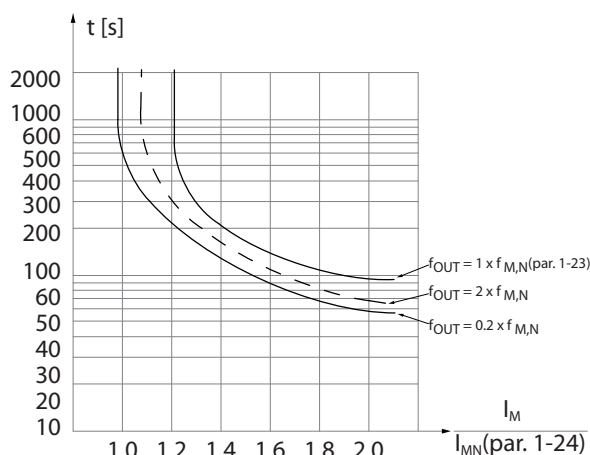

175ZA052.12

**Illustration 2.31 ETR**

The X-axis shows the ratio between  $I_{motor}$  and  $I_{motor}$  nominal. The Y- axis shows the time in seconds before the ETR cut of and trips the drive. The curves show the characteristic nominal speed, at twice the nominal speed and at 0,2 x the nominal speed.

At lower speed the ETR cuts of at lower heat due to less cooling of the motor. In that way the motor are protected from being over heated even at low speed. The ETR feature is calculating the motor temperature based on actual current and speed. The calculated temperature is visible as a read out parameter in 16-18 *Motor Thermal*.



## 3 RS-485 Installation and Set-up

### 3.1.1 Overview

RS-485 is a two-wire bus interface compatible with multi-drop network topology, that is, nodes can be connected as a bus, or via drop cables from a common trunk line. A total of 32 nodes can be connected to one network segment.

Repeaters divide network segments.

#### NOTE

Each repeater functions as a node within the segment in which it is installed. Each node connected within a given network must have a unique node address, across all segments.

Terminate each segment at both ends, using either the termination switch (S801) of the frequency converters or a biased termination resistor network. Always use screened twisted pair (STP) cable for bus cabling, and always follow good common installation practice.

Low-impedance earth connection of the screen at every node is important, including at high frequencies. Thus, connect a large surface of the screen to earth, for example with a cable clamp or a conductive cable gland. It may be necessary to apply potential-equalizing cables to maintain the same earth potential throughout the network - particularly in installations with long cables.

To prevent impedance mismatch, always use the same type of cable throughout the entire network. When connecting a motor to the frequency converter, always use screened motor cable.

<b>Cable</b>	<b>Screened twisted pair (STP)</b>
Impedance	120 Ω
Cable length	Max. 1200 m (including drop lines)
	Max. 500 m station-to-station

Table 3.1 Cable

### 3.1.2 Network Connection

Connect the frequency converter to the RS-485 network as follows (see also *Illustration 3.1*):

1. Connect signal wires to terminal 68 (P+) and terminal 69 (N-) on the main control board of the frequency converter.
2. Connect the cable screen to the cable clamps.

#### NOTE

Screened, twisted-pair cables are recommended in order to reduce noise between conductors.

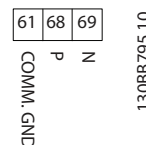

Illustration 3.1 Network Connection

### 3.1.3 Frequency Converter Hardware Set-up

Use the terminator dip switch on the main control board of the frequency converter to terminate the RS-485 bus.

The factory setting for the dip switch is OFF.

### 3.1.4 Frequency Converter Parameter Settings for Modbus Communication

Define the RS-485 Communication Set-up

Parameter	Function
8-30 Protocol	Select the application protocol to run on the RS-485 interface
8-31 Address	Set the node address. <b>NOTE</b> The address range depends on the protocol selected in <i>8-30 Protocol</i>
8-32 Baud Rate	Set the baud rate. <b>NOTE</b> The default baud rate depends on the protocol selected in <i>8-30 Protocol</i>

Parameter	Function
8-33 Parity / Stop Bits	Set the parity and number of stop bits. <b>NOTE</b> The default selection depends on the protocol selected in <i>8-30 Protocol</i>
8-35 Minimum Response Delay	Specify a minimum delay time between receiving a request and transmitting a response. This function is for overcoming modem turnaround delays.
8-36 Maximum Response Delay	Specify a maximum delay time between transmitting a request and receiving a response.
8-37 Maximum Inter-char delay	If transmission is interrupted, specify a maximum delay time between two received bytes to ensure time-out.

**Table 3.2 Modbus Communication Parameter Settings**

### 3.1.5 EMC Precautions

To achieve interference-free operation of the RS-485 network, Danfoss recommends the following EMC precautions.

Relevant national and local regulations, for example regarding protective earth connection, must be observed. To avoid coupling of high frequency noise between the cables, the RS-485 communication cable must be kept away from motor and brake resistor cables. Normally a distance of 200 mm (8 inches) is sufficient, but Danfoss recommends keeping the greatest possible distance between the cables. Especially where cables run in parallel over long distances. When crossing is unavoidable, the RS-485 cable must cross motor and brake resistor cables at an angle of 90°.

## 3.2 FC Protocol Overview

The FC protocol, also referred to as FC bus or Standard bus, is the Danfoss standard fieldbus. It defines an access technique according to the master-slave principle for communications via a serial bus.

One master and a maximum of 126 slaves can be connected to the bus. The master selects the individual slaves via an address character in the telegram. A slave itself can never transmit without first being requested to do so, and direct message transfer between the individual slaves is not possible. Communications occur in the half-duplex mode.

The master function cannot be transferred to another node (single-master system).

The physical layer is RS-485, thus utilizing the RS-485 port built into the frequency converter. The FC protocol supports different telegram formats:

- A short format of 8 bytes for process data.
- A long format of 16 bytes that also includes a parameter channel.
- A format used for texts.

### 3.2.1 FC with Modbus RTU

The FC protocol provides access to the Control Word and Bus Reference of the frequency converter.

The Control Word allows the Modbus master to control several important functions of the frequency converter.

- Start
- Stop of the frequency converter in various ways:
  - Coast stop
  - Quick stop
  - DC Brake stop
  - Normal (ramp) stop
- Reset after a fault trip
- Run at various preset speeds
- Run in reverse
- Change of the active set-up
- Control of the 2 relays built into the frequency converter

The Bus Reference is commonly used for speed control. It is also possible to access the parameters, read their values, and where possible, write values to them. This permits a range of control options, including controlling the setpoint

of the frequency converter when its internal PI controller is used.

### 3.3 Network Configuration

#### 3.3.1 Frequency Converter Set-up

Set the following parameters to enable the FC protocol for the frequency converter.

Parameter	Setting
8-30 Protocol	FC
8-31 Address	1-126
8-32 Baud Rate	2400-115200
8-33 Parity / Stop Bits	Even parity, 1 stop bit (default)

**Table 3.3 Network Configuration Parameters**

### 3.4 FC Protocol Message Framing Structure

#### 3.4.1 Content of a Character (byte)

Each character transferred begins with a start bit. Then 8 data bits are transferred, corresponding to a byte. Each character is secured via a parity bit. This bit is set at "1" when it reaches parity. Parity is when there is an equal number of 1s in the 8 data bits and the parity bit in total. A stop bit completes a character, thus consisting of 11 bits in all.



**Illustration 3.2 Content of a Character**

#### 3.4.2 Telegram Structure

Each telegram has the following structure:

1. Start character (STX)=02 Hex
2. A byte denoting the telegram length (LGE)
3. A byte denoting the frequency converter address (ADR)

A number of data bytes (variable, depending on the type of telegram) follows.

A data control byte (BCC) completes the telegram.

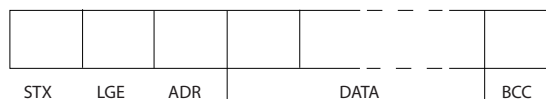

**Illustration 3.3 Telegram Structure**

#### 3.4.3 Telegram Length (LGE)

The telegram length is the number of data bytes plus the address byte ADR and the data control byte BCC.

4 data bytes	LGE=4+1+1=6 bytes
12 data bytes	LGE=12+1+1=14 bytes
Telegrams containing texts	10 <sup>1)</sup> +n bytes

**Table 3.4 Length of Telegrams**

<sup>1)</sup> The 10 represents the fixed characters, while the "n" is variable (depending on the length of the text).

#### 3.4.4 Frequency Converter Address (ADR)

##### Address format 1-126

- Bit 7=1 (address format 1-126 active)
- Bit 0-6=frequency converter address 1-126
- Bit 0-6=0 Broadcast

The slave returns the address byte unchanged to the master in the response telegram.

#### 3.4.5 Data Control Byte (BCC)

The checksum is calculated as an XOR-function. Before the first byte in the telegram is received, the Calculated Checksum is 0.

#### 3.4.6 The Data Field

The structure of data blocks depends on the type of telegram. There are three telegram types, and the type applies for both control telegrams (master⇒slave) and response telegrams (slave⇒master).

The 3 types of telegram are:

##### Process block (PCD)

The PCD is made up of a data block of 4 bytes (2 words) and contains:

- Control word and reference value (from master to slave)
- Status word and present output frequency (from slave to master)

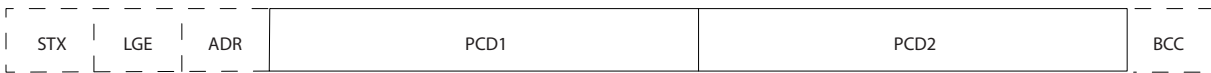

130BA269.10

Illustration 3.4 Process Block

3

Parameter block

The parameter block is used to transfer parameters between master and slave. The data block is made up of 12 bytes (6 words) and also contains the process block.

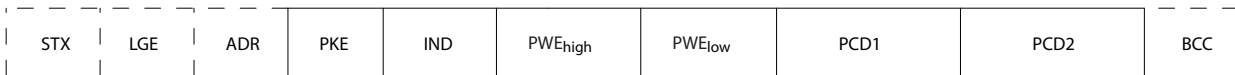

130BA271.10

Illustration 3.5 Parameter Block

Text block

The text block is used to read or write texts via the data block.

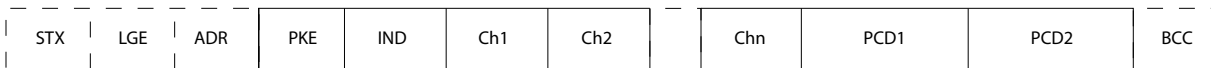

130BA270.10

Illustration 3.6 Text Block

3.4.7 The PKE Field

The PKE field contains two subfields: Parameter command and response (AK) and Parameter number (PNU):

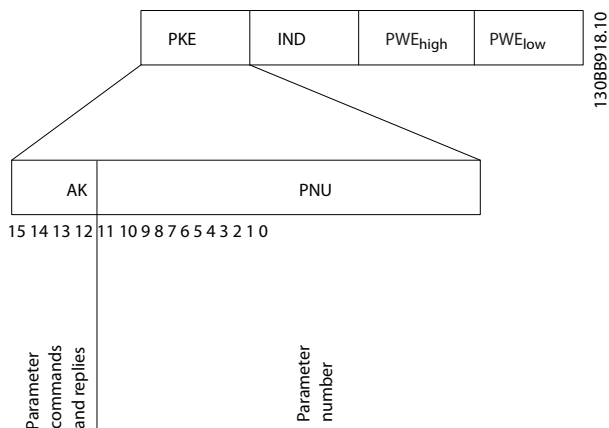

130B8918.10

Illustration 3.7 PKE Field

Bits no. 12-15 transfer parameter commands from master to slave and return processed slave responses to the master.

Parameter commands master → slave				
Bit no.				Parameter command
15	14	13	12	
0	0	0	0	No command
0	0	0	1	Read parameter value
0	0	1	0	Write parameter value in RAM (word)
0	0	1	1	Write parameter value in RAM (double word)
1	1	0	1	Write parameter value in RAM and EEPROM (double word)
1	1	1	0	Write parameter value in RAM and EEPROM (word)
1	1	1	1	Read text

Table 3.5 Parameter Commands

Response slave → master				
Bit no.				Response
15	14	13	12	
0	0	0	0	No response
0	0	0	1	Parameter value transferred (word)
0	0	1	0	Parameter value transferred (double word)
0	1	1	1	Command cannot be performed
1	1	1	1	text transferred

Table 3.6 Response

If the command cannot be performed, the slave sends this response:

0111 Command cannot be performed

- and issues the following fault report in the parameter value:

Error code	FC+ Specification
0	Illegal Parameter Number
1	Parameter cannot be changed.
2	Upper or lower limit exceeded
3	Subindex corrupted
4	No Array
5	Wrong Data Type
6	Not used
7	Not used
9	Description element not available
11	No parameter write access
15	No text available
17	Not while Running
18	Other error
100	
>100	
130	No bus access for this parameter
131	Write to factory set-up not possible
132	No LCP access
252	Unknown viewer
253	Request not supported
254	Unknown attribute
255	No error

Table 3.7 Slave Report

### 3.4.8 Parameter Number (PNU)

Bits no. 0-11 transfer parameter numbers. The function of the relevant parameter is defined in the parameter description in the VLT® AutomationDrive FC 360 Programming Guide.

### 3.4.9 Index (IND)

The index is used together with the parameter number to read/write-access parameters with an index, for example, *15-30 Alarm Log: Error Code*. The index consists of 2 bytes; a low byte, and a high byte.

Only the low byte is used as an index.

### 3.4.10 Parameter Value (PWE)

The parameter value block consists of 2 words (4 bytes), and the value depends on the defined command (AK). The master prompts for a parameter value when the PWE block contains no value. To change a parameter value (write),

write the new value in the PWE block and send from the master to the slave.

When a slave responds to a parameter request (read command), the present parameter value in the PWE block is transferred and returned to the master. If a parameter contains several data options, e.g. *0-01 Language*, select the data value by entering the value in the PWE block. Serial communication is only capable of reading parameters containing data type 9 (text string).

*15-40 FC Type* to *15-53 Power Card Serial Number* contain data type 9.

For example, read the unit size and mains voltage range in *15-40 FC Type*. When a text string is transferred (read), the length of the telegram is variable, and the texts are of different lengths. The telegram length is defined in the second byte of the telegram (LGE). When using text transfer, the index character indicates whether it is a read or a write command.

To read a text via the PWE block, set the parameter command (AK) to 'F' Hex. The index character high-byte must be "4".

### 3.4.11 Data Types Supported by the Frequency Converter

Unsigned means that there is no operational sign in the telegram.

Data types	Description
3	Integer 16
4	Integer 32
5	Unsigned 8
6	Unsigned 16
7	Unsigned 32
9	Text string

Table 3.8 Data Types

### 3.4.12 Conversion

The various attributes of each parameter are displayed in the chapter *Parameter Lists* in the *Programming Guide*. Parameter values are transferred as whole numbers only. Conversion factors are therefore used to transfer decimals.

*4-12 Motor Speed Low Limit [Hz]* has a conversion factor of 0.1.

To preset the minimum frequency to 10 Hz, transfer the value 100. A conversion factor of 0.1 means that the value transferred is multiplied by 0.1. The value 100 is thus perceived as 10.0.

Conversion index	Conversion factor
74	0.1
2	100
1	10
0	1
-1	0.1
-2	0.01
-3	0.001
-4	0.0001
-5	0.00001

Table 3.9 Conversion

### 3.4.13 Process Words (PCD)

The block of process words is divided into two blocks of 16 bits, which always occur in the defined sequence.

PCD 1	PCD 2
Control telegram (master⇒slave Control word)	Reference-value
Control telegram (slave⇒master) Status word	Present output frequency

Table 3.10 Process Words (PCD)

## 3.5 Examples

### 3.5.1 Writing a Parameter Value

Change 4-14 Motor Speed High Limit [Hz] to 100 Hz. Write the data in EEPROM.

PKE=E19E Hex - Write single word in 4-14 Motor Speed High Limit [Hz]:

IND=0000 Hex

PWEHIGH=0000 Hex

PWELOW=03E8 Hex

Data value 1000, corresponding to 100 Hz, see 3.4.12 Conversion.

The telegram looks like this:

E19E	H	0000	H	0000	H	03E8	H
PKE		IND		PWE <sub>high</sub>		PWE <sub>low</sub>	

Illustration 3.8 Telegram

130BA092.10

## NOTE

4-14 Motor Speed High Limit [Hz] is a single word, and the parameter command for write in EEPROM is "E". Parameter 4-14 is 19E in hexadecimal.

The response from the slave to the master is:

119E	H	0000	H	0000	H	03E8	H
PKE		IND		PWE <sub>high</sub>		PWE <sub>low</sub>	

Illustration 3.9 Response from Master

130BA093.10

### 3.5.2 Reading a Parameter Value

Read the value in 3-41 Ramp 1 Ramp up Time

PKE=1155 Hex - Read parameter value in 3-41 Ramp 1 Ramp up Time  
 IND=0000 Hex  
 PWEHIGH=0000 Hex  
 PWELOW=0000 Hex

1155	H	0000	H	0000	H	0000	H
PKE		IND		PWE <sub>high</sub>		PWE <sub>low</sub>	

Illustration 3.10 Telegram

130BA094.10

If the value in 3-41 Ramp 1 Ramp up Time is 10 s, the response from the slave to the master is:

1155	H	0000	H	0000	H	03E8	H
PKE		IND		PWE <sub>high</sub>		PWE <sub>low</sub>	

Illustration 3.11 Response

130BA267.10

3E8 Hex corresponds to 1000 decimal. The conversion index for 3-41 Ramp 1 Ramp up Time is -2, that is, 0.01. 3-41 Ramp 1 Ramp up Time is of the type Unsigned 32.

## 3.6 Modbus RTU Overview

### 3.6.1 Assumptions

Danfoss assumes that the installed controller supports the interfaces in this document, and strictly observe all requirements and limitations stipulated in the controller and frequency converter.

### 3.6.2 What the User Should Already Know

The Modbus RTU (Remote Terminal Unit) is designed to communicate with any controller that supports the interfaces defined in this document. It is assumed that the user has full knowledge of the capabilities and limitations of the controller.

### 3.6.3 Modbus RTU Overview

Regardless of the type of physical communication networks, the Modbus RTU Overview describes the process a controller uses to request access to another device. This process includes how the Modbus RTU responds to requests from another device, and how errors are detected and reported. It also establishes a common format for the layout and contents of message fields.

During communications over a Modbus RTU network, the protocol determines:

- How each controller learns its device address
- Recognizes a message addressed to it
- Determines which actions to take
- Extracts any data or other information contained in the message

If a reply is required, the controller constructs the reply message and sends it.

Controllers communicate using a master-slave technique in which only one device (the master) can initiate transactions (called queries). The other devices (slaves) respond by supplying the requested data to the master, or by taking the action requested in the query.

The master can address individual slaves, or can initiate a broadcast message to all slaves. Slaves return a message (called a response) to queries that are addressed to them individually. No responses are returned to broadcast queries from the master. The Modbus RTU protocol establishes the format for the master's query by placing into it the device (or broadcast) address, a function code defining the requested action, any data to be sent, and an error-checking field. The slave's response message is also constructed using Modbus protocol. It contains fields confirming the action taken, any data to be returned, and an error-checking field. If an error occurs in receipt of the message, or if the slave is unable to perform the requested action, the slave constructs an error message, and send it in response, or a time-out occurs.

### 3.6.4 Frequency Converter with Modbus RTU

The frequency converter communicates in Modbus RTU format over the built-in RS-485 interface. Modbus RTU provides access to the control word and bus reference of the frequency converter.

The control word allows the modbus master to control several important functions of the frequency converter:

- Start
- Stop of the frequency converter in various ways:
  - Coast stop
  - Quick stop
  - DC Brake stop
  - Normal (ramp) stop
- Reset after a fault trip
- Run at a variety of preset speeds
- Run in reverse
- Change the active set-up
- Control the frequency converter's built-in relay

The bus reference is commonly used for speed control. It is also possible to access the parameters, read their values, and where possible, write values to them. This permits a range of control options, including controlling the setpoint of the frequency converter when its internal PI controller is used.

## 3.7 Network Configuration

To enable Modbus RTU on the frequency converter, set the following parameters:

Parameter	Setting
8-30 Protocol	Modbus RTU
8-31 Address	1-247
8-32 Baud Rate	2400-115200
8-33 Parity/Stop Bits	Even parity, 1 stop bit (default)

Table 3.11 Network Configuration

## 3.8 Modbus RTU Message Framing Structure

### 3.8.1 Frequency Converter with Modbus RTU

The controllers are set up to communicate on the Modbus network using RTU (Remote Terminal Unit) mode, with each byte in a message containing 2 4-bit hexadecimal characters. The format for each byte is shown in Table 3.12.

Start bit	Data byte							Stop/parity	Stop

**Table 3.12 Format for Each Byte**

Coding System	8-bit binary, hexadecimal 0-9, A-F. 2 hexadecimal characters contained in each 8-bit field of the message
Bits Per Byte	1 start bit 8 data bits, least significant bit sent first 1 bit for even/odd parity; no bit for no parity 1 stop bit if parity is used; 2 bits if no parity
Error Check Field	Cyclical Redundancy Check (CRC)

### 3.8.2 Modbus RTU Message Structure

The transmitting device places a Modbus RTU message into a frame with a known beginning and ending point. This allows receiving devices to begin at the start of the message, read the address portion, determine which device is addressed (or all devices, if the message is broadcast), and to recognise when the message is completed. Partial messages are detected and errors set as a result. Characters for transmission must be in hexadecimal 00 to FF format in each field. The frequency converter continuously monitors the network bus, also during 'silent' intervals. When the first field (the address field) is received, each frequency converter or device decodes it to determine which device is being addressed. Modbus RTU messages addressed to zero are broadcast messages. No response is permitted for broadcast messages. A typical message frame is shown in *Table 3.14*.

Start	Address	Function	Data	CRC check	End
T1-T2-T3-T4	8 bits	8 bits	N x 8 bits	16 bits	T1-T2-T3-T4

**Table 3.13 Typical Modbus RTU Message Structure**

### 3.8.3 Start/Stop Field

Messages start with a silent period of at least 3.5 character intervals. This is implemented as a multiple of character intervals at the selected network baud rate (shown as Start T1-T2-T3-T4). The first field to be transmitted is the device address. Following the last transmitted character, a similar period of at least 3.5 character intervals marks the end of the message. A new message can begin after this period. The entire message frame must be transmitted as a continuous stream. If a silent period of more than 1.5 character intervals occurs before completion of the frame, the receiving device flushes the incomplete message and assumes that the next byte is the address field of a new message. Similarly, if a new message begins before to 3.5

character intervals after a previous message, the receiving device will consider it a continuation of the previous message. This causes a time-out (no response from the slave), since the value in the final CRC field is not valid for the combined messages.

### 3.8.4 Address Field

The address field of a message frame contains 8 bits. Valid slave device addresses are in the range of 0-247 decimal. The individual slave devices are assigned addresses in the range of 1-247. (0 is reserved for broadcast mode, which all slaves recognize.) A master addresses a slave by placing the slave address in the address field of the message. When the slave sends its response, it places its own address in this address field to let the master know which slave is responding.

### 3.8.5 Function Field

The function field of a message frame contains 8 bits. Valid codes are in the range of 1-FF. Function fields are used to send messages between master and slave. When a message is sent from a master to a slave device, the function code field tells the slave what kind of action to perform. When the slave responds to the master, it uses the function code field to indicate either a normal (error-free) response, or that some kind of error occurred (called an exception response). For a normal response, the slave simply echoes the original function code. For an exception response, the slave returns a code that is equivalent to the original function code with its most significant bit set to logic 1. In addition, the slave places a unique code into the data field of the response message. This tells the master what kind of error occurred, or the reason for the exception. Also refer to *3.8.10 Function Codes Supported by Modbus RTU* and *3.8.11 Modbus Exception Codes*

### 3.8.6 Data Field

The data field is constructed using sets of two hexadecimal digits, in the range of 00 to FF hexadecimal. These are made up of one RTU character. The data field of messages sent from a master to slave device contains additional information which the slave must use to take the action defined by the function code. This can include items such as coil or register addresses, the quantity of items to be handled, and the count of actual data bytes in the field.

### 3.8.7 CRC Check Field

Messages include an error-checking field, operating based on a Cyclical Redundancy Check (CRC) method. The CRC field checks the contents of the entire message. It is applied regardless of any parity check method used for the individual characters of the message. The CRC value is



calculated by the transmitting device, which appends the CRC as the last field in the message. The receiving device recalculates a CRC during receipt of the message and compares the calculated value to the actual value received in the CRC field. If the two values are unequal, a bus time-out results. The error-checking field contains a 16-bit binary value implemented as two 8-bit bytes. When this is done, the low-order byte of the field is appended first, followed by the high-order byte. The CRC high-order byte is the last byte sent in the message.

### 3.8.8 Coil Register Addressing

In Modbus, all data are organized in coils and holding registers. Coils hold a single bit, whereas holding registers hold a 2-byte word (that is, 16 bits). All data addresses in Modbus messages are referenced to zero. The first occurrence of a data item is addressed as item number zero. For example: The coil known as 'coil 1' in a programmable controller is addressed as coil 0000 in the data address field of a Modbus message. Coil 127 decimal is addressed as coil 007EHEX (126 decimal).

Holding register 40001 is addressed as register 0000 in the data address field of the message. The function code field already specifies a 'holding register' operation. Therefore, the '4XXXX' reference is implicit. Holding register 40108 is addressed as register 006BHEX (107 decimal).

Coil Number	Description	Signal Direction
1-16	Frequency converter control word (see Table 3.16)	Master to slave
17-32	Frequency converter speed or set-point reference Range 0x0-0xFFFF (-200% ... -200%)	Master to slave
33-48	Frequency converter status word (see Table 3.16 and Table 3.17)	Slave to master
49-64	Open loop mode: Frequency converter output frequency Closed loop mode: Frequency converter feedback signal	Slave to master
65	Parameter write control (master to slave)	Master to slave
	0= Parameter changes are written to the RAM of the frequency converter	
	1= Parameter changes are written to the RAM and EEPROM of the frequency converter.	
66-65536	Reserved	

Table 3.14 Coil Register

Coil	0	1
01	Preset reference LSB	
02	Preset reference MSB	
03	DC brake	No DC brake
04	Coast stop	No coast stop
05	Quick stop	No quick stop
06	Freeze freq.	No freeze freq.
07	Ramp stop	Start
08	No reset	Reset
09	No jog	Jog
10	Ramp 1	Ramp 2
11	Data not valid	Data valid
12	Relay 1 off	Relay 1 on
13	Relay 2 off	Relay 2 on
14	Set up LSB	
15		
16	No reversing	Reversing

Table 3.15 Frequency Converter Control Word (FC Profile)

Coil	0	1
33	Control not ready	Control ready
34	Frequency converter not ready	Frequency converter ready
35	Coasting stop	Safety closed
36	No alarm	Alarm
37	Not used	Not used
38	Not used	Not used
39	Not used	Not used
40	No warning	Warning
41	Not at reference	At reference
42	Hand mode	Auto mode
43	Out of freq. range	In frequency range
44	Stopped	Running
45	Not used	Not used
46	No voltage warning	Voltage warning
47	Not in current limit	Current limit
48	No thermal warning	Thermal warning

Table 3.16 Frequency Converter Status Word (FC Profile)

Bus adress	Bus register <sup>1</sup>	PLC Register	Content	Access	Description
0	1	40001	Reserved		Reserved for Legacy Drives VLT 5000 and VLT 2800
1	2	40002	Reserved		Reserved for Legacy Drives VLT 5000 and VLT 2800
2	3	40003	Reserved		Reserved for Legacy Drives VLT 5000 and VLT 2800
3	4	40004	Free		
4	5	40005	Free		
5	6	40006	Modbus conf	Read/Write	TCP only. Reserved for Modbus TCP (p12-28 and 12-29 - store in Eeprom etc.)
6	7	40007	Last error code	Read only	Error code recieved from parameter database, refer to WHAT 38295 for details
7	8	40008	Last error register	Read only	Address of register with which last error occurred, refer to WHAT 38296 for details
8	9	40009	Index pointer	Read/Write	Sub index of parameter to be accessed. Refer to WHAT 38297 for details
9	10	40010	FC par. 0-01	Dependent on parameter access	Parameter 0-01 (Modbus Register=10 parameter number 20 bytes space reserved pr parameter in Modbus Map
19	20	40020	FC par. 0-02	Dependent on parameter access	Parameter 0-02 20 bytes space reserved pr parameter in Modbus Map
29	30	40030	FC par. xx-xx	Dependent on parameter access	Parameter 0-03 20 bytes space reserved pr parameter in Modbus Map

**Table 3.17 Adress/Registers**

<sup>1)</sup> Value written in Modbus RTU telegram must be one or less than register number. E.g. Read Modbus Register 1 by writing value 0 in telegram.

### 3.8.9 How to Control the Frequency Converter

This section describes codes which can be used in the function and data fields of a Modbus RTU message.

#### 3.8.10 Function Codes Supported by Modbus RTU

Modbus RTU supports use of the following function codes in the function field of a message.

Function	Function Code
Read coils	1 hex
Read holding registers	3 hex
Write single coil	5 hex
Write single register	6 hex
Write multiple coils	F hex
Write multiple registers	10 hex
Get comm. event counter	B hex
Report slave ID	11 hex

**Table 3.18 Function Codes**

Function	Function Code	Sub-function code	Sub-function
Diagnostics	8	1	Restart communication
		2	Return diagnostic register
		10	Clear counters and diagnostic register
		11	Return bus message count
		12	Return bus communication error count
		13	Return bus exception error count
		14	Return slave message count

**Table 3.19 Function Codes**

### 3.8.11 Modbus Exception Codes

For a full explanation of the structure of an exception code response, refer to 3.8.5 *Function Field*.

Code	Name	Meaning
1	Illegal function	The function code received in the query is not an allowable action for the server (or slave). This may be because the function code is only applicable to newer devices, and was not implemented in the unit selected. It could also indicate that the server (or slave) is in the wrong state to process a request of this type, for example because it is not configured and is being asked to return register values.
2	Illegal data address	The data address received in the query is not an allowable address for the server (or slave). More specifically, the combination of reference number and transfer length is invalid. For a controller with 100 registers, a request with offset 96 and length 4 would succeed, a request with offset 96 and length 5 generates exception 02.
3	Illegal data value	A value contained in the query data field is not an allowable value for server (or slave). This indicates a fault in the structure of the remainder of a complex request, such as that the implied length is incorrect. It specifically does NOT mean that a data item submitted for storage in a register has a value outside the expectation of the application program, since the Modbus protocol is unaware of the significance of any particular value of any particular register.
4	Slave device failure	An unrecoverable error occurred while the server (or slave) was attempting to perform the requested action.

Table 3.20 Modbus Exception Codes

## 3.9 How to Access Parameters

### 3.9.1 Parameter Handling

The PNU (Parameter Number) is translated from the register address contained in the Modbus read or write message. The parameter number is translated to Modbus as (10 x parameter number) DECIMAL.

### 3.9.2 Storage of Data

The Coil 65 decimal determines whether data written to the frequency converter are stored in EEPROM and RAM (coil 65=1) or only in RAM (coil 65= 0).

### 3.9.3 IND

The array index is set in Holding Register 9 and used when accessing array parameters.

### 3.9.4 Text Blocks

Parameters stored as text strings are accessed in the same way as the other parameters. The maximum text block size is 20 characters. If a read request for a parameter is for more characters than the parameter stores, the response is truncated. If the read request for a parameter is for fewer characters than the parameter stores, the response is space filled.

### 3.9.5 Conversion Factor

The different attributes for each parameter can be seen in the section on factory settings. Since a parameter value can only be transferred as a whole number, a conversion factor must be used to transfer decimals.

### 3.9.6 Parameter Values

#### Standard data types

Standard data types are int16, int32, uint8, uint16 and uint32. They are stored as 4x registers (40001–4FFFF). The parameters are read using function 03HEX "Read Holding Registers." Parameters are written using the function 6HEX "Preset Single Register" for 1 register (16 bits), and the function 10HEX "Preset Multiple Registers" for 2 registers (32 bits). Readable sizes range from 1 register (16 bits) up to 10 registers (20 characters).

#### Non standard data types

Non standard data types are text strings and are stored as 4x registers (40001–4FFFF). The parameters are read using function 03HEX "Read Holding Registers" and written using function 10HEX "Preset Multiple Registers." Readable sizes range from 1 register (2 characters) up to 10 registers (20 characters).

### 3.10 Examples

The following examples illustrate various Modbus RTU commands.

### 3.10.1 Read Coil Status (01 HEX)

#### Description

This function reads the ON/OFF status of discrete outputs (coils) in the frequency converter. Broadcast is never supported for reads.

#### Query

The query message specifies the starting coil and quantity of coils to be read. Coil addresses start at zero, that is, coil 33 is addressed as 32.

Example of a request to read coils 33-48 (Status Word) from slave device 01.

Field Name	Example (HEX)
Slave Address	01 (frequency converter address)
Function	01 (read coils)
Starting Address HI	00
Starting Address LO	20 (32 decimals) Coil 33
No. of Points HI	00
No. of Points LO	10 (16 decimals)
Error Check (CRC)	-

Table 3.21 Query

#### Response

The coil status in the response message is packed as one coil per bit of the data field. Status is indicated as: 1=ON; 0=OFF. The LSB of the first data byte contains the coil addressed in the query. The other coils follow toward the high order end of this byte, and from 'low order to high order' in subsequent bytes.

If the returned coil quantity is not a multiple of eight, the remaining bits in the final data byte is padded with zeros (toward the high order end of the byte). The Byte Count field specifies the number of complete bytes of data.

Field Name	Example (HEX)
Slave Address	01 (frequency converter address)
Function	01 (read coils)
Byte Count	02 (2 bytes of data)
Data (Coils 40-33)	07
Data (Coils 48-41)	06 (STW=0607hex)
Error Check (CRC)	-

Table 3.22 Response

## NOTE

Coils and registers are addressed explicit with an off-set of -1 in Modbus.

I.e. Coil 33 is addressed as Coil 32.

### 3.10.2 Force/Write Single Coil (05 HEX)

#### Description

This function forces the coil to either ON or OFF. When broadcast the function forces the same coil references in all attached slaves.

#### Query

The query message specifies the coil 65 (parameter write control) to be forced. Coil addresses start at zero, that is, coil 65 is addressed as 64. Force Data=00 00HEX (OFF) or FF 00HEX (ON).

Field Name	Example (HEX)
Slave Address	01 (Frequency converter address)
Function	05 (write single coil)
Coil Address HI	00
Coil Address LO	40 (64 decimal) Coil 65
Force Data HI	FF
Force Data LO	00 (FF 00=ON)
Error Check (CRC)	-

Table 3.23 Query

#### Response

The normal response is an echo of the query, returned after the coil state has been forced.

Field Name	Example (HEX)
Slave Address	01
Function	05
Force Data HI	FF
Force Data LO	00
Quantity of Coils HI	00
Quantity of Coils LO	01
Error Check (CRC)	-

Table 3.24 Response

### 3.10.3 Force/Write Multiple Coils (0F HEX)

This function forces each coil in a sequence of coils to either ON or OFF. When broadcast the function forces the same coil references in all attached slaves.

The query message specifies the coils 17 to 32 (speed set-point) to be forced.

Field Name	Example (HEX)
Slave Address	01 (frequency converter address)
Function	0F (write multiple coils)
Coil Address HI	00
Coil Address LO	10 (coil address 17)
Quantity of Coils HI	00
Quantity of Coils LO	10 (16 coils)
Byte Count	02
Force Data HI (Coils 8-1)	20
Force Data LO (Coils 16-9)	00 (ref.=2000 hex)
Error Check (CRC)	-

**Table 3.25 Query**
**Response**

The normal response returns the slave address, function code, starting address, and quantity of coils forced.

Field Name	Example (HEX)
Slave Address	01 (frequency converter address)
Function	0F (write multiple coils)
Coil Address HI	00
Coil Address LO	10 (coil address 17)
Quantity of Coils HI	00
Quantity of Coils LO	10 (16 coils)
Error Check (CRC)	-

**Table 3.26 Response**

### 3.10.4 Read Holding Registers (03 HEX)

**Description**

This function reads the contents of holding registers in the slave.

**Query**

The query message specifies the starting register and quantity of registers to be read. Register addresses start at zero, that is, registers 1-4 are addressed as 0-3.

Example: Read 3-03 *Maximum Reference*, register 03030.

Field Name	Example (HEX)
Slave Address	01
Function	03 (read holding registers)
Starting Address HI	0B (Register address 3029)
Starting Address LO	05 (Register address 3029)
No. of Points HI	00
No. of Points LO	02 - (3-03 <i>Maximum Reference</i> is 32 bits long, i.e. 2 registers)
Error Check (CRC)	-

**Table 3.27 Query**
**Response**

The register data in the response message are packed as two bytes per register, with the binary contents right justified within each byte. For each register, the first byte contains the high-order bits and the second contains the low-order bits.

Example: Hex 000088B8=35.000=15 Hz.

Field Name	Example (HEX)
Slave Address	01
Function	03
Byte Count	04
Data HI (Register 3030)	00
Data LO (Register 3030)	16
Data HI (Register 3031)	E3
Data LO (Register 3031)	60
Error Check (CRC)	-

**Table 3.28 Response**

### 3.10.5 Preset Single Register (06 HEX)

**Description**

This function presets a value into a single holding register.

**Query**

The query message specifies the register reference to be preset. Register addresses start at zero, that is, register 1 is addressed as 0.

Example: Write to 1-00 *Configuration Mode*, register 1000.

Field Name	Example (HEX)
Slave Address	01
Function	06
Register Address HI	03 (Register address 999)
Register Address LO	E7 (Register address 999)
Preset Data HI	00
Preset Data LO	01
Error Check (CRC)	-

**Table 3.29 Query**
**Response**

The normal response is an echo of the query, returned after the register contents have been passed.

Field Name	Example (HEX)
Slave Address	01
Function	06
Register Address HI	03
Register Address LO	E7
Preset Data HI	00
Preset Data LO	01
Error Check (CRC)	-

Table 3.30 Response

### 3.10.6 Preset Multiple Registers (10 HEX)

#### Description

This function presets values into a sequence of holding registers.

#### Query

The query message specifies the register references to be preset. Register addresses start at zero, that is, register 1 is addressed as 0. Example of a request to preset two registers (set 1-24 Motor Current to 738 (7.38 A)):

Field Name	Example (HEX)
Slave Address	01
Function	10
Starting Address HI	04
Starting Address LO	19
No. of Registers HI	00
No. of registers LO	02
Byte Count	04
Write Data HI (Register 4: 1049)	00
Write Data LO (Register 4: 1049)	00
Write Data HI (Register 4: 1050)	02
Write Data LO (Register 4: 1050)	E2
Error Check (CRC)	-

Table 3.31 Query

#### Response

The normal response returns the slave address, function code, starting address, and quantity of registers preset.

Field Name	Example (HEX)
Slave Address	01
Function	10
Starting Address HI	04
Starting Address LO	19
No. of Registers HI	00
No. of registers LO	02
Error Check (CRC)	-

Table 3.32 Response

## 3.11 Danfoss FC Control Profile

### 3.11.1 Control Word According to FC Profile (8-10 Protocol = FC profile)

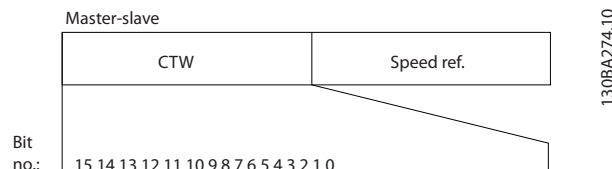

Illustration 3.12 Control Word According to FC Profile

Bit	Bit value=0	Bit value=1
00	Reference value	external selection lsb
01	Reference value	external selection msb
02	DC brake	Ramp
03	Coasting	No coasting
04	Quick stop	Ramp
05	Hold output frequency	use ramp
06	Ramp stop	Start
07	No function	Reset
08	No function	Jog
09	Ramp 1	Ramp 2
10	Data invalid	Data valid
11	Relay 01 open	Relay 01 active
12	Relay 02 open	Relay 02 active
13	Parameter set-up	selection lsb
15	No function	Reverse

Table 3.33 Control Word According to FC Profile

#### Explanation of the control bits

##### Bits 00/01

Bits 00 and 01 are used to choose between the four reference values, which are pre-programmed in 3-10 Preset Reference according to the Table 3.35.

Programmed ref. value	Parameter	Bit 01	Bit 00
1	3-10 Preset Reference [0]	0	0
2	3-10 Preset Reference [1]	0	1
3	3-10 Preset Reference [2]	1	0
4	3-10 Preset Reference [3]	1	1

Table 3.34 Control Bits

## NOTE

Make a selection in *8-56 Preset Reference Select* to define how Bit 00/01 gates with the corresponding function on the digital inputs.

### Bit 02, DC brake

Bit 02='0': leads to DC braking and stop. Set braking current and duration in *2-01 DC Brake Current* and *2-02 DC Braking Time*.

Bit 02='1' leads to ramping.

### Bit 03, Coasting

Bit 03='0': The frequency converter immediately "lets go" of the motor, (the output transistors are "shut off") and it coasts to a standstill.

Bit 03='1': The frequency converter starts the motor if the other starting conditions are met.

Make a selection in *8-50 Coasting Select* to define how Bit 03 gates with the corresponding function on a digital input.

### Bit 04, Quick stop

Bit 04='0': Makes the motor speed ramp down to stop (set in *3-81 Quick Stop Ramp Time*).

### Bit 05, Hold output frequency

Bit 05='0': The present output frequency (in Hz) freezes. Change the frozen output frequency only with the digital inputs (*5-10 Terminal 18 Digital Input* to *5-13 Terminal 29 Digital Input*) programmed to *Speed up=21* and *Slow down=22*.

## NOTE

If Freeze output is active, the frequency converter can only be stopped by the following:

- Bit 03 Coasting stop
- Bit 02 DC braking
- Digital input (*5-10 Terminal 18 Digital Input* to *5-13 Terminal 29 Digital Input*) programmed to *DC braking=5*, *Coasting stop=2*, or *Reset and coasting stop=3*.

### Bit 06, Ramp stop/start

Bit 06='0': Causes a stop and makes the motor speed ramp down to stop via the selected ramp down parameter. Bit 06='1': Permits the Frequency converter to start the motor, if the other starting conditions are met.

Make a selection in *8-53 Start Select* to define how Bit 06 Ramp stop/start gates with the corresponding function on a digital input.

### Bit 07, Reset

Bit 07='0': No reset.

Bit 07='1': Resets a trip. Reset is activated on the signal's leading edge, that is, when changing from logic '0' to logic '1'.

### Bit 08, Jog

Bit 08='1': The output frequency is determined by *3-11 Jog Speed [Hz]*.

### Bit 09, Selection of ramp 1/2

Bit 09="0": Ramp 1 is active (*3-41 Ramp 1 Ramp Up Time* to *3-42 Ramp 1 Ramp Down Time*).

Bit 09="1": Ramp 2 (*3-51 Ramp 2 Ramp Up Time* to *3-52 Ramp 2 Ramp Down Time*) is active.

### Bit 10, Data not valid/Data valid

Tell the frequency converter whether to use or ignore the control word.

Bit 10='0': The control word is ignored.

Bit 10='1': The control word is used. This function is relevant because the telegram always contains the control word, regardless of the telegram type. Turn off the control word if not wanting to use it when updating or reading parameters.

### Bit 11, Relay 01

Bit 11="0": Relay not activated.

Bit 11="1": Relay 01 activated provided that *Control word bit 11=36* is chosen in *5-40 Function Relay*.

### Bit 12, Relay 02

Bit 12="0": Relay 02 is not activated.

Bit 12="1": Relay 02 is activated provided that *Control word bit 12=37* is chosen in *5-40 Function Relay*.

### Bit 13, Selection of set-up

Use bit 13 to choose from the 2 menu set-ups according to the table.

Set-up	Bit 13
1	0
2	1

The function is only possible when *Multi Set-Ups=9* is selected in *0-10 Active Set-up*.

Make a selection in *8-55 Set-up Select* to define how Bit 13 gates with the corresponding function on the digital inputs.

Bit 15 Reverse

Bit 15='0': No reversing.

Bit 15='1': Reversing. In the default setting, reversing is set to digital in 8-54 *Reversing Select*. Bit 15 causes reversing only when Serial communication, Logic or Logic and is selected.

3.11.2 Status Word According to FC Profile (STW) (8-30 Protocol = FC profile)

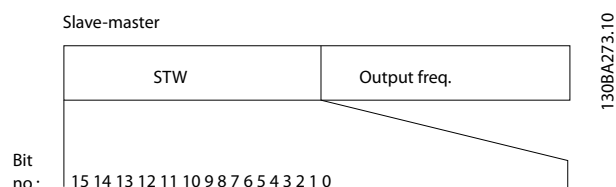

Illustration 3.13 Status Word

Bit	Bit=0	Bit=1
00	Control not ready	Control ready
01	Drive not ready	Drive ready
02	Coasting	Enable
03	No error	Trip
04	No error	Error (no trip)
05	Reserved	-
06	No error	Triplock
07	No warning	Warning
08	Speed ≠ reference	Speed=reference
09	Local operation	Bus control
10	Out of frequency limit	Frequency limit OK
11	No operation	In operation
12	Drive OK	Stopped, auto start
13	Voltage OK	Voltage exceeded
14	Torque OK	Torque exceeded
15	Timer OK	Timer exceeded

Table 3.35 Status Word According to FC Profile

**Explanation of the status bits**

Bit 00, Control not ready/ready

Bit 00='0': The frequency converter trips.

Bit 00='1': The frequency converter controls are ready but the power component does not necessarily receive any power supply (in case of external 24 V supply to controls).

Bit 01, Drive ready

Bit 01='1': The frequency converter is ready for operation but the coasting command is active via the digital inputs or via serial communication.

Bit 02, Coasting stop

Bit 02='0': The frequency converter releases the motor.

Bit 02='1': The frequency converter starts the motor with a start command.

Bit 03, No error/trip

Bit 03='0' : The frequency converter is not in fault mode.

Bit 03='1': The frequency converter trips. To re-establish operation, press [Reset].

Bit 04, No error/error (no trip)

Bit 04='0': The frequency converter is not in fault mode. Bit

04="1": The frequency converter shows an error but does not trip.

Bit 05, Not used

Bit 05 is not used in the status word.

Bit 06, No error / triplock

Bit 06='0': The frequency converter is not in fault mode. Bit

06="1": The frequency converter is tripped and locked.

Bit 07, No warning/warning

Bit 07='0': There are no warnings.

Bit 07='1': A warning has occurred.

Bit 08, Speed≠ reference/speed=reference

Bit 08='0': The motor is running but the present speed is different from the preset speed reference. It might for example, be the case when the speed ramps up/down during start/stop.

Bit 08='1': The motor speed matches the preset speed reference.

Bit 09, Local operation/bus control

Bit 09='0': [Off/Reset] is activate on the control unit or *Local control* in 3-13 *Reference Site* is selected. It is not possible to control the frequency converter via serial communication.

Bit 09='1' It is possible to control the frequency converter via the fieldbus/serial communication.

Bit 10, Out of frequency limit

Bit 10='0': The output frequency has reached the value in 4-12 *Motor Speed Low Limit [Hz]* or 4-14 *Motor Speed High Limit [Hz]*.

Bit 10="1": The output frequency is within the defined limits.

Bit 11, No operation/in operation

Bit 11='0': The motor is not running.

Bit 11='1': The coasting has a start signal or the output frequency is greater than 0 Hz.



Bit 12, Drive OK/stopped, autostart:

Bit 12='0': There is no temporary over temperature on the inverter.  
 Bit 12='1': The inverter stops because of over temperature but the unit does not trip and resumes operation once the over temperature stops.

Bit 13, Voltage OK/limit exceeded

Bit 13='0': There are no voltage warnings.  
 Bit 13='1': The DC voltage in the frequency converter's intermediate circuit is too low or too high.

Bit 14, Torque OK/limit exceeded

Bit 14='0': The motor current is lower than the torque limit selected in *4-18 Current Limit*.  
 Bit 14='1': The torque limit in *4-18 Current Limit* is exceeded.

Bit 15, Timer OK/limit exceeded

Bit 15='0': The timers for motor thermal protection and thermal protection are not exceeded 100%.  
 Bit 15='1': One of the timers exceeds 100%.

### 3.11.3 Bus Speed Reference Value

Speed reference value is transmitted to the frequency converter in a relative value in %. The value is transmitted in the form of a 16-bit word; in integers (0-32767) the value 16384 (4000 Hex) corresponds to 100%. Negative figures are formatted by means of 2's complement. The Actual Output frequency (MAV) is scaled in the same way as the bus reference.

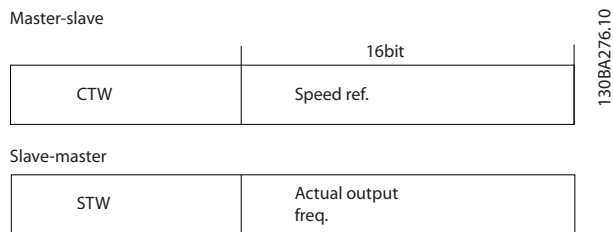

**Illustration 3.14 Actual Output Frequency (MAV)**

The reference and MAV are scaled as follows:

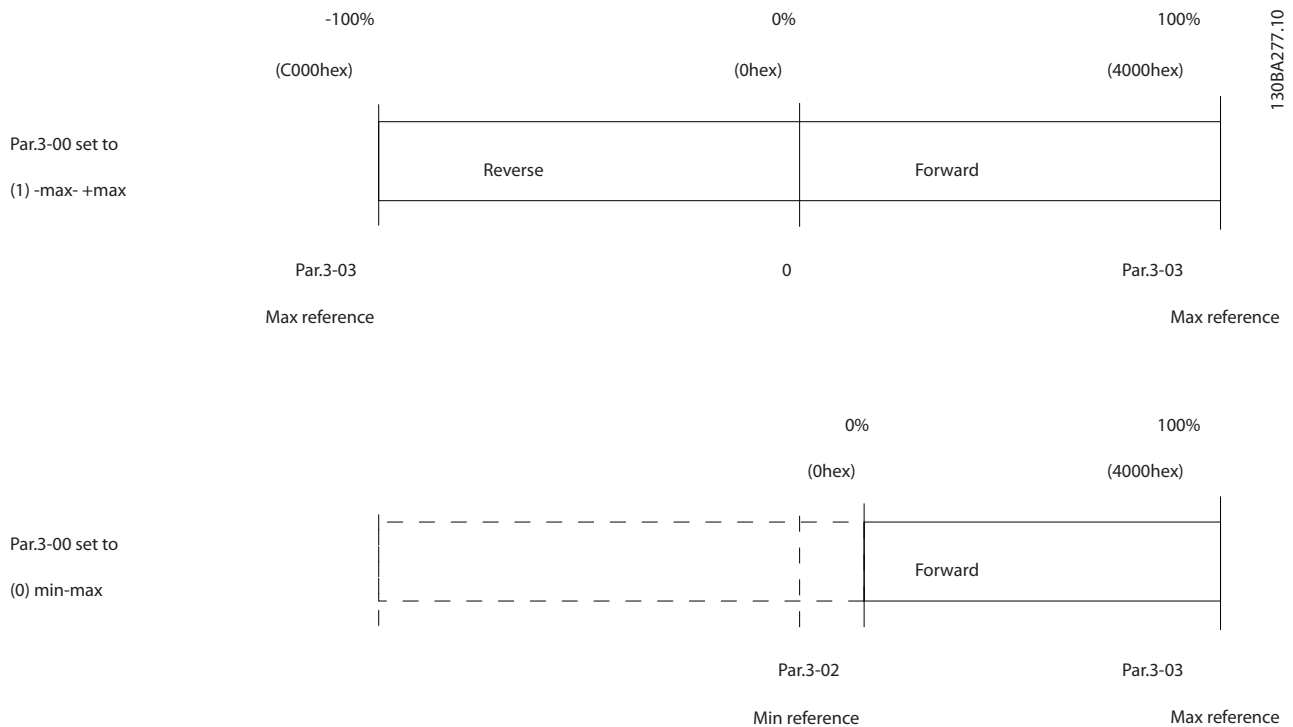

**Illustration 3.15 Reference and MAV**

## 4 Application Examples

The examples in this section are intended as a quick reference for common functionalities.

4

		Parameters	
		Function	Setting
		1-29 Automatic Motor Adaptation (AMA)	[1] Enable complete AMA
		5-12 Terminal 27 Digital Input	[2]* Coast inverse
		* = Default Value	
		<b>Notes/comments:</b> Parameter group 1-2* must be set according to motor	
		<b>NOTE</b> If terminal 12 and 27 are not connected, set 5-12 to [0]	

Table 4.1 AMA with T27 Connected

		Parameters	
		Function	Setting
		6-10 Terminal 53 Low Voltage	0.07 V*
		6-11 Terminal 53 High Voltage	10 V*
		6-14 Terminal 53 Low Ref./Feedb. Value	0RPM
		6-15 Terminal 53 High Ref./Feedb. Value	1500 RPM
		6-19 Terminal 53 Mode	[1] Voltage
		* = Default Value	
		<b>Notes/comments:</b>	

Table 4.2 Analog Speed Reference (Voltage)

		Parameters	
		Function	Setting
		6-12 Terminal 53 Low Current	4 mA*
		6-13 Terminal 53 High Current	20 mA*
		6-14 Terminal 53 Low Ref./Feedb. Value	0 RPM
		6-15 Terminal 53 High Ref./Feedb. Value	1500 RPM
		6-19 Terminal 53 Mode	[0] current
		* = Default Value	
		<b>Notes/comments:</b>	

Table 4.3 Analog Speed Reference (Current)

		Parameters	
		Function	Setting
		5-10 Terminal 18 Digital Input	[8] Start
		5-11 Terminal 19 Digital Input	[10] Reversing*
		5-12 Terminal 27 Digital Input	[0] No operation
		5-14 Terminal 32 Digital Input	[16] Preset ref bit 0
		5-15 Terminal 33 Digital Input	[17] Preset ref bit 1
		3-10 Preset Reference	
		Preset ref. 0	25%
		Preset ref. 1	50%
		Preset ref. 2	75%
		Preset ref. 3	100%
		* = Default Value	
		<b>Notes/comments:</b>	

Table 4.4 Start/Stop with Reversing and 4 Preset Speeds

		Parameters	
		Function	Setting
		5-11 Terminal 19 Digital Input	[1] Reset
		* = Default Value	
		<b>Notes/comments:</b>	

Table 4.5 External Alarm Reset

		Parameters	
		Function	Setting
		6-10 Terminal 53 Low Voltage	0.07 V*
		6-11 Terminal 53 High Voltage	10 V*
		6-14 Terminal 53 Low Ref./Feedb. Value	0 RPM
		6-15 Terminal 53 High Ref./Feedb. Value	1500 RPM
		6-19 Terminal 53 Mode	[1] voltage
		* = Default Value	
		<b>Notes/comments:</b>	

Table 4.6 Speed Reference (using a manual potentiometer)

		Parameters	
		Function	Setting
		4-30 Motor Feedback Loss Function	[1] Warning
		4-31 Motor Feedback Speed Error	100 RPM
		4-32 Motor Feedback Loss Timeout	5 s
		7-00 Speed PID Feedback Source	[2] MCB 102
		17-11 Resolution (PPR)	1024*
		13-00 SL Controller Mode	[1] On
		13-01 Start Event	[19] Warning
		13-02 Stop Event	[44] Reset key
		13-10 Comparato r Operand	[21] Warning no.
		13-11 Comparato r Operator	[1] ≈*
		13-12 Comparato r Value	90
		13-51 SL Controller Event	[22] Comparator 0
		13-52 SL Controller Action	[32] Set digital out A low
		5-40 Function Relay	[80] SL digital output A
		* = Default Value	
		<b>Notes/comments:</b>	
		If the limit in the feedback monitor is exceeded, Warning 90 will be issued. The SLC monitors Warning 90 and in the case that Warning 90 becomes TRUE then Relay 1 is triggered.	
		External equipment may then indicate that service may be required. If the feedback error goes below the limit again within 5 sec. then the drive continues and the warning disappears. But Relay 1 will still be triggered until [Reset] on the LCP.	

Table 4.7 Using SLC to Set a Relay

		Parameters																															
		Function	Setting																														
<table border="1"> <tr><td colspan="2">FC</td></tr> <tr><td>+24 V</td><td>12</td></tr> <tr><td>D IN</td><td>18</td></tr> <tr><td>D IN</td><td>19</td></tr> <tr><td>COM</td><td>20</td></tr> <tr><td>D IN</td><td>27</td></tr> <tr><td>D IN</td><td>29</td></tr> <tr><td>D IN</td><td>32</td></tr> <tr><td>D IN</td><td>33</td></tr> <tr><td>D IN</td><td>31</td></tr> <tr><td colspan="2">+10 V</td></tr> <tr><td>A IN</td><td>53</td></tr> <tr><td>A IN</td><td>54</td></tr> <tr><td>COM</td><td>55</td></tr> <tr><td>A OUT</td><td>42</td></tr> </table>	FC		+24 V	12	D IN	18	D IN	19	COM	20	D IN	27	D IN	29	D IN	32	D IN	33	D IN	31	+10 V		A IN	53	A IN	54	COM	55	A OUT	42		5-10 Terminal 18	[8] Start*
	FC																																
	+24 V	12																															
	D IN	18																															
	D IN	19																															
COM	20																																
D IN	27																																
D IN	29																																
D IN	32																																
D IN	33																																
D IN	31																																
+10 V																																	
A IN	53																																
A IN	54																																
COM	55																																
A OUT	42																																
		Digital Input																															
		5-12 Terminal 27	[19] Freeze Reference																														
		Digital Input																															
		5-13 Terminal 29	[21] Speed Up																														
		Digital Input																															
		5-14 Terminal 32	[22] Speed Down																														
		Digital Input																															
		* = Default Value																															
		<b>Notes/comments:</b>																															

Table 4.8 Speed Up/Down

		Parameters																															
		Function	Setting																														
<table border="1"> <tr><td colspan="2">FC</td></tr> <tr><td>+24 V</td><td>12</td></tr> <tr><td>D IN</td><td>18</td></tr> <tr><td>D IN</td><td>19</td></tr> <tr><td>COM</td><td>20</td></tr> <tr><td>D IN</td><td>27</td></tr> <tr><td>D IN</td><td>29</td></tr> <tr><td>D IN</td><td>32</td></tr> <tr><td>D IN</td><td>33</td></tr> <tr><td>D IN</td><td>31</td></tr> <tr><td colspan="2">+10 V</td></tr> <tr><td>A IN</td><td>53</td></tr> <tr><td>A IN</td><td>54</td></tr> <tr><td>COM</td><td>55</td></tr> <tr><td>A OUT</td><td>42</td></tr> </table>	FC		+24 V	12	D IN	18	D IN	19	COM	20	D IN	27	D IN	29	D IN	32	D IN	33	D IN	31	+10 V		A IN	53	A IN	54	COM	55	A OUT	42		1-90 Motor Thermal Protection	[2] Thermistor trip
	FC																																
	+24 V	12																															
	D IN	18																															
	D IN	19																															
COM	20																																
D IN	27																																
D IN	29																																
D IN	32																																
D IN	33																																
D IN	31																																
+10 V																																	
A IN	53																																
A IN	54																																
COM	55																																
A OUT	42																																
		1-93 Thermistor Source	[1] Analog input 53																														
		6-19 Terminal 53 Mode	[1] Voltage																														
		* = Default Value																															
		<b>Notes/comments:</b>																															
		If only a warning is desired, 1-90 Motor Thermal Protection should be set to [1] Thermistor warning.																															

Table 4.9 Motor Thermistor

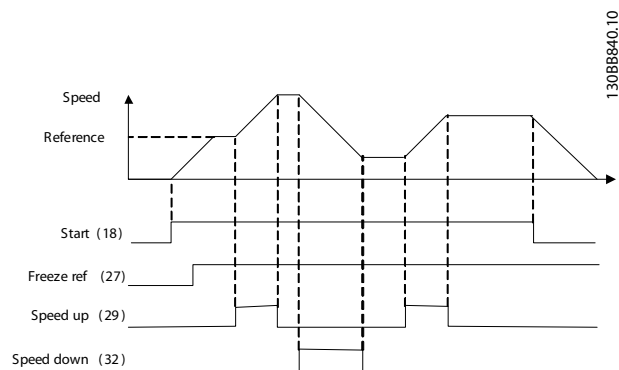

Illustration 4.1

## CAUTION

Thermistors must use reinforced or double insulation to meet PELV insulation requirements.

### 4.1.1 Encoder Connection

The purpose of this guideline is to ease the set-up of encoder connection to the frequency converter. Before setting up the encoder the basic settings for a closed loop speed control system will be shown.

#### Encoder Connection to the frequency converter

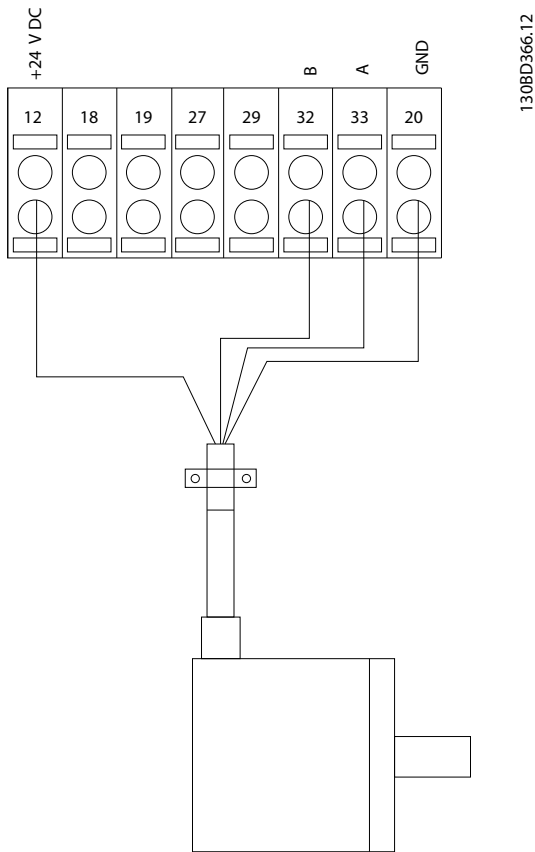

Illustration 4.2 24 V or 10-30 V Encoder

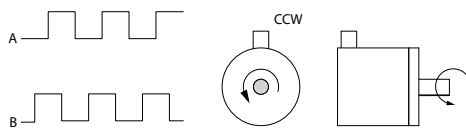
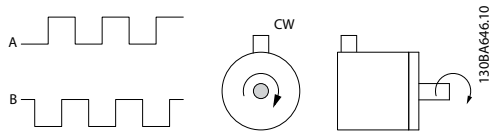

Illustration 4.3 24 V Incremental Encoder. Max. Cable Length 5 m.

### 4.1.2 Encoder Direction

The direction of encoder is determined by which order the pulses are entering the drive.

Clockwise direction means channel A is 90 electrical degrees before channel B.

Counter Clockwise direction means channel B is 90 electrical degrees before A.

The direction determined by looking into the shaft end.

### 4.1.3 Closed Loop Drive System

A drive system consist usually of more elements such as:

- Motor
- Add (Gearbox) (Mechanical Brake)
- Frequency converter
- Encoder as feed-back system
- Brake resistor for dynamic braking
- Transmission
- Load

Applications demanding mechanical brake control will usually need a brake resistor.

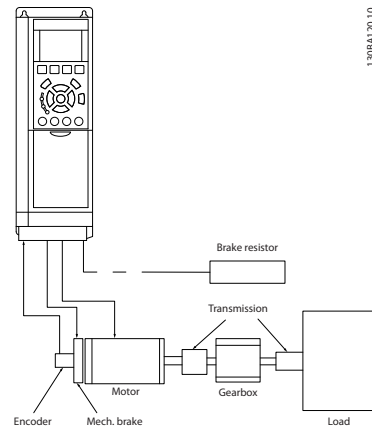
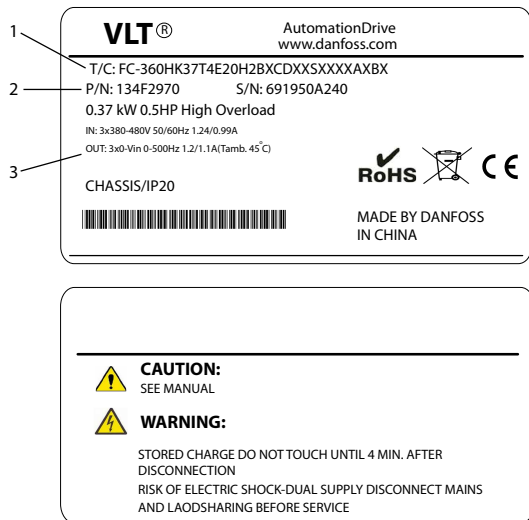

Illustration 4.4 Basic Set-up for Closed Loop Speed Control

# 5 Type Code and Selection

Confirm that the equipment matches the requirements and ordering information by checking power size, voltage and overload data on the name plate of the frequency converter.

5



130BC435.11

Illustration 5.1 Name Plate 1 and 2

- 1) Typecode
- 2) Ordering Number

### 3) Specifications

1-6: Product Name	
7: Overload	H: Heavy Duty Q: Normal Duty <sup>1)</sup>
8-10: Power Size	0.37-75 kW e.g. K37: 0.37 kW 1K1: 1.1 kW 11K: 11 kW etc.
11-12: Voltage Class	4: 380-480 V
13-15: IP Class	E20: IP20
16-17: RFI	H2: C3 Class
18: Braking Chopper	X: No B: Built-in <sup>3)</sup>
19: LCP	X: No
20: PCB Coating	3: 3C3
21: Mains Terminals	D: Load Sharing
29-30: Embedded Fieldbus	AX: No A0: Profibus <sup>2)</sup> AL: Profinet <sup>2)</sup>

Table 5.1 Type Code: Selection of Different Features and Options

See for options and accessories.

- 1) Only 11-75 kW for Normal Duty variants. Fieldbus unavailable for Normal Duty.
- 2) Not available yet.
- 3) 0.37-22 kW with built-in braking chopper. 30-75 kW external braking chopper only.

1	2	3	4	5	6	7	8	9	10	11	12	13	14	15	16	17	18	19	20	21	22	23	24	25	26	27	28	29	30	31	32
F	C	-	3	6	0	H				T	4	E	2	0	H	2	X	X	C	D	X	X	S	X	X	X	X	A	X	B	X
						Q											B											A	0		
																												A	L		

130BC437.10

Illustration 5.2 Typecode String

### 5.1.1 Drive Configurator

It is possible to design a frequency converter according to the application requirements by using the ordering number system.

The Series offers standard frequency converters and frequency converters with integral options by sending a type code string describing the product to the local Danfoss sales office, i.e.:

FC-360HK37T4E20H2BXCXXSXXXXXAXBX

The meaning of the characters in the string can be located in the pages containing the ordering numbers in this chapter.

Use the Internet based Drive Configurator for configuring the right frequency converter for the right application and generate the type code string. The Drive Configurator automatically generates an eight-digit sales number to be delivered to a local sales office.

Furthermore, it is possible to establish a project list with several products and send it to a Danfoss sales representative.

The Drive Configurator can be found on the global Internet site: [www.danfoss.com/drives](http://www.danfoss.com/drives).

Description	Pos	Possible choice
Product group	1-3	FC
Drive series	4-6	FC 360
Power rating	8-10	0.37-75 kW
Phases	11	Three phases (T)
Mains voltage	11-12	T 4: 380-480V AC
Enclosure	13-15	E20: IP20
RFI filter	16-17	H2: Class A2
Brake	18	B: Brake chopper included X: No brake chopper included
Display	19	X: No Local Control Panel
Coating PCB	20	C: Coated PCB
Mains option	21	D: Load sharing
Adaptation	22	X: Standard cable entries
Adaptation	23	X: No adaptation
Software release	24-27	SXXX: Latest release - standard software

Description	Pos	Possible choice
Software language	28	X: Not used

Table 5.2 Ordering Type Code

Description	Pos	Possible choice
Control cassette	29-30	AX: Standard A0: with embedded Profibus AL: with embedded ProfiNet
B options	31-32	BX: No option BR: MCB 102 Encoder option BU: MCB 103 Resolver option

Table 5.3 Overview of Type Code Options

## 5.2 Options and Accessories

Danfoss offers a wide range of options and accessories for VLT® AutomationDrive.

Description	Ordering numbers
Numeric LCP	132B0254 <sup>1</sup>
Numeric LCP IP55 panel mounting	132B0261 <sup>2</sup>
Blind Cover	132B0262 <sup>1</sup>
Standard Control Cassette	132B0255
Decoupling for frame size J1	132B0258
Decoupling for frame size J2 and J3	132B0259

Table 5.4 Options and Accessories

<sup>1</sup> Two kinds of packages, 6 pcs or 72 pcs

<sup>2</sup> 2 pcs in one package

## 5.3 Brake Resistors

In applications where the motor is used as a brake, energy is generated in the motor and send back into the frequency converter. If the energy can not be transported back to the motor it will increase the voltage in the converter DC-line. In applications with frequent braking and/or high inertia loads this increase may lead to an over voltage trip in the converter and finally a shut down. Brake resistors are used to dissipate the excess energy resulting from the regenerative braking. The resistor is selected in respect to its ohmic value, its power dissipation rate and its physical size. Danfoss offers a wide variety of different resistors that are specially designed to our frequency converters. See the section *Control with brake function* for the dimensioning of brake resistors. Code numbers can be found in *5.3.1 Ordering Numbers: Brake Resistors 10%*.

## 5.3.1 Ordering Numbers: Brake Resistors 10%

FC 360	P <sub>m</sub> (H0)	R <sub>min</sub>	R <sub>br. nom</sub>	R <sub>rec</sub>	P <sub>br avg</sub>		Period	Cable cross section <sup>2*</sup>	Therm. relay	Max. brake torque with R <sub>rec</sub> *
T4	[kW]	[Ω]	[Ω]	[Ω]	[kW]	175Uxxxx	[s]	[mm <sup>2</sup> ]	[A]	[%]
HK37	0,37	890	1041,98	989	0,030	3000				139
HK55	0,55	593	693,79	659	0,045	3001				131
HK75	0,75	434	508,78	483	0,061	3002				129
H1K1	1,1	288	338,05	321	0,092	3004				132
H1K5	1,5	208	244,41	232	0,128	3007				145
H2K2	2,2	139	163,95	155	0,190	3008				131
H3K0	3	100	118,86	112	0,262	3300				131
H4K0	4	74	87,93	83	0,354	3335				128
H5K5	5,5	54	63,33	60	0,492	3336				127
H7K5	7,5	38	46,05	43	0,677	3337				132
H11K	11	27	32,99	31	0,945	3338				130
H15K	15	19	24,02	22	1,297	3339				129
H18K	18,5	16	19,36	18	1,610	3340				132
H22K	22	16	18,00	17	1,923	3357				128
H30K	30	11	14,58	13	2,576	3341				150
H37K	37	9	11,71	11	3,206	3359				146
H45K	45	8	9,58	9	3,921	3065				150
H55K	55	6	7,80	7	4,816	3070				150
H75K	75	4	5,68	5	6,612	3231				150

Table 5.5 FC 360 - Mains: 380-480 V (T4), 10% Duty Cycle



### 5.3.2 Ordering Numbers: Brake Resistors 40%

FC 360	P <sub>m</sub> (H0)	R <sub>min</sub>	R <sub>br. nom</sub>	R <sub>rec</sub>	P <sub>br avg</sub>		Period	Cable cross section <sup>2*</sup>	Therm. relay	Max. brake torque with R <sub>rec</sub> *
T4	[kW]	[Ω]	[Ω]	[Ω]	[kW]	175Uxxxx	[s]	[mm <sup>2</sup> ]	[A]	[%]
HK37	0,37	890	1041,98	989	0,030	3101				139
HK55	0,55	593	693,79	659	0,045	3308				131
HK75	0,75	434	508,78	483	0,061	3309				129
H1K1	1,1	288	338,05	321	0,092	3310				132
H1K5	1,5	208	244,41	232	0,128	3311				145
H2K2	2,2	139	163,95	155	0,190	3312				131
H3K0	3	100	118,86	112	0,262	3313				131
H4K0	4	74	87,93	83	0,354	3314				128
H5K5	5,5	54	63,33	60	0,492	3315				127
H7K5	7,5	38	46,05	43	0,677	3316				132
H11K	11	27	32,99	31	0,945	3236				130
H15K	15	19	24,02	22	1,297	3237				129
H18K	18,5	16	19,36	18	1,610	3238				132
H22K	22	16	18,00	17	1,923	3203				128
H30K	30	11	14,58	13	2,576	3206				150
H37K	37	9	11,71	11	3,206	3210				146
H45K	45	8	9,58	9	3,921	3213				150
H55K	55	6	7,80	7	4,816	3216				150
H75K	75	4	5,68	5	6,612	3216				150

Table 5.6 FC 360 - Mains: 380-480 V (T4), 40% Duty Cycle

## 5.4 Sine-wave Filters

When a motor is controlled by a frequency converter, resonance noise will be heard from the motor. This noise, which is the result of the design of the motor, arises every time an inverter switch in the frequency converter is activated. The frequency of the resonance noise thus corresponds to the switching frequency of the frequency converter.

For the FC 360, Danfoss can supply a Sine-wave filter to dampen the acoustic motor noise.

The filter reduces the ramp-up time of the voltage, the peak load voltage  $U_{PEAK}$  and the ripple current  $\Delta I$  to the motor, which means that current and voltage become almost sinusoidal. Consequently, the acoustic motor noise is reduced to a minimum.

The ripple current in the Sine-wave Filter coils, will also cause some noise. Solve the problem by integrating the filter in a cabinet or similar.

## 6 Specifications

### 6.1 Power-dependent Specifications

#### 6.1.1 Mains Supply 3 x 380-480 V AC

Frequency converter	HK 37	HK 55	HK75	H1K1	H1K5	H2K2	H3K0	H4K0	H5K5	H7K5
Typical Shaft Output [kW]	0.37	0.55	0.75	1.1	1.5	2.2	3	4	5.5	7.5
Enclosure IP20	J1	J1	J1	J1	J1	J1	J2	J2	J2	J3
<b>Output current</b>										
Shaft output [kW]	0.37	0.55	0.75	1.1	1.5	2.2	3	4	5.5	7.5
Continuous (3 x 380-439 V) [A]	1.2	1.7	2.2	3	3.7	5.3	7.2	9	12	15.5
Continuous (3 x 440-480 V) [A]	1.1	1.6	2.1	3	3.4	4.8	6.3	8.2	11	14
Intermittent (60 s overload) [A]	1.9	2.7	3.5	4.8	5.9	8.5	11.5	14.4	19.2	24.8
Continuous kVA (400 V AC) [kVA]	0.84	1.18	1.53	2.08	2.57	3.68	4.99	6.24	8.32	10.74
Continuous kVA (460 V AC) [kVA]	0.91	1.34	1.75	2.5	2.8	4.01	5.24	6.82	9.15	11.64
<b>Max. input current</b>										
Continuous (3 x 380-439 V) [A]	1.2	1.6	2.1	2.6	3.5	4.7	6.3	8.3	11.2	15.1
Continuous (3 x 440-480 V) [A]	1.0	1.2	1.8	2.0	2.9	3.9	4.3	6.8	9.4	12.6
Intermittent (60 s overload) [A]	1.9	2.6	3.4	4.2	5.6	7.5	10.1	13.3	17.9	24.2
<b>Additional specifications</b>										
Max. cable cross section (mains, motor, brake and load sharing) [mm <sup>2</sup> (AWG)] <sup>2)</sup>	4 mm <sup>2</sup>									
Estimated power loss at rated max. load [W] <sup>3)</sup>						52.36			113.85	150.75
Weight, enclosure IP20	2.3	2.3	2.3	2.3	2.3	2.5	3.6	3.6	3.6	4.1
Efficiency <sup>4)</sup>						97.62%			98%	98%

Table 6.1 Mains Supply 3 x 380-480 V AC - Heavy Duty <sup>1)</sup>

Frequency converter	H11K	H15K	H18K	H22K	H30K	H37K	H45K	H55K	H75K
<b>Typical Shaft Output [kW]</b>	<b>11</b>	<b>15</b>	<b>18.5</b>	<b>22</b>	<b>30</b>	<b>37</b>	<b>45</b>	<b>55</b>	<b>75</b>
IP20	J4	J4	J5	J5	J6	J6	J6	J7	J7
<b>Output current</b>									
Continuous (3 x 380-439 V) [A]	23	31	37	42.5					
Continuous (3 x 440-480 V) [A]	21	27	34	40					
Intermittent (60 s overload) [A]	34.5	46.5	55.5	63.8					
Continuous kVA (400 V AC) [kVA]	15.94	21.48	25.64	29.45					
Continuous kVA 460 V AC) [kVA]	17.46	22.45	28.27	33.26					
<b>Max. input current</b>									
Continuous (3 x 380-439 V) [A]	22.1	29.9	35.2	41.5					
Continuous (3 x 440-480 V) [A]	18.4	24.7	29.3	34.6					
Intermittent (60 s overload) [A]	33.2	44.9	52.8	62.3					
<b>Additional specifications</b>									
Max. cable size (mains, motor, brake) [mm <sup>2</sup> / AWG] <sup>2)</sup>	16 mm <sup>2</sup>	16 mm <sup>2</sup>	16 mm <sup>2</sup>	16 mm <sup>2</sup>	50 mm <sup>2</sup>	50 mm <sup>2</sup>	50 mm <sup>2</sup>	50 mm <sup>2</sup>	85 mm <sup>2</sup>
Estimated power loss at rated max. load [W] <sup>3)</sup>									
Weight enclosure IP20 [kg]	9.4	9.5	12.3	12.5					
Efficiency <sup>4)</sup>									

**Table 6.2 Mains Supply 3x380-480 V AC - Heavy Duty<sup>1)</sup>**

Frequency converter	Q11K	Q15K	Q18K	Q22K	Q30K	Q37K	Q45K	Q55K	Q75K
<b>Typical Shaft Output [kW]</b>	<b>11</b>	<b>15</b>	<b>18.5</b>	<b>22</b>	<b>30</b>	<b>37</b>	<b>45</b>	<b>55</b>	<b>75</b>
IP20	J4	J4	J5	J5	J6	J6	J6	J7	J7
<b>Output current</b>									
Continuous (3x380-439 V) [A]	23	31	37	42.5					
Continuous (3x440-480 V) [A]	21	27	34	40					
Intermittent (60 s overload) [A]	25.3	34.1	40.7	46.8					
Continuous kVA (400 V AC) [kVA]									
Continuous kVA 460 V AC) [kVA]									
<b>Max. input current</b>									
Continuous (3x380-439 V) [A]	22.1	29.9	35.2	41.5					
Continuous (3x440-480 V) [A]	18.4	24.7	29.3	34.6					
Intermittent (60 s overload) [A]	24.3	32.9	38.7	45.7					
<b>Additional specifications</b>									
Max. cable size (mains, motor, brake) [mm <sup>2</sup> / AWG] <sup>2)</sup>	16 mm <sup>2</sup>			50 mm <sup>2</sup>				85 mm <sup>2</sup>	
Estimated power loss at rated max. load [W] <sup>3)</sup>									
Weight enclosure IP20 [kg]	9.4	9.5	12.3	12.5					
Efficiency <sup>4)</sup>									

**Table 6.3 Mains Supply 3x380-480 V AC - Normal Duty<sup>1)</sup>**

1) Heavy duty = 160% current during 60 s, Normal duty = 110% current during 60 s.

2) American Wire Gauge.

3) The typical power loss is at nominal load conditions and expected to be within  $\pm 15\%$  (tolerance relates to variety in voltage and cable conditions).

Values are based on a typical motor efficiency (eff2/eff3 border line). Motors with lower efficiency will also add to the power loss in the frequency converter and opposite.

If the switching frequency is increased compared to the default setting, the power losses may rise significantly.

LCP and typical control card power consumptions are included. Further options and customer load may add up to 30 W to the losses. (Though typical only 4 W extra for a fully loaded control card, or fieldbus, or options for slot B).

Although measurements are made with state of the art equipment, some measurement inaccuracy must be allowed for ( $\pm 5\%$ ).

4) Measured using 5 m screened motor cables at rated load and rated frequency.

## 6.2 General Specifications

### Mains Supply (L1, L2, L3)

Supply Terminals	L1, L2, L3
Supply voltage	380-480 V:-15 (-25) <sup>1)</sup> to +10%

*1) The frequency converter can run at -25% input voltage with reduced performance. The maximum output power of the frequency converter is 75% in case of -25% input voltage and 85% in case of -15% input voltage.*

#### Mains voltage low/mains drop-out:

*During low mains voltage or a mains drop-out, the frequency converter continues until the intermediate circuit voltage drops below the minimum stop level, which corresponds typically to 15% below the frequency converter's lowest rated supply voltage. Power-up and full torque cannot be expected at mains voltage lower than 10% below the frequency converter's lowest rated supply voltage.*

Supply frequency	50/60 Hz ±5%
Max. imbalance temporary between mains phases	3.0 % of rated supply voltage
True Power Factor (λ)	≥ 0.9 nominal at rated load
Displacement Power Factor (cos φ)	near unity (> 0.98)
Switching on input supply L1, L2, L3 (power-ups) ≤ 7.5 kW	maximum 2 times/min.
Switching on input supply L1, L2, L3 (power-ups) 11-75 kW	maximum 1 time/min.

*The unit is suitable for use on a circuit capable of delivering not more than 100,000 RMS symmetrical Amperes, 480 V maximum.*

### Motor Output (U, V, W)

Output voltage	0-100% of supply voltage
Output frequency (0.37-75 kW)	0-500 Hz
Output frequency in VVC <sup>plus</sup> Mode	0-200 Hz
Switching on output	Unlimited
Ramp times	0.01-3600 s

*<sup>1)</sup> Voltage and power dependent*

### Torque Characteristics

Starting torque (constant torque)	maximum 160% for 60 s <sup>1)</sup>
Overload torque (constant torque)	maximum 160% for 60 s <sup>1)</sup>
Starting torque (variable torque)	maximum 110% for 60 s <sup>1)</sup>
Overload torque (variable torque)	maximum 110% for 60 s
Starting current	maximum 200% for 1 s
Torque rise time in VVC <sup>plus</sup> (independent of fsw)	10 ms

*<sup>1)</sup> Percentage relates to the nominal torque.*

*<sup>2)</sup> The torque response time depends on application and load but as a general rule, the torque step from 0 to reference is 4-5 x torque rise time.*

### Control Cable Lengths and Cross Sections<sup>1)</sup>

Max. motor cable length, screened	50 m
Max. motor cable length, unscreened	100 m
Maximum cross section to control terminals, flexible/ rigid wire	2.5 mm <sup>2</sup> /14 AWG
Minimum cross section to control terminals	0.55 mm <sup>2</sup> / 30AWG

*<sup>1)</sup>For power cables, see electrical data tables.*

### Digital Inputs

Programmable digital inputs	7
Terminal number	18, 19, 27 <sup>1)</sup> , 29 <sup>1)</sup> , 32, 33, 31
Logic	PNP or NPN
Voltage level	0-24 V DC
Voltage level, logic '0' PNP	< 5 V DC
Voltage level, logic '1' PNP	> 10 V DC
Voltage level, logic '0' NPN <sup>2)</sup>	> 19 V DC
Voltage level, logic '1' NPN <sup>2)</sup>	< 14 V DC
Maximum voltage on input	28 V DC

Pulse frequency range	4-32 kHz
(Duty cycle) Min. pulse width	4.5 ms
Input resistance, $R_i$	approx. 4 k $\Omega$
<b>Analog Inputs</b>	
Number of analog inputs	2
Terminal number	53, 54
Modes	Voltage or current
Mode select	software
Voltage mode	
Voltage level	0-10 V
Input resistance, $R_i$	approx. 10 k $\Omega$
Max. voltage	-15 to +20 V
Current mode	
Current level	0/4 to 20 mA (scaleable)
Input resistance, $R_i$	approx. 200 $\Omega$
Max. current	30 mA
Resolution for analog inputs	11 bit (+ sign)
Accuracy of analog inputs	Max. error 0.5% of full scale
Bandwidth	100 Hz

The analog inputs are galvanically isolated from the supply voltage (PELV) and other high-voltage terminals.

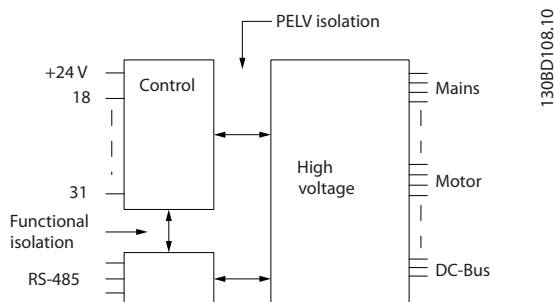

**Illustration 6.1 Analog Inputs**

<b>Pulse Inputs</b>	
Programmable pulse inputs	2
Terminal number pulse	32, 33
Max. frequency at terminal, 29, 33	32 kHz (Push-pull driven)
Max. frequency at terminal, 29, 33	5 kHz (open collector)
Min. frequency at terminal 29, 33	4 Hz
Voltage level	see section on Digital input
Maximum voltage on input	28 V DC
Input resistance, $R_i$	approx. 4 k $\Omega$
Pulse input accuracy (0.1-1 kHz)	Max. error: 0.1% of full scale
<b>Analog Outputs</b>	
Number of programmable analog outputs	2
Terminal number	45, 42
Current range at analog output	0/4-20 mA
Max. resistor load to common at analog output	500 $\Omega$
Accuracy on analog output	Max. error: 0.8 % of full scale
Resolution on analog output	10 bit

The analog output is galvanically isolated from the supply voltage (PELV) and other high-voltage terminals.

**Control Card, RS-485 Serial Communication**

Terminal number	68 (P,TX+, RX+), 69 (N,TX-, RX-)
Terminal number 61	Common for terminals 68 and 69

The RS-485 serial communication circuit is functionally seated from other central circuits and galvanically isolated from the supply voltage (PELV).

**Digital Outputs**

Programmable digital/pulse outputs	2
Terminal number	27, 29 <sup>1)</sup>
Voltage level at digital/frequency output	0-24 V
Max. output current (sink or source)	40 mA
Max. load at frequency output	1 kΩ
Max. capacitive load at frequency output	10 nF
Minimum output frequency at frequency output	0 Hz
Maximum output frequency at frequency output	32 kHz
Accuracy of frequency output	Max. error: 0.1 % of full scale
Resolution of frequency outputs	10 bit

1) Terminal 27 and 29 can also be programmed as input.

The digital output is galvanically isolated from the supply voltage (PELV) and other high-voltage terminals.

**Control Card, 24 V DC Output**

Terminal number	12
Max. load	100 mA

The 24 V DC supply is galvanically isolated from the supply voltage (PELV), but has the same potential as the analog and digital inputs and outputs.

**Relay Outputs**

Programmable relay outputs	2
Relay 01 and 02	01-03 (NC), 01-02 (NO), 04-06 (NC), 04-05 (NO)
Max. terminal load (AC-1) <sup>1)</sup> on 01-02/04-05 (NO) (Resistive load)	250 V AC, 3 A
Max. terminal load (AC-15) <sup>1)</sup> on 01-02/04-05 (NO) (Inductive load @ cosφ 0.4)	250 V AC, 0.2 A
Max. terminal load (DC-1) <sup>1)</sup> on 01-02/04-05 (NO) (Resistive load)	30 V DC, 2 A
Max. terminal load (DC-13) <sup>1)</sup> on 01-02/04-05 (NO) (Inductive load)	24 V DC, 0.1 A
Max. terminal load (AC-1) <sup>1)</sup> on 01-03/04-06 (NC) (Resistive load)	250 V AC, 3 A
Max. terminal load (AC-15) <sup>1)</sup> on 01-03/04-06 (NC) (Inductive load @ cosφ 0.4)	250 V AC, 0.2 A
Max. terminal load (DC-1) <sup>1)</sup> on 01-03/04-06 (NC) (Resistive load)	30 V DC, 2 A
Min. terminal load on 01-03 (NC), 01-02 (NO)	24 V DC 10 mA, 24 V AC 20 mA

1) IEC 60947 t 4 and 5

The relay contacts are galvanically isolated from the rest of the circuit by reinforced isolation (PELV).

**Control Card, +10 V DC Output**

Terminal number	50
Output voltage	10.5 V ±0.5 V
Max. load	15 mA

The 10 V DC supply is galvanically isolated from the supply voltage (PELV) and other high-voltage terminals.

**Control Characteristics**

Resolution of output frequency at 0-500 Hz	± 0.003 Hz
System response time (terminals 18, 19, 27, 29, 32, 33)	≤ 2 ms
Speed control range (open loop)	1:100 of synchronous speed
Speed accuracy (open loop)	30-4000 RPM: Maximum error of ±8 RPM

All control characteristics are based on a 4-pole asynchronous motor

**Surroundings**

Enclosure type J1-J7	IP20, IP21/Type 1
Vibration test all enclosure types	1.0 g
Relative humidity	5-95% (IEC 721-3-3; Class 3K3 (non-condensing) during operation
Aggressive environment (IEC 60068-2-43) H <sub>2</sub> S test	class Kd
Test method according to IEC 60068-2-43 H <sub>2</sub> S (10 days)	
Ambient temperature (at 60 AVM switching mode)	
- with derating	max. 55 °C <sup>1)</sup>
- with full output power of typical EFF2 motors (up to 90% output current)	max. 50 °C <sup>1)</sup>
- at full continuous FC output current	max. 45 °C <sup>1)</sup>
Minimum ambient temperature during full-scale operation	0 °C
Minimum ambient temperature at reduced performance	- 10 °C
Temperature during storage/transport	-25 to +65/70 °C
Maximum altitude above sea level without derating	1000 m
Maximum altitude above sea level with derating	3000 m
EMC standards, Emission	EN 61800-3, EN 61000-6-3/4, EN 55011, IEC 61800-3 EN 61800-3, EN 61000-6-1/2,
EMC standards, Immunity	EN 61000-4-2, EN 61000-4-3, EN 61000-4-4, EN 61000-4-5, EN 61000-4-6
<b>Control Card Performance</b>	
Scan interval	1 ms

**Protection and Features**

- Electronic thermal motor protection against overload.
- Temperature monitoring of the heatsink ensures that the frequency converter trips if the temperature reaches 95 °C ± 5 °C. An overload temperature cannot be reset until the temperature of the heatsink is below 70 °C ± 5 °C (Guideline - these temperatures may vary for different power sizes, enclosures etc.). The frequency converter has an auto derating function to avoid its heatsink reaching 95 °C.
- The frequency converter is protected against short-circuits on motor terminals U, V, W.
- If a mains phase is missing, the frequency converter trips or issues a warning (depending on the load).
- Monitoring of the intermediate circuit voltage ensures that the frequency converter trips if the intermediate circuit voltage is too low or too high.
- The frequency converter is protected against earth faults on motor terminals U, V, W.



### 6.3 Efficiency

#### Efficiency of the frequency converter ( $\eta_{VLT}$ )

The load on the has little effect on its efficiency. In general, the efficiency is the same at the rated motor frequency  $f_{M,N}$ , even if the motor supplies 100% of the rated shaft torque or only 75%, i.e. in case of part loads.

This also means that the efficiency of the frequency converter does not change even if other U/f characteristics are chosen.

However, the U/f characteristics influence the efficiency of the motor.

The efficiency declines a little when the switching frequency is set to a value of above 5 kHz. The efficiency will also be slightly reduced if the mains voltage is 480 V, or if the motor cable is longer than 30 m.

#### Frequency converter efficiency calculation

Calculate the efficiency of the frequency converter at different loads based on *Illustration 6.2*. The factor in this graph must be multiplied with the specific efficiency factor listed in :

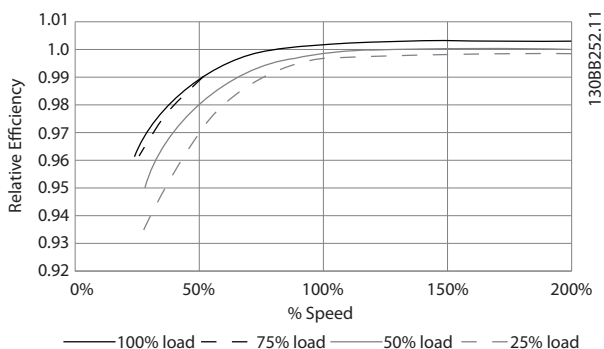

Illustration 6.2 Typical Efficiency Curves

#### Efficiency of the motor ( $\eta_{MOTOR}$ )

The efficiency of a motor connected to the frequency converter depends on magnetizing level. In general, the efficiency is just as good as with mains operation. The efficiency of the motor depends on the type of motor.

In the range of 75-100% of the rated torque, the efficiency of the motor is practically constant, both when it is controlled by the frequency converter and when it runs directly on mains.

In small motors, the influence from the U/f characteristic on efficiency is marginal. However, in motors from 11 kW and up, the advantages are significant.

In general, the switching frequency does not affect the efficiency of small motors. Motors from 11kW and up have

their efficiency improved (1-2%). This is because the sine shape of the motor current is almost perfect at high switching frequency.

#### Efficiency of the system ( $\eta_{SYSTEM}$ )

To calculate the system efficiency, the efficiency of the frequency converter ( $\eta_{VLT}$ ) is multiplied by the efficiency of the motor ( $\eta_{MOTOR}$ ):

$$\eta_{SYSTEM} = \eta_{VLT} \times \eta_{MOTOR}$$

### 6.4 Acoustic Noise

The acoustic noise from the frequency converter comes from three sources:

1. DC intermediate circuit coils.
2. Integral fan.
3. RFI filter choke.

The typical values measured at a distance of 1 m from the unit:

Frame size	At reduced fan speed (50%) [dBA] ***	Full fan speed [dBA]
J1 (0.37-2.2 kW)	46	51
J2 (3.0-5.5 kW)	51	55.5
J3 (7.5 kW)	51	54

Table 6.4 Typical Measured Values

### 6.5 dU/dt Conditions

When a transistor in the inverter bridge switches, the voltage across the motor increases by a dU/dt ratio depending on:

- the motor cable (type, cross-section, length screened or unscreened)
- inductance

The natural induction causes an overshoot  $U_{PEAK}$  in the motor voltage before it stabilises itself at a level depending on the voltage in the intermediate circuit. The rise time and the peak voltage  $U_{PEAK}$  affect the service life of the motor. If the peak voltage is too high, especially motors without phase coil insulation are affected. If the motor cable is short (a few metres), the rise time and peak voltage are lower. If the motor cable is long (100 m), the rise time and peak voltage are higher.

Peak voltage on the motor terminals is caused by the switching of the IGBTs. The FC 360 complies with the demands of IEC 60034-25 regarding motors designed to be controlled by frequency converters. The FC 360 also

complies with IEC 60034-17 regarding Norm motors controlled by frequency converters  
Measured values from lab tests:

Cable length [m]	Mains voltage [V]	Rise time [μsec]	Upeak [kV]	dU/dt [kV/μsec]
5	400	0.164	0.98	5.4
50	400	0.292	1.04	2.81
5	400	0.184	1.2	5.27
50	400	0.352	1.42	3.19
5	480	0.168	1.09	5.27
50	480	0.32	1.23	3.08

Table 6.5 FC 360, H2K2T4

Cable length [m]	Mains voltage [V]	Rise time [μsec]	Upeak [kV]	dU/dt [kV/μsec]
5	400	0.18	0.86	3.84
50	400	0.376	0.96	2.08
5	400	0.232	1.03	3.54
50	400	0.432	1.43	2.64
5	480	0.196	0.97	3.98
50	480	0.38	1.19	2.5

Table 6.6 FC 360, H5K5T4

Cable length [m]	Mains voltage [V]	Rise time [μsec]	Upeak [kV]	dU/dt [kV/μsec]
5	400	0.166	0.992	4.85
50	400	0.372	1.08	2.33
5	400	0.188	1.19	5.24
50	400	0.36	1.46	3.25
5	480	0.168	1.1	5.2
50	480	0.352	1.25	2.85

Table 6.7 FC 360, H7K5T4

Cable length [m]	Mains voltage [V]	Rise time [μsec]	Upeak [kV]	dU/dt [kV/μsec]
5	400	0.224	0.99	3.54
50	400	0.392	1.07	2.19
5	400	0.332	0.855	2.07
50	400	0.456	1.51	2.65
5	480	0.236	1.14	3.87
50	480	0.408	1.33	2.61

Table 6.8 FC 360, H15KT4

## 6.6 Special Conditions

Under some special conditions, where the operation of the frequency converter is challenged, derating must be taken into account. In some conditions, derating must be done manually.

In other conditions, the frequency converter automatically performs a degree of derating when necessary. This is done in order to ensure the performance at critical stages where the alternative could be a trip.

### 6.6.1 Manual Derating

Manual derating must be considered for:

- Air pressure – for installation at altitudes above 1 km
- Motor speed – at continuous operation at low RPM in constant torque applications
- Ambient temperature – above 45 °C (for some types above 50 °C), for details, see *Table 6.9* and *Table 6.10*.

Frame size	Power size [kW]	Max. output current at 45 °C	Max. output current at 50 °C
J1	0.37	1.2	1.2
	0.55	1.7	1.7
	0.75	2.2	2.2
	1.1	3.0	3.0
	1.5	3.7	3.0
J2	2.2	5.3	4.1
	3	7.2	7.2
	4	9.0	9.0
J3	5.5	12.0	10.2
	7.5	15.5	13.1
J4	11	23.0	23.0
	15	31.0	N/A
J5	18.5	37.0	37.0
	22	42.5	40.0

Table 6.9 Derating at 380 V

Frame size	Power size [kW]	Max. output current at 45 °C	Max. output current at 50 °C
J1	0.37	1.1	1.1
	0.55	1.6	1.6
	0.75	2.1	2.1
	1.1	3.0	2.8
	1.5	3.4	2.8
	2.2	4.8	3.8
J2	3	6.3	6.3
	4	8.2	8.2
	5.5	11.0	9.4
J3	7.5	14.0	11.9
J4	11	21.0	21.0
	15	27.0	N/A
J5	18.5	34.0	34.0
	22	40.0	37.7

Table 6.10 Derating at 480 V

### 6.6.2 Automatic Derating

The frequency converter constantly checks for critical levels:

- Critical high temperature on the control card or heatsink
- High motor load
- High DC link voltage
- Low motor speed

As a response to a critical level, the frequency converter adjusts the switching frequency. For critical high internal temperatures and low motor speed, the frequency converter can also force the PWM pattern to SFAVM.

**Index**

**A**  
**Abbreviations**..... 4  
**Acoustic Noise**..... 73  
**Aggressive Environments**..... 10  
**Air Humidity**..... 10  
**AMA With T27 Connected**..... 58  
**Analog**  
    Inputs..... 70  
    Outputs..... 70

**B**  
**Brake**  
    Function..... 38  
    Power..... 6, 38  
    Resistor..... 36  
    Resistors..... 63  
**Break-away Torque**..... 5

**C**  
**Catch Up/slow Down**..... 17  
**CE**  
    Conformity And Labelling..... 9  
    Conformity And Labelling?..... 9  
**Coasting**..... 56, 5, 55  
**Conducted Emission**..... 33  
**Control**  
    Cable Lengths And Cross Sections..... 69  
    Card Performance..... 72  
    Card, 24 V DC Output..... 71  
    Card, RS-485 Serial Communication..... 71  
    Characteristics..... 71  
    Word..... 54

**D**  
**Data Types Supported By The Frequency Converter**..... 45  
**DC Brake**..... 55  
**Dead**  
    Band..... 20  
    Band Around Zero..... 20  
**Definitions**..... 5  
**Derating**..... 72  
**Digital**  
    Inputs..... 69  
    Outputs..... 71  
**Disposal Instruction**..... 8  
**Drive Configurator**..... 63

**E**  
**Earth Leakage Current**..... 35

**Efficiency**..... 73  
**EMC**  
    EMC..... 72  
    Directive (2004/108/EC)..... 9  
    Directive 2004/108/EC..... 10  
    Precautions..... 42  
    Test Results..... 33  
**Extreme Running Conditions**..... 39

**F**  
**FC**  
    Profile..... 54  
    With Modbus RTU..... 42  
**Freeze**  
    Output..... 5  
    Reference..... 17  
**Frequency**  
    Converter Hardware Set-up..... 41  
    Converter Set-up..... 43  
    Converter With Modbus RTU..... 47  
**Function Codes Supported By Modbus RTU**..... 50

**G**  
**General Aspects Of EMC Emissions**..... 32

**H**  
**Hold Output Frequency**..... 55  
**How To Control The Frequency Converter**..... 50

**I**  
**IEC 61800-3**..... 72  
**Immunity Requirements**..... 34  
**Index (IND)**..... 45  
**Intermediate Circuit**..... 39, 73  
**Internal Current Control In VCplus Mode**..... 15

**J**  
**Jog**..... 5, 55

**L**  
**LCP**..... 5, 6, 15  
**Leakage Current**..... 35  
**Local (Hand On) And Remote (Auto On) Control**..... 15  
**Low-voltage Directive (2006/95/EC)**..... 9

**M**  
**Machinery Directive (2006/42/EC)**..... 9

<b>Mains</b>		<b>RS-485</b>	
Drop-out.....	39	RS-485.....	41
Supply.....	7	Installation And Set-up.....	41
Supply (L1, L2, L3).....	69		
Supply 3 X 380-480 V AC.....	66		
<b>Mechanical Holding Brake</b> .....	36	<b>S</b>	
<b>Modbus</b>		<b>Safety Precautions</b> .....	7
Communication.....	41	<b>Scaling</b>	
Exception Codes.....	51	Of Analog And Pulse References And Feedback.....	18
RTU Overview.....	46	Of Preset References And Bus References.....	18
<b>Moment Of Inertia</b> .....	39	<b>Short Circuit (Motor Phase – Phase)</b> .....	39
<b>Motor</b>		<b>Sine-wave</b>	
Output.....	69	Filter.....	65
Phases.....	39	Filters.....	65
Protection.....	72	<b>Special Conditions</b> .....	74
Thermal Protection.....	57, 40	<b>Speed</b>	
Voltage.....	73	PID.....	13, 14
<b>Motor-generated Over-voltage</b> .....	39	PID Control.....	24
		Reference.....	58
		<b>Static Overload In VVCplus Mode</b> .....	40
<b>N</b>		<b>Status Word</b> .....	56
<b>Network</b>		<b>Supply Voltage</b> .....	70
Configuration.....	47	<b>Surroundings</b> .....	72
Connection.....	41	<b>Switching On The Output</b> .....	39
		<b>Symbols</b> .....	4
<b>O</b>		<b>Synchronous Motor Speed</b> .....	5
<b>Open Loop</b> .....	71		
<b>Output Current</b> .....	71	<b>T</b>	
		<b>Telegram Length (LGE)</b> .....	43
<b>P</b>		<b>Thermistor</b> .....	7, 60
<b>Parameter</b>		<b>Torque</b>	
Number (PNU).....	45	Characteristics.....	69
Values.....	51	Control.....	13
<b>PELV</b>		<b>V</b>	
PELV.....	60, 71	<b>Vibration And Shock</b> .....	10
- Protective Extra Low Voltage.....	35	<b>Voltage Level</b> .....	69
<b>Process PID Control</b> .....	27	<b>WVCplus</b> .....	7, 14
<b>Protection</b>			
Protection.....	10, 35	<b>W</b>	
And Features.....	72	<b>What Is Covered</b> .....	9
<b>Protocol Overview</b> .....	42		
<b>Pulse Inputs</b> .....	70		
<b>R</b>			
<b>Radiated Emission</b> .....	33		
<b>Rated Motor Speed</b> .....	5		
<b>RCD</b> .....	6		
<b>Read Holding Registers (03 HEX)</b> .....	53		
<b>Reference Limits</b> .....	17		
<b>Relay Outputs</b> .....	71		
<b>Reset</b> .....	72		
<b>Rise Time</b> .....	73		