

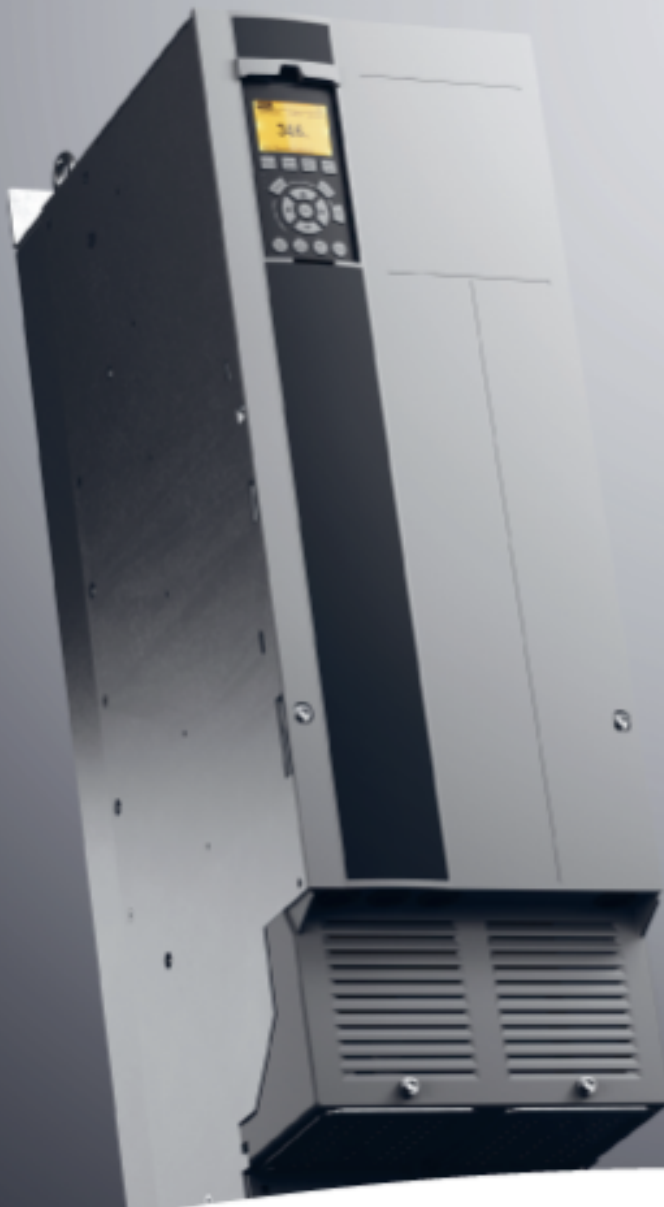

Operating Guide

VLT[®] AutomationDrive FC 361

90–315 kW, Enclosure Sizes J8–J9



Contents

1 Introduction	3
1.1 Purpose of the Manual	3
1.2 Additional Resources	3
1.3 Manual and Software Version	3
1.4 Approvals and Certifications	3
1.5 Disposal	3
2 Safety	4
2.1 Safety Symbols	4
2.2 Qualified Personnel	4
2.3 Safety Precautions	4
3 Product Overview	6
3.1 Intended Use	6
3.2 Power Ratings, Weights, and Dimensions	6
3.3 Interior View of J8 Drive	7
3.4 Interior View of J9 Drive	8
3.5 View of Control Shelf	9
3.6 Local Control Panel (LCP)	10
3.7 LCP Menus	12
4 Mechanical Installation	13
4.1 Items Supplied	13
4.2 Tools Needed	13
4.3 Storage	13
4.4 Operating Environment	14
4.5 Installation and Cooling Requirements	15
4.6 Lifting the Drive	16
4.7 Mounting the Drive	16
5 Electrical Installation	18
5.1 Safety Instructions	18
5.2 EMC-compliant Installation	18
5.3 Wiring Schematic	21
5.4 Connecting to Ground	22
5.5 Connecting the Motor	24
5.6 Connecting the AC Mains	26
5.7 Terminal Dimensions	28
5.8 Control Wiring	32
6 Pre-start Check List	36

7 Commissioning	37
7.1 Applying Power	37
7.2 Programming the Drive	37
7.3 Testing Before System Start-up	39
7.4 System Start-up	39
7.5 Parameter Setting	40
8 Wiring Configuration Examples	41
8.1 Introduction	41
8.2 Wiring for Open-loop Speed Control	41
8.3 Wiring for Start/Stop	42
8.4 Wiring for External Alarm Reset	43
8.5 Wiring for a Motor Thermistor	43
9 Maintenance, Diagnostics, and Troubleshooting	44
9.1 Maintenance and Service	44
9.2 Heat Sink Access Panel	44
9.3 Status Messages	45
9.4 Warning and Alarm Types	47
9.5 List of Warnings and Alarms	48
9.6 Troubleshooting	56
10 Specifications	59
10.1 Electrical Data, 380-480 V	59
10.2 Mains Supply	61
10.3 Motor Output and Motor Data	61
10.4 Ambient Conditions	61
10.5 Cable Specifications	62
10.6 Control Input/Output and Control Data	62
10.7 Fuses and Circuit Breakers	65
10.8 Fastener Tightening Torques	66
10.9 Enclosure Dimensions	67
11 Appendix	73
11.1 Abbreviations and Conventions	73
11.2 Parameter Menu Structure	73
Index	77

1 Introduction

1.1 Purpose of the Manual

This operating guide provides information for safe installation and commissioning of the VLT® drives.

The operating guide is intended for use by qualified personnel. To use the unit safely and professionally, read and follow this operating guide. Pay particular attention to the safety instructions and general warnings. Always keep the operating guide with the drive.

VLT® is a registered trademark.

1.2 Additional Resources

Other resources are available to understand advanced drive functions and programming.

- The *programming guide* provides greater detail on working with parameters and many application examples.
- The *design guide* provides detailed information about capabilities and functionality to design motor control systems.
- Instructions for operation with optional equipment.

Supplementary publications and manuals are available from Danfoss. See www.danfoss.com/en/search/?filter=type%3Adocumentation%2Csegment%3Adds for listings.

1.3 Manual and Software Version

This manual is regularly reviewed and updated. All suggestions for improvement are welcome. *Table 1.1* shows the version of the manual and the corresponding software version.

Manual version	Software version
MG06I2xx	1.0x

Table 1.1 Manual and Software Version

1.4 Approvals and Certifications



1.5 Disposal



Do not dispose of equipment containing electrical components together with domestic waste.
Collect it separately in accordance with local and currently valid legislation.

2

2 Safety

2.1 Safety Symbols

The following symbols are used in this guide:

⚠ WARNING

Indicates a potentially hazardous situation that could result in death or serious injury.

⚠ CAUTION

Indicates a potentially hazardous situation that could result in minor or moderate injury. It can also be used to alert against unsafe practices.

NOTICE

Indicates important information, including situations that can result in damage to equipment or property.

2.2 Qualified Personnel

Correct and reliable transport, storage, installation, operation, and maintenance are required for the trouble-free and safe operation of the drive. Only qualified personnel are allowed to install or operate this equipment. Only authorized personnel are allowed to service and repair this equipment.

Qualified personnel are defined as trained staff, who are authorized to install, commission, and maintain equipment, systems, and circuits in accordance with pertinent laws and regulations. Also, the personnel must be familiar with the instructions and safety measures described in this manual.

Authorized personnel are qualified personnel, trained by Danfoss to service Danfoss products.

2.3 Safety Precautions

⚠ WARNING

HIGH VOLTAGE

Drives contain high voltage when connected to AC mains input, DC supply, load sharing, or permanent motors. Failure to use qualified personnel to install, start up, and maintain the drive can result in death or serious injury.

- Only qualified personnel must install, start up, and maintain the drive.

⚠ WARNING

UNINTENDED START

When the drive is connected to the AC mains, DC supply, or load sharing, the motor can start at any time. Unintended start during programming, service, or repair work can result in death, serious injury, or property damage. The motor can start with an external switch, a fieldbus command, an input reference signal from the LCP or LOP, via remote operation using MCT 10 Set-up Software, or after a cleared fault condition.

To prevent unintended motor start:

- Press [Off/Reset] on the LCP before programming parameters.
- Disconnect the drive from the mains.
- Completely wire and assemble the drive, motor, and any driven equipment before connecting the drive to the AC mains, DC supply, or load sharing.

⚠ WARNING

DISCHARGE TIME

The drive contains DC-link capacitors, which can remain charged even when the drive is not powered. High voltage can be present even when the warning LED indicator lights are off. Failure to wait the specified time after power has been removed before performing service or repair work can result in death or serious injury.

- Stop the motor.
- Disconnect AC mains and remote DC-link power supplies, including battery back-ups, UPS, and DC-link connections to other drives.
- Disconnect or lock PM motor.
- Wait for the capacitors to discharge fully. The minimum waiting time is 20 minutes.
- Before performing any service or repair work, use an appropriate voltage measuring device to make sure that the capacitors are fully discharged.

⚠ WARNING

LEAKAGE CURRENT HAZARD

Leakage currents exceed 3.5 mA. Failure to ground the drive properly can result in death or serious injury.

- Ensure the correct grounding of the equipment by a certified electrical installer.

⚠ WARNING**EQUIPMENT HAZARD**

Contact with rotating shafts and electrical equipment can result in death or serious injury.

- Ensure that only trained and qualified personnel install, start up, and maintain the drive.
- Ensure that electrical work conforms to national and local electrical codes.
- Follow the procedures in this guide.

⚠ WARNING**UNINTENDED MOTOR ROTATION
WINDMILLING**

Unintended rotation of permanent magnet motors creates voltage and can charge the unit, resulting in death, serious injury, or equipment damage.

- Ensure that permanent magnet motors are blocked to prevent unintended rotation.

⚠ WARNING**INTERNAL FAILURE HAZARD**

Under certain circumstances, an internal failure can cause a component to explode. Failure to keep the enclosure closed and properly secured can cause death or serious injury.

- Do not operate the drive with the door open or panels off.
- Ensure that the enclosure is properly closed and secured during operation.

⚠ CAUTION**HOT SURFACES**

The drive contains metal components that are still hot even after the drive has been powered off. Failure to observe the high temperature symbol (yellow triangle) on the drive can result in serious burns.

- Be aware that internal components, such as busbars, can be extremely hot even after the drive has been powered off.
- Exterior areas marked by the high-temperature symbol (yellow triangle) are hot while the drive is in use and immediately after being powered off.

3 Product Overview

3

3.1 Intended Use

The drive is an electronic motor controller that converts AC mains input into a variable AC waveform output. The frequency and voltage of the output are regulated to control the motor speed or torque. The drive is designed to:

- Regulate motor speed in response to system feedback or to remote commands from external controllers.
- Monitor system and motor status.
- Provide motor overload protection.

The drive is designed for industrial and commercial environments in accordance with local laws and standards. Depending on configuration, the drive can be used in standalone applications or form part of a larger system or installation.

NOTICE

In a residential environment, this product can cause radio interference, in which case supplementary mitigation measures can be required.

Foreseeable misuse

Do not use the drive in applications which are non-compliant with specified operating conditions and environments. Ensure compliance with the conditions specified in *chapter 10 Specifications*.

3.2 Power Ratings, Weights, and Dimensions

For enclosure sizes and power ratings of the drives, refer to *Table 3.1*. For more dimensions, see *chapter 10.9 Enclosure Dimensions*.

Enclosure size		J8	J9
IP		20	20
NEMA		Chassis	Chassis
Shipping dimensions [mm (in)]	Height	587 (23)	587 (23)
	Width	997 (39)	1170 (46)
	Depth	460 (18)	535 (21)
Drive dimensions [mm (in)]	Height	909 (36)	1122 (44)
	Width	250 (10)	350 (14)
	Depth	375 (15)	375 (15)
Maximum weight [kg (lb)]		98 (216)	164 (362)

Table 3.1 Power Ratings, Weight, and Dimensions, Enclosure Sizes J8–J9, 380–480 V

3.3 Interior View of J8 Drive

Illustration 3.1 shows the J8 components relevant to installation and commissioning.

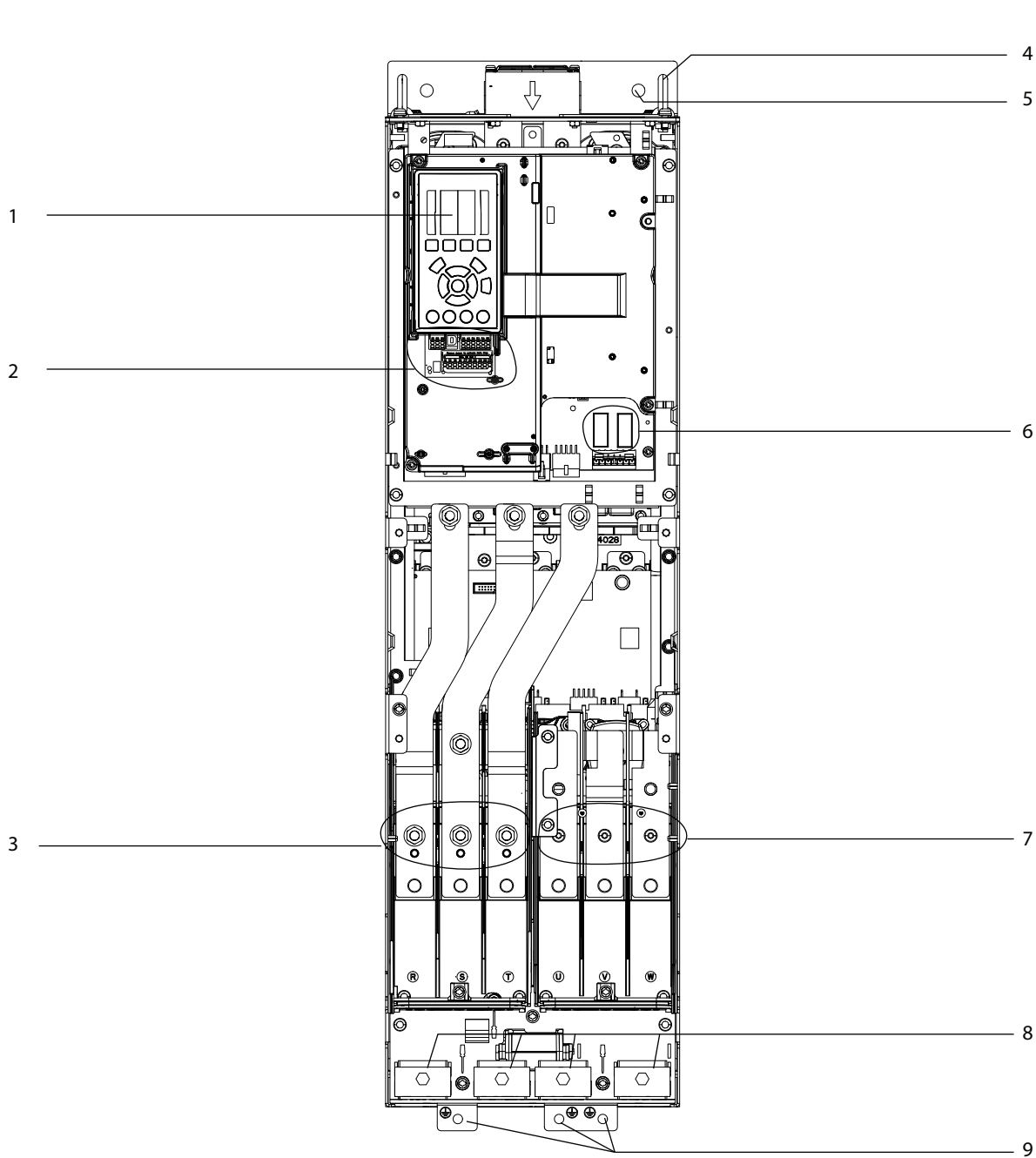

e30bg478.11

1	LCP (local control panel)	6	Relays 1 and 2
2	Control terminals	7	Motor output terminals 96 (U), 97 (V), 98 (W)
3	Mains input terminals 91 (L1), 92 (L2), 93 (L3)	8	Cable clamps
4	Lifting ring	9	Ground terminals
5	Mounting hole	-	-

Illustration 3.1 Interior View of J8 Drive

3.4 Interior View of J9 Drive

Illustration 3.2 shows the J9 components relevant to installation and commissioning.

3

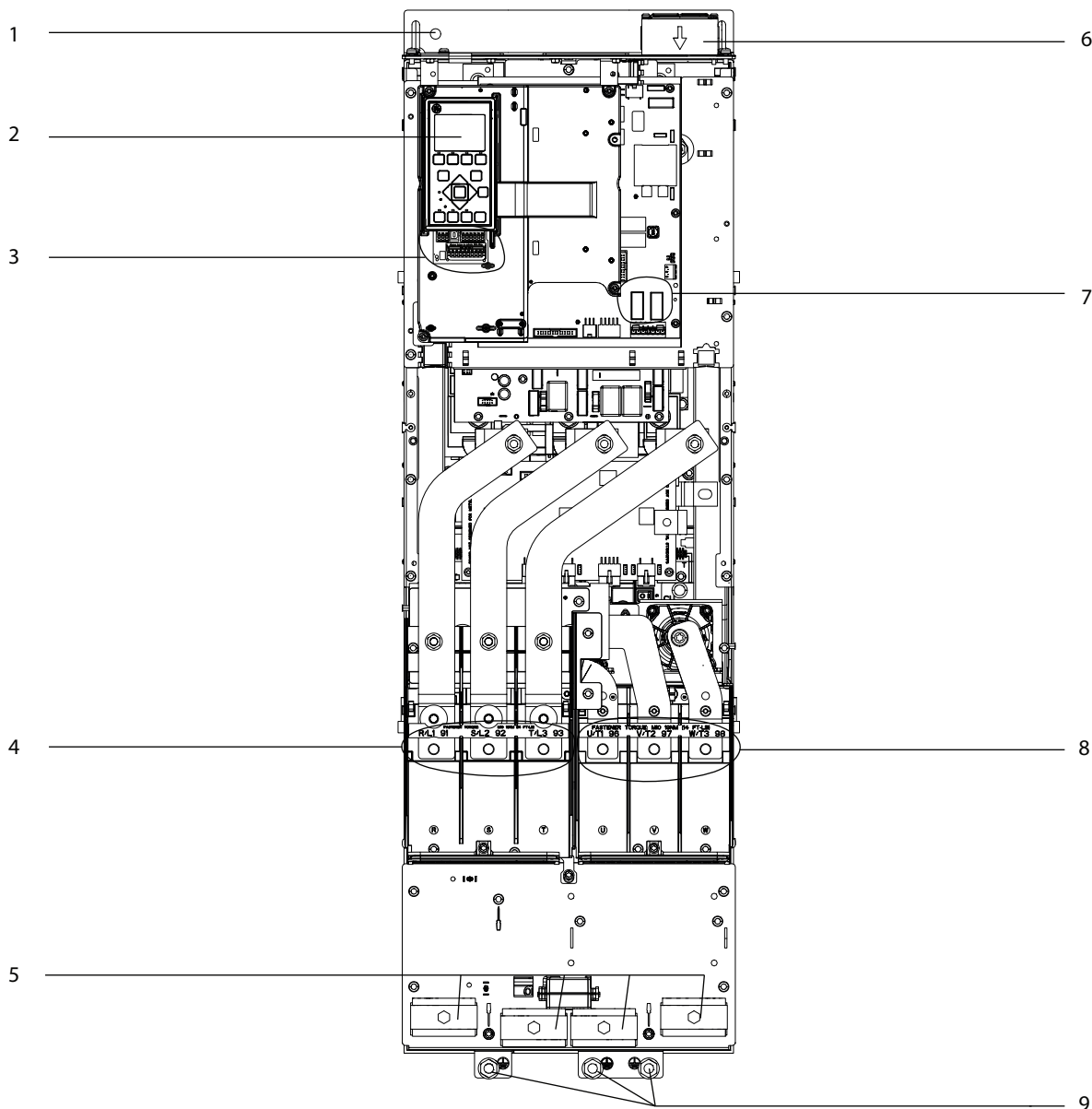

e30bg479.11

1	Mounting hole	6	Top fan
2	LCP (local control panel)	7	Relays 1 and 2
3	Control terminals	8	Motor output terminals 96 (U), 97 (V), 98 (W)
4	Mains input terminals 91 (L1), 92 (L2), 93 (L3)	9	Ground terminals
5	Cable clamps	-	-

Illustration 3.2 Interior View of J9 Drive

3.5 View of Control Shelf

The control shelf holds the keypad, known as the local control panel or LCP. The control shelf also includes the control terminals, relays, and various connectors.

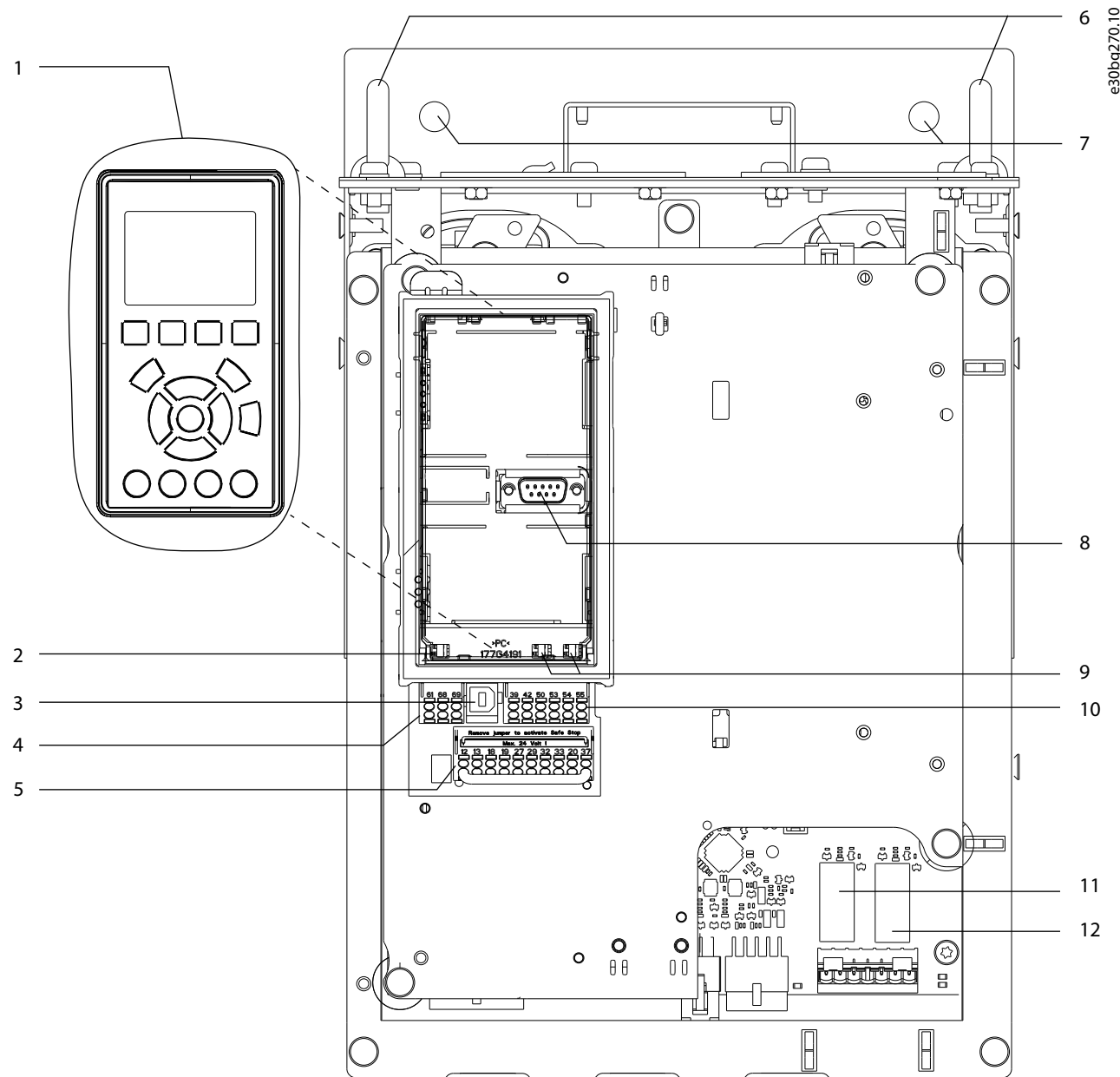

1	Local control panel (LCP)	7	Mounting holes
2	RS485 termination switch	8	LCP connector
3	USB connector	9	Analog switches (A53, A54)
4	RS485 fieldbus connector	10	Analog I/O connector
5	Digital I/O and 24 V supply	11	Relay 1 (01, 02, 03) on power card
6	Lifting rings	12	Relay 2 (04, 05, 06) on power card

Illustration 3.3 View of Control Shelf

3.6 Local Control Panel (LCP)

The local control panel (LCP) is the combined display and keypad on the front of the drive.

The LCP is used to:

- Control the drive and motor.
- Access drive parameters and program the drive.
- Display operational data, drive status, and warnings.

A numeric local control panel (NLCP) is available as an option. The NLCP operates in a manner similar to the LCP, but there are differences. For details on how to use the NLCP, see the product-specific *programming guide*.

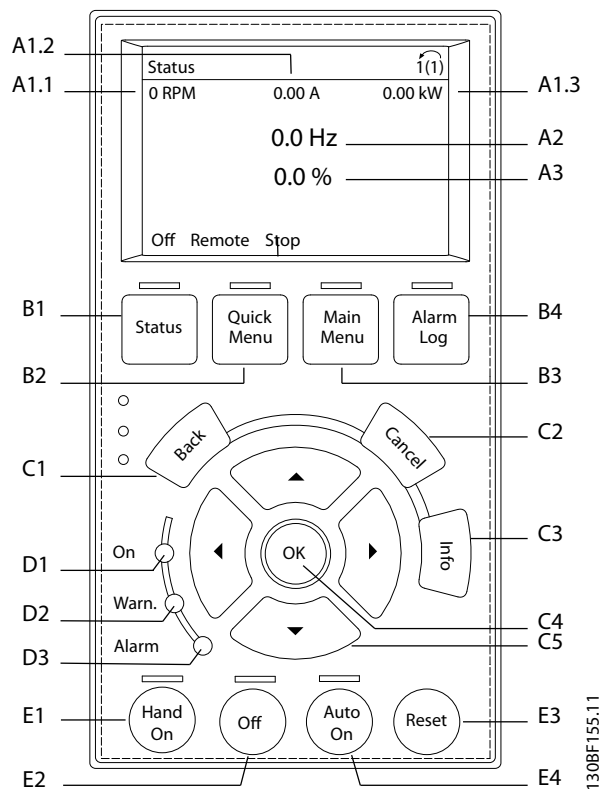

Illustration 3.4 Local Control Panel (LCP)

A. Display area

Each display readout has a parameter associated with it. See *Table 3.2*. The information shown on the LCP can be customized for specific applications. Refer to *chapter 3.7.1.2 Q1 My Personal Menu*.

Callout	Parameter	Default setting
A1.1	Parameter 0-20 Display Line 1.1 Small	Speed [RPM]
A1.2	Parameter 0-21 Display Line 1.2 Small	Motor current [A]
A1.3	Parameter 0-22 Display Line 1.3 Small	Power [kW]
A2	Parameter 0-23 Display Line 2 Large	Frequency [Hz]
A3	Parameter 0-24 Display Line 3 Large	kWh counter

Table 3.2 LCP Display Area

B. Menu keys

Menu keys are used to access the menus for setting up parameters, toggling through status display modes during normal operation, and viewing fault log data.

Callout	Key	Function
B1	Status	Shows operational information.
B2	Quick Menu	Allows access to parameters for initial set-up instructions. Also provides detailed application steps. Refer to <i>chapter 3.7.1.1 Quick Menu Mode</i> .
B3	Main Menu	Allows access to all parameters. Refer to <i>chapter 3.7.1.6 Main Menu Mode</i> .
B4	Alarm Log	Shows a list of current warnings and the last 10 alarms.

Table 3.3 LCP Menu Keys

C. Navigation keys

Navigation keys are used for programming functions and moving the display cursor. The navigation keys also provide speed control in local (hand) operation. To adjust the display brightness, press [Status] and [▲]/[▼] keys.

Callout	Key	Function
C1	Back	Reverts to the previous step or list in the menu structure.
C2	Cancel	Cancels the last change or command as long as the display mode has not changed.
C3	Info	Shows a definition of the selected function.
C4	OK	Accesses parameter groups or enables an option.
C5	▲ ▼ ◀ ▶	Moves between items in the menu.

Table 3.4 LCP Navigation Keys

D. Indicator lights

Indicator lights are used to identify the drive status and to provide a visual notification of warning or fault conditions.

Callout	Indicator	Indicator light	Function
D1	On	Green	Lights when the drive receives power from the mains voltage or a 24 V external supply.
D2	Warn.	Yellow	Lights when warning conditions are active. Text appears in the display area identifying the problem.
D3	Alarm	Red	Lights during a fault condition. Text appears in the display area identifying the problem.

Table 3.5 LCP Indicator Lights

E. Operation keys and reset

The operation keys are found toward the bottom of the local control panel.

Callout	Key	Function
E1	Hand On	Starts the drive in local control. An external stop signal by control input or serial communication overrides the local [Hand On].
E2	Off	Stops the motor but does not remove power to the drive.
E3	Auto On	Puts the system in remote operational mode so it can respond to an external start command by control terminals or serial communication.
E4	Reset	Resets the drive manually after a fault has been cleared.

Table 3.6 LCP Operation Keys and Reset

3.7 LCP Menus

3.7.1.1 Quick Menu Mode

The Quick Menu mode provides a list of menus used to configure and operate the drive. Select the Quick Menu mode by pressing the [Quick Menu] key. The resulting readout appears on the LCP display.

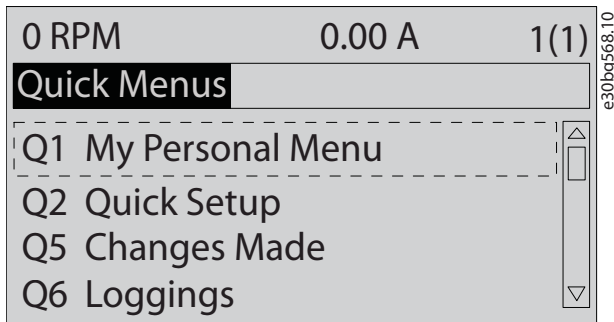

Illustration 3.5 Quick Menu View

3.7.1.2 Q1 My Personal Menu

Use *My Personal Menu* to determine what is shown in the display area. Refer to *chapter 3.6 Local Control Panel (LCP)*. This menu can also show up to 50 pre-programmed parameters. These 50 parameters are manually entered using *parameter 0-25 My Personal Menu*.

3.7.1.3 Q2 Quick Setup

The parameters found in *Q2 Quick Setup* contain basic system and motor data that are always necessary for configuring the drive. See *chapter 7.2.3 Entering System Information* for the set-up procedures.

3.7.1.4 Q5 Changes Made

Select *Q5 Changes Made* for information about:

- The 10 most recent changes.
- Changes made from default setting.

3.7.1.5 Q6 Loggings

Use *Q6 Loggings* for fault finding. To get information about the display line readout, select *Loggings*. The information is shown as graphs. Only parameters selected in *parameter 0-20 Display Line 1.1 Small* through *parameter 0-24 Display Line 3 Large* can be viewed. It is possible to store up to 120 samples in the memory for later reference.

Q6 Loggings	
Parameter 0-20 Display Line 1.1 Small	Speed [RPM]
Parameter 0-21 Display Line 1.2 Small	Motor Current
Parameter 0-22 Display Line 1.3 Small	Power [kW]
Parameter 0-23 Display Line 2 Large	Frequency
Parameter 0-24 Display Line 3 Large	Reference %

Table 3.7 Logging Parameter Examples

3.7.1.6 Main Menu Mode

The *Main Menu* mode lists all the parameter groups available to the drive. Select the *Main Menu* mode by pressing the [Main Menu] key. The resulting readout appears on the LCP display.

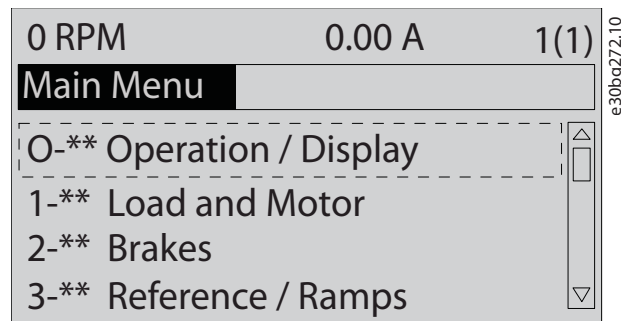

Illustration 3.6 Main Menu View

All parameters can be changed in the main menu. Option cards added to the unit enable extra parameters associated with the option device.

4 Mechanical Installation

4.1 Items Supplied

Items supplied may vary according to product configuration.

- Make sure that the items supplied and the information on the nameplate correspond to the order confirmation.
- Check the packaging and the drive visually for damage caused by inappropriate handling during shipment. File any claim for damage with the carrier. Retain damaged parts for clarification.

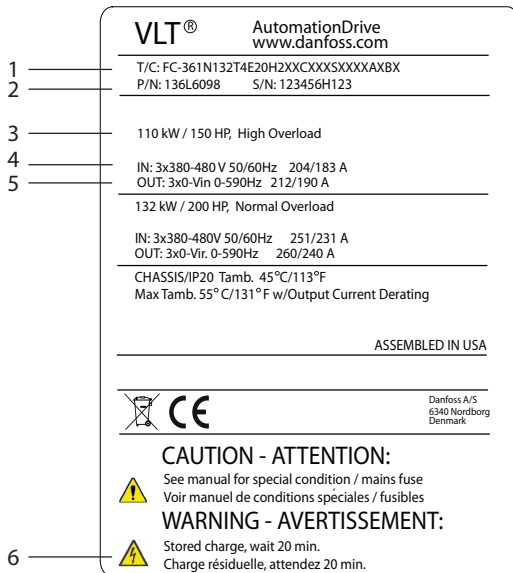

e30bg567.11

1	Type code
2	Part number and serial number
3	Power rating
4	Input voltage, frequency, and current
5	Output voltage, frequency, and current
6	Discharge time

Illustration 4.1 Example Nameplate for Drive Only (J8–J9)

NOTICE

LOSS OF WARRANTY

Do not remove the nameplate from the drive. Removing the nameplate can result in loss of warranty.

4.2 Tools Needed

Receiving/unloading

- I-beam and hooks rated to lift the weight of the drive. Refer to *chapter 3.2 Power Ratings, Weights, and Dimensions*.
- Crane or other lifting aid to place the unit into position.

Installation

- Drill with 10 mm (0.39 in) or 12 mm (0.47 in) drill bits.
- Tape measurer.
- Various sizes of Phillips and flat bladed screwdrivers.
- Wrench with relevant metric sockets (7–17 mm).
- Wrench extensions.
- Torx drives (T25 and T50).
- Sheet metal punch for conduits or cable glands.
- I-beam and hooks to lift the weight of the drive. Refer to *chapter 3.2 Power Ratings, Weights, and Dimensions*.
- Crane or other lifting aid to place the drive onto pedestal and into position.

4.3 Storage

Store the drive in a dry location. Keep the equipment sealed in its packaging until installation. Refer to *chapter 10.4 Ambient Conditions* for recommended ambient temperature.

Periodic forming (capacitor charging) is not necessary during storage unless storage exceeds 12 months.

4.4 Operating Environment

NOTICE

In environments with airborne liquids, particles, or corrosive gases, ensure that the IP/type rating of the equipment matches the installation environment. Failure to meet requirements for ambient conditions can reduce the lifetime of the drive. Ensure that requirements for air humidity, temperature, and altitude are met.

Voltage [V]	Altitude restrictions
380–480	At altitudes above 3000 m (9842 ft), contact Danfoss regarding PELV.

Table 4.1 Installation at High Altitudes

For detailed ambient conditions specifications, refer to *chapter 10.4 Ambient Conditions*.

NOTICE

CONDENSATION

Moisture can condense on the electronic components and cause short circuits. Avoid installation in areas subject to frost. Install an optional space heater when the drive is colder than the ambient air. Operating in standby mode reduces the risk of condensation as long as the power dissipation keeps the circuitry free of moisture.

NOTICE

EXTREME AMBIENT CONDITIONS

Hot or cold temperatures compromise unit performance and longevity.

- Do not operate in environments where the ambient temperature exceeds 55 °C (131 °F).
- The drive can operate at temperatures down to -10 °C (14 °F). However, proper operation at rated load is only guaranteed at 0 °C (32 °F) or higher.
- If temperature exceeds ambient temperature limits, extra air conditioning of the cabinet or installation site is required.

4.4.1 Gases

Aggressive gases, such as hydrogen sulfide, chlorine, or ammonia can damage the electrical and mechanical components. The unit uses conformal-coated circuit boards to reduce the effects of aggressive gases. For conformal-coating class specifications and ratings, see *chapter 10.4 Ambient Conditions*.

4.4.2 Dust

When installing the drive in dusty environments, pay attention to the following:

Periodic maintenance

When dust accumulates on electronic components, it acts as a layer of insulation. This layer reduces the cooling capacity of the components, and the components become warmer. The hotter environment decreases the life of the electronic components.

Keep the heat sink and fans free from dust buildup. For more service and maintenance information, refer to *chapter 9 Maintenance, Diagnostics, and Troubleshooting*.

Cooling fans

Fans provide airflow to cool the drive. When fans are exposed to dusty environments, the dust can damage the fan bearings and cause premature fan failure. Also, dust can accumulate on fan blades causing an imbalance which prevents the fans from properly cooling the unit.

4.4.3 Potentially Explosive Atmospheres

⚠ WARNING

EXPLOSIVE ATMOSPHERE

Do not install the drive in a potentially explosive atmosphere. Install the unit in a cabinet outside of this area. Failure to follow this guideline increases risk of death or serious injury.

4.5 Installation and Cooling Requirements

NOTICE

MOUNTING PRECAUTIONS

Improper mounting can result in overheating and reduced performance. Observe all installation and cooling requirements.

Installation requirements

- Ensure unit stability by mounting vertically to a solid flat surface.
- Ensure that the strength of the mounting location supports the unit weight. Refer to *chapter 3.2 Power Ratings, Weights, and Dimensions*.
- Ensure that the mounting location allows access to open the enclosure door. See *chapter 10.9 Enclosure Dimensions*.
- Ensure that there is adequate space around the unit for cooling airflow.
- Place the unit as near to the motor as possible. Keep the motor cables as short as possible. See *chapter 10.5 Cable Specifications*.
- Ensure the location allows for cable entry at the bottom of the unit.

Cooling and airflow requirements

- Ensure that top and bottom clearance for air cooling is provided. Clearance requirement: 225 mm (9 in).
- Consider derating for temperatures starting between 45 °C (113 °F) and 50 °C (122 °F) and elevation 1000 m (3300 ft) above sea level. See the product-specific *design guide* for detailed information.

The drive uses back-channel cooling to circulate the heat sink cooling air. The cooling duct carries approximately 90% of the heat out of the back channel of the drive. Redirect the back-channel air from the panel or room by using:

- Duct cooling. Back-channel cooling kits are available to direct the air away from the panel when an IP20/chassis drive is installed in a Rittal enclosure. Use of a kit reduces the heat in the panel and smaller door fans can be specified on the enclosure.
- Cooling out the back (top and base covers). The back-channel cooling air can be ventilated out of the room so that the heat from the back channel is not dissipated into the control room.

NOTICE

One or more door fans are required on the enclosure to remove heat not contained in the back channel of the drive. The fans also remove any additional losses generated by other components inside the drive.

Ensure that the fans supply adequate airflow over the heat sink. To select the appropriate number of fans, calculate the total required airflow. The flow rate is shown in *Table 4.2*.

Enclosure size	Door fan/top fan	Heat sink fan
J8	102 m ³ /hr (60 CFM)	420 m ³ /hr (250 CFM)
J9	204 m ³ /hr (120 CFM)	840 m ³ /hr (500 CFM)

Table 4.2 Airflow

4.6 Lifting the Drive

Always lift the drive using the dedicated eye bolts at the top of the drive. See *Illustration 4.2*.

⚠ WARNING

HEAVY LOAD

Unbalanced loads can fall or tip over. Failure to take proper lifting precautions increases risk of death, serious injury, or equipment damage.

- Move the unit using a hoist, crane, forklift, or other lifting device with the appropriate weight rating. See *chapter 3.2 Power Ratings, Weights, and Dimensions* for the weight of the drive.
- Failure to locate the center of gravity and correctly position the load can cause unexpected shifting during lifting and transport. For measurements and center of gravity, see *chapter 10.9 Enclosure Dimensions*.
- The angle from the top of the drive module to the lifting cables affects the maximum load force on the cable. This angle must be 65° or greater. Refer to *Illustration 4.2*. Attach and dimension the lifting cables properly.
- Never walk under suspended loads.
- To guard against injury, wear personal protective equipment such as gloves, safety glasses, and safety shoes.

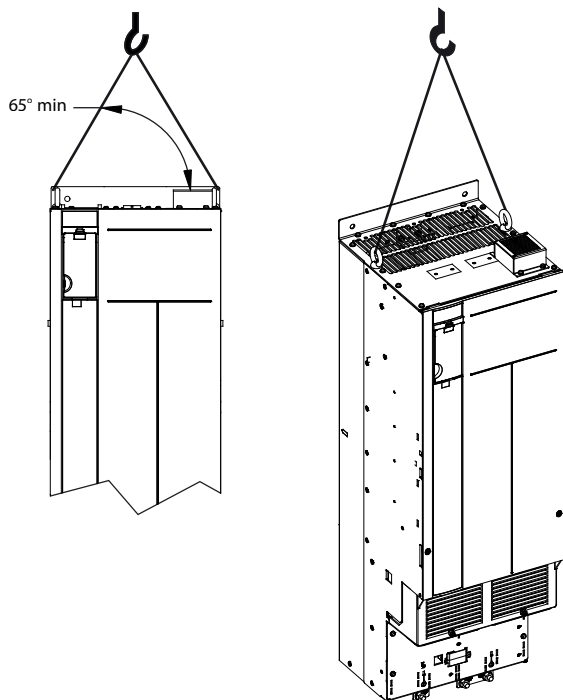

Illustration 4.2 Lifting the Drive

4.7 Mounting the Drive

Wall mounting

J8 and J9 are chassis drives intended to be mounted on a wall or on a mounting plate within an enclosure. To wall mount a drive, use the following steps. Refer to *Illustration 4.3*.

1. Fasten 2 M10 bolts in the wall to align with the fastener slots at the bottom of drive.
2. Slide the lower fastener slots in the drive over the M10 bolts.
3. Tip the drive against the wall, and secure the top with 2 M10 bolts in the mounting holes.

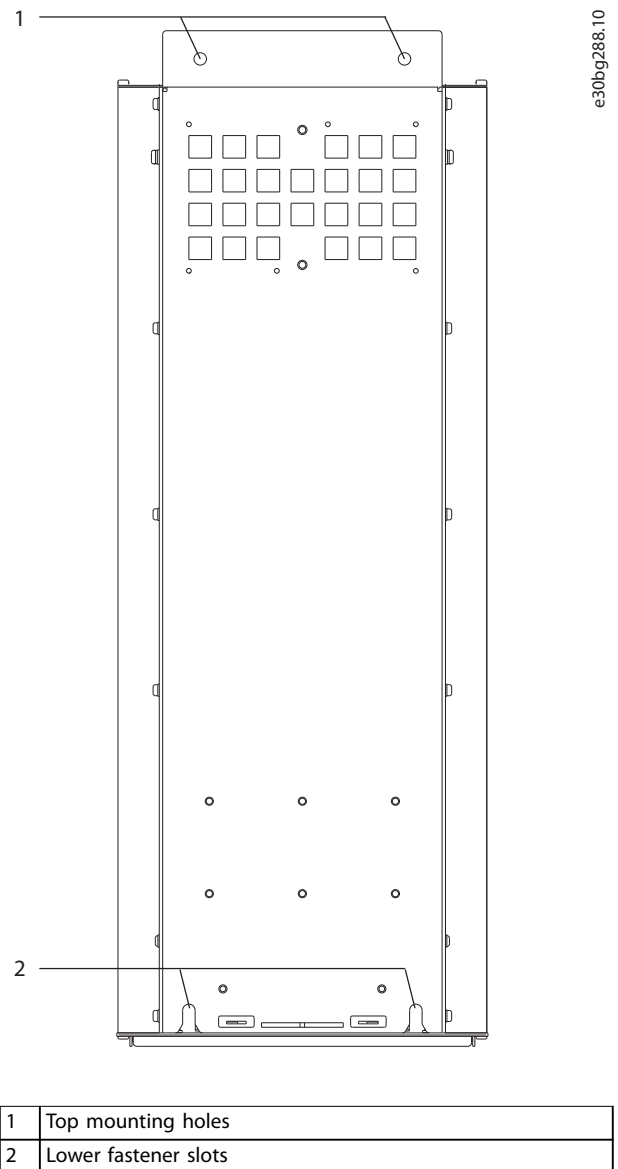

Illustration 4.3 Drive-to-wall Mounting Holes

Creating cable openings

After installing the drive, create cable openings in the gland plate to accommodate the mains and motor cables.

The gland plate is required to maintain the drive protection rating.

- Punch out plastic tabs to accommodate the cables. See *Illustration 4.4*.

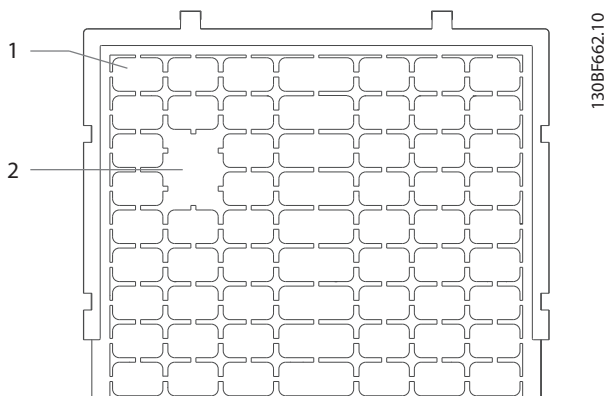

1	Plastic tabs
2	Tabs removed for cable access

Illustration 4.4 Cable Openings in Plastic Gland Plate

5 Electrical Installation

5.1 Safety Instructions

See *chapter 2 Safety* for general safety instructions.

⚠ WARNING

INDUCED VOLTAGE

Induced voltage from output motor cables from different drives that are run together can charge equipment capacitors even with the equipment turned off and locked out. Failure to run output motor cables separately or use shielded cables could result in death or serious injury.

- Run output motor cables separately or use shielded cables.
- Simultaneously lock out all the drives.

⚠ WARNING

SHOCK HAZARD

The drive can cause a DC current in the ground conductor and thus result in death or serious injury.

- When a residual current-operated protective device (RCD) is used for protection against electrical shock, only an RCD of Type B is allowed on the supply side.

Failure to follow the recommendation means that the RCD cannot provide the intended protection.

Overcurrent protection

- Additional protective equipment such as short-circuit protection or motor thermal protection between drive and motor is required for applications with multiple motors.
- Input fusing is required to provide short circuit and overcurrent protection. If fuses are not factory-supplied, the installer must provide them. See maximum fuse ratings in *chapter 10.7 Fuses and Circuit Breakers*.

Wire type and ratings

- All wiring must comply with local and national regulations regarding cross-section and ambient temperature requirements.
- Power connection wire recommendation: Minimum 75 °C (167 °F) rated copper wire.

See *chapter 10.5 Cable Specifications* for recommended wire sizes and types.

⚠ CAUTION

PROPERTY DAMAGE

Protection against motor overload is not included in the default setting. To add this function, set *parameter 1-90 Motor Thermal Protection* to [ETR trip] or [ETR warning]. For the North American market, the ETR function provides class 20 motor overload protection in accordance with NEC. Failure to set *parameter 1-90 Motor Thermal Protection* to [ETR trip] or [ETR warning] means that motor overload protection is not provided and, if the motor overheats, property damage can occur.

5.2 EMC-compliant Installation

To obtain an EMC-compliant installation, follow the instructions provided in:

- *Chapter 5.3 Wiring Schematic*.
- *Chapter 5.4 Connecting to Ground*.
- *Chapter 5.5 Connecting the Motor*.
- *Chapter 5.6 Connecting the AC Mains*.

NOTICE

TWISTED SHIELD ENDS (PIGTAILS)

Twisted shield ends (pigtailed) increase the shield impedance at higher frequencies, reducing the shield effect and increasing the leakage current. To avoid twisted shield ends, use integrated shield clamps.

- For use with relays, control cables, a signal interface, or fieldbus, connect the shield to the enclosure at both ends. If the ground path has high impedance, is noisy, or is carrying current, break the shield connection on 1 end to avoid ground current loops.
- Convey the currents back to the unit using a metal mounting plate. Ensure good electrical contact from the mounting plate through the mounting screws to the drive chassis.
- Use shielded cables for motor output cables. An alternative is unshielded motor cables within metal conduit.

NOTICE

SHIELDED CABLES

If shielded cables or metal conduits are not used, the unit and the installation do not meet regulatory limits on radio frequency (RF) emission levels.

- Avoid placing cables with a sensitive signal level alongside motor.
- For communication and command/control lines, follow the particular communication protocol standards. Danfoss recommends use of shielded cables.
- Ensure that all control terminal connections are PELV.

NOTICE**EMC INTERFERENCE**

Use separate shielded cables for motor and control wiring, and separate cables for mains wiring, motor wiring, and control wiring. Failure to isolate power, motor, and control cables can result in unintended behavior or reduced performance. Minimum 200 mm (7.9 in) clearance between mains, motor, and control cables is required.

NOTICE**INSTALLATION AT HIGH ALTITUDE**

There is a risk of overvoltage. Isolation between components and critical parts could be insufficient, and not comply with PELV requirements. Reduce the risk of overvoltage by using external protective devices or galvanic isolation.

For installations above 2000 m (6500 ft) altitude, contact Danfoss regarding PELV compliance.

NOTICE**PELV COMPLIANCE**

Prevent electric shock by using protective extra low voltage (PELV) electrical supply and complying with local and national PELV regulations.

5

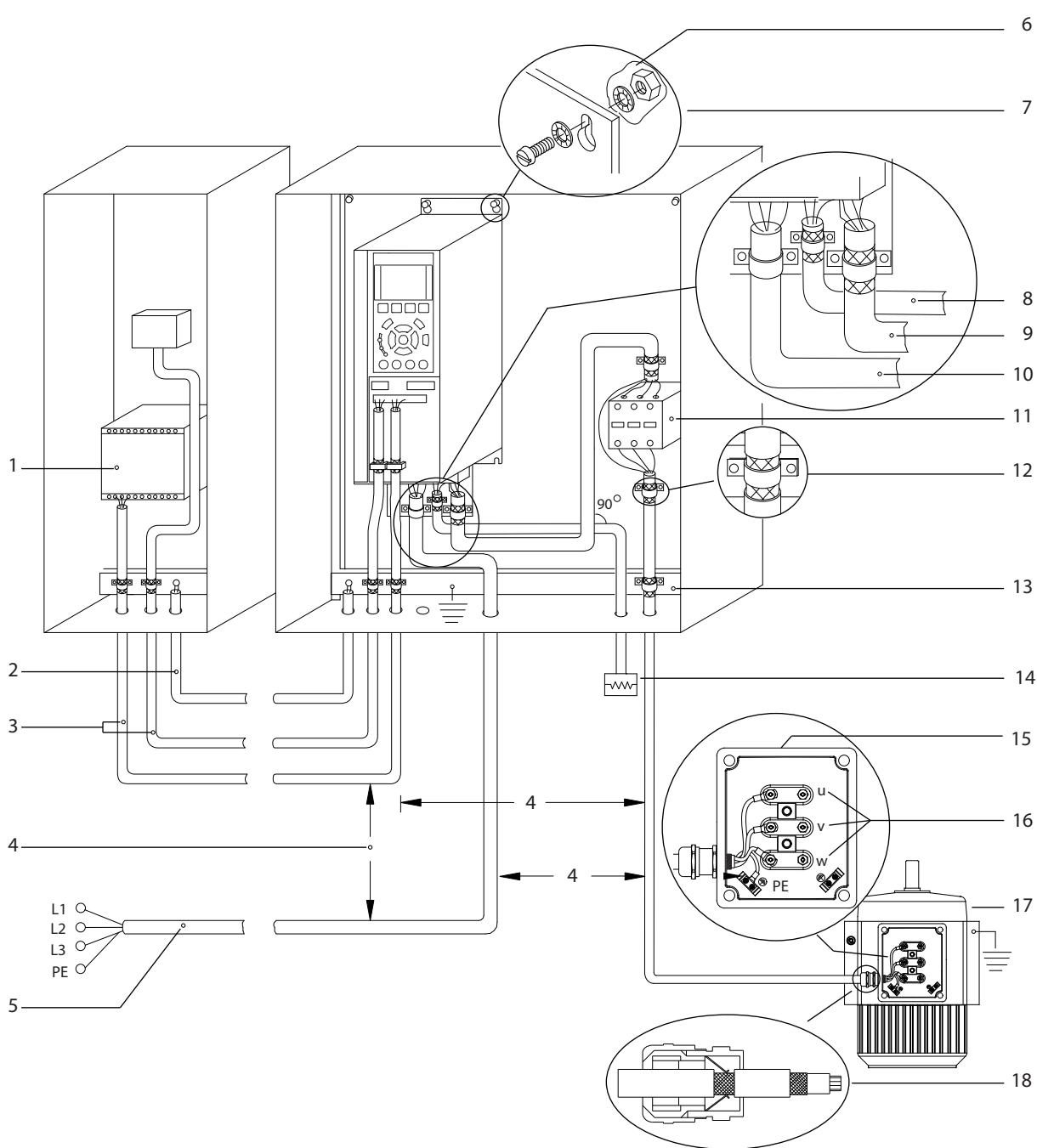

e30bf228.11

1	PLC	10	Mains cable (unshielded)
2	Minimum 16 mm ² (6 AWG) equalizing cable	11	Output contactor and similar options
3	Control cables	12	Cable insulation stripped
4	Required minimum separation of 200 mm (7.9 in) between control cables, motor cables, and mains cables	13	Common ground busbar (follow local and national requirements for enclosure grounding)
5	Mains supply	14	Brake resistor
6	Bare (unpainted) surface	15	Metal box
7	Star washers	16	Connection to motor
8	Brake cable (shielded)	17	Motor
9	Motor cable (shielded)	18	EMC cable gland

Illustration 5.1 Example of Proper EMC Installation

5.3 Wiring Schematic

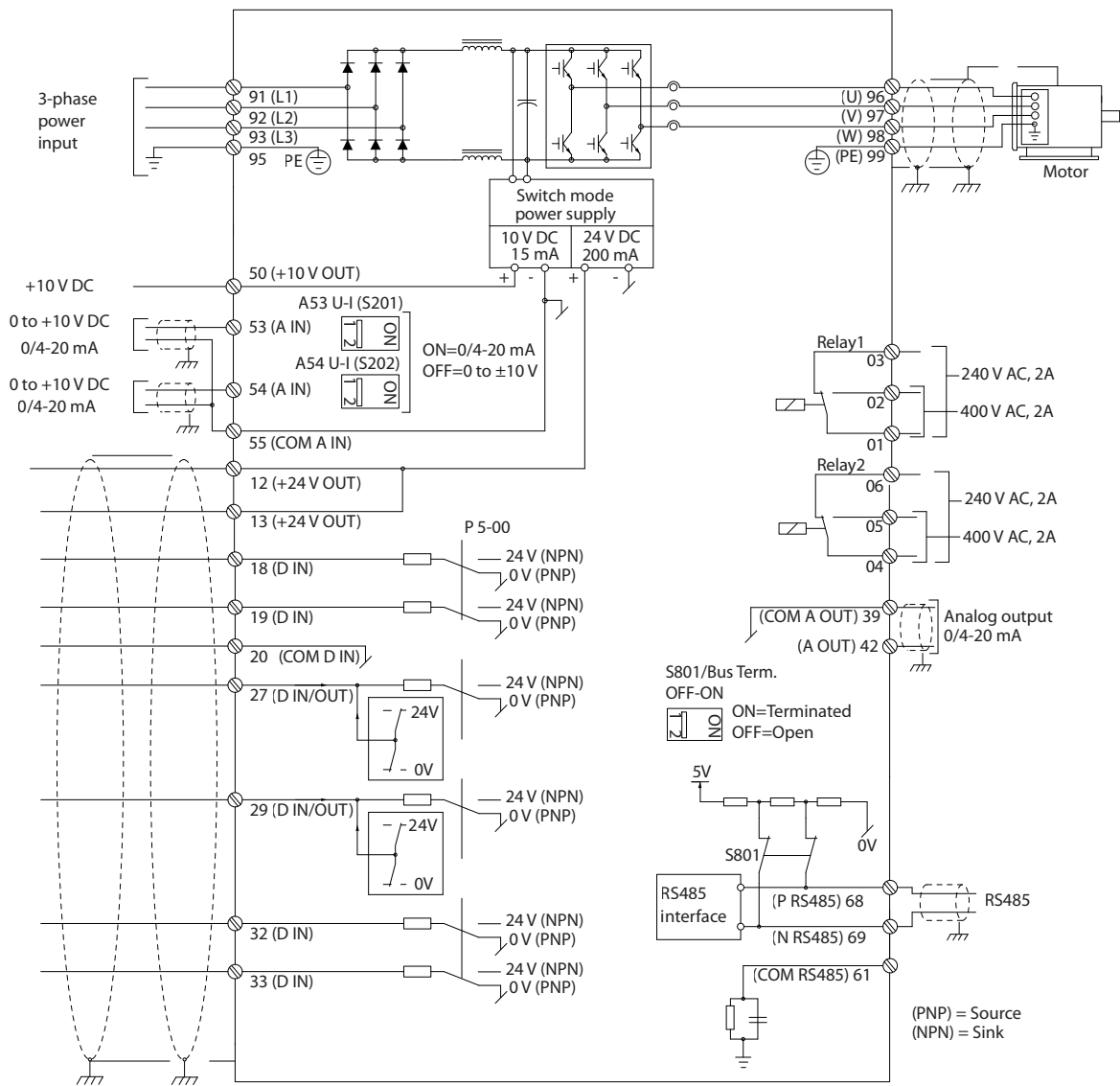

e30bg500.12

Illustration 5.2 Basic Wiring Schematic

5.4 Connecting to Ground

⚠ WARNING

LEAKAGE CURRENT HAZARD

Leakage currents exceed 3.5 mA. Failure to ground the drive properly can result in death or serious injury.

- Ensure the correct grounding of the equipment by a certified electrical installer.

For electrical safety

- Ground the drive in accordance with applicable standards and directives.
- Use a dedicated ground wire for input power, motor power, and control wiring.
- Do not ground 1 drive to another in a daisy chain fashion.
- Keep the ground wire connections as short as possible.
- Follow motor manufacturer wiring requirements.
- Minimum cable cross-section: 10 mm² (6 AWG) (or 2 rated ground wires terminated separately).
- Tighten the terminals in accordance with the information provided in *chapter 10.8 Fastener Tightening Torques*.

For EMC-compliant installation

- Establish electrical contact between the cable shield and the drive enclosure by using metal cable glands or by using the clamps provided on the equipment.
- Reduce burst transient by using high-strand wire.
- Do not use twisted shield ends (pigtailed).

NOTICE

POTENTIAL EQUALIZATION

There is a risk of burst transient when the ground potential between the drive and the control system is different. Install equalizing cables between the system components. Recommended cable cross-section: 16 mm² (5 AWG).

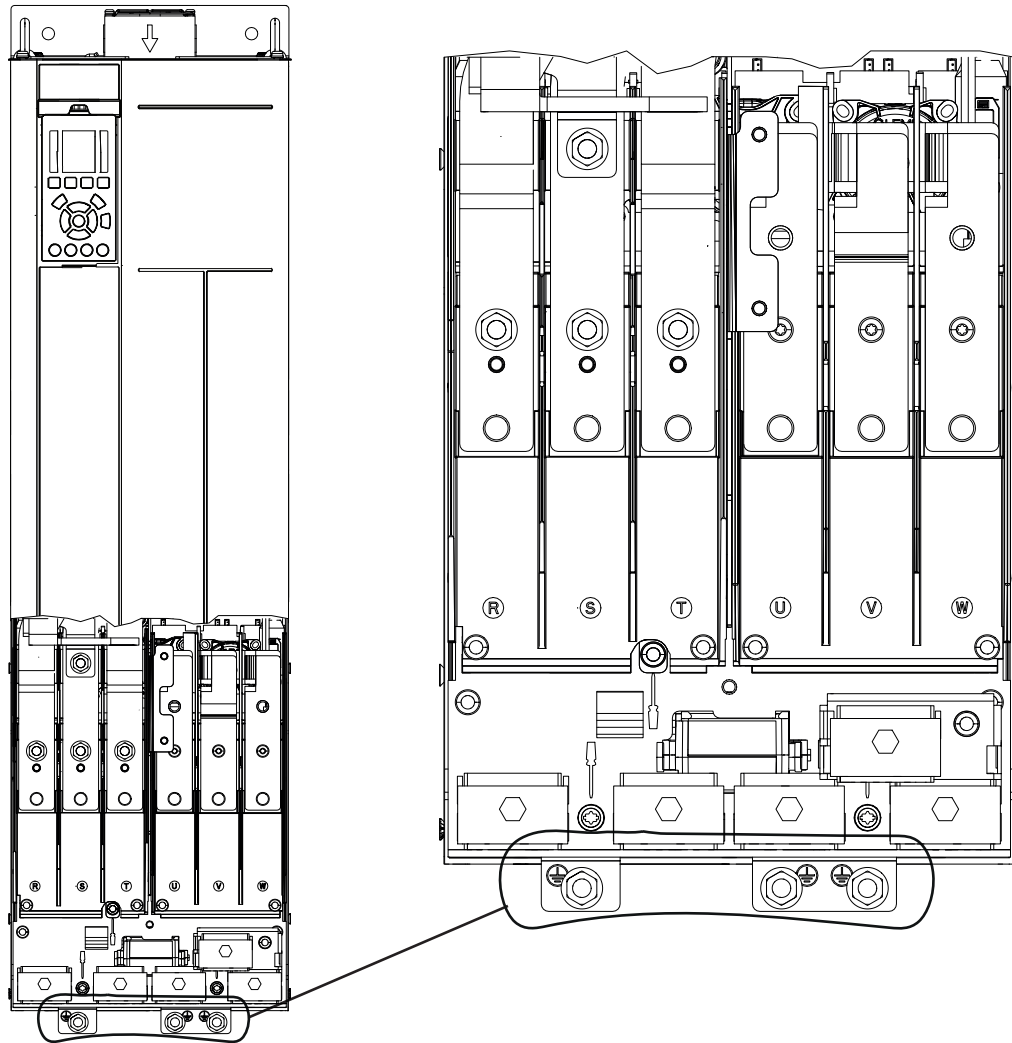

e30b9480.11

5

Illustration 5.3 Ground Terminals (J8 shown)

5.5 Connecting the Motor

⚠ WARNING

INDUCED VOLTAGE

Induced voltage from output motor cables that run together can charge equipment capacitors, even with the equipment turned off and locked out. Failure to run output motor cables separately or use shielded cables could result in death or serious injury.

- Comply with local and national electrical codes for cable sizes. For maximum wire sizes, see *chapter 10.5 Cable Specifications*.
- Follow motor manufacturer wiring requirements.
- Motor wiring knockouts or access panels are provided at the base of IP21 (NEMA1/12) and higher units.
- Do not wire a starting or pole-changing device (for example Dahlander motor or slip ring asynchronous motor) between the drive and the motor.

Procedure

1. Strip a section of the outer cable insulation.
2. Position the stripped wire under the cable clamp, establishing mechanical fixation and electrical contact between the cable shield and ground.
3. Connect the ground wire to the nearest grounding terminal in accordance with the grounding instructions provided in *chapter 5.4 Connecting to Ground*, see *Illustration 5.4*.
4. Connect the 3-phase motor wiring to terminals 96 (U), 97 (V), and 98 (W), see *Illustration 5.4*.
5. Tighten the terminals in accordance with the information provided in *chapter 10.8 Fastener Tightening Torques*.

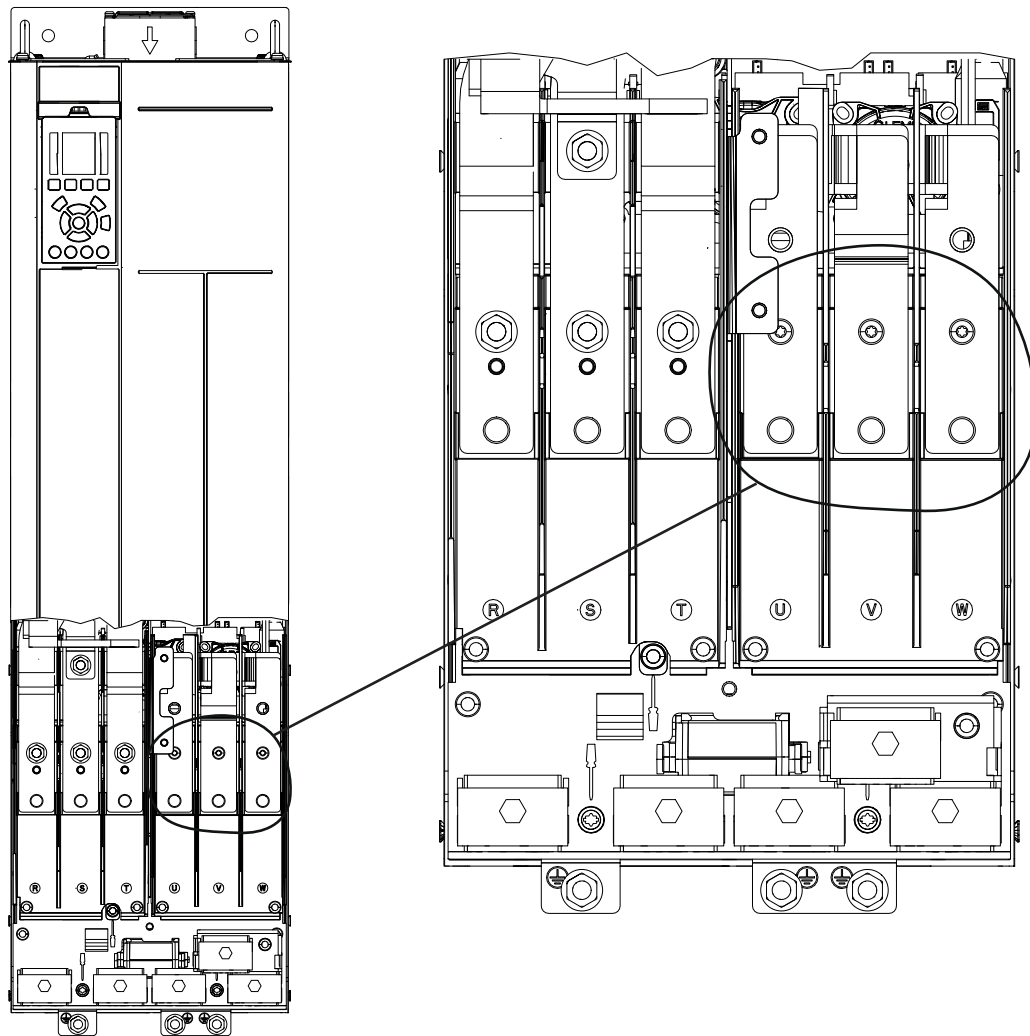

e30b9481.11

5

Illustration 5.4 Motor Terminals (J8 shown)

5.6 Connecting the AC Mains

- Size the wiring according to the input current of the drive. For maximum wire sizes, see *chapter 10.1 Electrical Data, 380-480 V*.
- Comply with local and national electrical codes for cable sizes.

Procedure

1. Strip a section of the outer cable insulation.
2. Position the stripped wire under the cable clamp, establishing mechanical fixation and electrical contact between the cable shield and ground.
3. Connect the ground wire to the nearest grounding terminal in accordance with the grounding instructions provided in *chapter 5.4 Connecting to Ground*.
4. Connect the 3-phase AC input power wiring to terminals R, S, and T (see *Illustration 5.5*).
5. When supplied from an isolated mains source (IT mains or floating delta) or TT/TN-S mains with a grounded leg (grounded delta), ensure that *parameter 14-50 RFI Filter* is set to [0] Off to avoid damage to the DC link and to reduce ground capacity currents.
6. Tighten the terminals in accordance with the information provided in *chapter 10.8 Fastener Tightening Torques*.

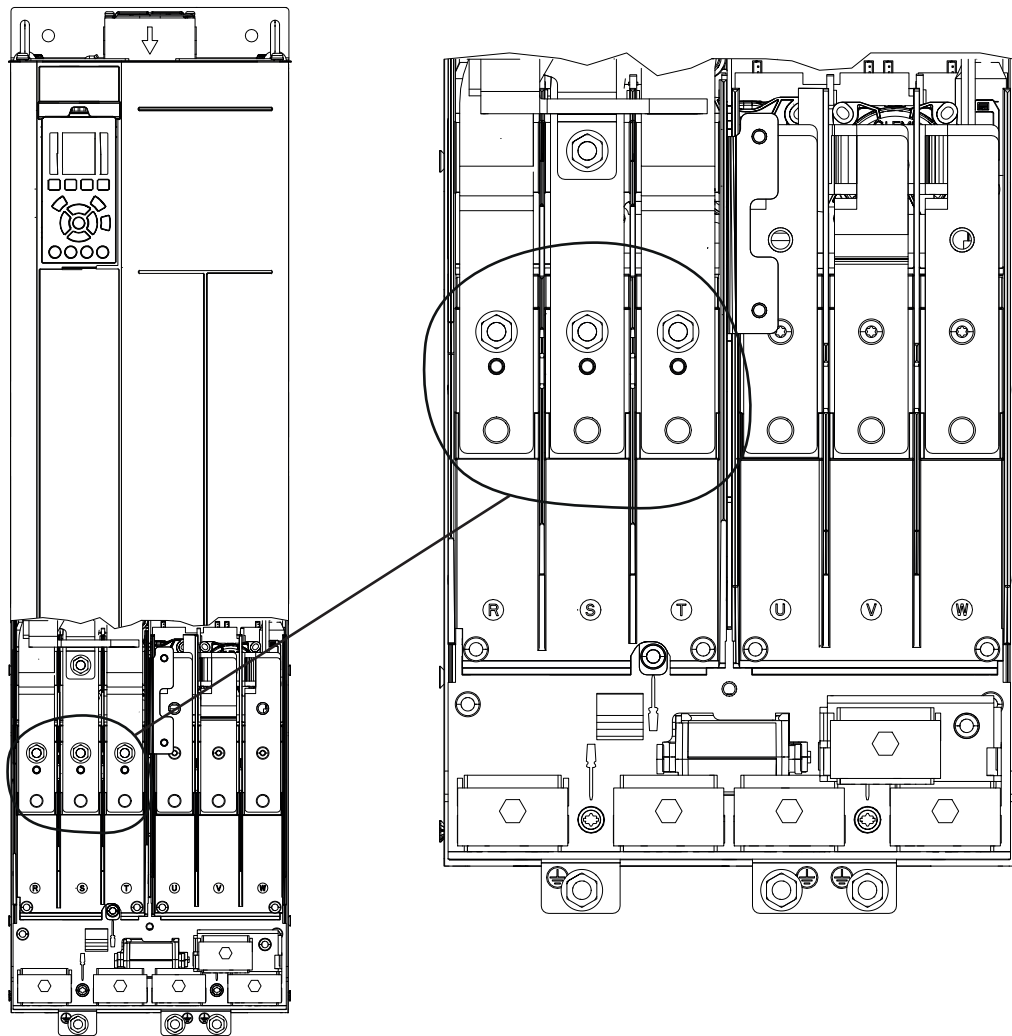

e30b9482.11

5

Illustration 5.5 AC Mains Terminals (J8 shown). For a detailed view of terminals, see *chapter 5.7 Terminal Dimensions*.

5.7 Terminal Dimensions

5.7.1 J8 Terminal Dimensions

5

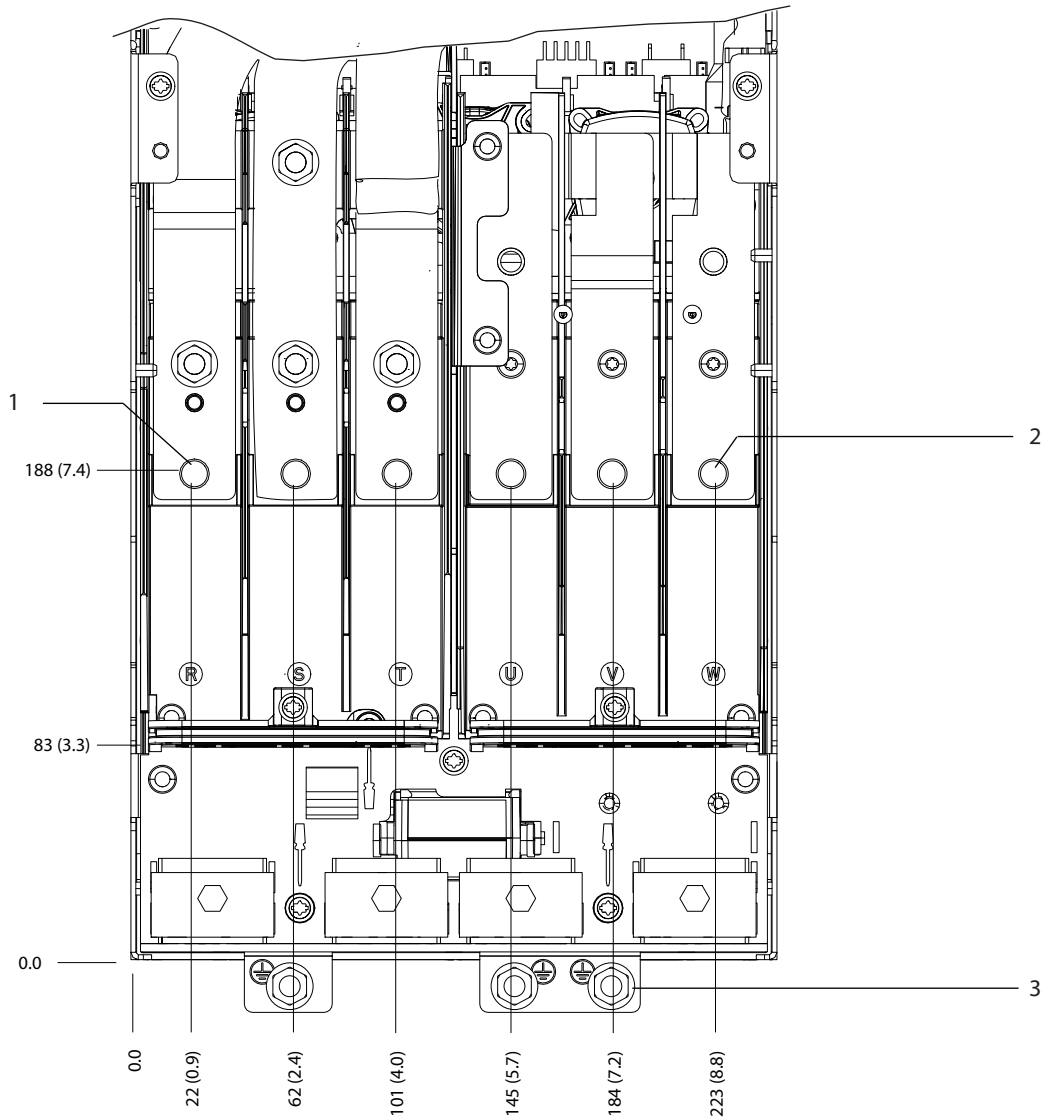

e30bg615:10

1	Mains terminals	3	Ground terminals
2	Motor terminals	-	-

Illustration 5.6 J8 Terminal Dimensions (Front View)

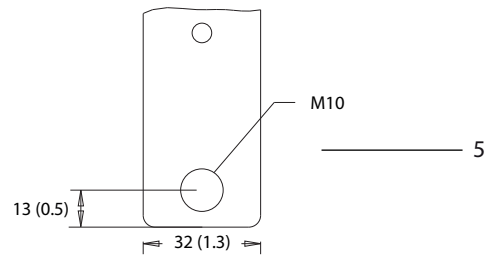
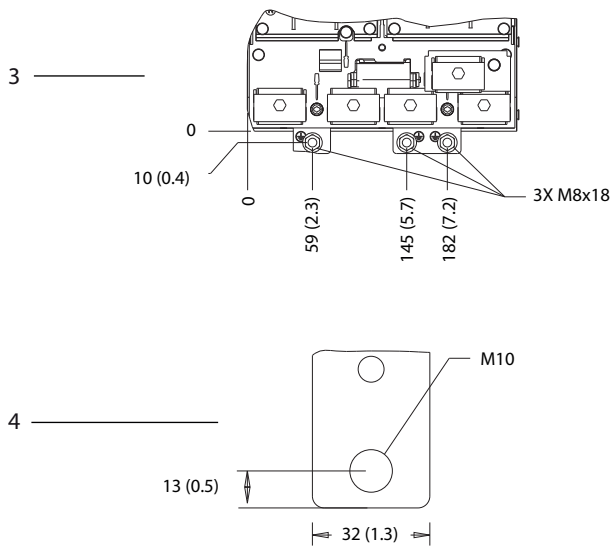
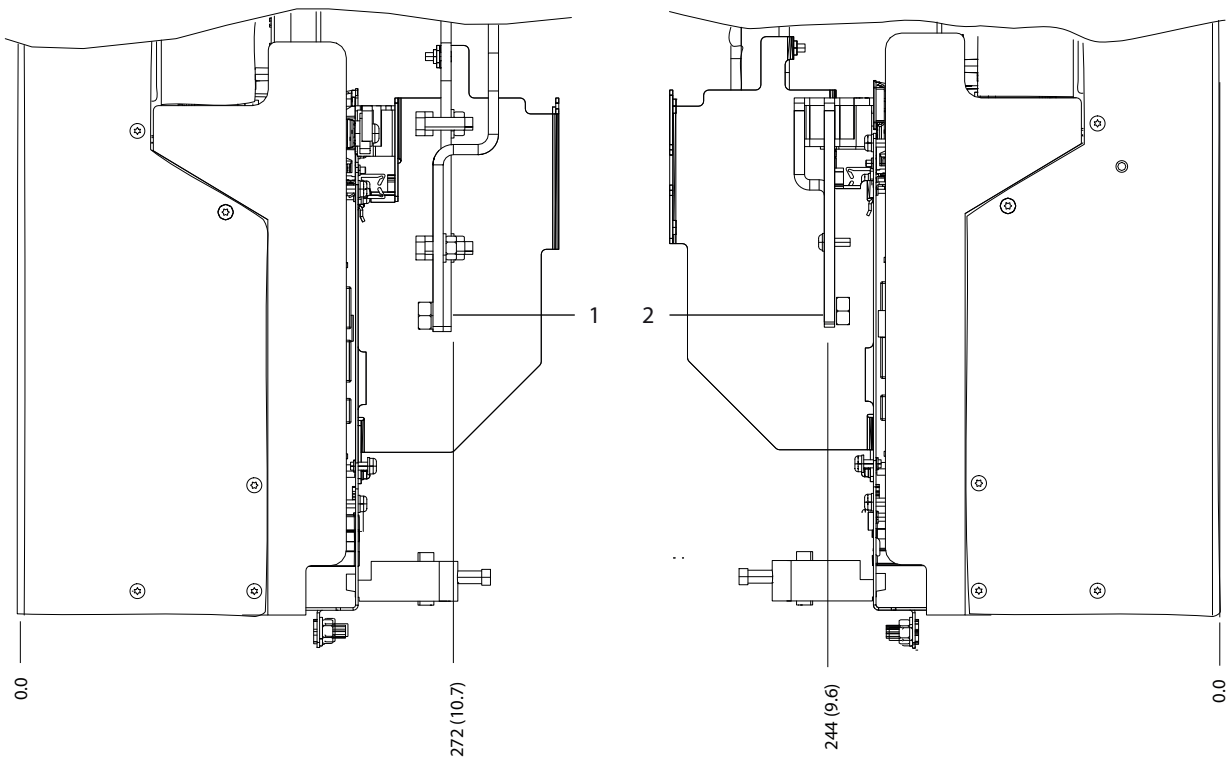

1 and 4	Mains terminals	2 and 5	Motor terminals
3	Ground terminals	-	-

Illustration 5.7 J8 Terminal Dimensions (Side Views)

5.7.2 J9 Terminal Dimensions

5

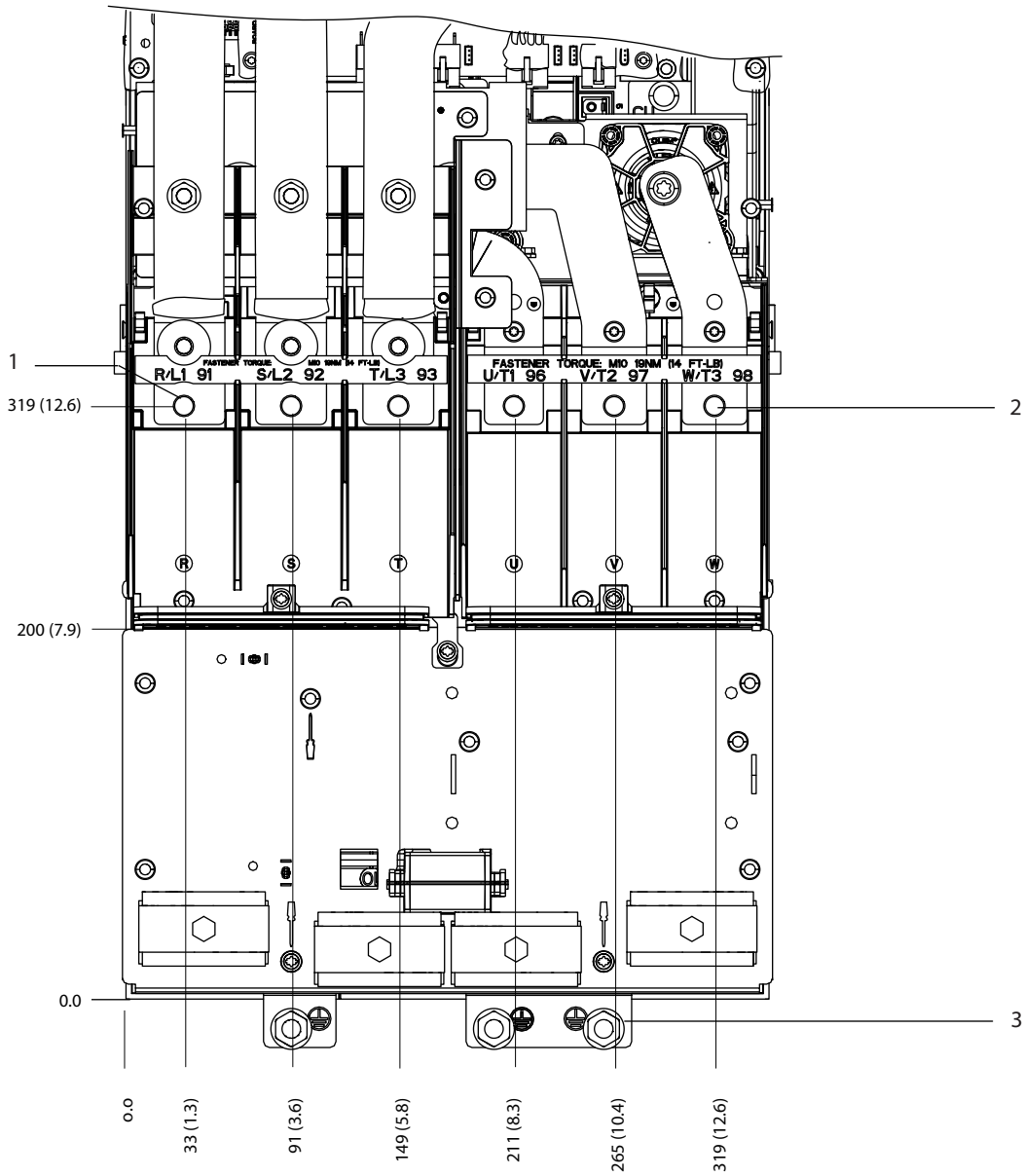

e30b9616.10

1	Mains terminals	3	Ground terminals
2	Motor terminals	-	-

Illustration 5.8 J9 Terminal Dimensions (Front View)

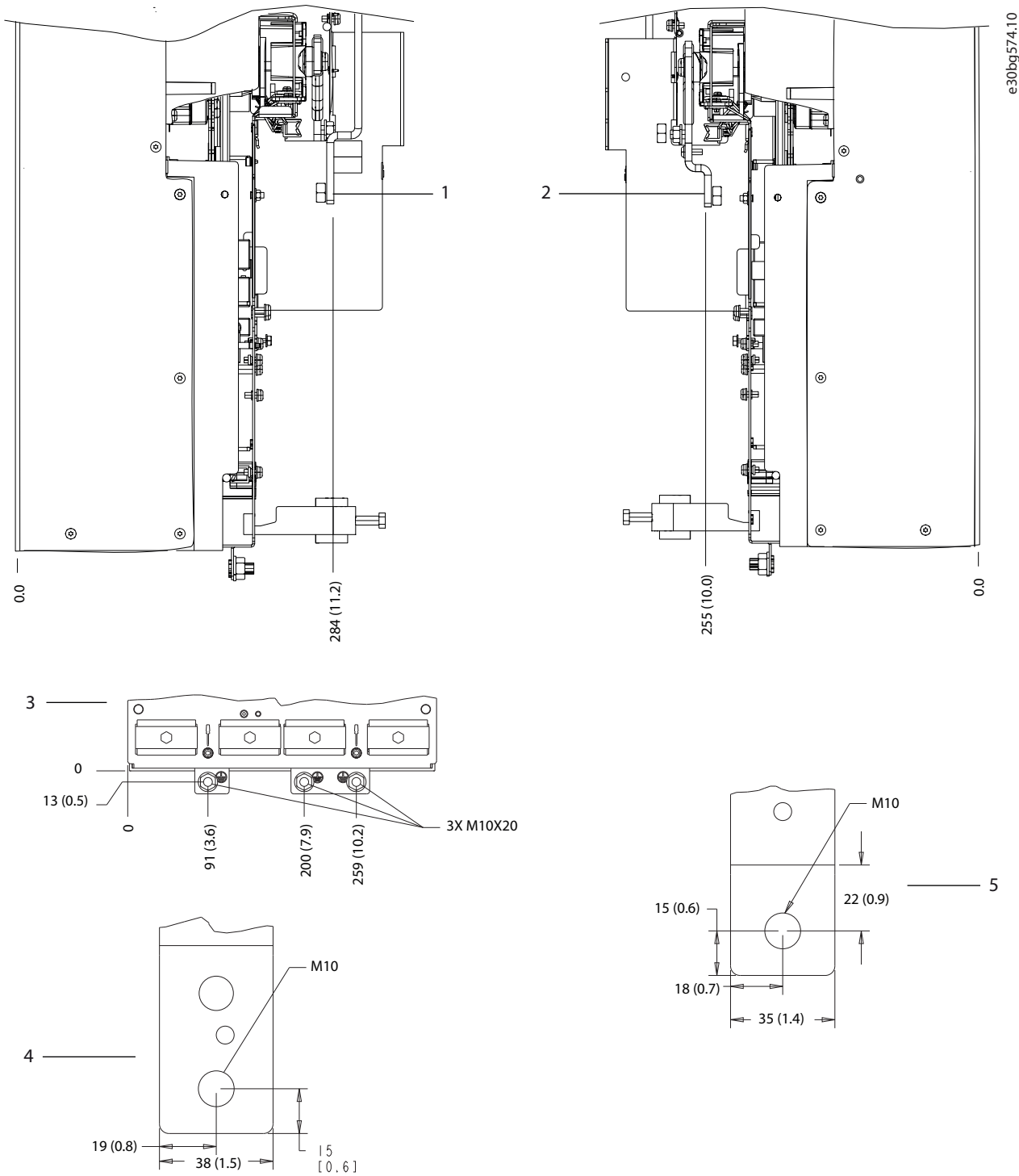

e30bg574.10

5

1 and 4	Mains terminals	2 and 5	Motor terminals
3	Ground terminals	-	-

Illustration 5.9 J9 Terminal Dimensions (Side Views)

5.8 Control Wiring

All terminals to the control cables are inside the drive below the LCP. To access the control terminals, remove the front panel.

5.8.1 Control Cable Routing

- Isolate control wiring from high-power components in the drive.
- Tie down all control wires after routing them.
- Connect shields to ensure optimum electrical immunity.
- When the drive is connected to a thermistor, ensure that the thermistor control wiring is shielded and reinforced/double insulated. A 24 V DC supply voltage is recommended.

Fieldbus connection

Connections are made to the relevant options on the control card. For more detail, see the relevant fieldbus instruction. The cable must be tied down and routed along with other control wires inside the unit.

5.8.2 Control Terminal Types

Illustration 5.10 shows the removable drive connectors. Terminal functions and default settings are summarized in Table 5.1 – Table 5.3.

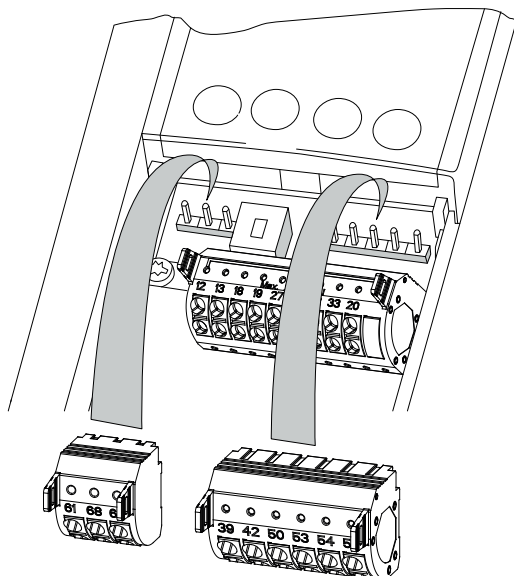
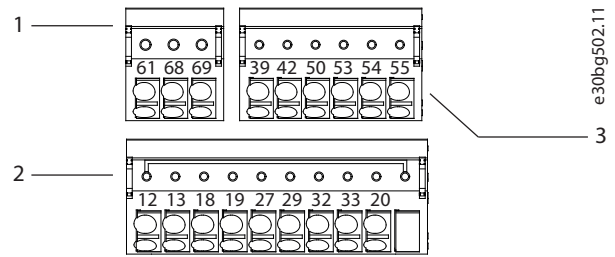

Illustration 5.10 Control Terminal Locations



1	Serial communication terminals
2	Digital input/output terminals
3	Analog input/output terminals

Illustration 5.11 Terminal Numbers Located on the Connectors

Serial communication terminals			
Terminal	Parameter	Default setting	Description
61	–	–	Integrated RC-filter for cable shield. ONLY for connecting the shield in the event of EMC problems.
68 (+)	Parameter group 8-3* FC Port Settings	–	RS485 interface. A switch (BUS TER.) is provided on the control card for bus termination resistance. See Illustration 5.16.
69 (-)	Parameter group 8-3* FC Port Settings	–	
Relays			
01, 02, 03	Parameter 5-40 Function Relay [0]	[0] No operation	Form C relay output. For AC or DC voltage and resistive or inductive loads.
04, 05, 06	Parameter 5-40 Function Relay [1]	[0] No operation	

Table 5.1 Serial Communication Terminal Descriptions

Digital input/output terminals			
Terminal	Parameter	Default setting	Description
12, 13	–	+24 V DC	24 V DC supply voltage for digital inputs and external transducers. Maximum output current 200 mA for all 24 V loads.
18	Parameter 5-10 Terminal 18 Digital Input	[8] Start	Digital inputs.
19	Parameter 5-11 Terminal 19 Digital Input	[10] Reversing	
32	Parameter 5-14 Terminal 32 Digital Input	[0] No operation	
33	Parameter 5-15 Terminal 33 Digital Input	[0] No operation	
27	Parameter 5-12 Terminal 27 Digital Input	[2] Coast inverse	
29	Parameter 5-13 Terminal 29 Digital Input	[14] JOG	
20	–	–	Common for digital inputs and 0 V potential for 24 V supply.

Table 5.2 Digital Input/Output Terminal Descriptions

Analog input/output terminals			
Terminal	Parameter	Default setting	Description
39	–	–	Common for analog output.
42	Parameter 6-50 Terminal 42 Output	[0] No operation	Programmable analog output. 0–20 mA or 4–20 mA at a maximum of 500 Ω.
50	–	+10 V DC	10 V DC analog supply voltage for potentiometer or thermistor. 15 mA maximum.
53	Parameter group 6-1* Analog Input 1	Reference	Analog input. For voltage or current. Switches A53 and A54 select mA or V.
54	Parameter group 6-2* Analog Input 2	Feedback	
55	–	–	Common for analog input.

Table 5.3 Analog Input/Output Terminal Descriptions

Relay terminals:

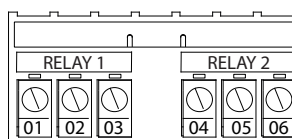

130BF156.10

Illustration 5.12 Relay 1 and Relay 2 Terminals

- Relay 1 and relay 2. The location of the outputs depends on the drive configuration. See chapter 3.5 View of Control Shelf.
- Terminals on built-in optional equipment. See the manual provided with the equipment option.

5.8.3 Wiring to Control Terminals

The control terminals are located near the LCP. The control terminal connectors can be unplugged from the drive for convenience when wiring, as shown in *Illustration 5.10*. Either solid or flexible wire can be connected to the control terminals. Use the following procedures to connect or disconnect the control wires.

NOTICE

Minimize interference by keeping control wires as short as possible and separate from high-power cables.

5

Connecting wire to control terminals

1. Strip 10 mm (0.4 in) of the outer plastic layer from the end of the wire.
2. Insert the control wire into the terminal.
 - For a solid wire, push the bare wire into the contact. See *Illustration 5.13*.
 - For a flexible wire, open the contact by inserting a small screwdriver into the slot between the terminal holes and push the screwdriver inward. See *Illustration 5.14*. Then, insert the stripped wire into the contact, and remove the screwdriver.
3. Pull gently on the wire to ensure that the contact is firmly established. Loose control wiring can be the source of equipment faults or reduced performance.

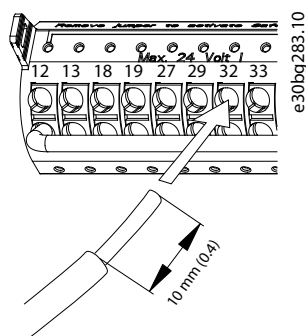

Illustration 5.13 Connecting Solid Control Wires

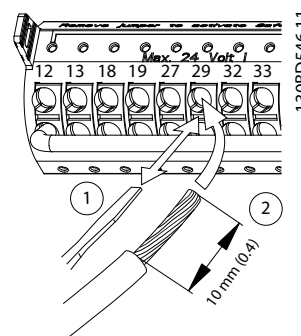

Illustration 5.14 Connecting Flexible Control Wires

Disconnecting wires from the control terminals

1. To open the contact, insert a small screwdriver into the slot between the terminal holes and push the screwdriver inward.
2. Pull gently on the wire to free it from the control terminal contact.

See *chapter 10.5 Cable Specifications* for control terminal wiring sizes and *chapter 8 Wiring Configuration Examples* for typical control wiring connections.

5.8.4 Enabling Motor Operation (Terminal 27)

A jumper wire is required between terminal 12 (or 13) and terminal 27 for the drive to operate when using factory default programming values.

- Digital input terminal 27 is designed to receive 24 V DC external interlock command.
- When no interlock device is used, wire a jumper between control terminal 12 (recommended) or 13 to terminal 27. This wire provides an internal 24 V signal on terminal 27.
- When the status line at the bottom of the LCP reads *AUTO REMOTE COAST*, the unit is ready to operate, but is missing an input signal on terminal 27.
- When factory-installed optional equipment is wired to terminal 27, do not remove that wiring.

NOTICE

The drive cannot operate without a signal on terminal 27, unless terminal 27 is reprogrammed using *parameter 5-12 Terminal 27 Digital Input*.

5.8.5 Configuring RS485 Serial Communication

RS485 is a 2-wire bus interface compatible with multi-drop network topology, and it contains the following features:

- Either Danfoss FC or Modbus RTU communication protocol, which are internal to the drive, can be used.
- Functions can be programmed remotely using the protocol software and RS485 connection or in *parameter group 8-** Communications and Options*.
- Selecting a specific communication protocol changes various default parameter settings to match the specifications of the protocol, making more protocol-specific parameters available.
- Option cards for the drive are available to provide more communication protocols. See the option card documentation for installation and operation instructions.
- A switch (BUS TER) is provided on the control card for bus termination resistance. See *Illustration 5.16*.

For basic serial communication set-up, perform the following steps:

1. Connect RS485 serial communication wiring to terminals (+)68 and (-)69.
 - 1a Use shielded serial communication cable (recommended).
 - 1b See *chapter 5.4 Connecting to Ground* for proper grounding.
2. Select the following parameter settings:
 - 2a Protocol type in *parameter 8-30 Protocol*.
 - 2b Drive address in *parameter 8-31 Address*.
 - 2c Baud rate in *parameter 8-32 Baud Rate*.

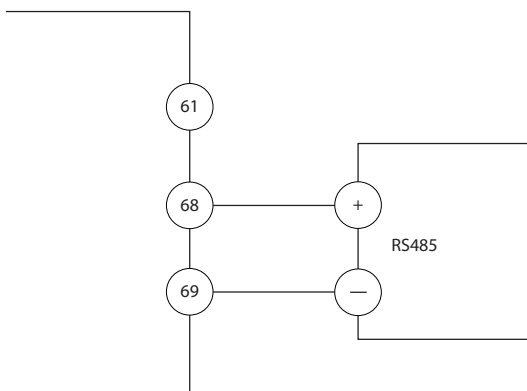

Illustration 5.15 Serial Communication Wiring Diagram

130BB489.10

5.8.6 Selecting Voltage/Current Input Signal

The analog input terminals 53 and 54 allow setting of input signal to voltage (0–10 V) or current (0/4–20 mA).

Default parameter setting:

- Terminal 53: Speed reference signal in open loop (see *parameter 16-61 Terminal 53 Switch Setting*).
- Terminal 54: Feedback signal in closed loop (see *parameter 16-63 Terminal 54 Switch Setting*).

NOTICE

Disconnect power to the drive before changing switch positions.

1. Remove the LCP. See *Illustration 5.16*.
2. Remove any optional equipment covering the switches.
3. Set switches A53 and A54 to select the signal type (U = voltage, I = current).

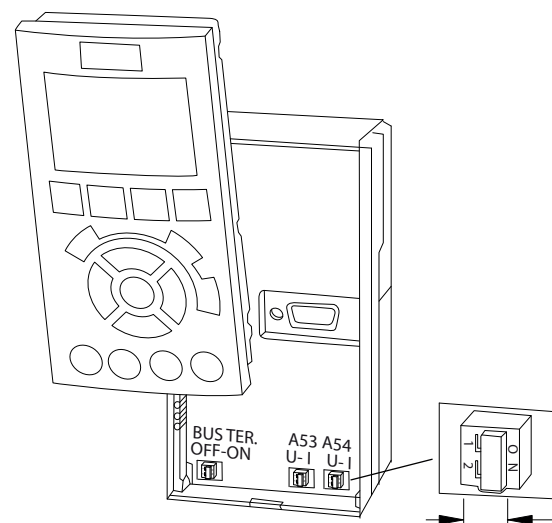

130BF146.10

Illustration 5.16 Location of Terminal 53 and 54 Switches

6 Pre-start Check List

Before completing installation of the unit, inspect the entire installation as detailed in *Table 6.1*. Check and mark the items when completed.

Inspect for	Description	<input checked="" type="checkbox"/>
Motor	<ul style="list-style-type: none"> Confirm continuity of the motor by measuring ohm values on U–V (96–97), V–W (97–98), and W– U (98–96). Confirm that the supply voltage matches the voltage of the drive and the motor. 	
Switches	<ul style="list-style-type: none"> Ensure that all switch and disconnect settings are in the proper positions. 	
Auxiliary equipment	<ul style="list-style-type: none"> Look for auxiliary equipment, switches, disconnects, or input fuses/circuit breakers that reside on the input power side of the drive or output side to the motor. Ensure that they are ready for full-speed operation. Check function and installation of any sensors used for feedback to the drive. Remove any power factor correction caps on motor. Adjust any power factor correction caps on the mains side and ensure that they are dampened. 	
Cable routing	<ul style="list-style-type: none"> Ensure that motor wiring, brake wiring (if equipped), and control wiring are separated or shielded, or in 3 separate metallic conduits for high-frequency interference isolation. 	
Control wiring	<ul style="list-style-type: none"> Check for broken or damaged wires and loose connections. Check that control wiring is isolated from high-power wiring for noise immunity. Check the voltage source of the signals, if necessary. Use shielded cable or twisted pair and ensure that the shield is terminated correctly. 	
Input and output power wiring	<ul style="list-style-type: none"> Check for loose connections. Check that motor and mains are in separate conduit or separated shielded cables. 	
Grounding	<ul style="list-style-type: none"> Check for good ground connections that are tight and free of oxidation. Grounding to conduit, or mounting the back panel to a metal surface, is not a suitable grounding. 	
Fuses and circuit breakers	<ul style="list-style-type: none"> Check for proper fusing or circuit breakers. Check that all fuses are inserted firmly and are in operational condition and that all circuit breakers (if used) are in the open position. 	
Cooling clearance	<ul style="list-style-type: none"> Look for any obstructions in the airflow path. Measure top and bottom clearance of the drive to verify adequate airflow for cooling, see <i>chapter 4.5 Installation and Cooling Requirements</i>. 	
Ambient conditions	<ul style="list-style-type: none"> Check that requirements for ambient conditions are met. See <i>chapter 10.4 Ambient Conditions</i>. 	
Interior of Drive	<ul style="list-style-type: none"> Inspect that the unit interior is free of dirt, metal chips, moisture, and corrosion. Verify that all installation tools have been removed from unit interior. Ensure that the unit is mounted on an unpainted, metal surface. 	
Vibration	<ul style="list-style-type: none"> Check that the unit is mounted solidly, or that shock mounts are used, if necessary. Check for an unusual amount of vibration. 	

Table 6.1 Pre-start Check List

7 Commissioning

7.1 Applying Power

⚠ WARNING

UNINTENDED START

When the drive is connected to AC mains, DC supply, or load sharing, the motor can start at any time, causing risk of death, serious injury, and equipment, or property damage. The motor can start by activation of an external switch, a fieldbus command, an input reference signal from the LCP or LOP, via remote operation using MCT 10 Set-up software, or after a cleared fault.

To prevent unintended motor start:

- Press [Off] on the LCP before programming parameters.
- Disconnect the drive from mains whenever personal safety considerations make it necessary to avoid unintended motor start.
- Check that the drive, motor, and any driven equipment are in operational readiness.

NOTICE

MISSING SIGNAL

If the status at the bottom of the LCP reads **AUTO REMOTE COASTING**, or *alarm 60, External interlock* is shown, it indicates that the unit is ready to operate but is missing an input signal on, for example, terminal 27. See *chapter 5.8.4 Enabling Motor Operation (Terminal 27)*.

Apply power to the drive using the following steps:

1. Confirm that the input voltage is balanced within 3%. If not, correct the input voltage imbalance before proceeding. Repeat this procedure after the voltage correction.
2. Ensure that any optional equipment wiring matches the installation requirements.
3. Ensure that all operator devices are in the OFF position.
4. Close and securely fasten all covers and doors on the drive.
5. Apply power to the unit, but do not start the drive. For units with a disconnect switch, turn the switch to the ON position to apply power to the drive.

7.2 Programming the Drive

7.2.1 Parameter Overview

Parameters contain various settings that are used to configure and operate the drive and motor. These parameter settings are programmed into the local control panel (LCP) through the different LCP menus. For more detail on parameters, see the product-specific *programming guide*.

Parameter settings are assigned a default value at the factory, but can be configured for their unique application. Each parameter has a name and number that remain the same regardless of the programming mode.

In the Main Menu mode, the parameters are divided into groups. The 1st digit of the parameter number (from the left) indicates the parameter group number. The parameter group is then broken down into subgroups, if necessary. For example:

0-** Operation/Display	Parameter group
0-0* Basic Settings	Parameter subgroup
Parameter 0-01 Language	Parameter
Parameter 0-02 Motor Speed Unit	Parameter
Parameter 0-04 Operating State at Power-up (Hand)	Parameter

Table 7.1 Example of Parameter Group Hierarchy

7.2.2 Parameter Navigation

Use the following LCP keys to navigate through the parameters:

- Press [▲] [▼] to scroll up or down.
- Press [◀] [▶] to shift a space to the left or right of a decimal point while editing a decimal parameter value.
- Press [OK] to accept the change.
- Press [Cancel] to disregard the change and exit edit mode.
- Press [Back] twice to show the status view.
- Press [Main Menu] once to go back to the main menu.

7.2.3 Entering System Information

NOTICE

SOFTWARE DOWNLOAD

For commissioning via PC, install MCT 10 Set-up Software. The software is available for download (basic version) or for ordering (advanced version, code number 130B1000). For more information and downloads, see www.danfoss.com/en/service-and-support/downloads/dds/vlt-motion-control-tool-mct-10/.

The following steps are used to enter basic system information into the drive. Recommended parameter settings are intended for start-up and checkout purposes. Application settings vary.

NOTICE

Although these steps assume that an asynchronous motor is used, a permanent magnet motor can be used. For more information on specific motor types, see the product-specific programming guide.

1. Press [Main Menu] on the LCP.
2. Select 0-** Operation/Display and press [OK].
3. Select 0-0* Basic Settings and press [OK].
4. Press [Quick Menus] on the LCP and then select 02 Quick Setup.
5. Change the following parameters settings listed in Table 7.2 if necessary. The motor data is found on the motor nameplate.

Parameter	Default setting
Parameter 0-01 Language	English
Parameter 1-20 Motor Power [kW]	4.00 kW
Parameter 1-22 Motor Voltage	400 V
Parameter 1-23 Motor Frequency	50 Hz
Parameter 1-24 Motor Current	9.00 A
Parameter 1-25 Motor Nominal Speed	1420 RPM
Parameter 5-12 Terminal 27 Digital Input	Coast inverse
Parameter 3-02 Minimum Reference	0.000 RPM
Parameter 3-03 Maximum Reference	1500.000 RPM
Parameter 3-41 Ramp 1 Ramp Up Time	3.00 s
Parameter 3-42 Ramp 1 Ramp Down Time	3.00 s
Parameter 3-13 Reference Site	Linked to Hand/ Auto
Parameter 1-29 Automatic Motor Adaptation (AMA)	Off

Table 7.2 Quick Set-up Settings

NOTICE

MISSING INPUT SIGNAL

When the LCP shows AUTO REMOTE COASTING or alarm 60, External Interlock, the unit is ready to operate but is missing an input signal. See chapter 5.8.4 Enabling Motor Operation (Terminal 27) for details.

7.2.4 Configuring Automatic Energy Optimization

Automatic energy optimization (AEO) is a procedure that minimizes voltage to the motor, reducing energy consumption, heat, and noise.

1. Press [Main Menu].
2. Select 1-** Load and Motor and press [OK].
3. Select 1-0* General Settings and press [OK].
4. Select parameter 1-03 Torque Characteristics and press [OK].
5. Select either [2] Auto Energy Optim CT or [3] Auto Energy Optim VT and press [OK].

7.2.5 Configuring Automatic Motor Adaptation

Automatic motor adaptation is a procedure that optimizes compatibility between the drive and the motor.

The drive builds a mathematical model of the motor for regulating output motor current. The procedure also tests the input phase balance of electrical power. It compares the motor characteristics with the data entered in parameters 1-20 to 1-25.

NOTICE

If warnings or alarms occur, see chapter 9.5 List of Warnings and Alarms. Some motors are unable to run the complete version of the test. In that case, or if an output filter is connected to the motor, select [2] Enable reduced AMA.

Run this procedure on a cold motor for best results.

1. Press [Main Menu].
2. Select 1-** Load and Motor and press [OK].
3. Select 1-2* Motor Data and press [OK].
4. Select parameter 1-29 Automatic Motor Adaptation (AMA) and press [OK].
5. Select [1] Enable complete AMA and press [OK].
6. Press [Hand On] and then [OK].
The test runs automatically and indicates when it is complete.

7.3 Testing Before System Start-up

⚠ WARNING

MOTOR START

Failure to ensure that the motor, system, and any attached equipment are ready for start can result in personal injury or equipment damage. Before start,

- Ensure that equipment is safe to operate under any condition.
- Ensure that the motor, system, and any attached equipment are ready for start.

7.3.1 Motor Rotation

NOTICE

If the motor runs in the wrong direction, it can damage equipment. Before running the unit, check the motor rotation by briefly running the motor. The motor runs briefly at either 5 Hz or the minimum frequency set in *parameter 4-12 Motor Speed Low Limit [Hz]*.

1. Press [Hand On].
2. Move the left cursor to the left of the decimal point by using the left arrow key, and enter an RPM that slowly rotates the motor.
3. Press [OK].
4. If the motor rotation is wrong, set *parameter 1-06 Clockwise Direction* to [1] Inverse.

7.3.2 Encoder Rotation

If encoder feedback is used, perform the following steps:

1. Select [0] Open Loop in *parameter 1-00 Configuration Mode*.
2. Select [1] 24 V encoder in *parameter 7-00 Speed PID Feedback Source*.
3. Press [Hand On].
4. Press [►] for positive speed reference (*parameter 1-06 Clockwise Direction* at [0] Normal).
5. In *parameter 16-57 Feedback [RPM]*, check that the feedback is positive.

For more information on the encoder option, refer to the option manual.

NOTICE

NEGATIVE FEEDBACK

If the feedback is negative, the encoder connection is wrong. Use either *parameter 5-71 Term 32/33 Encoder Direction* or *parameter 17-60 Feedback Direction* to inverse the direction, or reverse the encoder cables. *Parameter 17-60 Feedback Direction* is only available with the VLT® Encoder Input MCB 102 option.

7.4 System Start-up

⚠ WARNING

MOTOR START

Failure to ensure that the motor, system, and any attached equipment are ready for start can result in personal injury or equipment damage. Before start,

- Ensure that equipment is safe to operate under any condition.
- Ensure that the motor, system, and any attached equipment are ready for start.

The procedure in this section requires user-wiring and application programming to be completed. The following procedure is recommended after application set-up is completed.

1. Press [Auto On].
2. Apply an external run command. Examples of external run commands are a switch, key, or programmable logic controller (PLC).
3. Adjust the speed reference throughout the speed range.
4. Ensure that the system is working as intended by checking sound and vibration level of the motor.
5. Remove the external run command.

If warnings or alarms occur, see *chapter 9.5 List of Warnings and Alarms*.

7.5 Parameter Setting

Establishing the correct programming for applications requires setting several parameter functions. Details for parameters are provided in the *programming guide*.

Parameter settings are stored internally in the drive, allowing the following advantages:

- Parameter settings can be uploaded into the LCP memory and stored as a back-up.
- Multiple units can be programmed quickly by connecting the LCP to the unit and downloading the stored parameter settings.
- Settings that are stored in the LCP are not changed when restoring factory default settings.
- Changes made to default settings as well as any programming entered into parameters are stored and available for viewing in the quick menu. See *chapter 3.7 LCP Menus*.

7.5.1 Uploading and Downloading Parameter Settings

The drive operates using parameters stored on the control card, which is located within the drive. The upload and download functions move the parameters between the control card and the LCP.

1. Press [Off].
2. Go to *parameter 0-50 LCP Copy* and press [OK].
3. Select 1 of the following:
 - 3a To upload data from the control card to the LCP, select [1] *All to LCP*.
 - 3b To download data from the LCP to the control card, select [2] *All from LCP*.
4. Press [OK]. A progress bar shows the uploading or downloading process.
5. Press [Hand On] or [Auto On].

7.5.2 Restoring Factory Default Settings

NOTICE

LOSS OF DATA

Loss of programming, motor data, localization, and monitoring records occurs when restoring default settings. To create a back-up, upload data to the LCP before initialization. Refer to *chapter 7.5.1 Uploading and Downloading Parameter Settings*.

Restore the default parameter settings by initializing the unit. Initialization is carried out through *parameter 14-22 Operation Mode* or manually.

Parameter 14-22 Operation Mode does not reset settings such as the following:

- Running hours.
- Serial communication options.
- Personal menu settings.
- Fault log, alarm log, and other monitoring functions.

Recommended initialization

1. Press [Main Menu] twice to access parameters.
2. Go to *parameter 14-22 Operation Mode* and press [OK].
3. Scroll to *Initialization* and press [OK].
4. Remove power to the unit and wait for the display to turn off.
5. Apply power to the unit. Default parameter settings are restored during start-up. Start-up takes slightly longer than normal.
6. After *alarm 80, Drive initialized to default value* appears, press [Reset].

Manual initialization

Manual initialization resets all factory settings except for the following:

- *Parameter 15-00 Operating hours*.
- *Parameter 15-03 Power Up's*.
- *Parameter 15-04 Over Temp's*.
- *Parameter 15-05 Over Volt's*.

To perform manual initialization:

1. Remove power to the unit and wait for the display to turn off.
2. Press and hold [Status], [Main Menu], and [OK] simultaneously while applying power to the unit (approximately 5 s or until an audible click sounds and the fan starts). Start-up takes slightly longer than normal.

8 Wiring Configuration Examples

8.1 Introduction

The examples in this section are intended as a quick reference for common applications.

- Parameter settings are the regional default values unless otherwise indicated (selected in *parameter 0-03 Regional Settings*).
- Parameters associated with the terminals and their settings are shown next to the drawings.
- Required switch settings for analog terminals A53 or A54 are also shown.

8.2 Wiring for Open-loop Speed Control

Parameters	
Function	Setting
Parameter 6-10 Terminal 53 Low Voltage	0.07 V*
Parameter 6-11 Terminal 53 High Voltage	10 V*
Parameter 6-14 Terminal 53 Low Ref./Feedb. Value	0 Hz
Parameter 6-15 Terminal 53 High Ref./Feedb. Value	50 Hz
* = Default value	
Notes/comments: Assumptions are 0 V DC input = 0 Hz speed and 10 V DC input = 50 Hz speed.	

Table 8.1 Analog Speed Reference (Voltage)

Parameters	
Function	Setting
Parameter 6-12 Terminal 53 Low Current	4 mA*
Parameter 6-13 Terminal 53 High Current	20 mA*
Parameter 6-14 Terminal 53 Low Ref./Feedb. Value	0 Hz
Parameter 6-15 Terminal 53 High Ref./Feedb. Value	50 Hz
* = Default value	
Notes/comments: Assumptions are 4 mA input = 0 Hz speed and 20 mA input = 50 Hz speed.	

Table 8.2 Analog Speed Reference (Current)

Parameters	
Function	Setting
Parameter 6-12 Terminal 53 Low Current	4 mA*
Parameter 6-13 Terminal 53 High Current	20 mA*
Parameter 6-14 Terminal 53 Low Ref./Feedb. Value	0 Hz
Parameter 6-15 Terminal 53 High Ref./Feedb. Value	50 Hz
* = Default value	
Notes/comments: Assumptions are 0 V DC input = 0 RPM speed and 10 V DC input = 1500 RPM speed.	

Table 8.3 Speed Reference (Using a Manual Potentiometer)

Parameters	
Function	Setting
Parameter 5-10 Terminal 18 Digital Input	[8] Start*
Parameter 5-12 Terminal 27 Digital Input	[19] Freeze Reference
Parameter 5-13 Terminal 29 Digital Input	[21] Speed Up
Parameter 5-14 Terminal 32 Digital Input	[22] Speed Down
* = Default value	
Notes/comments:	

Table 8.4 Speed Up/Speed Down

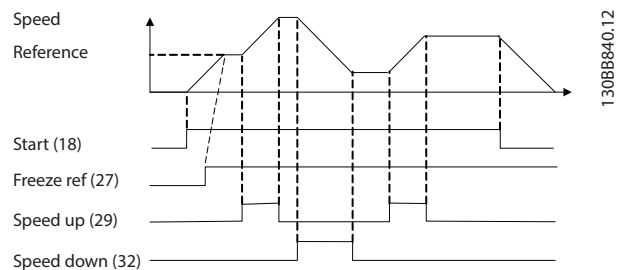
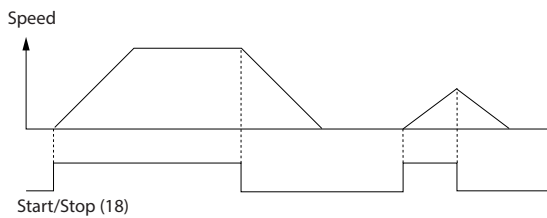

Illustration 8.1 Speed Up/Speed Down

8.3 Wiring for Start/Stop

		Parameters	
FC		Function	Setting
+24 V	12	Parameter 5-10	[8] Start*
+24 V	13	Terminal 18	
D IN	18	Digital Input	
D IN	19	Parameter 5-12	[0] No operation
COM	20	Terminal 27	
D IN	27	Digital Input	
D IN	29	* = Default value	
D IN	32	Notes/comments:	
D IN	33	If parameter 5-12 Terminal 27 Digital Input is set to [0] No operation, a jumper wire to terminal 27 is not needed.	

Table 8.5 Start/Stop Command



130BB805.12

Illustration 8.2 Start/Stop Command

		Parameters	
FC		Function	Setting
+24 V	12	Parameter 5-1	[9] Latched Start
+24 V	13	0 Terminal 18	Start
D IN	18	Digital Input	
D IN	19	Parameter 5-1	[6] Stop Inverse
COM	20	2 Terminal 27	
D IN	27	Digital Input	
D IN	29	* = Default value	
D IN	32	Notes/comments:	
D IN	33		
+10 V	50		
A IN	53		
A IN	54		
COM	55		
A OUT	42		
COM	39		

Table 8.6 Pulse Start/Stop

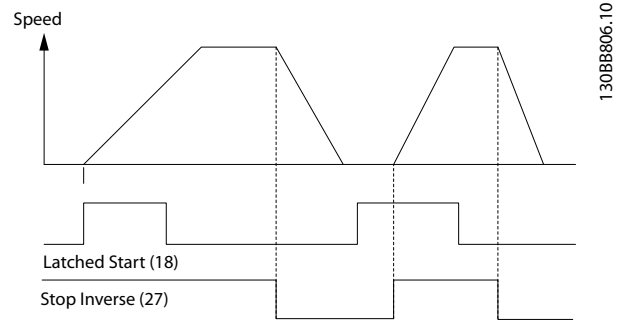

130BB806.10

Illustration 8.3 Latched Start/Stop Inverse

		Parameters	
FC		Function	Setting
+24 V	12	Parameter 5-10	[8] Start
+24 V	13	Terminal 18	
D IN	18	Digital Input	
D IN	19	Parameter 5-11	[10] Reversing*
COM	20	Terminal 19	
D IN	27	Digital Input	
D IN	29	Parameter 5-12	[0] No operation
D IN	32	Terminal 27	
D IN	33	Digital Input	
+10 V	50	Parameter 5-14	[16] Preset ref bit 0
A IN	53	Terminal 32	
A IN	54	Terminal 33	
COM	55	Digital Input	
A OUT	42	Parameter 3-10	Preset Reference
COM	39	Preset ref. 0	25%
		Preset ref. 1	50%
		Preset ref. 2	75%
		Preset ref. 3	100%
		* = Default value	
		Notes/comments:	

Table 8.7 Start/Stop with Reversing and 4 Preset Speeds

8.4 Wiring for External Alarm Reset

		Parameters	
FC		Function	Setting
+24 V	12	Parameter 5-11 Terminal 19 Digital Input	[1] Reset
+24 V	13		
D IN	18	* = Default value	
D IN	19		
COM	20	Notes/comments:	
D IN	27		
D IN	29		
D IN	32		
D IN	33		
+10 V	50		
A IN	53		
A IN	54		
COM	55		
A OUT	42		
COM	39		

Table 8.8 External Alarm Reset

8.5 Wiring for a Motor Thermistor

WARNING

THERMISTOR INSULATION

Risk of personal injury or equipment damage.

- To meet PELV insulation requirements, use only thermistors with reinforced or double insulation.

		Parameters	
VLT		Function	Setting
+24 V	12	Parameter 1-90 Motor Thermal Protection	[2] Thermistor trip
+24 V	13		
D IN	18	* = Default value	
D IN	19		
COM	20	Notes/comments: If only a warning is desired, set parameter 1-90 Motor Thermal Protection to [1] Thermistor warning.	
D IN	27		
D IN	29		
D IN	32		
D IN	33		
+10 V	50		
A IN	53		
A IN	54		
COM	55		
A OUT	42		
COM	39		

Table 8.9 Motor Thermistor

9 Maintenance, Diagnostics, and Troubleshooting

This chapter includes:

- Maintenance and service guidelines.
- Status messages.
- Warnings and alarms.
- Basic troubleshooting.

9.1 Maintenance and Service

Under normal operating conditions and load profiles, the drive is maintenance-free throughout its designed lifetime. To prevent breakdown, danger, and damage, examine the drive at regular intervals depending on the operating conditions. Replace worn or damaged parts with original spare parts or standard parts. For service and support, refer to www.danfoss.com/en/contact-us/contacts-list/?filter=type%3Adanfoss-sales-service-center%2Csegments%3ADDS.

WARNING

UNINTENDED START

When the drive is connected to AC mains, DC supply, or load sharing, the motor can start at any time. Unintended start during programming, service, or repair work can result in death, serious injury, or property damage. The motor can start with an external switch, a fieldbus command, an input reference signal from the LCP or LOP, via remote operation using MCT 10 Set-up Software, or after a cleared fault condition.

To prevent unintended motor start:

- Press [Off/Reset] on the LCP before programming parameters.
- Disconnect the drive from the mains.
- Completely wire and assemble the drive, motor, and any driven equipment before connecting the drive to AC mains, DC supply, or load sharing.

9.2 Heat Sink Access Panel

9.2.1 Removing the Heat Sink Access Panel

The drive can be ordered with an optional access panel in the back of the unit. This panel provides access to the heat sink and allows the heat sink to be cleaned of any dust buildup.

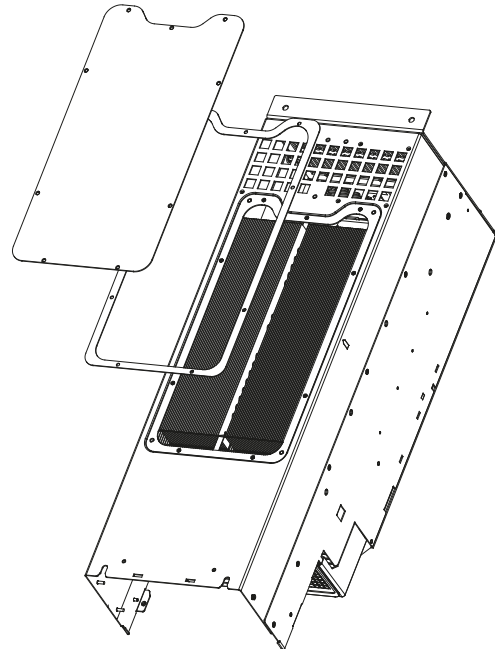

Illustration 9.1 Heat Sink Access Panel

NOTICE

DAMAGE TO HEAT SINK

Using fasteners that are longer than those originally supplied with the heat sink panel can damage the heat sink cooling fins.

1. Remove power from the drive and wait 20 minutes for the capacitors to discharge completely. Refer to *chapter 2 Safety*.
2. Position the drive so that the back of the drive is accessible.
3. Remove the screws (3 mm [0.12 in] internal hex) connecting the access panel to the back of the enclosure. There are 5 or 9 screws depending on the size of the drive.
4. Inspect the heat sink for damage or dust buildup.
5. Remove dust and debris with a vacuum.
6. Replace the panel and secure it to the back of the enclosure with the screws previously removed. Tighten the fasteners according to *chapter 10.8 Fastener Tightening Torques*.

9.3 Status Messages

When the drive is in status mode, status messages automatically appear in the lowest line of the LCP display. Refer to *Illustration 9.2*. Status messages are defined in *Table 9.1 – Table 9.3*.

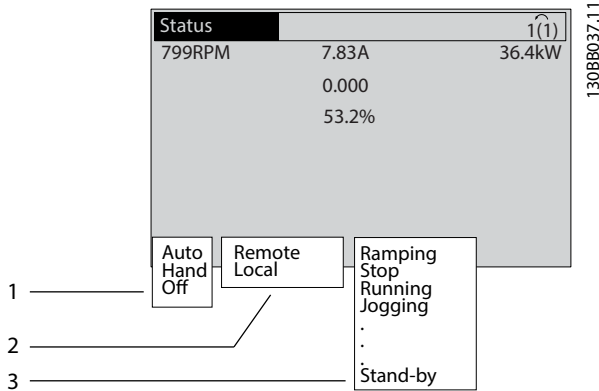

1	Where the stop/start command originates. Refer to <i>Table 9.1</i> .
2	Where the speed control originates. Refer to <i>Table 9.2</i> .
3	Provides the drive status. Refer to <i>Table 9.3</i> .

Illustration 9.2 Status Display

NOTICE

In auto/remote mode, the drive requires external commands to execute functions.

Table 9.1 to Table 9.3 define the meaning of the shown status messages.

Off	The drive does not react to any control signal until [Auto On] or [Hand On] is pressed.
Auto	The start/stop commands are sent via the control terminals and/or the serial communication.
Hand	The navigation keys on the LCP can be used to control the drive. Stop commands, reset, reversing, DC brake, and other signals applied to the control terminals override local control.

Table 9.1 Operating Mode

Remote	The speed reference is given from <ul style="list-style-type: none"> External signals. Serial communication. Internal preset references.
Local	The drive uses reference values from the LCP.

Table 9.2 Reference Site

AC brake	AC brake was selected in <i>parameter 2-10 Brake Function</i> . The AC brake overmagnetizes the motor to achieve a controlled slow down.
AMA finish OK	Automatic motor adaptation (AMA) was carried out successfully.
AMA ready	AMA is ready to start. To start, press [Hand On].
AMA running	AMA process is in progress.
Coast	<ul style="list-style-type: none"> [2] <i>Coast inverse</i> was selected as a function for a digital input (<i>parameter group 5-1* Digital Inputs</i>). The corresponding terminal is not connected. Coast activated by serial communication.
Ctrl. ramp-down	<p>[1] <i>Ctrl. ramp-down</i> was selected in <i>parameter 14-10 Mains Failure</i>.</p> <ul style="list-style-type: none"> The mains voltage is below the value set in <i>parameter 14-11 Mains Fault Voltage Level</i> at mains fault. The drive ramps down the motor using a controlled ramp down.
Current high	The drive output current is above the limit set in <i>parameter 4-51 Warning Current High</i> .
Current low	The drive output current is below the limit set in <i>parameter 4-52 Warning Speed Low</i> .
DC hold	DC hold is selected in <i>parameter 1-80 Function at Stop</i> and a stop command is active. The motor is held by a DC current set in <i>parameter 2-00 DC Hold Current</i> .
DC stop	<p>The motor is held with a DC current (<i>parameter 2-01 DC Brake Current</i>) for a specified time (<i>parameter 2-02 DC Braking Time</i>).</p> <ul style="list-style-type: none"> DC brake is activated in <i>parameter 2-03 DC Brake Cut In Speed [RPM]</i> and a stop command is active. DC brake (inverse) is selected as a function for a digital input (<i>parameter group 5-1* Digital Inputs</i>). The corresponding terminal is not active. The DC brake is activated via serial communication.
Feedback high	The sum of all active feedbacks is above the feedback limit set in <i>parameter 4-57 Warning Feedback High</i> .
Feedback low	The sum of all active feedbacks is below the feedback limit set in <i>parameter 4-56 Warning Feedback Low</i> .

Freeze output	<p>The remote reference is active, which holds the present speed.</p> <ul style="list-style-type: none"> • [20] Freeze Output was selected as a function for a digital input (<i>parameter group 5-1* Digital Inputs</i>). The corresponding terminal is active. Speed control is only possible via the terminal functions speed up and speed down. • Hold ramp is activated via serial communication.
Freeze output request	A freeze output command has been given, but the motor remains stopped until a run permissive signal is received.
Freeze ref.	[19] Freeze Reference was selected as a function for a digital input (<i>parameter group 5-1* Digital Inputs</i>). The corresponding terminal is active. The drive saves the actual reference. Changing the reference is now only possible via terminal functions speed up and speed down.
Jog request	A jog command has been given, but the motor is stopped until a run permissive signal is received via a digital input.
Jogging	<p>The motor is running as programmed in <i>parameter 3-19 Jog Speed [RPM]</i>.</p> <ul style="list-style-type: none"> • [14] Jog was selected as function for a digital input (<i>parameter group 5-1* Digital Inputs</i>). The corresponding terminal (for example, terminal 29) is active. • The jog function is activated via the serial communication. • The jog function was selected as a reaction for a monitoring function (for example, No signal). The monitoring function is active.
OVC control	Overvoltage control was activated in <i>parameter 2-17 Over-voltage Control, [2] Enabled</i> . The connected motor is supplying the drive with generative energy. The overvoltage control adjusts the V/Hz ratio to run the motor in controlled mode and to prevent the drive from tripping.
Power unit off	(For drives with a 24 V DC external supply installed only.) Mains supply to the drive is removed, but the control card is supplied by the 24 V DC external supply.

Protection md	<p>Protection mode is active. The unit has detected a critical status (an overcurrent or overvoltage).</p> <ul style="list-style-type: none"> • To avoid tripping, the switching frequency is reduced to 1500 kHz if <i>parameter 14-55 Output Filter</i> is set to [2] <i>Sine-Wave Filter Fixed</i>. Otherwise, the switching frequency is reduced to 1000 Hz. • If possible, protection mode ends after approximately 10 s. • Protection mode can be restricted in <i>parameter 14-26 Trip Delay at Inverter Fault</i>.
QStop	<p>The motor is decelerating using <i>parameter 3-81 Quick Stop Ramp Time</i>.</p> <ul style="list-style-type: none"> • [4] Quick stop inverse was selected as a function for a digital input (<i>parameter group 5-1* Digital Inputs</i>). The corresponding terminal is not active. • The quick stop function was activated via serial communication.
Ramping	The motor is accelerating/decelerating using the active ramp up/down. The reference, a limit value, or a standstill is not yet reached.
Ref. high	The sum of all active references is above the reference limit set in <i>parameter 4-55 Warning Reference High</i> .
Ref. low	The sum of all active references is below the reference limit set in <i>parameter 4-54 Warning Reference Low</i> .
Run on ref.	The drive is running in the reference range. The feedback value matches the setpoint value.
Run request	A start command has been given, but the motor is stopped until a run permissive signal is received via digital input.
Running	The drive is driving the motor.
Sleep mode	The energy saving function is enabled. This function being enabled means that now the motor has stopped, but that it restarts automatically when required.
Speed high	The motor speed is above the value set in <i>parameter 4-53 Warning Speed High</i> .
Speed low	The motor speed is below the value set in <i>parameter 4-52 Warning Speed Low</i> .
Standby	In auto-on mode, the drive starts the motor with a start signal from a digital input or serial communication.
Start delay	In <i>parameter 1-71 Start Delay</i> , a delay starting time was set. A start command is activated and the motor starts after the start delay time expires.

Start fwd/rev	[12] Enable Start Forward and [13] Enable Start Reverse were selected as functions for 2 different digital inputs (<i>parameter group 5-1* Digital Inputs</i>). The motor starts in forward or reverse depending on which corresponding terminal is activated.
Stop	The drive has received a stop command from 1 of the following: <ul style="list-style-type: none"> • LCP. • Digital input. • Serial communication.
Trip	An alarm occurred and the motor is stopped. Once the cause of the alarm is cleared, reset the drive using 1 of the following: <ul style="list-style-type: none"> • Pressing [Reset]. • Remotely by control terminals. • Via serial communication. Pressing [Reset] or remotely by control terminals or via serial communication.
Trip lock	An alarm occurred and the motor is stopped. Once the cause of the alarm is cleared, cycle power to the drive. Reset the drive manually by 1 of the following: <ul style="list-style-type: none"> • Pressing [Reset]. • Remotely by control terminals. • Via serial communication.

Table 9.3 Operation Status

9.4 Warning and Alarm Types

The drive software issues warnings and alarms to help diagnose issues. The warning or alarm number appears in the LCP.

Warning

A warning indicates that the drive has encountered an abnormal operating condition that leads to an alarm. A warning stops when the abnormal condition is removed or resolved.

Alarm

An alarm indicates a fault that requires immediate attention. The fault always triggers a trip or trip lock. Reset the drive after an alarm.

Reset the drive in any of 4 ways:

- Press [Reset]/[Off/Reset].
- Digital reset input command.
- Serial communication reset input command.
- Auto reset.

Trip

When tripping, the drive suspends operation to prevent damage to the drive and other equipment. When a trip occurs, the motor coasts to a stop. The drive logic continues to operate and monitor the drive status. After the fault condition is remedied, the drive is ready for a reset.

Trip lock

When trip locking, the drive suspends operation to prevent damage to the drive and other equipment. When a trip lock occurs, the motor coasts to a stop. The drive logic continues to operate and monitor the drive status. The drive starts a trip lock only when serious faults occur that can damage the drive or other equipment. After the faults are fixed, cycle the input power before resetting the drive.

Warning and alarm displays

- A warning is shown in the LCP along with the warning number.
- An alarm flashes along with the alarm number.

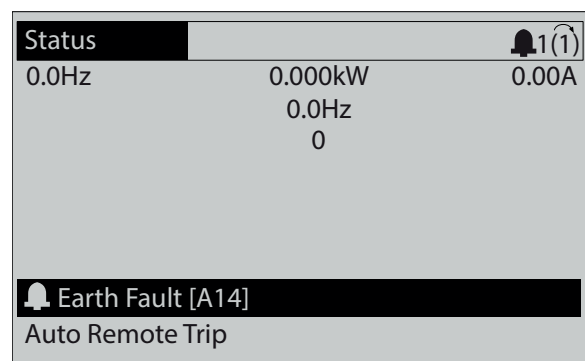
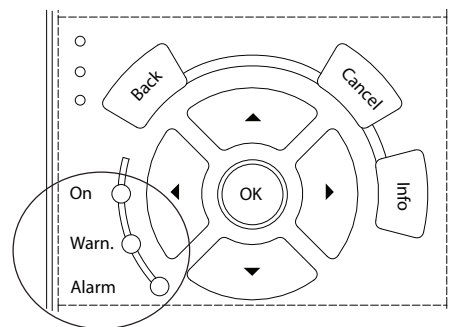

Illustration 9.3 Alarm Example

In addition to the text and alarm code in the LCP, there are 3 status indicator lights.



	Warning indicator light	Alarm indicator light
Warning	On	Off
Alarm	Off	On (flashing)
Trip lock	On	On (flashing)

Illustration 9.4 Status Indicator Lights

9.5 List of Warnings and Alarms

The following warning and alarm information defines each warning or alarm condition, provides the probable cause for the condition, and details a remedy or troubleshooting procedure.

WARNING 1, 10 Volts low

The control card voltage is less than 10 V from terminal 50. Remove some of the load from terminal 50, as the 10 V supply is overloaded. Maximum 15 mA or minimum 590 Ω.

A short circuit in a connected potentiometer or incorrect wiring of the potentiometer can cause this condition.

Troubleshooting

- Remove the wiring from terminal 50. If the warning clears, the problem is with the wiring. If the warning does not clear, replace the control card.

WARNING/ALARM 2, Live zero error

This warning or alarm only appears if programmed in *parameter 6-01 Live Zero Timeout Function*. The signal on 1 of the analog inputs is less than 50% of the minimum value programmed for that input. Broken wiring or a faulty device sending the signal can cause this condition.

Troubleshooting

- Check connections on all analog mains terminals.
 - Control card terminals 53 and 54 for signals, terminal 55 common.
 - VLT® General Purpose I/O MCB 101 terminals 11 and 12 for signals, terminal 10 common.
- Check that the drive programming and switch settings match the analog signal type.
- Perform an input terminal signal test.

WARNING/ALARM 3, No motor

No motor has been connected to the output of the drive.

WARNING/ALARM 4, Mains phase loss

A phase is missing on the supply side, or the mains voltage imbalance is too high. This message also appears for a fault in the input rectifier. Options are programmed in *parameter 14-12 Function at Mains Imbalance*.

Troubleshooting

- Check the supply voltage and supply currents to the drive.

WARNING 5, DC link voltage high

The DC-link voltage (DC) is higher than the high-voltage warning limit. The limit depends on the drive voltage rating. The unit is still active.

WARNING 6, DC link voltage low

The DC-link voltage (DC) is lower than the low-voltage warning limit. The limit depends on the drive voltage rating. The unit is still active.

WARNING/ALARM 7, DC overvoltage

If the DC-link voltage exceeds the limit, the drive trips after a certain time.

Troubleshooting

- Extend the ramp time.
- Change the ramp type.
- Activate the functions in *parameter 2-10 Brake Function*.
- Increase *parameter 14-26 Trip Delay at Inverter Fault*.
- If the alarm/warning occurs during a power sag, use kinetic back-up (*parameter 14-10 Mains Failure*).

WARNING/ALARM 8, DC under voltage

If the DC-link voltage drops below the undervoltage limit, the drive checks for 24 V DC back-up supply. If no 24 V DC back-up supply is connected, the drive trips after a fixed time delay. The time delay varies with unit size.

Troubleshooting

- Check that the supply voltage matches the drive voltage.
- Perform an input voltage test.
- Perform a soft-charge circuit test.

WARNING/ALARM 9, Inverter overload

The drive has run with more than 100% overload for too long and is about to cut out. The counter for electronic thermal inverter protection issues a warning at 98% and trips at 100% with an alarm. The drive cannot be reset until the counter is below 90%.

Troubleshooting

- Compare the output current shown on the LCP with the drive rated current.
- Compare the output current shown on the LCP with the measured motor current.
- Show the thermal drive load on the LCP and monitor the value. When running above the drive continuous current rating, the counter increases. When running below the drive continuous current rating, the counter decreases.

WARNING/ALARM 10, Motor overload temperature

According to the electronic thermal protection (ETR), the motor is too hot.

Select 1 of these options:

- The drive issues a warning or an alarm when the counter is >90% if *parameter 1-90 Motor Thermal Protection* is set to warning options.
- The drive trips when the counter reaches 100% if *parameter 1-90 Motor Thermal Protection* is set to trip options.

The fault occurs when the motor runs with more than 100% overload for too long.

Troubleshooting

- Check for motor overheating.
- Check if the motor is mechanically overloaded.
- Check that the motor current set in *parameter 1-24 Motor Current* is correct.
- Ensure that the motor data in *parameters 1-20 to 1-25* is set correctly.
- If an external fan is in use, check that it is selected in *parameter 1-91 Motor External Fan*.
- Running AMA in *parameter 1-29 Automatic Motor Adaptation (AMA)* tunes the drive to the motor more accurately and reduces thermal loading.

WARNING/ALARM 11, Motor thermistor overtemp

Check whether the thermistor is disconnected. Select whether the drive issues a warning or an alarm in *parameter 1-90 Motor Thermal Protection*.

Troubleshooting

- Check for motor overheating.
- Check if the motor is mechanically overloaded.
- When using terminal 53 or 54, check that the thermistor is connected correctly between either terminal 53 or 54 (analog voltage input) and terminal 50 (+10 V supply). Also check that the terminal switch for 53 or 54 is set for voltage. Check that *parameter 1-93 Thermistor Resource* selects terminal 53 or 54.
- When using terminal 18, 19, 31, 32, or 33 (digital inputs), check that the thermistor is connected correctly between the digital input terminal used (digital input PNP only) and terminal 50. Select the terminal to use in *parameter 1-93 Thermistor Resource*.

WARNING/ALARM 12, Torque limit

The torque has exceeded the value in *parameter 4-16 Torque Limit Motor Mode* or the value in *parameter 4-17 Torque Limit Generator Mode*. *Parameter 14-25 Trip Delay at Torque Limit* can change this warning from a warning-only condition to a warning followed by an alarm.

Troubleshooting

- If the motor torque limit is exceeded during ramp-up, extend the ramp-up time.
- If the generator torque limit is exceeded during ramp-down, extend the ramp-down time.
- If torque limit occurs while running, increase the torque limit. Make sure that the system can operate safely at a higher torque.
- Check the application for excessive current draw on the motor.

WARNING/ALARM 13, Over current

The inverter peak current limit (approximately 200% of the rated current) is exceeded. The warning lasts approximately 1.5 s, then the drive trips and issues an alarm. Shock loading or quick acceleration with high-inertia loads can cause this fault. If the acceleration during ramp-up is quick, the fault can also appear after kinetic back-up.

Troubleshooting

- Remove the power and check if the motor shaft can be turned.
- Check that the motor size matches the drive.
- Check that the motor data is correct in *parameters 1-20 to 1-25*.

ALARM 14, Earth (ground) fault

There is current from the output phase to ground, either in the cable between the drive and the motor, or in the motor itself. The current transducers detect the ground fault by measuring current going out from the drive and current going into the drive from the motor. Ground fault is issued if the deviation of the 2 currents is too large. The current going out of the drive must be the same as the current going into the drive.

Troubleshooting

- Remove power to the drive and repair the ground fault.
- Check for ground faults in the motor by measuring the resistance to ground of the motor cables and the motor with a megohmmeter.
- Reset any potential individual offset in the 3 current transducers in the drive. Perform the manual initialization or perform a complete AMA. This method is most relevant after changing the power card.

ALARM 15, Hardware mismatch

A fitted option is not operational with the present control card hardware or software.

Record the value of the following parameters and contact Danfoss.

- *Parameter 15-40 FC Type.*
- *Parameter 15-41 Power Section.*
- *Parameter 15-42 Voltage.*
- *Parameter 15-43 Software Version.*
- *Parameter 15-45 Actual Typecode String.*
- *Parameter 15-49 SW ID Control Card.*
- *Parameter 15-50 SW ID Power Card.*
- *Parameter 15-60 Option Mounted.*
- *Parameter 15-61 Option SW Version* (for each option slot).

ALARM 16, Short circuit

There is short-circuiting in the motor or motor wiring.

Troubleshooting

- Remove the power to the drive and repair the short circuit.

⚠ WARNING**HIGH VOLTAGE**

Drives contain high voltage when connected to AC mains input, DC supply, or load sharing. Failure to use qualified personnel to install, start up, and maintain the drive can result in death or serious injury.

- Disconnect power before proceeding.

WARNING/ALARM 17, Control word timeout

There is no communication to the drive.

The warning is only active when *parameter 8-04 Control Word Timeout Function* is NOT set to [0] Off.

If *parameter 8-04 Control Word Timeout Function* is set to [5] Stop and trip, a warning appears, and the drive ramps down to a stop and shows an alarm.

Troubleshooting

- Check the connections on the serial communication cable.
- Increase *parameter 8-03 Control Word Timeout Time*.
- Check the operation of the communication equipment.
- Verify that proper EMC installation was performed.

ALARM 18, Start failed

The speed cannot exceed the value set in *parameter 1-78 Compressor Start Max Speed [Hz]* during start within the allowed time, which is set in *parameter 1-79 Compressor Start Max Time to Trip*. The alarm may be caused by a blocked motor.

WARNING/ALARM 21, Parameter error

The parameter is out of range. The parameter number is shown in the display.

Troubleshooting

- Set the affected parameter to a valid value.

WARNING 23, Internal fan fault

The fan warning function is a protective function that checks if the fan is running/mounted. The fan warning can be disabled in *parameter 14-53 Fan Monitor ([0] Disabled)*.

For drives with DC fans, a feedback sensor is mounted in the fan. If the fan is commanded to run and there is no feedback from the sensor, this alarm appears. For drives with AC fans, the voltage to the fan is monitored.

Troubleshooting

- Check for proper fan operation.
- Cycle power to the drive and check that the fan operates briefly at start-up.
- Check the sensors on the control card.

WARNING 24, External fan fault

The fan warning function is a protective function that checks if the fan is running/mounted. The fan warning can be disabled in *parameter 14-53 Fan Monitor ([0] Disabled)*.

For drives with DC fans, a feedback sensor is mounted in the fan. If the fan is commanded to run and there is no feedback from the sensor, this alarm appears. For drives with AC fans, the voltage to the fan is monitored.

Troubleshooting

- Check for proper fan operation.
- Cycle power to the drive and check that the fan operates briefly at start-up.
- Check the sensors on the heat sink.

ALARM 29, Power module temp

The power module is above the temperature limit. If the enclosure is IP00 or IP20/NEMA 1, the cutout temperature of the heat sink is 90 °C (194 °F).

ALARM 30, Motor phase U missing

Motor phase U between the drive and the motor is missing.

⚠ WARNING**HIGH VOLTAGE**

Drives contain high voltage when connected to AC mains input, DC supply, or load sharing. Failure to perform installation, start-up, and maintenance by qualified personnel can result in death or serious injury.

- Only qualified personnel must perform installation, start-up, and maintenance.
- Before performing any service or repair work, use an appropriate voltage measuring device to make sure that there is no remaining voltage on the drive.

Troubleshooting

- Remove the power from the drive and check motor phase U.

ALARM 31, Motor phase V missing

Motor phase V between the drive and the motor is missing.

⚠️ WARNING

HIGH VOLTAGE

Drives contain high voltage when connected to AC mains input, DC supply, or load sharing. Failure to perform installation, start-up, and maintenance by qualified personnel can result in death or serious injury.

- Only qualified personnel must perform installation, start-up, and maintenance.
- Before performing any service or repair work, use an appropriate voltage measuring device to make sure that there is no remaining voltage on the drive.

Troubleshooting

- Remove the power from the drive and check motor phase V.

ALARM 32, Motor phase W missing

Motor phase W between the drive and the motor is missing.

⚠️ WARNING

HIGH VOLTAGE

Drives contain high voltage when connected to AC mains input, DC supply, or load sharing. Failure to perform installation, start-up, and maintenance by qualified personnel can result in death or serious injury.

- Only qualified personnel must perform installation, start-up, and maintenance.
- Before performing any service or repair work, use an appropriate voltage measuring device to make sure that there is no remaining voltage on the drive.

Troubleshooting

- Remove the power from the drive and check motor phase W.

ALARM 33, Inrush fault

Too many power-ups have occurred within a short time period.

Troubleshooting

- Let the unit cool to operating temperature.
- Check potential DC-link fault to ground.

WARNING/ALARM 34, Fieldbus communication fault

The fieldbus on the communication option card is not working.

WARNING/ALARM 35, Option fault

An option alarm is received. The alarm is option-specific. The most likely cause is a power-up or a communication fault.

WARNING/ALARM 36, Mains failure

This warning/alarm is only active if the supply voltage to the drive is lost and *parameter 14-10 Mains Failure* is not set to [0] No function.

Troubleshooting

- Check the fuses to the drive and mains supply to the unit.

ALARM 37, Phase imbalance

There is a current imbalance between the power units.

ALARM 38, Internal fault

When an internal fault occurs, a code number defined in *Table 9.4* is shown.

Troubleshooting

- Cycle power.
- Check that the option is properly installed.
- Check for loose or missing wiring.

It may be necessary to contact the Danfoss supplier or service department. Note the code number for further troubleshooting directions.

Number	Text
0	The serial port cannot be initialized. Contact the Danfoss supplier or Danfoss service department.
256–258	The power EEPROM data is defective or too old. Replace the power card.
512–519	Internal fault. Contact the Danfoss supplier or Danfoss service department.
783	Parameter value outside of minimum/maximum limits.
1024–1284	Internal fault. Contact the Danfoss supplier or Danfoss service department.
1299	The option software in slot A is too old.
1300	The option software in slot B is too old.
1315	The option software in slot A is not supported/allowed.
1316	The option software in slot B is not supported/allowed.
1379–2819	Internal fault. Contact the Danfoss supplier or Danfoss service department.
1792	Hardware reset of digital signal processor.
1793	Motor-derived parameters not transferred correctly to the digital signal processor.
1794	Power data not transferred correctly at power-up to the digital signal processor.
1795	The digital signal processor has received too many unknown SPI telegrams. This situation can occur due to poor EMC protection or improper grounding.
1796	RAM copy error.
1798	Software version 48.3X or newer is used with MK1 control card. Replace with MKII issue 8 control card.
2561	Replace the control card.

Number	Text
2820	LCP stack overflow.
2821	Serial port overflow.
2822	USB port overflow.
3072–5122	Parameter value is outside its limits.
5123	Option in slot A: Hardware incompatible with the control board hardware.
5124	Option in slot B: Hardware incompatible with the control board hardware.
5376–6231	Internal fault. Contact the Danfoss supplier or Danfoss service department.

Table 9.4 Internal Fault Codes

ALARM 39, Heat sink sensor

No feedback from the heat sink temperature sensor.

The signal from the IGBT thermal sensor is not available on the power card. The problem could be on the power card, on the gatedrive card, or the ribbon cable between the power card and gatedrive card.

WARNING 40, Overload of digital output terminal 27

Check the load connected to terminal 27 or remove the short-circuit connection. Check *parameter 5-00 Digital I/O Mode* and *parameter 5-01 Terminal 27 Mode*.

WARNING 41, Overload of digital output terminal 29

Check the load connected to terminal 29 or remove the short-circuit connection. Also check *parameter 5-00 Digital I/O Mode* and *parameter 5-02 Terminal 29 Mode*.

WARNING 42, Overload of digital output on X30/6 or overload of digital output on X30/7

For terminal X30/6, check the load connected to terminal X30/6 or remove the short-circuit connection. Also check *parameter 5-32 Term X30/6 Digi Out (MCB 101)* (VLT® General Purpose I/O MCB 101).

For terminal X30/7, check the load connected to terminal X30/7 or remove the short-circuit connection. Check *parameter 5-33 Term X30/7 Digi Out (MCB 101)* (VLT® General Purpose I/O MCB 101).

ALARM 45, Earth fault 2

Ground fault.

Troubleshooting

- Check for proper grounding and loose connections.
- Check for proper wire size.
- Check the motor cables for short circuits or leakage currents.

ALARM 46, Power card supply

The supply for the gate drive on the power card is out of range.

Troubleshooting

- Check for a defective power card.

WARNING 47, 24 V supply low

The 24 V DC is measured on the control card.

Troubleshooting

- Contact the Danfoss supplier or Danfoss service department.

WARNING 48, 1.2 V supply low

The 1.2 V DC supply used on the control card is outside of the allowable limits. The supply is measured on the control card.

Troubleshooting

- Check for a defective control card.
- If an option card is present, check for overvoltage.

WARNING 49, Speed limit

The warning is shown when the speed is outside of the specified range in *parameter 4-11 Motor Speed Low Limit [RPM]* and *parameter 4-13 Motor Speed High Limit [RPM]*. When the speed is below the specified limit in *parameter 1-86 Trip Speed Low [RPM]* (except when starting or stopping), the drive trips.

ALARM 50, AMA calibration failed

Contact the Danfoss supplier or Danfoss service department.

ALARM 51, AMA check U_{nom} and I_{nom}

The settings for motor voltage, motor current, and motor power are wrong.

Troubleshooting

- Check the settings in *parameters 1-20 to 1-25*.

ALARM 52, AMA low I_{nom}

The motor current is too low.

Troubleshooting

- Check the settings in *parameter 1-24 Motor Current*.

ALARM 53, AMA motor too big

The motor is too large for the AMA to operate.

ALARM 54, AMA motor too small

The motor is too small for the AMA to operate.

ALARM 55, AMA parameter out of range

The AMA cannot run because the parameter values of the motor are outside of the acceptable range.

ALARM 56, AMA interrupted by user

The AMA is manually interrupted.

ALARM 57, AMA internal fault

Try to restart the AMA. Repeated restarts can overheat the motor.

ALARM 58, AMA Internal fault

Contact the Danfoss supplier.

WARNING 59, Current limit

The current is higher than the value in *parameter 4-18 Current Limit*. Ensure that the motor data in *parameters 1-20 to 1-25* is set correctly. Increase the current limit if necessary. Ensure that the system can operate safely at a higher limit.

WARNING 60, External interlock

A digital input signal indicates a fault condition external to the drive. An external interlock has commanded the drive to trip. Clear the external fault condition. To resume normal operation, apply 24 V DC to the terminal programmed for external interlock, and reset the drive.

WARNING/ALARM 61, Feedback error

An error between calculated speed and speed measurement from feedback device.

Troubleshooting

- Check the settings for warning/alarm/disabling in *parameter 4-30 Motor Feedback Loss Function*.
- Set the tolerable error in *parameter 4-31 Motor Feedback Speed Error*.
- Set the tolerable feedback loss time in *parameter 4-32 Motor Feedback Loss Timeout*.

WARNING 62, Output frequency at maximum limit

If the output frequency reaches the value set in *parameter 4-19 Max Output Frequency*, the drive issues a warning. The warning ceases when the output drops below the maximum limit. If the drive is unable to limit the frequency, it trips and issues an alarm. The latter may happen in the flux mode if the drive loses control of the motor.

Troubleshooting

- Check the application for possible causes.
- Increase the output frequency limit. Ensure that the system can operate safely at a higher output frequency.

WARNING 64, Voltage Limit

The load and speed combination demands a motor voltage higher than the actual DC-link voltage.

WARNING/ALARM 65, Control card over temperature

The cutout temperature of the control card is 85 °C (185 °F).

Troubleshooting

- Check that the ambient operating temperature is within the limits.
- Check for clogged filters.
- Check the fan operation.
- Check the control card.

WARNING 66, Heat sink temperature low

The drive is too cold to operate. This warning is based on the temperature sensor in the IGBT module. Increase the ambient temperature of the unit. Also, a trickle amount of current can be supplied to the drive whenever the motor is stopped by setting *parameter 2-00 DC Hold/Preheat Current* to 5% and *parameter 1-80 Function at Stop*.

ALARM 67, Option module configuration has changed

One or more options have either been added or removed since the last power-down. Check that the configuration change is intentional and reset the unit.

ALARM 69, Power card temperature

The temperature sensor on the power card is either too hot or too cold.

Troubleshooting

- Check that the ambient operating temperature is within limits.
- Check for clogged filters.
- Check fan operation.
- Check the power card.

ALARM 70, Illegal FC configuration

The control card and power card are incompatible. To check compatibility, contact the Danfoss supplier with the type code from the unit nameplate and the part numbers of the cards.

WARNING 76, Power unit setup

The required number of power units does not match the detected number of active power units. When replacing an enclosure size F module, this warning occurs if the power-specific data in the module power card does not match the rest of the drive. If the power card connection is lost, the unit also triggers this warning.

Troubleshooting

- Confirm that the spare part and its power card are the correct part number.
- Ensure that the 44-pin cables between the MDCIC and power cards are mounted properly.

WARNING 77, Reduced power mode

This warning indicates that the drive is operating in reduced power mode (that is, less than the allowed number of inverter sections). This warning is generated on power cycle when the drive is set to run with fewer inverters and remains on.

ALARM 78, Tracking error

The difference between setpoint value and actual value exceeds the value in *parameter 4-35 Tracking Error*.

Troubleshooting

- Disable the function or select an alarm/warning in *parameter 4-34 Tracking Error Function*.
- Investigate the mechanics around the load and motor. Check feedback connections from motor encoder to drive.
- Select motor feedback function in *parameter 4-30 Motor Feedback Loss Function*.
- Adjust the tracking error band in *parameter 4-35 Tracking Error* and *parameter 4-37 Tracking Error Ramping*.

ALARM 79, Illegal power section configuration

The scaling card has an incorrect part number or is not installed. The MK102 connector on the power card could not be installed.

ALARM 80, Drive initialised to default value

Parameter settings are initialized to default settings after a manual reset. To clear the alarm, reset the unit.

ALARM 81, CSIV corrupt

CSIV file has syntax errors.

ALARM 82, CSIV parameter error

CSIV failed to initialize a parameter.

ALARM 83, Illegal option combination

The mounted options are incompatible.

ALARM 88, Option detection

A change in the option layout is detected.

Parameter 14-89 Option Detection is set to [0] *Frozen configuration* and the option layout has been changed.

- To apply the change, enable option layout changes in *parameter 14-89 Option Detection*.
- Alternatively, restore the correct option configuration.

ALARM 90, Feedback monitor

Check the connection to encoder/resolver option and, if necessary, replace VLT® Encoder Input MCB 102 or VLT® Resolver Input MCB 103.

ALARM 91, Analog input 54 wrong settings

Set switch S202 in position OFF (voltage input) when a KTY sensor is connected to analog input terminal 54.

ALARM 95, Broken belt

Torque is below the torque level set for no load, indicating a broken belt. *Parameter 22-60 Broken Belt Function* is set for alarm.

Troubleshooting

- Troubleshoot the system and reset the frequency converter after clearing the fault.

ALARM 99, Locked rotor

The rotor is blocked.

WARNING/ALARM 101, Speed monitor

The speed monitor is out of range.

WARNING/ALARM 104, Mixing fan fault

The fan is not operating. The fan monitor checks that the fan is spinning at power-up or whenever the mixing fan is turned on. The mixing-fan fault can be configured as a warning or an alarm trip in *parameter 14-53 Fan Monitor*.

Troubleshooting

- Cycle power to the drive to determine if the warning/alarm returns.

WARNING/ALARM 122, Mot. rotat. unexp.

The drive performs a function that requires the motor to be at standstill, for example DC hold for PM motors.

WARNING/ALARM 148, System temp

One or more of the system temperature measurements is too high.

WARNING/ALARM 154, D.out overload

Digital output overloaded.

ALARM 244, Heat sink temperature

This alarm is equivalent to *ALARM 29, Power module temp*.

The report value in the alarm log indicates which power module generated the alarm:

- 1 = Leftmost inverter module.
- 2 = Middle inverter module.
- 2 = Right inverter module.
- 2 = Second drive from the left inverter module.
- 3 = Right inverter module.
- 3 = Third from the left inverter module.
- 4 = Far right inverter module.
- 5 = Rectifier module.
- 6 = Right rectifier module.

ALARM 245, Heat sink sensor

There is no feedback from the heat sink sensor.

The report value in the alarm log indicates which power module generated the alarm:

- 1 = Leftmost inverter module.
- 2 = Middle inverter module.
- 2 = Right inverter module.
- 2 = Second drive from the left inverter module.
- 3 = Right inverter module.
- 3 = Third from the left inverter module.
- 4 = Far right inverter module.
- 5 = Rectifier module.
- 6 = Right rectifier module.

ALARM 246, Power card supply

The supply on the power card is out of range.

The report value in the alarm log indicates which power module generated the alarm:

- 1 = Leftmost inverter module.
- 2 = Middle inverter module.
- 2 = Right inverter module.
- 2 = Second drive from the left inverter module.
- 3 = Right inverter module.
- 3 = Third from the left inverter module.
- 4 = Far right inverter module.
- 5 = Rectifier module.
- 6 = Right rectifier module.

ALARM 247, Power card temperature

The supply on the power card is out of range.

The report value in the alarm log indicates which power module generated the alarm:

- 1 = Leftmost inverter module.
- 2 = Middle inverter module.

- 2 = Right inverter module.
- 2 = Second drive from the left inverter module.
- 3 = Right inverter module.
- 3 = Third from the left inverter module.
- 4 = Far right inverter module.
- 5 = Rectifier module.
- 6 = Right rectifier module.

ALARM 248, Illegal power section configuration

Power size configuration fault on the power card.

The report value in the alarm log indicates which power module generated the alarm:

- 1 = Leftmost inverter module.
- 2 = Middle inverter module.
- 2 = Right inverter module.
- 2 = Second drive from the left inverter module.
- 3 = Right inverter module.
- 3 = Third from the left inverter module.
- 4 = Far right inverter module.
- 5 = Rectifier module.
- 6 = Right rectifier module.

WARNING 249, Rect. low temperature

The temperature of the rectifier heat sink is too low, which indicates that the temperature sensor may be defect.

WARNING 250, New spare part

The power or switch mode supply has been exchanged. Restore the drive type code in the EEPROM. Select the correct type code in *parameter 14-23 Typecode Setting* according to the label on the drive. Remember to select Save to EEPROM at the end.

WARNING 251, New typecode

The power card or other components are replaced, and the type code has changed.

9.6 Troubleshooting

Symptom	Possible cause	Test	Solution
Display dark/No function	Missing input power.	See <i>Table 6.1</i> .	Check the input power source.
	Missing or open fuses.	See <i>Open power fuses</i> in this table for possible causes.	Follow the recommendations provided.
	No power to the LCP.	Check the LCP cable for proper connection or damage.	Replace the faulty LCP or connection cable.
	Shortcut on control voltage (terminal 12 or 50) or at control terminals.	Check the 24 V control voltage supply for terminal 12/13 to 20–39, or 10 V supply for terminals 50–55.	Wire the terminals properly.
	Incompatible LCP (Check if an incompatible LCP from VLT® 2800 or 5000/6000/8000/ FCD or FCM is used in this frequency converter).	–	Use only LCP 101 (P/N 130B1124) or LCP 102 (P/N 130B1107).
	Wrong contrast setting.	–	Press [Status] + [▲]/[▼] to adjust the contrast.
	Display (LCP) is defective.	Test using a different LCP.	Replace the faulty LCP or connection cable.
Intermittent display	Internal voltage supply fault or SMPS is defective.	–	Contact supplier.
	Overloaded supply (SMPS) due to improper control wiring or a fault within the AC drive.	To rule out a problem in the control wiring, disconnect all control wiring by removing the terminal blocks.	If the display stays lit, the problem is in the control wiring. Check the wiring for shorts or incorrect connections. If the display continues to cut out, follow the procedure for <i>Display dark/No function</i> .
Motor not running	Service switch open or missing motor connection.	Check if the motor is connected and the connection is not interrupted by a service switch or other device.	Connect the motor and check the service switch.
	No mains power with 24 V DC option card.	If the display is functioning, but there is no output, check that mains power is applied to the AC drive.	Apply mains power.
	LCP Stop.	Check if [Off] has been pressed.	Press [Auto On] or [Hand On] (depending on operating mode).
	Missing start signal (Standby).	Check <i>parameter 5-10 Terminal 18 Digital Input</i> for correct setting for terminal 18. Use default setting.	Apply a valid start signal.
	Motor coast signal active (Coasting).	Check <i>parameter 5-12 Terminal 27 Digital Input</i> for correct setting for terminal 27 (use default setting).	Apply 24 V on terminal 27 or program this terminal to [0] <i>No operation</i> .
	Wrong reference signal source.	Check reference signal: <ul style="list-style-type: none"> • Local. • Remote or bus reference? • Preset reference active? • Terminal connection correct? • Scaling of terminals correct? • Reference signal available? 	Program correct settings. Check <i>parameter 3-13 Reference Site</i> . Set preset reference active in <i>parameter group 3-1* References</i> . Check for correct wiring. Check scaling of terminals. Check reference signal.

Symptom	Possible cause	Test	Solution
Motor running in wrong direction	Motor rotation limit.	Check that <i>parameter 4-10 Motor Speed Direction</i> is programmed correctly.	Program correct settings.
	Active reversing signal.	Check if a reversing command is programmed for the terminal in <i>parameter group 5-1* Digital inputs</i> .	Deactivate reversing signal.
	Wrong motor phase connection.	–	See <i>chapter 7.3.1 Warning - Motor Start</i> .
Motor is not reaching maximum speed	Frequency limits set wrong.	Check output limits in <i>parameter 4-13 Motor Speed High Limit [RPM]</i> , <i>parameter 4-14 Motor Speed High Limit [Hz]</i> , and <i>parameter 4-19 Max Output Frequency</i>	Program correct limits.
	Reference input signal not scaled correctly.	Check reference input signal scaling in <i>parameter group 6-0* Analog I/O mode</i> and <i>parameter group 3-1* References</i> .	Program correct settings.
Motor speed unstable	Possible incorrect parameter settings.	Check the settings of all motor parameters, including all motor compensation settings. For closed-loop operation, check PID settings.	Check settings in <i>parameter group 1-6* Load Depen. Setting</i> . For closed-loop operation, check settings in <i>parameter group 20-0* Feedback</i> .
Motor runs rough	Possible overmagnetization.	Check for incorrect motor settings in all motor parameters.	Check motor settings in <i>parameter groups 1-2* Motor data</i> , <i>1-3* Adv Motor Data</i> , and <i>1-5* Load Indep. Setting</i> .
Motor does not brake	Possible incorrect settings in the brake parameters. Ramp-down times may be too short.	Check brake parameters. Check ramp time settings.	Check <i>parameter groups 2-0* DC Brake</i> and <i>3-0* Reference Limits</i> .
Open power fuses	Phase-to-phase short.	Motor or panel has a short phase-to-phase. Check motor and panel phases for shorts.	Eliminate any shorts detected.
	Motor overload.	Motor is overloaded for the application.	Perform start-up test and verify that motor current is within specifications. If motor current is exceeding the nameplate full load current, the motor can run only with reduced load. Review the specifications for the application.
	Loose connections.	Perform pre-start-up check for loose connections.	Tighten loose connections.
Mains current imbalance greater than 3%	Problem with mains power (see <i>alarm 4, Mains phase loss</i> description).	Rotate input power leads into the 1 position: A to B, B to C, C to A.	If imbalanced leg follows the wire, it is a power problem. Check the mains supply.
	Problem with the AC drive.	Rotate input power leads into the AC drive 1 position: A to B, B to C, C to A.	If the imbalanced leg stays on same input terminal, it is a problem with the AC drive. Contact supplier.
Motor current imbalance greater than 3%	Problem with motor or motor wiring.	Rotate output motor cables 1 position: U to V, V to W, W to U.	If the imbalanced leg follows the wire, the problem is in the motor or motor wiring. Check motor and motor wiring.
	Problem with AC drive.	Rotate output motor cables 1 position: U to V, V to W, W to U.	If the imbalanced leg stays on same output terminal, it is a problem with the unit. Contact supplier.
AC drive acceleration problems	Motor data are entered incorrectly.	If warnings or alarms occur, see <i>chapter 9.5 List of Warnings and Alarms</i> . Check that motor data are entered correctly.	Increase the ramp-up time in <i>parameter 3-41 Ramp 1 Ramp Up Time</i> . Increase current limit in <i>parameter 4-18 Current Limit</i> . Increase torque limit in <i>parameter 4-16 Torque Limit Motor Mode</i> .

Symptom	Possible cause	Test	Solution
AC drive deceleration problems	Motor data are entered incorrectly.	If warnings or alarms occur, see <i>chapter 9.5 List of Warnings and Alarms</i> . Check that motor data are entered correctly.	Increase the ramp-down time in <i>parameter 3-42 Ramp 1 Ramp Down Time</i> . Enable overvoltage control in <i>parameter 2-17 Over-voltage Control</i> .

Table 9.5 Troubleshooting

10 Specifications

10.1 Electrical Data, 380-480 V

VLT® AutomationDrive FC 361	N90K		N110		N132		N160	
High/normal overload (High overload=150% current during 60 s, normal overload=110% current during 60 s)	NO	HO	NO	HO	NO	HO	NO	
Typical shaft output at 400 V [kW]	90	90	110	110	132	132	160	
Typical shaft output at 460 V [hp]	125	125	150	150	200	200	250	
Enclosure size	J8							
Output current (3-phase)								
Continuous (at 400 V) [A]	177	177	212	212	260	260	315	
Intermittent (60 s overload) (at 400 V) [A]	195	266	233	318	286	390	347	
Continuous (at 460 V) [A]	160	160	190	190	240	240	302	
Intermittent (60 s overload) (at 460 V) [kVA]	176	240	209	285	264	360	332	
Continuous kVA (at 400 V) [kVA]	123	123	147	147	180	180	218	
Continuous kVA (at 460 V) [kVA]	127	127	151	151	191	191	241	
Maximum input current								
Continuous (at 400 V) [A]	171	171	204	204	251	251	304	
Continuous (at 460 V) [A]	154	154	183	183	231	231	291	
Maximum number and size of cables per phase								
Mains and motor [mm ² (AWG)]	2x95 (2x3/0)							
Maximum external mains fuses [A] ¹⁾	315	315		350		400		
Estimated power loss at 400 V [W] ^{2), 3)}	2031	2031	2559	2289	2954	2923	3770	
Estimated power loss at 460 V [W] ^{2), 3)}	1828	1828	2261	2051	2724	2089	3628	
Efficiency ³⁾	0.98							
Output frequency [Hz]	0–590							
Heat sink overtemperature trip [°C (°F)]	110 (230)							
Weight, enclosure protection rating IP20 kg (lbs)	98 (216)							
Efficiency ³⁾	0.98							
Output frequency [Hz]	0–590							
Heat sink overtemperature trip [°C (°F)]	110 (230)							
Control card overtemperature trip [°C (°F)]	75 (167)							

10

Table 10.1 Electrical Data for Enclosures J8, Mains Supply 3x380–480 V AC

1) For fuse ratings, see chapter 10.7 Fuses and Circuit Breakers.

2) Typical power loss is at normal conditions and expected to be within ±15% (tolerance relates to variety in voltage and cable conditions). These values are based on a typical motor efficiency (IE/IE3 border line). Lower efficiency motors add to the power loss in the drive. Applies for dimensioning of drive cooling. If the switching frequency is higher than the default setting, the power losses can increase. LCP and typical control card power consumptions are included. For power loss data according to EN 50598-2, refer to drives.danfoss.com/knowledge-center/energy-efficiency-directive/#/. Options and customer load can add up to 30 W to the losses, though usually a fully loaded control card and options for slots A and B each add only 4 W.

3) Measured using 5 m (16.4 ft) shielded motor cables at rated load and rated frequency. Efficiency measured at nominal current. For energy efficiency class, see chapter 10.4 Ambient Conditions. For part load losses, see drives.danfoss.com/knowledge-center/energy-efficiency-directive/#/.

VLT® AutomationDrive FC 361	N200		N250		N315	
High/normal overload (High overload=150% current during 60 s, normal overload=110% current during 60 s)	HO	NO	HO	NO	HO	NO
Typical shaft output at 400 V [kW]	160	200	200	250	250	315
Typical shaft output at 460 V [hp]	250	300	300	350	350	450
Enclosure size	J9					
Output current (3-phase)						
Continuous (at 400 V) [A]	315	395	395	480	480	588
Intermittent (60 s overload) (at 400 V)[A]	473	435	593	528	720	647
Continuous (at 460 V) [A]	302	361	361	443	443	535
Intermittent (60 s overload) (at 460 V) [kVA]	453	397	542	487	665	589
Continuous kVA (at 400 V) [kVA]	218	274	274	333	333	407
Continuous kVA (at 460 V) [kVA]	241	288	288	353	353	426
Maximum input current						
Continuous (at 400 V) [A]	304	381	381	463	463	567
Continuous (at 460 V) [A]	291	348	348	427	427	516
Maximum number and size of cables per phase						
Mains and motor [mm ² (AWG)]	2x185 (2x350 mcm)					
Maximum external mains fuses [A] ¹⁾	550		630		800	
Estimated power loss at 400 V [W] ^{2), 3)}	3093	4116	4039	5137	5004	6674
Estimated power loss at 460 V [W] ^{2), 3)}	2872	3569	3575	4566	4458	5714
Efficiency ³⁾	0.98					
Output frequency [Hz]	0-590					
Heat sink overtemperature trip [°C (°F)]	110 (230)					
Weight, enclosure protection rating IP20 kg (lbs)	164 (362)					
Efficiency ³⁾	0.98					
Output frequency [Hz]	0-590					
Heat sink overtemperature trip [°C (°F)]	110 (230)					
Control card overtemperature trip [°C (°F)]	80 (176)					

Table 10.2 Electrical Data for Enclosures J9, Mains Supply 3x380-480 V AC

1) For fuse ratings, see chapter 10.7 Fuses and Circuit Breakers.

2) Typical power loss is at normal conditions and expected to be within $\pm 15\%$ (tolerance relates to variety in voltage and cable conditions). These values are based on a typical motor efficiency (IE/IE3 border line). Lower efficiency motors add to the power loss in the drive. Applies for dimensioning of drive cooling. If the switching frequency is higher than the default setting, the power losses can increase. LCP and typical control card power consumptions are included. For power loss data according to EN 50598-2, refer to drives.danfoss.com/knowledge-center/energy-efficiency-directive/#/. Options and customer load can add up to 30 W to the losses, though usually a fully loaded control card and options for slots A and B each add only 4 W.

3) Measured using 5 m (16.4 ft) shielded motor cables at rated load and rated frequency. Efficiency measured at nominal current. For energy efficiency class, see chapter 10.4 Ambient Conditions. For part load losses, see drives.danfoss.com/knowledge-center/energy-efficiency-directive/#/.

10.2 Mains Supply

Mains supply (L1, L2, L3)

Supply voltage	380–480 V ±10%
----------------	----------------

Mains voltage low/mains voltage drop-out:

During low mains voltage or a mains drop-out, the drive continues until the DC-link voltage drops below the minimum stop level, which corresponds typically to 15% below the lowest rated supply voltage of the drive. Power-up and full torque cannot be expected at mains voltage lower than 10% below the lowest rated supply voltage of the drive.

Supply frequency	50/60 Hz ±5%
------------------	--------------

Maximum imbalance temporary between mains phases	3.0% of rated supply voltage ¹⁾
--	--

True power factor (λ)	≥0.9 nominal at rated load
---------------------------------	----------------------------

Displacement power factor (cos Φ) near unity	(>0.98)
--	---------

Switching on input supply L1, L2, L3 (power ups)	Maximum 1 time/2 minute
--	-------------------------

Environment according to EN60664-1	Overvoltage category III/pollution degree 2
------------------------------------	---

The drive is suitable for use on a circuit capable of delivering up to 100 kA short circuit current rating (SCCR) at 480/600 V.

1) Calculations based on IEC61800-3.

10.3 Motor Output and Motor Data

Motor output (U, V, W)

Output voltage	0–100% of supply voltage
----------------	--------------------------

Output frequency	0–590 Hz ¹⁾
------------------	------------------------

Output frequency in flux mode	0–300 Hz
-------------------------------	----------

Switching on output	Unlimited
---------------------	-----------

Ramp times	0.01–3600 s
------------	-------------

1) Dependent on voltage and power.

Torque characteristics

Starting torque (constant torque)	Maximum 150% for 60 s ^{1), 2)}
-----------------------------------	---

Overload torque (constant torque)	Maximum 150% for 60 s ^{1), 2)}
-----------------------------------	---

1) Percentage relates to the nominal current of the drive.

2) Once every 10 minutes.

10.4 Ambient Conditions

Environment

J8/J9 enclosure	IP20/Chassis
-----------------	--------------

Vibration test (standard/ruggedized)	0.7 g/1.0 g
--------------------------------------	-------------

Relative humidity	5%–95% (IEC 721-3-3; Class 3K3 (non-condensing) during operation)
-------------------	---

Aggressive environment (IEC 60068-2-43) H ₂ S test	Class Kd
---	----------

Aggressive gases (IEC 60721-3-3)	Class 3C3
----------------------------------	-----------

Test method according to IEC 60068-2-43	H2S (10 days)
---	---------------

Ambient temperature (at SFAVM switching mode)	
---	--

- with derating	Maximum 55 °C (131 °F) ¹⁾
-----------------	--------------------------------------

- with full output power of typical EFF2 motors (up to 90% output current)	Maximum 50 °C (122 °F) ¹⁾
--	--------------------------------------

- at full continuous FC output current	Maximum 45 °C (113 °F) ¹⁾
--	--------------------------------------

Minimum ambient temperature during full-scale operation	0 °C (32 °F)
---	--------------

Minimum ambient temperature at reduced performance	-10 °C (14 °F)
--	----------------

Temperature during storage/transport	-25 to +65/70 °C (13 to 149/158 °F)
--------------------------------------	-------------------------------------

Maximum altitude above sea level without derating	1000 m (3281 ft)
---	------------------

Maximum altitude above sea level with derating	3000 m (9842 ft)
--	------------------

1) For more information on derating, see the design guide.

EMC standards, Emission	EN 61800-3
-------------------------	------------

EMC standards, Immunity	EN 61800-3
Energy efficiency class ¹⁾	IE2

1) Determined according to EN 50598-2 at:

- Rated load.
- 90% rated frequency.
- Switching frequency factory setting.
- Switching pattern factory setting.

10.5 Cable Specifications

Cable lengths and cross-sections for control cables

Maximum motor cable length, shielded	150 m (492 ft)
Maximum motor cable length, unshielded	300 m (984 ft)
Maximum cross-section to motor and mains	See chapter 10.1 Electrical Data, 380-480 V ¹⁾
Maximum cross-section to control terminals, rigid wire	1.5 mm ² /16 AWG (2x0.75 mm ²)
Maximum cross-section to control terminals, flexible cable	1 mm ² /18 AWG
Maximum cross-section to control terminals, cable with enclosed core	0.5 mm ² /20 AWG
Minimum cross-section to control terminals	0.25 mm ² /23 AWG

1) For power cables, see electrical data in chapter 10.1 Electrical Data, 380-480 V.

10.6 Control Input/Output and Control Data

Digital inputs

Programmable digital inputs	4 (6)
Terminal number	18, 19, 27 ¹⁾ , 29 ¹⁾ , 32, 33
Logic	PNP or NPN
Voltage level	0–24 V DC
Voltage level, logic 0 PNP	<5 V DC
Voltage level, logic 1 PNP	>10 V DC
Voltage level, logic 0 NPN	>19 V DC
Voltage level, logic 1 NPN	<14 V DC
Maximum voltage on input	28 V DC
Input resistance, R _i	Approximately 4 kΩ

All digital inputs are galvanically isolated from the supply voltage (PELV) and other high-voltage terminals.

1) Terminals 27 and 29 can also be programmed as outputs.

Analog inputs

Number of analog inputs	2
Terminal number	53, 54
Modes	Voltage or current
Mode select	Switches A53 and A54
Voltage mode	Switch A53/A54=(U)
Voltage level	0 V to +10 V (scaleable)
Input resistance, R _i	Approximately 10 kΩ
Maximum voltage	±20 V
Current mode	Switch A53/A54=(I)
Current level	0/4 to 20 mA (scaleable)
Input resistance, R _i	Approximately 200 Ω
Maximum current	30 mA
Resolution for analog inputs	10 bit (+ sign)
Accuracy of analog inputs	Maximum error 0.5% of full scale
Bandwidth	100 Hz

The analog inputs are galvanically isolated from the supply voltage (PELV) and other high-voltage terminals.

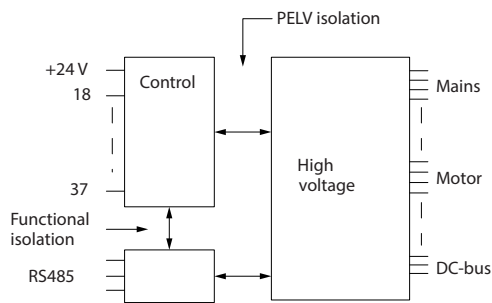

Illustration 10.1 PELV Isolation

Pulse inputs

Programmable pulse inputs	2
Terminal number pulse	29, 33
Maximum frequency at terminal 29, 33 (push-pull driven)	110 kHz
Maximum frequency at terminal 29, 33 (open collector)	5 kHz
Minimum frequency at terminal 29, 33	4 Hz
Voltage level	See <i>Digital Inputs</i> in chapter 10.6 Control Input/Output and Control Data
Maximum voltage on input	28 V DC
Input resistance, R_i	Approximately 4 k Ω
Pulse input accuracy (0.1–1 kHz)	Maximum error: 0.1% of full scale

Analog output

Number of programmable analog outputs	1
Terminal number	42
Current range at analog output	0/4–20 mA
Maximum resistor load to common at analog output	500 Ω
Accuracy on analog output	Maximum error: 0.8% of full scale
Resolution on analog output	8 bit

The analog output is galvanically isolated from the supply voltage (PELV) and other high-voltage terminals.

Control card, RS485 serial communication

Terminal number	68 (P, TX+, RX+), 69 (N, TX-, RX-)
Terminal number 61	Common for terminals 68 and 69

The RS485 serial communication circuit is functionally separated from other central circuits and galvanically isolated from the supply voltage (PELV).

Digital output

Programmable digital/pulse outputs	2
Terminal number	27, 29 ¹⁾
Voltage level at digital/frequency output	0–24 V
Maximum output current (sink or source)	40 mA
Maximum load at frequency output	1 k Ω
Maximum capacitive load at frequency output	10 nF
Minimum output frequency at frequency output	0 Hz
Maximum output frequency at frequency output	32 kHz
Accuracy of frequency output	Maximum error: 0.1% of full scale
Resolution of frequency outputs	12 bit

1) Terminals 27 and 29 can also be programmed as inputs.

The digital output is galvanically isolated from the supply voltage (PELV) and other high-voltage terminals.

Control card, 24 V DC output

Terminal number	12, 13
Maximum load	200 mA

The 24 V DC supply is galvanically isolated from the supply voltage (PELV), but has the same potential as the analog and digital inputs and outputs.

Relay outputs

Programmable relay outputs	2
Maximum cross-section to relay terminals	2.5 mm ² (12 AWG)
Minimum cross-section to relay terminals	0.2 mm ² (30 AWG)
Length of stripped wire	8 mm (0.3 in)
Relay 01 terminal number	1–3 (break), 1–2 (make)
Maximum terminal load (AC-1) ¹⁾ on 1–2 (NO) (Resistive load) ^{2), 3)}	400 V AC, 2 A
Maximum terminal load (AC-15) ¹⁾ on 1–2 (NO) (Inductive load @ cosφ 0.4)	240 V AC, 0.2 A
Maximum terminal load (DC-1) ¹⁾ on 1–2 (NO) (Resistive load)	80 V DC, 2 A
Maximum terminal load (DC-13) ¹⁾ on 1–2 (NO) (Inductive load)	24 V DC, 0.1 A
Maximum terminal load (AC-1) ¹⁾ on 1–3 (NC) (Resistive load)	240 V AC, 2 A
Maximum terminal load (AC-15) ¹⁾ on 1–3 (NC) (Inductive load @ cosφ 0.4)	240 V AC, 0.2 A
Maximum terminal load (DC-1) ¹⁾ on 1–3 (NC) (Resistive load)	50 V DC, 2 A
Maximum terminal load (DC-13) ¹⁾ on 1–3 (NC) (Inductive load)	24 V DC, 0.1 A
Minimum terminal load on 1–3 (NC), 1–2 (NO)	24 V DC 10 mA, 24 V AC 2 mA
Environment according to EN 60664-1	Overvoltage category III/pollution degree 2
Relay 02 terminal number	4–6 (break), 4–5 (make)
Maximum terminal load (AC-1) ¹⁾ on 4–5 (NO) (Resistive load) ^{2), 3)}	400 V AC, 2 A
Maximum terminal load (AC-15) ¹⁾ on 4–5 (NO) (Inductive load @ cosφ 0.4)	240 V AC, 0.2 A
Maximum terminal load (DC-1) ¹⁾ on 4–5 (NO) (Resistive load)	80 V DC, 2 A
Maximum terminal load (DC-13) ¹⁾ on 4–5 (NO) (Inductive load)	24 V DC, 0.1 A
Maximum terminal load (AC-1) ¹⁾ on 4–6 (NC) (Resistive load)	240 V AC, 2 A
Maximum terminal load (AC-15) ¹⁾ on 4–6 (NC) (Inductive load @ cosφ 0.4)	240 V AC, 0.2 A
Maximum terminal load (DC-1) ¹⁾ on 4–6 (NC) (Resistive load)	50 V DC, 2 A
Maximum terminal load (DC-13) ¹⁾ on 4–6 (NC) (Inductive load)	24 V DC, 0.1 A
Minimum terminal load on 4–6 (NC), 4–5 (NO)	24 V DC 10 mA, 24 V AC 2 mA
Environment according to EN 60664-1	Overvoltage category III/pollution degree 2

The relay contacts are galvanically isolated from the rest of the circuit by reinforced isolation (PELV).

1) IEC 60947 part 4 and 5.

2) Overvoltage Category II.

Control card, +10 V DC output

Terminal number	50
Output voltage	10.5 V ±0.5 V
Maximum load	25 mA

The 10 V DC supply is galvanically isolated from the supply voltage (PELV) and other high-voltage terminals.

Control characteristics

Resolution of output frequency at 0–1000 Hz	±0.003 Hz
System response time (terminals 18, 19, 27, 29, 32, 33)	≤2 m/s
Speed control range (open loop)	1:100 of synchronous speed
Speed accuracy (open loop)	30–4000 RPM: Maximum error of ±8 RPM

All control characteristics are based on a 4-pole asynchronous motor.

Control card performance

Scan interval	5 M/S
---------------	-------

Control card, USB serial communication

USB standard	1.1 (full speed)
USB plug	USB type B device plug

NOTICE

Connection to PC is carried out via a standard host/device USB cable.
 The USB connection is galvanically isolated from the supply voltage (PELV) and other high-voltage terminals.
 The USB connection is not galvanically isolated from ground. Use only isolated laptop/PC as connection to the USB connector on the drive or an isolated USB cable/converter.

10.7 Fuses and Circuit Breakers

Fuses ensure that possible damage to the drive is limited to damages inside the unit. To ensure compliance with EN 50178, use the recommended fuses as replacements. Use of fuses on the supply side is mandatory for IEC 60364 (CE) and NEC 2009 (UL) compliant installations.

J8–J9 recommended fuses

Type aR fuses are recommended for enclosures J8–J9. See *Table 10.3*.

Model	380–480 V
N90K	ar-315
N110	ar-315
N132	ar-350
N160	ar-400
N200	ar-500
N250	ar-630
N315	ar-800

Table 10.3 J8–J9 Power/semiconductor Fuse Sizes

Model	Fuse Options						
	Bussman	Littelfuse	Littelfuse	Bussmann	Siba	Ferraz-Shawmut	Ferraz-Shawmut (Europe)
N90K	170M2619	LA50QS300-4	L50S-300	FWH-300A	20 189 20.315	A50QS300-4	6,9URD31D08A0315
N110	170M2619	LA50QS300-4	L50S-300	FWH-300A	20 189 20.315	A50QS300-4	6,9URD31D08A0315
N132	170M2620	LA50QS350-4	L50S-350	FWH-350A	20 189 20.350	A50QS350-4	6,9URD31D08A0350
N160	170M2621	LA50QS400-4	L50S-400	FWH-400A	20 189 20.400	A50QS400-4	6,9URD31D08A0400
N200	170M4015	LA50QS500-4	L50S-500	FWH-500A	20 610 31.550	A50QS500-4	6,9URD31D08A0550
N250	170M4016	LA50QS600-4	L50S-600	FWH-600A	20 610 31.630	A50QS600-4	6,9URD31D08A0630
N315	170M4017	LA50QS800-4	L50S-800	FWH-800A	20 610 31.800	A50QS800-4	6,9URD32D08A0800

Table 10.4 J8–J9 Power/semiconductor Fuse Options, 380–480 V

Bussmann	Rating
LPJ-21/2SP	2.5 A, 600 V

Table 10.5 J8–J9 Space Heater Fuse Recommendation

NOTICE

DISCONNECT SWITCH

All units ordered and supplied with a factory-installed disconnect switch require Class L branch circuit fusing to meet the 100 kA SCCR for the drive. If a circuit breaker is used, the SCCR rating is 42 kA. The input voltage and power rating of the drive determines the specific Class L fuse. The input voltage and power rating is found on the product nameplate. For more information regarding the nameplate, see *chapter 4 Mechanical Installation*.

10.8 Fastener Tightening Torques

Apply the correct torque when tightening fasteners in the locations that are listed in *Table 10.6*. Too low or too high torque when fastening an electrical connection results in a bad electrical connection. To ensure correct torque, use a torque wrench.

Location	Bolt size	Torque [Nm (in-lb)]
Mains terminals	M10/M12	19 (168)/37 (335)
Motor terminals	M10/M12	19 (168)/37 (335)
Ground terminals	M8/M10	9.6 (84)/19.1 (169)
Relay terminals	–	0.5 (4)
Door/panel cover	M5	2.3 (20)
Gland plate	M5	2.3 (20)

Table 10.6 Fastener Torque Ratings

10.9 Enclosure Dimensions

10.9.1 J8 Exterior Dimensions

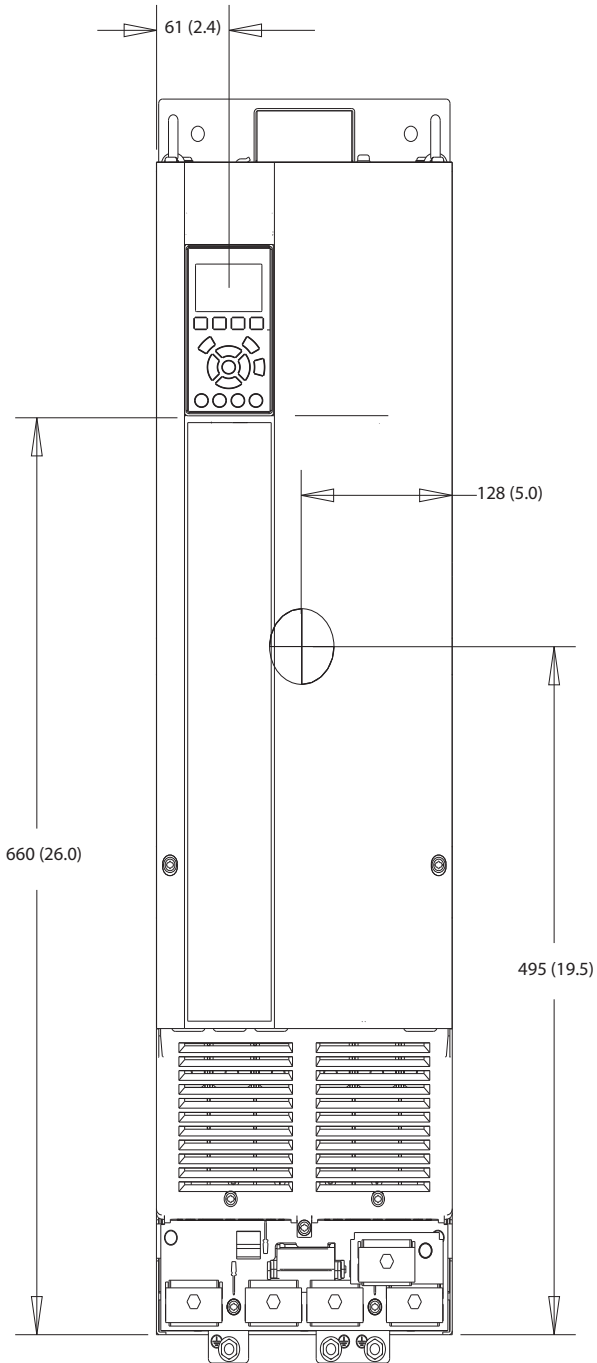

130BF322.10

Illustration 10.2 Front View of J8

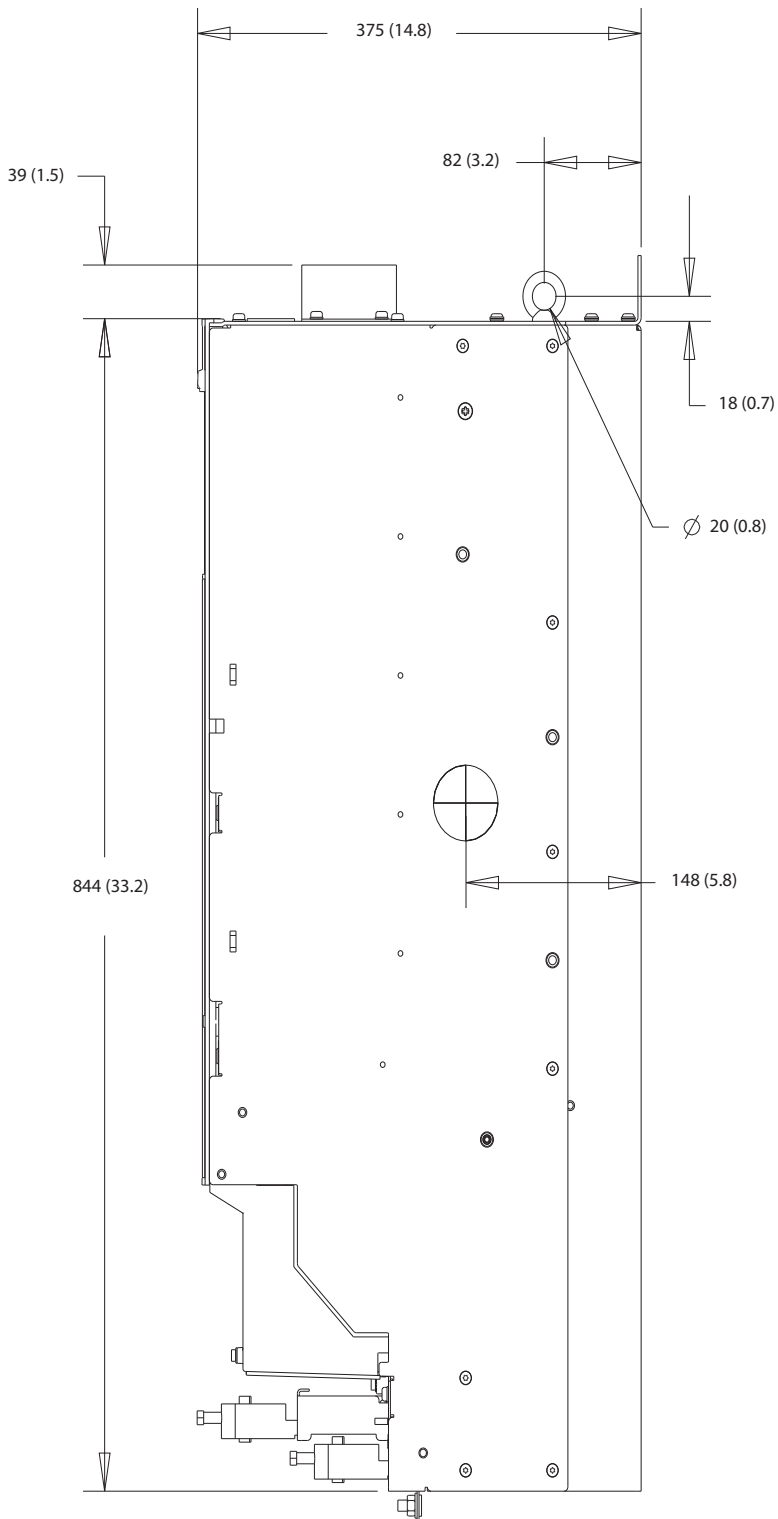

10

Illustration 10.3 Side View of J8

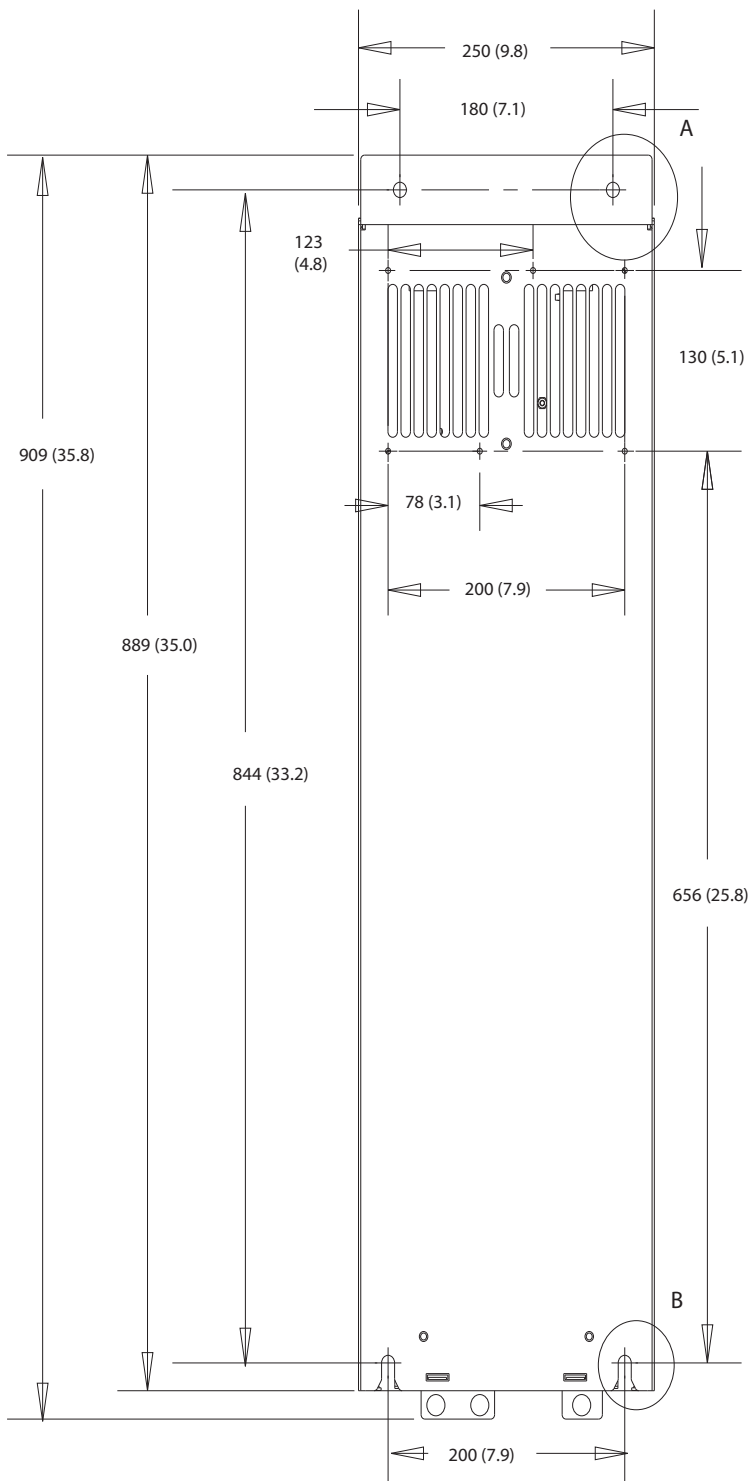

A

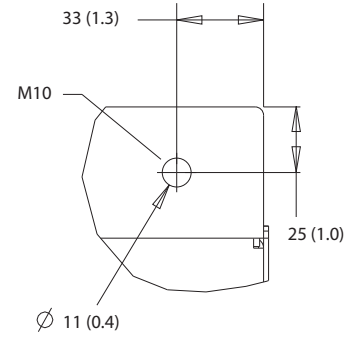

130BF802.10

B

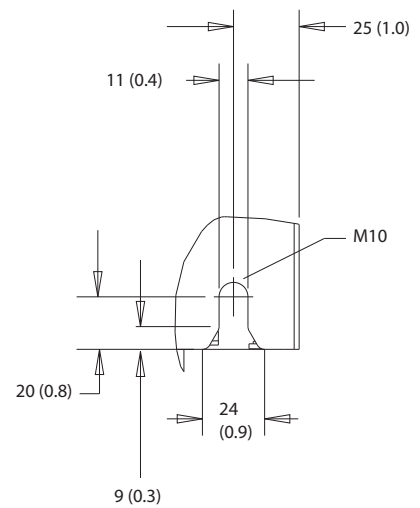

10

Illustration 10.4 Back View of J8

10.9.2 J9 Exterior Dimensions

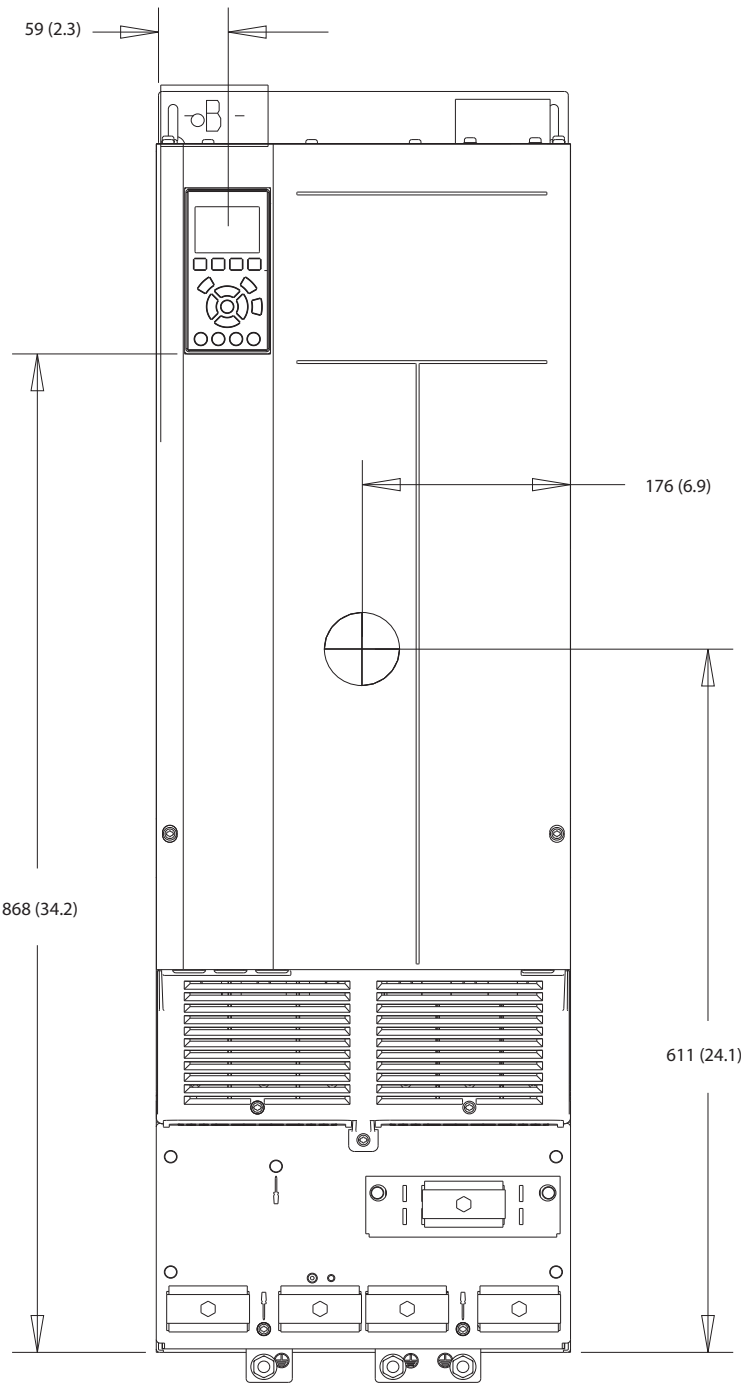

130BF323:10

10

Illustration 10.5 Front View of J9

130BF803.10

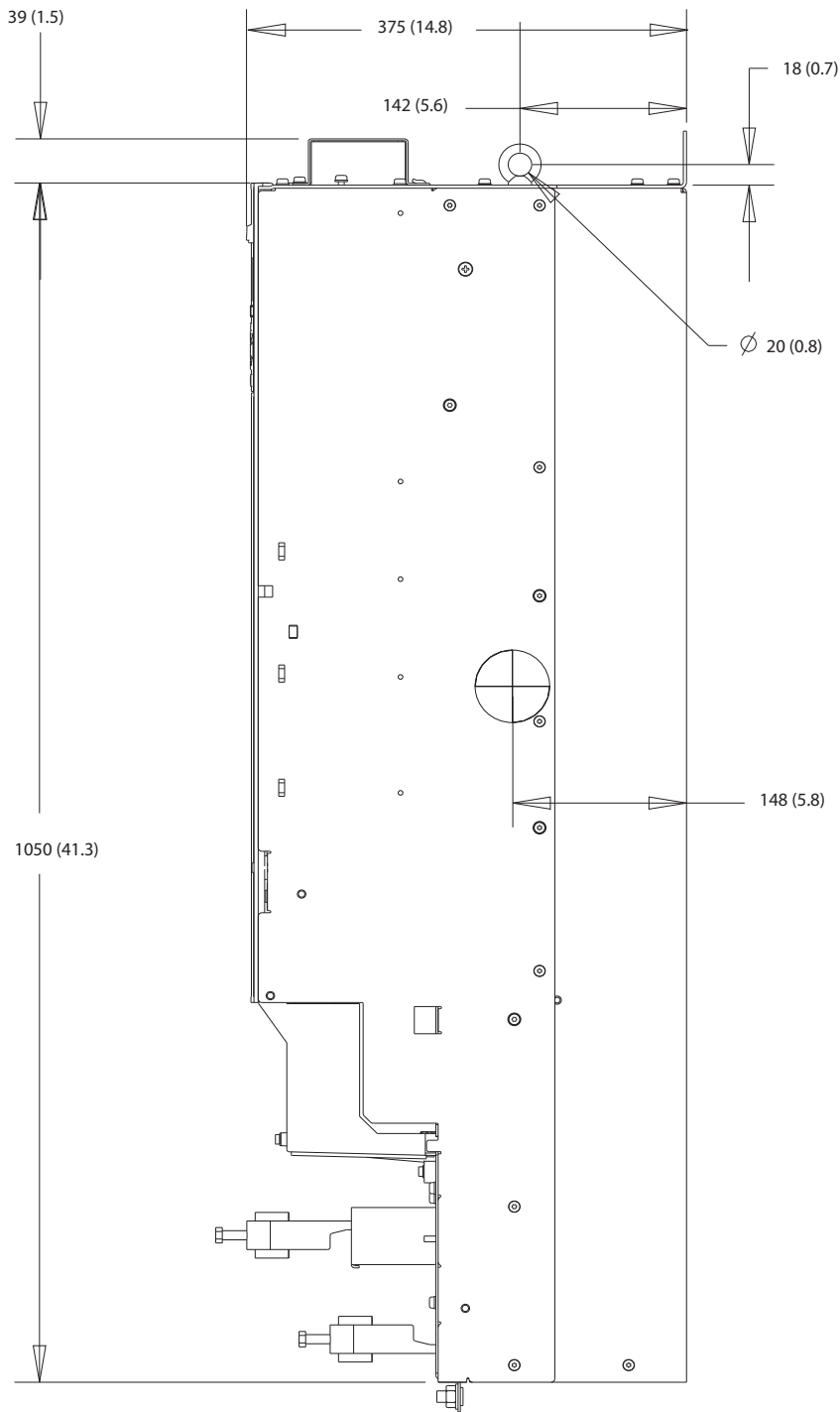

10

Illustration 10.6 Side View for J9

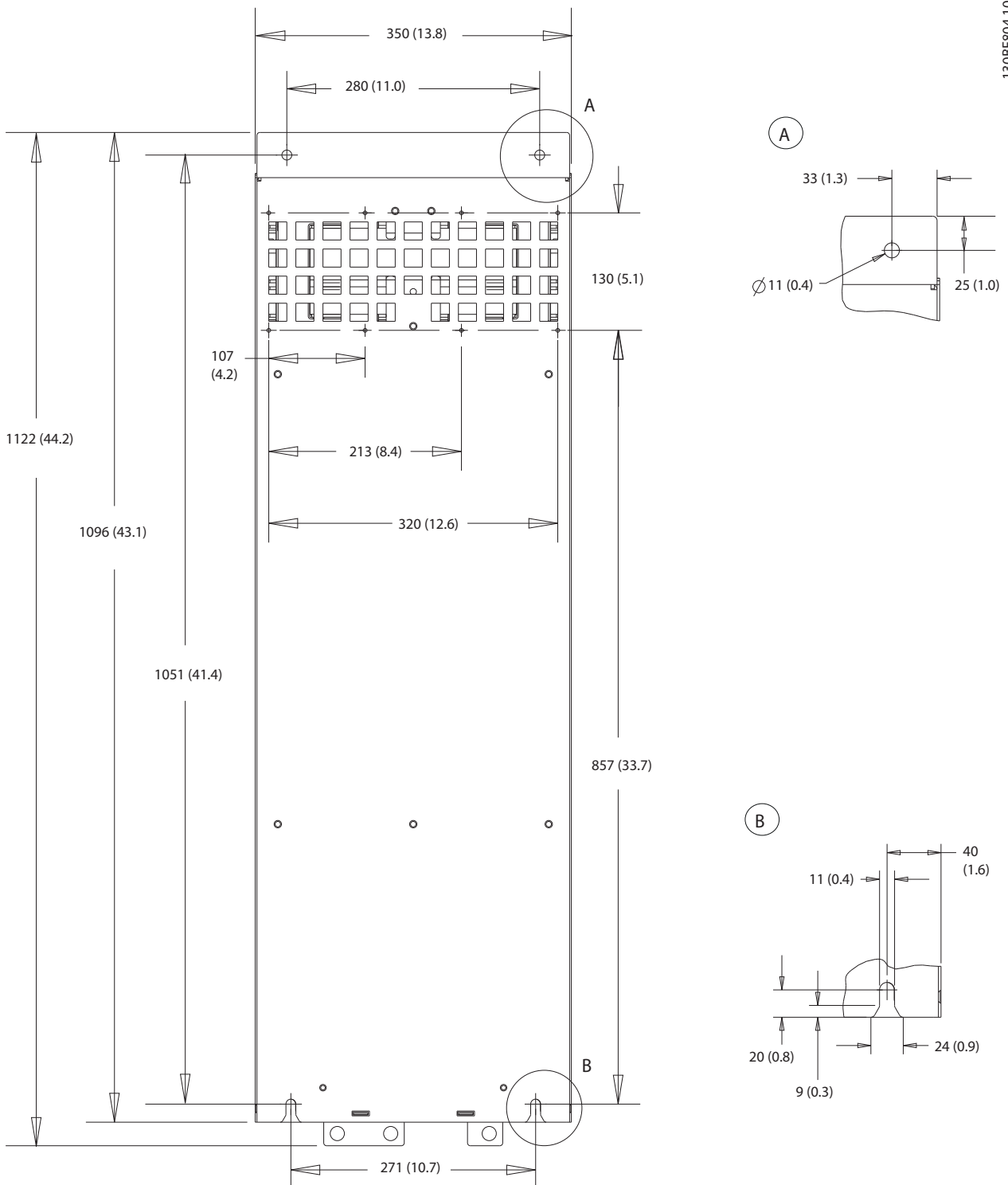

10

Illustration 10.7 Back View for J9

11 Appendix

11.1 Abbreviations and Conventions

°C	Degrees Celsius
°F	Degrees Fahrenheit
Ω	Ohm
AC	Alternating current
AEO	Automatic energy optimization
ACP	Application control processor
AMA	Automatic motor adaptation
AWG	American wire gauge
CPU	Central processing unit
CSIV	Customer-specific initialization values
CT	Current transformer
DC	Direct current
DVM	Digital voltmeter
EEPROM	Electrically erasable programmable read-only memory
EMC	Electromagnetic compatibility
EMI	Electromagnetic interference
ESD	Electrostatic discharge
ETR	Electronic thermal relay
$f_{M,N}$	Nominal motor frequency
HF	High frequency
HVAC	Heating, ventilation, and air conditioning
Hz	Hertz
I_{LIM}	Current limit
I_{INV}	Rated inverter output current
$I_{M,N}$	Nominal motor current
$I_{VLT,MAX}$	Maximum output current
$I_{VLT,N}$	Rated output current supplied by the drive
IEC	International electrotechnical commission
IGBT	Insulated-gate bipolar transistor
I/O	Input/output
IP	Ingress protection
kHz	Kilohertz
kW	Kilowatt
L_d	Motor d-axis inductance
L_q	Motor q-axis inductance
LC	Inductor-capacitor
LCP	Local control panel
LED	Light-emitting diode
LOP	Local operation pad
mA	Milliamp
MCB	Miniature circuit breakers
MCP	Motor control processor
mV	Millivolts
NEMA	National Electrical Manufacturers Association
NTC	Negative temperature coefficient
$P_{M,N}$	Nominal motor power
PCB	Printed circuit board

PE	Protective earth
PELV	Protective extra low voltage
PID	Proportional integral derivative
PLC	Programmable logic controller
P/N	Part number
PROM	Programmable read-only memory
PS	Power section
PTC	Positive temperature coefficient
PWM	Pulse width modulation
R_s	Stator resistance
RAM	Random-access memory
RCD	Residual current device
RFI	Radio frequency interference
RMS	Root means square (cyclically alternating electric current)
RPM	Revolutions per minute
SCR	Silicon controlled rectifier
SMPS	Switch mode power supply
S/N	Serial number
T_{LIM}	Torque limit
$U_{M,N}$	Nominal motor voltage
V	Volt
VVC	Voltage vector control
X_h	Motor main reactance

Table 11.1 Abbreviations, Acronyms, and Symbols

Conventions

- Numbered lists indicate procedures.
- Bullet lists indicate other information and description of illustrations.
- Italicized text indicates:
 - Cross reference
 - Link
 - Footnote
 - Parameter name
 - Parameter group name
 - Parameter option
- All dimensions are in mm (inch).

11.2 Parameter Menu Structure

0-0*	Operation / Display	1-3*	Adv. Motor Data	2-10	Brake Function	3-90	Step Size	5-31	Terminal 29 Digital Output
0-0*	Basic Settings	1-30	Stator Resistance (Rs)	2-16	AC brake Max. Current	3-91	Ramp Time	5-32	Term X30/6 Digi Out (MCB 101)
0-01	Language	1-31	Rotor Resistance (Rr)	2-17	Over-voltage Control	3-92	Power Restore	5-33	Term X30/7 Digi Out (MCB 101)
0-02	Motor Speed Unit	1-33	Stator Leakage Reactance (X1)	2-19	Over-voltage Gain	3-93	Maximum Limit	5-34*	Relays
0-04	Operating State at Power-up (Hand)	1-34	Rotor Leakage Reactance (X2)	3-**	Reference / Ramps	3-94	Minimum Limit	5-40	Function Relay
0-1*	Set-up Operations	1-35	Main Reactance (Xh)	3-0*	Reference Limits	3-95	Ramp Delay	5-41	On Delay Relay
0-10	Active Set-up	1-36	Iron Loss Resistance (Rfe)	3-00	Reference Range	4-**	Limits / Warnings	5-42	Off Delay Relay
0-11	Edit Set-up	1-37	d-axis Inductance (Ld)	3-01	Reference/Feedback Unit	4-1*	Motor Limits	5-5*	Pulse Input
0-12	This Set-up Linked to	1-38	q-axis Inductance (Lq)	3-02	Minimum Reference	4-10	Motor Speed Direction	5-50	Term. 29 Low Frequency
0-13	Readout: Linked Set-ups	1-39	Motor Poles	3-03	Maximum Reference	4-11	Motor Speed Low Limit [RPM]	5-51	Term. 29 High Frequency
0-14	Readout: Edit Set-ups / Channel	1-40	Back EMF at 1000 RPM	3-04	Reference Function	4-12	Motor Speed Low Limit [Hz]	5-52	Term. 29 Low Ref./Feedb. Value
0-2*	LCP Display	1-41	Motor Angle Offset	3-1*	References	4-13	Motor Speed High Limit [RPM]	5-53	Term. 29 High Ref./Feedb. Value
0-20	Display Line 1.1 Small	1-46	Position Detection Gain	3-10	Preset Reference	4-14	Motor Speed High Limit [Hz]	5-54	Pulse Filter Time Constant #29
0-21	Display Line 1.2 Small	1-47	Torque Calibration	3-11	Jog Speed [Hz]	4-16	Torque Limit Motor Mode	5-55	Term. 33 Low Frequency
0-22	Display Line 1.3 Small	1-5*	Load Indep. Setting	3-12	Catch up/slow Down Value	4-17	Torque Limit Generator Mode	5-56	Term. 33 High Frequency
0-23	Display Line 2 Large	1-50	Motor Magnetisation at Zero Speed	3-13	Reference Site	4-18	Current Limit	5-57	Term. 33 Low Ref./Feedb. Value
0-24	Display Line 3 Large	1-51	Min Speed Normal Magnetising [RPM]	3-14	Preset Relative Reference	4-19	Max Output Frequency	5-58	Term. 33 High Ref./Feedb. Value
0-25	My Personal Menu	1-52	Min Speed Normal Magnetising [Hz]	3-15	Reference Resource 1	4-2*	Limit Factors	5-59	Pulse Filter Time Constant #33
0-3*	LCP Custom Readout	1-55	U/f Characteristic - F	3-16	Reference Resource 2	4-20	Torque Limit Factor Source	5-6*	Pulse Output
0-30	Unit for User-defined Readout	1-56	U/f Characteristic - U	3-17	Reference Resource 3	4-21	Speed Limit Factor Source	5-60	Terminal 27 Pulse Output Variable
0-31	Min Value of User-defined Readout	1-58	Flying Start Test Pulses Current	3-18	Relative Scaling Reference Resource	4-3*	Motor Fb Monitor	5-62	Pulse Output Max Freq #27
0-32	Max Value of User-defined Readout	1-59	Flying Start Test Pulses Frequency	3-19	Jog Speed [RPM]	4-30	Motor Feedback Loss Function	5-63	Terminal 29 Pulse Output Variable
0-37	Display Text 1	1-6*	Load Depen. Setting	3-4*	Ramp 1	4-31	Motor Feedback Speed Error	5-66	Pulse Output Max Freq #29
0-38	Display Text 2	1-60	Low Speed Load Compensation	3-40	Ramp 1 Type	4-32	Motor Feedback Loss Timeout	5-68	Terminal X30/6 Pulse Output Variable
0-39	Display Text 3	1-61	High Speed Load Compensation	3-41	Ramp 1 Ramp Up Time	4-4*	Speed Monitor	5-71	Pulse Output Max Freq #X30/6
0-4*	LCP keypad	1-62	Slip Compensation	3-42	Ramp 1 Ramp Down Time	4-40	Warning Freq. Low	5-7*	24V Encoder Input
0-40	[Hand on] Key on LCP	1-63	Slip Compensation Time Constant	3-45	Ramp 1 S-ramp Ratio at Accel. Start	4-41	Warning Freq. High	5-70	Term 32/33 Pulses Per Revolution
0-41	[Off] Key on LCP	1-64	Resonance Damping	3-46	Ramp 1 S-ramp Ratio at Accel. End	4-5*	Adj. Warnings	5-71	Term 32/33 Encoder Direction
0-42	[Auto on] Key on LCP	1-65	Resonance Damping Time Constant	3-47	Ramp 1 S-ramp Ratio at Decel. Start	4-50	Warning Current Low	5-9*	Bus Controlled
0-43	[Reset] Key on LCP	1-66	Min. Current at Low Speed	3-48	Ramp 1 S-ramp Ratio at Decel. End	4-51	Warning Current High	5-90	Digital & Relay Bus Control
0-5*	Copy/Save	1-7*	Start Adjustments	3-5*	Ramp 2	4-52	Warning Speed Low	5-93	Pulse Out #27 Bus Control
0-50	LCP Copy	1-70	Start Mode	3-50	Ramp 2 Type	4-53	Warning Speed High	5-94	Pulse Out #27 Timeout Preset
0-51	Set-up Copy	1-71	Start Delay	3-51	Ramp 2 Ramp Up Time	4-54	Warning Reference Low	5-95	Pulse Out #29 Bus Control
0-6*	Password	1-72	Start Function	3-52	Ramp 2 Ramp Down Time	4-55	Warning Reference High	5-96	Pulse Out #29 Timeout Preset
0-60	Main Menu Password	1-73	Flying Start	3-55	Ramp 2 S-ramp Ratio at Accel. Start	4-56	Warning Feedback Low	5-97	Pulse Out #X30/6 Bus Control
0-61	Access to Main Menu w/o Password	1-74	Start Speed [RPM]	3-56	Ramp 2 S-ramp Ratio at Accel. End	4-57	Warning Feedback High	5-98	Pulse Out #X30/6 Timeout Preset
1-**	Load and Motor	1-75	Start Speed [Hz]	3-57	Ramp 2 S-ramp Ratio at Decel. Start	4-6*	Speed Bypass	6-**	Analog In/Out
1-0*	General Settings	1-76	Start Current	3-58	Ramp 2 S-ramp Ratio at Decel. End	4-60	Bypass Speed From [RPM]	6-0*	Live Zero Timeout Time
1-00	Configuration Mode	1-77	Compressor Start Max Speed [RPM]	3-6*	Ramp 3	4-61	Bypass Speed From [Hz]	6-01	Live Zero Timeout Function
1-01	Motor Control Principle	1-78	Compressor Start Max Speed [Hz]	3-60	Ramp 3 Type	4-61	Bypass Speed To [RPM]	6-1*	Analog Input 1
1-03	Torque Characteristics	1-79	Compressor Start Max Time to Trip	3-61	Ramp 3 Ramp up Time	4-62	Bypass Speed To [Hz]	6-10	Terminal 53 Low Voltage
1-04	Overload Mode	1-8*	Stop Adjustments	3-62	Ramp 3 Ramp down Time	5-**	Digital In/Out	6-11	Terminal 53 High Voltage
1-05	Local Mode Configuration	1-81	Function at Stop	3-65	Ramp 3 S-ramp Ratio at Accel. Start	5-0*	Digital I/O Mode	6-12	Terminal 53 Low Current
1-06	Clockwise Direction	1-82	Min Speed for Function at Stop [RPM]	3-66	Ramp 3 S-ramp Ratio at Accel. End	5-00	Digital I/O Mode	6-13	Terminal 53 High Current
1-1*	Special Settings	1-82	Min Speed for Function at Stop [Hz]	3-67	Ramp 3 S-ramp Ratio at Decel. Start	5-01	Terminal 27 Mode	6-14	Terminal 53 Low Ref./Feedb. Value
1-10	Motor Construction	1-9*	Motor Temperature	3-68	Ramp 3 S-ramp Ratio at Decel. End	5-02	Terminal 29 Mode	6-15	Terminal 53 High Ref./Feedb. Value
1-14	Damping Gain	1-90	Motor Thermal Protection	3-7*	Ramp 4	5-02	Digital Inputs	6-16	Terminal 53 Filter Time Constant
1-15	Low Speed Filter Time Const.	1-91	Motor External Fan	3-70	Ramp 4 Type	5-1*	Digital In/Out	6-2*	Analog Input 2
1-16	High Speed Filter Time Const.	1-93	Thermistor Resource	3-71	Ramp 4 Ramp up Time	5-10	Terminal 18 Digital Input	6-20	Terminal 54 Low Voltage
1-17	Voltage filter time const.	2-**	Brakes	3-72	Ramp 4 Ramp down Time	5-11	Terminal 19 Digital Input	6-21	Terminal 54 High Voltage
1-18	Min. Current at No Load	2-0*	DC-Brake	3-75	Ramp 4 S-ramp Ratio at Accel. Start	5-12	Terminal 29 Digital Input	6-22	Terminal 54 Low Current
1-20	Motor Power [kW]	2-01	DC Hold Current	3-76	Ramp 4 S-ramp Ratio at Accel. End	5-13	Terminal 29 Digital Input	6-23	Terminal 54 High Current
1-22	Motor Voltage	2-02	DC Braking Current	3-77	Ramp 4 S-ramp Ratio at Decel. Start	5-14	Terminal 32 Digital Input	6-24	Terminal 54 Low Ref./Feedb. Value
1-23	Motor Frequency	2-03	DC Brake Cut In Speed [RPM]	3-78	Ramp 4 S-ramp Ratio at Decel. End	5-15	Terminal 33 Digital Input	6-25	Terminal 54 High Ref./Feedb. Value
1-24	Motor Current	2-04	DC Brake Cut In Speed [Hz]	3-8*	Other Ramps	5-16	Terminal X30/3 Digital Input	6-26	Terminal 54 Filter Time Constant
1-25	Motor Nominal Speed	2-06	Parking Current	3-80	Jog Ramp Time	5-17	Terminal X30/4 Digital Input	6-3*	Analog Input 3
1-26	Motor Cont. Rated Torque	2-07	Parking Time	3-81	Quick Stop Ramp Time	5-18	Terminal X30/4 Digital Input	6-30	Terminal X30/11 Low Voltage
1-29	Automatic Motor Adaptation (AMA)	2-1*	Brake Energy Funct.	3-9*	Digital Pot.Meter	5-30	Terminal 27 Digital Output	6-31	Terminal X30/11 High Voltage

6-34	Term. X30/11 Low Ref./Feedb. Value	7-5*	Adv. Process PID II	8-91	Bus Jog 2 Speed	12-80	FTP Server	14-26	Trip Delay at Inverter Fault
6-35	Term. X30/11 High Ref./Feedb. Value	7-50	Process PID Extended PID	9-00	PROFdrive	12-81	HTTP Server	14-3*	Current Limit Ctrl.
6-36	Term. X30/11 Filter Time Constant	7-51	Process PID Feed Fwd Gain	9-00	Setpoint	12-82	SMTP Service	14-30	Current Lim Ctrl, Proportional Gain
6-4*	Analog Input 4	7-52	Process PID Feed Fwd Ramp up	9-07	Actual Value	12-83	SNMP Agent	14-31	Current Lim Ctrl, Integration Time
6-41	Terminal X30/12 Low Voltage	7-53	Process PID Feed Fwd Ramp down	9-15	PCD Write Configuration	12-84	PCD Address Conflict Detection	14-32	Current Lim Ctrl, Filter Time
6-42	Terminal X30/12 High Voltage	7-56	Process PID Ref. Filter Time	9-16	PCD Read Configuration	12-85	ACD Last Conflict	14-4*	Energy Optimising
6-44	Term. X30/12 Low Ref./Feedb. Value	7-57	Process PID Fb. Filter Time	9-18	Node Address	12-89	Transparent Socket Channel Port	14-40	VT Level
6-45	Term. X30/12 High Ref./Feedb. Value	7-6*	Feedback Conversion	9-19	Drive Unit System Number	12-9*	Advanced Ethernet Services	14-41	AEO Minimum Magnetisation
6-46	Term. X30/12 Filter Time Constant	7-60	Feedback 1 Conversion	9-22	Telegram Selection	12-90	Cable Diagnostic	14-42	Minimum AEO Frequency
6-50	Analog Output 1	7-62	Feedback 2 Conversion	9-23	Parameters for Signals	12-91	Auto Cross Over	14-43	Motor Cosphi
6-51	Terminal 42 Output Min Scale	8-0*	Comm. and Options	9-27	Parameter Edit	12-92	IGMP Snooping	14-5*	Environment
6-52	Terminal 42 Output Max Scale	8-0*	General Settings	9-28	Process Control	12-93	Cable Error Length	14-50	RFI Filter
6-53	Term 42 Output Bus Ctrl	8-01	Control Site	9-44	Fault Message Counter	12-94	Broadcast Storm Protection	14-51	DC-Link Compensation
6-54	Terminal 42 Output Timeout Preset	8-03	Control Word Source	9-45	Fault Message Counter	12-95	Inactivity timeout	14-52	Fan Control
6-55	Analog Output Filter	8-04	Control Word Timeout Time	9-47	Fault Number	12-96	Port Config	14-53	Fan Monitor
6-6*	Analog Output 2	8-05	Control Word Timeout Function	9-52	Fault Situation Counter	12-97	QoS Priority	14-55	Output Filter
6-60	Terminal X30/8 Output	8-06	Reset Control Word Timeout	9-63	Actual Baud Rate	12-99	Media Counters	14-59	Actual Number of Inverter Units
6-61	Terminal X30/8 Min. Scale	8-07	Diagnosis Trigger	9-64	Device Identification	13-1*	Smart Logic	14-6*	Auto Derate
6-62	Terminal X30/8 Max. Scale	8-08	Readout Filtering	9-65	Profile Number	13-0*	SLC Settings	14-60	Function at Over Temperature
6-63	Terminal X30/8 Bus Control	8-1*	Ctrl. Word Settings	9-67	Control Word 1	13-01	SL Controller Mode	14-61	Function at Inverter Overload
6-64	Terminal X30/8 Output Timeout Preset	8-10	Control Word Profile	9-68	Status Word 1	13-02	Start Event	14-62	Inv. Overload Derate Current
7-0*	Controllers	8-13	Configurable Status Word STW	9-70	Edit Set-up	13-03	Reset SLC	14-8*	Options
7-0*	Speed PID Ctrl.	8-14	Configurable Control Word CTW	9-71	Profibus Save Data Values	13-03	Reset SLC	14-9*	Fault Settings
7-00	Speed PID Feedback Source	8-19	Product Code	9-72	ProfibusDriveReset	13-1*	Comparators	14-90	Fault Level
7-02	Speed PID Proportional Gain	8-3*	FC Port Settings	9-75	DO Identification	13-10	Comparator Operand	15-5*	Drive Information
7-03	Speed PID Integral Time	8-30	Protocol	9-80	Defined Parameters (1)	13-11	Comparator Operator	15-0*	Operating Data
7-04	Speed PID Differentiation Time	8-31	Address	9-81	Defined Parameters (2)	13-12	Comparator Value	15-00	Operating Hours
7-05	Speed PID Diff. Gain Limit	8-32	FC Port Baud Rate	9-82	Defined Parameters (3)	13-2*	Timers	15-01	Running Hours
7-06	Speed PID Lowpass Filter Time	8-33	Parity / Stop Bits	9-83	Defined Parameters (4)	13-20	SL Controller Timer	15-02	kWh Counter
7-07	Speed PID Feedback Gear Ratio	8-34	Estimated cycle time	9-84	Defined Parameters (5)	13-4*	Logic Rules	15-03	Power Up's
7-08	Speed PID Feed Forward Factor	8-35	Minimum Response Delay	9-85	Defined Parameters (6)	13-40	Logic Rule Boolean 1	15-04	Over Temp's
7-1*	Torque PI Ctrl.	8-36	Max Response Delay	9-90	Changed Parameters (1)	13-41	Logic Rule Operator 1	15-05	Over Volt's
7-12	Torque PI Proportional Gain	8-37	Max Inter-Char Delay	9-91	Changed Parameters (2)	13-42	Logic Rule Boolean 2	15-06	Reset kWh Counter
7-13	Torque PI Integration Time	8-4*	FC MC protocol set	9-92	Changed Parameters (3)	13-43	Logic Rule Operator 2	15-07	Reset Running Hours Counter
7-2*	Process Ctrl. Feedb	8-40	Telegram Selection	9-93	Changed Parameters (4)	13-44	Logic Rule Boolean 3	15-1*	Data Log Settings
7-20	Process CL Feedback 1 Resource	8-41	Parameters for Signals	9-94	Changed Parameters (5)	13-5*	States	15-10	Logging Source
7-22	Process CL Feedback 2 Resource	8-42	PCD Write Configuration	9-99	Profibus Revision Counter	13-51	SL Controller Event	15-11	Logging Interval
7-3*	Process PID Ctrl.	8-43	PCD Read Configuration	12-8*	Ethernet	13-52	SL Controller Action	15-12	Trigger Event
7-30	Process PID Normal/ Inverse Control	8-5*	Digital/Bus	12-0*	IP Settings	14-0*	Special Functions	15-13	Logging Mode
7-31	Process PID Anti Windup	8-50	Coasting Select	12-00	IP Address Assignment	14-0*	Inverter Switching	15-14	Samples Before Trigger
7-32	Process PID Start Speed	8-51	Quick Stop Select	12-01	IP Address	14-00	Switching Pattern	15-2*	Historic Log
7-33	Process PID Proportional Gain	8-52	DC Brake Select	12-02	Subnet Mask	14-01	Switching Frequency	15-20	Historic Log: Event
7-34	Process PID Integral Time	8-53	Start Select	12-03	Default Gateway	14-03	Overmodulation	15-21	Historic Log: Value
7-35	Process PID Differentiation Time	8-54	Reversing Select	12-04	DHCP Server	14-04	Acoustic Noise Reduction	15-22	Historic Log: Time
7-36	Process PID Diff. Gain Limit	8-55	Set-up Select	12-05	Lease Expires	14-06	Dead Time Compensation	15-3*	Fault Log
7-38	Process PID Feed Forward Factor	8-56	Preset Reference Select	12-06	Name Servers	14-1*	Mains Failure	15-30	Fault Log: Error Code
7-39	On Reference Bandwidth	8-57	Profidrive OFF2 Select	12-07	Domain Name	14-10	Mains Failure	15-31	Fault Log: Value
7-4*	Adv. Process PID I	8-58	Profidrive OFF3 Select	12-08	Host Name	14-11	Mains Fault Voltage Level	15-32	Fault Log: Time
7-40	Process PID I-part Reset	8-8*	FC Port Diagnostics	12-09	Physical Address	14-12	Response to Mains Imbalance	15-4*	Drive Identification
7-41	Process PID Output Neg. Clamp	8-80	Bus Message Count	12-1*	Ethernet Link Parameters	14-14	Kin. Back-up Time-out	15-40	FC Type
7-42	Process PID Output Pos. Clamp	8-81	Bus Error Count	12-11	Link Status	14-15	Kin. Back-up Trip Recovery Level	15-41	Power Section
7-43	Process PID Gain Scale at Min. Ref.	8-82	Slave Messages Rcvd	12-12	Link Duration	14-16	Kin. Back-up Gain	15-42	Voltage
7-44	Process PID Gain Scale at Max. Ref.	8-83	Slave Error Count	12-12	Auto Negotiation	14-2*	Trip Reset	15-43	Software Version
7-45	Process PID Feed Fwd Resource/ Inv.	8-84	Slave Messages Sent	12-13	Link Speed	14-20	Reset Mode	15-44	Ordered Typecode String
7-46	Process PID Feed Fwd Normal/ Inv. Ctrl.	8-85	Slave Timeout Errors	12-14	Link Duplex	14-21	Automatic Restart Time	15-45	Actual Typecode String
7-48	PCD Feed Forward	8-88	Reset FC port Diagnostics	12-18	Supervisor MAC	14-22	Operation Mode	15-46	Frequency Converter Ordering No
7-49	Process PID Output Normal/ Inv. Ctrl.	8-9*	Bus Jog	12-19	Supervisor IP Addr.	14-24	Trip Delay at Current Limit	15-47	Power Card Ordering No
		8-90	Bus Jog 1 Speed	12-8*	Other Ethernet Services	14-25	Trip Delay at Torque Limit	15-48	LCP Id No

15-49 SW ID Control Card	16-6* Inputs & Outputs	21-10 Ext. 1 Ref./Feedback Unit
15-50 SW ID Power Card	16-60 Digital Input	21-11 Ext. 1 Minimum Reference
15-51 Frequency Converter Serial Number	16-61 Terminal 53 Switch Setting	21-12 Ext. 1 Maximum Reference
15-53 Power Card Serial Number	16-62 Analog Input 53	21-13 Ext. 1 Reference Source
15-54 Config File Name	16-63 Terminal 54 Switch Setting	21-14 Ext. 1 Feedback Source
15-59 Filename	16-64 Analog Input 54	21-15 Ext. 1 Setpoint
15-6* Option Ident	16-65 Analog Output 42 [mA]	21-17 Ext. 1 Reference [Unit]
15-60 Option Mounted	16-66 Digital Output [bin]	21-18 Ext. 1 Feedback [Unit]
15-61 Option SW Version	16-67 Freq. Input #29 [Hz]	21-19 Ext. 1 Output [%]
15-62 Option Ordering No	16-68 Freq. Input #33 [Hz]	21-2* Ext. CL 1 PID
15-63 Option Serial No	16-69 Pulse Output #27 [Hz]	21-20 Ext. 1 Normal/Inverse Control
15-8* Operating Data II	16-70 Pulse Output #29 [Hz]	21-21 Ext. 1 Proportional Gain
15-80 Fan Running Hours	16-71 Relay Output [bin]	21-22 Ext. 1 Integral Time
15-81 Preset Fan Running Hours	16-72 Counter A	21-23 Ext. 1 Differentiation Time
15-9* Parameter Info	16-73 Counter B	21-24 Ext. 1 Dif. Gain Limit
15-92 Defined Parameters	16-75 Analog In X30/11	22-0* Appl. Functions
15-93 Modified Parameters	16-76 Analog In X30/12	22-0* Miscellaneous
16-0* Data Readouts	16-77 Analog Out X30/8 [mA]	22-00 External Interlock Delay
16-0* General Status	16-8* Fieldbus & FC Port	22-4* Sleep Mode
16-00 Control Word	16-80 Fieldbus CTW 1	22-40 Minimum Run Time
16-01 Reference [Unit]	16-82 Fieldbus REF 1	22-41 Minimum Sleep Time
16-02 Reference %	16-84 Comm. Option STW	22-42 Wake-up Speed [RPM]
16-03 Status Word	16-85 FC Port CTW 1	22-43 Wake-up Speed [Hz]
16-05 Main Actual Value [%]	16-86 FC Port REF 1	22-44 Wake-up Ref./FB Difference
16-09 Custom Readout	16-87 Bus Readout Alarm/Warning	22-45 Setpoint Boost
16-1* Motor Status	16-9* Diagnosis Readouts	22-46 Maximum Boost Time
16-10 Power [kW]	16-90 Alarm Word	22-6* Broken Belt Detection
16-11 Power [hp]	16-91 Alarm Word 2	22-60 Broken Belt Function
16-12 Motor Voltage	16-92 Warning Word	22-61 Broken Belt Torque
16-13 Frequency	16-93 Warning Word 2	22-62 Broken Belt Delay
16-14 Motor current	16-94 Ext. Status Word	30-2* Special Features
16-15 Frequency [%]	16-95 Ext. Status Word 2	30-2* Adv. Start Adjust
16-16 Torque [Nm]	16-97 Alarm Word 3	30-20 High Starting Torque Time [s]
16-17 Speed [RPM]	17-0* Position Feedback	30-21 High Starting Torque Current [%]
16-18 Motor Thermal	17-1* Inc. Enc. Interface	30-22 Locked Rotor Protection
16-20 Motor Angle	17-10 Signal Type	30-23 Locked Rotor Detection Time [s]
16-21 Torque [%] High Res.	17-11 Resolution [PPR]	30-24 Locked Rotor Detection Speed Error [%]
16-22 Torque [%]	17-5* Resolver Interface	40-0* Special Settings
16-24 Calibrated Stator Resistance	17-50 Poles	40-4* Extend. Fault Log
16-3* Drive Status	17-51 Input Voltage	40-40 Fault Log: Ext. Reference
16-30 DC Link Voltage	17-52 Input Frequency	40-41 Fault Log: Frequency
16-34 Heatsink Temp.	17-53 Transformation Ratio	40-42 Fault Log: Current
16-35 Inverter Thermal	17-56 Encoder Sim. Resolution	40-43 Fault Log: Voltage
16-36 Inv. Nom. Current	17-59 Resolver Interface	40-44 Fault Log: DC Link Voltage
16-37 Inv. Max. Current	17-6* Monitoring and App.	40-45 Fault Log: Control Word
16-38 SL Controller State	17-60 Feedback Direction	40-46 Fault Log: Status Word
16-39 Control Card Temp.	17-61 Feedback Signal Monitoring	
16-40 Logging Buffer Full	18-0* Data Readouts 2	
16-45 Motor Phase U Current	18-5* Active Alarms/Warnings	
16-46 Motor Phase V Current	18-55 Active Alarm Numbers	
16-47 Motor Phase W Current	18-56 Active Warning Numbers	
16-48 Speed Ref. After Ramp [RPM]	18-9* PID Readouts	
16-49 Current Fault Source	18-90 Process PID Error	
16-5* Ref. & Feeds	18-91 Process PID Output	
16-50 External Reference	18-92 Process PID Clamped Output	
16-51 Pulse Reference	18-93 Process PID Gain Scaled Output	
16-52 Feedback[Unit]	21-0* Ext. Closed Loop	
16-53 Digi Pot Reference	21-1* Ext. CL 1 Ref./Fb.	
16-57 Feedback [RPM]		

Index

A	
Abbreviations.....	73
AC mains.....	26
see also <i>Mains</i>	
Additional resources.....	3
Alarms	
List of.....	11, 48
Log.....	11
Types of.....	47
Ambient conditions	
Specifications.....	61
Analog	
Input specifications.....	62
Output specifications.....	63
Analog input/output	
Descriptions and default settings.....	33
Approval and certification.....	3
Authorized personnel.....	4
Auto on.....	11, 45
Automatic energy optimization.....	38
Automatic motor adaptation (AMA)	
Configuring.....	38
Warning.....	52
B	
Burst transient.....	22
Bus termination switch.....	35
C	
Cables	
Installation warning.....	18
Maximum number and size per phase.....	59
Routing.....	32, 36
Shielded.....	18
Specifications.....	59, 62
Capacitor storage.....	13
Circuit breakers.....	36
Clearance requirement.....	15
Condensation.....	14
Control	
Characteristics.....	64
Wiring.....	22
Control card	
Overtemperature trip point.....	59
RS485 specifications.....	63
Specifications.....	64
Warning.....	53
Control input/output	
Descriptions and default settings.....	32
Control shelf.....	9
Control wiring.....	32, 34, 36
Cooling	
Check list.....	36
Cooling.....	15
Dust warning.....	14
Current	
Input.....	35
Leakage.....	22
Limit.....	57
D	
Definitions	
Status messages.....	45
Derating	
Specifications.....	61
Digital	
Input specifications.....	62
Output specifications.....	63
Digital input/output	
Descriptions and default settings.....	33
Dimension, shipping.....	6
Dimensions	
J8 exterior.....	67
J8 terminal.....	28
J9 exterior.....	70
J9 terminal.....	30
Discharge time.....	4
Disconnect.....	65
Disconnect switch.....	37
Disposal instruction.....	3
Drive	
Definition.....	6
Initialization.....	40
Lifting.....	16
Status.....	45
E	
Efficiency	
Specifications.....	59
Electrical specifications 380–480 V.....	60
Electronic thermal relay (ETR).....	18
EMC.....	18, 19, 20
Encoder.....	39
Energy efficiency class.....	61
Environment.....	61
Exterior dimensions	
J8.....	67
J9.....	70
External alarm reset.....	43
F	
Factory default settings.....	40

Fans		Installation environment.....	14
Servicing.....	14	Interference	
Warning.....	54	EMC.....	19
Fastener torque rating.....	66	Radio.....	6
Fault log.....	11	Interlock device.....	34
Fieldbus.....	32		
Filter.....	14	J	
Fuses		J8 interior view.....	7
Fuse.....	51	J9 Interior view.....	8
Overcurrent protection.....	18		
Pre-start check list.....	36	L	
Specifications.....	65	LCP	
Troubleshooting.....	57	Display.....	10
		Indicator lights.....	11
G		Menu.....	12
Galvanic isolation.....	63	Troubleshooting.....	56
Gases.....	14	Leakage current.....	4, 22
Ground		Lifting.....	13, 16
Check list.....	36	Load share	
Floating delta.....	26	Warning.....	4, 51
Grounded delta.....	26	Local control panel (LCP).....	10
Grounding.....	24		
Isolated main.....	26	M	
Warning.....	52	Main menu.....	12
Ground wire.....	22	Mains	
		Supply specifications.....	61
H		Maintenance.....	14, 44
Hand on.....	11, 45	Manual	
Heat sink		Version number.....	3
Cleaning.....	14	MCT 10.....	38
Overtemperature trip point.....	59	Menu	
Warning.....	52, 53	Descriptions of.....	12
Heater		Keys.....	11
Usage.....	14	Motor	
High voltage.....	50, 51	Cable.....	18, 24
High voltage warning.....	4	Connection.....	24
Humidity.....	14	Data.....	57
		Output specifications.....	61
I		Overheating.....	49
Indicator lights.....	47	Power.....	22
Input		Rotation.....	39
Power.....	22	Thermistor.....	43
Voltage.....	37	Troubleshooting.....	56, 57
Input specifications.....	62	Unintended motor rotation.....	5
Installation		Warning.....	48, 49, 50
Check list.....	36	Wiring schematic.....	21
Electrical.....	18	Mounting.....	15, 16, 17
EMC-compliant.....	20		
Initialization.....	40	N	
Qualified personnel.....	4	Nameplate.....	13
Quick setup.....	38	Navigation keys.....	11, 37
Start up.....	39		
Tools needed.....	13		
Installation.....	15, 16, 17		

O

Open loop
 Wiring for speed control..... 41

Optional equipment..... 34, 37

Output
 Specifications..... 63

Overcurrent protection..... 18

Overvoltage..... 58

P

Parameters..... 12, 40

PELV..... 63

Periodic forming..... 13

Phase loss..... 48

Pigtails..... 18

Potential equalization..... 22

Potentiometer..... 33

Power
 Connection..... 18
 Losses..... 59
 Ratings..... 59

Power card
 Warning..... 53

Programming..... 11

Pulse
 Input specifications..... 63

Q

Qualified personnel..... 4

Quick menu..... 11, 12

R

Ramp-down time..... 58

Ramp-up time..... 57

Recycling..... 3

Regen
 Terminals..... 28

Regional settings..... 40

Relay
 Location..... 33
 Specifications..... 64

Reset..... 11, 47, 53

RFI..... 26

Rotor
 Warning..... 54

RS485
 Configuring..... 35
 RS485..... 32
 Wiring schematic..... 21

S

Safety instructions..... 18

Serial communication
 Descriptions and default settings..... 32

Service..... 44

Set-up..... 11

Shielding
 Clamps..... 18
 Twisted ends..... 18

Shipping dimension..... 6

Short circuit..... 50

Sleep mode..... 46

Software version number..... 3

Specifications electrical..... 59

Start/stop..... 42

Status message definitions..... 45

Storage..... 13

Supply voltage..... 51

Switches
 A53 and A54..... 62
 A53/A54..... 35
 Bus termination..... 35
 Disconnect..... 65

T

Temperature..... 14

Terminal dimensions
 J8..... 28
 J9..... 30

Terminal torque rating..... 66

Terminals
 Analog input/output..... 33
 Control locations..... 32
 Digital input/output..... 33
 Relays..... 33
 Serial communication..... 32
 Terminal 37..... 34

Thermistor
 Cable routing..... 32
 Terminal location..... 33
 Wiring configurations..... 43

Tools..... 13

Torque
 Characteristic..... 61
 Limit..... 49, 57

Transducer..... 33

Trip
 Points for 380–480 V drives..... 59

Troubleshooting	
Fuses.....	57
LCP.....	56
Mains.....	57
Motor.....	56, 57
Warnings and alarms.....	48
U	
Unintended start.....	4, 44
USB	
Specifications.....	65
V	
Voltage	
Imbalance.....	48
Input.....	35
W	
Warnings	
List of.....	11, 48
Types of.....	47
Weight.....	6
Windmilling.....	5
Wire size.....	24
Wiring configurations	
External alarm reset.....	43
Open loop.....	41
Start/stop.....	42
Thermistor.....	43
Wiring control terminals.....	34
Wiring schematic	
Drive.....	21
Wiring schematic.....	21



.....
Danfoss can accept no responsibility for possible errors in catalogues, brochures and other printed material. Danfoss reserves the right to alter its products without notice. This also applies to products already on order provided that such alterations can be made without subsequential changes being necessary in specifications already agreed. All trademarks in this material are property of the respective companies. Danfoss and the Danfoss logotype are trademarks of Danfoss A/S. All rights reserved.
.....

Danfoss A/S
Ulsnaes 1
DK-6300 Graasten
vlt-drives.danfoss.com

