



Operating Guide

VLT[®] Midi Drive FC 280



Contents

1 Introduction	4
1.1 Purpose of the Manual	4
1.2 Additional Resources	4
1.3 Document and Software Version	4
1.4 Product Overview	4
1.5 Approvals and Certifications	6
1.6 Disposal	6
2 Safety	7
2.1 Safety Symbols	7
2.2 Qualified Personnel	7
2.3 Safety Precautions	7
3 Mechanical Installation	9
3.1 Unpacking	9
3.2 Installation Environment	10
3.3 Mounting	10
4 Electrical Installation	13
4.1 Safety Instructions	13
4.2 EMC-compliant Installation	13
4.3 Grounding	13
4.4 Wiring Schematic	15
4.5 Access	17
4.6 Motor Connection	17
4.7 AC Mains Connection	19
4.8 Control Wiring	19
4.8.1 Control Terminal Types	19
4.8.2 Wiring to Control Terminals	20
4.8.3 Enabling Motor Operation (Terminal 27)	20
4.8.4 Mechanical Brake Control	21
4.8.5 USB Data Communication	22
4.9 Installation Checklist	23
5 Commissioning	24
5.1 Safety Instructions	24
5.2 Applying Power	24
5.3 Local Control Panel Operation	24
5.3.1 Numeric Local Control Panel (NLCP)	24
5.3.2 The Right-key Function on NLCP	26

5.3.3 Quick Menu on NLCP	26
5.3.4 Main Menu on NLCP	28
5.3.5 Graphic Local Control Panel (GLCP)	30
5.3.6 Parameter Settings	31
5.3.7 Changing Parameter Settings with GLCP	31
5.3.8 Uploading/Downloading Data to/from the LCP	31
5.3.9 Restoring Default Settings with LCP	32
5.4 Basic Programming	32
5.4.1 Asynchronous Motor Set-up	32
5.4.2 PM Motor Set-up in VVC ⁺	32
5.4.3 Automatic Motor Adaptation (AMA)	33
5.5 Checking Motor Rotation	34
5.6 Checking Encoder Rotation	34
5.7 Local-control Test	34
5.8 System Start-up	35
5.9 Memory Module	35
5.9.1 Synchronizing Frequency Converter Data to a New Memory Module (Create Drive Backup)	35
5.9.2 Copying Data to Another Frequency Converter	36
5.9.3 Copying Data to Multiple Frequency Converters	36
5.9.4 Transferring the Firmware Information	36
5.9.5 Backing Up Parameter Changes to Memory Module	36
5.9.6 Erasing Data	37
5.9.7 Transfer Performance and Indications	37
5.9.8 Activating the PROFIBUS Converter	37
6 Safe Torque Off (STO)	39
6.1 Safety Precautions for STO	40
6.2 Safe Torque Off Installation	40
6.3 STO Commissioning	41
6.3.1 Activation of Safe Torque Off	41
6.3.2 Deactivation of Safe Torque Off	41
6.3.3 STO Commissioning Test	41
6.3.4 Test for STO Applications in Manual Restart Mode	42
6.3.5 Test for STO Applications in Automatic Restart Mode	42
6.4 Maintenance and Service for STO	42
6.5 STO Technical Data	43
7 Application Examples	44
7.1 Introduction	44
7.2 Application Examples	44

7.2.1 AMA	44
7.2.2 Speed	44
7.2.3 Start/Stop	45
7.2.4 External Alarm Reset	46
7.2.5 Motor Thermistor	46
7.2.6 SLC	46
8 Maintenance, Diagnostics, and Troubleshooting	47
8.1 Maintenance and Service	47
8.2 Warning and Alarm Types	47
8.3 Warning and Alarm Display	47
8.4 List of Warnings and Alarms	49
8.4.1 Warning and Alarm Code List	49
8.5 Troubleshooting	53
9 Specifications	55
9.1 Electrical Data	55
9.2 Mains Supply	57
9.3 Motor Output and Motor Data	57
9.4 Ambient Conditions	58
9.5 Cable Specifications	58
9.6 Control Input/Output and Control Data	59
9.7 Connection Tightening Torques	62
9.8 Fuses and Circuit Breakers	62
9.9 Enclosure Sizes, Power Ratings, and Dimensions	65
10 Appendix	68
10.1 Symbols, Abbreviations, and Conventions	68
10.2 Parameter Menu Structure	68
Index	79

1 Introduction

1.1 Purpose of the Manual

This operating guide provides information for safe installation and commissioning of the VLT® Midi Drive FC 280 frequency converter.

The operating guide is intended for use by qualified personnel.

To use the frequency converter safely and professionally, read and follow the operating guide. Pay particular attention to the safety instructions and general warnings. Always keep this operating guide with the frequency converter.

VLT® is a registered trademark.

1.2 Additional Resources

Resources available to understand advanced frequency converter functions, programming, and maintenance:

- *VLT® Midi Drive FC 280 Design Guide*, provides detailed information about the design and applications of the frequency converter.
- *VLT® Midi Drive FC 280 Programming Guide*, provides information on how to program and includes complete parameter descriptions.

Supplementary publications and manuals are available from Danfoss. See drives.danfoss.com/knowledge-center/technical-documentation/ for listings.

1.3 Document and Software Version

This manual is regularly reviewed and updated. All suggestions for improvement are welcome. *Table 1.1* shows the document version and the corresponding software version.

Edition	Remarks	Software version
MG07A5	Software update and memory module support.	1.5

Table 1.1 Document and Software Version

1.4 Product Overview

1.4.1 Intended Use

The frequency converter is an electronic motor controller intended for:

- Regulation of motor speed in response to system feedback or to remote commands from external controllers. A power drive system consists of the frequency converter, the motor, and equipment driven by the motor.
- System and motor status surveillance.

The frequency converter can also be used for motor overload protection.

Depending on configuration, the frequency converter can be used in standalone applications or form part of a larger appliance or installation.

The frequency converter is allowed for use in residential, industrial, and commercial environments in accordance with local laws and standards.

NOTICE

In a residential environment, this product can cause radio interference, in which case supplementary mitigation measures may be required.

Foreseeable misuse

Do not use the frequency converter in applications which are non-compliant with specified operating conditions and environments. Ensure compliance with the conditions specified in *chapter 9 Specifications*.

1.4.2 Block Diagram of the Frequency Converter

Illustration 1.1 is a block diagram of the internal components of the frequency converter.

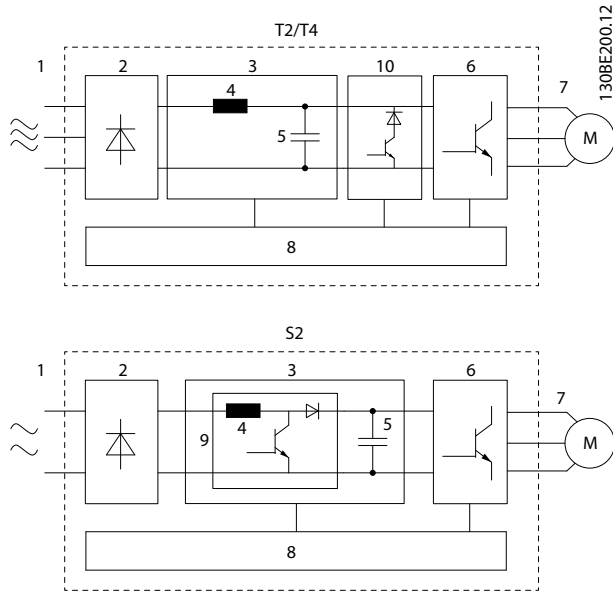

Area	Component	Functions
7	Output to motor	<ul style="list-style-type: none"> Regulated 3-phase output power to the motor.
8	Control circuitry	<ul style="list-style-type: none"> Input power, internal processing, output, and motor current are monitored to provide efficient operation and control. User interface and external commands are monitored and performed. Status output and control can be provided.
9	PFC	<ul style="list-style-type: none"> Power factor correction changes the waveform of current which is drawn by the frequency converter to improve the power factor.
10	Brake chopper	<ul style="list-style-type: none"> Brake chopper is used in the DC intermediate circuit to control DC voltage when the load feeds energy back.

Area	Component	Functions
1	Mains input	<ul style="list-style-type: none"> AC mains supply to the frequency converter.
2	Rectifier	<ul style="list-style-type: none"> The rectifier bridge converts the AC input to DC current to supply inverter power.
3	DC bus	<ul style="list-style-type: none"> Intermediate DC-bus circuit handles the DC current.
4	DC reactor	<ul style="list-style-type: none"> Filters the intermediate DC circuit current. Provides mains transient protection. Reduces the root mean square (RMS) current. Raises the power factor reflected back to the line. Reduces harmonics on the AC input.
5	Capacitor bank	<ul style="list-style-type: none"> Stores the DC power. Provides ride-through protection for short power losses.
6	Inverter	<ul style="list-style-type: none"> Converts the DC into a controlled PWM AC waveform for a controlled variable output to the motor.

Illustration 1.1 Example of Block Diagram for a Frequency Converter

1.4.3 Enclosure Sizes and Power Ratings

For enclosure sizes and power ratings of the frequency converters, refer to *chapter 9.9 Enclosure Sizes, Power Ratings, and Dimensions*.

1.4.4 Safe Torque Off (STO)

The VLT® Midi Drive FC 280 frequency converter supports Safe Torque Off (STO). See *chapter 6 Safe Torque Off (STO)* for details about the installation, commissioning, maintenance, and technical data of STO.

1.5 Approvals and Certifications

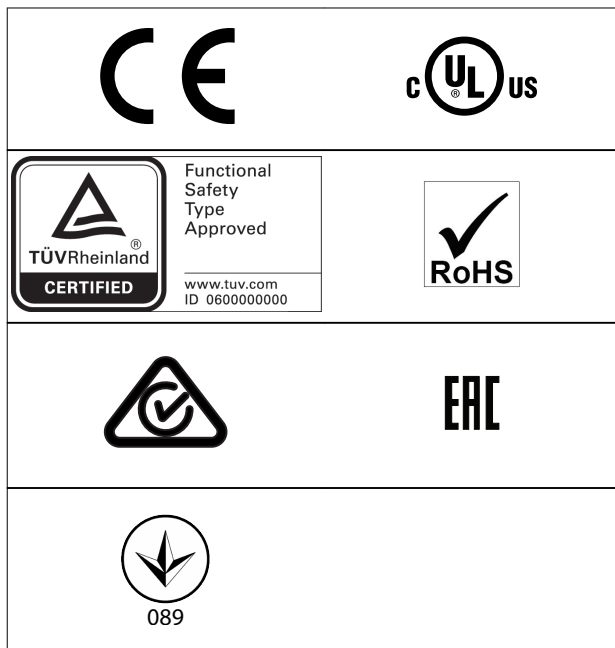

For compliance with the European Agreement concerning International Carriage of Dangerous Goods by Inland Waterways (ADN), refer to the *chapter ADN-compliant Installation* in the *VLT® Midi Drive FC 280 Design Guide*.

The frequency converter complies with UL 508C thermal memory retention requirements. For more information, refer to the *chapter Motor Thermal Protection* in the *VLT® Midi Drive FC 280 Design Guide*.

Applied standards and compliance for STO

Using STO on terminals 37 and 38 requires fulfillment of all provisions for safety including relevant laws, regulations, and guidelines. The integrated STO function complies with the following standards:

- IEC/EN 61508:2010, SIL2
- IEC/EN 61800-5-2:2007, SIL2
- IEC/EN 62061:2015, SILCL of SIL2
- EN ISO 13849-1:2015, Category 3 PL d

1.6 Disposal

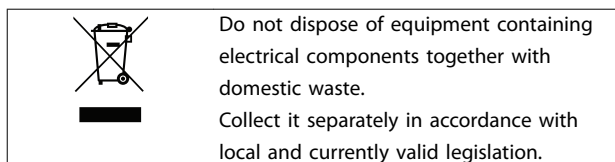

2 Safety

2.1 Safety Symbols

The following symbols are used in this document:

⚠ WARNING

Indicates a potentially hazardous situation that could result in death or serious injury.

⚠ CAUTION

Indicates a potentially hazardous situation that could result in minor or moderate injury. It can also be used to alert against unsafe practices.

NOTICE

Indicates important information, including situations that can result in damage to equipment or property.

2.2 Qualified Personnel

Correct and reliable transport, storage, installation, operation, and maintenance are required for the trouble-free and safe operation of the frequency converter. Only qualified personnel are allowed to install or operate this equipment.

Qualified personnel are defined as trained staff, who are authorized to install, commission, and maintain equipment, systems, and circuits in accordance with pertinent laws and regulations. Also, the personnel must be familiar with the instructions and safety measures described in this guide.

2.3 Safety Precautions

⚠ WARNING

HIGH VOLTAGE

Frequency converters contain high voltage when connected to AC mains input, DC supply, or load sharing. Failure to perform installation, start-up, and maintenance by qualified personnel can result in death or serious injury.

- Only qualified personnel must perform installation, start-up, and maintenance.
- Before performing any service or repair work, use an appropriate voltage measuring device to make sure that there is no remaining voltage on the frequency converter.

⚠ WARNING

UNINTENDED START

When the frequency converter is connected to AC mains, DC supply, or load sharing, the motor may start at any time. Unintended start during programming, service, or repair work can result in death, serious injury, or property damage. The motor can start with an external switch, a fieldbus command, an input reference signal from the LCP, via remote operation using MCT 10 Set-up Software, or after a cleared fault condition.

To prevent unintended motor start:

- Disconnect the frequency converter from the mains.
- Press [Off/Reset] on the LCP before programming parameters.
- Completely wire and assemble the frequency converter, motor, and any driven equipment before connecting the frequency converter to AC mains, DC supply, or load sharing.

⚠ WARNING

DISCHARGE TIME

The frequency converter contains DC-link capacitors, which can remain charged even when the frequency converter is not powered. High voltage can be present even when the warning LED indicator lights are off. Failure to wait the specified time after power has been removed before performing service or repair work can result in death or serious injury.

- Stop the motor.
- Disconnect AC mains and remote DC-link supplies, including battery back-ups, UPS, and DC-link connections to other frequency converters.
- Disconnect or lock PM motor.
- Wait for the capacitors to discharge fully. The minimum waiting time is specified in *Table 2.1*.
- Before performing any service or repair work, use an appropriate voltage measuring device to make sure that the capacitors are fully discharged.

Voltage [V]	Power range [kW (hp)]	Minimum waiting time (minutes)
200–240	0.37–3.7 (0.5–5)	4
380–480	0.37–7.5 (0.5–10)	4
	11–22 (15–30)	15

Table 2.1 Discharge Time

⚠ WARNING**LEAKAGE CURRENT HAZARD**

Leakage currents exceed 3.5 mA. Failure to ground the drive properly can result in death or serious injury.

- Ensure the correct grounding of the equipment by a certified electrical installer.

⚠ WARNING**EQUIPMENT HAZARD**

Contact with rotating shafts and electrical equipment can result in death or serious injury.

- Ensure that only trained and qualified personnel perform installation, start-up, and maintenance.
- Ensure that electrical work conforms to national and local electrical codes.
- Follow the procedures in this guide.

⚠ CAUTION**INTERNAL FAILURE HAZARD**

An internal failure in the frequency converter can result in serious injury when the frequency converter is not properly closed.

- Ensure that all safety covers are in place and securely fastened before applying power.

3 Mechanical Installation

3.1 Unpacking

3.1.1 Items Supplied

Items supplied may vary according to product configuration.

- Make sure that the items supplied and the information on the nameplate correspond to the order confirmation.
- Check the packaging and the frequency converter visually for damage caused by inappropriate handling during shipment. File any claim for damage with the carrier. Retain damaged parts for clarification.



1	Product logo
2	Product name
3	Disposal
4	CE mark
5	Serial number
6	TÜV logo
7	UkrSEPRO logo
8	Barcode
9	Country of origin
10	Reference to enclosure type
11	EAC logo
12	RCM logo
13	UL reference
14	Warning specifications
15	UL logo
16	IP rating
17	Output voltage, frequency, and current (at low/high voltages)
18	Input voltage, frequency, and current (at low/high voltages)
19	Power rating
20	Ordering number
21	Type code

Illustration 3.1 Product Nameplate (Example)

NOTICE

Do not remove the nameplate from the frequency converter (loss of warranty).

For more information of the type code, refer to the *chapter Type Code* in the *VLT® Midi Drive FC 280 Design Guide*.

3.1.2 Storage

Ensure that requirements for storage are fulfilled. Refer to *chapter 9.4 Ambient Conditions* for further details.

3.2 Installation Environment

NOTICE

In environments with airborne liquids, particles, or corrosive gases, ensure that the IP/Type rating of the equipment matches the installation environment. Failure to meet requirements for ambient conditions can reduce lifetime of the frequency converter. Ensure that requirements for air humidity, temperature, and altitude are met.

Vibration and shock

The frequency converter complies with requirements for units mounted on the walls and floors of production premises, and in panels bolted to walls or floors.

For detailed ambient conditions specifications, refer to *chapter 9.4 Ambient Conditions*.

3.3 Mounting

NOTICE

Improper mounting can result in overheating and reduced performance.

Cooling

- Ensure 100 mm (3.9 in) of top and bottom clearance for air cooling.

Lifting

- To determine a safe lifting method, check the weight of the unit, see *chapter 9.9 Enclosure Sizes, Power Ratings, and Dimensions*.
- Ensure that the lifting device is suitable for the task.
- If necessary, plan for a hoist, crane, or forklift with the appropriate rating to move the unit.
- For lifting, use hoist rings on the unit, when provided.

Mounting

To adapt the mounting holes of VLT® Midi Drive FC 280, contact the local Danfoss supplier to order a separate backplate.

To mount the frequency converter:

1. Ensure that the mounting location is strong enough to support the unit weight. The frequency converter allows side-by-side installation.
2. Place the unit as close to the motor as possible. Keep the motor cables as short as possible.
3. Mount the unit vertically to a solid flat surface or to the optional backplate to provide cooling airflow.
4. When provided, use the slotted mounting holes on the unit for wall mounting.

NOTICE

For dimensions of mounting holes, see *chapter 9.9 Enclosure Sizes, Power Ratings, and Dimensions*.

3.3.1 Side-by-side Installation

Side-by-side installation

All VLT® Midi Drive FC 280 units can be installed side by side in vertical or horizontal position. The units do not require extra ventilation on the side.

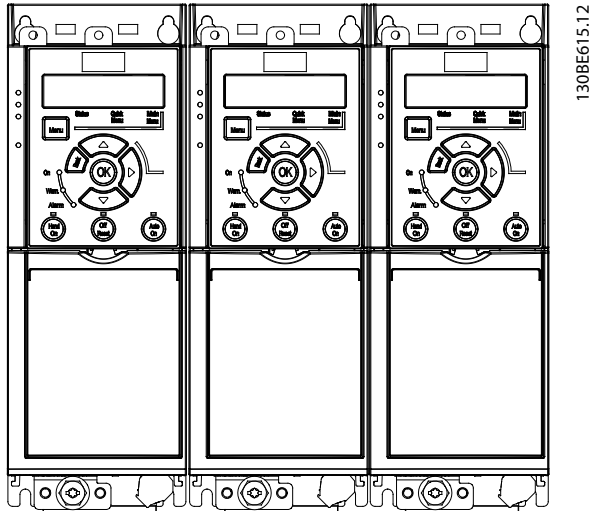

Illustration 3.2 Side-by-side Installation

NOTICE

RISK OF OVERHEATING

If IP21 conversion kit is used, mounting the units side by side could lead to overheating and damage to the unit.

- At least 30 mm (1.2 in) is required between the top cover edges of IP21 conversion kit.

3.3.2 Horizontal Mounting

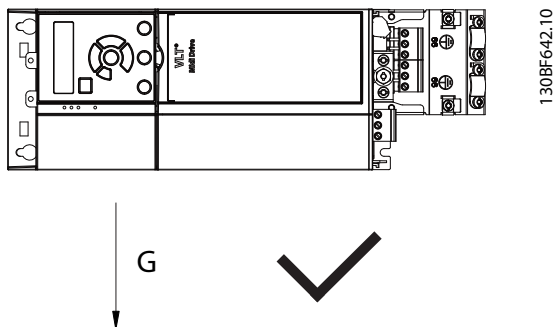

Illustration 3.3 Right Way of Horizontal Mounting (Left Side Downwards)

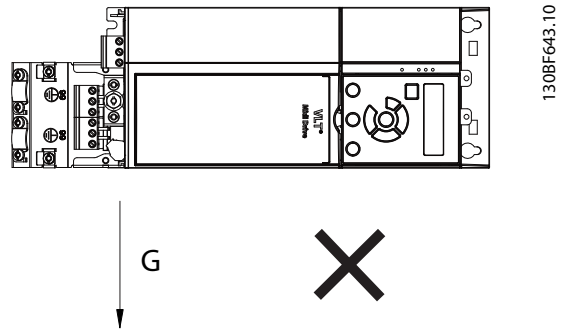

Illustration 3.4 Wrong Way of Horizontal Mounting (Right Side Downwards)

3.3.3 Bus Decoupling Kit

The bus decoupling kit ensures mechanical fixation and electrical shielding of cables for the following control cassette variants:

- Control cassette with PROFIBUS.
- Control cassette with PROFINET.
- Control cassette with CANopen.
- Control cassette with Ethernet.
- Control cassette with POWERLINK.

Each bus decoupling kit contains 1 horizontal decoupling plate and 1 vertical decoupling plate. Mounting the vertical decoupling plate is optional. The vertical decoupling plate provides better mechanical support for PROFINET, Ethernet, and POWERLINK connectors and cables.

3.3.4 Mounting

To mount the bus decoupling kit:

1. Place the horizontal decoupling plate on the control cassette mounted on the frequency converter and fasten the plate using 2 screws as shown in *Illustration 3.5*. Tightening torque is 0.7–1.0 Nm (6.2–8.9 in-lb).
2. Optional: Mount the vertical decoupling plate as follows:
 - 2a Remove the 2 mechanical springs and 2 metal clamps from the horizontal plate.
 - 2b Mount the mechanical springs and metal clamps on the vertical plate.
 - 2c Fasten the plate with 2 screws as shown in *Illustration 3.6*. Tightening torque is 0.7–1.0 Nm (6.2–8.9 in-lb).

NOTICE

If the IP21 top cover is used, do not mount the vertical decoupling plate, because its height affects the proper installation of the IP21 top cover.

3

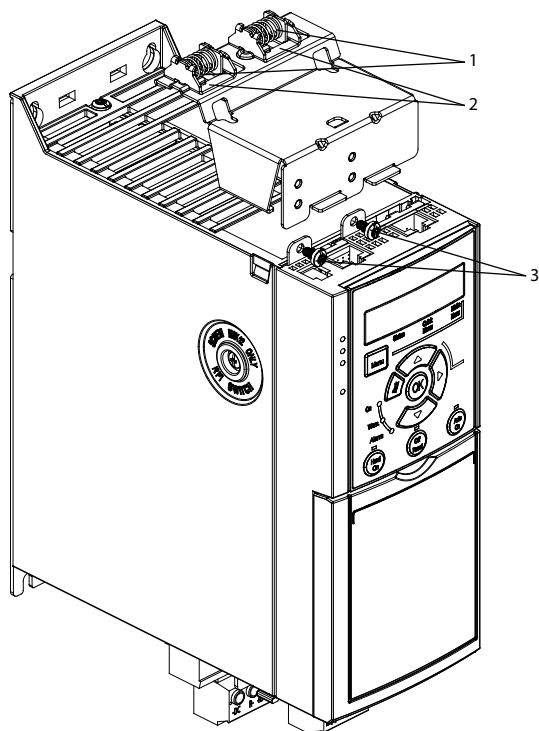

1	Mechanical springs
2	Metal clamps
3	Screws

Illustration 3.5 Fasten the Horizontal Decoupling Plate with Screws

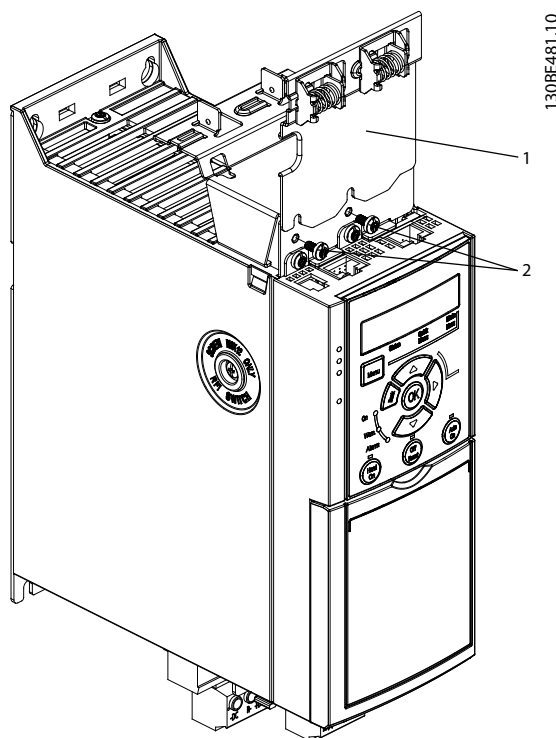

1	Vertical decoupling plate
2	Screws

Illustration 3.6 Fasten the Vertical Decoupling Plate with Screws

Both *Illustration 3.5* and *Illustration 3.6* show Ethernet-based connectors (RJ45). The actual connector type depends on the selected fieldbus variant of the frequency converter.

3. Ensure proper wiring of the fieldbus cables (PROFIBUS/CANopen) or push the cable connectors (RJ45 for PROFINET/POWERLINK/Ethernet/IP) into the sockets in the control cassette.
4.
 - 4a Place the PROFIBUS/CANopen cables between the spring-loaded metal clamps to establish mechanical fixation and electrical contact between the shielded sections of the cables and the clamps.
 - 4b Place the PROFINET/POWERLINK/Ethernet/IP cables between the spring-loaded metal clamps to establish mechanical fixation between the cables and the clamps.

4 Electrical Installation

4.1 Safety Instructions

See *chapter 2 Safety* for general safety instructions.

⚠ WARNING

INDUCED VOLTAGE

Induced voltage from output motor cables of different frequency converters that run together can charge equipment capacitors even with the equipment turned off and locked out. Failure to run output motor cables separately or use shielded cables could result in death or serious injury.

- Run output motor cables separately.
- Use shielded cables.
- Lock out all the frequency converters simultaneously.

⚠ WARNING

SHOCK HAZARD

The frequency converter can cause a DC current in the PE conductor and hence result in death or serious injury.

- When a residual current-operated protective device (RCD) is used for protection against electrical shock, only an RCD of Type B is allowed on the supply side.

Failure to follow the recommendation means that the RCD cannot provide the intended protection.

Overcurrent protection

- Extra protective equipment such as short-circuit protection or motor thermal protection between frequency converter and motor is required for applications with multiple motors.
- Input fusing is required to provide protection against short circuit and overcurrent. If fuses are not factory-supplied, the installer must provide them. See maximum fuse ratings in *chapter 9.8 Fuses and Circuit Breakers*.

Wire type and ratings

- All wiring must comply with local and national regulations regarding cross-section and ambient temperature requirements.
- Power connection wire recommendation: Minimum 75 °C (167 °F) rated copper wire.

See *chapter 9.5 Cable Specifications* for recommended wire sizes and types.

4.2 EMC-compliant Installation

To obtain an EMC-compliant installation, follow the instructions provided in *chapter 4.3 Grounding*, *chapter 4.4 Wiring Schematic*, *chapter 4.6 Motor Connection*, and *chapter 4.8 Control Wiring*.

4.3 Grounding

⚠ WARNING

LEAKAGE CURRENT HAZARD

Leakage currents exceed 3.5 mA. Failure to ground the frequency converter properly could result in death or serious injury.

- Ensure the correct grounding of the equipment by a certified electrical installer.

For electrical safety

- Ground the frequency converter in accordance with applicable standards and directives.
- Use a dedicated ground wire for input power, motor power, and control wiring.
- Do not ground 1 frequency converter to another in a daisy-chain fashion (see *Illustration 4.1*).
- Keep the ground wire connections as short as possible.
- Follow motor manufacturer wiring requirements.
- Minimum cable cross-section for the ground wires: 10 mm² (7 AWG).
- Separately terminate individual ground wires, both complying with the dimension requirements.

4

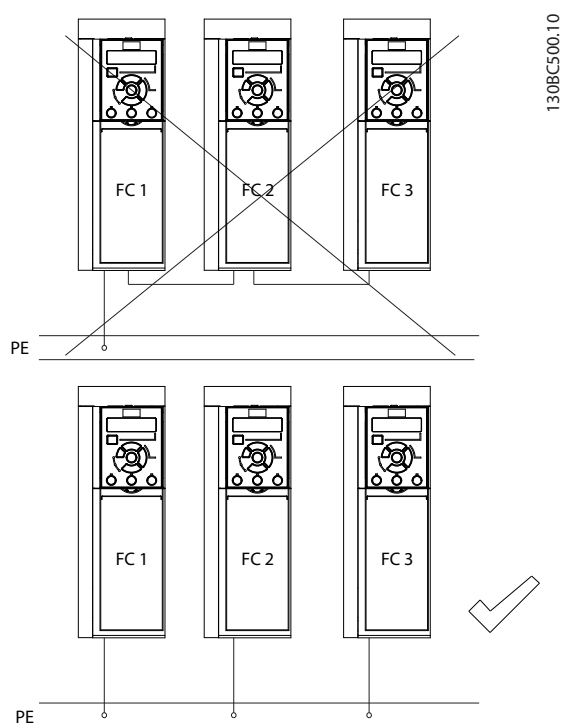

Illustration 4.1 Grounding Principle

For EMC-compliant installation

- Establish electrical contact between the cable shield and the frequency converter enclosure by using metal cable glands or by using the clamps provided on the equipment (see *chapter 4.6 Motor Connection*).
- Use high-strand wire to reduce burst transient.
- Do not use pigtails.

NOTICE**POTENTIAL EQUALIZATION**

Risk of burst transient when the ground potential between the frequency converter and the control system is different. Install equalizing cables between the system components. Recommended cable cross-section: 16 mm² (6 AWG).

4.4 Wiring Schematic

This section describes how to wire the frequency converter.

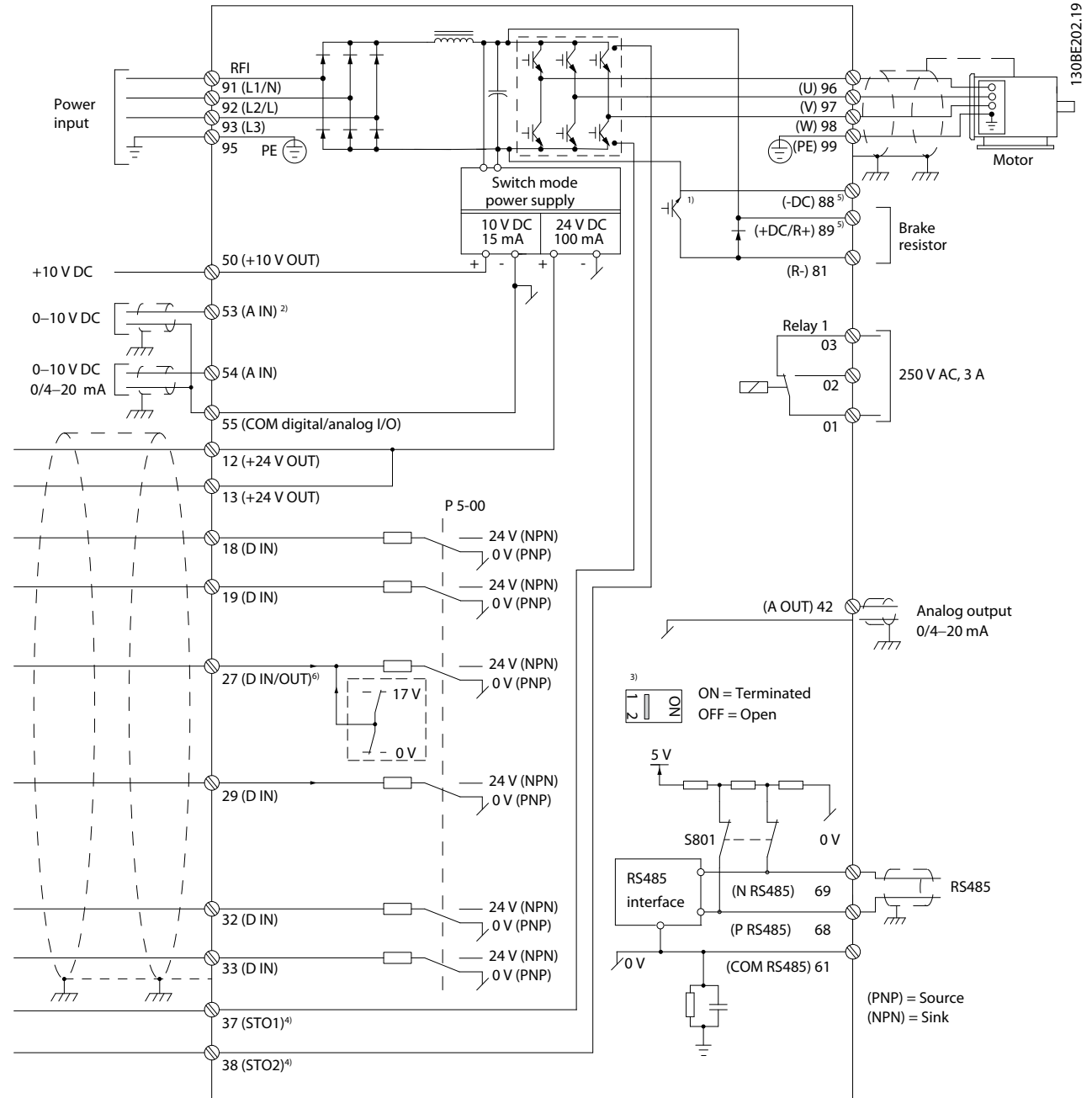
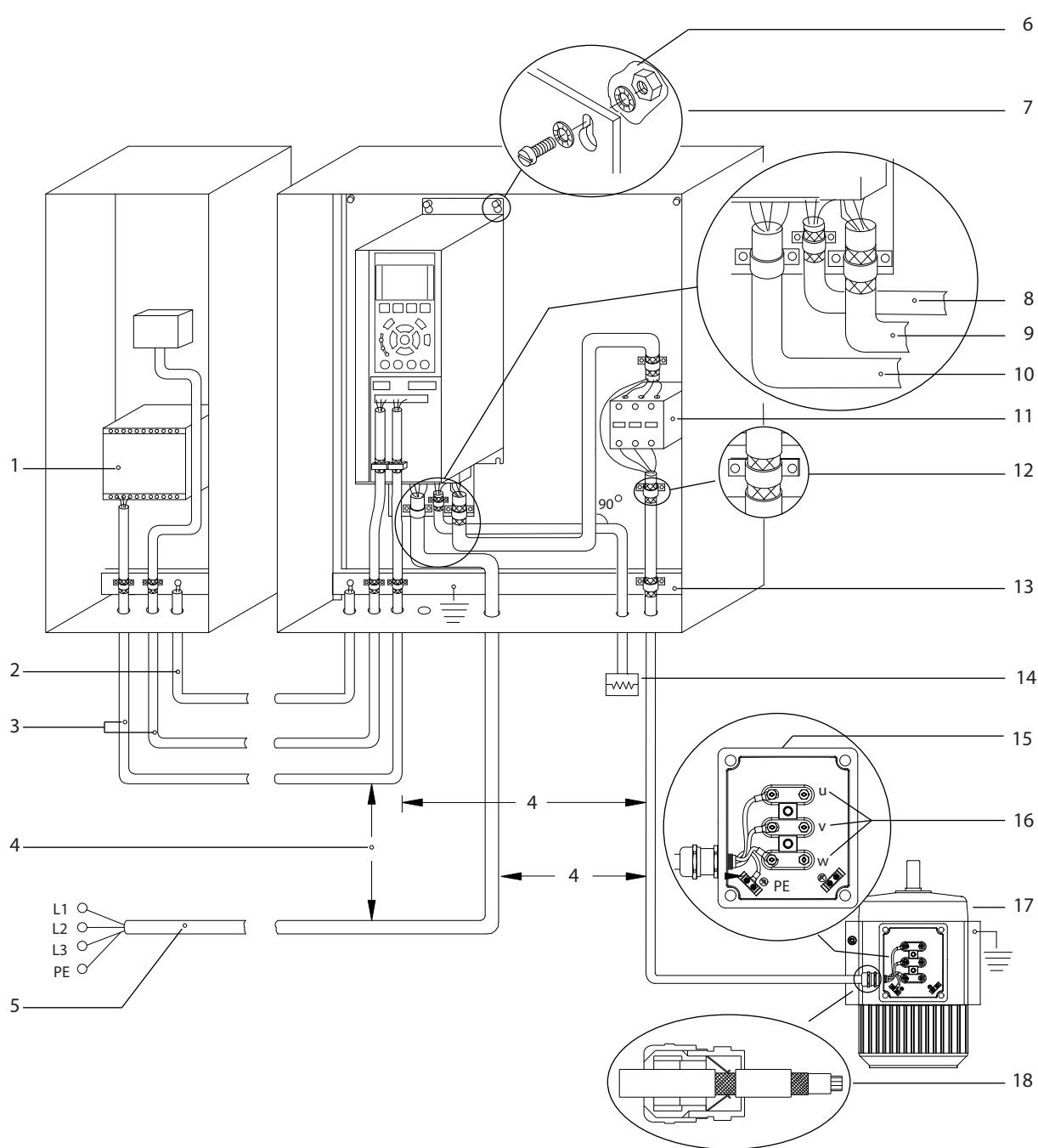

Illustration 4.2 Basic Wiring Schematic Drawing

A=Analog, D=Digital

- 1) Built-in brake chopper is only available on 3-phase units.
- 2) Terminal 53 can also be used as digital input.
- 3) Switch S801 (bus terminal) can be used to enable termination on the RS485 port (terminals 68 and 69).
- 4) Refer to chapter 6 Safe Torque Off (STO) for the correct STO wiring.
- 5) The S2 (single-phase 200–240 V) frequency converter does not support load sharing application.
- 6) The maximum voltage is 17 V for terminal 27 as analog output.

4



e30bf228.11

1	PLC	10	Mains cable (unshielded)
2	Minimum 16 mm ² (6 AWG) equalizing cable	11	Output contactor, and more.
3	Control cables	12	Cable insulation stripped
4	Minimum 200 mm (7.87 in) between control cables, motor cables, and mains cables.	13	Common ground busbar. Follow local and national requirements for cabinet grounding.
5	Mains supply	14	Brake resistor
6	Bare (unpainted) surface	15	Metal box
7	Star washers	16	Connection to motor
8	Brake cable (shielded)	17	Motor
9	Motor cable (shielded)	18	EMC cable gland

Illustration 4.3 Typical Electrical Connection

4.5 Access

- Remove the cover plate with a screwdriver. See *Illustration 4.4*.

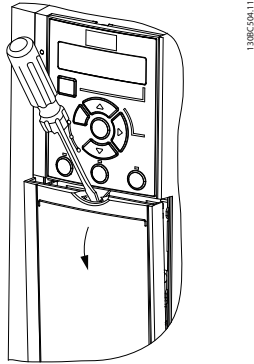

Illustration 4.4 Control Wiring Access

4.6 Motor Connection

WARNING

INDUCED VOLTAGE

Induced voltage from output motor cables that run together can charge equipment capacitors, even when the equipment is turned off and locked out. Failure to run output motor cables separately or use shielded cables could result in death or serious injury.

- Run output motor cables separately.
- Use shielded cables.
- Comply with local and national electrical codes for cable sizes. For maximum cable sizes, see *chapter 9.1 Electrical Data*.
- Follow motor manufacturer wiring requirements.
- Motor wiring knockouts or access panels are provided at the base of IP21/Type 1 units.
- Do not wire a starting or pole-changing device (for example, Dahlander motor or slip ring induction motor) between the frequency converter and the motor.

Procedure

- Strip a section of the outer cable insulation.
- Position the stripped cable under the cable clamp to establish mechanical fixation and electrical contact between the cable shield and ground.
- Connect the ground cable to the nearest grounding terminal in accordance with the grounding instructions provided in *chapter 4.3 Grounding*. See *Illustration 4.5*.
- Connect the 3-phase motor wiring to terminals 96 (U), 97 (V), and 98 (W), as shown in *Illustration 4.5*.
- Tighten the terminals in accordance with the information provided in *chapter 9.7 Connection Tightening Torques*.

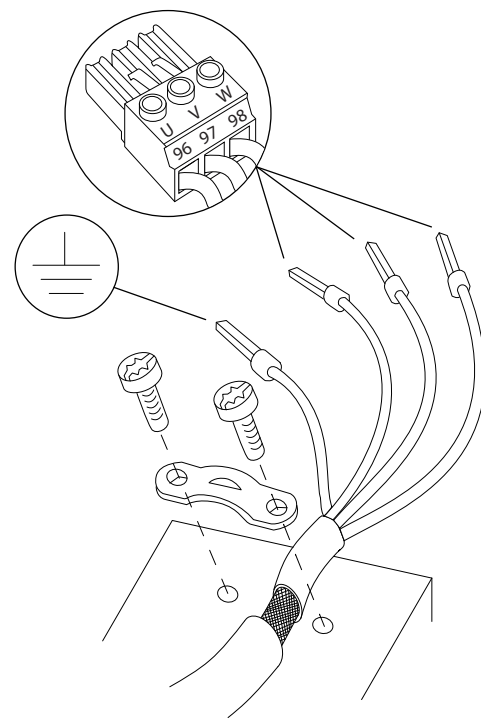
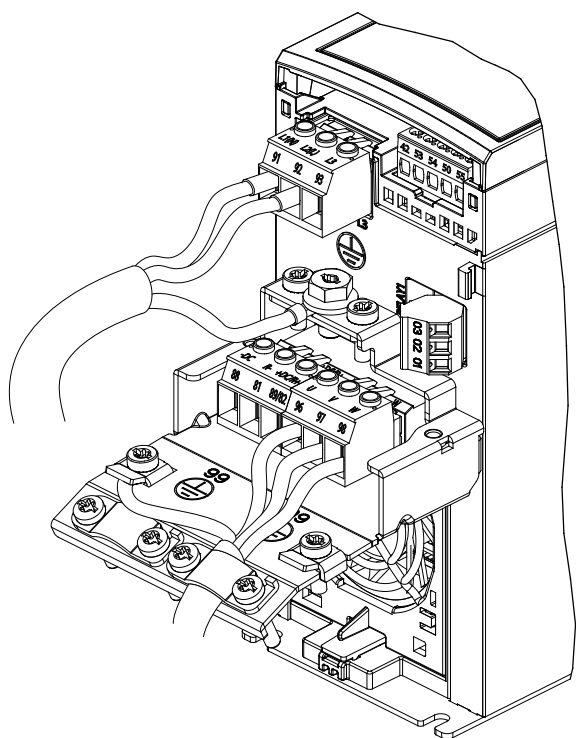

Illustration 4.5 Motor Connection

The mains, motor, and grounding connection for single-phase and 3-phase frequency converters are shown in *Illustration 4.6*, *Illustration 4.7*, and *Illustration 4.8* respectively. Actual configurations vary with unit types and optional equipment.

4



130BE232.11

Illustration 4.6 Mains, Motor, and Grounding Connection for Single-phase Units

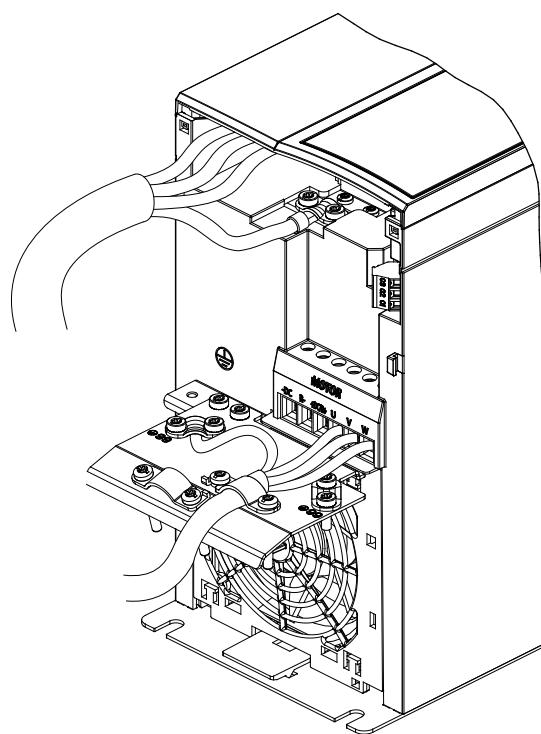

130BE804.10

Illustration 4.8 Mains, Motor, and Grounding Connection for 3-phase Units (K4, K5)

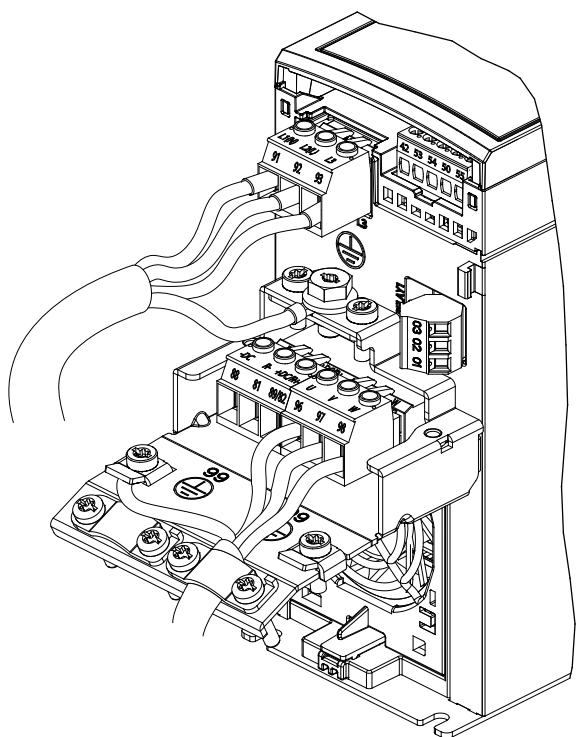

130BE231.11

Illustration 4.7 Mains, Motor, and Grounding Connection for 3-phase Units (K1, K2, K3)

4.7 AC Mains Connection

- Size the wiring based on the input current of the frequency converter. For maximum wire sizes, see *chapter 9.1 Electrical Data*.
- Comply with local and national electrical codes for cable sizes.

Procedure

1. Connect the AC input power cables to terminals N and L for single-phase units (see *Illustration 4.6*), or to terminals L1, L2, and L3 for 3-phase units (see *Illustration 4.7*).
2. Depending on the configuration of the equipment, connect the input power to the mains input terminals or the input disconnect.
3. Ground the cable in accordance with the grounding instructions in *chapter 4.3 Grounding*.
4. When supplied from an isolated mains source (IT mains or floating delta) or TT/TN-S mains with a grounded leg (grounded delta), ensure that the RFI filter screw is removed. Removing the RFI screw prevents damage to the DC link and reduces ground capacity currents in accordance with IEC 61800-3 (see *Illustration 9.2*, the RFI screw is on the side of the frequency converter).

4.8 Control Wiring

4.8.1 Control Terminal Types

Illustration 4.9 shows the removable frequency converter connectors. Terminal functions and default settings are summarized in *Table 4.1* and *Table 4.2*.

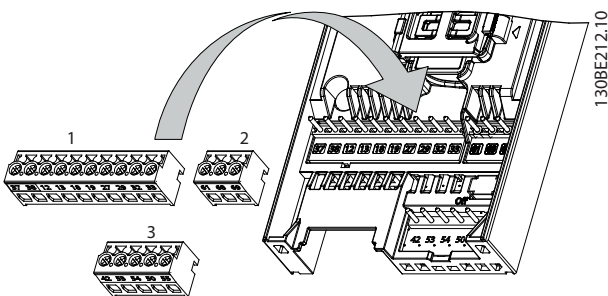

Illustration 4.9 Control Terminal Locations

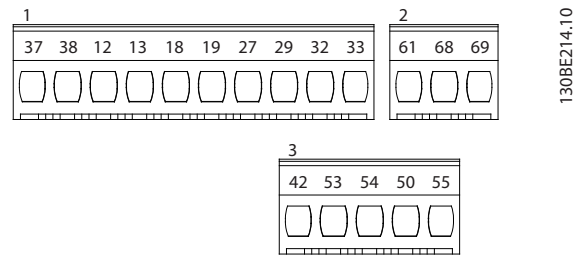

Illustration 4.10 Terminal Numbers

See *chapter 9.6 Control Input/Output and Control Data* for terminal ratings details.

Terminal	Parameter	Default setting	Description
Digital I/O, pulse I/O, encoder			
12, 13	-	+24 V DC	24 V DC supply voltage. Maximum output current is 100 mA for all 24 V loads.
18	Parameter 5-10 Terminal 18 Digital Input	[8] Start	Digital inputs.
19	Parameter 5-11 Terminal 19 Digital Input	[10] Reversing	
27	Parameter 5-01 Terminal 27 Mode Parameter 5-12 Terminal 27 Digital Input Parameter 5-30 Terminal 27 Digital Output	DI [2] Coast inverse DO [0] No operation	Selectable for either digital input, digital output, or pulse output. The default setting is digital input.
29	Parameter 5-13 Terminal 29 Digital Input	[14] Jog	Digital input.
32	Parameter 5-14 Terminal 32 Digital Input	[0] No operation	Digital input, 24 V encoder. Terminal 33 can be used for pulse input.
33	Parameter 5-15 Terminal 33 Digital Input	[0] No operation	
37, 38	-	STO	Functional safety inputs.
Analog inputs/outputs			

Terminal	Parameter	Default setting	Description
42	Parameter 6-91 Terminal 42 Analog Output	[0] No operation	Programmable analog output. The analog signal is 0–20 mA or 4–20 mA at a maximum of 500 Ω. Can also be configured as digital outputs.
50	–	+10 V DC	10 V DC analog supply voltage. 15 mA maximum commonly used for potentiometer or thermistor.
53	Parameter group 6-1* Analog input 53	–	Analog input. Only voltage mode is supported. It can also be used as digital input.
54	Parameter group 6-2* Analog input 54	–	Analog input. Selectable between voltage or current mode.
55	–	–	Common for digital and analog inputs.

Table 4.1 Terminal Descriptions - Digital Inputs/Outputs, Analog Inputs/Outputs

Terminal	Parameter	Default setting	Description
Serial communication			
61	–	–	Integrated RC filter for cable shield. ONLY for connecting the shield when experiencing EMC problems.
68 (+)	Parameter group 8-3* FC port settings	–	RS485 interface. A control card switch is provided for termination resistance.
69 (-)	Parameter group 8-3* FC port settings	–	
Relays			

Terminal	Parameter	Default setting	Description
01, 02, 03	Parameter 5-40 Function Relay	[1] Control Ready	Form C relay output. These relays are in various locations depending on the frequency converter configuration and size. Usable for AC or DC voltage and resistive or inductive loads.

Table 4.2 Terminal Descriptions - Serial Communication

4.8.2 Wiring to Control Terminals

Control terminal connectors can be unplugged from the frequency converter for ease of installation, as shown in *Illustration 4.9*.

For details about STO wiring, refer to *chapter 6 Safe Torque Off (STO)*.

NOTICE

Keep control cables as short as possible and separate them from high-power cables to minimize interference.

1. Loosen the screws for the terminals.
2. Insert sleeved control cables into the slots.
3. Fasten the screws for the terminals.
4. Ensure that the contact is firmly established and not loose. Loose control wiring can be the source of equipment faults or less than optimal operation.

See *chapter 9.5 Cable Specifications* for control terminal cable sizes and *chapter 7 Application Examples* for typical control cable connections.

4.8.3 Enabling Motor Operation (Terminal 27)

A jumper wire is required between terminal 12 (or 13) and terminal 27 for the frequency converter to operate when using factory default programming values.

- Digital input terminal 27 is designed to receive 24 V DC external interlock command.
- When no interlock device is used, wire a jumper between control terminal 12 (recommended) or 13 to terminal 27. The jumper provides an internal 24 V signal on terminal 27.

- Only for GLCP: When the status line at the bottom of the LCP reads *AUTO REMOTE COAST*, it indicates that the unit is ready to operate but is missing an input signal on terminal 27.

NOTICE

UNABLE TO START

The frequency converter cannot operate without a signal on terminal 27, unless terminal 27 is reprogrammed.

4.8.4 Mechanical Brake Control

In hoisting/lowering applications, it is necessary to control an electro-mechanical brake.

- Control the brake using any relay output or digital output (terminal 27).
- Keep the output closed (voltage-free) as long as the frequency converter is unable to keep the motor at standstill, for example due to the load being too heavy.

- Select [32] *Mechanical brake control* in parameter group 5-4* *Relays* for applications with an electro-mechanical brake.
- The brake is released when the motor current exceeds the preset value in parameter 2-20 *Release Brake Current*.
- The brake is engaged when the output frequency is less than the frequency set in parameter 2-22 *Activate Brake Speed [Hz]*, and only if the frequency converter carries out a stop command.

If the frequency converter is in 1 of the following situations, the mechanical brake immediately closes.

- In alarm mode.
- In an overvoltage situation.
- STO is activated.
- Coast command is given.

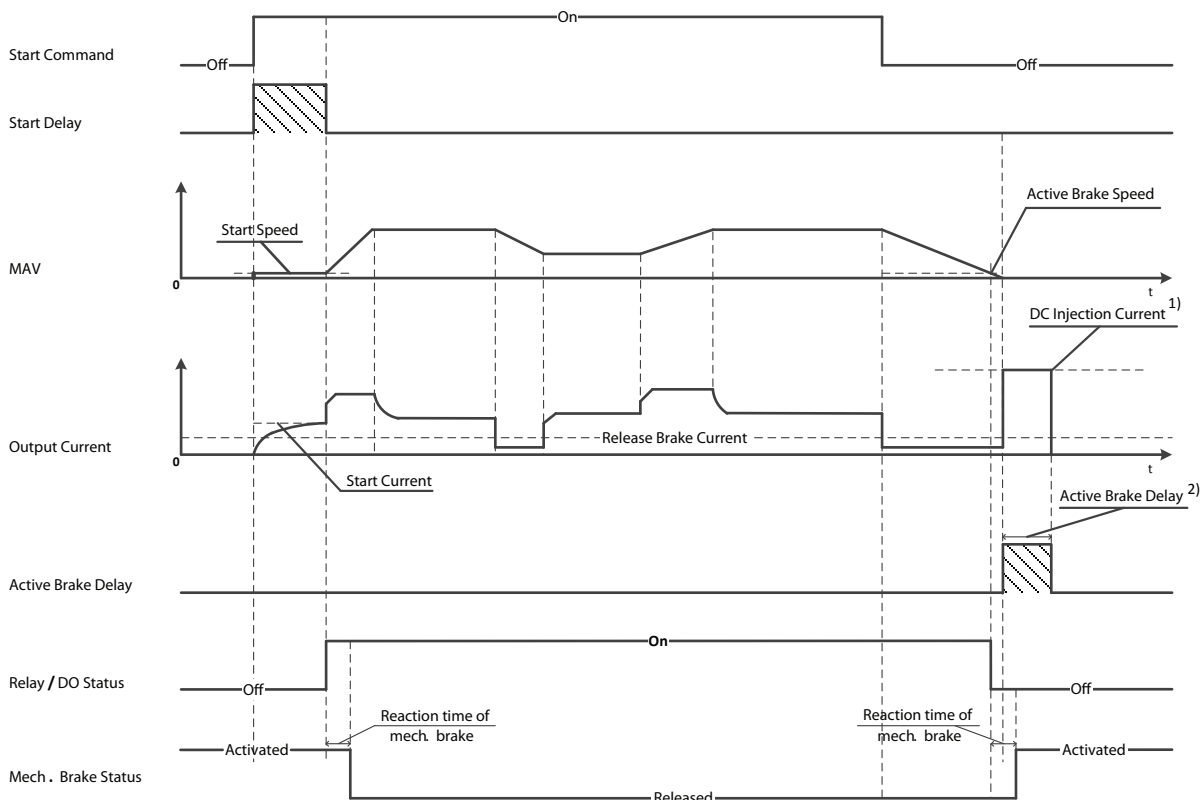

130BF687.10

Note: 1) DC injection current during "Active Brake Delay" after MAV reduced to "0". Only support in some products.
 2) Only support in some products.

Illustration 4.11 Mechanical Brake

The frequency converter is not a safety device. It is the responsibility of the system designer to integrate safety devices according to relevant national crane/lift regulations.

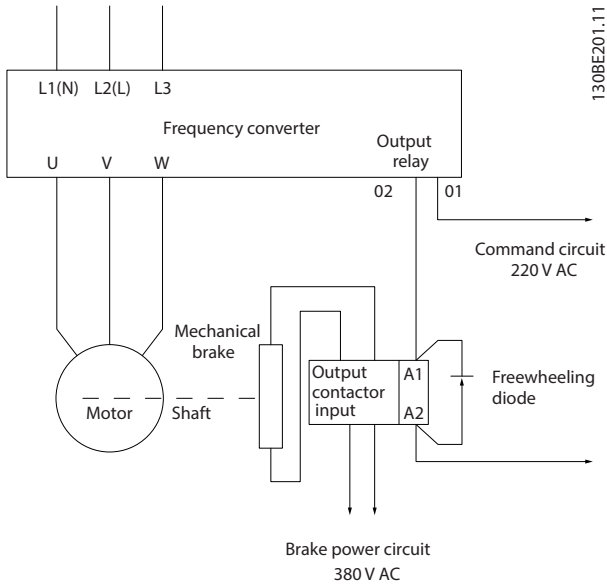

Illustration 4.12 Connecting the Mechanical Brake to the Frequency Converter

4.8.5 USB Data Communication

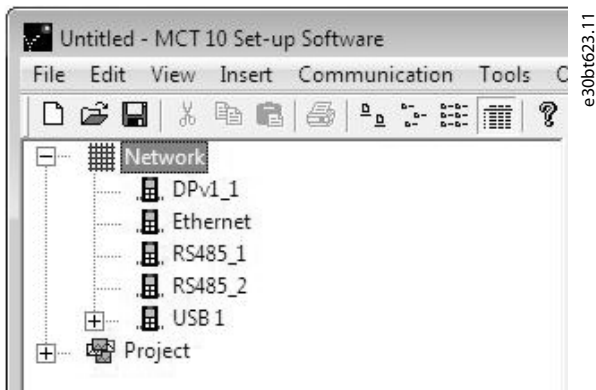

Illustration 4.13 Network Bus List

When the USB cable is disconnected, the frequency converter connected via the USB port is removed from the Network bus list.

NOTICE

A USB bus has no address-setting capacity and no bus name to configure. If connecting more than 1 frequency converter through USB, the bus name is auto-incremented in the MCT 10 Set-up Software Network bus list. Connecting more than 1 frequency converter through a USB cable often causes computers installed with Windows XP to throw an exception and crash. Therefore it is advised only to connect 1 frequency converter via USB to the PC.

4.8.6 RS485 Serial Communication

Connect RS485 serial communication wiring to terminals (+)68 and (-)69.

- Shielded serial communication cable is recommended.
- See chapter 4.3 Grounding for proper grounding.

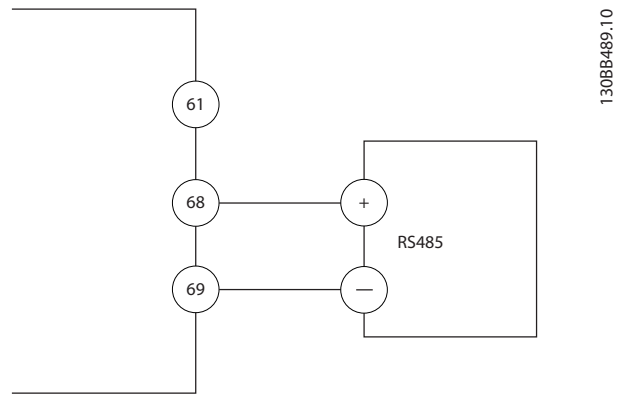

Illustration 4.14 Serial Communication Wiring Diagram

For basic serial communication set-up, select the following:

1. Protocol type in *parameter 8-30 Protocol*.
2. Frequency converter address in *parameter 8-31 Address*.
3. Baud rate in *parameter 8-32 Baud Rate*.

Two communication protocols are internal to the frequency converter. Follow motor manufacturer wiring requirements.

- Danfoss FC.
- Modbus RTU.

Functions can be programmed remotely using the protocol software and RS485 connection, or in *parameter group 8-3** Communications and Options*.

Selecting a specific communication protocol changes various default parameter settings to match the speci-

cations of the protocol and makes extra protocol-specific parameters available.

4.9 Installation Checklist

Before completing installation of the unit, inspect the entire installation as detailed in *Table 4.3*. Check and mark the items when completed.

Inspect for	Description	<input checked="" type="checkbox"/>
Auxiliary equipment	<ul style="list-style-type: none"> Look for auxiliary equipment, switches, disconnects, or input fuses/circuit breakers, which may reside on the input power side of the frequency converter or output side to the motor. Ensure that they are ready for full-speed operation. Check the function and installation of any sensors used for feedback to the frequency converter. Remove any power factor correction capacitors on the motor(s). Adjust any power factor correction capacitors on the mains side and ensure that they are dampened. 	
Cable routing	<ul style="list-style-type: none"> Ensure that the motor wiring and control wiring are separated, shielded, or in 3 separate metallic conduits for high frequency interference isolation. 	
Control wiring	<ul style="list-style-type: none"> Check for broken or damaged wires and loose connections. Check that the control wiring is isolated from power and motor wiring for noise immunity. Check the voltage source of the signals, if necessary. <p>The use of shielded cable or twisted pair is recommended. Ensure that the shield is terminated correctly.</p>	
Cooling clearance	<ul style="list-style-type: none"> Ensure that the top and bottom clearance is adequate to ensure proper airflow for cooling, see <i>chapter 3.3 Mounting</i>. 	
Ambient conditions	<ul style="list-style-type: none"> Check that requirements for ambient conditions are met. 	
Fusing and circuit breakers	<ul style="list-style-type: none"> Check for proper fusing or circuit breakers. Check that all fuses are inserted firmly and are in operational condition and that all circuit breakers are in the open position. 	
Grounding	<ul style="list-style-type: none"> Check for sufficient ground connections and ensure that they are tight and free of oxidation. Do not ground to conduit, or mount the back panel to a metal surface. 	
Input and output power wiring	<ul style="list-style-type: none"> Check for loose connections. Check that the motor and mains cables are in separate conduit or separated shielded cables. 	
Panel interior	<ul style="list-style-type: none"> Inspect that the unit interior is free of dirt, metal chips, moisture, and corrosion. Check that the unit is mounted on an unpainted, metal surface. 	
Switches	<ul style="list-style-type: none"> Ensure that all switch and disconnect settings are in the proper positions. 	
Vibration	<ul style="list-style-type: none"> Check that the unit is mounted solidly, or that shock mounts are used, as necessary. Check for an unusual amount of vibration. 	

Table 4.3 Installation Check List

CAUTION

POTENTIAL HAZARD IN THE EVENT OF INTERNAL FAILURE

Risk of personal injury if the frequency converter is not properly closed.

- Before applying power, ensure that all safety covers are in place and securely fastened.

5 Commissioning

5.1 Safety Instructions

See *chapter 2 Safety* for general safety instructions.

WARNING

HIGH VOLTAGE

Frequency converters contain high voltage when connected to AC mains input power. Failure to perform installation, start-up, and maintenance by qualified personnel could result in death or serious injury.

- Installation, start-up, and maintenance must be performed by qualified personnel only.

Before applying power:

1. Close the cover properly.
2. Check that all cable glands are firmly tightened.
3. Ensure that input power to the unit is off and locked out. Do not rely on the frequency converter disconnect switches for input power isolation.
4. Verify that there is no voltage on input terminals L1 (91), L2 (92), and L3 (93), phase-to-phase, and phase-to-ground.
5. Verify that there is no voltage on output terminals 96 (U), 97 (V), and 98 (W), phase-to-phase, and phase-to-ground.
6. Confirm continuity of the motor by measuring Ω values on U–V (96–97), V–W (97–98), and W–U (98–96).
7. Check for proper grounding of the frequency converter and the motor.
8. Inspect the frequency converter for loose connections on the terminals.
9. Confirm that the supply voltage matches the voltage of the frequency converter and the motor.

5.2 Applying Power

Apply power to the frequency converter using the following steps:

1. Confirm that the input voltage is balanced within 3%. If not, correct the input voltage imbalance before proceeding. Repeat this procedure after the voltage correction.
2. Ensure that any optional equipment wiring matches the installation application.
3. Ensure that all operator devices are in the OFF position. Panel doors must be closed and covers securely fastened.
4. Apply power to the unit. Do not start the frequency converter now. For units with a disconnect switch, turn it to the ON position to apply power to the frequency converter.

5.3 Local Control Panel Operation

The frequency converter supports numerical local control panel (NLCP), graphic local control panel (GLCP), and blind cover. This section describes the operations with NLCP and GLCP.

NOTICE

The frequency converter can also be programmed from the MCT 10 Set-up Software on PC via RS485 communication port or USB port. This software can be ordered using ordering number 130B1000 or downloaded from the Danfoss website: drives.danfoss.com/downloads/pc-tools/#/.

5.3.1 Numeric Local Control Panel (NLCP)

The numerical local control panel (NLCP) is divided into 4 functional sections.

- A. Numeric display.
- B. Menu key.
- C. Navigation keys and indicator lights (LEDs).
- D. Operation keys and indicator lights (LEDs).

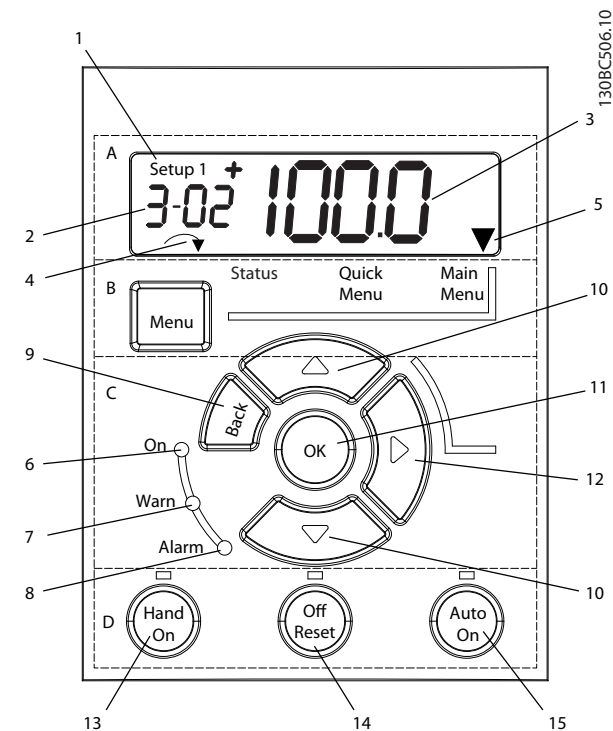

Illustration 5.1 View of the NLCP

A. Numeric display

The LCD display is backlit with 1 numeric line. All data is shown in the NLCP.

1	The set-up number shows the active set-up and the edit set-up. If the same set-up acts as both active and edit set-up, only that set-up number is shown (factory setting). When active and edit set-up differ, both numbers are shown in the display (for example set-up 12). The number flashing indicates the edit set-up.
2	Parameter number.
3	Parameter value.
4	Motor direction is shown at the bottom left of the display. A small arrow indicates the direction.
5	The triangle indicates whether the LCP is in Status, Quick Menu, or Main Menu.

Table 5.1 Legend to Illustration 5.1, Section A



Illustration 5.2 Display Information

B. Menu key

To select between Status, Quick Menu, or Main Menu, press [Menu].

C. Indicator lights (LEDs) and navigation keys

	Indicator	Light	Function
6	On	Green	ON turns on when the frequency converter receives power from the mains voltage, a DC bus terminal, or a 24 V external supply.
7	Warn	Yellow	When warning conditions are met, the yellow WARN LED turns on, and text appears in the display area identifying the problem.
8	Alarm	Red	A fault condition causes the red alarm LED to flash and an alarm text is shown.

Table 5.2 Legend to Illustration 5.1, Indicator Lights (LEDs)

	Key	Function
9	[Back]	For moving to the previous step or layer in the navigation structure.
10	[▲] [▼]	For switching between parameter groups, parameters, and within parameters, or increasing/decreasing parameter values. Arrows can also be used for setting local reference.
11	[OK]	Press to access parameter groups or to enable a selection.
12	[▶]	Press to move from left to right within the parameter value to change each digit individually.

Table 5.3 Legend to Illustration 5.1, Navigation Keys

D. Operation keys and indicator lights (LEDs)

	Key	Function
13	Hand On	Starts the frequency converter in local control. <ul style="list-style-type: none"> An external stop signal by control input or serial communication overrides the local hand on.
14	Off/Reset	Stops the motor but does not remove power to the frequency converter or resets the frequency converter manually after a fault has been cleared. If in alarm mode, the alarm is reset if the alarm condition is removed.
15	Auto On	Puts the system in remote operational mode. <ul style="list-style-type: none"> Responds to an external start command by control terminals or serial communication.

Table 5.4 Legend to Illustration 5.1, Section D

⚠ WARNING**ELECTRICAL HAZARD**

Even after pressing the [Off/Reset] key, voltage is present at the terminals of the frequency converter. Pressing the [Off/Reset] key does not disconnect the frequency converter from mains. Touching live parts can result in death or serious injury.

- Do not touch any live parts.

5.3.2 The Right-key Function on NLCP

Press [▶] to edit any of the 4 digits on the display individually. When pressing [▶] once, the cursor moves to the first digit, and the digit starts flashing as shown in *Illustration 5.3*. Press the [▲] [▼] to change the value. Pressing [▶] does not change the value of the digits, or move the decimal point.

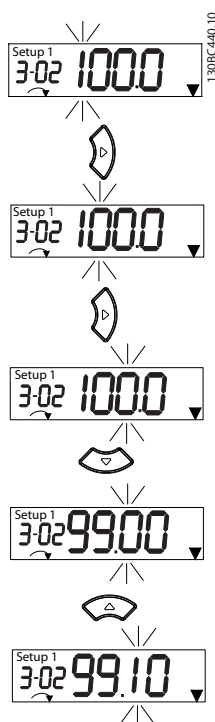

Illustration 5.3 Right-key Function

[▶] can also be used for moving between parameter groups. When in *Main Menu*, press [▶] to move to the first parameter in the next parameter group (for example, move from *parameter 0-03 Regional Settings [0] International* to *parameter 1-00 Configuration Mode [0] Open loop*).

NOTICE

During start-up, the LCP shows the message *INITIALISING*. When this message is no longer shown, the frequency converter is ready for operation. Adding or removing options can extend the duration of start-up.

5.3.3 Quick Menu on NLCP

The *Quick Menu* gives easy access to the most frequently used parameters.

1. To enter *Quick Menu*, press [Menu] until the indicator in the display is placed above *Quick Menu*.
2. Press [▲] [▼] to select either QM1 or QM2, then press [OK].
3. Press [▲] [▼] to browse through the parameters in *Quick Menu*.
4. Press [OK] to select a parameter.
5. Press [▲] [▼] to change the value of a parameter setting.
6. Press [OK] to accept the change.
7. To exit, press either [Back] twice (or 3 times if in QM2 and QM3) to enter *Status*, or press [Menu] once to enter *Main Menu*.

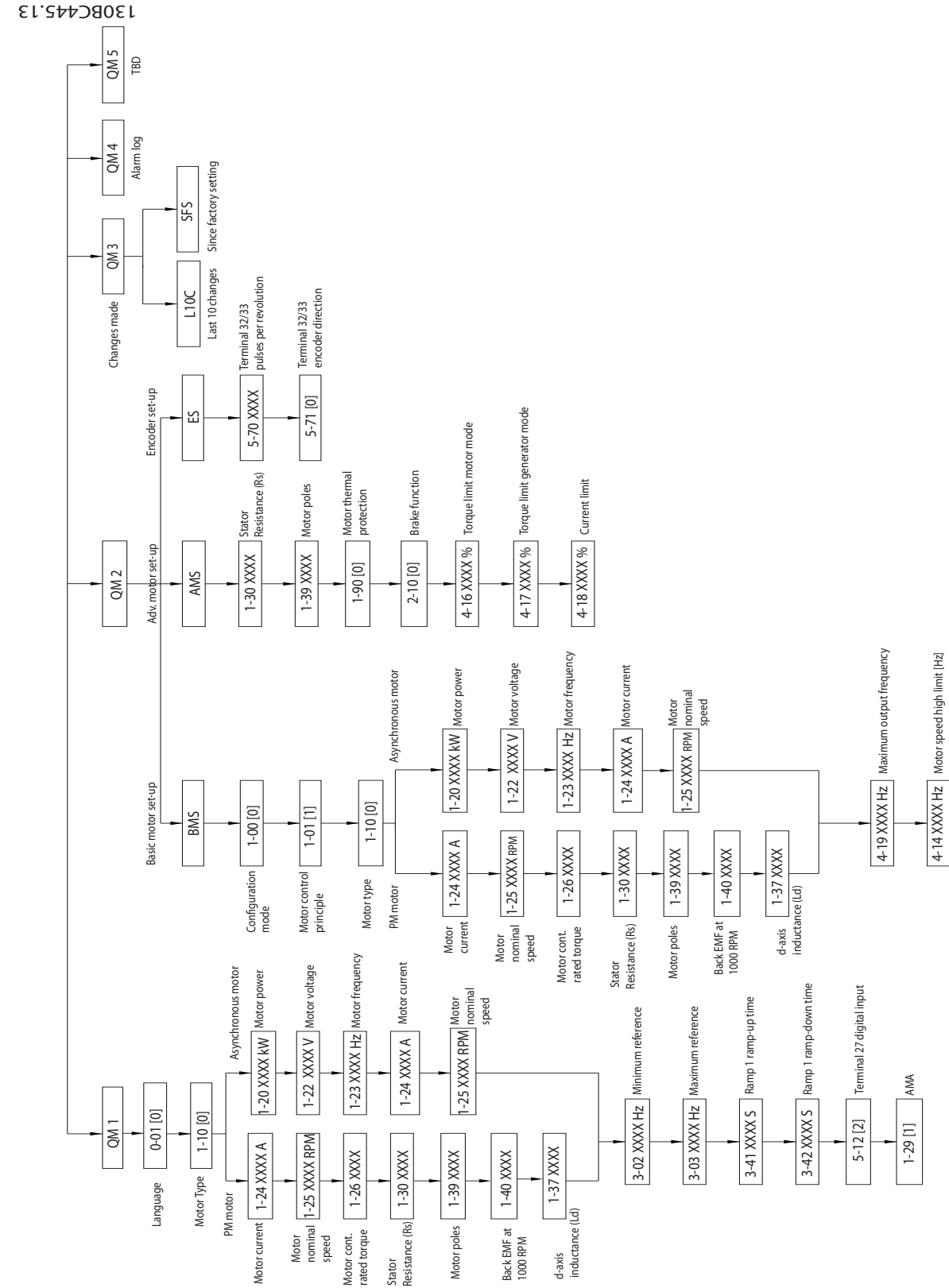

Illustration 5.4 Quick Menu Structure

5.3.4 Main Menu on NLCP

The *Main Menu* gives access to all parameters.

1. To enter *Main Menu*, press [Menu] until the indicator in the display is placed above *Main Menu*.
2. [▲] [▼]: Browse through the parameter groups.
3. Press [OK] to select a parameter group.
4. [▲] [▼]: Browse through the parameters in the specific group.
5. Press [OK] to select the parameter.
6. [▶] and [▲]/ [▼]: Set/change the parameter value.
7. Press [OK] to accept the value.
8. To exit, press either [Back] twice (or 3 times for array parameters) to enter *Main Menu*, or press [Menu] once to enter *Status*.

See *Illustration 5.5*, *Illustration 5.6*, and *Illustration 5.7* for the principles of changing the value of continuous, enumerated, and array parameters, respectively. The actions in the illustrations are described in *Table 5.5*, *Table 5.6*, and *Table 5.7*.

5

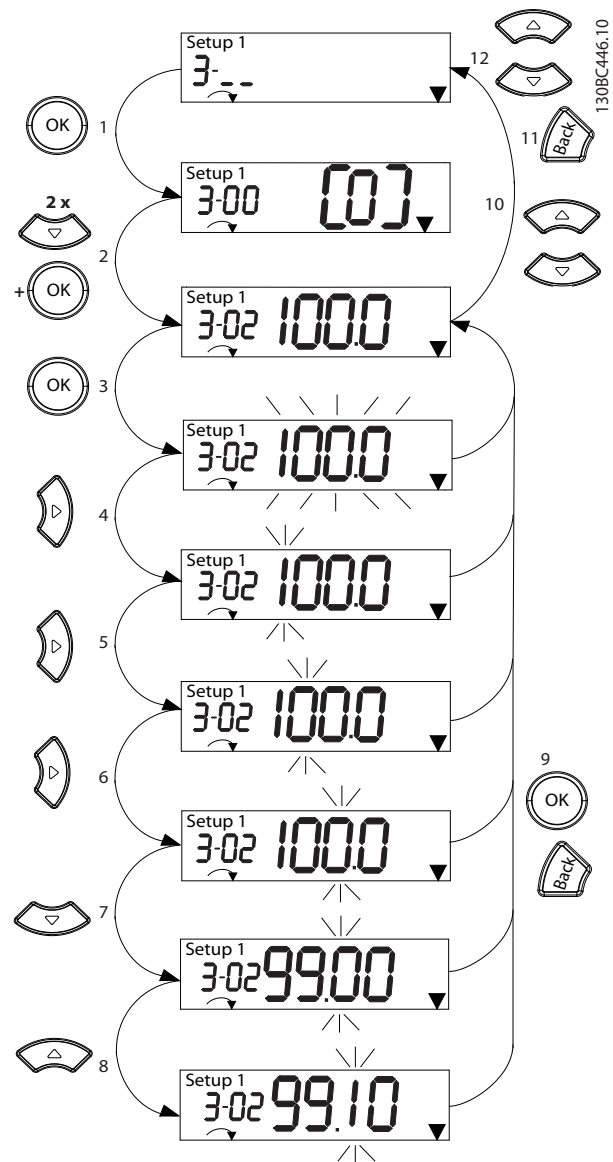

Illustration 5.5 Main Menu Interactions - Continuous Parameters

1	[OK]: The first parameter in the group is shown.
2	Press [▼] repeatedly to move down to the parameter.
3	Press [OK] to start editing.
4	[▶]: First digit flashing (can be edited).
5	[▶]: Second digit flashing (can be edited).
6	[▶]: Third digit flashing (can be edited).
7	[▼]: Decrease the parameter value, the decimal point changes automatically.
8	[▲]: Increase the parameter value.
9	[Back]: Cancel changes, return to 2. [OK]: Accept changes, return to 2.
10	[▲][▼]: Select parameter within the group.
11	[Back]: Remove the value and show the parameter group.
12	[▲][▼]: Select group.

Table 5.5 Changing Values in Continuous Parameters

For enumerated parameters, the interaction is similar, but the parameter value is shown in brackets because of the digits limitation (4 large digits) on the NLCP, and the enum can be greater than 99. When the enum value is greater than 99, the LCP can only show the first part of the bracket.

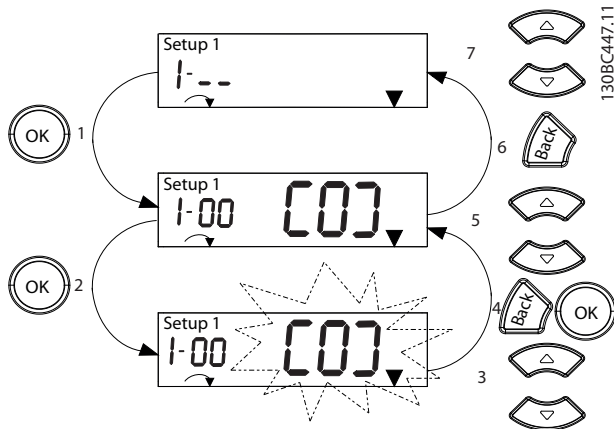

Illustration 5.6 Main Menu Interactions - Enumerated Parameters

1	[OK]: The first parameter in the group is shown.
2	Press [OK] to start editing.
3	[▲][▼]: Change parameter value (flashing).
4	Press [Back] to cancel changes or [OK] to accept changes (return to screen 2).
5	[▲][▼]: Select a parameter within the group.
6	[Back]: Remove the value and show the parameter group.
7	[▲][▼]: Select a group.

Table 5.6 Changing Values in Enumerated Parameters

Array parameters function as follows:

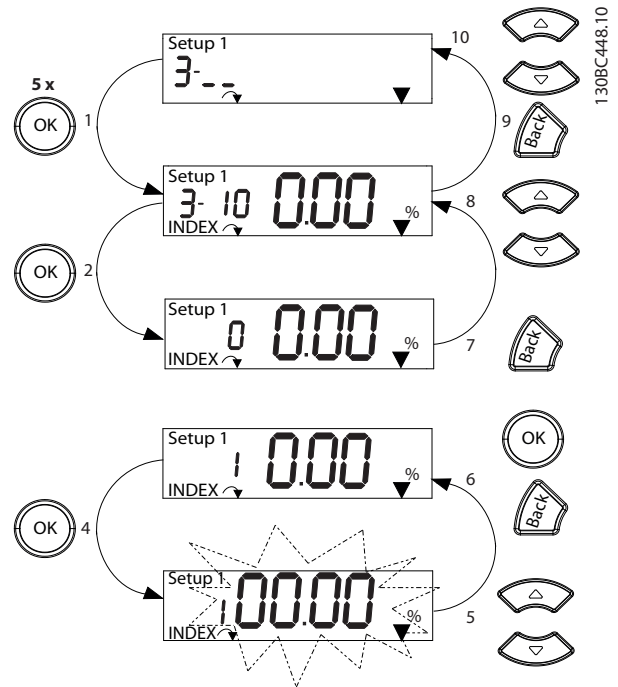

Illustration 5.7 Main Menu Interactions - Array Parameters

1	[OK]: Show parameter numbers and the value in the first index.
2	[OK]: Index can be selected.
3	[▲][▼]: Select index.
4	[OK]: Value can be edited.
5	[▲][▼]: Change parameter value (flashing).
6	[Back]: Cancel changes. [OK]: Accept changes.
7	[Back]: Cancel editing index, select a new parameter.
8	[▲][▼]: Select parameter within the group.
9	[Back]: Remove parameter index value and show the parameter group.
10	[▲][▼]: Select group.

Table 5.7 Changing Values in Array Parameters

5.3.5 Graphic Local Control Panel (GLCP)

The GLCP is divided into 4 functional groups (see *Illustration 5.8*).

- A. Display area.
- B. Display menu keys.
- C. Navigation keys and indicator lights (LEDs).
- D. Operation keys and reset.

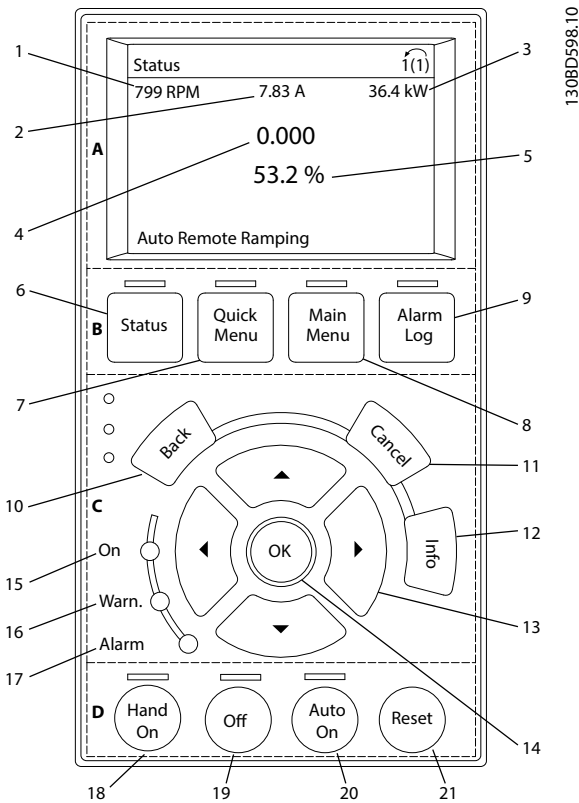

Illustration 5.8 Graphic Local Control Panel (GLCP)

A. Display area

The display area is activated when the frequency converter receives power from the mains voltage, a DC bus terminal, or a 24 V DC external supply.

The information shown on the LCP can be customized for user applications. Select options in the *Quick Menu Q3-13 Display Settings*.

Display	Parameter number	Default setting
1	0-20	[1602] Reference [%]
2	0-21	[1614] Motor Current
3	0-22	[1610] Power [kW]
4	0-23	[1613] Frequency
5	0-24	[1502] kWh Counter

Table 5.8 Legend to *Illustration 5.8*, Display Area

B. Display menu keys

Menu keys are used for menu access for parameter set-up, toggling through status display modes during normal operation, and viewing fault log data.

	Key	Function
6	Status	Shows operational information.
7	Quick Menu	Allows access to programming parameters for initial set-up instructions and many detailed application instructions.
8	Main Menu	Allows access to all programming parameters.
9	Alarm Log	Shows a list of current warnings, the last 10 alarms, and the maintenance log.

Table 5.9 Legend to *Illustration 5.8*, Display Menu Keys

C. Navigation keys and indicator lights (LEDs)

Navigation keys are used for programming functions and moving the display cursor. The navigation keys also provide speed control in local operation. There are also 3 frequency converter status indicator lights in this area.

	Key	Function
10	Back	Reverts to the previous step or list in the menu structure.
11	Cancel	Cancels the last change or command as long as the display mode has not changed.
12	Info	Press for a definition of the function being shown.
13	Navigation keys	To move between items in the menu, use the 4 navigation keys.
14	OK	Press to access parameter groups or to enable a selection.

Table 5.10 Legend to *Illustration 5.8*, Navigation Keys

	Indicator	Light	Function
15	On	Green	ON turns on when the frequency converter receives power from the mains voltage, a DC bus terminal, or a 24 V external supply.
16	Warn	Yellow	When warning conditions are met, the yellow WARN LED turns on, and text appears in the display area identifying the problem.
17	Alarm	Red	A fault condition causes the red alarm LED to flash, and an alarm text is shown.

Table 5.11 Legend to *Illustration 5.8*, Indicator Lights (LEDs)

D. Operation keys and reset

Operation keys are at the bottom of the LCP.

	Key	Function
18	Hand On	Starts the frequency converter in hand-on mode. <ul style="list-style-type: none"> An external stop signal by control input or serial communication overrides the local hand on.
19	Off	Stops the motor but does not remove power to the frequency converter.
20	Auto On	Puts the system in remote operational mode. <ul style="list-style-type: none"> Responds to an external start command by control terminals or serial communication.
21	Reset	Resets the frequency converter manually after a fault has been cleared.

Table 5.12 Legend to *Illustration 5.8*, Operation Keys and Reset**NOTICE**

To adjust the display contrast, press [Status] and the [▲]/[▼] keys.

5.3.6 Parameter Settings

Establishing the correct programming for applications often requires setting functions in several related parameters. Parameter details are provided in *chapter 10.2 Parameter Menu Structure*.

Programming data is stored internally in the frequency converter.

- For back-up, upload data into the LCP memory.
- To download data to another frequency converter, connect the LCP to that unit and download the stored settings.
- Restoring factory default settings does not change data stored in the LCP memory.

5.3.7 Changing Parameter Settings with GLCP

Access and change parameter settings from the *Quick Menu* or from the *Main Menu*. The *Quick Menu* only gives access to a limited number of parameters.

1. Press [Quick Menu] or [Main Menu] on the LCP.
2. Press [▲] [▼] to browse through the parameter groups, press [OK] to select a parameter group.
3. Press [▲] [▼] to browse through the parameters, press [OK] to select a parameter.
4. Press [▲] [▼] to change the value of a parameter setting.

5. Press [◀] [▶] to shift digit when a decimal parameter is in the editing state.
6. Press [OK] to accept the change.
7. Press either [Back] twice to enter Status, or press [Main Menu] once to enter the Main Menu.

View changes

Quick Menu Q5 - Changes Made lists all parameters changed from default settings.

- The list only shows parameters, which have been changed in the current edit set-up.
- Parameters which have been reset to default values are not listed.
- The message *Empty* indicates that no parameters have been changed.

5.3.8 Uploading/Downloading Data to/from the LCP

1. Press [Off] to stop the motor before uploading or downloading data.
2. Press [Main Menu] *parameter 0-50 LCP Copy* and press [OK].
3. Select [1] *All to LCP* to upload data to the LCP or select [2] *All from LCP* to download data from the LCP.
4. Press [OK]. A progress bar shows the uploading or downloading progress.
5. Press [Hand On] or [Auto On] to return to normal operation.

5.3.9 Restoring Default Settings with LCP

NOTICE

Risk of losing programming, motor data, localization, and monitoring records by restoration of default settings. To provide a back-up, upload data to the LCP before initialization.

Restoring the default parameter settings is done by initialization of the frequency converter. Initialization is carried out through *parameter 14-22 Operation Mode* (recommended) or manually. Initialization does not reset the settings for *parameter 1-06 Clockwise Direction* and *parameter 0-03 Regional Settings*.

- Initialization using *parameter 14-22 Operation Mode* does not reset frequency converter settings, such as operating hours, serial communication selections, fault log, alarm log, and other monitoring functions.
- Manual initialization erases all motor, programming, localization, and monitoring data and restores factory default settings.

Recommended initialization procedure, via *parameter 14-22 Operation Mode*

1. Select *parameter 14-22 Operation Mode* and press [OK].
2. Select [2] *Initialisation* and press [OK].
3. Remove power to the unit and wait until the display turns off.
4. Apply power to the unit.

Default parameter settings are restored during start-up. This may take slightly longer than normal.

5. *Alarm 80, Drive initialised to default value* is shown.
6. Press [Reset] to return to operation mode.

Manual initialization procedure

1. Remove power to the unit and wait until the display turns off.
2. Press and hold [Status], [Main Menu], and [OK] at the same time on the GLCP, or press [Menu] and [OK] at the same time on the NLCP while applying power to the unit (approximately 5 s or until a click is heard and the fan starts).

Factory default parameter settings are restored during start-up. This may take slightly longer than normal.

Manual initialization does not reset the following frequency converter information:

- *Parameter 15-00 Operating hours.*
- *Parameter 15-03 Power Up's.*
- *Parameter 15-04 Over Temp's.*

- *Parameter 15-05 Over Volt's.*

5.4 Basic Programming

5.4.1 Asynchronous Motor Set-up

Enter the following motor data in the listed order. Find the information on the motor nameplate.

1. *Parameter 1-20 Motor Power.*
2. *Parameter 1-22 Motor Voltage.*
3. *Parameter 1-23 Motor Frequency.*
4. *Parameter 1-24 Motor Current.*
5. *Parameter 1-25 Motor Nominal Speed.*

For optimum performance in VVC⁺ mode, extra motor data is required to set up the following parameters.

6. *Parameter 1-30 Stator Resistance (Rs).*
7. *Parameter 1-31 Rotor Resistance (Rr).*
8. *Parameter 1-33 Stator Leakage Reactance (X1).*
9. *Parameter 1-35 Main Reactance (Xh).*

The data is found in the motor datasheet (this data is typically not available on the motor nameplate). Run a complete AMA using *parameter 1-29 Automatic Motor Adaption (AMA) [1] Enable Complete AMA* or enter the parameters manually.

Application-specific adjustment when running VVC⁺

VVC⁺ is the most robust control mode. In most situations, it provides optimum performance without further adjustments. Run a complete AMA for best performance.

5.4.2 PM Motor Set-up in VVC⁺

Initial programming steps

1. Set *parameter 1-10 Motor Construction* to the following options to activate PM motor operation:
 - 1a [1] *PM, non salient SPM*
 - 1b [3] *PM, salient IPM*
2. Select [0] *Open Loop* in *parameter 1-00 Configuration Mode*.

NOTICE

Encoder feedback is not supported for PM motors.

Programming motor data

After selecting 1 of the PM motor options in *parameter 1-10 Motor Construction*, the PM motor-related parameters in *parameter groups 1-2* Motor Data, 1-3* Adv. Motor Data, and 1-4* Adv. Motor Data II* are active. Find the information on the motor nameplate and in the motor datasheet.

Program the following parameters in the listed order:

1. *Parameter 1-24 Motor Current.*
2. *Parameter 1-26 Motor Cont. Rated Torque.*
3. *Parameter 1-25 Motor Nominal Speed.*
4. *Parameter 1-39 Motor Poles.*
5. *Parameter 1-30 Stator Resistance (Rs).*
Enter line-to-common stator winding resistance (Rs). If only line-line data is available, divide the line-line value by 2 to achieve the line-to-common (starpoint) value.
It is also possible to measure the value with an ohmmeter, which also takes the resistance of the cable into account. Divide the measured value by 2 and enter the result.
6. *Parameter 1-37 d-axis Inductance (Ld).*
Enter line-to-common direct axis inductance of the PM motor.
If only line-to-line data is available, divide the line-line value by 2 to achieve the line-common (starpoint) value.
It is also possible to measure the value with an inductance meter, which also takes the inductance of the cable into account. Divide the measured value by 2 and enter the result.
7. *Parameter 1-40 Back EMF at 1000 RPM.*
Enter line-to-line back EMF of the PM motor at 1000 RPM mechanical speed (RMS value). Back EMF is the voltage generated by a PM motor when no frequency converter is connected and the shaft is turned externally. Back EMF is normally specified for nominal motor speed or for 1000 RPM measured between 2 lines. If the value is not available for a motor speed of 1000 RPM, calculate the correct value as follows: For example, if back EMF at 1800 RPM is 320 V, the back EMF at 1000 RPM is:
Back EMF=(Voltage/ RPM)x1000=(320/1800)x1000=178.
Program this value for *parameter 1-40 Back EMF at 1000 RPM.*

Test motor operation

1. Start the motor at low speed (100–200 RPM). If the motor does not turn, check installation, general programming, and motor data.

Parking

This function is the recommended option for applications where the motor rotates at slow speed (for example windmilling in fan applications). *Parameter 2-06 Parking Current* and *parameter 2-07 Parking Time* are adjustable. Increase the factory setting of these parameters for applications with high inertia.

Start the motor at nominal speed. If the application does not run well, check the VVC+ PM settings. *Table 5.13* shows recommendations in different applications.

Application	Settings
Low inertia applications $I_{Load}/I_{Motor} < 5$	<ul style="list-style-type: none"> • Increase the value for <i>parameter 1-17 Voltage filter time const.</i> by factor 5–10. • Reduce the value for <i>parameter 1-14 Damping Gain.</i> • Reduce the value (<100%) for <i>parameter 1-66 Min. Current at Low Speed.</i>
Medium inertia applications $50 > I_{Load}/I_{Motor} > 5$	Keep calculated values.
High inertia applications $I_{Load}/I_{Motor} > 50$	Increase the values for <i>parameter 1-14 Damping Gain</i> , <i>parameter 1-15 Low Speed Filter Time Const.</i> , and <i>parameter 1-16 High Speed Filter Time Const.</i>
High load at low speed <30% (rated speed)	Increase the value for <i>parameter 1-17 Voltage filter time const.</i> Increase the value for <i>parameter 1-66 Min. Current at Low Speed</i> (>100% for longer time can overheat the motor).

Table 5.13 Recommendations in Different Applications

If the motor starts oscillating at a certain speed, increase *parameter 1-14 Damping Gain*. Increase the value in small steps.

Starting torque can be adjusted in *parameter 1-66 Min. Current at Low Speed*. 100% provides nominal torque as starting torque.

5.4.3 Automatic Motor Adaptation (AMA)

To optimize compatibility between the frequency converter and the motor in VVC+ mode, run AMA.

- The frequency converter builds a mathematical model of the motor for regulating output motor current, thus enhancing motor performance.
- Some motors may be unable to run the complete version of the test. In that case, select [2] *Enable reduced AMA* in *parameter 1-29 Automatic Motor Adaption (AMA)*.
- If warnings or alarms occur, see *chapter 8.4 List of Warnings and Alarms*.
- For best results, run this procedure on a cold motor.

To run AMA using the LCP

1. By default parameter setting, connect terminals 13 and 27 before running AMA.
2. Enter the *Main Menu*.
3. Go to *parameter group 1-** Load and Motor*.
4. Press [OK].
5. Set motor parameters using nameplate data for *parameter group 1-2* Motor Data*.
6. Set motor cable length in *parameter 1-42 Motor Cable Length*.
7. Go to *parameter 1-29 Automatic Motor Adaption (AMA)*.
8. Press [OK].
9. Select [1] *Enable complete AMA*.
10. Press [OK].
11. The test runs automatically and indicates when it is complete.

Depending on the power size, the AMA takes 3–10 minutes to complete.

NOTICE

The AMA function does not cause the motor to run and it does not harm the motor.

5.5 Checking Motor Rotation

Before running the frequency converter, check the motor rotation.

1. Press [Hand On].
2. Press [▲] for positive speed reference.
3. Check that the speed shown is positive.
4. Verify that the wiring between the frequency converter and the motor is correct.
5. Verify that the motor running direction matches the setting in *parameter 1-06 Clockwise Direction*.
 - 5a When *parameter 1-06 Clockwise Direction* is set to [0] *Normal* (default clockwise):
 - a. Verify that the motor turns clockwise.
 - b. Verify that the LCP direction arrow is clockwise.
 - 5b When *parameter 1-06 Clockwise Direction* is set to [1] *Inverse* (counterclockwise):

- a. Verify that the motor turns counterclockwise.
- b. Verify that the LCP direction arrow is counterclockwise.

5.6 Checking Encoder Rotation

Only check encoder rotation if encoder feedback is used.

1. Select [0] *Open Loop* in *parameter 1-00 Configuration Mode*.
2. Select [1] *24 V encoder* in *parameter 7-00 Speed PID Feedback Source*.
3. Press [Hand On].
4. Press [▲] for positive speed reference (*parameter 1-06 Clockwise Direction* at [0] *Normal*).
5. Check in *parameter 16-57 Feedback [RPM]* that the feedback is positive.

NOTICE**NEGATIVE FEEDBACK**

If the feedback is negative, the encoder connection is wrong. Use *parameter 5-71 Term 32/33 Encoder Direction* to inverse the direction, or reverse the encoder cables.

5.7 Local-control Test

1. Press [Hand On] to provide a local start command to the frequency converter.
2. Accelerate the frequency converter by pressing [▲] to full speed. Moving the cursor left of the decimal point provides quicker input changes.
3. Note any acceleration problems.
4. Press [Off]. Note any deceleration problems.

If acceleration or deceleration problems occur, see *chapter 8.5 Troubleshooting*. See *chapter 8.2 Warning and Alarm Types* for resetting the frequency converter after a trip.

5.8 System Start-up

The procedure in this section requires user-wiring and application programming to be completed. The following procedure is recommended after application set-up is completed.

1. Press [Auto On].
2. Apply an external run command.
3. Adjust the speed reference throughout the speed range.
4. Remove the external run command.
5. Check the sound and vibration levels of the motor to ensure that the system is working as intended.

If warnings or alarms occur, see *chapter 8.2 Warning and Alarm Types* for resetting the frequency converter after a trip.

5.9 Memory Module

The VLT® Memory Module MCM is a small memory device containing data such as:

- Firmware for the frequency converter (not including the firmware for communication on the control card).
- PUD file.
- SIVP file.
- Parameter file.

The VLT® Memory Module MCM is an accessory. The frequency converter comes without the memory module installed from the factory. A new memory module can be ordered using the following ordering numbers.

Description	Ordering number
VLT® Memory Module MCM 102	132B0359
VLT® Memory Module MCM 103	132B0466

Table 5.14 Ordering Number

Each memory module has a unique serial number which cannot be modified.

NOTICE

The VLT® Memory Module MCM can be used on the frequency converter together with firmware 1.5 and above.

Select correct options for *parameter 31-40 Memory Module Function* before configuring with the memory module.

Parameter 31-40 Memory Module Function	Description
[0] Disabled	Downloading or uploading data function is disabled.
*[1] Only Allow Download	Only allow downloading data from the memory module to the frequency converter. This is the default setting of <i>parameter 31-40 Memory Module Function</i> .
[2] Only Allow Upload	Only allow uploading data from the frequency converter to the memory module.
[3] Allow Both Download and Upload	If this option is selected, the frequency converter downloads data from memory module first, and then uploads data from the frequency converter to the memory module.

Table 5.15 Description of *Parameter 31-40 Memory Module Function*

NOTICE

AVOID UNINTENTIONAL OVERWRITING

The default setting of *parameter 31-40 Memory Module Function* is [1] *Only Allow Download*. If there is any update, such as firmware updated by MCT 10 using OSS file, parameter updated by LCP or bus, parameters reset via *parameter 14-22 Operation Mode*, or 3-finger-reset of the frequency converter, the updated data will be lost after a new power cycle, because the frequency converter downloads data from the memory module again.

- After the data has been downloaded from the memory module to the frequency converter, select [0] *Disabled* or [2] *Only Allow Upload* in *parameter 31-40 Memory Module Function* before the new power cycle.

5.9.1 Synchronizing Frequency Converter Data to a New Memory Module (Create Drive Backup)

1. Plug a new empty memory module in the frequency converter.
2. Select [2] *Only Allow Upload* or [3] *Allow Both Download and Upload* in *parameter 31-40 Memory Module Function*.
3. Power up the frequency converter.
4. Wait until the synchronization is complete, refer to *chapter 5.9.7 Transfer Performance and Indications* to check the transfer indications on the frequency converter.

NOTICE

To avoid unintentional overwriting of the data in memory module, consider to adjust the settings for parameter 31-40 Memory Module Function before next power cycle according to different operating purpose.

5.9.2 Copying Data to Another Frequency Converter

1. Make sure that the required data are uploaded to the memory module, refer to *chapter 5.9.1 Synchronizing Frequency Converter Data to a New Memory Module (Create Drive Backup)*.
2. Unplug the memory module and plug into a new frequency converter.
3. Make sure that [1] Only Allow Download or [3] Allow Both Download and Upload is selected in parameter 31-40 Memory Module Function on the new frequency converter.
4. Power up the new frequency converter.
5. Wait until the download is complete and the data are transferred, refer to *chapter 5.9.7 Transfer Performance and Indications* to check the transfer indications on the frequency converter.

NOTICE

To avoid unintentional overwriting of the data in memory module, consider to adjust the settings for parameter 31-40 Memory Module Function before next power cycle according to different operating purpose.

5.9.3 Copying Data to Multiple Frequency Converters

If multiple frequency converters are of same voltage/power, the information of 1 frequency converter can be transferred to the others via 1 memory module.

1. Follow the steps in *chapter 5.9.1 Synchronizing Frequency Converter Data to a New Memory Module (Create Drive Backup)* to upload the data from 1 frequency converter to a memory module.
2. To avoid unintentional uploading of data to the master memory module, make sure that [1] Only Allow Download is selected in parameter 31-40 Memory Module Function on the other frequency converters.
3. Unplug the memory module and plug into a new frequency converter.
4. Power up the new frequency converter.

5. Wait until the download is complete and the data is transferred, refer to *chapter 5.9.7 Transfer Performance and Indications* to check the transfer indications on the frequency converter.
6. Repeat steps 3–5 for next frequency converter.

NOTICE

The data can also be downloaded to the memory module from a PC via the VLT® Memory Module Programmer.

NOTICE

In any of the frequency converters, if an empty memory module is plugged in for backing up data, adjust the settings for parameter 31-40 Memory Module Function to [2] Only Allow Upload or [3] Allow Both Download and Upload before next power cycle.

5.9.4 Transferring the Firmware Information

If 2 frequency converters are of same voltage and power size, the firmware information can be transferred from 1 frequency converter to another.

1. Follow the steps in *chapter 5.9.1 Synchronizing Frequency Converter Data to a New Memory Module (Create Drive Backup)* to upload the firmware information from 1 frequency converter to a memory module.
2. Follow the steps in *chapter 5.9.2 Copying Data to Another Frequency Converter* to transfer the firmware information to another frequency converter of same voltage and power size.

NOTICE

The firmware information can also be downloaded to the memory module from a PC via the VLT® Memory Module Programmer.

5.9.5 Backing Up Parameter Changes to Memory Module

1. Plug a new or erased memory module in the frequency converter.
2. Select [2] Only Allow Upload or [3] Allow Both Download and Upload in parameter 31-40 Memory Module Function.
3. Power up the frequency converter.
4. Wait until the synchronization is complete, refer to *chapter 5.9.7 Transfer Performance and Indications* to check the transfer indications on the frequency converter.
5. Any change to parameter settings is automatically synchronized to the memory module.

5.9.6 Erasing Data

The memory module can be erased via setting parameter 31-43 Erase_MM without a new power cycle.

1. Make sure that the memory module is mounted in the frequency converter.
2. Select [1] Erase MM in parameter 31-43 Erase_MM.
3. All files in the memory module are erased.
4. Parameter 31-43 Erase_MM setting returns to [0] No function.

5.9.7 Transfer Performance and Indications

The time for transferring different data between the frequency converter and the memory module is different, refer to Table 5.16.

Data file	Time
Firmware file	<ul style="list-style-type: none"> • It takes around 2 minutes for uploading data from the frequency converter to the memory module. • It takes around 6 minutes for downloading data from the memory module to the frequency converter.
SIVP file	Around 10 s.
Parameter file ¹⁾	Around 5 s.

Table 5.16 Transfer Performance

1) If a parameter is changed in the frequency converter, to upload the updated parameter, wait at least 5 s before power-down.

Data file	Indications		
	GLCP	NLCP	On LED ¹⁾
Firmware file	"Synchronizing with Memory Module." is shown during transferring.	No text indication.	The LED flashes slowly during the transfer.
SIVP file			The LED does not flash.
Parameter file	No text indication.		

Table 5.17 Transfer Indications

1) The On LED is on the LCP. Refer to chapter 5.3.1 Numeric Local Control Panel (NLCP) and chapter 5.3.5 Graphic Local Control Panel (GLCP) for the On LED's position and functions.

5.9.8 Activating the PROFIBUS Converter

VLT[®] Memory Module MCM 103 acts as a combination of both memory module and activation module to enable the PROFIBUS converter function in the firmware. VLT[®] Memory Module MCM 103 contains a PBconver.MME file, which is combined with the individual memory module

serial number. PBconver.MME is the key for the PROFIBUS converter function.

To activate the PROFIBUS converter, choose the version in parameter 14-70 Compatibility Selections.

Parameter 14-70 Compatibility Selections	Description
*[0] No Function	Selection of the compatibility function is disabled.
[12] VLT2800 3M	Select the VLT2800 3M compatibility mode for the frequency converter.
[13] VLT2800 3M incl. MAV	Select the VLT2800 3M incl. MAV compatibility mode for the frequency converter.
[14] VLT2800 12M	Select the VLT2800 12M compatibility mode for the frequency converter.
[15] VLT2800 12M incl. MAV	Select the VLT2800 12M incl. MAV compatibility mode for the frequency converter.

Table 5.18 Description of parameter 14-70 Compatibility Selections

Activate the PROFIBUS converter via VLT[®] Memory Module MCM 103

1. Plug the memory module in the frequency converter.
2. Select [12] VLT 2800 3M or [14] VLT 2800 12M in parameter 14-70 Compatibility Selections.
3. Make a power cycle to start the frequency converter as VLT[®] 2800 PROFIBUS identification number and mode.

NOTICE

For VLT[®] Memory Module MCM 103 to work as PROFIBUS converter, the parameter 31-40 Memory Module Function must not be set to [0] Disabled.

It is possible to activate the PROFIBUS converter without the VLT[®] Memory Module MCM 103 for a limited time. Before this time elapses, plug in a VLT[®] Memory Module MCM 103 to keep the PROFIBUS converter function.

Activate the PROFIBUS converter via parameter settings

1. Select [1] *Enabled* in *parameter 31-47 Time Limit Function*.
2. Select [12] *VLT 2800 3M* or [14] *VLT 2800 12M* in *parameter 14-70 Compatibility Selections*.
3. Make a power cycle to start the frequency converter as VLT® 2800 PROFIBUS identification number and mode.
4. *Parameter 31-48 Time Limit Remaining Time* starts to count down after the power cycle and shows the remaining time for use.

5

After 720 hours of running time, the frequency converter reports a warning. The PROFIBUS converter still works. When the time counter in *parameter 31-48 Time Limit Remaining Time* reaches 0, the frequency converter reports a trip lock alarm at the next start-up command.

6 Safe Torque Off (STO)

The Safe Torque Off (STO) function is a component in a safety control system. STO prevents the unit from generating the energy that is required to rotate the motor, thus ensuring safety in emergency situations.

The STO function is designed and approved suitable for the requirements of:

- IEC/EN 61508: 2010 SIL2
- IEC/EN 61800-5-2: 2007 SIL2
- IEC/EN 62061: 2012 SILCL of SIL2
- EN ISO 13849-1: 2008 Category 3 PL d

To achieve the required level of operational safety, select and apply the components in the safety control system appropriately. Before using STO, carry out a thorough risk analysis on the installation to determine whether the STO function and safety levels are appropriate and sufficient.

The STO function in the frequency converter is controlled via control terminals 37 and 38. When STO is activated, the power supply on the high side and low side of the IGBT gate driving circuits is cut off. *Illustration 6.1* shows the STO architecture. *Table 6.1* shows STO statuses based on whether terminals 37 and 38 are energized.

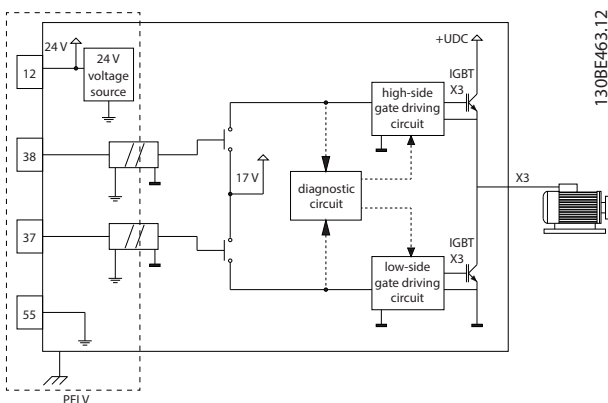

Illustration 6.1 STO Architecture

Terminal 37	Terminal 38	Torque	Warning or alarm
Energized ¹⁾	Energized	Yes ²⁾	No warnings or alarms.
De-energized ³⁾	De-energized	No	Warning/alarm 68: Safe Torque Off.
De-energized	Energized	No	Alarm 188: STO Function Fault.
Energized	De-energized	No	Alarm 188: STO Function Fault.

Table 6.1 STO Status

1) Voltage range is 24 V \pm 5 V, with terminal 55 as the reference terminal.

2) Torque is present only when the frequency converter is operating.

3) Open circuit, or the voltage within the range of 0 V \pm 1.5 V, with terminal 55 as the reference terminal.

Test pulse filtering

For safety devices that generate test pulses on the STO control lines: If the pulse signals stay at low level (≤ 1.8 V) for no longer than 5 ms, they are ignored, as shown in *Illustration 6.2*.

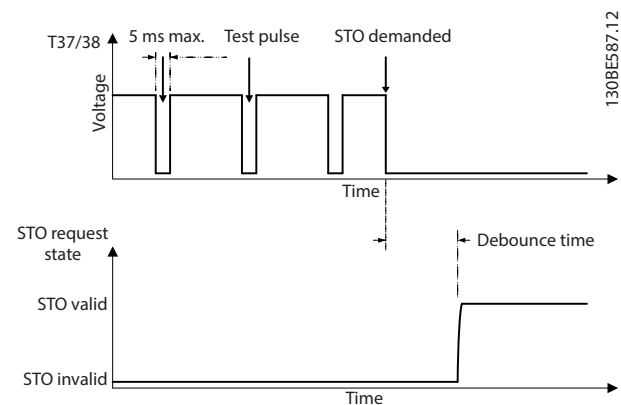

Illustration 6.2 Test Pulse Filtering

Asynchronous input tolerance

The input signals at the 2 terminals are not always synchronous. If the discrepancy between the 2 signals is longer than 12 ms, the STO fault alarm (*alarm 188, STO Function Fault*) occurs.

Valid signals

To activate STO, the 2 signals must both be at low level for at least 80 ms. To terminate STO, the 2 signals must both be at high level for at least 20 ms. Refer to *chapter 9.6 Control Input/Output and Control Data* for the voltage levels and input current of STO terminals.

6.1 Safety Precautions for STO

Qualified personnel

Only qualified personnel are allowed to install or operate this equipment.

Qualified personnel are defined as trained staff, who are authorized to install, commission, and maintain equipment, systems, and circuits in accordance with pertinent laws and regulations. Also, the personnel must be familiar with the instructions and safety measures described in this manual.

NOTICE

After installation of STO, perform a commissioning test as specified in *chapter 6.3.3 STO Commissioning Test*. A passed commissioning test is mandatory after first installation and after each change to the safety installation.

⚠ WARNING

RISK OF ELECTRICAL SHOCK

The STO function does NOT isolate mains voltage to the frequency converter or auxiliary circuits, and therefore does not provide electrical safety. Failure to isolate the mains voltage supply from the unit and wait the time specified could result in death or serious injury.

- Perform work on electrical parts of the frequency converter or the motor only after isolating the mains voltage supply and waiting the time specified in *chapter 2.3.1 Discharge Time*.

NOTICE

When designing the machine application, consider the timing and distance for a coast to stop (STO). For more information regarding stop categories, refer to EN 60204-1.

6.2 Safe Torque Off Installation

For motor connection, AC mains connection, and control wiring, follow the instructions for safe installation in *chapter 4 Electrical Installation*.

Enable the integrated STO as follows:

1. Remove the jumper between control terminals 12 (24 V), 37, and 38. Cutting or breaking the jumper is not sufficient to avoid short-circuiting. See the jumper in *Illustration 6.3*.

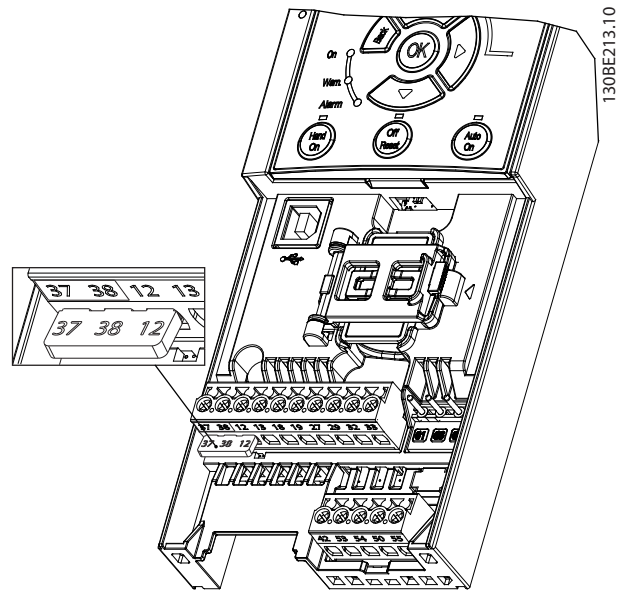
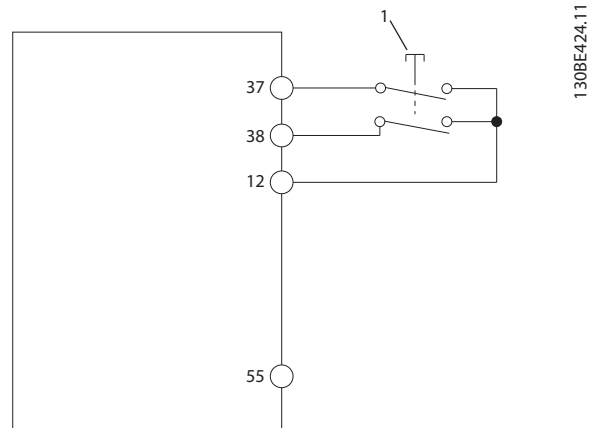

Illustration 6.3 Jumper between Terminal 12 (24 V), 37, and 38

2. Connect a dual-channel safety device (for example safety PLC, light curtain, safety relay, or emergency stop button) to terminals 37 and 38 to form a safety application. The device must comply with the required safety level based on the hazard assessment. *Illustration 6.4* shows the wiring schematic of STO applications where the frequency converter and the safety device are in the same cabinet. *Illustration 6.5* shows the wiring schematic of STO applications where external supply is used.

NOTICE

The STO signal must be PELV supplied.



1	Safety device
---	---------------

Illustration 6.4 STO Wiring in 1 Cabinet, the Frequency Converter Provides the Supply Voltage

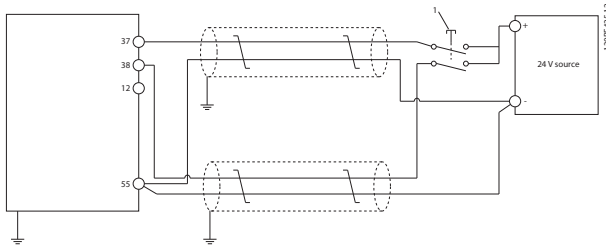

1	Safety device
---	---------------

Illustration 6.5 STO Wiring, External Supply

3. Complete the wiring according to the instructions in *chapter 4 Electrical Installation*, and:
 - 3a Eliminate short circuit risks.
 - 3b Ensure that the STO cables are shielded if they are longer than 20 m (65.6 ft) or outside the cabinet.
 - 3c Connect the safety device directly to terminals 37 and 38.

6.3 STO Commissioning

6.3.1 Activation of Safe Torque Off

To activate the STO function, remove the voltage at terminals 37 and 38 of the frequency converter.

When STO is activated, the frequency converter issues *alarm 68, Safe Torque Off* or *warning 68, Safe Torque Off*, trips the unit, and coasts the motor to stop. Use the STO function to stop the frequency converter in emergency stop situations. In normal operating mode when STO is not required, use the standard stop function instead.

NOTICE

If STO is activated while the frequency converter issues *warning 8, DC undervoltage* or *alarm 8, DC undervoltage*, the frequency converter skips *alarm 68, Safe Torque Off*, but the STO operation is not affected.

6.3.2 Deactivation of Safe Torque Off

Follow the instructions in *Table 6.2* to deactivate the STO function and resume normal operation based on the restart mode of the STO function.

WARNING

RISK OF INJURY OR DEATH

Reapplying 24 V DC supply to either terminal 37 or 38 terminates the SIL2 STO state, potentially starting the motor. Unexpected motor start may cause personal injuries or death.

- Ensure that all safety measures are taken before reapplying 24 V DC supply to terminals 37 and 38.

Restart mode	Steps to deactivate STO and resume normal operation	Restart mode configuration
Manual restart	<ol style="list-style-type: none"> 1. Reapply 24 V DC supply to terminals 37 and 38. 2. Initiate a reset signal (via fieldbus, digital I/O, or [Reset]/[Off Reset] key on the LCP). 	Default setting. <i>Parameter 5-19 Terminal 37/38 Safe Torque Off=[1]</i> <i>Safe Torque Off Alarm</i>
Automatic restart	Reapply 24 V DC supply to terminals 37 and 38.	<i>Parameter 5-19 Terminal 37/38 Safe Torque Off= [3]</i> <i>Safe Torque Off Warning.</i>

Table 6.2 STO Deactivation

6.3.3 STO Commissioning Test

After installation and before first operation, perform a commissioning test of the installation using STO. Perform the test again after each modification of the installation or application involving the STO.

NOTICE

A successful commissioning test of the STO function is required after the initial installation, and after each subsequent change to the installation.

To perform a commissioning test:

- Follow the instructions in *chapter 6.3.4 Test for STO Applications in Manual Restart Mode* if STO is set to manual restart mode.
- Follow the instructions in *chapter 6.3.5 Test for STO Applications in Automatic Restart Mode* if STO is set to automatic restart mode.

6.3.4 Test for STO Applications in Manual Restart Mode

For applications where *parameter 5-19 Terminal 37/38 Safe Torque Off* is set to the default value [1] *Safe Torque Off Alarm*, conduct the commissioning test as follows:

1. Set *parameter 5-40 Function Relay* to [190] *Safe Function active*.
2. Remove the 24 V DC voltage supply to terminals 37 and 38 using the safety device while the frequency converter drives the motor (that is, the mains supply is not interrupted).
3. Verify that:
 - 3a The motor coasts. It may take a long time for the motor to stop.
 - 3b If the LCP is mounted, *alarm 68, Safe Torque Off* shows on the LCP. If the LCP is not mounted, *alarm 68, Safe Torque Off* is logged in *parameter 15-30 Alarm Log: Error Code*.
4. Reapply 24 V DC to terminals 37 and 38.
5. Ensure that the motor remains in the coasted state, and the customer relay (if connected) remains activated.
6. Send reset signal (via fieldbus, digital I/O, or [Reset]/[Off Reset] key on the LCP).
7. Ensure that the motor becomes operational and runs within the original speed range.

The commissioning test is successfully completed when all the above-mentioned steps are passed.

6.3.5 Test for STO Applications in Automatic Restart Mode

For applications where *parameter 5-19 Terminal 37/38 Safe Torque Off* is set to [3] *Safe Torque Off Warning*, conduct the commissioning test as follows:

1. Remove the 24 V DC voltage supply to terminals 37 and 38 by the safety device while the frequency converter drives the motor (that is, the mains supply is not interrupted).
2. Verify that:
 - 2a The motor coasts. It may take a long time for the motor to stop.
 - 2b If the LCP is mounted *Warning 68, Safe Torque Off W68*, shows on the LCP. If the LCP is not mounted, *Warning 68, Safe Torque Off W68* is logged in bit 30 of *parameter 16-92 Warning Word*.
3. Reapply 24 V DC to terminals 37 and 38.

4. Ensure that the motor becomes operational and runs within the original speed range.

The commissioning test is successfully completed when all the above-mentioned steps are passed.

NOTICE

See the warning on the restart behavior in *chapter 6.1 Safety Precautions for STO*.

6.4 Maintenance and Service for STO

- The user is responsible for security measures.
- The frequency converter parameters can be protected with a password.

The functional test consists of 2 parts:

- Basic functional test.
- Diagnostic functional test.

When all the steps are completed successfully, the functional test is successful.

Basic functional test

If the STO function has not been used for 1 year, conduct a basic functional test to detect any failure or malfunction of STO.

1. Ensure that *parameter 5-19 Terminal 37/38 Safe Torque Off* is set to *[1] *Safe Torque Off Alarm*.
2. Remove the 24 V DC voltage supply for terminals 37 and 38.
3. Check if the LCP shows *alarm 68, Safe Torque Off*.
4. Verify that the frequency converter trips the unit.
5. Verify that the motor is coasting and stops completely.
6. Initiate a start signal (via fieldbus, digital I/O, or the LCP), and verify that the motor does not start.
7. Reconnect the 24 V DC voltage supply to terminals 37 and 38.
8. Verify that the motor is not started automatically and restarts only by giving a reset signal (via fieldbus, digital I/O, or [Reset]/[Off Reset] key on the LCP).

Diagnostic functional test

1. Verify that *warning 68, Safe Torque Off* and *alarm 68, Safe Torque Off* do not occur when 24 V supply is connected to terminals 37 and 38.
2. Remove the 24 V supply for terminal 37, and verify that the LCP shows *alarm 188, STO Function Fault* if the LCP is mounted. If the LCP is not mounted, verify that *alarm 188, STO Function Fault* is logged in *parameter 15-30 Alarm Log: Error Code*.
3. Reapply 24 V supply to terminal 37, and verify that resetting the alarm is successful.

4. Remove the 24 V supply for terminal 38 and verify that the LCP shows *alarm 188, STO Function Fault* if the LCP is mounted. If the LCP is not mounted, verify that *alarm 188, STO Function Fault* is logged in *parameter 15-30 Alarm Log: Error Code*.
5. Reapply 24 V supply to terminal 38 and verify that resetting the alarm is successful.

6.5 STO Technical Data

The Failure Modes, Effects, and Diagnostic Analysis (FMEDA) is performed based on the following assumptions:

- VLT® Midi Drive FC 280 takes 10% of the total failure budget for an SIL2 safety loop.
- Failure rates are based on the Siemens SN29500 database.
- Failure rates are constant; wear-out mechanisms are not included.
- For each channel, the safety-related components are considered to be of type A with a hardware fault tolerance of 0.
- The stress levels are average for an industrial environment and the working temperature of components is up to 85 °C (185 °F).
- A safe error (for example output in safe state) is repaired within 8 hours.
- No torque output is the safe state.

Safety standards	Safety of Machinery	ISO 13849-1, IEC 62061
	Functional Safety	IEC 61508
Safety function	Safe Torque Off	IEC 61800-5-2
Safety performance	ISO 13849-1	
	Category	Cat. 3
	Diagnostic coverage (DC)	60% (Low)
	Mean time to dangerous failure (MTTFd)	2400 years (High)
	Performance level	PL d
	IEC 61508/IEC 61800-5-2/IEC 62061	
	Safety Integrity Level	SIL2
	Probability of dangerous failure per hour (PFH) (high demand mode)	7.54E-9 (1/h)
	Probability of dangerous failure on demand (PFD _{avg} for PTI = 20 years) (low demand mode)	6.05E-4
	Safe failure fraction (SFF)	For dual-channel parts: >84%
		For single-channel parts: >99%
	Hardware fault tolerance (HFT)	For dual-channel parts: HFT = 1
		For single-channel parts: HFT = 0
	Proof test interval ²⁾	20 years
Common cause failure (CCF)	β = 5%; β _D = 5%	
Diagnostic test interval (DTI)	160 ms	
Systematic capability	SC 2	
Reaction time ¹⁾	Input to output response time	Enclosure sizes K1–K3: Maximum 50 ms Enclosure sizes K4 and K5: Maximum 30 ms

Table 6.3 Technical Data for STO

1) Reaction time is the amount of time from an input signal condition triggers the STO until the torque is off on the motor.

2) For proof test procedure, refer to chapter 6.4 Maintenance and Service for STO.

7 Application Examples

7.1 Introduction

The examples in this section are intended as a quick reference for common applications.

- Parameter settings are the regional default values unless otherwise indicated (selected in *parameter 0-03 Regional Settings*).
- Parameters associated with the terminals and their settings are shown next to the drawings.
- Required switch settings for analog terminals 53 or 54 are also shown.

NOTICE

When the STO feature is not used, a jumper wire is required between terminals 12, 37, and 38 for the frequency converter to operate with factory default programming values.

7.2 Application Examples

7.2.1 AMA

		Parameters	
		Function	Setting
		Parameter 1-29 Automatic Motor Adaptation (AMA)	[1] Enable complete AMA
		Parameter 5-12 Terminal 27 Digital Input	*[2] Coast inverse
		* = Default value	
		Notes/comments: Set parameter group 1-2* Motor Data according to motor specifications.	
		NOTICE If terminal 13 and 27 are not connected, set parameter 5-12 Terminal 27 Digital Input to [0] No operation.	

Table 7.1 AMA with T27 Connected

7.2.2 Speed

		Parameters	
		Function	Setting
		Parameter 6-10 Terminal 53 Low Voltage	0.07 V*
		Parameter 6-11 Terminal 53 High Voltage	10 V*
		Parameter 6-14 Terminal 53 Low Ref./Feedb. Value	0
		Parameter 6-15 Terminal 53 High Ref./Feedb. Value	50
		Parameter 6-19 Terminal 53 mode	[1] Voltage
		* = Default value	
		Notes/comments:	

Table 7.2 Analog Speed Reference (Voltage)

		Parameters	
		Function	Setting
		Parameter 6-22 Terminal 54 Low Current	4 mA*
		Parameter 6-23 Terminal 54 High Current	20 mA*
		Parameter 6-24 Terminal 54 Low Ref./Feedb. Value	0
		Parameter 6-25 Terminal 54 High Ref./Feedb. Value	50
		Parameter 6-29 Terminal 54 mode	[0] Current
		* = Default value	
		Notes/comments:	

Table 7.3 Analog Speed Reference (Current)

FC		Parameters	
		Function	Setting
+24 V	12	Parameter 6-10 Terminal 53 Low Voltage	0.07 V*
+24 V	13	Parameter 6-11 Terminal 53 High Voltage	10 V*
D IN	18	Parameter 6-14 Terminal 53 Low Ref./Feedb. Value	0
D IN	19	Parameter 6-15 Terminal 53 High Ref./Feedb. Value	50
D IN	27	Parameter 6-19 Terminal 53 mode	[1] Voltage
D IN	29	* = Default value	
D IN	32	Notes/comments:	
D IN	33		
+10 V	50		
A IN	53		
A IN	54		
COM	55		
A OUT	42		

Table 7.4 Speed Reference (Using a Manual Potentiometer)

FC		Parameters	
		Function	Setting
+24 V	12	Parameter 5-10 Terminal 18 Digital Input	*[8] Start
+24 V	13	Parameter 5-12 Terminal 27 Digital Input	[19] Freeze Reference
D IN	18	Parameter 5-13 Terminal 29 Digital Input	[21] Speed Up
D IN	19	Parameter 5-14 Terminal 32 Digital Input	[22] Speed Down
D IN	27	* = Default value	
D IN	29	Notes/comments:	
D IN	32		
D IN	33		
+10 V	50		
A IN	53		
A IN	54		
COM	55		
A OUT	42		

Table 7.5 Speed Up/Speed Down

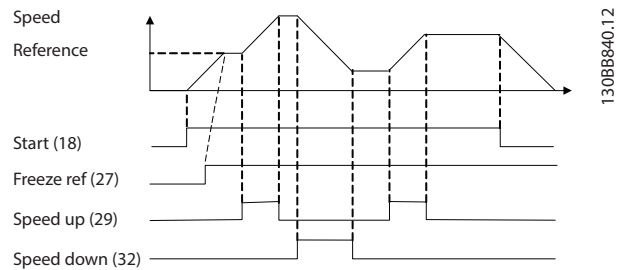

Illustration 7.1 Speed Up/Speed Down

7.2.3 Start/Stop

FC		Parameters	
		Function	Setting
+24 V	12	Parameter 5-10 Terminal 18 Digital Input	[8] Start
+24 V	13	Parameter 5-11 Terminal 19 Digital Input	*[10] Reversing
D IN	18	Parameter 5-12 Terminal 27 Digital Input	[0] No operation
D IN	19	Parameter 5-14 Terminal 32 Digital Input	[16] Preset ref bit 0
D IN	27	Parameter 5-15 Terminal 33 Digital Input	[17] Preset ref bit 1
D IN	29	Parameter 3-10 Preset Reference	Preset ref. 0: 25%
D IN	32		Preset ref. 1: 50%
D IN	33		Preset ref. 2: 75%
+10 V	50		Preset ref. 3: 100%
A IN	53	* = Default value	
A IN	54	Notes/comments:	
COM	55		
A OUT	42		

Table 7.6 Start/Stop with Reversing and 4 Preset Speeds

7.2.4 External Alarm Reset

		Parameters	
FC		Function	Setting
+24 V	12	Parameter 5-11 Terminal 19 Digital Input	[1] Reset
+24 V	13		
D IN	18	* = Default value	
D IN	19	Notes/comments:	
D IN	27		
D IN	29		
D IN	32		
D IN	33		
+10 V	50		
A IN	53		
A IN	54		
COM	55		
A OUT	42		

Table 7.7 External Alarm Reset

7.2.5 Motor Thermistor

NOTICE

To meet PELV insulation requirements, use reinforced or double insulation on the thermistors.

		Parameters	
FC		Function	Setting
+24 V	12	Parameter 1-90 Motor Thermal Protection	[2] Thermistor trip
+24 V	13		
D IN	18	Parameter 1-93 Thermistor Source	[1] Analog input 53
D IN	19		
D IN	27	Parameter 6-19 Terminal 53 mode	[1] Voltage
D IN	29		
D IN	32	* = Default value	
D IN	33	Notes/comments: If only a warning is needed, set parameter 1-90 Motor Thermal Protection to [1] Thermistor warning.	
+10 V	50		
A IN	53		
A IN	54		
COM	55		
A OUT	42		

Table 7.8 Motor Thermistor

7.2.6 SLC

		Parameters	
FC		Function	Setting
+24 V	12	Parameter 4-30 Motor Feedback Loss Function	[1] Warning
+24 V	13		
D IN	18	Parameter 4-31 Motor Feedback Speed Error	50
D IN	19		
D IN	27	Parameter 4-32 Motor Feedback Loss Timeout	5 s
D IN	29		
D IN	32	Parameter 7-00 Speed PID Feedback Source	[1] 24 V encoder
D IN	33		
+10 V	50	Parameter 5-70 Term 32/33 Pulses Per Revolution	1024*
A IN	53		
A IN	54	Parameter 13-00 SL Controller Mode	[1] On
COM	55		
A OUT	42	Parameter 13-01 Start Event	[19] Warning
		Parameter 13-02 Stop Event	[44] Reset key
		Parameter 13-10 Comparator Operand	[21] Warning no.
		Parameter 13-11 Comparator Operator	*[1] ≈
		Parameter 13-12 Comparator Value	61
		Parameter 13-51 SL Controller Event	[22] Comparator 0
		Parameter 13-52 SL Controller Action	[32] Set digital out A low
		Parameter 5-40 Function Relay	[80] SL digital output A
		* = Default value	
		Notes/comments: If the limit in the feedback monitor is exceeded, warning 61, feedback monitor is issued. The SLC monitors warning 61, feedback monitor. If warning 61, feedback monitor becomes true, relay 1 is triggered. External equipment could indicate that service is required. If the feedback error goes below the limit again within 5 s, the frequency converter continues, and the warning disappears. Relay 1 persists until [Off/Reset] is pressed.	

Table 7.9 Using SLC to Set a Relay

8 Maintenance, Diagnostics, and Troubleshooting

8.1 Maintenance and Service

Under normal operating conditions and load profiles, the frequency converter is maintenance-free throughout its designed lifetime. To prevent breakdown, danger, and damage, examine the frequency converter for terminal connections tightness, dust entry, and so on at regular intervals depending on the operating conditions. Replace worn or damaged parts with original spare parts or standard parts. For service and support, contact the local Danfoss supplier.

⚠ WARNING

UNINTENDED START

When the frequency converter is connected to AC mains, DC supply, or load sharing, the motor may start at any time. Unintended start during programming, service, or repair work can result in death, serious injury, or property damage. The motor can start with an external switch, a fieldbus command, an input reference signal from the LCP, via remote operation using MCT 10 Set-up Software, or after a cleared fault condition.

To prevent unintended motor start:

- Disconnect the frequency converter from the mains.
- Press [Off/Reset] on the LCP before programming parameters.
- Completely wire and assemble the frequency converter, motor, and any driven equipment before connecting the frequency converter to AC mains, DC supply, or load sharing.

8.2 Warning and Alarm Types

Warning/ alarm type	Description
Warning	A warning indicates an abnormal operating condition that leads to an alarm. A warning stops when the abnormal condition is removed.
Alarm	An alarm indicates a fault that requires immediate attention. The fault always triggers a trip or trip lock. Reset the drive after an alarm. Reset the drive in any of 4 ways: <ul style="list-style-type: none"> • Press [Reset]/[Off/Reset]. • Digital reset input command. • Serial communication reset input command. • Auto reset.

Trip

When tripping, the drive suspends operation to prevent damage to the drive and other equipment. When a trip occurs, the motor coasts to a stop. The drive logic continues to operate and monitor the drive status. After the fault condition is remedied, the drive is ready for a reset.

Trip lock

When trip locking, the drive suspends operation to prevent damage to the drive and other equipment. When a trip lock occurs, the motor coasts to a stop. The drive logic continues to operate and monitor the drive status. The drive starts a trip lock only when serious faults occur that can damage the drive or other equipment. After the faults are fixed, cycle the input power before resetting the drive.

8.3 Warning and Alarm Display

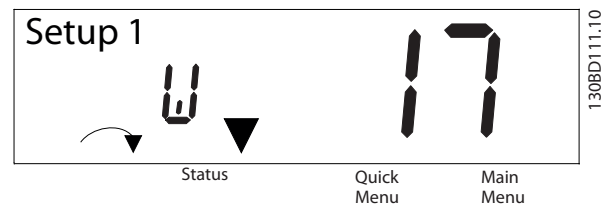

Illustration 8.1 Warning Display

An alarm or trip-lock alarm shows in the display along with the alarm number.

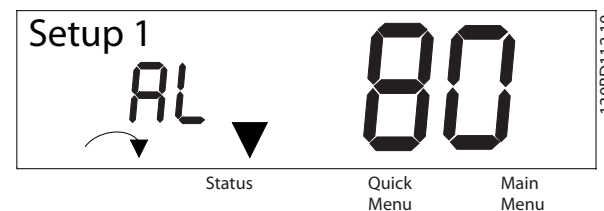
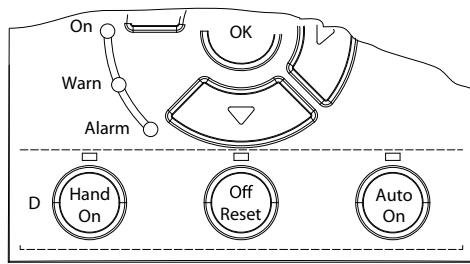

Illustration 8.2 Alarm/Trip Lock Alarm

In addition to the text and alarm code on the frequency converter display, there are 3 status indicator lights. The warning indicator light is yellow during a warning. The alarm indicator light is red and flashing during an alarm.



130BD062.10

Illustration 8.3 Status Indicator Lights

8.4 List of Warnings and Alarms

8.4.1 Warning and Alarm Code List

An (X) marked in *Table 8.1* indicates that the warning or alarm has occurred.

No.	Description	Warning	Alarm	Trip lock	Cause
2	Live zero error	X	X	–	The signal on terminal 53 or 54 is less than 50% of the value set in <i>parameter 6-10 Terminal 53 Low Voltage</i> , <i>parameter 6-20 Terminal 54 Low Voltage</i> , and <i>parameter 6-22 Terminal 54 Low Current</i> .
3	No motor	X	–	–	No motor has been connected to the output of the frequency converter.
4	Mains phase loss ¹⁾	X	X	X	Missing phase on the supply side, or the voltage imbalance is too high. Check the supply voltage.
7	DC overvoltage ¹⁾	X	X	–	DC-link voltage exceeds limit.
8	DC undervoltage ¹⁾	X	X	–	DC-link voltage drops below the voltage warning low limit.
9	Inverter overloaded	X	X	–	More than 100% load for too long.
10	Motor ETR overtemperature	X	X	–	Motor is too hot due to more than 100% load for too long.
11	Motor thermistor overtemperature	X	X	–	Thermistor or thermistor connection is disconnected, or the motor is too hot.
12	Torque limit	X	X	–	Torque exceeds the value set in either <i>parameter 4-16 Torque Limit Motor Mode</i> or <i>parameter 4-17 Torque Limit Generator Mode</i> .
13	Overcurrent	X	X	X	Inverter peak current limit is exceeded. If this alarm occurs on power-up, check whether power cables are mistakenly connected to the motor terminals.
14	Ground fault	–	X	X	Discharge from output phases to ground.
16	Short circuit	–	X	X	Short circuit in motor or on motor terminals.
17	Control word timeout	X	X	–	No communication to frequency converter.
25	Brake resistor short-circuited	–	X	X	Brake resistor is short-circuited, thus the brake function is disconnected.
26	Brake overload	X	X	–	The power transmitted to the brake resistor over the last 120 s exceeds the limit. Possible corrections: Decrease brake energy via lower speed or longer ramp time.
27	Brake IGBT/brake chopper short-circuited	–	X	X	Brake transistor is short-circuited, thus the brake function is disconnected.
28	Brake check	–	X	–	Brake resistor is not connected/working.
30	U phase loss	–	X	X	Motor phase U is missing. Check the phase.
31	V phase loss	–	X	X	Motor phase V is missing. Check the phase.
32	W phase loss	–	X	X	Motor phase W is missing. Check the phase.
34	Fieldbus fault	X	X	–	PROFIBUS communication issues have occurred.
35	Option fault	–	X	–	Fieldbus detects internal faults.
36	Mains failure	X	X	–	This warning/alarm is only active if the supply voltage to the frequency converter is less than the value set in <i>parameter 14-11 Mains Fault Voltage Level</i> , and <i>parameter 14-10 Mains Failure</i> is NOT set to [0] No Function.
38	Internal fault	–	X	X	Contact the local Danfoss supplier.
40	Overload T27	X	–	–	Check the load connected to terminal 27 or remove short-circuit connection.
46	Gate drive voltage fault	–	X	X	–
47	24 V supply low	X	X	X	24 V DC may be overloaded.

No.	Description	Warning	Alarm	Trip lock	Cause
49	Speed limit	-	X	-	The motor speed is below the specified limit in <i>parameter 1-87 Trip Speed Low [Hz]</i> .
50	AMA calibration failed	-	X	-	A calibration error has occurred.
51	AMA check U_{nom} and I_{nom}	-	X	-	Wrong setting for motor voltage and/or motor current.
52	AMA low I_{nom}	-	X	-	Motor current is too low. Check the settings.
53	AMA big motor	-	X	-	The power size of the motor is too large for the AMA to operate.
54	AMA small motor	-	X	-	The power size of the motor is too small for the AMA to operate.
55	AMA parameter range	-	X	-	The parameter values of the motor are outside of the acceptable range. AMA does not run.
56	AMA interrupt	-	X	-	The AMA is interrupted.
57	AMA timeout	-	X	-	-
58	AMA internal	-	X	-	Contact Danfoss.
59	Current limit	X	X	-	Frequency converter overload.
60	External interlock	-	X	-	External interlock has been activated.
61	Encoder loss	X	X	-	-
63	Mechanical brake low	-	X	-	The actual motor current has not exceeded the release brake current within the start delay time window.
65	Control card temp	X	X	X	The cutout temperature of the control card has exceeded the upper limit.
67	Option change	-	X	-	A new option is detected or a mounted option is removed.
68	Safe Torque Off ²⁾	X	X	-	STO is activated. If STO is in manual restart mode (default), to resume normal operation, apply 24 V DC to terminals 37 and 38, and initiate a reset signal (via fieldbus, digital I/O, or [Reset]/[Off Reset] key). If STO is in automatic restart mode, applying 24 V DC to terminals 37 and 38 automatically resumes the frequency converter to normal operation.
69	Power card temp	X	X	X	The cutout temperature of the power card has exceeded the upper limit.
80	Drive initialized to default value	-	X	-	All parameter settings are initialized to default settings.
87	Auto DC braking	X	-	-	Occurs in IT mains when the frequency converter coasts, and the DC voltage is higher than 830 V for 400 V units and 425 V for 200 V units. The motor consumes energy on the DC link. This function can be enabled/disabled in <i>parameter 0-07 Auto DC Braking</i> .
88	Option detection	-	X	X	The option is removed successfully.
95	Broken belt	X	X	-	-
99	Locked rotor	-	X	-	Rotor is blocked.
120	Position control fault	-	X	-	-
126	Motor rotating	-	X	-	PM motor is rotating when AMA is performed.
127	Back EMF too high	X	-	-	The back EMF of PM motor is too high before starting.
188	STO internal fault ²⁾	-	X	-	24 V DC supply is connected to only 1 of the 2 STO terminals (37 and 38), or a failure in STO channels is detected. Ensure that both terminals are powered by a 24 V DC supply, and that the discrepancy between the signals at the 2 terminals is less than 12 ms. If the fault still occurs, contact the local Danfoss supplier.
nw run	Not while running	-	-	-	Parameters can only be changed when the motor is stopped.

No.	Description	Warning	Alarm	Trip lock	Cause
Err.	A wrong password was entered	-	-	-	Occurs when using a wrong password for changing a password-protected parameter.

Table 8.1 Warnings and Alarms Code List

1) Mains distortions may cause these faults. Installing a Danfoss line filter may rectify this problem.

2) This alarm cannot be reset via parameter 14-20 Reset Mode automatically.

For diagnosis, read out the alarm words, warning words, and extended status words.

Bit	Hex	Dec	Alarm word (parameter 1 6-90 Alarm Word)	Alarm word 2 (parameter 16-91 Alarm Word 2)	Alarm word 3 (parameter 1 6-97 Alarm Word 3)	Warning word (parameter 16- 92 Warning Word)	Warning word 2 (parameter 16 -93 Warning Word 2)	Extended status word (parameter 16- 94 Ext. Status Word)	Extended status word 2 (parameter 16-95 Ext . Status Word 2)
0	000000 01	1	Brake check	Reserved	STO function fault	Reserved	Reserved	Ramping	Off
1	000000 02	2	Pwr. card temp	Gate drive voltage fault	MM alarm	Pwr. card temp	Reserved	AMA tuning	Hand/Auto
2	000000 04	4	Earth fault	Reserved	Reserved	Reserved	Reserved	Start CW/CCW	Profibus OFF1 active
3	000000 08	8	Ctrl. card temp	Reserved	Reserved	Ctrl. card temp	Reserved	Slowdown	Profibus OFF2 active
4	000000 10	16	Ctrl. word TO	Reserved	Reserved	Ctrl. word TO	Reserved	Catchup	Profibus OFF3 active
5	000000 20	32	Overcurrent	Reserved	Reserved	Overcurrent	Reserved	Feedback high	Reserved
6	000000 40	64	Torque limit	Reserved	Reserved	Torque limit	Reserved	Feedback low	Reserved
7	000000 80	128	Motor Th. over	Reserved	Reserved	Motor Th. over	Reserved	Output current high	Control ready
8	000001 00	256	Motor ETR over	Broken belt	Reserved	Motor ETR over	Broken belt	Output current low	Frequency converter ready
9	000002 00	512	Inverter overld.	Reserved	Reserved	Inverter overld.	Reserved	Output freq. high	Quick stop
10	000004 00	1024	DC undervolt.	Start failed	Reserved	DC undervolt.	Reserved	Output freq. low	DC brake
11	000008 00	2048	DC overvolt.	Speed limit	Reserved	DC overvolt.	Reserved	Brake check OK	Stop
12	000010 00	4096	Short circuit	External interlock	Reserved	Reserved	Reserved	Braking max	Reserved
13	000020 00	8192	Reserved	Reserved	Reserved	Reserved	Reserved	Braking	Freeze output request
14	000040 00	16384	Mains ph. loss	Reserved	Reserved	Mains ph. loss	Reserved	Reserved	Freeze output
15	000080 00	32768	AMA not OK	Reserved	Reserved	No motor	Auto DC braking	OVC active	Jog request
16	000100 00	65536	Live zero error	Reserved	Reserved	Live zero error	Reserved	AC brake	Jog
17	000200 00	131072	Internal fault	Reserved	Reserved	Reserved	Reserved	Reserved	Start request

Bit	Hex	Dec	Alarm word (parameter 1 6-90 Alarm Word)	Alarm word 2 (parameter 16-91 Alarm Word 2)	Alarm word 3 (parameter 1 6-97 Alarm Word 3)	Warning word (parameter 16- 92 Warning Word)	Warning word 2 (parameter 16 -93 Warning Word 2)	Extended status word (parameter 16- 94 Ext. Status Word)	Extended status word 2 (parameter 16-95 Ext . Status Word 2)
18	000400 00	262144	Brake overload	Reserved	Reserved	Brake resistor power limit	Reserved	Reserved	Start
19	000800 00	524288	U phase loss	Reserved	Reserved	Reserved	Reserved	Reference high	Reserved
20	001000 00	1048576	V phase loss	Option detection	Reserved	Reserved	Overload T27	Reference low	Start delay
21	002000 00	2097152	W phase loss	Option fault	Reserved	Reserved	Reserved	Reserved	Sleep
22	004000 00	4194304	Fieldbus fault	Locked rotor	Reserved	Fieldbus fault	Memory module	Reserved	Sleep boost
23	008000 00	8388608	24 V supply low	Position ctrl. fault	Reserved	24 V supply low	Reserved	Reserved	Running
24	010000 00	16777216	Mains failure	Reserved	Reserved	Mains failure	Reserved	Reserved	Bypass
25	020000 00	33554432	Reserved	Current limit	Reserved	Current limit	Reserved	Reserved	Reserved
26	040000 00	67108864	Brake resistor	Reserved	Reserved	Reserved	Reserved	Reserved	External interlock
27	080000 00	13421772 8	Brake IGBT	Reserved	Reserved	Reserved	Reserved	Reserved	Reserved
28	100000 00	26843545 6	Option change	Reserved	Reserved	Encoder loss	Reserved	Reserved	FlyStart active
29	200000 00	53687091 2	Frequency converter initialized	Encoder loss	Reserved	Reserved	Back EMF too high	Reserved	Heat sink clean warning
30	400000 00	10737418 24	Safe Torque Off	Reserved	Reserved	Safe Torque Off	Reserved	Reserved	Reserved
31	800000 00	21474836 48	Mech. brake low	Reserved	Reserved	Reserved	Reserved	Database busy	Reserved

Table 8.2 Description of Alarm Word, Warning Word, and Extended Status Word

8.5 Troubleshooting

Symptom	Possible cause	Test	Solution
Motor not running	LCP stop	Check if [Off] has been pressed.	Press [Auto On] or [Hand On] (depending on operating mode) to run the motor.
	Missing start signal (standby)	Check <i>parameter 5-10 Terminal 18 Digital Input</i> of correct setting for terminal 18 (use default setting).	Apply a valid start signal to start the motor.
	Motor coast signal active (coasting)	Check <i>parameter 5-12 Terminal 27 Digital Input</i> for correct setting of terminal 27 (use default setting).	Apply 24 V on terminal 27 or program this terminal to [0] <i>No operation</i> .
	Wrong reference signal source	Check the following: <ul style="list-style-type: none"> • The reference signal is local, remote, or bus reference? • Preset reference is active? • Terminal connection is correct? • The scaling of terminals is correct? • The reference signal is available? 	Program correct settings. Set preset reference active in <i>parameter group 3-1* References</i> . Check for correct wiring. Check scaling of terminals. Check reference signal.
Motor is running in the wrong direction	Motor rotation limit	Check that <i>parameter 4-10 Motor Speed Direction</i> is programmed correctly.	Program correct settings.
	Active reversing signal	Check if a reversing command is programmed for the terminal in <i>parameter group 5-1* Digital inputs</i> .	Deactivate reversing signal.
	Wrong motor phase connection	Change <i>parameter 1-06 Clockwise Direction</i> .	
Motor is not reaching maximum speed	Frequency limits are set incorrectly	Check output limits in <i>parameter 4-14 Motor Speed High Limit [Hz]</i> and <i>parameter 4-19 Max Output Frequency</i> .	Program correct limits.
	Reference input signal not scaled correctly	Check reference input signal scaling in <i>parameter group 6-** Analog I/O mode</i> and <i>parameter group 3-1* References</i> .	Program correct settings.
Motor speed is unstable	Possible incorrect parameter settings	Check the settings of all motor parameters, including all motor compensation settings. For closed-loop operation, check PID settings.	Check settings in <i>parameter group 6-** Analog I/O mode</i> .
Motor runs roughly	Possible overmagnetization	Check for incorrect motor settings in all motor parameters.	Check motor settings in <i>parameter groups 1-2* Motor data, 1-3* Adv motor data, and 1-5* Load indep. setting</i> .
Motor does not brake	Possible incorrect settings in the brake parameters. Possible too short ramp-down times.	Check brake parameters. Check ramp time settings.	Check <i>parameter groups 2-0* DC brake and 3-0* Reference limits</i> .

Symptom	Possible cause	Test	Solution
Open power fuses or circuit breaker trip	Phase-to-phase short	Motor or panel has a short phase-to-phase. Check motor and panel phase for shorts.	Eliminate any shorts detected.
	Motor overload	Motor is overloaded for the application.	Perform the start-up test and verify that motor current is within specifications. If motor current exceeds the nameplate full load current, the motor may run only with reduced load. Review the specifications for the application.
	Loose connections	Perform pre-start-up check for loose connections.	Tighten loose connections.
Mains current imbalance greater than 3%	Problem with mains power (see <i>alarm 4, Mains phase loss</i> description)	Rotate input power leads into the frequency converter 1 position: A to B, B to C, C to A.	If the imbalanced leg follows the wire, it is a power problem. Check mains supply.
	Problem with the frequency converter unit	Rotate input power leads into the frequency converter 1 position: A to B, B to C, C to A.	If the imbalanced leg stays on same input terminal, it is a problem with the unit. Contact the supplier.
Motor current imbalance greater than 3%	Problem with motor or motor wiring	Rotate output motor leads 1 position: U to V, V to W, W to U.	If the imbalanced leg follows the wire, the problem is in the motor or motor wiring. Check motor and motor wiring.
	Problem with the frequency converter unit	Rotate output motor leads 1 position: U to V, V to W, W to U.	If the imbalanced leg stays on same output terminal, it is a problem with the unit. Contact the supplier.
Acoustic noise or vibration (for example a fan blade is making noise or vibrations at certain frequencies)	Resonances, for example, in the motor/fan system	Bypass critical frequencies by using parameters in <i>parameter group 4-6* Speed Bypass</i> .	Check if noise and/or vibration have been reduced to an acceptable limit.
		Turn off overmodulation in <i>parameter 14-03 Overmodulation</i> .	
		Increase resonance damping in <i>parameter 1-64 Resonance Dampening</i> .	

Table 8.3 Troubleshooting

9 Specifications

9.1 Electrical Data

	PK37	PK55	PK75	P1K1	P1K5	P2K2	P3K0
Frequency converter typical shaft output [kW (hp)]	0.37 (0.5)	0.55 (0.75)	0.75 (1.0)	1.1 (1.5)	1.5 (2.0)	2.2 (3.0)	3.0 (4.0)
Enclosure protection rating IP20 (IP21/Type 1 as option)	K1	K1	K1	K1	K1	K1	K2
Output current							
Shaft output [kW]	0.37	0.55	0.75	1.1	1.5	2.2	3
Continuous (3x380–440 V) [A]	1.2	1.7	2.2	3	3.7	5.3	7.2
Continuous (3x441–480 V) [A]	1.1	1.6	2.1	2.8	3.4	4.8	6.3
Intermittent (60 s overload) [A]	1.9	2.7	3.5	4.8	5.9	8.5	11.5
Continuous kVA (400 V AC) [kVA]	0.9	1.2	1.5	2.1	2.6	3.7	5.0
Continuous kVA (480 V AC) [kVA]	0.9	1.3	1.7	2.5	2.8	4.0	5.2
Maximum input current							
Continuous (3x380–440 V) [A]	1.2	1.6	2.1	2.6	3.5	4.7	6.3
Continuous (3x441–480 V) [A]	1.0	1.2	1.8	2.0	2.9	3.9	4.3
Intermittent (60 s overload) [A]	1.9	2.6	3.4	4.2	5.6	7.5	10.1
More specifications							
Maximum cable cross-section (mains, motor, brake, and load sharing) [mm ² (AWG)]	4 (12)						
Estimated power loss at rated maximum load [W] ¹⁾	20.9	25.2	30	40	52.9	74	94.8
Weight, enclosure protection rating IP20 [kg (lb)]	2.3 (5.1)	2.3 (5.1)	2.3 (5.1)	2.3 (5.1)	2.3 (5.1)	2.5 (5.5)	3.6 (7.9)
Weight, enclosure protection rating IP21 [kg (lb)]	4.0 (8.8)	4.0 (8.8)	4.0 (8.8)	4.0 (8.8)	4.0 (8.8)	4.0 (8.8)	5.5 (12.1)
Efficiency [%] ²⁾	96.0	96.6	96.8	97.2	97.0	97.5	98.0

Table 9.1 Mains Supply 3x380–480 V AC

Frequency converter typical shaft output [kW (hp)]	P4K0 4 (5.5)	P5K5 5.5 (7.5)	P7K5 7.5 (10)	P11K 11 (15)	P15K 15 (20)	P18K 18.5 (25)	P22K 22 (30)
Enclosure protection rating IP20 (IP21/Type 1 as option)	K2	K2	K3	K4	K4	K5	K5
Output current							
Shaft output	4	5.5	7.5	11	15	18.5	22
Continuous (3x380–440 V) [A]	9	12	15.5	23	31	37	42.5
Continuous (3x441–480 V) [A]	8.2	11	14	21	27	34	40
Intermittent (60 s overload) [A]	14.4	19.2	24.8	34.5	46.5	55.5	63.8
Continuous kVA (400 V AC) [kVA]	6.2	8.3	10.7	15.9	21.5	25.6	29.5
Continuous kVA (480 V AC) [kVA]	6.8	9.1	11.6	17.5	22.4	28.3	33.3
Maximum input current							
Continuous (3x380–440 V) [A]	8.3	11.2	15.1	22.1	29.9	35.2	41.5
Continuous (3x441–480 V) [A]	6.8	9.4	12.6	18.4	24.7	29.3	34.6
Intermittent (60 s overload) [A]	13.3	17.9	24.2	33.2	44.9	52.8	62.3
More specifications							
Maximum cable cross-section (mains, motor, brake, and load sharing) [mm ² (AWG)]	4 (12)			16 (6)			
Estimated power loss at rated maximum load [W] ¹⁾	115.5	157.5	192.8	289.5	393.4	402.8	467.5
Weight enclosure protection rating IP20 [kg (lb)]	3.6 (7.9)	3.6 (7.9)	4.1 (9.0)	9.4 (20.7)	9.5 (20.9)	12.3 (27.1)	12.5 (27.6)
Weight enclosure protection rating IP21 [kg (lb)]	5.5 (12.1)	5.5 (12.1)	6.5 (14.3)	10.5 (23.1)	10.5 (23.1)	14.0 (30.9)	14.0 (30.9)
Efficiency [%] ²⁾	98.0	97.8	97.7	98.0	98.1	98.0	98.0

Table 9.2 Mains Supply 3x380–480 V AC

Frequency converter typical shaft output [kW (hp)]	PK37 0.37 (0.5)	PK55 0.55 (0.75)	PK75 0.75 (1.0)	P1K1 1.1 (1.5)	P1K5 1.5 (2.0)	P2K2 2.2 (3.0)	P3K7 3.7 (5.0)
Enclosure protection rating IP20 (IP21/Type 1 as option)	K1	K1	K1	K1	K1	K2	K3
Output current							
Continuous (3x200–240 V) [A]	2.2	3.2	4.2	6	6.8	9.6	15.2
Intermittent (60 s overload) [A]	3.5	5.1	6.7	9.6	10.9	15.4	24.3
Continuous kVA (230 V AC) [kVA]	0.9	1.3	1.7	2.4	2.7	3.8	6.1
Maximum input current							
Continuous (3x200–240 V) [A]	1.8	2.7	3.4	4.7	6.3	8.8	14.3
Intermittent (60 s overload) [A]	2.9	4.3	5.4	7.5	10.1	14.1	22.9
More specifications							
Maximum cable cross-section (mains, motor, brake, and load sharing) [mm ² (AWG)]	4 (12)						
Estimated power loss at rated maximum load [W] ¹⁾	29.4	38.5	51.1	60.7	76.1	96.1	147.5
Weight enclosure protection rating IP20 [kg (lb)]	2.3 (5.1)	2.3 (5.1)	2.3 (5.1)	2.3 (5.1)	2.3 (5.1)	2.5 (5.5)	3.6 (7.9)
Weight enclosure protection rating IP21 [kg (lb)]	4.0 (8.8)	4.0 (8.8)	4.0 (8.8)	4.0 (8.8)	4.0 (8.8)	5.5 (12.1)	6.5 (14.3)
Efficiency [%] ²⁾	96.4	96.6	96.3	96.6	96.5	96.7	96.7

Table 9.3 Mains Supply 3x200–240 V AC

Frequency converter typical shaft output [kW (hp)]	PK37 0.37 (0.5)	PK55 0.55 (0.75)	PK75 0.75 (1.0)	P1K1 1.1 (1.5)	P1K5 1.5 (2.0)	P2K2 2.2 (3.0)
Enclosure protection rating IP20 (IP21/Type 1 as option)	K1	K1	K1	K1	K1	K2
Output current						
Continuous (3x200–240 V) [A]	2.2	3.2	4.2	6	6.8	9.6
Intermittent (60 s overload) [A]	3.5	5.1	6.7	9.6	10.9	15.4
Continuous kVA (230 V AC) [kVA]	0.9	1.3	1.7	2.4	2.7	3.8
Maximum input current						
Continuous (1x200–240 V) [A]	2.9	4.4	5.5	7.7	10.4	14.4
Intermittent (60 s overload) [A]	4.6	7.0	8.8	12.3	16.6	23.0
More specifications						
Maximum cable cross-section (mains and motor) [mm ² (AWG)]	4 (12)					
Estimated power loss at rated maximum load [W] ¹⁾	37.7	46.2	56.2	76.8	97.5	121.6
Weight enclosure protection rating IP20 [kg (lb)]	2.3 (5.1)	2.3 (5.1)	2.3 (5.1)	2.3 (5.1)	2.3 (5.1)	2.5 (5.5)
Weight enclosure protection rating IP21 [kg (lb)]	4.0 (8.8)	4.0 (8.8)	4.0 (8.8)	4.0 (8.8)	4.0 (8.8)	5.5 (12.1)
Efficiency [%] ²⁾	94.4	95.1	95.1	95.3	95.0	95.4

Table 9.4 Mains Supply 1x200–240 V AC

1) The typical power loss is at nominal load conditions and expected to be within ±15% (tolerance relates to variety in voltage and cable conditions).

Values are based on a typical motor efficiency (IE2/IE3 border line). Motors with lower efficiency add to the power loss in the frequency converter, and motors with high efficiency reduce power loss.

Applies to dimensioning of frequency converter cooling. If the switching frequency is higher than the default setting, the power losses sometimes rise. LCP and typical control card power consumptions are included. Further options and customer load sometimes add up to 30 W to the losses (though typically only 4 W extra for a fully loaded control card or fieldbus).

For power loss data according to EN 50598-2, refer to www.danfoss.com/vlteneryefficiency.

2) Measured using 50 m (164 ft) shielded motor cables at rated load and rated frequency. For energy efficiency class, see chapter 9.4 Ambient Conditions. For part load losses, see www.danfoss.com/vlteneryefficiency.

9.2 Mains Supply

Mains supply (L1/N, L2/L, L3)

Supply terminals	(L1/N, L2/L, L3)
Supply voltage	380–480 V: -15% (-25%) ¹⁾ to +10%
Supply voltage	200–240 V: -15% (-25%) ¹⁾ to +10%

1) The frequency converter can run at -25% input voltage with reduced performance. The maximum output power of the frequency converter is 75% if input voltage is -25%, and 85% if input voltage is -15%.

Full torque cannot be expected at mains voltage lower than 10% below the lowest rated supply voltage of the frequency converter.

Supply frequency	50/60 Hz ±5%
Maximum imbalance temporary between mains phases	3.0% of rated supply voltage
True power factor (λ)	≥0.9 nominal at rated load
Displacement power factor (cos φ)	Near unity (>0.98)
Switching on input supply (L1/N, L2/L, L3) (power-ups) ≤7.5 kW (10 hp)	Maximum 2 times/minute
Switching on input supply (L1/N, L2/L, L3) (power-ups) 11–22 kW (15–30 hp)	Maximum 1 time/minute

9.3 Motor Output and Motor Data

Motor output (U, V, W)

Output voltage	0–100% of supply voltage
Output frequency	0–500 Hz
Output frequency in VVC ⁺ mode	0–200 Hz

Switching on output	Unlimited
Ramp time	0.01–3600 s
Torque characteristics	
Starting torque (constant torque)	Maximum 160% for 60 s ¹⁾
Overload torque (constant torque)	Maximum 160% for 60 s ¹⁾
Starting current	Maximum 200% for 1 s
Torque rise time in VVC ⁺ mode (independent of f_{sw})	Maximum 50 ms

1) Percentage relates to the nominal torque. It is 150% for 11–22 kW (15–30 hp) frequency converters.

9.4 Ambient Conditions

Ambient conditions

Enclosure protection rating, frequency converter	IP20 (IP21/Type 1 as option)
Enclosure protection rating, conversion kit	IP21/Type 1
Vibration test, all enclosure sizes	1.14 g
Relative humidity	5–95% (IEC 721-3-3; Class 3K3 (non-condensing) during operation)
Ambient temperature (at DPWM switching mode)	
- with derating	Maximum 55 °C (131 °F) ¹⁾²⁾³⁾
- at full constant output current	Maximum 45 °C (113 °F) ⁴⁾
Minimum ambient temperature during full-scale operation	0 °C (32 °F)
Minimum ambient temperature at reduced performance	-10 °C (14 °F)
Temperature during storage/transport	-25 to +65/70 °C (-13 to +149/158 °F)
Maximum altitude above sea level without derating	1000 m (3280 ft)
Maximum altitude above sea level with derating	3000 m (9243 ft)
EMC standards, emission	EN 61800-3, EN 61000-3-2, EN 61000-3-3, EN 61000-3-11, EN 61000-3-12, EN 61000-6-3/4, EN 55011, IEC 61800-3
EMC standards, immunity	EN 61800-3, EN 61000-6-1/2, EN 61000-4-2, EN 61000-4-3 EN 61000-4-4, EN 61000-4-5, EN 61000-4-6, EN 61326-3-1
Energy efficiency class ⁵⁾	IE2

1) Refer to *Special Conditions in the design guide* for:

- Derating for high ambient temperature.
- Derating for high altitude.

2) To prevent control card overtemperature on PROFIBUS, PROFINET, EtherNet/IP, and POWERLINK variants of VLT® Midi Drive FC 280, avoid full digital/analog I/O load at ambient temperature higher than 45 °C (113 °F).

3) Ambient temperature for K1S2 with derating is maximum 50 °C (122 °F).

4) Ambient temperature for K1S2 at full constant output current is maximum 40 °C (104 °F).

5) Determined according to EN 50598-2 at:

- Rated load.
- 90% rated frequency.
- Switching frequency factory setting.
- Switching pattern factory setting.
- Open type: Surrounding air temperature 45 °C (113 °F).
- Type 1 (NEMA kit): Ambient temperature 45 °C (113 °F).

9.5 Cable Specifications

Cable lengths and cross-sections¹⁾

Maximum motor cable length, shielded	50 m (164 ft)
Maximum motor cable length, unshielded	75 m (246 ft)
Maximum cross-section of control terminals, flexible/rigid wire	2.5 mm ² /14 AWG

Minimum cross-section of control terminals	0.55 mm ² /30 AWG
Maximum STO input cable length, unshielded	20 m (66 ft)

1) For power cables cross-sections, see Table 9.1, Table 9.2, Table 9.3 and Table 9.4.

When complying with EN 55011 1A and EN 55011 1B, the motor cable must in certain instances be reduced. See chapter 2.6.2

EMC Emission in the VLT[®] Midi Drive FC 280 Design Guide for more details.

9.6 Control Input/Output and Control Data

Digital inputs

Terminal number	18, 19, 27 ¹⁾ , 29, 32, 33
Logic	PNP or NPN
Voltage level	0–24 V DC
Voltage level, logic 0 PNP	<5 V DC
Voltage level, logic 1 PNP	>10 V DC
Voltage level, logic 0 NPN	>19 V DC
Voltage level, logic 1 NPN	<14 V DC
Maximum voltage on input	28 V DC
Pulse frequency range	4–32 kHz
(Duty cycle) minimum pulse width	4.5 ms
Input resistance, R _i	Approximately 4 kΩ

1) Terminal 27 can also be programmed as output.

STO inputs¹⁾

Terminal number	37, 38
Voltage level	0–30 V DC
Voltage level, low	<1.8 V DC
Voltage level, high	>20 V DC
Maximum voltage on input	30 V DC
Minimum input current (each pin)	6 mA

1) Refer to chapter 6 Safe Torque Off (STO) for more details about STO inputs.

Analog inputs

Number of analog inputs	2
Terminal number	53 ¹⁾ , 54
Modes	Voltage or current
Mode select	Software
Voltage level	0–10 V
Input resistance, R _i	Approximately 10 kΩ
Maximum voltage	-15 V to +20 V
Current level	0/4 to 20 mA (scaleable)
Input resistance, R _i	Approximately 200 Ω
Maximum current	30 mA
Resolution for analog inputs	11 bit
Accuracy of analog inputs	Maximum error 0.5% of full scale
Bandwidth	100 Hz

The analog inputs are galvanically isolated from the supply voltage (PELV) and other high-voltage terminals.

1) Terminal 53 supports only voltage mode and can also be used as digital input.

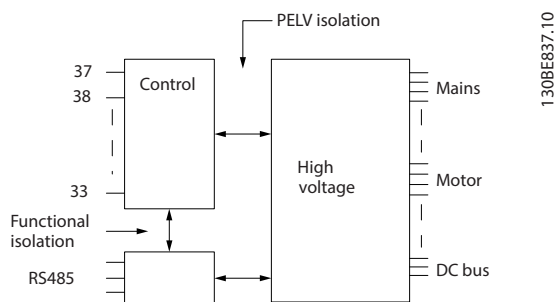

Illustration 9.1 Galvanic Isolation

NOTICE

HIGH ALTITUDE

For installation at altitudes above 2000 m (6562 ft), contact Danfoss hotline regarding PELV.

Pulse inputs

Programmable pulse inputs	2
Terminal number pulse	29, 33
Maximum frequency at terminal 29, 33	32 kHz (push-pull driven)
Maximum frequency at terminal 29, 33	5 kHz (open collector)
Minimum frequency at terminal 29, 33	4 Hz
Voltage level	See the section on digital input
Maximum voltage on input	28 V DC
Input resistance, R_i	Approximately 4 k Ω
Pulse input accuracy	Maximum error: 0.1% of full scale

Digital outputs

Programmable digital/pulse outputs	2
Terminal number	27 ¹⁾
Voltage level at digital/frequency output	0–24 V
Maximum output current (sink or source)	40 mA
Maximum load at frequency output	1 k Ω
Maximum capacitive load at frequency output	10 nF
Minimum output frequency at frequency output	4 Hz
Maximum output frequency at frequency output	32 kHz
Accuracy of frequency output	Maximum error: 0.1% of full scale
Resolution of frequency output	10 bit
Terminal number (see data in analog outputs)	42 ²⁾
Voltage level at digital output	0–17 V

1) Terminal 27 can also be programmed as input.

2) Terminal 42 can also be programmed as analog output.

The digital output is galvanically isolated from the supply voltage (PELV) and other high-voltage terminals.

Analog outputs

Number of programmable analog outputs	1
Terminal number	42 ¹⁾
Current range at analog output	0/4–20 mA
Maximum resistor load to common at analog output	500 Ω
Maximum voltage at analog output	17 V
Accuracy on analog output	Maximum error: 0.8% of full scale
Resolution on analog output	10 bit

1) Terminal 42 can also be programmed as digital output.

The analog output is galvanically isolated from the supply voltage (PELV) and other high-voltage terminals.

Control card, 24 V DC output

Terminal number	12, 13
Maximum load	100 mA

The 24 V DC supply is galvanically isolated from the supply voltage (PELV). However, the supply has the same potential as the analog and digital inputs and outputs.

Control card, +10 V DC output

Terminal number	50
Output voltage	10.5 V \pm 0.5 V
Maximum load	15 mA

The 10 V DC supply is galvanically isolated from the supply voltage (PELV) and other high-voltage terminals.

Control card, RS485 serial communication

Terminal number	68 (P, TX+, RX+), 69 (N, TX-, RX-)
Terminal number 61	Common for terminals 68 and 69

The RS485 serial communication circuit is galvanically isolated from the supply voltage (PELV).

Control card, USB serial communication

USB standard	1.1 (full speed)
USB plug	USB type B plug

Connection to PC is carried out via a standard host/device USB cable.

The USB connection is galvanically isolated from the supply voltage (PELV) and other high-voltage terminals.

The USB ground connection is not galvanically isolated from protective earth. Use only an isolated laptop as PC connection to the USB connector on the frequency converter.

Relay outputs

Programmable relay outputs	1
Relay 01	01–03 (NC), 01–02 (NO)
Maximum terminal load (AC-1) ¹⁾ on 01–02 (NO) (resistive load)	250 V AC, 3 A
Maximum terminal load (AC-15) ¹⁾ on 01–02 (NO) (inductive load @ $\cos\phi$ 0.4)	250 V AC, 0.2 A
Maximum terminal load (DC-1) ¹⁾ on 01–02 (NO) (resistive load)	30 V DC, 2 A
Maximum terminal load (DC-13) ¹⁾ on 01–02 (NO) (inductive load)	24 V DC, 0.1 A
Maximum terminal load (AC-1) ¹⁾ on 01–03 (NC) (resistive load)	250 V AC, 3 A
Maximum terminal load (AC-15) ¹⁾ on 01–03 (NC) (inductive load @ $\cos\phi$ 0.4)	250 V AC, 0.2 A
Maximum terminal load (DC-1) ¹⁾ on 01–03 (NC) (resistive load)	30 V DC, 2 A
Minimum terminal load on 01–03 (NC), 01–02 (NO)	24 V DC 10 mA, 24 V AC 20 mA

1) IEC 60947 parts 4 and 5.

The relay contacts are galvanically isolated from the rest of the circuit by reinforced isolation.

Control card performance

Scan interval	1 ms
---------------	------

Control characteristics

Resolution of output frequency at 0–500 Hz	\pm 0.003 Hz
System response time (terminals 18, 19, 27, 29, 32, and 33)	\leq 2 ms
Speed control range (open loop)	1:100 of synchronous speed
Speed accuracy (open loop)	\pm 0.5% of nominal speed
Speed accuracy (closed loop)	\pm 0.1% of nominal speed

All control characteristics are based on a 4-pole asynchronous motor.

9.7 Connection Tightening Torques

Make sure to use the right torques when tightening all electrical connections. Too low or too high torque sometimes causes electrical connection problems. To ensure that correct torques are applied, use a torque wrench. Recommended slot screwdriver type is SZS 0.6x3.5 mm.

Enclosure type	Power [kW (hp)]	Torque [Nm (in-lb)]						
		Mains	Motor	DC connection	Brake	Ground	Control	Relay
K1	0.37–2.2 (0.5–3.0)	0.8 (7.1)	0.8 (7.1)	0.8 (7.1)	0.8 (7.1)	1.6 (14.2)	0.4 (3.5)	0.5 (4.4)
K2	3.0–5.5 (4.0–7.5)	0.8 (7.1)	0.8 (7.1)	0.8 (7.1)	0.8 (7.1)	1.6 (14.2)	0.4 (3.5)	0.5 (4.4)
K3	7.5 (10)	0.8 (7.1)	0.8 (7.1)	0.8 (7.1)	0.8 (7.1)	1.6 (14.2)	0.4 (3.5)	0.5 (4.4)
K4	11–15 (15–20)	1.2 (10.6)	1.2 (10.6)	1.2 (10.6)	1.2 (10.6)	1.6 (14.2)	0.4 (3.5)	0.5 (4.4)
K5	18.5–22 (25–30)	1.2 (10.6)	1.2 (10.6)	1.2 (10.6)	1.2 (10.6)	1.6 (14.2)	0.4 (3.5)	0.5 (4.4)

Table 9.5 Tightening Torques

9.8 Fuses and Circuit Breakers

Use fuses and/or circuit breakers on the supply side to protect service personnel and equipment from injuries and damage if there is component breakdown inside the frequency converter (first fault).

Branch circuit protection

Protect all branch circuits in an installation (including switch gear and machines) against short circuit and overcurrent according to national/international regulations.

NOTICE

Integral solid-state short-circuit protection does not provide branch circuit protection. Provide branch circuit protection in accordance with the national and local rules and regulations.

Table 9.6 lists the recommended fuses and circuit breakers that have been tested.

CAUTION

PERSONAL INJURY AND EQUIPMENT DAMAGE RISK

Malfunction or failing to follow the recommendations may result in personal risk and damage to the frequency converter and other equipment.

- Select fuses according to recommendations. Possible damage can be limited to be inside the frequency converter.

NOTICE

EQUIPMENT DAMAGE

Using fuses and/or circuit breakers is mandatory to ensure compliance with IEC 60364 for CE. Failure to follow the protection recommendations can result in damage to the frequency converter.

Danfoss recommends using the fuses and circuit breakers in Table 9.6 and Table 9.7 to ensure compliance with UL 508C or IEC 61800-5-1. For non-UL applications, design circuit breakers for protection in a circuit capable of delivering a maximum of 50000 A_{rms} (symmetrical), 240 V/400 V maximum. The frequency converter short-circuit current rating (SCCR) is suitable for use on a circuit capable of delivering not more than 100000 A_{rms}, 240 V/480 V maximum when protected by Class T fuses.

Enclosure size		Power [kW (hp)]	Non-UL fuse	Non-UL circuit breaker (Eaton)
3-phase 380–480 V	K1	0.37 (0.5)	gG-10	PKZM0-16
		0.55–0.75 (0.75–1.0)		
		1.1–1.5 (1.5–2.0)	gG-20	
		2.2 (3.0)		
	K2	3.0–5.5 (4.0–7.5)	gG-25	PKZM0-20
	K3	7.5 (10)		PKZM0-25
	K4	11–15 (15–20)	gG-50	–
	K5	18.5–22 (25–30)	gG-80	–
3-phase 200–240 V	K1	0.37 (0.5)	gG-10	PKZM0-16
		0.55 (0.75)	gG-20	
		0.75 (1.0)		
		1.1 (1.5)		
		1.5 (2.0)		
	K2	2.2 (3.0)	gG-25	PKZM0-20
	K3	3.7 (5.0)		PKZM0-25
Single-phase 200–240 V	K1	0.37 (0.5)	gG-10	PKZM0-16
		0.55 (0.75)	gG-20	
		0.75 (1.0)		
		1.1 (1.5)		
		1.5 (2.0)		
	K2	2.2 (3.0)	gG-25	PKZM0-20

Table 9.6 Non-UL Fuse and Circuit Breaker

Enclosure size		Power [kW (hp)]	Bussmann E4273						Littelfuse E81895	MERSEN E163267/ E2137	MERSEN E163267/ E2138
			Class RK1	Class J	Class T	Class CC	Class CC	Class CC			
3-phase 380–480 V	K1	0.37–0.75 (0.5–1.0)	KTS-R-6	JKS-6	JJS-6	FNQ-R-6	KTK-R-6	LP-CC-6	KLSR-6	ATM-R6	A6K-6R
		1.1–1.5 (1.5–2.0)	KTS-R-10	JKS-10	JJS-10	FNQ-R-10	KTK-R-10	LP-CC-10	KLSR-10	ATM-R10	A6K-10R
		2.2 (3.0)	KTS-R-15	JKS-15	JJS-15	FNQ-R-15	KTK-R-15	LP-CC-15	KLSR-15	ATM-R15	A6K-15R
	K2–K3	3.0–7.5 (4.0–10)	KTS-R-25	JKS-25	JJS-25	FNQ-R-25	KTK-R-25	LP-CC-25	KLSR-25	ATM-R25	A6K-25R
	K4	11–15 (15–20)	KTS-R-50	JKS-50	JJS-50	–	–	–	KLSR-50	–	A6K-50R
	K5	18.5–22 (25–30)	–	JKS-80	JJS-80	–	–	–	–	–	–
3-phase 200–240 V	K1	0.37 (0.5)	KTN-R-6	JKS-6	JJN-6	FNQ-R-6	KTK-R-6	LP-CC-6	KLNR-6	ATM-R6	A2K-6R
		0.55 (0.75)	KTN-R-10	JKS-10	JJN-10	FNQ-R-10	KTK-R-10	LP-CC-10	KLNR-10	ATM-R10	A2K-10R
		0.75 (1.0)	KTN-R-15	JKS-15	JJN-15	FNQ-R-15	KTK-R-15	LP-CC-15	KLNR-15	ATM-R15	A2K-15R
		1.1–1.5 (1.5–2.0)	KTN-R-20	JKS-20	JJN-20	FNQ-R-20	KTK-R-20	LP-CC-20	KLNR-20	ATM-R20	A2K-20R
	K2–K3	2.2–3.7 (3.0–5.0)	KTN-R-25	JKS-25	JJN-25	–	–	–	KLNR-25	ATM-R25	A2K-25R
Single-phase 200–240 V	K1	0.37 (0.5)	KTN-R-6	JKS-6	JJN-6	FNQ-R-6	KTK-R-6	LP-CC-6	KLNR-6	ATM-R6	A2K-6R
		0.55 (0.75)	KTN-R-10	JKS-10	JJN-10	FNQ-R-10	KTK-R-10	LP-CC-10	KLNR-10	ATM-R10	A2K-10R
		0.75 (1.0)	KTN-R-15	JKS-15	JJN-15	FNQ-R-15	KTK-R-15	LP-CC-15	KLNR-15	ATM-R15	A2K-15R
		1.1–1.5 (1.5–2.0)	KTN-R-20	JKS-20	JJN-20	FNQ-R-20	KTK-R-20	LP-CC-20	KLNR-20	ATM-R20	A2K-20R
	K2	2.2 (3.0)	KTN-R-25	JKS-25	JJN-25	–	–	–	KLNR-25	ATM-R25	A2K-25R

Table 9.7 UL fuse

9.9 Enclosure Sizes, Power Ratings, and Dimensions

	Enclosure size	K1					K2			K3	K4		K5		
		0.37 (0.5)	0.55 (0.75)	0.75 (1.0)	1.1 (1.5)	1.5 (2.0)	2.2 (3.0)	3 (4.0)	4 (5.5)	5.5 (7.5)	7.5 (10)	11 (15)	15 (20)	18.5 (25)	22 (30)
Power size [kW (hp)]	Single-phase 200–240 V	0.37 (0.5)	0.55 (0.75)	0.75 (1.0)	1.1 (1.5)	1.5 (2.0)	2.2 (3.0)			-	-	-			
	3-phase 200–240 V	0.37 (0.5)	0.55 (0.75)	0.75 (1.0)	1.1 (1.5)	1.5 (2.0)	2.2 (3.0)			3.7 (5.0)	-		-		
	3-phase 380–480 V	0.37 (0.5)	0.55 (0.75)	0.75 (1.0)	1.1 (1.5)	1.5 (2.0)	2.2 (3.0)	3 (4.0)	4 (5.5)	5.5 (7.5)	7.5 (10)	11 (15)	15 (20)	18.5 (25)	22 (30)
Dimensions [mm (in)]	FC 280 IP20														
	Height A1	210 (8.3)					272.5 (10.7)			272.5 (10.7)	317.5 (12.5)	410 (16.1)			
	Height A2	278 (10.9)					340 (13.4)			341.5 (13.4)	379.5 (14.9)	474 (18.7)			
	Width B	75 (3.0)					90 (3.5)			115 (4.5)	133 (5.2)	150 (5.9)			
	Depth C	168 (6.6)					168 (6.6)			168 (6.6)	245 (9.6)	245 (9.6)			
	FC 280 with IP21/UL/Type 1 kit														
	Height A	338.5 (13.3)					395 (15.6)			395 (15.6)	425 (16.7)	520 (20.5)			
	Width B	100 (3.9)					115 (4.5)			130 (5.1)	153 (6.0)	170 (6.7)			
	Depth C	183 (7.2)					183 (7.2)			183 (7.2)	260 (10.2)	260 (10.2)			
	FC 280 with bottom cable entry cover (w/o top cover)														
	Height A	294 (11.6)					356 (14)			357 (14.1)	391 (15.4)	486 (19.1)			
Width B	75 (3.0)					90 (3.5)			115 (4.5)	133 (5.2)	150 (5.9)				
Depth C	168 (6.6)					168 (6.6)			168 (6.6)	245 (9.6)	245 (9.6)				
Weight [kg (lb)]	IP20	2.5 (5.5)					3.6 (7.9)			4.6 (10.1)	8.2 (18.1)	11.5 (25.4)			
	IP21	4.0 (8.8)					5.5 (12.1)			6.5 (14.3)	10.5 (23.1)	14.0 (30.9)			
Mounting holes [mm (in)]	a	198 (7.8)					260 (10.2)			260 (10.2)	297.5 (11.7)	390 (15.4)			
	b	60 (2.4)					70 (2.8)			90 (3.5)	105 (4.1)	120 (4.7)			
	c	5 (0.2)					6.4 (0.25)			6.5 (0.26)	8 (0.32)	7.8 (0.31)			
	d	9 (0.35)					11 (0.43)			11 (0.43)	12.4 (0.49)	12.6 (0.5)			
	e	4.5 (0.18)					5.5 (0.22)			5.5 (0.22)	6.8 (0.27)	7 (0.28)			
	f	7.3 (0.29)					8.1 (0.32)			9.2 (0.36)	11 (0.43)	11.2 (0.44)			

Table 9.8 Enclosure Sizes, Power Ratings, and Dimensions

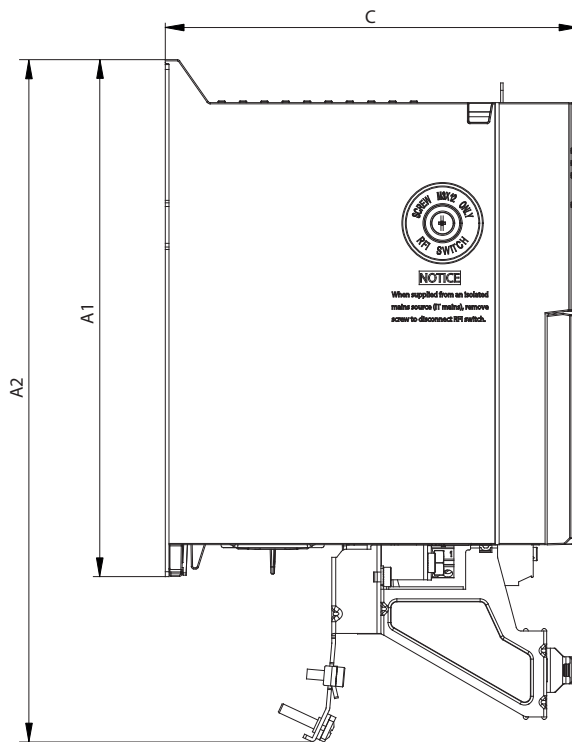
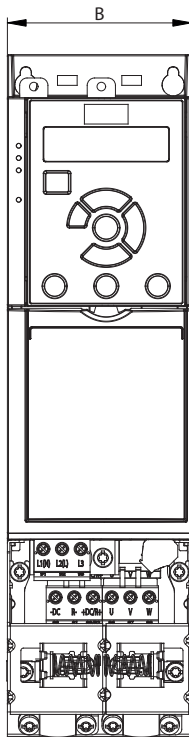

130BE84.11

9

Illustration 9.2 Standard with Decoupling Plate

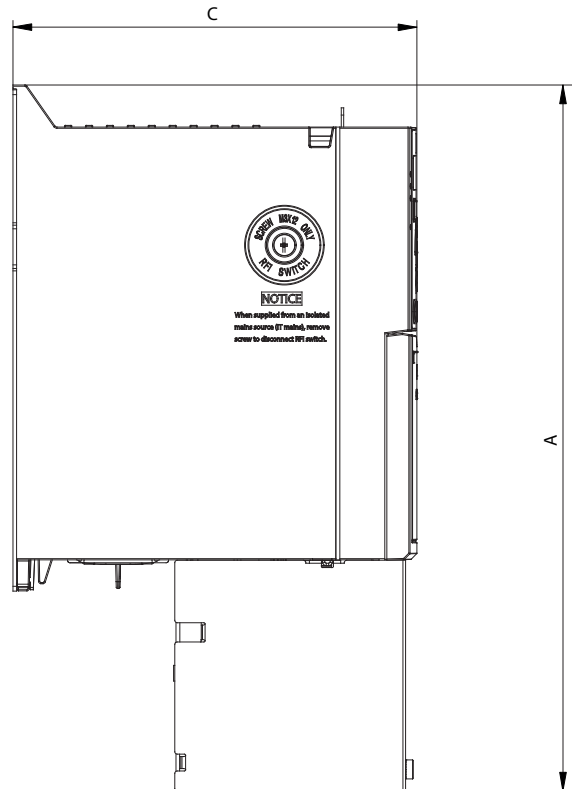
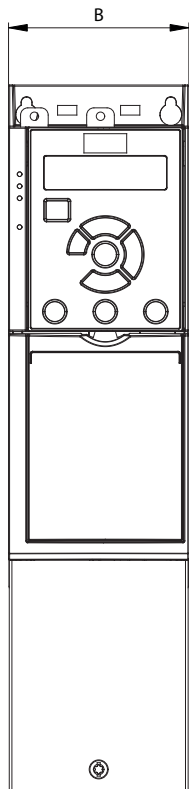

130BE846.10

Illustration 9.3 Standard with Bottom Cable Entry Cover (w/o Top Cover)

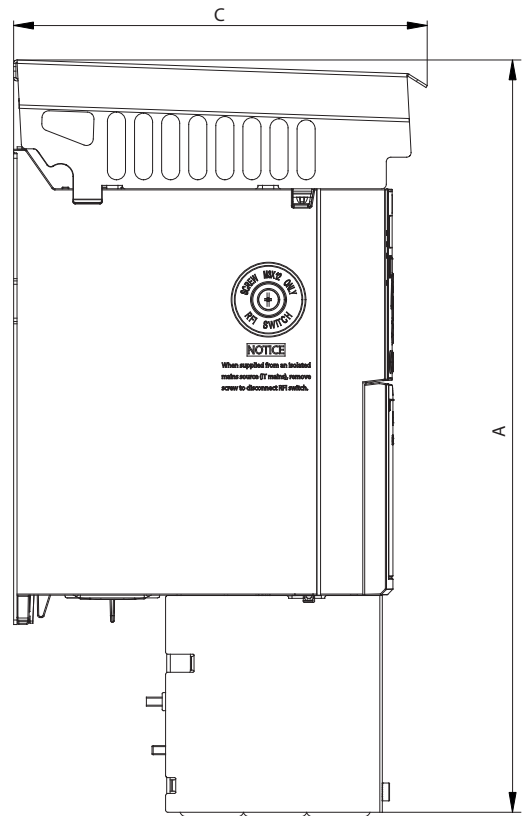
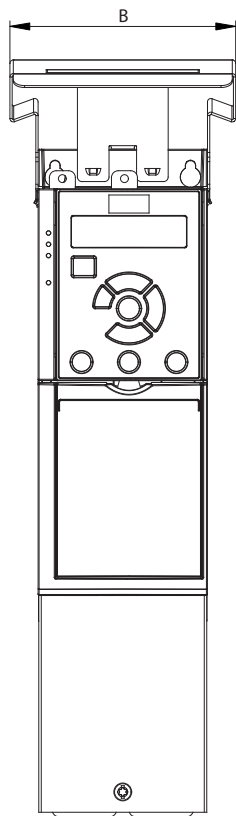

1308E845.10

Illustration 9.4 Standard with IP21/UL/Type 1 kit

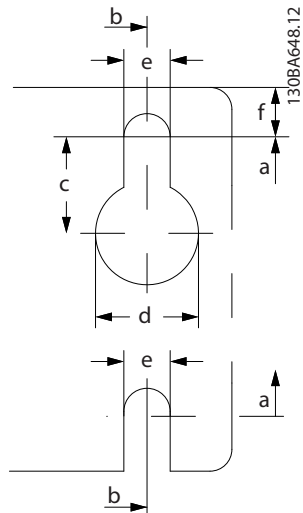
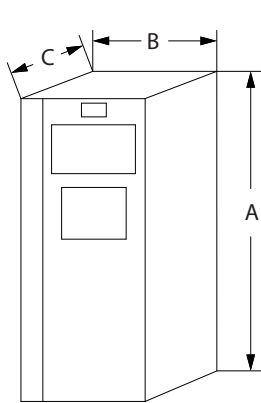

Illustration 9.5 Top and Bottom Mounting Holes

10 Appendix

10.1 Symbols, Abbreviations, and Conventions

°C	Degrees celsius
°F	Degrees fahrenheit
AC	Alternating current
AEO	Automatic energy optimization
AWG	American wire gauge
AMA	Automatic motor adaptation
DC	Direct current
EMC	Electromagnetic compatibility
ETR	Electronic thermal relay
$f_{M,N}$	Nominal motor frequency
FC	Frequency converter
I_{INV}	Rated inverter output current
I_{LIM}	Current limit
$I_{M,N}$	Nominal motor current
$I_{VLT,MAX}$	Maximum output current
$I_{VLT,N}$	Rated output current supplied by the frequency converter
IP	Ingress protection
LCP	Local control panel
MCT	Motion control tool
MM	Memory module
MMP	Memory module programmer
n_s	Synchronous motor speed
$P_{M,N}$	Nominal motor power
PELV	Protective extra low voltage
PCB	Printed circuit board
PM Motor	Permanent magnet motor
PUD	Power unit data
PWM	Pulse width modulation
RPM	Revolutions per minute
SIVP	Specific initialization values and protection
STO	Safe Torque Off
T_{LIM}	Torque limit
$U_{M,N}$	Nominal motor voltage

Table 10.1 Symbols and Abbreviations

Conventions

- For illustrations, all dimensions are in [mm (in)].
- An asterisk (*) indicates the default setting of a parameter.
- Numbered lists indicate procedures.
- Bullet lists indicate other information.
- Italicized text indicates:
 - Cross-reference.
 - Link.
 - Parameter name.

10.2 Parameter Menu Structure

0-0**	Operation / Display	0-30	Custom Readout Unit	[0]	Disabled
0-0*	Basic Settings	0-30	None	[0]	Disabled
0-01	Language	[0]	None	*[1]	Enabled
*[0]	English	*[1]	%	0-44	[Off/Reset] Key on LCP
[1]	Deutsch	[5]	PPM	[0]	Disabled
[2]	Francais	[10]	1/min	*[1]	Enabled
[3]	Dansk	[11]	RPM	[7]	Enable Reset Only
[4]	Spanish	[12]	Pulse/s	0-5*	Copy/Save
[5]	Italiano	[20]	l/s	0-50	LCP Copy
[28]	Brasport	[21]	l/min	*[0]	No copy
0-02	Motor Speed Unit	[22]	l/h	[1]	All to LCP
[0]	RPM	[23]	m ³ /s	[2]	All from LCP
*[1]	Hz	[24]	m ³ /min	[3]	Size indep. from LCP
0-03	Regional Settings	[25]	kg/h	0-51	Set-up Copy
[0]	International	[30]	kg/min	*[0]	No copy
[1]	North America	[31]	kg/t/min	[1]	Copy from setup 1
0-04	Operating State at Power-up	[32]	kg/h	[2]	Copy from setup 2
[0]	Resume	[33]	t/min	[3]	Copy from setup 3
*[1]	Forced stop, ref=old	[34]	t/h	[4]	Copy from setup 4
[2]	Forced stop, ref=0	[40]	m/s	[9]	Copy from Factory setup
0-06	GridType	[41]	m/min	0-6*	Password
[0]	200-240V/50Hz/IT-grid	[45]	m	0-60	Main Menu Password
[1]	200-240V/50Hz/Delta	[60]	°C	0 - 999 °0	
[2]	200-240V/50Hz	[70]	mbar		
[10]	380-440V/50Hz/IT-grid	[71]	bar		
[11]	380-440V/50Hz/Delta	[72]	Pa		
[12]	380-440V/50Hz	[73]	kPa		
[20]	440-480V/50Hz/IT-grid	[74]	m WG		
[21]	440-480V/50Hz/Delta	[80]	kW		
[22]	440-480V/50Hz	[120]	GPM		
[100]	200-240V/60Hz/IT-grid	[121]	gal/s		
[101]	200-240V/60Hz/Delta	[122]	gal/min		
[102]	200-240V/60Hz	[123]	gal/h		
[110]	380-440V/60Hz/IT-grid	[124]	CFM		
[111]	380-440V/60Hz/Delta	[127]	ft ³ /h		
[112]	380-440V/60Hz	[140]	ft ³ /min		
[120]	440-480V/60Hz/IT-grid	[141]	°F		
[121]	440-480V/60Hz/Delta	[160]	psi		
[122]	440-480V/60Hz	[171]	lb/in2		
0-07	Auto DC Braking	[172]	ft WG		
[0]	Off	[173]	ft WG		
*[1]	On	[180]	HP		
0-1*	Set-up Operations	0-31	Custom Readout Min Value		
0-10	Active Set-up	0 - 999999,99	CustomReadoutUnit*0		
*[1]	Set-up 1	0-32	CustomReadoutUnit		
[2]	Set-up 2	0-32	Custom Readout Max Value		
[3]	Set-up 3	0-37	0.0 - 999999,99 CustomReadoutUnit		
[4]	Set-up 4	0-37	*100 CustomReadoutUnit		
[9]	Multi Set-up	0-37	Display Text 1		
0-11	Programming Set-up	0-38	0 - 0 *		
[1]	Set-up 1	0-38	Display Text 2		
[2]	Set-up 2	0 - 0 *	0 - 0 *		
[3]	Set-up 3	0-39	Display Text 3		
[4]	Set-up 4	0 - 0 *	0 - 0 *		
[9]	Active Set-up	0-4	LCP keypad		
0-12	Link Setups	0-40	[Hand on] Key on LCP		
[0]	Not linked	[0]	Disabled		
*[20]	Linked	*[1]	Enabled		
0-14	Readout: Edit Set-ups / Channel	0-42	[Auto on] Key on LCP		
[1666]	Digital Output	[1666]	Digital Output		
[1667]	Pulse input 29 [Hz]	[1667]	Pulse input 29 [Hz]		
[1668]	Pulse input 33 [Hz]	[1668]	Pulse input 33 [Hz]		
[1669]	Relay output 27 [Hz]	[1669]	Relay output 27 [Hz]		
[1671]	Relay output	[1671]	Relay output		
[1672]	Counter A	[1672]	Counter A		
[1673]	Counter B	[1673]	Counter B		
[1674]	Prec. Stop. Counter	[1674]	Prec. Stop. Counter		
[1680]	Fieldbus CTW. 1	[1680]	Fieldbus CTW. 1		
[1682]	Fieldbus REF. 1	[1682]	Fieldbus REF. 1		
[1684]	Comm. Option STW	[1684]	Comm. Option STW		
[1685]	FC Port CTW. 1	[1685]	FC Port CTW. 1		
[1686]	FC Port REF. 1	[1686]	FC Port REF. 1		
[1690]	Alarm Word	[1690]	Alarm Word		
[1691]	Alarm Word 2	[1691]	Alarm Word 2		
[1692]	Warning Word	[1692]	Warning Word		
[1693]	Warning Word 2	[1693]	Warning Word 2		
[1694]	Ext. Status Word	[1694]	Ext. Status Word		
[1695]	Ext. Status Word 2	[1695]	Ext. Status Word 2		
[1697]	Alarm Word 3	[1697]	Alarm Word 3		
[1698]	Warning Word 3	[1698]	Warning Word 3		
[1890]	Process PID Error	[1890]	Process PID Error		
[1891]	Process PID Output	[1891]	Process PID Output		
[1892]	Process PID Clamped Output	[1892]	Process PID Clamped Output		
[1893]	Process PID Gain Scaled Output	[1893]	Process PID Gain Scaled Output		
[2117]	Ext. 1 Reference [Unit]	[2117]	Ext. 1 Reference [Unit]		
[2118]	Ext. 1 Feedback [Unit]	[2118]	Ext. 1 Feedback [Unit]		
[2119]	Ext. 1 Output [%]	[2119]	Ext. 1 Output [%]		
[3401]	PCD 1 Write For Application	[3401]	PCD 1 Write For Application		
[3402]	PCD 2 Write For Application	[3402]	PCD 2 Write For Application		
[3403]	PCD 3 Write For Application	[3403]	PCD 3 Write For Application		
[3404]	PCD 4 Write For Application	[3404]	PCD 4 Write For Application		
[3405]	PCD 5 Write For Application	[3405]	PCD 5 Write For Application		
[3406]	PCD 6 Write For Application	[3406]	PCD 6 Write For Application		
[3407]	PCD 7 Write For Application	[3407]	PCD 7 Write For Application		
[3408]	PCD 8 Write For Application	[3408]	PCD 8 Write For Application		
[3409]	PCD 9 Write For Application	[3409]	PCD 9 Write For Application		
[3410]	PCD 10 Write For Application	[3410]	PCD 10 Write For Application		
[3421]	PCD 1 Read For Application	[3421]	PCD 1 Read For Application		
[3422]	PCD 2 Read For Application	[3422]	PCD 2 Read For Application		
[3423]	PCD 3 Read For Application	[3423]	PCD 3 Read For Application		
[3424]	PCD 4 Read For Application	[3424]	PCD 4 Read For Application		
[3425]	PCD 5 Read For Application	[3425]	PCD 5 Read For Application		
[3426]	PCD 6 Read For Application	[3426]	PCD 6 Read For Application		
[3427]	PCD 7 Read For Application	[3427]	PCD 7 Read For Application		
[3428]	PCD 8 Read For Application	[3428]	PCD 8 Read For Application		
[3429]	PCD 9 Read For Application	[3429]	PCD 9 Read For Application		
[3430]	PCD 10 Read For Application	[3430]	PCD 10 Read For Application		
[3450]	Actual Position	[3450]	Actual Position		
[3456]	Track Error	[3456]	Track Error		
0-21	Display Line 1.2 Small	0-21	Display Line 1.2 Small		
0-22	Same choices with 0-20	0-22	Same choices with 0-20		
0-23	Display Line 1.3 Small	0-23	Display Line 1.3 Small		
0-24	Same choices with 0-20	0-24	Same choices with 0-20		
0-3*	LCP Custom Readout	0-3*	LCP Custom Readout		

Parameter ID	Description	Units	Factory Default	Adjustable Range	Notes
1-2*	Motor Data	0.001 - 1 s *Size related			
1-20	Motor Power	m WG	[74]		
[2]	0.12 kW - 0.16 hp	kW	[80]		
[3]	0.18 kW - 0.25 hp	GPM	[120]		
[4]	0.25 kW - 0.33 hp	gal/s	[121]		
[5]	0.37 kW - 0.5 hp	gal/min	[122]		
[6]	0.55 kW - 0.75 hp	gal/h	[123]		
[7]	0.75 kW - 1 hp	CFM	[124]		
[8]	1.1 kW - 1.5 hp	ft ³ /min	[125]		
[9]	1.5 kW - 2 hp	ft ³ /h	[126]		
[10]	2.2 kW - 3 hp	lb/min	[127]		
[11]	3 kW - 4 hp	lb/h	[130]		
[12]	3.7 kW - 5 hp	lb/in ²	[131]		
[13]	4 kW - 5.4 hp	in WG	[132]		
[14]	5.5 kW - 7.5 hp	ft/min	[141]		
[15]	7.5 kW - 10 hp	ft	[145]		
[16]	11 kW - 15 hp	lb ft	[150]		
[17]	15 kW - 20 hp	°F	[160]		
[18]	18.5 kW - 25 hp	psi	[170]		
[19]	22 kW - 30 hp	lb/in ²	[171]		
[20]	30 kW - 40 hp	in WG	[172]		
1-22	Motor Voltage	ft WG	[173]		
50 - 1000 V *Size related		HP	[180]		
1-23	Motor Frequency	Minimum Reference	3-02		
20 - 500 Hz *Size related		-4999.0 - 4999 ReferenceFeedbackUnit			
1-24	Motor Current	Maximum Reference	3-03		
0.01 - 1000.0 A *Size related		-4999.0 - 4999 ReferenceFeedbackUnit			
1-25	Motor Nominal Speed	*Size related			
50 - 6000 RPM *Size related		Reference Range			
1-26	Motor Cont. Rated Torque	Reference Function	3-04		
0.1 - 1000.0 Nm *Size related		Sum	[1]		
1-29	Automatic Motor Adaption (AMA)	External/Preset	[1]		
[0]	Off	References	3-1*		
[1]	Enable Complete AMA	Preset Reference	3-10		
[2]	Enable Reduced AMA	-100 - 100 % *0 %			
1-3*	Adv. Motor Data I	Jog Speed [Hz]	3-11		
1-30	Stator Resistance (Rs)	0 - 500.0 Hz *5 Hz			
0.0 - 9999.000 Ohm *Size related		Catch up/slow Down Value	3-12		
Rotor Resistance (Rr)		0 - 100 % *0 %			
0 - 9999.000 Ohm *Size related		Preset Relative Reference	3-14		
Stator Leakage Reactance (X1)		Reference 1 Source	3-15		
0.0 - 9999.000 Ohm *Size related		No function	[0]		
Main Reactance (Xh)		Analog Input 53	[1]		
0.0 - 9999.000 Ohm *Size related		Analog Input 54	[2]		
d-axis Inductance (Ld)		Frequency input 29	[7]		
q-axis Inductance (Lq)		Frequency input 33	[8]		
0.000 - 65535 mH *Size related		Local bus reference	[11]		
Motor Poles		Digital pot.meter	[20]		
2 - 100 *Size related		Bus PCD	[32]		
Adv. Motor Data II		Reference 2 Source	3-16		
Back EMF at 1000 RPM		Same choices with 3-15			
1 - 9000 V *Size related		Reference 3 Source	3-17		
Motor Cable Length		Same choices with 3-15			
0 - 100 m *50 m		Relative Scaling Reference Resource	3-18		
Motor Cable Length Feet		No function	[0]		
0 - 328 ft *164 ft		Analog Input 53	[1]		
d-axis Inductance Sat. (LdSat)		Analog Input 54	[2]		
0.001 - 1 s *Size related		Frequency input 29	[7]		
0 - 10 s *5 s					
1-8*	Stop Adjustments				
1-80	Function at Stop	Brake Resistor (ohm)	2-11		
[0]	Coast	0 - 6200 Ohm *Size related			
[1]	DC hold / Motor Preheat	Brake Power Limit (kW)	2-12		
[3]	Pre-magnetizing	0.001 - 2000 kW *Size related			
1-82	Min Speed for Function at Stop [Hz]	Brake voltage reduce	2-14		
0 - 20 Hz *0 Hz		0 - 500 V *0 V			
1-83	Precise Stop Function	AC Brake, Max current	2-16		
[0]	Precise ramp stop	0 - 160 % *100 %			
[1]	Counter stop with reset	Over-voltage Control	2-17		
[2]	Counter stop without reset	Disabled	[*0]		
[3]	Speed compensated stop	Enabled (not at stop)	[1]		
[4]	Speed compensated counter stop with reset	Enabled	[2]		
[5]	Speed compensated counter stop without reset	Over-voltage Gain	2-19		
1-84	Precise Stop Counter Value	0 - 200 % *100 %			
0 - 99999999 *1000000		Mechanical Brake	2-2*		
1-85	Precise Stop Compensation Delay	Release Brake Current	2-20		
0 - 100 ms *10 ms		0 - 100 A *0 A			
1-88	AC Brake Gain	Activate Brake Speed [Hz]	2-22		
1.0 - 2.0 *1.4		0 - 400 Hz *0 Hz			
1-9*	Motor Temperature	Activate Brake Delay	2-23		
1-90	Motor Thermal Protection	0 - 5 s *0 s			
[0]	No protection	Adv. Mech Brake	2-3*		
[1]	Thermistor warning	Mech. Brake w/ dir. Change	2-39		
[2]	Thermistor trip	OFF	[*0]		
[3]	ETR warning 1	ON	[1]		
[4]	ETR Trip 1	ON with start delay	[2]		
[22]	ETR Trip - Extended Detection	Reference / Ramps	3-3**		
1-93	Thermistor Source	Reference Limits	3-0*		
[0]	None	Reference Range			
[1]	Analog Input 53	Min - Max	[*0]		
[2]	Analog Input 54	-Max - +Max	[1]		
[3]	Digital input 18	Reference/Feedback Unit	3-01		
[4]	Digital input 19	None	[0]		
[5]	Digital input 32	%	[1]		
[6]	Digital input 33	RPM	[2]		
2-*	Brakes	Hz	[3]		
2-0*	DC-Brake	Nm	[4]		
2-00	DC Hold/Motor Preheat Current	PPM	[5]		
0 - 160 % *50 %		1/min	[10]		
2-01	DC Brake Current	Pulse/s	[12]		
0 - 150 % *50 %		l/min	[20]		
2-02	DC Braking Time	l/h	[21]		
0 - 60 s *10 s		m ³ /s	[22]		
2-04	DC Brake Cut In Speed	m ³ /min	[23]		
0 - 500 Hz *0 Hz		m ³ /h	[24]		
2-06	Parking Current	kg/s	[30]		
0 - 150 % *100 %		kg/min	[31]		
2-07	Parking Time	kg/h	[32]		
0.1 - 60 s *3 s		t/min	[33]		
2-1*	Brake Energy Funct.	m/min	[41]		
2-10	Brake Function	m	[45]		
[*0]	Off	°C	[60]		
[1]	Resistor brake	mbar	[70]		
[2]	AC brake	bar	[71]		
		Pa	[72]		
		kPa	[73]		

[8]	Frequency input 33	4-17	Torque Limit Generator Mode	*[1] On	[65]	Reset Counter B	[73]	PID reset I part
[11]	Local bus reference	4-18	0 - 1000 % *100 %	4-6* Speed Bypass	[72]	PID error inverse	[74]	PID enable
3-31	Gen Ramp Settings		Current Limit	4-61 Bypass Speed From [Hz]	[73]	PID reset I part	[150]	Go To Home
*[0]	Ramp Down w/ dir. Change	4-19	0 - 1000 % *Size related	4-63 Bypass Speed To [Hz]	[74]	PID enable	[151]	Home Ref. Switch
[1]	Ramp 1 Ramp Down Time	4-2*	0 - 500 Hz *Size related	5-** Digital In/Out mode	[151]	Home Ref. Switch	[155]	HW Limit Positive Inv
[2]	Ramp 2 Ramp Down Time	4-20	0 - 500 Hz *Size related	5-0* Digital I/O mode	[155]	HW Limit Negative Inv	[156]	HW Limit Positive Inv
[3]	Ramp 3 Ramp Down Time	*[0]	No function	5-00 Digital Input Mode	[156]	Go To Target Pos.	[160]	Pos. Idx Bit0
[4]	Ramp 4 Ramp Down Time	[4]	Analog in 53 inv	[0] NPN	[157]	Pos. Quick Stop Inv	[162]	Pos. Idx Bit1
[9]	Quick Stop Ramp Time	[6]	Analog in 54	[1] NPN	[160]	Go To Target Pos.	[163]	Pos. Idx Bit2
3-4*	Ramp 1	[8]	Analog in 54 inv	*[0] Terminal 27 Mode	[163]	Pos. Idx Bit1	[171]	Limit switch cw inverse
3-40	Ramp 1 Type	4-21	Speed Limit Factor Source	*[0] Input	[164]	Pos. Idx Bit2	[172]	Limit switch ccw inverse
[1]	Linear	*[0]	No function	5-1* Digital Inputs	[171]	Limit switch cw inverse	5-13	Terminal 29 Digital Input
[2]	Sine 2 Ramp	[2]	Analog in 53	5-10 Terminal 18 Digital Input	[172]	Limit switch ccw inverse		Same choices with 5-12
3-41	Ramp 1 Ramp Up Time	[4]	Analog in 53 inv	[0] No operation	5-11	Terminal 19 Digital Input	[30]	Counter input
	0.01 - 3600 s *Size related	[4]	Analog in 54	[1] Reset	5-12	Terminal 27 Digital Input	[32]	Pulse input
3-42	Ramp 1 Ramp Down Time	[6]	Analog in 54 inv	[1] Coast inverse		Encoder input Z	[83]	Encoder input Z
	0.01 - 3600 s *Size related	[8]	Analog in 54 inv	[2] Coast and reset inverse		Terminal 32 Digital Input	5-14	Same choices with 5-12
3-5*	Ramp 2	4-22	Break Away Boost	[3] Coast inverse	[1]	Reset		Same choices with 5-12
	Same contents with 3-4*	*[0]	Off	[4] Quick stop inverse	[2]	Coast inverse	[82]	Encoder input B
3-6*	Ramp 3	[1]	On	[5] DC-brake inverse	[3]	Coast and reset inverse	5-15	Terminal 33 Digital Input
	Same contents with 3-4*	4-3*	Motor Fb Monitor	[6] Stop inverse	[4]	Quick stop inverse		Same choices with 5-12
3-7*	Ramp 4	4-30	Motor Feedback Loss Function	[8] Start	[5]	DC-brake inverse	[30]	Counter input
	Same contents with 3-4*	[0]	Disabled	[9] Latched start	[6]	Stop inverse	[32]	Pulse input
3-8*	Other Ramps	[1]	Warning	[10] Reversing	[8]	Start	[81]	Encoder input A
3-80	Jog Ramp Time	*[2]	Trip	[11] Start reversing	[9]	Latched start	5-19	Terminal 37/38 Safe Torque Off
	0.01 - 3600 s *Size related	[3]	Jog	[12] Enable start forward	[10]	Reversing	*[1]	Safe Torque Off Alarm
3-81	Quick Stop Ramp Time	[4]	Freeze Output	[13] Enable start reverse	[11]	Start reversing	[3]	Safe Torque Off Warning
	0.01 - 3600 s *Size related	[5]	Max Speed	[14] Jog	[12]	Enable start forward	5-3*	Digital Outputs
3-9*	Digital Pot/Meter	[6]	Switch to Open Loop	[15] Preset reference on	[13]	Enable start reverse	5-30	Terminal 27 Digital Output
3-90	Step Size	4-31	Motor Feedback Speed Error	[16] Preset ref bit 0	[14]	Jog	*[0]	No operation
	0.01 - 200 % *0.10 %	4-32	Motor Feedback Loss Timeout	[17] Preset ref bit 1	[15]	Preset reference on	[1]	Control Ready
3-92	Power Restore		0 - 50 Hz *20 Hz	[18] Preset ref bit 2	[16]	Speed up	[2]	Drive ready
*[0]	Off		0 - 60 s *0.05 s	[19] Freeze reference	[17]	Freeze output	[3]	Drive rdy/rem ctrl
[1]	On	4-4*	Adj. Warnings 2	[20] Freeze output	[18]	Freeze reference	[4]	Stand-by / no warning
3-93	Maximum Limit	4-40	Warning Freq. Low	[21] Speed up	[19]	Freeze reference	[5]	Running
	-200 - 200 % *100 %		0 - 500 Hz *Size related	[22] Speed down	[20]	Speed up	[6]	Running / no warning
3-94	Minimum Limit	4-41	Warning Freq. High	[23] Set-up select bit 0	[21]	Speed up	[7]	Run in range/no warn
	-200 - 200 % *100 %		0 - 500 Hz *Size related	[24] Set-up select bit 1	[22]	Speed down	[8]	Run on ref/no warn
3-95	Ramp Delay	4-42	Adjustable Temperature Warning	[26] Precise stop inverse	[23]	Set-up select bit 0	[9]	Alarm
	0 - 3600000 ms *1000 ms		0 - 200 %	[27] Precise start, stop	[24]	Set-up select bit 1	[10]	Alarm or warning
3-96	Maximum Limit Switch Reference	4-5*	Adj. Warnings	[28] Catch up	[28]	Set-up select bit 1	[11]	At torque limit
	0 - 200 % *25 %	4-50	Warning Current Low	[29] Slow down	[29]	Slow down	[12]	Out of current range
4-**	Limits / Warnings		0 - 500 A *0 A	[34] Ramp bit 0	[34]	Ramp bit 0	[13]	Below current, low
4-1*	Motor Limits	4-51	Warning Current High	[35] Ramp bit 1	[35]	Ramp bit 1	[14]	Above current, high
4-10	Motor Speed Direction		0 - 500.00 A *Size related	[40] Latched precise start	[40]	Latched precise start	[15]	Out of frequency range
*[0]	Clockwise	4-54	Warning Reference Low	[41] Latched prec stop inv	[41]	Latched prec stop inv	[16]	Below frequency, low
[2]	Both directions		-4999 - 4999 *4999	[45] Latched start reverse	[45]	Latched start reverse	[17]	Above frequency, high
4-11	Motor Speed Low Limit [RPM]	4-55	Warning Reference High	[51] External Interlock	[51]	External Interlock	[18]	Out of feedb. range
	0 - 1500 RPM *Size related		-4999 - 4999 *4999	[55] DigiPot increase	[55]	DigiPot increase	[19]	Below feedback, low
4-12	Motor Speed Low Limit [Hz]	4-56	Warning Feedback Low	[56] DigiPot decrease	[56]	DigiPot decrease	[20]	Above feedback, high
	0 - 400.0 Hz *0 Hz		-4999 - 4999 ProcessCtrlUnit *4999	[57] DigiPot clear	[57]	DigiPot clear	[21]	Thermal warning
4-13	Motor Speed High Limit [RPM]	4-57	Warning Feedback High	[58] ProcessCtrlUnit	[58]	ProcessCtrlUnit	[22]	Ready, no thermal warning
	0 - 60000 RPM *Size related		-4999 - 4999 ProcessCtrlUnit *4999	[60] Counter A (up)	[60]	Counter A (up)	[23]	Remote,ready,no TW
4-14	Motor Speed High Limit [Hz]		ProcessCtrlUnit	[61] Counter A (down)	[61]	Counter A (down)	[24]	Ready, no over-/ under voltage
	0.1 - 500 Hz *65 Hz	4-58	Missing Motor Phase Function	[62] Reset Counter A	[62]	Reset Counter A	[25]	Reverse
4-16	Torque Limit Motor Mode		Off	[63] Counter B (up)	[63]	Counter B (up)	[26]	Bus OK
	0 - 1000 % *Size related	[0]	Off	[64] Counter B (down)	[64]	Counter B (down)	[27]	Torque limit & stop

[28]	Brake, no brake warning	[5]	Running	[169]	Drive in auto mode	[150]	Go To Home
[29]	Brake ready, no fault	[6]	Running / no warning	[170]	Homings Completed	[151]	Home Ref. Switch
[30]	Brake fault (IGBT)	[7]	Run in range/no warn	[171]	Target Position Reached	[155]	HW Limit Positive Inv
[31]	Relay 123	[8]	Run on ref/no warn	[172]	Position Control Fault	[156]	HW Limit Negative Inv
[32]	Mech brake ctrl	[9]	Alarm	[173]	Position Mech Brake	[157]	Pos. Quick Stop Inv
[36]	Control word bit 11	[10]	Alarm or warning	[190]	STO function active	[160]	Go To Target Pos.
[37]	Control word bit 12	[11]	At torque limit	[193]	Sleep Mode	[162]	Pos. Idx Bit0
[40]	Out of current range	[12]	Out of current range	[194]	Broken Belt Function	[163]	Pos. Idx Bit1
[41]	Below reference, low	[13]	Below current, low	[239]	STO function fault	[164]	Pos. Idx Bit2
[42]	Above ref, high	[14]	Above current, high	5-41	On Delay, Relay	[171]	Limit switch cw inverse
[43]	Extended PID Limit	[15]	Out of frequency range	5-42	Off Delay, Relay	[172]	Limit switch ccw inverse
[45]	Bus ctrl.	[16]	Below frequency, low	5-42	Off Delay, Relay	6-19	Terminal 53 mode
[46]	Bus control, timeout: On	[17]	Above frequency, high	5-5*	Pulse Input	*[1]	Voltage mode
[47]	Bus control, timeout: Off	[18]	Out of feedb. range	5-50	Term. 29 Low Frequency	[6]	Digital input
[55]	Pulse output	[19]	Below feedback, low	5-50	Term. 29 High Frequency	6-2*	Analog Input 54
[56]	Heat sink cleaning warning, high	[20]	Above feedback, high	5-51	Term. 29 High Frequency	6-20	Terminal 54 Low Voltage
[60]	Comparator 0	[21]	Thermal warning	5-52	1 - 32000 Hz *32000 Hz	6-21	Terminal 54 High Voltage
[61]	Comparator 1	[22]	Ready, no thermal warning	5-52	Term. 29 Low Ref./Feedb. Value	6-22	Terminal 54 Low Current
[62]	Comparator 2	[23]	Remote,ready,no TW	5-53	Term. 29 High Ref./Feedb. Value	6-23	Terminal 54 High Current
[63]	Comparator 3	[24]	Ready, no over-/ under voltage	5-55	Term. 33 Low Frequency	6-24	Terminal 54 Low Ref./Feedb. Value
[64]	Comparator 4	[25]	Reverse	5-56	Term. 33 High Frequency	6-25	Terminal 54 High Ref./Feedb. Value
[65]	Comparator 5	[26]	Bus OK	5-57	Term. 33 Low Ref./Feedb. Value	6-26	Terminal 54 Filter Time Constant
[70]	Logic rule 0	[27]	Torque limit & stop	5-58	Term. 33 High Ref./Feedb. Value	6-29	Terminal 54 mode
[71]	Logic rule 1	[28]	Brake, no brake warning	5-60	Terminal 27 Pulse Output Variable	[0]	Current mode
[72]	Logic rule 2	[29]	Brake ready, no fault	*[0]	No operation	*[1]	Voltage mode
[73]	Logic rule 3	[30]	Brake fault (IGBT)	[48]	Bus ctrl.	6-9*	Analog/Digital Output 42
[74]	Logic rule 4	[31]	Relay 123	[100]	Output frequency	6-90	Terminal 42 Mode
[75]	Logic rule 5	[32]	Mech brake ctrl	[102]	Process Feedback	[1]	4-20 mA
[80]	SL digital output A	[36]	Control word bit 11	[103]	Motor Current	[2]	Digital Output
[81]	SL digital output B	[37]	Control word bit 12	[104]	Torque rel to limit	6-91	Terminal 42 Analog Output
[82]	SL digital output C	[40]	Out of ref range	[105]	Torque relate to rated	*[0]	No operation
[83]	SL digital output D	[41]	Below reference, low	[106]	Power	[100]	Output frequency
[91]	Encoder emulate output A	[42]	Above ref, high	[107]	Speed	[101]	Reference
[160]	No alarm	[45]	Bus ctrl.	[109]	Max Out Freq	[102]	Process Feedback
[161]	Running reverse	[46]	Bus control, timeout: On	[113]	PID Clamped Output	[103]	Motor Current
[165]	Local ref active	[47]	Bus control, timeout: Off	5-62	Pulse Output Max Freq 27	[104]	Torque rel to limit
[166]	Remote ref active	[56]	Heat sink cleaning warning, high	5-7*	24V Encoder Input	[105]	Torque relate to rated
[167]	Start command activ	[60]	Comparator 0	5-70	Term 32/33 Pulses Per Revolution	[106]	Power
[168]	Drive in hand mode	[61]	Comparator 1	5-71	Term 32/33 Encoder Direction	[107]	Speed
[169]	Drive in auto mode	[62]	Comparator 2	*[0]	Clockwise	[111]	Speed Feedback
[170]	Homings Completed	[63]	Comparator 3	[1]	Counter clockwise	[113]	PID Clamped Output
[171]	Target Position Reached	[64]	Comparator 4	5-9*	Bus Controlled	[139]	Bus Control
[172]	Position Control Fault	[65]	Comparator 5	5-90	Digital & Relay Bus Control	[143]	Ext. CL 1
[173]	Position Mech Brake	[70]	Logic rule 0	5-93	Pulse Out 27 Bus Control	[254]	DC Link Voltage
[190]	STO function active	[71]	Logic rule 1	5-94	Pulse Out 27 Timeout Preset	6-92	Terminal 42 Digital Output
[193]	Sleep Mode	[72]	Logic rule 2	[160]	No alarm	*[0]	No operation
[194]	Broken Belt Function	[74]	Logic rule 4	[161]	Running reverse	[1]	Control Ready
[239]	STO function fault	[75]	Logic rule 5	[165]	Local ref active	[2]	Drive ready
5-34	On Delay, Digital Output	[80]	SL digital output A	[166]	Remote ref active	[3]	Drive rdy/rem ctrl
5-35	Off Delay, Digital Output	[81]	SL digital output B	[167]	Start command activ	[4]	Stand-by / no warning
		[82]	SL digital output C	[168]	Drive in hand mode		
		[83]	SL digital output D				
		[160]	No alarm				
		[161]	Running reverse				
		[165]	Local ref active				
		[166]	Remote ref active				
		[167]	Start command activ				
		[168]	Drive in hand mode				
		[169]	Drive in auto mode				
		[170]	Homings Completed				
		[171]	Target Position Reached				
		[172]	Position Control Fault				
		[173]	Position Mech Brake				
		[190]	STO function active				
		[193]	Sleep Mode				
		[194]	Broken Belt Function				
		[239]	STO function fault				
		5-34	On Delay, Digital Output				
		5-35	Off Delay, Digital Output				
		5-4*	Relays				
		5-40	Function Relay				
		[0]	No operation				
		*[1]	Control Ready				
		[2]	Drive ready				
		[3]	Drive rdy/rem ctrl				
		[4]	Stand-by / no warning				

[6]	Running / no warning	[170]	Homing Completed	[0]	Off	7-6*	Feedback Conversion	[72]	Logic Rule 2
[7]	Run in range/no warn	[171]	Target Position Reached	[1]	On	7-60	Feedback 1 Conversion	[73]	Logic Rule 3
[8]	Run on ref/no warn	[172]	Position Control Fault	7-32	Process PID Start Speed	[10]	Linear	[74]	Logic Rule 4
[9]	Alarm	[173]	Position Mech Brake	7-33	Process PID Proportional Gain	[1]	Square root	[75]	Logic Rule 5
[10]	Alarm or warning	[193]	Sleep Mode	7-33	Process PID Feed Forward Factor	[10]	Linear	[80]	SL digital out A
[11]	At torque limit	[194]	Broken Belt Function	7-34	Process PID Integral Time	[10]	Square root	[81]	SL digital out B
[12]	Out of current range	[198]	Drive Bypass	7-34	Process PID Differentiation Time	8-2*	General Settings	[82]	SL digital out C
[13]	Below current, low	6-93	Terminal 42 Output Min Scale	7-35	Process PID Diff. Gain Limit	8-0*	General Settings	[83]	SL digital out D
[14]	Above current, high	6-94	Terminal 42 Output Max Scale	7-36	Process PID Feed Forward Factor	8-01	Control Site	[93]	Alarm68 or Alarm188
[15]	Out of frequency range	6-96	Terminal 42 Output Bus Control	7-38	Process PID Feed Fwd Ramp up	[0]	Digital and ctrl.word	8-14	Configurable Control Word CTW
[16]	Below frequency, low	7-0*	Speed PID Ctrl.	7-39	Process PID Diff. Gain Limit	[0]	Digital only	[0]	None
[17]	Above frequency, high	7-00	Speed PID Feedback Source	7-40	Process PID Feed Fwd Ramp down	[1]	Controlword only	[1]	Profile default
[18]	Out of feedb. range	[1]	24V encoder	[1]	Yes	8-02	Control Source	[2]	CTW Valid, active low
[19]	Below feedback, low	[6]	Analog Input 53	[1]	No	[0]	None	[4]	PID error inverse
[20]	Above feedback, high	[7]	Analog Input 54	[1]	Yes	[0]	FC Port	[5]	PID reset I part
[21]	Thermal warning	[8]	Frequency input 29	7-41	Process PID Output Neg. Clamp	[1]	FC USB	[6]	PID enable
[22]	Ready, no thermal warning	[9]	Frequency input 33	7-41	Process PID Output Pos. Clamp	[1]	Product Code	8-19	Product Code
[23]	Remote,ready,no TW	[20]	None	7-42	Process PID Gain Scale at Min. Ref.	8-03	Option A	8-3*	FC Port Settings
[24]	Reverse	7-02	Speed PID Proportional Gain	7-43	Process PID Gain Scale at Max. Ref.	8-04	Control Timeout Time	8-30	Protocol
[25]	Reverse	7-03	Speed PID Integral Time	7-44	Process PID Feed Fwd Resource	[0]	Off	[0]	FC
[26]	Bus OK	7-04	Speed PID Differentiation Time	7-45	Process PID Feed Fwd Normal/ Inv. Ctrl.	[2]	Control Timeout Function	8-31	Address
[27]	Torque limit & stop	7-05	Speed PID Diff. Gain Limit	[0]	Normal	[2]	Freeze output	8-32	Baud Rate
[28]	Brake, no brake warning	7-06	Speed PID Lowpass Filter Time	[1]	Inverse	[3]	Stop	8-32	Baud Rate
[29]	Brake ready, no fault	7-07	Speed PID Feedback Gear Ratio	[7]	Normal	[4]	Jogging	[0]	2400 Baud
[30]	Brake fault (IGBT)	7-08	Speed PID Feed Forward Factor	[8]	Normal	[5]	Max. speed	[1]	4800 Baud
[31]	Relay 123	7-1*	Torque PID Ctrl.	[2]	Inverse	8-07	Diagnosis Trigger	[2]	9600 Baud
[32]	Mech brake ctrl	7-12	Torque PID Proportional Gain	[32]	Bus PCD	[0]	Disable	[3]	19200 Baud
[33]	Control word bit 11	7-13	Torque PID Integration Time	7-46	Process PID Feed Fwd Normal/ Inv. Ctrl.	[1]	Trigger on alarms	[4]	38400 Baud
[34]	Control word bit 12	7-14	Speed PID Feedback Gear Ratio	[0]	Normal	[2]	Trigger alarm/warn.	[5]	57600 Baud
[36]	Control word bit 1	7-15	Speed PID Feed Forward Factor	[1]	Inverse	8-1*	Ctrl. Word Settings	[6]	76800 Baud
[37]	Control word bit 2	7-16	Speed PID Feed Forward Factor	[7]	Frequency input 29	8-10	Control Word Profile	[7]	115200 Baud
[40]	Out of ref range	7-17	Speed PID Feed Forward Factor	[8]	Frequency input 33	[0]	FC profile	8-33	Parity / Stop Bits
[41]	Below reference, low	7-18	Speed PID Feed Forward Factor	[11]	Local bus reference	[1]	PROFdrive profile	[0]	Even Parity, 1 Stop Bit
[42]	Above ref, high	7-19	Torque PID Ctrl.	[32]	Bus PCD	[5]	ODVA	[1]	Odd Parity, 1 Stop Bit
[43]	Bus ctrl.	7-20	Process CL Feedback 1 Resource	7-48	Process PID Feed Fwd Normal/ Inv. Ctrl.	[7]	CANopen DSP 402	[2]	No Parity, 2 Stop Bits
[44]	Bus control, timeout: On	[0]	No function	7-49	Process PID Output Normal/ Inv. Ctrl.	[0]	Configurable Status Word STW	8-35	Minimum Response Delay
[45]	Bus control, timeout: Off	[1]	Analog Input 53	[1]	Normal	[2]	Profile Default	8-36	Maximum Response Delay
[46]	Bus control, timeout: Off	[2]	Analog Input 54	7-48	PCD Feed Forward	[3]	Trip excl Alarm 68		0.0010 - 0.5 s *0.01 s
[47]	Heat sink cleaning warning, high	[4]	Frequency input 29	7-50	Process PID Feed Forward	[10]	T18 DI status		0.1 - 10.0 s *Size related
[56]	Heat sink cleaning warning, high	[0]	Frequency input 33	[11]	Inverse	[11]	T19 DI status	8-4*	FC MC protocol set
[60]	Comparator 0	[1]	Frequency input 33	7-51	Process PID Feed Fwd Gain	[12]	T27 DI status	8-42	PCD Write Configuration
[61]	Comparator 1	[2]	Frequency input 33	7-52	Process PID Feed Fwd Ramp up	[13]	T29 DI status	[0]	None
[62]	Comparator 2	[3]	Process CL Feedback 2 Resource	7-53	Process PID Feed Fwd Ramp down	[14]	T32 DI status	[1]	[302] Minimum Reference
[63]	Comparator 3	[4]	No function	7-54	Process PID Ref. Filter Time	[15]	T33 DI status	[2]	[303] Maximum Reference
[64]	Comparator 4	[0]	No function	7-55	Process PID Normal/ Inverse Control	[16]	T29 DI status	[3]	[341] Ramp 1 Ramp up time
[65]	Comparator 5	[1]	Analog Input 53	7-56	Process PID Normal/ Inverse Control	[17]	T32 DI status	[4]	[342] Ramp 1 Ramp down time
[70]	Logic rule 0	[2]	Analog Input 54	7-57	Process PID Fb. Filter Time	[18]	T33 DI status	[5]	[351] Ramp 2 Ramp up time
[71]	Logic rule 1	[3]	Frequency input 29	[0]	Normal	[19]	Thermal warning	[6]	[352] Ramp 2 Ramp down time
[72]	Logic rule 2	[4]	Frequency input 33	7-58	Process PID Anti Windup	[20]	Brake fault (IGBT)	[7]	[380] Jog Ramp Time
[73]	Logic rule 3	[1]	Process CL Feedback 1 Resource	7-59	Process PID Feed Fwd Ramp up	[21]	Out of ref range	[8]	[381] Quick Stop Time
[74]	Logic rule 4	[2]	Process CL Feedback 2 Resource	7-60	Process PID Feed Fwd Ramp down	[22]	Comparator 0	[9]	[412] Motor Speed Low Limit [Hz]
[75]	Logic rule 5	[3]	No function	7-61	Process PID Ref. Filter Time	[23]	Comparator 1	[10]	[414] Motor Speed High Limit [Hz]
[80]	SL digital output A	[4]	Process CL Feedback 1 Resource	7-62	Process PID Ref. Filter Time	[24]	Comparator 2	[11]	[590] Digital & Relay Bus Control
[81]	SL digital output B	[1]	Process CL Feedback 2 Resource	7-63	Process PID Fb. Filter Time	[25]	Comparator 3	[12]	[676] Terminal 45 Output Bus Control
[82]	SL digital output C	[2]	Process CL Feedback 2 Resource	7-64	Process PID Fb. Filter Time	[26]	Comparator 4	[13]	[696] Terminal 42 Output Bus Control
[83]	SL digital output D	[3]	Process CL Feedback 2 Resource	7-65	Process PID Fb. Filter Time	[27]	Comparator 5	[14]	FC Port CTW
[160]	No alarm	[0]	No function	7-66	Process PID Anti Windup	[28]	Logic Rule 1	[15]	
[161]	Running reverse	[1]	Analog Input 53						
[165]	Local ref active	[2]	Analog Input 54						
[166]	Remote ref active	[3]	Frequency input 29						
[167]	Start command active	[4]	Frequency input 33						
[168]	Drive in hand mode	[5]	Process CL Feedback 1 Resource						
[169]	Drive in auto mode	[6]	Process CL Feedback 2 Resource						

Address	Parameter Name	Factory Default	Description	Parameter Name	Factory Default	Description
[16]	FC Port REF			[341]	Ramp 1 Ramp Up Time	[1639] Control Card Temp.
8-43	PCD Read Configuration			[342]	Ramp 1 Ramp Down Time	[1650] External Reference
[0]	None			[351]	Ramp 2 Ramp Up Time	*[1] Enabled
[1]	[1500] Operation Hours			[352]	Ramp 2 Ramp Down Time	9-28 Process Control
[2]	[1501] Running Hours			[380]	Jog Ramp Time	[0] Disable
[3]	[1502] kWh Counter			[381]	Quick Stop Ramp Time	*[1] Enable cyclic master
[4]	[1600] Control Word			[412]	Motor Speed Low Limit [Hz]	9-44 Fault Message Counter
[5]	[1601] Reference [Unit]			[414]	Motor Speed High Limit [Hz]	0 - 65535 *0
[6]	[1602] Reference %			[416]	Torque Limit Motor Mode	9-45 Fault Code
[7]	[1603] Status Word			[417]	Torque Limit Generator Mode	0 - 0 *0
[8]	[1605] Main Actual Value [%]			[553]	Term. 29 High Ref./Feedb. Value	9-47 Fault Number
[9]	[1609] Custom Readout			[558]	Term. 33 High Ref./Feedb. Value	0 - 0 *0
[10]	[1610] Power [kW]			[590]	Digital & Relay Bus Control	9-52 Fault Situation Counter
[11]	[1611] Power [hp]			[593]	Pulse Out 27 Bus Control	0 - 1000 *0
[12]	[1612] Motor Voltage			[615]	Terminal 53 High Ref./Feedb. Value	9-53 Profibus Warning Word
[13]	[1613] Frequency			[625]	Terminal 54 High Ref./Feedb. Value	0 - 65535 *0
[14]	[1614] Motor Current			[696]	Terminal 42 Output Bus Control	Actual Baud Rate
[15]	[1615] Frequency [%]			[748]	PCD Feed Forward	[0] 9.6 kbit/s
[16]	[1616] Torque [Nm]			[890]	Bus Jog 1 Speed	[1] 19.2 kbit/s
[17]	[1618] Motor Thermal			[891]	Bus Jog 2 Speed	[2] 93.75 kbit/s
[18]	[1630] DC Link Voltage			[1680]	Fieldbus CTW 1	[3] 187.5 kbit/s
[19]	[1634] Heatsink Temp.			[1682]	Fieldbus REF 1	[4] 500 kbit/s
[20]	[1635] Inverter Thermal			[3401]	PCD 1 Write For Application	[5] 1500 kbit/s
[21]	[1638] SL Controller State			[3402]	PCD 2 Write For Application	[6] 3000 kbit/s
[22]	[1650] External Reference			[3403]	PCD 3 Write For Application	[7] 6000 kbit/s
[23]	[1652] Feedback [Unit]			[3404]	PCD 4 Write For Application	[8] 12000 kbit/s
[24]	[1660] Digital Input 18,19,27,33			[3405]	PCD 5 Write For Application	[9] 31.25 kbit/s
[25]	[1661] Terminal 53 Switch Setting			[3406]	PCD 6 Write For Application	[10] 45.45 kbit/s
[26]	[1662] Analog input 53			[3407]	PCD 7 Write For Application	[11] No baudrate found
[27]	[1663] Terminal 54 Switch Setting			[3408]	PCD 8 Write For Application	9-64 Device Identification
[28]	[1664] Analog input 54			[3409]	PCD 9 Write For Application	0 - 0 *0
[29]	[1665] Analog output 42 [mA]			[3410]	PCD 10 Write For Application	9-65 Profile Number
[30]	[1671] Relay output			9-16 PCD Read Configuration		0 - 0 *0
[31]	[1672] Counter A			[0]	None	0 - 0 *0
[32]	[1673] Counter B			[1500]	Operating hours	Control Word 1
[33]	[1690] Alarm Word			[1501]	Running Hours	0 - 65535 *0
[34]	[1692] Warning Word			[1502]	kWh Counter	Status Word 1
[35]	[1694] Ext. Status Word			[1600]	Control Word	0 - 65535 *0
8-5*	Digital/Bus			[1601]	Reference [Unit]	Edit Set-up
8-50	Coasting Select			[1602]	Reference [%]	[1] Set-up 1
[0]	Digital input			[1603]	Status Word	[2] Set-up 2
[1]	Bus			[1605]	Main Actual Value [%]	[3] Set-up 3
[2]	Logic AND			[1609]	Custom Readout	[4] Set-up 4
[3]	Logic OR			[1610]	Power [kW]	*[9] Active Set-up
8-51	Quick Stop Select			[1611]	Power [hp]	9-71 Profibus Save Data Values
[0]	Digital input			[1612]	Motor Voltage	*[0] Off
[1]	Bus			[1613]	Frequency	[1] Store all setups
*[3]	Logic OR			[1614]	Motor current	[11] ProfibusDriveReset
8-52	DC Brake Select			[1615]	Frequency [%]	*[0] No action
[0]	Digital input			[1616]	Torque [Nm]	[1] Power-on reset
[1]	Bus			[1617]	Speed [RPM]	[2] Power-on reset prep
[2]	Logic AND			[1618]	Motor Thermal	[3] Comm option reset
*[3]	Logic OR			[1620]	Motor Angle	9-75 DO Identification
9-00	Setpoint			[1622]	Torque [%]	0 - 65535 *0
[0]	Bus			[1630]	DC Link Voltage	Defined Parameters (1)
[1]	Bus			[1633]	Brake Energy /2 min	0 - 9999 *0
[2]	Logic AND			[1635]	Heatsink Temp.	Defined Parameters (2)
*[3]	Logic OR			[1638]	Inverter Thermal	0 - 9999 *0
9-07	Actual Value				SL Controller State	Defined Parameters (3)
[0]	Bus					0 - 9999 *0
[1]	Bus					
[2]	Logic AND					
*[3]	Logic OR					
9-15	PCD Write Configuration					
[0]	Digital input					
[1]	Bus					
[2]	Logic AND					
*[3]	Logic OR					
9-19	Drive Unit System Number					
[0]	Bus					
[1]	Bus					
[2]	Logic AND					
*[3]	Logic OR					
9-22	Telegram Selection					
[0]	Bus					
[1]	Bus					
[2]	Logic AND					
*[3]	Logic OR					
9-23	Standard telegram 1					
[0]	Bus					
[1]	Bus					
[2]	Logic AND					
*[3]	Logic OR					
9-25	DO Identification					
[0]	Bus					
[1]	Bus					
[2]	Logic AND					
*[3]	Logic OR					
9-71	Profibus Save Data Values					
*[0]	Off					
[1]	Store all setups					
[11]	ProfibusDriveReset					
*[0]	No action					
[1]	Power-on reset					
[2]	Power-on reset prep					
[3]	Comm option reset					
9-75	DO Identification					
[0]	Bus					
[1]	Bus					
[2]	Logic AND					
*[3]	Logic OR					
9-80	Defined Parameters (1)					
[0]	Bus					
[1]	Bus					
[2]	Logic AND					
*[3]	Logic OR					
9-81	Defined Parameters (2)					
[0]	Bus					
[1]	Bus					
[2]	Logic AND					
*[3]	Logic OR					
9-82	Defined Parameters (3)					
[0]	Bus					
[1]	Bus					
[2]	Logic AND					
*[3]	Logic OR					
9-23	Same choices with 9-15 & 9-16					

9-83	Defined Parameters (4) 0 - 9999 *0	12-05	Lease Expires 0 - 4294967295 *0	[1682]	Fieldbus REF 1	[1690]	Alarm Word	0 - 4294967295 *0
9-84	Defined Parameters (5) 0 - 9999 *0	12-06	Name Servers 0 - 4294967295 *0	[3402]	PCD 2 Write For Application	[1691]	Alarm Word 2	Cumulative Counters 0 - 2147483647 *0
9-85	Defined Parameters (6) 0 - 9999 *0	12-07	Domain Name 1 - 48 *0	[3403]	PCD 3 Write For Application	[1692]	Warning Word	Ethernet PowerLink Status 0 - 4294967295 *0
9-90	Changed Parameters (1) 0 - 9999 *0	12-08	Host Name 1 - 48 *0	[3404]	PCD 4 Write For Application	[1693]	Warning Word 2	12-8* Other Ethernet Services
9-91	Changed Parameters (2) 0 - 9999 *0	12-09	Physical Address 0 - 17 *0	[3405]	PCD 5 Write For Application	[1694]	Ext. Status Word	12-80 FTP Server * [0] Disabled
9-92	Changed Parameters (3) 0 - 9999 *0	12-1* Ethernet Link Parameters		[3406]	PCD 6 Write For Application	[1695]	Ext. Status Word 2	12-81 HTTP Server * [0] Disabled
9-93	Changed Parameters (4) 0 - 9999 *0	12-10	Link Status * [0] No Link	[3407]	PCD 7 Write For Application	[1696]	Warning Word 3	12-82 SMTP Service * [0] Disabled
9-94	Changed Parameters (5) 0 - 9999 *0	12-11	Link Duration 0 - 0 *Size related	[1500]	Operating hours	[3421]	PCD 1 Read For Application	12-83 SNMP Agent * [0] Disabled
9-99	Profibus Revision Counter 0 - 65535 *0	12-12	Auto Negotiation * [0] Off	[1501]	Running Hours	[3422]	PCD 2 Read For Application	12-84 Address Conflict Detection * [1] Enabled
10-0** CAN Fieldbus Common Settings		12-13	Link Speed * [0] None	[1602]	Reference [Unit]	[3423]	PCD 3 Read For Application	12-85 Transparent Socket Channel Port 0 - 65535 *4000
10-01	Baud Rate Select	[1603]	Status Word	[1605]	Main Actual Value [%]	[3424]	PCD 4 Read For Application	12-9* Advanced Ethernet Services
[16]	10 Kbps	[1609]	Custom Readout	[1609]	Operating hours	[3425]	PCD 5 Read For Application	12-90 Cable Diagnostic * [0] Disabled
[17]	20 Kbps	[1610]	Power [kW]	[1610]	Power [hp]	[3426]	PCD 6 Read For Application	12-91 Auto Cross Over * [0] Disabled
[18]	50 Kbps	[1611]	Link Duplex	[1611]	Motor current	[3427]	PCD 7 Read For Application	12-92 IGMP Snooping * [1] Enabled
[20]	125 Kbps	[1612]	Half Duplex	[1612]	Motor Voltage	[3428]	PCD 8 Read For Application	12-93 Cable Error Length 0 - 65535 *0
[21]	250 Kbps	[1613]	Full Duplex	[1613]	Frequency	[3429]	PCD 9 Read For Application	12-94 Broadcast Storm Protection -1 - 20 % *-1 %
[22]	500 Kbps	[1614]	Supervisor MAC	[1614]	Motor current	[3430]	PCD 10 Read For Application	12-95 Inactivity timeout 0 - 3600 *120
[23]	800 Kbps	[1615]	Supervisor IP Addr.	[1615]	Frequency [%]	[3431]	PCD 1 Read For Application	12-96 Port Config Normal
[24]	1000 Kbps	[1616]	Supervisor IP Addr.	[1616]	Torque [Nm]	[3432]	PCD 2 Read For Application	12-97 QoS Priority 0 - 63 *Size related
10-02	Node ID 1 - 127 *127	[1617]	Speed [RPM]	[1617]	Speed [RPM]	[3433]	PCD 3 Read For Application	12-98 Interface Counters 0 - 4294967295 *4000
10-05	Readout, Transmit Error Counter 0 - 255 *0	12-2* Process Instance		[1618]	Motor Thermal	[3434]	PCD 4 Read For Application	12-99 Media Counters 0 - 4294967295 *0
10-06	Readout, Receive Error Counter 0 - 255 *0	12-20	Control Instant	[1620]	Motor Angle	[3435]	PCD 5 Read For Application	13-** Smart Logic
10-3* Parameter Access		12-21	Readout, Transmit Error Counter 0 - 255 *0	[1622]	Torque [%]	[3436]	PCD 6 Read For Application	13-00 SLC Settings
* [0] Off		[302]	Minimum Reference	[1633]	Brake Energy /2 min	[3437]	PCD 7 Read For Application	* [0] Off
[2]	Store all setups	[303]	Maximum Reference	[1633]	DC Link Voltage	[3438]	PCD 8 Read For Application	[1] On
[3]	Store edit setup	[312]	Catch up/slow Down Value	[1634]	Heatsink Temp.	[3439]	PCD 9 Read For Application	[2] Mirror Port 1 to 2
* [0] Off		[341]	Ramp 1 Ramp Up Time	[1635]	Inverter Thermal	[3440]	PCD 10 Read For Application	[2] Mirror Port 2 to 1
[1]	On	[342]	Ramp 1 Ramp Down Time	[1638]	SL Controller State	[3441]	PCD 1 Read For Application	[10] Port 1 disabled
[1]	On	[351]	Ramp 2 Ramp Up Time	[1639]	Control Card Temp.	[3442]	PCD 2 Read For Application	[11] Port 2 disabled
[1]	On	[352]	Ramp 2 Ramp Down Time	[1652]	Feedback[Unit]	[3443]	PCD 3 Read For Application	[254] Mirror Int. Port to 1
[1]	On	[380]	Jog Ramp Time	[1653]	Digi Pot Reference	[3444]	PCD 4 Read For Application	[255] Mirror Int. Port to 2
[1]	On	[381]	Quick Stop Ramp Time	[1657]	Feedback [RPM]	[3445]	PCD 5 Read For Application	12-99 QoS Priority 0 - 63 *Size related
[1]	On	[412]	Motor Speed Low Limit [Hz]	[1660]	Digital Input	[3446]	PCD 6 Read For Application	12-98 Ethernet PowerLink
[1]	On	[414]	Motor Speed High Limit [Hz]	[1661]	Terminal 53 Setting	[3447]	PCD 7 Read For Application	12-60 Node ID 1 - 239 *1
[1]	On	[416]	Torque Limit Motor Mode	[1662]	Analog input 53	[3448]	PCD 8 Read For Application	12-62 SDO Timeout 0 - 200000000 ms *30000 ms
[1]	On	[553]	Term. 29 High Ref./Feedb. Value	[1663]	Terminal 54 Setting	[3449]	PCD 9 Read For Application	12-63 Basic Ethernet Timeout 0 - 2000000.000 ms *5000.000 ms
[1]	On	[590]	Term. 33 High Ref./Feedb. Value	[1664]	Analog input 54	[3450]	PCD 10 Read For Application	12-66 Threshold 0 - 2000000000 *15
[1]	On	[593]	Pulse Out 27 Bus Control	[1665]	Analog output 42 [mA]	[3451]	PCD 1 Read For Application	12-67 Threshold Counters
[1]	On	[615]	Terminal 53 High Ref./Feedb. Value	[1666]	Digital Output	[3452]	PCD 2 Read For Application	
[1]	On	[625]	Terminal 54 High Ref./Feedb. Value	[1667]	Pulse input 29 [Hz]	[3453]	PCD 3 Read For Application	
[1]	On	[696]	Terminal 42 Output Bus Control	[1668]	Pulse input 33 [Hz]	[3454]	PCD 4 Read For Application	
[1]	On	[748]	PCD Feed Forward	[1669]	Pulse output 27 [Hz]	[3455]	PCD 5 Read For Application	
[1]	On	[891]	Bus Jog 1 Speed	[1671]	Relay output	[3456]	PCD 6 Read For Application	
[1]	On	[1680]	Fieldbus CTW 1	[1672]	Counter A	[3457]	PCD 7 Read For Application	
[1]	On			[1673]	Counter B	[3458]	PCD 8 Read For Application	
[1]	On			[1674]	Prec. Stop Counter	[3459]	PCD 9 Read For Application	
[1]	On			[1684]	Comm. Option STW	[3460]	PCD 10 Read For Application	
[1]	On			[1685]	FC Port CTW 1	[3461]	PCD 1 Read For Application	

[32]	False	SL Time-out 2	[32]	SL Time-out 2	[19]	Warning	[18]	Reversing	[32]	Set digital out A low
[33]	True	Digital input DI18	[20]	Alarm (trip)	[20]	Alarm (trip)	[19]	Warning	[33]	Set digital out B low
[34]	Running	Digital input DI19	[21]	Alarm (trip lock)	[21]	Alarm (trip lock)	[20]	Alarm (trip)	[34]	Set digital out C low
[35]	In range	Digital input DI27	[22]	Comparator 0	[22]	Comparator 0	[21]	Alarm (trip lock)	[35]	Set digital out D low
[4]	On reference	Digital input DI29	[23]	Comparator 1	[23]	Comparator 1	[22]	Comparator 0	[38]	Set digital out A high
[7]	Out of current range	Start command	[24]	Comparator 2	[24]	Comparator 2	[23]	Comparator 1	[39]	Set digital out B high
[8]	Below I low	Drive stopped	[25]	Comparator 3	[25]	Comparator 3	[24]	Comparator 2	[40]	Set digital out C high
[9]	Above I high	Auto Reset Trip	[26]	Comparator 4	[26]	Logic rule 1	[25]	Comparator 3	[41]	Set digital out D high
[16]	Thermal warning	Comparator 4	[27]	Comparator 5	[27]	Logic rule 2	[26]	Logic rule 0	[60]	Reset Counter A
[17]	Mains out of range	Comparator 5	[28]	Comparator 5	[28]	Logic rule 3	[27]	Logic rule 1	[61]	Reset Counter B
[18]	Reversing	Logic rule 4	[29]	Logic rule 5	[29]	Logic rule 4	[28]	Logic rule 2	[70]	Start Timer 3
[19]	Warning	Logic rule 5	[30]	SL Time-out 0	[30]	SL Time-out 0	[29]	Logic rule 3	[71]	Start Timer 4
[20]	Alarm (trip)	SL Time-out 3	[31]	SL Time-out 1	[31]	SL Time-out 1	[30]	SL Time-out 0	[72]	Start Timer 5
[21]	Alarm (trip lock)	SL Time-out 4	[32]	SL Time-out 2	[32]	SL Time-out 2	[31]	SL Time-out 1	[73]	Start Timer 6
[22]	Comparator 0	SL Time-out 5	[33]	Digital input DI18	[33]	Digital input DI18	[32]	SL Time-out 2	[74]	Start Timer 7
[23]	Comparator 1	SL Time-out 6	[34]	Digital input DI19	[34]	Digital input DI19	[33]	Digital input DI18	14-01 Special Functions	
[24]	Comparator 2	SL Time-out 7	[35]	Digital input DI27	[35]	Digital input DI27	[34]	Digital input DI19	14-02 Inverter Switching	
[25]	Comparator 3	Broken Belt	[36]	Digital input DI29	[36]	Digital input DI29	[35]	Digital input DI27	[0]	Switching Frequency
[26]	Logic rule 0	13-03 Reset SLC	[39]	Start command	[39]	Start command	[36]	Digital input DI29	[1]	Ran3
[27]	Logic rule 1	*[0] Do not reset SLC	[40]	Drive stopped	[40]	Drive stopped	[39]	Start command	[2]	2.0 kHz
[28]	Logic rule 2	[1] Reset SLC	[42]	Auto Reset Trip	[42]	Auto Reset Trip	[40]	Drive stopped	[3]	3.0 kHz
[29]	Logic rule 3	13-1* Comparators	[50]	Comparator 4	[50]	Comparator 4	[42]	Auto Reset Trip	[4]	4.0 kHz
[33]	Digital input DI18	13-10 Comparator Operand	[51]	Comparator 5	[51]	Comparator 5	[50]	Comparator 4	[5]	5.0 kHz
[34]	Digital input DI19	*[0] Disabled	[60]	Logic rule 4	[60]	Logic rule 4	[51]	Comparator 5	[6]	6.0 kHz
[35]	Digital input DI27	[1] Reference %	[61]	Logic rule 5	[61]	Logic rule 5	[60]	Logic rule 4	[7]	8.0 kHz
[36]	Digital input DI29	[2] Feedback %	[70]	SL Time-out 3	[70]	SL Time-out 3	[61]	Logic rule 5	[8]	10.0 kHz
*[39]	Start command	[3] Motor speed	[71]	SL Time-out 4	[71]	SL Time-out 4	[70]	SL Time-out 3	[9]	12.0 kHz
[40]	Drive stopped	[4] Motor current	[72]	SL Time-out 5	[72]	SL Time-out 5	[71]	SL Time-out 4	[10]	16.0 kHz
[42]	Auto Reset Trip	[6] Motor power	[73]	SL Time-out 6	[73]	SL Time-out 6	[72]	SL Time-out 5	14-03 Overmodulation	
[50]	Comparator 4	[7] Motor voltage	[74]	SL Time-out 7	[74]	SL Time-out 7	[73]	SL Time-out 6	[0]	Off
[51]	Comparator 5	[12] Analog input AI53	[83]	Broken Belt	[83]	Broken Belt	[74]	SL Time-out 7	[1]	On
[60]	Logic rule 4	[13] Analog input AI54	13-41	Logic Rule Operator 1	13-41	Logic Rule Operator 1	[83]	Broken Belt	[14-07]	Dead Time Compensation Level
[61]	Logic rule 5	[18] Pulse input FI29	*[0] Disabled	[10] Disabled	*[0]	Disabled	[83]	Broken Belt	[0 - 100 %]	*Size related
[83]	Broken Belt	[19] Pulse input FI33	[1]	AND	[1]	AND	[83]	Broken Belt	[14-08]	Damping Gain Factor
13-02	Stop Event	[20] Alarm number	[2]	OR	[2]	OR	[10]	Disabled	[0 - 100 %]	*Size related
[0]	False	[30] Counter A	[3]	AND NOT	[3]	AND NOT	[11]	No action	[14-09]	Dead Time Bias Current Level
[1]	True	[31] Counter B	[4]	OR NOT	[4]	OR NOT	[11]	No action	[0 - 100 %]	*Size related
[2]	Running	13-11 Comparator Operator	[5]	NOT AND	[5]	NOT AND	[11]	Select set-up 1	[0 - 100 %]	*Size related
[3]	In range	[0] Less Than (<)	[6]	NOT OR	[6]	NOT OR	[11]	Select set-up 2	[14-1*	Mains On/Off
[4]	On reference	*[1] Approx.Equal (=)	[7]	NOT OR NOT	[7]	NOT OR NOT	[10]	Select set-up 3	14-10	Mains Failure
[7]	Out of current range	[2] Greater Than (>)	[8]	NOT OR NOT	[8]	NOT OR NOT	[11]	Select set-up 4	*[0]	No function
[8]	Below I low	13-12 Comparator Value	13-42	Logic Rule Boolean 2	13-42	Logic Rule Boolean 2	[11]	Select preset ref 0	[1]	Ctrl. ramp-down
[9]	Above I high	-9999 - 9999 *0	13-43	Logic Rule Operator 2	13-43	Logic Rule Operator 2	[12]	Select preset ref 1	[2]	Ctrl. ramp-down, trip
[16]	Thermal warning	13-2* Timers	13-44	Logic Rule Boolean 3	13-44	Logic Rule Boolean 3	[13]	Select preset ref 2	[3]	Coasting
[17]	Mains out of range	13-20 SL Controller Timer	13-44	Logic Rule Boolean 3	13-44	Logic Rule Boolean 3	[13]	Select preset ref 3	[4]	Kinetic back-up
[18]	Reversing	0 - 3600 s *0 s	13-5*	States	13-5*	States	[14]	Select preset ref 4	[5]	Kinetic back-up, trip
[19]	Warning	13-4* Logic Rules	13-42	Same choices with 13-42	13-42	Same choices with 13-42	[15]	Select preset ref 5	[6]	Alarm
[20]	Alarm (trip)	13-40 Logic Rule Boolean 1	13-42	Same choices with 13-42	13-42	Same choices with 13-42	[16]	Select preset ref 6	[7]	Kin. back-up, trip w recovery
[21]	Alarm (trip lock)	*[0] False	13-51	SL Controller Event	13-51	SL Controller Event	[17]	Select preset ref 7	14-11	Mains Fault Voltage Level
[22]	Comparator 0	[1] True	[10]	False	[10]	False	[17]	Select ramp 1	100 - 800 V	*Size related
[23]	Comparator 1	[2] Running	[11]	True	[11]	True	[18]	Select ramp 2	14-12	Response to Mains Imbalance
[24]	Comparator 2	[3] In range	[2]	Running	[2]	Running	[19]	Select ramp 2	*[0]	Trip
[25]	Comparator 3	[4] On reference	[3]	In range	[3]	In range	[22]	Run	[1]	Warning
[26]	Logic rule 0	[7] Out of current range	[4]	On reference	[4]	On reference	[23]	Run reverse	[2]	Disabled
[27]	Logic rule 1	[8] Below I low	[7]	Out of current range	[7]	Out of current range	[24]	Stop	[14-15	Kin. Back-up Trip Recovery Level
[28]	Logic rule 2	[9] Above I high	[8]	Below I low	[8]	Below I low	[25]	Ostop	0 - 60000.000	ReferenceFeedBackUnit
[29]	Logic rule 3	[16] Thermal warning	[9]	Above I high	[9]	Above I high	[26]	DC Brake	*Size related	
[30]	SL Time-out 0	[17] Mains out of range	[16]	Thermal warning	[16]	Thermal warning	[27]	Coast	14-2* Reset Functions	
[31]	SL Time-out 1	[18] Reversing	[17]	Mains out of range	[17]	Mains out of range	[28]	Freeze output	[14-20	Reset Mode
							[29]	Start timer 0		
							[30]	Start timer 1		
							[31]	Start timer 2		

[0] Manual reset	14-6 Auto Derate	15-3* Alarm Log	-4999 - 4999 ReferenceFeedbackUnit *0	16-57 Feedback [RPM]
[1] Automatic reset x 1	14-61 Function at Inverter Overload	15-30 Alarm Log: Error Code	ReferenceFeedbackUnit	16-58 ReferenceFeedbackUnit
[2] Automatic reset x 2	[*][0] Trip	0 - 255 *0	16-02 Reference [%]	16-60 Digital Input
[3] Automatic reset x 3	[1] Derate	15-31 InternalFaultReason	-200 - 200 % *0 %	16-61 Terminal 53 Setting
[4] Automatic reset x 4	14-63 Min Switch Frequency	-32767 - 32767 *0	16-03 Status Word	[1] Voltage mode
[5] Automatic reset x 5	[*][2] 2.0 kHz	15-4* Drive Identification	0 - 65535 *0	[6] Digital input
[6] Automatic reset x 6	[3] 3.0 kHz	15-40 FC Type	16-05 Main Actual Value [%]	16-62 Analog input 53
[7] Automatic reset x 7	[4] 4.0 kHz	0 - 0 *0	-200 - 200 % *0 %	0 - 20 *1
[8] Automatic reset x 8	[5] 5.0 kHz	15-41 Power Section	16-09 Custom Readout	16-63 Terminal 54 Setting
[9] Automatic reset x 9	[6] 6.0 kHz	0 - 20 *0	0 - 9999 CustomReadoutUnit *0	[0] Current mode
[10] Automatic reset x 10	[7] 8.0 kHz	15-42 Voltage	CustomReadoutUnit	[1] Voltage mode
[11] Automatic reset x 15	[8] 10.0 kHz	0 - 20 *0	16-1* Motor Status	16-64 Analog input 54
[12] Automatic reset x 20	[9] 12.0 kHz	0 - 0 *0	16-10 Power [kW]	0 - 20 *1
[13] Infinite auto reset	[10] 16.0 kHz	15-43 Software Version	0 - 1000 kW *0 kW	16-65 Analog output 42 [mA]
[14] Reset at power-up	14-64 Dead Time Compensation Zero Current Level	15-44 Ordered TypeCode	16-11 Power [hp]	16-66 Digital Output
14-21 Automatic Restart Time	0 - 41 *0	0 - 40 *0	0 - 1000 hp *0 hp	16-67 Pulse input 29 [Hz]
14-22 Operation Mode	[*][0] Disabled	15-45 Actual Typecode String	16-12 Motor Voltage	16-68 Pulse input 33 [Hz]
[*][0] Normal operation	[1] Enabled	0 - 0 *0	0 - 65535 V *0 V	16-69 Pulse output 27 [Hz]
[2] Initialisation	14-65 Speed Derate Dead Time Compensation	15-46 Drive Ordering No	16-13 Frequency	16-71 Relay output
14-24 Trip Delay at Current Limit	20 - 1000 Hz *Size related	0 - 0 *0	0 - 6553.5 Hz *0 Hz	16-72 Counter A
14-25 Trip Delay at Torque Limit	14-7* Compatibility	15-48 LCP Id No	16-14 Motor current	16-73 Counter B
0 - 60 s *60 s	14-70 Compatibility Selections	0 - 0 *0	0 - 655.35 A *0 A	16-74 Prec. Stop Counter
0 - 60 s *60 s	[*][0] No Function	15-49 SW ID Control Card	16-15 Frequency [%]	0 - 2147483647 *0
14-27 Action At Inverter Fault	[12] VLT2800 3M	15-50 SW ID Power Card	16-16 Torque [Nm]	16-8* Fieldbus & FC Port
[*][1] Warning	[13] VLT2800 3M incl. MAV	0 - 0 *0	-30000 - 30000 Nm *0 Nm	16-80 Fieldbus CTW 1
*[0] No action	[14] VLT2800 12M	15-51 Drive Serial Number	16-17 Speed [RPM]	0 - 65535 *0
[1] Service reset	14-28 Production Settings	0 - 0 *0	-30000 - 30000 RPM *0 RPM	Fieldbus REF 1
[3] Software Reset	14-8* Options	15-52 OEM Information	16-18 Motor Thermal	Comm. Option STW
14-29 Service Code	14-88 Option Data Storage	0 - 0 *0	0 - 100 % *0 %	FC Port CTW 1
0 - 0x7fffff *0	0 - 65535 *0	15-53 Power Card Serial Number	16-20 Motor Angle	0 - 65535 *1084
14-3* Current Limit Ctrl, Proportional Gain	14-89 Option Detection	0 - 0 *0	0 - 100 % *0 %	FC Port REF 1
14-30 Current Lim Ctrl, Integration Time	[*][0] Protect Option Config.	15-57 File Version	16-22 Torque [%]	16-9* Diagnosis Readouts
0.002 - 2 s *0.020 s	[1] Enable Option Change	0 - 255 *0	16-3* Drive Status	16-90 Alarm Word
14-32 Current Lim Ctrl, Filter Time	14-9* Fault Settings	15-59 Filename	16-30 DC Link Voltage	Alarm Word 2
1 - 100 ms *5 ms	14-90 Fault Level	0 - 16 *0	0 - 65535 V *0 V	Alarm Word 3
14-4* Energy Optimising	[*][3] Trip Lock	15-6* Option Ident	16-33 Brake Energy /2 min	0 - 0x7fffff *0
14-40 V1 Level	[4] Trip w. delayed reset	0 - 30 *Size related	0 - 10000 kW *0 kW	Warning Word
40 - 90 % *66 %	[5] Flystart	0 - 20 *Size related	-128 - 127 *0 *0 °C	Warning Word 2
14-41 AEO Minimum Magnetisation	15-0* Operating Data	15-70 Option in Slot A	16-35 Inverter Thermal	0 - 0x7fffff *0
40 - 75 % *66 %	15-00 Operating hours	0 - 30 *0	0 - 255 % *0 %	0 - 65535 *1084
d-axis current optimization for IPM	15-01 Running Hours	15-71 Slot A Option SW Version	16-36 Inv. Nom. Current	32768 - 32767 *0
0 - 200 % *100 %	0 - 0x7fffff. h *0 h	0 - 20 *0	0 - 655.35 A *0 A	16-91 Alarm Word 2
14-5* Environment	15-02 kWh Counter	15-9* Parameter Info	16-37 Inv. Max. Current	0 - 0x7fffff *0
14-51 DC-Link Voltage Compensation	0 - 2147483647 kWh *0 kWh	15-92 Defined Parameters	0 - 655.35 A *0 A	Alarm Word 3
[*][0] Off	15-03 Power Up s	0 - 2000 *0	16-38 SL Controller State	0 - 0x7fffff *0
[*][1] On	0 - 2147483647 *0	15-97 Application Type	0 - 20 *0	0 - 0x7fffff *0
[5] Fan Control	15-04 Over Temp's	0 - 0x7fffff *0	16-39 Control Card Temp.	0 - 0x7fffff *0
[6] Constant-on mode	0 - 65535 *0	15-98 Drive Identification	0 - 65535 °C *0 °C	0 - 0x7fffff *0
[7] On-when-inverter-is-on-else-off Mode	15-05 Over Volt's	0 - 56 *0	16-5* Ref. & Feeds.	0 - 0x7fffff *0
[*][8] Variable-speed mode	15-06 Reset kWh Counter	15-99 Parameter Metadata	16-50 External Reference	0 - 0x7fffff *0
Output Filter	[*][0] Do not reset	0 - 9999 *0	-200 - 200 % *0 %	Ext. Status Word
No Filter	[1] Reset counter	16-0* Data Readouts	16-52 Feedback(Unit)	Ext. Status Word 2
Sine-Wave Filter	14-55 Output Filter	16-00 General Status	-4999 - 4999 ProcessCtrlUnit *0	Alarm Word 3
	[*][0] No Filter	0 - 65535 *0	ProcessCtrlUnit	0 - 0x7fffff *0
	[1] Sine-Wave Filter	16-01 Reference [Unit]	-200 - 200 *0	0 - 0x7fffff *0

16-98	Warning Word 3	0.01 - 10000 s *10000 s	*[0] No action	34-03	PCD 3 Write For Application	0 - 65535 *0	37-06	Pos. Ramp Down Time	50 - 100000 ms *5000 ms
18-5*	Data Readouts 2	21-23 Ext. 1 Differentiation Time	[1] Set MM to read only	34-04	PCD 4 Write For Application	0 - 65535 *0	37-07	Pos. Auto Brake Ctrl	[0] Disable
18-51	Memory Module Warming Reason	21-24 Ext. 1 Dif. Gain Limit	[2] Set MM to read write	34-05	PCD 5 Write For Application	0 - 65535 *0	*[1] Enable		
18-52	Memory Module ID	22-0* Appl. Functions	[0] No function	34-06	PCD 6 Write For Application	0 - 65535 *0	37-08	Pos. Hold Delay	0 - 10000 ms *0 ms
18-9*	PID Readouts	22-02 Miscellaneous CL Control Mode	[1] Erase MM	34-07	PCD 7 Write For Application	0 - 65535 *0	37-09	Pos. Coast Delay	0 - 1000 ms *200 ms
18-90	Process PID Error	*[0] Normal	31-47 Time Limit Function	34-08	PCD 8 Write For Application	0 - 65535 *0	37-10	Pos. Brake Delay	0 - 1000 ms *200 ms
18-91	Process PID Output	[1] Simplified	31-48 Time Limit Remaining Time	34-09	PCD 9 Write For Application	0 - 65535 *0	37-11	Pos. Brake Wear Limit	0 - 1000 ms *200 ms
18-92	Process PID Clamped Output	22-4* Sleep Mode	32-2** Motion Control Basic Settings	34-20	PCD 10 Write For Application	0 - 65535 *0	37-12	Pos. PID Anti Windup	0 - 1073741824 *0
18-93	Process PID Gain Scaled Output	22-40 Minimum Run Time	32-11* User Unit	34-21	PCD 1 Read For Application	0 - 65535 *0	37-13	Pos. PID Output Clamp	1 - 10000 *1000
21-1*	Ext. Closed Loop	22-41 Minimum Sleep Time	32-12 User Unit Denominator	34-22	PCD 2 Read For Application	0 - 65535 *0	37-14	Pos. Ctrl. Source	*[0] DI
21-0*	Ext. CL Autotuning	22-43 Wake-Up Speed [Hz]	32-6* PID	34-23	PCD 3 Read For Application	0 - 65535 *0	[1] FieldBus		
21-09	Extended PID Enable	0 - 100 % *10 %	32-67 Max. Tolerated Position Error	34-24	PCD 4 Read For Application	0 - 65535 *0	37-15	Pos. Direction Block	[1] No Blocking
*[0] Disabled		22-45 Setpoint Boost	1 - 2147483648 *2000000	34-25	PCD 5 Read For Application	0 - 65535 *0	37-17	Pos. Ctrl Fault Behaviour	*[0] Ramp Down&Brake
21-1*	Ext. CL 1 Ref./Fb.	-100 - 100 % *0 %	32-8* Velocity & Acceleration	34-26	PCD 6 Read For Application	0 - 65535 *0	[1] Brake Directly		
21-11	Ext. 1 Minimum Reference	22-46 Maximum Boost Time	32-80 Maximum Allowed Velocity	34-27	PCD 7 Read For Application	0 - 65535 *0	[2] No Fault		
*0 ExtPID1Unit		0 - 600 s *60 s	1 - 30000 RPM *1500 RPM	34-28	PCD 8 Read For Application	0 - 65535 *0	[1] Homing Needed		
21-12	Ext. 1 Maximum Reference	22-47 Sleep Speed [Hz]	32-81 Motion Ctrl Quick Stop Ramp	34-29	PCD 9 Read For Application	0 - 65535 *0	[2] Pos. HW Limit		
*999999999 - 999999999 ExtPID1Unit		0 - 4000 *0	33-0** Motion Control Adv. Settings	34-30	PCD 10 Read For Application	0 - 65535 *0	[3] Neg. HW Limit		
21-13	Ext. 1 Reference Source	22-48 Sleep Delay Time	33-0* Home Motion	34-5* Process Data			[4] Pos. SW Limit		
*[0] No function		0 - 3600 s *0 s	33-00 Homing Mode	34-50 Actual Position			[5] Neg. SW Limit		
[1] Analog Input 53		0 - 3600 s *0 s	[0] Not forced	34-56 Track Error			[7] Brake Wear Limit		
[2] Analog Input 54		22-6* Broken Belt Detection	[1] Forced manual homing	37-0** Application Settings			[8] Quick Stop		
[7] Frequency input 29		0 - 100 % *10 %	[2] Forced automated homing	37-0* Application Mode			[9] PID Error Too Big		
[8] Frequency input 33		*[0] Off	33-01 Home Offset	*[0] Drive mode			[12] Rev. Operation		
21-14	Ext. 1 Feedback Source	[1] Warning	33-02 Home Ramp Time	[2] Position Control			[13] Fwd. Operation		
*[0] No function		[2] Trip	-1073741824 - 1073741824 *0	37-1* Position Control			[20] Can not find home position		
[1] Analog Input 53		22-61 Broken Belt Torque	1 - 1000 ms *10 ms	*[0] Pos. Feedback Source			37-19	Pos. New Index	0 - 255 *0
[2] Analog Input 54		0 - 600 s *10 s	33-03 Homing Velocity	[0] 24V Encoder					
[3] Frequency input 29		30-2** Adv. Start Adjust	-1500 - 1500 RPM *100 RPM	37-02 Pos. Target					
[4] Frequency input 33		0 - 60 s *Size related	33-04 Homing Behaviour	-1073741824 - 1073741824 *0					
21-15	Ext. 1 Setpoint	30-20 High Starting Torque Time [s]	*[1] Reverse no index	37-03 Pos. Type					
*0 ExtPID1Unit		0 - 2000 s *0 s	[3] Forward no index	*[0] Absolute					
21-17	Ext. 1 Reference [Unit]	30-21 High Starting Torque Current [%]	33-4* Limit Handling	[1] Relative					
-999999999 - 999999999 ExtPID1Unit		0 - 60 s *Size related	33-41 Negative Software Limit	37-04 Pos. Velocity					
*0 ExtPID1Unit		0 - 2000 s *Size related	-1073741824 - 1073741824 *500000	1 - 30000 RPM *100 RPM					
*0 ExtPID1Unit		Off	-1073741824 - 1073741824 *500000	Pos. Ramp Up Time					
21-18	Ext. 1 Feedback [Unit]	30-22 Locked Rotor Protection	33-42 Positive Software Limit	50 - 100000 ms *5000 ms					
*0 ExtPID1Unit		[0] Off	-1073741824 - 1073741824 *500000						
-999999999 - 999999999 ExtPID1Unit		[1] On	33-43 Negative Software Limit Active						
*0 ExtPID1Unit		30-23 Locked Rotor Detection Time [s]	[0] Inactive						
-999999999 - 999999999 ExtPID1Unit		0.05 - 1 s *0.10 s	[1] Active						
*0 ExtPID1Unit		31-1** Special Option	33-44 Positive Software Limit Active						
21-19	Ext. 1 Output [%]	31-4* Memory Module	[0] Inactive						
0 - 100 % *0 %		31-40 Memory Module Function	[1] Active						
21-2*	Ext. CL 1 PID	[0] Disabled	33-47 Target Position Window						
21-20	Ext. 1 Normal/Inverse Control	*[1] Only Allow Download	1 - 10000 *512						
*[0] Normal		[2] Only Allow Upload							
[1] Inverse		[3] Allow Both Download And Upload	34-2** Motion Control Data Readouts						
21-21	Ext. 1 Proportional Gain	[0] MM Information	34-0* PCD Write Par.						
0 - 10 *0.01		31-41 MM Information	34-01 PCD 1 Write For Application						
21-22	Ext. 1 Integral Time	0 - 2 *0	0 - 65535 *0						
		31-42 Configure Memory Module Access	PCD 2 Write For Application						
			0 - 2 *0						

Index

A

Abbreviation.....	68
AC input.....	5, 19
AC mains.....	5, 19
AC waveform.....	5
Additional resource.....	4
Alarm log.....	30
AMA with T27 connected.....	44
Ambient condition.....	58
Approval and certification.....	6
Auto on.....	30, 35
Auxiliary equipment.....	23

B

Backplate.....	10
Branch circuit protection.....	62
Burst transient.....	14

C

Cable length.....	58
Cable routing.....	23
Cable size.....	17
Circuit breaker.....	23
Clearance requirement.....	10
Conduct.....	23
Control	
Characteristic.....	61
terminal.....	30, 51
Wiring.....	13, 20, 23
Control card	
+10 V DC output.....	61
Performance.....	61
RS485 serial communication.....	61
USB serial communication.....	61
Convention.....	68
Cooling.....	10
Cooling clearance.....	23
Cross-section.....	58
Customer relay.....	42

D

DC current.....	5
Default setting.....	32
Derating.....	58
Digital input.....	20
Discharge time.....	7

Disconnect switch.....	24
Disposal instruction.....	6

E

EMC.....	58
EMC-compliant installation.....	13
Encoder rotation.....	34
Energy efficiency.....	55, 56, 57
Energy efficiency class.....	58
External command.....	5
External controller.....	4

F

Fault	
log.....	30
Feedback.....	23
Floating delta.....	19
Fuse.....	13, 23, 62

G

Ground	
connection.....	23
wire.....	13
Grounded delta.....	19
Grounding.....	17, 19, 23, 24

H

Hand on.....	30
High voltage.....	7, 24
Horizontal mounting.....	11

I

IEC 61800-3.....	19, 58
Initialization	
Manual procedure.....	32
Procedure.....	32
Input	
Current.....	19
power.....	13
power wiring.....	23
voltage.....	24
Power.....	5, 19, 23, 24
Terminal.....	19, 24
Inputs	
Analog input.....	59
Digital input.....	59
Pulse input.....	60
Installation.....	23
Installation environment.....	10
Intended use.....	4

Interference isolation.....	23		
Isolated main.....	19		
J			
Jumper.....	20		
L			
Leakage current.....	8, 13		
Lifting.....	10		
Load sharing.....	7		
Local control.....	30		
M			
Main menu.....	28, 30		
Mains			
Supply (L1/N, L2/L, L3).....	57		
Supply data.....	55		
Voltage.....	30		
Maintenance.....	47		
Mechanical brake control.....	21		
Menu key.....	25, 30		
Menu structure.....	30		
Motor			
Current.....	5, 33		
Data.....	34		
cable.....	13, 17		
current.....	30		
data.....	32		
output.....	57		
power.....	13, 30		
thermal protection.....	6		
Protection.....	4		
Rotation.....	34		
Status.....	4		
Mounting.....	10, 23		
N			
Nameplate.....	9		
Navigation key.....	25, 30		
Numeric display.....	25		
O			
Open loop.....	61		
Operation key.....	25, 30		
Optional equipment.....	24		
Output current.....	60		
Output power wiring.....	23		
Outputs			
Analog output.....	60		
Digital output.....	60		
Overcurrent protection.....	13		
P			
PELV.....	46, 61		
Potential equalization.....	14		
Power connection.....	13		
Power factor.....	5, 23		
Programming.....	20, 30, 31		
Q			
Qualified personnel.....	7		
Quick menu.....	26, 30		
R			
Recycling.....	6		
Reference.....	30		
Relay output.....	61		
Remote command.....	4		
Reset.....	30, 32, 47		
RFI filter.....	19		
Run command.....	35		
S			
Safety.....	8		
Serial communication			
Serial communication.....	22, 30, 47, 61		
USB serial communication.....	61		
Service.....	47		
Set-up.....	35		
Shielded cable.....	23		
Shock.....	10		
Side-by-side installation.....	11		
SIL2.....	6		
SILCL of SIL2.....	6		
Specification.....	23		
Speed reference.....	35, 44		
Standard and compliance for STO.....	6		
Start-up.....	32		
STO			
Activation.....	41		
Automatic restart.....	41, 42		
Commissioning test.....	41		
Deactivation.....	41		
Maintenance.....	42		
Manual restart.....	41, 42		
Technical data.....	43		
Storage.....	10		
Supply voltage.....	24, 60		
Symbol.....	68		
System feedback.....	4		

T

Terminal tightening torque..... 62

Terminals

Control terminal..... 30, 51

Output terminal..... 24

Thermal protection..... 6

Thermistor..... 46

Torque

characteristic..... 58

Transient protection..... 5

U

Unintended start..... 7, 47

V

Vibration..... 10

Voltage level..... 59

W

Warning and alarm list..... 51

Wire size..... 13



.....
Danfoss can accept no responsibility for possible errors in catalogues, brochures and other printed material. Danfoss reserves the right to alter its products without notice. This also applies to products already on order provided that such alterations can be made without subsequential changes being necessary in specifications already agreed. All trademarks in this material are property of the respective companies. Danfoss and the Danfoss logotype are trademarks of Danfoss A/S. All rights reserved.
.....

Danfoss A/S
Ulsnaes 1
DK-6300 Graasten
vlt-drives.danfoss.com

