

Contents

1 Introduction	3
1.1.2 Copyright, Limitation of Liability and Revision Rights	4
1.1.6 Type Code String	6
2 Safety	7
2.1.2 High Voltage Warning	7
2.1.5 Before Commencing Repair Work	8
2.1.6 Special Conditions	9
2.1.7 Safe Stop of the Frequency Converter	9
2.1.8 IT Mains	11
3 Application Guide	12
3.1.1 ADAP-KOOL® Drive Application Guide	12
3.1.2 Application Descriptions	17
4 Mechanical Installation	19
4.1 Before starting	19
4.1.2 Mechanical Dimensions	20
4.2 How to Install	23
5 Electrical Installation	25
5.1 How to Connect	25
5.1.2 Electrical Installation and Control Cables	26
5.1.5 Mains Wiring Overview	30
5.1.11 Motor Wiring Overview	36
5.1.19 How to Test Motor and Direction of Rotation	41
6 How to Operate the Frequency Converter	45
6.1.2 How to Operate the Graphical LCP (GLCP)	45
6.1.6 Tips and Tricks	52
7 How to Programme the Frequency Converter	54
7.1 How to Programme	54
7.2 Parameter list	80
7.2.1 0-** Operation and Display	81
7.2.2 1-** Load / Motor	83
7.2.3 2-** Brakes	84
7.2.4 3-** Reference / Ramps	85
7.2.5 4-** Limits / Warnings	86
7.2.6 5-** Digital In / Out	87
7.2.7 6-** Analog In / Out	89

7.2.8 8-** Communication and Options	91
7.2.9 11-** ADAP-KOOL LON	92
7.2.10 13-** Smart Logic Controller	93
7.2.11 14-** Special Functions	94
7.2.12 15-** FC Information	95
7.2.13 16-** Data Readouts	97
7.2.14 18-** Info & Readouts	99
7.2.15 20-** FC Closed Loop	100
7.2.16 21-** Ext. Closed Loop	101
7.2.17 22-** Application Functions	103
7.2.18 23-** Time Based Functions	105
7.2.19 25-** Pack Controller	106
7.2.20 26-** Analog I / O Option MCB 109	107
7.2.21 28-** Compressor Functions	108
8 Troubleshooting	109
8.1.1 Warning/Alarm list	112
9 Specifications	116
9.1 General Specifications	116
9.2 Special Conditions	124
Index	128

1 Introduction

1.1 Introduction

The AKD 102 ADAP-KOOL Drive from Danfoss Food Retail has been designed with our refrigeration customers clearly in mind. The drive is designed to make commissioning and installation a simple and easy task. The built in “wizard” set up menu guides the installer through the set up of the drive in a clear and structured manner, and has been constructed with reference to the industries refrigeration engineers, to ensure that the text and language used makes complete sense to the installer.



The AKD 102 drive comes with a common user interface which covers all power ratings between 1.1- 250 kW. Thus ensuring that once you have learnt how to commission one drive you understand how to commission them all. Included on this local control panel is an “info” button which is essentially a built in drive instruction manual which help the user to both gain information and also suggests other parameters which may need to be changed. The AKD 102 also features a built in “pack controller” controlled via the drives own standard software. This allows the drive to control the lead compressor via variable speed and the bringing on line of another 2 compressors in fixed speed mode. This leads to extremely efficient pack design which also adds the energy efficiency of variable speed control. Using the drive in this way eliminates the need for an external pack controller thus giving financial savings to the customer.

The drive can be supplied in either of two protection classes IP21(IP20 up to 7,5kW) or IP55 (IP66 on request); this insures that our customers benefit from having the most robust of designs supplied directly from the factory, without the need for additional cabinets in which to house the drive. The AKD also benefits from the inclusion of having built in RFI filters as standard which means that the problems associated with radio interference and long cable runs are no problem for our customers.

The modular construction of the AKD means that you only have to pay for what you need. Each AKD is manufactured only when we receive a customer order and so is built exactly to customer specification with any chosen options added at this stage. But by using this manufacturing and design philosophy it means that should options such as ADAP-KOOL Lon be required at some future date they are a simple retrofit inside of the drive which can be done by anyone with extreme ease. Warranty: Each AKD comes with 18 months warranty from date of manufacture or 12 months from date of documented installation, whichever comes first thus ensuring that our Food Retail customers have complete peace of mind when choosing AKD as their drive of choice.

1.1.1 Software Version and Approvals: ADAP-KOOL® Drive

ADAP-KOOL® Drive
Operating Instructions
Software version: 2.xx

This Operating Instructions can be used for all ADAP-KOOL® Drive frequency converters with software version 2.xx.
 The software version number can be seen from parameter 15-43.

1.1.2 Copyright, Limitation of Liability and Revision Rights

This publication contains information proprietary to Danfoss. By accepting and using this manual the user agrees that the information contained herein will be used solely for operating equipment from Danfoss or equipment from other vendors provided that such equipment is intended for communication with Danfoss equipment over a serial communication link. This publication is protected under the Copyright laws of Denmark and most other countries.

Danfoss does not warrant that a software program produced according to the guidelines provided in this manual will function properly in every physical, hardware or software environment.

Although Danfoss has tested and reviewed the documentation within this manual, Danfoss makes no warranty or representation, neither expressed nor implied, with respect to this documentation, including its quality, performance, or fitness for a particular purpose.

In no event shall Danfoss be liable for direct, indirect, special, incidental, or consequential damages arising out of the use, or the inability to use information contained in this manual, even if advised of the possibility of such damages. In particular, Danfoss is not responsible for any costs, including but not limited to those incurred as a result of lost profits or revenue, loss or damage of equipment, loss of computer programs, loss of data, the costs to substitute these, or any claims by third parties.

Danfoss reserves the right to revise this publication at any time and to make changes to its contents without prior notice or any obligation to notify former or present users of such revisions or changes.

1.1.3 Available Literature

- Operating Instructions MG.11.Lx.yy provide the necessary information for getting the drive up and running.
- Design Guide MG.11.Mx.yy entails all technical information about the drive and customer design and applications.
- Programming Guide MG.11.Nx.yy provides information on how to programme and includes complete parameter descriptions.
- Operating Instructions AKD102 High Power, MG.11.Ox.yy
- Operating Instructions AKD LonWorks, MG.11.Px.yy

x = Revision number

yy = Language code

Danfoss Drives technical literature is also available online at www.danfoss.com/BusinessAreas/DrivesSolutions/Documentations/Technical+Documentation.htm.

1.1.4 Abbreviations and Standards

Abbreviations:	Terms:	SI-units:	I-P units:
a	Acceleration	m/s ²	ft/s ²
AWG	American wire gauge		
Auto Tune	Automatic Motor Tuning		
°C	Celsius		
I	Current	A	Amp
I _{LIM}	Current limit		
Joule	Energy	J = N·m	ft-lb, Btu
°F	Fahrenheit		
FC	Frequency Converter		
f	Frequency	Hz	Hz
kHz	Kilohertz	kHz	kHz
LCP	Local Control Panel		
mA	Milliampere		
ms	Millisecond		
min	Minute		
MCT	Motion Control Tool		
M-TYPE	Motor Type Dependent		
Nm	Newton Metres		in-lbs
I _{M,N}	Nominal motor current		
f _{M,N}	Nominal motor frequency		
P _{M,N}	Nominal motor power		
U _{M,N}	Nominal motor voltage		
par.	Parameter		
PELV	Protective Extra Low Voltage		
Watt	Power	W	Btu/hr, hp
Pascal	Pressure	Pa = N/m ²	psi, psf, ft of water
I _{INV}	Rated Inverter Output Current		
RPM	Revolutions Per Minute		
SR	Size Related		
T	Temperature	C	F
t	Time	s	s,hr
T _{LIM}	Torque limit		
U	Voltage	V	V

Table 1.1 Abbreviation and standards table.

1.1.5 Frequency Converter Identification

Below is an example of an identification label. This label is situated on the frequency converter and shows the type and options fitted to the unit. See table 2.1 for details of how to read the Type code string (T/C).



130BA887.10

Illustration 1.1 This example shows an identification label.

NOTE

Please have T/C (type code) number and serial number ready before contacting Danfoss.

1.1.6 Type Code String

1 2 3 4 5 6 7 8 9 10 11 12 13 14 15 16 17 18 19 20 21 22 23 24 25 26 27 28 29 30 31 32 33 34 35 36 37 38 39
 AKD- 0 P T H X X S X X X X A B C D
130BA859.10

Description	Pos	Possible choice
Product group & VLT Series	1-6	AKD102
Power rating	8-10	1.1 - 250 kW (P1K1 - P250)
Number of phases	11	Three phases (T)
Mains voltage	11-12	T 2: 200-240 VAC T 4: 380-480 VAC
Enclosure	13-15	E20: IP20 E21: IP 21/NEMA Type 1 E55: IP 55/NEMA Type 12 E66: IP66 P21: IP21/NEMA Type 1 w/backplate P55: IP55/NEMA Type 12 w/backplate
RFI filter	16-17	H1: RFI filter class A1/B H2: RFI filter class A2 H4: RFI filter class A2/A1
Display	19	G: Graphical Local Control Panel (GLCP) X: No Local Control Panel
Coating PCB	20	C: Coated PCB
Mains option	21	X: No Mains disconnect switch 1: With Mains disconnect switch (IP55 only)
Adaptation	22	Reserved
Adaptation	23	Reserved
Software release	24-27	Actual software
Software language	28	
A options	29-30	AX: No options AZ: MCA 107AKD LonWorks
B options	31-32	BX: No option BK: MCB 101 General purpose I/O option BP: MCB 105 Relay option BO: MCB 109 Analog I/O option
C0 options MCO	33-34	CX: No options
C1 options	35	X: No options
C option software	36-37	XX: Standard software
D options	38-39	DX: No option D0: DC back-up MCB107

Table 1.2 Type code description.

The various options are described further in the ADAP-KOOL® Drive AKD102 Design Guide, MG.11.Mx.yy.

2 Safety

2.1.1 Symbols

Symbols used in this manual:

NOTE

Indicates something to be noted by the reader.



Indicates a general warning.



Indicates a high-voltage warning.



Indicates default setting

2.1.2 High Voltage Warning



The voltage of the frequency converter and the MCO 101 option card is dangerous whenever it is connected to mains. Incorrect installation of the motor or frequency converter may causedeath, serious injury or damage to the equipment. Consequently, it is essential to comply with the instructions in this manual as well as local and national rules and safety regulations.

2.1.3 Safety Note



The voltage of the frequency converter is dangerous whenever connected to mains. Incorrect installation of the motor, frequency converter or fieldbus may cause death, serious personal injury or damage to the equipment. Consequently, the instructions in this manual, as well as national and local rules and safety regulations, must be complied with.

Safety Regulations

1. The frequency converter must be disconnected from mains if repair work is to be carried out. Check that the mains supply has been disconnected and that the necessary time has passed before removing motor and mains plugs.
2. The [STOP/RESET] key on the LCP of the frequency converter does not disconnect the equipment from mains and is thus not to be used as a safety switch.
3. Correct protective earthing of the equipment must be established, the user must be protected against supply voltage, and the motor must be protected against overload in accordance with applicable national and local regulations.
4. The earth leakage currents are higher than 3.5 mA.
5. Protection against motor overload is set by *1-90 Motor Thermal Protection*. If this function is desired, set *1-90 Motor Thermal Protection* to data value [ETR trip] (default value) or data value [ETR warning]. Note: The function is initialized at 1.16 x rated motor current and rated motor frequency. For the North American market: The ETR functions provide class 20 motor overload protection in accordance with NEC.
6. Do not remove the plugs for the motor and mains supply while the frequency converter is connected to mains. Check that the mains supply has been disconnected and that the necessary time has passed before removing motor and mains plugs.

- Please note that the frequency converter has more voltage inputs than L1, L2 and L3, when load sharing (linking of DC intermediate circuit) and external 24 V DC have been installed. Check that all voltage inputs have been disconnected and that the necessary time has passed before commencing repair work.

Installation at high altitudes



Installation at high altitude:

380 - 500 V, enclosure A, B and C: At altitudes above 2 km, please contact Danfoss regarding PELV.

380 - 500 V, enclosure D, E and F: At altitudes above 3 km, please contact Danfoss regarding PELV.



Warning against Unintended Start

- The motor can be brought to a stop by means of digital commands, bus commands, references or a local stop, while the frequency converter is connected to mains. If personal safety considerations make it necessary to ensure that no unintended start occurs, these stop functions are not sufficient.
- While parameters are being changed, the motor may start. Consequently, the stop key [STOP/RESET] must always be activated; following which data can be modified.
- A motor that has been stopped may start if faults occur in the electronics of the frequency converter, or if a temporary overload or a fault in the supply mains or the motor connection ceases.



Touching the electrical parts may be fatal - even after the equipment has been disconnected from mains.

Also make sure that other voltage inputs have been disconnected, such as external 24 V DC, load sharing (linkage of DC intermediate circuit), as well as the motor connection for kinetic back up. Refer to the Operating Instructions for further safety guidelines.

2.1.4 Caution



The frequency converter DC link capacitors remain charged after power has been disconnected. To avoid an electrical shock hazard, disconnect the frequency converter from the mains before carrying out maintenance. Wait at least as follows before doing service on the frequency converter:

Voltage	Minimum Waiting Time	
	4 min.	15 min.
200 - 240 V	1.1 - 3.7 kW	5.5 - 45 kW
380 - 480 V	1.1 - 7.5 kW	11 - 90 kW

Be aware that there may be high voltage on the DC link even when the LEDs are turned off.

2.1.5 Before Commencing Repair Work

- Disconnect the frequency converter from mains
- Disconnect DC bus terminals 88 and 89
- Wait at least the time mentioned in section General Warning above
- Remove motor cable

2.1.6 Special Conditions

Electrical ratings:

The rating indicated on the nameplate (Illustration 2.1) of the frequency converter is based on a typical 3-phase mains power supply, within the specified voltage, current and temperature range, which is expected to be used in most applications.

The frequency converters also support other special applications, which affect the electrical ratings of the frequency converter.

Special conditions which affect the electrical ratings might be:

- Single phase applications
- High temperature applications which require de-rating of the electrical ratings
- Marine applications with more severe environmental conditions.

Other applications might also affect the electrical ratings.

Consult the relevant clauses in these instructions and in the *AKD102 Design Guide, MG.11.Mx.yy* for information about the electrical ratings.

Installation requirements:

The overall electrical safety of the frequency converter requires special installation considerations regarding:

- Fuses and circuit breakers for over-current and short-circuit protection
- Selection of power cables (mains, motor, brake, loadsharing and relay)
- Grid configuration (IT,TN, grounded leg, etc.)
- Safety of low-voltage ports (PELV conditions).

Consult the relevant clauses in these instructions and in the *AKD102 Design Guide* for information about the installation requirements.

2.1.7 Safe Stop of the Frequency Converter

For versions fitted with a Safe Stop terminal 37 input, the frequency converter can perform the safety function *Safe Torque Off* (As defined by draft CD IEC 61800-5-2) or *Stop Category 0* (as defined in EN 60204-1).

It is designed and approved suitable for the requirements of Safety Category 3 in EN 954-1. This functionality is called Safe Stop. Prior to integration and use of Safe Stop in an installation, a thorough risk analysis on the installation must be carried out in order to determine whether the Safe Stop functionality and safety category are appropriate and sufficient. In order to install and use the Safe Stop function in accordance with the requirements of Safety Category 3 in EN 954-1, the related information and instructions of the *AKD102 Design Guide MG.11.MX.YY* must be followed! The information and instructions of the Operating Instructions are not sufficient for a correct and safe use of the Safe Stop functionality!

Prüf- und Zertifizierungsstelle
im BG-PRÜFZERT



BGIA
Berufsgenossenschaftliches
Institut für Arbeitsschutz

Hauptverband der gewerblichen
Berufsgenossenschaften

Translation

In any case, the German
original shall prevail.

Type Test Certificate

05 06004

No. of certificate

Name and address of the
holder of the certificate:
(customer) Danfoss Drives A/S, Ulnaes 1
DK-6300 Graasten, Dänemark

Name and address of the
manufacturer: Danfoss Drives A/S, Ulnaes 1
DK-6300 Graasten, Dänemark

Ref. of customer:

Ref. of Test and Certification Body:
Apf/Köh VE-Nr. 2003 23220

Date of Issue:
13.04.2005

Product designation: Frequency converter with integrated safety functions

Type: VLT® Automation Drive FC 302

Intended purpose: Implementation of safety function „Safe Stop“

Testing based on: EN 954-1, 1997-03,
DKE AK 226.03, 1998-06,
EN ISO 13849-2; 2003-12,
EN 61800-3, 2001-02,
EN 61800-5-1, 2003-09,

Test certificate: No.: 2003 23220 from 13.04.2005

Remarks: The presented types of the frequency converter FC 302 meet the requirements laid down in the test bases.
With correct wiring a category 3 according to DIN EN 954-1 is reached for the safety function.

The type tested complies with the provisions laid down in the directive 98/37/EC (Machinery).

Further conditions are laid down in the Rules of Procedure for Testing and Certification of April 2004.

Head of certification body

(Prof. Dr. rer. nat. Dietmar Reinert)

Certification officer

(Dipl.-Ing. R. Apfeld)

PZB10E
01.05



Postal address:
53754 Sankt Augustin

Office:
Alte Heerstraße 111
53757 Sankt Augustin

Phone: 0 22 41/2 31-02
Fax: 0 22 41/2 31-22 34

130BA491

Illustration 2.1 This certificate also covers AKD102

2.1.8 IT Mains

⚠ WARNING

IT mains

Do not connect frequency converters with RFI-filters to mains supplies with a voltage between phase and earth of more than 440 V for 400 V converters and 760 V for 690 V converters.

For 400 V IT mains and delta earth (grounded leg), mains voltage may exceed 440 V between phase and earth.

For 690 V IT mains and delta earth (grounded leg), mains voltage may exceed 760 V between phase and earth.

14-50 RFI Filter can be used to disconnect the internal RFI capacitors from the RFI filter to ground.

2.1.9 Disposal Instruction



Equipment containing electrical components must not be disposed of together with domestic waste. It must be separately collected with electrical and electronic waste according to local and currently valid legislation.

3 Application Guide

3

3.1.1 ADAP-KOOL® Drive Application Guide

The built in “wizard” menu guides the installer through the set up of the drive in a clear and structured manner, and has been constructed with reference to the industries refrigeration engineers, to ensure that the text and language used makes complete sense to the installer.

The ADAP-KOOL Drive AKD 102 will initially start up with the Application guide (each time until it has been run), thereafter in the event of power failure the application guide is accessed through the Quick menu screen.

If “Cancel” is pressed, the AKD 102 will return to the status screen. An automatic timer will cancel the wizard after 5 min. of inactivity (no buttons pressed). The wizard must be re-entered through the Quick Menu when it has been run once.

Answering the questions on the screens will take the user though a complete setup for the ADAP-KOOL Drive. Most standard refrigeration applications can be setup by using this Application Guide. Advanced features must be accessed though the menu structure (Quick Menu or Main Menu) in the drive.

The Application guide covers all standard settings for:

- Compressors
- Single fan and pump
- Condenser fans

After completing setup, choose to re-run wizard or start application

The Application Guide can be cancelled at any time by pressing “Back”. The Application Guide can be re-entered through the Quick Menu. When re-entering the Application Guide, the user will be asked to keep previous changes to the factory setup or to restore default values.

The ADAP-KOOL Drive AKD 102 will start up initially with the Application guide thereafter in the event of power failure the application guide is accessed through the Quick menu screen.

The following screen will be presented:



If “Cancel” is pressed, the AKD 102 will return to the status screen. An automatic timer will cancel the wizard after 5 min. of inactivity (no buttons pressed). The wizard must be re-entered through the Quick Menu as described below. If “OK” is pressed, the Application Guide will start with the following screen:



This screen will automatically change to the first input screen of the Application Guide:



Answering the questions on the screens will take the user through a complete setup for the ADAP-KOOL Drive. Most standard refrigeration applications can be setup by using this Application Guide. Advanced features must be accessed through the menu structure (Quick Menu, Main Menu etc.) in the drive.

The Application guide covers all standard settings for:

- Compressors
- Single fan and pump
- Condenser fans



130BA757.10

Compressor pack setup

As an example, please see screens below for a compressor pack setup:

Voltage and frequency setup

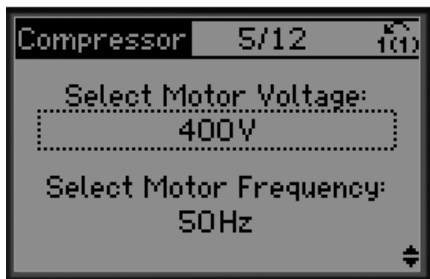

130BA788.10

Current and nominal speed setup

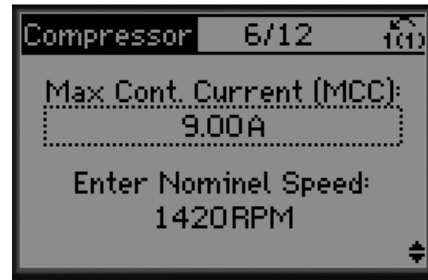

130BA789.10

Min. and max. frequency setup



130BA790.10

Min. time between two starts



130BA791.10

3

Choose with/ without bypass valve

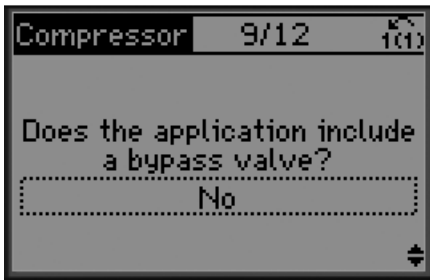

130BA792.10

Settings for sensor



130BA795.10

Select open or closed loop

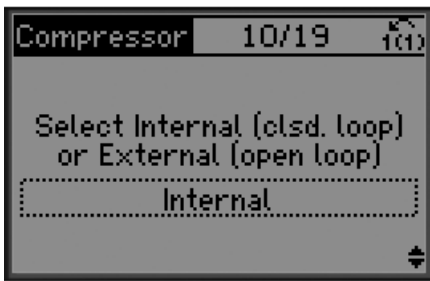

130BA793.10

Info: 4-20 mA feedback chosen - please connect accordingly



130BA796.10

NOTE

Internal / Closed loop : The AKD 102 will control the application directly using the internal PID control within the drive and needs an input from an external input such as a temperature or other sensor which is wired directly into the drive and controls from the sensor signal.

External / Open loop: The AKD 102 takes its control signal from another controller (such as a pack controller) which gives the drive e.g. 0-10v, 4-20 mA or ADAP-KOOL Lon. The drive will change its speed depending upon this reference signal.

Info: Set switch accordingly



130BA797.10

Select sensor type

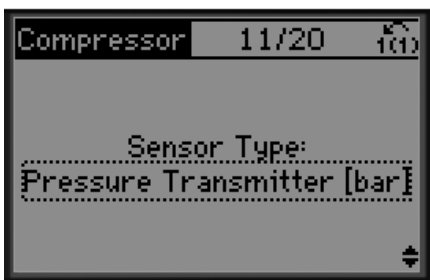

130BA794.10

Select unit and conversion from pressure



130BA798.10

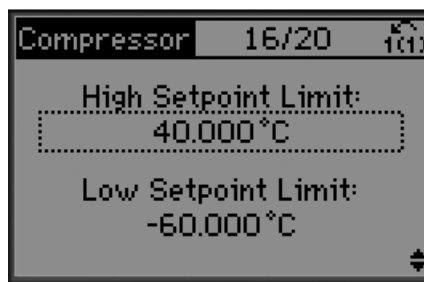

130BA801.10

Set cut out/ in value

Select fixed or floating setpoint

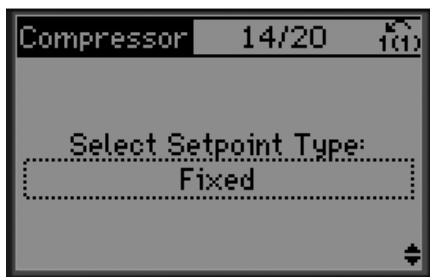

130BA799.10

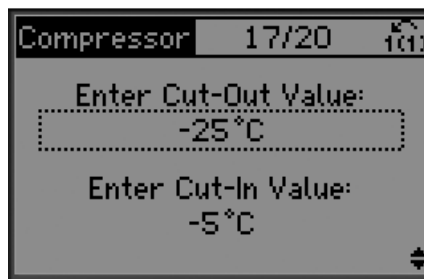

130BA802.10

Choose pack control setup

Set setpoint

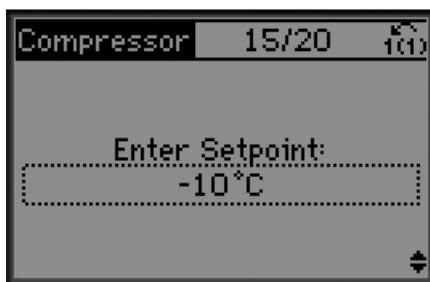

130BA800.10

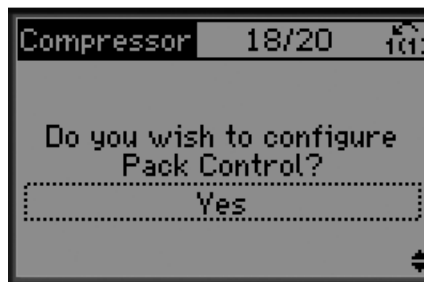

130BA803.10

Set number of compressors in pack

Set high/ low limit for setpoint

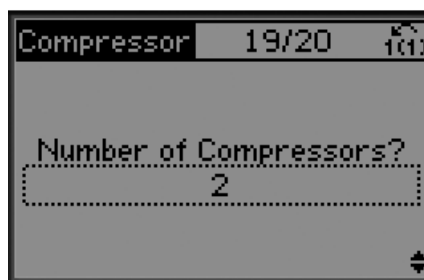

130BA804.10

Info: Connect accordingly

3



130BA805.10

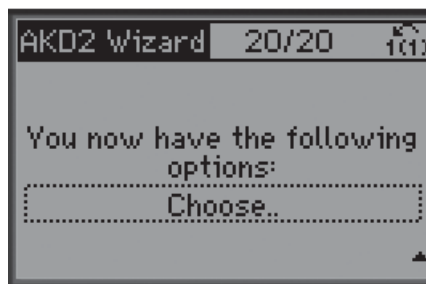

130BA787.10

Info: Setup completed



130BA806.10



130BA758.10

After completing setup, choose to re-run wizard or start application. Here we can select the following options:

- Re-run wizard
- Go to main menu
- Go to status
- Run AMA - Note this is a reduced AMA if compressor application is selected and full AMA if single fan and pump is selected.
- If condenser fan is selected in application NO AMA can be run.
- Run application- this mode starts the drive in either hand / local mode or via an external control signal if open loop is selected in an earlier screen

The Application Guide can be cancelled at any time by pressing "Back". The Application Guide can be re-entered through the Quick Menu:

When re-entering the Application Guide, the user will be asked to keep previous changes to the factory setup or to restore default values.

NOTE

If the system requirement is to have the internal pack controller for 3 compressors plus by-pass valve connected, there is the need to specify AKD 102 with the extra relay card (MCB105) mounted inside the drive.

The bypass valve must be programmed to operate from one of the extra relay outputs on the MCB105 board. This is needed because the standard relay outputs in the AKD 102 are used to control the compressors in the pack.

3.1.2 Application Descriptions

The AKD Wizard is structured into three basic applications:

- Compressor
- Multi condenser fan
- Single fan and pump

These applications are then further expanded to allow control of the drive to be controlled via the drives own internal PID controllers or from an external control signal.

Compressor

The wizard guides the user through the set up of a refrigeration compressor by asking him to input data about the compressor and the refrigeration system on which the drive will be running. All terminology and units used within the wizard are common refrigeration type and set up is thus completed in 10-15 easy steps using just two buttons of the drives local control panel.

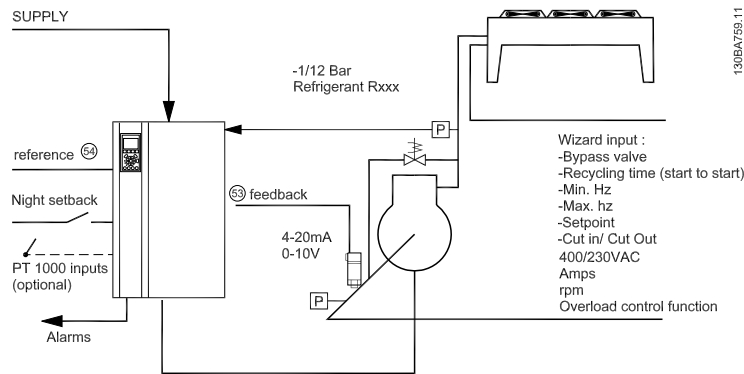

Illustration 3.1 Standard drawing of "Compressor with internal control"

Single or multiple fans or pumps

The wizard guides the user through the set up of a refrigeration condenser fan or pump by asking him to input data about the condenser or pump and the refrigeration system on which the drive will be running. All terminology and units used within the wizard are common refrigeration type and set up is thus completed in 10-15 easy steps using just two buttons of the drives local control panel.

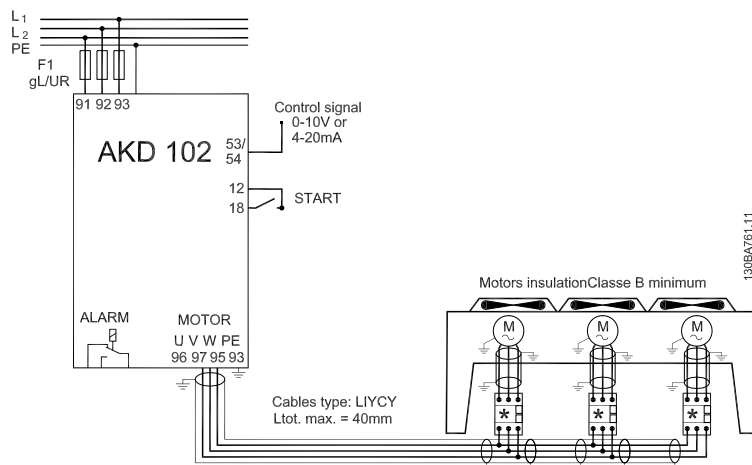

Illustration 3.2 Speed control using analogue reference (open loop) – single fan or pump / multiple fans or pumps in parallel

3

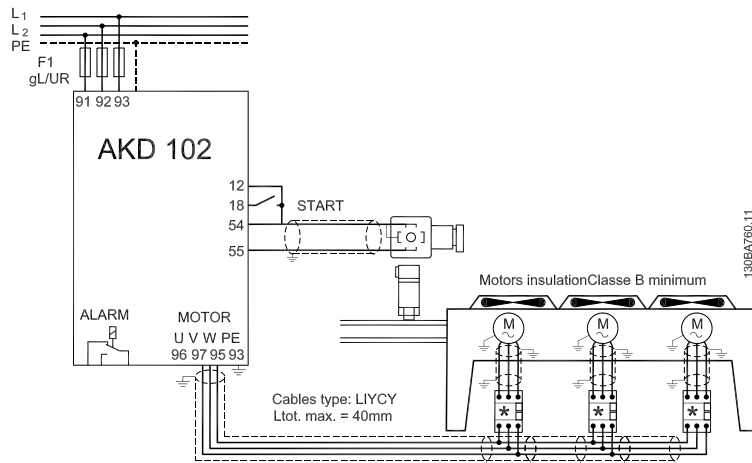

Illustration 3.3 Pressure control in closed loop – stand alone system. single fan or pump / multiple fans or pumps in parallel

Compressor pack

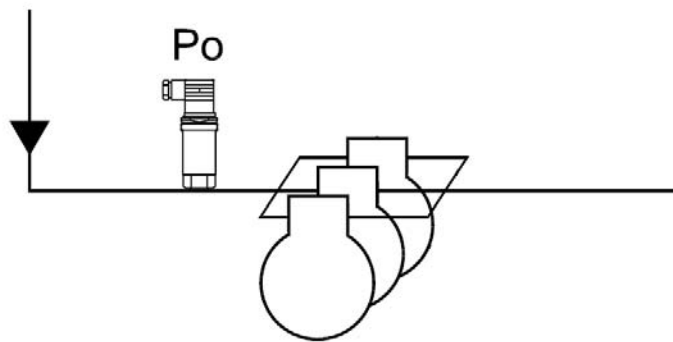

Illustration 3.4 P_0 pressure transmitter

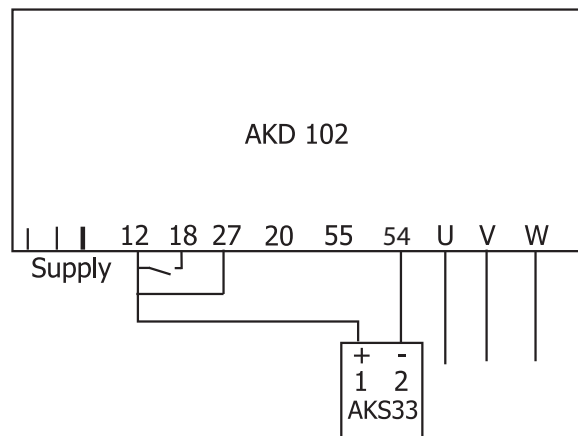

Illustration 3.5 How to connect the AKD102 and AKS33 for closed loop applications

4 Mechanical Installation

4.1 Before starting

4.1.1 Checklist

When unpacking the frequency converter, ensure that the unit is undamaged and complete. Use the following table to identify the packaging:

Enclosure type:	A2 (IP 20-21)	A3 (IP 20-21)	A4/A5 (IP 55-66)	B1 (IP 21-55-66)	B2 (IP 21-55-66)	C1 (IP 21-55-66)	C2 (IP 21-55-66)
Unit size (kW):							
200-240 V	1.1-3.0	3.7	1.1-3.7	5.5-11/ 5.5-11	15/ 15-18.5	18.5-30/ 22-30	37-45/ 37-45
380-480 V	1.1-4.0	5.5-7.5	1.1-7.5	11-18.5/ 11-18.5	22-30/ 22-37	37-55/ 45-55	75-90/ 75-90

Table 4.1 Unpacking table

Please note that a selection of screwdrivers (phillips or cross-thread screwdriver and torx), a side-cutter, drill and knife is also recommended to have handy for unpacking and mounting the frequency converter. The packaging for these enclosures contains, as shown: Accessories bag(s), documentation and the unit. Depending on options fitted there may be one or two bags and one or more booklets.

4.1.2 Mechanical Dimensions

4

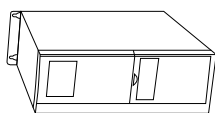
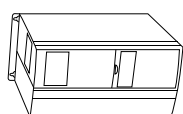
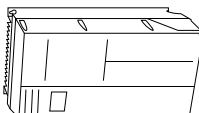
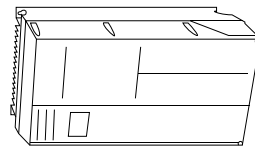
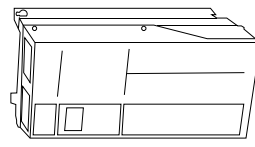
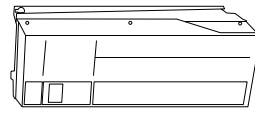
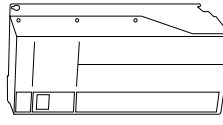
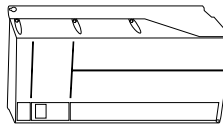
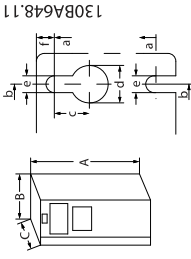
A2		130BA809.10	IP20/21
A3		130BA810.10	IP20/21
A4		130BA811.10	IP55/66
A5		130BA811.10	IP55/66
B1		130BA812.10	IP21/55/66
B2		130BA813.10	IP21/55/66
C1		130BA814.10	IP21/55/66
C2		130BA815.10	IP21/55/66
			
<p>All measurements in mm. * A5 in IP55/66 only</p>			



Mechanical dimensions										
Frame size (kW):	A2	A3	A4	A5	B1	B2	C1	C2		
200-240 V	1.1-3.0	3.7	1.1-2.2	1.1-3.7	5.5-11	15	18.5-30	37-45		
380-480 V	1.1-4.0	5.5-7.5	1.1-4.0	1.1-7.5	11-18.5	22-30	37-55	75-90		
IP	20	20	21	55/66	21/ 55/66	21/55/66	21/55/66	21/55/66		
NEMA	Chassis	Chassis	Type 1	Type 1,2	Type 1/12	Type 1/12	Type 1/12	Type 1/12		
Height (mm)										
Enclosure	A**	246	372	390	480	650	680	770		
...with de-coupling plate	A2	374	-	-	-	-	-	-		
Back plate	A1	268	375	390	480	650	680	770		
Distance between mount. holes	a	257	350	401	454	624	648	739		
Width (mm)										
Enclosure	B	90	130	200	242	242	308	370		
With one C option	B	130	170	200	242	242	308	370		
Back plate	B	90	130	200	242	242	308	370		
Distance between mount. holes	b	70	110	171	215	210	272	334		
Depth (mm)										
Without option A/B	C	205	205	175	200	260	310	335		
With option A/B	C*	220	220	175	200	260	310	335		
Screw holes (mm)										
	c	8.0	8.0	8.2	8.2	12	12	12		
Diameter ø	d	11	11	12	12	19	19	19		
Diameter ø	e	5.5	5.5	6.5	6.5	9	9.0	9.0		
	f	9	9	6	9	9	9.8	9.8		
Max weight (kg)		4.9	5.3	9.7	14	23	45	65		

* Depth of enclosure will vary with different options installed.

** The free space requirements are above and below the bare enclosure height measurement A. See section 3.2.3 for further information.

4.1.3 Accessory Bags

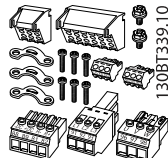
Accessory Bags: Find the following parts included in the frequency converter accessory bags

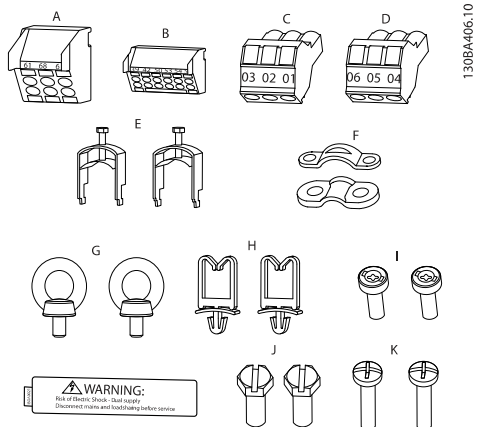
 <p>130BT309.10</p> <p>Frame sizes A2 and A3</p>	 <p>130BT339.10</p> <p>Frame size A4/A5</p>
 <p>130BT330.10</p> <p>Frame sizes B1 and B2</p>	 <p>A B C D E F G H I J K</p> <p>130BA406.10</p> <p>Frame sizes C1 and C2</p> <p>WARNING: Risk of Electric Shock - Dead Capacity Disconnect frame and footlocking before service.</p>

1 + 2 only available in units with brake chopper. For DC link connection (Load sharing) the connector 1 can be ordered separately. An eight pole connector is included in accessory bag for AKD 102 without Safe Stop.

4

4.2 How to Install

4.2.1 Mechanical Mounting

All IP20 enclosure sizes as well as IP21/ IP55 enclosure sizes except A2 and A3 allow side-by-side installation.

If the IP 21 Enclosure kit (130B1122 or 130B1123) is used on enclosure A2 or A3, there must be a clearance between the drives of min. 50 mm.

For optimal cooling conditions allow a free air passage above and below the frequency converter. See table below.

Air passage for different enclosures

Enclosure:	A2	A3	A4	A5	B1	B2	C1	C2
a (mm):	100	100	100	100	200	200	200	225
b (mm):	100	100	100	100	200	200	200	225

1. Drill holes in accordance with the measurements given.
2. You must provide screws suitable for the surface on which you want to mount the frequency converter. Re-tighten all four screws.

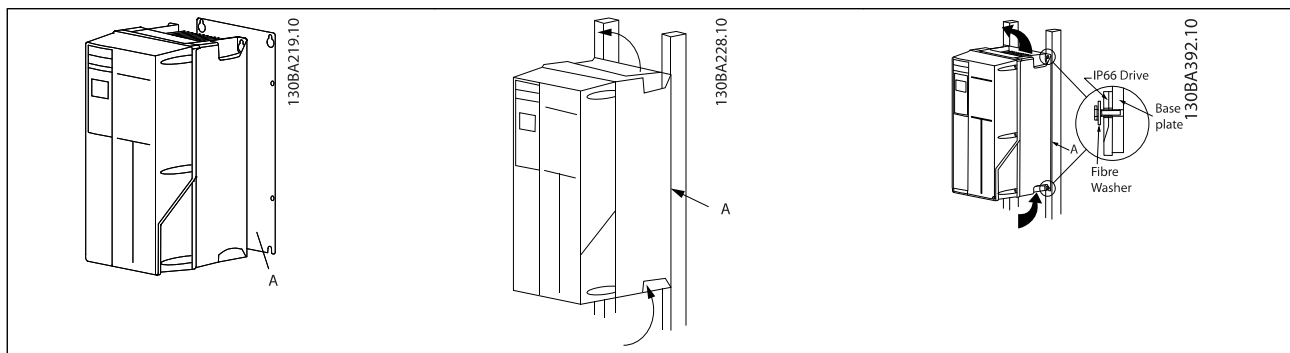

Table 4.2 Mounting frame sizes A5, B1, B2, C1 and C2 on a non-solid back wall, the drive must be provided with a back plate A due to insufficient cooling air over the heat sink.

4.2.2 Safety Requirements of Mechanical Installation

⚠ WARNING

Pay attention to the requirements that apply to integration and field mounting kit. Observe the information in the list to avoid serious injury or equipment damage, especially when installing large units.

NOTE

The frequency converter is cooled by means of air circulation.

To protect the unit from overheating, it must be ensured that the ambient temperature *does not exceed the maximum temperature stated for the frequency converter* and that the 24-hour average temperature *is not exceeded*. Locate the maximum temperature and 24-hour average in the paragraph *Derating for Ambient Temperature*.

If the ambient temperature is in the range of 45 °C - 55 °C, derating of the frequency converter will become relevant, see *Derating for Ambient Temperature*.

The service life of the frequency converter is reduced if derating for ambient temperature is not taken into account.

4.2.3 Field Mounting

For field mounting the IP 21/IP 4X top/TYPE 1 kits or IP 54/55 units are recommended.

4.2.4 Panel Through Mounting

A Panel Through Mount Kit is available for frequency converter series ADAP-KOOL Drive.

In order to increase heatsink cooling and reduce panel depth, the frequency converter may be mounted in a through panel. Furthermore the in-built fan can then be removed.

The kit is available for enclosures A5 through C2.

NOTE

This kit cannot be used with cast front covers. No cover or IP21 plastic cover must be used instead.

Information on ordering numbers is found in the *Design Guide*, section *Ordering Numbers*.

More detailed information is available in the *Panel Through Mount Kit instruction*, MI.33.H1.YY, where yy=language code.

5 Electrical Installation

5.1 How to Connect

5.1.1 Cables General

NOTE

For the AKDHigh Power series mains and motor connections, please see the ADAP-KOOL® Drive AKD102High Power Operating Instructions, MG.11.Ox.yy.

NOTE

Cables General

Always comply with national and local regulations on cable cross-sections.

5

Details of terminal tightening torques.

Enclo- sure	Power (kW)		Torque (Nm)					
	200-240 V	380-480 V	Line	Motor	DC connection	Brake	Earth	Relay
A2	1.1 - 3.0	1.1 - 4.0	1.8	1.8	1.8	1.8	3	0.6
A3	3.7	5.5 - 7.5	1.8	1.8	1.8	1.8	3	0.6
A4	1.1 - 2.2	1.4 - 4	1.8	1.8	1.8	1.8	3	0.6
A5	1.1 - 3.7	1.1 - 7.5	1.8	1.8	1.8	1.8	3	0.6
B1	5.5 - 11	11 - 18.5	1.8	1.8	1.5	1.5	3	0.6
B2	-	22	2.5	2.5	3.7	3.7	3	0.6
	15	30	4.5	4.5	3.7	3.7	3	0.6
C1	18.5 - 30	37 - 55	10	10	10	10	3	0.6
C2	37	75	14	14	14	14	3	0.6
	45	90	24	24	14	14	3	0.6

Table 5.1 Tightening of terminals

5.1.2 Electrical Installation and Control Cables

5

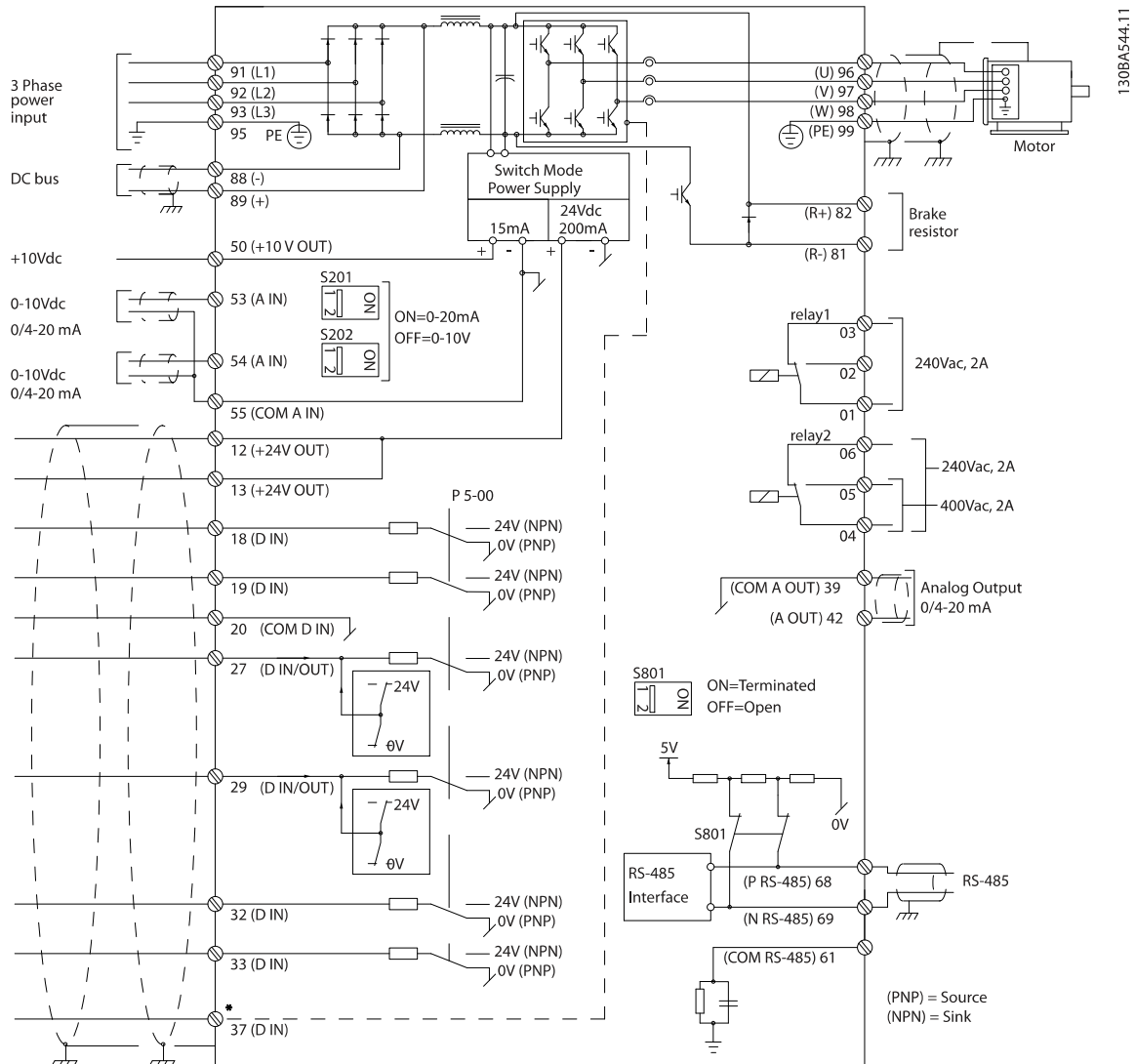

Illustration 5.1 Diagram showing all electrical terminals. (Terminal 37 present for units with Safe Stop Function only.)

Terminal number	Terminal description	Parameter number	Factory default
1+2+3	Terminal 1+2+3-Relay1	5-40	Alarm Running
4+5+6	Terminal 4+5+6-Relay2	5-40	Alarm Running
12	Terminal 12 Supply	-	+24 V DC
13	Terminal 13 Supply	-	+24 V DC
18	Terminal 18 Digital Input	5-10	Start
19	Terminal 19 Digital Input	5-11	Reversing
20	Terminal 20	-	Common
27	Terminal 27 Digital Input/Output	5-12/5-30	Coast inverse
29	Terminal 29 Digital Input/Output	5-13/5-31	Jog
32	Terminal 32 Digital Input	5-14	No operation
33	Terminal 33 Digital Input	5-15	No operation
37	Terminal 37 Digital Input	-	Safe Stop
42	Terminal 42 Analog Output	6-50	Speed 0-HighLim
53	Terminal 53 Analog Input	3-15/6-1*/20-0*	Reference
54	Terminal 54 Analog Input	3-15/6-2*/20-0*	Feedback

Table 5.2 Terminal connections

Very long control cables and analog signals may, in rare cases and depending on installation, result in 50/60 Hz earth loops due to noise from mains supply cables.

If this occurs, break the screen or insert a 100 nF capacitor between screen and chassis.

NOTE

The common of digital / analog inputs and outputs should be connected to separate common terminals 20, 39, and 55. This will avoid ground current interference among groups. For example, it avoids switching on digital inputs disturbing analog inputs.

NOTE

Control cables must be screened/armoured.

5.1.3 Fuses

Branch circuit protection

In order to protect the installation against electrical and fire hazard, all branch circuits in an installation, switch gear, machines etc., must be shortcircuit and overcurrent protected according to the national/international regulations.

Short circuit protection

The frequency converter must be protected against short-circuit to avoid electrical or fire hazard. Danfoss recommends using the fuses mentioned in tables 4.3 and 4.4 to protect service personnel or other equipment in case of an internal failure in the unit. The frequency converter provides full short circuit protection in case of a short-circuit on the motor output.

Over-current protection

Provide overload protection to avoid fire hazard due to overheating of the cables in the installation. Over current protection must always be carried out according to national regulations. The frequency converter is equipped with an internal over current protection that can be used for upstream overload protection (UL-applications excluded). See *ADAP-KOOL® Drive AKD102 Programming Guide, par. 4-18*. Fuses must be designed for protection in a circuit capable of supplying a maximum of 100,000 A_{rms} (symmetrical), 500 V/600 V maximum.

Non UL compliance

If UL/cUL is not to be complied with, Danfoss recommends using the fuses mentioned in table 4.2, which will ensure compliance with EN50178:

In case of malfunction, not following the recommendation may result in unnecessary damage to the frequency converter.

Frequency converter	Max. fuse size	Voltage	Type
200-240 V			
K25-K75	10A ¹	200-240 V	type gG
1K1-1K5	16A ¹	200-240 V	type gG
2K2	25A ¹	200-240 V	type gG
3K0	25A ¹	200-240 V	type gG
3K7	35A ¹	200-240 V	type gG
5K5	50A ¹	200-240 V	type gG
7K5	63A ¹	200-240 V	type gG
11K	63A ¹	200-240 V	type gG
15K	80A ¹	200-240 V	type gG
18K5	125A ¹	200-240 V	type gG
22K	125A ¹	200-240 V	type gG
30K	160A ¹	200-240 V	type gG
37K	200A ¹	200-240 V	type aR
45K	250A ¹	200-240 V	type aR
380-480 V			
K37-1K5	10A ¹	380-500 V	type gG
2K2-3K0	16A ¹	380-500 V	type gG
4K0-5K5	25A ¹	380-500 V	type gG
7K5	35A ¹	380-500 V	type gG
11K-15K	63A ¹	380-500 V	type gG
18K	63A ¹	380-500 V	type gG
22K	63A ¹	380-500 V	type gG
30K	80A ¹	380-500 V	type gG
37K	100A ¹	380-500 V	type gG
45K	125A ¹	380-500 V	type gG
55K	160A ¹	380-500 V	type gG
75K	250A ¹	380-500 V	type aR
90K	250A ¹	380-500 V	type aR

Table 5.3 Non UL fuses 200 V to 480 V

1) Max. fuses - see national/international regulations for selecting an applicable fuse size.

*170M fuses from Bussmann shown use the -/80 visual indicator, -TN/80 Type T, -/110 or TN/110 Type T indicator fuses of the same size and amperage may be substituted for external use.

Frequency converter	Bussmann	Bussmann	Bussmann	SIBA	Littel fuse	Ferraz-Shawmut	Ferraz-Shawmut
UL Compliance - 200-240 V							
kW	Type RK1	Type J	Type T	Type RK1	Type RK1	Type CC	Type RK1
K25-K37	KTN-R05	JKS-05	JJN-05	5017906-005	KLN-R005	ATM-R05	A2K-05R
K55-1K1	KTN-R10	JKS-10	JJN-10	5017906-010	KLN-R10	ATM-R10	A2K-10R
1K5	KTN-R15	JKS-15	JJN-15	5017906-015	KLN-R15	ATM-R15	A2K-15R
2K2	KTN-R20	JKS-20	JJN-20	5012406-020	KLN-R20	ATM-R20	A2K-20R
3K0	KTN-R25	JKS-25	JJN-25	5012406-025	KLN-R25	ATM-R25	A2K-25R
3K7	KTN-R30	JKS-30	JJN-30	5012406-030	KLN-R30	ATM-R30	A2K-30R
5K5	KTN-R50	JKS-50	JJN-50	5012406-050	KLN-R50	-	A2K-50R
7K5	KTN-R50	JKS-60	JJN-60	5012406-050	KLN-R60	-	A2K-50R
11K	KTN-R60	JKS-60	JJN-60	5014006-063	KLN-R60	A2K-60R	A2K-60R
15K	KTN-R80	JKS-80	JJN-80	5014006-080	KLN-R80	A2K-80R	A2K-80R
18K5	KTN-R125	JKS-150	JJN-125	2028220-125	KLN-R125	A2K-125R	A2K-125R
22K	KTN-R125	JKS-150	JJN-125	2028220-125	KLN-R125	A2K-125R	A2K-125R
30K	FWX-150	-	-	2028220-150	L255-150	A25X-150	A25X-150
37K	FWX-200	-	-	2028220-200	L255-200	A25X-200	A25X-200
45K	FWX-250	-	-	2028220-250	L255-250	A25X-250	A25X-250

Table 5.4 UL fuses 200 - 240 V

Frequency converter	Bussmann	Bussmann	Bussmann	SIBA	Littel fuse	Ferraz-Shawmut	Ferraz-Shawmut
UL Compliance - 380-480 V, 525-600							
kW	Type RK1	Type J	Type T	Type RK1	Type RK1	Type CC	Type RK1
K37-1K1	KTS-R6	JKS-6	JJS-6	5017906-006	KLS-R6	ATM-R6	A6K-6R
1K5-2K2	KTS-R10	JKS-10	JJS-10	5017906-010	KLS-R10	ATM-R10	A6K-10R
3K0	KTS-R15	JKS-15	JJS-15	5017906-016	KLS-R16	ATM-R16	A6K-16R
4K0	KTS-R20	JKS-20	JJS-20	5017906-020	KLS-R20	ATM-R20	A6K-20R
5K5	KTS-R25	JKS-25	JJS-25	5017906-025	KLS-R25	ATM-R25	A6K-25R
7K5	KTS-R30	JKS-30	JJS-30	5012406-032	KLS-R30	ATM-R30	A6K-30R
11K	KTS-R40	JKS-40	JJS-40	5014006-040	KLS-R40	-	A6K-40R
15K	KTS-R40	JKS-40	JJS-40	5014006-040	KLS-R40	-	A6K-40R
18K	KTS-R50	JKS-50	JJS-50	5014006-050	KLS-R50	-	A6K-50R
22K	KTS-R60	JKS-60	JJS-60	5014006-063	KLS-R60	-	A6K-60R
30K	KTS-R80	JKS-80	JJS-80	2028220-100	KLS-R80	-	A6K-80R
37K	KTS-R100	JKS-100	JJS-100	2028220-125	KLS-R100	-	A6K-100R
45K	KTS-R125	JKS-150	JJS-150	2028220-125	KLS-R125	-	A6K-125R
55K	KTS-R150	JKS-150	JJS-150	2028220-160	KLS-R150	-	A6K-150R
75K	FWH-220	-	-	2028220-200	L50S-225	-	A50-P225
90K	FWH-250	-	-	2028220-250	L50S-250	-	A50-P250

Table 5.5 UL fuses 380 - 600 V

KTS-fuses from Bussmann may substitute KTN for 240 V frequency converters.

FWH-fuses from Bussmann may substitute FWX for 240 V frequency converters.

KLSR fuses from LITTEL FUSE may substitute KLN-R fuses for 240 V frequency converters.

L50S fuses from LITTEL FUSE may substitute L50S fuses for 240 V frequency converters.

A6KR fuses from FERRAZ SHAWMUT may substitute A2KR for 240 V frequency converters.

A50X fuses from FERRAZ SHAWMUT may substitute A25X for 240 V frequency converters.

5.1.4 Earthing and IT mains

⚠ WARNING

The earth connection cable cross section must be at least 10 mm² or 2 rated mains wires terminated separately according to EN 50178 or IEC 61800-5-1 unless national regulations specify differently. Always comply with national and local regulations, on cable cross-sections.

The mains is connected to the main disconnect switch if this is included.

NOTE

Check that mains voltage corresponds to the mains voltage of the frequency converter name plate.

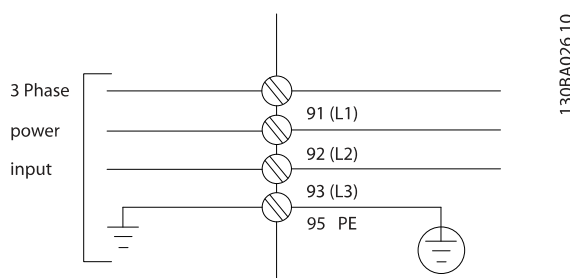

Illustration 5.2 Terminals for mains and earthing.

⚠ WARNING
IT Mains

Do not connect 400 V frequency converters with RFI-filters to mains supplies with a voltage between phase and earth of more than 440 V.

For IT mains and delta earth (grounded leg), mains voltage may exceed 440 V between phase and earth.

5.1.5 Mains Wiring Overview

Enclosure:	A2 (IP 20/IP 21)	A3 (IP 20/IP 21)	A5 (IP 55/IP 66)	B1 (IP 21/IP 55/IP 66)	B2 (IP 21/IP 55/IP 66)	C1 (IP 21/IP 55/66)	C2 (IP 21/IP 55/66)
							
Motor size:							
200-240 V	1.1-3.0 kW	3.7 kW	1.1-3.7 kW	5.5-11 kW	15 kW	18.5-30 kW	37-45 kW
380-480 V	1.1-4.0 kW	5.5-7.5 kW	1.1-7.5 kW	11-18.5 kW	22-30 kW	37-55 kW	75-90 kW
Goto:	5.1.6		5.1.7	5.1.8		5.1.9	

Table 5.6 Mains wiring table.

5.1.6 Mains Connection for A2 and A3

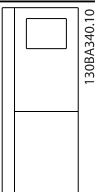
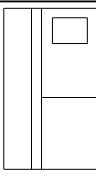
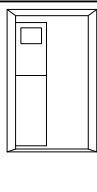
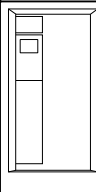
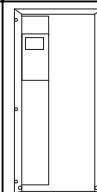
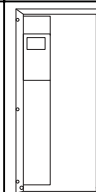
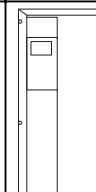
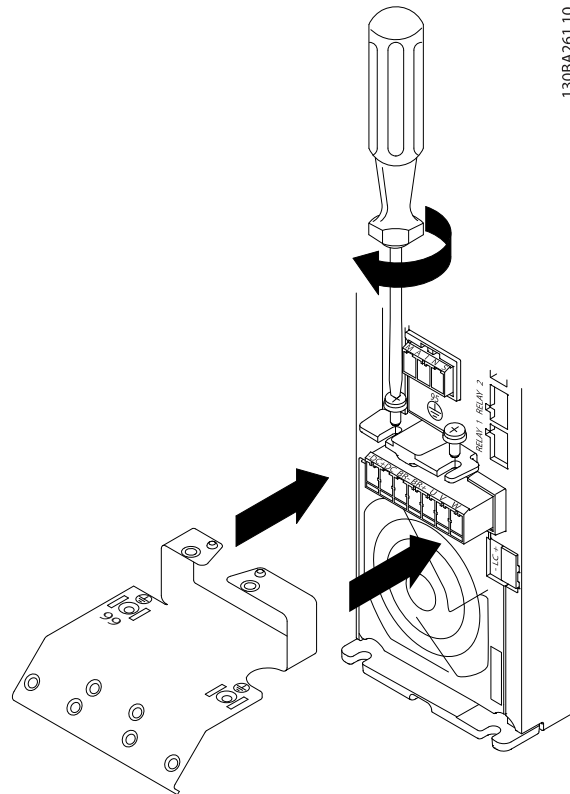

5

Illustration 5.3 First mount the two screws on the mounting plate, slide it into place and tighten fully.

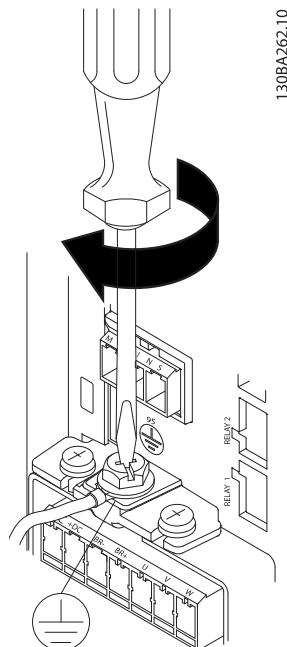

Illustration 5.4 When mounting cables, first mount and tighten earth cable.

⚠ WARNING

The earth connection cable cross section must be at least 10 mm² or 2 rated mains wires terminated separately according to EN 50178/IEC 61800-5-1.

5

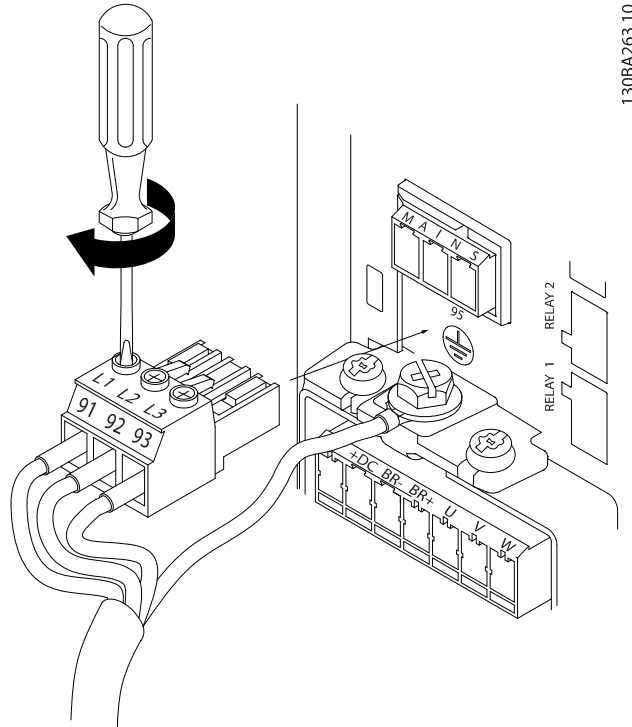

Illustration 5.5 Then mount mains plug and tighten wires.

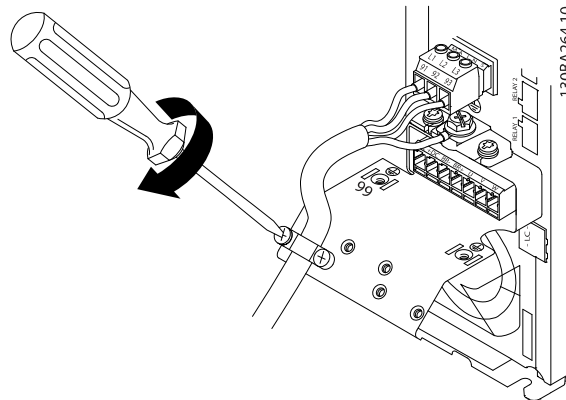

Illustration 5.6 Finally tighten support bracket on mains wires.

NOTE

With single phase A3 use L1 and L2 terminals.

5.1.7 Mains Connection for A5

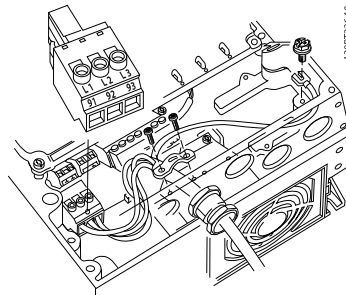

Illustration 5.7 How to connect to mains and earthing without mains disconnect switch. Note that a cable clamp is used.

5

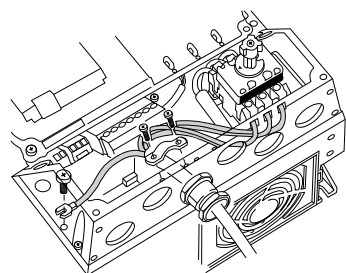

Illustration 5.8 How to connect to mains and earthing with mains disconnect switch.

NOTE

With single phase A5 use L1 and L2 terminals.

5.1.8 Mains Connection for B1 and B2

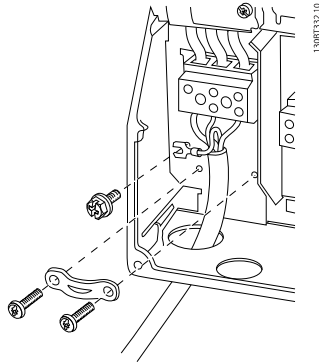

Illustration 5.9 How to connect to mains and earthing for B1 and B2.

NOTE

For correct cable dimensions please see the section General Specifications at the back of this manual.

5.1.9 Mains connection for C1 and C2

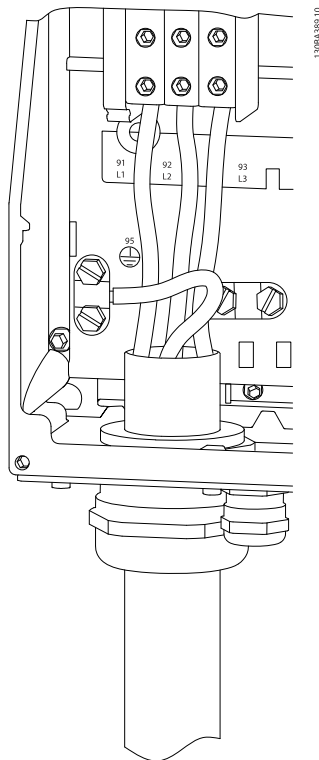

Illustration 5.10 How to connect to mains and earthing.

5.1.10 How to Connect Motor - Introduction

See section *General Specifications* for correct dimensioning of motor cable cross-section and length.

- Use a screened/armoured motor cable to comply with EMC emission specifications (or install the cable in metal conduit).
- Keep the motor cable as short as possible to reduce the noise level and leakage currents.
- Connect the motor cable screen/armour to both the decoupling plate of the frequency converter and to the metal of the motor. (Same applies to both ends of metal conduit if used instead of screen.)
- Make the screen connections with the largest possible surface area (cable clamp or by using an EMC cable gland). This is done by using the supplied installation devices in the frequency converter.
- Avoid terminating the screen by twisting the ends (pigtailed), as this will spoil high frequency screening effects.
- If it is necessary to break the continuity of the screen to install a motor isolator or motor relay, the continuity must be maintained with the lowest possible HF impedance.

5

Cable length and cross-section

The frequency converter has been tested with a given length of cable and a given cross-section of that cable. If the cross-section is increased, the cable capacitance - and thus the leakage current - may increase, and the cable length must be reduced correspondingly.

Switching frequency

When frequency converters are used together with sine wave filters to reduce the acoustic noise from a motor, the switching frequency must be set according to the sine wave filter instruction in *14-01 Switching Frequency*.

Precautions while using Aluminium conductors

Aluminium conductors are not recommended for cable cross sections below 35 mm². Terminals can accept aluminium conductors but the conductor surface has to be clean and the oxidation must be removed and sealed by neutral acid free Vaseline grease before the conductor is connected.

Furthermore, the terminal screw must be retightened after two days due to the softness of the aluminium. It is crucial to ensure the connection makes a gas tight joint, otherwise the aluminium surface will oxidize again.

All types of three-phase asynchronous standard motors can be connected to the frequency converter. Normally, small motors are star-connected (230/400 V, D/Y). Large motors are delta-connected (400/690 V, D/Y). Refer to the motor name plate for correct connection mode and voltage.

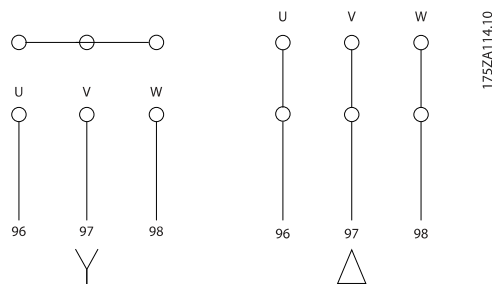

Illustration 5.11 Terminals for motor connection

NOTE

In motors without phase insulation paper or other insulation reinforcement suitable for operation with voltage supply (such as a frequency converter), fit a sine-wave filter on the output of the frequency converter. (Motors that comply with IEC 60034-17 do not require a Sine-wave filter).

No.	96	97	98	Motor voltage 0-100% of mains voltage.
	U	V	W	3 cables out of motor
	U1	V1	W1	6 cables out of motor, Delta-connected
	W2	U2	V2	
	U1	V1	W1	6 cables out of motor, Star-connected
				U2, V2, W2 to be interconnected separately (optional terminal block)
No.	99			Earth connection
	PE			

Table 5.7 3 and 6 cable motor connection.

5

5.1.11 Motor Wiring Overview

Enclosure:	A2 (IP 20/IP 21)	A3 (IP 20/IP 21)	A4 (IP 55/IP 66)	A5 (IP 55/IP 66)	B1 (IP 21/IP 55/ IP 66)	B2 (IP 21/IP 55/ IP 66)	C1 (IP 21/IP 55/66)	C2 (IP 21/IP 55/66)
								
Motor size:								
200-240 V	1.1-3.0 kW	3.7 kW	0.25-2.2 kW	1.1-3.7 kW	5.5-11 kW	15 kW	18.5-30 kW	37-45 kW
380-480 V	1.1-4.0 kW	5.5-7.5 kW	0.37-4.0 kW	1.1-7.5 kW	11-18.5 kW	22-30 kW	37-55 kW	75-90 kW
Goto:	5.1.12		5.1.13	5.1.13	5.1.14		5.1.15	

Table 5.8 Motor wiring table.

5.1.12 Motor Connection for A2 and A3

Follow these drawings step by step for connecting the motor to the frequency converter.

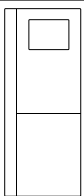
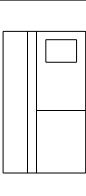
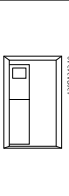
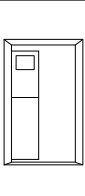
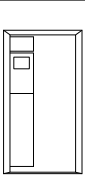
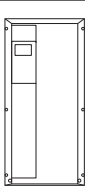
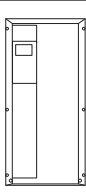
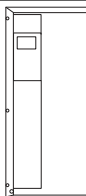
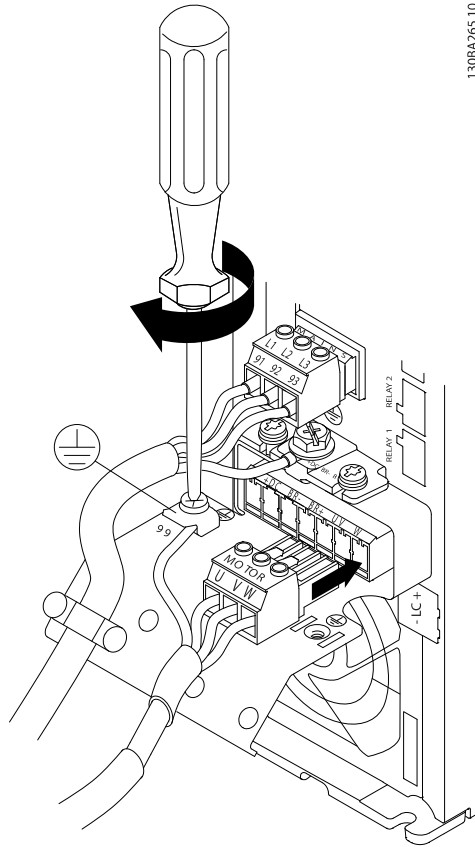

5

Illustration 5.12 First terminate the motor earth, then place motor U, V and W wires in plug and tighten.

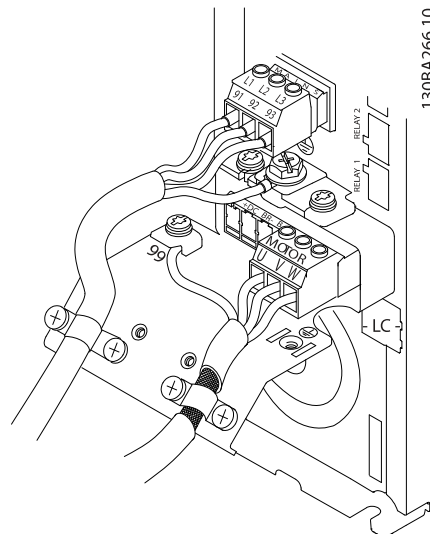
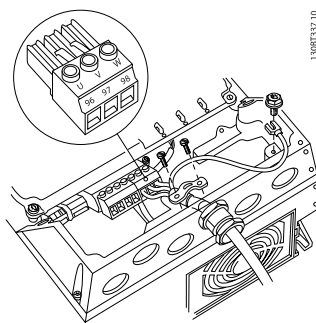

Illustration 5.13 Mount cable clamp to ensure 360 degree connection between chassis and screen, note the outer insulation of the motor cable is removed under the clamp.

5.1.13 Motor Connection for A4 and A5



5

Illustration 5.14 First terminate the motor earth, then place motor U, V and W wires in terminal and tighten. Please ensure that the outer insulation of the motor cable is removed under the EMC clamp.

5.1.14 Motor Connection for B1 and B2

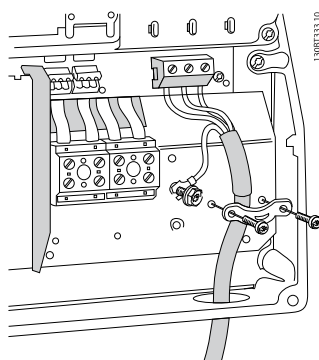

Illustration 5.15 First terminate the motor earth, then Place motor U, V and W wires in terminal and tighten. Please ensure that the outer insulation of the motor cable is removed under the EMC clamp.

5.1.15 Motor Connection for C1 and C2

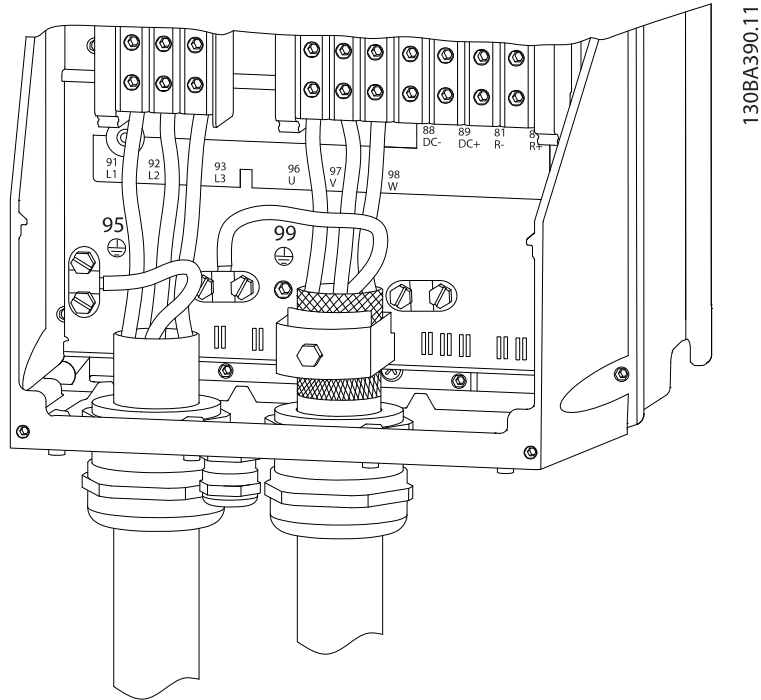

Illustration 5.16 First terminate the motor earth, then Place motor U, V and W wires in terminal and tighten. Please ensure that the outer insulation of the motor cable is removed under the EMC clamp.

5.1.16 Wiring Example and Testing

The following section describes how to terminate control wires and how to access them. For an explanation of the function, programming and wiring of the control terminals, please see chapter, *How to programme the frequency converter*.

5.1.17 Access to Control Terminals

All terminals to the control cables are located underneath the terminal cover on the front of the frequency converter. Remove the terminal cover with a screwdriver.

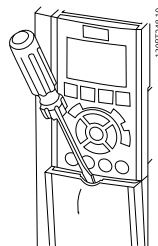

Illustration 5.17 Access to control terminals for A2, A3, B3, B4, C3 and C4 enclosures

Remove front-cover to access control terminals. When replacing the front-cover, please ensure proper fastening by applying a torque of 2 Nm.

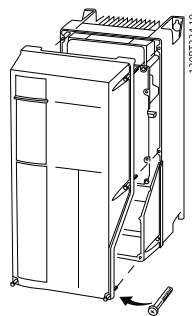

Illustration 5.18 Access to control terminals for A5, B1, B2, C1 and C2 enclosures

5

5.1.18 Control terminals

Drawing reference numbers:

1. 10-pole plug digital I/O.
2. 3-pole plug RS-485 Bus.
3. 6-pole analog I/O.
4. USB connection.

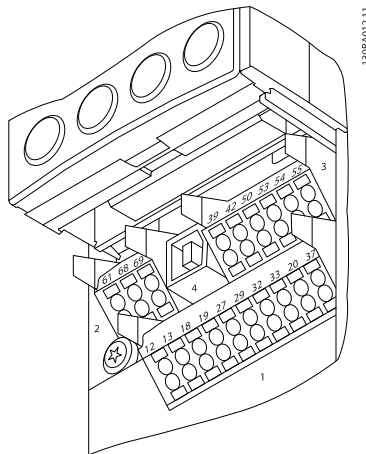

Illustration 5.19 Control terminals (all enclosures)

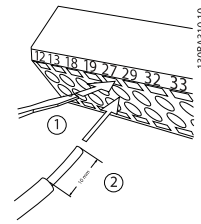

Illustration 5.21

Step 2: Insert one end in terminal 27 using a suitable terminal screwdriver. (Note: For units with Safe Stop function, the existing jumper between terminal 12 and 37 should not be removed for the unit to be able to run!)

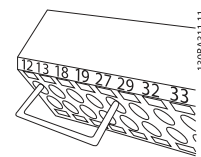

Illustration 5.22

Step 3: Insert the other end in terminal 12 or 13. (Note: For units with Safe Stop function, the existing jumper between terminal 12 and 37 should not be removed for the unit to be able to run!)

5.1.19 How to Test Motor and Direction of Rotation

⚠ WARNING

Unintended motor start can occur, ensure no personnel or equipment is in danger!

Please follow these steps to test the motor connection and direction of rotation. Start with no power to the unit.

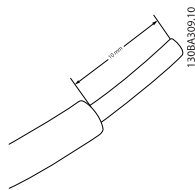

Illustration 5.20

Step 1: First remove the insulation on both ends of a 50 to 70 mm piece of wire.

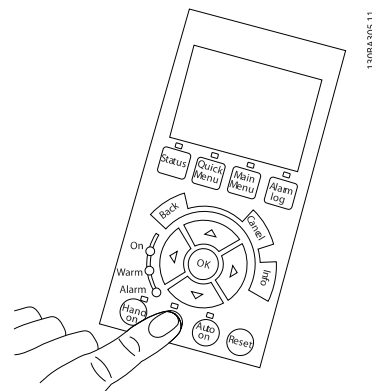

Illustration 5.23

Step 4: Power-up the unit and press the [Off] button. In this state the motor should not rotate. Press [Off] to stop the motor at any time. Note the LED at the [OFF] button should be lit. If alarms or warnings are flashing, please see chapter 7 regarding these.

5

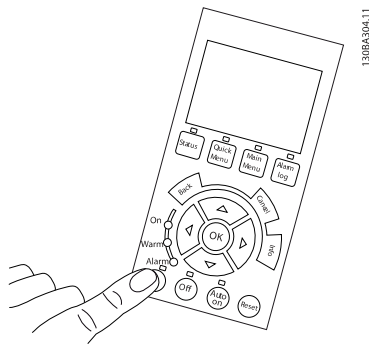

Illustration 5.24
Step 5: By pressing the [Hand on] button, the LED above the button should be lit and the motor may rotate.

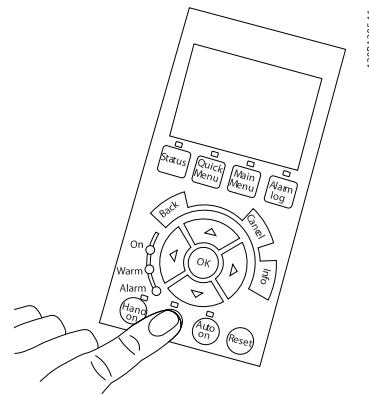

Illustration 5.27
Step 8: Press the [Off] button to stop the motor again.

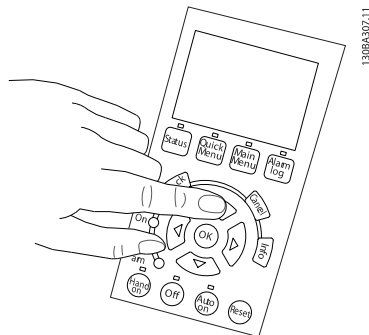

Illustration 5.25
Step 6: The speed of the motor can be seen in the LCP. It can be adjusted by pushing the up ▲ and down ▼ arrow buttons.

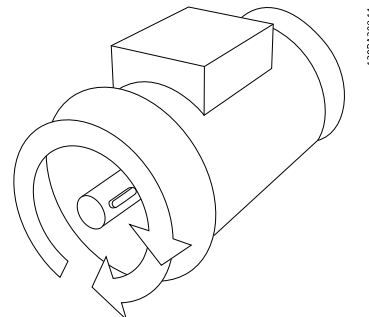

Illustration 5.28
Step 9: Change two motor wires if the desired rotation of direction is not achieved.

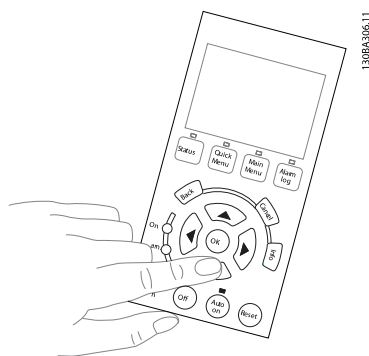

Illustration 5.26
Step 7: To move the cursor, use the left ◀ and right ▶ arrow buttons. This enables changing the speed in larger increments.

WARNING

Remove mains power from the frequency converter before changing motor wires.

5.1.20 Switches S201, S202, and S801

Switches S201 (AI 53) and S202 (AI 54) are used to select a current (0-20 mA) or a voltage (0 to 10 V) configuration of the analog input terminals 53 and 54 respectively.

Switch S801 (BUS TER.) can be used to enable termination on the RS-485 port (terminals 68 and 69).

Please note that the switches may be covered by an option, if fitted.

Default setting:

S201 (AI 53) = OFF (voltage input)

S202 (AI 54) = OFF (voltage input)

S801 (Bus termination) = OFF

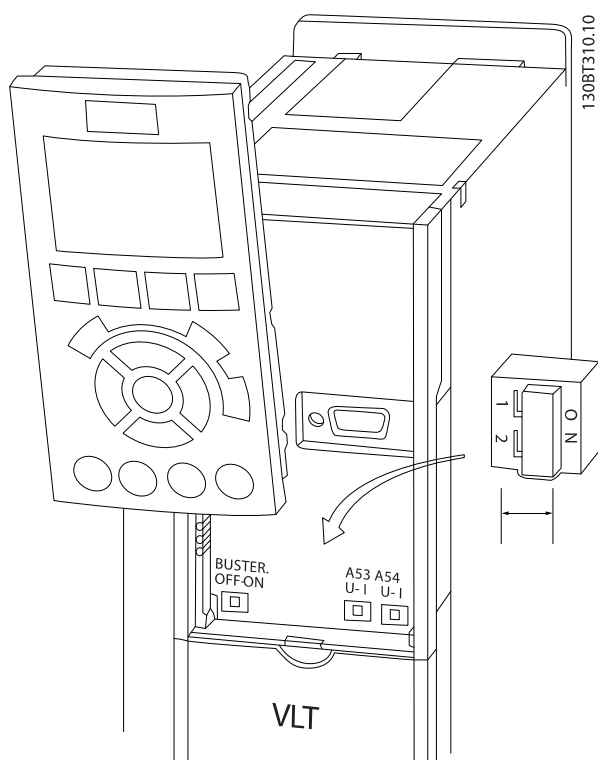

Illustration 5.29 Switches location.

5.2 Final Optimization and Test

To optimize motor shaft performance and optimize the frequency converter for the connected motor and installation, please follow these steps. Ensure that frequency converter and motor are connected and that power is applied to frequency converter.

NOTE

Before power up ensure that connected equipment is ready for use.

Step 1. Locate motor name plate

NOTE

The motor is either star- (Y) or delta- connected (Δ). This information is located on the motor name plate data.

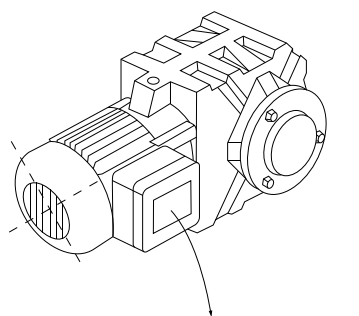

BAUER D-7 3734 ESILINGEN			
3- MOTOR NR. 1827421 2003			
S/E005A9			
	1,5	KW	
n ₂	31,5 /min.	400	Y V
n ₁	1400 /min.	50	Hz
COS φ	0,80	3,6	A
1,7L			
B	IP 65	H1/1A	

Illustration 5.30 Motor name plate example

Step 2. Enter motor name plate data in following parameter list

To access list first press [QUICK MENU] key then select "Q2 Quick Setup".

1.	Motor Power [kW] or Motor Power [HP]	par. 1-20 par. 1-21
2.	Motor Voltage	par. 1-22
3.	Motor Frequency	par. 1-23
4.	Motor Current	par. 1-24
5.	Motor Nominal Speed	par. 1-25

Table 5.9 Motor related parameters

Step 3. Activate Automatic Motor Adaptation (AMA)

Performing AMA ensures best possible performance. AMA automatically takes measurements from the specific motor connected and compensates for installation variances.

From the wizard you can run reduced AMA on compressors - in other cases please use the description below.

1. Connect terminal 27 to terminal 12 or use [QUICK MENU] and "Q2 Quick Setup" and set Terminal 27 par. 5-12 to *No function* (par. 5-12 [0])
2. Press [QUICK MENU], select "Q3 Function Setups", select "Q3-1 General Settings", select "Q3-10 Adv. Motor Settings" and scroll down to AMA par. 1-29.

3. Press [OK] to activate the AMA par. 1-29.
4. Choose between complete or reduced AMA. If sine wave filter is mounted, run only reduced AMA, or remove sine wave filter during AMA procedure.
5. Press [OK] key. Display should show "Press [Hand on] to start".
6. Press [Hand on] key. A progress bar indicates if AMA is in progress.

Stop the AMA during operation

1. Press the [OFF] key - the frequency converter enters into alarm mode and the display shows that the AMA was terminated by the user.

Successful AMA

1. The display shows "Press [OK] to finish AMA".
2. Press the [OK] key to exit the AMA state.

Unsuccessful AMA

1. The frequency converter enters into alarm mode. A description of the alarm can be found in the *Troubleshooting* section.
2. "Report Value" in the [Alarm Log] shows the last measuring sequence carried out by the AMA, before the frequency converter entered alarm mode. This number along with the description of the alarm will assist troubleshooting. If contacting Danfoss Service, make sure to mention number and alarm description.

NOTE

Unsuccessful AMA is often caused by incorrectly entered motor name plate data or too big difference between the motor power size and the frequency converter power size.

Step 4. Set speed limit and ramp time

Set up the desired limits for speed and ramp time.

Minimum Reference	par. 3-02
Maximum Reference	par. 3-03

Motor Speed Low Limit	par. 4-11 or 4-12
Motor Speed High Limit	par. 4-13 or 4-14

Ramp-up Time 1 [s]	par. 3-41
Ramp-down Time 1 [s]	par. 3-42

See the section *How to programme the frequency converter, Quick Menu Mode* for an easy set-up of these parameters.

6 How to Operate the Frequency Converter

6.1.1 Four Ways of Operating

The frequency converter can be operated in 4 ways:

1. Graphical Local Control Panel (GLCP)
2. RS-485 serial communication or USB, both for PC connection
3. Via AK Lon => Gateway => AKM programming software
4. Via Ak Lon => system manager => service tool programming software

If the frequency converter is fitted with fieldbus option, please refer to relevant documentation.

6.1.2 How to Operate the Graphical LCP (GLCP)

The following instructions are valid for the GLCP (LCP 102).

The GLCP is divided into four functional groups:

1. Graphical display with Status lines.
2. Menu keys and indicator lights (LED's) - selecting mode, changing parameters and switching between display functions.
3. Navigation keys and indicator lights (LEDs).
4. Operation keys and indicator lights (LEDs).

Graphical display:

The LCD-display is back-lit with a total of 6 alpha-numeric lines. All data is displayed on the LCP which can show up to five operating variables while in [Status] mode.

Display lines:

- a. **Status line:** Status messages displaying icons and graphics.
- b. **Line 1-2:** Operator data lines displaying data and variables defined or chosen by the user. By pressing the [Status] key, up to one extra line can be added.
- c. **Status line:** Status messages displaying text.

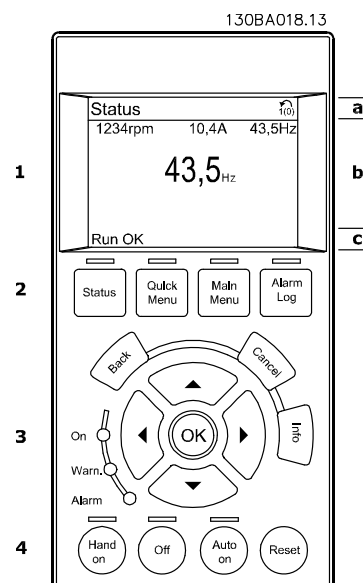

The display is divided into 3 sections:

Top section (a) shows the status when in status mode or up to 2 variables when not in status mode and in the case of Alarm/Warning.

The number of the Active Set-up (selected as the Active Set-up in par. 0-10) is shown. When programming in another Set-up than the Active Set-up, the number of the Set-up being programmed appears to the right in brackets.

The **Middle section** (b) shows up to 5 variables with related unit, regardless of status. In case of alarm/warning, the warning is shown instead of the variables.

It is possible to toggle between three status read-out displays by pressing the [Status] key. Operating variables with different formatting are shown in each status screen - see below.

6

Several values or measurements can be linked to each of the displayed operating variables. The values / measurements to be displayed can be defined via par. 0-20, 0-21, 0-22, 0-23, and 0-24, which can be accessed via [QUICK MENU], "Q3 Function Setups", "Q3-1 General Settings", "Q3-13 Display Settings".

Each value / measurement readout parameter selected in par. 0-20 to par. 0-24 has its own scale and number of digits after a possible decimal point. Larger numeric values are displayed with few digits after the decimal point.

Ex.: Current readout
5.25 A; 15.2 A 105 A.

Status display I:

This read-out state is standard after start-up or initialization.

Use [INFO] to obtain information about the value/ measurement linked to the displayed operating variables (1.1, 1.2, 1.3, 2, and 3).

See the operating variables shown in the display in this illustration. 1.1, 1.2 and 1.3 are shown in small size. 2 and 3 are shown in medium size.

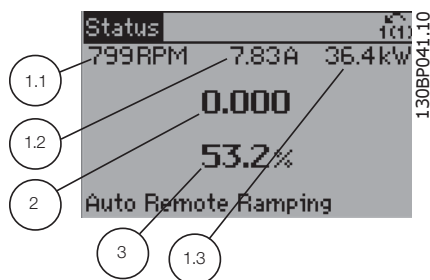

Status display II:

See the operating variables (1.1, 1.2, 1.3, and 2) shown in the display in this illustration.

In the example, Speed, Motor current, Motor power and Frequency are selected as variables in the first and second lines.

1.1, 1.2 and 1.3 are shown in small size. 2 is shown in large size.

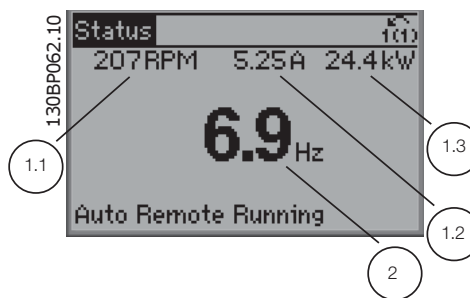

Status display III:

This state displays the event and action of the Smart Logic Control. For further information, see section *Smart Logic Control*.



130BP045.10

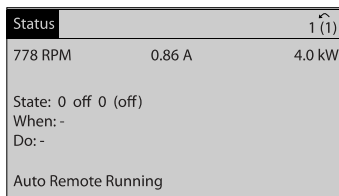

130BP063.10

The **Bottom section** always shows the state of the frequency converter in Status mode.

Display Contrast Adjustment

Press [status] and [▲] for darker display

Press [status] and [▼] for brighter display

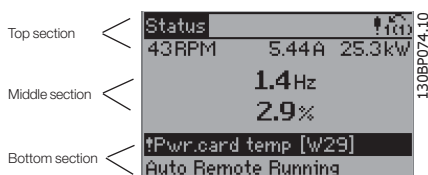

130BP074.10

Indicator lights (LEDs):

If certain threshold values are exceeded, the alarm and/or warning LED lights up. A status and alarm text appear on the control panel.

The On LED is activated when the frequency converter receives power from mains voltage, a DC bus terminal, or an external 24 V supply. At the same time, the back light is on.

- Green LED/On: Control section is working.
- Yellow LED/Warn.: Indicates a warning.
- Flashing Red LED/Alarm: Indicates an alarm.

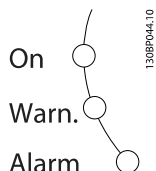

130BP044.10

GLCP keys

Menu keys

The menu keys are divided into functions. The keys below the display and indicator lamps are used for parameter set-up, including choice of display indication during normal operation.

[Status]

indicates the status of the frequency converter and/or the motor. 3 different readouts can be chosen by pressing the [Status] key:

5 line readouts, 4 line readouts or Smart Logic Control.

Use [Status] for selecting the mode of display or for changing back to Display mode from either the Quick Menu mode, the Main Menu mode or Alarm mode. Also use the [Status] key to toggle single or double read-out mode.

[Quick Menu]

allows quick set-up of the frequency converter. **The most common ADAP-KOOL® functions can be programmed here.**

The [Quick Menu] consists of:

- My Personal Menu
- Quick Set-up
- Function set-up
- AKD102 Wizard Menu
- Changes Made
- Loggings

The Function set-up provides quick and easy access to all parameters required for the majority of ADAP-KOOL® applications including most VAV and CAV supply and return fans, cooling tower fans, Primary, Secondary and Condenser Water Pumps and other pump, fan and compressor applications. Amongst other features it also includes parameters for selecting which variables to display on the LCP, digital preset speeds, scaling of analog references, closed loop single zone and multi-zone applications and specific functions related to Fans, Pumps and Compressors.

The Quick Menu parameters can be accessed immediately unless a password has been created via par. 0-60, 0-61, 0-65 or 0-66.

It is possible to switch directly between Quick Menu mode and Main Menu mode.

6

[Main Menu]

is used for programming all parameters. The Main Menu parameters can be accessed immediately unless a password has been created via par. 0-60, 0-61, 0-65 or 0-66. For the majority of ADAP-KOOL® applications it is not necessary to access the Main Menu parameters but instead the Quick Menu, Quick Set-up and Function Set-up provides the simplest and quickest access to the typical required parameters.

It is possible to switch directly between Main Menu mode and Quick Menu mode.

Parameter shortcut can be carried out by pressing down the **[Main Menu]** key for 3 seconds. The parameter shortcut allows direct access to any parameter.

[Alarm Log]

displays an Alarm list of the five latest alarms (numbered A1-A5). To obtain additional details about an alarm, use the arrow keys to manoeuvre to the alarm number and press **[OK]**. Information is displayed about the condition of the frequency converter before it enters the alarm mode.

The Alarm log button on the LCP allows access to both Alarm log and Maintenance log.

[Back]

reverts to the previous step or layer in the navigation structure.

[Cancel]

last change or command will be cancelled as long as the display has not been changed.

[Info]

displays information about a command, parameter, or function in any display window. **[Info]** provides detailed information when needed.

Exit Info mode by pressing either **[Info]**, **[Back]**, or **[Cancel]**.



Navigation Keys

The four navigation arrows are used to navigate between the different choices available in **[Quick Menu]**, **[Main Menu]** and **[Alarm Log]**. Use the keys to move the cursor.

[OK] is used for choosing a parameter marked by the cursor and for enabling the change of a parameter.



130BT117.10

Operation Keys for local control are found at the bottom of the control panel.

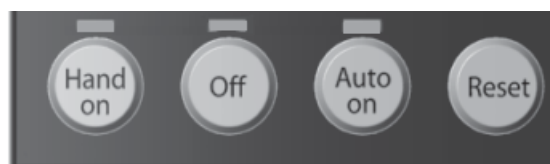

130BP046.10

[Hand On]

enables control of the frequency converter via the GLCP. [Hand on] also starts the motor, and it is now possible to enter the motor speed data by means of the arrow keys. The key can be selected as *Enable* [1] or *Disable* [0] via par. 0-40 [Hand on] key on LCP.

The following control signals will still be active when [Hand on] is activated:

- [Hand on] - [Off] - [Auto on]
- Reset
- Coasting stop inverse
- Reversing
- Set-up select lsb - Set-up select msb
- Stop command from serial communication
- Quick stop
- DC brake

NOTE

External stop signals activated by means of control signals or a serial bus will override a “start” command via the LCP.

[Off]

stops the connected motor. The key can be selected as *Enable* [1] or *Disable* [0] via par. 0-41 [Off] key on LCP. If no external stop function is selected and the [Off] key is inactive the motor can only be stopped by disconnecting the mains supply.

[Auto On]

enables the frequency converter to be controlled via the control terminals and/or serial communication. When a start signal is applied on the control terminals and/or the bus, the frequency converter will start. The key can be selected as *Enable* [1] or *Disable* [0] via par. 0-42 [Auto on] key on LCP.

NOTE

An active HAND-OFF-AUTO signal via the digital inputs has higher priority than the control keys [Hand on] – [Auto on].

[Reset]

is used for resetting the frequency converter after an alarm (trip). It can be selected as *Enable* [1] or *Disable* [0] via par. 0-43 *Reset Keys* on LCP.

The parameter shortcut can be carried out by holding down the [Main Menu] key for 3 seconds. The parameter shortcut allows direct access to any parameter.

6.1.3 RS-485 Bus Connection

One or more frequency converters can be connected to a controller (or master) using the RS-485 standard interface. Terminal 68 is connected to the P signal (TX+, RX+), while terminal 69 is connected to the N signal (TX-,RX-).

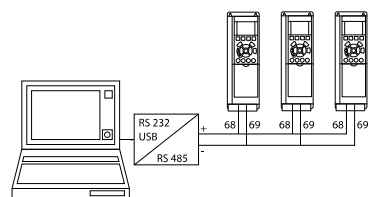

Illustration 6.1 Connection example.

If more than one frequency converter is connected to a master, use parallel connections.

In order to avoid potential equalizing currents in the screen, earth the cable screen via terminal 61, which is connected to the frame via an RC-link.

Bus termination

The RS-485 bus must be terminated by a resistor network at both ends. If the drive is the first or the last device in the RS-485 loop, set the switch S801 on the control card for ON.

For more information, see the paragraph *Switches S201, S202, and S801*.

6.1.4 How to Connect a PC to the AKD 102

To control or program the frequency converter from a PC, install the MCT 10 Set-up Software.

The PC is connected via a standard (host/device) USB cable, or via the RS-485 interface as shown in the *ADAP-KOOL® Drive AKD102 Design Guide, chapter How to Install > Installation of misc. connections*.

NOTE

The USB connection is galvanically isolated from the supply voltage (PELV) and other high-voltage terminals. The USB connection is connected to protection earth on the frequency converter. Use only isolated laptop as PC connection to the USB connector on the ADAP-KOOL® Drive.

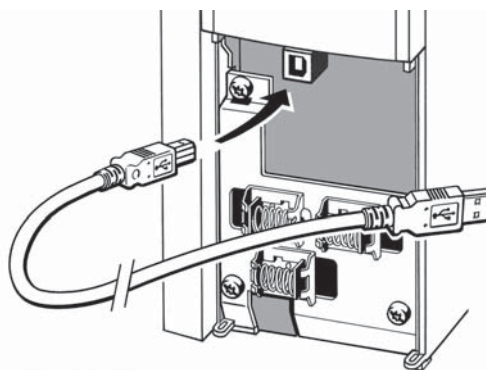

130BT308.11

6.1.5 PC Software Tools

PC-based Configuration Tool MCT 10

All Frequency converters are equipped with a serial communication port. Danfoss provides a PC tool for communication between PC and frequency converter, PC-based Configuration Tool MCT 10. Please check the section on *Available Literature* for detailed information on this tool.

MCT 10 Set-up Software

MCT 10 has been designed as an easy to use interactive tool for setting parameters in our frequency converters. . The xMCT 10 Set-up software will be useful for:

- Planning a communication network off-line. MCT 10 contains a complete frequency converter database
- Commissioning frequency converters on line
- Saving settings for all frequency converters
- Replacing a frequency converter in a network
- Simple and accurate documentation of frequency converter settings after commissioning.
- Expanding an existing network
- Future developed frequency converters will be supported

Save Frequency Converter Settings:

1. Connect a PC to the unit via USB com port. (Note: Use a PC, which is isolated from the mains, in conjunction with the USB port. Failure to do so may damage equipment.)
2. Open MCT 10 Set-up Software
3. Choose "Read from drive"
4. Choose "Save as"

All parameters are now stored in the PC.

Load Frequency Converter Settings:

1. Connect a PC to the frequency converter via USB com port
2. Open MCT 10 Set-up software
3. Choose "Open"– stored files will be shown
4. Open the appropriate file
5. Choose "Write to drive"

All parameter settings are now transferred to the frequency converter.

A separate manual for MCT 10 Set-up Software is available: *MG.10.Rx.yy*.

The MCT 10 Set-up Software Modules

The following modules are included in the software package:

	<p>MCT Set-up 10 Software Setting parameters Copy to and from frequency converters Documentation and print out of parameter settings incl. diagrams</p>
	<p>Ext. User Interface Preventive Maintenance Schedule Clock settings Timed Action Programming Smart Logic Controller Set-up</p>

Ordering number:

Please order the CD containing MCT 10 Set-up Software using code number 130B1000.

6.1.6 Tips and Tricks

*	For the majority of ADAP-KOOL applications the Quick Menu, Quick Set-up and Function Set-up provides the simplest and quickest access to all the typical parameters required.
*	Whenever possible, performing an AMA, will ensure best shaft performance
*	Contrast of the display can be adjusted by pressing [Status] and [▲] for darker display or by pressing [Status] and [▼] for brighter display
*	Under [Quick Menu] and [Changes Made] all parameters that have been changed from factory settings are displayed
*	Press and hold [Main Menu] key for 3 seconds for access to any parameter
*	For service purposes it is recommended to copy all parameters to the LCP, see par 0-50 for further information

Table 6.1 Tips and tricks

6.1.7 Quick Transfer of Parameter Settings when Using GLCP

Once the set-up of a frequency converter is complete, it is recommended to store (backup) the parameter settings in the GLCP or on a PC via MCT 10 Set-up Software Tool.

⚠ WARNING

Stop the motor before performing any of these operations.

Data storage in LCP:

1. Go to 0-50 LCP Copy
2. Press the [OK] key
3. Select "All to LCP"
4. Press the [OK] key

All parameter settings are now stored in the GLCP indicated by the progress bar. When 100% is reached, press [OK].

The GLCP can now be connected to another frequency converter and the parameter settings copied to this frequency converter.

Data transfer from LCP to Frequency converter:

1. Go to 0-50 LCP Copy
2. Press the [OK] key
3. Select "All from LCP"
4. Press the [OK] key

The parameter settings stored in the GLCP are now transferred to the frequency converter indicated by the progress bar. When 100% is reached, press [OK].

6.1.8 Initialisation to Default Settings

There are two ways to initialise the frequency converter to default: Recommended initialisation and manual initialisation. Please be aware that they have different impact according to the below description.

Recommended initialisation (via 14-22 Operation Mode)

1. Select 14-22 Operation Mode
2. Press [OK]
3. Select "Initialisation" (for NLCP select "2")
4. Press [OK]

5. Remove power to unit and wait for display to turn off.
6. Reconnect power and the frequency converter is reset. Note that first start-up takes a few more seconds
7. Press [Reset]

14-22 Operation Mode initialises all except:
14-50 RFI Filter
8-30 Protocol
8-31 Address
8-32 Baud Rate
8-35 Minimum Response Delay
8-36 Max Response Delay
8-37 Maximum Inter-Char Delay
15-00 Operating Hours to 15-05 Over Volt's
15-20 Historic Log: Event to 15-22 Historic Log: Time
15-30 Alarm Log: Error Code to 15-32 Alarm Log: Time

NOTE

Parameters selected in *0-25 My Personal Menu*, will stay present, with default factory setting.

Manual initialisation

NOTE

When carrying out manual initialisation, serial communication, RFI filter settings and fault log settings are reset. Removes parameters selected in *0-25 My Personal Menu*.

1. Disconnect from mains and wait until the display turns off.
- 2a. Press [Status] - [Main Menu] - [OK] at the same time while power up for Graphical LCP (GLCP)
- 2b. Press [Menu] while power up for LCP 101, Numerical Display
3. Release the keys after 5 s
4. The frequency converter is now programmed according to default settings

This parameter initialises all except:
15-00 Operating Hours
15-03 Power Up's
15-04 Over Temp's
15-05 Over Volt's

7 How to Programme the Frequency Converter

7.1 How to Programme

7.1.1 Parameter Set-Up

Group	Title	Function
0-	Operation and Display	Parameters used to program the fundamental functions of the frequency converter and the LCP including: selection of language; selection of which variables are displayed at each position in the display (e.g. static duct pressure or condenser water return temperature can be displayed with the setpoint in small digits in the top row and feedback in large digits in the centre of the display); enabling/disabling of the LCP keys/buttons; passwords for the LCP; upload and download of commissioned parameters to/from the LCP and setting the built in clock.
1-	Load / Motor	Parameters used to configure the frequency converter for the specific application and motor including: open or closed loop operation; type of application such as compressor, fan or centrifugal pump; motor nameplate data; auto-tuning of the drive to the motor for optimum performance; flying start (typically used for fan applications) and motor thermal protection.
2-	Brakes	Parameters used to configure braking functions of the frequency converter which although not common in many ADAP-KOOL applications, can be useful on special fan applications. Parameters including: DC braking and resistor braking.
3-	Reference / Ramps	Parameters used to program the minimum and maximum reference limits of speed (RPM/Hz) in open loop or in actual units when operating in closed loop; digital/preset references; jog speed; definition of the source of each reference (e.g. which analog input the reference signal is connected to); ramp up and down times and digital potentiometer settings.
4-	Limits / Warnings	Parameters used to program limits and warnings of operation including: allowable motor direction; minimum and maximum motor speeds ; torque and current limits to protect the pump, fan or compressor driven by the motor; warnings for low/high current, speed, reference, and feedback; missing motor phase protection; speed bypass frequencies including semi-automatic setup of these frequencies (e.g. to avoid resonance conditions on cooling tower and other fans).
5-	Digital In / Out	Parameters used to program the functions of all digital inputs, digital outputs, relay outputs, pulse inputs and pulse outputs for terminals on the control card and all option cards.
6-	Analog In / Out	Parameters used to program the functions associated with all analog inputs and analog outputs for the terminals on the control card and General Purpose I/O option (MCB108) (note: NOT Analog I/O option MCB109, see parameter group 26-**) including: analog input live zero timeout function (which for example can be used to command a cooling tower fan to operate at full speed if the condenser water return sensor fails); scaling of the analog input signals (for example to match the analog input to the mA and pressure range of a static duct pressure sensor); filter time constant to filter out electrical noise on the analog signal which can sometimes occur when long cables are installed; function and scaling of the analog outputs (for example to provide an analog output representing motor current or kW to an analog input of a DDC controller) and to configure the analog outputs to be controlled by the BMS via a high level interface (HLI) (e.g. to control a chilled water valve) including ability to define a default value of these outputs in the event of the HLI failing.
8-	Communication and Options	Parameters used for configuring and monitoring functions associated with the serial communications / high level interface to the frequency converter
14-	Special Functions	Parameters used to configure special functions of the frequency converter including: setting of the switching frequency to reduce audible noise from the motor (sometimes required for fan applications); kinetic back-up function (especially useful for critical applications in semi-conductor installations where performance under mains dip/mains loss is important); mains imbalance protection; automatic reset (to avoid the need for a manual reset of Alarms); energy optimisation parameters (which typically do not need changing but enable fine tuning of this automatic function (if necessary) ensuring the frequency converter and motor combination operate at their optimum efficiency at full and partial load conditions) and auto-derating functions (which enable the frequency converter to continue operation at reduced performance under extreme operating conditions ensuring maximum up time).
15-	FC Information	Parameters providing operating data and other drive information including: operating and running hour counters; kWh counter; resetting of the running and kWh counters; alarm/fault log (where the past 10 alarms are logged along with any associated value and time) and drive and option card identification parameters such as code number and software version.
16-	Data Readouts	Read only parameters which display the status/value of many operating variables which can be displayed on the LCP or viewed in this parameter group. These parameters can be particularly useful during commissioning when interfacing with a BMS via a high level interface.
18-	Info & Readouts	Read only parameters which display the last 10 preventative maintenance log items, actions and time and the value of analog inputs and outputs on the Analog I/O option card which can be particularly useful during commissioning when interfacing with a BMS via a high level interface.
20-	FC Closed Loop	Parameters used to configure the closed loop PI(D) controller which controls the speed of the pump, fan or compressor in closed loop mode including: defining where each of the 3 possible feedback signals come from (e.g. which analog input or the BMS HLI); conversion factor for each of the feedback signals (e.g. where a pressure signal is used for indication of flow in an AHU or converting from pressure to temperature in a compressor application); engineering unit for the reference and feedback (e.g. Pa, kPa, m Wg, in Wg, bar, m3/s, m3/h, °C, °F etc); the function (e.g. sum, difference, average, minimum or maximum) used to calculate the resulting feedback for single zone applications or the control philosophy for multi-zone applications; programming of the setpoint(s) and manual or auto-tuning of the PI(D) loop.

Table 7.1 Parameter Groups

Group	Title	Function
21-	Extended Closed Loop	Parameters used to configure the 3 extended closed loop PI(D) controllers which for example can be used to control external actuators (e.g. chilled water valve to maintain supply air temperature in a VAV system) including: engineering unit for the reference and feedback of each controller (e.g. °C, °F etc); defining the range of the reference/setpoint for each controller; defining where each of the references/setpoints and feedback signals come from (e.g. which analog input or the BMS HLI); programming of the setpoint and manual or auto-tuning of each of the PI(D) controllers.
22-	Application Functions	Parameters used to monitor, protect and control pumps, fans and compressors including: no flow detection and protection of pumps (including auto-setup of this function); dry pump protection; end of curve detection and protection of pumps; sleep mode (especially useful for cooling tower and booster pump sets); broken belt detection (typically used for fan applications to detect no air flow instead of using a Δp switch installed across the fan); short cycle protection of compressors and pump flow compensation of setpoint (especially useful for secondary chilled water pump applications where the Δp sensor has been installed close to the pump and not across the furthest most significant load(s) in the system; using this function can compensate for the sensor installation and help to realise the maximum energy savings).
23-	Time Based Functions	Time based parameters including: those used to initiate daily or weekly actions based on the built in real time clock (e.g. change of setpoint for night set back mode or start/stop of the pump/fan/compressor start/stop of an external equipment); preventative maintenance functions which can be based on running or operating hour time intervals or on specific dates and times; energy log (especially useful in retrofit applications or where information of the actual historical load (kW) on the pump/fan/compressor is of interest); trending (especially useful in retrofit or other applications where there is an interest to log operating power, current, frequency or speed of the pump/fan/compressor for analysis and a payback counter).
24-	Application Functions 2	Parameters used to set-up Fire Mode and/or to control a bypass contactor/starter if designed into the system.
25-	Pack Controller	Parameters used to configure and monitor the built in compressor pack controller (typically used for pump booster sets).
26-	Analog I/O Option MCB 109	Parameters used to configure the Analog I/O option (MCB109) including: definition of the analog input types (e.g. voltage, Pt1000 or Ni1000) and scaling and definition of the analog output functions and scaling.
28-	Compressor Functions	Parameters related to compressor functions: <ul style="list-style-type: none"> - Discharge temperature limits/ monitoring - Day/ Night settings - PO Optimization - Injection control

Parameter descriptions and selections are displayed on the graphic (GLCP) or numeric (NLCP) display. (See relevant section for details.) Access the parameters by pressing the [Quick Menu] or [Main Menu] button on the control panel. The Quick Menu is used primarily for commissioning the unit at start-up by providing the parameters necessary to start operation. The Main Menu provides access to all parameters for detailed application programming.

All digital input/output and analog input/output terminals are multifunctional. All terminals have factory default functions suitable for the majority of ADAP-KOOL applications but if other special functions are required, they must be programmed as explained in parameter group 5 or 6.

7.1.2 Quick Menu Mode

Parameter Data

The graphical display (GLCP) provides access to all parameters listed under the Quick Menus. To set parameters using the [Quick Menu] button - enter or change parameter data or settings in accordance with the following procedure:

1. Press Quick Menu button
2. Use the [▲] and [▼] buttons to find the parameter you want to change
3. Press [OK]
4. Use [▲] and [▼] buttons to select the correct parameter setting
5. Press [OK]
6. To move to a different digit within a parameter setting, use the [◀] and [▶] buttons
7. Highlighted area indicates digit selected for change
8. Press [Cancel] button to disregard change, or press [OK] to accept change and enter the new setting

Example of Changing Parameter Data

Assume parameter 22-60, *Broken Belt Function* is set to [Off]. However, you want to monitor the fan-belt condition - non-broken or broken - according to the following procedure:

1. Press Quick Menu key
2. Choose Function Setups with the [▼] button
3. Press [OK]
4. Choose Application Settings with the [▼] button
5. Press [OK]
6. Press [OK] again for Fan Functions
7. Choose Broken Belt Function by pressing [OK]
8. With [▼] button, choose [2] Trip

The frequency converter will now trip if a broken fan-belt is detected.

Select [My Personal Menu] to display only the parameters, which have been pre-selected and programmed as personal parameters. For example, an AHU or pump OEM may have pre-programmed these to be in My Personal Menu during factory commissioning to make on-site commissioning / fine tuning simpler. These parameters are selected in par. 0-25 *Personal Menu*. Up to 20 different parameters can be programmed in this menu.

If [No Operation] is selected in par. 5-12 *Terminal 27 Digital Input*, no connection to +24 V on terminal 27 is necessary to enable start.

If [Coast Inverse] (factory default value) is selected in par. 5-12 *Terminal 27 Digital Input*, a connection to +24V is necessary to enable start.

Select [Changes Made] to get information about:

- the last 10 changes. Use the up/down navigation keys to scroll between the last 10 changed parameters.
- the changes made since factory setting.

Select [Loggings] to get information about the display line read-outs. The information is shown as graphs.

Only display parameters selected in par. 0-20 and par. 0-24 can be viewed. It is possible to store up to 120 samples in the memory for later reference.

Efficient Parameter Set-up for ADAP-KOOL Applications

The parameters can easily be set up for the vast majority of the ADAP-KOOL applications only by using the [Quick Setup] option. After pressing [Quick Menu], the different choices in the Quick Menu are listed. See also illustration 6.1 below and tables Q3-1 to Q3-4 in the following *Function Setups* section.

Example of using the Quick Setup option

Assume you want to set the Ramp Down Time to 100 seconds

1. Select [Quick Setup]. The first par. 0-01 *Language* in Quick Setup appears
2. Press [▼] repeatedly until par. 3-42 *Ramp 1 Ramp Down Time* appears with the default setting of 20 seconds
3. Press [OK]
4. Use the [◀] button to highlight the 3rd digit before the comma
5. Change '0' to '1' by using the [▲] button
6. Use the [▶] button to highlight the digit '2'
7. Change '2' to '0' with the [▼] button
8. Press [OK]

The new ramp-down time is now set to 100 seconds. It is recommended to do the set-up in the order listed.

Par.	Designation	[Units]
0-01	Language	
1-03	Torque characteristics	
1-20	Motor Power	[kW]
1-21	Motor Power*	[HP]
1-22	Motor Voltage	[V]
1-23	Motor Frequency	[Hz]
1-24	Motor Current	[A]
1-25	Motor Nominal Speed	[RPM]
1-39	Motor Poles	
4-12	Motor Speed Low Limit*	[Hz]
4-14	Motor Speed High Limit*	[Hz]
3-02	Minimum Reference	
3-03	Maximum Reference	
3-41	Ramp 1 Ramp up Time	[s]
3-42	Ramp 1 Ramp down Time	[s]
3-13	Reference Site	
5-10	Terminal 18 Digital Input	
1-29	Automatic Motor Adaptation (AMA)	

Table 7.2 Quick Setup parameters

NOTE

A complete description of the function is found in the parameter sections of these Operating Instructions.

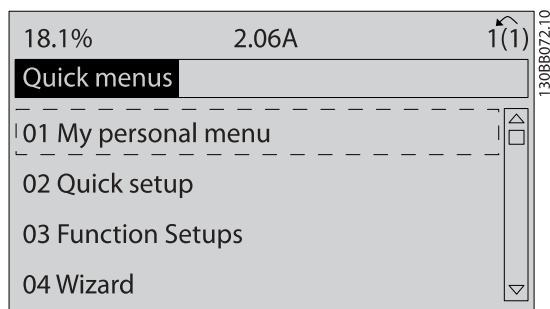

Illustration 7.1 Quick Menu view.

The Quick Setup menu gives access to the 13 most important setup parameters of the drive. After programming the drive will, in most cases be ready for operation. The 13* Quick Setup parameters are shown in the table below. A complete description of the function is given in the parameter description sections of this manual. The display showing depends on choices made in parameter 0-02 and 0-03. The default setting of parameters 0-02 and 0-03 depends on which region of the world the frequency converter is supplied to but can be re-programmed as required.

0-01 Language

Option:	Function:
	Defines the language to be used in the display. The frequency converter can be delivered with 4 different language packages. English and German are included in all packages. English cannot be erased or manipulated.
[0] *	English Part of Language packages 1 - 4
[1]	German Part of Language packages 1 - 4
[2]	French Part of Language package 1
[4]	Spanish Part of Language package 1
[5]	Italian Part of Language package 1
[7]	Dutch Part of Language package 1

1-03 Torque Characteristics

Option:	Function:
[0] * Compressor CT	For speed control of screw and scroll compressors. Provides a voltage which is optimized for a constant torque load characteristic of the motor in the entire range down to 15 Hz.
[1] Condenser VT	For speed control of centrifugal pumps and fans. Also to be used when controlling more than one motor from the same frequency converter (e.g. multiple condenser fans or cooling tower fans). Provides a voltage which is optimized for a squared torque load characteristic of the motor.
[2] Compressor AEO CT	<i>Auto Energy Optimization Compressor</i> . For optimum energy efficient speed control of screw, scroll and piston compressors. Provides a voltage which is optimized for a constant torque load characteristic of the motor in the entire range down to 15Hz but in addition the AEO feature will adapt the voltage exactly to the current load situation, thereby reducing energy consumption and audible noise from the motor. To obtain optimal performance, the motor power factor cos phi must be set correctly. This value is set in par. 14-43, Motor cos phi. The parameter has a default value which is automatically adjusted when the motor data is programmed. These settings will typically ensure optimum motor voltage but if the motor power factor cos phi requires tuning, an AMA function can be carried out using par. 1-29, Automatic Motor Adaptation (AMA). It is very rarely necessary to adjust the motor power factor parameter manually.
[3] Single fan/pump AEO	<i>Auto Energy Optimization VT</i> . For optimum energy efficient speed control of centrifugal pumps and fans. Provides a voltage which is optimized for a squared torque load characteristic of the motor but in addition the AEO feature will adapt the voltage exactly to the current load situation, thereby reducing

1-03 Torque Characteristics

Option:	Function:
	energy consumption and audible noise from the motor. To obtain optimal performance, the motor power factor cos phi must be set correctly. This value is set in par. 14-43, Motor cos phi. The parameter has a default value and is automatically adjusted when the motor data is programmed. These settings will typically ensure optimum motor voltage but if the motor power factor cos phi requires tuning, an AMA function can be carried out using par. 1-29, Automatic Motor Adaptation (AMA). It is very rarely necessary to adjust the motor power factor parameter manually.

1-20 Motor Power [kW]

Range:	Function:
4.00 kW* [0.09 - 3000.00 kW]	Enter the nominal motor power in kW according to the motor nameplate data. The default value corresponds to the nominal rated output of the unit. This parameter cannot be adjusted while the motor is running. Depending on the choices made in <i>0-03 Regional Settings</i> , either <i>1-20 Motor Power [kW]</i> or <i>1-21 Motor Power [HP]</i> is made invisible.

1-21 Motor Power [HP]

Range:	Function:
4.00 hp* [0.09 - 3000.00 hp]	Enter the nominal motor power in HP according to the motor nameplate data. The default value corresponds to the nominal rated output of the unit. This parameter cannot be adjusted while the motor is running. Depending on the choices made in <i>0-03 Regional Settings</i> , either <i>1-20 Motor Power [kW]</i> or <i>1-21 Motor Power [HP]</i> is made invisible.

1-22 Motor Voltage

Range:	Function:
500. V* [10. - 1000. V]	Enter the nominal motor voltage according to the motor nameplate data. The default value corresponds to the nominal rated output of the unit. This parameter cannot be adjusted while the motor is running.

1-23 Motor Frequency		
Range:		Function:
50. Hz*	[20 - 1000 Hz]	Select the motor frequency value from the motor nameplate data. For 87 Hz operation with 230/400 V motors, set the nameplate data for 230 V/50 Hz. Adapt <i>4-13 Motor Speed High Limit [RPM]</i> and <i>3-03 Maximum Reference</i> to the 87 Hz application.

NOTE

This parameter cannot be adjusted while the motor is running.

1-24 Motor Current		
Range:		Function:
7.20 A*	[0.10 - 10000.00 A]	Enter the nominal motor current value from the motor nameplate data. This data is used for calculating motor torque, motor thermal protection etc.

NOTE

This parameter cannot be adjusted while the motor is running.

1-25 Motor Nominal Speed		
Range:		Function:
1420. RPM*	[100 - 60000 RPM]	Enter the nominal motor speed value from the motor nameplate data. This data is used for calculating automatic motor compensations.

NOTE

This parameter cannot be adjusted while the motor is running.

1-39 Motor Poles														
Range:		Function:												
4. N/A*	[2 - 100 N/A]	Enter the number of motor poles.												
<table border="1"> <thead> <tr> <th>Poles</th> <th>~n_n@ 50 Hz</th> <th>~n_n@60 Hz</th> </tr> </thead> <tbody> <tr> <td>2</td> <td>2700 - 2880</td> <td>3250 - 3460</td> </tr> <tr> <td>4</td> <td>1350 - 1450</td> <td>1625 - 1730</td> </tr> <tr> <td>6</td> <td>700 - 960</td> <td>840 - 1153</td> </tr> </tbody> </table>			Poles	~n _n @ 50 Hz	~n _n @60 Hz	2	2700 - 2880	3250 - 3460	4	1350 - 1450	1625 - 1730	6	700 - 960	840 - 1153
Poles	~n _n @ 50 Hz	~n _n @60 Hz												
2	2700 - 2880	3250 - 3460												
4	1350 - 1450	1625 - 1730												
6	700 - 960	840 - 1153												
<p>The table shows the number of poles for normal speed ranges of various motor types. Define motors designed for other frequencies separately. The motor pole value is always an even number, because it refers to the total number of poles, not pairs of poles. The frequency converter creates the initial setting of <i>1-39 Motor Poles</i> based on <i>1-23 Motor Frequency</i> and <i>1-25 Motor Nominal Speed</i>.</p> <p>This parameter cannot be adjusted while the motor is running.</p>														

4-12 Motor Speed Low Limit [Hz]		
Range:		Function:
Application Dependent*	[0 - par. 4-14 Hz]	Enter the minimum limit for motor speed. The Motor Speed Low Limit can be set to correspond to the minimum output frequency of the motor shaft. The Speed Low Limit must not exceed the setting in <i>4-14 Motor Speed High Limit [Hz]</i> .

4-14 Motor Speed High Limit [Hz]		
Range:		Function:
50/60.0 Hz*	[par. 4-12 - par. 4-19 Hz]	Enter the maximum limit for motor speed. The Motor Speed High Limit can be set to correspond to the manufacturer's recommended maximum of the motor shaft. The Motor Speed High Limit must exceed the in <i>4-12 Motor Speed Low Limit [Hz]</i> . Only <i>4-11 Motor Speed Low Limit [RPM]</i> or <i>4-12 Motor Speed Low Limit [Hz]</i> will be displayed depending on other parameters in the Main Menu and depending on default settings dependant on global location.

NOTE

Max. output frequency cannot exceed 10% of the inverter switching frequency (*14-01 Switching Frequency*).

3-02 Minimum Reference		
Range:		Function:
0 ReferenceFeed-backUnit*	[-999999.999 - par. 3-03 ReferenceFeed-backUnit]	Enter the Minimum Reference. The Minimum Reference is the lowest value obtainable by summing all references. The Minimum Reference value and unit matches the configuration choice made in <i>1-00 Configuration Mode</i> and <i>20-12 Reference/Feedback Unit</i> , respectively.
<h3>NOTE</h3> <p>This parameter is used in open loop only.</p>		

3-03 Maximum Reference		
Range:	Function:	
0 ReferenceFeed-backUnit*	[par. 3-02 - 999999.999 ReferenceFeed-backUnit]	Enter the maximum acceptable value for the remote reference. The Maximum Reference value and unit matches the configuration choice made in <i>1-00 Configuration Mode</i> and <i>20-12 Reference/Feedback Unit</i> , respectively. NOTE If operating with <i>1-00 Configuration Mode</i> set for Closed Loop [3] , <i>20-14 Maximum Reference/Feedb.</i> must be used.

3-41 Ramp 1 Ramp Up Time		
Range:	Function:	
10.00 s*	[1.00 - 3600.00 s]	Enter the ramp-up time, i.e. the acceleration time from 0 RPM to <i>1-25 Motor Nominal Speed</i> . Choose a ramp-up time such that the output current does not exceed the current limit in <i>4-18 Current Limit</i> during ramping. See ramp-down time in <i>3-42 Ramp 1 Ramp Down Time</i> . $par.3 - 41 = \frac{tacc \times nnorm [par.1 - 25]}{ref[rpm]} [s]$

3-42 Ramp 1 Ramp Down Time		
Range:	Function:	
20.00 s*	[1.00 - 3600.00 s]	Enter the ramp-down time, i.e. the deceleration time from <i>1-25 Motor Nominal Speed</i> to 0 RPM. Choose a ramp-down time such that no over-voltage arises in the inverter due to regenerative operation of the motor, and such that the generated current does not exceed the current limit set in <i>4-18 Current Limit</i> . See ramp-up time in <i>3-41 Ramp 1 Ramp Up Time</i> . $par.3 - 42 = \frac{tdec \times nnorm [par.1 - 25]}{ref[rpm]} [s]$

3-13 Reference Site		
Option:	Function:	
		Select which reference site to activate.
[0] *	Linked to Hand / Auto	Use local reference when in Hand mode; or remote reference when in Auto mode.
[1]	Remote	Use remote reference in both Hand mode and Auto mode.

3-13 Reference Site		
Option:	Function:	
[2]	Local	Use local reference in both Hand mode and Auto mode. NOTE When set to Local [2], the frequency converter will start with this setting again following a 'power down'.

5-10 Terminal 18 Digital Input		
Option:	Function:	
[0]	No operation	No reaction to signals transmitted to terminal.
[1]	Reset	Resets frequency converter after a TRIP/ALARM. Not all alarms can be reset.
[2]	Coast inverse	Leaves motor in free mode. Logic '0' => coasting stop. (Default Digital input 27): Coasting stop, inverted input (NC).
[3]	Coast and reset inverse	Reset and coasting stop Inverted input (NC). Leaves motor in free mode and resets the frequency converter. Logic '0' => coasting stop and reset.
[5]	DC-brake inverse	Inverted input for DC braking (NC). Stops motor by energizing it with a DC current for a certain time period. See <i>2-01 DC Brake Current</i> to <i>2-03 DC Brake Cut In Speed [RPM]</i> . The function is only active when the value in <i>2-02 DC Braking Time</i> is different from 0. Logic '0' => DC braking.
[6]	Stop inverse	Stop Inverted function. Generates a stop function when the selected terminal goes from logical level '1' to '0'. The stop is performed according to the selected ramp time (<i>3-42 Ramp 1 Ramp Down Time</i> , <i>3-52 Ramp 2 Ramp Down Time</i> , par. 3-62, par. 3-72). NOTE When the frequency converter is at the torque limit and has received a stop command, it may not stop by itself. To ensure that the frequency converter stops, configure a digital output to <i>Torque limit & stop [27]</i> and connect this digital output to a digital input that is configured as coast.
[7]	External Interlock	Same function as Coasting stop, inverse, but External Interlock generates the alarm message 'external fault' on the display when the terminal which is programmed for Coast Inverse is logic '0'. The alarm message will also be active via digital outputs and relay outputs, if programmed

5-10 Terminal 18 Digital Input																																						
Option:	Function:																																					
		for External Interlock. The alarm can be reset using a digital input or the [RESET] key if the cause for the External Interlock has been removed. A delay can be programmed in <i>22-00 External Interlock Delay</i> , External Interlock Time. After applying a signal to the input, the reaction described above will be delayed with the time set in <i>22-00 External Interlock Delay</i> .																																				
[8] *	Start	Select start for a start/stop command. Logic '1' = start, logic '0' = stop. (Default Digital input 18)																																				
[9]	Latched start	Motor starts, if a pulse is applied for min. 2 ms. Motor stops when Stop inverse is activated																																				
[10]	Reversing	Changes direction of motor shaft rotation. Select Logic '1' to reverse. The reversing signal only changes the direction of rotation. It does not activate the start function. Select both directions in <i>4-10 Motor Speed Direction</i> . (Default Digital input 19).																																				
[11]	Start reversing	Used for start/stop and for reversing on the same wire. Signals on start are not allowed at the same time.																																				
[14]	Jog	Used for activating jog speed. See <i>3-11 Jog Speed [Hz]</i> . (Default Digital input 29)																																				
[15]	Preset reference on	Used for shifting between external reference and preset reference. It is assumed that <i>External/preset [1]</i> has been selected in <i>3-04 Reference Function</i> . Logic '0' = external reference active; logic '1' = one of the eight preset references is active.																																				
[16]	Preset ref bit 0	Enables a choice between one of the eight preset references according to the table below.																																				
[17]	Preset ref bit 1	Enables a choice between one of the eight preset references according to the table below.																																				
[18]	Preset ref bit 2	Enables a choice between one of the eight preset references according to the table below.																																				
		<table border="1"> <thead> <tr> <th>Preset ref. bit</th> <th>2</th> <th>1</th> <th>0</th> </tr> </thead> <tbody> <tr> <td>Preset ref. 0</td> <td>0</td> <td>0</td> <td>0</td> </tr> <tr> <td>Preset ref. 1</td> <td>0</td> <td>0</td> <td>1</td> </tr> <tr> <td>Preset ref. 2</td> <td>0</td> <td>1</td> <td>0</td> </tr> <tr> <td>Preset ref. 3</td> <td>0</td> <td>1</td> <td>1</td> </tr> <tr> <td>Preset ref. 4</td> <td>1</td> <td>0</td> <td>0</td> </tr> <tr> <td>Preset ref. 5</td> <td>1</td> <td>0</td> <td>1</td> </tr> <tr> <td>Preset ref. 6</td> <td>1</td> <td>1</td> <td>0</td> </tr> <tr> <td>Preset ref. 7</td> <td>1</td> <td>1</td> <td>1</td> </tr> </tbody> </table>	Preset ref. bit	2	1	0	Preset ref. 0	0	0	0	Preset ref. 1	0	0	1	Preset ref. 2	0	1	0	Preset ref. 3	0	1	1	Preset ref. 4	1	0	0	Preset ref. 5	1	0	1	Preset ref. 6	1	1	0	Preset ref. 7	1	1	1
Preset ref. bit	2	1	0																																			
Preset ref. 0	0	0	0																																			
Preset ref. 1	0	0	1																																			
Preset ref. 2	0	1	0																																			
Preset ref. 3	0	1	1																																			
Preset ref. 4	1	0	0																																			
Preset ref. 5	1	0	1																																			
Preset ref. 6	1	1	0																																			
Preset ref. 7	1	1	1																																			

5-10 Terminal 18 Digital Input		
Option:	Function:	
[19]	Freeze ref	Freezes actual reference. The frozen reference is now the point of enable/condition for Speed up and Speed down to be used. If Speed up/down is used, the speed change always follows ramp 2 (<i>3-51 Ramp 2 Ramp Up Time</i> and <i>3-52 Ramp 2 Ramp Down Time</i>) in the range 0 - <i>3-03 Maximum Reference</i> . (For closed loop see par. 20-14, Maximum Reference/Feedb.).
[20]	Freeze output	Freezes actual motor frequency (Hz). The frozen motor frequency is now the point of enable/condition for Speed up and Speed down to be used. If Speed up/down is used, the speed change always follows ramp 2 (<i>3-51 Ramp 2 Ramp Up Time</i> and <i>3-52 Ramp 2 Ramp Down Time</i>) in the range 0 - <i>1-23 Motor Frequency</i> . NOTE When Freeze output is active, the frequency converter cannot be stopped via a low 'start [13]' signal. Stop the frequency converter via a terminal programmed for Coasting inverse [2] or Coast and reset, inverse [3].
[21]	Speed up	For digital control of the up/down speed is desired (motor potentiometer). Activate this function by selecting either Freeze reference or Freeze output. When Speed up is activated for less than 400 msec. the resulting reference will be increased by 0.1 %. If Speed up is activated for more than 400 msec. the resulting reference will ramp according to Ramp 1 in <i>3-41 Ramp 1 Ramp Up Time</i> .
[22]	Speed down	Same as Speed up [21].
[23]	Set-up select bit 0	Selects one of the four set-ups. Set par. 0-10 to Multi Set-up.
[24]	Set-up select bit 1	Same as Set-up select bit 0 [23]. (Default Digital input 32)
[34]	Ramp bit 0	Select which ramp to use. Logic "0" will select ramp 1 while logic "1" will select ramp 2.
[36]	Mains failure inverse	Select to activate function selected in <i>14-10 Mains Failure</i> . Mains failure is active in the Logic "0" situation.
[39]	Day/ Night Control	
[52]	Run Permissive	The input terminal, for which the Run permissive has been programmed must be logic "1" before a start command can be accepted. Run permissive has a logic 'AND' function related to the terminal

5-10 Terminal 18 Digital Input		
Option:	Function:	
		which is programmed for <i>START</i> [8], <i>Jog</i> [14] or <i>Freeze Output</i> [20], which means that in order to start running the motor, both conditions must be fulfilled. If Run Permissive is programmed on multiple terminals, Run permissive needs only be logic '1' on one of the terminals for the function to be carried out. The digital output signal for Run Request (<i>Start</i> [8], <i>Jog</i> [14] or <i>Freeze output</i> [20]) programmed in par. 5-3*, or par. 5-4*, will not be affected by Run Permissive.
[53]	Hand start	A signal applied will put the frequency converter into Hand mode as if button <i>Hand On</i> on the LCP has been pressed and a normal stop command will be overridden. If disconnecting the signal, the motor will stop. To make any other start commands valid, another digital input must be assign to <i>Auto Start</i> and a signal applied to this. The <i>Hand On</i> and <i>Auto On</i> buttons on the LCP has no impact. The <i>Off</i> button on the LCP will override <i>Hand Start</i> and <i>Auto Start</i> . Press either the <i>Hand On</i> or <i>Auto On</i> button to make <i>Hand Start</i> and <i>Auto Start</i> active again. If no signal on neither <i>Hand Start</i> nor <i>Auto Start</i> , the motor will stop regardless of any normal Start command applied. If signal applied to both <i>Hand Start</i> and <i>Auto Start</i> , the function will be <i>Auto Start</i> . If pressing the <i>Off</i> button on the LCP the motor will stop regardless of signals on <i>Hand Start</i> and <i>Auto Start</i> .
[54]	Auto start	A signal applied will put the frequency converter into Auto mode as if the LCP button <i>Auto On</i> has been pressed. See also <i>Hand Start</i> [53]
[55]	DigiPot Increase	Uses the input as an INCREASE signal to the Digital Potentiometer function described in parameter group 3-9*
[56]	DigiPot Decrease	Uses the input as a DECREASE signal to the Digital Potentiometer function described in parameter group 3-9*
[57]	DigiPot Clear	Uses the input to CLEAR the Digital Potentiometer reference described in parameter group 3-9*
[62]	Reset Counter A	Input for reset of counter A.
[63]	Counter B (up)	(Terminal 29 and 33 only) Input for increment counting in the SLC counter.
[65]	Reset Counter B	Input for reset of counter B.
[66]	Sleep Mode	Forces frequency converter into Sleep Mode (see par. 22-4*).

5-10 Terminal 18 Digital Input		
Option:	Function:	
[78]	Reset Preventive Maintenance Word	Resets all data in 16-96 <i>Maintenance Word</i> to 0.
[120]	Lead Pump Start	Starts/ stops the lead pump (controlled by AKD 102).
[130]	Comp. 1 Interlock	The input signal must be low before the AKD 102 is able to start compressor 1.
[131]	Comp. 2 Interlock	The input signal must be low before the AKD 102 is able to start compressor 2.
[132]	Comp. 3 Interlock	The input signal must be low before the AKD 102 is able to start compressor 3.
[139]	Comp. 1 Inv. Interlock	The input signal must be high before the AKD 102 is able to start compressor 1.
[140]	Comp. 2 Inv. Interlock	The input signal must be high before the AKD 102 is able to start compressor 2.
[141]	Comp. 3 Inv. Interlock	The input signal must be high before the AKD 102 is able to start compressor 3.

1-29 Automatic Motor Adaptation (AMA)		
Option:	Function:	
		The AMA function optimizes dynamic motor performance by automatically optimizing the advanced motor parameters 1-30 <i>Stator Resistance (Rs)</i> to 1-35 <i>Main Reactance (Xh)</i> while the motor is stationary.
[0] *	Off	No function
[1]	Enable complete AMA	performs AMA of the stator resistance R_s , the rotor resistance R_r , the stator leakage reactance X_1 , the rotor leakage reactance X_2 and the main reactance X_h .
[2]	Enable reduced AMA	Performs a reduced AMA of the stator resistance R_s in the system only. Select this option if an LC filter is used between the frequency converter and the motor.

Activate the AMA function by pressing [Hand on] after selecting [1] or [2]. See also the item *Automatic Motor Adaptation* in the Design Guide. After a normal sequence, the display will read: "Press [OK] to finish AMA". After pressing the [OK] key the frequency converter is ready for operation.

NOTE:

- For the best adaptation of the frequency converter, run AMA on a cold motor
- AMA cannot be performed while the motor is running

NOTE

It is important to set motor par. 1-2* Motor Data correctly, since these form part of the AMA algorithm. An AMA must be performed to achieve optimum dynamic motor performance. It may take up to 10 min., depending on motor power rating.

NOTE

Avoid generating external torque during AMA.

NOTE

If one of the settings in par. 1-2* Motor Data is changed, 1-30 Stator Resistance (R_s) to 1-39 Motor Poles, the advanced motor parameters, will return to default setting. This parameter cannot be adjusted while the motor is running.

NOTE

Full AMA should be run without filter only while reduced AMA should be run with filter.

See section: *Application Examples > Automatic Motor Adaptation* in the Design Guide.

7.1.3 Function Setups

The Function set-up provides quick and easy access to all parameters required for the majority of ADAP-KOOL applications including most VAV and CAV supply and return fans, cooling tower fans, Primary, Secondary and Condenser Water Pumps and other pump, fan and compressor applications.

How to access Function Set-up - example

How to change the output on "Analog output 42"

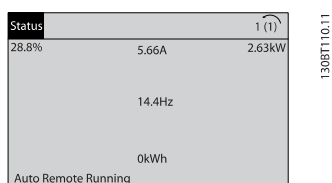

1308BT110.11

Illustration 7.2 Step 1: Turn on the frequency converter (yellow LED lights)

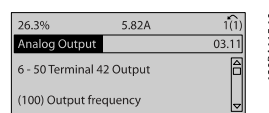

1308A115.10

Illustration 7.7 Step 6: Choose par. 6-50 Terminal 42 Output. Press [OK].

7

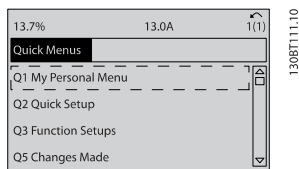

1308BT111.10

Illustration 7.3 Step 2: Press the [Quick Menus] button (Quick Menu choices appear).

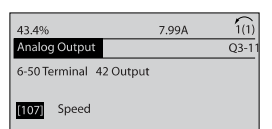

1308BT116.10

Illustration 7.8 Step 7: Use the up/down navigation keys to select between the different choices. Press [OK].

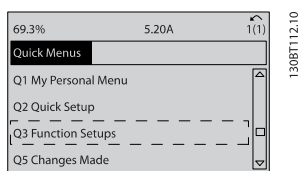

1308BT112.10

Illustration 7.4 Step 3: Use the up/down navigation keys to scroll down to Function Setups. Press [OK].

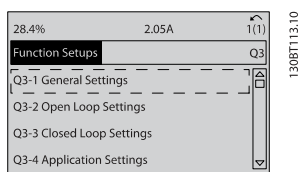

1308BT113.10

Illustration 7.5 Step 4: Function Setups choices appear. Choose 03-1 General Settings. Press [OK].

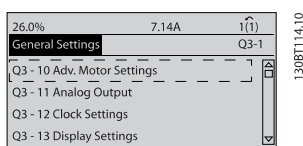

1308BT114.10

Illustration 7.6 Step 5: Use the up/down navigation keys to scroll down to i.e. par. 03-11 Analog Outputs. Press [OK].

The Function Setup parameters are grouped in the following way:

Q3-1 General Settings			
Q3-10 Adv. Motor Settings	Q3-11 Analog Output	Q3-12 Clock Settings	Q3-13 Display Settings
1-90 Motor Thermal Protection	6-50 Terminal 42 Output	0-70 Set date and time	0-20 Display Line 1.1 Small
1-93 Thermistor Source	6-51 Terminal 42 Output min. scale	0-71 Date format	0-21 Display Line 1.2 Small
1-29 Automatic Motor Adaption	6-52 Terminal 42 Output max. scale	0-72 Time format	0-22 Display Line 1.3 Small
14-01 Switching Frequency		0-74 DST/Summertime	0-23 Display Line 2 large
		0-76 DST/Summertime start	0-24 Display Line 3 large
		0-77 DST/Summertime end	0-37 Display Text 1
			0-38 Display Text 2
			0-39 Display Text 3

Q3-2 Open Loop Settings
1-00 Configuration Mode
3-02 Minimum Reference
3-03 Maximum reference
3-15 Reference 1 Source
6-10 Terminal 53 Low Voltage
6-11 Terminal 53 High Voltage
6-14 Terminal 53 Low Reference / Feedb. value
6-15 Terminal 53 High ref / Feed. value
3-10 Preset reference

Q3-3 Closed Loop Settings
1-00 Configuration mode
20-00 Feedback 1 Source
20-12 Reference/Feedback Unit
6-20 Term 54 low voltage
6-21 Term 54 high voltage
6-22 Terminal 54 Low Current (only visible if switch set to I)
6-23 Terminal 54 High Current (only visible if switch set to I)
6-24 Terminal 54 Low ref / Feedb. value
6-25 Terminal 54 High ref / Feedb. value
3-02 Min. Reference
3-03 Max. Reference
20-21 Setpoint 1
20-93 PID Proportional Gain
20-94 PID Integral Time
3-13 Reference site

Q3-4 Application Settings		
Compressor	Condenser	Single fan/ pump
22-75 Short Cycle Protection	22-40 Minimum run time	22-40 Minimum run time
22-76 Interval between Starts	22-41 Minimum sleep time	22-41 Minimum sleep time
22-77 Minimum Run Time	22-42 Wake-up Speed [RPM]	22-42 Wake-up Speed [RPM]
20-00 Feedback 1 Source	22-43 Wake-up Speed [Hz]	22-43 Wake-up Speed [Hz]
20-01 Feedback 1 Conversion	22-44 Wake up ref. /FB difference	22-44 Wake up ref. /FB difference
20-02 Feedback 1 Source Unit	20-00 Feedback 1 Source	
20-30 Refrigerant	20-01 Feedback 1 Conversion	
20-40 ThermostatPressostat	20-02 Feedback 1 Source Unit	
20-41 Cut-out value	20-30 Refrigerant	
20-42 Cut-in value	20-40 ThermostatPressostat	
25-00 Pack Controller	20-41 Cut-out value	
25-06 Number of compressors	20-42 Cut-in value	
25-20 Neutral zone		
25-21 +zone		
25-22 -zone		

See also ADAP-KOOL® Drive AKD102 Programming Guide for a detailed description of the Function Setups parameter groups.

0-20 Display Line 1.1 Small		
Option:		Function:
		Select a variable for display in line 1, left position.
[0]	None	No display value selected
[37]	Display Text 1	Present control word
[38]	Display Text 2	Enables an individual text string to be written, for display in the LCP or to be read via serial communication.
[39]	Display Text 3	Enables an individual text string to be written, for display in the LCP or to be read via serial communication.
[89]	Date and Time Readout	Displays the current date and time.
[953]	Profibus Warning Word	Displays Profibus communication warnings.
[1005]	Readout Transmit Error Counter	View the number of CAN control transmission errors since the last power-up.
[1006]	Readout Receive Error Counter	View the number of CAN control receipt errors since the last power-up.
[1007]	Readout Bus Off Counter	View the number of Bus Off events since the last power-up.
[1013]	Warning Parameter	View a DeviceNet-specific warning word. One separate bit is assigned to every warning.
[1115]	LON Warning Word	Shows the LON-specific warnings.
[1117]	XIF Revision	Shows the version of the external interface file of the Neuron C chip on the LON option.
[1118]	LON Works Revision	Shows the software version of the application program of the Neuron C chip on the LON option.
[1501]	Running Hours	View the number of running hours of the motor.
[1502]	kWh Counter	View the mains power consumption in kWh.
[1600]	Control Word	View the Control Word sent from the frequency converter via the serial communication port in hex code.
[1601]	Reference [Unit]	Total reference (sum of digital/analog/preset/bus/freeze ref./catch up and slow-down) in selected unit.
[1602] *	Reference %	Total reference (sum of digital/analog/preset/bus/freeze ref./catch up and slow-down) in percent.
[1603]	Status Word	Present status word
[1605]	Main Actual Value [%]	One or more warnings in a Hex code
[1609]	Custom Readout	View the user-defined readouts as defined in par. 0-30, 0-31 and 0-32.

0-20 Display Line 1.1 Small		
Option:		Function:
[1610]	Power [kW]	Actual power consumed by the motor in kW.
[1611]	Power [hp]	Actual power consumed by the motor in HP.
[1612]	Motor Voltage	Voltage supplied to the motor.
[1613]	Motor Frequency	Motor frequency, i.e. the output frequency from the frequency converter in Hz.
[1614]	Motor Current	Phase current of the motor measured as effective value.
[1615]	Frequency [%]	Motor frequency, i.e. the output frequency from the frequency converter in percent.
[1616]	Torque [Nm]	Present motor load as a percentage of the rated motor torque.
[1617]	Speed [RPM]	Speed in RPM (motor shaft speed in revolutions per minute). The accuracy is dependent on the set slip compensation, par. 1-62 or on the motor speed feedback - if available.
[1618]	Motor Thermal	Thermal load on the motor, calculated by the ETR function. See also parameter group 1-9* Motor Temperature.
[1622]	Torque [%]	Shows the actual torque produced, in percentage.
[1630]	DC Link Voltage	Intermediate circuit voltage in the frequency converter.
[1632]	BrakeEnergy/s	Present brake power transferred to an external brake resistor. Stated as an instantaneous value.
[1633]	BrakeEnergy/2 min	Brake power transferred to an external brake resistor. The mean power is calculated continuously for the most recent 120 seconds.
[1634]	Heatsink Temp.	Present heat sink temperature of the frequency converter. The cut-out limit is 95 ±5 °C; cutting back in occurs at 70 ±5° C.
[1635]	Thermal Drive Load	Percentage load of the inverters
[1636]	Inv. Nom. Current	Nominal current of the frequency converter
[1637]	Inv. Max. Current	Maximum current of the frequency converter
[1638]	SL Control State	State of the event executed by the control
[1639]	Control Card Temp.	Temperature of the control card.
[1650]	External Reference	Sum of the external reference as a percentage, i.e. the sum of analog/pulse/bus.

0-20 Display Line 1.1 Small		
Option:	Function:	
[1652]	Feedback [Unit]	Reference value from programmed digital input(s).
[1653]	Digi Pot Reference	View the contribution of the digital potentiometer to the actual reference Feedback.
[1654]	Feedback 1 [Unit]	View the value of Feedback 1. See also par. 20-0*.
[1655]	Feedback 2 [Unit]	View the value of Feedback 2. See also par. 20-0*.
[1656]	Feedback 3 [Unit]	View the value of Feedback 3. See also par. 20-0*.
[1660]	Digital Input	Displays the status of the digital inputs. Signal low = 0; Signal high = 1. Regarding order, see par. 16-60. Bit 0 is at the extreme right.
[1661]	Terminal 53 Switch Setting	Setting of input terminal 53. Current = 0; Voltage = 1.
[1662]	Analog Input 53	Actual value at input 53 either as a reference or protection value.
[1663]	Terminal 54 Switch Setting	Setting of input terminal 54. Current = 0; Voltage = 1.
[1664]	Analog Input 54	Actual value at input 54 either as reference or protection value.
[1665]	Analog Output 42 [mA]	Actual value at output 42 in mA. Use par. 6-50 to select the variable to be represented by output 42.
[1666]	Digital Output [bin]	Binary value of all digital outputs.
[1667]	Freq. Input #29 [Hz]	Actual value of the frequency applied at terminal 29 as a pulse input.
[1668]	Freq. Input #33 [Hz]	Actual value of the frequency applied at terminal 33 as a pulse input.
[1669]	Pulse Output #27 [Hz]	Actual value of pulses applied to terminal 27 in digital output mode.
[1670]	Pulse Output #29 [Hz]	Actual value of pulses applied to terminal 29 in digital output mode.
[1671]	Relay Output [bin]	View the setting of all relays.
[1672]	Counter A	View the present value of Counter A.
[1673]	Counter B	View the present value of Counter B.
[1675]	Analog input X30/11	Actual value of the signal on input X30/11 (General Purpose I/O Card. Option)
[1676]	Analog input X30/12	Actual value of the signal on input X30/12 (General Purpose I/O Card. Optional)
[1677]	Analog output X30/8 [mA]	Actual value at output X30/8 (General Purpose I/O Card. Optional) Use Par. 6-60 to select the variable to be shown.

0-20 Display Line 1.1 Small		
Option:	Function:	
[1680]	Fieldbus CTW 1	Control word (CTW) received from the Bus Master.
[1682]	Fieldbus REF 1	Main reference value sent with control word via the serial communications network e.g. from the BMS, PLC or other master controller.
[1684]	Comm. Option STW	Extended fieldbus communication option status word.
[1685]	FC Port CTW 1	Control word (CTW) received from the Bus Master.
[1686]	FC Port REF 1	Status word (STW) sent to the Bus Master.
[1690]	Alarm Word	One or more alarms in a Hex code (used for serial communications)
[1691]	Alarm Word 2	One or more alarms in a Hex code (used for serial communications)
[1692]	Warning Word	One or more warnings in a Hex code (used for serial communications)
[1693]	Warning Word 2	One or more warnings in a Hex code (used for serial communications)
[1694]	Ext. Status Word	One or more status conditions in a Hex code (used for serial communications)
[1695]	Ext. Status Word 2	One or more status conditions in a Hex code (used for serial communications)
[1696]	Maintenance Word	The bits reflect the status for the programmed Preventive Maintenance Events in parameter group 23-1*
[1830]	Analog Input X42/1	Shows the value of the signal applied to terminal X42/1 on the Analog I/O card.
[1831]	Analog Input X42/3	Shows the value of the signal applied to terminal X42/3 on the Analog I/O card.
[1832]	Analog Input X42/5	Shows the value of the signal applied to terminal X42/5 on the Analog I/O card.
[1833]	Analog Out X42/7 [V]	Shows the value of the signal applied to terminal X42/7 on the Analog I/O card.
[1834]	Analog Out X42/9 [V]	Shows the value of the signal applied to terminal X42/9 on the Analog I/O card.
[1835]	Analog Out X42/11 [V]	Shows the value of the signal applied to terminal X42/11 on the Analog I/O card.
[2117]	Ext. 1 Reference [Unit]	The value of the reference for extended Closed Loop Controller 1

0-20 Display Line 1.1 Small		
Option:	Function:	
[2118]	Ext. 1 Feedback [Unit]	The value of the feedback signal for extended Closed Loop Controller 1
[2119]	Ext. 1 Output [%]	The value of the output from extended Closed Loop Controller 1
[2137]	Ext. 2 Reference [Unit]	The value of the reference for extended Closed Loop Controller 2
[2138]	Ext. 2 Feedback [Unit]	The value of the feedback signal for extended Closed Loop Controller 2
[2139]	Ext. 2 Output [%]	The value of the output from extended Closed Loop Controller 2
[2157]	Ext. 3 Reference [Unit]	The value of the reference for extended Closed Loop Controller 3
[2158]	Ext. 3 Feedback [Unit]	The value of the feedback signal for extended Closed Loop Controller 3
[2159]	Ext. 3 Output [%]	The value of the output from extended Closed Loop Controller 3
[2230]	No-Flow Power	The calculated No Flow Power for the actual operating speed
[2580]	Pack Status	Status for the operation of the Pack Controller
[2581]	Compressor Status	Status for the operation of each individual compressor controlled by the Pack Controller

0-21 Display Line 1.2 Small		
The options are the same as those listed for par 0-20 Display Line 1.1 Small		
Option:	Function:	
	Select a variable for display in line 1, middle position.	

0-22 Display Line 1.3 Small		
The options are the same as those listed for par 0-20 Display Line 1.1 Small		
Option:	Function:	
	Select a variable for display in line 1, right position.	

0-23 Display Line 2 Large		
The options are the same as those listed for par 0-20 Display Line 1.1 Small		
Option:	Function:	
	Select a variable for display in line 2.	

0-24 Display Line 3 Large		
The options are the same as those listed for par 0-20 Display Line 1.1 Small		
Option:	Function:	
	Select a variable for display in line 3.	

0-37 Display Text 1		
Range:	Function:	
0 N/A*	[0 - 0 N/A]	In this parameter it is possible to write an individual text string for display in the LCP or to be read via serial communication. If to be displayed permanently select Display Text 1 in 0-20 Display Line 1.1 Small, 0-21 Display Line 1.2 Small, 0-22 Display Line 1.3 Small, 0-23 Display Line 2 Large or 0-24 Display Line 3 Large. Use the ▲ or ▼ buttons on the LCP to change a character. Use the ◀ and ▶ buttons to move the cursor. When a character is highlighted by the cursor, it can be changed. Use the ▲ or ▼ buttons on the LCP to change a character. A character can be inserted by placing the cursor between two characters and pressing ▲ or ▼.

0-38 Display Text 2		
Range:	Function:	
0 N/A*	[0 - 0 N/A]	In this parameter it is possible to write an individual text string for display in the LCP or to be read via serial communication. If to be displayed permanently select Display Text 2 in 0-20 Display Line 1.1 Small, 0-21 Display Line 1.2 Small, 0-22 Display Line 1.3 Small, 0-23 Display Line 2 Large or 0-24 Display Line 3 Large. Use the ▲ or ▼ buttons on the LCP to change a character. Use the ◀ and ▶ buttons to move the cursor. When a character is highlighted by the cursor, this character can be changed. A character can be inserted by placing the cursor between two characters and pressing ▲ or ▼.

0-39 Display Text 3		
Range:	Function:	
0 N/A*	[0 - 0 N/A]	In this parameter it is possible to write an individual text string for display in the LCP or to be read via serial communication. If to be displayed permanently select Display Text 3 in 0-20 Display Line 1.1 Small, 0-21 Display Line 1.2 Small, 0-22 Display Line 1.3 Small, 0-23 Display Line 2 Large or 0-24 Display Line 3 Large. Use the ▲ or ▼ buttons on the LCP to change a character. Use the ◀ and ▶ buttons to move the cursor. When a character is highlighted by the cursor, this character can be changed. A character can be inserted by placing the cursor between two characters and pressing ▲ or ▼.

0-70 Set Date and Time		
Range:	Function:	
0 N/A*	[0 - 0 N/A]	Sets the date and time of the internal clock. The format to be used is set in 0-71 Date Format and 0-72 Time Format.

0-71 Date Format		
Option:	Function:	
		Sets the date format to be used in the LCP.
[0] *	YYYY-MM-DD	
[1] *	DD-MM-YYYY	
[2]	MM/DD/YYYY	

0-72 Time Format		
Option:	Function:	
		Sets the time format to be used in the LCP.
[0] *	24 h	
[1]	12 h	

0-74 DST/Summertime		
Option:	Function:	
		Choose how Daylight Saving Time/Summertime should be handled. For manual DST/Summertime enter the start date and end date in 0-76 DST/Summertime Start and 0-77 DST/Summertime End.
[0] *	Off	
[2]	Manual	

0-76 DST/Summertime Start		
Range:	Function:	
0 N/A*	[0 - 0 N/A]	Sets the date and time when summertime/DST starts. The date is

0-76 DST/Summertime Start		
Range:	Function:	
		programmed in the format selected in 0-71 Date Format.

0-77 DST/Summertime End		
Range:	Function:	
0 N/A*	[0 - 0 N/A]	Sets the date and time when summertime/DST ends. The date is programmed in the format selected in 0-71 Date Format.

1-00 Configuration Mode		
Option:	Function:	
[0] *	Open loop	Motor speed is determined by applying a speed reference or by setting desired speed when in Hand Mode. Open Loop is also used if the frequency converter is part of a closed loop control system based on an external PID controller providing a speed reference signal as output.
[3]	Closed loop	Motor Speed will be determined by a reference from the built-in PID controller varying the motor speed as part of a closed loop control process (e.g. constant pressure or flow). The PID controller must be configured in par. group 20-**, Drive Closed Loop or via the Function Setups accessed by pressing the [Quick Menus] button.

This parameter can not be changed when motor is running.

NOTE

When set for Closed Loop, the commands Reversing and Start Reversing will not reverse the direction of the motor.

1-90 Motor Thermal Protection		
Option:	Function:	
		The frequency converter determines the motor temperature for motor protection in two different ways: <ul style="list-style-type: none"> Via a thermistor sensor connected to one of the analog or digital inputs (1-93 Thermistor Source). Via calculation (ETR = Electronic Thermal Relay) of the thermal load, based on the actual load and time. The calculated thermal load is compared with the rated motor current $I_{M,N}$ and the rated motor frequency $f_{M,N}$. The calculations estimate the need for a lower load at lower speed due to less cooling from the fan incorporated in the motor.

1-90 Motor Thermal Protection		
Option:	Function:	
[0] *	No protection	If the motor is continuously overloaded and no warning or trip of frequency converter is wanted.
[1]	Thermistor warning	Activates a warning when the connected thermistor in the motor reacts in the event of motor over-temperature.
[2]	Thermistor trip	Stops (trips) the frequency converter when the connected thermistor in the motor reacts in the event of motor over-temperature.
[3]	ETR warning 1	
[4] *	ETR trip 1	
[5]	ETR warning 2	
[6]	ETR trip 2	
[7]	ETR warning 3	
[8]	ETR trip 3	
[9]	ETR warning 4	
[10]	ETR trip 4	

ETR (Electronic Thermal Relay) functions 1-4 will calculate the load when set-up where they were selected is active.

For example ETR-3 starts calculating when set-up 3 is selected. For the North American market: The ETR functions provide class 20 motor overload protection in accordance with NEC.

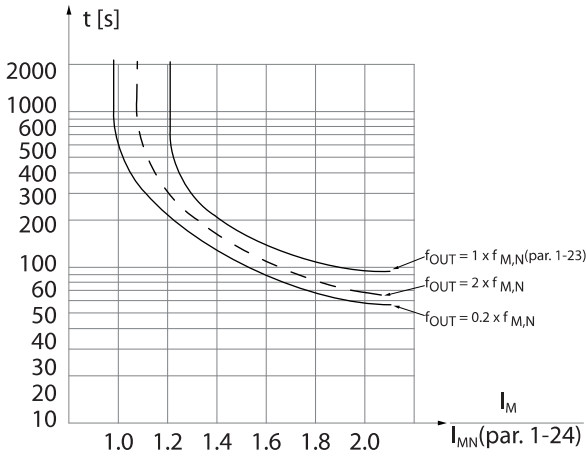

7

NOTE

Danfoss recommends using 24 VDC as thermistor supply voltage.

1-93 Thermistor Source	
Option:	Function:
[0] *	None
[1]	Analog input 53
[2]	Analog input 54
[3]	Digital input 18
[4]	Digital input 19
[5]	Digital input 32
[6]	Digital input 33

NOTE

This parameter cannot be adjusted while the motor is running.

NOTE

Digital input should be set to [0] PNP - Active at 24V in par. 5-00.

3-10 Preset Reference		
Array [8]		
Range:	Function:	
0.00 %*	[-100.00 - 100.00 %]	Enter up to eight different preset references (0-7) in this parameter, using array programming. The preset reference is stated as a percentage of the value Ref _{MAX} (3-03 Maximum Reference, for closed loop see 20-14 Maximum Reference/Feedb.). When using preset references, select Preset ref. bit 0 / 1 / 2 [16], [17] or [18] for the corresponding digital inputs in parameter group 5-1* Digital Inputs.

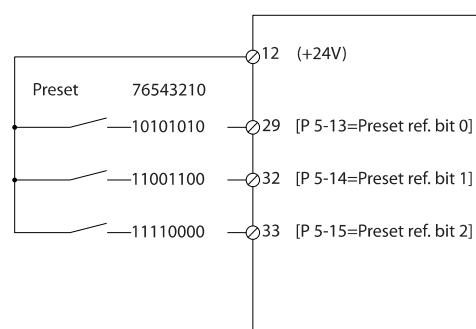
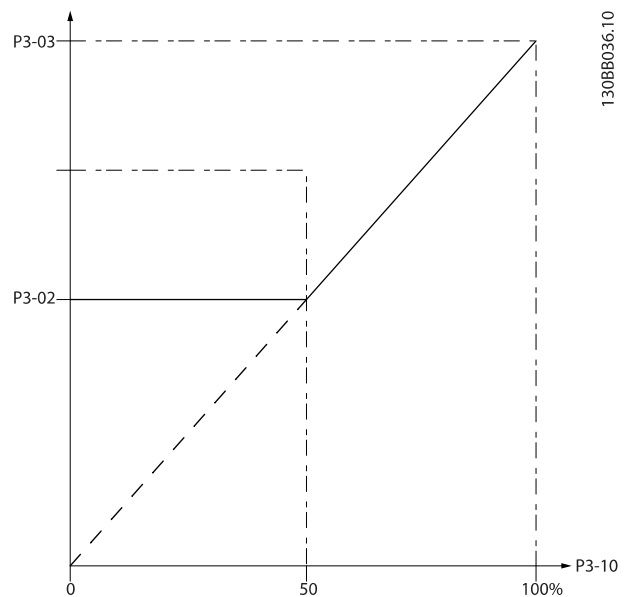

3-13 Reference Site		
Option:	Function:	
		Select which reference site to activate.
[0] *	Linked to Hand / Auto	Use local reference when in Hand mode; or remote reference when in Auto mode.
[1]	Remote	Use remote reference in both Hand mode and Auto mode.
[2]	Local	Use local reference in both Hand mode and Auto mode. NOTE When set to Local [2], the frequency converter will start with this setting again following a 'power down'.

3-15 Reference 1 Source		
Option:	Function:	
		Select the reference input to be used for the first reference signal. <i>3-15 Reference 1 Source, 3-16 Reference 2 Source and 3-17 Reference 3 Source</i> define up to three different reference signals. The sum of these reference signals defines the actual reference. This parameter cannot be adjusted while the motor is running.
[0]	No function	
[1] *	Analog input 53	
[2]	Analog input 54	
[7]	Pulse input 29	
[8]	Pulse input 33	
[20]	Digital pot.meter	
[21]	Analog input X30/11	
[22]	Analog input X30/12	
[23]	Analog Input X42/1	
[24]	Analog Input X42/3	
[25]	Analog Input X42/5	
[30]	Ext. Closed Loop 1	
[31]	Ext. Closed Loop 2	
[32]	Ext. Closed Loop 3	

6-10 Terminal 53 Low Voltage		
Range:	Function:	
0.07 V* [0.00 - par. 6-11 V]	Enter the low voltage value. This analog input scaling value should correspond to the low reference/feedback value set in <i>6-14 Terminal 53 Low Ref./Feedb. Value</i> .	

6-11 Terminal 53 High Voltage		
Range:	Function:	
10.00 V* [par. 6-10 - 10.00 V]	Enter the high voltage value. This analog input scaling value should correspond to the high reference/	

6-11 Terminal 53 High Voltage		
Range:	Function:	
	feedback value set in <i>6-15 Terminal 53 High Ref./Feedb. Value</i> .	

6-14 Terminal 53 Low Ref./Feedb. Value		
Range:	Function:	
0.000 N/A* [-999999.999 - 999999.999 N/A]	Enter the analog input scaling value that corresponds to the low voltage/low current set in <i>6-10 Terminal 53 Low Voltage</i> and <i>6-12 Terminal 53 Low Current</i> .	

6-15 Terminal 53 High Ref./Feedb. Value		
Range:	Function:	
100.000 N/A* [-999999.999 - 999999.999 N/A]	Enter the analog input scaling value that corresponds to the high voltage/high current value set in <i>6-11 Terminal 53 High Voltage</i> and <i>6-13 Terminal 53 High Current</i> .	

6-20 Terminal 54 Low Voltage		
Range:	Function:	
0.07 V* [0.00 - par. 6-21 V]	Enter the low voltage value. This analog input scaling value should correspond to the low reference/feedback value, set in <i>6-24 Terminal 54 Low Ref./Feedb. Value</i> .	

6-21 Terminal 54 High Voltage		
Range:	Function:	
10.00 V* [par. 6-20 - 10.00 V]	Enter the high voltage value. This analog input scaling value should correspond to the high reference/feedback value set in <i>6-25 Terminal 54 High Ref./Feedb. Value</i> .	

6-22 Terminal 54 Low Current		
Range:	Function:	
4.00 mA* [0.00 - par. 6-23 mA]	Enter the low current value. This reference signal should correspond to the low reference/feedback value, set in <i>6-24 Terminal 54 Low Ref./Feedb. Value</i> . The value must be set at >2 mA in order to activate the Live Zero Time-out Function in <i>6-01 Live Zero Timeout Function</i> .	

6-23 Terminal 54 High Current		
Range:	Function:	
20.00 mA* [par. 6-22 - 20.00 mA]	Enter the high current value corresponding to the high reference/feedback value set in <i>6-25 Terminal 54 High Ref./Feedb. Value</i> .	

6-24 Terminal 54 Low Ref./Feedb. Value		
Range:		Function:
-1.000 N/A*	[-999999.999 - 999999.999 N/A]	Enter the analog input scaling value that corresponds to the low voltage/low current value set in 6-20 Terminal 54 Low Voltage and 6-22 Terminal 54 Low Current.

6-25 Terminal 54 High Ref./Feedb. Value		
Range:		Function:
Application Dependent*	[-999999.999 - 999999.999 N/A]	Enter the analog input scaling value that corresponds to the high voltage/high current value set in 6-21 Terminal 54 High Voltage and 6-23 Terminal 54 High Current.

6-50 Terminal 42 Output		
Option:	Function:	
[0] *	No operation	
[100] *	Output frequency	: 0 - 100 Hz, (0-20 mA)
[101]	Reference	: Minimum reference - Maximum reference, (0-20 mA)
[102]	Feedback	: -200% to +200% of 20-14 Maximum Reference/Feedb., (0-20 mA)
[103]	Motor current	: 0 - Inverter Max. Current (16-37 Inv. Max. Current), (0-20 mA)
[104]	Torque rel to limit	: 0 - Torque limit (4-16 Torque Limit Motor Mode), (0-20 mA)
[105]	Torq relate to rated	: 0 - Motor rated torque, (0-20 mA)
[106]	Power	: 0 - Motor rated power, (0-20 mA)
[107] *	Speed	: 0 - Speed High Limit (4-13 Motor Speed High Limit [RPM] and 4-14 Motor Speed High Limit [Hz]), (0-20 mA)
[108]	Torque	
[109]	Max Out Freq	
[113]	Ext. Closed Loop 1	: 0 - 100%, (0-20 mA)
[114]	Ext. Closed Loop 2	: 0 - 100%, (0-20 mA)
[115]	Ext. Closed Loop 3	: 0 - 100%, (0-20 mA)
[130]	Output freq. 4-20mA	: 0 - 100 Hz
[131]	Reference 4-20mA	: Minimum Reference - Maximum Reference

6-50 Terminal 42 Output		
Option:	Function:	
[132]	Feedback 4-20mA	: -200% to +200% of 20-14 Maximum Reference/Feedb.
[133]	Motor cur. 4-20mA	: 0 - Inverter Max. Current (16-37 Inv. Max. Current)
[134]	Torq.% lim 4-20 mA	: 0 - Torque limit (4-16 Torque Limit Motor Mode)
[135]	Torq.% nom 4-20mA	: 0 - Motor rated torque
[136]	Power 4-20mA	: 0 - Motor rated power
[137]	Speed 4-20mA	: 0 - Speed High Limit (4-13 and 4-14)
[138]	Torque 4-20mA	
[139]	Bus ctrl.	: 0 - 100%, (0-20 mA)
[140]	Bus ctrl. 4-20 mA	: 0 - 100%
[141]	Bus ctrl t.o.	: 0 - 100%, (0-20 mA)
[142]	Bus ctrl t.o. 4-20mA	: 0 - 100%
[143]	Ext. CL 1 4-20mA	: 0 - 100%
[144]	Ext. CL 2 4-20mA	: 0 - 100%
[145]	Ext. CL 3 4-20mA	: 0 - 100%
[150]	Max Out Fr 4-20 mA	

NOTE

Values for setting the Minimum Reference is found in open loop 3-02 Minimum Reference and for closed loop 20-13 Minimum Reference/Feedb. - values for maximum reference for open loop is found in 3-03 Maximum Reference and for closed loop 20-14 Maximum Reference/Feedb..

6-51 Terminal 42 Output Min Scale		
Range:		Function:
0.00 %*	[0.00 - 200.00 %]	Scale for the minimum output (0 or 4 mA) of the analogue signal at terminal 42. Set the value to be the percentage of the full range of the variable selected in 6-50 Terminal 42 Output.

6-52 Terminal 42 Output Max Scale	
Range:	Function:
100.00 %* - 200.00 %]	<p>Scale for the maximum output (20 mA) of the analog signal at terminal 42.</p> <p>Set the value to be the percentage of the full range of the variable selected in 6-50 Terminal 42 Output.</p> <div style="text-align: center;"> <p>130BA075.12</p> </div> <p>0% Analogue output Min Scale par. 6-93 100% Variable output for output example: Speed (RPM)</p> <p>It is possible to get a value lower than 20 mA at full scale by programming values >100% by using a formula as follows:</p> $20 \text{ mA} / \text{desired maximum current} \times 100 \%$ <p>i.e. $10 \text{ mA} : \frac{20 \text{ mA}}{10 \text{ mA}} \times 100 \% = 200 \%$</p>

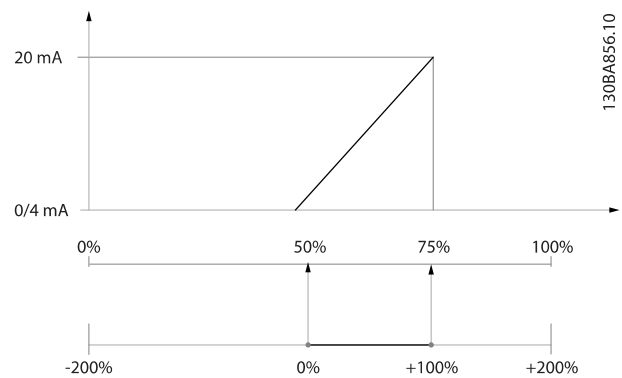

EXAMPLE 3:

Variable value= REFERENCE, range= Min ref - Max ref

Range needed for output= Min ref (0%) - Max ref (100%), 0-10 mA

Output signal 0 or 4 mA is needed at Min ref - set 6-51 Terminal 42 Output Min Scale to 0%

Output signal 10 mA is needed at Max ref (100% of range) - set 6-52 Terminal 42 Output Max Scale to 200% (20 mA / 10 mA x 100%=200%).

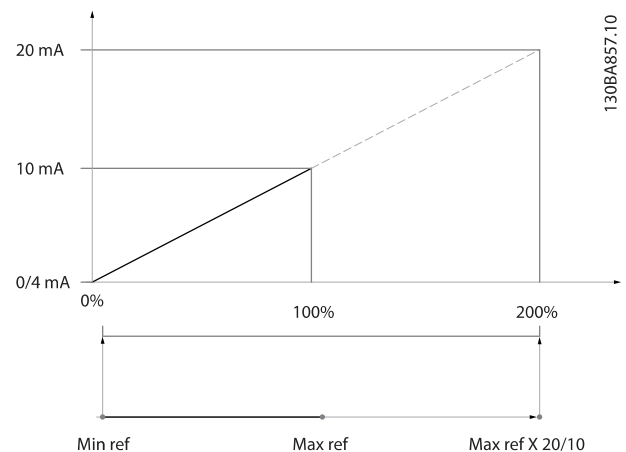

EXAMPLE 1:

Variable value= OUTPUT FREQUENCY, range = 0-100 Hz

Range needed for output = 0-50 Hz

Output signal 0 or 4 mA is needed at 0 Hz (0% of range) - set 6-51 Terminal 42 Output Min Scale to 0%

Output signal 20 mA is needed at 50 Hz (50% of range) - set 6-52 Terminal 42 Output Max Scale to 50%

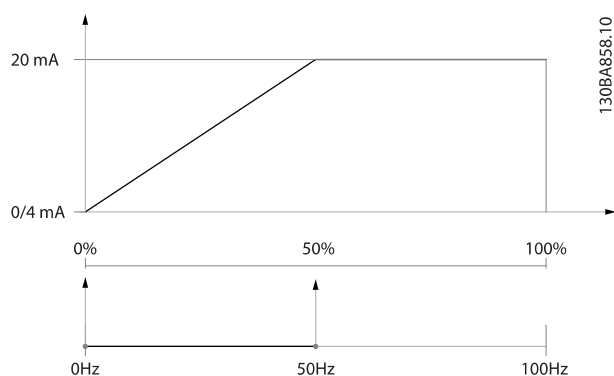

EXAMPLE 2:

Variable= FEEDBACK, range= -200% to +200%

Range needed for output= 0-100%

Output signal 0 or 4 mA is needed at 0% (50% of range) - set 6-51 Terminal 42 Output Min Scale to 50%

Output signal 20 mA is needed at 100% (75% of range) - set 6-52 Terminal 42 Output Max Scale to 75%

14-01 Switching Frequency

Option: **Function:**

Select the inverter switching frequency. Changing the switching frequency can help to reduce acoustic noise from the motor.

NOTE

The output frequency value of the frequency converter must never exceed 1/10 of the switching frequency. When the motor is running, adjust the switching frequency in 14-01 Switching Frequency until the motor is as noiseless as possible. See also 14-00 Switching Pattern and the section Derating.

[0]	1.0 kHz
[1]	1.5 kHz

14-01 Switching Frequency		
Option:	Function:	
[2]	2.0 kHz	
[3]	2.5 kHz	
[4]	3.0 kHz	
[5]	3.5 kHz	
[6]	4.0 kHz	
[7] *	5.0 kHz	
[8]	6.0 kHz	
[9]	7.0 kHz	
[10]	8.0 kHz	
[11]	10.0 kHz	
[12]	12.0 kHz	
[13]	14.0 kHz	
[14]	16.0 kHz	

20-00 Feedback 1 Source		
Option:	Function:	
		Up to three different feedback signals can be used to provide the feedback signal for the frequency converter's PID Controller. This parameter defines which input will be used as the source of the first feedback signal. Analog input X30/11 and Analog input X30/12 refer to inputs on the optional General Purpose I/O board.
[0]	No function	
[1]	Analog input 53	
[2] *	Analog input 54	
[3]	Pulse input 29	
[4]	Pulse input 33	
[7]	Analog input X30/11	
[8]	Analog input X30/12	
[9]	Analog Input X42/1	
[10]	Analog Input X42/3	
[11]	Analog Input X42/5	
[100]	Bus feedback 1	
[101]	Bus feedback 2	
[102]	Bus feedback 3	

NOTE

If a feedback is not used, its source must be set to **No Function** [0]. **20-20 Feedback Function** determines how the three possible feedbacks will be used by the PID Controller.

20-01 Feedback 1 Conversion

This parameter allows a conversion function to be applied to Feedback 1.

Option: **Function:**

[0]	Linear	Linear [0] has no effect on the feedback.
-----	--------	-------------------------------------------

20-01 Feedback 1 Conversion

This parameter allows a conversion function to be applied to Feedback 1.

Option: **Function:**

[1]	Square root	<i>Square root</i> [1] is commonly used when a pressure sensor is used to provide flow feedback ($flow \propto \sqrt{pressure}$).
[2] *	Pressure to temperature	<i>Pressure to temperature</i> [2] is used in compressor applications to provide temperature feedback using a pressure sensor. The temperature of the refrigerant is calculated using the following formula: $Temperature = \frac{A2}{(ln(Pe + 1) - A1)} - A3$, where A1, A2 and A3 are refrigerant-specific constants. The refrigerant must be selected in parameter 20-30. Parameters 20-31 through 20-33 allow the values of A1, A2 and A3 to be entered for a refrigerant that is not listed in parameter 20-30.

20-02 Feedback 1 Source Unit

This parameter determines the unit that is used for this Feedback Source, prior to applying the feedback conversion of *par. 20-01, Feedback 1 Conversion*. This unit is not used by the PID Controller. It is used only for display and monitoring purposes.

Option: **Function:**

[70]	mbar	
[71] *	bar	
[72]	Pa	
[73]	kPa	
[74]	m WG	
[170]	psi	
[171]	lb/in ²	
[172]	in WG	
[173]	ft WG	

NOTE

This parameter is only available when using **Pressure to Temperature Feedback Conversion**.

20-12 Reference/Feedback Unit

This parameter determines the unit that is used for the setpoint reference and feedback that the PID Controller will use for controlling the output frequency of the frequency converter.

Option: **Function:**

[60] *	°C	
[160]	°F	

20-21 Setpoint 1		
Range:		Function:
0 ProcessCtrlUnit*	[-999999.999 - 999999.999 ProcessCtrlUnit]	Setpoint 1 is used in Closed Loop Mode to enter a setpoint reference that is used by the frequency converter's PID Controller. See the description of 20-20 Feedback Function. NOTE Setpoint reference entered here is added to any other references that are enabled (see par. group 3-1*).

20-30 Refrigerant

Select the refrigerant used in the compressor application. This parameter must be specified correctly for the pressure to temperature conversion to be accurate. If the refrigerant used is not listed in choices [0] through [6], select *User defined* [7]. Then, use par. 20-31, 20-32 and 20-33 to provide A1, A2 and A3 for the equation below:

$$Temperature = \frac{A2}{(\ln(Pe + 1) - A1)} - A3$$

Option:	Function:
[0] *	R user
[1]	R12
[2]	R22
[3]	R134a
[4]	R502
[5]	R717
[6]	R13
[7]	R13b1
[8]	R23
[9]	R500
[10]	R503
[11]	R114
[12]	R142b
[14]	R32
[15]	R227
[16]	R401A
[17]	R507
[18]	R402A
[19]	R404A
[20]	R407C
[21]	R407A
[22]	R407B
[23]	R410A
[24]	R170
[25]	R290
[26]	R600
[27]	R600a
[28]	R744

20-30 Refrigerant

Select the refrigerant used in the compressor application. This parameter must be specified correctly for the pressure to temperature conversion to be accurate. If the refrigerant used is not listed in choices [0] through [6], select *User defined* [7]. Then, use par. 20-31, 20-32 and 20-33 to provide A1, A2 and A3 for the equation below:

$$Temperature = \frac{A2}{(\ln(Pe + 1) - A1)} - A3$$

Option:	Function:
[29]	R1270
[30]	R417A
[31]	Isceon 29

20-40 Thermostat/Pressostat Function

Set whether the Thermostat/ Pressostat function is active (On) or inactive (Off).

Option:	Function:
[0] *	Off
[1]	On

20-41 Cut-out Value

Range:	Function:
1 bar* [-3000 - par. 20-42]	Select the Cut-out Level where the stop signal is activated and the compressor stops.

20-42 Cut-in Value

Range:	Function:
3 bar* [Par. 20-41 - 3000]	Select the Cut-in Level where the stop signal is de-activated and the compressor starts.

20-93 PID Proportional Gain

Range:	Function:
0.50 N/A*	[0.00 - 10.00 N/A]

If (Error x Gain) jumps with a value equal to what is set in 20-14 Maximum Reference/Feedb. the PID controller will try to change the output speed equal to what is set in 4-13 Motor Speed High Limit [RPM] / 4-14 Motor Speed High Limit [Hz] but in practice of course limited by this setting. The proportional band (error causing output to change from 0-100%) can be calculated by means of the formula:

$$\left(\frac{1}{Proportional\ Gain} \right) \times (Max\ Reference)$$



NOTE

Always set the desired for **20-14 Maximum Reference/Feedb.** before setting the values for the PID controller in par. group 20-9*.

20-94 PID Integral Time		
Range:	Function:	
30.00 s* [0.01 - 10000.00 s]	Over time, the integrator accumulates a contribution to the output from the PID controller as long as there is a deviation between the Reference/Setpoint and feedback signals. The contribution is proportional to the size of the deviation. This ensures that the deviation (error) approaches zero. Quick response on any deviation is obtained when the integral time is set to a low value. Setting it too low, however, may cause the control to become unstable. The value set, is the time needed for the integrator to add the same contribution as the proportional part for a certain deviation. If the value is set to 10,000, the controller will act as a pure proportional controller with a P-band based on the value set in 20-93 PID Proportional Gain. When no deviation is present, the output from the proportional controller will be 0.	

22-40 Minimum Run Time		
Range:	Function:	
10 s* [0 - 600 s]	Set the desired minimum running time for the motor after a start command (digital input or Bus) before entering Sleep Mode.	

22-41 Minimum Sleep Time		
Range:	Function:	
10 s* [0 - 600 s]	Set the desired Minimum Time for staying in Sleep Mode. This will override any wake up conditions.	

22-42 Wake-up Speed [RPM]		
Range:	Function:	
0 RPM* [par. 4-11 - par. 4-13 RPM]	To be used if 0-02 Motor Speed Unit has been set for RPM (parameter not visible if Hz selected). Only to be used if 1-00 Configuration Mode is set for Open Loop and speed reference is applied by an external controller. Set the reference speed at which the Sleep Mode should be cancelled.	

NOTE

Does not work in pack controller mode.

22-43 Wake-up Speed [Hz]		
Range:	Function:	
0 Hz* [par. 4-12 - par. 4-14 Hz]	To be used if 0-02 Motor Speed Unit, has been set for Hz (parameter not visible if RPM selected). Only to be used if 1-00 Configuration Mode, is set for Open Loop and speed reference is applied by an external controller controlling the pressure. Set the reference speed at which the Sleep Mode should be cancelled.	

22-44 Wake-up Ref./FB Difference		
Range:	Function:	
10 %* [0 - 100 %]	Only to be used if 1-00 Configuration Mode is set for Closed Loop and the integrated PI controller is used for controlling the pressure. Set the pressure drop allowed in percentage of set point for the pressure (Pset) before cancelling the Sleep Mode.	

NOTE

If used in application where the integrated PI controller is set for inverse control (e.g. cooling tower applications) in 20-71 PID Performance, the value set in 22-44 Wake-up Ref./FB Difference will automatically be added.

22-75 Short Cycle Protection		
Option:	Function:	
[0] Disabled	Timer set in Interval Between Starts, par. 22-76 is disabled.	
[1] Enabled	Timer set in Interval between Starts, par. 22-76 is enabled.	

22-76 Interval Between Starts		
Range:	Function:	
300 s* [0 - 3600 s]	Sets the time desired as minimum time between two starts. Any normal start command (Start/Jog/Freeze) will be disregarded until the timer has expired.	

22-77 Minimum Run Time		
Range:	Function:	
0 s* [0 - par. 22-76 s]	Sets the time desired as minimum run time after a normal start command (Start/Jog/Freeze). Any normal stop command will be disregarded until the set time has expired. The timer will start counting following a normal start command (Start/Jog/Freeze). The timer will be overridden by a Coast (Inverse) or an External Interlock command.	

25-00 Pack Controller
Option: Function:

		For operation of multiple devices (compressor) systems where capacity is adapted to actual load by means of speed control combined with on/off control of the devices. For simplicity only compressor systems are described.
[0] *	Disabled	The Pack Controller is not active. All built-in relays assigned to compressor motors in the Pack function will be de-energized. If a variable speed compressor is connected to the frequency converter directly (not controlled by a built-in relay), this compressor will be controlled as a single compressor system.
[1]	Enabled	The Pack Controller is active and will stage/destage compressors according to load on the system.

NOTE

This parameter can only be *Enabled* [1], if parameter 28-00 *Short Cycle Protection* is set to *Disabled* [0].

25-06 Number of Compressors
Option: Function:

		The number of compressors connected to the Pack Controller including the variable speed compressor. If the variable speed compressor is connected directly to the frequency converter and the other fixed speed compressors (lag compressors) are controlled by the two built in relays, three compressors can be controlled. If both the variable speed and fixed speed compressors are to be controlled by built-in relays, only two compressors can be connected.
[0] *	2 compressors	If <i>Fixed Lead Compressor</i> , par. 25-05, is set to <i>No</i> [0]: one variable speed compressor and one fixed speed compressor; both controlled by built in relay. If <i>Fixed Lead Compressor</i> , par. 25-05, is set to <i>Yes</i> [1]: one variable speed compressor and one fixed speed compressor controlled by built-in relay
[1]	3 compressors	3 Compressors [1]: One lead compressor, see <i>Fixed Lead Compressor</i> , par. 25-05. Two fixed speed compressors controlled by built-in relays.

25-20 25-20 Neutral Zone [unit]
Range: Function:

4.00*	[0-9999.99]	Set the neutral zone (NZ) to accommodate normal system pressure fluctuations. In pack control systems, to avoid frequent switching of fixed speed compressors, the desired system pressure is typically kept within a zone rather than at a constant level.
-------	-------------	-------------------------------------------------------------------------------------------------------------------------------------------------------------------------------------------------------------------------------------------------------------

25-20 25-20 Neutral Zone [unit]
Range: Function:

		The NZ is programmed in the same unit as selected in par. 20-12 <i>Reference/Feedback Unit</i> . It places a zone above and below the set-point in which staging and destaging will not occur. For example, if the set-point is -20°C and the NZ is set to 4°C, a suction pressure equivalent to a temperature between -24°C and -16°C is tolerated. No staging or destaging will occur within this zone.
--	--	-----------------------------------------------------------------------------------------------------------------------------------------------------------------------------------------------------------------------------------------------------------------------------------------------------------------------------------------------------------------------------------------------------------

25-21 +Zone [unit]
Range: Function:

3.00*	[0-9999.99]	When a large and quick change in the system demand occurs, the system pressure rapidly changes and a quicker staging or destaging of a fixed speed compressor becomes necessary to match the requirement. The +Zone defines the range where the + zone delay is active. Setting the +Zone too close to zero could defeat the purpose with frequent staging at momentary pressure changes. Setting the +Zone too high might lead to an unacceptably high or low pressure in the system while the +Zone Delay timer (par. 25-24) is running. The +Zone value can be optimized with increased familiarity with the system. See ++Zone Delay, par. 25-26. To avoid unintended staging during the commissioning phase and fine tuning of the controller, initially set the +Zone to a large value beyond any expected pressure peak. This implicitly disables the override function for pressure peaks. When the fine tuning is complete, the +Zone should be set to the desired value. An initial value of 3°C is suggested.
-------	-------------	--------------------------------------------------------------------------------------------------------------------------------------------------------------------------------------------------------------------------------------------------------------------------------------------------------------------------------------------------------------------------------------------------------------------------------------------------------------------------------------------------------------------------------------------------------------------------------------------------------------------------------------------------------------------------------------------------------------------------------------------------------------------------------------------------------------------------------------------------------------------------------------------------------------------------------------------------------------------------------------------------------------------------------

25-22 -Zone [unit]
Range: Function:

3.00*	[0-9999.99]	When a large and quick change in the system demand occurs, the system pressure rapidly changes and a quicker staging or destaging of a fixed speed compressor becomes necessary to match the requirement. The -Zone defines the range where the - zone delay is active. Setting the -Zone too close to zero could defeat the purpose with frequent staging at momentary pressure changes. Setting the -Zone too high might lead to an unacceptably high or low pressure in the system while the -Zone Delay timer (par. 25-25) is running. The -Zone value can be optimized with increased
-------	-------------	-----------------------------------------------------------------------------------------------------------------------------------------------------------------------------------------------------------------------------------------------------------------------------------------------------------------------------------------------------------------------------------------------------------------------------------------------------------------------------------------------------------------------------------------------------------------------------------------------

25-22 -Zone [unit]	
Range:	Function:
	<p>familiarity with the system. See --Zone Delay, par. 25-27.</p> <p>To avoid unintended staging during the commissioning phase and fine tuning of the controller, initially set the -Zone to a large value beyond any expected pressure drop. This implicitly disables the override function for pressure drops. When the fine tuning is complete, the -Zone should be set to the desired value. An initial value of 3°C is suggested.</p>

7.1.4 Main Menu Mode

Select the Main Menu mode by pressing the [Main Menu] key. Illustration 6.2 shows the resulting read-out, which appears on the display of the GLCP. Lines 2 through 5 on the display show a list of parameter groups which can be chosen by toggling the up and down buttons.

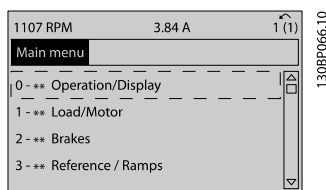

Illustration 7.9 Display example.

Each parameter has a name and number which remain the same regardless of the programming mode. In the Main Menu mode, the parameters are divided into groups. The first digit of the parameter number (from the left) indicates the parameter group number.

All parameters can be changed in the Main Menu. The configuration of the unit (par.1-00) will determine other parameters available for programming. For example, selecting Closed Loop enables additional parameters related to closed loop operation. Option cards added to the unit enable additional parameters associated with the option device.

7.1.5 Parameter Selection

In the Main Menu mode, the parameters are divided into groups. Select a parameter group by means of the navigation keys.

The following parameter groups are accessible:

Group no.	Parameter group:
0	Operation/Display
1	Load/Motor
2	Brakes
3	References/Ramps
4	Limits/Warnings
5	Digital In/Out
6	Analog In/Out
8	Comm. and Options
11	AKD Lon*
13	Smart Logic
14	Special Functions
15	Drive Information
16	Data Readouts
18	Info & Readouts
20	Internal Control
21	Extended PID
22	Application Functions
23	Time-based Functions
25	Pack Controller
26	Analog I/O Option MCB 109**
28	Compressor functions

* Only when MCA 107 AKLon is installed
**Only when MCB 109 is installed

Table 7.3 Parameter groups.

After selecting a parameter group, choose a parameter by means of the navigation keys.

The middle section on the GLCP display shows the parameter number and name as well as the selected parameter value.

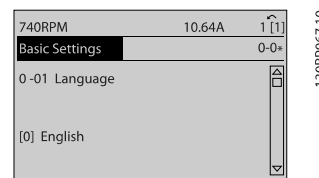

Illustration 7.10 Display example.

7.1.6 Changing Data

1. Press [Quick Menu] or [Main Menu] key.
2. Use [▲] and [▼] keys to find parameter group to edit.
3. Press [OK] key.
4. Use [▲] and [▼] keys to find parameter to edit.
5. Press [OK] key.
6. Use [▲] and [▼] keys to select correct parameter setting. Or, to move to digits within a number, use keys. Cursor indicates digit selected to

change. [▲] key increases the value, [▼] key decreases the value.

- Press [Cancel] key to disregard change, or press [OK] key to accept change and enter new setting.

7.1.7 Changing a text value

If the selected parameter is a text value, change the text value by means of the up/down navigation keys. The up key increases the value, and the down key decreases the value. Place the cursor on the value to be saved and press [OK].

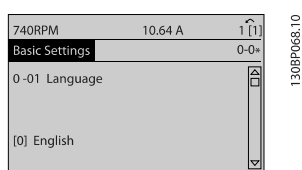

Illustration 7.11 Display example.

7.1.8 Changing a group of numeric data values

If the chosen parameter represents a numeric data value, change the chosen data value by means of the [◀] and [▶] navigation keys as well as the up/down [▲] [▼] navigation keys. Use the [◀] and [▶] navigation keys to move the cursor horizontally.

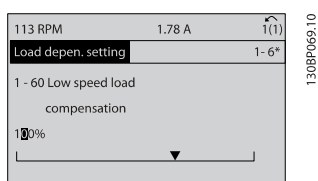

Illustration 7.13 Display example.

Use the up/down navigation keys to change the data value. The up key enlarges the data value, and the down key reduces the data value. Place the cursor on the value to be saved and press [OK].

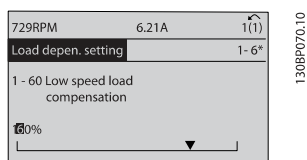

Illustration 7.14 Display example.

7.1.9 Changing of data value, Step-by-Step

Certain parameters can be changed step by step or infinitely variably. This applies to 1-20 Motor Power [kW], 1-22 Motor Voltage and 1-23 Motor Frequency.

The parameters are changed both as a group of numeric data values and as numeric data values infinitely variably.

7.1.10 Read-out and programming of indexed parameters

Parameters are indexed when placed in a rolling stack. 15-30 Alarm Log: Error Code to 15-32 Alarm Log: Time contain a fault log which can be read out. Choose a parameter, press [OK], and use the up/down navigation keys to scroll through the value log.

Use 3-10 Preset Reference as another example: Choose the parameter, press [OK], and use the up/down navigation keys keys to scroll through the indexed values. To change the parameter value, select the indexed value and press [OK]. Change the value by using the up/down keys. Press [OK] to accept the new setting. Press [Cancel] to abort. Press [Back] to leave the parameter.



7.2 Parameter list

Parameters for ADAP-KOOL® Drive AKD102 are grouped into various parameter groups for easy selection of the correct parameters for optimized operation of the frequency converter.

The vast majority of applications can be programmed using the Quick Menu button and selecting the parameters under Quick Setup and Function Setups.

Descriptions and default settings of parameters may be found under the section Parameter Lists at the back of this manual.

0-xx Operation/Display

1-xx Load/Motor

2-xx Brakes

3-xx Reference/Ramps

4-xx Limits/ Warnings

5-xx Digital In/Out

6-xx Analog In/Out

8-xx Comm. and Options

11-xx ADAP-KOOL Lon

13-xx Smart Logic Controller

14-xx Special Functions

15-xx FC Information

16-xx Data Readouts

18-xx Info & Readouts

20-xx FC Closed Loop

21-xx Ext. Closed Loop

22-xx Application Functions

23-xx Time Based Functions

24-xx Application Functions 2

25-xx Pack Controller

26-xx Analog I/O Option MCB 109

28-xx Compressor Functions

7.2.1 0-** Operation and Display

Par. No. #	Parameter description	Default value	4-set-up	Change during operation	Conversion index	Type
0-0* Basic Settings						
0-01	Language	[0] English	1 set-up	TRUE	-	Uint8
0-02	Motor Speed Unit	[1] Hz	2 set-ups	FALSE	-	Uint8
0-03	Regional Settings	[0] International	2 set-ups	FALSE	-	Uint8
0-04	Operating State at Power-up	[0] Resume	All set-ups	TRUE	-	Uint8
0-05	Local Mode Unit	[0] As Motor Speed Unit	2 set-ups	FALSE	-	Uint8
0-1* Set-up Operations						
0-10	Active Set-up	[1] Set-up 1	1 set-up	TRUE	-	Uint8
0-11	Programming Set-up	[9] Active Set-up	All set-ups	TRUE	-	Uint8
0-12	This Set-up Linked to	[0] Not linked	All set-ups	FALSE	-	Uint8
0-13	Readout: Linked Set-ups	0 N/A	All set-ups	FALSE	0	Uint16
0-14	Readout: Prog. Set-ups / Channel	0 N/A	All set-ups	TRUE	0	Int32
0-2* LCP Display						
0-20	Display Line 1.1 Small	ExpressionLimit	All set-ups	TRUE	-	Uint16
0-21	Display Line 1.2 Small	ExpressionLimit	All set-ups	TRUE	-	Uint16
0-22	Display Line 1.3 Small	ExpressionLimit	All set-ups	TRUE	-	Uint16
0-23	Display Line 2 Large	ExpressionLimit	All set-ups	TRUE	-	Uint16
0-24	Display Line 3 Large	ExpressionLimit	All set-ups	TRUE	-	Uint16
0-25	My Personal Menu	ExpressionLimit	1 set-up	TRUE	0	Uint16
0-3* LCP Custom Readout						
0-30	Custom Readout Unit	[1] %	All set-ups	TRUE	-	Uint8
0-31	Custom Readout Min Value	ExpressionLimit	All set-ups	TRUE	-2	Int32
0-32	Custom Readout Max Value	100.00 CustomReadoutUnit	All set-ups	TRUE	-2	Int32
0-37	Display Text 1	0 N/A	1 set-up	TRUE	0	VisStr[25]
0-38	Display Text 2	0 N/A	1 set-up	TRUE	0	VisStr[25]
0-39	Display Text 3	0 N/A	1 set-up	TRUE	0	VisStr[25]
0-4* LCP Keypad						
0-40	[Hand on] Key on LCP	[1] Enabled	All set-ups	TRUE	-	Uint8
0-41	[Off] Key on LCP	[1] Enabled	All set-ups	TRUE	-	Uint8
0-42	[Auto on] Key on LCP	[1] Enabled	All set-ups	TRUE	-	Uint8
0-43	[Reset] Key on LCP	[1] Enabled	All set-ups	TRUE	-	Uint8
0-44	[Off/Reset] Key on LCP	[1] Enabled	All set-ups	TRUE	-	Uint8
0-45	[Drive Bypass] Key on LCP	[1] Enabled	All set-ups	TRUE	-	Uint8
0-5* Copy/Save						
0-50	LCP Copy	[0] No copy	All set-ups	FALSE	-	Uint8
0-51	Set-up Copy	[0] No copy	All set-ups	FALSE	-	Uint8

Par. No. #	Parameter description	Default value	4-set-up	Change during operation	Conversion index	Type
0-6* Password						
0-60	Main Menu Password	100 N/A	1 set-up	TRUE	0	Uint16
0-61	Access to Main Menu w/o Password	[0] Full access	1 set-up	TRUE	-	Uint8
0-65	Personal Menu Password	200 N/A	1 set-up	TRUE	0	Uint16
0-66	Access to Personal Menu w/o Password	[0] Full access	1 set-up	TRUE	-	Uint8
0-7* Clock Settings						
0-70	Set Date and Time	ExpressionLimit	All set-ups	TRUE	0	TimeOfDay
0-71	Date Format	null	1 set-up	TRUE	-	Uint8
0-72	Time Format	null	1 set-up	TRUE	-	Uint8
0-74	DST/Summertime	[0] Off	1 set-up	TRUE	-	Uint8
0-76	DST/Summertime Start	ExpressionLimit	1 set-up	TRUE	0	TimeOfDay
0-77	DST/Summertime End	ExpressionLimit	1 set-up	TRUE	0	TimeOfDay
0-79	Clock Fault	[0] Disabled	1 set-up	TRUE	-	Uint8
0-81	Working Days	null	1 set-up	TRUE	-	Uint8
0-82	Additional Working Days	ExpressionLimit	1 set-up	TRUE	0	TimeOfDay
0-83	Additional Non-Working Days	ExpressionLimit	1 set-up	TRUE	0	TimeOfDay
0-89	Date and Time Readout	0 N/A	All set-ups	TRUE	0	VisStr[25]

7.2.2 1-** Load / Motor

Par. No. #	Parameter description	Default value	4-set-up	Change during operation	Conversion index	Type
1-0* General Settings						
1-00	Configuration Mode	null	All set-ups	TRUE	-	Uint8
1-03	Torque Characteristics	[0] Compressor CT	All set-ups	TRUE	-	Uint8
1-2* Motor Data						
1-20	Motor Power [kW]	ExpressionLimit	All set-ups	FALSE	1	Uint32
1-21	Motor Power [HP]	ExpressionLimit	All set-ups	FALSE	-2	Uint32
1-22	Motor Voltage	ExpressionLimit	All set-ups	FALSE	0	Uint16
1-23	Motor Frequency	ExpressionLimit	All set-ups	FALSE	0	Uint16
1-24	Motor Current	ExpressionLimit	All set-ups	FALSE	-2	Uint32
1-25	Motor Nominal Speed	ExpressionLimit	All set-ups	FALSE	67	Uint16
1-28	Motor Rotation Check	[0] Off	All set-ups	FALSE	-	Uint8
1-29	Automatic Motor Adaptation (AMA)	[0] Off	All set-ups	FALSE	-	Uint8
1-3* Adv. Motor Data						
1-30	Stator Resistance (Rs)	ExpressionLimit	All set-ups	FALSE	-4	Uint32
1-31	Rotor Resistance (Rr)	ExpressionLimit	All set-ups	FALSE	-4	Uint32
1-35	Main Reactance (Xh)	ExpressionLimit	All set-ups	FALSE	-4	Uint32
1-36	Iron Loss Resistance (Rfe)	ExpressionLimit	All set-ups	FALSE	-3	Uint32
1-39	Motor Poles	ExpressionLimit	All set-ups	FALSE	0	Uint8
1-5* Load Indep. Setting						
1-50	Motor Magnetisation at Zero Speed	100 %	All set-ups	TRUE	0	Uint16
1-51	Min Speed Normal Magnetising [RPM]	ExpressionLimit	All set-ups	TRUE	67	Uint16
1-52	Min Speed Normal Magnetising [Hz]	ExpressionLimit	All set-ups	TRUE	-1	Uint16
1-6* Load Depen. Setting						
1-60	Low Speed Load Compensation	100 %	All set-ups	TRUE	0	Int16
1-61	High Speed Load Compensation	100 %	All set-ups	TRUE	0	Int16
1-62	Slip Compensation	0 %	All set-ups	TRUE	0	Int16
1-63	Slip Compensation Time Constant	0.10 s	All set-ups	TRUE	-2	Uint16
1-64	Resonance Dampening	100 %	All set-ups	TRUE	0	Uint16
1-65	Resonance Dampening Time Constant	5 ms	All set-ups	TRUE	-3	Uint8
1-7* Start Adjustments						
1-71	Start Delay	00.0 s	All set-ups	TRUE	-1	Uint16
1-72	Start Function	[2] Coast	All set-ups	TRUE	-	Uint8
1-73	Flying Start	[0] Disabled	All set-ups	FALSE	-	Uint8
1-74	Start Speed [RPM]	ExpressionLimit	All set-ups	TRUE	67	Uint16
1-75	Start Speed [Hz]	ExpressionLimit	All set-ups	TRUE	-1	Uint16
1-76	Start Current	0.00 A	All set-ups	TRUE	-2	Uint32
1-77	Compressor Start Max Speed [RPM]	ExpressionLimit	All set-ups	TRUE	67	Uint16
1-78	Compressor Start Max Speed [Hz]	ExpressionLimit	All set-ups	TRUE	-1	Uint16
1-79	Compressor Start Max Time to Trip	5.0 s	All set-ups	TRUE	-1	Uint8
1-8* Stop Adjustments						
1-80	Function at Stop	[0] Coast	All set-ups	TRUE	-	Uint8
1-81	Min Speed for Function at Stop [RPM]	ExpressionLimit	All set-ups	TRUE	67	Uint16
1-82	Min Speed for Function at Stop [Hz]	ExpressionLimit	All set-ups	TRUE	-1	Uint16
1-86	Compressor Min. Speed for Trip [RPM]	ExpressionLimit	All set-ups	TRUE	67	Uint16
1-87	Compressor Min. Speed for Trip [Hz]	ExpressionLimit	All set-ups	TRUE	-1	Uint16
1-9* Motor Temperature						
1-90	Motor Thermal Protection	[0] No protection	All set-ups	TRUE	-	Uint8
1-91	Motor External Fan	[0] No	All set-ups	TRUE	-	Uint16
1-93	Thermistor Source	[0] None	All set-ups	TRUE	-	Uint8

7.2.3 2-** Brakes

Par. No. #	Parameter description	Default value	4-set-up	Change during operation	Conversion index	Type
2-0* DC-Brake						
2-00	DC Hold/Preheat Current	50 %	All set-ups	TRUE	0	Uint8
2-01	DC Brake Current	50 %	All set-ups	TRUE	0	Uint16
2-02	DC Braking Time	10.0 s	All set-ups	TRUE	-1	Uint16
2-03	DC Brake Cut In Speed [RPM]	ExpressionLimit	All set-ups	TRUE	67	Uint16
2-04	DC Brake Cut In Speed [Hz]	ExpressionLimit	All set-ups	TRUE	-1	Uint16
2-1* Brake Energy Funct.						
Brake Function						
2-10	Brake Resistor (ohm)	[0] Off	All set-ups	TRUE	-	Uint8
2-11	Brake Resistor Limit (ohm)	ExpressionLimit	All set-ups	TRUE	0	Uint16
2-12	Brake Power Limit (kW)	ExpressionLimit	All set-ups	TRUE	0	Uint32
2-13	Brake Power Monitoring	[0] Off	All set-ups	TRUE	-	Uint8
2-15	Brake Check	[0] Off	All set-ups	TRUE	-	Uint8
2-16	AC brake Max. Current	100.0 %	All set-ups	TRUE	-1	Uint32
2-17	Over-voltage Control	[2] Enabled	All set-ups	TRUE	-	Uint8

7.2.4 3-** Reference / Ramps

Par. No. #	Parameter description	Default value	4-set-up	Change during operation	Conversion index	Type
3-0* Reference Limits						
3-02	Minimum Reference	ExpressionLimit	All set-ups	TRUE	-3	Int32
3-03	Maximum Reference	ExpressionLimit	All set-ups	TRUE	-3	Int32
3-04	Reference Function	[0] Sum	All set-ups	TRUE	-	UInt8
3-1* References						
3-10	Preset Reference	0.00 %	All set-ups	TRUE	-2	Int16
3-11	Jog Speed [Hz]	ExpressionLimit	All set-ups	TRUE	-1	UInt16
3-13	Reference Site	[0] Linked to Hand / Auto	All set-ups	TRUE	-	UInt8
3-14	Preset Relative Reference	0.00 %	All set-ups	TRUE	-2	Int32
3-15	Reference 1 Source	[1] Analog input 53	All set-ups	TRUE	-	UInt8
3-16	Reference 2 Source	[20] Digital pot:meter	All set-ups	TRUE	-	UInt8
3-17	Reference 3 Source	[0] No function	All set-ups	TRUE	-	UInt8
3-19	Jog Speed [RPM]	ExpressionLimit	All set-ups	TRUE	67	UInt16
3-4* Ramp 1						
3-41	Ramp 1 Ramp Up Time	ExpressionLimit	All set-ups	TRUE	-2	UInt32
3-42	Ramp 1 Ramp Down Time	ExpressionLimit	All set-ups	TRUE	-2	UInt32
3-5* Ramp 2						
3-51	Ramp 2 Ramp Up Time	ExpressionLimit	All set-ups	TRUE	-2	UInt32
3-52	Ramp 2 Ramp Down Time	ExpressionLimit	All set-ups	TRUE	-2	UInt32
3-8* Other Ramps						
3-80	Jog Ramp Time	ExpressionLimit	All set-ups	TRUE	-2	UInt32
3-81	Quick Stop Ramp Time	ExpressionLimit	2 set-ups	TRUE	-2	UInt32
3-82	Starting Ramp Up Time	ExpressionLimit	2 set-ups	TRUE	-2	UInt32
3-9* Digital Pot:Meter						
3-90	Step Size	0.10 %	All set-ups	TRUE	-2	UInt16
3-91	Ramp Time	1.00 s	All set-ups	TRUE	-2	UInt32
3-92	Power Restore	[0] Off	All set-ups	TRUE	-	UInt8
3-93	Maximum Limit	100 %	All set-ups	TRUE	0	Int16
3-94	Minimum Limit	0 %	All set-ups	TRUE	0	Int16
3-95	Ramp Delay	1.000 N/A	All set-ups	TRUE	-3	TimD

7.2.5 4-** Limits / Warnings

7

Par. No. #	Parameter description	Default value	4-set-up	Change during operation	Conversion index	Type
4-1* Motor Limits						
4-10	Motor Speed Direction	[0] Clockwise	All set-ups	FALSE	-	Uint8
4-11	Motor Speed Low Limit [RPM]	ExpressionLimit	All set-ups	TRUE	67	Uint16
4-12	Motor Speed Low Limit [Hz]	ExpressionLimit	All set-ups	TRUE	-1	Uint16
4-13	Motor Speed High Limit [RPM]	ExpressionLimit	All set-ups	TRUE	67	Uint16
4-14	Motor Speed High Limit [Hz]	ExpressionLimit	All set-ups	TRUE	-1	Uint16
4-16	Torque Limit Motor Mode	110.0 %	All set-ups	TRUE	-1	Uint16
4-17	Torque Limit Generator Mode	100.0 %	All set-ups	TRUE	-1	Uint16
4-18	Current Limit	ExpressionLimit	All set-ups	TRUE	-1	Uint32
4-19	Max Output Frequency	ExpressionLimit	All set-ups	FALSE	-1	Uint16
4-5* Adj. Warnings						
4-50	Warning Current Low	0.00 A	All set-ups	TRUE	-2	Uint32
4-51	Warning Current High	ImaxVLT (P1637)	All set-ups	TRUE	-2	Uint32
4-52	Warning Speed Low	0 RPM	All set-ups	TRUE	67	Uint16
4-53	Warning Speed High	outputSpeedHighLimit (P413)	All set-ups	TRUE	67	Uint16
4-54	Warning Reference Low	-999999.000 N/A	All set-ups	TRUE	-3	Int32
4-55	Warning Reference High	999999.000 N/A	All set-ups	TRUE	-3	Int32
4-56	Warning Feedback Low	-999999.000 ReferenceFeedbackUnit	All set-ups	TRUE	-3	Int32
4-57	Warning Feedback High	999999.000 ReferenceFeedbackUnit	All set-ups	TRUE	-3	Int32
4-58	Missing Motor Phase Function	[1] On	All set-ups	TRUE	-	Uint8
4-6* Speed Bypass						
4-60	Bypass Speed From [RPM]	ExpressionLimit	All set-ups	TRUE	67	Uint16
4-61	Bypass Speed From [Hz]	ExpressionLimit	All set-ups	TRUE	-1	Uint16
4-62	Bypass Speed To [RPM]	ExpressionLimit	All set-ups	TRUE	67	Uint16
4-63	Bypass Speed To [Hz]	ExpressionLimit	All set-ups	TRUE	-1	Uint16
4-64	Semi-Auto Bypass Set-up	[0] Off	All set-ups	FALSE	-	Uint8

7.2.6 5-** Digital In / Out

Par. No. #	Parameter description	Default value	4-set-up	Change during operation	Conversion index	Type
5-0* Digital I/O mode						
5-00	Digital I/O Mode	[0] PNP - Active at 24V	All set-ups	FALSE	-	Uint8
5-01	Terminal 27 Mode	[0] Input	All set-ups	TRUE	-	Uint8
5-02	Terminal 29 Mode	[0] Input	All set-ups	TRUE	-	Uint8
5-1* Digital Inputs						
5-10	Terminal 18 Digital Input	[8] Start	All set-ups	TRUE	-	Uint8
5-11	Terminal 19 Digital Input	[10] Reversing	All set-ups	TRUE	-	Uint8
5-12	Terminal 27 Digital Input	null	All set-ups	TRUE	-	Uint8
5-13	Terminal 29 Digital Input	[0] No operation	All set-ups	TRUE	-	Uint8
5-14	Terminal 32 Digital Input	[39] Day/Night Control	All set-ups	TRUE	-	Uint8
5-15	Terminal 33 Digital Input	[0] No operation	All set-ups	TRUE	-	Uint8
5-16	Terminal X30/2 Digital Input	[0] No operation	All set-ups	TRUE	-	Uint8
5-17	Terminal X30/3 Digital Input	[0] No operation	All set-ups	TRUE	-	Uint8
5-18	Terminal X30/4 Digital Input	[0] No operation	All set-ups	TRUE	-	Uint8
5-3* Digital Outputs						
5-30	Terminal 27 Digital Output	[0] No operation	All set-ups	TRUE	-	Uint8
5-31	Terminal 29 Digital Output	[0] No operation	All set-ups	TRUE	-	Uint8
5-32	Term X30/6 Digi Out (MCB 101)	[0] No operation	All set-ups	TRUE	-	Uint8
5-33	Term X30/7 Digi Out (MCB 101)	[0] No operation	All set-ups	TRUE	-	Uint8
5-4* Relays						
5-40	Function Relay	null	All set-ups	TRUE	-	Uint8
5-41	On Delay, Relay	0.01 s	All set-ups	TRUE	-2	Uint16
5-42	Off Delay, Relay	0.01 s	All set-ups	TRUE	-2	Uint16
5-5* Pulse Input						
5-50	Term. 29 Low Frequency	100 Hz	All set-ups	TRUE	0	Uint32
5-51	Term. 29 High Frequency	100 Hz	All set-ups	TRUE	0	Uint32
5-52	Term. 29 Low Ref./Feedb. Value	0.000 N/A	All set-ups	TRUE	-3	Int32
5-53	Term. 29 High Ref./Feedb. Value	100.000 N/A	All set-ups	TRUE	-3	Int32
5-54	Pulse Filter Time Constant #29	100 ms	All set-ups	FALSE	-3	Uint16
5-55	Term. 33 Low Frequency	100 Hz	All set-ups	TRUE	0	Uint32
5-56	Term. 33 High Frequency	100 Hz	All set-ups	TRUE	0	Uint32
5-57	Term. 33 Low Ref./Feedb. Value	0.000 N/A	All set-ups	TRUE	-3	Int32
5-58	Term. 33 High Ref./Feedb. Value	100.000 N/A	All set-ups	TRUE	-3	Int32
5-59	Pulse Filter Time Constant #33	100 ms	All set-ups	FALSE	-3	Uint16

Par. No. #	Parameter description	Default value	4-set-up	Change during operation	Conversion index	Type
5-6* Pulse Output						
5-60	Terminal 27 Pulse Output Variable	[0] No operation	All set-ups	TRUE	-	Uint8
5-62	Pulse Output Max Freq #27	5000 Hz	All set-ups	TRUE	0	Uint32
5-63	Terminal 29 Pulse Output Variable	[0] No operation	All set-ups	TRUE	-	Uint8
5-65	Pulse Output Max Freq #29	5000 Hz	All set-ups	TRUE	0	Uint32
5-66	Terminal X30/6 Pulse Output Variable	[0] No operation	All set-ups	TRUE	-	Uint8
5-68	Pulse Output Max Freq #X30/6	5000 Hz	All set-ups	TRUE	0	Uint32
5-9* Bus Controlled						
5-90	Digital & Relay Bus Control	0 N/A	All set-ups	TRUE	0	Uint32
5-93	Pulse Out #27 Bus Control	0.00 %	All set-ups	TRUE	-2	N2
5-94	Pulse Out #27 Timeout Preset	0.00 %	1 set-up	TRUE	-2	Uint16
5-95	Pulse Out #29 Bus Control	0.00 %	All set-ups	TRUE	-2	N2
5-96	Pulse Out #29 Timeout Preset	0.00 %	1 set-up	TRUE	-2	Uint16
5-97	Pulse Out #X30/6 Bus Control	0.00 %	All set-ups	TRUE	-2	N2
5-98	Pulse Out #X30/6 Timeout Preset	0.00 %	1 set-up	TRUE	-2	Uint16

7.2.7 6-** Analog In / Out

Par. No. #	Parameter description	Default value	4-set-up	Change during operation	Conversion index	Type
6-0* Analog I/O Mode						
6-00	Live Zero Timeout Time	10 s	All set-ups	TRUE	0	Uint8
6-01	Live Zero Timeout Function	[0] Off	All set-ups	TRUE	-	Uint8
6-02	Fire Mode Live Zero Timeout Function	[0] Off	All set-ups	TRUE	-	Uint8
6-1* Analog Input 53						
6-10	Terminal 53 Low Voltage	0.07 V	All set-ups	TRUE	-2	Int16
6-11	Terminal 53 High Voltage	10.00 V	All set-ups	TRUE	-2	Int16
6-12	Terminal 53 Low Current	4.00 mA	All set-ups	TRUE	-5	Int16
6-13	Terminal 53 High Current	20.00 mA	All set-ups	TRUE	-5	Int16
6-14	Terminal 53 Low Ref./Feedb. Value	0.000 N/A	All set-ups	TRUE	-3	Int32
6-15	Terminal 53 High Ref./Feedb. Value	ExpressionLimit	All set-ups	TRUE	-3	Int32
6-16	Terminal 53 Filter Time Constant	0.001 s	All set-ups	TRUE	-3	Uuint16
6-17	Terminal 53 Live Zero	[1] Enabled	All set-ups	TRUE	-	Uuint8
6-2* Analog Input 54						
6-20	Terminal 54 Low Voltage	0.07 V	All set-ups	TRUE	-2	Int16
6-21	Terminal 54 High Voltage	10.00 V	All set-ups	TRUE	-2	Int16
6-22	Terminal 54 Low Current	4.00 mA	All set-ups	TRUE	-5	Int16
6-23	Terminal 54 High Current	20.00 mA	All set-ups	TRUE	-5	Int16
6-24	Terminal 54 Low Ref./Feedb. Value	-1.000 N/A	All set-ups	TRUE	-3	Int32
6-25	Terminal 54 High Ref./Feedb. Value	ExpressionLimit	All set-ups	TRUE	-3	Int32
6-26	Terminal 54 Filter Time Constant	0.001 s	All set-ups	TRUE	-3	Uuint16
6-27	Terminal 54 Live Zero	[1] Enabled	All set-ups	TRUE	-	Uuint8
6-3* Analog Input X30/11						
6-30	Terminal X30/11 Low Voltage	0.07 V	All set-ups	TRUE	-2	Int16
6-31	Terminal X30/11 High Voltage	10.00 V	All set-ups	TRUE	-2	Int16
6-34	Term. X30/11 Low Ref./Feedb. Value	0.000 N/A	All set-ups	TRUE	-3	Int32
6-35	Term. X30/11 High Ref./Feedb. Value	100.000 N/A	All set-ups	TRUE	-3	Int32
6-36	Term. X30/11 Filter Time Constant	0.001 s	All set-ups	TRUE	-3	Uuint16
6-37	Term. X30/11 Live Zero	[1] Enabled	All set-ups	TRUE	-	Uuint8
6-4* Analog Input X30/12						
6-40	Terminal X30/12 Low Voltage	0.07 V	All set-ups	TRUE	-2	Int16
6-41	Terminal X30/12 High Voltage	10.00 V	All set-ups	TRUE	-2	Int16
6-44	Term. X30/12 Low Ref./Feedb. Value	0.000 N/A	All set-ups	TRUE	-3	Int32
6-45	Term. X30/12 High Ref./Feedb. Value	100.000 N/A	All set-ups	TRUE	-3	Int32
6-46	Term. X30/12 Filter Time Constant	0.001 s	All set-ups	TRUE	-3	Uuint16
6-47	Term. X30/12 Live Zero	[1] Enabled	All set-ups	TRUE	-	Uuint8

Par. No. #	Parameter description	Default value	4-set-up	Change during operation	Conversion index	Type
6-5* Analog Output 42						
6-50	Terminal 42 Output	[100] Output frequency	All set-ups	TRUE	-	Uint8
6-51	Terminal 42 Output Min Scale	0.00 %	All set-ups	TRUE	-2	Int16
6-52	Terminal 42 Output Max Scale	100.00 %	All set-ups	TRUE	-2	Int16
6-53	Terminal 42 Output Bus Control	0.00 %	All set-ups	TRUE	-2	N2
6-54	Terminal 42 Output Timeout Preset	0.00 %	1 set-up	TRUE	-2	Uint16
6-6* Analog Output X30/8						
6-60	Terminal X30/8 Output	[0] No operation	All set-ups	TRUE	-	Uint8
6-61	Terminal X30/8 Min. Scale	0.00 %	All set-ups	TRUE	-2	Int16
6-62	Terminal X30/8 Max. Scale	100.00 %	All set-ups	TRUE	-2	Int16
6-63	Terminal X30/8 Output Bus Control	0.00 %	All set-ups	TRUE	-2	N2
6-64	Terminal X30/8 Output Timeout Preset	0.00 %	1 set-up	TRUE	-2	Uint16

7.2.8 8-** Communication and Options

Par. No. #	Parameter description	Default value	4-set-up	Change during operation	Conversion index	Type
8-0* General Settings						
8-01	Control Site	null	All set-ups	TRUE	-	Uint8
8-02	Control Source	null	All set-ups	TRUE	-	Uint8
8-03	Control Timeout Time	ExpressionLimit	1 set-up	TRUE	-1	Uint32
8-04	Control Timeout Function	[0] Off	1 set-up	TRUE	-	Uint8
8-05	End-of-Timeout Function	[1] Resume set-up	1 set-up	TRUE	-	Uint8
8-06	Reset Control Timeout	[0] Do not reset	All set-ups	TRUE	-	Uint8
8-07	Diagnosis Trigger	[0] Disable	2 set-ups	TRUE	-	Uint8
8-1* Control Settings						
8-10	Control Profile	[0] FC profile	All set-ups	TRUE	-	Uint8
8-13	Configurable Status Word STW	[1] Profile Default	All set-ups	TRUE	-	Uint8
8-3* FC Port Settings						
8-30	Protocol	[0] FC	1 set-up	TRUE	-	Uint8
8-31	Address	ExpressionLimit	1 set-up	TRUE	0	Uint8
8-32	Baud Rate	null	1 set-up	TRUE	-	Uint8
8-33	Parity / Stop Bits	null	1 set-up	TRUE	-	Uint8
8-35	Minimum Response Delay	ExpressionLimit	1 set-up	TRUE	-3	Uint16
8-36	Maximum Response Delay	ExpressionLimit	1 set-up	TRUE	-3	Uint16
8-37	Maximum Inter-Char Delay	ExpressionLimit	1 set-up	TRUE	-5	Uint16
8-4* Adv. Protocol Set.						
8-40	Telegram Selection	[1] Standard telegram 1	2 set-ups	TRUE	-	Uint8
8-45	BTM Transaction Command	[0] Off	All set-ups	FALSE	-	Uint8
8-46	BTM Transaction Status	[0] Off	All set-ups	TRUE	-	Uint8
8-47	BTM Timeout	60 s	1 set-up	FALSE	0	Uint16
8-5* Digital/Bus						
8-50	Coasting Select	[3] Logic OR	All set-ups	TRUE	-	Uint8
8-52	DC Brake Select	[3] Logic OR	All set-ups	TRUE	-	Uint8
8-53	Start Select	[3] Logic OR	All set-ups	TRUE	-	Uint8
8-54	Reversing Select	null	All set-ups	TRUE	-	Uint8
8-55	Set-up Select	[3] Logic OR	All set-ups	TRUE	-	Uint8
8-56	Preset Reference Select	[3] Logic OR	All set-ups	TRUE	-	Uint8
8-7* BACnet						
8-70	BACnet Device Instance	1 N/A	1 set-up	TRUE	0	Uint32
8-72	MS/TP Max Masters	127 N/A	1 set-up	TRUE	0	Uint8
8-73	MS/TP Max Info Frames	1 N/A	1 set-up	TRUE	0	Uint16
8-74	"I-Am" Service	[0] Send at power-up	1 set-up	TRUE	-	Uint8
8-75	Initialisation Password	ExpressionLimit	1 set-up	TRUE	0	VisStr[20]
8-8* FC Port Diagnostics						
8-80	Bus Message Count	0 N/A	All set-ups	TRUE	0	Uint32
8-81	Bus Error Count	0 N/A	All set-ups	TRUE	0	Uint32
8-82	Slave Message Count	0 N/A	All set-ups	TRUE	0	Uint32
8-83	Slave Error Count	0 N/A	All set-ups	TRUE	0	Uint32
8-9* Bus Jog / Feedback						
8-90	Bus Jog 1 Speed	100 RPM	All set-ups	TRUE	67	Uint16
8-91	Bus Jog 2 Speed	200 RPM	All set-ups	TRUE	67	Uint16
8-94	Bus Feedback 1	0 N/A	1 set-up	TRUE	0	N2
8-95	Bus Feedback 2	0 N/A	1 set-up	TRUE	0	N2
8-96	Bus Feedback 3	0 N/A	1 set-up	TRUE	0	N2

7.2.9 11-** ADAP-KOOL LON

7

Par. No. #	Parameter description	Default value	4-set-up	Change during operation	Conversion index	Type
11-2* LON Param. Access						
11-21	Store Data Values	[0] Off	All set-ups	TRUE	-	UInt8
11-9* AK LonWorks						
11-90	AK Network Address	0 N/A	1 set-up	TRUE	0	UInt16
11-91	AK Service Pin	[0] Off	1 set-up	TRUE	-	UInt8
11-98	Alarm Text	0 N/A	All set-ups	FALSE	0	VisStr[32]
11-99	Alarm Status	0 N/A	All set-ups	FALSE	0	UInt8

7.2.10 13-** Smart Logic Controller

Par. No. #	Parameter description	Default value	4-set-up	Change during operation	Conversion index	Type
13-0* SLC Settings						
13-00	SL Controller Mode	null	2 set-ups	TRUE	-	Uint8
13-01	Start Event	null	2 set-ups	TRUE	-	Uint8
13-02	Stop Event	null	2 set-ups	TRUE	-	Uint8
13-03	Reset SLC	[0] Do not reset SLC	All set-ups	TRUE	-	Uint8
13-1* Comparators						
13-10	Comparator Operand	null	2 set-ups	TRUE	-	Uint8
13-11	Comparator Operator	null	2 set-ups	TRUE	-	Uint8
13-12	Comparator Value	ExpressionLimit	2 set-ups	TRUE	-3	Int32
13-2* Timers						
13-20	SL Controller Timer	ExpressionLimit	1 set-up	TRUE	-3	TimD
13-4* Logic Rules						
13-40	Logic Rule Boolean 1	null	2 set-ups	TRUE	-	Uint8
13-41	Logic Rule Operator 1	null	2 set-ups	TRUE	-	Uint8
13-42	Logic Rule Boolean 2	null	2 set-ups	TRUE	-	Uint8
13-43	Logic Rule Operator 2	null	2 set-ups	TRUE	-	Uint8
13-44	Logic Rule Boolean 3	null	2 set-ups	TRUE	-	Uint8
13-5* States						
13-51	SL Controller Event	null	2 set-ups	TRUE	-	Uint8
13-52	SL Controller Action	null	2 set-ups	TRUE	-	Uint8

7.2.11 14-** Special Functions

Par. No. #	Parameter description	Default value	4-set-up	Change during operation	Conversion index	Type
14-0* Inverter Switching						
14-00	Switching Pattern	[0] 60 AVM	All set-ups	TRUE	-	Uint8
14-01	Switching Frequency	null	All set-ups	TRUE	-	Uint8
14-03	Overmodulation	[1] On	All set-ups	FALSE	-	Uint8
14-04	PWM Random	[0] Off	All set-ups	TRUE	-	Uint8
14-1* Mains On/Off						
14-12	Function at Mains Imbalance	[0] Trip	All set-ups	TRUE	-	Uint8
14-2* Reset Functions						
14-20	Reset Mode	[0] Manual reset	All set-ups	TRUE	-	Uint8
14-21	Automatic Restart Time	10 s	All set-ups	TRUE	0	Uint16
14-22	Operation Mode	[0] Normal operation	All set-ups	TRUE	-	Uint8
14-23	Typecode Setting	null	2 set-ups	FALSE	-	Uint8
14-25	Trip Delay at Torque Limit	60 s	All set-ups	TRUE	0	Uint8
14-26	Trip Delay at Inverter Fault	ExpressionLimit	All set-ups	TRUE	0	Uint8
14-28	Production Settings	[0] No action	All set-ups	TRUE	-	Uint8
14-29	Service Code	0 N/A	All set-ups	TRUE	0	Int32
14-3* Current Limit Ctrl.						
14-30	Current Lim Ctrl, Proportional Gain	100 %	All set-ups	FALSE	0	Uint16
14-31	Current Lim Ctrl, Integration Time	0.020 s	All set-ups	FALSE	-3	Uint16
14-4* Energy Optimising						
14-40	VT Level	66 %	All set-ups	FALSE	0	Uint8
14-41	AEO Minimum Magnetisation	40 %	All set-ups	TRUE	0	Uint8
14-42	Minimum AEO Frequency	10 Hz	All set-ups	TRUE	0	Uint8
14-43	Motor Cosphi	ExpressionLimit	All set-ups	TRUE	-2	Uint16
14-5* Environment						
14-50	RFI Filter	[1] On	1 set-up	FALSE	-	Uint8
14-52	Fan Control	[0] Auto	All set-ups	TRUE	-	Uint8
14-53	Fan Monitor	[1] Warning	All set-ups	TRUE	-	Uint8
14-55	Output Filter	[0] No Filter	1 set-up	FALSE	-	Uint8
14-6* Auto Derate						
14-60	Function at Over Temperature	[0] Trip	All set-ups	TRUE	-	Uint8
14-61	Function at Inverter Overload	[0] Trip	All set-ups	TRUE	-	Uint8
14-62	Inv. Overload Derate Current	95 %	All set-ups	TRUE	0	Uint16

7.2.12 15-** FC Information

Par. No. #	Parameter description	Default value	4-set-up	Change during operation	Conversion index	Type
15-0* Operating Data						
15-00	Operating Hours	0 h	All set-ups	FALSE	74	Uint32
15-01	Running Hours	0 h	All set-ups	FALSE	74	Uint32
15-02	kWh Counter	0 kWh	All set-ups	FALSE	75	Uint32
15-03	Power Up's	0 N/A	All set-ups	FALSE	0	Uint32
15-04	Over Temp's	0 N/A	All set-ups	FALSE	0	Uint16
15-05	Over Volt's	0 N/A	All set-ups	FALSE	0	Uint16
15-06	Reset kWh Counter	[0] Do not reset	All set-ups	TRUE	-	Uint8
15-07	Reset Running Hours Counter	[0] Do not reset	All set-ups	TRUE	-	Uint8
15-08	Number of Starts	0 N/A	All set-ups	FALSE	0	Uint32
15-1* Data Log Settings						
15-10	Logging Source	0	2 set-ups	TRUE	-	Uint16
15-11	Logging Interval	ExpressionLimit	2 set-ups	TRUE	-3	TimD
15-12	Trigger Event	[0] False	1 set-up	TRUE	-	Uint8
15-13	Logging Mode	[0] Log always	2 set-ups	TRUE	-	Uint8
15-14	Samples Before Trigger	50 N/A	2 set-ups	TRUE	0	Uint8
15-2* Historic Log						
15-20	Historic Log: Event	0 N/A	All set-ups	FALSE	0	Uint8
15-21	Historic Log: Value	0 N/A	All set-ups	FALSE	0	Uint32
15-22	Historic Log: Time	0 ms	All set-ups	FALSE	-3	Uint32
15-23	Historic Log: Date and Time	ExpressionLimit	All set-ups	FALSE	0	TimeOfDay
15-3* Alarm Log						
15-30	Alarm Log: Error Code	0 N/A	All set-ups	FALSE	0	Uint8
15-31	Alarm Log: Value	0 N/A	All set-ups	FALSE	0	Int16
15-32	Alarm Log: Time	0 s	All set-ups	FALSE	0	Uint32
15-33	Alarm Log: Date and Time	ExpressionLimit	All set-ups	FALSE	0	TimeOfDay
15-34	Alarm Log: Status	0 N/A	All set-ups	FALSE	0	Uint8
15-35	Alarm Log: Alarm Text	0 N/A	All set-ups	FALSE	0	VisStr[32]
15-4* Drive Identification						
15-40	FC Type	0 N/A	All set-ups	FALSE	0	VisStr[6]
15-41	Power Section	0 N/A	All set-ups	FALSE	0	VisStr[20]
15-42	Voltage	0 N/A	All set-ups	FALSE	0	VisStr[20]
15-43	Software Version	0 N/A	All set-ups	FALSE	0	VisStr[5]
15-44	Ordered Typecode String	0 N/A	All set-ups	FALSE	0	VisStr[40]
15-45	Actual Typecode String	0 N/A	All set-ups	FALSE	0	VisStr[40]
15-46	Frequency Converter Ordering No	0 N/A	All set-ups	FALSE	0	VisStr[8]
15-47	Power Card Ordering No	0 N/A	All set-ups	FALSE	0	VisStr[8]
15-48	LCP Id No	0 N/A	All set-ups	FALSE	0	VisStr[20]
15-49	SW ID Control Card	0 N/A	All set-ups	FALSE	0	VisStr[20]
15-50	SW ID Power Card	0 N/A	All set-ups	FALSE	0	VisStr[20]
15-51	Frequency Converter Serial Number	0 N/A	All set-ups	FALSE	0	VisStr[10]
15-53	Power Card Serial Number	0 N/A	All set-ups	FALSE	0	VisStr[19]

Par. No. #	Parameter description	Default value	4-set-up	Change during operation	Conversion index	Type
15-6* Option Ident						
15-60	Option Mounted	0 N/A	All set-ups	FALSE	0	VisStr[30]
15-61	Option SW Version	0 N/A	All set-ups	FALSE	0	VisStr[20]
15-62	Option Ordering No	0 N/A	All set-ups	FALSE	0	VisStr[8]
15-63	Option Serial No	0 N/A	All set-ups	FALSE	0	VisStr[18]
15-70	Option in Slot A	0 N/A	All set-ups	FALSE	0	VisStr[30]
15-71	Slot A Option SW Version	0 N/A	All set-ups	FALSE	0	VisStr[20]
15-72	Option in Slot B	0 N/A	All set-ups	FALSE	0	VisStr[30]
15-73	Slot B Option SW Version	0 N/A	All set-ups	FALSE	0	VisStr[20]
15-74	Option in Slot C0	0 N/A	All set-ups	FALSE	0	VisStr[30]
15-75	Slot C0 Option SW Version	0 N/A	All set-ups	FALSE	0	VisStr[20]
15-76	Option in Slot C1	0 N/A	All set-ups	FALSE	0	VisStr[30]
15-77	Slot C1 Option SW Version	0 N/A	All set-ups	FALSE	0	VisStr[20]
15-9* Parameter Info						
15-92	Defined Parameters	0 N/A	All set-ups	FALSE	0	Uint16
15-93	Modified Parameters	0 N/A	All set-ups	FALSE	0	Uint16
15-99	Parameter Metadata	0 N/A	All set-ups	FALSE	0	Uint16

7.2.13 16-** Data Readouts

Par. No. #	Parameter description	Default value	4-set-up	Change during operation	Conversion index	Type
16-0* General Status						
16-00	Control Word	0 N/A	All set-ups	FALSE	0	V2
16-01	Reference [Unit]	0.000 ReferenceFeedbackUnit	All set-ups	FALSE	-3	Int32
16-02	Reference [%]	0.0 %	All set-ups	FALSE	-1	Int16
16-03	Status Word	0 N/A	All set-ups	FALSE	0	V2
16-05	Main Actual Value [%]	0.00 %	All set-ups	FALSE	-2	N2
16-09	Custom Readout	0.00 CustomReadoutUnit	All set-ups	FALSE	-2	Int32
16-1* Motor Status						
16-10	Power [kW]	0.00 kW	All set-ups	FALSE	1	Int32
16-11	Power [hp]	0.00 hp	All set-ups	FALSE	-2	Int32
16-12	Motor Voltage	0.0 V	All set-ups	FALSE	-1	Uint16
16-13	Frequency	0.0 Hz	All set-ups	FALSE	-1	Uint16
16-14	Motor Current	0.00 A	All set-ups	FALSE	-2	Int32
16-15	Frequency [%]	0.00 %	All set-ups	FALSE	-2	N2
16-16	Torque [Nm]	0.0 Nm	All set-ups	FALSE	-1	Int16
16-17	Speed [RPM]	0 RPM	All set-ups	FALSE	67	Int32
16-18	Motor Thermal	0 %	All set-ups	FALSE	0	Uint8
16-22	Torque [%]	0 %	All set-ups	FALSE	0	Int16
16-3* Drive Status						
16-30	DC Link Voltage	0 V	All set-ups	FALSE	0	Uint16
16-32	Brake Energy /s	0.000 kW	All set-ups	FALSE	0	Uint32
16-33	Brake Energy /2 min	0.000 kW	All set-ups	FALSE	0	Uint32
16-34	Heatsink Temp.	0 °C	All set-ups	FALSE	100	Uint8
16-35	Inverter Thermal	0 %	All set-ups	FALSE	0	Uint8
16-36	Inv. Nom. Current	ExpressionLimit	All set-ups	FALSE	-2	Uint32
16-37	Inv. Max. Current	ExpressionLimit	All set-ups	FALSE	-2	Uint32
16-38	SL Controller State	0 N/A	All set-ups	FALSE	0	Uint8
16-39	Control Card Temp.	0 °C	All set-ups	FALSE	100	Uint8
16-40	Logging Buffer Full	[0] No	All set-ups	TRUE	-	Uint8
16-5* Ref. & Feeds						
16-50	External Reference	0.0 N/A	All set-ups	FALSE	-1	Int16
16-52	Feedback [Unit]	0.000 ProcessCtrlUnit	All set-ups	FALSE	-3	Int32
16-53	Digi. Pot Reference	0.00 N/A	All set-ups	FALSE	-2	Int16
16-54	Feedback 1 [Unit]	0.000 ProcessCtrlUnit	All set-ups	FALSE	-3	Int32
16-55	Feedback 2 [Unit]	0.000 ProcessCtrlUnit	All set-ups	FALSE	-3	Int32
16-56	Feedback 3 [Unit]	0.000 ProcessCtrlUnit	All set-ups	FALSE	-3	Int32

Par. No. #	Parameter description	Default value	4-set-up	Change during operation	Conversion index	Type
16-6* Inputs & Outputs						
16-60	Digital Input	0 N/A	All set-ups	FALSE	0	Uint16
16-61	Terminal 53 Switch Setting	[0] Current	All set-ups	FALSE	-	Uint8
16-62	Analog Input 53	0.000 N/A	All set-ups	FALSE	-3	Int32
16-63	Terminal 54 Switch Setting	[0] Current	All set-ups	FALSE	-	Uint8
16-64	Analog Input 54	0.000 N/A	All set-ups	FALSE	-3	Int32
16-65	Analog Output 42 [mA]	0.000 N/A	All set-ups	FALSE	-3	Int16
16-66	Digital Output [bin]	0 N/A	All set-ups	FALSE	0	Int16
16-67	Pulse Input #29 [Hz]	0 N/A	All set-ups	FALSE	0	Int32
16-68	Pulse Input #33 [Hz]	0 N/A	All set-ups	FALSE	0	Int32
16-69	Pulse Output #27 [Hz]	0 N/A	All set-ups	FALSE	0	Int32
16-70	Pulse Output #29 [Hz]	0 N/A	All set-ups	FALSE	0	Int32
16-71	Relay Output [bin]	0 N/A	All set-ups	FALSE	0	Int16
16-72	Counter A	0 N/A	All set-ups	TRUE	0	Int32
16-73	Counter B	0 N/A	All set-ups	TRUE	0	Int32
16-75	Analog In X30/11	0.000 N/A	All set-ups	FALSE	-3	Int32
16-76	Analog In X30/12	0.000 N/A	All set-ups	FALSE	-3	Int32
16-77	Analog Out X30/8 [mA]	0.000 N/A	All set-ups	FALSE	-3	Int16
16-8* Fieldbus & FC Port						
16-80	Fieldbus CTW 1	0 N/A	All set-ups	FALSE	0	V2
16-82	Fieldbus REF 1	0 N/A	All set-ups	FALSE	0	N2
16-84	Comm. Option STW	0 N/A	All set-ups	FALSE	0	V2
16-85	FC Port CTW 1	0 N/A	All set-ups	FALSE	0	V2
16-86	FC Port REF 1	0 N/A	All set-ups	FALSE	0	N2
16-9* Diagnosis Readouts						
16-90	Alarm Word	0 N/A	All set-ups	FALSE	0	Uint32
16-91	Alarm Word 2	0 N/A	All set-ups	FALSE	0	Uint32
16-92	Warning Word	0 N/A	All set-ups	FALSE	0	Uint32
16-93	Warning Word 2	0 N/A	All set-ups	FALSE	0	Uint32
16-94	Ext. Status Word	0 N/A	All set-ups	FALSE	0	Uint32
16-95	Ext. Status Word 2	0 N/A	All set-ups	FALSE	0	Uint32
16-96	Maintenance Word	0 N/A	All set-ups	FALSE	0	Uint32

7.2.14 18-** Info & Readouts

Par. No. #	Parameter description	Default value	4-set-up	Change during operation	Conversion index	Type
18-0* Maintenance Log						
18-00	Maintenance Log: Item	0 N/A	All set-ups	FALSE	0	Uint8
18-01	Maintenance Log: Action	0 N/A	All set-ups	FALSE	0	Uint8
18-02	Maintenance Log: Time	0 s	All set-ups	FALSE	0	Uint32
18-03	Maintenance Log: Date and Time	ExpressionLimit	All set-ups	FALSE	0	TimeOfDay
18-1* Fire Mode Log						
18-10	Fire Mode Log: Event	0 N/A	All set-ups	FALSE	0	Uint8
18-11	Fire Mode Log: Time	0 s	All set-ups	FALSE	0	Uint32
18-12	Fire Mode Log: Date and Time	ExpressionLimit	All set-ups	FALSE	0	TimeOfDay
18-3* Inputs & Outputs						
18-30	Analog Input X42/1	0.000 N/A	All set-ups	FALSE	-3	Int32
18-31	Analog Input X42/3	0.000 N/A	All set-ups	FALSE	-3	Int32
18-32	Analog Input X42/5	0.000 N/A	All set-ups	FALSE	-3	Int32
18-33	Analog Out X42/7 [V]	0.000 N/A	All set-ups	FALSE	-3	Int16
18-34	Analog Out X42/9 [V]	0.000 N/A	All set-ups	FALSE	-3	Int16
18-35	Analog Out X42/11 [V]	0.000 N/A	All set-ups	FALSE	-3	Int16

7.2.15 20-** FC Closed Loop

7

Par. No. #	Parameter description	Default value	4-set-up	Change during operation	Conversion index	Type
20-0* Feedback						
20-00	Feedback 1 Source	[2] Analog input 54	All set-ups	TRUE	-	Uint8
20-01	Feedback 1 Conversion	[2] Pressure to temperature	All set-ups	FALSE	-	Uint8
20-02	Feedback 1 Source Unit	null	All set-ups	TRUE	-	Uint8
20-03	Feedback 2 Source	[0] No function	All set-ups	TRUE	-	Uint8
20-04	Feedback 2 Conversion	[0] Linear	All set-ups	FALSE	-	Uint8
20-05	Feedback 2 Source Unit	null	All set-ups	TRUE	-	Uint8
20-06	Feedback 3 Source	[0] No function	All set-ups	TRUE	-	Uint8
20-07	Feedback 3 Conversion	[0] Linear	All set-ups	FALSE	-	Uint8
20-08	Feedback 3 Source Unit	null	All set-ups	TRUE	-	Uint8
20-12	Reference/Feedback Unit	null	All set-ups	TRUE	-	Uint8
20-2* Feedback/Setpoint						
20-20	Feedback Function	[3] Minimum	All set-ups	TRUE	-	Uint8
20-21	Setpoint 1	0 ProcessCtrlUnit	All set-ups	TRUE	-3	Int32
20-22	Setpoint 2	0.000 ProcessCtrlUnit	All set-ups	TRUE	-3	Int32
20-23	Setpoint 3	0.000 ProcessCtrlUnit	All set-ups	TRUE	-3	Int32
20-25	Setpoint Type	null	All set-ups	TRUE	-	Uint8
20-3* Feedback Adv. Conv						
20-30	Refrigerant	[19] R404A	All set-ups	TRUE	-	Uint8
20-31	User Defined Refrigerant A1	10.0000 N/A	All set-ups	TRUE	-4	Uint32
20-32	User Defined Refrigerant A2	-2250.00 N/A	All set-ups	TRUE	-2	Int32
20-33	User Defined Refrigerant A3	250.0000 N/A	All set-ups	TRUE	-3	Uint32
20-4* Thermostat/Pressostat						
20-40	Thermostat/Pressostat Function	null	All set-ups	FALSE	-	Uint8
20-41	Cut-out Value	ExpressionLimit	All set-ups	TRUE	-3	Int32
20-42	Cut-in Value	ExpressionLimit	All set-ups	TRUE	-3	Int32
20-7* PID Autotuning						
20-70	Closed Loop Type	[0] Auto	2 set-ups	TRUE	-	Uint8
20-71	PID Performance	[0] Normal	2 set-ups	TRUE	-	Uint8
20-72	PID Output Change	0.10 N/A	2 set-ups	TRUE	-2	Uint16
20-73	Minimum Feedback Level	-999999.000 ProcessCtrlUnit	2 set-ups	TRUE	-3	Int32
20-74	Maximum Feedback Level	999999.000 ProcessCtrlUnit	2 set-ups	TRUE	-3	Int32
20-79	PID Autotuning	[0] Disabled	All set-ups	TRUE	-	Uint8
20-8* PID Basic Settings						
20-81	PID Normal/ Inverse Control	[1] Inverse	All set-ups	TRUE	-	Uint8
20-82	PID Start Speed [RPM]	ExpressionLimit	All set-ups	TRUE	67	Uint16
20-83	PID Start Speed [Hz]	ExpressionLimit	All set-ups	TRUE	-1	Uint16
20-84	On Reference Bandwidth	5 %	All set-ups	TRUE	0	Uint8
20-9* PID Controller						
20-91	PID Anti Windup	[1] On	All set-ups	TRUE	-	Uint8
20-93	PID Proportional Gain	0.50 N/A	All set-ups	TRUE	-2	Uint16
20-94	PID Integral Time	30.00 s	All set-ups	TRUE	-2	Uint32
20-95	PID Differentiation Time	0.00 s	All set-ups	TRUE	-2	Uint16
20-96	PID Diff. Gain Limit	5.0 N/A	All set-ups	TRUE	-1	Uint16

7.2.16 21-** Ext. Closed Loop

Par. No. #	Parameter description	Default value	4-set-up	Change during operation	Conversion index	Type
21-0* Ext. CL Autotuning						
21-00	Closed Loop Type	[0] Auto	2 set-ups	TRUE	-	Uint8
21-01	PID Performance	[0] Normal	2 set-ups	TRUE	-	Uint8
21-02	PID Output Change	0.10 N/A	2 set-ups	TRUE	-2	Uint16
21-03	Minimum Feedback Level	-999999.000 N/A	2 set-ups	TRUE	-3	Int32
21-04	Maximum Feedback Level	999999.000 N/A	2 set-ups	TRUE	-3	Int32
21-09	PID Autotuning	[0] Disabled	All set-ups	TRUE	-	Uint8
21-1* Ext. CL 1 Ref/Fb.						
21-10	Ext. 1 Ref/Feedback Unit	[1] %	All set-ups	TRUE	-	Uint8
21-11	Ext. 1 Minimum Reference	0.000 ExpPID1Unit	All set-ups	TRUE	-3	Int32
21-12	Ext. 1 Maximum Reference	100.000 ExpPID1Unit	All set-ups	TRUE	-3	Int32
21-13	Ext. 1 Reference Source	[0] No function	All set-ups	TRUE	-	Uint8
21-14	Ext. 1 Feedback Source	[0] No function	All set-ups	TRUE	-	Uint8
21-15	Ext. 1 Setpoint	0.000 ExpPID1Unit	All set-ups	TRUE	-3	Int32
21-17	Ext. 1 Reference [Unit]	0.000 ExpPID1Unit	All set-ups	TRUE	-3	Int32
21-18	Ext. 1 Feedback [Unit]	0.000 ExpPID1Unit	All set-ups	TRUE	-3	Int32
21-19	Ext. 1 Output [%]	0 %	All set-ups	TRUE	0	Int32
21-2* Ext. CL 1 PID						
21-20	Ext. 1 Normal/Inverse Control	[0] Normal	All set-ups	TRUE	-	Uint8
21-21	Ext. 1 Proportional Gain	0.01 N/A	All set-ups	TRUE	-2	Uint16
21-22	Ext. 1 Integral Time	10000.00 s	All set-ups	TRUE	-2	Uint32
21-23	Ext. 1 Differentiation Time	0.00 s	All set-ups	TRUE	-2	Uint16
21-24	Ext. 1 Dif. Gain Limit	5.0 N/A	All set-ups	TRUE	-1	Uint16
21-3* Ext. CL 2 Ref/Fb.						
21-30	Ext. 2 Ref/Feedback Unit	[1] %	All set-ups	TRUE	-	Uint8
21-31	Ext. 2 Minimum Reference	0.000 ExpPID2Unit	All set-ups	TRUE	-3	Int32
21-32	Ext. 2 Maximum Reference	100.000 ExpPID2Unit	All set-ups	TRUE	-3	Int32
21-33	Ext. 2 Reference Source	[0] No function	All set-ups	TRUE	-	Uint8
21-34	Ext. 2 Feedback Source	[0] No function	All set-ups	TRUE	-	Uint8
21-35	Ext. 2 Setpoint	0.000 ExpPID2Unit	All set-ups	TRUE	-3	Int32
21-37	Ext. 2 Reference [Unit]	0.000 ExpPID2Unit	All set-ups	TRUE	-3	Int32
21-38	Ext. 2 Feedback [Unit]	0.000 ExpPID2Unit	All set-ups	TRUE	-3	Int32
21-39	Ext. 2 Output [%]	0 %	All set-ups	TRUE	0	Int32
21-4* Ext. CL 2 PID						
21-40	Ext. 2 Normal/Inverse Control	[0] Normal	All set-ups	TRUE	-	Uint8
21-41	Ext. 2 Proportional Gain	0.01 N/A	All set-ups	TRUE	-2	Uint16
21-42	Ext. 2 Integral Time	10000.00 s	All set-ups	TRUE	-2	Uint32
21-43	Ext. 2 Differentiation Time	0.00 s	All set-ups	TRUE	-2	Uint16
21-44	Ext. 2 Dif. Gain Limit	5.0 N/A	All set-ups	TRUE	-1	Uint16

Par. No. #	Parameter description	Default value	4-set-up	Change during operation	Conversion index	Type
21-5* Ext. CL 3 Ref/Fb.						
21-50	Ext. 3 Ref./Feedback Unit	[1] %	All set-ups	TRUE	-	Uint8
21-51	Ext. 3 Minimum Reference	0.000 ExtPID3Unit	All set-ups	TRUE	-3	Int32
21-52	Ext. 3 Maximum Reference	100.000 ExtPID3Unit	All set-ups	TRUE	-3	Int32
21-53	Ext. 3 Reference Source	[0] No function	All set-ups	TRUE	-	Uint8
21-54	Ext. 3 Feedback Source	[0] No function	All set-ups	TRUE	-	Uint8
21-55	Ext. 3 Setpoint	0.000 ExtPID3Unit	All set-ups	TRUE	-3	Int32
21-57	Ext. 3 Reference [Unit]	0.000 ExtPID3Unit	All set-ups	TRUE	-3	Int32
21-58	Ext. 3 Feedback [Unit]	0.000 ExtPID3Unit	All set-ups	TRUE	-3	Int32
21-59	Ext. 3 Output [%]	0 %	All set-ups	TRUE	0	Int32
21-6* Ext. CL 3 PID						
21-60	Ext. 3 Normal/Inverse Control	[0] Normal	All set-ups	TRUE	-	Uint8
21-61	Ext. 3 Proportional Gain	0.01 N/A	All set-ups	TRUE	-2	Uint16
21-62	Ext. 3 Integral Time	10000.00 s	All set-ups	TRUE	-2	Uint32
21-63	Ext. 3 Differentiation Time	0.00 s	All set-ups	TRUE	-2	Uint16
21-64	Ext. 3 Dif. Gain Limit	5.0 N/A	All set-ups	TRUE	-1	Uint16

7.2.17 22-** Application Functions

Par. No. #	Parameter description	Default value	4-set-up	Change during operation	Conversion index	Type
22-0* Miscellaneous						
22-00	External Interlock Delay	0 s	All set-ups	TRUE	0	Ujnt16
22-2* No-Flow Detection						
22-20	Low Power Auto Set-up	[0] Off	All set-ups	FALSE	-	Ujnt8
22-21	Low Power Detection	[0] Disabled	All set-ups	TRUE	-	Ujnt8
22-22	Low Speed Detection	[0] Disabled	All set-ups	TRUE	-	Ujnt8
22-23	No-Flow Function	[0] Off	All set-ups	TRUE	-	Ujnt8
22-24	No-Flow Delay	10 s	All set-ups	TRUE	0	Ujnt16
22-26	Dry Pump Function	[0] Off	All set-ups	TRUE	-	Ujnt8
22-27	Dry Pump Delay	10 s	All set-ups	TRUE	0	Ujnt16
22-3* No-Flow Power Tuning						
22-30	No-Flow Power	0.00 kW	All set-ups	TRUE	1	Ujnt32
22-31	Power Correction Factor	100 %	All set-ups	TRUE	0	Ujnt16
22-32	Low Speed [RPM]	ExpressionLimit	All set-ups	TRUE	67	Ujnt16
22-33	Low Speed [Hz]	ExpressionLimit	All set-ups	TRUE	-1	Ujnt16
22-34	Low Speed Power [kW]	ExpressionLimit	All set-ups	TRUE	1	Ujnt32
22-35	Low Speed Power [HP]	ExpressionLimit	All set-ups	TRUE	-2	Ujnt32
22-36	High Speed [RPM]	ExpressionLimit	All set-ups	TRUE	67	Ujnt16
22-37	High Speed [Hz]	ExpressionLimit	All set-ups	TRUE	-1	Ujnt16
22-38	High Speed Power [kW]	ExpressionLimit	All set-ups	TRUE	1	Ujnt32
22-39	High Speed Power [HP]	ExpressionLimit	All set-ups	TRUE	-2	Ujnt32
22-4* Sleep Mode						
22-40	Minimum Run Time	10 s	All set-ups	TRUE	0	Ujnt16
22-41	Minimum Sleep Time	10 s	All set-ups	TRUE	0	Ujnt16
22-42	Wake-up Speed [RPM]	ExpressionLimit	All set-ups	TRUE	67	Ujnt16
22-43	Wake-up Speed [Hz]	ExpressionLimit	All set-ups	TRUE	-1	Ujnt16
22-44	Wake-up Ref./FB Difference	10 %	All set-ups	TRUE	0	Int8
22-45	Setpoint Boost	0 %	All set-ups	TRUE	0	Int8
22-46	Maximum Boost Time	60 s	All set-ups	TRUE	0	Ujnt16
22-5* End of Curve						
22-50	End of Curve Function	[0] Off	All set-ups	TRUE	-	Ujnt8
22-51	End of Curve Delay	10 s	All set-ups	TRUE	0	Ujnt16
22-6* Broken Belt Detection						
22-60	Broken Belt Function	[0] Off	All set-ups	TRUE	-	Ujnt8
22-61	Broken Belt Torque	10 %	All set-ups	TRUE	0	Ujnt8
22-62	Broken Belt Delay	10 s	All set-ups	TRUE	0	Ujnt16
22-7* Short Cycle Protection						
22-75	Short Cycle Protection	[0] Disabled	All set-ups	TRUE	-	Ujnt8
22-76	Interval between Starts	300 s	All set-ups	TRUE	0	Ujnt16
22-77	Minimum Run Time	0 s	All set-ups	TRUE	0	Ujnt16

Par. No. #	Parameter description	Default value	4-set-up	Change during operation	Conversion index	Type
22-8* Flow Compensation						
22-80	Flow Compensation	[0] Disabled	All set-ups	TRUE	-	Uint8
22-81	Square-linear Curve Approximation	100 %	All set-ups	TRUE	0	Uint8
22-82	Work Point Calculation	[0] Disabled	All set-ups	TRUE	-	Uint8
22-83	Speed at No-Flow [RPM]	ExpressionLimit	All set-ups	TRUE	67	Uint16
22-84	Speed at No-Flow [Hz]	ExpressionLimit	All set-ups	TRUE	-1	Uint16
22-85	Speed at Design Point [RPM]	ExpressionLimit	All set-ups	TRUE	67	Uint16
22-86	Speed at Design Point [Hz]	ExpressionLimit	All set-ups	TRUE	-1	Uint16
22-87	Pressure at No-Flow Speed	0.000 N/A	All set-ups	TRUE	-3	Int32
22-88	Pressure at Rated Speed	999999.000 N/A	All set-ups	TRUE	-3	Int32
22-89	Flow at Design Point	0.000 N/A	All set-ups	TRUE	-3	Int32
22-90	Flow at Rated Speed	0.000 N/A	All set-ups	TRUE	-3	Int32

7.2.18 23-** Time Based Funtions

Par. No. #	Parameter description	Default value	4-set-up	Change during operation	Conversion index	Type
23-0* Timed Actions						
23-00	ON Time	ExpressionLimit	2 set-ups	TRUE	0	TimeOfDay- WoDate Uint8
23-01	ON Action	[0] Disabled	2 set-ups	TRUE	-	Uint8
23-02	OFF Time	ExpressionLimit	2 set-ups	TRUE	0	TimeOfDay- WoDate Uint8
23-03	OFF Action	[0] Disabled	2 set-ups	TRUE	-	Uint8
23-04	Occurrence	[0] All days	2 set-ups	TRUE	-	Uint8
23-1* Maintenance						
23-10	Maintenance Item	[1] Motor bearings	1 set-up	TRUE	-	Uint8
23-11	Maintenance Action	[1] Lubricate	1 set-up	TRUE	-	Uint8
23-12	Maintenance Time Base	[0] Lubricate	1 set-up	TRUE	-	Uint8
23-13	Maintenance Time Interval	1 h	1 set-up	TRUE	74	Uint32
23-14	Maintenance Date and Time	ExpressionLimit	1 set-up	TRUE	0	TimeOfDay
23-1* Maintenance Reset						
23-15	Reset Maintenance Word	[0] Do not reset	All set-ups	TRUE	-	Uint8
23-5* Energy Log						
23-50	Energy Log Resolution	[5] Last 24 Hours	2 set-ups	TRUE	-	Uint8
23-51	Period Start	ExpressionLimit	2 set-ups	TRUE	0	TimeOfDay
23-53	Energy Log	0 N/A	All set-ups	TRUE	0	Uint32
23-54	Reset Energy Log	[0] Do not reset	All set-ups	TRUE	-	Uint8
23-6* Trending						
23-60	Trend Variable	[0] Power [kW]	2 set-ups	TRUE	-	Uint8
23-61	Continuous Bin Data	0 N/A	All set-ups	TRUE	0	Uint32
23-62	Timed Bin Data	0 N/A	All set-ups	TRUE	0	Uint32
23-63	Timed Period Start	ExpressionLimit	2 set-ups	TRUE	0	TimeOfDay
23-64	Timed Period Stop	ExpressionLimit	2 set-ups	TRUE	0	TimeOfDay
23-65	Minimum Bin Value	ExpressionLimit	2 set-ups	TRUE	0	Uint8
23-66	Reset Continuous Bin Data	[0] Do not reset	All set-ups	TRUE	-	Uint8
23-67	Reset Timed Bin Data	[0] Do not reset	All set-ups	TRUE	-	Uint8
23-8* Payback Counter						
23-80	Power Reference Factor	100 %	2 set-ups	TRUE	0	Uint8
23-81	Energy Cost	1.00 N/A	2 set-ups	TRUE	-2	Uint32
23-82	Investment	0 N/A	2 set-ups	TRUE	0	Uint32
23-83	Energy Savings	0 kWh	All set-ups	TRUE	75	Int32
23-84	Cost Savings	0 N/A	All set-ups	TRUE	0	Int32

7.2.19 25-**-** Pack Controller

7

Par. No. #	Parameter description	Default value	4-set-up	Change during operation	Conversion index	Type
25-0* System Settings						
25-00	Pack Controller	[0] Disabled	2 set-ups	FALSE	-	Uint8
25-04	Compressor Cycling	[0] Disabled	All set-ups	TRUE	-	Uint8
25-06	Number of Compressors	2 N/A	2 set-ups	FALSE	0	Uint8
25-2* Zone Settings						
25-20	Neutral Zone [unit]	4.00 ReferenceFeedbackUnit	All set-ups	TRUE	-2	Uint32
25-21	+ Zone [unit]	3.00 ReferenceFeedbackUnit	All set-ups	TRUE	-2	Uint32
25-22	- Zone [unit]	3.00 ReferenceFeedbackUnit	All set-ups	TRUE	-2	Uint32
25-23	Fixed Speed neutral Zone [unit]	4.00 ReferenceFeedbackUnit	All set-ups	TRUE	-2	Uint32
25-24	+ Zone Delay	120 s	All set-ups	TRUE	0	Uint32
25-25	- Zone Delay	60 s	All set-ups	TRUE	0	Uint32
25-26	++ Zone Delay	60 s	All set-ups	TRUE	0	Uint32
25-27	-- Zone Delay	30 s	All set-ups	TRUE	0	Uint32
25-3* Staging Functions						
25-30	Destage At No-Flow	[0] Disabled	All set-ups	TRUE	-	Uint8
25-31	Stage Function	[0] Disabled	All set-ups	TRUE	-	Uint8
25-32	Stage Function Time	15 s	All set-ups	TRUE	0	Uint16
25-33	Destage Function	[0] Disabled	All set-ups	TRUE	-	Uint8
25-34	Destage Function Time	15 s	All set-ups	TRUE	0	Uint16
25-4* Staging Settings						
25-40	Ramp Down Delay	10.0 s	All set-ups	TRUE	-1	Uint16
25-41	Ramp Up Delay	2.0 s	All set-ups	TRUE	-1	Uint16
25-42	Staging Threshold	ExpressionLimit	All set-ups	TRUE	0	Uint8
25-43	Destaging Threshold	ExpressionLimit	All set-ups	TRUE	0	Uint8
25-44	Staging Speed [RPM]	0 RPM	All set-ups	TRUE	67	Uint16
25-45	Staging Speed [Hz]	0.0 Hz	All set-ups	TRUE	-1	Uint16
25-46	Destaging Speed [RPM]	0 RPM	All set-ups	TRUE	67	Uint16
25-47	Destaging Speed [Hz]	0.0 Hz	All set-ups	TRUE	-1	Uint16
25-80	Pack Status	0 N/A	All set-ups	TRUE	0	VisStr[25]
25-81	Compressor Status	0 N/A	All set-ups	TRUE	0	VisStr[25]
25-82	Lead Compressor	0 N/A	All set-ups	TRUE	0	Uint8
25-83	Relay Status	0 N/A	All set-ups	TRUE	0	Uint8
25-84	Compressor ON Time	0 h	All set-ups	TRUE	74	Uint32
25-85	Relay ON Time	0 h	All set-ups	TRUE	74	Uint32
25-86	Reset Relay Counters	[0] Do not reset	All set-ups	TRUE	-	Uint8
25-87	Inverse Interlock	0 N/A	All set-ups	TRUE	0	Uint16
25-9* Service						
25-90	Compressor Interlock	[0] Off	All set-ups	TRUE	-	Uint8
25-91	Manual Alternation	0 N/A	All set-ups	TRUE	0	Uint8

7.2.20 26-** Analog I / O Option MCB 109

Par. No. #	Parameter description	Default value	4-set-up	Change during operation	Conversion index	Type
26-0* Analog I/O Mode						
26-00	Terminal X42/1 Mode	[1] Voltage	All set-ups	TRUE	-	Uint8
26-01	Terminal X42/3 Mode	[1] Voltage	All set-ups	TRUE	-	Uint8
26-02	Terminal X42/5 Mode	[1] Voltage	All set-ups	TRUE	-	Uint8
26-1* Analog Input X42/1						
26-10	Terminal X42/1 Low Voltage	0.07 V	All set-ups	TRUE	-2	Int16
26-11	Terminal X42/1 High Voltage	10.00 V	All set-ups	TRUE	-2	Int16
26-14	Term. X42/1 Low Ref./Feedb. Value	0.000 N/A	All set-ups	TRUE	-3	Int32
26-15	Term. X42/1 High Ref./Feedb. Value	100.000 N/A	All set-ups	TRUE	-3	Int32
26-16	Term. X42/1 Filter Time Constant	0.001 s	All set-ups	TRUE	-3	Uint16
26-17	Term. X42/1 Live Zero	[1] Enabled	All set-ups	TRUE	-	Uint8
26-2* Analog Input X42/3						
26-20	Terminal X42/3 Low Voltage	0.07 V	All set-ups	TRUE	-2	Int16
26-21	Terminal X42/3 High Voltage	10.00 V	All set-ups	TRUE	-2	Int16
26-24	Term. X42/3 Low Ref./Feedb. Value	0.000 N/A	All set-ups	TRUE	-3	Int32
26-25	Term. X42/3 High Ref./Feedb. Value	100.000 N/A	All set-ups	TRUE	-3	Int32
26-26	Term. X42/3 Filter Time Constant	0.001 s	All set-ups	TRUE	-3	Uint16
26-27	Term. X42/3 Live Zero	[1] Enabled	All set-ups	TRUE	-	Uint8
26-3* Analog Input X42/5						
26-30	Terminal X42/5 Low Voltage	0.07 V	All set-ups	TRUE	-2	Int16
26-31	Terminal X42/5 High Voltage	10.00 V	All set-ups	TRUE	-2	Int16
26-34	Term. X42/5 Low Ref./Feedb. Value	0.000 N/A	All set-ups	TRUE	-3	Int32
26-35	Term. X42/5 High Ref./Feedb. Value	100.000 N/A	All set-ups	TRUE	-3	Int32
26-36	Term. X42/5 Filter Time Constant	0.001 s	All set-ups	TRUE	-3	Uint16
26-37	Term. X42/5 Live Zero	[1] Enabled	All set-ups	TRUE	-	Uint8
26-4* Analog Out X42/7						
26-40	Terminal X42/7 Output	[0] No operation	All set-ups	TRUE	-	Uint8
26-41	Terminal X42/7 Min. Scale	0.00 %	All set-ups	TRUE	-2	Int16
26-42	Terminal X42/7 Max. Scale	100.00 %	All set-ups	TRUE	-2	Int16
26-43	Terminal X42/7 Bus Control	0.00 %	All set-ups	TRUE	-2	N2
26-44	Terminal X42/7 Timeout Preset	0.00 %	1 set-up	TRUE	-2	Uint16
26-5* Analog Out X42/9						
26-50	Terminal X42/9 Output	[0] No operation	All set-ups	TRUE	-	Uint8
26-51	Terminal X42/9 Min. Scale	0.00 %	All set-ups	TRUE	-2	Int16
26-52	Terminal X42/9 Max. Scale	100.00 %	All set-ups	TRUE	-2	Int16
26-53	Terminal X42/9 Bus Control	0.00 %	All set-ups	TRUE	-2	N2
26-54	Terminal X42/9 Timeout Preset	0.00 %	1 set-up	TRUE	-2	Uint16
26-6* Analog Out X42/11						
26-60	Terminal X42/11 Output	[0] No operation	All set-ups	TRUE	-	Uint8
26-61	Terminal X42/11 Min. Scale	0.00 %	All set-ups	TRUE	-2	Int16
26-62	Terminal X42/11 Max. Scale	100.00 %	All set-ups	TRUE	-2	Int16
26-63	Terminal X42/11 Bus Control	0.00 %	All set-ups	TRUE	-2	N2
26-64	Terminal X42/11 Timeout Preset	0.00 %	1 set-up	TRUE	-2	Uint16

7.2.21 28-** Compressor Functions

7

Par. No. #	Parameter description	Default value	4-set-up	Change during operation	Conversion index	Type
28-2* Discharge Temperature Monitor						
28-20	Temperature Source	[0] None	All set-ups	FALSE	-	Uint8
28-21	Temperature Unit	[60] °C	All set-ups	FALSE	-	Uint8
28-24	Warning Level	130 N/A	All set-ups	FALSE	0	Uint16
28-25	Warning Action	[1] Decrease cooling	All set-ups	FALSE	-	Uint8
28-26	Emergency Level	145 N/A	All set-ups	FALSE	0	Uint16
28-27	Discharge Temperature	0 DTM_ReadoutUnit	All set-ups	TRUE	0	Int32
28-7* Day/Night Settings						
28-71	Day/Night Bus Indicator	[0] Day	All set-ups	TRUE	-	Uint8
28-72	Enable Day/Night Via Bus	[0] Disabled	All set-ups	TRUE	-	Uint8
28-73	Night Setback	0.000 ReferenceFeedbackUnit	All set-ups	TRUE	-3	Int32
28-74	Night Speed Drop [RPM]	ExpressionLimit	All set-ups	TRUE	67	Uint16
28-75	Night Speed Drop Override	0.000 N/A	All set-ups	TRUE	-3	Int32
28-76	Night Speed Drop [Hz]	ExpressionLimit	All set-ups	TRUE	-1	Uint16
28-8* PO Optimization						
28-81	dPO Offset	0.0 K	All set-ups	TRUE	-1	Int32
28-82	P0	0.000 K	All set-ups	TRUE	-3	Int32
28-83	P0 Setpoint	0.000 K	All set-ups	TRUE	-3	Int32
28-84	P0 Reference	0.000 K	All set-ups	TRUE	-3	Int32
28-85	P0 Minimum Reference	0 K	All set-ups	TRUE	0	Int32
28-86	P0 Maximum Reference	0 K	All set-ups	TRUE	0	Int32
28-87	Most Loaded Controller	0 N/A	All set-ups	TRUE	0	Int16
28-9* Injection Control						
28-90	Injection On	[0] Off	All set-ups	TRUE	-	Uint8
28-91	Delayed Compressor Start	[0] No	All set-ups	TRUE	-	Uint8

8 Troubleshooting

8.1 Alarms and warnings

A warning or an alarm is signalled by the relevant LED on the front of the frequency converter and indicated by a code on the display.

A warning remains active until its cause is no longer present. Under certain circumstances operation of the motor may still be continued. Warning messages may be critical, but are not necessarily so.

In the event of an alarm, the frequency converter will have tripped. Alarms must be reset to restart operation once their cause has been rectified. This may be done in four ways:

1. By using the [RESET] control button on the LCP control panel.
2. Via a digital input with the "Reset" function.
3. Via serial communication/optional fieldbus.
4. By resetting automatically using the [Auto Reset] function, which is a default setting for ADAP-KOOL Drive. see par. 14-20 *Reset Mode* in *AKD 102 Programming Guide, MG.11.Mx.yy*

NOTE

After a manual reset using the [RESET] button on the LCP, the [AUTO ON] button must be pressed to restart the motor.

If an alarm cannot be reset, the reason may be that its cause has not been rectified, or the alarm is trip-locked (see also table on following page).

Alarms that are trip-locked offer additional protection, since the mains supply must be switched off before the alarm can be reset. After being switched back on, the frequency converter is no longer blocked and may be reset as described above once the cause has been rectified.

Alarms that are not trip-locked can also be reset using the automatic reset function in par. 14-20 (Warning: automatic wake-up is possible!)

If a warning and alarm is marked against a code in the table on the following page, this means that either a warning occurs before an alarm, or it can be specified whether it is a warning or an alarm that is to be displayed for a given fault.

This is possible, for instance, in par. 1-90 *Motor Thermal Protection*. After an alarm or trip, the motor carries on coasting, and the alarm and warning flash on the frequency converter. Once the problem has been rectified, only the alarm continues flashing.

No.	Description	Warning	Alarm/Trip	Alarm/Trip Lock	Parameter Reference
1	10 Volts low	X			
2	Live zero error	(X)	(X)		6-01
3	No motor	(X)			1-80
4	Mains phase loss	(X)	(X)	(X)	14-12
5	DC link voltage high	X			
6	DC link voltage low	X			
7	DC over voltage	X	X		
8	DC under voltage	X	X		
9	Inverter overloaded	X	X		
10	Motor ETR over temperature	(X)	(X)		1-90
11	Motor thermistor over temperature	(X)	(X)		1-90
12	Torque limit	X	X		
13	Over Current	X	X	X	
14	Earth fault	X	X	X	
15	Incomp. HW		X	X	
16	Short Circuit		X	X	
17	Control word timeout	(X)	(X)		8-04
18	Start failed		X		
19	Discharge temp. high	X	X		
23	Internal fans				
24	External fans				
25	Brake resistor short-circuited	X			
26	Brake resistor power limit	(X)	(X)		2-13
27	Brake chopper short-circuited	X	X		
28	Brake check	(X)	(X)		2-15
29	Power board over temp	X	X	X	
30	Motor phase U missing	(X)	(X)	(X)	4-58
31	Motor phase V missing	(X)	(X)	(X)	4-58
32	Motor phase W missing	(X)	(X)	(X)	4-58
33	Inrush fault		X	X	
34	Fieldbus communication fault	X	X		
36	Mains failure				
38	Internal fault		X	X	
40	Overload T27				
41	Overload T29				
42	Overload X30/6-7				
47	24 V supply low	X	X	X	
48	1.8 V supply low		X	X	
49	Speed limit	X	X		
50	AMA calibration failed		X		
51	AMA check U_{nom} and I_{nom}		X		
52	AMA low I_{nom}		X		
53	AMA motor too big		X		
54	AMA motor too small		X		
55	AMA parameter out of range		X		
56	AMA interrupted by user		X		
57	AMA timeout		X		
58	AMA internal fault	X	X		
59	Current limit	X			
60	External interlock				
62	Output Frequency at Maximum Limit	X			
64	Voltage Limit	X			
65	Control Board Over-temperature	X	X	X	
66	Heat sink Temperature Low	X			
67	Option Configuration has Changed		X		
68	Safe Stop Activated		X		

Table 8.1 Alarm/Warning code list

No.	Description	Warning	Alarm/Trip	Alarm/Trip Lock	Parameter Reference
70	Illegal FC configuration				
80	Drive Initialised to Default Value		X		
92	No-Flow	X	X		22-2*
93	Dry Pump	X	X		22-2*
94	End of Curve	X	X		22-5*
95	Broken Belt	X	X		22-6*
96	Start Delayed	X			22-7*
97	Stop Delayed	X			22-7*
98	Clock Fault	X			0-7*
219	Compressor Interlock	X			
250	New spare part				
251	New type code				

Table 8.2 Alarm/Warning code list, continued..

(X) Dependent on parameter

LED indication	
Warning	yellow
Alarm	flashing red
Trip locked	yellow and red

Alarm Word and Extended Status Word					
Bit	Hex	Dec	Alarm Word	Warning Word	Extended Status Word
0	00000001	1	Brake Check	Brake Check	Ramping
1	00000002	2	Pwr. Card Temp	Pwr. Card Temp	AMA Running
2	00000004	4	Earth Fault	Earth Fault	Start CW/CCW
3	00000008	8	Ctrl.Card Temp	Ctrl.Card Temp	Slow Down
4	00000010	16	Ctrl. Word TO	Ctrl. Word TO	Catch Up
5	00000020	32	Over Current	Over Current	Feedback High
6	00000040	64	Torque Limit	Torque Limit	Feedback Low
7	00000080	128	Motor Th Over	Motor Th Over	Output Current High
8	00000100	256	Motor ETR Over	Motor ETR Over	Output Current Low
9	00000200	512	Inverter Overld.	Inverter Overld.	Output Freq High
10	00000400	1024	DC under Volt	DC under Volt	Output Freq Low
11	00000800	2048	DC over Volt	DC over Volt	Brake Check OK
12	00001000	4096	Short Circuit	DC Voltage Low	Braking Max
13	00002000	8192	Inrush Fault	DC Voltage High	Braking
14	00004000	16384	Mains ph. Loss	Mains ph. Loss	Out of Speed Range
15	00008000	32768	AMA Not OK	No Motor	OVC Active
16	00010000	65536	Live Zero Error	Live Zero Error	
17	00020000	131072	Internal Fault	10V Low	
18	00040000	262144	Brake Overload	Brake Overload	
19	00080000	524288	U phase Loss	Brake Resistor	
20	00100000	1048576	V phase Loss	Brake IGBT	
21	00200000	2097152	W phase Loss	Speed Limit	
22	00400000	4194304	Fieldbus Fault	Fieldbus Fault	
23	00800000	8388608	24 V Supply Low	24V Supply Low	
24	01000000	16777216	Mains Failure	Mains Failure	
25	02000000	33554432	1.8V Supply Low	Current Limit	
26	04000000	67108864	Brake Resistor	Low Temp	
27	08000000	134217728	Brake IGBT	Voltage Limit	
28	10000000	268435456	Option Change	Unused	
29	20000000	536870912	Drive Initialised	Unused	
30	40000000	1073741824	Safe Stop	Unused	

Table 8.3 Description of Alarm Word, Warning Word and Extended Status Word

The alarm words, warning words and extended status words can be read out via serial bus or optional fieldbus for diagnosis. See also par. 16-90, 16-92 and 16-94.

Description of Alarm Word 2 and Warning Word 2				
Bit	Hex	Dec	Alarm Word 2	Warning Word 2
0	00000001	1		Start Delayed
1	00000002	2		Stop Delayed
9	00000200	512	Discharge Temperature High	Discharge Temperature High
10	00000400	1024	Start Limit	
11	00000800	2048	Speed Limit	

Table 8.4 Compressor specific Alarms and Warnings

8.1.1 Warning/Alarm list

WARNING 1, 10 Volts low:

The 10 V voltage from terminal 50 on the control card is below 10 V.

Remove some of the load from terminal 50, as the 10 V supply is overloaded. Max. 15 mA or minimum 590 ohm.

WARNING/ALARM 2, Live zero error:

The signal on terminal 53 or 54 is less than 50% of the value set in par. 6-10, par. 6-12, par. 6-20, or par. 6-22 respectively.

WARNING/ALARM 3, No motor:

No motor has been connected to the output of the frequency converter.

WARNING/ALARM 4, Mains phase loss:

A phase is missing on the supply side, or the mains voltage imbalance is too high. This message also appears in case of a fault in the input rectifier on the frequency converter. Check the supply voltage and supply currents to the frequency converter.

WARNING 5, DC link voltage high:

The intermediate circuit voltage (DC) is higher than the overvoltage limit of the control system. The frequency converter is still active.

WARNING 6, DC link voltage low

The intermediate circuit voltage (DC) is below the undervoltage limit of the control system. The frequency converter is still active.

WARNING/ALARM 7, DC over voltage:

If the intermediate circuit voltage exceeds the limit, the frequency converter trips after a time. Connect a brake resistor. Extend the ramp time

Possible corrections:

- Connect a brake resistor
- Extend the ramp time
- Activate functions in par. 2-10
- Increase par. 14-26

Alarm/warning limits:		
Voltage ranges	3 x 200 - 240 V	3 x 380 - 480 V
	[VDC]	[VDC]
Undervoltage	185	373
Voltage warning low	205	410
Voltage warning high (w/o brake - w/brake)	390/405	810/840
Overvoltage	410	855
The voltages stated are the intermediate circuit voltage of the frequency converter with a tolerance of ± 5 %. The corresponding mains voltage is the intermediate circuit voltage (DC-link) divided by 1.35		

WARNING/ALARM 8, DC under voltage:

If the intermediate circuit voltage (DC) drops below the “voltage warning low” limit (see table above), the frequency converter checks if 24 V backup supply is connected.

If no 24 V backup supply is connected, the frequency converter trips after a given time depending on the unit. To check whether the supply voltage matches the frequency converter, see *Specifications*.

WARNING/ALARM 9, Inverter overloaded:

The frequency converter is about to cut out because of an overload (too high current for too long). The counter for electronic, thermal inverter protection gives a warning at 98% and trips at 100%, while giving an alarm. Reset cannot be performed before counter is below 90%. The fault is that the frequency converter is overloaded by more than 100% for too long.

WARNING/ALARM 10, Motor ETR over temperature:

According to the electronic thermal protection (ETR), the motor is too hot. It can be chosen if the frequency converter is to give a warning or an alarm when the counter reaches 100% in par. 1-90. The fault is that the motor is overloaded by more than 100% for too long. Check that the motor par. 1-24 is set correctly.

WARNING/ALARM 11, Motor thermistor over temp:

The thermistor or the thermistor connection is disconnected. Choose if the frequency converter is to give a warning or an alarm when the counter reaches 100% in par. 1-90. Check that the thermistor is connected correctly between terminal 53 or 54 (analog voltage input) and terminal 50 (+ 10 Volts supply), or between terminal 18 or 19 (digital input PNP only) and terminal 50. If a KTY sensor is used, check for correct connection between terminal 54 and 55.

WARNING/ALARM 12, Torque limit:

The torque is higher than the value in par. 4-16 (in motor operation) or the torque is higher than the value in par. 4-17 (in regenerative operation).

WARNING/ALARM 13, Over Current:

The inverter peak current limit (approx. 200% of the rated current) is exceeded. The warning will last approx. 8-12 sec., then the frequency converter trips and issues an alarm. Turn off the frequency converter and check if the motor shaft can be turned and if the motor size matches the frequency converter.

ALARM 14, Earth fault:

There is a discharge from the output phases to earth, either in the cable between the frequency converter and the motor or in the motor itself.

Turn off the frequency converter and remove the earth fault.

ALARM 15, In-complete hardware:

A fitted option is not handled by the present control board (hardware or software).

ALARM 16, Short-circuit:

There is short-circuiting in the motor or on the motor terminals.

Turn off the frequency converter and remove the short-circuit.

WARNING/ALARM 17, Control word timeout:

There is no communication to the frequency converter. The warning will only be active when par. 8-04 is NOT set to OFF.

If par. 8-04 is set to *Stop* and *Trip*, a warning appears and the frequency converter ramps down until it trips, while giving an alarm.

par. 8-03 Control word Timeout Time could possibly be increased.

Alarm 18, Start Failed

The speed has not been able to exceed Max Start Speed (par. 1-77) during the start within the allowed time (par. 1-79). This may be caused by a blocked rotor.

Warning/ Alarm 19, Discharge Temperature High

Warning:

The discharge temperature exceeds the level programmed in par. 28-24. If so programmed in par. 28-25 the drive lowers the speed of the compressor in an attempt to lower the discharge temperature.

Alarm:

The discharge temperature exceeds the level programmed in par. 28-26.

WARNING 25, Brake resistor short-circuited:

The brake resistor is monitored during operation. If it short-circuits, the brake function is disconnected and the warning appears. The frequency converter still works, but without the brake function. Turn off the frequency converter and replace the brake resistor (see par. 2-15 Brake Check).

ALARM/WARNING 26, Brake resistor power limit:

The power transmitted to the brake resistor is calculated as a percentage, as a mean value over the last 120 s, on the basis of the resistance value of the brake resistor (par. 2-11) and the intermediate circuit voltage. The warning is active when the dissipated braking power is higher than 90%. If *Trip* [2] has been selected in par. 2-13, the frequency converter cuts out and issues this alarm, when the dissipated braking power is higher than 100%.

WARNING 27, Brake chopper fault:

The brake transistor is monitored during operation and if it short-circuits, the brake function disconnects and the warning comes up. The frequency converter is still able to run, but since the brake transistor has short-circuited, substantial power is transmitted to the brake resistor, even if it is inactive. Turn off the frequency converter and remove the brake resistor.



Warning: There is a risk of substantial power being transmitted to the brake resistor if the brake transistor is short-circuited.

ALARM/WARNING 28, Brake check failed:

Brake resistor fault: the brake resistor is not connected/working.

ALARM 29, Frequency converter over temperature:

If the enclosure is IP 20 or IP 21/TYP 1, the cut-out temperature of the heat-sink is 95 °C \pm 5 °C, dependent on size of frequency converter. The temperature fault cannot be reset, until the temperature of the heatsink is below 70 °C \pm 5 °C.

The fault could be:

- Ambient temperature too high
- Too long motor cable

ALARM 30, Motor phase U missing:

Motor phase U between the frequency converter and the motor is missing.

Turn off the frequency converter and check motor phase U.

ALARM 31, Motor phase V missing:

Motor phase V between the frequency converter and the motor is missing.

Turn off the frequency converter and check motor phase V.

ALARM 32, Motor phase W missing:

Motor phase W between the frequency converter and the motor is missing.

Turn off the frequency converter and check motor phase W.

ALARM 33, Inrush fault:

Too many power-ups have occurred within a short time period. See the chapter *Specifications* for the allowed number of powerups within one minute.

WARNING/ALARM 34, Fieldbus communication fault:

The fieldbus on the communication option card is not working.

WARNING 35, Out of frequency range:

This warning is active if the output frequency has reached par. 4-52 Warning speed low or par. 4-53 Warning speed high. If the frequency converter is set to *closed loop* [3] in par. 1-00 *Configuration Mode*, the warning is active in the display. If the frequency converter is not in this mode bit 008000 Out of *frequency range* in extended status word is active but there is no warning in the display.

ALARM 38, Internal fault:

Contact the local Danfoss supplier.

WARNING 47, 24 V supply low:

The external 24 V DC backup power supply may be overloaded, otherwise contact the local Danfoss supplier.

WARNING 48, 1.8 V supply low:

Contact the local Danfoss supplier.

ALARM 49, Speed Limit:

When the speed is not within the specified range in par. 4-11 and par. 4-13. the drive will show a warning. When the speed is below the specified limit in par. 1-86 (except when starting or stopping) the drive will trip.

ALARM 50, AMA calibration failed:

Contact the local Danfoss supplier.

ALARM 51, AMA check Unom and Inom:

The setting of motor voltage, motor current, and motor power is presumably wrong. Check the settings.

ALARM 52, AMA low Inom:

The motor current is too low. Check the settings.

ALARM 53, AMA motor too big:

The motor is too big for the AMA to be carried out.

ALARM 54, AMA motor too small:

The motor is too small for the AMA to be carried out.

ALARM 55, AMA par. out of range:

The par. values found from the motor are outside acceptable range.

ALARM 56, AMA interrupted by user:

The AMA has been interrupted by the user.

ALARM 57, AMA timeout:

Try to start the AMA again a number of times, until the AMA is carried out. Please note that repeated runs may heat the motor to a level where the resistance R_s and R_r are increased. In most cases, however, this is not critical.

ALARM 58, AMA internal fault:

Contact the local Danfoss supplier.

WARNING 59, Current limit:

The current is higher than the value in par. 4-18 *Current Limit*

WARNING 60, External interlock:

External interlock has been activated. To resume normal operation, apply 24 V DC to the terminal programmed for external interlock and reset the frequency converter (via serial communication, digital I/O, or by pressing reset button on keypad).

WARNING 62, Output Frequency at Maximum Limit:

The output frequency is higher than the value set in par. 4-19

WARNING 64, Voltage Limit:

The load and speed combination demands a motor voltage higher than the actual DC link voltage.

WARNING/ALARM/TRIP 65, Control Card Over Temperature:

Control card over temperature: The cut-out temperature of the control card is 80° C.

WARNING 66, Heatsink Temperature Low:

The heat sink temperature is measured as 0° C. This could indicate that the temperature sensor is defective and thus the fan speed is increased to the maximum in case the power part or control card is very hot.

ALARM 67, Option Configuration has Changed:

One or more options has either been added or removed since the last power-down.

ALARM 68, Safe Stop Activated:

Safe Stop has been activated. To resume normal operation, apply 24 V DC to terminal 37, then send a reset signal (via Bus, Digital I/O, or by pressing [RESET]). For correct and safe use of the Safe Stop function follow the related information and instructions in the Design Guide

ALARM 70, Illegal Frequency Configuration:

Actual combination of control board and power board is illegal.

ALARM 80, Initialization to Default Value:

Parameter settings are initialised to default setting after a manual (three-finger) reset.

Warning 96, Start Delayed:

A start signal is suppressed because the time that has passed since last accepted start is less than the minimum time programmed in par. 22-76.

Warning 97, Stop Delayed:

A stop signal is suppressed because the motor has been running less time than the minimum time programmed in par. 22-77.

Warning 219, Compressor Interlock:

At least one compressor is inversely interlocked via a digital input. The interlocked compressors can be viewed in par. 25-87.

ALARM 250, New Spare Part:

The power or Switch Mode Power Supply has been exchanged. The frequency converter type code must be restored in the EEPROM. Select the correct type code in Par 14-23 according to the label on unit. Remember to select 'Save to EEPROM' to complete.

ALARM 251, New Type Code:

The frequency converter has got a new type code.

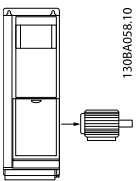
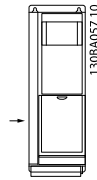

9 Specifications

9.1 General Specifications

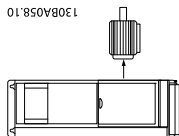
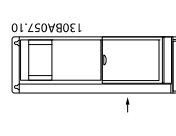
Mains supply 200 - 240 VAC - Normal overload 110% for 1 minute						
Frequency converter	P1K1	P1K5	P2K2	P3K0	P3K7	
Typical Shaft Output [kW]	1.1	1.5	2.2	3	3.7	
IP 20 / Chassis	A2	A2	A2	A3	A3	
IP 21 / NEMA 1	A2	A2	A2	A3	A3	
IP 55 / NEMA 12	A5	A5	A5	A5	A5	
IP 66 / NEMA 12	A4/A5	A4/A5	A4/A5	A5	A5	
Typical Shaft Output [HP] at 208 V	1.5	2.0	2.9	4.0	4.9	
Output current						
	Continuous (3 x 200-240 V) [A]	6.6	7.5	10.6	12.5	16.7
	Intermittent (3 x 200-240 V) [A]	7.3	8.3	11.7	13.8	18.4
	Continuous kVA (208 V AC) [kVA]	2.38	2.70	3.82	4.50	6.00
	Max. cable size: (mains, motor, brake) [mm ² /AWG] ²⁾			4/10		
Max. input current						
	Continuous (3 x 200-240 V) [A]	5.9	6.8	9.5	11.3	15.0
	Intermittent (3 x 200-240 V) [A]	6.5	7.5	10.5	12.4	16.5
	Max. pre-fuses ¹⁾ [A]	20	20	20	32	32
	Environment					
	Estimated power loss at rated max. load [W] ⁴⁾	63	82	116	155	185
	Weight enclosure IP20 [kg]	4.9	4.9	4.9	6.6	6.6
	Weight enclosure IP21 [kg]	5.5	5.5	5.5	7.5	7.5
	Weight enclosure IP55 [kg]	13.5	13.5	13.5	13.5	13.5
	Weight enclosure IP 66 [kg]	13.5	13.5	13.5	13.5	13.5
	Efficiency ³⁾	0.96	0.96	0.96	0.96	0.96

Mains supply 3 x 200 - 240 VAC - Normal overload 110% for 1 minute													
IP 20 / Chassis (B3+4 and C3+4 may be converted to IP21 using a conversion kit (Please contact Danfoss))													
IP 21 / NEMA 1													
IP 55 / NEMA 12													
IP 66 / NEMA 12													
Frequency converter													
Typical Shaft Output [kW]													
	B3	B3	B3	B3	B3	B4	B4	B4	B4	C3	C3	C4	C4
	5.5	7.5	11	15	20	25	30	40	50	60			
	P5K5	P7K5	P11K	P15K	P18K	P22K	P30K	P37K	P45K				
	5.5	7.5	11	15	20	25	30	40	50	60			
Typical Shaft Output [HP] at 208 V													
	7.5	10	15	20	25	30	40	50	60				
Output current													
 <p>130BA058.10</p>	Continuous (3 x 200-240 V) [A]												
	Intermittent (3 x 200-240 V) [A]												
	Continuous kVA (208 V AC) [kVA]												
	Max. cable size: (mains, motor, brake) [mm ² /AWG] ²⁾												
With mains disconnect switch included:													
Max. input current													
 <p>130BA057.10</p>	Continuous (3 x 200-240 V) [A]												
	Intermittent (3 x 200-240 V) [A]												
	Max. pre-fuses ¹⁾ [A]												
	Environment:												
Estimated power loss at rated max. load [W] ⁴⁾													
Weight enclosure IP20 [kg]													
Weight enclosure IP21 [kg]													
Weight enclosure IP55 [kg]													
Weight enclosure IP 66 [kg]													
Efficiency ³⁾													
	22.0	28.0	42.0	54.0	68.0	80.0	104.0	130.0	154.0				
	24.2	30.8	46.2	59.4	74.8	88.0	114.0	143.0	169.0				
	63	63	63	80	125	125	160	200	250				
	269	310	447	602	737	845	1140	1353	1636				
	12	12	12	23.5	23.5	35	35	50	50				
	23	23	23	27	45	45	45	65	65				
	23	23	23	27	45	45	45	65	65				
	23	23	23	27	45	45	45	65	65				
	0.96	0.96	0.96	0.96	0.96	0.97	0.97	0.97	0.97				

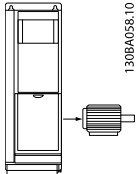
9.1.1 Mains Supply 3 x 380 - 480 VAC

Mains Supply 3 x 380 - 480 VAC - Normal overload 110% for 1 minute									
Frequency converter	P1K1	P1K5	P2K2	P3K0	P4K0	P5K5	P7K5		
Typical Shaft Output [kW]	1.1	1.5	2.2	3	4	5.5	7.5		
Typical Shaft Output [HP] at 460 V	1.5	2.0	2.9	4.0	5.3	7.5	10		
IP 20 / Chassis	A2	A2	A2	A2	A2	A3	A3		
IP 21 / NEMA 1									
IP 55 / NEMA 12	A4/A5	A4/A5	A4/A5	A4/A5	A4/A5	A5	A5		
IP 66 / NEMA 12	A4/A5	A4/A5	A4/A5	A4/A5	A4/A5	A5	A5		
Output current									
	Continuous (3 x 380-440 V) [A]	3	4.1	5.6	7.2	10	13	16	
	Intermittent (3 x 380-440 V) [A]	3.3	4.5	6.2	7.9	11	14.3	17.6	
	Continuous (3 x 440-480 V) [A]	2.7	3.4	4.8	6.3	8.2	11	14.5	
	Intermittent (3 x 440-480 V) [A]	3.0	3.7	5.3	6.9	9.0	12.1	15.4	
	Continuous kVA (400 V AC) [kVA]	2.1	2.8	3.9	5.0	6.9	9.0	11.0	
	Continuous kVA (460 V AC) [kVA]	2.4	2.7	3.8	5.0	6.5	8.8	11.6	
	Max. cable size: (mains, motor, brake) [mm ² / AWG] ²⁾								4/10
	Max. input current								
		Continuous (3 x 380-440 V) [A]	2.7	3.7	5.0	6.5	9.0	11.7	14.4
		Intermittent (3 x 380-440 V) [A]	3.0	4.1	5.5	7.2	9.9	12.9	15.8
Continuous (3 x 440-480 V) [A]		2.7	3.1	4.3	5.7	7.4	9.9	13.0	
Intermittent (3 x 440-480 V) [A]		3.0	3.4	4.7	6.3	8.1	10.9	14.3	
Max. pre-fuses ¹⁾ [A]		10	10	20	20	20	32	32	
Environment									
Estimated power loss at rated max. load [W] ⁴⁾		58	62	88	116	124	187	255	
Weight enclosure IP20 [kg]		4.8	4.9	4.9	4.9	4.9	6.6	6.6	
Weight enclosure IP21 [kg]									
Weight enclosure IP55 [kg]		13.5	13.5	13.5	13.5	13.5	14.2	14.2	
Weight enclosure IP66 [kg]	13.5	13.5	13.5	13.5	13.5	14.2	14.2		
Efficiency ³⁾	0.96	0.97	0.97	0.97	0.97	0.97	0.97		

Mains Supply 3 x 380 - 480 VAC - Normal overload 110% for 1 minute

Frequency converter Typical Shaft Output [kW]	P11K	P15K	P18K	P22K	P30K	P37K	P45K	P55K	P75K	P90K
Typical Shaft Output [HP] at 460 V	15	20	25	30	40	50	60	75	100	125
IP 20 / Chassis (B3+4 and C3+4 may be converted to IP21 using a conversion kit (Please contact Danfoss))	B3	B3	B3	B4	B4	B4	C3	C3	C4	C4
IP 21 / NEMA 1	B1	B1	B1	B2	B2	C1	C1	C1	C2	C2
IP 55 / NEMA 12	B1	B1	B1	B2	B2	C1	C1	C1	C2	C2
IP 66 / NEMA 12	B1	B1	B1	B2	B2	C1	C1	C1	C2	C2

Output current

Continuous (3 x 380-439 V) [A]	24	32	37.5	44	61	73	90	106	147	177
Intermittent (3 x 380-439 V) [A]	26.4	35.2	41.3	48.4	67.1	80.3	99	117	162	195
Continuous (3 x 440-480 V) [A]	21	27	34	40	52	65	80	105	130	160
Intermittent (3 x 440-480 V) [A]	23.1	29.7	37.4	44	61.6	71.5	88	116	143	176
Continuous kVA (400 V AC) [kVA]	16.6	22.2	26	30.5	42.3	50.6	62.4	73.4	102	123
Continuous kVA (460 V AC) [kVA]	16.7	21.5	27.1	31.9	41.4	51.8	63.7	83.7	104	128
Max. cable size: (mains, motor, brake) [mm ² / AWG] ²⁾	35/2 50/1/0 (B4=35/2) 95/4/0 120/MCM250									

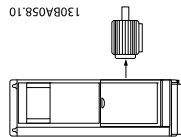

Max. input current

Continuous (3 x 380-439 V) [A]	22	29	34	40	55	66	82	96	133	161
Intermittent (3 x 380-439 V) [A]	24.2	31.9	37.4	44	60.5	72.6	90.2	106	146	177
Continuous (3 x 440-480 V) [A]	19	25	31	36	47	59	73	95	118	145
Intermittent (3 x 440-480 V) [A]	20.9	27.5	34.1	39.6	51.7	64.9	80.3	105	130	160
Max. pre-fuses ¹⁾ [A]	63	63	63	63	80	100	125	160	250	250
Environment										
Estimated power loss at rated max. load [W] ⁴⁾	278	392	465	525	698	739	843	1083	1384	1474
Weight enclosure IP 20 [kg]	12	12	12	23.5	23.5	23.5	35	35	50	50
Weight enclosure IP 21 [kg]	23	23	23	27	27	45	45	45	65	65
Weight enclosure IP 55 [kg]	23	23	23	27	27	45	45	45	65	65
Weight enclosure IP 66 [kg]	23	23	23	27	27	45	45	45	65	65
Efficiency ³⁾	0.98	0.98	0.98	0.98	0.98	0.98	0.98	0.98	0.98	0.99

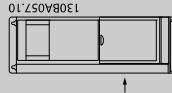

¹⁾ For type of fuse see section Fuses
²⁾ American Wire Gauge
³⁾ Measured using 5 m screened motor cables at rated load and rated frequency
⁴⁾ The typical power loss is at normal load conditions and expected to be within +/- 15% (tolerance relates to variety in voltage and cable conditions). Values are based on a typical motor efficiency (eff2/eff3 border line). Lower efficiency motors will also add to the power loss in the frequency converter and vice versa. If the switching frequency is raised from nominal the power losses may rise significantly. LCP and typical control card power consumptions are included. Further options and customer load may add up to 30W to the losses. (Though typically only 4W extra for a fully loaded control card, or options for slot A or slot B, each). Although measurements are made with state of the art equipment, some measurement inaccuracy must be allowed for (+/- 5%).

9.1.2 General specifications:

Mains supply (L1, L2, L3):

Supply voltage	380-480 V ±10%
Supply frequency	50/60 Hz ±5%
Max. imbalance temporary between mains phases	3.0 % of rated supply voltage
True Power Factor ()	≥ 0.9 nominal at rated load
Displacement Power Factor (cos) near unity	(> 0.98)
Switching on input supply L1, L2, L3 (power-ups) ≤ enclosure type A	maximum twice/min.
Switching on input supply L1, L2, L3 (power-ups) ≥ enclosure type B, C	maximum once/min.
Environment according to EN60664-1	overvoltage category III / pollution degree 2

The unit is suitable for use on a circuit capable of delivering not more than 100.000 RMS symmetrical Amperes, 480/600 V maximum.

Motor output (U, V, W):

Output voltage	0 - 100% of supply voltage
Output frequency	0 - 1000 Hz*
Switching on output	Unlimited
Ramp times	1 - 3600 sec.

* Dependent on power size.

Torque characteristics:

Starting torque (Constant torque)	maximum 110% for 1 min.*
Starting torque	maximum 135% up to 0.5 sec.*
Overload torque (Constant torque)	maximum 110% for 1 min.*

*Percentage relates to ADAP-KOOL Drive's nominal torque.

Cable lengths and cross sections:

Max. motor cable length, screened/armoured	150 m
Max. motor cable length, unscreened/unarmoured	300 m
Max. cross section to motor, mains, load sharing and brake *	
Maximum cross section to control terminals, rigid wire	1.5 mm ² /16 AWG (2 x 0.75 mm ²)
Maximum cross section to control terminals, flexible cable	1 mm ² /18 AWG
Maximum cross section to control terminals, cable with enclosed core	0.5 mm ² /20 AWG
Minimum cross section to control terminals	0.25 mm ²

* See Mains Supply tables for more information!

Digital inputs:

Programmable digital inputs	4 (6)
Terminal number	18, 19, 27 ¹⁾ , 29 ¹⁾ , 32, 33,
Logic	PNP or NPN
Voltage level	0 - 24 V DC
Voltage level, logic '0' PNP	< 5 V DC
Voltage level, logic '1' PNP	> 10 V DC
Voltage level, logic '0' NPN	> 19 V DC
Voltage level, logic '1' NPN	< 14 V DC
Maximum voltage on input	28 V DC
Input resistance, R _i	approx. 4 kΩ

All digital inputs are galvanically isolated from the supply voltage (PELV) and other high-voltage terminals.

1) Terminals 27 and 29 can also be programmed as output.

Analog inputs:

Number of analog inputs	2
Terminal number	53, 54
Modes	Voltage or current
Mode select	Switch S201 and switch S202
Voltage mode	Switch S201/switch S202 = OFF (U)
Voltage level	: 0 to + 10 V (scaleable)
Input resistance, R_i	approx. 10 k Ω
Max. voltage	\pm 20 V
Current mode	Switch S201/switch S202 = ON (I)
Current level	0/4 to 20 mA (scaleable)
Input resistance, R_i	approx. 200 Ω
Max. current	30 mA
Resolution for analog inputs	10 bit (+ sign)
Accuracy of analog inputs	Max. error 0.5% of full scale
Bandwidth	: 200 Hz

The analog inputs are galvanically isolated from the supply voltage (PELV) and other high-voltage terminals.

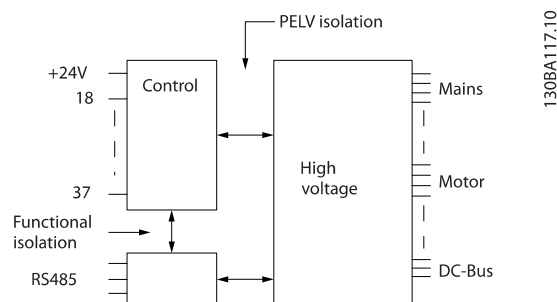
Pulse inputs:

Programmable pulse inputs	2
Terminal number pulse	29, 33
Max. frequency at terminal, 29, 33	110 kHz (Push-pull driven)
Max. frequency at terminal, 29, 33	5 kHz (open collector)
Min. frequency at terminal 29, 33	4 Hz
Voltage level	see section on Digital input
Maximum voltage on input	28 V DC
Input resistance, R_i	approx. 4 k Ω
Pulse input accuracy (0.1 - 1 kHz)	Max. error: 0.1% of full scale

Analog output:

Number of programmable analog outputs	1
Terminal number	42
Current range at analog output	0/4 - 20 mA
Max. resistor load to common at analog output	500 Ω
Accuracy on analog output	Max. error: 0.8 % of full scale
Resolution on analog output	8 bit

The analog output is galvanically isolated from the supply voltage (PELV) and other high-voltage terminals.

Control card, RS-485 serial communication:

Terminal number	68 (P,TX+, RX+), 69 (N,TX-, RX-)
Terminal number 61	Common for terminals 68 and 69

The RS-485 serial communication circuit is functionally seated from other central circuits and galvanically isolated from the supply voltage (PELV).

Digital output:

Programmable digital/pulse outputs	2
Terminal number	27, 29 ¹⁾
Voltage level at digital/frequency output	0 - 24 V
Max. output current (sink or source)	40 mA
Max. load at frequency output	1 kΩ
Max. capacitive load at frequency output	10 nF
Minimum output frequency at frequency output	0 Hz
Maximum output frequency at frequency output	32 kHz
Accuracy of frequency output	Max. error: 0.1 % of full scale
Resolution of frequency outputs	12 bit

1) Terminal 27 and 29 can also be programmed as input.

The digital output is galvanically isolated from the supply voltage (PELV) and other high-voltage terminals.

Control card, 24 V DC output:

Terminal number	12, 13
Max. load	: 200 mA

The 24 V DC supply is galvanically isolated from the supply voltage (PELV), but has the same potential as the analog and digital inputs and outputs.

Relay outputs:

Programmable relay outputs	2
Relay 01 Terminal number	1-3 (break), 1-2 (make)
Max. terminal load (AC-1) ¹⁾ on 1-3 (NC), 1-2 (NO) (Resistive load)	240 V AC, 2 A
Max. terminal load (AC-15) ¹⁾ (Inductive load @ cosφ 0.4)	240 V AC, 0.2 A
Max. terminal load (DC-1) ¹⁾ on 1-2 (NO), 1-3 (NC) (Resistive load)	60 V DC, 1 A
Max. terminal load (DC-13) ¹⁾ (Inductive load)	24 V DC, 0.1 A
Relay 02 Terminal number	4-6 (break), 4-5 (make)
Max. terminal load (AC-1) ¹⁾ on 4-5 (NO) (Resistive load) ²⁾³⁾	400 V AC, 2 A
Max. terminal load (AC-15) ¹⁾ on 4-5 (NO) (Inductive load @ cosφ 0.4)	240 V AC, 0.2 A
Max. terminal load (DC-1) ¹⁾ on 4-5 (NO) (Resistive load)	80 V DC, 2 A
Max. terminal load (DC-13) ¹⁾ on 4-5 (NO) (Inductive load)	24 V DC, 0.1 A
Max. terminal load (AC-1) ¹⁾ on 4-6 (NC) (Resistive load)	240 V AC, 2 A
Max. terminal load (AC-15) ¹⁾ on 4-6 (NC) (Inductive load @ cosφ 0.4)	240 V AC, 0.2 A
Max. terminal load (DC-1) ¹⁾ on 4-6 (NC) (Resistive load)	50 V DC, 2 A
Max. terminal load (DC-13) ¹⁾ on 4-6 (NC) (Inductive load)	24 V DC, 0.1 A
Min. terminal load on 1-3 (NC), 1-2 (NO), 4-6 (NC), 4-5 (NO)	24 V DC 10 mA, 24 V AC 20 mA
Environment according to EN 60664-1	overvoltage category III/pollution degree 2

1) IEC 60947 t 4 and 5

The relay contacts are galvanically isolated from the rest of the circuit by reinforced isolation (PELV).

2) Overvoltage Category II

3) UL applications 300 V AC 2A

Control card, 10 V DC output:

Terminal number	50
Output voltage	10.5 V ±0.5 V
Max. load	25 mA

The 10 V DC supply is galvanically isolated from the supply voltage (PELV) and other high-voltage terminals.

Control characteristics:

Resolution of output frequency at 0 - 1000 Hz	: +/- 0.003 Hz
System response time (terminals 18, 19, 27, 29, 32, 33)	: ≤ 2 ms
Speed control range (open loop)	1:100 of synchronous speed
Speed accuracy (open loop)	30 - 4000 rpm: Maximum error of ±8 rpm

All control characteristics are based on a 4-pole asynchronous motor

Surroundings:

Enclosure ≤ enclosure type D	IP 00, IP 21, IP 54
Enclosure ≥ enclosure type D, E	IP 21, IP 54
Enclosure kit available ≤ enclosure type D	IP21/NEMA 1/IP 4x on top of enclosure
Vibration test	1.0 g
Relative humidity	5% - 95%(IEC 721-3-3; Class 3K3 (non-condensing) during operation
Aggressive environment (IEC 721-3-3), uncoated	class 3C2
Aggressive environment (IEC 721-3-3), coated	class 3C3
Test method according to IEC 60068-2-43 H2S (10 days)	
Ambient temperature (at 60 AVM switching mode)	
- with derating	max. 55 ° C ¹⁾
- with full output power, typical EFF2 motors	max. 50 ° C ¹⁾
- at full continuous FC output current	max. 45 ° C ¹⁾

¹⁾ For more information on derating see the Design Guide, section on Special Conditions.

Minimum ambient temperature during full-scale operation	0 °C
Minimum ambient temperature at reduced performance	- 10 °C
Temperature during storage/transport	-25 - +65/70 °C
Maximum altitude above sea level without derating	1000 m
Maximum altitude above sea level with derating	3000 m

Derating for high altitude, see section on special conditions

EMC standards, Emission	EN 61800-3, EN 61000-6-3/4, EN 55011, IEC 61800-3 EN 61800-3, EN 61000-6-1/2,
EMC standards, Immunity	EN 61000-4-2, EN 61000-4-3, EN 61000-4-4, EN 61000-4-5, EN 61000-4-6

See section on special conditions!

Control card performance:

Scan interval	: 5 ms
Control card, USB serial communication:	
USB standard	1.1 (Full speed)
USB plug	USB type B "device" plug

WARNING

Connection to PC is carried out via a standard host/device USB cable.

The USB connection is galvanically isolated from the supply voltage (PELV) and other high-voltage terminals.

The USB connection is not galvanically isolated from protection earth. Use only isolated laptop/PC as connection to the USB connector on ADAP-KOOL Drive or an isolated USB cable/converter.

Protection and Features:

- Electronic thermal motor protection against overload.
- Temperature monitoring of the heatsink ensures that the frequency converter trips if the temperature reaches 95 °C ± 5°C. An overload temperature cannot be reset until the temperature of the heatsink is below 70 °C ± 5°C (Guideline - these temperatures may vary for different power sizes, enclosures etc.). The frequency converter has an auto derating function to avoid it's heatsink reaching 95 deg C.
- The frequency converter is protected against short-circuits on motor terminals U, V, W.
- If a mains phase is missing, the frequency converter trips or issues a warning (depending on the load).
- Monitoring of the intermediate circuit voltage ensures that the frequency converter trips if the intermediate circuit voltage is too low or too high.
- The frequency converter is protected against earth faults on motor terminals U, V, W.

9.2 Special Conditions

9.2.1 Purpose of Derating

Derating must be taken into account when using the frequency converter at low air pressure (heights), at low speeds, with long motor cables, cables with a large cross section or at high ambient temperature. The required action is described in this section.

9.2.2 Derating for Ambient Temperature

The average temperature ($T_{AMB,AVG}$) measured over 24 hours must be at least 5 °C lower than the maximum allowed ambient temperature ($T_{AMB,MAX}$).

If the frequency converter is operated at high ambient temperatures, the continuous output current should be decreased.

The derating depends on the switching pattern, which can be set to 60 AVM or SFAVM in parameter 14-00.

A enclosures

60 AVM - Pulse Width Modulation

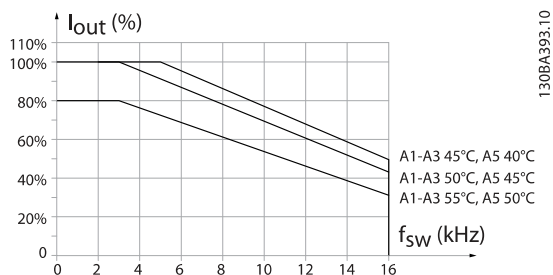

Illustration 9.1 Derating of I_{out} for different $T_{AMB,MAX}$ for enclosure A, using 60 AVM

SFAVM - Stator Frequency Asynchron Vector Modulation

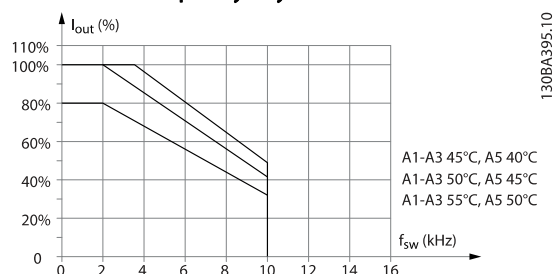

Illustration 9.2 Derating of I_{out} for different $T_{AMB,MAX}$ for enclosure A, using SFAVM

In enclosure A, the length of the motor cable has a relatively high impact on the recommended derating. Therefore, the recommended derating for an application with max. 10 m motor cable is also shown.

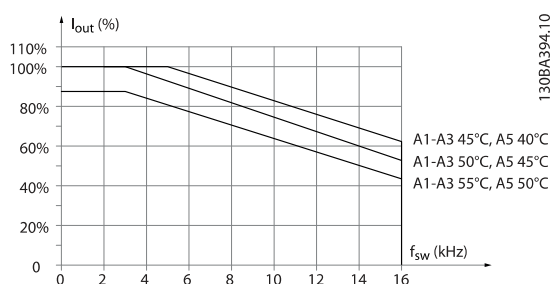

Illustration 9.3 Derating of I_{out} for different $T_{AMB,MAX}$ for enclosure A, using 60 AVM and maximum 10 m motor cable

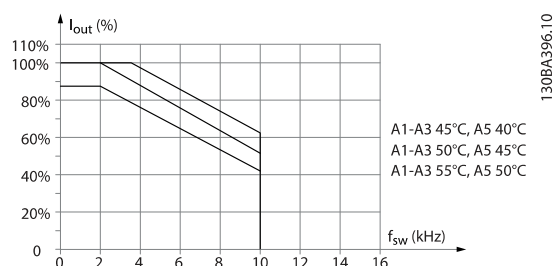

Illustration 9.4 Derating of I_{out} for different $T_{AMB,MAX}$ for enclosure A, using SFAVM and maximum 10 m motor cable

B enclosures

60 AVM - Pulse Width Modulation

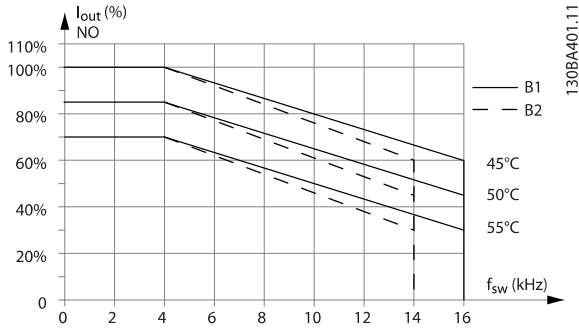

Illustration 9.5 Derating of I_{out} for different $T_{AMB, MAX}$ for enclosure B, using 60 AVM in Normal torque mode (110% over torque)

SFAVM - Stator Frequency Asynchron Vector Modulation

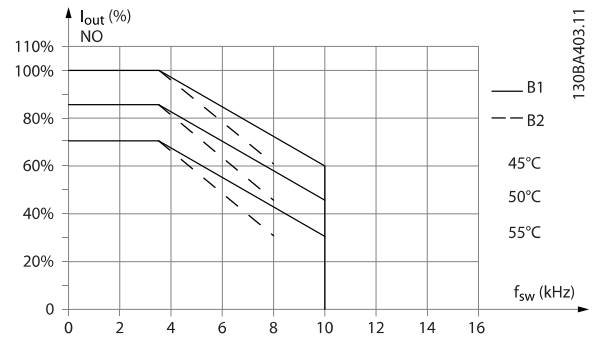

Illustration 9.6 Derating of I_{out} for different $T_{AMB, MAX}$ for enclosure B, using SFAVM in Normal torque mode (110% over torque)

Please note: For 90 kW in IP55 and IP66 the max. ambient temperature is 5° C lower.

60 AVM - Pulse Width Modulation

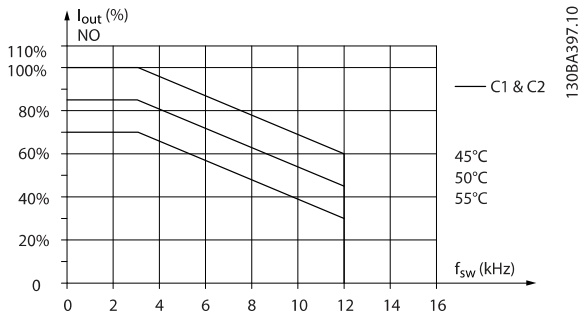

Illustration 9.7 Derating of I_{out} for different $T_{AMB, MAX}$ for enclosure C, using 60 AVM in Normal torque mode (110% over torque)

C enclosures

SFAVM - Stator Frequency Asynchron Vector Modulation

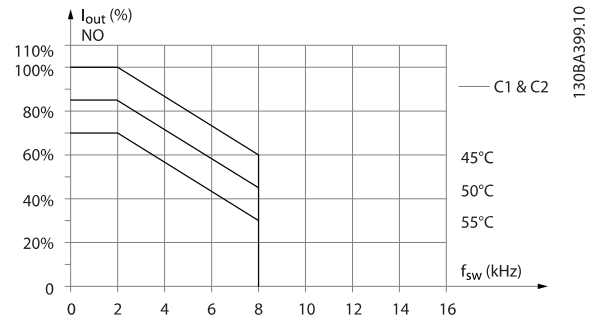

Illustration 9.8 Derating of I_{out} for different $T_{AMB, MAX}$ for enclosure C, using SFAVM in Normal torque mode (110% over torque)

9.2.3 Derating for Low Air Pressure

The cooling capability of air is decreased at lower air pressure.

At altitudes higher than 2 km, please contact Danfoss regarding PELV.

Below 1000 m altitude no derating is necessary but above 1000 m the ambient temperature (T_{AMB}) or max. output current (I_{out}) should be derated in accordance with the shown diagram.

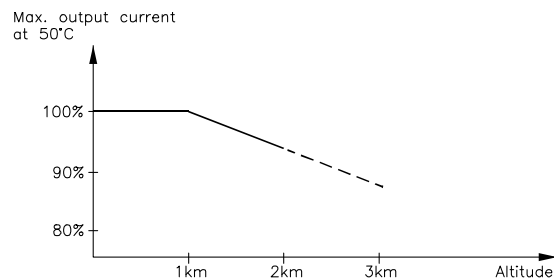

130BA040.12

Illustration 9.9 Derating of output current versus altitude at $T_{AMB, MAX}$. By altitudes above 2 km, please contact Danfoss regarding PELV.

An alternative is to lower the ambient temperature at high altitudes and thereby ensure 100% output current at high altitudes.

9.2.4 Derating for running at low speed

When a motor is connected to a frequency converter, it is necessary to check that the cooling of the motor is adequate. The level of heating depends on the load on the motor, as well as the operating speed and time.

Constant torque applications (CT mode)

A problem may occur at low RPM values in constant torque applications. In a constant torque application s a motor may over-heat at low speeds due to less cooling air from the motor integral fan.

Therefore, if the motor is to be run continuously at an RPM value lower than half of the rated value, the motor must be supplied with additional air-cooling (or a motor designed for this type of operation may be used).

An alternative is to reduce the load level of the motor by choosing a larger motor. However, the design of the frequency converter puts a limit to the motor size.

Variable (Quadratic) torque applications (VT)

In VT applications such as centrifugal pumps and fans, where the torque is proportional to the square of the speed and the power is proportional to the cube of the speed, there is no need for additional cooling or de-rating of the motor.

In the graphs shown below, the typical VT curve is below the maximum torque with de-rating and maximum torque with forced cooling at all speeds.

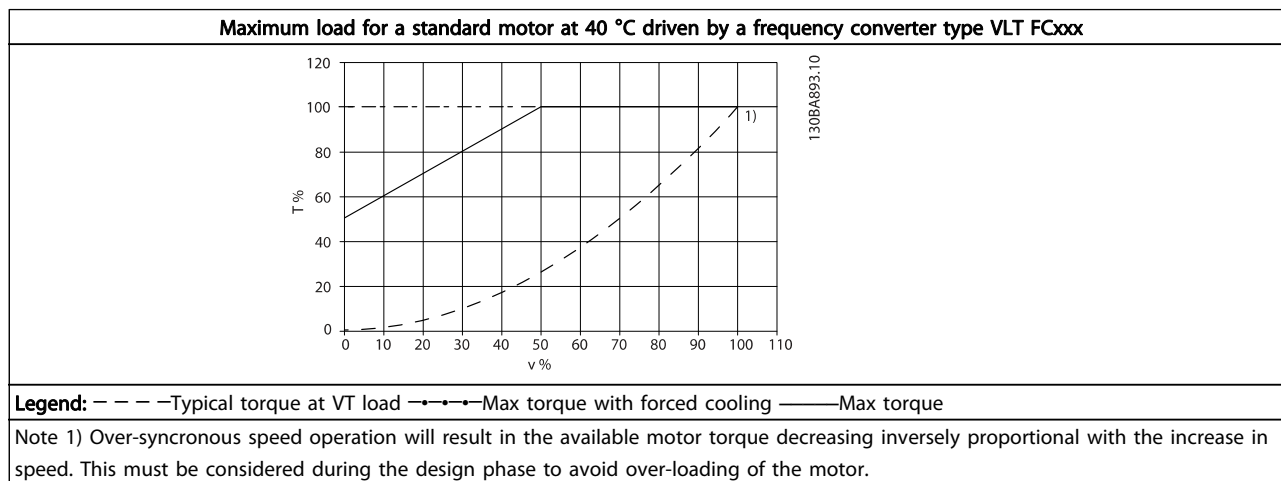

9.2.5 Derating for the installation of long motor cables or cables with larger cross-section

NOTE

Applicable for drives up to 90 kW only.

The maximum cable length for this frequency converter is 300 m unscreened and 150 m screened cable.

The frequency converter has been designed to work using a motor cable with a rated cross-section. If a cable with a larger cross-section is used, reduce the output current by 5% for every step the cross-section is increased. (Increased cable cross-section leads to increased capacity to earth, and thus an increased earth leakage current).

9.2.6 Automatic adaptations to ensure performance

The frequency converter constantly checks for critical levels of internal temperature, load current, high voltage on the intermediate circuit and low motor speeds. As a response to a critical level, the frequency converter can adjust the switching frequency and / or change the switching pattern in order to ensure the performance of the frequency converter. The capability to automatically reduce the output current extends the acceptable operating conditions even further.

Index

+

+Zone [unit], 25-21..... 77

A

Abbreviations And Standards..... 5

Acceleration Time..... 60

Access To Control Terminals..... 40

Accessory Bags..... 22

AMA..... 52

Analog

 Inputs..... 121

 Output..... 121

Auto

 Energy Optimization Compressor..... 58

 Energy Optimization VT..... 58

Automatic

 Adaptations To Ensure Performance..... 127

 Motor Adaptation (AMA)..... 43

AWG..... 116

B

Branch Circuit Protection..... 28

C

Cable Lengths And Cross Sections..... 120

Changing

 A Group Of Numeric Data Values..... 79

 A Text Value..... 79

 Data..... 78

 Of Data Value..... 79

Checklist..... 19

Coasting..... 49

Communication Option..... 114

Condenser VT..... 58

Configuration Mode, 1-00..... 69

Constant Torque Applications (CT Mode)..... 126

Control

 Cables..... 27, 26

 Card Performance..... 123

 Card, 10 V DC Output..... 122

 Card, 24 V DC Output..... 122

 Card, RS-485 Serial Communication..... 121

 Card, USB Serial Communication..... 123

 Characteristics..... 122

 Terminals..... 41

Cooling

 Cooling..... 69, 126

 Conditions..... 23

Copyright, Limitation Of Liability And Revision Rights..... 4

D

DC Link..... 112

Default Settings..... 52

Derating

 For Ambient Temperature..... 124

 For Low Air Pressure..... 125

 For Running At Low Speed..... 126

 For The Installation Of Long Motor Cables Or Cables With Larger Cross-section..... 126

Digital

 Inputs..... 120

 Output..... 122

Disposal Instruction..... 11

E

Earthing And IT Mains..... 30

Efficient Parameter Set-up For ADAP-KOOL Applications.... 57

Electrical Installation..... 26

Electronic Waste..... 11

ETR..... 112

Example Of Changing Parameter Data..... 56

F

Feedback

 1 Conversion, 20-01..... 74

 1 Source Unit, 20-02..... 74

Final Optimization And Test..... 43

Four Ways Of Operating..... 45

Frequency

 Converter..... 43

 Converter Identification..... 5

Function Setups..... 64

Fuses..... 28

G

General

 Specifications..... 120

 Warning..... 7

GLCP..... 52

Graphical Display..... 45

H

High

 Power Operating Instructions, MG.11.Ox.yy..... 25

 Power Series Mains And Motor Connections..... 25

High-voltage Warning..... 7

How

 To Connect A PC To The AKD 102..... 50

 To Connect Motor - Introduction..... 35

 To Connect To Mains And Earthing For B1 And B2..... 34

 To Operate The Graphical LCP (GLCP)..... 45

I	
Indexed Parameters.....	79
Indicator Lights.....	47
Initialisation.....	52
Installation At High Altitudes.....	8
Intermediate Circuit.....	112
Interval Between Starts, 22-76.....	76
K	
KTY Sensor.....	112
L	
Language	
Language.....	58
Package 1.....	58
LCP	
LCP.....	52
102.....	45
LEDs.....	45
Literature.....	4
M	
Main	
Menu.....	55
Menu Mode.....	48, 78
Menu Structure.....	80
Reactance.....	62
Mains	
Connection For A2 And A3.....	31
Connection For B1 And B2.....	34
Connection For C1 And C2.....	34
Supply.....	116
Wiring Overview.....	30
Mechanical	
Dimensions.....	21
Mounting.....	23
Motor	
Name Plate.....	43
Output.....	120
Protection.....	69, 123
N	
Name	
Plate Data.....	43
Plate Data.....	43
Neutral Zone [unit] , 25-20.....	77
Non UL Fuses 200 V To 480 V.....	28
O	
Output Performance (U, V, W).....	120
Over-current Protection.....	28
P	
Pack Controller, 25-00.....	77
Panel Through Mounting.....	24
Parameter	
Selection.....	78
Set-Up.....	54
PC Software Tools.....	50
Protection And Features.....	123
Pulse	
Inputs.....	121
Width Modulation.....	124
Q	
Quick	
Menu.....	47, 55
Menu Mode.....	47, 56
Transfer Of Parameter Settings When Using GLCP.....	52
R	
Reference/Feedback Unit, 20-12.....	74
Refrigerant, 20-30.....	75
Relay Outputs.....	122
RS-485 Bus Connection.....	50
S	
Safety	
Note.....	7
Regulations.....	7
Requirements Of Mechanical Installation.....	24
Screened/armoured.....	27
Serial Communication.....	123
SFAVM.....	124
Short	
Circuit Protection.....	28
Cycle Protection, 22-75.....	76
Side-by-side Installation.....	23
Sine-wave Filter.....	35
Stator	
Frequency Asynchron Vector Modulation.....	124
Leakage Reactance.....	62
Status	
Status.....	47
Messages.....	45
Step-by-Step.....	79
Surroundings.....	123
Switches S201, S202, And S801.....	43
T	
Thermistor.....	69
Tightening Of Terminals.....	25

Torque

Characteristics.....	120
Characteristics, 1-03.....	58

Type

Code String.....	6
Code String (T/C).....	5

U

UL Fuses 200 - 240 V.....	29
USB Connection.....	41

V

Variable (Quadratic) Torque Applications (VT).....	126
Voltage Level.....	120

W

Warning Against Unintended Start.....	8
Wiring Example And Testing.....	39

-

-Zone [unit], 25-22.....	77
--------------------------	----