

GE

AF-600 FP™ Fan and Pump Drive (460V/575V 150HP and above) Operating Instructions



a product of
ecomagination



imagination at work

**Contents**

1 How to Read these Operating Instructions	4
1.1.1 Copyright, Limitation of Liability and Revision Rights	4
2 Safety	6
2.1.1 High Voltage Warning	6
2.1.2 Safety Instructions	6
2.1.3 General Warning	6
2.1.4 Before Commencing Repair Work	6
2.1.5 Special Conditions	7
2.1.7 Avoid Unintended Start	7
2.1.8 IT Mains	7
3 Electrical Installation	9
3.1 Electrical Installation	9
3.1.1 Power Connections	9
3.1.2 Earthing	16
3.1.4 Drives with Factory installed A1/B1 RFI Filter Option:	16
3.1.5 Torque	16
3.1.6 Shielded Cables	16
3.1.7 Motor Cable	17
3.1.8 Load Sharing	17
3.1.9 Shielding against Electrical Noise	17
3.1.10 Mains Connection	18
3.1.11 External Fan Supply	18
3.1.13 Recommendations	19
3.1.14 CE Compliance	20
3.1.15 NEC and UL Compliance	25
3.1.16 Substitute Fuses for 240 V	31
3.1.18 Motor Bearing Currents	31
3.1.19 Control Cable Routing	31
3.1.21 Electrical Installation, Control Terminals	32
3.2 Connection Examples	34
3.2.1 Start/Stop	34
3.2.2 Pulse Start/Stop	34
3.3 Electrical Installation - additional	35
3.3.1 Electrical Installation, Control Cables	35
3.3.2 External Hand Off Auto Example	37
3.3.3 Switches S201, S202, and S801	38
3.4 Final Set-up and Test	38
3.5 Additional Connections	39



4 Mechanical Installation	40
4.1 How to Get Started	40
4.2 Pre-installation	41
4.2.1 Planning the Installation Site	41
4.2.2 Receiving the Frequency Converter	41
4.2.3 Transportation and Unpacking	41
4.2.4 Lifting	41
4.2.5 Mechanical Dimensions	42
4.2.6 Rated Power	49
4.3 Mechanical Installation	50
4.3.1 Tools Needed	50
4.3.2 General Considerations	50
4.3.3 Terminal Locations - Unit Size 4X	51
4.3.4 Terminal Locations - Unit Size 5X	53
4.3.5 Terminal Locations - Unit Sizes 6X	57
4.3.6 Cooling and Airflow	61
4.3.7 Installation on the Wall - IP21 (NEMA 1) and IP54 (NEMA 12) Units	62
4.3.8 Gland/Conduit Entry - IP21 (NEMA 1) and IP54 (NEMA12)	63
4.3.9 IP21 Drip Shield Installation (Unit Sizes 41 and 42)	64
4.4 Field Installation of Options	64
4.4.1 Installation of Top-only Duct Cooling Kit	64
4.4.2 Installation of Top and Bottom Covers	64
4.4.3 Outside Installation /NEMA 3R Kit of Industrial Enclosures	65
4.4.4 Installation of IP00 to IP20 Kits	65
4.4.5 Installation of cable clamp bracket in open chassis drives.	65
4.4.6 Installation on Pedestal	65
4.4.7 Installation of Mains Shield for Frequency Converters	66
4.4.8 Unit Size 6x USB Extension Kit	66
4.4.9 Installation of 4x or 5x Loadshare Option	66
5 How to Operate the Frequency Converter	67
5.1.2 How to operate graphical keypad	67
5.1.6 Tips and Tricks	71
6 How to Program	73
6.1 How to Program	73
6.1.2 Quick Menu Mode	76
6.1.3 Macros	78
6.2 Parameter Lists	83
6.2.1 Main Menu Structure	83



6.2.2 K-## Keypad Set-up	84
6.2.3 F-## Fundamental Parameters	86
6.2.4 E-## Digital In/Outs	87
6.2.5 C-## Frequency Control Functions	89
6.2.6 P-## Motor Data	89
6.2.7 H-## High Perf Parameters	90
6.2.8 AN-## Analog In / Out	91
6.2.9 SP-## Special Functions	92
6.2.10 O-## Options/Comms	93
6.2.11 AO-## Analog I/O Option	94
6.2.12 DN-## DevicNet	95
6.2.13 PB-## Profibus	96
6.2.14 EN-## EtherNet	97
6.2.15 BN-## BACnet	98
6.2.16 LN-## LonWorks	98
6.2.17 ID-## Drive Information	99
6.2.18 DR-## Data Readouts	100
6.2.19 LG-## Logs & I/O Opt. Status	102
6.2.20 AP-## HVAC Appl. Param.	103
6.2.21 FB-## Fire/Bypass Operation	105
6.2.22 T-## Timed Functions	106
6.2.23 CL-## PID Closed Loop	107
6.2.24 XC-## Ext. PID Closed Loop	108
6.2.25 PC-## Pump Controller	110
6.2.26 LC-## Logic Controller	112
6.2.27 B-## Braking Functions	112
7 General Specifications	113
8 Warnings and Alarms	125
8.1.1 Fault Messages	129
Index	135



1 How to Read these Operating Instructions

1.1.1 Copyright, Limitation of Liability and Revision Rights

This publication contains information proprietary to GE. By accepting and using this manual the user agrees that the information contained herein will be used solely for operating equipment from GE or equipment from other vendors provided that such equipment is intended for communication with GE equipment over a serial communication link. This publication is protected under the Copyright laws of Denmark and most other countries.

GE does not warrant that a software program produced according to the guidelines provided in this manual will function properly in every physical, hardware or software environment.

Although GE has tested and reviewed the documentation within this manual, GE makes no warranty or representation, neither expressed nor implied, with respect to this documentation, including its quality, performance, or fitness for a particular purpose.

In no event shall GE be liable for direct, indirect, special, incidental, or consequential damages arising out of the use, or the inability to use information contained in this manual, even if advised of the possibility of such damages. In particular, GE is not responsible for any costs, including but not limited to those incurred as a result of lost profits or revenue, loss or damage of equipment, loss of computer programs, loss of data, the costs to substitute these, or any claims by third parties.

GE reserves the right to revise this publication at any time and to make changes to its contents without prior notice or any obligation to notify former or present users of such revisions or changes.

It has been assumed that all devices will be sitting behind a firewall that does packet filtering and the environment has well-implemented restrictions on the software that can run inside the firewall. All nodes are assumed to be "trusted" nodes.

1.1.2 Symbols

Symbols used in this manual

NOTE

Indicates something to be noted by the reader.



Indicates a general warning.



Indicates a high-voltage warning.

★ Indicates default setting



1.1.3 Abbreviations and Standards

Abbreviations:	Terms:	SI-units:	I-P units:
a	Acceleration	m/s ²	ft/s ²
AWG	American wire gauge		
Auto Tune	Automatic Motor Tuning		
°C	Celsius		
I	Current	A	Amp
I _{LIM}	Current limit		
DCT	Drive Control Tool		
Joule	Energy	J = N·m	ft-lb, Btu
°F	Fahrenheit		
f	Frequency	Hz	Hz
kHz	Kilohertz	kHz	kHz
mA	Milliampere		
ms	Millisecond		
min	Minute		
M-TYPE	Motor Type Dependent		
Nm	Newton Metres		in-lbs
I _{M,N}	Nominal motor current		
f _{M,N}	Nominal motor frequency		
P _{M,N}	Nominal motor power		
U _{M,N}	Nominal motor voltage		
par.	Parameter		
PELV	Protective Extra Low Voltage		
Watt	Power	W	Btu/hr, hp
Pascal	Pressure	Pa = N/m ²	psi, psf, ft of water
I _{INV}	Rated Drive Output Current		
RPM	Revolutions Per Minute		
SR	Size Related		
T	Temperature	C	F
t	Time	s	s,hr
T _{LIM}	Torque limit		
U	Voltage	V	V

Table 1.1 Abbreviation and Standards table



2 Safety

2

2.1.1 High Voltage Warning

⚠️WARNING

The voltage of the frequency converter is dangerous whenever it is connected to mains. Incorrect installation of the motor or frequency converter may causedeath, serious injury or damage to the equipment. Consequently, it is essential to comply with the instructions in this manual as well as local and national rules and safety regulations.

2.1.2 Safety Instructions

CAUTION

Prior to using functions directly or indirectly influencing personal safety (e.g. Fire Mode or other functions either forcing the motor to stop or attempting to keep it functioning) a thorough risk analysis and system test must be carried through. The system tests must include testing failure modes regarding the control signalling (analog and digital signals and serial communication).

- Make sure the frequency converter is properly connected to earth.
- Do not remove mains connections, motor connections or other power connections while the frequency converter is connected to power.
- Protect users against supply voltage.
- Protect the motor against overloading according to national and local regulations.
- The earth leakage current exceeds 3.5 mA.
- The [OFF] key is not a safety switch. It does not disconnect the frequency converter from mains.

2.1.3 General Warning

⚠️WARNING

Warning:

Touching the electrical parts may be fatal - even after the equipment has been disconnected from mains.

Also make sure that other voltage inputs have been disconnected, (linkage of DC intermediate circuit), as well as the motor connection for kinetic back-up.

Before touching any potentially live parts of the frequency converter, wait at least as follows: Be aware that there may be high voltage on the DC link even when the Control Card LEDs are turned off. A red LED is mounted on a circuit board inside the drive to indicate the DC bus voltage. The red LED will stay lit until the DC link is 50 Vdc or lower.

Voltage	Power size	Min. Waiting Time
380 - 480V	150 - 350 HP	20 minutes
	450 - 1350 HP	40 minutes
525 - 600V	150 - 400 HP	20 minutes
	450 - 1350 HP	30 minutes

Be aware that there may be high voltage on the DC link even when the LEDs are turned off.

⚠️WARNING

Leakage Current

The earth leakage current from the frequency converter exceeds 3.5 mA. According to IEC 61800-5-1 a reinforced Protective Earth connection must be ensured by means of: a min. 10mm² Cu or 16mm² Al PE-wire or an additional PE wire - with the same cable cross section as the Mains wiring - must be terminated separately.

Residual Current Device

This product can cause a D.C. current in the protective conductor. Where a residual current device (RCD) is used for extra protection, only an RCD of Type B (time delayed) shall be used on the supply side of this product. Protective earthing of the frequency converter and the use of RCD's must always follow national and local regulations.

2.1.4 Before Commencing Repair Work

1. Disconnect the frequency converter from mains
2. Disconnect DC bus terminals 88 and 89
3. Wait at least the time mentioned in section General Warning above
4. Remove motor cable



2.1.5 Special Conditions

Electrical ratings:

The rating indicated on the nameplate of the frequency converter is based on a typical 3-phase mains power supply, within the specified voltage, current and temperature range, which is expected to be used in most applications.

The frequency converters also support other special applications, which affect the electrical ratings of the frequency converter.

Special conditions which affect the electrical ratings might be:

- High temperature applications which require de-rating of the electrical ratings
- Marine applications with more severe environmental conditions.

Other applications might also affect the electrical ratings.

Consult the relevant sections in this manual and in the *AF-600 FP Design Guide* for information about the electrical ratings.

Installation requirements:

The overall electrical safety of the frequency converter requires special installation considerations regarding:

- Fuses and circuit breakers for over-current and short-circuit protection
- Selection of power cables (mains, motor, brake and relay)
- Grid configuration (grounded delta transformer leg, IT,TN, etc.)
- Safety of low-voltage ports (PELV conditions)

Consult the relevant clauses in these instructions and in the *AF-600 FP Design Guide* for information about the installation requirements.

2.1.6 Installation at High Altitudes (PELV)

NOTE

Installation at high altitude:

380 - 480 V: At altitudes above 3 km, please contact GE regarding PELV.

525 - 600 V: At altitudes above 2 km, please contact GE regarding PELV.

2.1.7 Avoid Unintended Start

WARNING

While the frequency converter is connected to mains, the motor can be started/stopped using digital commands, bus commands, references or via the keypad.

- Disconnect the frequency converter from mains whenever personal safety considerations make it necessary to avoid unintended start.
- To avoid unintended start, always activate the [OFF] key before changing parameters.
- An electronic fault, temporary overload, a fault in the mains supply, or lost motor connection may cause a stopped motor to start.

2.1.8 IT Mains

WARNING





IT mains

Do not connect frequency converters with option factory installed A1/B1 RFI filters to mains supplies with a voltage between phase and earth of more than 440 V for 400 V. For 400 V IT mains and delta earth (grounded leg), mains voltage may exceed 440 V between phase and earth.

SP-50 RFI Filter can be used to disconnect the internal RFI capacitors from the RFI filter to ground.

2.1.9 Software Version and Approvals: AF-600 FP Fan & Pump Drive

AF-600 FP
Software version:2.13

    

This manual can be used with all AF-600 FP frequency converters with software version 2.13
The software version number can be seen from *ID-43 Software Version*.



2.1.10 Disposal Instruction

2

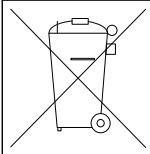

Equipment containing electrical components must not be disposed of together with domestic waste.
It must be separately collected with electrical and electronic waste according to local and currently valid legislation.

3 Electrical Installation

3.1 Electrical Installation

3.1.1 Power Connections

Cabling and Fusing

NOTE

Cables General

All cabling must comply with national and local regulations on cable cross-sections and ambient temperature. UL applications require 75 °C copper conductors. 75 and 90 °C copper conductors are thermally acceptable for the frequency converter to use in non UL applications.

The power cable connections are situated as shown below. Dimensioning of cable cross section must be done in accordance with the current ratings and local legislation. See the *Specifications* section for details.

For protection please see fuse in the tables of the fuse section. Always ensure that proper fusing is made according to local regulation.

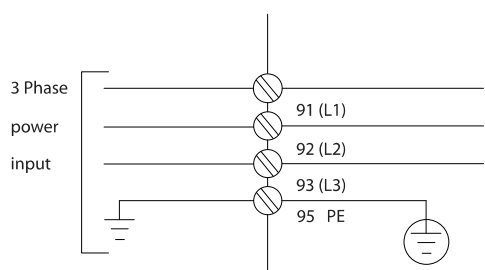

1308A026.10

NOTE

Use a screened/armoured motor cable to comply with EMC emission specifications. For more information, see *EMC specifications* in the *AF-600 FP Design Guide*.

See section 7 *General Specifications* for correct dimensioning of motor cable cross-section and length.

Screening of cables:

Avoid installation with twisted screen ends (pigtailed). They spoil the screening effect at higher frequencies. If it is necessary to break the screen to install a motor isolator or motor contactor, the screen must be continued at the lowest possible HF impedance.

Connect the motor cable screen to both the de-coupling plate of the frequency converter and to the metal housing of the motor.

Make the screen connections with the largest possible surface area (cable clamp). This is done by using the supplied installation devices within the frequency converter.

Cable-length and cross-section:

The frequency converter has been EMC tested with a given length of cable. Keep the motor cable as short as possible to reduce the noise level and leakage currents.

Switching frequency:

When frequency converters are used together with Sine-wave filters to reduce the acoustic noise from a motor, the switching frequency must be set according to the instruction in *F-26 Motor Noise (Carrier Freq)*.

Term. no.	96	97	98	99	
	U	V	W	PE ¹)	Motor voltage 0-100% of mains voltage. 3 wires out of motor
	U1	V1	W1	PE ¹)	Delta-connected 6 wires out of motor
	W2	U2	V2		
	U1	V1	W1	PE ¹)	Star-connected U2, V2, W2 U2, V2 and W2 to be interconnected separately.

1) Protected Earth Connection

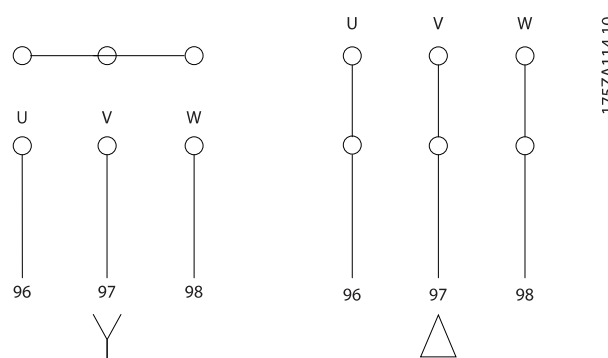

175ZA114.10



3

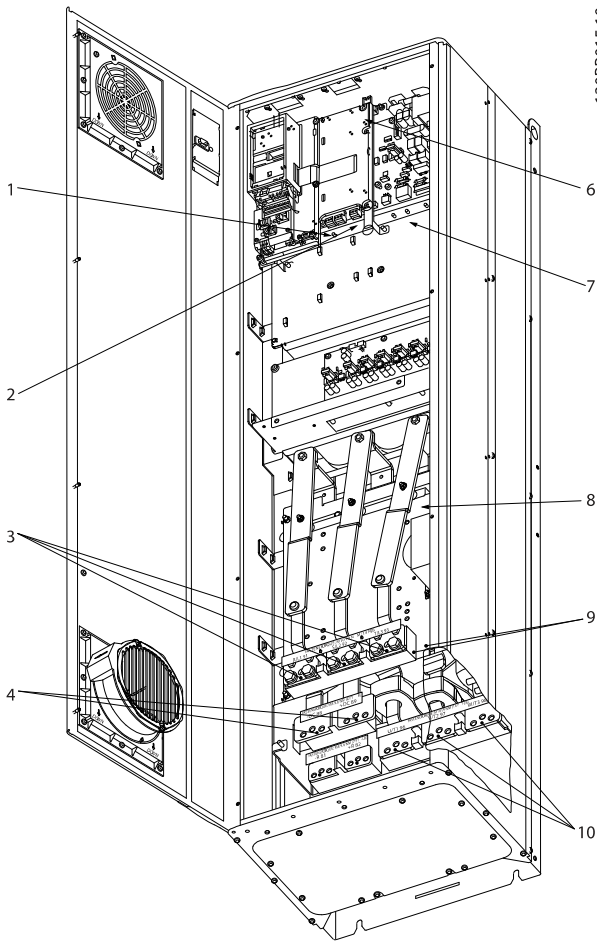

Illustration 3.1 Compact IP21 (NEMA 1) and IP54 (NEMA 12), Unit Size 41

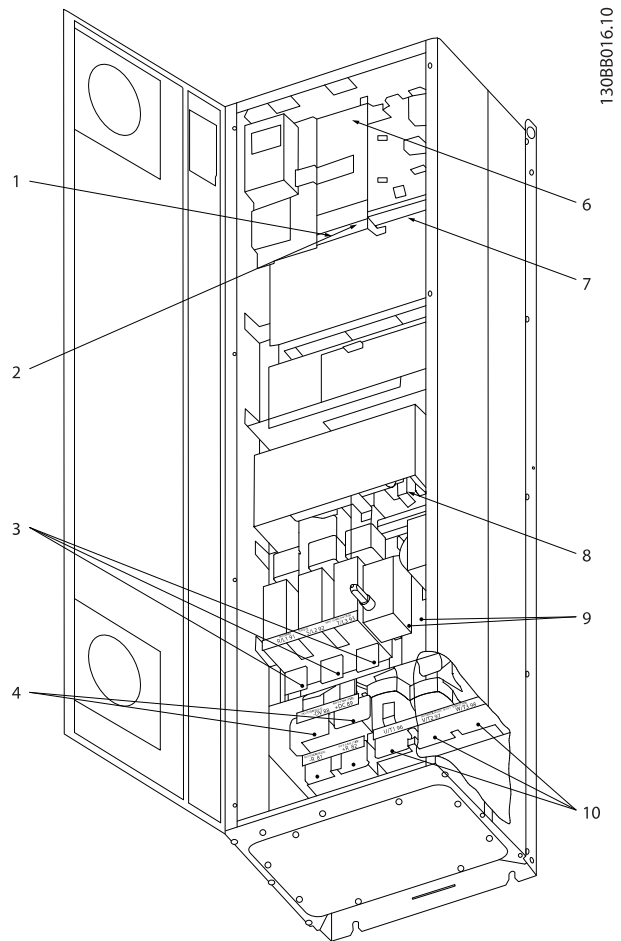
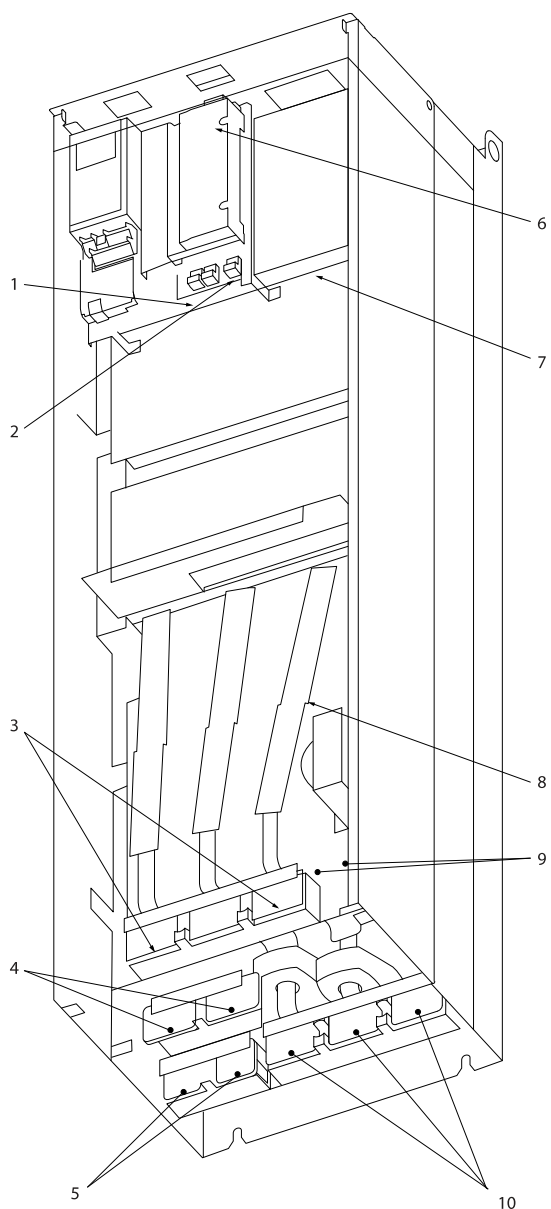

Illustration 3.2 Compact IP21 (NEMA 1) and IP54 (NEMA 12) Unit Size 42

1)	AUX Relay		
	01 02 03		
	04 05 06		
2)	Temp Switch	6)	SMPS Fuse (see fuse tables for part number)
	106 104 105	7)	AUX Fan
3)	Line		100 101 102 103
	R S T		L1 L2 L1 L2
	91 92 93	8)	Fan Fuse (see fuse tables for part number)
	L1 L2 L3	9)	Mains ground
4)	Load sharing	10)	Motor
	-DC +DC		U V W
	88 89		96 97 98
			T1 T2 T3



130BB017.10

Illustration 3.3 Compact IP00 (Chassis), Unit Size 43

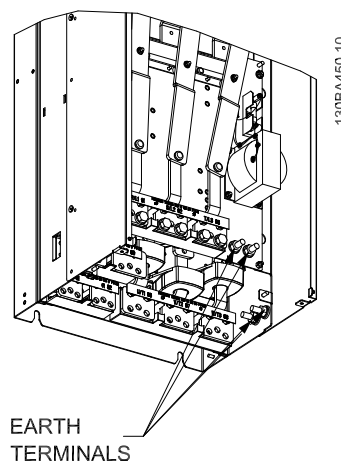

130BA450.10

EARTH
TERMINALS

Illustration 3.4 Position of earth terminals IP00 (Chassis), Unit size 44 is shown, unit size 43 is equivalent.

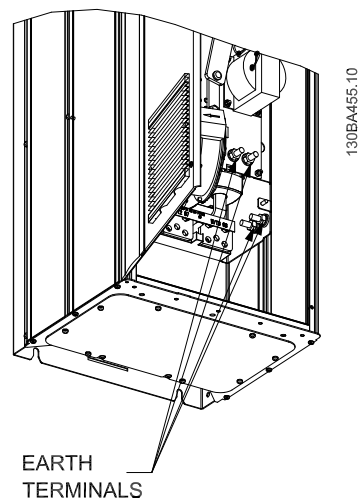

130BA455.10

EARTH
TERMINALS

Illustration 3.5 Position of earth terminals IP21 (NEMA type 1) and IP54 (NEMA type 12) Unit size 42 is shown, unit size 41 is equivalent.



3

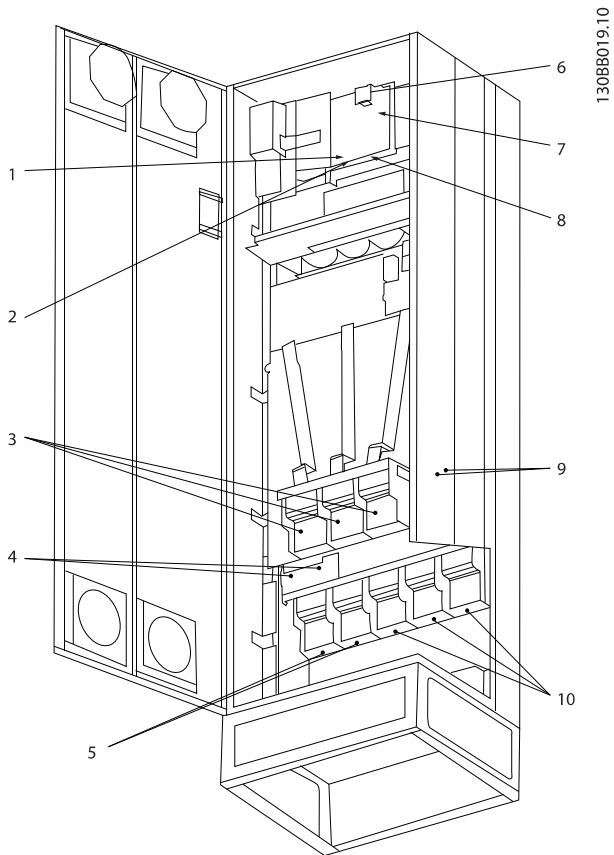

Illustration 3.6 Compact IP 21 (NEMA 1) and IP 54 (NEMA 12)
Unit Size 51

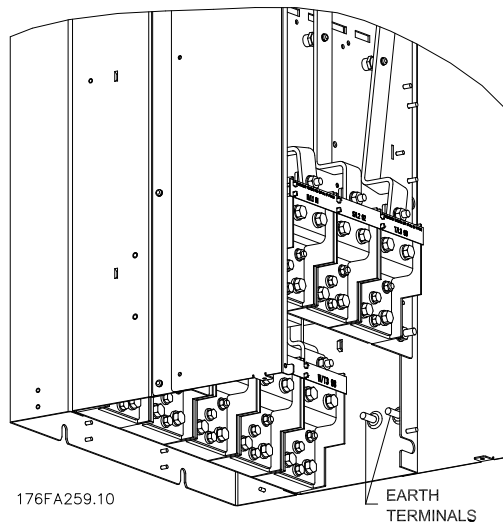

Illustration 3.7 Position of earth terminals IP00 (Chassis), Unit Size 52

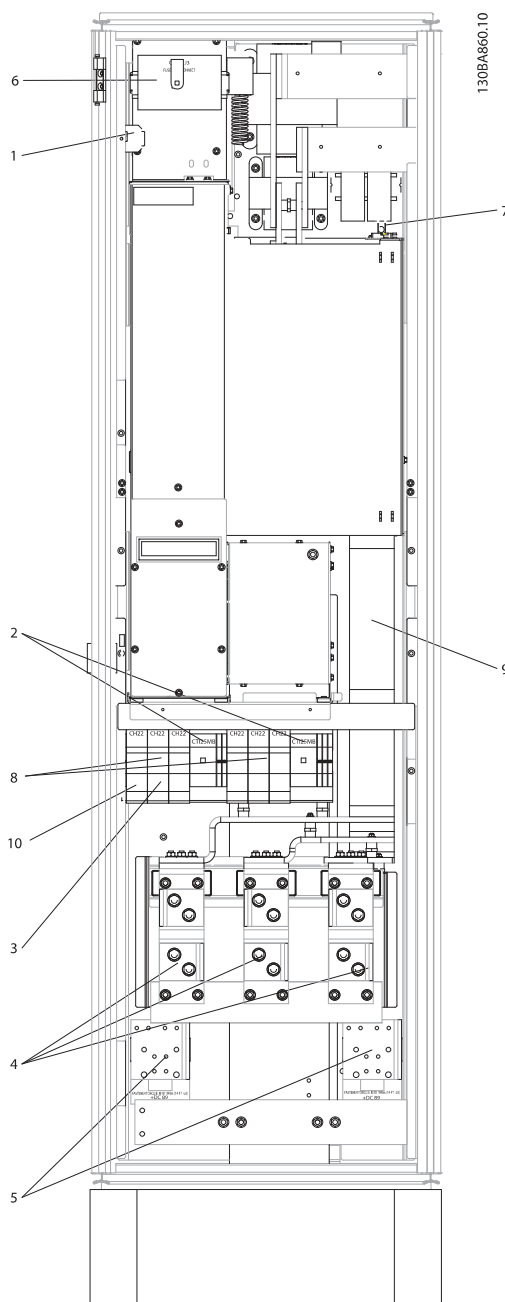

Illustration 3.8 Rectifier Cabinet, unit sizes 61, 62, 63 and 64.

1)	24V DC, 5 A	5)	Loadsharing
	T1 Output Taps		-DC +DC
	Temp Switch		88 89
	106 104 105	6)	Control Transformer Fuses (2 or 4 pieces). See fuse tables for part numbers
2)	Manual Motor Starters	7)	SMPS Fuse. See fuse tables for part numbers
3)	30 A Fuse Protected Power Terminals	8)	Manual Motor Controller fuses (3 or 6 pieces). See fuse tables for part numbers
4)	Line	9)	Line Fuses, unit sizes 61 and 62 (3 pieces). See fuse tables for part numbers
	R S T	10)	30 Amp Fuse Protected Power fuses
	L1 L2 L3		

3

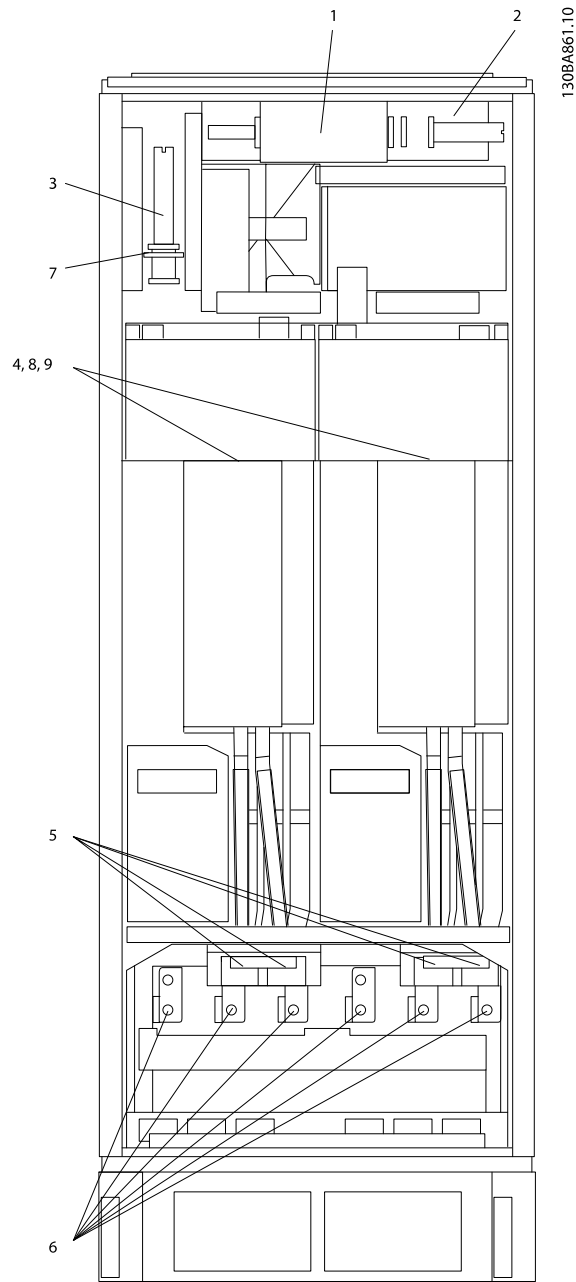
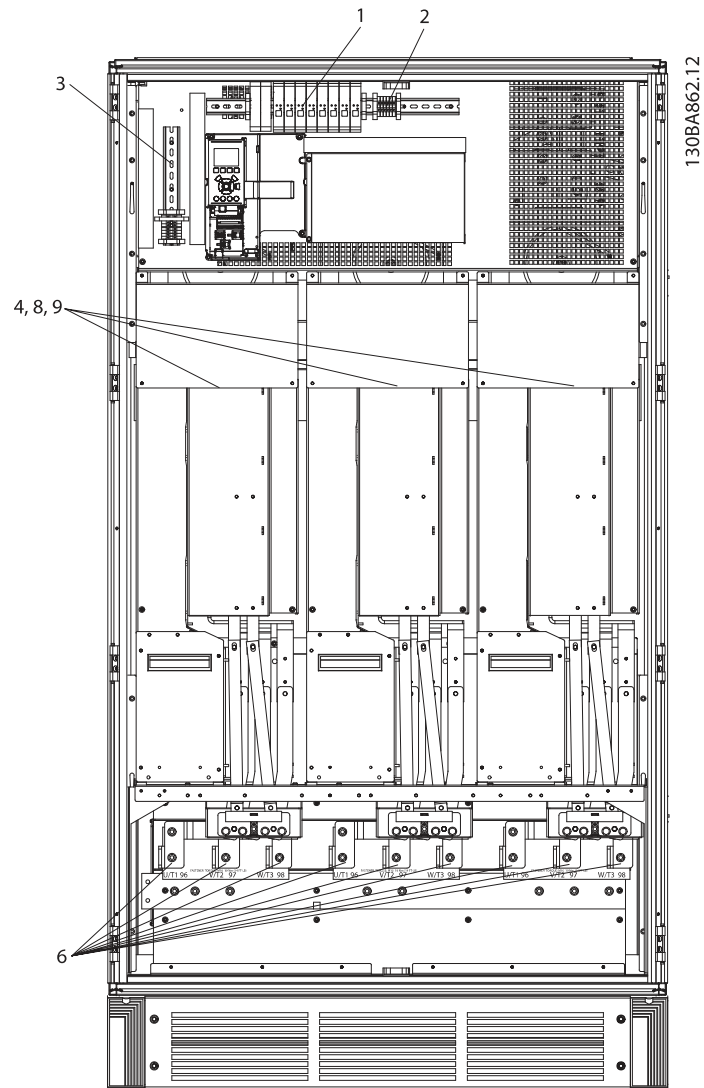

Illustration 3.9 Inverter Cabinet, unit sizes 61 and 63.

1)	External Temperature Monitoring	6)	Motor
2)	AUX Relay		U V W
	01 02 03		96 97 98
	04 05 06		T1 T2 T3
4)	AUX Fan	8)	Fan Fuses. See fuse tables for part numbers
	100 101 102 103	9)	SMPS Fuses. See fuse tables for part numbers
	L1 L2 L1 L2		



3

Illustration 3.10 Inverter Cabinet, unit sizes 62 and 64

1)	External Temperature Monitoring	6)	Motor
2)	AUX Relay		U V W
	01 02 03		96 97 98
	04 05 06		T1 T2 T3
4)	AUX Fan	8)	Fan Fuses. See fuse tables for part numbers
	100 101 102 103	9)	SMPS Fuses. See fuse tables for part numbers
	L1 L2 L1 L2		

3.1.2 Earthing

The following basic issues need to be considered when installing a frequency converter, so as to obtain electro-magnetic compatibility (EMC).

- Safety earthing: Please note that the frequency converter has a high leakage current and must be earthed appropriately for safety reasons. Apply local safety regulations.
- High-frequency earthing: Keep the earth wire connections as short as possible.

Connect the different earth systems at the lowest possible conductor impedance. The lowest possible conductor impedance is obtained by keeping the conductor as short as possible and by using the greatest possible surface area. The metal cabinets of the different devices are mounted on the cabinet rear plate using the lowest possible HF impedance. This avoids having different HF voltages for the individual devices and avoids the risk of radio interference currents running in connection cables that may be used between the devices. The radio interference will have been reduced.

In order to obtain a low HF impedance, use the fastening bolts of the devices as HF connection to the rear plate. It is necessary to remove insulating paint or similar from the fastening points.

3.1.3 Extra Protection (RCD)

ELCB relays, multiple protective earthing or earthing can be used as extra protection, provided that local safety regulations are complied with.

In the case of an earth fault, a DC component may develop in the fault current.

If ELCB relays are used, local regulations must be observed. Relays must be suitable for protection of 3-phase equipment with a bridge rectifier and for a brief discharge on power-up.

See also the section *Special Conditions* in the Design Guide.

3.1.4 Drives with Factory installed A1/B1 RFI Filter Option:

Mains supply isolated from earth

If the frequency converter is supplied from an isolated mains source (IT mains, floating delta and grounded delta) or TT/TN-S mains with grounded leg, the RFI switch is recommended to be turned off (OFF) via *SP-50 RFI Filter* on the drive and *SP-50 RFI Filter* on the filter. For further reference, see IEC 364-3. In case optimum EMC performance is needed, parallel motors are connected or the motor cable length is above 25 m, it is recommended to set *SP-50 RFI Filter* to [ON].

In OFF, the internal RFI capacities (filter capacitors) between the chassis and the intermediate circuit are cut off to avoid damage to the intermediate circuit and to reduce the earth capacity currents (according to IEC 61800-3).

It is important to use isolation monitors that are capable for use together with power electronics (IEC 61557-8).

3.1.5 Torque

When tightening all electrical connections it is very important to tighten with the correct torque. Too low or too high torque results in a bad electrical connection. Use a torque wrench to ensure correct torque

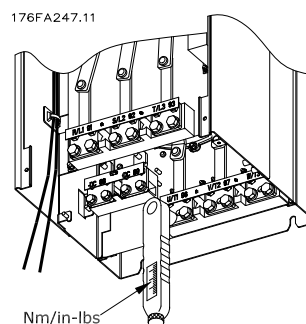

Illustration 3.11 Always use a torque wrench to tighten the bolts.

Unit Size	Terminal	Torque	Bolt size
41, 42, 43 and 44	Mains Motor	19-40 Nm (168-354 in-lbs)	M10
51 and 52	Mains Motor	19-40 Nm (168-354 in-lbs)	M10
61, 62, 63 and 64	Mains Motor	19-40 Nm (168-354 in-lbs)	M10

Table 3.1 Torque for terminals

3.1.6 Shielded Cables

It is important that shielded and armoured cables are connected in a proper way to ensure the high EMC immunity and low emissions.

The connection can be made using either cable glands or clamps:

- EMC cable glands: Generally available cable glands can be used to ensure an optimum EMC connection.
- EMC cable clamp: Clamps allowing easy connection are supplied with the frequency converter.



3.1.7 Motor Cable

The motor must be connected to terminals U/T1/96, V/T2/97, W/T3/98. Earth to terminal 99. All types of three-phase asynchronous standard motors can be used with a frequency converter unit. The factory setting is for clockwise rotation with the frequency converter output connected as follows:

Terminal No.	Function
96, 97, 98, 99	Mains U/T1, V/T2, W/T3 Earth

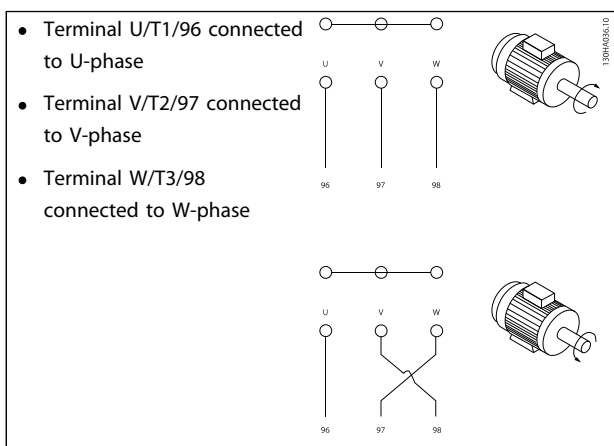

The direction of rotation can be changed by switching two phases in the motor cable or by changing the setting of *H-08 Reverse Lock* and reversing.

Unit Size 6X Requirements

Unit Size 61/63 requirements: Motor phase cable quantities must be multiples of 2, resulting in 2, 4, 6, or 8 (1 cable is not allowed) to obtain equal amount of wires attached to both inverter module terminals. The cables are required to be equal length within 10% between the inverter module terminals and the first common point of a phase. The recommended common point is the motor terminals.

Unit Size 62 and 64 requirements: Motor phase cable quantities must be multiples of 3, resulting in 3, 6, 9, or 12 (1 or 2 cables are not allowed) to obtain equal amount of wires attached to each inverter module terminal. The wires are required to be equal length within 10% between the inverter module terminals and the first common point of a phase. The recommended common point is the motor terminals.

Output junction box requirements: The length, minimum 2.5 meters, and quantity of cables must be equal from each inverter module to the common terminal in the junction box.

3.1.8 Load Sharing

Terminal No.	Function
88, 89	Loadsharing

The connection cable must be screened and the max. length from the frequency converter to the DC bar is limited to 25 metres (82 feet).

Load sharing enables linking of the DC intermediate circuits of several frequency converters.

WARNING

Please note that voltages up to 1099 VDC may occur on the terminals.

Load Sharing calls for extra equipment and safety considerations. For further information, please contact GE.

WARNING

Please note that mains disconnect may not isolate the frequency converter due to DC link connection

Please consult GE for ordering.

3.1.9 Shielding against Electrical Noise

Before mounting the mains power cable, mount the EMC metal cover to ensure best EMC performance.

NOTE: The EMC metal cover is only included in units with factory installed A1/B1 RFI Filter option..



Illustration 3.12 Mounting of EMC shield.



3.1.10 Mains Connection

Mains must be connected to terminals 91, 92 and 93. Earth is connected to the terminal to the right of terminal 93.

Terminal No.	Function
91, 92, 93	Mains R/L1, S/L2, T/L3
94	Earth

CAUTION

Check the name plate to ensure that the mains voltage of the frequency converter matches the power supply of your plant.

Ensure that the power supply can supply the necessary current to the frequency converter.

3.1.11 External Fan Supply

Unit size 4x, 5x and 6x

In case the drive is supplied by DC or if the fan must run independently of the power supply, an external power supply can be applied. The connection is made on the power card.

Terminal No.	Function
100, 101	Auxiliary supply S, T
102, 103	Internal supply S, T

The connector located on the power card provides the connection of line voltage for the cooling fans. The fans are connected from factory to be supplied from a common AC line (jumpers between 100-102 and 101-103). If external supply is needed, the jumpers are removed and the supply is connected to terminals 100 and 101. A 5 Amp fuse should be used for protection. In UL applications this should be LittleFuse KLK-5 or equivalent.



3.1.12 Fuses

It is recommended to use fuses and/ or Circuit Breakers on the supply side as protection in case of component break-down inside the drive (first fault).

NOTE

This is mandatory in order to ensure compliance with IEC 60364 for CE or NEC 2009 for UL.

⚠ WARNING

Personnel and property must be protected against the consequence of component break-down internally in the drive.

Branch Circuit Protection

In order to protect the installation against electrical and fire hazard, all branch circuits in an installation, switch gear, machines etc., must be protected against short-circuit and over-current according to national/international regulations.

NOTE

The recommendations given do not cover Branch circuit protection for UL.

Short-circuit protection:

GE recommends using the fuses/Circuit Breakers mentioned below to protect service personnel and property in case of component break-down in the drive.

Over current protection:

The drive provides overload protection to limit threats to human life, property damage and to avoid fire hazard due to overheating of the cables in the installation. The drive is equipped with an internal over current protection (*F-43 Current Limit*) that can be used for upstream overload protection (UL-applications excluded). Moreover, fuses or Circuit Breakers can be used to provide the over current protection in the installation. Over current protection must always be carried out according to national regulations.

3.1.13 Recommendations

⚠ WARNING

In case of malfunction, not following the recommendation may result in personnel risk and damage to the drive and other equipment.

The following tables list the recommended rated current. Recommended fuses are of the type gG for small to medium power sizes. For larger powers, aR fuses are recommended. Circuit breakers must be used provided they meet the national/international regulations and they limit the energy into the drive to an equal or lower level than the compliant circuit breakers.

If fuses/Circuit Breakers according to recommendations are chosen, possible damages on the drive will mainly be limited to damages inside the unit.



3.1.14 CE Compliance

Fuses or Circuit Breakers are mandatory to comply with IEC 60364. GE recommend using a selection of the following.

The fuses below are suitable for use on a circuit capable of delivering 100,000 Arms (symmetrical), 240V, or 480V, or 500V, or 600V depending on the drive voltage rating. With the proper fusing the drive short circuit current rating (SCCR) is 100,000 Arms.

3

AF-600 3-phase [HP]	Recommended fuse size	Recommended max fuse	Recommended circuit breaker	Max trip level [A]
1	gG-16	gG-25	PKZM0-25	25
2				
3				
5	gG-20	gG-32	PKZM4-50	50
7,5	gG-50	gG-63		
10				
15	gG-80	gG-125	NZMB1-A100	100
20				
25	gG-125	gG-150	NZMB2-A200	150
30				
40	aR-160	aR-160	NZMB2-A250	250
50	aR-200	aR-200		
60	aR-250	aR-250		

Table 3.2 200-240V, IP20/Open Chassis

AF-600 3-phase [HP]	Recommended fuse size	Recommended max fuse	Recommended circuit breaker	Max trip level [A]
1	gG-20	gG-32	PKZM0-25	25
2				
3				
5				
7,5	gG-63	gG-80	PKZM4-63	63
10				
15				
20	gG-80	gG-100	NZMB1-A100	100
25	gG-125	gG-160	NZMB2-A200	160
30				
40	aR-160	aR-160	NZMB2-A250	250
50	aR-200	aR-200		
60	aR-250	aR-250		

Table 3.3 200-240V, IP55/Nema 12



Electrical Installation

AF-600 FP High Power Operating Instructions

AF-600 3-phase [HP]	Recommended fuse size	Recommended max fuse	Recommended circuit breaker	Max trip level [A]
1	gG-16	gG-25	PKZM0-25	25
2				
3				
5				
7,5	gG-20	gG-32		
10				
15	gG-50	gG-63	PKZM4-50	50
20				
25				
30	gG-80	gG-125	NZMB1-A100	100
40				
50				
60	gG-125	gG-150	NZMB2-A200	150
75	aR-160	aR-160		
100	aR-250	aR-250	NZMB2-A250	250
125				
150	gG-300	gG-300		
200	gG-350	gG-350		
250	gG-400	gG-400		
300	gG-500	gG-500		
350	gG-630	gG-630		
450	aR-700	aR-700		
500	aR-900	aR-900		
550				
600				
650	aR-1600	aR-1600		
750				
900	aR-2000	aR-2000		
1000				
1200	aR-2500	aR-2500		
1350				

3

Table 3.4 380-480V, IP20/Open Chassis



Electrical Installation

AF-600 FP High Power Operating Instructions

3

AF-600 3-phase [HP]	Recommended fuse size	Recommended max fuse	Recommended circuit breaker	Max trip level [A]
1	gG-20	gG-32	PKZM0-25	25
2				
3				
5				
7,5				
10				
15	gG-50	gG-80	PKZM4-63	63
20				
25				
30	gG-80	gG-100	NZMB1-A100	100
40				
50	gG-125	gG-160	NZMB2-A200	160
60				
75				
100	aR-250	aR-250	NZMB2-A250	250
125				
150	gG-300	gG-300	-	-
200	gG-350	gG-350		
250	gG-400	gG-400		
300	gG-500	gG-500		
350	gG-630	gG-630		
450	aR-700	aR-700		
500	aR-900	aR-900		
550				
600				
650	aR-1600	aR-1600		
750				
900	aR-2000	aR-2000		
1000				
1200	aR-2500	aR-2500		
1350				

Table 3.5 380-480V, IP55/Nema 12



Electrical Installation

AF-600 FP High Power Operating Instructions

AF-600 3-phase [HP]	Recommended fuse size	Recommended max fuse	Recommended circuit breaker	Max trip level [A]
1	gG-10	gG-25	PKZM0-25	25
2				
3				
5				
7,5	gG-16	gG-32		
10				
15	gG-35	gG-63	PKZM4-50	50
20				
25				
30	gG-63	gG-125	NZMB1-A100	100
40				
50				
60	gG-100	gG-150	NZMB2-A200	150
75				
100	aR-250	aR-250	NZMB2-A250	250
125				
150	aR-315	aR-315		
200	aR-350	aR-350		
250				
300	aR-400	aR-400		
350	aR-500	aR-500		
400	aR-550	aR-550		
450	aR-700	aR-700		
500				
600	aR-900	aR-900		
650	aR-1600	aR-1600		
750				
950				
1000				
1150	aR-2000	aR-2000		
1350				

3

Table 3.6 525-600V, IP20/Open Chassis



Electrical Installation

AF-600 FP High Power Operating Instructions

3

AF-600 3-phase [HP]	Recommended fuse size	Recommended max fuse	Recommended circuit breaker	Max trip level [A]
1	gG-16	gG-32	PKZM0-25	25
2				
3				
5				
7,5				
10				
15	gG-35	gG-80	PKZM4-63	63
20				
25				
30	gG-50	gG-100	NZMB1-A100	100
40				
50	gG-125	gG-160	NZMB2-A200	160
60				
75	aR-250	aR-250	NZMB2-A250	250
100				
125	aR-315	aR-315		
150				
200				
250				
300				
350				
400				
450	aR-700	aR-700		
500				
600	aR-900	aR-900		
650				
750	aR-1600	aR-1600		
950				
1000				
1150				
1350	aR-2000	aR-2000		

Table 3.7 525-600V, IP55/Nema 12



3.1.15 NEC and UL Compliance

Fuses or Circuit Breakers are mandatory to comply with NEC 2009. We recommend using a selection of the following

The fuses below are suitable for use on a circuit capable of delivering 100,000 Arms (symmetrical), 240V, or 480V, or 600V depending on the drive voltage rating. With the proper fusing the drive Short Circuit Current Rating (SCCR) is 100,000 Arms.

Recommended max. fuse							
AF-600 1-phase Power	AF-600 3-phase Power	Bussmann	Bussmann	Bussmann	Bussmann	Bussmann	Bussmann
HP	HP	Type RK1 ¹⁾	Type J	Type T	Type CC	Type CC	Type CC
	1	KTN-R-10	JKS-10	JJN-10	FNQ-R-10	KTK-R-10	LP-CC-10
	2	KTN-R-15	JKS-15	JJN-15	FNQ-R-15	KTK-R-15	LP-CC-15
2	3	KTN-R-20	JKS-20	JJN-20	FNQ-R-20	KTK-R-20	LP-CC-20
3	5	KTN-R-30	JKS-30	JJN-30	FNQ-R-30	KTK-R-30	LP-CC-30
5	7.5-10	KTN-R-50	KS-50	JJN-50	-	-	-
7.5	15	KTN-R-60	JKS-60	JJN-60	-	-	-
10	20	KTN-R-80	JKS-80	JJN-80	-	-	-
	25-30	KTN-R-125	JKS-125	JJN-125	-	-	-
20	40	KTN-R-150	JKS-150	JJN-150	-	-	-
30	50	KTN-R-200	JKS-200	JJN-200	-	-	-
	60	KTN-R-250	JKS-250	JJN-250	-	-	-

Table 3.8 200-240V

Recommended max. fuse					
AF-600 1-phase Power	AF-600 3-phase Power	SIBA	Littel fuse	Ferraz-Shawmut	Ferraz-Shawmut
HP	HP	Type RK1	Type RK1	Type CC	Type RK1 ³⁾
	1	5017906-010	KLN-R-10	ATM-R-10	A2K-10-R
	2	5017906-016	KLN-R-15	ATM-R-15	A2K-15-R
2	3	5017906-020	KLN-R-20	ATM-R-20	A2K-20-R
3	5	5012406-032	KLN-R-30	ATM-R-30	A2K-30-R
5	7.5-10	5014006-050	KLN-R-50	-	A2K-50-R
7.5	15	5014006-063	KLN-R-60	-	A2K-60-R
10	20	5014006-080	KLN-R-80	-	A2K-80-R
	25-30	2028220-125	KLN-R-125	-	A2K-125-R
20	40	2028220-150	KLN-R-150	-	A2K-150-R
30	50	2028220-200	KLN-R-200	-	A2K-200-R
	60	2028220-250	KLN-R-250	-	A2K-250-R

Table 3.9 200-240V



Recommended max. fuse					
AF-600 1-phase	AF-600 3-phase	Bussmann	Littel fuse	Ferraz-Shawmut	Ferraz-Shawmut
HP	HP	Type JFHR2 ²⁾	Type JFHR2	Type JFHR2 ⁴⁾	Type J
	1	FWX-10	-	-	HSJ-10
	2	FWX-15	-	-	HSJ-15
2	3	FWX-20	-	-	HSJ-20
3	5	FWX-30	-	-	HSJ-30
5	7.5-10	FWX-50	-	-	HSJ-50
7.5	15	FWX-60	-	-	HSJ-60
10	20	FWX-80	-	-	HSJ-80
	25-30	FWX-125	-	-	HSJ-125
20	40	FWX-150	L25S-150	A25X-150	HSJ-150
30	50	FWX-200	L25S-200	A25X-200	HSJ-200
	60	FWX-250	L25S-250	A25X-250	HSJ-250

Table 3.10 200-240V

- 1) KTS-fuses from Bussmann may substitute KTN for 240V frequency converters.
- 2) FWH-fuses from Bussmann may substitute FWX for 240V frequency converters.
- 3) A6KR fuses from FERRAZ SHAWMUT may substitute A2KR for 240V frequency converters.
- 4) A50X fuses from FERRAZ SHAWMUT may substitute A25X for 240V frequency converters.

Recommended max. fuse							
AF-600 1-phase	AF-600 3-phase	Bussmann	Bussmann	Bussmann	Bussmann	Bussmann	Bussmann
[HP]	[HP]	Type RK1	Type J	Type T	Type CC	Type CC	Type CC
	1	KTS-R-6	JKS-6	JJS-6	FNQ-R-6	KTK-R-6	LP-CC-6
	2-3	KTS-R-10	JKS-10	JJS-10	FNQ-R-10	KTK-R-10	LP-CC-10
	5	KTS-R-20	JKS-20	JJS-20	FNQ-R-20	KTK-R-20	LP-CC-20
	7.5	KTS-R-25	JKS-25	JJS-25	FNQ-R-25	KTK-R-25	LP-CC-25
	10	KTS-R-30	JKS-30	JJS-30	FNQ-R-30	KTK-R-30	LP-CC-30
	15-20	KTS-R-40	JKS-40	JJS-40	-	-	-
	25	KTS-R-50	JKS-50	JJS-50	-	-	-
10	30	KTS-R-60	JKS-60	JJS-60	-	-	-
15	40	KTS-R-80	JKS-80	JJS-80	-	-	-
	50	KTS-R-100	JKS-100	JJS-100	-	-	-
	60	KTS-R-125	JKS-125	JJS-125	-	-	-
25	75	KTS-R-150	JKS-150	JJS-150	-	-	-
50	100	KTS-R-200	JKS-200	JJS-200	-	-	-
	125	KTS-R-250	JKS-250	JJS-250	-	-	-

Table 3.11 380-480V, 125HP and below



Recommended max. fuse					
AF-600 1-phase	AF-600 3-phase	SIBA	Littel fuse	Ferraz-Shawmut	Ferraz-Shawmut
[HP]	[HP]	Type RK1	Type RK1	Type CC	Type RK1
	1	5017906-006	KLS-R-6	ATM-R-6	A6K-10-6
	2-3	5017906-010	KLS-R-10	ATM-R-10	A6K-10-R
	5	5017906-020	KLS-R-20	ATM-R-20	A6K-20-R
	7.5	5017906-025	KLS-R-25	ATM-R-25	A6K-25-R
	10	5012406-032	KLS-R-30	ATM-R-30	A6K-30-R
	15-20	5014006-040	KLS-R-40	-	A6K-40-R
	25	5014006-050	KLS-R-50	-	A6K-50-R
10	30	5014006-063	KLS-R-60	-	A6K-60-R
15	40	2028220-100	KLS-R-80	-	A6K-80-R
	50	2028220-125	KLS-R-100	-	A6K-100-R
	60	2028220-125	KLS-R-125	-	A6K-125-R
25	75	2028220-160	KLS-R-150	-	A6K-150-R
50	100	2028220-200	KLS-R-200	-	A6K-200-R
	125	2028220-250	KLS-R-250	-	A6K-250-R

Table 3.12 380-480V, 125HP and below

Recommended max. fuse					
AF-600 1-phase	AF-600 3-phase	Bussmann	Ferraz- Shawmut	Ferraz- Shawmut	Littel fuse
[HP]	[HP]	Type JFHR2	Type J	Type JFHR2 ¹⁾	Type JFHR2
	1	FWH-6	HSJ-6	-	-
	2-3	FWH-10	HSJ-10	-	-
	5	FWH-20	HSJ-20	-	-
	7.5	FWH-25	HSJ-25	-	-
	10	FWH-30	HSJ-30	-	-
	15-20	FWH-40	HSJ-40	-	-
	25	FWH-50	HSJ-50	-	-
10	30	FWH-60	HSJ-60	-	-
15	40	FWH-80	HSJ-80	-	-
	50	FWH-100	HSJ-100	-	-
	60	FWH-125	HSJ-125	-	-
25	75	FWH-150	HSJ-150	-	-
50	100	FWH-200	HSJ-200	A50-P-225	L50-S-225
	125	FWH-250	HSJ-250	A50-P-250	L50-S-250

Table 3.13 380-480V, 125HP and below

1) Ferraz-Shawmut A50QS fuses may substitute for A50P fuses.



3

AF-600 [HP]	Recommended max. fuse					
	Bussmann Type RK1	Bussmann Type J	Bussmann Type T	Bussmann Type CC	Bussmann Type CC	Bussmann Type CC
1	KTS-R-5	JKS-5	JJS-6	FNQ-R-5	KTK-R-5	LP-CC-5
2-3	KTS-R-10	JKS-10	JJS-10	FNQ-R-10	KTK-R-10	LP-CC-10
5	KTS-R-20	JKS-20	JJS-20	FNQ-R-20	KTK-R-20	LP-CC-20
7.5	KTS-R-25	JKS-25	JJS-25	FNQ-R-25	KTK-R-25	LP-CC-25
10	KTS-R-30	JKS-30	JJS-30	FNQ-R-30	KTK-R-30	LP-CC-30
15-20	KTS-R-35	JKS-35	JJS-35	-	-	-
25	KTS-R-45	JKS-45	JJS-45	-	-	-
30	KTS-R-50	JKS-50	JJS-50	-	-	-
40	KTS-R-60	JKS-60	JJS-60	-	-	-
50	KTS-R-80	JKS-80	JJS-80	-	-	-
60	KTS-R-100	JKS-100	JJS-100	-	-	-
75	KTS-R-125	JKS-125	JJS-125	-	-	-
100	KTS-R-150	JKS-150	JJS-150	-	-	-
125	KTS-R-175	JKS-175	JJS-175	-	-	-

Table 3.14 525-600V, 125HP and below

AF-600 [HP]	Recommended max. fuse			
	SIBA Type RK1	Littel fuse Type RK1	Ferraz- Shawmut Type RK1	Ferraz- Shawmut Type J
1	5017906-005	KLS-R-005	A6K-5-R	HSJ-6
2-3	5017906-010	KLS-R-010	A6K-10-R	HSJ-10
5	5017906-020	KLS-R-020	A6K-20-R	HSJ-20
7.5	5017906-025	KLS-R-025	A6K-25-R	HSJ-25
10	5017906-030	KLS-R-030	A6K-30-R	HSJ-30
15-20	5014006-040	KLS-R-035	A6K-35-R	HSJ-35
25	5014006-050	KLS-R-045	A6K-45-R	HSJ-45
30	5014006-050	KLS-R-050	A6K-50-R	HSJ-50
40	5014006-063	KLS-R-060	A6K-60-R	HSJ-60
50	5014006-080	KLS-R-075	A6K-80-R	HSJ-80
60	5014006-100	KLS-R-100	A6K-100-R	HSJ-100
75	2028220-125	KLS-R-125	A6K-125-R	HSJ-125
100	2028220-150	KLS-R-150	A6K-150-R	HSJ-150
125	2028220-200	KLS-R-175	A6K-175-R	HSJ-175

Table 3.15 525-600V, 125HP and below

1) 170M fuses shown from Bussmann use the -/80 visual indicator. -TN/80 Type T, -/110 or TN/110 Type T indicator fuses of the same size and amperage may be substituted.



Recommended max. fuse							
AF-600	Bussmann PN	Alternate External Bussmann PN	Alternate External Bussmann PN	Alternate External Siba PN	Alternate External Littlefuse PN	Alternate External Ferraz-Shawmut PN	Alternate External Ferraz-Shawmut PN
[HP]	Type JFHR2	Type JFHR2	Type T/JDDZ	Type JFHR2	Type JFHR2	Type JFHR2	
150	170M3017	FWH-300	JJS-300	2028220-315	L50-S-300	A50-P-300	
200	170M3018	FWH-350	JJS-350	2028220-315	L50-S-350	A50-P-350	
250	170M4012	FWH-400	JJS-400	206xx32-400	L50-S-400	A50-P-400	
300	170M4014	FWH-500	JJS-500	206xx32-500	L50-S-500	A50-P-500	
350	170M4016	FWH-600	JJS-600	206xx32-600	L50-S-600	A50-P-600	
450	170M4017			20 610 32.700			6.9URD31D08A0700
500	170M6013			22 610 32.900			6.9URD33D08A0900
550	170M6013			22 610 32.900			6.9URD33D08A0900
600	170M6013			22 610 32.900			6.9URD33D08A0900
650	170M7081						
750	170M7081						
900	170M7082						
1000	170M7082						
1200	170M7083						
1350	170M7083						

Table 3.16 380-480V, above 125HP

AF-600	Bussmann PN	Rating	Alternate Siba PN
[HP]			
650	170M8611	1100A, 1000V	20 781 32.1000
750	170M8611	1100A, 1000V	20 781 32.1000
900	170M6467	1400A, 700V	20 681 32.1400
1000	170M6467	1400A, 700V	20 681 32.1400
1200	170M8611	1100A, 1000V	20 781 32.1000
1350	170M6467	1400A, 700V	20 681 32.1400

Table 3.17 380-480V, Frame Size 6, Inverter Module DC Link Fuses

3



3

AF-600	Bussmann PN	Alternate External Siba PN	Alternate External Ferraz-Shawmut PN
[HP]		Type JFHR2	Type JFHR2
150	170M3017	2061032,315	6.9URD30D08A0315
200	170M3018	2061032,35	6.9URD30D08A0350
250	170M4011	2061032,35	6.9URD30D08A0350
300	170M4012	2061032,4	6.9URD30D08A0400
350	170M4014	2061032,5	6.9URD30D08A0500
400	170M5011	2062032,55	6.9URD32D08A0550
450	170M4017	20 610 32.700	6.9URD31D08A0700
500	170M4017	20 610 32.700	6.9URD31D08A0700
600	170M6013	22 610 32.900	6.9URD33D08A0900
650	170M6013	22 610 32.900	6.9URD33D08A0900
750	170M7081		
950	170M7081		
1050	170M7081		
1150	170M7081		
1350	170M7082		
1550	170M7083		

Table 3.18 525-690V, above 125HP

AF-600	Bussmann PN	Rating	Alternate Siba PN
[HP]			
750	170M8611	1100A, 1000V	20 781 32.1000
950	170M8611	1100A, 1000V	20 781 32.1000
1050	170M8611	1100A, 1000V	20 781 32.1000
1150	170M8611	1100A, 1000V	20 781 32.1000
1350	170M8611	1100A, 1000V	20 781 32.1000
1550	170M8611	1100A, 1000V	20 781 32.1000

Table 3.19 525-690V, Frame Size 6, Inverter Module DC Link Fuses

*170M fuses from Bussmann shown use the -/80 visual indicator, -TN/80 Type T, -/110 or TN/110 Type T indicator fuses of the same size and amperage may be substituted for external use

**Any minimum 500V UL listed fuse with associated current rating may be used to meet UL requirements.

3.1.16 Substitute Fuses for 240 V

Original fuse	Manufacturer	Substitute fuses
KTN	Bussmann	KTS
FWX	Bussmann	FWH
KLNR	LITTEL FUSE	KLSR
L50S	LITTEL FUSE	L50S
A2KR	FERRAZ SHAWMUT	A6KR
A25X	FERRAZ SHAWMUT	A50X

3.1.17 Motor Insulation

For motor cable lengths \leq the maximum cable length listed in the General Specifications tables the following motor insulation ratings are recommended because the peak voltage can be up to twice the DC link voltage, 2.8 times the mains voltage, due to transmission line effects in the motor cable. If a motor has lower insulation rating it recommended to use a du/dt or sine wave filter.

Nominal Mains Voltage	Motor Insulation
$U_N \leq 420$ V	Standard $U_{LL} = 1300$ V
420 V < $U_N \leq 500$ V	Reinforced $U_{LL} = 1600$ V
500 V < $U_N \leq 600$ V	Reinforced $U_{LL} = 1800$ V
600 V < $U_N \leq 690$ V	Reinforced $U_{LL} = 2000$ V

3.1.18 Motor Bearing Currents

All motors installed with 150 HP or higher power drives should have NDE (Non-Drive End) insulated bearings installed to eliminate circulating bearing currents. To minimize DE (Drive End) bearing and shaft currents proper grounding of the drive, motor, driven machine, and motor to the driven machine is required.

Standard Mitigation Strategies:

1. Use an insulated bearing
2. Apply rigorous installation procedures
 - Ensure the motor and load motor are aligned
 - Strictly follow the EMC Installation guideline
 - Reinforce the PE so the high frequency impedance is lower in the PE than the input power leads
 - Provide a good high frequency connection between the motor and the frequency converter for instance by screened cable which has a 360° connection in the motor and the frequency converter

- Make sure that the impedance from frequency converter to building ground is lower than the grounding impedance of the machine. This can be difficult for pumps
 - Make a direct earth connection between the motor and load motor
3. Lower the IGBT switching frequency
 4. Modify the inverter waveform, 60° AVM vs. SFAVM
 5. Install a shaft grounding system or use an isolating coupling
 6. Apply conductive lubrication
 7. Use minimum speed settings if possible
 8. Try to ensure the line voltage is balanced to ground. This can be difficult for IT, TT, TN-CS or Grounded leg systems
 9. Use a dU/dt or sinus filter

3

3.1.19 Control Cable Routing

Tie down all control wires to the designated control cable routing as shown in the picture. Remember to connect the shields in a proper way to ensure optimum electrical immunity.

Field Installed Network Module options connection

Connections are made to the network options on the control card. For details see the relevant network instructions. The cable must be placed in the provided path inside the frequency converter and tied down together with other control wires (see illustrations).

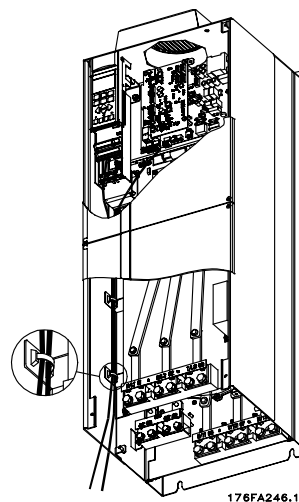

Illustration 3.13 Control card wiring path for the 43. Control card wiring for the 41, 42, 44, 51 and 52 use the same path.

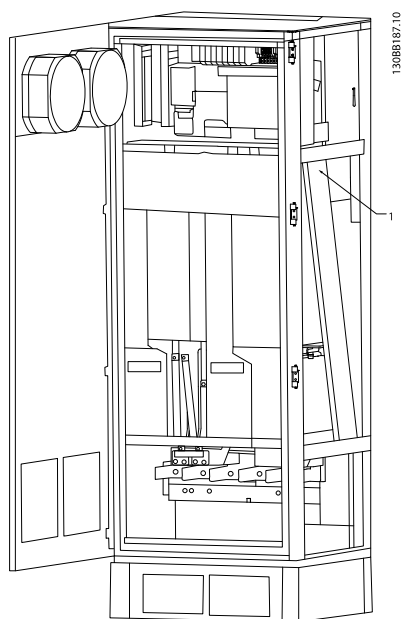

Illustration 3.14 Control card wiring path for the 61/63. Control card wiring for the 62/64 use the same path.

In the Chassis (IP00) and NEMA 1 units it is also possible to connect the network from the top of the unit as shown in the following pictures. On the NEMA 1 unit a cover plate must be removed.



Illustration 3.15 Top connection for network.

Installation of field installed 24 Volt external DC Supply option module (OPC24VPS)

Torque: 0.5 - 0.6 Nm (5 in-lbs)

Screw size: M3

No.	Function
35 (-), 36 (+)	24V external DC supply

24V DC external supply can be used as low-voltage supply to the control card and any I/O or network option cards installed. This enables full operation of the keypad (including parameter setting) without connection to mains.

Please note that a warning of low voltage will be given when 24 VDC has been connected; however, there will be no tripping.

⚠ WARNING

Use 24 VDC supply of type PELV to ensure correct galvanic isolation (type PELV) on the control terminals of the frequency converter.

3.1.20 Access to Control Terminals

All terminals to the control cables are located beneath the keypad. They are accessed by opening the door of the Nema 1 / Nema 12 or removing the covers of the IP00 Open Chassis version.

3.1.21 Electrical Installation, Control Terminals

To connect the cable to the terminal:

1. Strip insulation by about 9-10mm

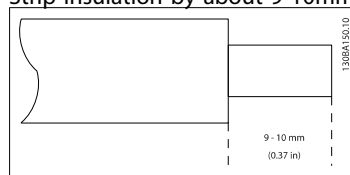

2. Insert a screwdriver¹⁾ in the square hole.
3. Insert the cable in the adjacent circular hole.

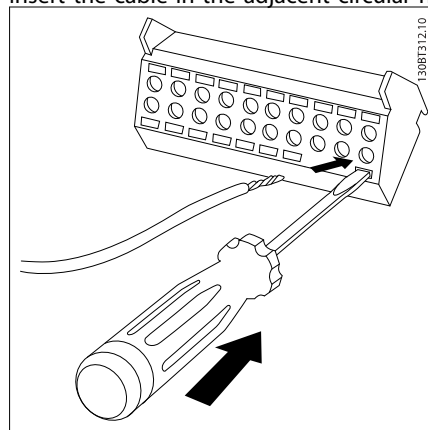

4. Remove the screwdriver. The cable is now mounted in the terminal.

To remove the cable from the terminal:

1. Insert a screw driver¹⁾ in the square hole.



2. Pull out the cable.

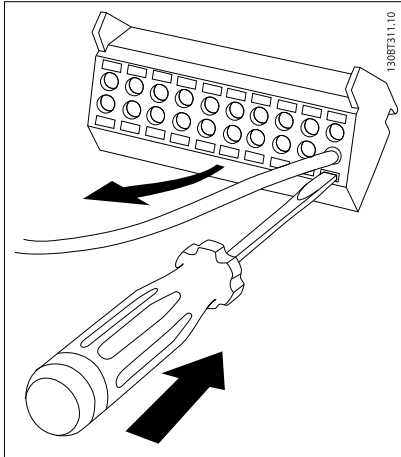

1) Max. 0.4 x 2.5mm

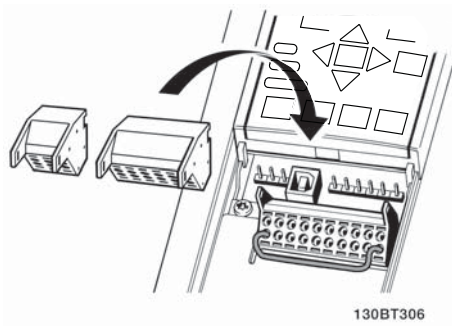



3.2 Connection Examples

3.2.1 Start/Stop

Terminal 18 = E-01 Terminal 18 Digital Input [8] Start

Terminal 27 = E-03 Terminal 27 Digital Input [0] No operation (Default coast inverse)

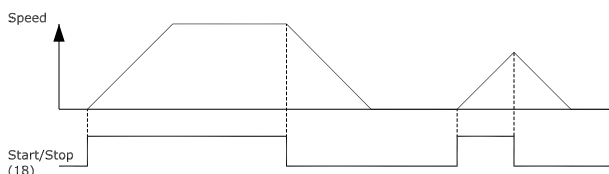
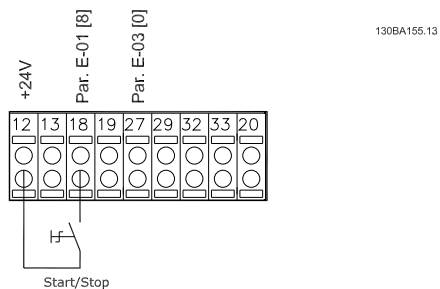

3.2.2 Pulse Start/Stop

Terminal 18 = E-01 Terminal 18 Digital Input [9] Latched start

Terminal 27 = E-03 Terminal 27 Digital Input [6] Stop inverse

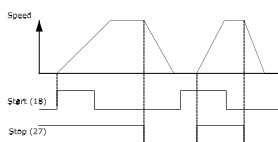
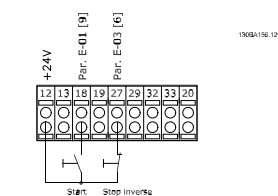

3.2.3 Speed Up/Down

Terminals 29/32 = Speed up/down

Terminal 18 = E-01 Terminal 18 Digital Input Start [9] (default)

Terminal 27 = E-03 Terminal 27 Digital Input Freeze reference [19]

Terminal 29 = E-04 Terminal 29 Digital Input Speed up [21]

Terminal 32 = E-05 Terminal 32 Digital Input Speed down [22]

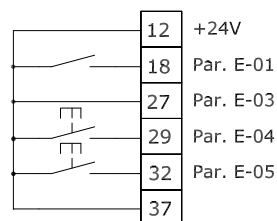

3.2.4 Potentiometer Reference

Voltage reference via a potentiometer

Reference Source 1 = [1] Analog input 53 (default)

Terminal 53, Low Voltage = 0V

Terminal 53, High Voltage = 10V

Terminal 53, Low Ref./Feedback = 0 RPM

Terminal 53, High Ref./Feedback = 1500 RPM

Switch S201 = OFF (U)

130BA154.11

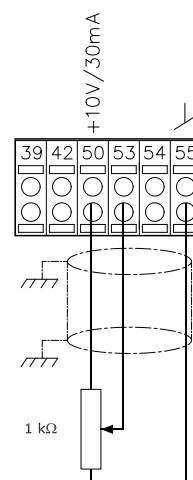
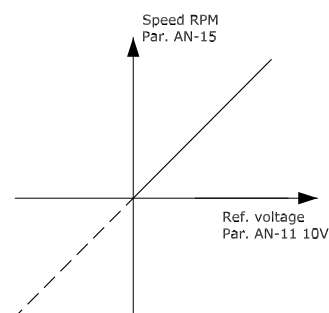



3.3 Electrical Installation - additional

3.3.1 Electrical Installation, Control Cables

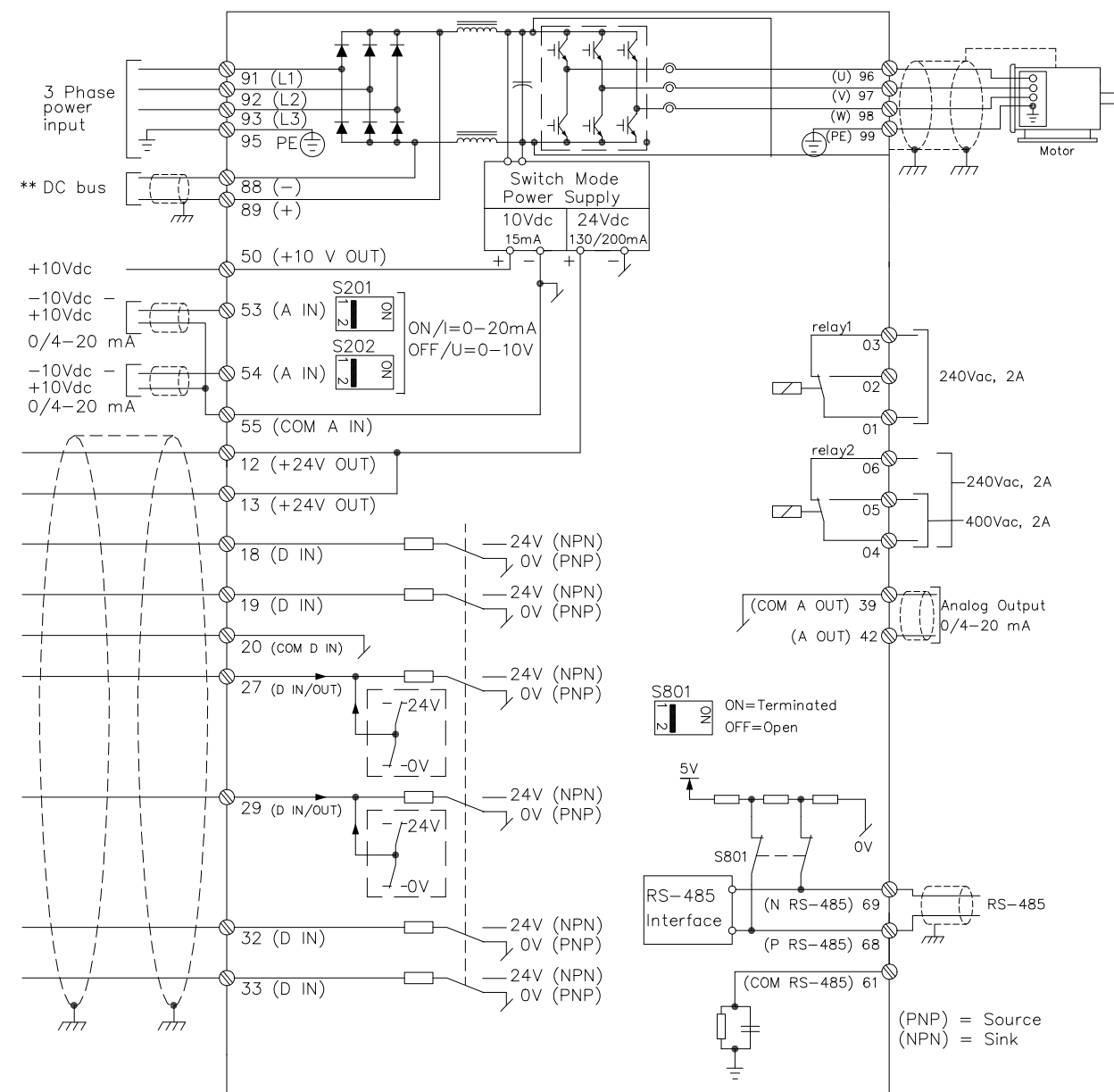

130BC025.11

Very long control cables and analogue signals may in rare cases and depending on installation result in 50/60Hz earth loops due to noise from mains supply cables.

If this occurs, it may be necessary to break the screen or insert a 100nF capacitor between screen and chassis.

The digital and analog inputs and outputs must be connected separately to the frequency converter common inputs (terminal 20, 55, 39) to avoid earth currents from both groups to affect other groups. For example, switching on the digital input may disturb the analog input signal.



Input polarity of control terminals

3

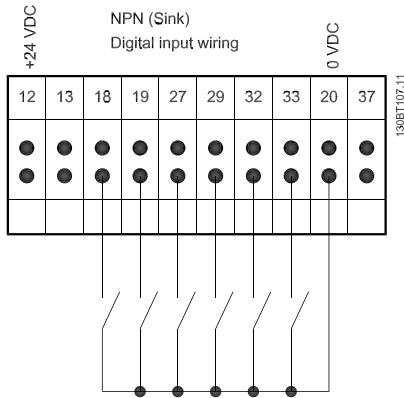
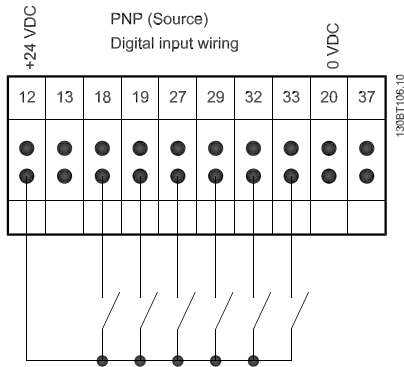

NOTE

Control cables must be screened/armoured.

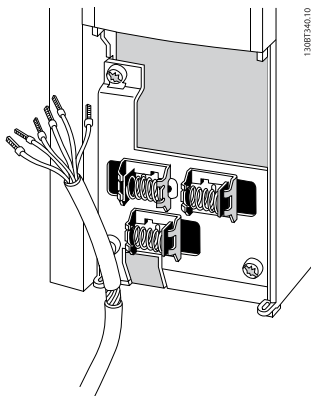

Connect the wires as described in the Operating Instruction for the frequency converter. Remember to connect the shields in a proper way to ensure optimum electrical immunity.

3.3.2 External Hand Off Auto Example

Hand Off Auto (HOA), without the use of the Drive keypad

To have a HOA system with an external 0-10V potentiometer for the hand reference and a 4-20mA signal for the auto reference, 2 set-ups should be used. In this example we use set-up 1 for the hand mode and set-up 2 for the auto mode. We use analog input 53 for the hand reference (0-10V potentiometer) and analog input 54 for the auto reference (4-20mA) and digital input 27 for the set-up selector. Please ensure that the analog inputs have the correct dip settings (A-53 [U] and A-54 [I]).

In the upper right corner of the keypad you can see 2 numbers – like 1(1). The number outside the parenthesis is the active set-up and the number inside the parenthesis is the set-up which will be edited. Default will always be 1(1). Make sure you edit set-up 1.

1. Make all the parameter changes you need, that will be common for auto and hand mode, like motor parameters etc.
2. Set par. K-10 *Active set-up* to [9] Multi Set-up. This parameter change is needed to be able to change set-up from an external source, like a digital input.
3. Set par. K-11 *Edit Set-up* to [9] Active Set-up. This is recommended because then the active setup will always be the set-up that is edited. If you prefer you can also ignore this and manually

control what set-up you want to edit through par. K-11.

4. Set par. E-03 *Terminal 27 Digital Input* to [23] Set-up select bit 0. When terminal 27 is OFF, set-up 1 (hand) is active, when it is ON, set-up 2 (auto) is active.
5. Set par. F-01 *Frequency Setting 1* to Analog input 53 (hand mode).
6. Ensure par. C-30 *Frequency Command 2* and par. C-34 *Frequency Command 3* are both No Function. This is good practice to make sure no other references are added.
7. Copy set-up 1 to set-up 2. Set par. K-51 *Set up Copy* to [2] Copy to set-up 2. Now setup 1 and 2 are identical.
8. If you need to be able to change between hand and auto mode while the motor is running you will have to link the 2 set-ups together. Set par. K-12 *This Set-up Linked to* to [2] set-up 2.
9. Change to set-up 2 by setting input 27 ON (if par. K-11 is [9]) or by setting par. K-11 *Edit Set-up* to set-up 2.
10. Set par. F-01 *Frequency Setting 1* to Analog input 54 (auto mode).

If you want different settings in hand and auto mode, like different accel/decel ramps, speed limits etc. you can now programme them. You just have to make sure you edit the correct set-up. Set-up 1 is Hand mode and set-up 2 is Auto mode.

External Hand-Off-Auto Selector Switch Wiring

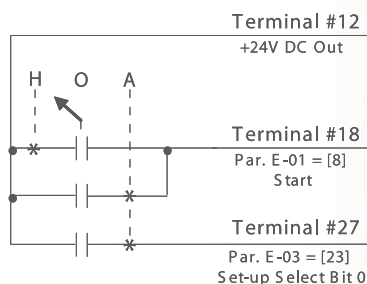

Illustration 3.16 GE 30mm HOA Cat# (1) 104PSG34B & (3) CR104PXC1



3.3.3 Switches S201, S202, and S801

Switches S201 (A53) and S202 (A54) are used to select a current (0-20mA) or a voltage (-10 to 10V) configuration of the analog input terminals 53 and 54 respectively.

Switch S801 (BUS TER.) can be used to enable termination on the RS-485 port (terminals 68 and 69).

See drawing *Diagram* showing all electrical terminals in section *Electrical Installation*.

Default setting:

S201 (A53) = OFF (voltage input)

S202 (A54) = OFF (voltage input)

S801 (Bus termination) = OFF

NOTE

When changing the function of S201, S202 or S801 be careful not to use force for the switch over. It is recommended to remove the keypad fixture (cradle) when operating the switches. The switches must not be operated with power on the frequency converter.

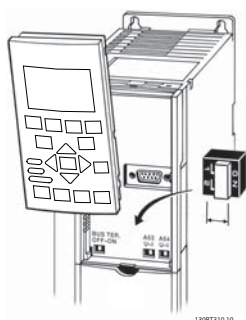

3.4 Final Set-up and Test

To test the set-up and ensure that the frequency converter is running, follow these steps.

Step 1. Locate the motor name plate

NOTE

The motor is either star- (Y) or delta- connected (Δ). This information is located on the motor name plate data.

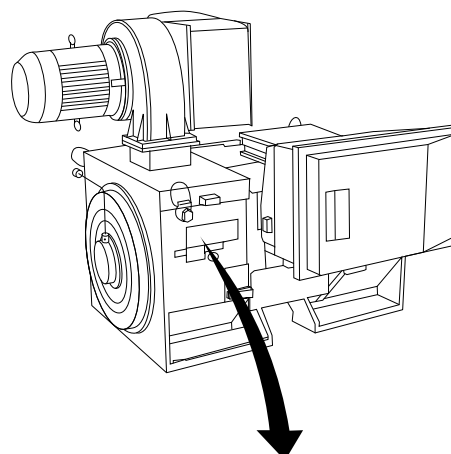

130BA767.10

THREE PHASE INDUCTION MOTOR					
MOD MCV 315E	Nr.	135189 12 04		IL/IN 6.5	
kW 400	PRIMARY			SF 1.15	
HP 536	V 690	A 410.6	CONN Y	COS f 0.85	40
mm 1481	V	A	CONN	AMB 40	°C
Hz 50	V	A	CONN	ALT 1000	m
DESIGNN	SECONDARY			RISE 80	°C
DUTY S1	V	A	CONN	ENCLOSURE IP23	
INSUL I	EFFICIENCY %	95.8%	100%	95.8%	75%
					WEIGHT 1.83 ton

CAUTION

Step 2. Enter the motor name plate data in this parameter list.

To access this list first press the [QUICK MENU] key then select "Quick Setup". Use the up and down arrow keys to navigate to the parameters associated with the motor nameplate values.

1.	P-07 Motor Power [kW] P-02 Motor Power [HP]
2.	F-05 Motor Rated Voltage
3.	F-04 Base Frequency
4.	P-03 Motor Current
5.	P-06 Base Speed

Step 3. Activate the Auto tune

Performing an auto tune will ensure optimum performance. The auto tune measures the values from the motor model equivalent diagram.

1. Activate the auto tune P-04 Auto Tune.
2. Choose between complete or reduced auto tune. If a Sine-wave filter is mounted, run only the reduced auto tune, or remove the Sine-wave filter and run complete Auto Tune.
3. Press the [OK] key. The display shows "Press [Hand] to start".
4. Press the [Hand] key. A progress bar indicates if the auto tune is in progress.

Stop the auto tune during operation

1. Press the [OFF] key - the frequency converter enters into alarm mode and the display shows that the auto tune was terminated by the user.

Successful auto tune

1. The display shows "Press [OK] to finish auto tune".
2. Press the [OK] key to exit the auto tune state.

Unsuccessful auto tune

1. The frequency converter enters into alarm mode. A description of the alarm can be found in the *Warnings and Alarms* chapter.
2. "Report Value" in the [Alarm Log] shows the last measuring sequence carried out by the auto tune, before the frequency converter entered alarm mode. This number along with the description of the alarm will assist you in troubleshooting. If you contact GE for service, make sure to mention number and alarm description.

NOTE

Unsuccessful auto tune is often caused by incorrectly entering motor name plate data or a too big difference between the motor power size and the frequency converter power size.

Step 4. Set speed limit and accel/decel times.

F-52 Minimum Reference

F-53 Maximum Reference

Set up the desired limits for speed and ramp time

F-18 Motor Speed Low Limit [RPM] or F-16 Motor Speed Low Limit [Hz]

F-17 Motor Speed High Limit [RPM] or F-15 Motor Speed High Limit [Hz]

F-07 Accel Time 1

F-08 Decel Time 1

3.5 Additional Connections

3.5.1 Parallel Connection of Motors

The frequency converter can control several parallel-connected motors. The total current consumption of the motors must not exceed the rated output current $I_{M,N}$ for the frequency converter.

NOTE

Installations with cables connected in a common joint as in the illustration below, is only recommended for short cable lengths.

NOTE

When motors are connected in parallel, *P-04 Auto Tune* cannot be used.

NOTE

The electronic thermal overload of the frequency converter cannot be used as motor protection for the individual motor in systems with parallel-connected motors. Provide further motor protection by e.g. thermistors in each motor or individual thermal relays (circuit breakers are not suitable as protection).

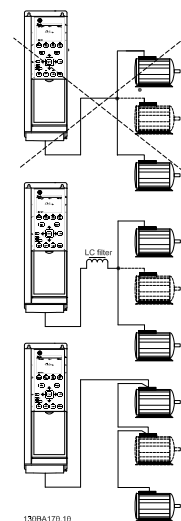

Problems may arise at start and at low RPM values if motor sizes are widely different because small motors' relatively high ohmic resistance in the stator calls for a higher voltage at start and at low RPM values.

4 Mechanical Installation

4.1 How to Get Started

This chapter covers mechanical and electrical installations to and from power terminals and control card terminals. Electrical installation of *options* is described in the relevant Operating Instructions and Design Guide.

⚠️ WARNING

Read the safety instructions before installing the unit.
Failure to follow recommendations could result in death or serious injury.

Mechanical Installation

- Mechanical mounting

Electrical Installation

- Connection to Mains and Protecting Earth
- Motor connection and cables
- Fuses and circuit breakers
- Control terminals - cables

Quick Setup

- keypad
- Auto Tune
- Programming

Unit size is depending on enclosure type, power range and mains voltage

The frequency converter is designed to achieve a quick and EMC-correct installation by following the steps described below.

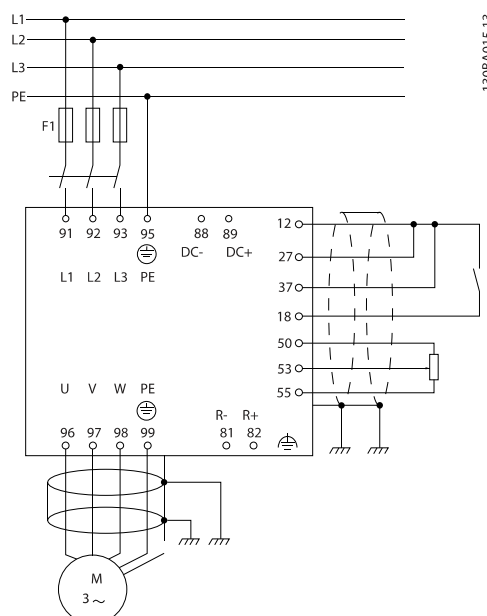

Illustration 4.1 Diagram showing basic installation including mains, motor, start/stop key, and potentiometer for speed adjustment.



4.2 Pre-installation

4.2.1 Planning the Installation Site

CAUTION

Before performing the installation it is important to plan the installation of the frequency converter. Neglecting this may result in extra work during and after installation.

Select the best possible operation site by considering the following (see details on the following pages, and the respective Design Guides):

- Ambient operating temperature
- Installation method
- How to cool the unit
- Position of the frequency converter
- Cable routing
- Ensure the power source supplies the correct voltage and necessary current
- Ensure that the motor current rating is within the maximum current from the frequency converter
- Ensure that the drive is properly protected per local regulations.

4.2.2 Receiving the Frequency Converter

When receiving the frequency converter please make sure that the packaging is intact, and be aware of any damage that might have occurred to the unit during transport. In case damage has occurred, contact immediately the shipping company to claim the damage.

4.2.3 Transportation and Unpacking

Before unpacking the frequency converter it is recommended that it is located as close as possible to the final installation site.

Remove the box and handle the frequency converter on the pallet, as long as possible.

4.2.4 Lifting

Always lift the drive in the dedicated lifting eyes. For all 4X unit size and 52 unit size (IP00) Units, use a bar to avoid bending the lifting holes of the drive.

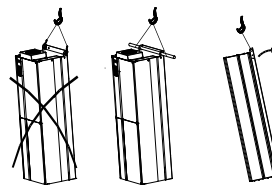

Illustration 4.2 Recommended Lifting Method, 4X and 5X Unit Sizes .

WARNING

The lifting bar must be able to handle the weight of the drive. See *Mechanical Dimensions* for the weight of the different Unit Sizes. Maximum diameter for bar is 2.5 cm (1 inch). The angle from the top of the drive to the lifting cable should be 60° or greater.

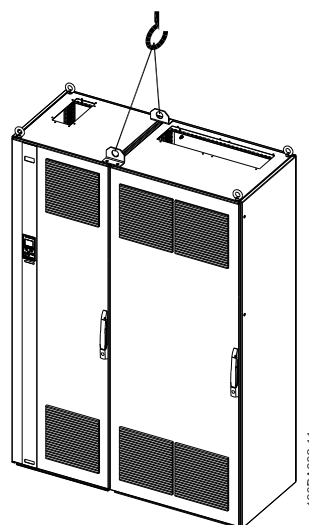

Illustration 4.3 Recommended Lifting Method, Unit Size 61 (460V, 600 to 900 HP, 575/600V, 900 to 1150 HP).



4

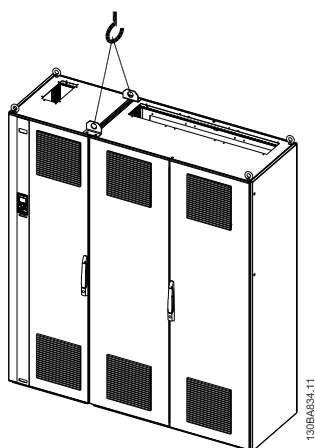

Illustration 4.4 Recommended Lifting Method, Unit Size 62 (460V, 1000 to 1200 HP, 575/600V, 1250 to 1350 HP).

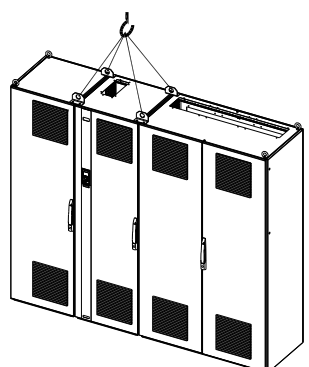

Illustration 4.6 Recommended Lifting Method, Unit Size 64 (460V, 1000 to 1200 HP, 575/600V, 1250 to 1350 HP).

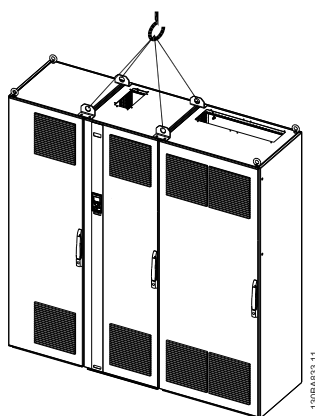

Illustration 4.5 Recommended Lifting Method, Unit Size 63 (460V, 600 to 900 HP, 575/600V, 900 to 1150 HP).

NOTE

The plinth is provided in the same packaging as the drive but is not attached to Unit Sizes 61-64 during shipment. The plinth is required to allow airflow to the drive to provide proper cooling. The unit sizes 6X should be positioned on top of the plinth in the final installation location. The angle from the top of the drive to the lifting cable should be 60° or greater.

In addition to the drawings above a spreader bar is an acceptable way to lift the unit sizes 6X.

4.2.5 Mechanical Dimensions

Unit Size 41

IP21 AND IP54 / UL AND NEMA TYPE 1 AND 12

Unit Size 42

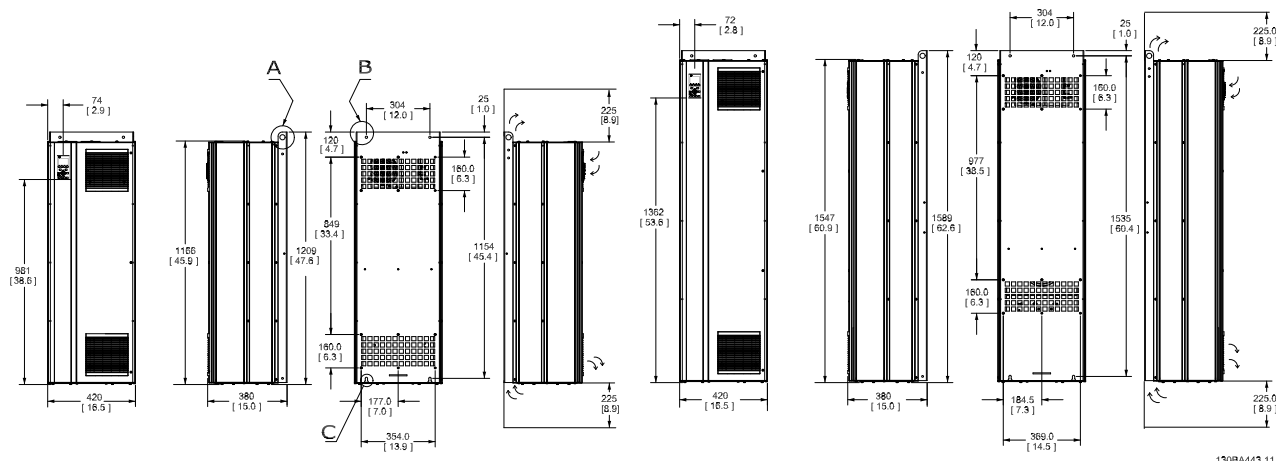

130BA443.11

* Please note airflow directions

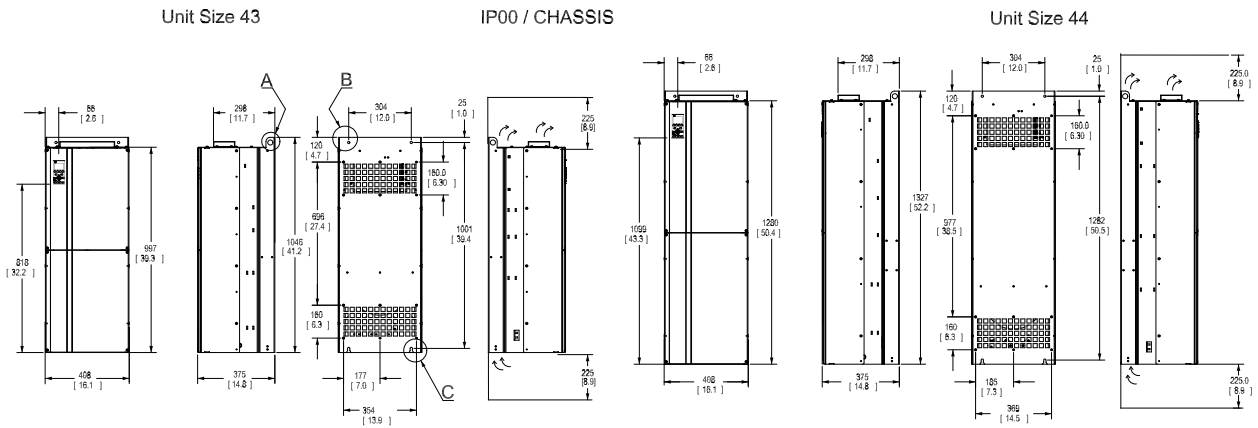

1388A442.10

IP00/IP21/IP54 - ALL SIZES

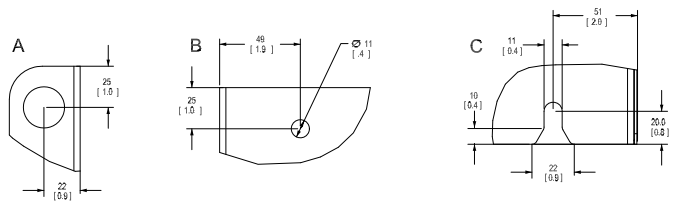

* Please note airflow directions



Unit Size 51

IP21 AND IP54 / UL AND NEMA TYPE 1 AND 12

4

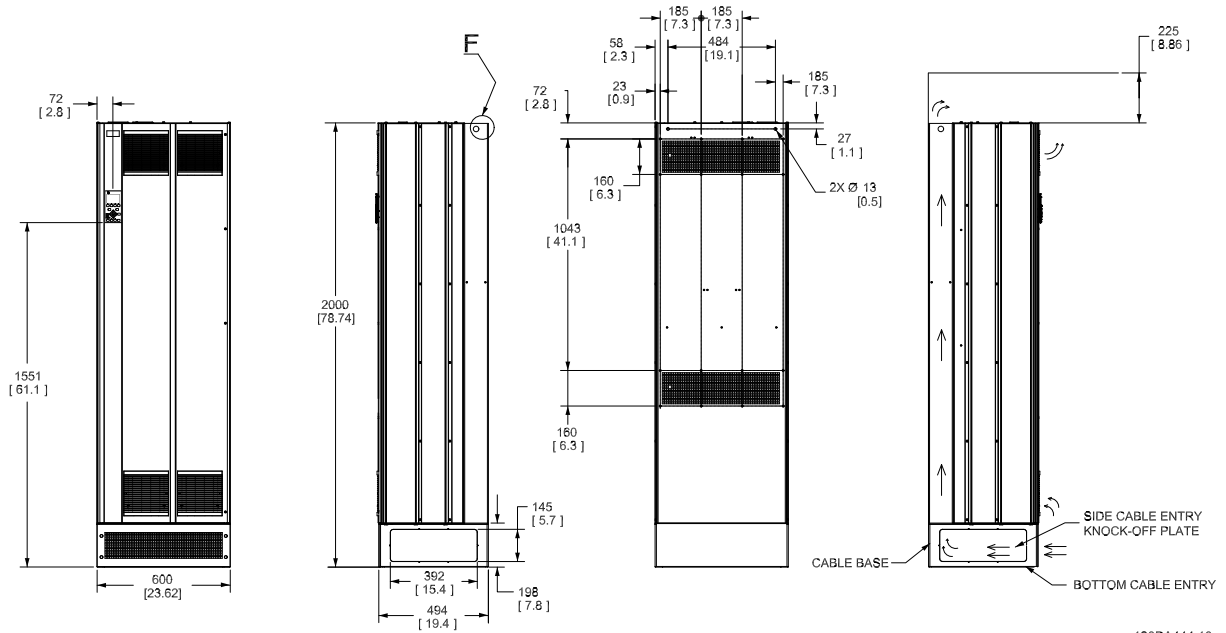

130BA444.10

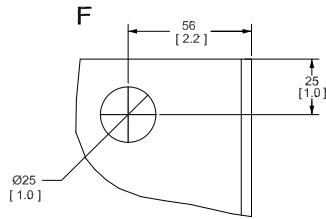

* Please note airflow directions



Unit Size 52

IP00 / CHASSIS

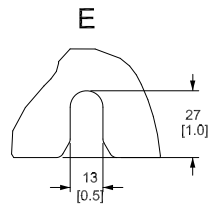
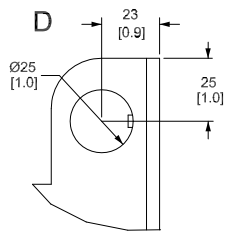
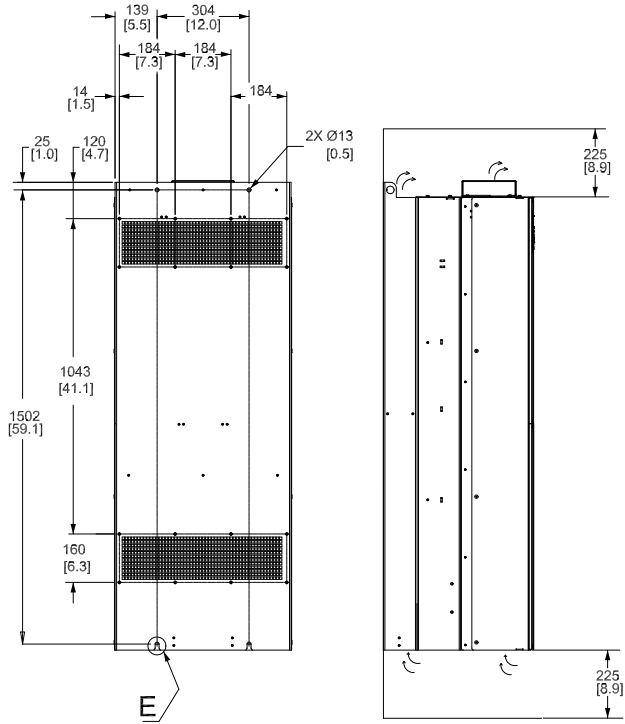
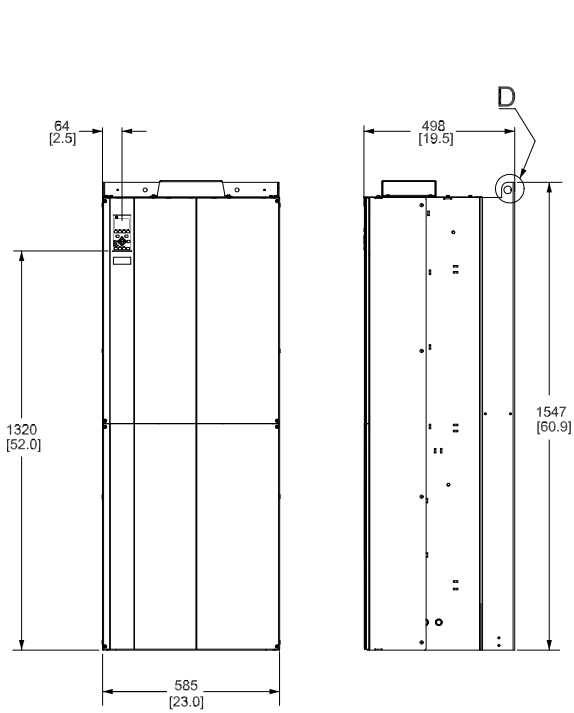

130BA445.10

* Please note airflow directions



4

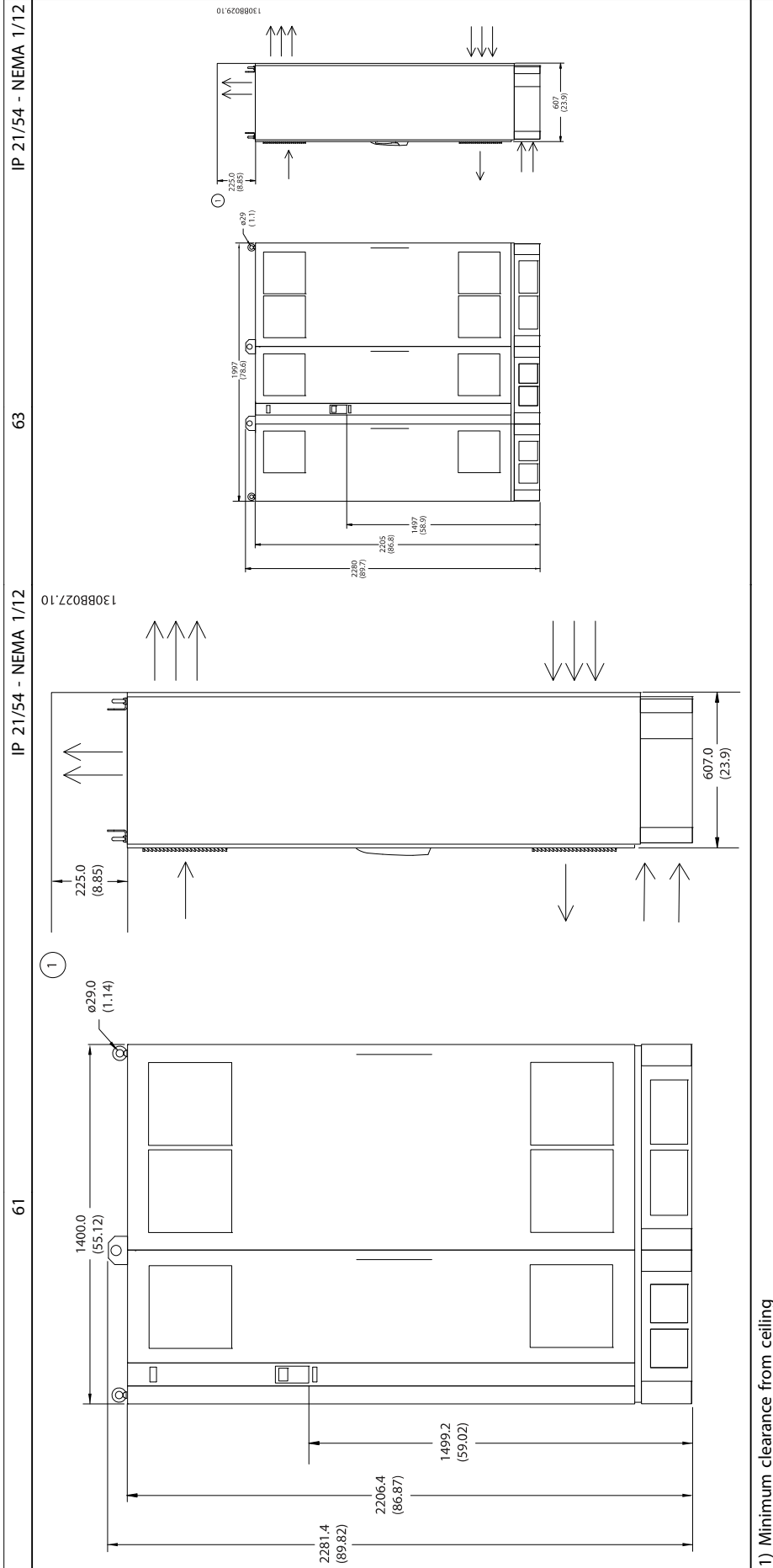



IP 21/54 - NEMA 1/12

64

IP 21/54 - NEMA 1/12

62

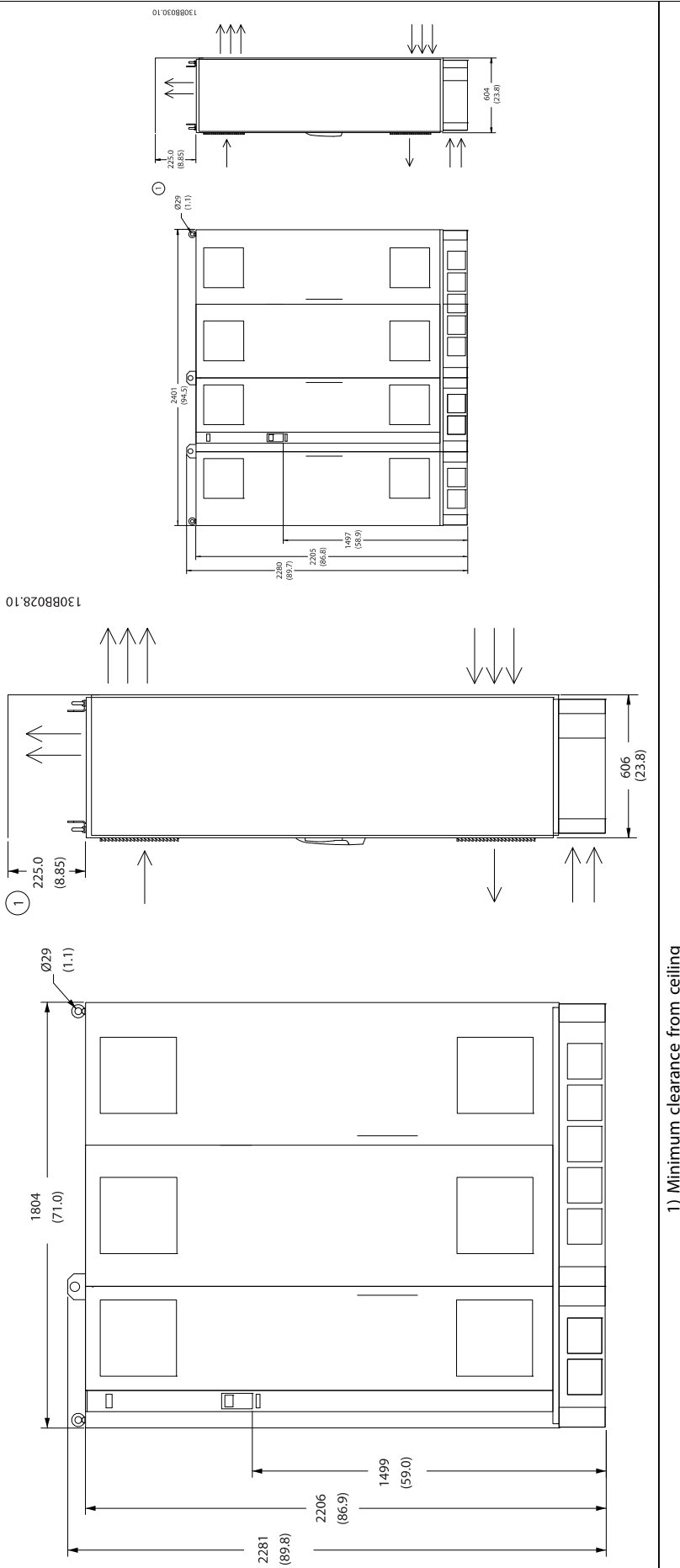



Mechanical Installation

AF-600 FP High Power Operating Instructions

4

Mechanical dimensions , 4X Unit Sizes							
Unit Size		41		42		43	44
		150-200HP at 460V (380-480V) 150-200HP at 575V (525-600V)		250-350HP at 460V (380-480V) 250-400HP at 575V (525-600V)		150-200HP at 460V (380-480V) 150-200HP at 575V (525-600V)	250-350HP at 460V (380-480V) 250-400HP at 575V (525-600V)
IP NEMA		21 Type 1	54 Type 12	21 Type 1	54 Type 12	00 Chassis	00 Chassis
Shipping dimensions	Height [mm]	650	650	650	650	650	650
	Width [mm]	1730	1730	1730	1730	1220	1490
	Depth [mm]	570	570	570	570	570	570
Drive dimensions	Height [mm]	1209	1209	1589	1589	104	1327
	Width [mm]	420	420	420	420	408	408
	Depth [mm]	380	380	380	380	375	375
	Max weight [kg]	104	104	151	151	91	138

Mechanical dimensions, 5X and 6X Unit Sizes							
Unit Size		51	52	61	62	63	64
		350 - 600HP at 460V (380-480V) 450-650HP at 575V (525-600V)	650-1000HP at 460V (380-480V) 750-1050HP at 575V (525-600V)	650-1000HP at 460V (380-480V) 750-1050HP at 575V (525-600V)	1200-1350HP at 460V (380-480V) 1150-1350HP at 575V (525-600V)	650-1000HP at 460V (380-480V) 750-1050HP at 575V (525-600V)	1200-1350HP at 460V (380-480V) 1150-1350HP at 575V (525-600V)
IP NEMA		21, 54 Type 1/ Type 12	00 Chassis	21, 54 Type 1/ Type 12	21, 54 Type 1/ Type 12	21, 54 Type 1/ Type 12	21, 54 Type 1/ Type 12
Shipping dimensions	Height [mm]	840	831	2324	2324	2324	2324
	Width [mm]	2197	1705	1569	1962	2159	2559
	Depth [mm]	736	736	1130	1130	1130	1130
Drive dimensions	Height [mm]	2000	1547	2204	2204	2204	2204
	Width [mm]	600	585	1400	1800	2000	2400
	Depth [mm]	494	498	606	606	606	606
	Max weight [kg]	313	277	1004	1246	1299	1541

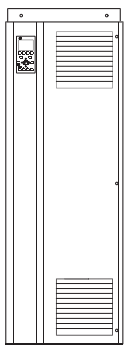
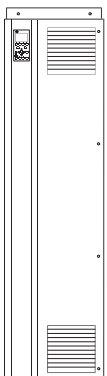
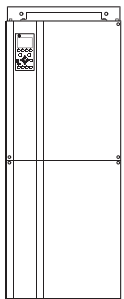
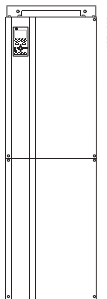

4.2.6 Rated Power

Unit Size	41		42		43		44	
								
	IP	21/54	21/54	21/54	00	00	00	00
	NEMA	Type 1/ Type 12	Type 1/ Type 12	Type 1/ Type 12	Chassis	Chassis	Chassis	Chassis
Light duty rated power - 110% overload torque		150 - 200 HP at 460 V (380 - 480 V)	250 - 350 HP at 460 V (380 - 480 V)	250 - 400 HP at 575 V (525-600 V)	150 - 200 HP at 460 V (380 - 480 V)	150 - 200 HP at 575 V (525-600 V)	250 - 350 HP at 460 V (380 - 480 V)	250 - 400 HP at 575 V (525-600 V)
		150 - 200 HP at 575 V (525-600 V)	250 - 400 HP at 575 V (525-600 V)					

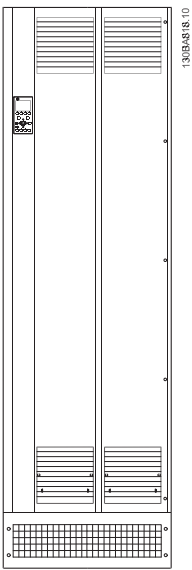
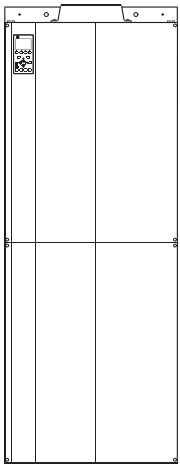
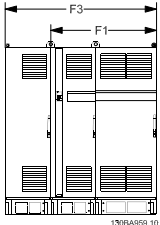
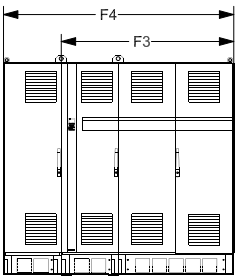
Unit Size	51		52		61/63		62/64	
								
	IP	21/54	00	00	21/54	21/54	21/54	21/54
	NEMA	Type 1/ Type 12	Chassis	Chassis	Type 1/ Type 12	Type 1/ Type 12	Type 1/ Type 12	Type 1/ Type 12
Light duty rated power - 110% overload torque		350 - 600 HP at 460 V (380 - 480 V)	350 - 600 HP at 460 V (380 - 480 V)	350 - 600 HP at 460 V (380 - 480 V)	650 - 1000 HP at 460 V (380 - 480 V)	650 - 1000 HP at 460 V (380 - 480 V)	1200 - 1350 HP at 460 V (380 - 480 V)	1200 - 1350 HP at 460 V (380 - 480 V)
		450 - 650 HP at 575 V (525-600 V)	450 - 650 HP at 575 V (525-600 V)	450 - 650 HP at 575 V (525-600 V)	750 - 1050 HP at 575 V (525-600 V)	750 - 1050 HP at 575 V (525-600 V)	1150 - 1350 HP at 575 V (525-600 V)	1150 - 1350 HP at 575 V (525-600 V)

NOTE

The unit sizes 6X have four different sizes, 61, 62, 63 and 64. The 61 and 62 consist of an inverter cabinet on the right and rectifier cabinet on the left. The 63 and 64 have an additional options cabinet left of the rectifier cabinet. The 63 is a 61 with an additional options cabinet. The 64 is an 62 with an additional options cabinet.

4.3 Mechanical Installation

Preparation of the mechanical installation of the frequency converter must be done carefully to ensure a proper result and to avoid additional work during installation. Start taking a close look at the mechanical drawings at the end of this instruction to become familiar with the space demands.

4

4.3.1 Tools Needed

To perform the mechanical installation the following tools are needed:

- Drill with 10 or 12 mm drill
- Tape measure
- Wrench with relevant metric sockets (7-17 mm)
- Extensions to wrench
- Sheet metal punch for conduits or cable glands in IP 21/Nema 1 and IP 54/Nema 12 drive types.
- Lifting bar to lift the unit (rod or tube max. Ø 25 mm (1 inch), able to lift minimum 400 kg (880 lbs)).
- Crane or other lifting aid to place the frequency converter in position
- A Torx T50 tool is needed to install the Unit Size 51IP 21/Nema 1 and IP 54/Nema 12 drive types.

4.3.2 General Considerations

Wire access

Ensure that proper cable access is present including necessary bending allowance. As the IP00 Open Chassis drive type is open to the bottom cables must be fixed to the back panel of the Unit where the frequency converter is mounted, i.e. by using cable clamps.

CAUTION

All cable lugs/ shoes must mount within the width of the terminal bus bar.

Space

Ensure proper space above and below the frequency converter to allow airflow and cable access. In addition space in front of the unit must be considered to enable opening of the door of the panel.

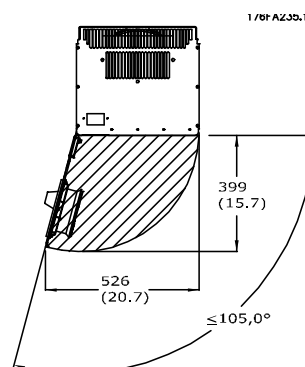

Illustration 4.7 Space in front of IP21/Nema 1 and IP54/Nema 12 drive in unit sizes 41 and 42.

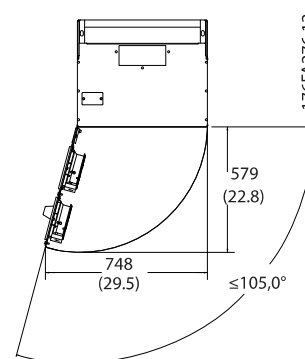

Illustration 4.8 Space in front of IP21/Nema 1 and IP54/Nema 12 drive types for unit size 51.

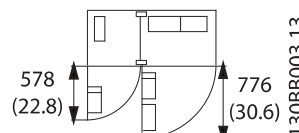

Illustration 4.9 Space in front of IP21/Nema 1 and IP54/Nema 12 drive types for unit size 61.

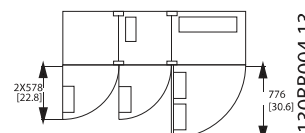

Illustration 4.10 Space in front of IP21/Nema 1 and IP54/Nema 12 drive types for unit size 63.

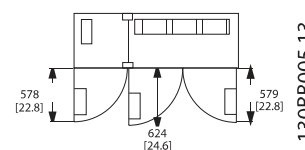

Illustration 4.11 Space in front of IP21/Nema 1 and IP54/Nema 12 drive types for unit size 62.

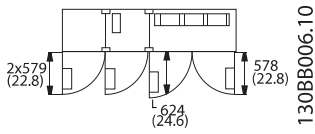

Illustration 4.12 Space in front of IP21/Nema 1 and IP54/Nema drive types for unit size 64.

4.3.3 Terminal Locations - Unit Size 4X

Take the following position of the terminals into consideration when you design for cables access.

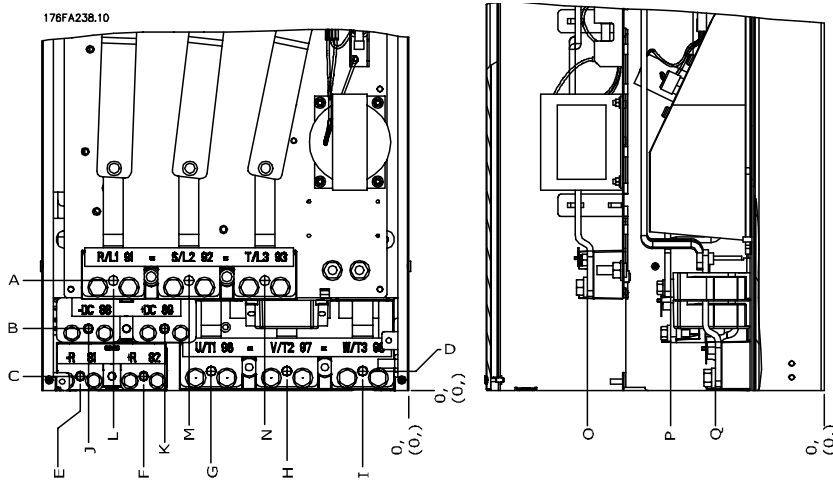

Illustration 4.13 Position of power connections, 43/44 Unit Sizes

Be aware that the power cables are heavy and hard to bend. Consider the optimum position of the frequency converter for ensuring easy installation of the cables.

**NOTE**

All 4X Unit Sizes are available with standard input terminals. All terminal dimensions can be found in the following table.

	IP21 (NEMA 1) / IP54 (NEMA 12)		IP00 / Chassis	
	Unit Size 41	Unit Size 42	Unit Size 43	Unit Size 44
A	277 (10.9)	379 (14.9)	119 (4.7)	122 (4.8)
B	227 (8.9)	326 (12.8)	68 (2.7)	68 (2.7)
C	173 (6.8)	273 (10.8)	15 (0.6)	16 (0.6)
D	179 (7.0)	279 (11.0)	20.7 (0.8)	22 (0.8)
E	370 (14.6)	370 (14.6)	363 (14.3)	363 (14.3)
F	300 (11.8)	300 (11.8)	293 (11.5)	293 (11.5)
G	222 (8.7)	226 (8.9)	215 (8.4)	218 (8.6)
H	139 (5.4)	142 (5.6)	131 (5.2)	135 (5.3)
I	55 (2.2)	59 (2.3)	48 (1.9)	51 (2.0)
J	354 (13.9)	361 (14.2)	347 (13.6)	354 (13.9)
K	284 (11.2)	277 (10.9)	277 (10.9)	270 (10.6)
L	334 (13.1)	334 (13.1)	326 (12.8)	326 (12.8)
M	250 (9.8)	250 (9.8)	243 (9.6)	243 (9.6)
N	167 (6.6)	167 (6.6)	159 (6.3)	159 (6.3)
O	261 (10.3)	260 (10.3)	261 (10.3)	261 (10.3)
P	170 (6.7)	169 (6.7)	170 (6.7)	170 (6.7)
Q	120 (4.7)	120 (4.7)	120 (4.7)	120 (4.7)
R	256 (10.1)	350 (13.8)	98 (3.8)	93 (3.7)
S	308 (12.1)	332 (13.0)	301 (11.8)	324 (12.8)
T	252 (9.9)	262 (10.3)	245 (9.6)	255 (10.0)
U	196 (7.7)	192 (7.6)	189 (7.4)	185 (7.3)
V	260 (10.2)	273 (10.7)	260 (10.2)	273 (10.7)

Table 4.1 Cable positions as shown in drawings above. Dimensions in mm (inch).



4.3.4 Terminal Locations - Unit Size 5X

Terminal Locations - Unit Size 51

Take the following position of the terminals into consideration when designing the cable access.

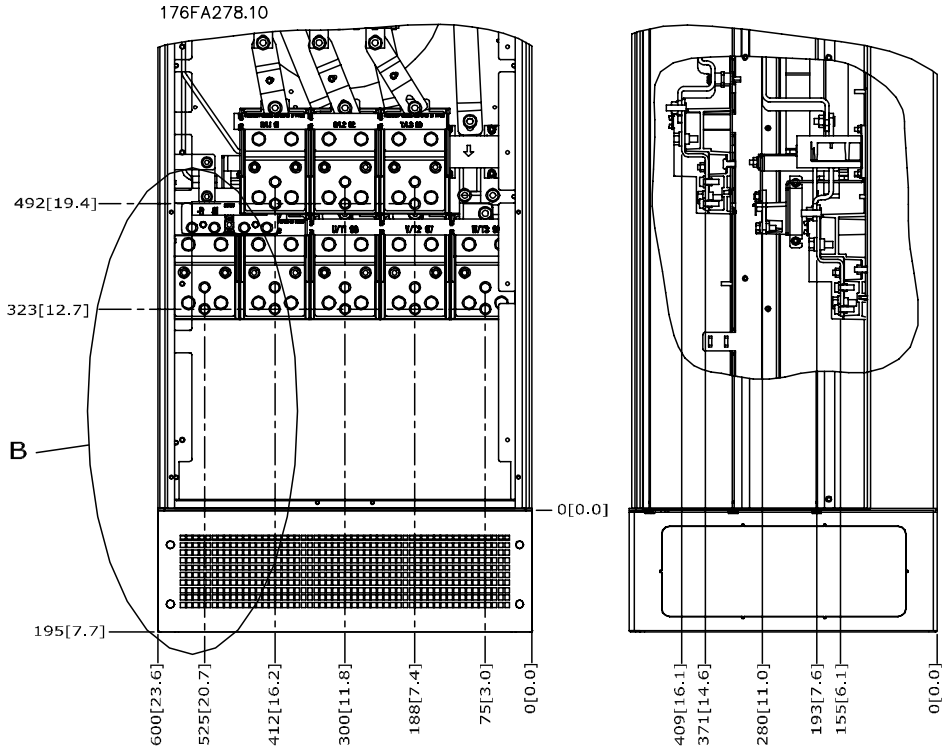

Illustration 4.14 IP21 (NEMA Type 1) and IP54 (NEMA Type 12) drive type power connection positions

4

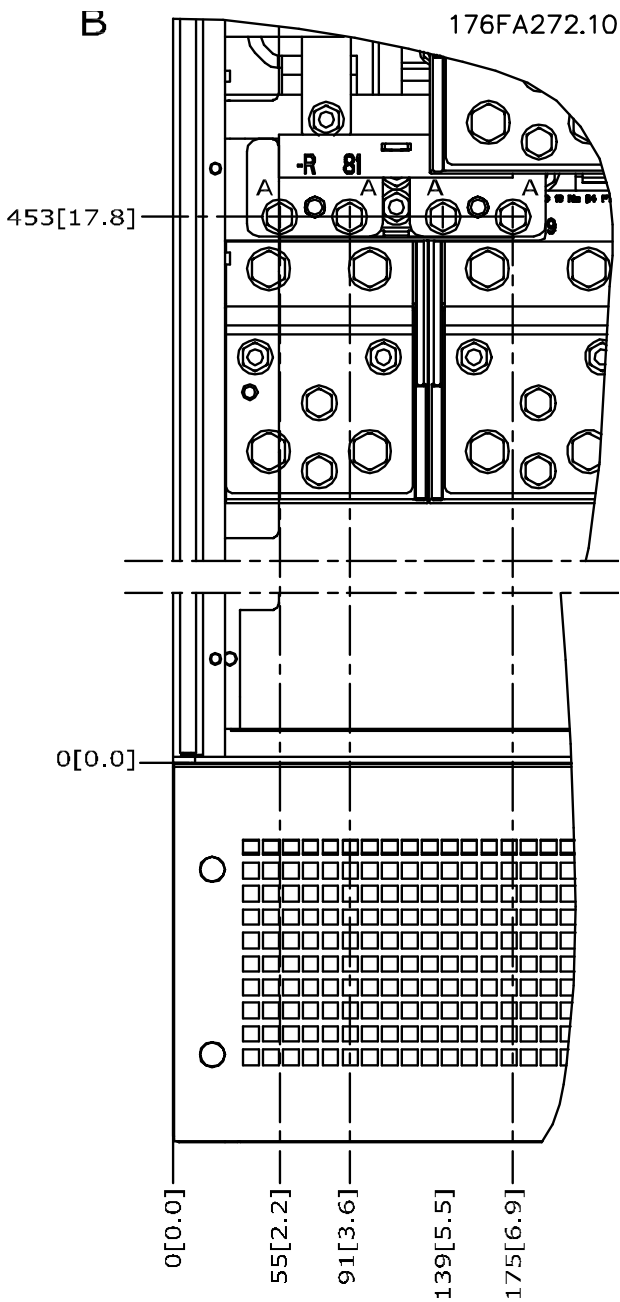

Illustration 4.15 IP21 (NEMA type 1) and IP54 (NEMA type 12) drive type power connection positions (detail B)

Terminal locations - Unit Size 52

Take the following position of the terminals into consideration when designing the cable access.

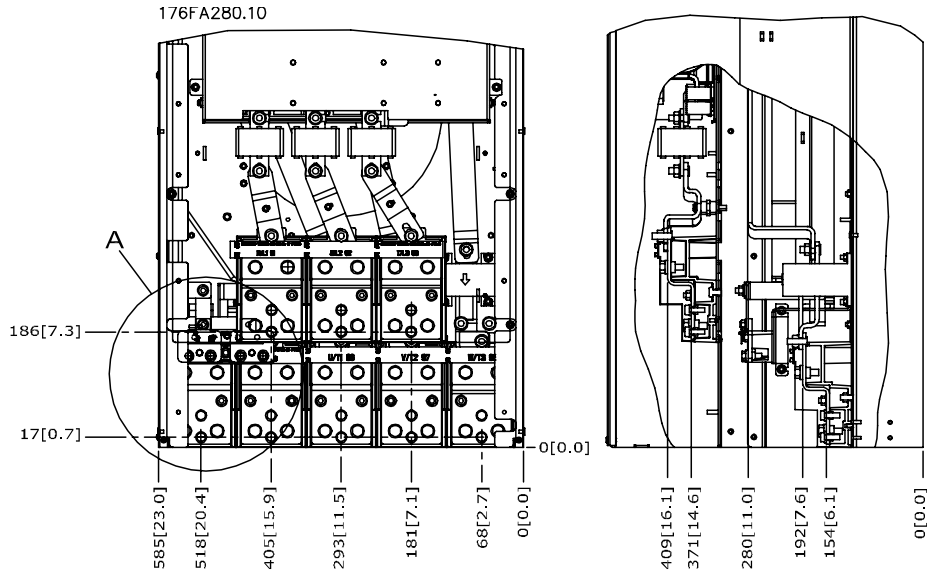

Illustration 4.16 IP00 Open Chassis drive type power connection positions

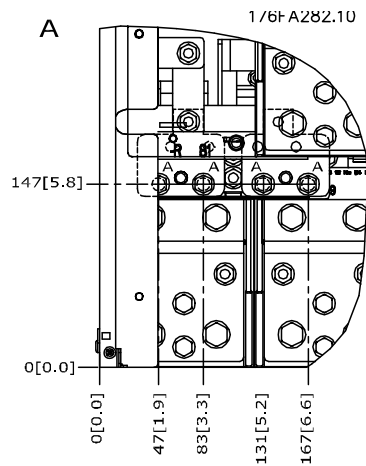

Illustration 4.17 IP00 Open Chassis drive type power connection positions

NOTE

The power cables are heavy and difficult to bend. Consider the optimum position of the drive for ensuring easy installation of the cables.

Each terminal allows use of up to 4 cables with cable lugs or use of standard box lug. Earth is connected to relevant termination point in the drive.

4

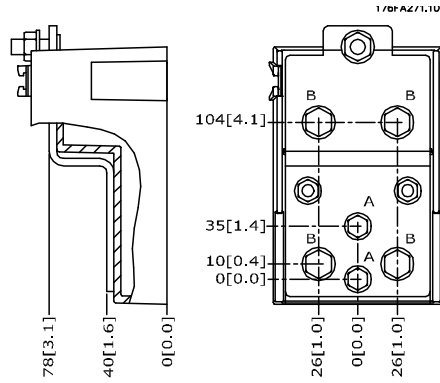

Illustration 4.18 Terminal in details

NOTE

Power connections can be made to positions A or B

4.3.5 Terminal Locations - Unit Sizes 6X

Terminal locations - Unit Sizes 61 and 63

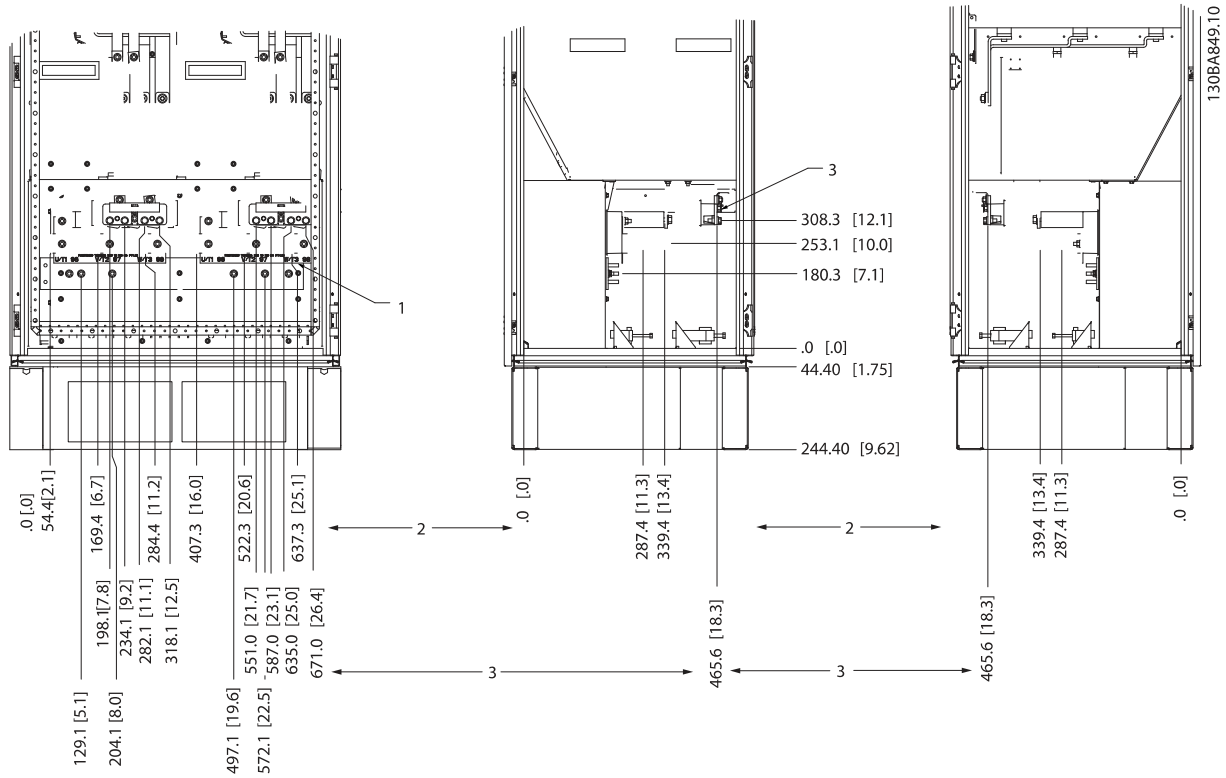

Illustration 4.19 Terminal locations - Inverter Cabinet - 61 and 63 (front, left and right side view). The gland plate is 42 mm below .0 level.

- 1) Ground bar
- 2) Motor terminals
- 3) Brake terminals

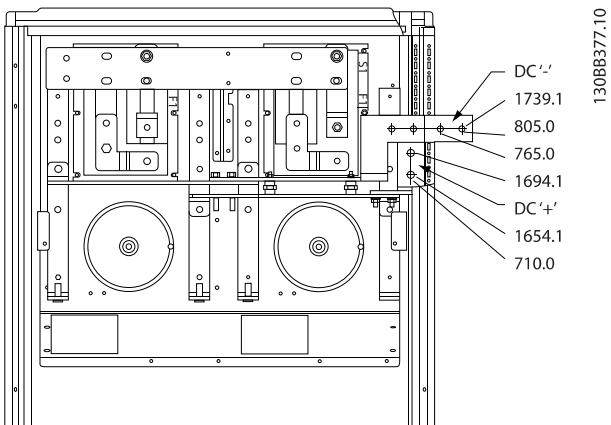

Illustration 4.20 Terminal Locations - Regen Terminals

Terminal locations - Unit Sizes 62/64

4

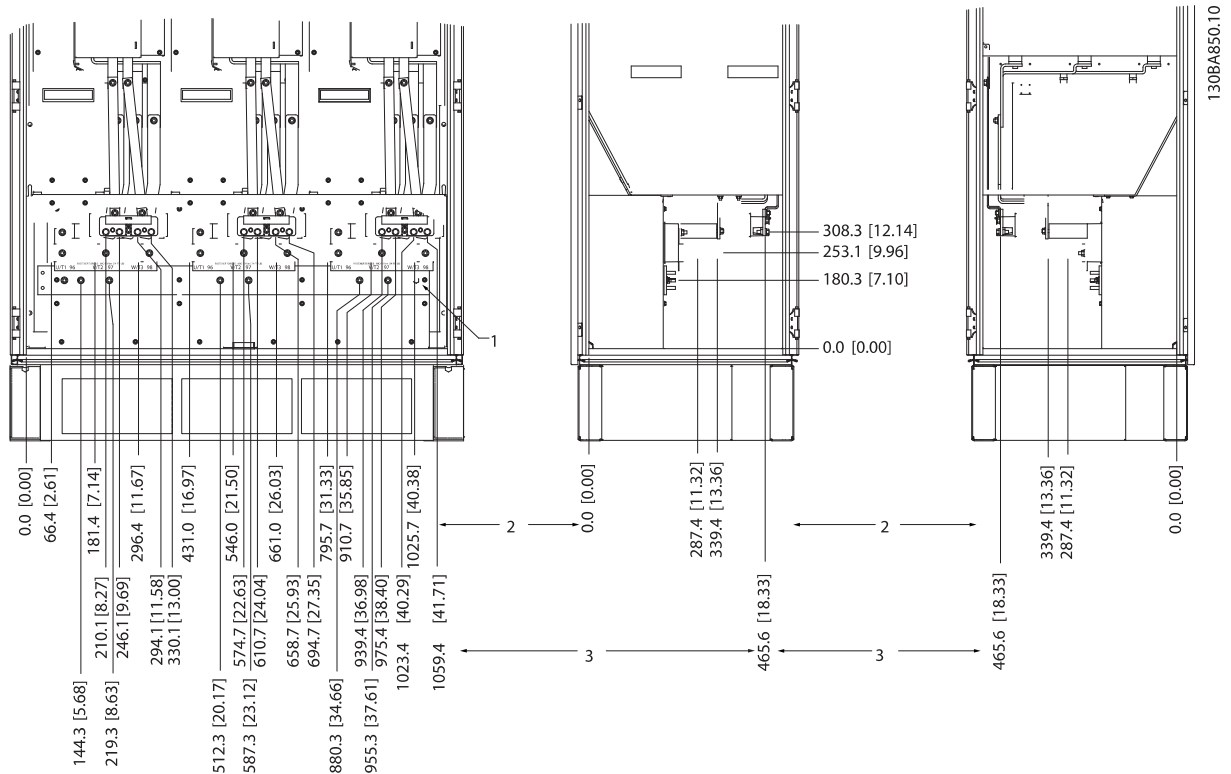

Illustration 4.21 Terminal locations - Inverter Cabinet - 62 and 64 (front, left and right side view). The gland plate is 42 mm below .0 level.

1) Ground bar

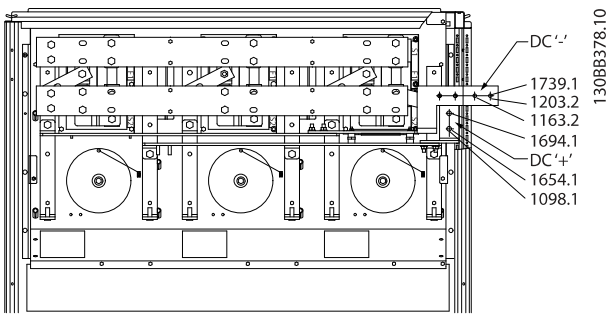

Illustration 4.22 Terminal Locations - Regen Terminals



Terminal locations - Rectifier (Unit Sizes 61, 62, 63 and 64)

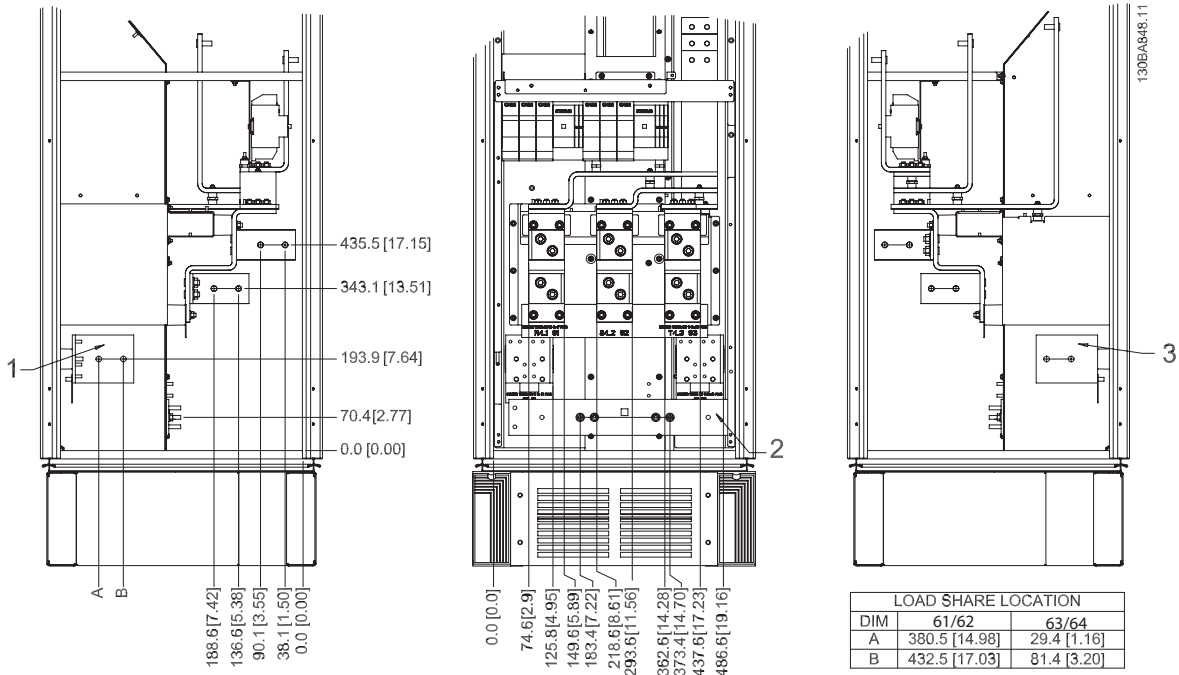

Illustration 4.23 Terminal locations - Rectifier (Left side, front and right side view). The gland plate is 42 mm below .0 level.

- 1) Loadshare Terminal (-)
- 2) Ground bar
- 3) Loadshare Terminal (+)

Terminal locations - Options Cabinet (Unit Sizes 63 and 64)

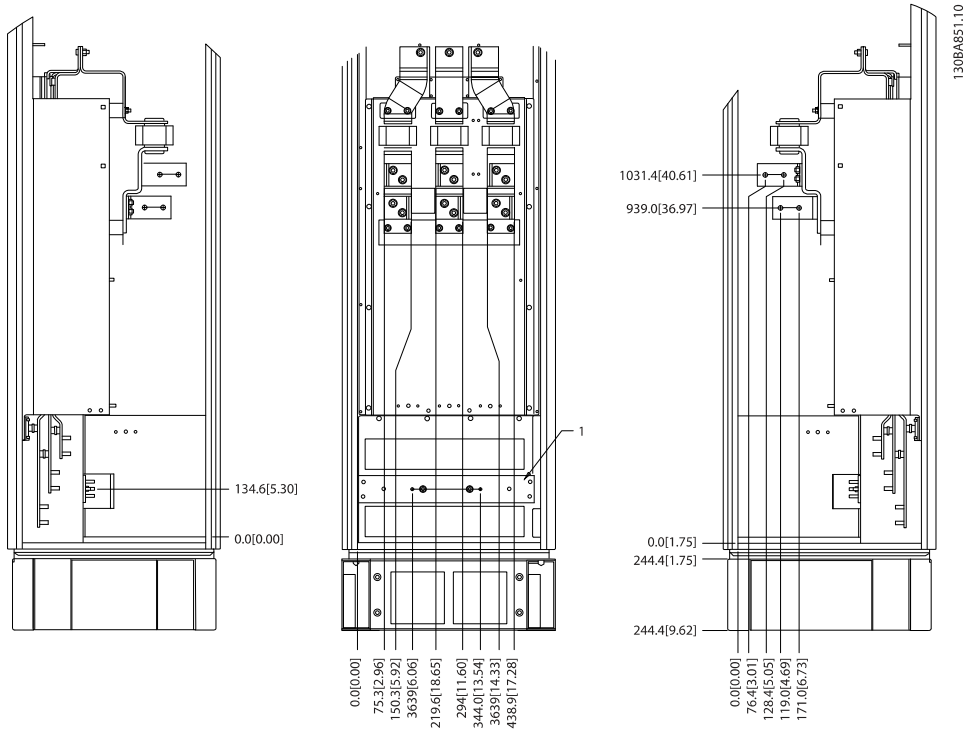

Illustration 4.24 Terminal locations - Options Cabinet (Left side, front and right side view). The gland plate is 42 mm below .0 level.

- 1) Ground bar



Terminal locations - Options Cabinet with circuit breaker/ molded case switch (Unit Sizes 63 and 64)

4

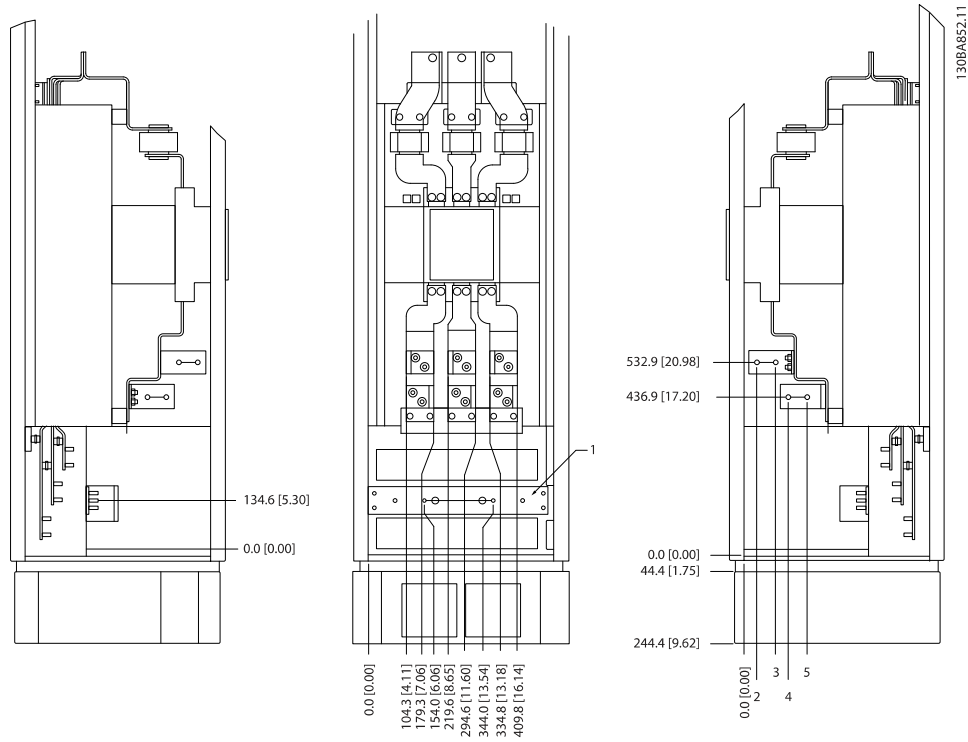

Illustration 4.25 Terminal locations - Options Cabinet with circuit breaker/ molded case switch (Left side, front and right side view). The gland plate is 42 mm below .0 level.

1) Ground bar

Power size	2	3	4	5
500 kW (480 V), 710-800 kW (690 V)	34.9	86.9	122.2	174.2
560-1000 kW (480 V), 900-1400 kW (690 V)	46.3	98.3	119.0	171.0

Table 4.2 Dimension for terminal



4.3.6 Cooling and Airflow

Cooling

Cooling can be obtained in different ways, by using the cooling ducts in the bottom and the top of the unit, by taking air in and out the back of the unit or by combining the cooling possibilities.

Duct cooling

A dedicated option has been developed to optimize installation of IP00/chassis drive types in Rittal TS8 Units utilizing the fan of the frequency converter for forced air cooling of the backchannel. Please consult GE for more details.

The air out the top of the Unit could be ducted outside a facility so the heat losses from the backchannel are not dissipated within the control room reducing air-conditioning requirements of the facility.

Please contact GE for more information.

Back cooling

The backchannel air can also be ventilated in and out the back of a Rittal TS8 Unit. This offers a solution where the backchannel could take air from outside the facility and

return the heat losses outside the facility thus reducing air-conditioning requirements.

CAUTION

A door fan(s) is required on the enclosure to remove the heat losses not contained in the backchannel of the drive and any additional losses generated from other components installed inside the enclosure. The total required air flow must be calculated so that the appropriate fans can be selected. Some enclosure manufacturers offer software for performing the calculations (i.e. Rittal Therm software). If the drive is the only heat generating component in the enclosure, the minimum airflow required at an ambient temperature of 45°C for the 43 and 44 unit size drives is 391 m³/h (230 cfm). The minimum airflow required at an ambient temperature of 45°C for the 52 drive is 782 m³/h (460 cfm).

Airflow

The necessary airflow over the heat sink must be secured. The flow rate is in *Table 4.3*.

Unit Size protection	Unit Size	Door fan(s) / Top fan airflow	Heatsink fan(s)
IP21 / NEMA 1 IP54 / NEMA 12	41 and 42	170 m ³ /h (100 cfm)	765 m ³ /h (450 cfm)
	51 350HP @ 460 V, 500 & 550 HP @ 690 V	340 m ³ /h (200 cfm)	1105 m ³ /h (650 cfm)
	51 450-550 HP @ 460V, 650-750 HP @ 690 V	340 m ³ /h (200 cfm)	1445 m ³ /h (850 cfm)
IP21 / NEMA 1	61, 62, 63 and 64	700 m ³ /h (412 cfm)*	985 m ³ /h (580 cfm)*
IP54 / NEMA 12	61, 62, 63 and 64	525 m ³ /h (309 cfm)*	985 m ³ /h (580 cfm)*
IP00 / Chassis	43 and 44	255 m ³ /h (150 cfm)	765 m ³ /h (450 cfm)
	52 350 HP @ 460V, 500 & 550 HP @ 690 V	255 m ³ /h (150 cfm)	1105 m ³ /h (650 cfm)
	52 450-550 HP @ 460V, 650-750 HP @ 690 V	255 m ³ /h (150 cfm)	1445 m ³ /h (850 cfm)

* Airflow per fan. Unit Sizes 5X contain multiple fans.

Table 4.3 Heatsink Air Flow

External ducts

If additional duct work is added externally to the Rittal cabinet the pressure drop in the ducting must be calculated. Use the charts below to derate the frequency converter according to the pressure drop.

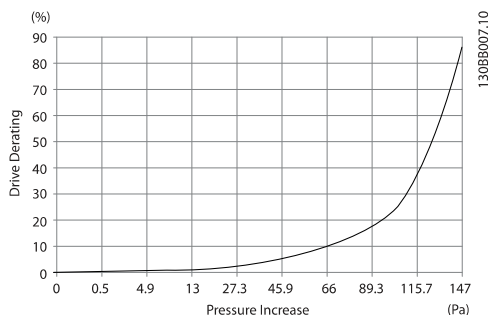

Illustration 4.26 Unit Size 4X Derating vs. Pressure Change
 Drive air flow: 450 cfm (765 m³/h)

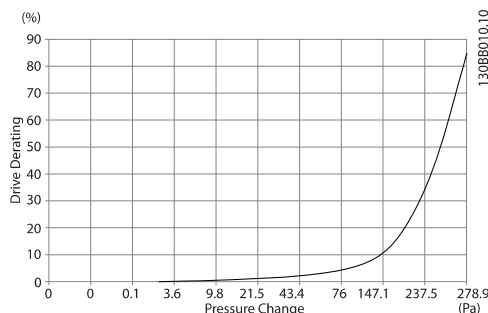

Illustration 4.27 Unit Size 5X Derating vs. Pressure Change (Small Fan), 350 HP @ 460V and 500-550 HP @ 690 V
 Drive air flow: 650 cfm (1105 m³/h)

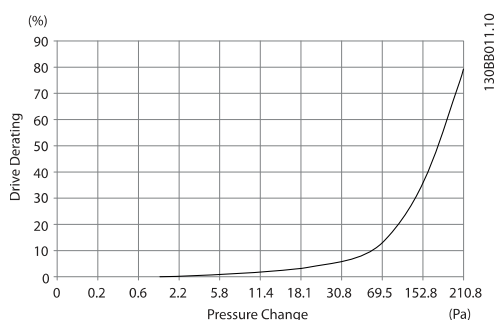

Illustration 4.28 Unit Size 5X Derating vs. Pressure Change (Large Fan)
 Drive air flow: 850 cfm (1445 m³/h)

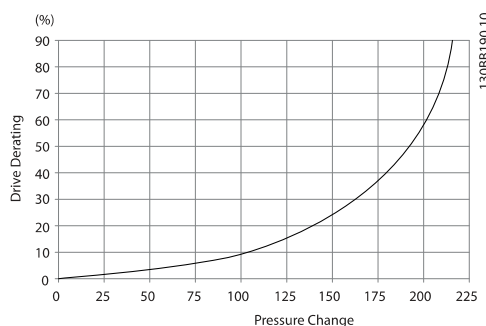

Illustration 4.29 Unit Size 61, 62, 63 and 64 Derating vs. Pressure Change

Drive air flow: 580 cfm (985 m³/h)

4.3.7 Installation on the Wall - IP21 (NEMA 1) and IP54 (NEMA 12) Units

This only applies to 41 and 42 Unit Sizes (460V, 125 - 300 HP, 575/600V, 125 - 400 HP). It must be considered where to install the unit.

Take the relevant points into consideration before you select the final installation site:

- Free space for cooling
- Access to open the door
- Cable entry from the bottom

Mark the mounting holes carefully using the mounting template on the wall and drill the holes as indicated. Ensure proper distance to the floor and the ceiling for cooling. A minimum of 225 mm (8.9 inch) below the frequency converter is needed. Mount the bolts at the bottom and lift the frequency converter up on the bolts. Tilt the frequency converter against the wall and mount the upper bolts. Tighten all four bolts to secure the frequency converter against the wall.

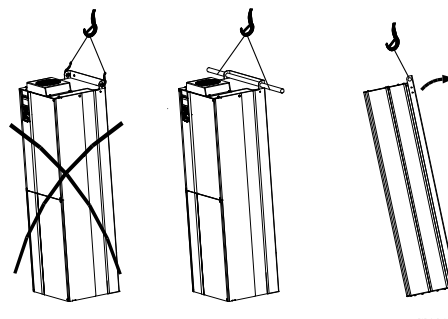

Illustration 4.30 Lifting method for mounting drive on wall

4.3.8 Gland/Conduit Entry - IP21 (NEMA 1) and IP54 (NEMA12)

Cables are connected through the gland plate from the bottom. Remove the plate and plan where to place the entry for the glands or conduits. Prepare holes in the marked area on the drawing.

NOTE

The gland plate must be fitted to the drive to ensure the specified protection degree, as well as ensuring proper cooling of the unit. If the gland plate is not mounted, the drive may trip on Alarm 69, Pwr. Card Temp

Cable entries viewed from the bottom of the drive - 1) Mains side 2) Motor side

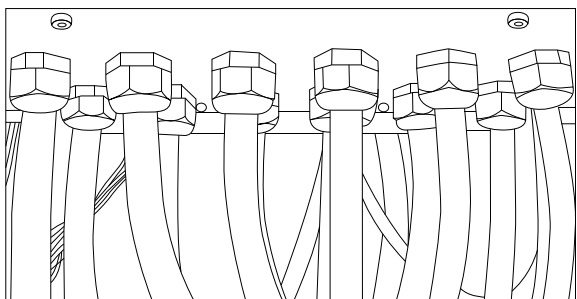

Illustration 4.31 Example of Proper Installation of Gland Plate.

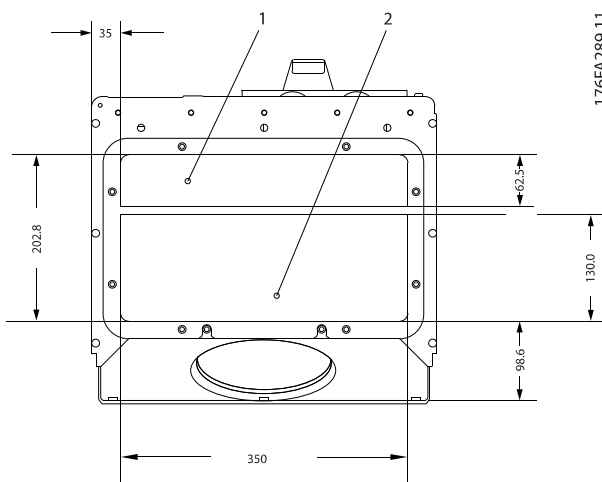

Illustration 4.32 Unit Sizes 41 + 42

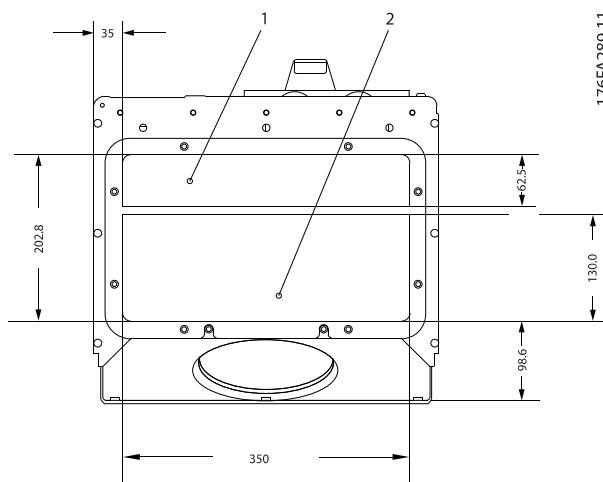

Illustration 4.33 Unit Size 51

Unit Size 61 to 64: Cable entries viewed from the bottom of the drive - 1) Place conduits in marked areas

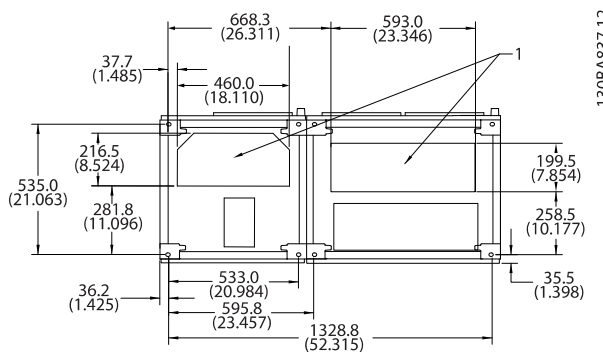

Illustration 4.34 Unit Size 61

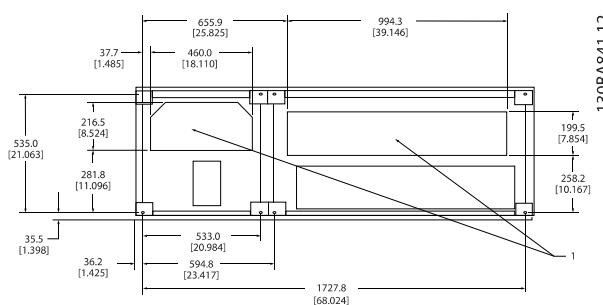

Illustration 4.35 Unit Size 62

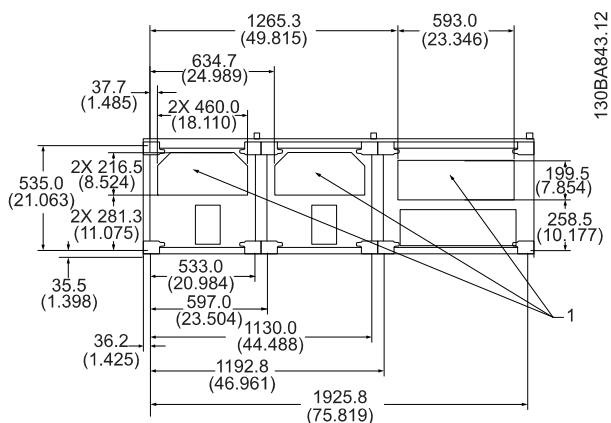

Illustration 4.36 Unit Size 63

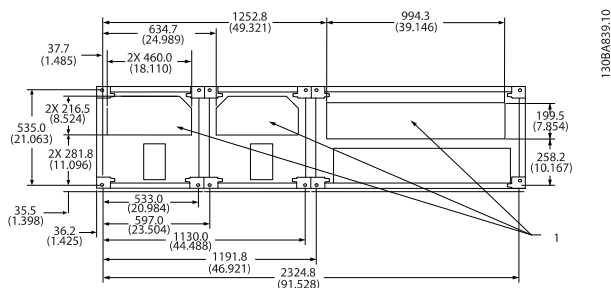

Illustration 4.37 Unit Size 64

4.3.9 IP21 Drip Shield Installation (Unit Sizes 41 and 42)

To comply with the IP21 rating, a separate drip shield is to be installed as explained below:

- Remove the two front screws
- Insert the drip shield and replace screws
- Torque the screws to 5,6 Nm (50 in-lbs)

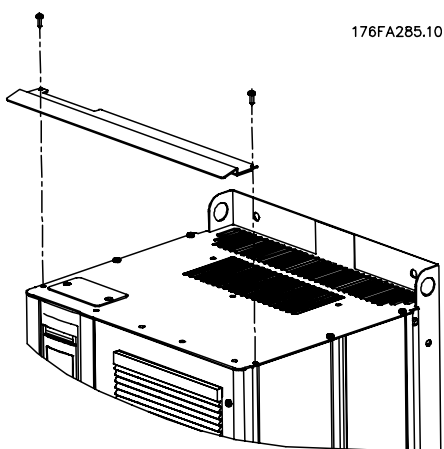

Illustration 4.38 Drip shield installation.

4.4 Field Installation of Options

4.4.1 Installation of Top-only Duct Cooling Kit

This description is for the installation of the top section only of the back-channel cooling kits available for unit sizes 43, 44 and 52. In addition to the enclosure a 200 mm vented pedestal is required.

The minimum enclosure depth is 500 mm (600 mm for unit size 52) and the minimum enclosure width is 600 mm (800 mm for unit size 52). The maximum depth and width are as required by the installation. When using multiple frequency converters in one enclosure mount each drive on its own back panel and support along the mid-section of the panel. The back-channel cooling kits are very similar in construction for all frames. The kits do not support "in frame" mounting of the frequency converters. The 52 kit is mounted "in frame" for additional support of the frequency converter.

Using these kits as described removes 85% of the losses via the back channel using the drive's main heat sink fan. The remaining 15% must be removed via the door of the enclosure.

Ordering information

Unit size 43 and 44: OPCDUCT4344T

Unit size 52: OPCDUCT52T

4.4.2 Installation of Top and Bottom Covers

Top and bottom covers can be installed on unit sizes 43, 44 and 52. These kits are designed to be used to direct the back-channel airflow in and out the back of the drive as opposed to in the bottom and out the top of the drive (when the drives are being mounted directly on a wall or inside a welded enclosure).

Notes:

1. If external duct work is added to the exhaust path of the drive, additional back pressure will be created that will reduce the cooling of the drive. The drive must be derated to accommodate the reduced cooling. First, the pressure drop must be calculated, then refer to the derating tables located earlier in this section.
2. A doorfan(s) is required on the enclosure to remove the heat losses not contained in the backchannel of the drive and any additional losses generated from other components installed inside the enclosure. The total required air flow must be calculated so that the appropriate fans can be selected. Some enclosure manufacturers



offer software for performing the calculations (i.e. Rittal Therm software).

If the frequency converter is the only heat generating component in the enclosure, the minimum airflow required at an ambient temperature of 45°C for the unit sizes 43, 44 and 52 drives is 391 m³/h (230 cfm). The minimum airflow required at an ambient temperature of 45°C for the 52 unit size drive is 782 m³/h (460 cfm).

Ordering information

Unit size 43 and 44: OPCDUCT4344TB

Unit size 52: OPCDUCT52TB

4.4.3 Outside Installation /NEMA 3R Kit of Industrial Enclosures

The kits are available for the unit sizes 43, 44 and 52. These kits are designed and tested to be used with IP00/ Chassis drives in welded box construction enclosures with an environmental rating of NEMA-3R or NEMA-4. The NEMA-3R enclosure is a dust tight, rain tight, ice resistant, outdoor enclosure. The NEMA-4 enclosure is a dust tight and water tight enclosure.

This kit has been tested and complies with UL environmental rating Type-3R.

Note: The current rating of 43 and 44 unit size drives are de-rated by 3% when installed in a NEMA- 3R enclosure. 52 unit size drives require no de-rating when installed in a NEMA-3R enclosure.

Ordering information

Unit size 43: OPCDUCT433R

Unit size 44: OPCDUCT443R

Unit size 52: OPCDUCT523R

4.4.4 Installation of IP00 to IP20 Kits

The kits can be installed on unit sizes 43, 44, and 52 (IP00).

Ordering information

Unit size 43/44: Please consult GE

Unit size 52: Please consult GE

4.4.5 Installation of cable clamp bracket in open chassis drives.

The motor cable clamp brackets can be installed on open chassis drives in unit sizes 43, 44, and 52.

Ordering information

Unit size 43: Please consult GE

Unit size 44: Please consult GE

Unit size 52: Please consult GE

4.4.6 Installation on Pedestal

This section describes the installation of a pedestal unit available for the frequency converters Unit Sizes 41 and 42. This is a 200 mm high pedestal that allows these Units to be floor mounted. The front of the pedestal has openings for input air to the power components.

The frequency converter gland plate must be installed to provide adequate cooling air to the control components of the frequency converter via the door fan and to maintain the IP21/NEMA 1 or IP54/NEMA 12 degrees of Unit protections.



175ZT976.10

Illustration 4.39 Drive on pedestal

There is one pedestal that fits both Unit Sizes 41 and 42. The pedestal is standard for Unit Size 51.

Ordering information

Unit size 41/42: OPC4XPED

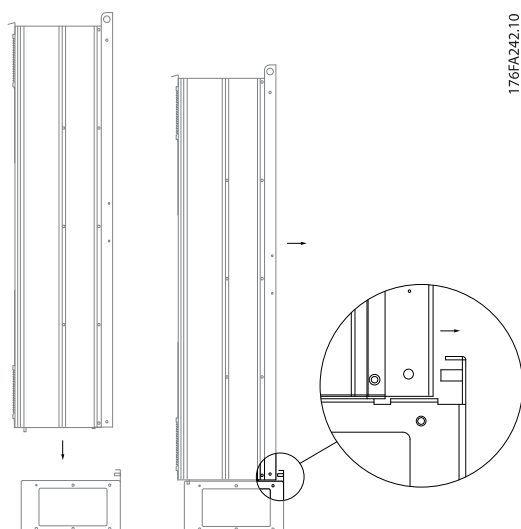

Illustration 4.40 Mounting of drive to pedestal.

4.4.7 Installation of Mains Shield for Frequency Converters

This section is for the installation of a mains shield for the frequency converter series with Unit Sizes 41, 42 and 51. It is not possible to install in the IP00/ Chassis drive types as these have included as standard a metal cover. These shields satisfy VBG-4 requirements.

NOTE

For further information, please consult GE.

4.4.8 Unit Size 6x USB Extension Kit

A USB extension cable can be installed into the door of unit size 6x frequency converters.

NOTE

For further information, please consult GE.

4.4.9 Installation of 4x or 5x Loadshare Option

The loadshare option can be installed on unit sizes 41, 42, 43, 44, 51 and 52.

Ordering information

Unit size 41/43: OPCLSK41

Unit size 42/44: OPCLSK42

Unit size 51/52: OPCLSK51 for 460 VAC

OPCLSK52 for 575 VAC



5 How to Operate the Frequency Converter

5.1.1 Two Ways of Operating

The frequency converter can be operated in two ways:

1. keypad
2. RS-485 serial communication or USB, both for PC connection

If the frequency converter is fitted with network option module, please refer to relevant documentation.

5.1.2 How to operate graphical keypad

The keypad is divided into four functional groups:

1. Graphical display with Status lines.
2. Menu keys and indicator lights (LEDs) - selecting mode, changing parameters and switching between display functions.
3. Navigation keys and indicator lights (LEDs).
4. Operation keys and indicator lights (LEDs).

Graphical display:

The LCD-display is back-lit with a total of 6 alpha-numeric lines. All data is displayed on the keypad which can show up to five operating variables while in [Status] mode.

Display lines:

- Status line:** Status messages displaying icons and graphics.
- Line 1-2:** Operator data lines displaying data and variables defined or chosen by the user. By pressing the [Status] key, up to one extra line can be added.
- Status line:** Status messages displaying text.

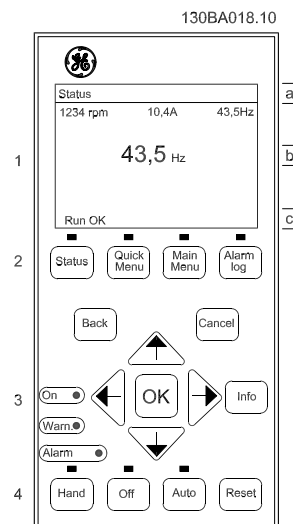

The display is divided into 3 sections:

Top section (a) shows the status when in status mode or up to 2 variables when not in status mode and in the case of Alarm/Warning.

The number of the Active Set-up (selected as the Active Set-up in *K-10 Active Set-up*) is shown. When programming in another Set-up than the Active Set-up, the number of the Set-up being programmed appears to the right in brackets.

The **Middle section (b)** shows up to 5 variables with related unit, regardless of status. In case of alarm/warning, the warning is shown instead of the variables.

The **Bottom section (c)** always shows the state of the frequency converter in Status mode.

It is possible to toggle between three status read-out displays by pressing the [Status] key.

Operating variables with different formatting are shown in each status screen - see below.

Each value / measurement readout parameter selected in *K-20 Display Line 1.1 Small* to *K-24 Display Line 3 Large* has its own scale and number of digits after a possible decimal point. Larger numeric values are displayed with few digits after the decimal point.

Ex.: Current readout
5.25 A; 15.2 A 105 A.



Status display I:

This read-out state is standard after start-up or restore. Use [INFO] to obtain information about the value/ measurement linked to the displayed operating variables (1.1, 1.2, 1.3, 2, and 3). See the operating variables shown in the display in this illustration. 1.1, 1.2 and 1.3 are shown in small size. 2 and 3 are shown in medium size.

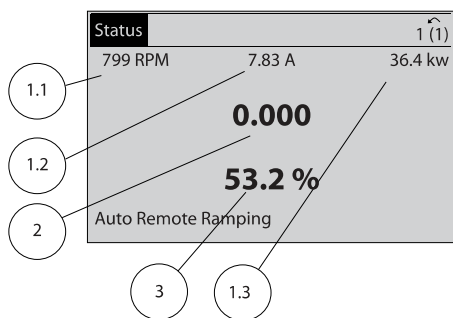

130BP041.10

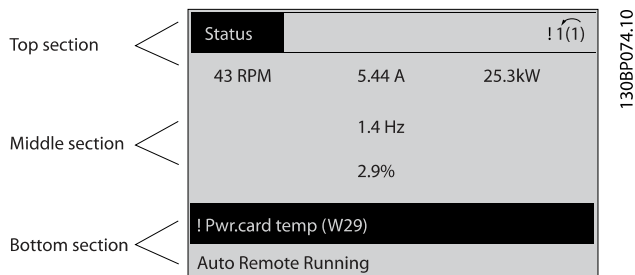

130BP074.10

Status display II:

See the operating variables (1.1, 1.2, 1.3, and 2) shown in the display in this illustration. In the example, Speed, Motor current, Motor power and Frequency are selected as variables in the first and second lines. 1.1, 1.2 and 1.3 are shown in small size. 2 is shown in large size.

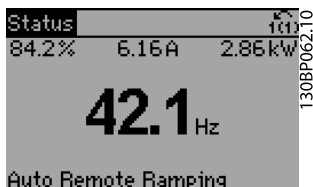

130BP062.10

Status display III:

This state displays the event and action of the Logic Controller. For further information, see section Logic Controller.

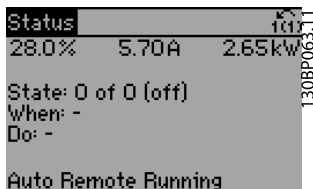

130BP063.11

Display Contrast Adjustment

Press [status] and [▲] for darker display
Press [status] and [▼] for brighter display

Indicator lights (LEDs):

If certain threshold values are exceeded, the alarm and/or warning LED lights up. A status and alarm text appear on the keypad. The On LED is activated when the frequency converter receives power from mains voltage, a DC bus terminal, or an external 24 V supply. At the same time, the back light is on.

- Green LED/On: Control section is working.
Yellow LED/Warn.: Indicates a warning.
Flashing Red LED/Alarm: Indicates an alarm.



130BP044.10

Keys

Menu keys

The menu keys are divided into functions. The keys below the display and indicator lamps are used for parameter set-up, including choice of display indication during normal operation.



130BP045.10

[Status]

indicates the status of the frequency converter and/or the motor. 3 different readouts can be chosen by pressing the [Status] key:
5 line readouts, 4 line readouts or Logic Controller.



Use **[Status]** for selecting the mode of display or for changing back to Display mode from either the Quick Menu mode, the Main Menu mode or Alarm mode. Also use the **[Status]** key to toggle single or double read-out mode.

[Quick Menu]

allows quick set-up of the frequency converter. **The most common AF-600 FP functions can be programmed here.**

The **[Quick Menu]** consists of:

- Quick Start
- Fan Macros
- Pump Macros
- Compressor Macros
- Closed Loop
- Parameter Data Check
- Trendings

The Function set-up provides quick and easy access to all parameters required for the majority of AF-600 FP applications including most VAV and CAV supply and return fans, cooling tower fans, Primary, Secondary and Condenser Water Pumps and other pump, fan and compressor applications. Amongst other features it also includes parameters for selecting which variables to display on the keypad, digital preset speeds, scaling of analog references, closed loop single zone and multi-zone applications and specific functions related to Fans, Pumps and Compressors.

The Quick Menu parameters can be accessed immediately unless a password has been created via *K-60 Main Menu Password*, *K-61 Access to Main Menu w/o Password*, *K-65 Quick Menu Password* or *K-66 Access to Quick Menu w/o Password*.

It is possible to switch directly between Quick Menu mode and Main Menu mode.

[Main Menu]

is used for programming all parameters. The Main Menu parameters can be accessed immediately unless a password has been created via *K-60 Main Menu Password*, *K-61 Access to Main Menu w/o Password*, *K-65 Quick Menu Password* or *K-66 Access to Quick Menu w/o Password*. For the majority of AF-600 FP applications it is not necessary to access the Main Menu parameters but instead the Quick Menu, Quick Set-up and Function Set-up provides the simplest and quickest access to the typical required parameters.

It is possible to switch directly between Main Menu mode and Quick Menu mode.

Parameter shortcut can be carried out by pressing down the **[Main Menu]** key for 3 seconds. The parameter shortcut allows direct access to any parameter.

[Alarm Log]

displays an Alarm list of the ten latest alarms (numbered A1-A10). To obtain additional details about an alarm, use the arrow keys to manoeuvre to the alarm number and press **[OK]**. Information is displayed about the condition of the frequency converter before it enters the alarm mode.

The Alarm log button on the keypad allows access to both Alarm log and Maintenance log.

[Back]

reverts to the previous step or layer in the navigation structure.

[Cancel]

last change or command will be cancelled as long as the display has not been changed.

[Info]

displays information about a command, parameter, or function in any display window. **[Info]** provides detailed information when needed.

Exit Info mode by pressing either **[Info]**, **[Back]**, or **[Cancel]**.

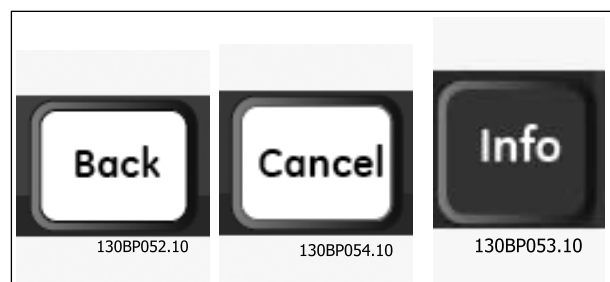

Navigation Keys

The four navigation arrows are used to navigate between the different choices available in **[Quick Menu]**, **[Main Menu]** and **[Alarm Log]**. Use the keys to move the cursor.

[OK] is used for choosing a parameter marked by the cursor and for enabling the change of a parameter.

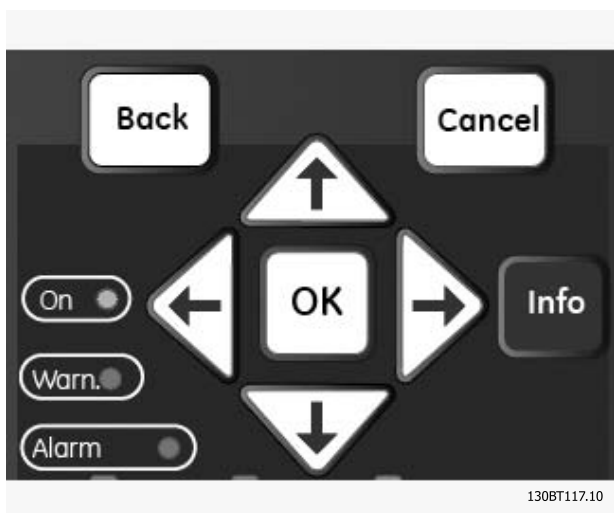

Operation Keys for local control are found at the bottom of the keypad.

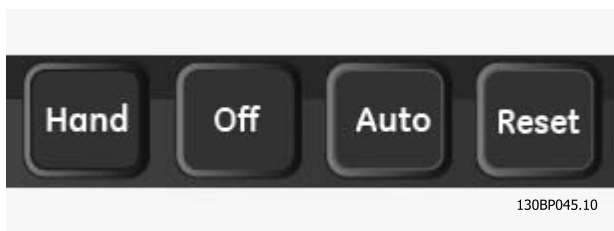

[Hand]

enables control of the frequency converter via the keypad. [Hand] also starts the motor, and it is now possible to enter the motor speed data by means of the arrow keys. The key can be selected as *Enable* [1] or *Disable* [0] via *K-40 [Hand] Button on Keypad*.

The following control signals will still be active when [Hand] is activated:

- [Hand] - [Off] - [Auto]
- Reset
- Coasting stop inverse
- Reversing
- Set-up select lsb - Set-up select msb
- Stop command from serial communication
- Quick stop
- DC brake

NOTE

External stop signals activated by means of control signals or a serial bus will override a "start" command via the keypad.

[Off]

stops the connected motor. The key can be selected as *Enable* [1] or *Disable* [0] via *K-41 [Off] Button on Keypad*. If no external stop function is selected and the [Off] key is inactive the motor can only be stopped by disconnecting the mains supply.

[Auto]

enables the frequency converter to be controlled via the control terminals and/or serial communication. When a start signal is applied on the control terminals and/or the bus, the frequency converter will start. The key can be selected as *Enable* [1] or *Disable* [0] via *K-42 [Auto] Button on Keypad*.

NOTE

An active **HAND-OFF-AUTO** signal via the digital inputs has higher priority than the control keys [Hand] – [Auto].

[Reset]

is used for resetting the frequency converter after an alarm (trip). It can be selected as *Enable* [1] or *Disable* [0] via *K-43 [Reset] Button on Keypad*.

The parameter shortcut can be carried out by holding down the [Main Menu] key for 3 seconds. The parameter shortcut allows direct access to any parameter.

5.1.3 RS-485 Bus Connection

One or more frequency converters can be connected to a controller (or master) using the RS-485 standard interface. Terminal 68 is connected to the P signal (TX+, RX+), while terminal 69 is connected to the N signal (TX-,RX-).

If more than one frequency converter is connected to a master, use parallel connections.

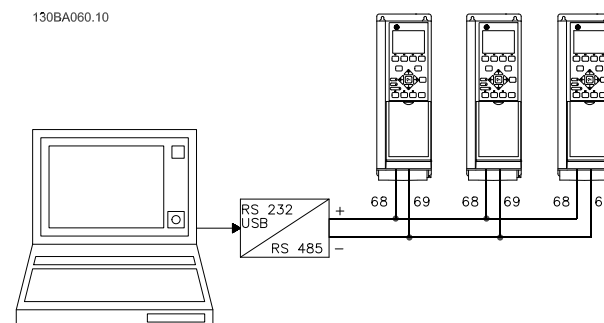

Illustration 5.1 Connection example.

In order to avoid potential equalizing currents in the screen, earth the cable screen via terminal 61, which is connected to the frame via an RC-link.

Bus termination

The RS-485 bus must be terminated by a resistor network at both ends. If the drive is the first or the last device in the RS-485 loop, set the switch S801 on the control card for ON.

For more information, see the paragraph *Switches S201, S202, and S801*.

5.1.4 How to Connect a PC to the Drive

NOTE

The USB connection is galvanically isolated from the supply voltage (PELV) and other high-voltage terminals. The USB connection is connected to protection earth on the drive. Use only an isolated laptop as PC connection to the USB connector on the drive.

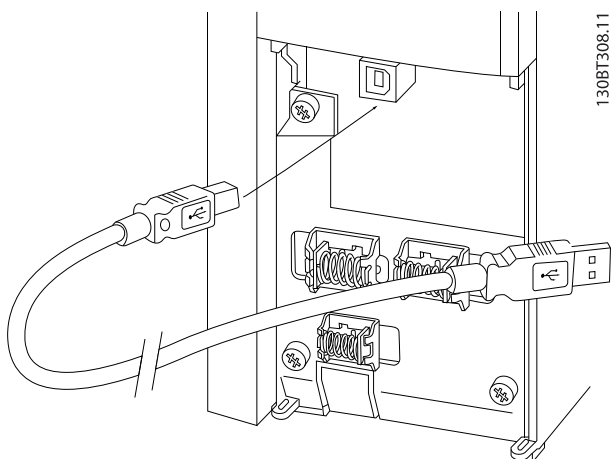

Illustration 5.2 For control cable connections, see section on Control Terminals.

5.1.5 PC Software Tools

PC-based Drive Control Tool DCT 10

All Frequency converters are equipped with a serial communication port. GE provides a PC tool for communication between PC and frequency converter, PC-based Drive Control Tool DCT 10. Please check the section on *Available Literature* for detailed information on this tool.

Drive Control Tool DCT 10

DCT 10 has been designed as an easy to use interactive tool for setting parameters in our frequency converters. The DCT 10 Drive Control Tool will be useful for:

- Planning a communication network off-line. DCT 10 contains a complete frequency converter database
- Commissioning frequency converters on line
- Saving settings for all frequency converters

- Replacing a frequency converter in a network
- Simple and accurate documentation of frequency converter settings after commissioning.
- Expanding an existing network
- Future developed frequency converters will be supported

Drive Control Tool DCT 10 software supports Profibus DP-V1 via a Master class 2 connection. It makes it possible to on line read/write parameters in a frequency converter via the Profibus network. This will eliminate the need for an extra communication network.

Save frequency converter settings:

1. Connect a PC to the unit via USB com port. (NOTE: Use a PC, which is isolated from the mains, in conjunction with the USB port. Failure to do so may damage equipment.)
2. Open Drives Control Tool DCT 10 Software
3. Choose "Read from drive"
4. Choose "Save as"

All parameters are now stored in the PC.

Load frequency converter settings:

1. Connect a PC to the frequency converter via USB com port
2. Open Drives Control Tool DCT 10 software
3. Choose "Open"– stored files will be shown
4. Open the appropriate file
5. Choose "Write to drive"

All parameter settings are now transferred to the frequency converter.

A separate manual for Drives Control Tool DCT 10 Software is available from GE or the web: www.geelectrical.com/drives.

5.1.6 Tips and Tricks

- For the majority of HVAC applications the Quick Menu, Quick Set-up and Macros Set-up provides the simplest and quickest access to all the typical parameters required
- Whenever possible, performing an auto tuning, will ensure best shaft performance
- Contrast of the display can be adjusted by pressing [Status] and [▲] for darker display or by pressing [Status] and [▼] for brighter display
- Under [Quick Menu] and [Parameter Data Check] all parameters that have been changed from factory settings are displayed



- Press and hold [Main Menu] key for 3 seconds for access to any parameter
 - For service purposes it is recommended to copy all parameters to the keypad, see *K-50 Keypad Copy* for further information
5. Remove power to unit and wait for display to turn off.
 6. Reconnect power and the frequency converter is reset. Note that first start-up takes a few more seconds
 7. Press [Reset]

5.1.7 Quick Transfer of Parameter Settings when using Keypad

Once the set-up of a frequency converter is complete, it is recommended to store (backup) the parameter settings in the or on a PC via DCT 10 software.

⚠ WARNING

Stop the motor before performing any of these operations.

Data storage in keypad:

1. Go to *K-50 Keypad Copy*
2. Press the [OK] key
3. Select "All to keypad"
4. Press the [OK] key

All parameter settings are now stored in the keypad indicated by the progress bar. When 100% is reached, press [OK].

The keypad can now be connected to another frequency converter and the parameter settings copied to this frequency converter.

Data transfer from keypad to Frequency converter:

1. Go to *K-50 Keypad Copy*
2. Press the [OK] key
3. Select "All from keypad"
4. Press the [OK] key

The parameter settings stored in the graphical keypad are now transferred to the frequency converter indicated by the progress bar. When 100% is reached, press [OK].

5.1.8 Restore Factory Settings

There are two ways to restore the drive to factory settings: Recommended restore and manual restore.

Please be aware that they have different impact according to the below description.

Recommended restore (via *H-03 Restore Factory Settings*)

1. Select *H-03 Restore Factory Settings*
2. Press [OK]
3. Select [2] Restore Factory Settings
4. Press [OK]

H-03 Restore Factory Settings restores all except:

SP-50 RFI Filter

O-30 Protocol

O-31 Address

O-32 Drive Port Baud Rate

O-35 Minimum Response Delay

O-36 Max Response Delay

O-37 Maximum Inter-Char Delay

ID-00 Operating Hours to *ID-05 Over Volt's*

ID-20 Historic Log: Event to *ID-22 Historic Log: Time*

ID-30 Alarm Log: Error Code to *ID-32 Alarm Log: Time*

Manual restore

NOTE

When carrying out manual restore, serial communication, RFI filter settings and fault log settings are reset.

1. Disconnect from mains and wait until the display turns off.

2a. Press [Status] - [Main Menu] - [OK] at the same time while power up for keypad

3. Release the keys after 5 sec.

4. The frequency converter is now programmed according to default settings

The Manual Restore restores all except:

ID-00 Operating Hours

ID-03 Power Up's

ID-04 Over Temp's

ID-05 Over Volt's



6 How to Program

6.1 How to Program

6.1.1 Parameter Set-Up

Group	Title	Function
K-##	Operation and Display	Parameters used to program the keypad including: selection of language; selection of which variables are displayed at each position in the display (e.g. static duct pressure or condenser water return temperature can be displayed with the setpoint in small digits in the top row and feedback in large digits in the centre of the display); enabling/disabling of the keypad keys/buttons; passwords for the keypad; upload and download of commissioned parameters to/from the keypad and setting the built in clock.
F-##	Fundamental Parameters	Parameters used to configure the basic setup of the drive, including basic accel/decel times, frequency and speed limits, maximum and minimum reference etc.
E-##	Digital In / Out	Parameters used to program the functions of all digital inputs, digital outputs, relay outputs, pulse inputs and pulse outputs for terminals on the control card and all option cards.
C-##	Frequency Control Functions	Parameters used to configure drive frequency settings, including jump frequencies and jog speed.
P-##	Load / Motor	Parameters used to configure the frequency converter for the specific application and motor including: open or closed loop operation; type of application such as compressor, fan or centrifugal pump; motor nameplate data; auto-tuning of the drive to the motor for optimum performance; flying start (typically used for fan applications) and motor thermal protection.
H-##	High Perf Parameters	Parameters used to configure additional drive functions. Infrequently used parameters can be found here.
AN-##	Analog In / Out	Parameters used to program the functions associated with all analog inputs and analog outputs for the terminals on the control card and General Purpose I/O option (OPCGPIO) (note: For Analog I/O option OPCALIO, see parameter group AO-00) including: analog input live zero timeout function (which for example can be used to command a cooling tower fan to operate at full speed if the condenser water return sensor fails); scaling of the analog input signals (for example to match the analog input to the mA and pressure range of a static duct pressure sensor); filter time constant to filter out electrical noise on the analog signal which can sometimes occur when long cables are installed; function and scaling of the analog outputs (for example to provide an analog output representing motor current or kW to an analog input of a DDC controller) and to configure the analog outputs to be controlled by the BMS via a high level interface (HLI) (e.g. to control a chilled water valve) including ability to define a default value of these outputs in the event of the HLI failing.
SP-##	Special Functions	Parameters used to configure special functions of the frequency converter including: kinetic back-up function (especially useful for critical applications in semi-conductor installations where performance under mains dip/mains loss is important); mains imbalance protection; automatic reset (to avoid the need for a manual reset of Alarms); energy optimisation parameters (which typically do not need changing but enable fine tuning of this automatic function (if necessary) ensuring the frequency converter and motor combination operate at their optimum efficiency at full and partial load conditions) and auto-derating functions (which enable the frequency converter to continue operation at reduced performance under extreme operating conditions ensuring maximum up time).
O-##	Communication and Options	Parameters used for configuring and monitoring functions associated with the serial communications / high level interface to the frequency converter
AO-##	Analog I/O Option	Parameters used to configure the Analog I/O option (OPCALIO) including: definition of the analog input types (e.g. voltage, Pt1000 or Ni1000) and scaling and definition of the analog output functions and scaling.
DN-##	DeviceNet	Parameters only applicable when a DeviceNet option is installed.
PB-##	Profibus	Parameters only applicable when a Profibus option is installed.



How to Program

AF-600 FP High Power Operating Instructions

6

Group	Title	Function
LN-##	LonWorks	Parameters only applicable when a Lonworks option is installed.
BN-##	BACnet	Parameters used for BACnet configuration.
ID-##	Drive Information	Parameters providing operating data and other drive information including: operating and running hour counters; kWh counter; resetting of the running and kWh counters; alarm/fault log (where the past 10 alarms are logged along with any associated value and time) and drive and option card identification parameters such as code number and software version.
DR-##	Data Readouts	Read only parameters which display the status/value of many operating variables which can be displayed on the keypad or viewed in this parameter group. These parameters can be particularly useful during commissioning when interfacing with a BMS via a high level interface.
LG-##	Logs & I/O Opt. Status	Read only parameters which display the last 10 preventative maintenance log items, actions and time and the value of analog inputs and outputs on the Analog I/O option card which can be particularly useful during commissioning when interfacing with a BMS via a high level interface.
AP-##	HVAC Appl. Param.	Parameters used to monitor, protect and control pumps, fans and compressors including: no flow detection and protection of pumps (including auto-setup of this function); dry pump protection; end of curve detection and protection of pumps; sleep mode (especially useful for cooling tower and booster pump sets); broken belt detection (typically used for fan applications to detect no air flow instead of using a Δp switch installed across the fan); short cycle protection of compressors and pump flow compensation of setpoint (especially useful for secondary chilled water pump applications where the Δp sensor has been installed close to the pump and not across the furthest most significant load(s) in the system; using this function can compensate for the sensor installation and help to realise the maximum energy savings).
FB-##	Fire/Bypass Operation	Parameters used to set-up Fire Mode and/or to control a bypass contactor/starter if designed into the system.
T-##	Timed Functions	Time based parameters including: those used to initiate daily or weekly actions based on the built in real time clock (e.g. change of setpoint for night set back mode or start/stop of the pump/fan/compressor start/stop of a external equipment); preventative maintenance functions which can be based on running or operating hour time intervals or on specific dates and times; energy log (especially useful in retrofit applications or where information of the actual historical load (kW) on the pump/fan/compressor is of interest); trending (especially useful in retrofit or other applications where there is an interest to log operating power, current, frequency or speed of the pump/fan/compressor for analysis and a payback counter.
CL-##	PID Closed Loop	Parameters used to configure the closed loop PI(D) controller which controls the speed of the pump, fan or compressor in closed loop mode including: defining where each of the 3 possible feedback signals come from (e.g. which analog input or the BMS HLI); conversion factor for each of the feedback signals (e.g. where a pressure signal is used for indication of flow in an AHU or converting from pressure to temperature in a compressor application); engineering unit for the reference and feedback (e.g. Pa, kPa, m Wg, in Wg, bar, m ³ /s, m ³ /h, °C, °F etc); the function (e.g. sum, difference, average, minimum or maximum) used to calculate the resulting feedback for single zone applications or the control philosophy for multi-zone applications; programming of the setpoint(s) and manual or auto-tuning of the PI(D) loop.
XC-##	Ext. PID Closed Loop	Parameters used to configure the 3 extended closed loop PI(D) controllers which for example can be used to control external actuators (e.g. chilled water valve to maintain supply air temperature in a VAV system) including: engineering unit for the reference and feedback of each controller (e.g. °C, °F etc); defining the range of the reference/setpoint for each controller; defining where each of the references/setpoints and feedback signals come from (e.g. which analog input or the BMS HLI); programming of the setpoint and manual or auto-tuning of the each of the PI(D) controllers.
PC-##	Pump Controller	Parameters used to configure and monitor the built in pump controller (typically used for pump booster sets).



Group	Title	Function
LC-##	Logic Controller	Parameters used to configure the built in Logic Controller (LC) which can be used for simple functions such as comparators (e.g. if running above xHz, activate output relay), timers (e.g. when a start signal is applied, first activate output relay to open supply air damper and wait x seconds before accelng) or a more complex sequence of user defined actions executed by the LC when the associated user defined event is evaluated as TRUE by the LC. (For example, initiate an economiser mode in a simple AHU cooling application control scheme where there is no BMS. For such an application the LC can monitor the outside air relative humidity and if it is below a defined value, the supply air temperature setpoint could be automatically increased. With the frequency converter monitoring the outside air relative humidity and supply air temperature via it's analog inputs and controlling the chilled water valve via one of the extended PI(D) loops and an analog output, it would then modulate that valve to maintain a higher supply air temperature). The LC can often replace the need for other external control equipment.
B-##	Brakes	Parameters used to configure braking functions of the frequency converter which although not common in many AF-600 FP applications, can be useful on special fan applications. Parameters including: DC braking and over voltage control (which provides automatic adjustment of the deceleration rate (auto-ramping) to avoid tripping when decelerating large inertia fans)

Table 6.1 Parameter Groups

Parameter descriptions and selections are displayed on the keypad display. (See relevant section for details.) Access the parameters by pressing the [Quick Menu] or [Main Menu] button on the keypad. The Quick Menu is used primarily for commissioning the unit at start-up by providing the parameters necessary to start operation. The Main Menu provides access to all parameters for detailed application programming.

All digital input/output and analog input/output terminals are multifunctional. All terminals have factory default functions suitable for the majority of AF-600 FP applications but if other special functions are required, they must be programmed as explained in parameter group E-## or AN-##.



6.1.2 Quick Menu Mode

Parameter Data

The keypad provides access to all parameters listed under the Quick Menus. To set parameters using the [Quick Menu] button - enter or change parameter data or settings in accordance with the following procedure:

1. Press Quick Menu button then press Quick Start
2. Use the [▲] and [▼] buttons to find the parameter you want to change
3. Press [OK]
4. Use [▲] and [▼] buttons to select the correct parameter setting
5. Press [OK]
6. To move to a different digit within a parameter setting, use the [◀] and [▶] buttons
7. Highlighted area indicates digit selected for change
8. Press [Cancel] button to disregard change, or press [OK] to accept change and enter the new setting

Example of changing parameter data

Assume parameter F-07 Accel Time 1 is set to 6 seconds and you want to change it to 10 seconds. Use the following procedure:

1. Press Quick Menu key
2. Choose Quick Start
3. Press [OK]
4. With the [▼] button find par. F-07 Accel Time 1
5. Press [OK]
6. Use the arrow keys to change the 6.00 to 10.00.
7. Press [OK]

The drive will now accelerate to rated speed in 10 seconds instead of 6 seconds.

It is recommended to do the set-up in the order that the parameters are listed!

Select [Parameter Data Check] to get information about:

- The last 10 changes. Use the up/down navigation keys to scroll between the last 10 changed parameters.
- The changes made since default setting.

Select [Trendings]:

to get information about the display line read-outs. The information is shown as graphs.

Only display parameters selected in *K-20 Display Line 1.1 Small* and *K-24 Display Line 3 Large* can be viewed. It is possible to store up to 120 samples in the memory for later reference.

Efficient Parameter Set-up for AF-600 FP Applications:

The parameters can easily be set up for the vast majority of the AF-600 FP applications only by using the [Quick Setup] option.

After pressing [Quick Menu], the different choices in the Quick Menu are listed.

Example of using the Quick Setup option:

NOTE

A complete description of the function is found in the parameter sections of this manual.

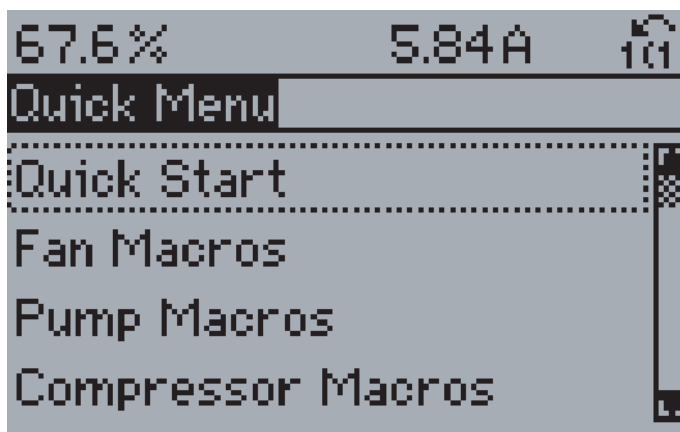

130BP064.10

Illustration 6.1 Quick Menu view.

The Quick Setup menu gives access to the most important setup parameters of the frequency converter. After programming the frequency converter will, in most cases, be ready for operation. The Quick Setup parameters are shown in the table below. A complete description of the function is given in the parameter description sections of this manual.



Parameter	[Units]
K-01 Language	
K-02 Motor Speed Unit	
P-02 Motor Power [HP]*	[HP]
P-07 Motor Power [kW]	[kW]
F-05 Motor Rated Voltage	[V]
F-04 Base Frequency	[Hz]
P-03 Motor Current	[A]
P-06 Base Speed	[RPM]
F-01 Frequency Setting 1	
F-02 Operation Method	
F-07 Accel Time 1	[s]
F-08 Decel Time 1	[s]
F-10 Electronic Overload	
F-15 Motor Speed High Limit [Hz]*	[Hz]
F-16 Motor Speed Low Limit [Hz]*	[Hz]
F-17 Motor Speed High Limit [RPM]	[RPM]
F-18 Motor Speed Low Limit [RPM]	[RPM]
H-08 Reverse Lock	
P-04 Auto Tune	

Table 6.2 Quick Setup parameters

*The display showing depends on choices made in K-02 Motor Speed Unit and K-03 Regional Settings. The default settings of K-02 Motor Speed Unit and K-03 Regional Settings depend on which region of the world the frequency converter is supplied to but can be re-programmed as required.



6.1.3 Macros

The Macros provide quick and easy access to all parameters required for the majority of AF-600 FP applications including most VAV and CAV supply and return fans, cooling tower fans, Primary, Secondary and Condenser Water Pumps and other pump, fan and compressor applications.

How to access Macros - example

6

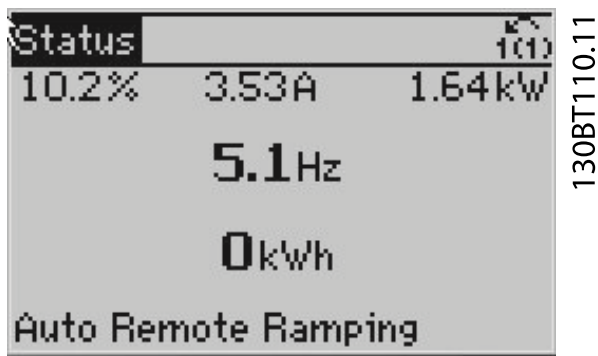

Illustration 6.2 Step 1: Turn on the frequency converter (green LED lights)



Illustration 6.5 Step 4: Use the up/down navigation keys to scroll down to find AP-62 Broken Belt Delay.

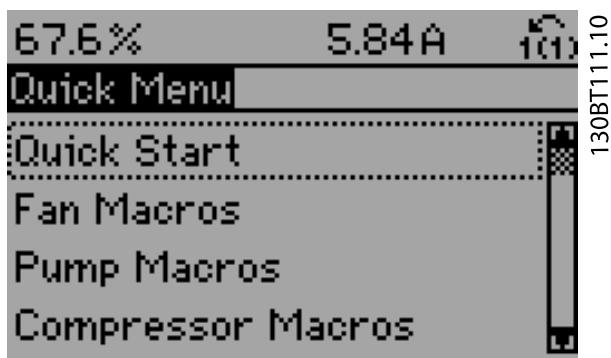

Illustration 6.3 Step 2: Press the [Quick Menus] button (Quick Menu choices appear).

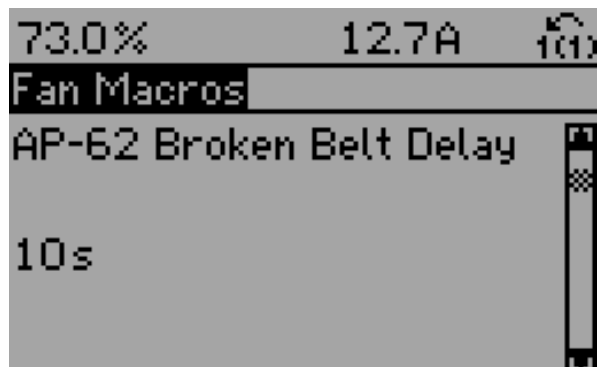

Illustration 6.6 Step 5: Press [OK].

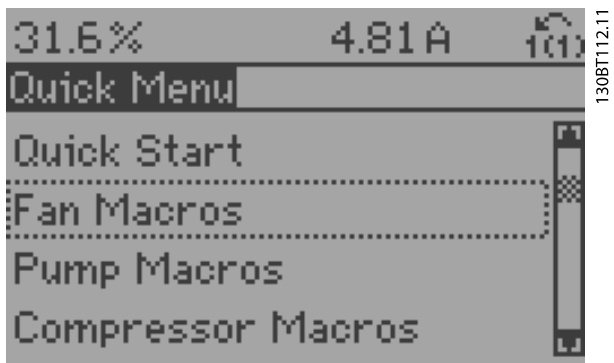

Illustration 6.4 Step 3: Use the up/down navigation keys to scroll down to Fan Macros. Press [OK].

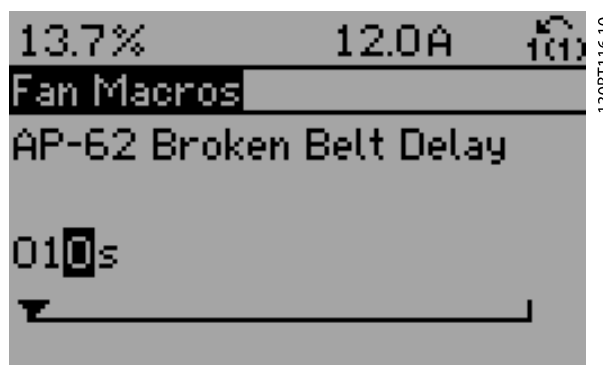

Illustration 6.7 Step 6: Use the up/down navigation keys to change the delay time.



Function Set-ups parameters

The Quick Menu parameters are grouped in the following way:

Application Settings		
Fan Macros	Pump Macros	Compressor Macros
AP-60 Broken Belt Function	AP-20 Low Power Auto Set-up	H-43 Torque Characteristics
AP-61 Broken Belt Torque	AP-21 Low Power Detection	F-24 Holding Time
AP-62 Broken Belt Delay	AP-22 Low Speed Detection	AP-75 Short Cycle Protection
C-40 Semi-Auto Jump Freq Set-up	AP-23 No-Flow Function	AP-76 Interval between Starts
H-43 Torque Characteristics	AP-24 No-Flow Delay	AP-77 Minimum Run Time
AP-22 Low Speed Detection	AP-40 Minimum Run Time	E-51 Terminal 27 Mode
AP-23 No-Flow Function	AP-41 Minimum Sleep Time	E-52 Terminal 29 Mode
AP-24 No-Flow Delay	AP-42 Wake-up Speed [RPM]	E-03 Terminal 27 Digital Input
AP-40 Minimum Run Time	AP-43 Wake-up Speed [Hz]	E-04 Terminal 29 Digital Input
AP-41 Minimum Sleep Time	AP-44 Wake-up Ref./FB Difference	E-24 Function Relay
AP-42 Wake-up Speed [RPM]	AP-45 Setpoint Boost	H-09 Start Mode
AP-43 Wake-up Speed [Hz]	AP-46 Maximum Boost Time	H-36 Trip Speed Low [RPM]
AP-44 Wake-up Ref./FB Difference	AP-26 Dry Pump Function	H-37 Trip Speed Low [Hz]
AP-45 Setpoint Boost	AP-27 Dry Pump Delay	
AP-46 Maximum Boost Time	AP-80 Flow Compensation	
B-10 Brake Function	AP-81 Square-linear Curve Approximation	
B-16 AC brake Max. Current	AP-82 Work Point Calculation	
B-17 Over-voltage Control	AP-83 Speed at No-Flow [RPM]	
H-09 Start Mode	AP-84 Speed at No-Flow [Hz]	
F-24 Holding Time	AP-85 Speed at Design Point [RPM]	
H-80 Function at Stop	AP-86 Speed at Design Point [Hz]	
B-00 DC Hold Current	AP-87 Pressure at No-Flow Speed	
H-08 Reverse Lock	AP-88 Pressure at Rated Speed	
	AP-89 Flow at Design Point	
	AP-90 Flow at Rated Speed	
	H-43 Torque Characteristics	
	H-09 Start Mode	



How to Program

AF-600 FP High Power Operating Instructions

6

Closed Loop Settings		
Single Zone Int. Set Point	Single Zone Ext. Set Point	Multi Zone / Adv
H-40 Configuration Mode	H-40 Configuration Mode	H-40 Configuration Mode
CL-12 Reference/Feedback Unit	CL-12 Reference/Feedback Unit	F-01 Frequency Setting 1
CL-13 Minimum Reference/Feedb.	CL-13 Minimum Reference/Feedb.	C-30 Frequency Command 2
CL-14 Maximum Reference/Feedb.	CL-14 Maximum Reference/Feedb.	CL-00 Feedback 1 Source
AN-22 Terminal 54 Low Current	AN-10 Terminal 53 Low Voltage	CL-01 Feedback 1 Conversion
AN-24 Terminal 54 Low Ref./Feedb. Value	AN-11 Terminal 53 High Voltage	CL-02 Feedback 1 Source Unit
AN-25 Terminal 54 High Ref./Feedb. Value	AN-12 Terminal 53 Low Current	CL-03 Feedback 2 Source
AN-26 Terminal 54 Filter Time Constant	AN-13 Terminal 53 High Current	CL-04 Feedback 2 Conversion
AN-27 Terminal 54 Live Zero	AN-14 Terminal 53 Low Ref./Feedb. Value	CL-05 Feedback 2 Source Unit
AN-00 Live Zero Timeout Time	AN-15 Terminal 53 High Ref./Feedb. Value	CL-06 Feedback 3 Source
AN-01 Live Zero Timeout Function	AN-22 Terminal 54 Low Current	CL-07 Feedback 3 Conversion
CL-21 Setpoint 1	AN-24 Terminal 54 Low Ref./Feedb. Value	CL-08 Feedback 3 Source Unit
CL-81 PID Normal/ Inverse Control	AN-25 Terminal 54 High Ref./Feedb. Value	CL-12 Reference/Feedback Unit
CL-82 PID Start Speed [RPM]	AN-26 Terminal 54 Filter Time Constant	CL-13 Minimum Reference/Feedb.
CL-83 PID Start Speed [Hz]	AN-27 Terminal 54 Live Zero	CL-14 Maximum Reference/Feedb.
CL-93 PID Proportional Gain	AN-00 Live Zero Timeout Time	AN-10 Terminal 53 Low Voltage
CL-94 PID Integral Time	AN-01 Live Zero Timeout Function	AN-11 Terminal 53 High Voltage
	CL-81 PID Normal/ Inverse Control	AN-12 Terminal 53 Low Current
	CL-82 PID Start Speed [RPM]	AN-13 Terminal 53 High Current
	CL-83 PID Start Speed [Hz]	AN-14 Terminal 53 Low Ref./Feedb. Value
	CL-93 PID Proportional Gain	AN-15 Terminal 53 High Ref./Feedb. Value
	CL-94 PID Integral Time	AN-16 Terminal 53 Filter Time Constant
		AN-17 Terminal 53 Live Zero
		AN-20 Terminal 54 Low Voltage
		AN-21 Terminal 54 High Voltage
		AN-22 Terminal 54 Low Current
		AN-23 Terminal 54 High Current
		AN-24 Terminal 54 Low Ref./Feedb. Value
		AN-25 Terminal 54 High Ref./Feedb. Value
		AN-26 Terminal 54 Filter Time Constant
		AN-27 Terminal 54 Live Zero
		AN-00 Live Zero Timeout Time
		AN-01 Live Zero Timeout Function
		H-76 Warning Feedback Low
		H-77 Warning Feedback High
		CL-20 Feedback Function
		CL-21 Setpoint 1
		CL-22 Setpoint 2
		CL-81 PID Normal/ Inverse Control
		CL-82 PID Start Speed [RPM]
		CL-83 PID Start Speed [Hz]
		CL-93 PID Proportional Gain
		CL-94 PID Integral Time
		CL-70 Closed Loop Type
		CL-71 PID Performance
		CL-72 PID Output Change
		CL-73 Minimum Feedback Level
		CL-74 Maximum Feedback Level
		CL-79 PID Autotuning



6.1.4 Main Menu Mode

The keypad provides access to the main menu mode. Select the Main Menu mode by pressing the [Main Menu] key. Illustration 6.2 shows the resulting read-out, which appears on the display of the keypad. Lines 2 through 5 on the display show a list of parameter groups which can be chosen by toggling the up and down buttons.

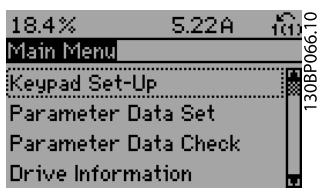

Illustration 6.8 Display example.

Each parameter has character(s) and number which remain the same regardless of the programming mode. In the Main Menu mode, the parameters are further divided into groups: Macros, Keypad Set-Up, Parameter Data Set, Parameter Data Check, Drive Information, Data Readouts, Logs & I/O Option Status, and Advanced Parameter Data Set.

All parameters can be changed in the Main Menu. The configuration of the unit (*H-40 Configuration Mode*) will determine other parameters available for programming. For example, selecting Closed Loop enables additional parameters related to closed loop operation. Option cards added to the unit enable additional parameters associated with the option device.

6.1.5 Parameter Selection

Main Menu Item	Parameter Groups:
Keypad Set-Up	K-##
Parameter Data Set	F-##, E-##, C-##, P-##, H-##, AN-##, SP-##, O-##, AO-##, DN-##, PB-##, LN-##, BN-##
Drive Information	ID-##
Data Readouts	DR-##
Logs & I/O Option Status	LG-##
Advanced Parameter Data Set	AP-##, FB-##, T-##, CL-##, XC-##, PC-##, LC-##, B-##

Table 6.3 Parameter Groups in Main Menu Items

Group no.	Parameter group:
K-##	Keypad Set-Up
F-##	Fundamental Parameters
E-##	Digital In/Out
C-##	Frequency Control Functions
P-##	Motor Data
H-##	High Perf Parameters
AN-##	Analog In/Out
SP-##	Special Functions
O-##	Options / Comms
AO-##	Analog I/O Option
DN-##	DeviceNet
PB-##	Profibus
LN-##	LonWorks
BN-##	BACnet
ID-##	Drive Information
DR-##	Data Readouts
LG-##	Logs & I/O Opt. Status
AP-##	HVAC Appl. Param.
FB-##	Fire/Bypass Operation
EN-##	EtherNet
T-##	Timed Functions
CL-##	PID Closed Loop
XC-##	Ext. PID Closed Loop
PC-##	Pump Controller
LC-##	Logic Controller
B-##	Braking Functions

Table 6.4 Parameter groups.

Choose a parameter group from the Main Menu and Press [OK]. Then further select the parameter sub-groups by using the up and down arrows and then Press [OK]. The middle section of the keypad display shows the parameters. Press [OK] to select parameters and now the display shows that selected parameter's value.

6.1.6 Changing Data

1. Press [Quick Menu] or [Main Menu] key.
2. Use [▲] and [▼] keys keys to find parameter group to edit.
3. Press [OK] key.
4. Use [▲] and [▼] keys to find parameter to edit.
5. Press [OK] key.
6. Use [▲] and [▼] keys to select correct parameter setting. Or, to move to digits within a number, use left or right arrow keys. Cursor indicates digit selected to change. [▲] key increases the value, [▼] key decreases the value.
7. Press [Cancel] key to disregard change, or press [OK] key to accept change and enter new setting.



6.1.7 Changing a Text Value

If the selected parameter is a text value, change the text value by means of the up/down navigation keys. The up key increases the value, and the down key decreases the value. Place the cursor on the value to be saved and press [OK].

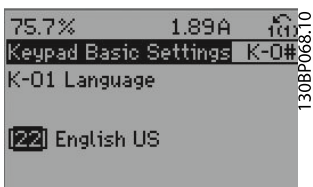

Illustration 6.9 Display example.

Choose a parameter group from the Main Menu and Press [OK]. Then further select the parameter sub-groups by using the up and down arrows and then Press [OK]. The middle section of the keypad display shows the parameters. Press [OK] to select parameters and now the display shows that selected parameter's value.

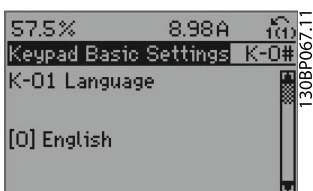

Illustration 6.10 Display example.

6.1.8 Changing a Group of Numeric Data Values

If the chosen parameter represents a numeric data value, change the chosen data value by means of the [◀] and [▶] navigation keys as well as the up/down [▲] [▼] navigation keys. Use the [◀] and [▶] navigation keys to move the cursor horizontally.

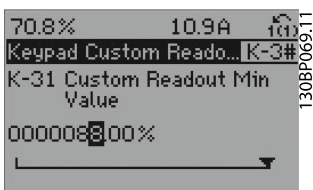

Illustration 6.11 Display example.

Use the up/down navigation keys to change the data value. The up key enlarges the data value, and the down key reduces the data value. Place the cursor on the value to be saved and press [OK].



Illustration 6.12 Display example.

6.1.9 Changing of Data Value, Step-by-Step

Certain parameters can be changed step by step or infinitely variably. This applies to *P-07 Motor Power [kW]*, *F-05 Motor Rated Voltage* and *F-04 Base Frequency*. The parameters are changed both as a group of numeric data values and as numeric data values infinitely variably.

6.1.10 Read-out and Programming of Indexed Parameters

Parameters are indexed when placed in a rolling stack. *ID-30 Alarm Log: Error Code* to *ID-32 Alarm Log: Time* contain a fault log which can be read out. Choose a parameter, press [OK], and use the up/down navigation keys to scroll through the value log.

Use *C-05 Multi-step Frequency 1 - 8* as another example: Choose the parameter, press [OK], and use the up/down navigation keys to scroll through the indexed values. To change the parameter value, select the indexed value and press [OK]. Change the value by using the up/down keys. Press [OK] to accept the new setting. Press [Cancel] to abort. Press [Back] to leave the parameter.



6.2 Parameter Lists

6.2.1 Main Menu Structure

Parameters for the frequency converter are grouped into various parameter groups for easy selection of the correct parameters for optimized operation of the frequency converter.

The vast majority of AF-600 FP applications can be programmed using the Quick Menu button and selecting the parameters under Quick Setup.

Descriptions and default settings of parameters may be found under the section Parameter Lists at the back of this manual.

K-## Keypad Set-up
F-## Fundamental Parameters
E-## Digital In/Outs
C-## Frequency Control Functions
P-## Motor Data
H-## High Perf Parameters
AN-## Analog In/Out
SP-## Special Functions
O-## Options/Comms
AO-## Analog I/O Options
DN-## DeviceNet
EN-## Ethernet
PB-## Profibus
LN-## LonWorks
BN-## BACnet
ID-## Drive Information
DR-## Data Readouts
LG-## Logs & I/O Opt. Status
AP-## HVAC Appl. Param.
FB-## Fire/Bypass Operation
T-## Timed Functions
CL-## PID Closed Loop
XC-## Ext. PID Closed Loop
PC-## Pump Controller
LC-## Logic Controller
B-## Braking Functions



6.2.2 K-## Keypad Set-up

6

Par. No. #	Parameter description	Default value	4-set-up	Change during operation	Conversion index	Type
K-0#						
K-01	Language	[0] English	1 set-up	TRUE	-	UInt8
K-02	Motor Speed Unit	[1] Hz	2 set-ups	FALSE	-	UInt8
K-03	Regional Settings	[1] North America	2 set-ups	FALSE	-	UInt8
K-04	Operating State at Power-up	[0] Resume	All set-ups	TRUE	-	UInt8
K-05	Local Mode Unit	[0] As Motor Speed Unit	2 set-ups	FALSE	-	UInt8
K-1#						
K-10	Active Set-up	[1] Set-up 1	1 set-up	TRUE	-	UInt8
K-11	Edit Set-up	[9] Active Set-up	All set-ups	TRUE	-	UInt8
K-12	This Set-up Linked to	[0] Not linked	All set-ups	FALSE	-	UInt8
K-13	Readout: Linked Set-ups	0 N/A	All set-ups	FALSE	0	UInt16
K-14	Readout: Edit Set-ups / Channel	0 N/A	All set-ups	TRUE	0	Int32
K-2#						
K-20	Display Line 1.1 Small	ExpressionLimit	All set-ups	TRUE	-	UInt16
K-21	Display Line 1.2 Small	ExpressionLimit	All set-ups	TRUE	-	UInt16
K-22	Display Line 1.3 Small	ExpressionLimit	All set-ups	TRUE	-	UInt16
K-23	Display Line 2 Large	ExpressionLimit	All set-ups	TRUE	-	UInt16
K-24	Display Line 3 Large	ExpressionLimit	All set-ups	TRUE	-	UInt16
K-25	Quick Start	ExpressionLimit	1 set-up	TRUE	0	UInt16
K-3#						
K-30	Unit for Custom Readout	[1] %	All set-ups	TRUE	-	UInt8
K-31	Min Value of Custom Readout	ExpressionLimit	All set-ups	TRUE	-2	Int32
K-32	Max Value of Custom Readout	100.00 CustomReadoutUnit	All set-ups	TRUE	-2	Int32
K-37	Display Text 1	0 N/A	1 set-up	TRUE	0	VisStr[25]
K-38	Display Text 2	0 N/A	1 set-up	TRUE	0	VisStr[25]
K-39	Display Text 3	0 N/A	1 set-up	TRUE	0	VisStr[25]
K-4#						
K-40	[Hand] Button on Keypad	[1] Enabled	All set-ups	TRUE	-	UInt8
K-41	[Off] Button on Keypad	[1] Enabled	All set-ups	TRUE	-	UInt8
K-42	[Auto] Button on Keypad	[1] Enabled	All set-ups	TRUE	-	UInt8
K-43	[Reset] Button on Keypad	[1] Enabled	All set-ups	TRUE	-	UInt8
K-5#						
K-50	Keypad Copy	[0] No copy	All set-ups	FALSE	-	UInt8
K-51	Set-up Copy	[0] No copy	All set-ups	FALSE	-	UInt8
K-6#						
K-60	Main Menu Password	100 N/A	1 set-up	TRUE	0	Int16
K-61	Access to Main Menu w/o Password	[0] Full access	1 set-up	TRUE	-	UInt8
K-65	Quick Menu Password	200 N/A	1 set-up	TRUE	0	Int16
K-66	Access to Quick Menu w/o Password	[0] Full access	1 set-up	TRUE	-	UInt8



How to Program

AF-600 FP High Power Operating Instructions

Par. No. #	Parameter description	Default value	4-set-up	Change during operation	Conversion index	Type
K-7#						
K-70	Date and Time	ExpressionLimit	All set-ups	TRUE	0	TimeOfDay
K-71	Date Format	null	1 set-up	TRUE	-	UInt8
K-72	Time Format	null	1 set-up	TRUE	-	UInt8
K-74	DST/Summertime	[0] Off	1 set-up	TRUE	-	UInt8
K-76	DST/Summertime Start	ExpressionLimit	1 set-up	TRUE	0	TimeOfDay
K-77	DST/Summertime End	ExpressionLimit	1 set-up	TRUE	0	TimeOfDay
K-79	Clock Fault	null	1 set-up	TRUE	-	UInt8
K-8#						
K-81	Working Days	null	1 set-up	TRUE	-	UInt8
K-82	Additional Working Days	ExpressionLimit	1 set-up	TRUE	0	TimeOfDay
K-83	Additional Non-Working Days	ExpressionLimit	1 set-up	TRUE	0	TimeOfDay
K-89	Date and Time Readout	0 N/A	All set-ups	TRUE	0	VisStr[25]

6



6.2.3 F-## Fundamental Parameters

6

Par. No. #	Parameter description	Default value	4-set-up	Change during operation	Conversion index	Type
F-0#						
F-01	Frequency Setting 1	[1] Analog input 53	All set-ups	TRUE	-	Uint8
F-02	Operation Method	[0] Linked to Hand / Auto	All set-ups	TRUE	-	Uint8
F-03	Max Output Frequency 1	ExpressionLimit	All set-ups	FALSE	-1	Uint16
F-04	Base Frequency	ExpressionLimit	All set-ups	FALSE	0	Uint16
F-05	Motor Rated Voltage	ExpressionLimit	All set-ups	FALSE	0	Uint16
F-07	Accel Time 1	ExpressionLimit	All set-ups	TRUE	-2	Uint32
F-08	Decel Time 1	ExpressionLimit	All set-ups	TRUE	-2	Uint32
F-1#						
F-10	Electronic Overload	[4] Elec. OL Trip 1	All set-ups	TRUE	-	Uint8
F-11	Motor External Fan	[0] No	All set-ups	TRUE	-	Uint16
F-12	Motor Thermistor Input	[0] None	All set-ups	TRUE	-	Uint8
F-15	Motor Speed High Limit [Hz]	ExpressionLimit	All set-ups	TRUE	-1	Uint16
F-16	Motor Speed Low Limit [Hz]	ExpressionLimit	All set-ups	TRUE	-1	Uint16
F-17	Motor Speed High Limit [RPM]	ExpressionLimit	All set-ups	TRUE	67	Uint16
F-18	Motor Speed Low Limit [RPM]	ExpressionLimit	All set-ups	TRUE	67	Uint16
F-2#						
F-24	Holding Time	0.0 s	All set-ups	TRUE	-1	Uint16
F-26	Motor Noise (Carrier Freq)	null	All set-ups	TRUE	-	Uint8
F-27	Motor Tone Random	[0] Off	All set-ups	TRUE	-	Uint8
F-3#						
F-37	Adv. Switching Pattern	null	All set-ups	TRUE	-	Uint8
F-38	Overmodulation	[1] On	All set-ups	FALSE	-	Uint8
F-4#						
F-40	Torque Limiter (Driving)	ExpressionLimit	All set-ups	TRUE	-1	Uint16
F-41	Torque Limiter (Braking)	100.0 %	All set-ups	TRUE	-1	Uint16
F-43	Current Limit	ExpressionLimit	All set-ups	TRUE	-1	Uint32
F-5#						
F-52	Minimum Reference	ExpressionLimit	All set-ups	TRUE	-3	Int32
F-53	Maximum Reference	ExpressionLimit	All set-ups	TRUE	-3	Int32
F-54	Reference Function	null	All set-ups	TRUE	-	Uint8
F-6#						
F-64	Preset Relative Reference	0.00 %	All set-ups	TRUE	-2	Int32
F-9#						
F-90	Step Size	0.10 %	All set-ups	TRUE	-2	Uint16
F-91	Accel/Decel Time	1.00 s	All set-ups	TRUE	-2	Uint32
F-92	Power Restore	[0] Off	All set-ups	TRUE	-	Uint8
F-93	Maximum Limit	100 %	All set-ups	TRUE	0	Int16
F-94	Minimum Limit	0 %	All set-ups	TRUE	0	Int16
F-95	Accel/Decel Ramp Delay	ExpressionLimit	All set-ups	TRUE	-3	TimD



6.2.4 E-## Digital In/Outs

Par. No. #	Parameter description	Default value	4-set-up	Change during operation	Conversion index	Type
E-0#						
E-00	Digital I/O Mode	[0] PNP - Active at 24V	All set-ups	FALSE	-	Uint8
E-01	Terminal 18 Digital Input	[8] Start	All set-ups	TRUE	-	Uint8
E-02	Terminal 19 Digital Input	[0] No operation	All set-ups	TRUE	-	Uint8
E-03	Terminal 27 Digital Input	[0] No operation	All set-ups	TRUE	-	Uint8
E-04	Terminal 29 Digital Input	[14] Jog	All set-ups	TRUE	-	Uint8
E-05	Terminal 32 Digital Input	[0] No operation	All set-ups	TRUE	-	Uint8
E-06	Terminal 33 Digital Input	[0] No operation	All set-ups	TRUE	-	Uint8
E-1#						
E-10	Accel Time 2	ExpressionLimit	All set-ups	TRUE	-2	Uint32
E-11	Decel Time 2	ExpressionLimit	All set-ups	TRUE	-2	Uint32
E-2#						
E-20	Terminal 27 Digital Output	[0] No operation	All set-ups	TRUE	-	Uint8
E-21	Terminal 29 Digital Output	[0] No operation	All set-ups	TRUE	-	Uint8
E-24	Function Relay	null	All set-ups	TRUE	-	Uint8
E-26	On Delay, Relay	0.01 s	All set-ups	TRUE	-2	Uint16
E-27	Off Delay, Relay	0.01 s	All set-ups	TRUE	-2	Uint16
E-5#						
E-51	Terminal 27 Mode	[0] Input	All set-ups	TRUE	-	Uint8
E-52	Terminal 29 Mode	[0] Input	All set-ups	TRUE	-	Uint8
E-53	Terminal X30/2 Digital Input	[0] No operation	All set-ups	TRUE	-	Uint8
E-54	Terminal X30/3 Digital Input	[0] No operation	All set-ups	TRUE	-	Uint8
E-55	Terminal X30/4 Digital Input	[0] No operation	All set-ups	TRUE	-	Uint8
E-56	Term X30/6 Digi Out (OPCGPIO)	[0] No operation	All set-ups	TRUE	-	Uint8
E-57	Term X30/7 Digi Out (OPCGPIO)	[0] No operation	All set-ups	TRUE	-	Uint8
E-6#						
E-60	Term. 29 Low Frequency	100 Hz	All set-ups	TRUE	0	Uint32
E-61	Term. 29 High Frequency	100 Hz	All set-ups	TRUE	0	Uint32
E-62	Term. 29 Low Ref./Feedb. Value	0.000 N/A	All set-ups	TRUE	-3	Int32
E-63	Term. 29 High Ref./Feedb. Value	100.000 N/A	All set-ups	TRUE	-3	Int32
E-64	Pulse Filter Time Constant #29	100 ms	All set-ups	FALSE	-3	Uint16
E-65	Term. 33 Low Frequency	100 Hz	All set-ups	TRUE	0	Uint32
E-66	Term. 33 High Frequency	100 Hz	All set-ups	TRUE	0	Uint32
E-67	Term. 33 Low Ref./Feedb. Value	0.000 N/A	All set-ups	TRUE	-3	Int32
E-68	Term. 33 High Ref./Feedb. Value	100.000 N/A	All set-ups	TRUE	-3	Int32
E-69	Pulse Filter Time Constant #33	100 ms	All set-ups	FALSE	-3	Uint16



How to Program

AF-600 FP High Power Operating Instructions

Par. No. #	Parameter description	Default value	4-set-up	Change during operation	Conversion index	Type
E-7#						
E-70	Terminal 27 Pulse Output Variable	[0] No operation	All set-ups	TRUE	-	Uint8
E-71	Pulse Output Max Freq #27	5000 Hz	All set-ups	TRUE	0	Uint32
E-72	Terminal 29 Pulse Output Variable	[0] No operation	All set-ups	TRUE	-	Uint8
E-74	Pulse Output Max Freq #29	5000 Hz	All set-ups	TRUE	0	Uint32
E-75	Terminal X30/6 Pulse Output Variable	[0] No operation	All set-ups	TRUE	-	Uint8
E-76	Pulse Output Max Freq #X30/6	5000 Hz	All set-ups	TRUE	0	Uint32
E-9#						
E-90	Digital & Relay Bus Control	0 N/A	All set-ups	TRUE	0	Uint32
E-93	Pulse Out #27 Bus Control	0.00 %	All set-ups	TRUE	-2	N2
E-94	Pulse Out #27 Timeout Preset	0.00 %	1 set-up	TRUE	-2	Uint16
E-95	Pulse Out #29 Bus Control	0.00 %	All set-ups	TRUE	-2	N2
E-96	Pulse Out #29 Timeout Preset	0.00 %	1 set-up	TRUE	-2	Uint16
E-97	Pulse Out #X30/6 Bus Control	0.00 %	All set-ups	TRUE	-2	N2
E-98	Pulse Out #X30/6 Timeout Preset	0.00 %	1 set-up	TRUE	-2	Uint16

6



6.2.5 C-## Frequency Control Functions

Par. No. #	Parameter description	Default value	4-set-up	Change during operation	Conversion index	Type
C-0#						
C-01	Jump Frequency From [Hz]	ExpressionLimit	All set-ups	TRUE	-1	Uint16
C-02	Jump Speed From [RPM]	ExpressionLimit	All set-ups	TRUE	67	Uint16
C-03	Jump Speed To [RPM]	ExpressionLimit	All set-ups	TRUE	67	Uint16
C-04	Jump Frequency To [Hz]	ExpressionLimit	All set-ups	TRUE	-1	Uint16
C-05	Multi-step Frequency 1 - 8	0.00 %	All set-ups	TRUE	-2	Int16
C-2#						
C-20	Jog Speed [Hz]	ExpressionLimit	All set-ups	TRUE	-1	Uint16
C-21	Jog Speed [RPM]	ExpressionLimit	All set-ups	TRUE	67	Uint16
C-22	Jog Accel/Decel Time	ExpressionLimit	All set-ups	TRUE	-2	Uint32
C-23	Quick Stop Decel Time	ExpressionLimit	2 set-ups	TRUE	-2	Uint32
C-3#						
C-30	Frequency Command 2	[20] Digital Potentiometer	All set-ups	TRUE	-	Uint8
C-34	Frequency Command 3	[0] No function	All set-ups	TRUE	-	Uint8
C-4#						
C-40	Semi-Auto Jump Freq Set-up	[0] Off	All set-ups	FALSE	-	Uint8

6.2.6 P-## Motor Data

Par. No. #	Parameter description	Default value	4-set-up	Change during operation	Conversion index	Type
P-0#						
P-02	Motor Power [HP]	ExpressionLimit	All set-ups	FALSE	-2	Uint32
P-03	Motor Current	ExpressionLimit	All set-ups	FALSE	-2	Uint32
P-04	Auto Tune	[0] Off	All set-ups	FALSE	-	Uint8
P-06	Base Speed	ExpressionLimit	All set-ups	FALSE	67	Uint16
P-07	Motor Power [kW]	ExpressionLimit	All set-ups	FALSE	1	Uint32
P-08	Motor Rotation Check	[0] Off	All set-ups	FALSE	-	Uint8
P-09	Slip Compensation	0 %	All set-ups	TRUE	0	Int16
P-1#						
P-10	Slip Compensation Time Constant	ExpressionLimit	All set-ups	TRUE	-2	Uint16
P-3#						
P-30	Stator Resistance (Rs)	ExpressionLimit	All set-ups	FALSE	-4	Uint32
P-31	Rotor Resistance (Rr)	ExpressionLimit	All set-ups	FALSE	-4	Uint32
P-35	Main Reactance (Xh)	ExpressionLimit	All set-ups	FALSE	-4	Uint32
P-36	Iron Loss Resistance (Rfe)	ExpressionLimit	All set-ups	FALSE	-3	Uint32



6.2.7 H-## High Perf Parameters

6

Par. No. #	Parameter description	Default value	4-set-up	Change during operation	Conversion index	Type
H-0#						
H-03	Restore Factory Settings	[0] Normal operation	All set-ups	TRUE	-	Uint8
H-04	Auto-Reset (Times)	null	All set-ups	TRUE	-	Uint8
H-05	Auto-Reset (Reset Interval)	10 s	All set-ups	TRUE	0	Uint16
H-06	Fan Operation	[0] Auto	All set-ups	TRUE	-	Uint8
H-08	Reverse Lock	[2] Both directions	All set-ups	FALSE	-	Uint8
H-09	Start Mode	[0] Disabled	All set-ups	TRUE	-	Uint8
H-3#						
H-36	Trip Speed Low [RPM]	ExpressionLimit	All set-ups	TRUE	67	Uint16
H-37	Trip Speed Low [Hz]	ExpressionLimit	All set-ups	TRUE	-1	Uint16
H-4#						
H-40	Configuration Mode	null	All set-ups	TRUE	-	Uint8
H-43	Torque Characteristics	[3] Auto Energy Optim. VT	All set-ups	TRUE	-	Uint8
H-48	Clockwise Direction	[0] Normal	All set-ups	FALSE	-	Uint8
H-5#						
H-58	Flystart Test Pulses Current	30 %	All set-ups	FALSE	0	Uint16
H-59	Flystart Test Pulses Frequency	200 %	All set-ups	FALSE	0	Uint16
H-6#						
H-64	Resonance Dampening	100 %	All set-ups	TRUE	0	Uint16
H-65	Resonance Dampening Time Constant	5 ms	All set-ups	TRUE	-3	Uint8
H-7#						
H-70	Warning Current Low	0.00 A	All set-ups	TRUE	-2	Uint32
H-71	Warning Current High	ExpressionLimit	All set-ups	TRUE	-2	Uint32
H-72	Warning Speed Low	0 RPM	All set-ups	TRUE	67	Uint16
H-73	Warning Speed High	ExpressionLimit	All set-ups	TRUE	67	Uint16
H-74	Warning Reference Low	-999999.999 N/A	All set-ups	TRUE	-3	Int32
H-75	Warning Reference High	999999.999 N/A	All set-ups	TRUE	-3	Int32
H-76	Warning Feedback Low	-999999.999 ProcessCtrlUnit	All set-ups	TRUE	-3	Int32
H-77	Warning Feedback High	999999.999 ProcessCtrlUnit	All set-ups	TRUE	-3	Int32
H-78	Missing Motor Phase Function	[2] Trip 1000 ms	All set-ups	TRUE	-	Uint8
H-8#						
H-80	Function at Stop	[0] Coast	All set-ups	TRUE	-	Uint8
H-81	Min Speed for Function at Stop [RPM]	ExpressionLimit	All set-ups	TRUE	67	Uint16
H-82	Min Speed for Function at Stop [Hz]	ExpressionLimit	All set-ups	TRUE	-1	Uint16



6.2.8 AN-## Analog In / Out

Par. No. #	Parameter description	Default value	4-set-up	Change during operation	Conversion index	Type
AN-0#						
AN-00	Live Zero Timeout Time	10 s	All set-ups	TRUE	0	Uint8
AN-01	Live Zero Timeout Function	[0] Off	All set-ups	TRUE	-	Uint8
AN-02	Fire Mode Live Zero Timeout Function	[0] Off	All set-ups	TRUE	-	Uint8
AN-1#						
AN-10	Terminal 53 Low Voltage	0.07 V	All set-ups	TRUE	-2	Int16
AN-11	Terminal 53 High Voltage	10.00 V	All set-ups	TRUE	-2	Int16
AN-12	Terminal 53 Low Current	4.00 mA	All set-ups	TRUE	-5	Int16
AN-13	Terminal 53 High Current	20.00 mA	All set-ups	TRUE	-5	Int16
AN-14	Terminal 53 Low Ref./Feedb. Value	0.000 N/A	All set-ups	TRUE	-3	Int32
AN-15	Terminal 53 High Ref./Feedb. Value	ExpressionLimit	All set-ups	TRUE	-3	Int32
AN-16	Terminal 53 Filter Time Constant	0.001 s	All set-ups	TRUE	-3	Uint16
AN-17	Terminal 53 Live Zero	[1] Enabled	All set-ups	TRUE	-	Uint8
AN-2#						
AN-20	Terminal 54 Low Voltage	0.07 V	All set-ups	TRUE	-2	Int16
AN-21	Terminal 54 High Voltage	10.00 V	All set-ups	TRUE	-2	Int16
AN-22	Terminal 54 Low Current	4.00 mA	All set-ups	TRUE	-5	Int16
AN-23	Terminal 54 High Current	20.00 mA	All set-ups	TRUE	-5	Int16
AN-24	Terminal 54 Low Ref./Feedb. Value	0.000 N/A	All set-ups	TRUE	-3	Int32
AN-25	Terminal 54 High Ref./Feedb. Value	100.000 N/A	All set-ups	TRUE	-3	Int32
AN-26	Terminal 54 Filter Time Constant	0.001 s	All set-ups	TRUE	-3	Uint16
AN-27	Terminal 54 Live Zero	[1] Enabled	All set-ups	TRUE	-	Uint8
AN-3#						
AN-30	Terminal X30/11 Low Voltage	0.07 V	All set-ups	TRUE	-2	Int16
AN-31	Terminal X30/11 High Voltage	10.00 V	All set-ups	TRUE	-2	Int16
AN-34	Term. X30/11 Low Ref./Feedb. Value	0.000 N/A	All set-ups	TRUE	-3	Int32
AN-35	Term. X30/11 High Ref./Feedb. Value	100.000 N/A	All set-ups	TRUE	-3	Int32
AN-36	Term. X30/11 Filter Time Constant	0.001 s	All set-ups	TRUE	-3	Uint16
AN-37	Term. X30/11 Live Zero	[1] Enabled	All set-ups	TRUE	-	Uint8
AN-4#						
AN-40	Terminal X30/12 Low Voltage	0.07 V	All set-ups	TRUE	-2	Int16
AN-41	Terminal X30/12 High Voltage	10.00 V	All set-ups	TRUE	-2	Int16
AN-44	Term. X30/12 Low Ref./Feedb. Value	0.000 N/A	All set-ups	TRUE	-3	Int32
AN-45	Term. X30/12 High Ref./Feedb. Value	100.000 N/A	All set-ups	TRUE	-3	Int32
AN-46	Term. X30/12 Filter Time Constant	0.001 s	All set-ups	TRUE	-3	Uint16
AN-47	Term. X30/12 Live Zero	[1] Enabled	All set-ups	TRUE	-	Uint8
AN-5#						
AN-50	Terminal 42 Output	null	All set-ups	TRUE	-	Uint8
AN-51	Terminal 42 Output Min Scale	0.00 %	All set-ups	TRUE	-2	Int16
AN-52	Terminal 42 Output Max Scale	100.00 %	All set-ups	TRUE	-2	Int16
AN-53	Terminal 42 Output Bus Control	0.00 %	All set-ups	TRUE	-2	N2
AN-54	Terminal 42 Output Timeout Preset	0.00 %	1 set-up	TRUE	-2	Uint16
AN-6#						
AN-60	Terminal X30/8 Output	[0] No operation	All set-ups	TRUE	-	Uint8
AN-61	Terminal X30/8 Min. Scale	0.00 %	All set-ups	TRUE	-2	Int16
AN-62	Terminal X30/8 Max. Scale	100.00 %	All set-ups	TRUE	-2	Int16
AN-63	Terminal X30/8 Output Bus Control	0.00 %	All set-ups	TRUE	-2	N2
AN-64	Terminal X30/8 Output Timeout Preset	0.00 %	1 set-up	TRUE	-2	Uint16



6.2.9 SP-## Special Functions

6

Par. No. #	Parameter description	Default value	4-set-up	Change during operation	Conversion index	Type
SP-1#						
SP-10	Line failure	[0] No function	All set-ups	FALSE	-	Uint8
SP-11	Line Voltage at Input Fault	ExpressionLimit	All set-ups	TRUE	0	Uint16
SP-12	Function at Line Imbalance	[0] Trip	All set-ups	TRUE	-	Uint8
SP-2#						
SP-23	Typecode Setting	null	2 set-ups	FALSE	-	Uint8
SP-25	Trip Delay at Torque Limit	60 s	All set-ups	TRUE	0	Uint8
SP-26	Trip Delay at Drive Fault	ExpressionLimit	All set-ups	TRUE	0	Uint8
SP-28	Production Settings	[0] No action	All set-ups	TRUE	-	Uint8
SP-29	Service Code	0 N/A	All set-ups	TRUE	0	Int32
SP-3#						
SP-30	Current Lim Ctrl, Proportional Gain	100 %	All set-ups	FALSE	0	Uint16
SP-31	Current Lim Ctrl, Integration Time	0.020 s	All set-ups	FALSE	-3	Uint16
SP-32	Current Lim Ctrl, Filter Time	26.0 ms	All set-ups	TRUE	-4	Uint16
SP-4#						
SP-40	VT Level	66 %	All set-ups	FALSE	0	Uint8
SP-41	Energy Savings Min. Magnetization	ExpressionLimit	All set-ups	TRUE	0	Uint8
SP-42	Energy Savings Min. Frequency	10 Hz	All set-ups	TRUE	0	Uint8
SP-43	Motor Cosphi	ExpressionLimit	All set-ups	TRUE	-2	Uint16
SP-5#						
SP-50	RFI Filter	[1] On	1 set-up	FALSE	-	Uint8
SP-51	DC Link Compensation	[1] On	1 set-up	TRUE	-	Uint8
SP-53	Fan Monitor	[1] Warning	All set-ups	TRUE	-	Uint8
SP-55	Output Filter	[0] No Filter	1 set-up	FALSE	-	Uint8
SP-59	Actual Number of Inverter Units	ExpressionLimit	1 set-up	FALSE	0	Uint8
SP-6#						
SP-60	Function at Over Temperature	[0] Trip	All set-ups	TRUE	-	Uint8
SP-61	Function at Drive Overload	[0] Trip	All set-ups	TRUE	-	Uint8
SP-62	Drive Overload Derate Current	95 %	All set-ups	TRUE	0	Uint16



6.2.10 O-## Options/Comms

Par. No. #	Parameter description	Default value	4-set-up	Change during operation	Conversion index	Type
O-0#						
O-01	Control Site	null	All set-ups	TRUE	-	Uint8
O-02	Control Word Source	null	All set-ups	TRUE	-	Uint8
O-03	Control Word Timeout Time	ExpressionLimit	1 set-up	TRUE	-1	Uint32
O-04	Control Word Timeout Function	[0] Off	1 set-up	TRUE	-	Uint8
O-05	End-of-Timeout Function	[1] Resume set-up	1 set-up	TRUE	-	Uint8
O-06	Reset Control Word Timeout	[0] Do not reset	All set-ups	TRUE	-	Uint8
O-07	Diagnosis Trigger	[0] Disable	2 set-ups	TRUE	-	Uint8
O-1#						
O-10	Control Word Profile	[0] Drive Profile	All set-ups	TRUE	-	Uint8
O-13	Configurable Status Word STW	[1] Profile Default	All set-ups	TRUE	-	Uint8
O-3#						
O-30	Protocol	null	1 set-up	TRUE	-	Uint8
O-31	Address	ExpressionLimit	1 set-up	TRUE	0	Uint8
O-32	Drive Port Baud Rate	null	1 set-up	TRUE	-	Uint8
O-33	Drive Port Parity	null	1 set-up	TRUE	-	Uint8
O-34	Estimated cycle time	0 ms	2 set-ups	TRUE	-3	Uint32
O-35	Minimum Response Delay	ExpressionLimit	1 set-up	TRUE	-3	Uint16
O-36	Maximum Response Delay	ExpressionLimit	1 set-up	TRUE	-3	Uint16
O-37	Maximum Inter-Char Delay	ExpressionLimit	1 set-up	TRUE	-5	Uint16
O-4#						
O-40	Telegram Selection	[1] Standard telegram 1	2 set-ups	TRUE	-	Uint8
O-42	PCD write configuration	ExpressionLimit	All set-ups	TRUE	-	Uint16
O-43	PCD read configuration	ExpressionLimit	All set-ups	TRUE	-	Uint16
O-5#						
O-50	Coasting Select	[3] Logic OR	All set-ups	TRUE	-	Uint8
O-52	DC Brake Select	[3] Logic OR	All set-ups	TRUE	-	Uint8
O-53	Start Select	[3] Logic OR	All set-ups	TRUE	-	Uint8
O-54	Reversing Select	null	All set-ups	TRUE	-	Uint8
O-55	Set-up Select	[3] Logic OR	All set-ups	TRUE	-	Uint8
O-56	Preset Reference Select	[3] Logic OR	All set-ups	TRUE	-	Uint8
O-8#						
O-80	Bus Message Count	0 N/A	All set-ups	TRUE	0	Uint32
O-81	Bus Error Count	0 N/A	All set-ups	TRUE	0	Uint32
O-82	Slave Messages Rcvd	0 N/A	All set-ups	TRUE	0	Uint32
O-83	Slave Error Count	0 N/A	All set-ups	TRUE	0	Uint32
O-89	Diagnostics Count	0 N/A	1 set-up	TRUE	0	Int32
O-9#						
O-90	Bus Jog 1 Speed	100 RPM	All set-ups	TRUE	67	Uint16
O-91	Bus Jog 2 Speed	200 RPM	All set-ups	TRUE	67	Uint16
O-94	Bus Feedback 1	0 N/A	1 set-up	TRUE	0	N2
O-95	Bus Feedback 2	0 N/A	1 set-up	TRUE	0	N2
O-96	Bus Feedback 3	0 N/A	1 set-up	TRUE	0	N2



6.2.11 AO-## Analog I/O Option

6

Par. No. #	Parameter description	Default value	4-set-up	Change during operation	Conversion index	Type
AO-0#						
AO-00	Terminal X42/1 Mode	[1] Voltage	All set-ups	TRUE	-	Uint8
AO-01	Terminal X42/3 Mode	[1] Voltage	All set-ups	TRUE	-	Uint8
AO-02	Terminal X42/5 Mode	[1] Voltage	All set-ups	TRUE	-	Uint8
AO-1#						
AO-10	Terminal X42/1 Low Voltage	0.07 V	All set-ups	TRUE	-2	Int16
AO-11	Terminal X42/1 High Voltage	10.00 V	All set-ups	TRUE	-2	Int16
AO-14	Term. X42/1 Low Ref./Feedb. Value	0.000 N/A	All set-ups	TRUE	-3	Int32
AO-15	Term. X42/1 High Ref./Feedb. Value	100.000 N/A	All set-ups	TRUE	-3	Int32
AO-16	Term. X42/1 Filter Time Constant	0.001 s	All set-ups	TRUE	-3	Uint16
AO-17	Term. X42/1 Live Zero	[1] Enabled	All set-ups	TRUE	-	Uint8
AO-2#						
AO-20	Terminal X42/3 Low Voltage	0.07 V	All set-ups	TRUE	-2	Int16
AO-21	Terminal X42/3 High Voltage	10.00 V	All set-ups	TRUE	-2	Int16
AO-24	Term. X42/3 Low Ref./Feedb. Value	0.000 N/A	All set-ups	TRUE	-3	Int32
AO-25	Term. X42/3 High Ref./Feedb. Value	100.000 N/A	All set-ups	TRUE	-3	Int32
AO-26	Term. X42/3 Filter Time Constant	0.001 s	All set-ups	TRUE	-3	Uint16
AO-27	Term. X42/3 Live Zero	[1] Enabled	All set-ups	TRUE	-	Uint8
AO-3#						
AO-30	Terminal X42/5 Low Voltage	0.07 V	All set-ups	TRUE	-2	Int16
AO-31	Terminal X42/5 High Voltage	10.00 V	All set-ups	TRUE	-2	Int16
AO-34	Term. X42/5 Low Ref./Feedb. Value	0.000 N/A	All set-ups	TRUE	-3	Int32
AO-35	Term. X42/5 High Ref./Feedb. Value	100.000 N/A	All set-ups	TRUE	-3	Int32
AO-36	Term. X42/5 Filter Time Constant	0.001 s	All set-ups	TRUE	-3	Uint16
AO-37	Term. X42/5 Live Zero	[1] Enabled	All set-ups	TRUE	-	Uint8
AO-4#						
AO-40	Terminal X42/7 Output	[0] No operation	All set-ups	TRUE	-	Uint8
AO-41	Terminal X42/7 Min. Scale	0.00 %	All set-ups	TRUE	-2	Int16
AO-42	Terminal X42/7 Max. Scale	100.00 %	All set-ups	TRUE	-2	Int16
AO-43	Terminal X42/7 Bus Control	0.00 %	All set-ups	TRUE	-2	N2
AO-44	Terminal X42/7 Timeout Preset	0.00 %	1 set-up	TRUE	-2	Uint16
AO-5#						
AO-50	Terminal X42/9 Output	[0] No operation	All set-ups	TRUE	-	Uint8
AO-51	Terminal X42/9 Min. Scale	0.00 %	All set-ups	TRUE	-2	Int16
AO-52	Terminal X42/9 Max. Scale	100.00 %	All set-ups	TRUE	-2	Int16
AO-53	Terminal X42/9 Bus Control	0.00 %	All set-ups	TRUE	-2	N2
AO-54	Terminal X42/9 Timeout Preset	0.00 %	1 set-up	TRUE	-2	Uint16
AO-6#						
AO-60	Terminal X42/11 Output	[0] No operation	All set-ups	TRUE	-	Uint8
AO-61	Terminal X42/11 Min. Scale	0.00 %	All set-ups	TRUE	-2	Int16
AO-62	Terminal X42/11 Max. Scale	100.00 %	All set-ups	TRUE	-2	Int16
AO-63	Terminal X42/11 Bus Control	0.00 %	All set-ups	TRUE	-2	N2
AO-64	Terminal X42/11 Timeout Preset	0.00 %	1 set-up	TRUE	-2	Uint16



6.2.12 DN-## DevicNet

Par. No. #	Parameter description	Default value	4-set-up	Change during operation	Conversion index	Type
DN-0#						
DN-00	DeviceNet Protocol	null	2 set-ups	FALSE	-	Uint8
DN-01	Baud Rate Select	null	2 set-ups	TRUE	-	Uint8
DN-02	MAC ID	ExpressionLimit	2 set-ups	TRUE	0	Uint8
DN-05	Readout Transmit Error Counter	0 N/A	All set-ups	TRUE	0	Uint8
DN-06	Readout Receive Error Counter	0 N/A	All set-ups	TRUE	0	Uint8
DN-07	Readout Bus Off Counter	0 N/A	All set-ups	TRUE	0	Uint8
DN-1#						
DN-10	Process Data Type Selection	null	All set-ups	TRUE	-	Uint8
DN-11	Process Data Config Write	ExpressionLimit	2 set-ups	TRUE	-	Uint16
DN-12	Process Data Config Read	ExpressionLimit	2 set-ups	TRUE	-	Uint16
DN-13	Warning Parameter	0 N/A	All set-ups	TRUE	0	Uint16
DN-14	Net Reference	[0] Off	2 set-ups	TRUE	-	Uint8
DN-15	Net Control	[0] Off	2 set-ups	TRUE	-	Uint8
DN-2#						
DN-20	COS Filter 1	0 N/A	All set-ups	FALSE	0	Uint16
DN-21	COS Filter 2	0 N/A	All set-ups	FALSE	0	Uint16
DN-22	COS Filter 3	0 N/A	All set-ups	FALSE	0	Uint16
DN-23	COS Filter 4	0 N/A	All set-ups	FALSE	0	Uint16
DN-3#						
DN-30	Array Index	0 N/A	2 set-ups	TRUE	0	Uint8
DN-31	Store Data Values	[0] Off	All set-ups	TRUE	-	Uint8
DN-32	Devicenet Revision	0 N/A	All set-ups	TRUE	0	Uint16
DN-33	Store Always	[0] Off	1 set-up	TRUE	-	Uint8
DN-34	DeviceNet Product Code	210 N/A	1 set-up	TRUE	0	Uint16



6.2.13 PB-## Profibus

6

Par. No. #	Parameter description	Default value	4-set-up	Change during operation	Conversion index	Type
PB-1#						
PB-15	PCD Write Configuration	ExpressionLimit	2 set-ups	TRUE	-	Uint16
PB-16	PCD Read Configuration	ExpressionLimit	2 set-ups	TRUE	-	Uint16
PB-18	Node Address	126 N/A	1 set-up	TRUE	0	Uint8
PB-2#						
PB-22	Telegram Selection	[108] PPO 8	1 set-up	TRUE	-	Uint8
PB-23	Parameters for Signals	0	All set-ups	TRUE	-	Uint16
PB-27	Parameter Edit	[1] Enabled	2 set-ups	FALSE	-	Uint16
PB-28	Process Control	[1] Enable cyclic master	2 set-ups	FALSE	-	Uint8
PB-5#						
PB-53	Profibus Warning Word	0 N/A	All set-ups	TRUE	0	V2
PB-6#						
PB-63	Actual Baud Rate	[255] No baudrate found	All set-ups	TRUE	-	Uint8
PB-7#						
PB-71	Profibus Save Data Values	[0] Off	All set-ups	TRUE	-	Uint8
PB-72	ProfibusDriveReset	[0] No action	1 set-up	FALSE	-	Uint8
PB-8#						
PB-80	Defined Parameters (1)	0 N/A	All set-ups	FALSE	0	Uint16
PB-81	Defined Parameters (2)	0 N/A	All set-ups	FALSE	0	Uint16
PB-82	Defined Parameters (3)	0 N/A	All set-ups	FALSE	0	Uint16
PB-83	Defined Parameters (4)	0 N/A	All set-ups	FALSE	0	Uint16
PB-84	Defined Parameters (5)	0 N/A	All set-ups	FALSE	0	Uint16
PB-9#						
PB-90	Changed Parameters (1)	0 N/A	All set-ups	FALSE	0	Uint16
PB-91	Changed Parameters (2)	0 N/A	All set-ups	FALSE	0	Uint16
PB-92	Changed Parameters (3)	0 N/A	All set-ups	FALSE	0	Uint16
PB-93	Changed Parameters (4)	0 N/A	All set-ups	FALSE	0	Uint16
PB-94	Changed Parameters (5)	0 N/A	All set-ups	FALSE	0	Uint16



6.2.14 EN-## EtherNet

Par. No. #	Parameter description	Default value	4-set-up	Change during operation	Conversion index	Type
EN-0#						
EN-00	IP Address Assignment	null	2 set-ups	TRUE	-	UInt8
EN-01	IP Address	0 N/A	2 set-ups	TRUE	0	OctStr[4]
EN-02	Subnet Mask	0 N/A	2 set-ups	TRUE	0	OctStr[4]
EN-03	Default Gateway	0 N/A	2 set-ups	TRUE	0	OctStr[4]
EN-04	DHCP Server	0 N/A	2 set-ups	TRUE	0	OctStr[4]
EN-05	Lease Expires	ExpressionLimit	All set-ups	TRUE	0	TimD
EN-06	Name Servers	0 N/A	2 set-ups	TRUE	0	OctStr[4]
EN-07	Domain Name	0 N/A	2 set-ups	TRUE	0	VisStr[48]
EN-08	Host Name	0 N/A	2 set-ups	TRUE	0	VisStr[48]
EN-09	Physical Address	0 N/A	1 set-up	TRUE	0	VisStr[17]
EN-1#						
EN-10	Link Status	[0] No Link	All set-ups	TRUE	-	UInt8
EN-11	Link Duration	ExpressionLimit	All set-ups	TRUE	0	TimD
EN-12	Auto Negotiation	[1] On	2 set-ups	TRUE	-	UInt8
EN-13	Link Speed	[0] None	2 set-ups	TRUE	-	UInt8
EN-14	Link Duplex	[1] Full Duplex	2 set-ups	TRUE	-	UInt8
EN-2#						
EN-20	Control Instance	ExpressionLimit	1 set-up	TRUE	0	UInt8
EN-21	Process Data Config Write	ExpressionLimit	All set-ups	TRUE	-	UInt16
EN-22	Process Data Config Read	ExpressionLimit	All set-ups	TRUE	-	UInt16
EN-28	Store Data Values	[0] Off	All set-ups	TRUE	-	UInt8
EN-29	Store Always	[0] Off	1 set-up	TRUE	-	UInt8
EN-3#						
EN-30	Warning Parameter	0 N/A	All set-ups	TRUE	0	UInt16
EN-31	Net Reference	[0] Off	2 set-ups	TRUE	-	UInt8
EN-32	Net Control	[0] Off	2 set-ups	TRUE	-	UInt8
EN-33	CIP Revision	ExpressionLimit	All set-ups	TRUE	0	UInt16
EN-34	CIP Product Code	ExpressionLimit	1 set-up	TRUE	0	UInt16
EN-37	COS Inhibit Timer	0 N/A	All set-ups	TRUE	0	UInt16
EN-38	COS Filter	0 N/A	All set-ups	TRUE	0	UInt16
EN-4#						
EN-40	Status Parameter	0 N/A	All set-ups	TRUE	0	UInt16
EN-41	Slave Message Count	0 N/A	All set-ups	TRUE	0	UInt32
EN-42	Slave Exception Message Count	0 N/A	All set-ups	TRUE	0	UInt32
EN-8#						
EN-80	FTP Server	[0] Disabled	2 set-ups	TRUE	-	UInt8
EN-81	HTTP Server	[0] Disabled	2 set-ups	TRUE	-	UInt8
EN-82	SMTP Service	[0] Disabled	2 set-ups	TRUE	-	UInt8
EN-89	Transparent Socket Channel Port	4000 N/A	2 set-ups	TRUE	0	UInt16
EN-9#						
EN-90	Cable Diagnostic	[0] Disabled	2 set-ups	TRUE	-	UInt8
EN-91	MDI-X	[1] Enabled	2 set-ups	TRUE	-	UInt8
EN-92	IGMP Snooping	[1] Enabled	2 set-ups	TRUE	-	UInt8
EN-93	Cable Error Length	0 N/A	1 set-up	TRUE	0	UInt16
EN-94	Broadcast Storm Protection	-1 %	2 set-ups	TRUE	0	Int8
EN-95	Broadcast Storm Filter	[0] Broadcast only	2 set-ups	TRUE	-	UInt8
EN-98	Interface Counters	4000 N/A	All set-ups	TRUE	0	UInt32
EN-99	Media Counters	0 N/A	All set-ups	TRUE	0	UInt32



6.2.15 BN-## BACnet

Par. No. #	Parameter description	Default value	4-set-up	Change during operation	Conversion index	Type
BN-7#						
BN-70	BACnet Device Instance	1 N/A	1 set-up	TRUE	0	Uint32
BN-72	MS/TP Max Masters	127 N/A	1 set-up	TRUE	0	Uint8
BN-73	MS/TP Max Info Frames	1 N/A	1 set-up	TRUE	0	Uint16
BN-74	"I-Am" Service	[0] Send at power-up	1 set-up	TRUE	-	Uint8
BN-75	Initialization Password	ExpressionLimit	1 set-up	TRUE	0	VisStr[20]

6.2.16 LN-## LonWorks

Par. No. #	Parameter description	Default value	4-set-up	Change during operation	Conversion index	Type
LN-0#						
LN-00	Neuron ID	0 N/A	All set-ups	TRUE	0	OctStr[6]
LN-1#						
LN-10	Drive Profile	[0] VSD profile	All set-ups	TRUE	-	Uint8
LN-15	LON Warning Word	0 N/A	All set-ups	TRUE	0	Uint16
LN-17	XIF Revision	0 N/A	All set-ups	TRUE	0	VisStr[5]
LN-18	LonWorks Revision	0 N/A	All set-ups	TRUE	0	VisStr[5]
LN-2#						
LN-21	Store Data Values	[0] Off	All set-ups	TRUE	-	Uint8



6.2.17 ID-## Drive Information

Par. No. #	Parameter description	Default value	4-set-up	Change during operation	Conversion index	Type
ID-0#						
ID-00	Operating Hours	0 h	All set-ups	FALSE	74	Uint32
ID-01	Running Hours	0 h	All set-ups	FALSE	74	Uint32
ID-02	kWh Counter	0 kWh	All set-ups	FALSE	75	Uint32
ID-03	Power Up's	0 N/A	All set-ups	FALSE	0	Uint32
ID-04	Over Temp's	0 N/A	All set-ups	FALSE	0	Uint16
ID-05	Over Volt's	0 N/A	All set-ups	FALSE	0	Uint16
ID-06	Reset kWh Counter	[0] Do not reset	All set-ups	TRUE	-	Uint8
ID-07	Reset Running Hours Counter	[0] Do not reset	All set-ups	TRUE	-	Uint8
ID-08	Number of Starts	0 N/A	All set-ups	FALSE	0	Uint32
ID-1#						
ID-10	Trending Source	0	2 set-ups	TRUE	-	Uint16
ID-11	Trending Interval	ExpressionLimit	2 set-ups	TRUE	-3	TimD
ID-12	Trigger Event	[0] False	1 set-up	TRUE	-	Uint8
ID-13	Trending Mode	[0] Trend always	2 set-ups	TRUE	-	Uint8
ID-14	Samples Before Trigger	50 N/A	2 set-ups	TRUE	0	Uint8
ID-2#						
ID-20	Historic Log: Event	0 N/A	All set-ups	FALSE	0	Uint8
ID-21	Historic Log: Value	0 N/A	All set-ups	FALSE	0	Uint32
ID-22	Historic Log: Time	0 ms	All set-ups	FALSE	-3	Uint32
ID-23	Historic Log: Date and Time	ExpressionLimit	All set-ups	FALSE	0	TimeOfDay
ID-3#						
ID-30	Alarm Log: Error Code	0 N/A	All set-ups	FALSE	0	Uint8
ID-31	Alarm Log: Value	0 N/A	All set-ups	FALSE	0	Int16
ID-32	Alarm Log: Time	0 s	All set-ups	FALSE	0	Uint32
ID-33	Alarm Log: Date and Time	ExpressionLimit	All set-ups	FALSE	0	TimeOfDay
ID-4#						
ID-40	Drive Type	0 N/A	All set-ups	FALSE	0	VisStr[6]
ID-41	Power Section	0 N/A	All set-ups	FALSE	0	VisStr[20]
ID-42	Voltage	0 N/A	All set-ups	FALSE	0	VisStr[20]
ID-43	Software Version	0 N/A	All set-ups	FALSE	0	VisStr[5]
ID-44	GE Model Number	0 N/A	All set-ups	FALSE	0	VisStr[40]
ID-45	Actual Typecode String	0 N/A	All set-ups	FALSE	0	VisStr[40]
ID-46	GE Product No.	0 N/A	All set-ups	FALSE	0	VisStr[8]
ID-47	GE Power Card Model No	0 N/A	All set-ups	FALSE	0	VisStr[8]
ID-48	Keypad ID Number	0 N/A	All set-ups	FALSE	0	VisStr[20]
ID-49	SW ID Control Card	0 N/A	All set-ups	FALSE	0	VisStr[20]
ID-5#						
ID-50	SW ID Power Card	0 N/A	All set-ups	FALSE	0	VisStr[20]
ID-51	Drive Serial Number	0 N/A	All set-ups	FALSE	0	VisStr[10]
ID-53	Power Card Serial Number	0 N/A	All set-ups	FALSE	0	VisStr[19]
ID-6#						
ID-60	Option Mounted	0 N/A	All set-ups	FALSE	0	VisStr[30]
ID-61	Option SW Version	0 N/A	All set-ups	FALSE	0	VisStr[20]
ID-62	Option Ordering No	0 N/A	All set-ups	FALSE	0	VisStr[8]
ID-63	Option Serial No	0 N/A	All set-ups	FALSE	0	VisStr[18]
ID-9#						
ID-92	Defined Parameters	0 N/A	All set-ups	FALSE	0	Uint16
ID-93	Modified Parameters	0 N/A	All set-ups	FALSE	0	Uint16



6.2.18 DR-## Data Readouts

6

Par. No. #	Parameter description	Default value	4-set-up	Change during operation	Conversion index	Type
DR-0#						
DR-00	Control Word	0 N/A	All set-ups	FALSE	0	V2
DR-01	Reference [Unit]	0.000 ReferenceFeed-backUnit	All set-ups	FALSE	-3	Int32
DR-02	Reference [%]	0.0 %	All set-ups	FALSE	-1	Int16
DR-03	Status Word	0 N/A	All set-ups	FALSE	0	V2
DR-05	Main Actual Value [%]	0.00 %	All set-ups	FALSE	-2	N2
DR-09	Custom Readout	0.00 CustomReadoutUnit	All set-ups	FALSE	-2	Int32
DR-1#						
DR-10	Power [kW]	0.00 kW	All set-ups	FALSE	1	Int32
DR-11	Power [hp]	0.00 hp	All set-ups	FALSE	-2	Int32
DR-12	Motor Voltage	0.0 V	All set-ups	FALSE	-1	UInt16
DR-13	Frequency	0.0 Hz	All set-ups	FALSE	-1	UInt16
DR-14	Motor Current	0.00 A	All set-ups	FALSE	-2	Int32
DR-15	Frequency [%]	0.00 %	All set-ups	FALSE	-2	N2
DR-16	Torque [Nm]	0.0 Nm	All set-ups	FALSE	-1	Int32
DR-17	Speed [RPM]	0 RPM	All set-ups	FALSE	67	Int32
DR-18	Motor Thermal	0 %	All set-ups	FALSE	0	UInt8
DR-2#						
DR-22	Torque [%]	0 %	All set-ups	FALSE	0	Int16
DR-3#						
DR-30	DC Link Voltage	0 V	All set-ups	FALSE	0	UInt16
DR-32	Brake Energy /s	0.000 kW	All set-ups	FALSE	0	UInt32
DR-33	Brake Energy /2 min	0.000 kW	All set-ups	FALSE	0	UInt32
DR-34	Heatsink Temp.	0 °C	All set-ups	FALSE	100	UInt8
DR-35	Drive Thermal	0 %	All set-ups	FALSE	0	UInt8
DR-36	Drive Nominal Current	ExpressionLimit	All set-ups	FALSE	-2	UInt32
DR-37	Drive Max. Current	ExpressionLimit	All set-ups	FALSE	-2	UInt32
DR-38	Logic Controller State	0 N/A	All set-ups	FALSE	0	UInt8
DR-39	Control Card Temp.	0 °C	All set-ups	FALSE	100	UInt8
DR-4#						
DR-40	Trending Buffer Full	[0] No	All set-ups	TRUE	-	UInt8
DR-43	Timed Actions Status	[0] Timed Actions Auto	All set-ups	TRUE	-	UInt8
DR-49	Current Fault Source	0 N/A	All set-ups	TRUE	0	UInt8
DR-5#						
DR-50	External Reference	0.0 N/A	All set-ups	FALSE	-1	Int16
DR-52	Feedback [Unit]	0.000 ProcessCtrlUnit	All set-ups	FALSE	-3	Int32
DR-53	Digi Pot Reference	0.00 N/A	All set-ups	FALSE	-2	Int16
DR-54	Feedback 1 [Unit]	0.000 ProcessCtrlUnit	All set-ups	FALSE	-3	Int32
DR-55	Feedback 2 [Unit]	0.000 ProcessCtrlUnit	All set-ups	FALSE	-3	Int32
DR-56	Feedback 3 [Unit]	0.000 ProcessCtrlUnit	All set-ups	FALSE	-3	Int32
DR-58	PID Output [%]	0.0 %	All set-ups	TRUE	-1	Int16
DR-6#						
DR-60	Digital Input	0 N/A	All set-ups	FALSE	0	UInt16
DR-61	Terminal 53 Switch Setting	[0] Current	All set-ups	FALSE	-	UInt8
DR-62	Analog Input 53	0.000 N/A	All set-ups	FALSE	-3	Int32
DR-63	Terminal 54 Switch Setting	[0] Current	All set-ups	FALSE	-	UInt8
DR-64	Analog Input 54	0.000 N/A	All set-ups	FALSE	-3	Int32
DR-65	Analog Output 42 [mA]	0.000 N/A	All set-ups	FALSE	-3	Int16



How to Program

AF-600 FP High Power Operating Instructions

Par. No. #	Parameter description	Default value	4-set-up	Change during operation	Conversion index	Type
DR-66	Digital Output [bin]	0 N/A	All set-ups	FALSE	0	Int16
DR-67	Freq. Input #29 [Hz]	0 N/A	All set-ups	FALSE	0	Int32
DR-68	Freq. Input #33 [Hz]	0 N/A	All set-ups	FALSE	0	Int32
DR-69	Pulse Output #27 [Hz]	0 N/A	All set-ups	FALSE	0	Int32
DR-7#						
DR-70	Pulse Output #29 [Hz]	0 N/A	All set-ups	FALSE	0	Int32
DR-71	Relay Output [bin]	0 N/A	All set-ups	FALSE	0	Int16
DR-72	Counter A	0 N/A	All set-ups	TRUE	0	Int32
DR-73	Counter B	0 N/A	All set-ups	TRUE	0	Int32
DR-75	Analog In X30/11	0.000 N/A	All set-ups	FALSE	-3	Int32
DR-76	Analog In X30/12	0.000 N/A	All set-ups	FALSE	-3	Int32
DR-77	Analog Out X30/8 [mA]	0.000 N/A	All set-ups	FALSE	-3	Int16
DR-8#						
DR-80	Fieldbus CTW 1	0 N/A	All set-ups	FALSE	0	V2
DR-82	Fieldbus REF 1	0 N/A	All set-ups	FALSE	0	N2
DR-84	Comm. Option STW	0 N/A	All set-ups	FALSE	0	V2
DR-85	Drive Port CTW 1	0 N/A	All set-ups	FALSE	0	V2
DR-86	Drive Port REF 1	0 N/A	All set-ups	FALSE	0	N2
DR-9#						
DR-90	Alarm Word	0 N/A	All set-ups	FALSE	0	Uint32
DR-91	Alarm Word 2	0 N/A	All set-ups	FALSE	0	Uint32
DR-92	Warning Word	0 N/A	All set-ups	FALSE	0	Uint32
DR-93	Warning Word 2	0 N/A	All set-ups	FALSE	0	Uint32
DR-94	Ext. Status Word	0 N/A	All set-ups	FALSE	0	Uint32
DR-95	Ext. Status Word 2	0 N/A	All set-ups	FALSE	0	Uint32
DR-96	Maintenance Word	0 N/A	All set-ups	FALSE	0	Uint32



6.2.19 LG-## Logs & I/O Opt. Status

6

Par. No. #	Parameter description	Default value	4-set-up	Change during operation	Conversion index	Type
LG-0#						
LG-00	Maintenance Log: Item	0 N/A	All set-ups	FALSE	0	UInt8
LG-01	Maintenance Log: Action	0 N/A	All set-ups	FALSE	0	UInt8
LG-02	Maintenance Log: Time	0 s	All set-ups	FALSE	0	UInt32
LG-03	Maintenance Log: Date and Time	ExpressionLimit	All set-ups	FALSE	0	TimeOf Day
LG-1#						
LG-10	Fire Mode Log: Event	0 N/A	All set-ups	FALSE	0	UInt8
LG-11	Fire Mode Log: Time	0 s	All set-ups	FALSE	0	UInt32
LG-12	Fire Mode Log: Date and Time	ExpressionLimit	All set-ups	FALSE	0	TimeOf Day
LG-3#						
LG-30	Analog Input X42/1	0.000 N/A	All set-ups	FALSE	-3	Int32
LG-31	Analog Input X42/3	0.000 N/A	All set-ups	FALSE	-3	Int32
LG-32	Analog Input X42/5	0.000 N/A	All set-ups	FALSE	-3	Int32
LG-33	Analog Out X42/7 [V]	0.000 N/A	All set-ups	FALSE	-3	Int16
LG-34	Analog Out X42/9 [V]	0.000 N/A	All set-ups	FALSE	-3	Int16
LG-35	Analog Out X42/11 [V]	0.000 N/A	All set-ups	FALSE	-3	Int16



6.2.20 AP-## HVAC Appl. Param.

Par. No. #	Parameter description	Default value	4-set-up	Change during operation	Conversion index	Type
AP-0#						
AP-00	External Interlock Delay	0 s	All set-ups	TRUE	0	Uint16
AP-2#						
AP-20	Low Power Auto Set-up	[0] Off	All set-ups	FALSE	-	Uint8
AP-21	Low Power Detection	[0] Disabled	All set-ups	TRUE	-	Uint8
AP-22	Low Speed Detection	[0] Disabled	All set-ups	TRUE	-	Uint8
AP-23	No-Flow Function	[0] Off	All set-ups	TRUE	-	Uint8
AP-24	No-Flow Delay	10 s	All set-ups	TRUE	0	Uint16
AP-26	Dry Pump Function	[0] Off	All set-ups	TRUE	-	Uint8
AP-27	Dry Pump Delay	10 s	All set-ups	TRUE	0	Uint16
AP-3#						
AP-30	No-Flow Power	0.00 kW	All set-ups	TRUE	1	Uint32
AP-31	Power Correction Factor	100 %	All set-ups	TRUE	0	Uint16
AP-32	Low Speed [RPM]	ExpressionLimit	All set-ups	TRUE	67	Uint16
AP-33	Low Speed [Hz]	ExpressionLimit	All set-ups	TRUE	-1	Uint16
AP-34	Low Speed Power [kW]	ExpressionLimit	All set-ups	TRUE	1	Uint32
AP-35	Low Speed Power [HP]	ExpressionLimit	All set-ups	TRUE	-2	Uint32
AP-36	High Speed [RPM]	ExpressionLimit	All set-ups	TRUE	67	Uint16
AP-37	High Speed [Hz]	ExpressionLimit	All set-ups	TRUE	-1	Uint16
AP-38	High Speed Power [kW]	ExpressionLimit	All set-ups	TRUE	1	Uint32
AP-39	High Speed Power [HP]	ExpressionLimit	All set-ups	TRUE	-2	Uint32
AP-4#						
AP-40	Minimum Run Time	10 s	All set-ups	TRUE	0	Uint16
AP-41	Minimum Sleep Time	10 s	All set-ups	TRUE	0	Uint16
AP-42	Wake-up Speed [RPM]	ExpressionLimit	All set-ups	TRUE	67	Uint16
AP-43	Wake-up Speed [Hz]	ExpressionLimit	All set-ups	TRUE	-1	Uint16
AP-44	Wake-up Ref./FB Difference	10 %	All set-ups	TRUE	0	Int8
AP-45	Setpoint Boost	0 %	All set-ups	TRUE	0	Int8
AP-46	Maximum Boost Time	60 s	All set-ups	TRUE	0	Uint16
AP-5#						
AP-50	End of Curve Function	[0] Off	All set-ups	TRUE	-	Uint8
AP-51	End of Curve Delay	10 s	All set-ups	TRUE	0	Uint16
AP-6#						
AP-60	Broken Belt Function	[0] Off	All set-ups	TRUE	-	Uint8
AP-61	Broken Belt Torque	10 %	All set-ups	TRUE	0	Uint8
AP-62	Broken Belt Delay	10 s	All set-ups	TRUE	0	Uint16
AP-7#						
AP-70	Compressor Start Max Speed [RPM]	ExpressionLimit	All set-ups	TRUE	67	Uint16
AP-71	Compressor Start Max Speed [Hz]	ExpressionLimit	All set-ups	TRUE	-1	Uint16
AP-72	Compressor Start Max Time to Trip	5.0 s	All set-ups	TRUE	-1	Uint8
AP-73	Starting Acceleration Time	ExpressionLimit	2 set-ups	TRUE	-2	Uint32
AP-75	Short Cycle Protection	[0] Disabled	All set-ups	TRUE	-	Uint8
AP-76	Interval between Starts	ExpressionLimit	All set-ups	TRUE	0	Uint16
AP-77	Minimum Run Time	0 s	All set-ups	TRUE	0	Uint16
AP-8#						
AP-80	Flow Compensation	[0] Disabled	All set-ups	TRUE	-	Uint8
AP-81	Square-linear Curve Approximation	100 %	All set-ups	TRUE	0	Uint8
AP-82	Work Point Calculation	[0] Disabled	All set-ups	TRUE	-	Uint8
AP-83	Speed at No-Flow [RPM]	ExpressionLimit	All set-ups	TRUE	67	Uint16

**How to Program****AF-600 FP High Power Operating Instructions**

Par. No. #	Parameter description	Default value	4-set-up	Change during operation	Conversion index	Type
AP-84	Speed at No-Flow [Hz]	ExpressionLimit	All set-ups	TRUE	-1	Uint16
AP-85	Speed at Design Point [RPM]	ExpressionLimit	All set-ups	TRUE	67	Uint16
AP-86	Speed at Design Point [Hz]	ExpressionLimit	All set-ups	TRUE	-1	Uint16
AP-87	Pressure at No-Flow Speed	0.000 N/A	All set-ups	TRUE	-3	Int32
AP-88	Pressure at Rated Speed	999999.999 N/A	All set-ups	TRUE	-3	Int32
AP-89	Flow at Design Point	0.000 N/A	All set-ups	TRUE	-3	Int32
AP-9#						
AP-90	Flow at Rated Speed	0.000 N/A	All set-ups	TRUE	-3	Int32



6.2.21 FB-## Fire/Bypass Operation

Par. No. #	Parameter description	Default value	4-set-up	Change during operation	Conversion index	Type
FB-0#						
FB-00	Fire Mode Function	[0] Disabled	2 set-ups	TRUE	-	Uint8
FB-01	Fire Mode Configuration	[0] Open Loop	All set-ups	TRUE	-	Uint8
FB-02	Fire Mode Unit	null	All set-ups	TRUE	-	Uint8
FB-03	Fire Mode Min Reference	ExpressionLimit	All set-ups	TRUE	-3	Int32
FB-04	Fire Mode Max Reference	ExpressionLimit	All set-ups	TRUE	-3	Int32
FB-05	Fire Mode Preset Reference	0.00 %	All set-ups	TRUE	-2	Int16
FB-06	Fire Mode Reference Source	[0] No function	All set-ups	TRUE	-	Uint8
FB-07	Fire Mode Feedback Source	[0] No function	All set-ups	TRUE	-	Uint8
FB-09	Fire Mode Alarm Handling	[1] Trip, Critical Alarms	2 set-ups	FALSE	-	Uint8
FB-1#						
FB-10	Drive Bypass Function	[0] Disabled	2 set-ups	TRUE	-	Uint8
FB-11	Drive Bypass Delay Time	0 s	2 set-ups	TRUE	0	Uint16
FB-2#						
FB-20	Locked Rotor Function	[0] Off	All set-ups	TRUE	-	Uint8
FB-21	Locked Rotor Coefficient 1	0.0000 N/A	All set-ups	TRUE	-4	Int32
FB-22	Locked Rotor Coefficient 2	0.0000 N/A	All set-ups	TRUE	-4	Int32
FB-23	Locked Rotor Coefficient 3	0.0000 N/A	All set-ups	TRUE	-4	Int32
FB-24	Locked Rotor Coefficient 4	0.000 N/A	All set-ups	TRUE	-3	Int32
FB-3#						
FB-30	Missing Motor Function	[0] Off	All set-ups	TRUE	-	Uint8
FB-31	Missing Motor Coefficient 1	0.0000 N/A	All set-ups	TRUE	-4	Int32
FB-32	Missing Motor Coefficient 2	0.0000 N/A	All set-ups	TRUE	-4	Int32
FB-33	Missing Motor Coefficient 3	0.0000 N/A	All set-ups	TRUE	-4	Int32
FB-34	Missing Motor Coefficient 4	0.000 N/A	All set-ups	TRUE	-3	Int32



6.2.22 T-## Timed Functions

6

Par. No. #	Parameter description	Default value	4-set-up	Change during operation	Conversion index	Type
T-0#						
T-00	ON Time	ExpressionLimit	2 set-ups	TRUE	0	TimeOfDay-WoDate
T-01	ON Action	[0] Disabled	2 set-ups	TRUE	-	UInt8
T-02	OFF Time	ExpressionLimit	2 set-ups	TRUE	0	TimeOfDay-WoDate
T-03	OFF Action	[1] No action	2 set-ups	TRUE	-	UInt8
T-04	Occurrence	[0] All days	2 set-ups	TRUE	-	UInt8
T-08	Timed Actions Mode	[0] Timed Actions Auto	2 set-ups	TRUE	-	UInt8
T-09	Timed Actions Reactivation	[1] Enabled	2 set-ups	TRUE	-	UInt8
T-1#						
T-10	Maintenance Item	[1] Motor bearings	1 set-up	TRUE	-	UInt8
T-11	Maintenance Action	[1] Lubricate	1 set-up	TRUE	-	UInt8
T-12	Maintenance Time Base	[0] Disabled	1 set-up	TRUE	-	UInt8
T-13	Maintenance Time Interval	1 h	1 set-up	TRUE	74	UInt32
T-14	Maintenance Date and Time	ExpressionLimit	1 set-up	TRUE	0	TimeOfDay
T-15	Reset Maintenance Word	[0] Do not reset	All set-ups	TRUE	-	UInt8
T-16	Maintenance Text	0 N/A	1 set-up	TRUE	0	VisStr[20]
T-5#						
T-50	Energy Log Resolution	[5] Last 24 Hours	2 set-ups	TRUE	-	UInt8
T-51	Period Start	ExpressionLimit	2 set-ups	TRUE	0	TimeOfDay
T-53	Energy Log	0 N/A	All set-ups	TRUE	0	UInt32
T-54	Reset Energy Log	[0] Do not reset	All set-ups	TRUE	-	UInt8
T-6#						
T-60	Trend Variable	[0] Power [kW]	2 set-ups	TRUE	-	UInt8
T-61	Continuous Bin Data	0 N/A	All set-ups	TRUE	0	UInt32
T-62	Timed Bin Data	0 N/A	All set-ups	TRUE	0	UInt32
T-63	Timed Period Start	ExpressionLimit	2 set-ups	TRUE	0	TimeOfDay
T-64	Timed Period Stop	ExpressionLimit	2 set-ups	TRUE	0	TimeOfDay
T-65	Minimum Bin Value	ExpressionLimit	2 set-ups	TRUE	0	UInt8
T-66	Reset Continuous Bin Data	[0] Do not reset	All set-ups	TRUE	-	UInt8
T-67	Reset Timed Bin Data	[0] Do not reset	All set-ups	TRUE	-	UInt8
T-8#						
T-80	Power Reference Factor	100 %	2 set-ups	TRUE	0	UInt8
T-81	Energy Cost	1.00 N/A	2 set-ups	TRUE	-2	UInt32
T-82	Investment	0 N/A	2 set-ups	TRUE	0	UInt32
T-83	Energy Savings	0 kWh	All set-ups	TRUE	75	Int32
T-84	Cost Savings	0 N/A	All set-ups	TRUE	0	Int32



6.2.23 CL-## PID Closed Loop

Par. No. #	Parameter description	Default value	4-set-up	Change during operation	Conversion index	Type
CL-0#						
CL-00	Feedback 1 Source	[2] Analog input 54	All set-ups	TRUE	-	UInt8
CL-01	Feedback 1 Conversion	[0] Linear	All set-ups	FALSE	-	UInt8
CL-02	Feedback 1 Source Unit	null	All set-ups	TRUE	-	UInt8
CL-03	Feedback 2 Source	[0] No function	All set-ups	TRUE	-	UInt8
CL-04	Feedback 2 Conversion	[0] Linear	All set-ups	FALSE	-	UInt8
CL-05	Feedback 2 Source Unit	null	All set-ups	TRUE	-	UInt8
CL-06	Feedback 3 Source	[0] No function	All set-ups	TRUE	-	UInt8
CL-07	Feedback 3 Conversion	[0] Linear	All set-ups	FALSE	-	UInt8
CL-08	Feedback 3 Source Unit	null	All set-ups	TRUE	-	UInt8
CL-1#						
CL-12	Reference/Feedback Unit	null	All set-ups	TRUE	-	UInt8
CL-13	Minimum Reference/Feedb.	0.000 ProcessCtrlUnit	All set-ups	TRUE	-3	Int32
CL-14	Maximum Reference/Feedb.	100.000 ProcessCtrlUnit	All set-ups	TRUE	-3	Int32
CL-2#						
CL-20	Feedback Function	[3] Minimum	All set-ups	TRUE	-	UInt8
CL-21	Setpoint 1	0.000 ProcessCtrlUnit	All set-ups	TRUE	-3	Int32
CL-22	Setpoint 2	0.000 ProcessCtrlUnit	All set-ups	TRUE	-3	Int32
CL-23	Setpoint 3	0.000 ProcessCtrlUnit	All set-ups	TRUE	-3	Int32
CL-3#						
CL-30	Refrigerant	[0] R22	All set-ups	TRUE	-	UInt8
CL-31	User Defined Refrigerant A1	10.0000 N/A	All set-ups	TRUE	-4	UInt32
CL-32	User Defined Refrigerant A2	-2250.00 N/A	All set-ups	TRUE	-2	Int32
CL-33	User Defined Refrigerant A3	250.000 N/A	All set-ups	TRUE	-3	UInt32
CL-34	Duct 1 Area [m2]	0.500 m2	All set-ups	TRUE	-3	UInt32
CL-35	Duct 1 Area [in2]	750 in2	All set-ups	TRUE	0	UInt32
CL-36	Duct 2 Area [m2]	0.500 m2	All set-ups	TRUE	-3	UInt32
CL-37	Duct 2 Area [in2]	750 in2	All set-ups	TRUE	0	UInt32
CL-38	Air Density Factor [%]	100 %	All set-ups	TRUE	0	UInt32
CL-7#						
CL-70	Closed Loop Type	[0] Auto	2 set-ups	TRUE	-	UInt8
CL-71	PID Performance	[0] Normal	2 set-ups	TRUE	-	UInt8
CL-72	PID Output Change	0.10 N/A	2 set-ups	TRUE	-2	UInt16
CL-73	Minimum Feedback Level	-999999.000 ProcessCtrlUnit	2 set-ups	TRUE	-3	Int32
CL-74	Maximum Feedback Level	999999.000 ProcessCtrlUnit	2 set-ups	TRUE	-3	Int32
CL-79	PID Autotuning	[0] Disabled	All set-ups	TRUE	-	UInt8
CL-8#						
CL-81	PID Normal/ Inverse Control	[0] Normal	All set-ups	TRUE	-	UInt8
CL-82	PID Start Speed [RPM]	ExpressionLimit	All set-ups	TRUE	67	UInt16
CL-83	PID Start Speed [Hz]	ExpressionLimit	All set-ups	TRUE	-1	UInt16
CL-84	On Reference Bandwidth	5 %	All set-ups	TRUE	0	UInt8
CL-9#						
CL-91	PID Anti Windup	[1] On	All set-ups	TRUE	-	UInt8
CL-93	PID Proportional Gain	0.50 N/A	All set-ups	TRUE	-2	UInt16
CL-94	PID Integral Time	20.00 s	All set-ups	TRUE	-2	UInt32
CL-95	PID Differentiation Time	0.00 s	All set-ups	TRUE	-2	UInt16
CL-96	PID Diff. Gain Limit	5.0 N/A	All set-ups	TRUE	-1	UInt16



6.2.24 XC-## Ext. PID Closed Loop

6

Par. No. #	Parameter description	Default value	4-set-up	Change during operation	Conversion index	Type
XC-0#						
XC-00	Closed Loop Type	[0] Auto	2 set-ups	TRUE	-	UInt8
XC-01	PID Performance	[0] Normal	2 set-ups	TRUE	-	UInt8
XC-02	PID Output Change	0.10 N/A	2 set-ups	TRUE	-2	UInt16
XC-03	Minimum Feedback Level	-999999.000 N/A	2 set-ups	TRUE	-3	Int32
XC-04	Maximum Feedback Level	999999.000 N/A	2 set-ups	TRUE	-3	Int32
XC-09	PID Autotuning	[0] Disabled	All set-ups	TRUE	-	UInt8
XC-1#						
XC-10	Ext. 1 Ref./Feedback Unit	[1] %	All set-ups	TRUE	-	UInt8
XC-11	Ext. 1 Minimum Reference	0.000 ExtPID1Unit	All set-ups	TRUE	-3	Int32
XC-12	Ext. 1 Maximum Reference	100.000 ExtPID1Unit	All set-ups	TRUE	-3	Int32
XC-13	Ext. 1 Reference Source	[0] No function	All set-ups	TRUE	-	UInt8
XC-14	Ext. 1 Feedback Source	[0] No function	All set-ups	TRUE	-	UInt8
XC-15	Ext. 1 Setpoint	0.000 ExtPID1Unit	All set-ups	TRUE	-3	Int32
XC-17	Ext. 1 Reference [Unit]	0.000 ExtPID1Unit	All set-ups	TRUE	-3	Int32
XC-18	Ext. 1 Feedback [Unit]	0.000 ExtPID1Unit	All set-ups	TRUE	-3	Int32
XC-19	Ext. 1 Output [%]	0 %	All set-ups	TRUE	0	Int32
XC-2#						
XC-20	Ext. 1 Normal/Inverse Control	[0] Normal	All set-ups	TRUE	-	UInt8
XC-21	Ext. 1 Proportional Gain	0.01 N/A	All set-ups	TRUE	-2	UInt16
XC-22	Ext. 1 Integral Time	10000.00 s	All set-ups	TRUE	-2	UInt32
XC-23	Ext. 1 Differentiation Time	0.00 s	All set-ups	TRUE	-2	UInt16
XC-24	Ext. 1 Dif. Gain Limit	5.0 N/A	All set-ups	TRUE	-1	UInt16
XC-3#						
XC-30	Ext. 2 Ref./Feedback Unit	[1] %	All set-ups	TRUE	-	UInt8
XC-31	Ext. 2 Minimum Reference	0.000 ExtPID2Unit	All set-ups	TRUE	-3	Int32
XC-32	Ext. 2 Maximum Reference	100.000 ExtPID2Unit	All set-ups	TRUE	-3	Int32
XC-33	Ext. 2 Reference Source	[0] No function	All set-ups	TRUE	-	UInt8
XC-34	Ext. 2 Feedback Source	[0] No function	All set-ups	TRUE	-	UInt8
XC-35	Ext. 2 Setpoint	0.000 ExtPID2Unit	All set-ups	TRUE	-3	Int32
XC-37	Ext. 2 Reference [Unit]	0.000 ExtPID2Unit	All set-ups	TRUE	-3	Int32
XC-38	Ext. 2 Feedback [Unit]	0.000 ExtPID2Unit	All set-ups	TRUE	-3	Int32
XC-39	Ext. 2 Output [%]	0 %	All set-ups	TRUE	0	Int32
XC-4#						
XC-40	Ext. 2 Normal/Inverse Control	[0] Normal	All set-ups	TRUE	-	UInt8
XC-41	Ext. 2 Proportional Gain	0.01 N/A	All set-ups	TRUE	-2	UInt16
XC-42	Ext. 2 Integral Time	10000.00 s	All set-ups	TRUE	-2	UInt32
XC-43	Ext. 2 Differentiation Time	0.00 s	All set-ups	TRUE	-2	UInt16
XC-44	Ext. 2 Dif. Gain Limit	5.0 N/A	All set-ups	TRUE	-1	UInt16
XC-5#						
XC-50	Ext. 3 Ref./Feedback Unit	[1] %	All set-ups	TRUE	-	UInt8
XC-51	Ext. 3 Minimum Reference	0.000 ExtPID3Unit	All set-ups	TRUE	-3	Int32
XC-52	Ext. 3 Maximum Reference	100.000 ExtPID3Unit	All set-ups	TRUE	-3	Int32
XC-53	Ext. 3 Reference Source	[0] No function	All set-ups	TRUE	-	UInt8
XC-54	Ext. 3 Feedback Source	[0] No function	All set-ups	TRUE	-	UInt8
XC-55	Ext. 3 Setpoint	0.000 ExtPID3Unit	All set-ups	TRUE	-3	Int32
XC-57	Ext. 3 Reference [Unit]	0.000 ExtPID3Unit	All set-ups	TRUE	-3	Int32
XC-58	Ext. 3 Feedback [Unit]	0.000 ExtPID3Unit	All set-ups	TRUE	-3	Int32
XC-59	Ext. 3 Output [%]	0 %	All set-ups	TRUE	0	Int32

**How to Program****AF-600 FP High Power Operating Instructions**

Par. No. #	Parameter description	Default value	4-set-up	Change during operation	Conversion index	Type
XC-6#						
XC-60	Ext. 3 Normal/Inverse Control	[0] Normal	All set-ups	TRUE	-	Uint8
XC-61	Ext. 3 Proportional Gain	0.01 N/A	All set-ups	TRUE	-2	Uint16
XC-62	Ext. 3 Integral Time	10000.00 s	All set-ups	TRUE	-2	Uint32
XC-63	Ext. 3 Differentation Time	0.00 s	All set-ups	TRUE	-2	Uint16
XC-64	Ext. 3 Dif. Gain Limit	5.0 N/A	All set-ups	TRUE	-1	Uint16



6.2.25 PC-## Pump Controller

6

Par. No. #	Parameter description	Default value	4-set-up	Change during operation	Conversion index	Type
PC-0#						
PC-00	Pump Controller	[0] Disabled	2 set-ups	FALSE	-	Uint8
PC-02	Motor Start	[0] Direct on Line	2 set-ups	FALSE	-	Uint8
PC-04	Pump Cycling	[0] Disabled	All set-ups	TRUE	-	Uint8
PC-05	Fixed Lead Pump	[1] Yes	2 set-ups	FALSE	-	Uint8
PC-06	Number of Pumps	2 N/A	2 set-ups	FALSE	0	Uint8
PC-1#						
PC-10	Minimum Run Time Override	[0] Disabled	All set-ups	FALSE	-	Uint8
PC-11	Minimum Run Time Override Value	0.000 ProcessCtrlUnit	All set-ups	TRUE	-3	Int32
PC-2#						
PC-20	Staging Bandwidth	10 %	All set-ups	TRUE	0	Uint8
PC-21	Override Bandwidth	100 %	All set-ups	TRUE	0	Uint8
PC-22	Fixed Speed Bandwidth	casco_staging_bandwidth (P2520)	All set-ups	TRUE	0	Uint8
PC-23	SBW Staging Delay	15 s	All set-ups	TRUE	0	Uint16
PC-24	SBW Destaging Delay	15 s	All set-ups	TRUE	0	Uint16
PC-25	OBW Time	10 s	All set-ups	TRUE	0	Uint16
PC-26	Destage At No-Flow	[0] Disabled	All set-ups	TRUE	-	Uint8
PC-27	Stage Function	[1] Enabled	All set-ups	TRUE	-	Uint8
PC-28	Stage Function Time	15 s	All set-ups	TRUE	0	Uint16
PC-29	Destage Function	[1] Enabled	All set-ups	TRUE	-	Uint8
PC-3#						
PC-30	Destage Function Time	15 s	All set-ups	TRUE	0	Uint16
PC-4#						
PC-40	Decel Ramp Delay	10.0 s	All set-ups	TRUE	-1	Uint16
PC-41	Accel Ramp Delay	2.0 s	All set-ups	TRUE	-1	Uint16
PC-42	Staging Threshold	ExpressionLimit	All set-ups	TRUE	0	Uint8
PC-43	Destaging Threshold	ExpressionLimit	All set-ups	TRUE	0	Uint8
PC-44	Staging Speed [RPM]	0 RPM	All set-ups	TRUE	67	Uint16
PC-45	Staging Speed [Hz]	0.0 Hz	All set-ups	TRUE	-1	Uint16
PC-46	Destaging Speed [RPM]	0 RPM	All set-ups	TRUE	67	Uint16
PC-47	Destaging Speed [Hz]	0.0 Hz	All set-ups	TRUE	-1	Uint16
PC-5#						
PC-50	Lead Pump Alternation	[0] Off	All set-ups	TRUE	-	Uint8
PC-51	Alternation Event	[0] External	All set-ups	TRUE	-	Uint8
PC-52	Alternation Time Interval	24 h	All set-ups	TRUE	74	Uint16
PC-53	Alternation Timer Value	0 N/A	All set-ups	TRUE	0	VisStr[7]
PC-54	Alternation Predefined Time	ExpressionLimit	All set-ups	TRUE	0	TimeOfDay-WoDate
PC-55	Alternate if Load < 50%	[1] Enabled	All set-ups	TRUE	-	Uint8
PC-56	Staging Mode at Alternation	[0] Slow	All set-ups	TRUE	-	Uint8
PC-58	Run Next Pump Delay	0.1 s	All set-ups	TRUE	-1	Uint16
PC-59	Run on Line Delay	0.5 s	All set-ups	TRUE	-1	Uint16
PC-8#						
PC-80	Pump Status	0 N/A	All set-ups	TRUE	0	VisStr[25]
PC-81	Pump Status	0 N/A	All set-ups	TRUE	0	VisStr[25]
PC-82	Lead Pump	0 N/A	All set-ups	TRUE	0	Uint8
PC-83	Relay Status	0 N/A	All set-ups	TRUE	0	VisStr[4]
PC-84	Pump ON Time	0 h	All set-ups	TRUE	74	Uint32

**How to Program****AF-600 FP High Power Operating Instructions**

Par. No. #	Parameter description	Default value	4-set-up	Change during operation	Conversion index	Type
PC-85	Relay ON Time	0 h	All set-ups	TRUE	74	Uint32
PC-86	Reset Relay Counters	[0] Do not reset	All set-ups	TRUE	-	Uint8
PC-9#						
PC-90	Pump Interlock	[0] Off	All set-ups	TRUE	-	Uint8
PC-91	Manual Alternation	0 N/A	All set-ups	TRUE	0	Uint8



6.2.26 LC-## Logic Controller

Par. No. #	Parameter description	Default value	4-set-up	Change during operation	Conversion index	Type
LC-0#						
LC-00	Logic Controller Mode	null	2 set-ups	TRUE	-	UInt8
LC-01	Start Event	null	2 set-ups	TRUE	-	UInt8
LC-02	Stop Event	null	2 set-ups	TRUE	-	UInt8
LC-03	Reset Logic Controller	[0] Do not reset Logic Controller	All set-ups	TRUE	-	UInt8
LC-1#						
LC-10	Comparator Operand	null	2 set-ups	TRUE	-	UInt8
LC-11	Comparator Operator	null	2 set-ups	TRUE	-	UInt8
LC-12	Comparator Value	ExpressionLimit	2 set-ups	TRUE	-3	Int32
LC-2#						
LC-20	Logic Controller Timer	ExpressionLimit	1 set-up	TRUE	-3	TimD
LC-4#						
LC-40	Logic Rule Boolean 1	null	2 set-ups	TRUE	-	UInt8
LC-41	Logic Rule Operator 1	null	2 set-ups	TRUE	-	UInt8
LC-42	Logic Rule Boolean 2	null	2 set-ups	TRUE	-	UInt8
LC-43	Logic Rule Operator 2	null	2 set-ups	TRUE	-	UInt8
LC-44	Logic Rule Boolean 3	null	2 set-ups	TRUE	-	UInt8
LC-5#						
LC-51	Logic Controller Event	null	2 set-ups	TRUE	-	UInt8
LC-52	Logic Controller Action	null	2 set-ups	TRUE	-	UInt8

6.2.27 B-## Braking Functions

Par. No. #	Parameter description	Default value	4-set-up	Change during operation	Conversion index	Type
B-0#						
B-00	DC Hold Current	50 %	All set-ups	TRUE	0	UInt8
B-01	DC Brake Current	50 %	All set-ups	TRUE	0	UInt16
B-02	DC Braking Time	10.0 s	All set-ups	TRUE	-1	UInt16
B-03	DC Brake Cut In Speed [RPM]	ExpressionLimit	All set-ups	TRUE	67	UInt16
B-04	DC Brake Cut In Speed [Hz]	ExpressionLimit	All set-ups	TRUE	-1	UInt16
B-1#						
B-10	Brake Function	[0] Off	All set-ups	TRUE	-	UInt8
B-16	AC brake Max. Current	100.0 %	All set-ups	TRUE	-1	UInt32
B-17	Over-voltage Control	[2] Enabled	All set-ups	TRUE	-	UInt8



7 General Specifications

Mains supply (L1, L2, L3):

Supply voltage	380-480V $\pm 10\%$
Supply voltage	525-600 V $\pm 10\%$

Mains voltage low / mains drop-out:

During low mains voltage or a mains drop-out, the drive continues until the intermediate circuit voltage drops below the minimum stop level, which corresponds typically to 15% below the drive's lowest rated supply voltage. Power-up and full torque cannot be expected at mains voltage lower than 10% below the drive's lowest rated supply voltage.

Supply frequency	50/60Hz $\pm 5\%$
Max. imbalance temporary between mains phases	3.0 % of rated supply voltage
True Power Factor (λ)	≥ 0.9 nominal at rated load
Displacement Power Factor ($\cos\phi$) near unity	(> 0.98)
Switching on input supply L1, L2, L3 (power-ups)	maximum once/2 min.
Environment according to EN60664-1	overvoltage category III / pollution degree 2

The unit is suitable for use on a circuit capable of delivering not more than 100k RMS symmetrical Amperes, 480/600V maximum.

Motor output (U, V, W):

Output voltage	0 - 100% of supply voltage
Output frequency	0 - 800* Hz
Switching on output	Unlimited
Accel/Decel Times	1 - 3600 sec.

* Voltage and power dependent

Torque characteristics:

Starting torque (Constant torque)	maximum 110% for 1 min.*
Starting torque	maximum 135% up to 0.5 sec.*
Overload torque (Constant torque)	maximum 110% for 1 min.*

*Percentage relates to AF-600 FP Drive's nominal torque.

Cable lengths and cross sections:

Max. motor cable length, screened/armoured	150 m
Max. motor cable length, unscreened/unarmoured	300 m
Max. cross section to motor, mains and brake *	
Maximum cross section to control terminals, rigid wire	1.5 mm ² /16 AWG (2 x 0.75 mm ²)
Maximum cross section to control terminals, flexible cable	1 mm ² /18 AWG
Maximum cross section to control terminals, cable with enclosed core	0.5 mm ² /20 AWG
Minimum cross section to control terminals	0.25 mm ²

* See Mains Supply tables for more information!

Digital inputs:

Programmable digital inputs	4 (6)
Terminal number	18, 19, 27 ¹⁾ , 29, 32, 33,
Logic	PNP or NPN
Voltage level	0 - 24V DC
Voltage level, logic '0' PNP	< 5 V DC
Voltage level, logic '1' PNP	> 10 V DC
Voltage level, logic '0' NPN	> 19 V DC
Voltage level, logic '1' NPN	< 14 V DC
Maximum voltage on input	28 V DC
Input resistance, R _i	approx. 4 k Ω

All digital inputs are galvanically isolated from the supply voltage (PELV) and other high-voltage terminals.

1) Terminals 27 and 29 can also be programmed as output.



General Specifications

AF-600 FP High Power Operating Instructions

Analog inputs:

Number of analog inputs	2
Terminal number	53, 54
Modes	Voltage or current
Mode select	Switch S201 and switch S202
Voltage mode	Switch S201/switch S202 = OFF (U)
Voltage level	: 0 to + 10V (scaleable)
Input resistance, R_i	approx. 10 k Ω
Max. voltage	\pm 20V
Current mode	Switch S201/switch S202 = ON (I)
Current level	0/4 to 20mA (scaleable)
Input resistance, R_i	approx. 200 Ω
Max. current	30mA
Resolution for analog inputs	10 bit (+ sign)
Accuracy of analog inputs	Max. error 0.5% of full scale
Bandwidth	200Hz

The analog inputs are galvanically isolated from the supply voltage (PELV) and other high-voltage terminals.

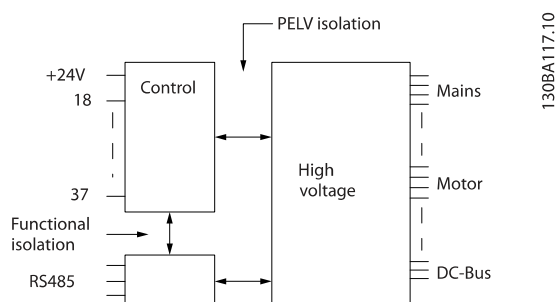

Pulse inputs:

Programmable pulse inputs	2
Terminal number pulse	29, 33
Max. frequency at terminal, 29, 33	110kHz (Push-pull driven)
Max. frequency at terminal, 29, 33	5kHz (open collector)
Min. frequency at terminal 29, 33	4Hz
Voltage level	see section on Digital input
Maximum voltage on input	28V DC
Input resistance, R_i	approx. 4k Ω
Pulse input accuracy (0.1 - 1 kHz)	Max. error: 0.1% of full scale

Analog output:

Number of programmable analog outputs	1
Terminal number	42
Current range at analog output	0/4 - 20mA
Max. resistor load to common at analog output	500 Ω
Accuracy on analog output	Max. error: 0.8% of full scale
Resolution on analog output	8 bit

The analog output is galvanically isolated from the supply voltage (PELV) and other high-voltage terminals.

Control card, serial communication:

Terminal number	68 (P,TX+, RX+), 69 (N,TX-, RX-)
Terminal number 61	Common for terminals 68 and 69

The serial communication circuit is functionally seated from other central circuits and galvanically isolated from the supply voltage (PELV).



General Specifications

AF-600 FP High Power Operating Instructions

Digital output:

Programmable digital/pulse outputs	2
Terminal number	27, 29 ¹⁾
Voltage level at digital/frequency output	0 - 24V
Max. output current (sink or source)	40mA
Max. load at frequency output	1 k Ω
Max. capacitive load at frequency output	10nF
Minimum output frequency at frequency output	0Hz
Maximum output frequency at frequency output	32kHz
Accuracy of frequency output	Max. error: 0.1% of full scale
Resolution of frequency outputs	12 bit

1) Terminal 27 and 29 can also be programmed as input.

The digital output is galvanically isolated from the supply voltage (PELV) and other high-voltage terminals.

Control card, 24 V DC output:

Terminal number	12, 13
Max. load	200mA

The 24V DC supply is galvanically isolated from the supply voltage (PELV), but has the same potential as the analog and digital inputs and outputs.

Relay outputs:

Programmable relay outputs	2
Relay 01 Terminal number	1-3 (break), 1-2 (make)
Max. terminal load (AC-1) ¹⁾ on 1-3 (NC), 1-2 (NO) (Resistive load)	240V AC, 2A
Max. terminal load (AC-15) ¹⁾ (Inductive load @ $\cos\phi$ 0.4)	240V AC, 0.2 A
Max. terminal load (DC-1) ¹⁾ on 1-2 (NO), 1-3 (NC) (Resistive load)	60V DC, 1A
Max. terminal load (DC-13) ¹⁾ (Inductive load)	24V DC, 0.1A
Relay 02 Terminal number	4-6 (break), 4-5 (make)
Max. terminal load (AC-1) ¹⁾ on 4-5 (NO) (Resistive load) ²⁾³⁾	400V AC, 2 A
Max. terminal load (AC-15) ¹⁾ on 4-5 (NO) (Inductive load @ $\cos\phi$ 0.4)	240V AC, 0.2 A
Max. terminal load (DC-1) ¹⁾ on 4-5 (NO) (Resistive load)	80V DC, 2 A
Max. terminal load (DC-13) ¹⁾ on 4-5 (NO) (Inductive load)	24V DC, 0.1A
Max. terminal load (AC-1) ¹⁾ on 4-6 (NC) (Resistive load)	240V AC, 2 A
Max. terminal load (AC-15) ¹⁾ on 4-6 (NC) (Inductive load @ $\cos\phi$ 0.4)	240V AC, 0.2A
Max. terminal load (DC-1) ¹⁾ on 4-6 (NC) (Resistive load)	50V DC, 2 A
Max. terminal load (DC-13) ¹⁾ on 4-6 (NC) (Inductive load)	24V DC, 0.1 A
Min. terminal load on 1-3 (NC), 1-2 (NO), 4-6 (NC), 4-5 (NO)	24V DC 10mA, 24V AC 20mA
Environment according to EN 60664-1	overvoltage category III/pollution degree 2

1) IEC 60947 parts 4 and 5

The relay contacts are galvanically isolated from the rest of the circuit by reinforced isolation (PELV).

2) Overvoltage Category II

3) UL applications 300V AC 2A

Control card, 10 V DC output:

Terminal number	50
Output voltage	10.5V \pm 0.5V
Max. load	25mA

The 10V DC supply is galvanically isolated from the supply voltage (PELV) and other high-voltage terminals.

Control characteristics:

Resolution of output frequency at 0 - 1000Hz	+/- 0.003Hz
System response time (terminals 18, 19, 27, 29, 32, 33)	\leq 2ms
Speed control range (open loop)	1:100 of synchronous speed
Speed accuracy (open loop)	30 - 4000 rpm: Maximum error of \pm 8 rpm

All control characteristics are based on a 4-pole asynchronous motor



General Specifications

AF-600 FP High Power Operating Instructions

Surroundings:

Enclosure, frame size 4X and 5X	IP 00, IP 21, IP 54
Enclosure, frame size 6X	IP 21, IP 54
Vibration test	0.7 g
Relative humidity	5% - 95%(IEC 721-3-3; Class 3K3 (non-condensing) during operation
Aggressive environment (IEC 60068-2-43) H ₂ S test	class kD
Test method according to IEC 60068-2-43 H ₂ S (10 days)	
- with derating	max. 55 ° C ¹⁾
- with full output power, typical EFF2 motors	max. 50 ° C ¹⁾
- at full continuous drive output current	max. 45 ° C ¹⁾

¹⁾ For more information on derating see the AF-600 FP, section on Special Conditions.

Minimum ambient temperature during full-scale operation	0 °C
Minimum ambient temperature at reduced performance	- 10 °C
Temperature during storage/transport	-25 - +65/70 °C
Maximum altitude above sea level without derating	1000 m
Maximum altitude above sea level with derating	3000 m

Derating for high altitude, see section on special conditions

EMC standards, Emission	EN 61800-3, EN 61000-6-3/4, EN 55011, IEC 61800-3 EN 61800-3, EN 61000-6-1/2,
EMC standards, Immunity	EN 61000-4-2, EN 61000-4-3, EN 61000-4-4, EN 61000-4-5, EN 61000-4-6

See section on special conditions!

Control card performance:

Scan interval	5ms
Control card, USB serial communication	
USB standard	1.1 (Full speed)
USB plug	USB type B "device" plug

CAUTION

Connection to PC is carried out via a standard host/device USB cable.

The USB connection is galvanically isolated from the supply voltage (PELV) and other high-voltage terminals.

The USB connection is not galvanically isolated from protection earth. Use only isolated laptop/PC as connection to the USB connector on the frequency converter or an isolated USB cable/converter.

Protection and Features:

- Electronic thermal motor protection against overload.
- Temperature monitoring of the heatsink ensures that the frequency converter trips if the temperature reaches a predefined level. An overload temperature cannot be reset until the temperature of the heatsink is below the values stated in the tables on the following pages (Guideline - these temperatures may vary for different power sizes, Unit Sizes, enclosure ratings etc.).
- The frequency converter is protected against short-circuits on motor terminals U, V, W.
- If a mains phase is missing, the frequency converter trips or issues a warning (depending on the load).
- Monitoring of the intermediate circuit voltage ensures that the frequency converter trips if the intermediate circuit voltage is too low or too high.
- The frequency converter is protected against earth faults on motor terminals U, V, W.



General Specifications

AF-600 FP High Power Operating Instructions

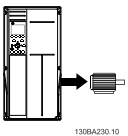
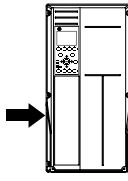
Mains Supply 3 x 380 - 480 VAC						
	Typical Shaft output at 400 V [kW]	110	132	160	200	250
	Typical Shaft output at 460 V [HP]	150	200	250	300	350
	Unit Size IP21	41	41	42	42	42
	Unit Size IP54	41	41	42	42	42
	Unit Size IP00	43	43	44	44	44
	Output current					
 130BA230.10	Continuous (at 400 V) [A]	212	260	315	395	480
	Intermittent (60 sec overload) (at 400 V) [A]	233	286	347	435	528
	Continuous (at 460 V) [A]	190	240	302	361	443
	Intermittent (60 sec overload) (at 460 V) [A]	209	264	332	397	487
	Continuous KVA (at 400 V) [KVA]	147	180	218	274	333
	Continuous KVA (at 460 V) [KVA]	151	191	241	288	353
Max. input current						
 130BA229.10	Continuous (at 400 V) [A]	204	251	304	381	463
	Continuous (at 460 V) [A]	183	231	291	348	427
	Max. cable size, mains motor and load share [mm ² (AWG ²)]	2 x 70 (2 x 2/0)	2 x 70 (2 x 2/0)	2 x 185 (2 x 350 mcm)	2 x 185 (2 x 350 mcm)	2 x 185 (2 x 350 mcm)
	Max. external pre-fuses [A] ¹	300	350	400	500	600
	Estimated power loss at rated max. load [W] ⁴⁾	3234	3782	4213	5119	5893
	Weight, Unit Size IP21, IP 54 [kg]	96	104	125	136	151
	Weight, Unit Size IP00 [kg]	82	91	112	123	138
	Efficiency ⁴⁾	0.98				
	Output frequency	0 - 800 Hz				
	Heatsink overtemp. trip	85 °C	90 °C	105 °C	105 °C	115 °C
	Power card ambient trip	60 °C				

7



General Specifications

AF-600 FP High Power Operating Instructions

Mains Supply 3 x 380 - 480 VAC

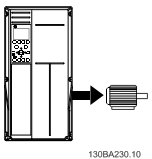
	Typical Shaft output at 400 V [kW]	315	355	400	450
	Typical Shaft output at 460 V [HP]	450	500	600	600
	Unit Size IP21	51	51	51	51
	Unit Size IP54	51	51	51	51
	Unit Size IP00	52	52	52	52
Output current					
 130BA230.10	Continuous (at 400 V) [A]	600	658	745	800
	Intermittent (60 sec overload) (at 400 V) [A]	660	724	820	880
	Continuous (at 460 V) [A]	540	590	678	730
	Intermittent (60 sec overload) (at 460 V) [A]	594	649	746	803
	Continuous KVA (at 400 V) [KVA]	416	456	516	554
	Continuous KVA (at 460 V) [KVA]	430	470	540	582

Max. input current

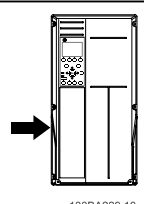
 130BA229.10	Continuous (at 400 V) [A]	590	647	733	787
	Continuous (at 460 V) [A]	531	580	667	718
	Max. cable size, mains, motor and load share [mm ² (AWG ²)]	4x240 (4x500 mcm)	4x240 (4x500 mcm)	4x240 (4x500 mcm)	4x240 (4x500 mcm)
	Max. external pre-fuses [A] ¹	700	900	900	900
	Estimated power loss at rated max. load [W] ⁴	7630	7701	8879	9428
	Weight, Unit Size IP21, IP 54 [kg]	263	270	272	313
	Weight, Unit Size IP00 [kg]	221	234	236	277
	Efficiency ⁴	0.98			
	Output frequency	0 - 600 Hz			
	Heatsink overtemp. trip	95 °C			
	Power card ambient trip	68 °C			

7



General Specifications

AF-600 FP High Power Operating Instructions

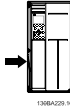
Mains Supply 3 x 380 - 480 VAC								
	Typical Shaft output at 400 V [kW]	500	560	630	710	800	1000	
	Typical Shaft output at 460 V [HP]	650	750	900	1000	1200	1350	
	Unit Size IP21, 54 without/ with options cabinet	61/63	61/63	61/63	61/63	62/64	62/64	
	Output current							
	Continuous (at 400 V) [A]	880	990	1120	1260	1460	1720	
	Intermittent (60 sec overload) (at 400 V) [A]	968	1089	1232	1386	1606	1892	
	Continuous (at 460 V) [A]	780	890	1050	1160	1380	1530	
	Intermittent (60 sec overload) (at 460 V) [A]	858	979	1155	1276	1518	1683	
	Continuous KVA (at 400 V) [KVA]	610	686	776	873	1012	1192	
	Continuous KVA (at 460 V) [KVA]	621	709	837	924	1100	1219	
Max. input current								
	Continuous (at 400 V) [A]	857	964	1090	1227	1422	1675	
	Continuous (at 460 V) [A]	759	867	1022	1129	1344	1490	
	Max. cable size, motor [mm ² (AWG ²)]	8x150 (8x300 mcm)				12x150 (12x300 mcm)		
	Max. cable size, mains [mm ² (AWG ²)]	8x240 (8x500 mcm)						
	Max. cable size, loadsharing [mm ² (AWG ²)]	4x120 (4x250 mcm)						
	Max. external pre-fuses [A] ¹	1600		2000		2500		
	Estimated power loss at rated max. load [W] ⁴⁾							
	Weight, enclosure IP21, IP 54 [kg]	1004/ 1299	1004/ 1299	1004/ 1299	1004/ 1299	1246/ 1541	1246/ 1541	
	Weight Rectifier Module [kg]	102	102	102	102	136	136	
	Weight Inverter Module [kg]	102	102	102	136	102	102	
	Efficiency ⁴⁾	0.98						
	Output frequency	0-600 Hz						
	Heatsink overtemp. trip	95 °C						
	Power card ambient trip	68 °C						

7



General Specifications

AF-600 FP High Power Operating Instructions

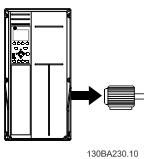
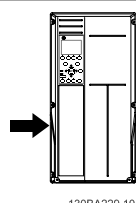
Mains Supply 3 x 525 - 690 VAC					
	Typical Shaft output at 550 V [kW]	110	132	160	200
	Typical Shaft output at 575 V [HP]	150	200	250	300
	Unit Size IP21	41	41	42	42
	Unit Size IP54	41	41	42	42
	Unit Size IP00	43	43	44	44
	Output current				
 130BA230.10	Continuous (at 550 V) [A]	162	201	253	303
	Intermittent (60 sec overload) (at 550 V) [A]	178	221	278	333
	Continuous (at 575/690 V) [A]	155	192	242	290
	Intermittent (60 sec overload) (at 575/690 V) [A]	171	211	266	319
	Continuous KVA (at 550 V) [KVA]	154	191	241	289
	Continuous KVA (at 575 V) [KVA]	154	191	241	289
	Continuous KVA (at 690 V) [KVA]	185	229	289	347
Max. input current					
 130BA229.10	Continuous (at 550 V) [A]	158	198	245	299
	Continuous (at 575 V) [A]	151	189	234	286
	Continuous (at 690 V) [A]	155	197	240	296
	Max. cable size, mains motor, load share and brake [mm ² (AWG)]	2 x 70 (2 x 2/0)	2 x 70 (2 x 2/0)	2 x 185 (2 x 350 mcm)	2 x 185 (2 x 350 mcm)
	Max. external pre-fuses [A] ¹	315	350	350	400
	Estimated power loss at rated max. load [W] ⁴⁾	3114	3612	4292	5156
	Weight, Unit Size IP21, IP 54 [kg]	96	104	125	136
	Weight, Unit Size IP00 [kg]	82	91	112	123
	Efficiency ⁴⁾	0.98			
	Output frequency	0 - 600 Hz			
	Heatsink overtemp. trip	85 °C	90 °C	110 °C	110 °C
	Power card ambient trip	60 °C			

7



General Specifications

AF-600 FP High Power Operating Instructions

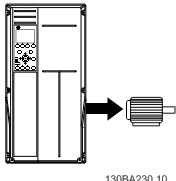
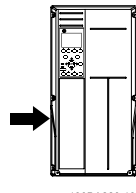
Mains Supply 3 x 525 - 690 VAC				
	Typical Shaft output at 550 V [kW]	250	315	355
	Typical Shaft output at 575 V [HP]	350	400	450
	Unit Size IP21	42	42	51
	Unit Size IP54	42	42	51
	Unit Size IP00	44	44	52
	Output current			
 130BA230.10	Continuous (at 550 V) [A]	360	418	470
	Intermittent (60 sec overload) (at 550 V) [A]	396	460	517
	Continuous (at 575/690 V) [A]	344	400	450
	Intermittent (60 sec overload) (at 575/690 V) [A]	378	440	495
	Continuous KVA (at 550 V) [KVA]	343	398	448
	Continuous KVA (at 575 V) [KVA]	343	398	448
	Continuous KVA (at 690 V) [KVA]	411	478	538
Max. input current				
 130BA229.10	Continuous (at 550 V) [A]	355	408	453
	Continuous (at 575 V) [A]	339	390	434
	Continuous (at 690 V) [A]	352	400	434
	Max. cable size, mains, motor and load share [mm ² (AWG)]	2 x 185 (2 x 350 mcm)	2 x 185 (2 x 350 mcm)	4 x 240 (4 x 500 mcm)
	Max. external pre-fuses [A] ¹	500	550	700
	Estimated power loss at rated max. load [W] ⁴⁾	5821	6149	6449
	Weight, Unit Size IP21, IP 54 [kg]	151	165	263
	Weight, Unit Size IP00 [kg]	138	151	221
	Efficiency ⁴⁾		0.98	
	Output frequency	0 - 600 Hz	0 - 500 Hz	0 - 500 Hz
	Heatsink overtemp. trip	110 °C	110 °C	85 °C
	Power card ambient trip	60 °C	60 °C	68 °C



General Specifications

AF-600 FP High Power Operating Instructions

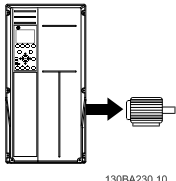
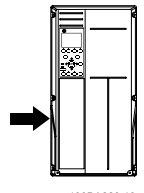
Mains Supply 3 x 525 - 690 VAC				
	Typical Shaft output at 550 V [kW]	400	450	500
	Typical Shaft output at 575 V [HP]	500	600	650
	Enclosure IP21	51	51	51
	Enclosure IP54	51	51	51
	Enclosure IP00	52	52	52
	Output current			
 <p>130BA230.10</p>	Continuous (at 550 V) [A]	523	596	630
	Intermittent (60 sec overload) (at 550 V) [A]	575	656	693
	Continuous (at 575/690 V) [A]	500	570	630
	Intermittent (60 sec overload) (at 575/690 V) [A]	550	627	693
	Continuous KVA (at 550 V) [KVA]	498	568	600
	Continuous KVA (at 575 V) [KVA]	498	568	627
	Continuous KVA (at 690 V) [KVA]	598	681	753
Max. input current				
 <p>130BA229.10</p>	Continuous (at 550 V) [A]	504	574	607
	Continuous (at 575 V) [A]	482	549	607
	Continuous (at 690 V) [A]	482	549	607
	Max. cable size, mains, motor and load share [mm ² (AWG)]	4x240 (4x500 mcm)	4x240 (4x500 mcm)	4x240 (4x500 mcm)
	Max. external pre-fuses [A] ¹	700	900	900
	Estimated power loss at rated max. load [W] ⁴⁾	7249	8727	9673
	Weight, enclosure IP21, IP 54 [kg]	263	272	313
	Weight, enclosure IP00 [kg]	221	236	277
	Efficiency ⁴⁾	0.98		
	Output frequency	0 - 500 Hz		
	Heatsink overtemp. trip	85 °C		
	Power card ambient trip	68 °C		



General Specifications

AF-600 FP High Power Operating Instructions

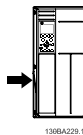
Mains Supply 3 x 525 - 690 VAC						
	Typical Shaft output at 550 V [kW]	560	670	750	850	1000
	Typical Shaft output at 575 V [HP]	750	950	1050	1150	1350
	Unit Size IP21, 54 without/with options cabinet	61/ 63	61/ 63	61/ 63	62/ 64	62/ 64
	Output current					
	Continuous (at 550 V) [A]	763	889	988	1108	1317
	Intermittent (60 sec overload) (at 550 V) [A]	839	978	1087	1219	1449
	Continuous (at 575/690 V) [A]	730	850	945	1060	1260
	Intermittent (60 sec overload) (at 575/690 V) [A]	803	935	1040	1166	1386
	Continuous KVA (at 550 V) [KVA]	727	847	941	1056	1255
	Continuous KVA (at 575 V) [KVA]	727	847	941	1056	1255
	Continuous KVA (at 690 V) [KVA]	872	1016	1129	1267	1506
Max. input current						
	Continuous (at 550 V) [A]	743	866	962	1079	1282
	Continuous (at 575 V) [A]	711	828	920	1032	1227
	Continuous (at 690 V) [A]	711	828	920	1032	1227
	Max. cable size,motor [mm ² (AWG ²)]	8x150 (8x300 mcm)			12x150 (12x300 mcm)	
	Max. cable size,mains [mm ² (AWG ²)]	8x240 (8x500 mcm)				
	Max. cable size, loadsharing [mm ² (AWG ²)]	4x120 (4x250 mcm)				
	Max. external pre-fuses [A] ₁	1600				2000
	Estimated power loss at rated max. load [W] ⁴⁾					
	Weight, Unit Size IP21, IP 54 [kg]	1004/ 1299	1004/ 1299	1004/ 1299	1246/ 1541	1246/ 1541
	Weight, Rectifier Module [kg]	102	102	102	136	136
	Weight, Inverter Module [kg]	102	102	136	102	102
	Efficiency ⁴⁾	0.98				
	Output frequency	0-500 Hz				
	Heatsink overtemp. trip	85 °C				
	Power card ambient trip	68 °C				

1) For type of fuse see section *Fuses*.

2) American Wire Gauge.



- 3) Measured using 5 m screened motor cables at rated load and rated frequency.
- 4) The typical power loss is at nominal load conditions and expected to be within +/-15% (tolerance relates to variety in voltage and cable conditions). Values are based on a typical motor efficiency (eff2/eff3 border line). Motors with lower efficiency will also add to the power loss in the drive and opposite. If the switching frequency is increased from the default setting, the power losses may rise significantly. keypad and typical control card power consumptions are included. Further options and customer load may add up to 30W to the losses. (Though typical only 4W extra for a fully loaded control card, or options for slot A or slot B, each). Although measurements are made with state of the art equipment, some measurement inaccuracy must be allowed for (+/-5%).



8 Warnings and Alarms

A warning or an alarm is signalled by the relevant LED on the front of the frequency converter and indicated by a code on the display.

A warning remains active until its cause is no longer present. Under certain circumstances operation of the motor may still be continued. Warning messages may be critical, but are not necessarily so.

In the event of an alarm, the frequency converter will have tripped. Alarms must be reset to restart operation once their cause has been rectified.

This may be done in four ways:

1. By using the [RESET] control button on the keypad.
2. Via a digital input with the "Reset" function.
3. Via serial communication/optional network.
4. By resetting automatically using the [Auto Reset] function, which is a default setting for AF-600 FP Drive, see *H-04 Auto-Reset (Times)* in the **AF-600 FP Programming Guide**

NOTE

After a manual reset using the [RESET] button on the keypad, the [AUTO] or [HAND] button must be pressed to restart the motor.

If an alarm cannot be reset, the reason may be that its cause has not been rectified, or the alarm is trip-locked (see also *Table 8.1*).

CAUTION

Alarms that are trip-locked offer additional protection, means that the mains supply must be switched off before the alarm can be reset. After being switched back on, the frequency converter is no longer blocked and may be reset as described above once the cause has been rectified.

Alarms that are not trip-locked can also be reset using the automatic reset function in *H-04 Auto-Reset (Times)* (Warning: automatic wake-up is possible!)

If a warning and alarm is marked against a code in the table on the following page, this means that either a warning occurs before an alarm, or it can be specified whether it is a warning or an alarm that is to be displayed for a given fault.

This is possible, for instance, in *F-10 Electronic Overload*. After an alarm or trip, the motor carries on coasting, and the alarm and warning flash on the frequency converter. Once the problem has been rectified, only the alarm continues flashing.

Warnings and Alarms
AF-600 FP High Power Operating Instructions

No.	Description	Warning	Alarm/Trip	Alarm/Trip Lock	Parameter Reference
1	10 Volts low	X			
2	Live zero error	(X)	(X)		AN-01
4	Mains phase loss	(X)	(X)	(X)	SP-12
5	DC link voltage high	X			
6	DC link voltage low	X			
7	DC over voltage	X	X		
8	DC under voltage	X	X		
9	Inverter overloaded	X	X		
10	Motor Elec. OL over temperature	(X)	(X)		F-10
11	Motor thermistor over temperature	(X)	(X)		F-10
12	Torque limit	X	X		
13	Over Current	X	X	X	
14	Earth fault	X	X	X	
15	Hardware mismatch		X	X	
16	Short Circuit		X	X	
17	Control word timeout	(X)	(X)		O-04
18	Start failed		X		
23	Internal Fan Fault	X			
24	External Fan Fault	X			SP-53
29	Drive over temperature	X	X	X	
30	Motor phase U missing	(X)	(X)	(X)	H-78
31	Motor phase V missing	(X)	(X)	(X)	H-78
32	Motor phase W missing	(X)	(X)	(X)	H-78
33	Inrush fault		X	X	
34	Network communication fault	X	X		
36	Mains failure	X	X		
38	Internal fault		X	X	
39	Heatsink sensor		X	X	
40	Overload of Digital Output Terminal 27	(X)			E-00, E-51
41	Overload of Digital Output Terminal 29	(X)			E-00, E-51
42	Overload of Digital Output On X30/6 (OPCGPIO)	(X)			E-56
42	Overload of Digital Output On X30/7 (OPCGPIO)	(X)			E-57
46	Pwr. card supply		X	X	
47	24 V supply low	X	X	X	
48	1.8 V supply low		X	X	
49	Speed limit	X			H-36
50	Auto Tune calibration failed		X		
51	Auto Tune check U_{nom} and I_{nom}		X		
52	Auto Tune low I_{nom}		X		
53	Auto Tune motor too big		X		
54	Auto Tune motor too small		X		
55	Auto Tune parameter out of range		X		
56	Auto Tune interrupted by user		X		
57	Auto Tune timeout		X		
58	Auto Tune internal fault	X	X		
59	Current limit	X			
60	External interlock				
62	Output Frequency at Maximum Limit	X			
64	Voltage Limit	X			
65	Control Board Over-temperature	X	X	X	
66	Heat sink Temperature Low	X			
67	Option Configuration has Changed		X		
69	Pwr. Card Temp		X	X	



Warnings and Alarms

AF-600 FP High Power Operating Instructions

No.	Description	Warning	Alarm/Trip	Alarm/Trip Lock	Parameter Reference
70	Illegal Drive configuration			X	
76	Power Unit Setup	X			
77	Reduced power mode	X			
79	Illegal PS config		X	X	
80	Drive Restored to Factory Settings		X		
91	Analog input 54 wrong settings			X	
92	NoFlow	X	X		AP-2#
93	Dry Pump	X	X		AP-2#
94	End of Curve	X	X		AP-5#
95	Broken Belt	X	X		AP-6#
96	Start Delayed	X			AP-7#
97	Stop Delayed	X			AP-7#
98	Clock Fault	X			K-7#
201	Fire M was Active				
202	Fire M Limits Exceeded				
203	Missing Motor				
204	Locked Rotor				
243	Brake IGBT	X	X		
244	Heatsink temp	X	X	X	
245	Heatsink sensor		X	X	
246	Pwr.card supply		X	X	
247	Pwr.card temp		X	X	
248	Illegal PS config		X	X	
250	New spare parts			X	
251	New Type Code		X	X	

Table 8.1 Alarm/Warning code list

(X) Dependent on parameter

1) Can not be Auto reset via *H-04 Auto-Reset (Times)*

A trip is the action when an alarm has appeared. The trip will coast the motor and can be reset by pressing the reset button or make a reset by a digital input (parameter group E-1# [1]). The original event that caused an alarm cannot damage the frequency converter or cause dangerous conditions. A trip lock is an action when an alarm occurs, which may cause damage to frequency converter or

connected parts. A Trip Lock situation can only be reset by a power cycling.

LED indication	
Warning	yellow
Alarm	flashing red
Trip locked	yellow and red

Table 8.2 LED Indication



Alarm Word and Extended Status Word					
Bit	Hex	Dec	Alarm Word	Warning Word	Extended Status Word
0	00000001	1			Ramping
1	00000002	2	Pwr. Card Temp	Pwr. Card Temp	Auto Tune Running
2	00000004	4	Earth Fault	Earth Fault	Start CW/CCW
3	00000008	8	Ctrl.Card Temp	Ctrl.Card Temp	Slow Down
4	00000010	16	Ctrl. Word TO	Ctrl. Word TO	Catch Up
5	00000020	32	Over Current	Over Current	Feedback High
6	00000040	64	Torque Limit	Torque Limit	Feedback Low
7	00000080	128	Motor Th Over	Motor Th Over	Output Current High
8	00000100	256	Motor Elec. OL Over	Motor Elec. OL Over	Output Current Low
9	00000200	512	Inverter Overld.	Inverter Overld.	Output Freq High
10	00000400	1024	DC under Volt	DC under Volt	Output Freq Low
11	00000800	2048	DC over Volt	DC over Volt	
12	00001000	4096	Short Circuit	DC Voltage Low	
13	00002000	8192	Inrush Fault	DC Voltage High	
14	00004000	16384	Mains ph. Loss	Mains ph. Loss	Out of Speed Range
15	00008000	32768	Auto Tune Not OK	No Motor	OVC Active
16	00010000	65536	Live Zero Error	Live Zero Error	
17	00020000	131072	Internal Fault	10V Low	
18	00040000	262144			
19	00080000	524288	U phase Loss		
20	00100000	1048576	V phase Loss		
21	00200000	2097152	W phase Loss	Speed Limit	
22	00400000	4194304	Network Fault	Network Fault	
23	00800000	8388608	24V Supply Low	24V Supply Low	
24	01000000	16777216	Mains Failure	Mains Failure	
25	02000000	33554432	1.8V Supply Low	Current Limit	
26	04000000	67108864		Low Temp	
27	08000000	134217728		Voltage Limit	
28	10000000	268435456	Option Change	Unused	
29	20000000	536870912	Drive Restored to Factory Settings	Unused	
30	40000000	1073741824		Unused	

Table 8.3 Description of Alarm Word, Warning Word and Extended Status Word

The alarm words, warning words and extended status words can be read out via serial bus or optional network for diagnosis. See also *DR-90 Alarm Word*, *DR-92 Warning Word* and *DR-94 Ext. Status Word*.



8.1.1 Fault Messages

WARNING 1, 10 volts low

The control card voltage is below 10 V from terminal 50. Remove some of the load from terminal 50, as the 10 V supply is overloaded. Max. 15 mA or minimum 590 Ω .

This condition can be caused by a short in a connected potentiometer or improper wiring of the potentiometer.

Troubleshooting: Remove the wiring from terminal 50. If the warning clears, the problem is with the customer wiring. If the warning does not clear, replace the control card.

WARNING/ALARM 2, Live zero error

This warning or alarm will only appear if programmed by the user in *AN-01 Live Zero Timeout Function*. The signal on one of the analog inputs is less than 50% of the minimum value programmed for that input. This condition can be caused by broken wiring or faulty device sending the signal.

WARNING/ALARM 4, Mains phase loss A phase is missing on the supply side, or the mains voltage imbalance is too high. This message also appears for a fault in the input rectifier on the frequency converter. Options are programmed at *SP-12 Function at Line Imbalance*.

Troubleshooting: Check the supply voltage and supply currents to the frequency converter.

WARNING 5, DC link voltage high

The intermediate circuit voltage (DC) is higher than the high voltage warning limit. The limit is dependent on the drive voltage rating. The frequency converter is still active.

WARNING 6, DC link voltage low

The intermediate circuit voltage (DC) is lower than the low voltage warning limit. The limit is dependent on the drive voltage rating. The frequency converter is still active.

WARNING/ALARM 7, DC overvoltage

If the intermediate circuit voltage exceeds the limit, the frequency converter trips after a time.

Troubleshooting:

- Extend the ramp time
- Change the ramp type
- Activate functions in *B-10 Brake Function*
- Increase *SP-26 Trip Delay at Drive Fault*

WARNING/ALARM 8, DC under voltage

If the intermediate circuit voltage (DC) drops below the under voltage limit, the frequency converter checks if a 24V backup supply is connected. If no 24V backup supply is connected, the frequency converter trips after a fixed time delay. The time delay varies with unit size.

WARNING/ALARM 9, Inverter overloaded

The frequency converter is about to cut out because of an overload (too high current for too long). The counter for electronic, thermal inverter protection gives a warning at 98% and trips at 100%, while giving an alarm. The frequency converter *cannot* be reset until the counter is below 90%.

The fault is that the frequency converter is overloaded by more than 100% for too long. NOTE: See the derating section in the Design Guide for more details if a high switching frequency is required.

WARNING/ALARM 10, Motor overload temperature

According to the electronic thermal protection, the motor is too hot. Select whether the frequency converter gives a warning or an alarm when the counter reaches 100% in *F-10 Electronic Overload*. The fault is that the motor is overloaded by more than 100% for too long.

Troubleshooting:

Check if motor is over heating.

If the motor is mechanically overloaded

That the motor *P-03 Motor Current* is set correctly.

Motor data in parameters P-02, P-03, P-06, P-07, F-04 and F-05 are set correctly.

The setting in *F-11 Motor External Fan*.

Run Auto tune in *P-04 Auto Tune*.

WARNING/ALARM 11, Motor thermistor over temp

The thermistor or the thermistor connection is disconnected. Select whether the frequency converter gives a warning or an alarm when the counter reaches 100% in *F-10 Electronic Overload*.

Troubleshooting:

Check if motor is over heating.

Check if the motor is mechanically overloaded.

Check that the thermistor is connected correctly between terminal 53 or 54 (analog voltage input) and terminal 50 (+10 V supply), or between terminal 18 or 19 (digital input PNP only) and terminal 50.

If using a thermal switch or thermistor, check the programming of *F-12 Motor Thermistor Input* matches sensor wiring.

WARNING/ALARM 12, Torque limit

The torque is higher than the value in *F-40 Torque Limiter (Driving)* or the torque is higher than the value in *F-41 Torque Limiter (Braking)*. *SP-25 Trip Delay at Torque Limit* can be used to change this from a warning only condition to a warning followed by an alarm.

**WARNING/ALARM 13, Over current**

The inverter peak current limit (approx. 200% of the rated current) is exceeded. The warning lasts about 1.5 sec., then the frequency converter trips and issues an alarm. If extended mechanical brake control is selected, trip can be reset externally.

Troubleshooting:

This fault may be caused by shock loading or fast acceleration with high inertia loads.

Turn off the frequency converter. Check if the motor shaft can be turned.

Check that the motor size matches the frequency converter.

Incorrect motor data in parameters P-02, P-03, P-06, P-07, F-04 and F-05.

ALARM 14, Earth (ground) fault

There is a discharge from the output phases to earth, either in the cable between the frequency converter and the motor or in the motor itself.

Troubleshooting:

Turn off the frequency converter and remove the earth fault.

Measure the resistance to ground of the motor leads and the motor with a megohmmeter to check for earth faults in the motor.

Perform current sensor test.

ALARM 15, Hardware mismatch

A fitted option is not operational with the present control board hardware or software.

Record the value of the following parameters and contact your GE supplier:

ID-40 Drive Type

ID-41 Power Section

ID-42 Voltage

ID-43 Software Version

ID-45 Actual Typecode String

ID-49 SW ID Control Card

ID-50 SW ID Power Card

ID-60 Option Mounted

ID-61 Option SW Version

ALARM 16, Short circuit

There is short-circuiting in the motor or on the motor terminals.

Turn off the frequency converter and remove the short-circuit.

WARNING/ALARM 17, Control word timeout

There is no communication to the frequency converter. The warning will only be active when *O-04 Control Word Timeout Function* is NOT set to OFF.

If *O-04 Control Word Timeout Function* is set to *Stop and Trip*, a warning appears and the frequency converter decels until it trips, while giving an alarm.

Troubleshooting:

Check connections on the serial communication cable.

Increase *O-03 Control Word Timeout Time*

Check operation of the communication equipment.

Verify proper installation based on EMC requirements.

ALARM 18, Start failed

The speed has not been able to exceed *AP-70 Compressor Start Max Speed [RPM]* during start within the allowed time. (set in *AP-72 Compressor Start Max Time to Trip*). This may be caused by a blocked motor.

WARNING 23, Internal fan fault

The fan warning function is an extra protection function that checks if the fan is running / mounted. The fan warning can be disabled in *SP-53 Fan Monitor* ([0] Disabled).

For the 4x, 5x, and 6x unit size drives, the regulated voltage to the fans is monitored.

Troubleshooting:

Check fan resistance.

Check soft charge fuses.

WARNING 24, External fan fault

The fan warning function is an extra protection function that checks if the fan is running / mounted. The fan warning can be disabled in *SP-53 Fan Monitor* ([0] Disabled).

For the 4x, 5x, and 6x unit size drives, the regulated voltage to the fans is monitored.

Troubleshooting:

Check fan resistance.

Check soft charge fuses.

ALARM 29, Heatsink temp

The maximum temperature of the heatsink has been exceeded. The temperature fault will not be reset until the temperature falls below a defined heatsink temperature. The trip and reset point are different based on the drive power size.



Troubleshooting:

- Ambient temperature too high.
- Too long motor cable.
- Incorrect clearance above and below the drive.
- Dirty heatsink.
- Blocked air flow around the drive.
- Damaged heatsink fan.

For the 4x, 5x, and 6x unit size Drives, this alarm is based on the temperature measured by the heatsink sensor mounted inside the IGBT modules. For the 6x unit size drives, this alarm can also be caused by the thermal sensor in the Rectifier module.

Troubleshooting:

- Check fan resistance.
- Check soft charge fuses.
- IGBT thermal sensor.

ALARM 30, Motor phase U missing

Motor phase U between the frequency converter and the motor is missing.

Turn off the frequency converter and check motor phase U.

ALARM 31, Motor phase V missing

Motor phase V between the frequency converter and the motor is missing.

Turn off the frequency converter and check motor phase V.

ALARM 32, Motor phase W missing

Motor phase W between the frequency converter and the motor is missing.

Turn off the frequency converter and check motor phase W.

ALARM 33, Inrush fault

Too many power-ups have occurred within a short time period. Let unit cool to operating temperature.

WARNING/ALARM 34, Network communication fault

The network on the communication option card is not working.

WARNING/ALARM 35, Out of frequency range:

This warning is active if the output frequency has reached the high limit (set in par. H-73) or low limit (set in par. H-72).

WARNING/ALARM 36, Mains failure

This warning/alarm is only active if the supply voltage to the frequency converter is lost and *SP-10 Line failure* is NOT set to OFF. Check the fuses to the frequency converter

ALARM 38, Internal fault

It may be necessary to contact your GE supplier. Some typical alarm messages:

0	Serial port cannot be initialized. Serious hardware failure
256-258	Power EEPROM data is defect or too old
512	Control board EEPROM data is defect or too old
513	Communication time out reading EEPROM data
514	Communication time out reading EEPROM data
515	Application Orientated Control cannot recognize the EEPROM data
516	Cannot write to the EEPROM because a write command is on progress
517	Write command is under time out
518	Failure in the EEPROM
519	Missing or invalid Barcode data in EEPROM
783	Parameter value outside of min/max limits
1024-1279	A can-telegram that has to be sent, couldn't be sent
1281	Digital Signal Processor flash timeout
1282	Power micro software version mismatch
1283	Power EEPROM data version mismatch
1284	Cannot read Digital Signal Processor software version
1299	Option SW in slot A is too old
1300	Option SW in slot B is too old
1302	Option SW in slot C1 is too old
1315	Option SW in slot A is not supported (not allowed)
1316	Option SW in slot B is not supported (not allowed)
1318	Option SW in slot C1 is not supported (not allowed)
1379	Option A did not respond when calculating Platform Version.
1380	Option B did not respond when calculating Platform Version.
1536	An exception in the Application Orientated Control is registered. Debug information written in keypad
1792	DSP watchdog is active. Debugging of power part data Motor Orientated Control data not transferred correctly
2049	Power data restarted
2064-2072	H081x: option in slot x has restarted
2080-2088	H082x: option in slot x has issued a powerup-wait
2096-2104	H083x: option in slot x has issued a legal powerup-wait
2304	Could not read any data from power EEPROM
2305	Missing SW version from power unit
2314	Missing power unit data from power unit
2315	Missing SW version from power unit
2316	Missing io_statepage from power unit
2324	Power card configuration is determined to be incorrect at power up
2330	Power size information between the power cards does not match



2561	No communication from DSP to ATACD
2562	No communication from ATACD to DSP (state running)
2816	Stack overflow Control board module
2817	Scheduler slow tasks
2818	Fast tasks
2819	Parameter thread
2820	keypad Stack overflow
2821	Serial port overflow
2822	USB port overflow
2836	cfListMemPool to small
3072-51 22	Parameter value is outside its limits
5123	Option in slot A: Hardware incompatible with Control board hardware
5124	Option in slot B: Hardware incompatible with Control board hardware
5125	Option in slot C0: Hardware incompatible with Control board hardware
5126	Option in slot C1: Hardware incompatible with Control board hardware
5376-62 31	Out of memory

8

ALARM 39, Heatsink sensor

No feedback from the heatsink temperature sensor.

The signal from the IGBT thermal sensor is not available on the power card. The problem could be on the power card, on the gate drive card, or the ribbon cable between the power card and gate drive card.

WARNING 40, Overload of Digital Output Terminal 27

Check the load connected to terminal 27 or remove short-circuit connection. Check *E-00 Digital I/O Mode* and *E-51 Terminal 27 Mode*.

WARNING 41, Overload of Digital Output Terminal 29

Check the load connected to terminal 29 or remove short-circuit connection. Check *E-00 Digital I/O Mode* and *E-52 Terminal 29 Mode*.

WARNING 42, Overload of Digital Output on X30/6 or Overload of Digital Output on X30/7

For X30/6, check the load connected to X30/6 or remove short-circuit connection. Check *E-56 X30/6 Digital Out (OPCGPIO)*.

For X30/7, check the load connected to X30/7 or remove short-circuit connection. Check *E-57 Term X30/7 Digital Out (OPCGPIO)*.

ALARM 46, Power card supply

The supply on the power card is out of range.

There are three power supplies generated by the switch mode power supply (SMPS) on the power card: 24V, 5V, +/- 18V. When powered with 24V DC with the OPC24VPS option, only the 24V and 5V supplies are monitored. When powered with three phase mains voltage, all three supplied are monitored.

WARNING 47, 24 V supply low

The 24V DC is measured on the control card. The external 24V DC backup power supply may be overloaded, otherwise contact your GE supplier.

WARNING 48, 1.8 V supply low

The 1.8V DC supply used on the control card is outside of allowable limits. The power supply is measured on the control card.

WARNING 49, Speed limit

When the speed is not within the specified range in par. F-18 and par. F-17. the drive will show a warning. When the speed is below the specified limit in *H-36 Trip Speed Low [RPM]* (except when starting or stopping) the drive will trip.

ALARM 50, Auto tune calibration failed

Contact your GE supplier.

ALARM 51, Auto tune check Unom and Inom

The setting of motor voltage, motor current, and motor power is presumably wrong. Check the settings.

ALARM 52, Auto tune low Inom

The motor current is too low. Check the settings.

ALARM 53, Auto tune motor too big

The motor is too big for the Auto tune to be carried out.

ALARM 54, Auto tune motor too small

The motor is too small for the Auto tune to be carried out.

ALARM 55, Auto tune Parameter out of range

The parameter values found from the motor are outside acceptable range.

ALARM 56, Auto tune interrupted by user

The Auto tune has been interrupted by the user.

ALARM 57, Auto tune timeout

Try to start the Auto tune again a number of times, until the Auto tune is carried out. Please note that repeated runs may heat the motor to a level where the resistance R_s and R_r are increased. In most cases, however, this is not critical.

ALARM 58, Auto tune internal fault

Contact your GE supplier.

WARNING 59, Current limit

The current is higher than the value in *F-43 Current Limit*.

WARNING 60, External interlock

External interlock has been activated. To resume normal operation, apply 24 V DC to the terminal programmed for external interlock and reset the frequency converter (via serial communication, digital I/O, or by pressing reset button on keypad).

WARNING 62, Output frequency at maximum limit

The output frequency is higher than the value set in *F-03 Max Output Frequency 1*

WARNING 64, Voltage limit

The load and speed combination demands a motor voltage higher than the actual DC link voltage.

**WARNING/ALARM/TRIP 65, Control card over temperature**

Control card over temperature: The cutout temperature of the control card is 80° C.

WARNING 66, Heatsink temperature low

This warning is based on the temperature sensor in the IGBT module.

Troubleshooting:**ALARM 67, Option module configuration has changed**

One or more options have either been added or removed since the last power-down.

ALARM 69, Power card temperature

The temperature sensor on the power card is either too hot or too cold.

Troubleshooting:

Check the operation of the door fans.

Check that the filters for the door fans are not blocked.

Check that the gland plate is properly installed on IP 21 and IP 54 (NEMA 1 and NEMA 12) drives.

ALARM 70, Illegal Drive Configuration

Actual combination of control board and power board is illegal.

WARNING 76, Power Unit Setup

The required number of power units does not match the detected number of active power units.

WARNING 77, Reduced power mode:

This warning indicates that the drive is operating in reduced power mode (i.e. less than the allowed number of inverter sections). This warning will be generated on power cycle when the drive is set to run with fewer inverters and will remain on.

ALARM 79, Illegal power section configuration

The scaling card is the incorrect part number or not installed. Also MK102 connector on the power card could not be installed.

ALARM 80, Drive Restored to Factory Settings

Parameter settings are restored to factory settings after a manual reset.

ALARM 92, No flow

A no-load situation has been detected in the system. See parameter group AP-2#.

ALARM 93, Dry pump

A no-flow situation and high speed indicates that the pump has run dry. See parameter group AP-2#.

ALARM 94, End of curve

Feedback stays lower than the set point which may indicate leakage in the pipe system. See parameter group AP-5#.

ALARM 95, Broken belt

Torque is below the torque level set for no load, indicating a broken belt. See parameter group AP-6#.

ALARM 96, Start delayed

Motor start has been delayed due to short-cycle protection active. See parameter group AP-7#.

WARNING 97, Stop delayed

Stopping the motor has been delayed due to short cycle protection is active. See parameter group AP-7#.

WARNING 98, Clock fault

Clock Fault. Time is not set or RTC clock (if mounted) has failed. See parameter group K-7#.

WARNING 201, Fire Mode was Active

Fire Mode has been active.

WARNING 202, Fire Mode Limits Exceeded

Fire Mode has suppressed one or more warranty voiding alarms.

WARNING 203, Missing Motor

A multi-motor under-load situation was detected, this could be due to e.g. a missing motor.

WARNING 204, Locked Rotor

A multi-motor overload situation was detected, this could be due to e.g. a locked rotor.

ALARM 244, Heatsink temperature

This alarm is only for 6x unit size drives. It is equivalent to Alarm 29. The report value in the alarm log indicates which power module generated the alarm:

- 1 = left most inverter module.
- 2 = middle inverter module in 62 or 64 drive.
- 2 = right inverter module in 61 or 63 drive.
- 3 = right inverter module in 62 or 64 drive.
- 5 = rectifier module.

ALARM 245, Heatsink sensor

This alarm is only for 6x unit size drives. It is equivalent to Alarm 39. The report value in the alarm log indicates which power module generated the alarm:

- 1 = left most inverter module.
- 2 = middle inverter module in 62 or 64 drive.
- 2 = right inverter module in 61 or 63 drive.
- 3 = right inverter module in 62 or 64 drive.
- 5 = rectifier module.

ALARM 246, Power card supply

This alarm is only for 6x unit size drives. It is equivalent to Alarm 46. The report value in the alarm log indicates which power module generated the alarm:

- 1 = left most inverter module.
- 2 = middle inverter module in 62 or 64 drive.
- 2 = right inverter module in 61 or 63 drive.
- 3 = right inverter module in 62 or 64 drive.
- 5 = rectifier module.

**ALARM 247, Power card temperature**

This alarm is only for 6x unit size drives. It is equivalent to Alarm 69. The report value in the alarm log indicates which power module generated the alarm:

- 1 = left most inverter module.
- 2 = middle inverter module in 62 or 64 drive.
- 2 = right inverter module in 61 or 63 drive.
- 3 = right inverter module in 62 or 64 drive.
- 5 = rectifier module.

ALARM 248, Illegal power section configuration

This alarm is only for 6x unit size drives. It is equivalent to Alarm 79. The report value in the alarm log indicates which power module generated the alarm:

- 1 = left most inverter module.
- 2 = middle inverter module in 62 or 64 drive.
- 2 = right inverter module in 61 or 63 drive.
- 3 = right inverter module in 62 or 64 drive.
- 5 = rectifier module.

8**ALARM 250, New spare part**

The power or switch mode power supply has been exchanged. The frequency converter model number must be restored in the EEPROM. Remember to select 'Save to EEPROM' to complete.

ALARM 251, New model number

The frequency converter has a new model number.



Index

A		Drive Control Tool DCT 10 71
Abbreviations And Standards	5	Drives With Factory Installed A1/B1 RFI Filter Option 16
Access To Control Terminals	32	Duct Cooling 61
Airflow	61	E
Alarm/Warning Code List	127	Earth Leakage Current 6
Alarms And Warnings	125	Earthing 16
Analog		ELCB Relays 16
Inputs.....	114	Electrical
Output.....	114	Installation..... 32, 35
Auto		Ratings..... 7
Tune.....	38	Electronic Waste 8
Tuning.....	71	Example Of Changing Parameter Data 76
B		External Fan Supply 18
Back Cooling	61	F
Branch Circuit Protection	19	Fault Messages 129
C		Floor Mounting 66
Cable		Fuses 19
Lengths And Cross Sections.....	113	Fusing 9
Positions.....	52	G
Cable-length And Cross-section	9	General
Cabling	9	Considerations..... 50
Changing		Warning..... 4
A Group Of Numeric Data Values.....	82	Gland/Conduit Entry - IP21 (NEMA 1) And IP54 (NEMA12) ... 63
A Text Value.....	82	Graphical Display 67
Data.....	81	H
Of Data Value.....	82	High-voltage Warning 4
Parameter Data.....	76	How
Coasting	70	To Connect A PC To The Drive..... 71
Communication Option	131	To Operate Graphical Keypad..... 67
Control		I
Cables.....	36, 35	Indexed Parameters 82
Card Performance.....	116	Indicator Lights (LEDs) 68
Card, 10 V DC Output.....	115	Input Polarity Of Control Terminals 36
Card, 24 V DC Output.....	115	Installation
Card, Serial Communication.....	114	At High Altitudes (PELV)..... 7
Card, USB Serial Communication.....	116	Of Mains Shield For Frequency Converters..... 66
Characteristics.....	115	On Pedestal..... 65
Terminals.....	32	On The Wall - IP21 (NEMA 1) And IP54 (NEMA 12) Units... 62
Cooling	61	IT Mains 16
Copyright, Limitation Of Liability And Revision Rights	4	L
D		Leakage Current 6
DC Link	129	LEDs 67
Digital		Lifting 41
Inputs.....	113	
Output.....	115	
Disposal Instruction	8	
Drip Shield Installation	64	



Index	AF-600 FP High Power Operating Instructions
Load Sharing.....	17
M	
Macros.....	78
Main	
Menu.....	75
Menu Mode.....	69, 81
Menu Structure.....	83
Mains	
Connection.....	18
Supply (L1, L2, L3):.....	113
Supply 3 X 525- 690 VAC.....	120
Mechanical	
Dimensions.....	48, 42
Installation.....	50
Motor	
Cable.....	17
Name Plate.....	38
Output.....	113
Protection.....	116
N	
Name Plate Data.....	38
O	
Output Performance (U, V, W).....	113
P	
Parallel Connection Of Motors.....	39
Parameter	
Data.....	76
Selection.....	81
Set-Up.....	73
PC Software Tools.....	71
Pedestal Installation.....	66
Planning The Installation Site.....	41
Potentiometer Reference.....	34
Power Connections.....	9
Profibus DP-V1.....	71
Protection And Features.....	116
Pulse	
Inputs.....	114
Start/Stop.....	34
Q	
Quick	
Menu.....	69, 75
Menu Mode.....	69, 76
Transfer Of Parameter Settings When Using Keypad.....	72
R	
Receiving The Frequency Converter.....	41
Relay Outputs.....	115
Residual Current Device.....	6
RS-485 Bus Connection.....	70
S	
Screened/armoured.....	36
Screening Of Cables.....	9
Serial Communication.....	116
Shielded Cables.....	16
Space.....	50
Speed Up/Down.....	34
Start/Stop.....	34
Status	
Status.....	68
Messages.....	67
Step-by-Step.....	82
Surroundings.....	116
Switches S201, S202, And S801.....	38
Switching Frequency.....	9
T	
Terminal	
Locations.....	53
Locations - Unit Size 4X.....	2
Torque	
Torque.....	16
Characteristics.....	113
For Terminals.....	16
Trendings.....	76
Two Ways Of Operating.....	67
U	
Unpacking.....	41
V	
Voltage	
Level.....	113
Reference Via A Potentiometer.....	34
W	
Wire Access.....	50

The instructions do not purport to cover all details or variations in equipment nor to provide for every possible contingency to be met in connection with installation, operation or maintenance. Should further information be desired or should particular problems arise which are not covered sufficiently for the purchaser's purposes, the matter should be referred to the GE company.

AF-600 FP is a trademark of the General Electric Company.

GE
41 Woodford Avenue
Plainville, CT 06062

www.geelectrical.com/drives



imagination at work

130R0135



DET-610b