

GE Consumer & Industrial
Electrical Distribution

AF-650 GP & AF-600 FP™ Profibus DP

Operating Instructions



imagination at work



Contents

1. Introduction	3
Safety Note	4
Technical Overview	7
Bus Topology	7
2. How to Install	11
Cabling	11
EMC Precautions	12
Connecting the Bus Line	14
3. How to Configure the System	17
Configure the PROFIBUS Network	17
Configure the Master	18
GSD File	18
Configure the Frequency Converter	23
VLT Parameters	23
LEDs	23
4. How to Control the Frequency Converter	25
PPO Types	25
Process Data	27
Reference Handling	27
Process Control Operation	29
Control Profile	30
PROFIdrive Control Profile	30
Danfoss FC Control Profile	36
Synchronize and Freeze	41
5. How to Access the Parameters	43
Parameter Access in General	43
DP V1 Parameter Access	44
How to Use the DP V1 Features for Parameter Access	46
PCV Parameter Access	55
6. Parameters	61
PROFIBUS-specific Parameter List	72
Object and Data Types Supported	73
7. Application Examples	75
E.g.: Process Data with PPO Type 6	75
E.g.: Control Word Telegram using PPO Type	77
E.g.: Status Word Telegram using PPO Type	78



E.g.: PLC Programming	79
8. Troubleshooting	81
Diagnosis	81
Troubleshooting	81
LED Status	81
No Communication with the Drive	83
Warning 34 Appears even though Communication is Established	84
Drive Will Not Respond to Control Signals	84
Alarm and Warning Words	87
Fault Messages via DP Diagnosis	89
Extended Diagnosis	90
Index	91



1. Introduction

1

1.1.1. Copyright, Limitation of Liability and Revision Rights

This publication contains information proprietary to Danfoss A/S. By accepting and using this manual the user agrees that the information contained herein will be used solely for operating equipment from Danfoss A/S or equipment from other vendors provided that such equipment is intended for communication with Danfoss equipment over a PROFIBUS serial communication link. This publication is protected under the Copyright laws of Denmark and most other countries.

Danfoss A/S does not warrant that a software program produced according to the guidelines provided in this manual will function properly in every physical, hardware or software environment.

Although Danfoss A/S has tested and reviewed the documentation within this manual, Danfoss A/S makes no warranty or representation, either express or implied, with respect to this documentation, including its quality, performance, or fitness for a particular purpose.

In no event shall Danfoss A/S be liable for direct, indirect, special, incidental, or consequential damages arising out of the use, or the inability to use information contained in this manual, even if advised of the possibility of such damages. In particular, Danfoss A/S is not responsible for any costs including but not limited to those incurred as a result of lost profits or revenue, loss or damage of equipment, loss of computer programs, loss of data, the costs to substitute these, or any claims by third parties.

Danfoss A/S reserves the right to revise this publication at any time and to make changes in its contents without prior notice or any obligation to notify previous users of such revisions or changes.



1.2.1. Safety Note

1

The voltage of the frequency converter is dangerous whenever connected to mains. Incorrect installation of the motor, frequency converter or fieldbus may cause damage to the equipment, serious personal injury or death. Consequently, the instructions in this manual, as well as national and local rules and safety regulations, must be complied with.

1.2.2. Safety Regulations

1. The frequency converter must be disconnected from mains if repair work is to be carried out. Check that the mains supply has been disconnected and that the necessary time has passed before removing motor and mains plugs.
2. The [STOP/RESET] key on the control panel of the frequency converter does not disconnect the equipment from mains and is thus not to be used as a safety switch. 3. Correct protective earthing of the equipment must be established, the user must be protected against supply voltage, and the motor must be protected against overload in accordance with applicable national and local regulations.
3. Correct protective earthing of the equipment must be established, the user must be protected against supply voltage, and the motor must be protected against overload in accordance with applicable national and local regulations.
4. The earth leakage currents are higher than 3.5 mA.
5. Protection against motor overload is not included in the factory setting. If this function is desired, set par. 1-90 *Motor Thermal Protection* to data value *ETR trip* or data value *ETR warning*. Note: The function is initialised at 1.16 x rated motor current and rated motor frequency. For the North American market: The ETR functions provide class 20 motor overload protection in accordance with NEC.
6. Do not remove the plugs for the motor and mains supply while the frequency converter is connected to mains. Check that the mains supply has been disconnected and that the necessary time has passed before removing motor and mains plugs.
7. Please note that the frequency converter has more voltage inputs than L1, L2 and L3, when load sharing (linking of DC intermediate circuit) and external 24 V DC have been installed. Check that all voltage inputs have been disconnected and that the necessary time has passed before commencing repair work.

1.2.3. Warning Against Unintended Start

1. The motor can be brought to a stop by means of digital commands, bus commands, references or a local stop, while the frequency converter is connected to mains. If personal safety considerations make it necessary to ensure that no unintended start occurs, these stop functions are not sufficient.
2. While parameters are being changed, the motor may start. Consequently, the stop key [STOP/RESET] must always be activated; following which data can be modified.
3. A motor that has been stopped may start if faults occur in the electronics of the frequency converter, or if a temporary overload or a fault in the supply mains or the motor connection ceases.

1.2.4. Warning



Touching the electrical parts may be fatal - even after the equipment has been disconnected from mains.

Also make sure that other voltage inputs have been disconnected, such as external 24 V DC, load sharing (linkage of DC intermediate circuit), as well as the motor connection for kinetic back up.

Please refer to the relevant Operating Instructions for further safety guidelines.



1.3. About this Manual

First time users can obtain the most essential information for quick installation and set-up in these chapters:

Introduction

How to Install

How to Configure the System

Application Examples

For more detailed information including the full range of set-up options and diagnosis tools please refer to the chapters:

How to Control the Frequency Converter

How to Access the Parameters

Parameters

Troubleshooting

1.4. About PROFIBUS

PROFIBUS is standardized in the international standards IEC 61158 and IEC 61784, and supported by the member companies of the PROFIBUS International user community.

PROFIBUS International (PI) is the umbrella organization for all Regional PROFIBUS Associations (RPA) worldwide. PI has engaged PNO (PROFIBUS Nutzerorganisation e. V.), Germany, a non-profit organisation based in Karlsruhe, Germany, to establish Technical Committees and Working Groups in order to define and maintain the open and vendor independent PROFIBUS technology. Any member of PROFIBUS International may take an active part in maintenance and further development of the PROFIBUS technology. This guarantees openness and vendor independence of the PROFIBUS technology.

For access to the vast quantity of PROFIBUS literature including information and downloads for PROFIBUS DP and the PROFdrive profile, please refer to www.profibus.com.

1.5. About PROFIBUS DP V1

By operating the frequency converter via a field bus you can reduce the capital cost of your SYSTEM, communicate faster and more efficiently, and enjoy an easier user interface.

Using PROFIBUS DP V1 you are additionally guaranteed a product which has wide compatibility, a high level of availability and support, and which will be compatible with future versions. 10.

With the MCT 10 PC software tool you can control and configure your SYSTEM simultaneously, and monitor the entire SYSTEM more effectively for faster diagnosis, and better preventive maintenance. Simplify commissioning, maintenance and documentation using MCT.



Features of PROFIBUS DP V1:

Capital savings

- PROFIBUS DP V1 permits very effective use of PLC I/O capacity, in effect expanding the volume capacity of your existing PLC by up to two-thirds.

Fast and efficient communication

- short bus cycle times
- improved network efficiency

Easy to use

- transparent installation, diagnosis and parameterisation

Flexibility and compatibility

- Two different state machines can be selected: PROFIdrive profile or Danfoss FC profile
- Communication using PROFIBUS DP V1, Master Class 1 and Master Class 2

Future-proof investment

- Downward compatibility: New protocol extensions retain all the functions of the previous versions
- Continuous development of new application-oriented profiles
- Wide product availability
- Intelligent base for future technologies such as OPC, FDT/DTM, PROFINET

Technical features:

- Bus time out reaction
- PLC/CPU stop reaction
- Eight PPO types available
- Numerous relevant process data (PCD) types available
- Automatic detection of baud rate and PPO type
- Extended diagnosis available
- Alarms and warnings available as text messages within the PLC
- Equidistant bus cycle time configurable in PLC SYSTEM
- Improved network efficiency, since the cyclic parameter channel is no longer required
- Very short bus cycle times compared to industrial ethernet
- Backwards compatibility with DP

Features of MCT 10:

- Project-oriented PC tool, one tool for all VLT series
- Links to all Windows applications possible
- Supports Siemens CPs 5511 (PCMCIA) and 5611 (PCI- card), for PROFIBUS DP V1 Master Class 2 connection
- Support of standard interfaces: COMx, USB, RS232 (FLUX)
- Siemens PG / Field PGs already have the necessary hardware
- "View" is highly individually configurable
- Backwards compatibility with Dos-Dialog (*.mnu) and WinDialog (*.vlt)

1.6. Technical Overview

1.6.1. Bus Topology

Single master

- PLC communicates with telegrams of constant length
- Fits time-critical requirements
- Cyclical transmission via PPO types
- Extended diagnosis

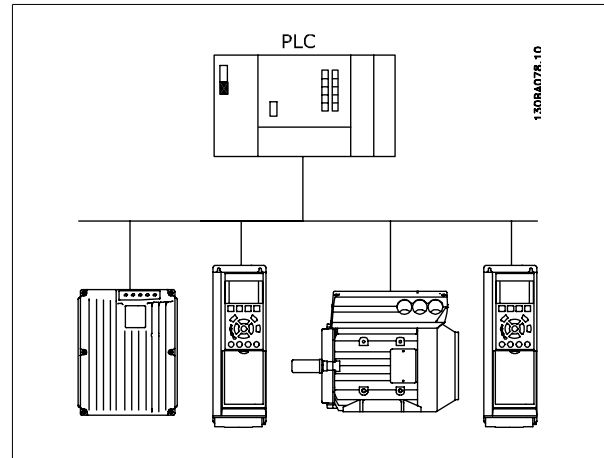

Illustration 1.1: PROFIBUS DP V0

1.6.2. Bus Topology

Multiple master

Features of a Master class 1 connection

- Cyclical data exchange (DP V0)
- Acyclical read/write on parameters
- Extended diagnosis

The acyclical connection is fixed, and cannot be changed during operation.

Features of a Master class 2 connection:

- Initiate / Abort acyclical connection
- Acyclical read/write on parameters

The acyclical connection can be established (Initiate) or removed (Abort) dynamically even when a master class 1 is active on the network. The DP V1 acyclical connection can be used for general parameter access as an alternative to the PCV parameter channel.

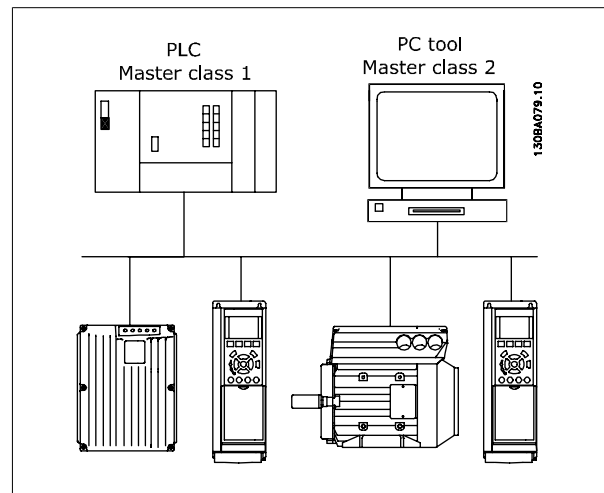

Illustration 1.2: PROFIBUS DP V1

The PROFIBUS DP extension DP V1 permits acyclical as well as cyclical data communication. This feature can be used by a DP master class 1 (e.g. PLC), as well as a DP master class 2 (e.g. PC tool).



1.7. Assumptions

1 This manual assumes you are using a DANFOSS PROFIBUS Option Card in conjunction with a DANFOSS FC 100, 200 or 300 Series. It is also assumed that your master is a PLC or PC equipped with a serial communication card supporting all the PROFIBUS communication services required by your application, and that all requirements stipulated in the PROFIBUS standard, as well as those set up in the PROFIBUS Variable Speed Drive Profile and its company-specific implementation PROFIdrive, as well as those pertaining to the VLT Variable Speed Drive are strictly observed as well as all limitations therein fully respected.

1.8. Hardware

These Operating Instructions relate to the Profibus fieldbus option type no. 130B1100 and type no. 130B1200.
The Profibus Option will be identified as: MCA 101 Profibus DP V1 in par. 15-60 *Option in Slot A*.

1.9. Background Knowledge

The DANFOSS PROFIBUS Option Card is designed to communicate with any master complying with the PROFIBUS standard. Familiarity with the PC or PLC you intend to use as a master in your SYSTEM is assumed. Issues regarding hardware or software produced by other manufacturers are beyond the scope of this manual, and are not the responsibility of DANFOSS.

If you have questions regarding set-up of master-to-master communication, or communication to a non-Danfoss slave, please consult the appropriate manuals

1.10. Available Literature

The following literature is available for the FC 100, 200 and 300 series.

Title	Literature no.
VLT HVAC Drive FC 100 Operating Instructions	MG.11.AX.YY
VLT HVAC Drive FC 100 Design Guide	MG.11.BX.YY
VLT HVAC Drive FC 100 Programming Guide	MG.11.CX.YY
VLT AQUA Drive FC 200 Operating Instructions	MG.20.NX.YY
VLT AQUA Drive FC 200 Design Guide	MG.20.MX.YY
VLT AQUA Drive FC 200 Programming Guide	MG.20.OX.YY
VLT AutomationDrive FC 300 Operating Instructions	MG.33.AX.YY
VLT AutomationDrive FC 300 Design Guide	MG.33.BX.YY
VLT AutomationDrive FC 300 Programming Guide	MG.33.MX.YY
VLT AutomationDrive FC 100, 200 and 300 PROFIBUS Operating Instructions	MG.33.CX.YY
VLT AutomationDrive FC 100, 200 and 300 DeviceNet Operating Instructions	MG.33.DX.YY
VLT AutomationDrive FC 300 MCT 10 Software Dialogue	MG.33.EX.YY
PROFIBUS DP V1 Design Guide	MG.90.EX.YY

X = Revision number

Y = Language code

Please also refer to www.danfoss.com/drives for frequently asked questions and additional information.



1.11. Abbreviations

1

ACI	Acyclical Control Interval
AOC	Application Orientated Controller
CAN	Controller Area Network
CTW	Control Word
DP	Distributed Periphery
DU	Data Unit
EEPROM	Electrical Erasable Programmable Read Only Memory
EIA	Electronic Industries Alliance: Specifier of the EIA Standard RS 485-A
EMC	Electromagnetic Compatibility
FDL	Fieldbus Data Link Layer
FDT	Field Device Tool
IND	Sub index
ISO	International Standards Organization
LCD	Liquid Crystal Display
LCP	Local Control Panel
LED	Light Emitting Diode
MAV	Main Actual Value
MC1	Master Class 1
MC2	Master Class 2
MOC	Motion Orientated Controller
MRV	Main Reference Value
PB	PROFIBUS
PC	Personal Computer
PCD	Process Data
PCA	Parameter Characteristics
PCV	Parameter-Characteristics-Value
PDU	Protocol Data Unit
PLC	Programmable Logic Control
PNU	Parameter Number
PPO	Parameter-Process Data
PVA	Parameter Value
RC	Request/Response Characteristics
SAP	Service Access Point
SMP	Spontaneous Message
STW	Status Word





2. How to Install

2.1. Cabling

2

2.1.1. Cable Lengths and Number of Codes

The maximum cable length allowable in one segment is dependent on the transmission speed. The total cable length includes drop cables if any. A drop cable is the connection from the main bus cable to each node if a T-connection is used instead of permissible cable length and maximum number of nodes/frequency converters with 1, 2, 3 and 4 bus segments.

Drop cable connection (i.e. T-connection) beyond the cable lengths indicated is not recommended, due to the increased risk of reflection occurring. Instead, Danfoss recommends direct connection of the frequency converter.

Note that a repeater is a node in both of the two segments it connects. The number of frequency converters is based on a single master SYSTEM. If there are two or more masters (e.g. PC tools), the number of frequency converters must be reduced correspondingly.

Maximum total bus cable length:

Transmission speed	1 segment: 32 nodes (31 VLT) [m]	2 segments: 64 nodes (1 repeater, 61 VLT) [m]	3 segments: 96 nodes (2 repeaters, 91 VLT) [m]	4 segments: 128 nodes (3 repeaters, 121 VLT) [m]
9.6-187.5 kBaud	1000	2000	3000	4000
500 kBaud	400	800	1200	1600
1.5 Mbaud	200	400	600	800
3-12 MBaud	100	200	300	400

Total drop cable length limit per segment:

Transmission speed	Max. drop cable length per segment [m]
9.6-93.75 kBaud	96
187.5 kBaud	75
500 kBaud	30
1.5 Mbaud	10
3-12 MBaud	None

The length statements in the tables above are valid for bus cable with the following properties:

2

- Impedance: 135 to 165 ohm at a measuring frequency from 3 to 20 MHz
- Resistance: <110 ohm/km
- Capacitance: <30 pF/m
- Damping: max. 9 dB over the whole wire length
- Cross section: max. 0.34 mm², corresponding to AWG 22
- Cable type: twisted in pairs, 1 x 2, or 2 x 2, or 1 x 4 wires
- Screening: Copper-braided screen or braided screen and foil screen

Use of the same cable type throughout the entire network is recommended to avoid impedance mismatch.

The numbers on the following diagram indicate the maximum number of stations in each segment. They are not the station addresses, as each station in the network must have a unique address.

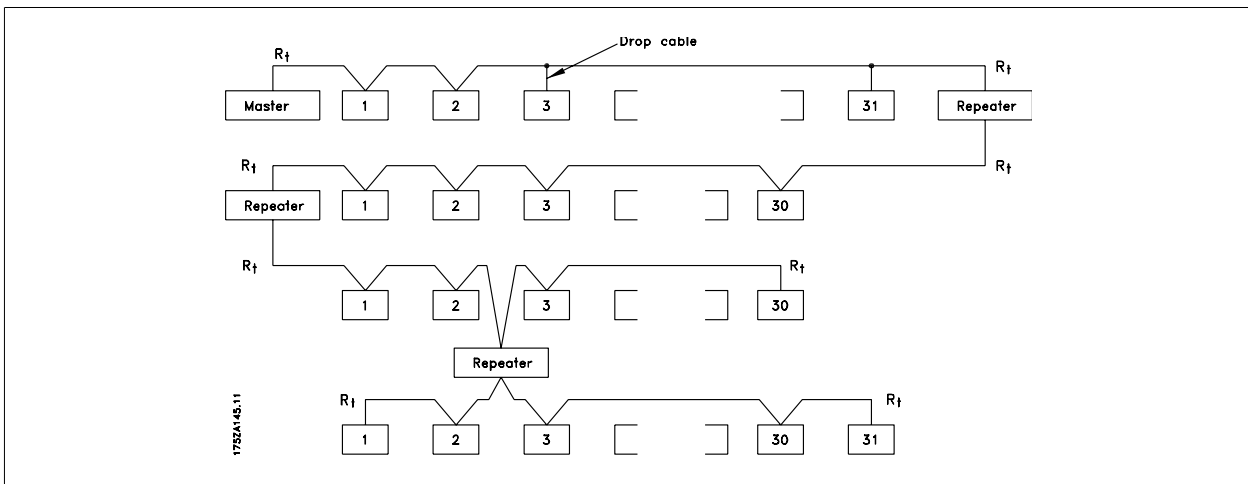

2.1.2. EMC Precautions

The following EMC precautions are recommended to achieve interference-free operation of the PROFIBUS network. Additional EMC information is available in the relevant FC 100, 200 or 300 series Operating Instructions (MG.11.AX.YY, MG.20.NX.YY or MG.33.AX.YY) and Design Guides (MG.11.BX.YY, MG.20.MX.YY or MG.33.BX.YY). Please also consult the PROFIBUS master manual for further installation guidelines.



NB!

Ensure compliance with relevant national and local regulations, for example in protective earth connection.

2.1.3. Connection of the Cable Screen

The screen of the PROFIBUS cable must always be connected to ground at both ends, meaning the screen must be connected to ground in all stations connected to the PROFIBUS network. It is very important to have a low impedance ground connection of the screen, also at high frequencies. This can be obtained by connecting the surface of the screen to ground, for example by means of a cable clamp or a conductive cable gland. The frequency converter has various clamps and brackets to enable a proper ground connection of the PROFIBUS cable screen. The screen connection is shown in the section *Connecting the Bus Line*.



2.1.4. Earth Connection

It is important that all stations connected to the PROFIBUS network are connected to the same earth potential. The earth connection must have a low HF (high frequency) impedance. This can be achieved by connecting a large surface area of the cabinet to earth, for example by mounting the frequency converter on a conductive rear plate. Particularly when there are long distances between the stations in a PROFIBUS network, it can be necessary to use additional potential equalizing cables, connecting the individual stations to the same earth potential.

2

2.1.5. Cable Routing

The PROFIBUS communication cable must be kept away from motor and brake resistor cables to avoid coupling of high frequency noise from one cable to the other. Normally a distance of 200 mm is sufficient, but maintaining the greatest possible distance between cables is generally recommended, especially where cables run in parallel over long distances.

If the PROFIBUS cable must cross a motor cable or brake resistor cable, the cables must cross at an angle of 90°.

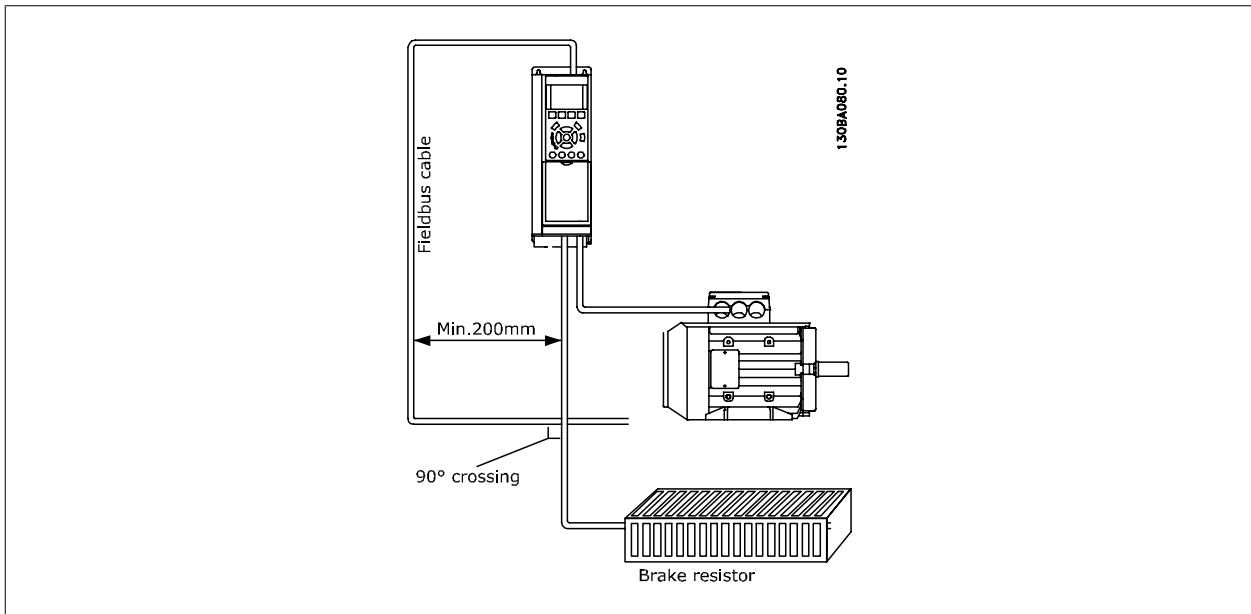



2.1.6. Connecting the Bus Line

Proper termination of the bus line is essential. A mismatch of impedance may result in reflections on the line that will corrupt data transmission.

2

- The PROFIBUS Option Card has a suitable termination, activated by switch 1 located on the Profibus option. The switches must be on to terminate the bus. The factory setting is off.
- Nodes at the physical ends of each segment must be terminated.
- When power to the PROFIBUS card is down, please note that the termination is still active, although not functional.
- Most masters and repeaters are equipped with their own termination.
- If an external termination circuit consisting of three resistors is connected to the bus line, a 5V DC power supply must be used. Please note that this power supply must be galvanically isolated from the a.c. line.
- The CS-pin on the Profibus connector is Control Select. When option goes into active state and sends a telegram, the CS pin goes high (+5 Volts). This can be used to control optical transmitters etc. or for triggering measurement equipment like an oscilloscope.
- D-sub 9 connector.
If desired, a D-sub 9 adaptor can be added as an option. The Profibus D-sub 9 adaptor has the type no: 130B1112.
N.B.: If the D-sub 9 adaptor is used, please be aware that the termination switch on the Profibus option is set to OFF, to avoid double termination. as the Profibus D-sub 9 connector also features a termination switch.

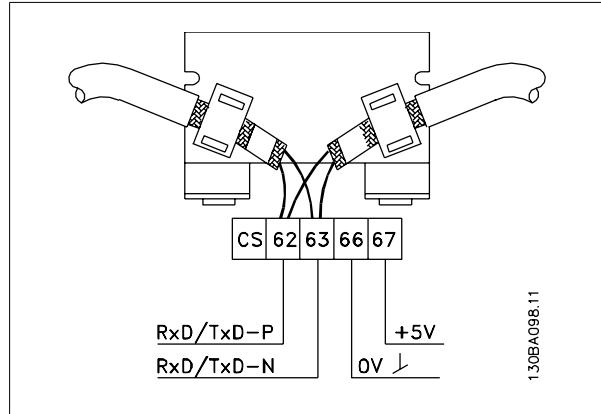
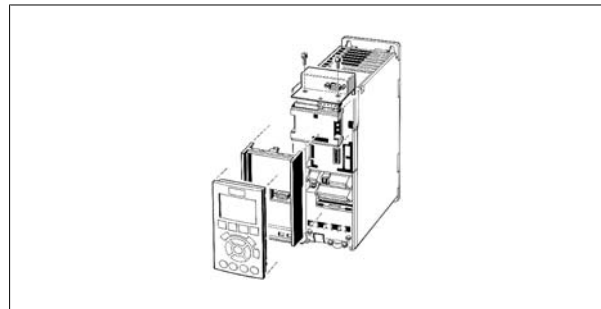
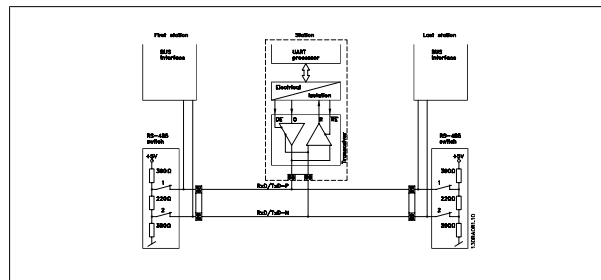

Illustration 2.1: 62 = RxD/TxD-P red cable (Siemens B)
63 = RxD/TxD-N green cable (Siemens A)





2.2. How to Install Option in Drive

To install a fieldbus option in the drive you will need:

- The fieldbus option
- Fieldbus option adaptor frame for the FC 100, 200 and 300. This frame is deeper than the standard frame, to allow space for the fieldbus option beneath
- Cable holders

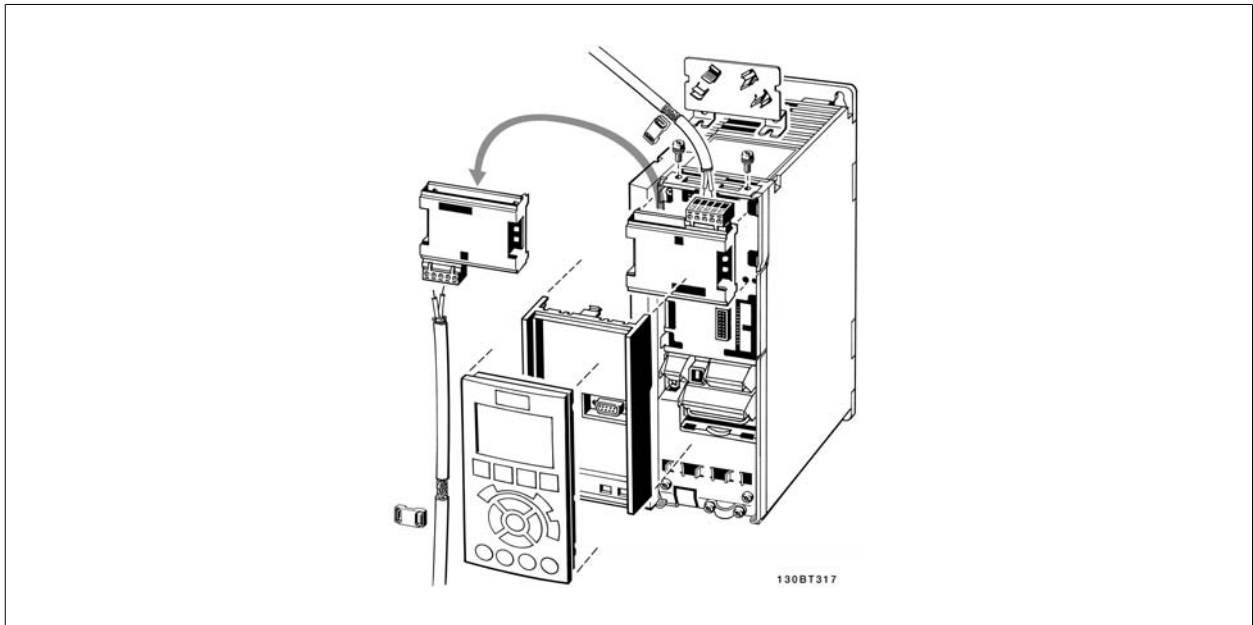
2

Instructions:

- Remove the LCD panel from the frequency converter
- Remove the frame located beneath and discard
- Push the option into place. Two positions are possible, with cable terminal facing either up or down. The cable up position is often most suitable when several frequency converters are installed side by side in a rack, as this position permits shorter cable lengths
- Push the fieldbus option adaptor frame into place
- Replace the LCD panel. - Attach cable
- Fasten the cable in place using cable holders
- The FC 100, 200 and 300 top surfaces have pre-bored threaded holes for attaching the cable holders to the unit





3. How to Configure the System

3.1. Configure the PROFIBUS Network

All PROFIBUS stations that are connected to the same bus network must have a unique station address.

The PROFIBUS address of the frequency converter can be selected via:

- Hardware switches
- Par. 9-18 Node address
- The PROFIBUS command SSA "Set Station Address"

3

3.1.1. Setting the PROFIBUS Address using the Hardware Switches

Using the hardware switches it is possible to select an address range from 0 to 125 (factory setting 127) according to the table below:

Switch	8	7	6	5	4	3	2	1
Address value	Not used	+64	+32	+16	+8	+4	+2	+1
E.g. address 5	Not used	OFF	OFF	OFF	OFF	ON	OFF	ON
E.g. address 35	Not used	OFF	ON	OFF	OFF	OFF	ON	ON
E.g. address 82	Not used	ON	OFF	ON	OFF	OFF	ON	OFF

**NB!**

Switch off the power supply before changing the hardware switches.

The address change will come into effect at the next power-up, and can be read in par. 9-18 *Node address*.

Note the location and sequence of the hardware switches as illustrated in the figure opposite.

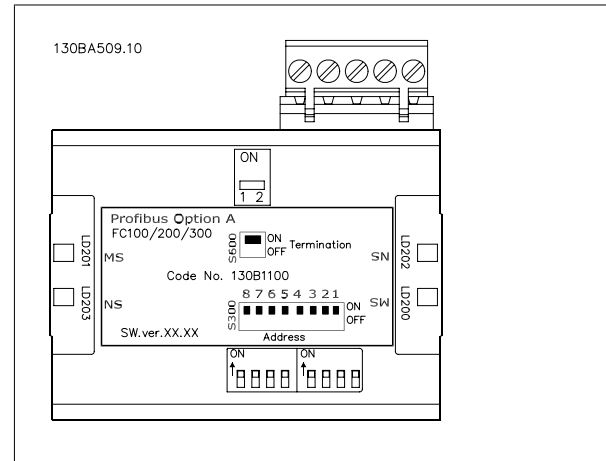



Setting the PROFIBUS Address via par. 9-18 Node address:

Setting the address via par. 9-18 Node address or the Profibus SSA-command is possible, if the hardware switches are set to 126 or 127 (factory switch setting). The address change will come into effect at the next power-up.

Setting the PROFIBUS Address with "Set Station Address" Command:

Setting the address via the "Set Station Address" command is possible, if the hardware switch is set to 126 or 127 (factory switch setting). Using the "Set Station Address" command it is possible to lock the programmed address, which makes it impossible to change the address using this command. The address setting can be unlocked by changing the par. 9-18 Node address or the address switch, followed by a power cycle. A new address is effective immediately after the "Set Station Address" command.

3

3.2. Configure the Master

3.2.1. GSD File

In order to configure a PROFIBUS Master, the configuration tool needs a GSD file for each type of slave on the network. The GSD file is a PROFIBUS DP "standard" text file containing the necessary communications setup data for a slave. Download the GSD file for the FC 100, 200 and 300 Drives at <http://www.danfoss.com/drives>.

Profibus SW Version (par. 15-61)	GSD file
1.x	da01040A.GSD
2.x	da02040A.GSD

The first step in configuration of the PROFIBUS Master is to import the GSD file in the configuration tool. The steps outlined below show how to add a new GSD file to the Simatic Manager software tool. For each drive series, a GSD file is typically imported once only, following the initial installation of the software tool.

Using the browser for the GSD file, choose to install All files, which will mean that both a GSD file and a bitmap for the device will be imported into the Hardware catalogue.

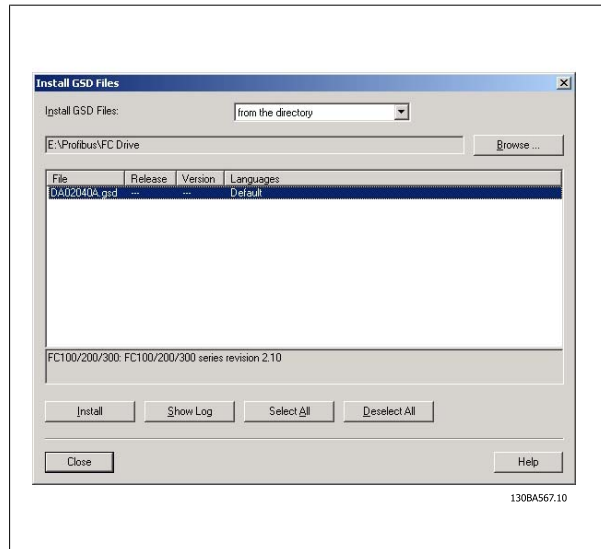
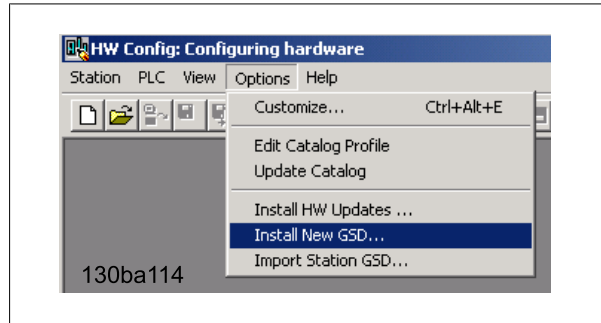



The FC 300 GSD file is now imported and will be accessible via the following path in the Hardware catalogue:

3

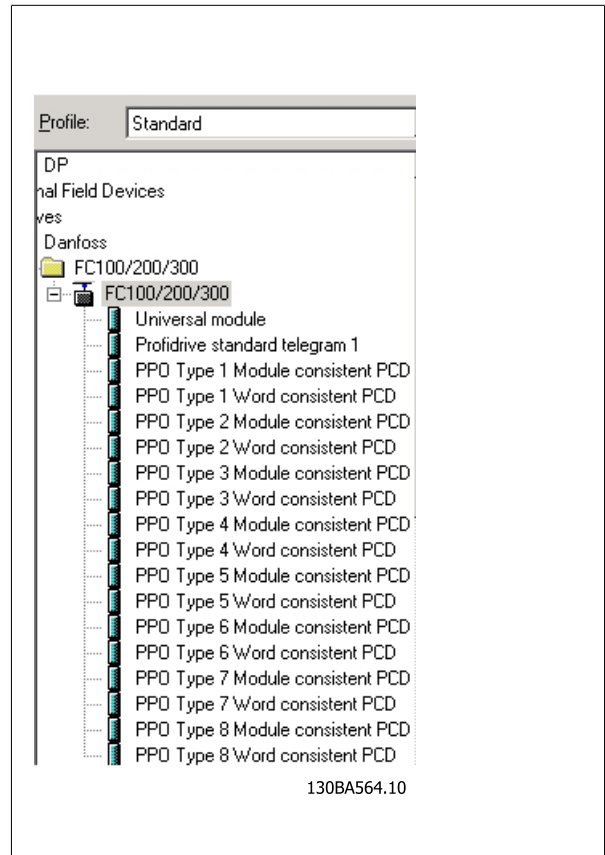
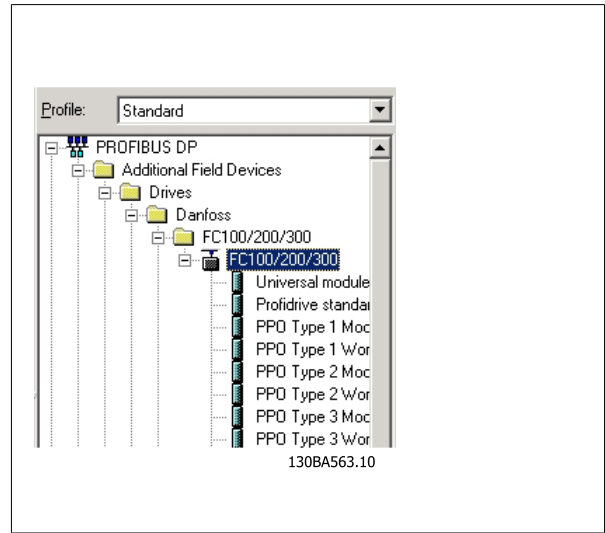

Open a Project, set up the Hardware and add a PROFIBUS Master SYSTEM. Select FC 300 then drag and drop it onto the PROFIBUS in the Hardware diagram.

A window for the address of the FC 300 now appears. Select the address from the scroll-down list. Note that this address setting must match the previous address setting in par. 9-18 *Node address*.

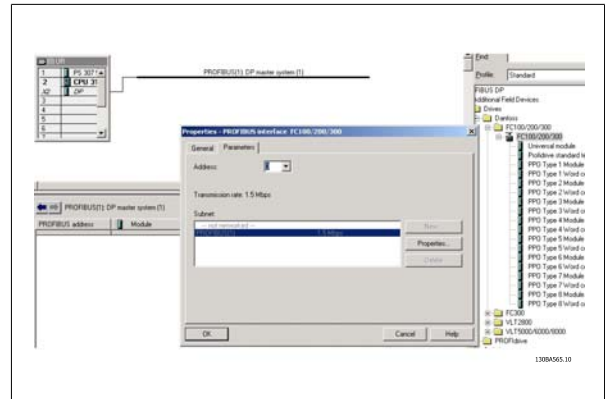





The next step is to set up the peripheral input and output data. Data set up in the peripheral area is transmitted cyclically via PPO types. In the example below, a PPO type 6 Word consistent is dragged and dropped to the first slot.

See the PPO types section in *How to Control the Frequency Converter* for more information.

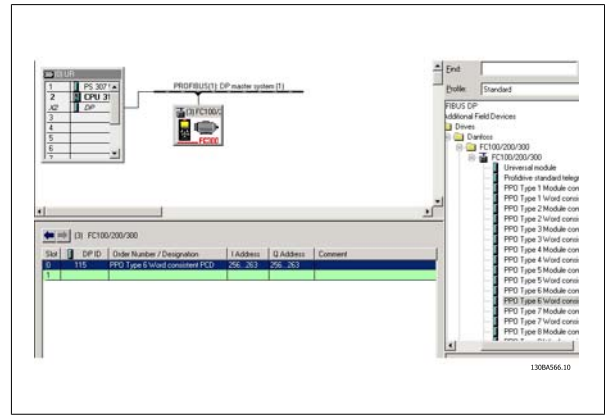

3

The configuration tool automatically assigns addresses in the peripheral address area. In this example the input and output area have the following configuration:

PPO type 6:

PCD word number	1	2	3	4
Input address	256-257	258-259	260-261	262-263
Set-up	STW	MAV	Par. 9-16.2	Par. 9-16.3

Table 3.1: PCD read (VLT to PLC)

PCD word number	1	2	3	4
Output address	256-257	258-259	260-261	262-263
Set-up	CTW	MRV	Par. 9-15.2	Par. 9-15.3

Table 3.2: PCD write (PLC to VLT)

For Profibus SW version 2.x and higher, Auto-configuration of process data is supported. This feature makes it possible to configure the process data (par. 9-15 and 9-16) from the PLC/Master. To use Autoconfig, make sure the feature under *DP slave Properties* is enabled.

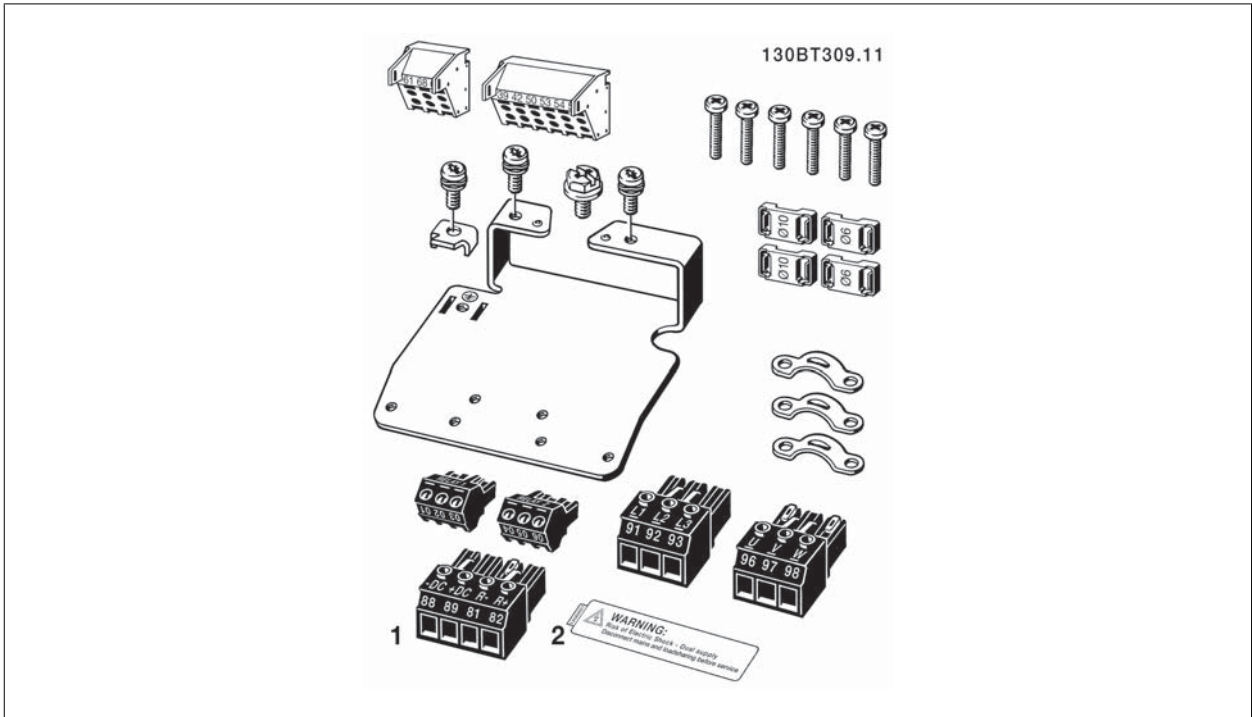



NB!

DP V1 diagnosis is supported for Profibus SW version 2 and higher. This means that the default setting of the Profibus option is DP V1 diagnosis. If DP V0 diagnosis is required, the setting under *DP slave Properties* must be changed

3

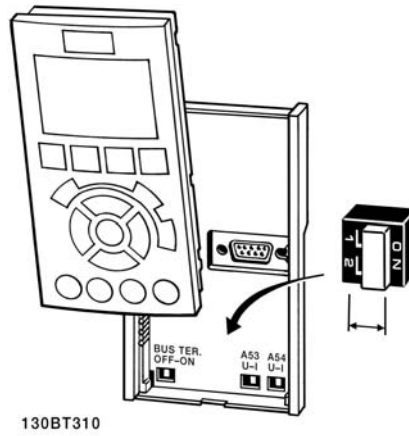

Download the configuration file to the PLC. The PROFIBUS SYSTEM should be able to go online and it will start to exchange data when the PLC is set to Run mode.



3.3. Configure the Frequency Converter

3.3.1. VLT Parameters

Pay particular attention to the following parameters when configuring the frequency converter with a PROFIBUS interface.

- Par. 0-40 [Hand on] key on LCP. If the Hand button on the frequency converter is activated, control of the drive via the PROFIBUS interface is disabled
- After an initial power up the frequency converter will automatically detect whether a fieldbus option is installed in slot A, and set par. 8-02 Control word source to [Option A]. If an option is added or changed in or removed from an already commissioned drive, it will not change par. 8-02 but enter Trip Mode, and the drive will display an error
- Par. 8-10 Control word profile. Choose between the Danfoss FC Profile and the PROFIdrive profile
- Par. 8-50 to 8-56. Selection of how to gate PROFIBUS control commands with digital input command of the control card

3



NB!
When par. 8-01 Control Site is set to [2] Control word only, then the settings in par. 8-50 to 8-56 will be overruled, and all act on Bus-control.

- Par. 8-03 to 8-05. The reaction in the event of a bus time out is set via these parameters
- Par. 9-18 Node address
- Par. 8-07 Diagnosis trigger

3.3.2. LEDs

The two bi-colour LEDs in the PROFIBUS card indicate the status of PROFIBUS communication

The LED marked "NS" indicates the network status, i.e. the cyclical communication to the PROFIBUS master. When this light shows constant green, then data exchange between the master and the frequency converter is active.

The LED marked "MS" indicates the module status, i.e. acyclical DP V1 communication from either a PROFIBUS master class 1 (PLC) or a master class 2 (MCT 10, FDT tool). When this light shows constant green, then DP V1 communication from master classes 1 and 2 is active.

For details of the full range of communications status indicated by the LEDs, please refer to the *Troubleshooting* chapter.

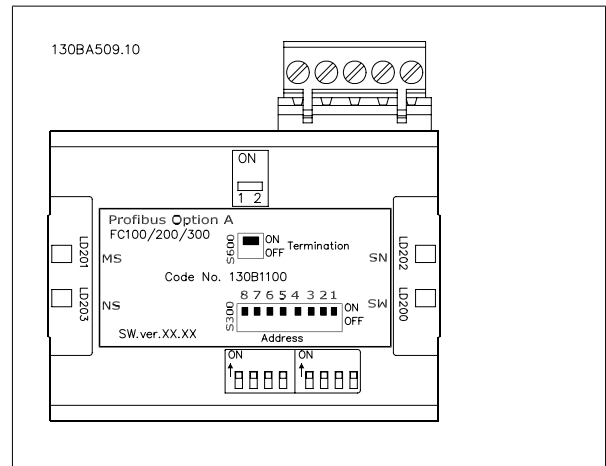





4. How to Control the Frequency Converter

4.1. PPO Types

The PROFIBUS profile for frequency converters specifies a number of communication objects (Parameter Process data Objects, PPO), which are suitable for data exchange between a process controller, such as a PLC, and frequency converters. All PPOs are defined for cyclic data transfer (i.e. DP V0), so that process data (PCD) and parameters (PCA) can be transferred from the master to the slave and vice versa. The figure below shows the PPO types available for the FC 100, 200 and 300.

PPO types 3, 4, 6, 7 and 8 are pure process data objects for applications requiring no cyclic parameter access. The PLC sends out process control data, and the frequency converter then responds with a PPO of the same length, containing process status data. The first two bytes of the process data area (PCD 1) comprise a fixed part present in all PPO types. The next two bytes (PCD 2) are fixed for PCD write entries (par. 9-15 [1]), but configurable for PCD read entries (par. 9-16 [1]). In the remaining bytes, from PCD 3 and on, the process data can be parameterised with process signals from the list on par. 9-23 *Parameters for Signal*.

Select the signals for transmission from the master to the frequency converter in par. 9-15 *PCD Write configuration* (request from master to the frequency converter). Select the signals for transmission from the frequency converter to the master in par. 9-16 *PCD Read configuration* (response: FC -> master).

PPO types 1, 2 and 5 consist of a parameter channel and process data. The parameter channel can be used for reading and/or updating of parameters (successively). Alternatively, for better utilisation of I/O and thus PLC capacity, parameters can be accessed via DP V1, in which case a pure process data object should be chosen (PPO type 3, 4, 6, 7 or 8).

The choice of PPO type is made in the master configuration, and is then automatically recorded in the frequency converter. No manual setting of PPO types in the frequency converter is required. The current PPO type can be read in par. 9-22 *Telegram selection*.

In addition, all PPO types can be set up as word consistent or module consistent. For FC 100, 200 and 300, the process data area can be word or module consistent, whereas the parameter channel must always be module consistent. Module consistent data is transmitted as sets of interrelated words transferred simultaneously between the PLC program and the frequency converter. Word consistent data is transmitted as individual independent words between the PLC and the frequency converter.

Selection [1] *Standard telegram 1* is equivalent to PPO type 3.



Byte no.	PCV								PCD																					
	1	2	3	4	5	6	7	8	9	10	11	12	13	14	15	16	17	18	19	20	21	22	23	24	25	26	27	28		
Par. 9-15 + 9-16 index no.:	PCA		IND		PVA				[0]	[1]		[2]	[3]	[4]	[5]	[6]	[7]	[8]	[9]											
Type 1:									CTW	STW	MRV	MAV	PCD	PCD	PCD	PCD	PCD	PCD	PCD	PCD	PCD	PCD	PCD	PCD	PCD	PCD	PCD	PCD	PCD	
Type 2:																														
Type 3:																														
Type 4:																														
Type 5:																														
Type 6:																														
Type 7:																														
Type 8:																														
PCV:	Parameter Characteristics Value								Control word																					
PCD:	Process Data								Status word																					
PCA:	Parameter Characteristics (Bytes 1, 2)																													
IND:	Sub index (Byte 3. Byte 4 is not used)																													
PVA:	Parameter value (Bytes 5 to 8)																													



4.2. Process Data

Use the process data part of the PPO for controlling and monitoring the frequency converter via the PROFIBUS.

4.2.1. Process Control Data

Process data sent from the PLC to the frequency converter is defined as Process Control Data (PCD).

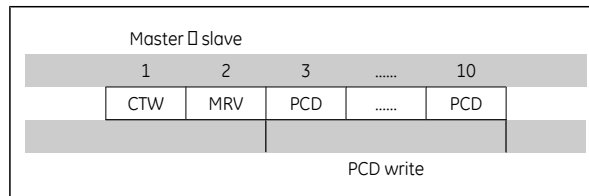

4

PCD 1 contains a 16-bit control word, where each bit controls a specific function of the frequency converter, see section *Control Profile*. PCD 2 contains a 16-bit speed set point in percentage format. See section *Reference Handling*

The content of PCD 3 to PCD 10 is programmed in par. 9-15 *PCD write configuration* and par. 9-16 *PCD read configuration*.

4.2.2. Process Status Data

Process data sent from the frequency converter contains information about the current state of the drive.

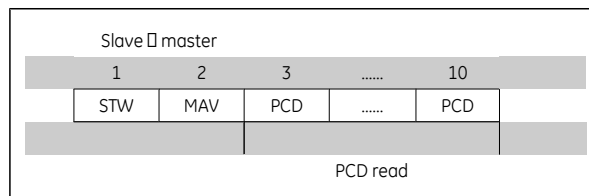

PCD 1 contains a 16-bit status word, where each bit contains information regarding a possible state of the frequency converter.

PCD 2 contains per default the value of the current speed of the frequency converter in percentage format (see section *Reference Handling*). PCD 2 can be configured to contain other process signals.

The content of PCD 3 to PCD 10 is programmed in par. 9-16 *PCD read configuration*.

4.2.3. Reference Handling

The reference handling in FC 100, 200 and 300 is an advanced mechanism that sums up references from different sources.

For more information on reference handling, please refer to the relevant FC 100, 200 or 300 Design Guides.

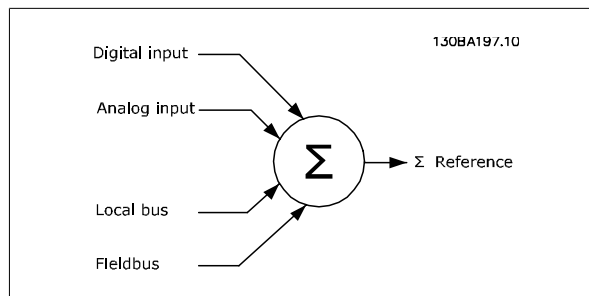

The reference, or speed set point (MRV, send via Profibus is always transmitted to the frequency converter in percentage format as integers represented in hexadecimal (0-4000 hex).

The reference (MRV) and feedback (MAV) are always scaled equally.

Depending on the setting of par. 3-00 *Reference Range* the reference and MAV are scaled accordingly:

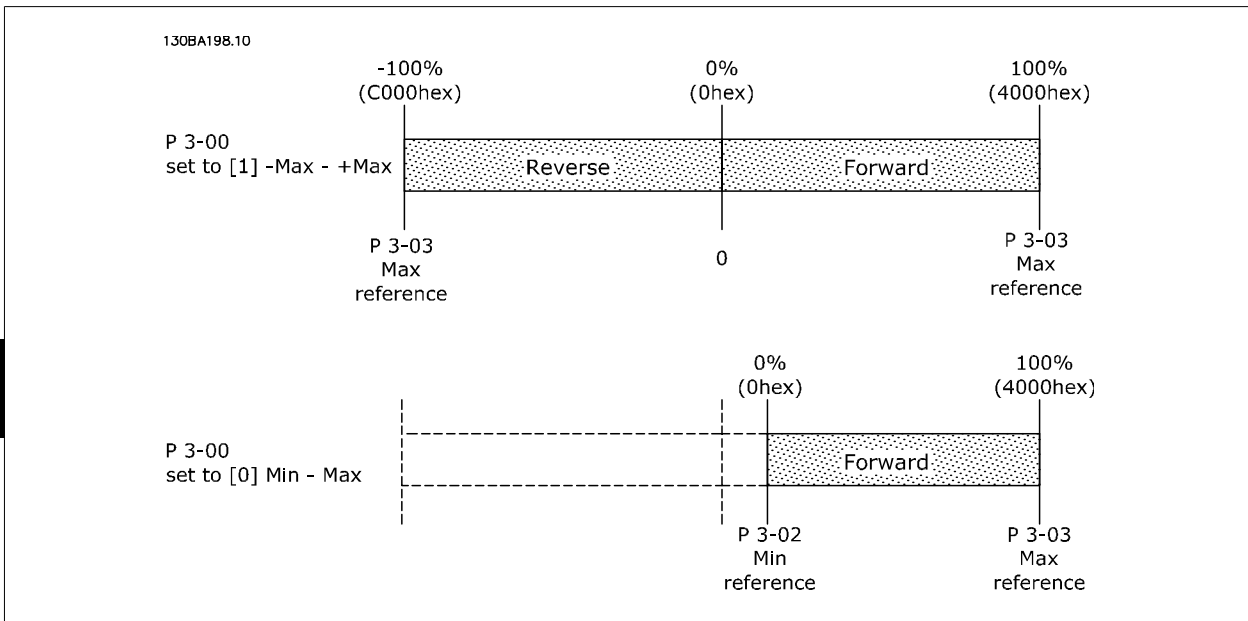

4

**NB!**

If par. 3-00 is set to [0] *Min - Max*, a negative reference will be handled as 0%.

The actual output of the frequency converter is limited by the speed limit parameters *Motor Low/High Speed Limit [RPM/Hz]* in par. 4-11 to 4-14.
The final speed limit is set by par. 4-19 *Max Output Frequency*.

The reference and the MAV have the format which appears from the table

MRV / MAV	Integer in hex	Integer in decimal
100%	4000	16.384
75%	3000	12.288
50%	2000	8.192
25%	1000	4.096
0%	0	0
-25%	F000	-4.096
-50%	E000	-8.192
-75%	D000	-12.288
-100%	C000	-16.384

**NB!**

Negative numbers are formed as two's complement.

**NB!**

The data type for MRV and MAV is a N2 16 bit standardised value, meaning it can express a range from -200% to +200% (8001 to 7FFF).

Par. 1-00 *Configuration Mode* set to [0] *Speed open loop*.

Par. 3-00 *Reference Range* set to [0] *Min - Max*.

Par. 3-02 *Min Reference* set to 100 RPM.

Par. 3-03 *Max Reference* set to 3000 RPM.



MRV / MAV		Actual Speed
0%	0 hex	100 RPM
25%	1000 hex	825 RPM
50%	2000 hex	1550 RPM
75%	3000 hex	2275 RPM
100%	4000 hex	3000 RPM

4.2.4. Process Control Operation

In process control operation par. 1-00 *Configuration Mode* is set to [3] *Process*.

The reference range in par. 3-00 is always [0] *Min - Max*.

- MRV represents the process setpoint.

- MAV expresses the actual process feedback (range +/- 200%).

4

4.2.5. Influence of the Digital Input Terminals upon FC Control Mode, Par. 8-50 to 8-56

The influence of the digital input terminals upon control of the frequency converter can be programmed in par. 8-50 to 8-56. Please note the par. 8-01 *Control Site* overrules the settings in par. 8-50 to 8-56, and Terminal 37 *Coasting Stop (safe)* overrules any parameter.

Each of the digital input signals can be programmed to logic AND, logic OR, or to have no relation to the corresponding bit in the control word. In this way a specific control command i.e. stop / coast, can be initiated by fieldbus only, fieldbus AND Digital Input, or Ether Fieldbus OR Digital input terminal.



In order to control the frequency converter via PROFIBUS, par. 8-50 *Coasting select* must be set to either Bus [1], or to Logic AND [2], and par. 8-01 *Control Site* must be set to [0] or [2].

More detailed information and examples of logical relationship options are provided in the *Troubleshooting chapter*.



4.3. Control Profile

The frequency converter can be controlled according to the PROFdrive profile, or the Danfoss FC profile. Select the desired control profile in par. 8-10 *Control word profile*. The choice of profile affects the control and status word only.

The *PROFdrive control profile* and *Danfoss FC control profile* sections provide a detailed description of control and status data.

4.4. PROFdrive Control Profile

4

4.4.1. PROFdrive Control Profile

This section describes the functionality of the control word and status word in the PROFdrive profile. Select this profile by setting par. 8-10 *Control word profile* to *PROFdrive*.

4.4.2. Control Word according to PROFdrive Profile (CTW)

The Control word is used to send commands from a master (e.g. a PC) to a slave.

Bit	Bit = 0	Bit = 1
00	OFF 1	ON 1
01	OFF 2	ON 2
02	OFF 3	ON 3
03	Coasting	No coasting
04	Quick stop	Ramp
05	Hold frequency output	Use ramp
06	Ramp stop	Start
07	No function	Reset
08	Jog 1 OFF	Jog 1 ON
09	Jog 2 OFF	Jog 2 ON
10	Data invalid	Data valid
11	No function	Slow down
12	No function	Catch up
13	Parameter set-up	Selection lsb
14	Parameter set-up	Selection msb
15	No function	Reverse

Explanation of the Control Bits

Bit 00, OFF 1/ON 1

Normal ramp stop using the ramp times of the actual selected ramp.

Bit 00 = "0" leads to the stop and activation of the output relay 1 or 2 if the output frequency is 0 Hz and if [Relay 123] has been selected in par. 5-40 *Function relay*.

When bit 00 = "1", the frequency converter is in State 1: "Switching on inhibited".

Please refer to the PROFdrive State Transition Diagram, at the end of this section.

Bit 01, OFF 2/ON 2

Coasting stop

When bit 01 = "0", a coasting stop and activation of the output relay 1 or 2 occurs if the output frequency is 0 Hz and if [Relay 123] has been selected in par. 5-40 *Function relay*.

When bit 01 = "1", the frequency converter is in State 1: "Switching on inhibited". Please refer to the PROFdrive State Transition Diagram, at the end of this section.

Bit 02, OFF 3/ON 3

Quick stop using the ramp time of par. 3-81 *Quick stop ramp time*. When bit 02 = "0", a quick stop and activation of the output relay 1 or 2 occurs if the output frequency is 0 Hz and if [Relay 123] has been selected in par. 5-40 *Function relay*.



When bit 02 = "1", the frequency converter is in State 1: "Switching on inhibited".
Please refer to the PROFIdrive State Transition Diagram, at the end of this section.

Bit 03, Coasting/No coasting

Coasting stop Bit 03 = "0" leads to a stop. When bit 03 = "1", the frequency converter can start if the other start conditions are satisfied.



NB!

The selection in par. 8-50 Coasting select determines how bit 03 is linked with the corresponding function of the digital inputs.

Bit 04, Quick stop/Ramp

Quick stop using the ramp time of par. 3-81 *Quick stop ramp time*.

When bit 04 = "0", a quick stop occurs.

When bit 04 = "1", the frequency converter can start if the other start conditions are satisfied.



NB!

The selection in par. 8-51 *Quick stop select* determines how bit 04 is linked with the corresponding function of the digital inputs.

Bit 05, Hold frequency output/Use ramp

When bit 05 = "0", the current output frequency is being maintained even if the reference value is modified.

When bit 05 = "1", the frequency converter can perform its regulating function again; operation occurs according to the respective reference value.

Bit 06, Ramp stop/Start

Normal ramp stop using the ramp times of the actual ramp as selected. In addition, activation of the output relay 01 or 04 if the output frequency is 0 Hz if Relay 123 has been selected in par. 5-40 *Function relay*. Bit 06 = "0" leads to a stop. When bit 06 = "1", the frequency converter can start if the other start conditions are satisfied.



NB!

The selection in par. 8-53 *Start select* determines how bit 06 is linked with the corresponding function of the digital inputs.

Bit 07, No function/Reset

Reset after switching off.

Acknowledges event in fault buffer.

When bit 07 = "0", no reset occurs.

When there is a slope change of bit 07 to "1", a reset occurs after switching off.

Bit 08, Jog 1 OFF/ON

Activation of the pre-programmed speed in par. 8-90 *Bus Jog 1 speed*. JOG 1 is only possible if bit 04 = "0" and bit 00 - 03 = "1".

Bit 09, Jog 2 OFF/ON

Activation of the pre-programmed speed in par. 8-91 *Bus Jog 2 speed*. JOG 2 is only possible if bit 04 = "0" and bit 00 - 03 = "1".

Bit 10, Data invalid/valid

Is used to tell the frequency converter whether the control word is to be used or ignored. Bit 10 = "0" causes the control word to be ignored, Bit 10 = "1" causes the control word to be used. This function is relevant, because the control word is always contained in the telegram, regardless of which type of telegram is used, i.e. it is possible to turn off the control word if you do not wish to use it in connection with updating or reading parameters.

Bit 11, No function/Slow down

Is used to reduce the speed reference value by the amount given in par. 3-12 *Catch up/slow down value*. When bit 11 = "0", no modification of the reference value occurs. When bit 11 = "1", the reference value is reduced.

Bit 12, No function/Catch up

Is used to increase the speed reference value by the amount given in par. 3-12 *Catch up/slow down value*.

When bit 12 = "0", no modification of the reference value occurs.

When bit 12 = "1", the reference value is increased.

If both - slowing down and accelerating - are activated (bit 11 and 12 = "1"), slowing down has priority, i.e. the speed reference value will be reduced.

Bits 13/14, Set-up selection

Bits 13 and 14 are used to choose between the four parameter set-ups according to the following table:

Set-up	Bit 13	Bit 14
1	0	0
2	1	0
3	0	1
4	1	1

The function is only possible if *Multi Set-up* has been chosen in par. 0-10 *Active set-up*. The selection in par. 8-55 *Set-up select* determines how bits 13 and 14 are linked with the corresponding function of the digital inputs. Changing set-up while running is only possible if the set-ups have been linked in par. 0-12 *This set-up linked to*.

Bit 15, No function/Reverse

Bit 15 = "0" causes no reversing.

Bit 15 = "1" causes reversing.

Note: In the factory setting reversing is set to *digital* in par. 8-54 *Reversing select*.

**NB!**

Bit 15 causes reversing only when *Ser. communication, Logic or or Logic and* is selected.

4



4.4.3. Status Word according to PROFIdrive Profile (STW)

The Status word is used to notify a master (e.g. a PC) about the status of a slave.

Bit	Bit = 0	Bit = 1
00	Control not ready	Control ready
01	Drive not ready	Drive ready
02	Coasting	Enable
03	No error	Trip
04	OFF 2	ON 2
05	OFF 3	ON 3
06	Start possible	Start not possible
07	No warning	Warning
08	Speed ≠ reference	Speed = reference
09	Local operation	Bus control
10	Out of frequency limit	Frequency limit ok
11	No operation	In operation
12	Drive OK	Stopped, autostart
13	Voltage OK	Voltage exceeded
14	Torque OK	Torque exceeded
15	Timer OK	Timer exceeded

4

Explanation of the Status Bits

Bit 00, Control not ready/ready

When bit 00 = "0", bit 00, 01 or 02 of the Control word is "0" (OFF 1, OFF 2 or OFF 3) - or the frequency converter is switched off (trip).

When bit 00 = "1", the frequency converter control is ready, but there is not necessarily power supply to the unit present (in the event of external 24 V supply of the control system).

Bit 01, VLT not ready/ready

Same significance as bit 00, however, there is a supply of the power unit. The frequency converter is ready when it receives the necessary start signals.

Bit 02, Coasting/Enable

When bit 02 = "0", bit 00, 01 or 02 of the Control word is "0" (OFF 1, OFF 2 or OFF 3 or coasting) - or the frequency converter is switched off (trip).

When bit 02 = "1", bit 00, 01 or 02 of the Control word is "1"; the frequency converter has not tripped.

Bit 03, No error/Trip

When bit 03 = "0", no error condition of the frequency converter exists.

When bit 03 = "1", the frequency converter has tripped and requires a reset signal before it can start.

Bit 04, ON 2/OFF 2

When bit 01 of the Control word is "0", then bit 04 = "0".

When bit 01 of the Control word is "1", then bit 04 = "1".

**Bit 05, ON 3/OFF 3**

When bit 02 of the Control word is "0", then bit 05 = "0".
When bit 02 of the Control word is "1", then bit 05 = "1".

Bit 06, Start possible/Start not possible

If PROFdrive has been selected in par. 8-10 *Control word profile*, bit 06 will be "1" after a switch-off acknowledgement, after activation of OFF2 or OFF3, and after switching on the mains voltage. Start not possible will be reset, with bit 00 of the Control word being set to "0" and bit 01, 02 and 10 being set to "1".

Bit 07, No warning/Warning

Bit 07 = "0" means that there are no warnings.
Bit 07 = "1" means that a warning has occurred.

Bit 08, Speed ≠ reference / Speed = reference

When bit 08 = "0", the current speed of the motor deviates from the set speed reference value. This may occur, for example, when the speed is being changed during start/stop through ramp up/down.
When bit 08 = "1", the current speed of the motor corresponds to the set speed reference value.

Bit 09, Local operation/Bus control

Bit 09 = "0" indicates that the frequency converter has been stopped by means of the stop button on the control panel, or that [Linked to hand] or [Local] has been selected in par. 3-13 *Reference site*.
When bit 09 = "1", the frequency converter can be controlled through the serial interface.

Bit 10, Out of frequency limit/Frequency limit OK

When bit 10 = "0", the output frequency is outside the limits set in par. 4-11 *Motor speed low limit (rpm)* and par. 4-13 *Motor speed high limit (rpm)*. When bit 10 = "1", the output frequency is within the indicated limits.

Bit 11, No operation/Operation

When bit 11 = "0", the motor does not turn.
When bit 11 = "1", the frequency converter has a start signal, or the output frequency is higher than 0 Hz.

Bit 12, Drive OK/Stopped, autostart

When bit 12 = "0", there is no temporary overloading of the inverter.
When bit 12 = "1", the inverter has stopped due to overloading. However, the frequency converter has not switched off (trip) and will start again after the overloading has ended.

Bit 13, Voltage OK/Voltage exceeded

When bit 13 = "0", the voltage limits of the frequency converter are not exceeded.
When bit 13 = "1", the direct voltage in the intermediate circuit of the frequency converter is too low or too high.

Bit 14, Torque OK/Torque exceeded

When bit 14 = "0", the motor torque is below the limit selected in par. 4-16 *Torque limit motor mode* and par. 4-17 *Torque limit generator mode*. When bit 14 = "1", the limit selected in par. 4-16 *Torque limit motor mode* or par. 4-17 *Torque limit generator mode* is exceeded.

Bit 15, Timer OK/Timer exceeded

When bit 15 = "0", the timers for the thermal motor protection and thermal frequency converter protection have not exceeded 100%.
When bit 15 = "1", one of the timers has exceeded 100%.

4.4.4. PROFdrive State - Transition Diagram

In the PROFdrive Control profile, the control bits 0 to 3 perform the basic start-up / power down functions, whereas the control bits 4 to 15 perform application-oriented control.

The figure below shows the basic state-transition diagram, where control bits 0 to 3 control the transitions, and the corresponding status bit indicates the actual state. The black bullets indicate the priority of the control signals, where fewer bullets indicate lower priority, and more bullets indicate higher priority.



130BA099.10

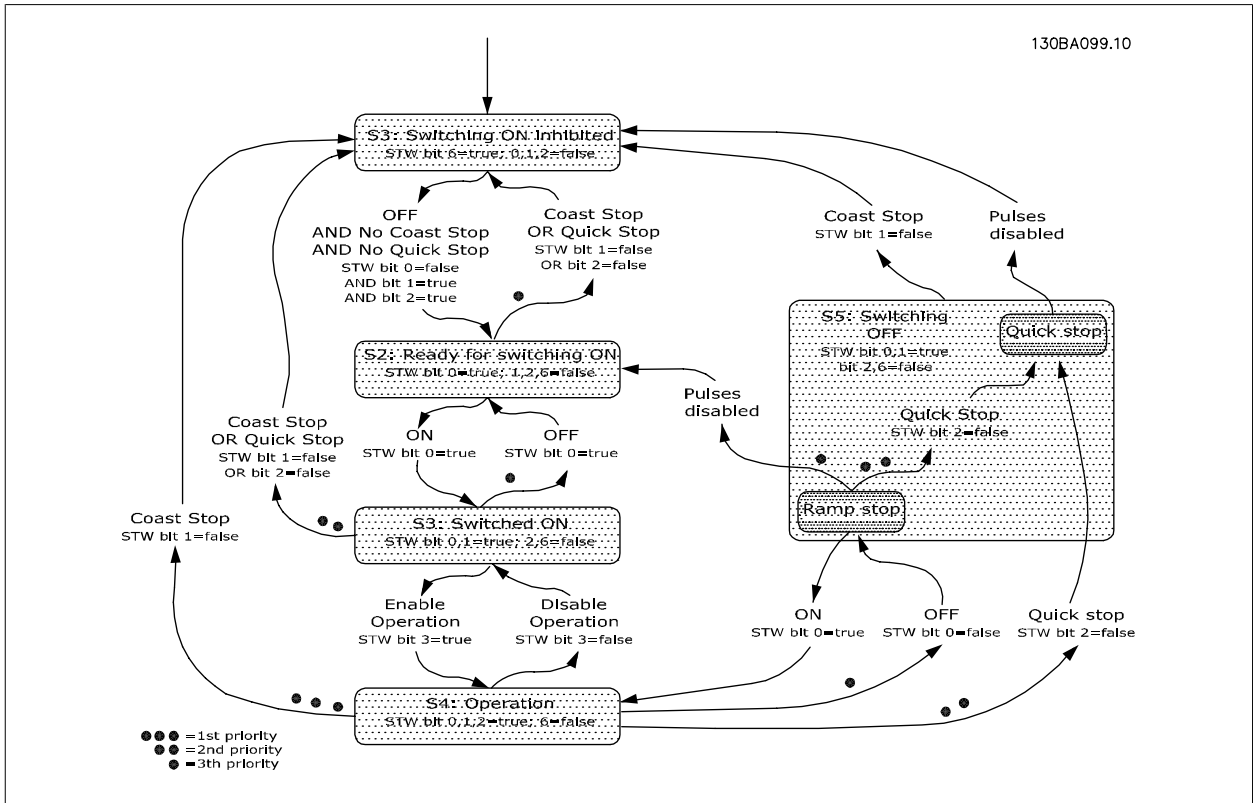



4.5. Danfoss FC Control Profile

4.5.1. Control Word according to FC Profile (CTW)

To select FC protocol in the control word, par. 8-10 *Control word profile* must be set to FC protocol [0]. The control word is used to send commands from a master (PLC or PC) to a slave (frequency converter).

Please refer to *Application Examples* for an example of a control word telegram using PPO type 3.

4

Bit	Bit value = 0	Bit value = 1
00	Reference value	external selection lsb
01	Reference value	external selection msb
02	DC brake	Ramp
03	Coasting	No coasting
04	Quick stop	Ramp
05	Hold output frequency	Use ramp
06	Ramp stop	Start
07	No function	Reset
08	No function	Jog
09	Ramp 1	Ramp 2
10	Data invalid	Data valid
11	No function	Relay 01 active
12	No function	Relay 04 active
13	Parameter set-up	selection lsb
14	Parameter set-up	selection msb
15	No function	Reverse

Explanation of the Control Bits

Bits 00/01 Reference value

Bits 00 and 01 are used to choose between the four reference values, which are pre-programmed in par. 3-10 *Preset reference* according to the following table:



NB!

In par. 8-56 *Preset reference select* a selection is made to define how Bit 00/01 gates with the corresponding function on the digital inputs.

Programmed ref. value	Parameter	Bit 01	Bit 00
1	3-10 [0]	0	0
2	3-10 [1]	0	1
3	3-10 [2]	1	0
4	3-10 [3]	1	1

Bit 02, DC brake

Bit 02 = "0" leads to DC braking and stop. Braking current and duration are set in par. 2-01 *DC Brake current* and 2-02 *DC Braking time*. Bit 02 = "1" leads to ramping.

Bit 03, Coasting

Bit 03 = "0" causes the frequency converter to immediately "let go" of the motor (the output transistors are "shut off"), so that it coasts to a standstill.

Bit 03 = "1" enables the frequency converter to start the motor if the other starting conditions have been fulfilled.

**NB!**

In par. 8-50 *Coasting select* a selection is made to define how Bit 03 gates with the corresponding function on a digital input.

Bit 04, Quick stop

Bit 04 = "0" causes a stop, in which the motor speed is ramped down to stop via par. 3-81 *Quick stop ramp time*.

Bit 05, Hold output frequency

Bit 05 = "0" causes the present output frequency (in Hz) to freeze. The frozen output frequency can then be changed only by means of the digital inputs (par. 5-10 to 5-15) programmed to *Speed up* and *Speed down*.

**NB!**

If *Freeze output* is active, the frequency converter can only be stopped by the following:

- Bit 03 Coasting stop
- Bit 02 DC braking
- Digital input (par. 5-10 to 5-15) programmed to *DC braking*, *Coasting stop* or *Reset and coasting stop*.

Bit 06, Ramp stop/start:

Bit 06 = "0" causes a stop, in which the motor speed is ramped down to stop via the selected *ramp down* parameter.

Bit 06 = "1" permits the frequency converter to start the motor, if the other starting conditions have been fulfilled.

**NB!**

In par. 8-53 *Start select* a selection is made to define how Bit 06 Ramp stop/start gates with the corresponding function on a digital input.

Bit 07, Reset

Bit 07 = "0" does not cause a reset. Bit 07 = "1" causes the reset of a trip. Reset is activated on the signal's leading edge, i.e. when changing from logic "0" to logic "1".

Bit 08, Jog

Bit 08 = "1" causes the output frequency to be determined by par. 3-19 *Jog speed*.

Bit 09, Selection of ramp 1/2

Bit 09 = "0" means that ramp 1 is active (parameters 3-40 to 3-47). Bit 09 = "1" means that ramp 2 (par. 3-50 to 3-57) is active.

Bit 10, Data not valid/Data valid

Is used to tell the frequency converter whether the control word is to be used or ignored. Bit 10 = "0" causes the control word to be ignored, Bit 10 = "1" causes the control word to be used. This function is relevant, because the control word is always contained in the telegram, regardless of which type of telegram is used, i.e. it is possible to turn off the control word if you do not wish to use it in connection with updating or reading parameters.

Bit 11, Relay 01

Bit 11 = "0" Relay not activated. Bit 11 = "1" Relay 01 activated, provided Control word bit 11 has been chosen in par. 5-40 *Function relay*.

Bit 12, Relay 04

Bit 12 = "0" Relay 04 has not been activated. Bit 12 = "1" Relay 04 has been activated, provided *Control word bit 12* has been chosen in par. 5-40 *Function relay*.

Bit 13/14, Selection of set-up

Bits 13 and 14 are used to choose from the four menu set-ups according to the following table:

The function is only possible when *Multi-Set-ups* is selected in par. 0-10 *Active Set-up*.

Set-up	Bit 14	Bit 13
1	0	0
2	0	1
3	1	0
4	1	1

**NB!**

In par. 8-55 *Set-up select* a selection is made to define how Bit 13/14 gates with the corresponding function on the digital inputs.

Bit 15 Reverse

Bit 15 = "0" causes no reversing.

Bit 15 = "1" causes reversing.



4.5.2. Status Word according to FC Profile (STW)

The status word is used to inform the master (e.g. a PC) of the operation mode of the slave (frequency converter).

Please refer to Application examples for an example of a status word telegram using PPO type 3.

Explanation of the Status Bits

Bit 00, Control not ready/ready

Bit 00 = "0" means that the frequency converter has tripped.

Bit 00 = "1" means that the frequency converter controls are ready, but that the power component is not necessarily receiving any power supply (in case of external 24 V supply to controls).

Bit 01, Drive ready

Bit 01 = "1". The frequency converter is ready for operation, but there is an active coasting command via the digital inputs or via serial communication.

Bit 02, Coasting stop

Bit 02 = "0". The frequency converter has released the motor.

Bit 02 = "1". The frequency converter can start the motor when a start command is given.

Bit 03, No error/trip

Bit 03 = "0" means that the frequency converter is not in fault mode.

Bit 03 = "1" means that the frequency converter is tripped, and that a reset signal is required to re-establish operation.

Bit 04, No error/error (no trip)

Bit 04 = "0" means that the frequency converter is not in fault mode.

Bit 04 = "1" means that there is a frequency converter error but no trip.

Bit 05, Not used

Bit 05 is not used in the status word.

Bit 06, No error / triplock

Bit 06 = "0" means that the frequency converter is not in fault mode.

Bit 06 = "1" means that the frequency converter is tripped, and locked.

Bit 07, No warning/warning

Bit 07 = "0" means that there are no warnings.

Bit 07 = "1" means that a warning has occurred.

Bit 08, Speed ≠ reference/speed = reference

Bit 08 = "0" means that the motor is running, but that the present speed is different from the preset speed reference. It might, for example, be the case while the speed is being ramped up/down during start/stop.

Bit 08 = "1" means that the present motor present speed matches the preset speed reference.

Bit 09, Local operation/bus control

Bit 09 = "0" means that [STOP/RESET] is activated on the control unit, or that *Local control* in par. 3-13 *Reference site* is selected. It is not possible to control the frequency converter via serial communication.

Bit 09 = "1" means that it is possible to control the frequency converter via the fieldbus/ serial communication.

Bit 10, Out of frequency limit

Bit	Bit = 0	Bit = 1
00	Control not ready	Control ready
01	Drive not ready	Drive ready
02	Coasting	Enable
03	No error	Trip
04	No error	Error (no trip)
05	Reserved	-
06	No error	Triplock
07	No warning	Warning
08	Speed ≠ reference	Speed = reference
09	Local operation	Bus control
10	Out of frequency limit	Frequency limit ok
11	No operation	In operation
12	Drive OK	Stopped, autostart
13	Voltage OK	Voltage exceeded
14	Torque OK	Torque exceeded
15	Timer OK	Timer exceeded



Bit 10 = "0", if the output frequency has reached the value in par. 4-11 *Motor speed low limit* or par. 4-13 *Motor speed high limit*.

Bit 10 = "1" means that the output frequency is within the defined limits.

Bit 11, No operation/in operation

Bit 11 = "0" means that the motor is not running.

Bit 11 = "1" means that the frequency converter has a start signal or that the output frequency is greater than 0 Hz.

Bit 12, Drive OK/stopped, autostart

Bit 12 = "0" means that there is no temporary over temperature on the inverter.

Bit 12 = "1" means that the inverter has stopped because of over temperature, but that the unit has not tripped and will resume operation once the over temperature stops.

Bit 13, Voltage OK/limit exceeded

Bit 13 = "0" means that there are no voltage warnings.

Bit 13 = "1" means that the DC voltage in the frequency converter's intermediate circuit is too low or too high.

Bit 14, Torque OK/limit exceeded

Bit 14 = "0" means that the motor current is lower than the torque limit selected in par. 4-16 *Torque limit motor mode* or par. 4-17 *Torque limit generator mode*.

Bit 14 = "1" means that the torque limit in par. 4-16 and 4-17 has been exceeded.

Bit 15, Timer OK/limit exceeded

Bit 15 = "0" means that the timers for motor thermal protection and VLT thermal protection, respectively, have not exceeded 100%.

Bit 15 = "1" means that one of the timers has exceeded 100%.



4.6. Synchronize and Freeze

The control commands SYNC/UNSYNC and FREEZE/UNFREEZE are broadcast functions.

SYNC/UNSYNC is used to synchronize control commands and/or speed reference to all the connected frequency converters.

FREEZE/UNFREEZE is used to freeze the status feedback in the slaves to get synchronized feedback from all connected slaves.

The synchronize and freeze commands affect only process data (the PCD part of the PPO).

4.6.1. SYNC/UNSYNC

SYNC/UNSYNC can be used to obtain simultaneous reactions in several slaves, for example synchronized start, stop or speed change. A SYNC command will freeze the relevant control word and speed reference. Incoming process data will be stored but not used until a new SYNC command or a UNSYNC command is received.

An UNSYNC command stops the synchronisation mechanism and enables normal DP data exchange.

4.6.2. FREEZE/UNFREEZE

FREEZE/UNFREEZE can be used for simultaneous reading of process data, for example output current, from several slaves.

A FREEZE command will freeze the actual values and upon request the slave will send back the value that was present when the FREEZE command was received.

Upon receipt of an UNFREEZE command the values will once again be continuously updated and the slave will return a present value, i.e. a value generated by conditions at present time.

The values will be updated when a new FREEZE or UNFREEZE command is received.





5. How to Access the Parameters

5.1. Parameter Access in General

In an automated SYSTEM, frequency converter parameters can be accessed either from the process controller (i.e. PLC), or from various kinds of HMI equipment. For parameter access from controllers and HMI, please observe the following:

FC 100, 200 and 300 parameters are located in four separate set-ups. Parameter access in the drive is performed via several separated parameter channels, which can be used individually to access a certain parameter set-up. Select the desired set-up in par. 0-11 *Edit set-up* or 9-70 *Parameter set-up selection*.

Using this mechanism it is possible to Read or Write to and from parameters in a certain set-up from a master class 1, e.g. a PLC, and simultaneously access parameters in a different set-up from a master class 2, e.g. a PC tool, without interfering with the set-up selection for the programming sources.

5

Parameters can be accessed via the following sites:

LCP on FC 100, 200 and 300

FC Protocol on RS485 or USB

Cyclical data access on DP V0 (PCV Channel)

PROFIBUS Master Class 1

PROFIBUS Master Class 2 (3 connections possible)



Please note that although these parameter channels are separated, data conflict can occur if write to parameters is made from a HMI unit into a set-up which is actively in use by the frequency converter or the process controller (e.g. a PLC).

5.1.1. Data Store

Parameter write via the PCV channel (DP V0) will be stored in RAM only. If data has to be stored in Non Volatile Memory, the par. 9-71 *PROFIBUS save data values* can be used for storing one or more set-ups.

Using DP V1 access, parameters can be stored either in RAM or Non-Volatile Memory by choice of a specific Write Request command. Non-stored data can at any time be stored in non-volatile memory by activating par. 9-71 *PROFIBUS save data values*.



5.1.2. Read / Write in Double Word Format, DP V1

Using the special Request IDs 0X51 (read) and 0X52 (write), it is possible to read and write to all parameters containing numeric values in a general format of Double Word. The value element must be right aligned and unused MSBs filled with zeros.

Example: Read of a parameter of type U8 will be transmitted as 00 00 00 xx, where xx is the value to be transmitted. The data type signalled by the telegram will be 43h (dword).

Please refer to the table *Request/ Response Attributes* later in this chapter.

Access the parameters as follows:

5.1.3. PROFIBUS DP V1

5

Using the acyclic DP V1 transmission it is possible to read and write parameter values, as well as to read a number of descriptive attributes for each parameter. Access to parameters via DP V1 is described in the *DP V1 Parameter Access* section.

5.1.4. PROFIBUS DP V0 / PCV Channel

Parameter access via the PCV channel is performed using PROFIBUS DP V0 cyclic data exchange, where the PCV channel is part of the PPOs described in the *PPO Types* section. Using the PCV channel, it is possible to read and write parameter values, as well as read a number of descriptive attributes for each parameter. The functionality of the PCV channel is described in the *PCV Parameter Access* section.

**NB!**

Object and data types supported by FC 100, 200 and 300 and common to both DP V1 and PCV parameter access are listed in the *Parameters* chapter.

5.2. DP V1 Parameter Access

This section is useful for the developer with some experience in:

- PLC programs with PROFIBUS master class 1 functionality
- PC applications with PROFIBUS master class 2 functionality

For more detailed instructions in use of the DP V1 function in FC 100, 200 and 300, please refer to the Operating Instructions MG.90.EX.YY *Information about the features supported by the PROFIBUS DP V1 functions*.

5.2.1. PROFIBUS DP V1 Introduction

The PROFIBUS DP extension DPV1 offers acyclical communication in addition to the cyclical data communication of DP V0. This feature is possible using a DP master class 1 (e.g. PLC), as well as a DP master class 2 (e.g. PC Tool).

Cyclical communication means that data transfer takes place continuously with a certain refresh rate. This is the known DP V0 function normally used for quick update of I/O Process Data.

Acyclical communication takes the form of a once-off data transfer event, mainly used for Read / Write from and to parameters from process controllers, PC-based tools or monitoring SYSTEMS.

5.2.2. Features of a Master Class 1 Connection

- Cyclical data exchange (DP V0)
- Acyclical read/write from and to parameters



In general a master class 1 is used as the process controller (either PLC or PC-based), responsible for commands, speed reference, status of the application, etc.. The master class 1 acyclical connection can be used for general parameter access in the slaves. However, the acyclical connection is fixed, and cannot be changed during operation.

5.2.3. Features of a Master Class 2 Connection

- Initiate / Abort acyclical connection
- Acyclical read/write from and to parameters

The master class 2 acyclical connection is typically used for configuration or commissioning tools for easy access to each parameter in any slave in the SYSTEM. The acyclical connection can be dynamically established (Initiate) or removed (Abort) even when a master class 1 is active on the network.

5.2.4. Services Overview for FC 100, 200 and 300

Master type	Service					
	Read	Write	Data transport	Initiate	Abort	Alarm
	<i>read data from slave</i>	<i>write data to slave</i>	<i>read and write data</i>	<i>open a connection</i>	<i>close a connection</i>	
Master Class 1	yes	yes	yes	-	-	-
Master Class 2	yes	yes	yes	yes	yes	-

5.2.5. Principle of Data Exchange by PROFIBUS DP V1

In a DP cycle the master class 1 (MC1) will first update the cyclical process data for all slaves in the SYSTEM. The MC1 can then send one acyclical message to one slave. If a master class 2 (MC2) is connected, the MC1 will hand over the bus rights to MC2, which will then be permitted to send one acyclical message to one slave. The token is then handed back to the MC1, and a new DP cycle begins.

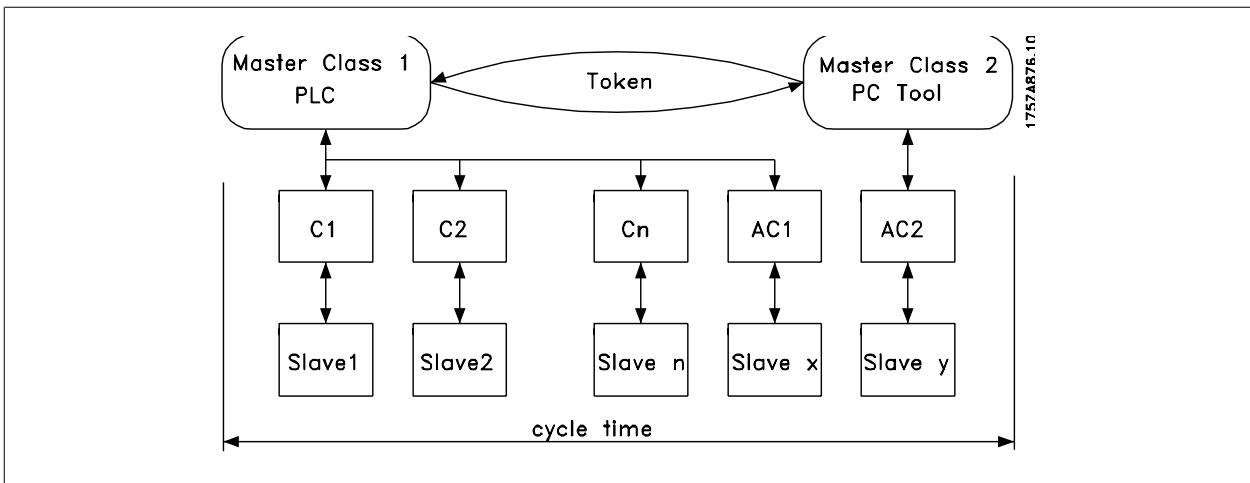

- MC : Master Class
- C1...Cn: Cyclical data
- AC1: Acyclical data Master Class 1
- AC2: Acyclical data Master Class 2

PROFIBUS DP services are activated via specific Service Access Points (SAP). For acyclical communication, the following SAP are specified:

Master SAP	Slave SAP	Meaning
50 (32H)	49 (31H)	Master Class 2: Initiate request
50 (32H)	0..48 (0..30H)	Master Class 2: Abort, Read, Write, Data transfer
51 (33H)	50, 51 (32H, 33H)	Master Class 2: Alarm
51 (33H)	51 (33H)	Master Class 2: Read, Write



5.2.6. How to Use the DP V1 Features for Parameter Access

This section describes how DP V1 can be used for accessing VLT parameters.

For units as complex as frequency converters, the standard PROFIBUS DP V1 read and write services are not sufficient for accessing the many parameters and attributes in the drive. For this reason, the PROFIdrive Parameter Channel is defined. Using this parameter Read/Write is performed by addressing a single DP V1 object in the frequency converter, in the following way:

Slot = 0

Index = 47

The telegram has the following general structure:

5

PROFIBUS Telegram Header				Data Unit				PROFIBUS Telegram Trailer	
DP V1 Command/response				PROFIdrive V3.0 Parameter Channel					
				DU	DU	DU	DU	Req. / Res. Header	Data
				0	1	2	3		

The DP V1 command/response part is used for the standard DP V1 read/Write on the Slot 0, Index 47 data block.

The PROFIdrive V3 Parameter Channel is used to access specific parameter data in the VLT.

For a detailed description of the DP V1 command handling, please refer to the PROFIBUS DP V1 Design Guide, ref. MG.90.EX.YY.

5.2.7. DP V1 Read / Write Services

The table below shows the content of the DP V1 command / Response headers and their possible attributes.

DU Byte	Value	Meaning	Specified
0	Function number	Idle REQ, RES	
	0x48		
	0x51	Data transport REQ, RES	
	0x56	Resource Manager REQ	
	0x57	Initiate REQ, RES	
	0x58	Abort REQ	
	0x5C	Alarm REQ, RES	
	0x5E	Read REQ, RES	
	0x5F	Write REQ, RES	
	0xD1	Data transport negative response	
	0xD7	Initiate negative response	
	0xDC	Alarm negative response	
	0xDE	Read negative response	
	0xDF	Write negative response	
1	Always zero	Slot number	DPV1
2	47	Index	DPV1
3	xx	Data length	DPV1
4..n		User data	PNO Drive Profile V3.0



5.2.8. How to Use the DP V1 Acyclical Parameter Channel

The PROFIdrive Parameter Channel should be used for read and write for FC 100, 200 and 300 parameters. The table below shows the structure of the PROFIdrive Parameter Channel. Using this it is possible to access the following VLT parameter values and attributes:

- Parameter values of simple variable, array and visible string
- Parameter description elements such as type, min./max. value, etc.
- Descriptive text for parameter values
- Access to multiple parameters in one telegram is also possible

PROFIBUS DP V1 telegram for read/write from or to a VLT parameter:

PROFIBUS Telegram Header				Data Unit				PROFIBUS Telegram Trailer	
				DP V1 Command/response				PROFIdrive V3.0 Parameter Channel	
				DU 0	DU 1	DU 2	DU 3	Req. / Res. Header	Data



The following table shows the principle structure of the PROFIdrive Parameter Channel.

The DP V1 Parameter Request telegram consists of 3 data blocks:

- a Request Header, which defines the kind of request (Read or Write), and the number of parameters to access. The master sets the Request Reference, and uses this information to evaluate the response
- an address field, where all addressing attributes of the desired parameters are defined
- a data field, where all parameter data values are placed

DP V1	Parameter request	Byte no.
Request header	Request reference	0
	Request ID	1
	Axis	2
Address field	No. of parameters	3
	Attribute	4
	No. of elements	5
	Parameter no.	6
		7
	Sub index	8
		9
	n'th parameter no.	$4+6*(n-1)$
		...
Data field	Data format	$4+6*n$
	No. of values	$(4+6*n)+1$
	Values	$(4+6*n)+2$
	n'th data value	...

5

The DP V1 Parameter response telegram consists of 2 data blocks:

- A response header, which indicates if the request is performed without errors (Response ID), the number of parameters, and the Request Reference set by the master within the corresponding request telegram
- A Data field, where the requested data are placed. If one or more internal requests have failed, an Error Code is placed instead of the data values

DP V1	Parameter response	Byte no.
Response header	Request ref. mirrored	0
	Response ID	1
	Axis mirrored	2
Parameter values	No. of parameters	3
	Format	4
	No. of values	5
	Values of error values	6
	n'th parameter value	...

As the response telegram does not include parameter addressing information, the master must identify the structure of the response data from the request telegram.



5.2.9. Request / Response Attributes

The table contains an overview of the possible attributes of the PROFIdrive parameter channel.

Field	Data type	Values	Remark
Request reference	Unsigned8	0x01..0xFF	
Request ID	Unsigned8	0x01	request parameter value
		0x02	change parameter value
		0x42	change parameter non-volatile
		0x51	request par. value double word
		0x52	change par. value double word
Response ID	Unsigned8	0x01	request parameter (+) Positive
		0x02	change parameter (+) Positive
		0x81	request parameter (-) Negative
		0x82	change parameter (-) Negative
Axis	Unsigned8	0x00..0xFF	number (always 0)
Number of parameters	Unsigned8	0x01..0x25	Limitation: DP V1 telegram length
Attribute	Unsigned8	0x10	value
		0x20	description
		0x30	text
Number of elements	Unsigned8	0x01-0xFA	Quantity 1-234 Limitation: DP V1 telegram length
Parameter number	Unsigned16	0x0001...	number 1-65535
		0xFFFF	
Subindex	Unsigned16	0x0000	number 0-65535
		0xFFFF	
Format	Unsigned8	See table	
Number of values	Unsigned8	0x01..0xEA	Quantity 0-234 Limitation: DP V1 telegram length
Error number	Unsigned16	0x0000...	Error number

5

5.2.10. Request Reference

Unique identification of request/response pair for the master. The master changes the request reference with each new request. The slave mirrors the request reference in the response.

5.2.11. Request ID

The following request identifications are defined:

0x01	Request parameter
0x02	Change parameter (Data are NOT stored in non-volatile memory, lost at power cycle)
0x42	Change parameter non-volatile (Data are stored in non-volatile memory)
0x51	Request parameter value double word. (All parameters are formatted and transferred as Double Word size, regardless of the actual data type)
0x52	Change parameter value double word. (All parameters must be formatted and sent as Double Word size, regardless of data type)

5.2.12. Response ID

The Response ID indicates if the Read or Write request was successfully performed in the frequency converter. If the response is negative, the request is answered negative (first bit = 1) and an error code is entered per partial response, instead of the value.

5.2.13. Axis

The axis attribute should be set to zero.

5.2.14. Number of Parameters

For multi-parameter requests specifying the number of the Parameter Address and/or Parameter Value areas. For a single request the number is 1.



5.2.15. Attribute

The attribute determines which kind of data to access. The frequency converter will respond to the attributes Value (10H), Description (20H) and Text (30H).

5.2.16. Attribute Value (10H)

The attribute value permits reading or writing of parameter values.

5.2.17. Attribute Description (20H)

The attribute description permits access to the parameter description. It is possible to read out one single description element, or all elements for one parameter in one telegram. The table below provides an overview of the existing Parameter Description, which exists for each parameter in the frequency converter.

5

Parameter description elements (all elements are read-only):

Sub-index	Meaning	Data Type
1	Identifier ID	V2
2	Number of array elements or length or string	U16
3	Standardization factor	float
4	Variable attribute	Octet string 2
5	Reserved	Octet string 4
6	Name	Visible string 16
7	Lower limit	Octet string 4
8	Upper limit	Octet string 4
9	Reserved	Octet string 2
10	ID extension	V2
11	PCD reference parameter	U16
12	PCD normalization	V2
0	Complete description	Octet string 46

In the following each description element is explained.

Identifier ID

Additional characteristics of a parameter.

Bit	Meaning
15	Reserved
14	Array
13	Parameter value can be reset only
12	Parameter has been changed from factory setting
11	Reserved
10	Additional text array available
9	Parameter is read-only
8	Standardization factor and variable attribute not relevant
0-7	Data type

Number of Array Elements

Contains the number of array elements, if the parameter is an array; the string length, if the parameter value is a string; or 0 if the parameter is neither.



Standardization Factor

Conversion factor for scaling a given parameter value to standard SI units.

For example, if the given value is in mV, the standardization factor will be 1000, which converts the given value to V.

The standardization factor is in Float format.

Variable Attribute

Consists of 2 bytes. The first byte contains the variable index, which defines the physical unit of the parameter (e.g. Ampere, Volt).

The second byte is the conversion index, which is a scaling factor for the parameter. In general all parameters accessible by PROFIBUS are organized and transmitted as real numbers. The conversion index defines a factor for conversion the actual value to a standard physical unit. (a conversion index of -1 means, that the actual value must be divided by 10 to become a standard physical unit e.g.. Volt.

5

Name

Contains the parameter name, limited to 16 characters, e.g. "LANGUAGE" for parameter 1. This text is available in the language selected in par 1.

Lower Limit

Contains the minimum value of the parameter. Format is 32 bit signed.

Upper Limit

Contains the maximum value of the parameter. Format is 32 bit signed.

ID Extension

Not supported

PCD Reference Parameter

Process data may be scaled by a parameter, e.g. the max reference of 0x4000 (in %) depends on the setting of parameter "X".

To enable the master to calculate the "real" value of the process data, it has to know the value of parameter "X", and therefore the process data must deliver a reference to parameter "X".

Field PCD Normalization

The field PCD normalization must express, in any case, the value that represents the 100 %, i.e. the normalization delivered back must be the set bit 15 and a value of 0xe (14, $2^{14} = 0x4000$), and the result must be 0x800e.

Complete Description

Returns the complete parameter description with the fields 1 to 12 in order. Length = 46 byte.



5.2.18. Attribute Text (30H)

For some frequency converter parameters a descriptive text is available, which can be read using this attribute. The availability of a text description for a parameter is indicated by a bit set in the Identifier (ID) Parameter Description element, which can be read out by the Description Attribute (20H) sub-index = 1. If bit 10 is set, a descriptive text exists for each value of the parameter.

As an example, par. 0-01 *Language* has settings from 0 to 5. For each of these values a specific text exists: 0 = ENGLISH, 2 = DEUTSCH, etc.

5.2.19. Format

Specifies the format type for each parameter (word, byte, etc.), see below.



5.2.20. Supported data types

Value	Data Type
3	Integer16
4	Integer32
5	Unsigned8
6	Unsigned16
7	Unsigned32
9	Visible string
10	Octet string (byte string)
33	N2 (standardised value)
35	V2 (bit sequence)
44	Error
54	Time difference without date indication

5.2.21. Value

The value field contains the parameter value of the request. When the response is negative, the field contains a corresponding error code. If the values consist of an odd number of bytes, a zero byte is appended in order to maintain the word structure of the telegrams.

For a positive partial response, the parameter value field contains the following attributes:

Format = (Data Type or Byte, Word, Double Word)

Number of values = actual number of values

Value = Parameter value

For a negative partial response, the parameter value field contains the following:

Format = error (44H)

Number of values = 1

Value = error value = error number

5.2.22. Error Number for Drive Profile V3.0

When the parameter request is invalid, the frequency converter will return a corresponding error code. The table below lists the full range of error codes.

Error codes for DP V1 parameter requests



Error code	Meaning	Additional Info
0x00	Unknown parameter	0
0x01	Parameter is read-only	sub-index
0x02	Value out of range due to max/min value	sub-index
0x03	Wrong sub-index	sub-index
0x04	Parameter is no array	0
0x05	Wrong data type (wrong data length)	0
0x06	This parameter may not be set, only reset	sub-index
0x07	Descriptive element is read-only	sub-index
0x09	No description available (only value)	0
0x0b	Process control not possible	0
0x0f	No text array available (only value)	0
0x11	Not possible in current state	0
0x14	Value out of range due to drive state/configuration	sub-index
0x15	Reply too long (more than 240 bytes)	0
0x16	Wrong parameter address (unknown or unsupported value for attribute, element, par. number or sub-index or illegal combination)	0
0x17	Illegal format (for writing)	0
0x18	Value amount not consistent	0
0x65	Wrong axis: action not possible with this axis	-
0x66	Unknown service request	-
0x67	This service is not possible with multi parameter access	-
0x68	Parameter value can not be read from bus	-



5.3. PCV Parameter Access

Parameter access via the PCV channel is performed by the PROFIBUS DP V0 cyclical data exchange, where the PCV channel is part of the PPOs described in the chapter How to Control the Frequency Converter.

PCV								PCD																				
PCA		IND		PVA				1	2	3	4	5	6	7	8	9	10											
								CTW	MRV	PCD	PCD	PCD	PCD	PCD	PCD	PCD	PCD											
								STW	MAV																			
Byte no.	1	2	3	4	5	6	7	8	9	10	11	12	13	14	15	16	17	18	19	20	21	22	23	24	25	26	27	28
Type 1:																												
Type 2:																												
Type 5:																												

5

PCV:	Parameter Characteristics Value
PCD:	Process Data
PCA:	Parameter Characteristics (Bytes 1, 2)
IND:	Sub index (Byte 3. Byte 4 is not used)
PVA:	Parameter value (Bytes 5 to 8)
CTW:	Control word
STW:	Status word
MRV:	Main reference value
MAV:	Main actual value (Actual output frequency)

Using the PCV channel it is possible to read and write parameter values, as well as readout of a number of describing attributes of each parameter.

5.3.1. PCA Handling

The PCA part of PPO types 1, 2 and 5 can handle several tasks. The master can control and supervise parameters and request a response from the slave, whereas the slave can respond to a request from the master.

Requests and responses is a handshake procedure and cannot be batched, meaning that if the master sends out a read/write request, it has to wait for the response, before it sends a new request. The request or response data value will be limited to maximum 4 bytes, which implies that text strings are not transferable. For further information, please see the *Application Examples chapter*.

5.3.2. PCA - Parameter Characteristics

15	14	13	12	11	10	9	8	7	6	5	4	3	2	1	0
RC				SMP	PNU										

RC: Request/response characteristics (Range 0..15)

SMP: Spontaneous Messag (Not supported)

PNU : Parameter no. (Range 1..1999)



5.3.3. Request / Response Handling

The RC portion of the PCA word defines the requests that may be issued from the master to the slave as well as what other portions of the PCV (IND and PVA) are involved. The PVA portion will transmit word-size parameter values in bytes 7 and 8, while long word size values require bytes 5 to 8 (32 bits). If the Response / Request contains array elements, the IND will carry the Array Sub-index. If parameter descriptions are involved, the IND will hold the Record Sub-index of the parameter description.

5.3.4. RC Content

5

If the slave rejects a request from the master, the RC word in the PPO-read will indicate this by assuming the value 7. The fault number will be carried by bytes 7 and 8 in the PVA element.

Request	Function
0	No request
1	Request parameter value
2	Change parameter value (word)
3	Change parameter value (long word)
4	Request description element
5	Change description element
6	Request parameter value (array)
7	Request parameter value (array word)
8	Request parameter value (array long word)
9	Request number of array elements
10-15	Not used

Response	Function
0	No response
1	Transfer parameter value (word)
2	Transfer parameter value (long word)
3	Transfer description element
4	Transfer parameter value (array word)
5	Transfer parameter value (array long word)
6	Transfer number of array elements
7	Request rejected (incl. fault #, see below)
8	Not serviceable by PCV interface
9	Not used
10	Not used
11	Not used
12	Not used
13-15	Not used

Fault no.	Interpretation
0	Illegal PNU
1	Parameter value cannot be changed
2	Upper or lower limit exceeded
3	Subindex corrupted
4	No array
5	Data type false
6	Cannot be set by user (reset only)
7	Description element cannot be changed
8	IR required PPO-write not available
9	Description data not available
10	Access group
11	No parameter write access
12	Key word missing
13	Text in cyclical transmission not readable
14	Name in cyclical transmission not readable
15	Text array not available
16	PPO-write missing
17	Request temporarily rejected
18	Other fault
19	Data in cyclical transmission not readable
130	There is no bus access to the parameter called
131	Data change is not possible because factory setup has been selected



5.3.5. Example

This example shows how to use PPO type 1 to change the ramp-up time (parameter 3-41 Ramp 1 ramp up time) to 10 seconds and to command a start and speed reference of 50%.

Frequency converter parameter settings:

Par. 8-50 *Coasting select*: Bus

Par. 8-10 *Control word profile*: PROFdrive profile

5.3.6. PCV

PCA – Parameter Characteristics

PCA part (byte 1-2).

The RC part tells what the PCV part must be used for. The functions available appear from the table, see *PCA handling*.

When a parameter is to be changed, choose value 2 or 3. In this example 3 is chosen, because par. 3-41 *Ramp 1 ramp up time* covers a long word (32 bits).

Par. 3-41 = 155 hex: In this example byte 1 and 2 are set to 3155.

IND (bytes 3-4):

Used when reading/changing parameters with sub-index, for example par. 9-15 *PCD write configuration*. In the example bytes 3 and 4 are set to 00 Hex.

PVA (bytes 5-8):

The data value of par. 3-41 *Ramp 1 ramp up time* must be changed to 10.00 seconds. The value transmitted must be 1000, because the conversion index for par. 3-41 *Ramp 1 ramp up time* is -2. This means that the value received by the frequency converter is divided by 100, such that the frequency converter perceives 1000 as 10.00. Bytes 5-8 = 1000 = 03E8 Hex. See *Object and Data types supported*.

5.3.7. PCD

Control word (CTW) according to PROFdrive profile:

Control words consist of 16 bits. The meaning of the each bit is explained in the section Control word and Status word. The following bit pattern sets all necessary start commands:

0000 0100 0111 1111 = 047F Hex.*

0000 0100 0111 1110 = 047E Hex.*

0000 0100 0111 1111 = 047F Hex.

Quick stop: 0000 0100 0110 1111 = 046F Hex.

Stop: 0000 0100 0011 1111 = 043F Hex.



NB!

* For restart after power up: Bit 1 and 2 of the CTW must be set to "1" and bit 0 toggled from "0" to "1".

5.3.8. MRV

Speed reference, the data format is "Standardized value". 0 Hex = 0% and 4000 Hex = 100%.

In the example, 2000 Hex is used, corresponding to 50% of maximum frequency (par. 3-03 *Max. Reference*).

The whole PPO therefore has the following values in Hex:



		Byte	Value
PCV	PCA	1	31
	PCA	2	55
	IND	3	00
	IND	4	00
	PVA	5	00
	PVA	6	00
	PVA	7	03
	PVA	8	E8
PCD	CTW	9	04
	CTW	10	7F
	MRV	11	20
	MVR	12	00

5



The process data within the PCD part acts immediately upon the frequency converter, and can be updated from the master as quickly as possible. The PCV part is a "handshake" procedure which means that the frequency converter has to acknowledge the command, before a new one can be written.

A positive response to the above example may look like this:

		Byte	Value
PCV	PCA	1	21
	PCA	2	55
	IND	3	00
	IND	4	00
	PVA	5	00
	PVA	6	00
	PVA	7	03
	PVA	8	E8
PCD	STW	9	0F
	STW	10	07
	MAV	11	20
	MAR	12	00

The PCD part responds according to the state and parameterisation of the frequency converter.

The PCV part responds as:

- PCA: As the request telegram, but here the RC part is taken from the response table, see the *PCA handling* section. In this example RC is 2 Hex, which is a confirmation that a parameter value of the type long word (32 bit) has been transferred. IND is not used in this example.
- PVA: 03E8Hex in the PVA part tells that the value of par. 3-41 *Ramp 1 ramp up time* is 1000, which corresponds to 10.00.
- STW: 0F07 Hex means that the motor is running and there are no warnings or faults (for details see the Status word table in the *Status word* section).
- MAV: 2000 Hex indicates that the output frequency is 50% of the maximum reference.

A negative response may look like this:

		Byte	Value
PCV	PCA	1	70
	PCA	2	00
	IND	3	00
	IND	4	00
	PVA	5	00
	PVA	6	00
	PVA	7	00
	PVA	8	02
PCD	STW	9	0F
	STW	10	07
	MAV	11	20
	MAR	12	00

RC is 7 Hex, which means that the request has been rejected, and the fault number can be found in the PVA part. In this case the fault number is 2, which means that the upper or lower limit of the parameter is exceeded. See the fault number table in the *PCA handling* section.





6. Parameters

O-01 Control Site

Option:
Function:

The setting in this parameter overrides the settings in par. O-50 *Coasting Select* to 8-56.

[0]	Digital and ctrl.word	Control by using both digital input and control word.
[1]	Digital only	Control by using digital inputs only.
[2]	Controlword only	Control by using control word only.

8-02 Control Word Source

Select the source of the control word: one of two serial interfaces or four installed options. During initial power-up, the frequency converter automatically sets this parameter to *Option A* [3] if it detects a valid fieldbus option installed in slot A. If the option is removed, the frequency converter detects a change in the configuration, sets par. 8-02 back to default setting *FC RS485*, and the frequency converter then trips. If an option is installed after initial power-up, the setting of par. 8-02 will not change but the frequency converter will trip and display: *Alarm 67 Option Changed*. This parameter cannot be adjusted while the motor is running.

[0]	None
[1]	FC RS485
[2]	FC USB
[3]	Option A
[4]	Option B
[5]	Option C0
[6]	Option C1
[30]	External Can

8-03 Control Word Timeout Time

Range:

1.0s* [0.1 - 18000.0 s]

Function:

Enter the maximum time expected to pass between the reception of two consecutive telegrams. If this time is exceeded, it indicates that the serial communication has stopped. The function selected in par. 8-04 will then be carried out. The time-out counter is triggered by a valid control word.

**8-04 Control Word Timeout Function**

Select the time-out function. The time-out function activates when the control word fails to be updated within the time period specified in par. 8-03.

- *Off* [0]: Resume control via serial bus (Fieldbus or standard) using the most recent control word.
- *Freeze output* [1]: Freeze output frequency until communication resumes.
- *Stop* [2]: Stop with auto restart when communication resumes.
- *Jogging* [3]: Run the motor at JOG frequency until communication resumes.
- *Max. freq.* [4]: Run the motor at maximum frequency until communication resumes.
- *Stop and trip* [5]: Stop the motor, then reset the frequency converter in order to restart: via the fieldbus, via the reset button on the Keypad or via a digital input.
- *Select set-up 1-4* [7] - [10]: This option changes the set-up upon reestablishment of communication following a control word time-out. If communication resumes causing the time-out situation to disappear, par. 8-05 defines whether to resume the set-up used before the time-out or to retain the set-up endorsed by the time-out function. Note the following configuration required in order to change the set-up after a time-out: Set Par. 0-10 to *Multi set-up* [9], and select the relevant link in par. 0-12.

6

[0] *	Off
[1]	Freeze Output
[2]	Stop
[3]	Jogging
[4]	Max. Speed
[5]	Stop and trip
[7]	Select set-up 1
[8]	Select set-up 2
[9]	Select set-up 3
[10]	Select set-up 4

0-05 End-of-Timeout Function**Option:****Function:**

Select the action after receiving a valid control word following a time-out. This parameter is active only when 0-04 *Control Timeout Function* is set to [Set-up 1-4].

[0]	Hold set-up	Retains the set-up selected in 0-04 <i>Control Timeout Function</i> and displays a warning, until 0-06 <i>Reset Control Timeout</i> toggles. Then the frequency converter resumes its original set-up.
[1]	Resume set-up	Resumes the set-up active prior to the time-out.

8-06 Reset Control Word Timeout

Select *Do reset* [1] to return the frequency converter to the original set-up following a control word time-out. When the value is set to *Do reset* [1], the frequency converter performs the reset and then immediately reverts to the *Do not reset* [0] setting. Select *Do not reset* [0] to retain the set-up specified in par. 8-04, following a control word time-out.

This parameter is active only when *Hold set-up* [0] has been selected in par. 8-05.

[0] *	Do not reset
[1]	Do reset



8-07 Diagnosis Trigger

Option:

Function:

Enables and controls the drive diagnosis function.

[0] * Disable Extended diagnosis data are not sent even if they appear in the frequency converter.

[1] Trigger on alarms Extended diagnosis data are sent when one or more alarms appear.

[2] Trigger alarms/warn. Extended diagnosis data are sent if one or more alarms/warnings appear.

See section *Extended Diagnosis* for explanation of the extended diagnosis frame.
Enabling diagnosis may cause increased bus traffic.

8-10 Control Word Profile

Select the interpretation of the control and status words corresponding to the installed fieldbus. Only the selections valid for the fieldbus installed in slot A will be visible in the Keypad display.

For guidelines in selection of *FC profile* [0] and *PROFdrive profile* [1] please refer to the *Serial communication via RS 485 Interface* section.

For additional guidelines in the selection of *PROFdrive profile* [1], *ODVA* [5] and *CANopen DSP 402* [7], please refer to the Operating Instructions for the installed fieldbus.

- [0] * FC profile
- [1] PROFdrive profile
- [5] ODVA
- [7] CANopen DSP 402

O-50 Coasting Select

Option:

Function:

Select control of the coasting function via the terminals (digital input) and/or via the bus.

[0] Digit Input

[1] Bus

[2] Logic AND

[3] Logic OR

8-51 Quick Stop Select

Option:

Function:

[0] Digital input

[1] Bus

[2] Logic AND

[3] * Logic OR

Select control of the Quick Stop function via the terminals (digital input) and/or via the bus.



NB!

This parameter is active only when par. 8-01 is set to [0] *Digital and control word*.

O-52 DC Brake Select

Option:

Function:

Select control of the DC brake via the terminals (digital input) and/or via the fieldbus.

[0] Digit Input

[1] Bus

[2] Logic AND

[3] Logic OR

**O-53 Start Select****Option:****Function:**

Select control of the frequency converter start function via the terminals (digital input) and/or via the fieldbus.

[0] Digit Input

[1] Bus

Activates Start command via the serial communication port or fieldbus option.

[2] Logic AND

Activates Start command via the fieldbus/serial communication port, AND additionally via one of the digital inputs.

[3] Logic OR

Activates Start command via the fieldbus/serial communication port OR via one of the digital inputs.

8-54 Reversing Select

Select control of the frequency converter reverse function via the terminals (digital input) and/or via the fieldbus.

Select *Bus* [1], to activate the Reverse command via the serial communication port or fieldbus option.Select *Logic AND* [2] to activate the Reverse command via the fieldbus/serial communication port, AND additionally via one of the digital inputs.Select *Logic OR* [3] to activate the Reverse command via the fieldbus/serial communication port OR via one of the digital inputs.

[0] Digital input

[1] Bus

[2] Logic AND

[3] * Logic OR

**NB!**This parameter is active only when par. 8-01 is set to [0] *Digital and control word*.

**O-55 Set-up Select****Option:****Function:**

Select control of the frequency converter set-up selection via the terminals (digital input) and/or via the fieldbus.

[0] Digit Input

[1] Bus

Activates the set-up selection via the serial communication port or fieldbus option.

[2] Logic AND

Activates the set-up selection via the fieldbus/serial communication port, AND additionally via one of the digital inputs.

[3] Logic OR

Activate the set-up selection via the fieldbus/serial communication port OR via one of the digital inputs.

O-56 Preset Reference Select**Option:****Function:**

Select control of the frequency converter Preset Reference selection via the terminals (digital input) and/or via the fieldbus.

[0] Digit Input

[1] Bus

Activates Preset Reference selection via the serial communication port or fieldbus option.

[2] Logic AND

Activates Preset Reference selection via the fieldbus/serial communication port, AND additionally via one of the digital inputs.

[3] Logic OR

Activates the Preset Reference selection via the fieldbus/serial communication port OR via one of the digital inputs.

O-90 Bus Jog 1 Speed**Range:****Function:**

100 RPM* [0 - par. H-13 RPM]

O-91 Bus Jog 2 Speed**Range:****Function:**

200 RPM* [0 - par. H-13 RPM]

9-15 PCD Write Configuration

Array [10]



None

3-02 Minimum Reference

3-03 Maximum Reference

3-12 Catch Up/Slow Down Value

3-41 Ramp 1 Ramp Up Time

3-42 Ramp 1 Ramp Down Time

3-51 Ramp 2 Ramp Up Time

3-52 Ramp 2 Ramp Down Time

3-80 Jog Ramp Time

3-81 Quick Stop Ramp Time

4-11 Motor Speed Low Limit [RPM]

4-13 Motor Speed High Limit [RPM]

4-16 Torque Limit Motor Mode

4-17 Torque Limit Generator Mode

7-28 Minimum Feedback

7-29 Maximum Feedback

8-90 Bus Jog 1 Speed

8-91 Bus Jog 2 Speed

16-80 Fieldbus CTW 1

16-82 Fieldbus REF 1

34-01 PCD 1 Write to MCO

34-02 PCD 2 Write to MCO

34-03 PCD 3 Write to MCO

34-04 PCD 4 Write to MCO

34-05 PCD 5 Write to MCO

34-06 PCD 6 Write to MCO

34-07 PCD 7 Write to MCO

34-08 PCD 8 Write to MCO

34-09 PCD 9 Write to MCO

34-10 PCD 10 Write to MCO

Select the parameters to be assigned to PCD 3 to 10 of the telegrams. The number of available PCDs depends on the telegram type. The values in PCD 3 to 10 will then be written to the selected parameters as data values. Alternatively, specify a standard Profibus telegram in par. 9-22.

9-16 PCD Read Configuration

Select the parameters to be assigned to PCD 3 to 10 of the telegrams. The number of available PCDs depends on the telegram type. PCDs 3 to 10 contain the actual data values of the selected parameters. For standard Profibus telegrams, see par. 9-22.

Array [10]



None
16-00 Control Word
16-01 Reference [Unit]
16-02 Reference %
16-03 Status Word
16-04 Main Actual Value [Unit]
16-05 Main Actual Value [%]
16-09 Custom Readout
16-10 Power [kW]
16-11 Power [hp]
16-12 Motor Voltage
16-13 Frequency
16-14 Motor Current
16-16 Torque
16-17 Speed [RPM]
16-18 Motor Thermal
16-19 KTY Sensor Temperature
16-21 Phase Angle
16-30 DC Link Voltage
16-32 Brake Energy / s
16-33 Brake Energy / 2 min 16-34
Heatsink Temp.
16-35 Inverter Thermal
16-38 SL Control State
16-39 Control Card Temp.
16-50 External Reference
16-51 Pulse Reference
16-52 Feedback [Unit]
16-53 Digi Pot Reference
16-60 Digital Input
16-61 Terminal 53 Switch Setting
16-62 Analog Input 53
16-63 Terminal 54 Switch Setting
16-64 Analog Input 54
16-65 Analog Output 42 [mA]
16-66 Digital Output [bin]
16-67 Freq. Input 29 [Hz]
16-68 Freq. Input 33 [Hz]
16-69 Pulse Output 27 [Hz]
16-70 Pulse Output 29 [Hz]
16-71 Pulse Output [bin]
16-84 Comm Option STW [Binary]
16-85 FC port CTW 1 Signal
16-90 Alarm Word
16-91 Alarm Word 2
16-92 Warning Word
16-93 Warning Word 2
16-94 Extended Status Word
16-95 Extended Status Word 2
34-21 PCD 1 Read from MCO
34-22 PCD 2 Read from MCO
34-23 PCD 3 Read from MCO
34-24 PCD 4 Read from MCO

**PB-18 Node Address****Range:**

[0 - 126. N/A]

Function:

Enter the station address in this parameter or alternatively in the hardware switch. In order to adjust the station address in par. PB-18 *Node Address*, the hardware switch must be set to 126 or 127 (i.e. all switches set to 'on'). Otherwise this parameter will display the actual setting of the switch.

PB-22 Telegram Selection**Option:****Function:**

Select a standard Profibus telegram configuration for the frequency converter, as an alternative to using the freely configurable telegrams in PB-15 *PCD Write Configuration* and PB-16 *PCD Read Configuration*.

[0] Freely configurable

[1] Standard telegram 1

[101] PPO 1

[102] PPO 2

[103] PPO 3

[104] PPO 4

[105] PPO 5

[106] PPO 6

[107] PPO 7

[108] PPO 8

[200] Custom telegram 1

6

9-23 Parameters for Signals

Array [1000]
Read only

This parameter contains a list of signals available for selection in par. 9-15 and par. 9-16.

PB-27 Parameter Edit**Option:****Function:**

Parameters can be edited via Profibus, the standard RS485 interface, or the Keypad.

[0] Disabled

Disables editing via Profibus.

[1] Enabled

Enables editing via Profibus.

[500] Dummy to get U16

PB-28 Process Control**Option:****Function:**

Process control (setting of Control Word, speed reference, and process data) is possible via either Profibus or standard fieldbus but not both simultaneously. Local control is always possible via the Keypad. Control via process control is possible via either terminals or fieldbus depending on the settings in par. 0-50 *Coasting Select* to par. 0-56 *Preset Reference Select*.

[0] Disable

Disables process control via Profibus, and enables process control via standard fieldbus or Profibus Master class 2.

[1] Enable cyclic master

Enables process control via Profibus Master Class 1, and disables process control via standard fieldbus or Profibus Master class 2.

[2] MCL2 control

[500] Dummy to get u16

**9-44 Fault Message Counter****Range:**

0* [0 - 8]

Function:

Indicates the number of fault events presently stored in par. 9-45. The buffer capacity is maximum eight error events.
The buffer and counter is set to 0 by reset or power-up.

9-45 Fault Code**Option:**

Array 64

Function:

This buffer contains the alarm-word for all alarms and warnings that have occurred since last reset or power-up.
The buffer capacity is maximum eight error events.

9-52 Fault Situation Counter**Range:**

0* [0 - 1000]

Function:

Indicates the number of fault events occurred since last reset or power-up.

PB-53 Profibus Warning Word**Range:**

[0 - 65535 N/A]

Function:

This parameter displays Profibus communication warnings. Please refer to the *Profibus Operating Instructions* for further information.

6

Read only

Bit:	Meaning:
0	Connection with DP-master is not ok
1	Not used
2	FDL (Field-bus Data link Layer) is not ok
3	Clear data command received
4	Actual value is not updated
5	Baudrate search
6	PROFIBUS ASIC is not transmitting
7	Initializing of PROFIBUS is not ok
8	Frequency converter is tripped
9	Internal CAN error
10	Wrong configuration data from PLC
11	Wrong ID sent by PLC
12	Internal error occurred
13	Not configured
14	Timeout active
15	Warning 34 active

PB-63 Actual Baud Rate**Option:**

[0] 9,6 kbit/s

[1] 19,2 kbit/s

[2] 93,75 kbit/s

[3] 187,5 kbit/s

[4] 500 kbit/s

[6] 1500 kbit/s

[7] 3000 kbit/s

[8] 6000 kbit/s

[9] 12000 kbit/s

[10] 31,25 kbit/s

[11] 45,45 kbit/s

[255] No baudrate found

Function:

This parameter displays the actual Profibus baud rate. The Profibus Master automatically sets the baud rate.

**9-64 Device Identification**

Array [10]

Read only

[10] Array

Index	Content	Value
[0]	Manufacturer	128 (for Danfoss)
[1]	Device type	1
[2]	Version	xyyy
[3]	Firmware date year	yyyy
[4]	Firmware date month	ddmm
[5]	No. of axes	variable
[6]	Vendor specific: PB Version	xyyy
[7]	Vendor specific: Database Version	xyyy
[8]	Vendor specific: AOC Version	xyyy
[9]	Vendor specific: MOC Version	xyyy

6

The device identification parameter. The data type is "Array[n] of Unsigned16". The assignment of the first subindexes is defined and shown in the table above.

**NB!**

This parameter is not visible via LCP.

PB-65 Profile Number**Range:**

[0 - 0 N/A]

Function:

This parameter contains the profile identification. Byte 1 contains the profile number and byte 2 the version number of the profile.

9-70 Edit Set-up**Option:**

- [0] Factory Set-up
- [1] Set-up 1
- [2] Set-up 2
- [3] Set-up 3
- [4] Set-up 4
- [9] * *Active set-up

Function:

Choose the set-up in which programming (change of data) will be performing during operation. It is possible to programme the 4 set-ups independently of the set-up selected as active. Parameter access from each master will be directed to the set-up which has been selected by the individual master (cyclic, acyclic MCL1, first acyclic MCL2, second acyclic MCL2, third acyclic MCL2). See section *Parameter Access in General*.

PB-71 Profibus Save Data Values**Option:**

- | | | |
|-----|------------------|--|
| | | Parameter values changed via Profibus are not automatically stored in non-volatile memory. Use this parameter to activate a function that stores parameter values in the EEPROM non-volatile memory, so changed parameter values will be retained at power-down. |
| [0] | Off | Deactivates the non-volatile storage function. |
| [1] | Store all setups | Stores all parameter values for all set-ups in the non-volatile memory. The selection returns to <i>Off</i> [0] when all parameter values have been stored. |
| [2] | Store all setups | Stores all parameter values for all set-ups in the non-volatile memory. The selection returns to <i>Off</i> [0] when all parameter values have been stored. |

**PB-72 ProfibusDriveReset****Option:****Function:**

[0] No action

[1] Power-on reset

Resets frequency converter upon power-up, as for power-cycle.

[2] Power-on reset prep

[3] Comm option reset

Resets the Profibus option only, useful after changing certain settings in parameter group 9-**, e.g. par. PB-18 *Node Address*.

When reset, the frequency converter disappears from the fieldbus, which may cause a communication error from the master.

PB-80 Defined Parameters (1)**Range:****Function:**

[0 - 9999 N/A]

PB-81 Defined Parameters (2)**Range:****Function:**

[0 - 9999 N/A]

PB-82 Defined Parameters (3)**Range:****Function:**

[0 - 9999 N/A]

PB-83 Defined Parameters (4)**Range:****Function:**

[0 - 9999 N/A]

PB-90 Changed Parameters (1)**Range:****Function:**

This parameter displays a list of all the frequency converter parameters deviating from default setting.

[0 - 9999 N/A]

PB-91 Changed Parameters (2)**Range:****Function:**

This parameter displays a list of all the frequency converter parameters deviating from default setting.

[0 - 9999 N/A]

PB-92 Changed Parameters (3)**Range:****Function:**

This parameter displays a list of all the frequency converter parameters deviating from default setting.

[0 - 9999 N/A]

PB-94 Changed Parameters (5)**Range:****Function:**

This parameter displays a list of all the frequency converter parameters deviating from default setting.

[0 - 9999 N/A]

16-84 Comm Option Status Word [Binary]**Range:****Function:**

0* [0 - FFFF]

Extended fieldbus comm. option status word. For more information - see section *Troubleshooting*.



DR-90 Alarm Word

Range:	Function:
[0 - 4294967295 N/A]	View the alarm word sent via the serial communication port in hex code.

DR-92 Warning Word

Range:	Function:
[0 - 4294967295 N/A]	View the warning word sent via the serial communication port in hex code.

6.3. PROFIBUS-specific Parameter List

6

Par. No. #	Parameter description	Default value	Range	Conversion index	Data type
8-01	Control Site	Dig. & ctrl. word [0]	[0 - 2]	-	UInt8
8-02	Control Word Source	FC RS485 [0]	[0 - 4]	-	UInt8
8-03	Control Word Timeout Time	1	0.1-18000	-1	UInt32
8-04	Control Word Timeout Function	Off [0]	[0 - 10]	-	UInt8
8-05	End of Timeout Function	Hold set-up [0]	[0 - 1]	-	UInt8
8-06	Reset Control Word Timeout	Do not reset [0]	[0 - 1]	-	UInt8
8-07	Diagnosis Trigger	Disable [0]	[0 - 3]	-	UInt8
8-10	Control Word Profile	FC profile [0]	[0 - x]	-	UInt8
8-50	Coasting Select	*Logic OR [3]	[0 - 3]	-	UInt8
8-51	Quick Stop Select	*Logic OR [3]	[0 - 3]	-	UInt8
8-52	DC Brake Select	*Logic OR [3]	[0 - 3]	-	UInt8
8-53	Start Select	*Logic OR [3]	[0 - 3]	-	UInt8
8-54	Reversing Select	*Logic OR [3]	[0 - 3]	-	UInt8
8-55	Set-up Select	*Logic OR [3]	[0 - 3]	-	UInt8
8-56	Preset Reference Select	*Logic OR [3]	[0 - 3]	-	UInt8
8-90	Bus Jog 1 Speed	100 rpm	0 - par. 4-13	67	UInt16
8-91	Bus Jog 2 Speed	200 rpm	0 - par. 4-13	67	UInt16
9-15	PCD Write Configuration	-	-	-	UInt16
9-16	PCD Read Configuration	-	-	-	UInt16
9-18	Node Address	126	1 - 126	0	UInt8
9-22	Telegram Selection	-	[0 - 108]	-	UInt8
9-23	Parameter for Signals	-	0 - 573	-	UInt16
9-27	Parameter Edit	Enabled [1]	[0 - 1]	-	UInt16
9-28	Process Control	Enable cyclic master [1]	[0 - 1]	-	UInt16
9-44	Fault Message Counter	0	[0 - 8]	0	UInt16
9-45	Fault Code	0	-	-	UInt16
9-47	Fault Number	0	-	-	UInt16
9-52	Fault Situation Counter	0	0 - 1000	0	UInt16
9-53	Profibus Warning word	0	16 bits	0	V2
9-63	Actual Baud Rate	No baud rate found [255]	9.6-12000 kbits	0	UInt8
9-64	Device Identification	0	[0 - 10]	0	UInt16
9-65	Profile Number	0	8 bits	0	UInt8
9-70	Edit Set-up	Active set-up [9]	[0 - 9]	-	UInt8
9-71	Save Data Values	Off [0]	[0 - 2]	-	UInt8
9-72	Drive Reset	No action [0]	[0 - 2]	-	UInt8
9-80	Defined Parameters (1)	-	0-115	0	UInt16
9-81	Defined Parameters (2)	-	0-115	0	UInt16
9-82	Defined Parameters (3)	-	0-115	0	UInt16
9-83	Defined Parameters (4)	-	0-115	0	UInt16
9-90	Changed Parameters (1)	-	0-115	0	UInt16
9-91	Changed Parameters (2)	-	0-115	0	UInt16
9-92	Changed Parameters (3)	-	0-115	0	UInt16
9-93	Changed Parameters (4)	-	0-115	0	UInt16
16-84	Comm. Option STW	0	0 - FFFF	0	V2
16-90	Alarm Word	0	0 - FFFF	0	UInt32
16-92	Warning Word	0	0 - FFFF	0	UInt32

Please refer to the relevant Operating Instructions for a comprehensive parameter list.



6.4. Object and Data Types Supported

6.4.1. Parameter and Data Type Structure Description

6.4.2. Parameter Description

PROFIBUS DP has a number of describing attributes. Read/write on parameter description is performed in the PCV part using the RC commands 4/5 and the sub-index of the desired description element.

6.4.3. Size Attribute

The size index and the conversion index for each parameter can be taken from the parameter list in the respective Operating Instructions.

Physical unit	Size index	Measuring unit	Designation	Conversion index	Conversion factor
	0	No dimension			
Time	4	second	s	0	1
				-1	0.1
				-2	0.01
		millisecond	ms	-3	0.001
		minute	min	70	60
		hour	h	74	3600
		day	d	77	86400
Energy	8	watthour	Wh	0	1
		kilowatthour	kWh	3	1000
		megawatthour	MWh	6	10 ⁶
Power	9	milliwatt	mW	-3	0.001
		watt	W	0	1
		kilowatt	kW	3	1000
		megawatt	MW	6	10 ⁶
Rotation	11	rotation per minute	RPM	67	1
Torque	16	newtonmeter	Nm	0	1
		kilonewtonmeter	kNm	3	1000
Temperature	17	degree Celsius	°C	0	1
Voltage	21	millivolt	mV	-3	0.001
		volt	V	0	1
		kilovolt	kV	3	1000
Current	22	milliampere	mA	-3	0.001
		ampere	A	0	1
		kiloampere	kA	3	1000
Resistance	23	milliohm	mOhm	-3	0.001
		ohm	Ohm	0	1
		kiloohm	kOhm	3	1000
Ratio	24	per cent	%	0	1
Relative change	27	per cent	%	0	1
Frequency	28	hertz	Hz	0	1
		kilohertz	kHz	3	1000
		megahertz	MHz	6	10 ⁶
		gigahertz	GHz	9	10 ⁹



6.4.4. Object and Data Types Supported

Data types supported

Data type	Short name	Description
3	I2	Integer 16
4	I4	Integer 32
5	-	Unsigned 8
6	O2	Unsigned 16
7	O4	Unsigned 32
9	-	Visible string
10	-	Byte string
33	N2	Standardized value (16 bit)
35	V2	Bit sequence
54	-	Time difference without date indication

6 6.4.5. Standardized Value

The frequency reference value is transmitted to the frequency converter in the form of a 16-bit word. The value is transmitted in integers (0-32767). The value 16384 (4000 Hex) corresponds to 100%. Negative numbers are formed with the aid of the twos complement.

0% = 0 (0h), 100% is 2^{14} (4000h)

Data type	N2
Range	-200%...+200%
Resolution	$2^{-14} = 0.0061\%$
Length	2 bytes

Notation: 2s complement notation.

MSB is 1st bit after sign bit in 1st byte.

Sign bit = 0 = positive number

Sign bit = 1 = negative number

Bit	8	7	6	5	4	3	2	1
Byte 1	SIGN	2^{14}	2^{13}	2^{12}	2^{11}	2^{10}	2^9	2
Byte 2	2^7	2^6	2^5	24	2^3	2^2	2^1	2^0

Bit sequence

16 boolean values for control and presentation of user functions.

Notation is binary

Bit	8	7	6	5	4	3	2	1
Byte 1	15	14	13	12	11	10	9	8
Byte 2	7	6	5	4	3	2	1	0



7. Application Examples

7.1. E.g.: Process Data with PPO Type 6

This example shows how to work with PPO type 6, which consists of Control Word/Status Word and Reference/Main Actual Value. The PPO also has two additional words, which can be programmed to monitor process signals:

PCV								PCD																								
PCA	IND	PVA			1	2	3	4	5	6	7	8	9	10	11	12	13	14	15	16	17	18	19	20	21	22	23	24	25	26	27	28
					CTW	MRV	PCD	PCD	PCD	PCD	PCD	PCD	PCD	PCD	PCD																	
Byte no.	1	2	3	4	5	6	7	8	9	10	11	12	13	14	15	16	17	18	19	20	21	22	23	24	25	26	27	28				
Type 6:									STW	MAV																						

The application requires monitoring of the motor torque and digital input, so PCD 3 is set up to read the current motor torque. PCD 4 is set up to monitor the state of an external sensor via the process signal digital input. The sensor is connected to digital input 18.

An external device is also controlled via control word bit 11 and the built-in relay of the frequency converter. Reversing is permitted only when the reversing bit 15 in the control word and the digital input 19 are set to high.

For safety reasons the frequency converter will stop the motor if the PROFIBUS cable is broken, the master has a SYSTEM failure, or the PLC is in stop mode.

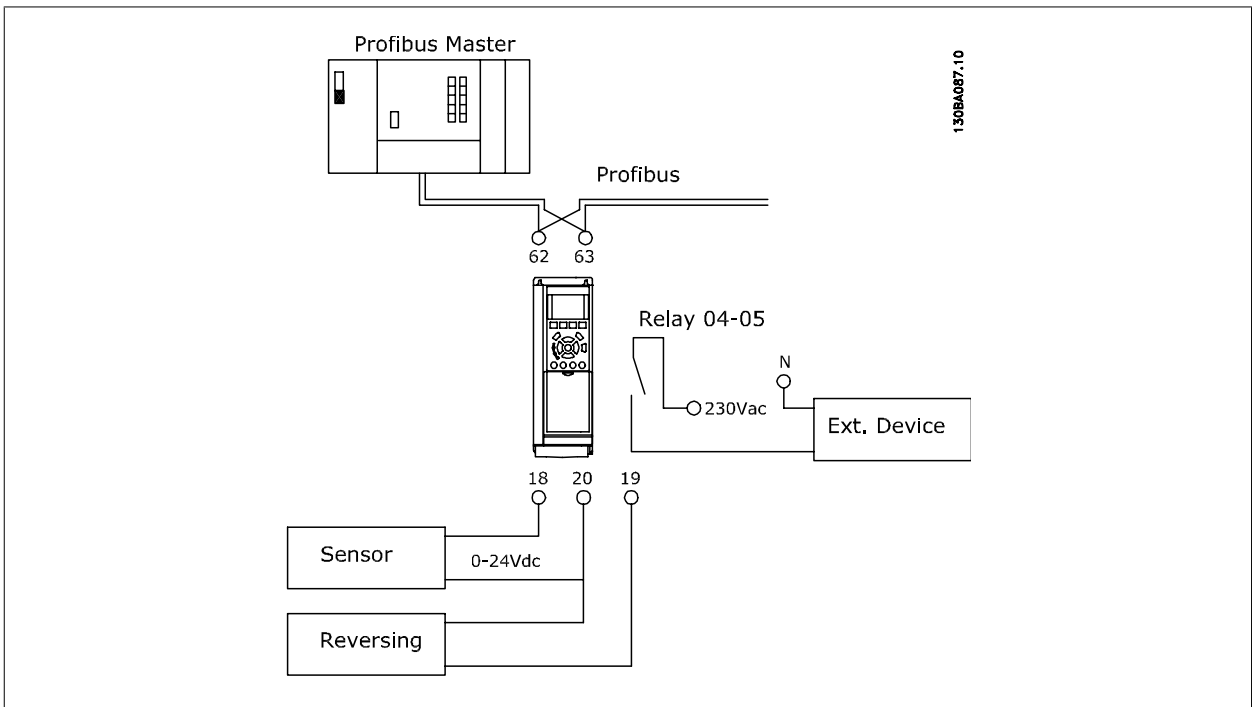

Program the frequency converter as follows:



Parameter no.	Function	Setting
4-10	Output speed direction	Both directions [2]
5-10	Digital input 18	No operation [0]
5-11	Digital input 19	Reversing [10]
5-40	Function relay	Control word bit 11/12 [36/37]
8-03	Control word timeout time	1 sec
8-04	Control word timeout function	Stop [2]
8-10	Control word profile	FC Profile [0]
8-50	Coasting select	Bus [1]
8-51	Quick stop select	Bus [1]
8-52	DC brake select	Bus [1]
8-53	Start select	Bus [1]
8-54	Reversing select	Logic AND [2]
8-55	Set-up select	Bus [1]
8-56	Preset reference select	Bus [1]
9-16	PCD read configuration	Sub index [2] 16-16 Motor torque Sub index [3] 16-60 Digital input
9-18	Node address	Set the address



7.2. E.g.: Control Word Telegram using PPO Type

This example shows how the control word telegram relates to the PLC and the frequency converter, using FC Control Profile.

The control word telegram is sent from the PLC to the frequency converter. PPO Type 3 is used in the example in order to demonstrate the full range of modules. All the values shown are arbitrary, and are provided for the purposes of demonstration only.

PCV										PCD						
PCA		IND		PVA		CTW		MRV		PCD		PCD		PCD		
						04 7C		20 00								
PQW:	256	258	260	262	264	266	268	270	272	274						
master						CTW		MRV								
Bit no.:	15	14	13	12	11	10	9	8	7	6	5	4	3	2	1	0
	0	0	0	0	0	1	0	0	0	1	1	1	1	1	0	0
	0				4				7				C			

The table above indicates the bits contained within the control word, and how they are presented as process data in PPO type 3 for this example.

The following table indicates which bit functions, and which corresponding bit values are active for this example.

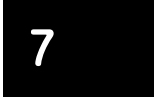

Bit	Bit value = 0	Bit value = 1	Bit value		
00	Reference value	External selection lsb	0	C	
01	Reference value	External selection msb	0		
02	DC brake	Ramp	1		
03	Coasting	Enable	1		
04	Quick stop	Ramp	1	7	
05	Freeze output	Ramp enable	1		
06	Ramp stop	Start	1		
07	No function	Reset	0		
08	No function	Jog	0	4	
09	Ramp 1	Ramp 2	0		
10	Data not valid	Valid	1		
11	No function	Relay 01 active	0		
12	No function	Relay 02 active	0	0	
13	Parameter set-up	Selection lsb	0		
14	Parameter set-up	Selection msb	0		
15	No function	Reversing	0		
Function active					
Function inactive					



7.3. E.g.: Status Word Telegram using PPO Type

This example shows how the control word telegram relates to the PLC and the frequency converter, using FC Control Profile.

The control word telegram is sent from the PLC to the frequency converter. PPO Type 3 is used in the example in order to demonstrate the full range of modules. All the values shown are arbitrary, and are provided for the purposes of demonstration only.

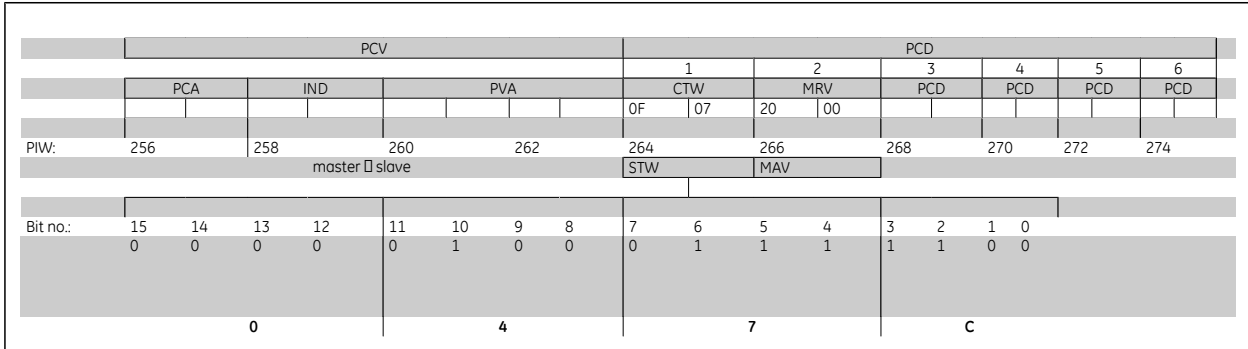

7

The table above indicates the bits contained within the statusword, and how they are presented as process data in PPO type 3 for this example.

The following table indicates which bit functions, and which corresponding bit values are active for this example.

Bit	Bit value = 0	Bit value = 1	Bit value	
00	Control not ready	Control ready	1	7
01	Drive not ready	Drive ready	1	
02	Coasting	Enable	1	
03	No error	Trip	0	
04	No error	Error (no trip)	0	0
05	Reserved	-	0	
06	No error	Triplock	0	
07	No warning	Warning	0	
08	Speed ≠ reference	Speed = reference	1	F
09	Local operation	Bus control	1	
10	Outside frequency range	Within frequency range	1	
11	No operation	In operation	1	0
12	Drive ok	Stopped, autostart	0	
13	Voltage ok	Voltage exceeded	0	
14	Torque ok	Torque exceeded	0	
15	Timers ok	Timers exceeded	0	
Function active		<input type="checkbox"/>		
Function inactive		<input type="checkbox"/>		



7.4. E.g.: PLC Programming

In this example PPO type 6 is placed in the following Input/Output address:

Slot	DP ID	Order Number / Designation	I Address	Q Address	Comment
1	115	PPO Type 6 Word consistent PCD	256...263	256...263	
2					

130ba111

Input address	256-257	258-259	260-261	262-263	Output address	256-257	258-259	260-261	262-263
Set-up	Status word	MAV	Motor torque	Digital input	Set-up	Control word	Reference	Not used	Not used

This network will send a start command (047C Hex) and a reference (2000 Hex) of 50% to the frequency converter.

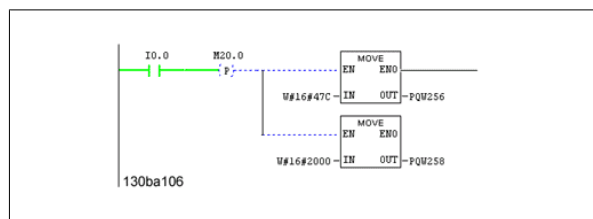

7

This network reads the motor torque from the frequency converter. A new reference will be sent to the frequency converter because the Motor Torque (86.0%) is higher than the compared value.

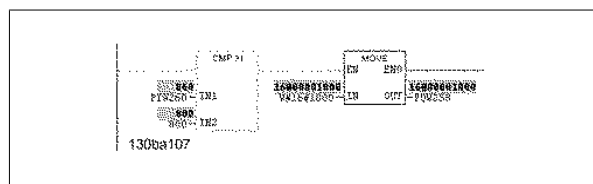



This network reads the status on the digital inputs from the frequency converter. If digital input 18 is On it will stop the frequency converter.

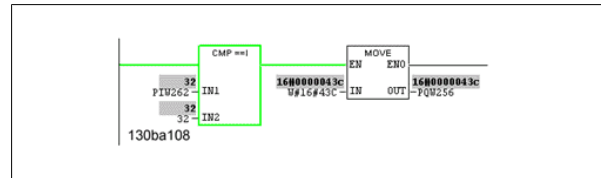

This network will reverse the motor when digital input 19 is ON, because par. 8-54 *Reversing select* is programmed to Logic AND.

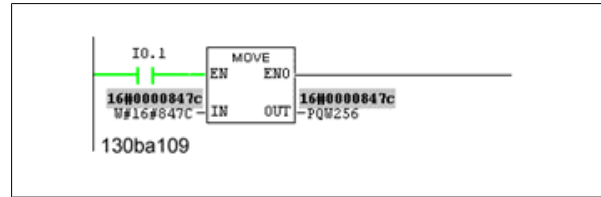

This network will activate the relay 02.

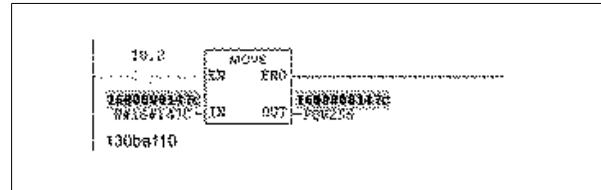

8. Troubleshooting

8.1. Diagnosis

PROFIBUS-DP provides a flexible means of performing diagnosis of slave units, based on diagnosis messages.

During normal cyclical data exchange, the slave can set a diagnosis bit, which requests the master to send a diagnosis message during the next scan cycle, instead of the normal data exchange.

The slave then answers the master with a diagnosis message consisting of standard diagnosis information, 6 bytes, and possibly extended, vendor specific, diagnosis information. The standard diagnosis messages covers a rather limited range of general diagnosis possibilities, whereas the extended diagnosis function offers very detailed messaging specific to the frequency converter.

The extended diagnosis messages for the frequency converter can be found in the section *Warning word, extended status word and alarm word*. A master or a network analysing tool will be able to translate these diagnosis words into real text messages using the GSD-file.



NB!

DP V1 diagnosis is supported for Profibus SW version 2 and later versions. This means that the default setting of the Profibus option is DP V1 diagnosis. If DP V0 diagnosis is required, the setting under *DP slave Properties* must be changed.

8.2. Troubleshooting

8

8.2.1. LED Status

First, check the LEDs. The two bi-colour LEDs on the PROFIBUS card indicate the status of PROFIBUS communication. The lower LED indicates the Net status, i.e. the cyclical communication to the PROFIBUS master. The upper LED indicates the Module status, i.e. acyclical DP V1 communication from either a PROFIBUS Master Class 1 (PLC) or a Master Class 2 (MCT10, FDT tool).

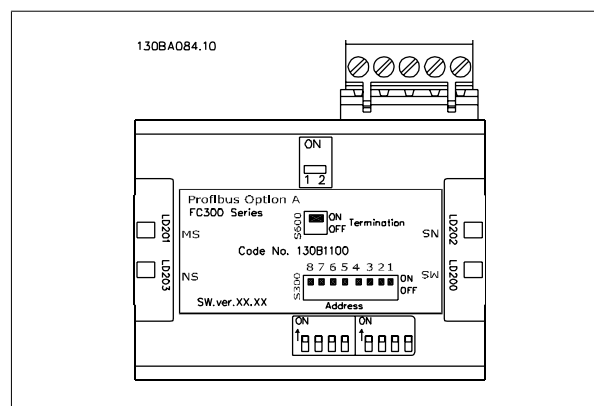









Phases	Bi-colour LED	Status
Power On	Red 	The PROFIBUS card is defect. Contact Danfoss Drives
	Green 	The PROFIBUS card is OK.
Search baud rate	Green 	Searching for the baud rate. Check the connection to the master if it stays in this state.
Wait Parameterizing	Green 	Baud rate found - waiting for parameters from the master.
	Red 	Wrong parameters from the master.
Wait Configuration	Green 	Parameters from master OK - waiting for configuration data.
	Red 	Wrong Configuration data from the master.
Data Exchange	Green 	Data Exchange between the master and the frequency converter is active.
	Red 	Clear State. Warning 34 is active and a bus reaction in par. 8-04 is executed.

Table 8.1: LED 1: Net Status



Bi-colour LED	Status
No light	No PROFIBUS DPV1 communication is active.
Green 	DP V1 communication from a Master Class 1 (PLC) is active.
Green 	DP V1 communication from a Master Class 2 (MCT 10, FDT) is active.
Green 	DP V1 communication from a Master Class 1 and 2 is active.
Red 	Internal error.

Table 8.2: LED 2: Module Status

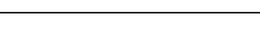
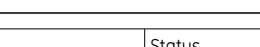
8

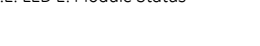

8.2.2. No Communication with the Drive

If there is no communication with the drive, proceed with the following checks:

Check 1: Is the cabling correct?

Check that the red and green cables are connected to the correct terminals as shown in the diagram below. If the cables are crossed, no communication is possible.

- 62 = RxD/TxD-P red cable
- 63 = RxD/TxD-N green cable

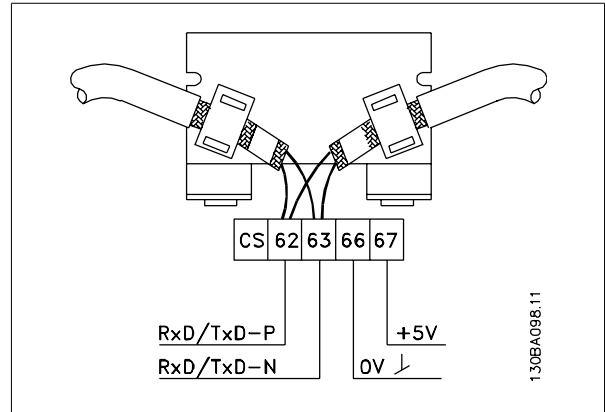

Check 2: Is the correct GSD file installed?

Download the correct GSD file from <http://danfoss.com/drives>.

Profibus SW version (par. 15-61)	GSD File
1.x	da01040A.GSD
2.x	da02040A.GSD

8

Check 3: Is the bus connection terminated at both ends?

If not, terminate the bus connection with termination resistors at the initial and final nodes, as shown in the following diagram.

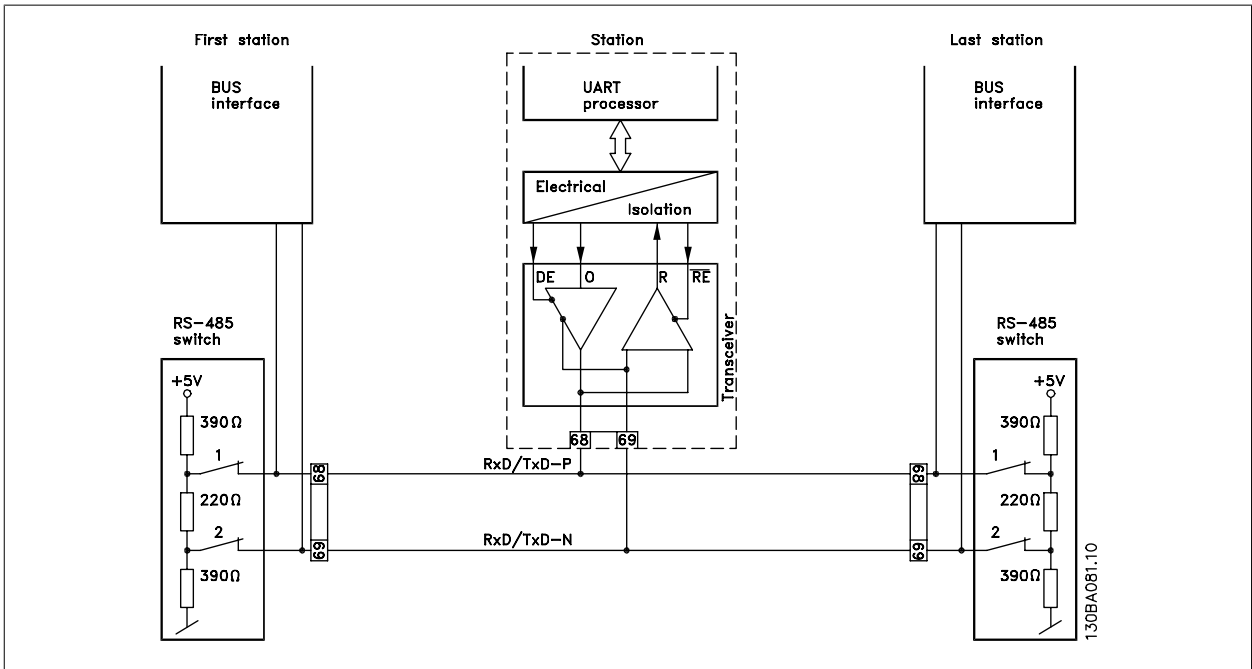



8.2.3. Warning 34 Appears even though Communication is Established

If the PLC is in stop mode Warning 34 will appear. Check that the PLC is in run mode.

8.2.4. Drive Will Not Respond to Control Signals

Check 1: Is the Control word valid?

If bit 10=0 in the Control word, then the drive will not accept the Control word, because the default setting is bit 10=1. Set bit 10=1 via the PLC.

Check 2: Is the relationship between bits in the Control word and the terminal I/Os correct?

Check the logical relationship in the drive.

Set the logic to bit 3=1 AND digital input=1 in order to achieve a successful start.

Define the desired logical relationship in par. 8-50 to 8-56 according to the following range of options. Select the FC control mode, digital input and/or serial communication, using par. 8-50 to 8-56.

The tables below show the effect upon the frequency converter of a coast command for the full range of par. 8-50 settings.

The effect of control mode upon the function of par. 8-50 *Coasting select*, 8-51 *Quick stop select* and 8-52 *DC Brake select* is as follows:

If *Digital input [0]* is selected, the terminals will control the Coast and DC Brake functions.

Digital input [0]		
Terminal	Bit 02/03/04	Function
0	0	Coast/DC brake/Q-Stop
0	1	Coast/DC brake/Q-Stop
1	0	No Coast/DC brake/Q-Stop
1	1	No Coast/DC brake/Q-Stop

8



NB!

Please note that Coasting, Quick Stop and DC brake functions are active for logic "0".

If *Serial communication [1]* is selected, commands will be activated only when given via serial communication.

Serial communication [1]		
Terminal	Bit 02/03/04	Function
0	0	Coast/DC brake/Q-Stop
0	1	No Coast/DC brake/Q-Stop
1	0	Coast/DC brake/Q-Stop
1	1	No Coast/DC brake/Q-Stop

If *Logic AND [2]* is selected, both signals must be activated to perform the function.

Logic AND [2]		
Terminal	Bit 02/03/04	Function
0	0	Coast/DC brake/Q-Stop
0	1	No Coast/DC brake/Q-Stop
1	0	No Coast/DC brake/Q-Stop
1	1	No Coast/DC brake/Q-Stop



If Logic OR [3] is selected, activation of one signal will activate the function.

Logic OR [3]		
Terminal	Bit 02/03/04	Function
0	0	Coast/DC brake/Q-Stop
0	1	Coast/DC brake/Q-Stop
1	0	Coast/DC brake/Q-Stop
1	1	No Coast/DC brake/Q-Stop

The effect of control mode upon the function of par. 8-53 *Start select* and 8-54 *Reversing select*:

If *Digital input* [0] is selected, the terminals will control the start and reversing functions

Digital input [0]		
Terminal	Bit 06/15	Function
0	0	Stop/Anti-clockwise
0	1	Stop/Anti-clockwise
1	0	Start/Clockwise
1	1	Start/Clockwise

If *Serial communication* [1] is selected, commands will be activated only when given via serial communication.

Serial communication [1]		
Terminal	Bit 02/03/04	Function
0	0	Stop/Anti-clockwise
0	1	Start/Clockwise
1	0	Stop/Anti-clockwise
1	1	Start/Clockwise

If *Logic AND* [2] is selected, both signals must be activated to perform the function.

Logic AND [2]		
Terminal	Bit 02/03/04	Function
0	0	Stop/Anti-clockwise
0	1	Stop/Anti-clockwise
1	0	Stop/Anti-clockwise
1	1	Start/Clockwise

If *Logic OR* [3] is selected, activation of one signal will activate the function.

Logic OR [3]		
Terminal	Bit 02/03/04	Function
0	0	Stop/Anti-clockwise
0	1	Start/Clockwise
1	0	Start/Clockwise
1	1	Start/Clockwise

The effect of control mode upon the function of par. 8-55 *Set-up select* and 8-56 *Preset reference select*:

If *Digital input* [0] is selected, the terminals will control the set-up and preset reference functions.

Digital input [0]				
Terminal		Bit 00/01, 13/14		Function
Msb	Lsb	Msb	Lsb	Preset ref., Set-up no.
0	0	0	0	1
0	0	0	1	1
0	0	1	0	1
0	0	1	1	1
0	1	0	0	2
0	1	0	1	2
0	1	1	0	2
0	1	1	1	2
1	0	0	0	3
1	0	0	1	3
1	0	1	0	3
1	0	1	1	3
1	1	0	0	4
1	1	0	1	4
1	1	1	0	4
1	1	1	1	4



If *Serial communication* [1] is selected, commands will be activated only when given via serial communication.

<i>Serial communication</i> [1]				
Terminal		Bit 00/01, 13/14		Function
Msb	Lsb	Msb	Lsb	Preset ref., Set-up no.
0	0	0	0	1
0	0	0	1	2
0	0	1	0	3
0	0	1	1	4
0	1	0	0	1
0	1	0	1	2
0	1	1	0	3
0	1	1	1	4
1	0	0	0	1
1	0	0	1	2
1	0	1	0	3
1	0	1	1	4
1	1	0	0	1
1	1	0	1	2
1	1	1	0	3
1	1	1	1	4

If *Logic AND* [2] is selected, both signals must be activated to perform the function.

<i>Logic AND</i> [2]				
Terminal		Bit 00/01, 13/14		Function
Msb	Lsb	Msb	Lsb	Preset ref., Set-up no.
0	0	0	0	1
0	0	0	1	1
0	0	1	0	1
0	0	1	1	1
0	1	0	0	1
0	1	0	1	2
0	1	1	0	1
0	1	1	1	2
1	0	0	0	1
1	0	0	1	1
1	0	1	0	3
1	0	1	1	3
1	1	0	0	1
1	1	0	1	2
1	1	1	0	3
1	1	1	1	4

If *Logic OR* [3] is selected, activation of one signal will activate the function.

<i>Logic OR</i> [3]				
Terminal		Bit 00/01, 13/14		Function
Msb	Lsb	Msb	Lsb	Preset ref., Set-up no.
0	0	0	0	1
0	0	0	1	2
0	0	1	0	3
0	0	1	1	4
0	1	0	0	2
0	1	0	1	2
0	1	1	0	4
0	1	1	1	4
1	0	0	0	3
1	0	0	1	4
1	0	1	0	3
1	0	1	1	4
1	1	0	0	4
1	1	0	1	4
1	1	1	0	4

8



8.2.5. Alarm and Warning Words

Alarm word, Warning word and PROFIBUS warning word are shown on the display in Hex format. If there is more than one warning or alarm, a sum of all warnings or alarms will be shown. Alarm word, warning word and PROFIBUS warning word can also be displayed using the serial bus in par. 16-90, 16-92 and 9-53.

FC 100, 200 and 300			
Bit (Hex)	Unit diag-nose bit	Alarm word (Par. 16-90)	Alarm no.
00000001	48	Brake check	28
00000002	49	Power card over temperature	29
00000004	50	Earth fault	14
00000008	51	Control card over temperature	65
00000010	52	Control word timeout	18
00000020	53	Over current	13
00000040	54	Torque limit	12
00000080	55	Motor thermistor over temp.	11
00000100	40	Motor ETR over temperature	10
00000200	41	Inverter overloaded	9
00000400	42	DC link under voltage	8
00000800	43	DC link over voltage	7
00001000	44	Short circuit	16
00002000	45	Inrush fault	33
00004000	46	Mains phase loss	4
00008000	47	AMA not OK	50
00010000	32	Live zero error	2
00020000	33	Internal fault	38
00040000	34	Brake overload	26
00080000	35	Motor phase U is missing	30
00100000	36	Motor phase V is missing	31
00200000	37	Motor phase W is missing	32
00400000	38	Fieldbus comm. fault	34
00800000	39	24 V supply fault	47
01000000	24	Mains failure	36
02000000	25	1.8 V supply fault	48
04000000	26	Brake resistor short circuit	25
08000000	27	Brake chopper fault	27
10000000	28	Option change	67
20000000	29	Drive initialisation	80
40000000	30	Safe stop	68
80000000	31	Mechanical brake low	63

FC 100, 200 and 300			
Bit (Hex)	Unit diag-nose bit	Warning word (Par. 16-92)	Alarm no.
00000001	112	Brake check	28
00000002	113	Power card over temperature	29
00000004	114	Earth fault	14
00000008	115	Control card	65
00000010	116	Control word timeout	18
00000020	117	Over current	13
00000040	118	Torque limit	12
00000080	119	Motor thermistor over temp.	11
00000100	104	Motor ETR over temperature	10
00000200	105	Inverter overloaded	9
00000400	106	DC link under voltage	8
00000800	107	DC link over voltage	7
00001000	108	DC link voltage low	6
00002000	109	DC link voltage high	5
00004000	110	Mains phase loss	4
00008000	111	No motor	3
00010000	96	Live zero error	2
00020000	97	10 V low	1
00040000	98	Brake overload	26
00080000	99	Brake resistor short circuit	25
00100000	100	Brake chopper fault	27
00200000	101	Speed limit	49
00400000	102	Fieldbus comm. fault	34
00800000	103	24 V supply fault	47
01000000	88	Mains failure	36
02000000	89	Current limit	59
04000000	90	Low temperature	66
08000000	91	Voltage limit	64
10000000	92	Encoder loss	61
20000000	93	Output frequency limit	62
40000000	94	Unused	-
80000000	95	Warning word 2 (ext. stat. word)	-

FC 100, 200 and 300		
Bit (Hex)	Unit diag-nose bit	PROFIBUS warning word (Par. 9-53)
00000001	160	Connection with DP-master is not ok
00000002	161	Unused
00000004	162	FDL (Field-bus Data link Layer) is not ok
00000008	163	Clear data command received
00000010	164	Actual value is not updated
00000020	165	Baudrate search
00000040	166	PROFIBUS ASIC is not transmitting
00000080	167	Initialising of PROFIBUS is not ok
00000100	152	Drive is tripped
00000200	153	Internal CAN error
00000400	154	Wrong configuration data from PLC
00000800	155	Wrong ID sent by PLC
00001000	156	Internal error occurred
00002000	157	Not configured
00004000	158	Timeout active
00008000	159	Warning 34 active



FC 100, 200 and 300	
Bit (Hex)	Comm. option STW (Par. 16-84)
00000001	parameterization ok
00000002	configuration ok
00000004	clearmode active
00000008	baudrate search
00000010	waiting for parameterization
00000020	waiting for configuration
00000040	in data exchange
00000080	not used
00000100	not used
00000200	not used
00000400	not used
00000800	MCL2/1 connected
00001000	MCL2/2 connected
00002000	MCL2/3 connected
00004000	data transport active
00008000	not used

**NB!**

Par. 16-84 *Comm. Option STW* is not part of extended diagnosis.

8.2.6. Warning and Alarm Messages

There is a clear distinction between alarms and warnings. When there is an alarm, the frequency converter will enter a fault condition. After the cause for the alarm has been cleared, the master will have to acknowledge the alarm message before the frequency converter can start operating again. A warning, on the other hand, may come when a warning condition appears, then disappear when conditions return to normal, without interfering with the process.

Warnings

Warnings within the frequency converter are represented by a single bit within a warning word. A warning word is always an active parameter. Bit status FALSE [0] means no warning, while bit status TRUE [1] means warning. Any bit change in the warning word will be notified by a change of bit 7 in the status word.



Alarms

Following an alarm message the frequency converter will enter Fault condition. Only after the fault has been alleviated and the master has acknowledged the alarm message by setting bit 7 in the control word, can the frequency converter resume operation. Alarms within the frequency converter are represented by a single bit within an alarm word. An alarm word is always an action parameter. Bit status FALSE [0] means no fault, while bit status TRUE [1] means fault.

8.2.7. Fault Messages via DP Diagnosis

The standard DP function features an on-line diagnosis, which is active during DP initialisation as well as data exchange mode.



8.2.8. Extended Diagnosis

Using the extended diagnosis function, alarm and warning information can be received from the frequency converter. The setting of par. 8-07 *Diagnosis trigger* determines which frequency converter events should trigger the extended diagnosis function.

When par. 8-07 *Diagnosis trigger* is set to Disable [0], no extended diagnosis data are sent regardless of whether they appear in the frequency converter.

When par. 8-07 *Diagnosis trigger* is set to Alarms [1], extended diagnosis data are sent when one or more alarms arrive in the alarm par. 16-90 *Alarm word* or 9-53 *Warning word*.

When par. 8-06 is set to Alarms/Warnings [2], extended diagnosis data are sent if one or more alarms/warnings arrive in the alarm par. 16-90 *Alarm word* or 9-53 *Warning word*, or in the warning par. 16-92 *Warning word*.

The extended diagnosis sequence is as follows: If an alarm or warning appears, the frequency converter will indicate that to the master by sending a high priority message via the output data telegram. This will cause the master to send a request for extended diagnosis information to the frequency converter, to which the frequency converter will reply. When the alarm or warning disappears, the frequency converter will again indicate that to the master, and on the following request from the master, return a standard DP diagnosis frame (6 bytes).

The content of the extended diagnosis frame is as follows:

Byte	Bit no.	Name
0 to 5		Standard DP Diagnosis data
6		PDU length
7	0-7	Status type =0x81
8	8-15	Slot = 0
9	16-23	Status Information
10	24-31	Frequency converter alarm word (par. 16-90)
11	32-39	Frequency converter alarm word (par. 16-90)
12	40-47	Frequency converter alarm word (par. 16-90)
13	48-55	Frequency converter alarm word (par. 16-90)
14	56-63	Reserved for future use
15	64-71	Reserved for future use
16	72-79	Reserved for future use
17	80-87	Reserved for future use
18	88-95	Frequency converter warning word (par. 16-92)
19	96-103	Frequency converter warning word (par. 16-92)
20	104-111	Frequency converter warning word (par. 16-92)
21	112-119	Frequency converter warning word (par. 16-92)
22	120-127	Reserved for future use
23	128-135	Reserved for future use
24	136-143	Reserved for future use
25	144-151	Reserved for future use
26	152-159	PROFIBUS warning word (par. 9-53)
27	160-167	PROFIBUS warning word (par. 9-53)
28	168-175	Reserved for future use
29	176-183	Reserved for future use
30	184-191	Reserved for future use
31	192-199	Reserved for future use



Index

A

Abbreviations	9
Alarm Word	87
Axis	49

B

Bus Jog 2 Speed	65
Bus Topology	7

C

Cable Lengths And Number Of Codes	11
Cable Routing	13
Complete Description	51
Connecting The Bus Line	14
Connection Of The Cable Screen	12
Control Profile	30
Control Word According To Fc Profile (ctw)	36
Control Word According To Profdrive Profile (ctw)	30
Control Word Timeout Function	62

D

Data Exchange By Profibus Dp V1	45
Data Store	43
Data Types Supported	74
Diagnosis	81
Dp V1 Features For Parameter Access	46
Dp V1 Read / Write Services	46
Drive Will Not Respond To Control Signals	84

E

Earth Connection	13
Emc Precautions	12
Error Number For Drive Profile V3.0	53
Extended Diagnosis	90

F

Fault Messages Via Dp Diagnosis	89
Field Pcd Normalization	51
Freeze/unfreeze	41

G

Gsd File	18
----------	----

I

Id Extension	51
Identifier Id	50
Influence Of The Digital Input Terminals Upon Fc Control Mode, Par. 8-50 To 8-56	29

L

Led Status	81
Leds	23
Lower Limit	51

M

Master Class 1 Connection	44
Master Class 2 Connection	45
Mct 10 Pc Software Tool	5
Mrv	57

**N**

Name	51
No Communication With The Drive	83
Number Of Array Elements	50
Number Of Parameters	49

P

Parameter Access	43
Pca - Parameter Characteristics	55
Pca Handling	55
Pcd	57
Pcd Reference Parameter	51
Pcv	57
Pcv Parameter Access	55
Ppo Types	25
Process Control Data	27
Process Control Operation	29
Process Data	27
Process Status Data	27
Profibus Warning Word	69
Profidrive State - Transition Diagram	34

Q

Quick Stop Select	63
-------------------	----

R

Rc Content	56
Read / Write In Double Word Format	44
Reference Handling	27
Request / Response Attributes	49
Request / Response Handling	56
Request Id	49
Reset Control Word Timeout	62
Response Id	49

S

Safety Note	4
Services Overview For Fc 100, 200 And 300	45
Setting The Profibus Address	17
Size Attribute	73
Status Word According To Profidrive Profile (stw)	33
Sync/unsync	41

U

Upper Limit	51
-------------	----

V

Value	53
Variable Attribute	51
Vlt Parameters	23

W

Warning 34	84
Warning Word	87

The instructions do not purport to cover all details or variations in equipment nor to provide for every possible contingency to be met in connection with installation, operation or maintenance. Should further information be desired or should particular problems arise which are not covered sufficiently for the purchaser's purposes, the matter should be referred to the GE company.

AF-650 GP and AF-600 FP are trademarks of the General Electric Company.

GE Consumer & Industrial
41 Woodford Avenue
Plainville, CT 06062

www.geelectrical.com/drives



imagination at work

130R0137

MG11X102



* M G 1 1 X 1 0 2 *

DET-624