

GE

AF-650 GP™ & AF-600 FP™ Profibus DP

Instruction Manual



a product of
ecomagination





Contents

1 Introduction	1-1
Safety Note	1-1
Technical Overview	1-4
Network Topology	1-4
2 How to Install	2-1
Cabling	2-1
EMC Precautions	2-2
Connecting the Network	2-3
3 How to Configure the System	3-1
Configure the PROFIBUS Network	3-1
Configure the Master	3-2
GSD File	3-2
Configure the Adjustable Frequency Drive	3-4
Drive Parameters	3-4
LEDs	3-5
4 How to Control the Adjustable Frequency Drive	4-1
PPO Types	4-1
Process Data	4-3
Reference Handling	4-3
Process Control Operation	4-5
Control Profile	4-5
PROFIdrive Control Profile	4-5
GE Drive Control Profile	4-11
Synchronize and Freeze	4-15
5 How to Access the Parameters	5-1
Parameter Access in General	5-1
DP V1 Parameter Access	5-2
How to Use the DP V1 Features for Parameter Access	5-4
PCV Parameter Access	5-12
6 Parameters	6-1
PROFIBUS-specific Parameter List	6-11
Object and Data Types Supported	6-12
7 Application Examples	7-1



E.g.: Process Data with PPO Type 6	7-1
E.g.: Control Word Network using PPO Type	7-3
E.g.: Status Word Network using PPO Type	7-4
E.g.: PLC Programming	7-5
8 Troubleshooting	8-1
Diagnostics	8-1
Troubleshooting	8-1
LED Status	8-1
No Communication with the Drive	8-2
Warning 34 Appears even though Communication is Established	8-3
Drive Will Not Respond to Control Signals	8-3
Alarm and Warning Words	8-6
Fault Messages via DP Diagnostics	8-7
Extended Diagnostics	8-7
9 Warnings and Alarms	9-1
Status Messages	9-1
Warnings/Alarm Messages	9-1
Alarm List	9-2
10 Index	10-1



1 Introduction

1

1.1.1 Copyright, Limitation of Liability and Revision Rights

This publication contains information proprietary to GE. By accepting and using this manual the user agrees that the information contained herein will be used solely for operating equipment from GE or equipment from other vendors provided that such equipment is intended for communication with GE equipment over a PROFIBUS serial communication link. This publication is protected under the Copyright laws.

GE does not warrant that a software program produced according to the guidelines provided in this manual will function properly in every physical, hardware or software environment.

Although GE has tested and reviewed the documentation within this manual, GE makes no warranty or representation, either express or implied, with respect to this documentation, including its quality, performance, or fitness for a particular purpose.

In no event shall GE be liable for direct, indirect, special, incidental, or consequential damages arising out of the use, or the inability to use information contained in this manual, even if advised of the possibility of such damages. In particular, GE is not responsible for any costs including but not limited to those incurred as a result of lost profits or revenue, loss or damage of equipment, loss of computer programs, loss of data, the costs to substitute these, or any claims by third parties.

GE reserves the right to revise this publication at any time and to make changes in its contents without prior notice or any obligation to notify previous users of such revisions or changes.

1.2.1 Safety Note



The voltage of the adjustable frequency drive is dangerous whenever connected to line power. Incorrect installation of the motor, adjustable frequency drive or network may cause damage to the equipment, serious personal injury or death. Consequently, the instructions in this manual, as well as national and local rules and safety regulations, must be complied with.

1.2.2 Safety Regulations

1. The adjustable frequency drive must be disconnected from line power if repair work is to be carried out. Make sure that the line power supply has been disconnected and that the necessary time has passed before removing motor and line power plugs.
2. The [OFF] key on the control panel of the adjustable frequency drive does not disconnect the equipment from line power and is thus not to be used as a safety switch.
3. Correct protective grounding of the equipment must be established, the user must be protected against supply voltage, and the motor must be protected against overload in accordance with applicable national and local regulations.
3. Correct protective grounding of the equipment must be established, the user must be protected against supply voltage, and the motor must be protected against overload in accordance with applicable national and local regulations.
4. The ground leakage currents are higher than 3.5 mA.
5. Protection against motor overload is not included in the factory setting. If this function is desired, set F-10 *Electronic Overload* to data value *Electronic Overload trip* or data value *Electronic Overload warning*. Note: The function is initialized at 1.16 x rated motor current and rated motor frequency. For the North American market: The Electronic Overload functions provide class 20 motor overload protection in accordance with NEC.
6. Do not remove the plugs for the motor and line power supply while the adjustable frequency drive is connected to line power. Make sure that the line power supply has been disconnected and that the necessary time has passed before removing motor and line power plugs.
7. Please note that the adjustable frequency drive has more voltage inputs than L1, L2 and L3 when load sharing (linking of DC intermediate circuit) and external 24 V DC have been installed. Make sure that all voltage inputs have been disconnected and that the necessary time has passed before commencing repair work.



1.2.3 Warning Against Unintended Start

1. The motor can be brought to a stop by means of digital commands, network commands, references or a local stop, while the adjustable frequency drive is connected to line power. If personal safety considerations make it necessary to ensure that no unintended start occurs, these stop functions are not sufficient.
2. While parameters are being changed, the motor may start. Consequently, the Off key on the keypad must always be activated; following which data can be modified.
3. A motor that has been stopped may start if faults occur in the electronics of the adjustable frequency drive, or if a temporary overload or a fault in the supply line power or the motor connection ceases.

1.2.4 Warning



Touching the electrical parts may be fatal - even after the equipment has been disconnected from line power.

Also make sure that other voltage inputs have been disconnected, such as an external 24V DC using option module OPC24VPS, load sharing (linkage of DC intermediate circuit), as well as the motor connection for kinetic backup.

Please refer to the AF-650 GP or AF-600 FP Drive Instruction Manual for further safety guidelines.

1.3 About this Manual

First time users can obtain the most essential information for quick installation and set-up in these chapters:

Introduction

How to Install

How to Configure the System

Application Examples

For more detailed information including the full range of set-up options and diagnostics tools please refer to the chapters:

How to Control the Adjustable Frequency Drive

How to Access the Parameters

Parameters

Troubleshooting

1.4 About PROFIBUS

PROFIBUS is standardized in the international standards IEC 61158 and IEC 61784, and supported by the member companies of the PROFIBUS International user community.

PROFIBUS International (PI) is the umbrella organization for all Regional PROFIBUS Associations (RPA) worldwide. PI has engaged PNO (PROFIBUS Nutzerorganisation, e. V.), Germany, a non-profit organization based in Karlsruhe, Germany, to establish technical committees and working groups in order to define and maintain the open and vendor-independent PROFIBUS technology. Any member of PROFIBUS International may take an active part in maintenance and further development of the PROFIBUS technology. This guarantees openness and vendor independence of the PROFIBUS technology.

For access to the vast quantity of PROFIBUS literature including information and downloads for PROFIBUS DP and the PROFIDrive profile, please refer to www.profibus.com.



1.5 About PROFIBUS DP V1

By operating the adjustable frequency drive via a network you can reduce the capital cost of your system, communicate faster and more efficiently, and enjoy an easier user interface.

Using PROFIBUS DP V1 also guarantees you a product which has wide compatibility, a high level of availability and support, and which will be compatible with future versions. 10.

With the DCT 10 Drive Control Tool software, you can control and configure your system simultaneously, and monitor the entire system more effectively for faster diagnostics, and better preventive maintenance. Simplify commissioning, maintenance and documentation using DCT 10 Drive Control Tool software.

Features of PROFIBUS DP V1:

Cost savings

- PROFIBUS DP V1 permits very effective use of PLC I/O capacity, in effect, expanding the volume capacity of your existing PLC by up to two-thirds.

Fast and efficient communication

- short network cycle times
- improved network efficiency

Easy to use

- transparent installation, diagnostics and parameterization

Flexibility and compatibility

- Two different state machines can be selected: PROFIdrive profile or GE Drive profile
- Communication using PROFIBUS DP V1, Master Class 1 and Master Class 2

Future-proof investment

- Downward compatibility: New protocol extensions retain all the functions of the previous versions
- Continuous development of new application-oriented profiles
- Wide product availability
- Intelligent base for future technologies such as OPC, FDT/DTM, PROFINET

Technical features:

- Network timeout reaction
- PLC/CPU stop reaction
- Eight PPO types available
- Numerous relevant process data (PCD) types available
- Automatic detection of baud rate and PPO type
- Extended diagnostics available
- Alarms and warnings available as text messages within the PLC
- Equidistant network cycle time configurable in PLC system
- Improved network efficiency, since the cyclic parameter channel is no longer required
- Very short network cycle times compared to industrial ethernet
- Backwards compatibility with DP



Features of DCT 10 Drive Control Tool software:

- Project-oriented PC tool, one tool for all AF-6 Series Drives
- Links to all Windows applications possible
- Supports Siemens CPs 5511 (PCMCIA) and 5611 (PCI card), for PROFIBUS DP V1 Master Class 2 connection
- Support of standard interfaces: COMx, USB, RS232 (FLUX)
- Siemens PG / Field PGs already have the necessary hardware
- View is highly configurable

1.6 Technical Overview

1.6.1 Network Topology

Single master

- PLC communicates with messages of constant length
- Fits time-critical requirements
- Cyclical transmission via PPO types
- Extended diagnostics

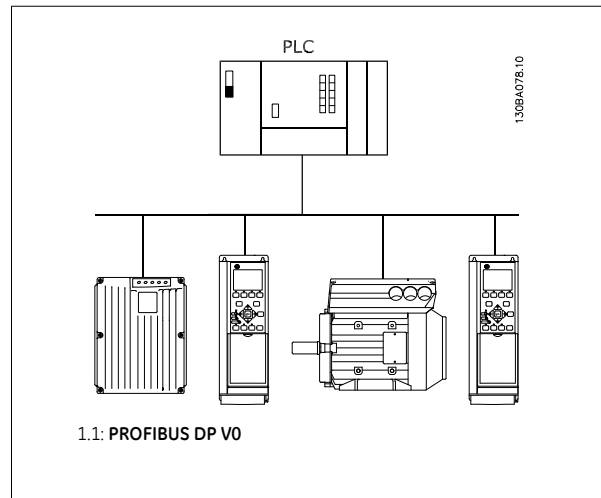



1.6.2 Network Topology

Multiple master

Features of a Master Class 1 connection

- Cyclical data exchange (DP V0)
- Acyclical read/write on parameters
- Extended diagnostics

The acyclical connection is fixed, and cannot be changed during operation.

Features of a Master Class 2 connection:

- Initiate / Abort acyclical connection
- Acyclical read/write on parameters

The acyclical connection can be established (Initiate) or removed (Abort) dynamically even when a Master Class 1 is active on the network. The DP V1 acyclical connection can be used for general parameter access as an alternative to the PCV parameter channel.

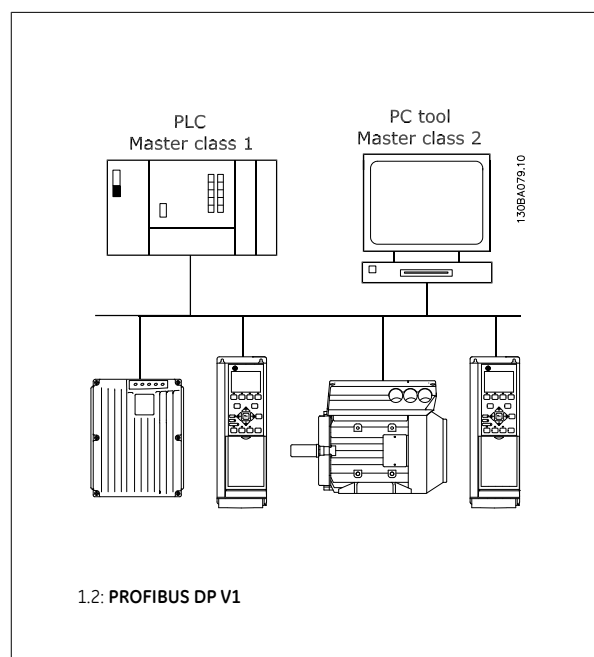

The PROFIBUS DP extension DP V1 permits acyclical as well as cyclical data communication. This feature can be used by a DP Master Class 1 (e.g., PLC), as well as a DP Master Class 2 (e.g., PC tool).

1.7 Assumptions

This manual assumes you are using the AF-6 Series Drives Profibus DP Communications Module in conjunction with an AF-650 GP or AF-600 FP drive. It is also assumed that your master is a PLC or PC equipped with a serial communication card supporting all the PROFIBUS communication services required by your application, and that all requirements stipulated in the PROFIBUS standard, as well as those set up in the PROFIBUS Variable Speed Drive Profile and its company-specific implementation PROFIDrive, as well as those pertaining to the AF-6 Series Drive are strictly observed as well as all limitations therein fully respected.

1.8 Hardware

This Instruction Manual refers to the Profibus network Model No. OPCPDP.

The Profibus Option will be identified as: OPCPDP Profibus DP V1 in ID-60 Option Mounted.

1.9 Background Knowledge

The Profibus DP Communications Module is designed to communicate with any master complying with the PROFIBUS standard. Familiarity with the PC or PLC you intend to use as a master in your system is assumed. Issues regarding hardware or software produced by other manufacturers are beyond the scope of this manual, and are not the responsibility of GE.

If you have questions regarding set-up of master-to-master communication, or communication to a non-GE slave, please consult the appropriate manuals.

1.10 Available Literature

For additional AF-6 Series Drives information please visit www.geelectrical.com/drives.



1

1.11 Abbreviations

ACI	Acyclical Control Interval
AOC	Application Orientated Controller
CAN	Controller Area Network
CTW	Control Word
DP	Distributed Periphery
DU	Data Unit
EEPROM	Electrical Erasable Programmable Read Only Memory
EIA	Electronic Industries Alliance: Specifier of the EIA Standard RS 485-A
EMC	Electromagnetic Compatibility
FDT	Field Device Tool
IND	Sub index
ISO	International Standards Organization
LCD	Liquid Crystal Display
LED	Light Emitting Diode
MAV	Main Actual Value
MC1	Master Class 1
MC2	Master Class 2
MOC	Motion Orientated Controller
MRV	Main Reference Value
NDL	Network Data Link Layer
PB	PROFIBUS
PC	Personal Computer
PCD	Process Data
PCA	Parameter Characteristics
PCV	Parameter-Characteristics-Value
PDU	Protocol Data Unit
PLC	Programmable Logic Control
PNU	Parameter Number
PPO	Parameter-Process Data
PVA	Parameter Value
RC	Request/Response Characteristics
SAP	Service Access Point
SMP	Spontaneous Message
STW	Status Word



2 How to Install

2.1 Cabling

2.1.1 Cable Lengths and Number of Codes

The maximum cable length allowable in one segment is dependent on the transmission speed. The total cable length includes drop cables if any. A drop cable is the connection from the main network cable to each node if a T-connection is used instead of permissible cable length and maximum number of nodes/adjustable frequency drives with 1, 2, 3 and 4 network segments.

Drop cable connection (i.e., T-connection) beyond the cable lengths indicated is not recommended, due to the increased risk of reflection occurring. Instead, GE recommends direct connection of the adjustable frequency drive.

Note that a repeater is a node in both of the two segments it connects. The number of adjustable frequency drives is based on a single master system. If there are two or more masters (e.g., PC tools), the number of adjustable frequency drives must be reduced correspondingly.

Maximum total network cable length:

Transmission speed	1 segment: 32 nodes (31 drives) [m]	2 segments: 64 nodes (1 repeater, 61 drives) [m]	3 segments: 96 nodes (2 repeaters, 91 drives) [m]	4 segments: 128 nodes (3 repeaters, 121 drives) [m]
9.6–187.5 kBaud	1000	2000	3000	4000
500 kBaud	400	800	1200	1600
1.5 Mbaud	200	400	600	800
3–12 Mbaud	100	200	300	400

Total drop cable length limit per segment:

Transmission speed	Max. drop cable length per segment [m]
9.6–93.75 kBaud	96
187.5 kBaud	75
500 kBaud	30
1.5 Mbaud	10
3–12 Mbaud	None

The length statements in the tables above are valid for network cable with the following properties:

- Impedance: 135 to 165 ohm at a measuring frequency from 3 to 20 MHz
- Resistance: <110 ohm/km
- Capacitance: <30 pF/m
- Damping: max. 9 dB over the whole wire length
- Cross-section: max. 0.00053 in² [0.34 mm²], corresponding to AWG 22
- Cable type: twisted in pairs, 1 x 2, or 2 x 2, or 1 x 4 wires
- Shielding: Copper-braided shield or braided shield and foil shield

Use of the same cable type throughout the entire network is recommended to avoid impedance mismatch.



The numbers on the following diagram indicate the maximum number of stations in each segment. They are not the station addresses, as each station in the network must have a unique address.

2

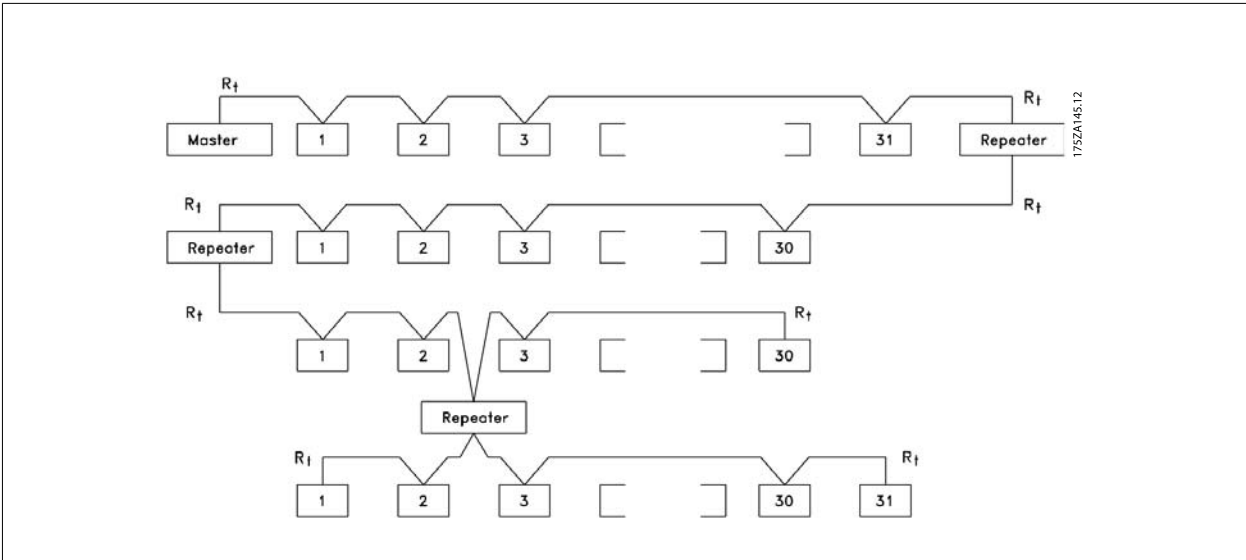

2.1.2 EMC Precautions

The following EMC precautions are recommended to achieve interference-free operation of the PROFIBUS network. Additional EMC information is available in the AF-6 series Instruction Manual and Design Guides

NOTE
Ensure compliance with relevant national and local regulations, for example in protective ground connection.

2.1.3 Connection of the Cable Shield

The shield of the PROFIBUS cable must always be connected to ground at both ends, meaning the shield must be connected to ground in all stations connected to the PROFIBUS network. It is very important to have a low impedance ground connection of the shield, also at high frequencies. This can be obtained by connecting the surface of the shield to ground, for example by means of a cable clamp or a conductive cable connector. The adjustable frequency drive has various clamps and brackets to enable a proper ground connection of the PROFIBUS cable shield. The shield connection is shown in the section *Connecting the Network*.

2.1.4 Ground Connection

It is important that all stations connected to the PROFIBUS network are connected to the same ground potential. The ground connection must have a low HF (high frequency) impedance. This can be achieved by connecting a large surface area of the cabinet to ground, for example, by mounting the adjustable frequency drive on a conductive rear plate. Particularly when there are long distances between the stations in a PROFIBUS network, it can be necessary to use additional potential equalizing cables, connecting the individual stations to the same ground potential.



2.1.5 Cable Routing

The PROFIBUS communication cable must be kept away from motor and brake resistor cables to avoid coupling of high frequency noise from one cable to the other. Normally a distance of 8 in [200 mm] is sufficient, but maintaining the greatest possible distance between cables is generally recommended, especially where cables run in parallel over long distances.

If the PROFIBUS cable must cross a motor cable or brake resistor cable, the cables must cross at an angle of 90°.

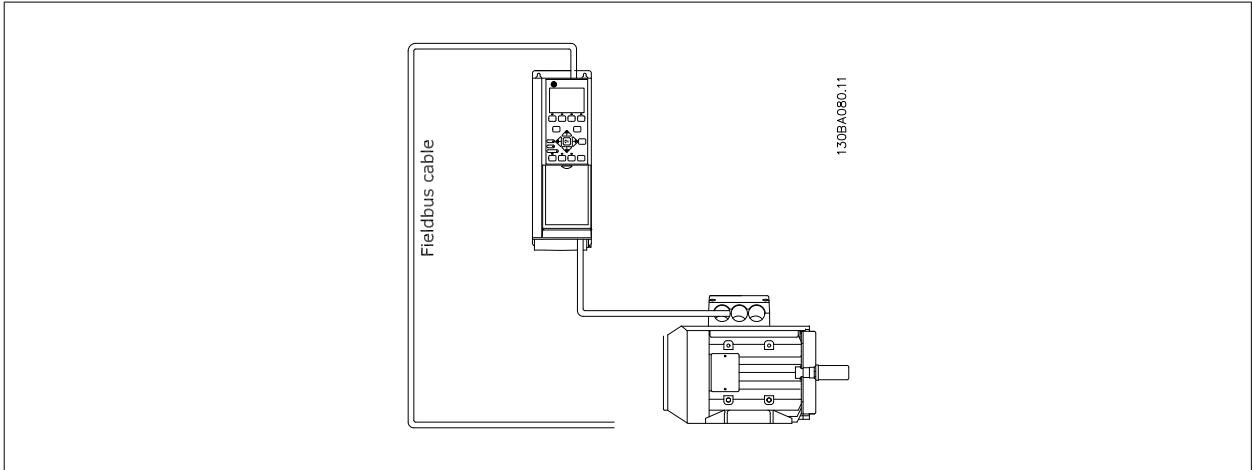

2.1.6 Connecting the Network

Proper termination of the network is essential. A mismatch of impedance may result in reflections on the line that will corrupt data transmission.

- The Profibus DP Communications Module has a suitable termination, activated by switch 1 located on the Profibus option. The switches must be on to terminate the network. The factory setting is off.
- Nodes at the physical ends of each segment must be terminated.
- When power to the Profibus DP Communications Module is down, please note that the termination is still active, although not functional.
- Most masters and repeaters are equipped with their own termination.
- If an external termination circuit consisting of three resistors is connected to the network, a 5 V DC power supply must be used. Terminal 66 and 67 can be used for this.
- The CS pin on the Profibus connector is Control Select. When option goes into active state and sends a message, the CS pin goes high (+5 Volts). This can be used to control optical transmitters etc. or for triggering measurement equipment like an oscilloscope.
- D-sub 9 connector.
If desired, a D-sub 9 adaptor can be added as an option.

Note: If the D-sub 9 adaptor is used, please be aware that the termination switch on the Profibus option is set to OFF, to avoid double termination, as the Profibus D-sub 9 connector also features a termination switch.

- 62 = RxD/TxD-P red cable (Siemens B)
- 63 = RxD/TxD-N green cable (Siemens A)
- 66 and 67 are for use with external terminator resistor only

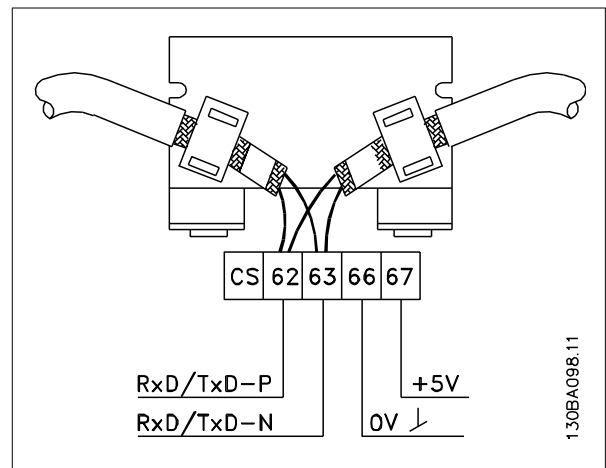



2

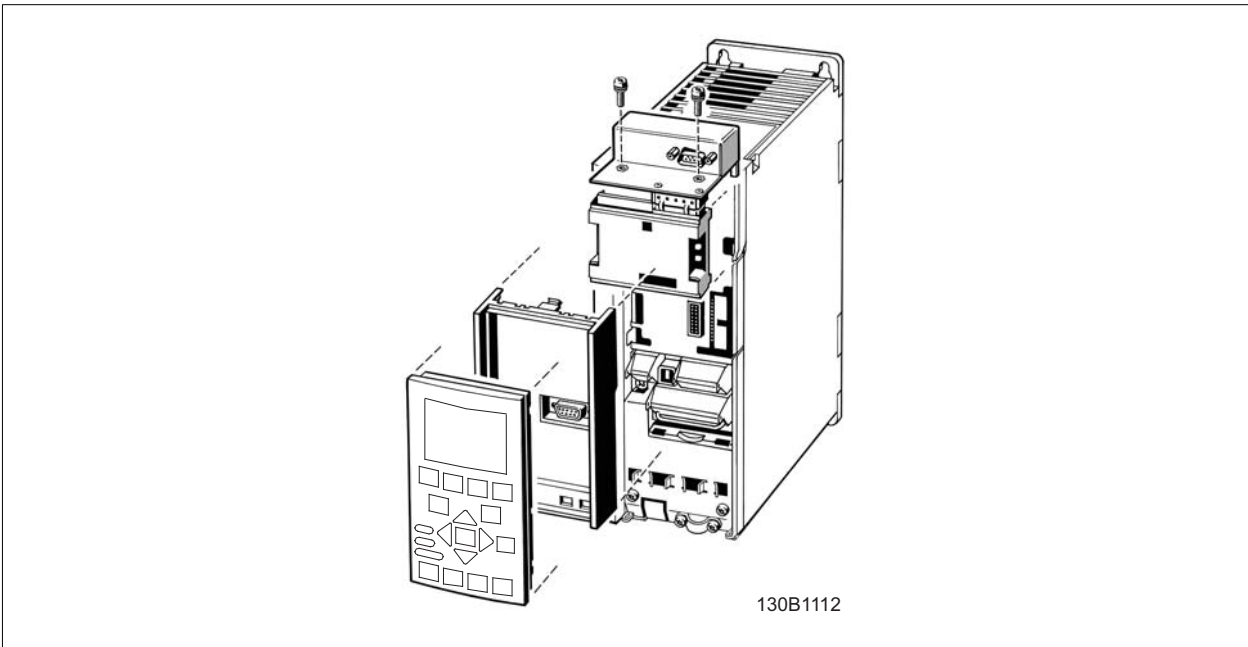
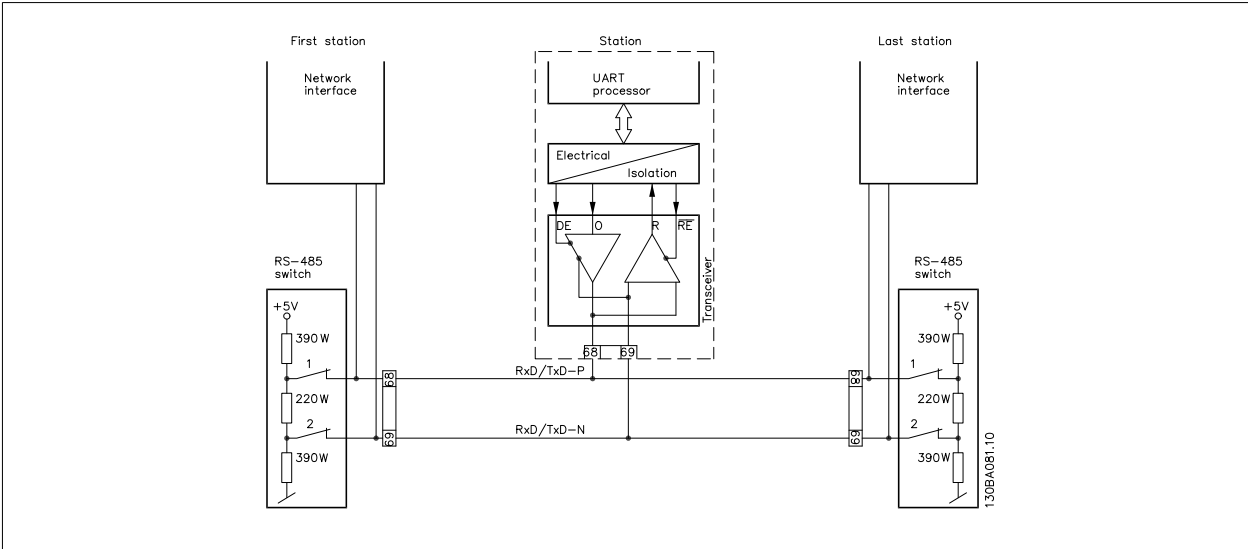



2.2 How to Install the Profibus DP Communications Module in Drive

To install the module in the drive you will need:

- The Profibus DP Communications Module (OPCPDP)
- Network option adaptor frame for the AF-6 Series drives.. This frame is deeper than the standard frame, to allow space for the network option beneath
- Cable holders

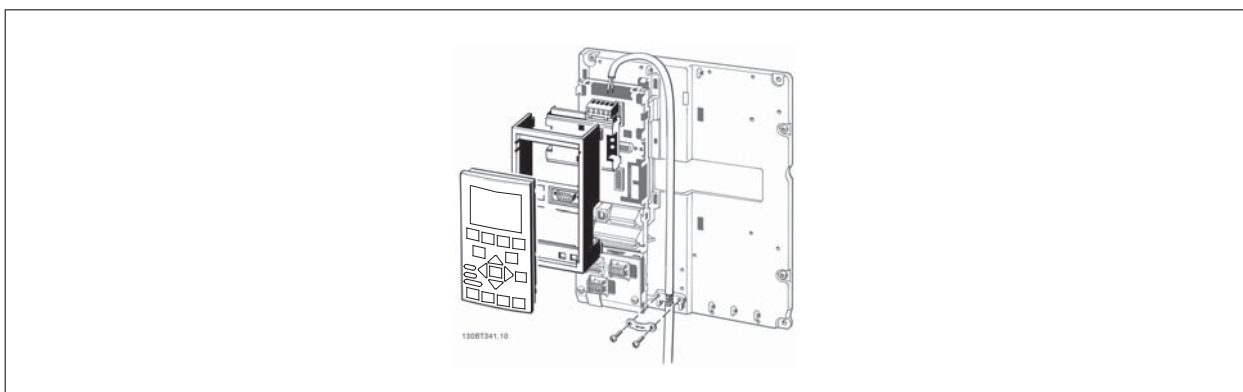
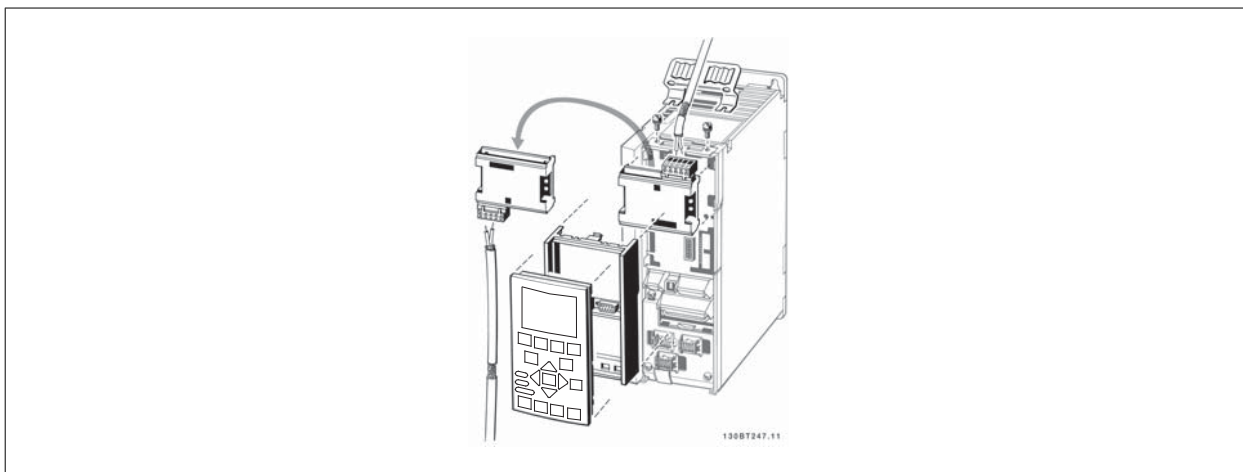
2

Instructions:

- Remove the keypad from the adjustable frequency drive
- Remove the frame located beneath and discard
- Push the module into place. Two positions are possible, with cable terminal facing either up or down. The cable up position is often most suitable when several adjustable frequency drives are installed side by side in a rack, as this position permits shorter cable lengths
- Push the network option adaptor frame into place
- Replace the keypad. - Attach cable
- Fasten the cable in place using cable holders
- The AF-6 Series Drives top surfaces have pre-bored threaded holes for attaching the cable holders to the unit





3 How to Configure the System

3.1 Configure the PROFIBUS Network

All PROFIBUS stations that are connected to the same network must have a unique station address.

The PROFIBUS address of the adjustable frequency drive can be selected via:

- Hardware switches
- PB-18 Node Address
- The PROFIBUS command SSA Set Station Address

3

3.1.1 Setting the PROFIBUS Address using the Hardware Switches

Using the hardware switches, it is possible to select an address range from 0 to 125 (factory setting 127) according to the table below:

Switch	8	7	6	5	4	3	2	1
Address value	Not used	+64	+32	+16	+8	+4	+2	+1
E.g., address 5	Not used	OFF	OFF	OFF	OFF	ON	OFF	ON
E.g., address 35	Not used	OFF	ON	OFF	OFF	OFF	ON	ON
E.g., address 82	Not used	ON	OFF	ON	OFF	OFF	ON	OFF

NOTE

Switch off the power supply before changing the hardware switches.

The address change will come into effect at the next power-up, and can be read in PB-18 Node Address.

Note the location and sequence of the hardware switches as illustrated in the figure opposite.

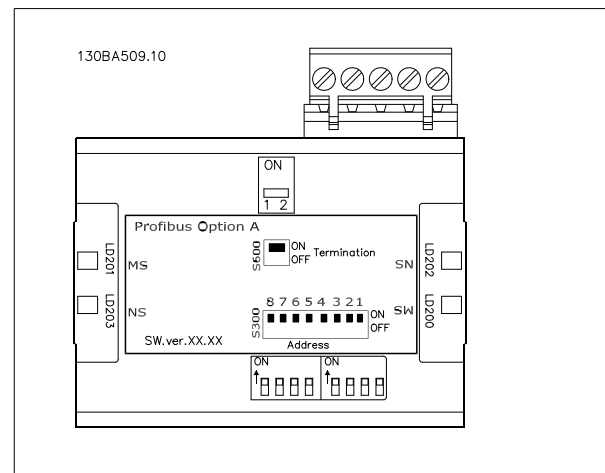

Setting the PROFIBUS Address via PB-18 Node Address:

Setting the address via PB-18 Node Address or the Profibus SSA command is possible, if the hardware switches are set to 126 or 127 (factory switch setting). The address change will come into effect at the next power-up.

Setting the PROFIBUS Address with the Set Station Address Command:

Setting the address via the "Set Station Address" command is possible, if the hardware switch is set to 126 or 127 (factory switch setting). Using the "Set Station Address" command, it is possible to lock the programmed address, which makes it impossible to change the address using this command. The address setting can be unlocked by changing the PB-18 Node Address or the address switch, followed by a power cycle. A new address is effective immediately after the "Set Station Address" command.



3.2 Configure the Master

3.2.1 GSD File

In order to configure a PROFIBUS Master, the configuration tool needs a GSD file for each type of slave on the network. The GSD file is a PROFIBUS DP standard text file containing the necessary communications set-up data for a slave. Download the GSD file for the AF-6 Series drives at www.geelectrical.com/drives.

3

The first step in configuration of the PROFIBUS master is to import the GSD file in the configuration tool. The steps outlined below show how to add a new GSD file to the Simatic Manager software tool. For each drive series, a GSD file is typically imported once only, following the initial installation of the software tool.

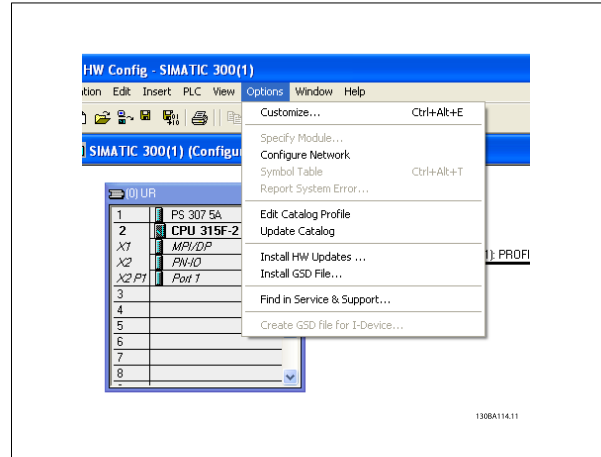

Using the browser for the GSD file, choose to install all files, which will mean that both a GSD file and a bitmap for the device will be imported into the hardware catalog.

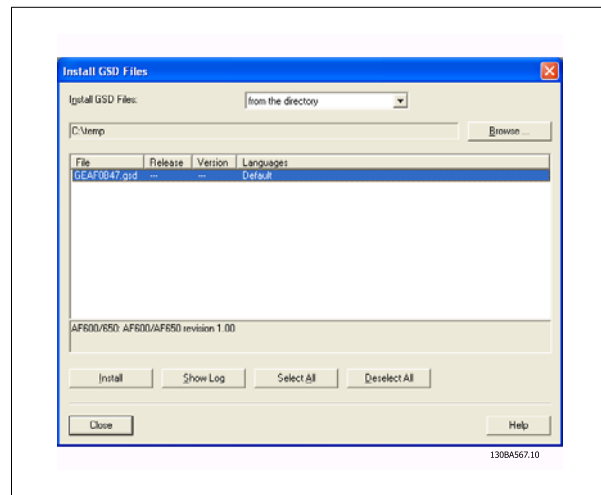



The AF-650 GP GSD file is now imported and will be accessible via the following path in the hardware catalog:

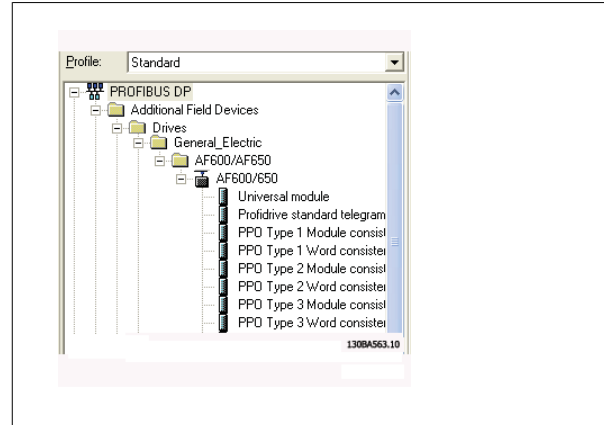

Open a project, set up the hardware and add a PROFIBUS master system. Select AF-6 Series then drag and drop it onto the PROFIBUS in the hardware diagram.

A window for the address of the AF-6 Series now appears. Select the address from the scroll-down list. Note that this address setting must match the previous address setting in PB-18 Node Address.

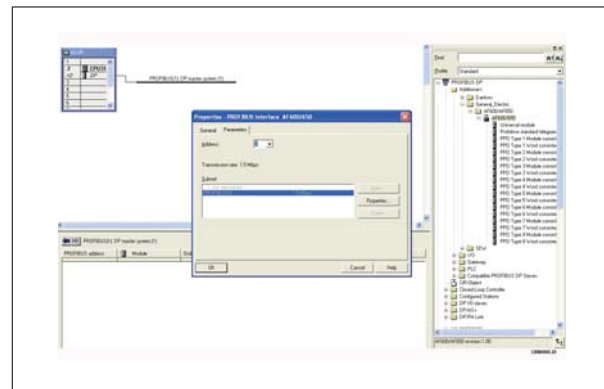
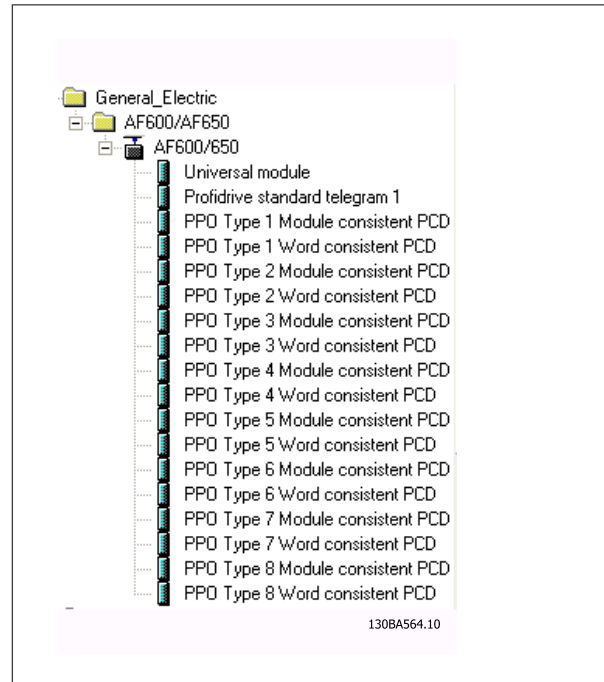



The next step is to set up the peripheral input and output data. Data set-up in the peripheral area is transmitted cyclically via PPO types. In the example below, a PPO type 6 Word consistent is dragged and dropped to the first slot.

See the PPO types section in *How to Control the Adjustable Frequency Drive* for more information.

3

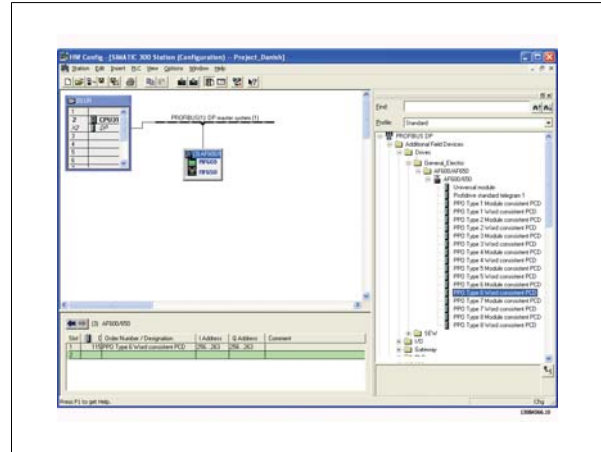

The configuration tool automatically assigns addresses in the peripheral address area. In this example, the input and output area have the following configuration:

PPO type 6:

PCD word number	1	2	3	4
Input address	256-257	258-259	260-261	262-263
Set-up	STW	MAV	Par. PB-16.2	Par. PB-16.3

3.1: PCD read (Drive to PLC)

PCD word number	1	2	3	4
Output address	256-257	258-259	260-261	262-263
Set-up	CTW	MRV	Par. PB-15.2	Par. PB-15.3

3.2: PCD write (PLC to Drive)

For Profibus SW version 2.x and higher, auto-configuration of process data is supported. This feature makes it possible to configure the process data (PB-15 *PCD Write Configuration* and PB-16 *PCD Read Configuration*) from the PLC/Master. To use Autoconfig, make sure the feature under *DP slave Properties* is enabled.

NOTE

DP V1 diagnostics is supported for Profibus SW version 2 and higher. This means that the default setting of the Profibus option is DP V1 diagnostics. If DP V0 diagnostics are required, the setting under *DP slave Properties* must be changed

Download the configuration file to the PLC. The PROFIBUS system should be able to go online and it will start to exchange data when the PLC is set to run mode.

3.3 Configure the Adjustable Frequency Drive

3.3.1 Drive Parameters

Pay particular attention to the following parameters when configuring the adjustable frequency drive with a PROFIBUS interface.



- K-40 [Hand] Button on Keypad. If the Hand button on the adjustable frequency drive is activated, control of the drive via the PROFIBUS interface is disabled.
- After an initial power-up, the adjustable frequency drive will automatically detect whether a network option is installed in slot A, and set O-02 Control Word Source to [Option A]. If an option is added or changed in or removed from an already commissioned drive, it will not change O-02 Control Word Source but enter trip mode, and the drive will display an error.
- O-10 Control Word Profile. Choose between the GE Drive Profile and the PROFdrive profile
- O-50 Coasting Select to O-56 Preset Reference Select. Selection of how to gate PROFIBUS control commands with digital input command of the control module.

NOTE
When O-01 Control Site is set to [2] Control word only, then the settings in O-50 Coasting Select to O-56 Preset Reference Select will be overruled, and all act on bus control.

- O-03 Control Word Time-out Time to O-05 End-of-Time-out Function. The reaction in the event of a network time out is set via these parameters
- PB-18 Node Address
- O-07 Diagnosis Trigger

3.3.2 LEDs

The two bi-color LEDs in the PROFIBUS module indicate the status of PROFIBUS communication

The LED marked NS indicates the network status, i.e., the cyclical communication to the PROFIBUS master. When this light shows constant green, then data exchange between the master and the adjustable frequency drive is active.

The LED marked MS indicates the module status, i.e., acyclical DP V1 communication from either a PROFIBUS master class 1 (PLC) or a master class 2 (DCT-10). When this light shows constant green, then DP V1 communication from master classes 1 and 2 is active.

For details of the full range of communications status indicated by the LEDs, please refer to the *Troubleshooting* chapter.

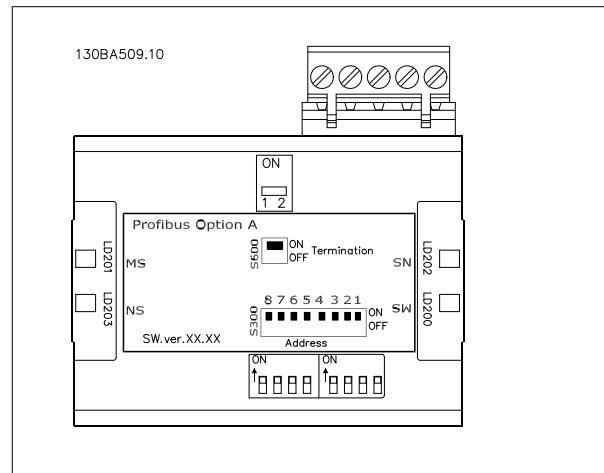





4 How to Control the Adjustable Frequency Drive

4.1 PPO Types

The PROFIBUS profile for adjustable frequency drives specifies a number of communication objects (parameter process data objects, PPO), which are suitable for data exchange between a process controller, such as a PLC, and adjustable frequency drives. All PPOs are defined for cyclic data transfer (i.e., DP V0), so that process data (PCD) and parameters (PCA) can be transferred from the master to the slave and vice versa. The figure below shows the PPO types available for the GE AF-650 GP & AF-600 FP drives.

PPO types 3, 4, 6, 7 and 8 are pure process data objects for applications requiring no cyclic parameter access. The PLC sends out process control data, and the adjustable frequency drive then responds with a PPO of the same length, containing process status data. The first two bytes of the process data area (PCD 1) comprise a fixed part present in all PPO types. The next two bytes (PCD 2) are fixed for PCD write entries (PB-15 *PCD Write Configuration* [1]), but configurable for PCD read entries (PB-16 *PCD Read Configuration* [1]). In the remaining bytes, from PCD 3 and on, the process data can be parameterized with process signals from the list on PB-23 *Parameters for Signals*.

Select the signals for transmission from the master to the adjustable frequency drive in PB-15 *PCD Write Configuration* (request from master to the adjustable frequency drive). Select the signals for transmission from the adjustable frequency drive to the master in PB-16 *PCD Read Configuration* (response: Drive -> master).

PPO types 1, 2 and 5 consist of a parameter channel and process data. The parameter channel can be used for reading and/or updating of parameters (successively). Alternatively, for better utilization of I/O and thus PLC capacity, parameters can be accessed via DP V1, in which case a pure process data object should be chosen (PPO type 3, 4, 6, 7 or 8).

The choice of PPO type is made in the master configuration, and is then automatically recorded in the adjustable frequency drive. No manual setting of PPO types in the adjustable frequency drive is required. The current PPO type can be read in PB-22 *Telegram Selection*.

In addition, all PPO types can be set up as word consistent or module consistent. For GE AF-650 GP & AF-600 FP drives, the process data area can be word or module consistent, whereas the parameter channel must always be module consistent. Module consistent data is transmitted as sets of interrelated words transferred simultaneously between the PLC program and the adjustable frequency drive. Word consistent data is transmitted as individual independent words between the PLC and the adjustable frequency drive.

Selection [1] *Standard message 1* is equivalent to PPO type 3.



PCV								PCD																				
Par. PB-15 + PB-16 index. no.:								1	2	3	4	5	6	7	8	9	10											
PCA	IND	PVA		CTW		MRV	PCD	PCD	PCD	PCD	PCD	PCD	PCD	PCD	PCD													
								STW	MAV																			
Byte no.	1	2	3	4	5	6	7	8	9	10	11	12	13	14	15	16	17	18	19	20	21	22	23	24	25	26	27	28
Type 1:																												
Type 2:																												
Type 3:																												
Type 4:																												
Type 5:																												
Type 6:																												
Type 7:																												
Type 8:																												

PCV:	Parameter Characteristics Value	CTW:	Control word
PCD:	Process Data	STW:	Status word
PCA:	Parameter Characteristics (Bytes 1, 2)	MRV:	Main reference value
IND:	Sub index (Byte 3. Byte 4 is not used)	MAV:	Main Actual Value (actual output frequency)
PVA:	Parameter value (Bytes 5 to 8)		



4.2 Process Data

Use the process data part of the PPO for controlling and monitoring the adjustable frequency drive via the PROFIBUS.

4.2.1 Process Control Data

Process data sent from the PLC to the adjustable frequency drive is defined as Process Control Data (PCD).

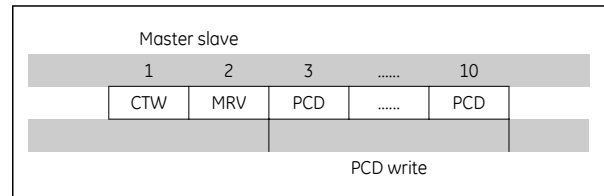

PCD 1 contains a 16-bit control word, where each bit controls a specific function of the adjustable frequency drive, see section *Control Profile*. PCD 2 contains a 16-bit speed setpoint in percentage format. See section *Reference Handling*

The content of PCD 3 to PCD 10 is programmed in *PB-15 PCD Write Configuration* and *PB-16 PCD Read Configuration*.

4.2.2 Process Status Data

Process data sent from the adjustable frequency drive contains information about the current state of the drive.

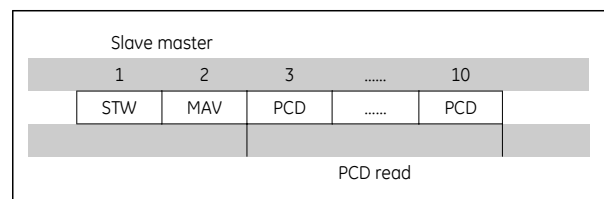

PCD 1 contains a 16-bit status word, where each bit contains information regarding a possible state of the adjustable frequency drive.

PCD 2 contains per default the value of the current speed of the adjustable frequency drive in percentage format (see section *Reference Handling*). PCD 2 can be configured to contain other process signals.

The content of PCD 3 to PCD 10 is programmed in *PB-16 PCD Read Configuration*.

4.2.3 Reference Handling

The reference handling in the GE AF-650 GP & AF-600 FP drives is an advanced mechanism that sums up references from different sources.

For more information on reference handling, please refer to the AF-650 GP or AF-600 FP Design Guides.

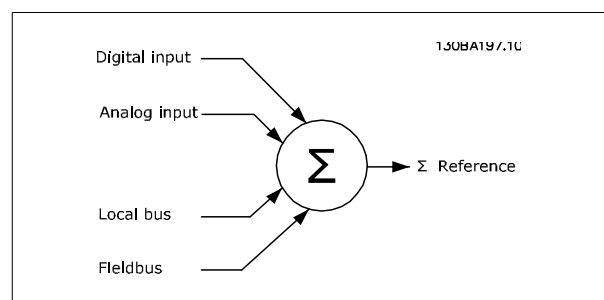

The reference, or speed set point (MRV, send via Profibus is always transmitted to the frequency converter in percentage format as integers represented in hexadecimal (0-4000 hex).

The reference (MRV) and feedback (MAV) are always scaled equally.



Depending on the setting of F-50 Reference Range the reference and MAV are scaled accordingly:

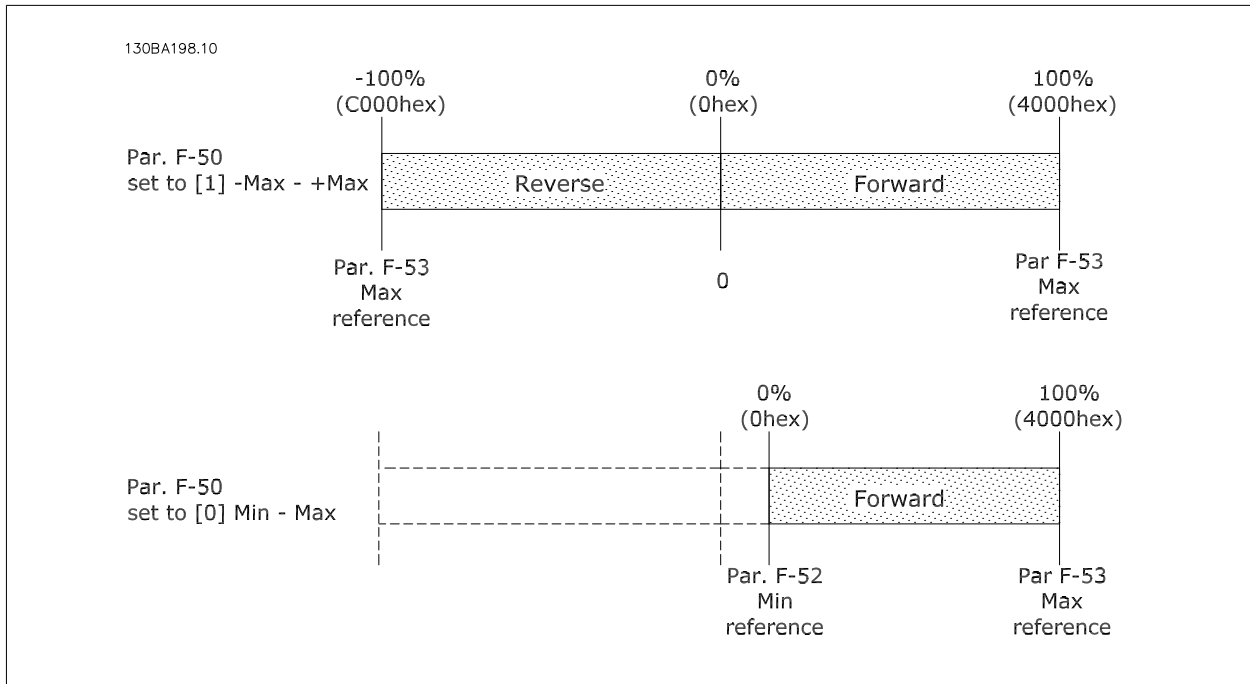

4

NOTE

If F-50 Reference Range is set to [0] Min - Max, a negative reference will be handled as 0%.

The actual output of the frequency converter is limited by the speed limit parameters *Motor Low/High Speed Limit [RPM/Hz]* in F-18 *Motor Speed Low Limit [RPM]* to F-15 *Motor Speed High Limit [Hz]*.

The final speed limit is set by F-03 *Max Output Frequency 1*.

The reference and the MAV have the format which appears from the table

MRV / MAV	Integer in hex	Integer in decimal
100%	4000	16.384
75%	3000	12.288
50%	2000	8.192
25%	1000	4.096
0%	0	0
-25%	F000	-4.096
-50%	E000	-8.192
-75%	D000	-12.288
-100%	C000	-16.384

NOTE

Negative numbers are formed as two's complement.

NOTE

The data type for MRV and MAV is a N2 16 bit standardised value, meaning it can express a range from -200% to +200% (8001 to 7FFF).



H-40 *Configuration Mode* set to [0] *Speed open loop*.

F-50 *Reference Range* set to [0] *Min - Max*.

F-52 *Minimum Reference* set to 100 RPM.

F-53 *Maximum Reference* set to 3000 RPM.

MRV / MAV		Actual Speed
0%	0 hex	100 RPM
25%	1000 hex	825 RPM
50%	2000 hex	1550 RPM
75%	3000 hex	2275 RPM
100%	4000 hex	3000 RPM

4.2.4 Process Control Operation

In process control operation, H-40 *Configuration Mode* is set to [3] *Process*.

The reference range in F-50 *Reference Range* is always [0] *Min - Max*.

- MRV represents the process setpoint.

- MAV expresses the actual process feedback (range +/- 200%).

4.2.5 Influence of the Digital Input Terminals upon Drive Control Mode, O-50 *Coasting Select* to O-56 *Preset Reference Select*

The influence of the digital input terminals upon control of the adjustable frequency drive can be programmed in O-50 *Coasting Select* to O-56 *Preset Reference Select*. Please note the O-01 *Control Site* overrides the settings in O-50 *Coasting Select* to O-56 *Preset Reference Select*, and Terminal 37 *Coasting Stop (safe)* overrides any parameter. Terminal 37 *Safe Stop* is standard on the AF-650 GP only.

Each of the digital input signals can be programmed to logic AND, logic OR, or to have no relation to the corresponding bit in the control word. In this way a specific control command, i.e., stop / coast, can be initiated by network only, network AND digital input, or ether network OR digital input terminal.



In order to control the adjustable frequency drive via PROFIBUS, O-50 *Coasting Select* must be set to either Bus [1], or to Logic AND [2], and O-01 *Control Site* must be set to [0] or [2].

More detailed information and examples of logical relationship options are provided in the *Troubleshooting chapter*.

4.3 Control Profile

The adjustable frequency drive can be controlled according to the PROFIdrive profile, or the GE Drive profile. Select the desired control profile in O-10 *Control Word Profile*. The choice of profile affects the control and status word only.

The *PROFIdrive control profile* and *GE Drive control profile* sections provide a detailed description of control and status data.

4.4 PROFIdrive Control Profile

4.4.1 PROFIdrive Control Profile

This section describes the functionality of the control word and status word in the PROFIdrive profile. Select this profile by setting O-10 *Control Word Profile*.



4.4.2 Control Word according to PROFIdrive Profile (CTW)

The control word is used to send commands from a master (a PC, for example) to a slave.

Bit	Bit = 0	Bit = 1
00	OFF 1	ON 1
01	OFF 2	ON 2
02	OFF 3	ON 3
03	Coasting	No coasting
04	Quick stop	Accel/Decel
05	Hold frequency output	Use Accel/Decel
06	Accel/Decel stop	Start
07	No function	Reset
08	Jog 1 OFF	Jog 1 ON
09	Jog 2 OFF	Jog 2 ON
10	Data invalid	Data valid
11	No function	Slow-down
12	No function	Catch up
13	Parameter set-up	Selection lsb
14	Parameter set-up	Selection msb
15	No function	Reverse

Explanation of the Control Bits

Bit 00, OFF 1/ON 1

Normal ramp stop using the ramp times of the actual selected ramp.

Bit 00 = "0" leads to the stop and activation of the output relay 1 or 2 if the output frequency is 0 Hz and if [Relay 123] has been selected in *E-24 Function Relay*. When bit 00 = "1", the adjustable frequency drive is in State 1: "Switching on inhibited".

Please refer to the PROFIdrive State Transition Diagram at the end of this section.

Bit 01, OFF 2/ON 2

Coasting stop

When bit 01 = "0", a coasting stop and activation of the output relay 1 or 2 occurs if the output frequency is 0 Hz and if [Relay 123] has been selected in *E-24 Function Relay*.

When bit 01 = "1", the adjustable frequency drive is in State 1: "Switching on inhibited". Please refer to the PROFIdrive State Transition Diagram at the end of this section.

Bit 02, OFF 3/ON 3

Quick stop using the ramp time of *C-23 Quick Stop Decel Time*. When bit 02 = "0", a quick stop and activation of the output relay 1 or 2 occurs if the output frequency is 0 Hz and if [Relay 123] has been selected in *E-24 Function Relay*.

When bit 02 = "1", the adjustable frequency drive is in State 1: "Switching on inhibited".

Please refer to the PROFIdrive State Transition Diagram at the end of this section.

Bit 03, Coasting/No coasting

Coasting stop bit 03 = "0" leads to a stop. When bit 03 = "1", the adjustable frequency drive can start if the other start conditions are satisfied.

NOTE

The selection in *O-50 Coasting Select* Coasting select determines how bit 03 is linked with the corresponding function of the digital inputs.

**Bit 04, Quick stop/Accel/Decel**

Quick stop using the ramp time of *C-23 Quick Stop Decel Time*.

When bit 04 = "0", a quick stop occurs.

When bit 04 = "1", the adjustable frequency drive can start if the other start conditions are satisfied.

NOTE

The selection in *O-51 Quick Stop Select* determines how bit 04 is linked with the corresponding function of the digital inputs.

Bit 05, Hold frequency output/Use Accel/Decel

When bit 05 = "0", the current output frequency is maintained even if the reference value is modified.

When bit 05 = "1", the adjustable frequency drive can perform its regulating function again; operation occurs according to the respective reference value.

Bit 06, Decel stop/Start

Normal ramp stop using the ramp times of the actual ramp as selected. In addition, activation of the output relay 01 or 04 if the output frequency is 0 Hz if Relay 123 has been selected in *E-24 Function Relay*. Bit 06 = "0" leads to a stop. When bit 06 = "1", the adjustable frequency drive can start if the other start conditions are satisfied.

NOTE

The selection in *O-53 Start Select* determines how bit 06 is linked with the corresponding function of the digital inputs.

Bit 07, No function/Reset

Reset after switching off.

Acknowledges event in fault buffer.

When bit 07 = "0", no reset occurs.

When there is a slope change of bit 07 to "1", a reset occurs after switching off.

Bit 08, Jog 1 OFF/ON

Activation of the pre-programmed speed in *O-90 Bus Jog 1 Speed*. JOG 1 is only possible if bit 04 = "0" and bit 00 - 03 = "1".

Bit 09, Jog 2 OFF/ON

Activation of the pre-programmed speed in *O-91 Bus Jog 2 Speed*. JOG 2 is only possible if bit 04 = "0" and bit 00 - 03 = "1".

Bit 10, Data invalid/valid

Is used to tell the adjustable frequency drive whether the control word is to be used or ignored. Bit 10 = "0" causes the control word to be ignored, Bit 10 = "1" causes the control word to be used. This function is relevant, because the control word is always contained in the message, regardless of which type of message is used, i.e., it is possible to turn off the control word if you do not wish to use it in connection with updating or reading parameters.

Bit 11, No function/Slow-down

Is used to reduce the speed reference value by the amount given in *F-62 Catch up/speed down value*. When bit 11 = "0", no modification of the reference value occurs. When bit 11 = "1", the reference value is reduced.

Bit 12, No function/Catch up

Is used to increase the speed reference value by the amount given in *F-62 Catch up/speed down value*.

When bit 12 = "0", no modification of the reference value occurs.

When bit 12 = "1", the reference value is increased.

If both - slowing down and accelerating - are activated (bit 11 and 12 = "1"), slowing down has priority, i.e., the speed reference value will be reduced.



Bits 13/14, Set-up selection

Bits 13 and 14 are used to choose between the four parameter set-ups according to the following table:

The function is only possible if *Multi Set-up* has been chosen in *K-10 Active Set-up*. The selection in *O-55 Set-up Select* determines how bits 13 and 14 are linked with the corresponding function of the digital inputs. Changing set-up while running is only possible if the set-ups have been linked in *K-12 This Set-up Linked to*.

Set-up	Bit 13	Bit 14
1	0	0
2	1	0
3	0	1
4	1	1

Bit 15, No function/Reverse

Bit 15 = "0" causes no reversing.

Bit 15 = "1" causes reversing.

Note: In the factory setting reversing is set to *digital* in *O-54 Reversing Select*.

NOTE

Bit 15 causes reversing only when *Ser. communication*, *Logic or* or *Logic and* is selected.

4

4.4.3 Status Word according to PROFIdrive Profile (STW)

The status word is used to notify a master (e.g., a PC) about the status of a slave.

Bit	Bit = 0	Bit = 1
00	Control not ready	Control ready
01	Drive not ready	Drive ready
02	Coasting	Enable
03	No error	Trip
04	OFF 2	ON 2
05	OFF 3	ON 3
06	Start possible	Start not possible
07	No warning	Warning
08	Speed ≠ reference	Speed = reference
09	Local operation	Bus control
10	Out of frequency limit	Frequency limit ok
11	No operation	In operation
12	Drive OK	Stopped, autostart
13	Voltage OK	Voltage exceeded
14	Torque OK	Torque exceeded
15	Timer OK	Timer exceeded

Explanation of the Status Bits

Bit 00, Control not ready/ready

When bit 00 = "0", bit 00, 01 or 02 of the control word is "0" (OFF 1, OFF 2 or OFF 3) - or the adjustable frequency drive is switched off (trip).

When bit 00 = "1", the adjustable frequency drive control is ready, but there is not necessarily power supply to the unit present (in the event of external 24 V supply of the control system).

Bit 01, Drive not ready/ready

Same significance as bit 00, however, there is a supply of the power unit. The adjustable frequency drive is ready when it receives the necessary start signals.

Bit 02, Coasting/Enable

When bit 02 = "0", bit 00, 01 or 02 of the control word is "0" (OFF 1, OFF 2 or OFF 3 or coasting) - or the adjustable frequency drive is switched off (trip).

When bit 02 = "1", bit 00, 01 or 02 of the Control word is "1"; the adjustable frequency drive has not tripped.

Bit 03, No error/Trip

When bit 03 = "0", no error condition of the adjustable frequency drive exists.

When bit 03 = "1", the adjustable frequency drive has tripped and requires a reset signal before it can start.

Bit 04, ON 2/OFF 2

When bit 01 of the control word is "0", then bit 04 = "0".

When bit 01 of the control word is "1", then bit 04 = "1".

Bit 05, ON 3/OFF 3

When bit 02 of the control word is "0", then bit 05 = "0".

When bit 02 of the control word is "1", then bit 05 = "1".

Bit 06, Start possible/Start not possible

If PROFIdrive has been selected in *O-10 Control Word Profile*, bit 06 will be "1" after a switch-off acknowledgement, after activation of OFF2 or OFF3, and after switching on the AC line voltage. Start not possible will be reset, with bit 00 of the control word being set to "0" and bit 01, 02 and 10 being set to "1".

Bit 07, No warning/Warning

Bit 07 = "0" means that there are no warnings.

Bit 07 = "1" means that a warning has occurred.

Bit 08, Speed ≠ reference / Speed = reference

When bit 08 = "0", the current speed of the motor deviates from the set speed reference value. This may occur, for example, when the speed is being changed during start/stop through ramp up/down.

When bit 08 = "1", the current speed of the motor corresponds to the set speed reference value.

Bit 09, Local operation/Bus control

Bit 09 = "0" indicates that the adjustable frequency drive has been stopped by means of the stop button on the control panel, or that [Linked to hand] or [Local] has been selected in *F-02 Operation Method*.

When bit 09 = "1", the adjustable frequency drive can be controlled through the serial interface.

Bit 10, Out of frequency limit/Frequency limit OK

When bit 10 = "0", the output frequency is outside the limits set in *H-72 Warning Speed Low* and *H-73 Warning Speed High*. When bit 10 = "1", the output frequency is within the indicated limits.

Bit 11, No operation/Operation

When bit 11 = "0", the motor does not turn.

When bit 11 = "1", the adjustable frequency drive has a start signal, or the output frequency is higher than 0 Hz.

Bit 12, Drive OK/Stopped, autostart

When bit 12 = "0", there is no temporary overloading of the inverter.

When bit 12 = "1", the inverter has stopped due to overloading. However, the adjustable frequency drive has not switched off (trip) and will start again after the overloading has ended.

Bit 13, Voltage OK/Voltage exceeded

When bit 13 = "0", the voltage limits of the adjustable frequency drive are not exceeded.

When bit 13 = "1", the direct voltage in the intermediate circuit of the adjustable frequency drive is too low or too high.



Bit 14, Torque OK/Torque exceeded

When bit 14 = "0", the motor torque is below the limit selected in F-40 Torque Limiter (Driving) and F-41 Torque Limiter (Braking). When bit 14 = "1", the limit selected in F-40 Torque Limiter (Driving) or F-41 Torque Limiter (Braking) is exceeded.

Bit 15, Timer OK/Timer exceeded

When bit 15 = "0", the timers for the thermal motor protection and electronic overload protection have not exceeded 100%.

When bit 15 = "1", one of the timers has exceeded 100%.

4.4.4 PROFIdrive State - Transition Diagram

4

In the PROFIdrive Control profile, the control bits 0 to 3 perform the basic start-up / power-down functions, whereas the control bits 4 to 15 perform application-oriented control.

The figure below shows the basic state-transition diagram, where control bits 0 to 3 control the transitions, and the corresponding status bit indicates the actual state. The black bullets indicate the priority of the control signals, where fewer bullets indicate lower priority, and more bullets indicate higher priority.

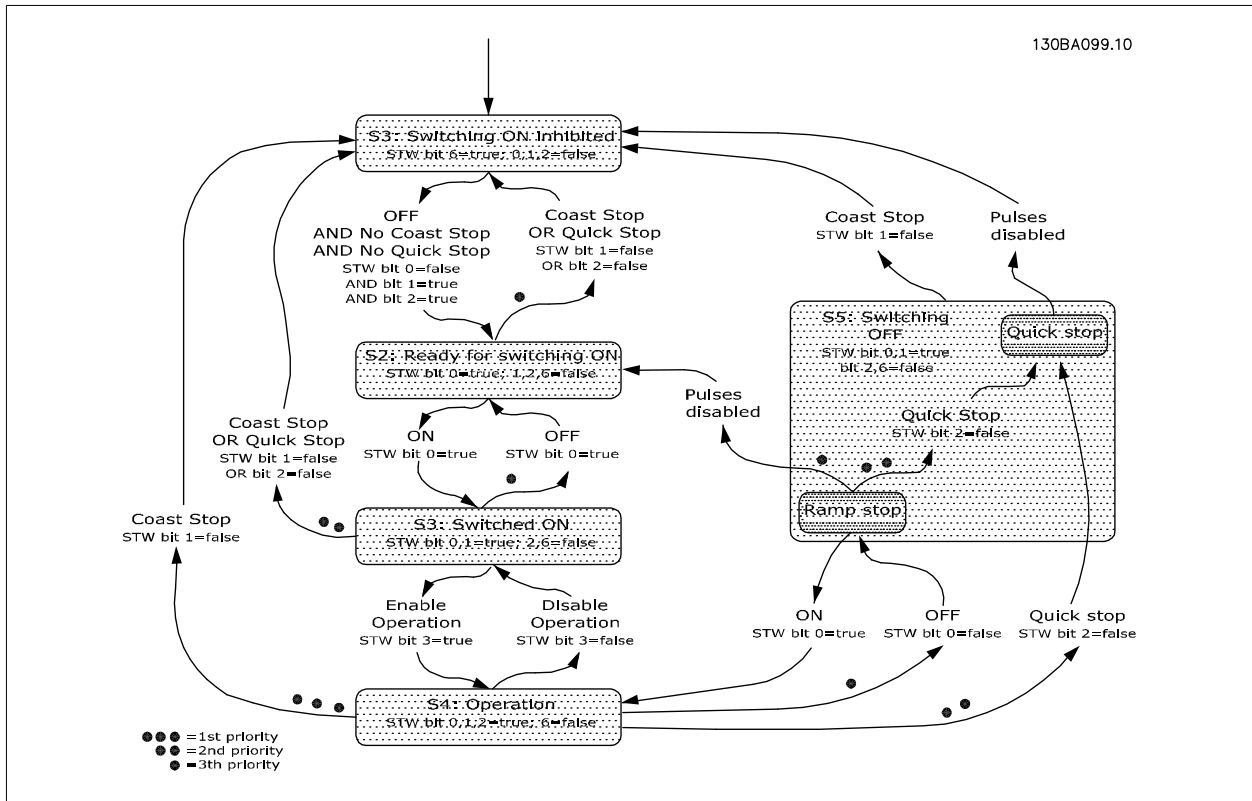



4.5 GE Drive Control Profile

4.5.1 Control Word according to Drive Profile (CTW)

To select GE Drive protocol in the control word, O-10 *Control Word Profile* must be set to GE Drive protocol [0]. The control word is used to send commands from a master (PLC or PC) to a slave (adjustable frequency drive).

Please refer to *Application Examples* for an example of a control word message using PPO type 3.

Bit	Bit value = 0	Bit value = 1
00	Reference value	external selection lsb
01	Reference value	external selection msb
02	DC brake	Accel/Decel
03	Coasting	No coasting
04	Quick stop	Accel/Decel
05	Hold output frequency	Use Accel/Decel
06	Accel/Decel stop	Start
07	No function	Reset
08	No function	Jog
09	Ramp 1	Accel/Decel 2
10	Data invalid	Data valid
11	No function	Relay 01 active
12	No function	Relay 04 active
13	Parameter set-up	selection lsb
14	Parameter set-up	selection msb
15	No function	Reverse

4

Explanation of the Control Bits

Bits 00/01 Reference value

Bits 00 and 01 are used to choose between the four reference values, which are pre-programmed in C-05 *Multi-step Frequency 1 - 8* according to the following table:

NOTE

In O-56 *Preset Reference Select*, a selection is made to define how Bit 00/01 gates with the corresponding function on the digital inputs.

Programmed ref. value	Parameter	Bit 01	Bit 00
1	C-05 [0]	0	0
2	C-05 [1]	0	1
3	C-05 [2]	1	0
4	C-05 [3]	1	1

Bit 02, DC brake

Bit 02 = 0 leads to DC braking and stop. Braking current and duration are set in B-01 *DC Brake Current* and B-02 *DC Braking Time*. Bit 02 = 1 leads to ramping.

Bit 03, Coasting

Bit 03 = 0 causes the adjustable frequency drive to immediately "let go" of the motor (the output transistors are "shut off"), so that it coasts to a standstill.



Bit 03 = 1 enables the adjustable frequency drive to start the motor if the other starting conditions have been fulfilled.

NOTE

In *O-50 Coasting Select*, a selection is made to define how Bit 03 gates with the corresponding function on a digital input.

Bit 04, Quick stop

Bit 04 = 0 causes a stop, in which the motor speed is ramped down to stop via *C-23 Quick Stop Decel Time*.

Bit 05, Hold output frequency

Bit 05 = 0 causes the present output frequency (in Hz) to freeze. The frozen output frequency can then be changed only by means of the digital inputs (*E-01 Terminal 18 Digital Input* to *E-06 Terminal 33 Digital Input*) programmed to *Speed up* and *Slow*.

NOTE

If freeze output is active, the adjustable frequency drive can only be stopped by the following:

- Bit 03 Coasting stop
- Bit 02 DC braking
- Digital input (*E-01 Terminal 18 Digital Input* to *E-06 Terminal 33 Digital Input*) programmed to *DC braking*, *coasting stop* or *reset and coasting stop*.

Bit 06, Ramp stop/start:

Bit 06 = 0 causes a stop, in which the motor speed is ramped down to stop via the selected *ramp-down* parameter.

Bit 06 = 1" permits the adjustable frequency drive to start the motor, if the other starting conditions have been fulfilled.

NOTE

In *O-53 Start Select*, a selection is made to define how Bit 06 Ramp stop/start gates with the corresponding function on a digital input.

Bit 07, Reset

Bit 07 = "0" does not cause a reset. Bit 07 = "1" causes the reset of a trip. Reset is activated on the signals leading edge, i.e., when changing from logic "0" to logic "1".

Bit 08, Jog

Bit 08 = "1" causes the output frequency to be determined by *C-21 Jog Speed [RPM]*.

Bit 09, Selection of ramp 1/2

Bit 09 = "0" means that ramp 1 is active (*H-07 Accel/Decel Time 1 Type*, *F-07 Accel Time 1*, *F-08 Decel Time 1*, *SP-71 Accl Time 1 S-ramp Rat at Accl Start*, *SP-72 Accl Time 1 S-ramp Rat at Accl End*).

Bit 09 = "1" means that ramp 2 (*SP-76 Accel/Decel Time 2 Type* to *SP-81 Decl Time 2 S-ramp Rat at Decl Start*) is active.

Bit 10, Data not valid/Data valid

Is used to tell the adjustable frequency drive whether the control word is to be used or ignored. Bit 10 = "0" causes the control word to be ignored.

Bit 10 = "1" causes the control word to be used. This function is relevant, because the control word is always contained in the message, regardless of which type of message is used, i.e., it is possible to turn off the control word if you do not wish to use it in connection with updating or reading parameters.

Bit 11, Relay 01

Bit 11 = "0" Relay not activated.

Bit 11 = "1" Relay 01 activated, provided control word bit 11 has been chosen in *E-24 Function Relay*.

Bit 12, Relay 04

Bit 12 = "0" Relay 04 has not been activated.



Bit 12 = "1" Relay 04 has been activated, provided *Control word bit 12* has been chosen in *E-24 Function Relay*.

Bit 13/14, Selection of set-up

Bits 13 and 14 are used to choose from the four menu set-ups according to the following table:

Set-up	Bit 14	Bit 13
1	0	0
2	0	1
3	1	0
4	1	1

The function is only possible when *Multi Set-ups* is selected in *K-10 Active Set-up*.

NOTE

In *O-55 Set-up Select*, a selection is made to define how Bit 13/14 gates with the corresponding function on the digital inputs.

4

Bit 15 Reverse

Bit 15 = "0" causes no reversing.

Bit 15 = "1" causes reversing.

4.5.2 Status Word according to GE Drive Profile (STW)

The status word is used to inform the master (e.g., a PC) of the operation mode of the slave (adjustable frequency drive).

Please refer to the application examples for an example of a status word message using PPO type 3.

Explanation of the Status Bits

Bit 00, Control not ready/ready

Bit 00 = "0" means that the adjustable frequency drive has tripped.

Bit 00 = "1" means that the adjustable frequency drive controls are ready, but that the power component is not necessarily receiving any power supply (in case of external 24 V supply to controls).

Bit 01, Drive ready

Bit 01 = "1". The adjustable frequency drive is ready for operation, but there is an active coasting command via the digital inputs or via serial communication.

Bit 02, Coasting stop

Bit 02 = "0". The adjustable frequency drive has released the motor.

Bit 02 = "1". The adjustable frequency drive can start the motor when a start command is given.

Bit 03, No error/trip

Bit 03 = "0" means that the adjustable frequency drive is not in fault mode.

Bit 03 = "1" means that the adjustable frequency drive is tripped, and that a reset signal is required to re-establish operation.

Bit 04, No error/error (no trip)

Bit 04 = "0" means that the adjustable frequency drive is not in fault mode.

Bit 04 = 1 means that there is an adjustable frequency drive error but no trip.

Bit	Bit = 0	Bit = 1
00	Control not ready	Control ready
01	Drive not ready	Drive ready
02	Coasting	Enable
03	No error	Trip
04	No error	Error (no trip)
05	Reserved	-
06	No error	Triplock
07	No warning	Warning
08	Speed reference	Speed = reference
09	Local operation	Bus control
10	Out of frequency limit	Frequency limit ok
11	No operation	In operation
12	Drive OK	Stopped, autostart
13	Voltage OK	Voltage exceeded
14	Torque OK	Torque exceeded
15	Timer OK	Timer exceeded

Bit 05, Not used

Bit 05 is not used in the status word.

Bit 06, No error / triplock

Bit 06 = "0" means that the adjustable frequency drive is not in fault mode.

Bit 06 = "1" means that the adjustable frequency drive is tripped and locked.

Bit 07, No warning/warning

Bit 07 = "0" means that there are no warnings.

Bit 07 = "1" means that a warning has occurred.

Bit 08, Speed reference/speed = reference

Bit 08 = "0" means that the motor is running, but that the present speed is different from the preset speed reference. It might, for example, be the case while the speed is being ramped up/down during start/stop.

Bit 08 = "1" means that the present motor present speed matches the preset speed reference.

Bit 09, Local operation/bus control

Bit 09 = "0" means that [STOP/RESET] is activated on the control unit, or that *Local control* in *F-02 Operation Method* is selected. It is not possible to control the adjustable frequency drive via serial communication.

Bit 09 = "1" means that it is possible to control the adjustable frequency drive via the network/ serial communication.

Bit 10, Out of frequency limit

Bit 10 = "0", if the output frequency has reached the value in *F-18 Motor Speed Low Limit [RPM]* or *F-17 Motor Speed High Limit [RPM]*.

Bit 10 = "1" means that the output frequency is within the defined limits.

Bit 11, No operation/in operation

Bit 11 = "0" means that the motor is not running.

Bit 11 = "1" means that the adjustable frequency drive has a start signal or that the output frequency is greater than 0 Hz.

Bit 12, Drive OK/stopped, autostart

Bit 12 = "0" means that there is no temporary overtemperature on the inverter.

Bit 12 = "1" means that the inverter has stopped because of overtemperature, but that the unit has not tripped and will resume operation once the overtemperature stops.

Bit 13, Voltage OK/limit exceeded

Bit 13 = "0" means that there are no voltage warnings.

Bit 13 = "1" means that the DC voltage in the adjustable frequency drives intermediate circuit is too low or too high.

Bit 14, Torque OK/limit exceeded

Bit 14 = "0" means that the motor current is lower than the torque limit selected in *F-40 Torque Limiter (Driving)* or *F-41 Torque Limiter (Braking)*.

Bit 14 = "1" means that the torque limit in *F-40 Torque Limiter (Driving)* and *F-41 Torque Limiter (Braking)* has been exceeded.

Bit 15, Timer OK/limit exceeded

Bit 15 = "0" means that the timers for motor thermal protection and electronic overload protection, respectively, have not exceeded 100%.

Bit 15 = "1" means that one of the timers has exceeded 100%.



4.6 Synchronize and Freeze

The control commands SYNC/UNSYNC and FREEZE/UNFREEZE are broadcast functions.

SYNC/UNSYNC is used to synchronize control commands and/or speed reference to all the connected adjustable frequency drives.

FREEZE/UNFREEZE is used to freeze the status feedback in the slaves to get synchronized feedback from all connected slaves.

The synchronize and freeze commands affect only process data (the PCD part of the PPO).

4.6.1 SYNC/UNSYNC

SYNC/UNSYNC can be used to obtain simultaneous reactions in several slaves, for example synchronized start, stop or speed change. A SYNC command will freeze the relevant control word and speed reference. Incoming process data will be stored but not used until a new SYNC command or an UNSYNC command is received.

An UNSYNC command stops the synchronization mechanism and enables normal DP data exchange.

4.6.2 FREEZE/UNFREEZE

FREEZE/UNFREEZE can be used for simultaneous reading of process data, for example output current, from several slaves.

A FREEZE command will freeze the actual values and upon request the slave will send back the value that was present when the FREEZE command was received.

Upon receipt of an UNFREEZE command, the values will once again be continuously updated and the slave will return a present value, i.e., a value generated by conditions at present time.

The values will be updated when a new FREEZE or UNFREEZE command is received.





5 How to Access the Parameters

5.1 Parameter Access in General

In an automated system, adjustable frequency drive parameters can be accessed either from the process controller (i.e., PLC), or from various kinds of HMI equipment. For parameter access from controllers and HMI, please observe the following:

AF-650 GP & AF-600 FP drive parameters are located in four separate set-ups. Parameter access in the drive is performed via several separated parameter channels, which can be used individually to access a certain parameter set-up. Select the desired set-up in *K-11 Edit Set-up* or *PB-70 Edit Set-up*.

Using this mechanism it is possible to read or write to and from parameters in a certain set-up from a master class 1, e.g., a PLC, and simultaneously access parameters in a different set-up from a master class 2, e.g., a PC tool, without interfering with the set-up selection for the programming sources.

Parameters can be accessed via the following sites:

Keypad on AF-650 GP & AF-600 FP drive

GE Drive Protocol on RS485 or USB

Cyclical data access on DP V0 (PCV Channel)

PROFIBUS Master Class 1

PROFIBUS Master Class 2 (3 connections possible)



Please note that although these parameter channels are separated, data conflict can occur if write to parameters is made from a HMI unit into a set-up which is actively in use by the adjustable frequency drive or the process controller (e.g., a PLC).

5.1.1 Data Store

Parameter write via the PCV channel (DP V0) will be stored in RAM only. If data has to be stored in non-volatile memory, the *PB-71 Profibus Save Data Values* can be used for storing one or more set-ups.

Using DP V1 access, parameters can be stored either in RAM or non-volatile memory by choice of a specific write request command. Non-stored data can at any time be stored in non-volatile memory by activating *PB-71 Profibus Save Data Values*.

5.1.2 Read / Write in Double Word Format, DP V1

Using the special Request IDs 0X51 (read) and 0X52 (write), it is possible to read and write to all parameters containing numeric values in a general format of double word. The value element must be right aligned and unused MSBs filled with zeros.

Example: Read of a parameter of type U8 will be transmitted as 00 00 00 xx, where xx is the value to be transmitted. The data type signaled by the message will be 43h (dword).

Please refer to the table *Request/ Response Attributes* later in this chapter.

Access the parameters as follows.



5.1.3 PROFIBUS DP V1

Using the acyclic DP V1 transmission it is possible to read and write parameter values, as well as to read a number of descriptive attributes for each parameter. Access to parameters via DP V1 is described in the *DP V1 Parameter Access* section.

5.1.4 PROFIBUS DP V0 / PCV Channel

Parameter access via the PCV channel is performed using PROFIBUS DP V0 cyclic data exchange, where the PCV channel is part of the PPOs described in the *PPO Types* section. Using the PCV channel, it is possible to read and write parameter values, as well as read a number of descriptive attributes for each parameter. The functionality of the PCV channel is described in the *PCV Parameter Access* section.

NOTE

Object and data types supported by AF-650 GP & AF-600 FP drives and common to both DP V1 and PCV parameter access are listed in the *Parameters* chapter.

5

5.2 DP V1 Parameter Access

This section is useful for the developer with some experience in:

PLC programs with PROFIBUS master class 1 functionality

PC applications with PROFIBUS master class 2 functionality

For more detailed instructions in use of the DP V1 function in AF-650 GP & AF-600 FP drives, please refer to the Instruction Manual *Information about the features supported by the PROFIBUS DP V1 functions*.

5.2.1 PROFIBUS DP V1 Introduction

The PROFIBUS DP extension DPV1 offers acyclical communication in addition to the cyclical data communication of DP V0. This feature is possible using a DP master class 1 (e.g., PLC), as well as a DP master class 2 (e.g., PC Tool).

Cyclical communication means that data transfer takes place continuously with a certain refresh rate. This is the known DP V0 function normally used for quick update of I/O process data.

Acyclical communication takes the form of a once-off data transfer event, mainly used for read / write from and to parameters from process controllers, PC-based tools or monitoring systems.

5.2.2 Features of a Master Class 1 Connection

- Cyclical data exchange (DP V0)
- Acyclical read/write from and to parameters

In general, a master class 1 is used as the process controller (either PLC or PC-based), responsible for commands, speed reference, status of the application, etc. The master class 1 acyclical connection can be used for general parameter access in the slaves. However, the acyclical connection is fixed and cannot be changed during operation.



5.2.3 Features of a Master Class 2 Connection

- Initiate / Abort acyclical connection
- Acyclical read/write from and to parameters

The master class 2 acyclical connection is typically used for configuration or commissioning tools for easy access to each parameter in any slave in the system. The acyclical connection can be dynamically established (Initiate) or removed (Abort) even when a master class 1 is active on the network.

5.2.4 Services Overview for AF-650 GP & AF-600 FP drives

Master type	Service					
	Read	Write	Data transport	Initiate	Abort	Alarm
	<i>read data from slave</i>	<i>write data to slave</i>	<i>read and write data</i>	<i>open a connection</i>	<i>close a connection</i>	
Master Class 1	yes	yes	yes	-	-	-
Master Class 2	yes	yes	yes	yes	yes	-

5

5.2.5 Principle of Data Exchange by PROFIBUS DP V1

In a DP cycle, the master class 1 (MC1) will first update the cyclical process data for all slaves in the system. The MC1 can then send one acyclical message to one slave. If a master class 2 (MC2) is connected, the MC1 will hand over the network rights to MC2, which will then be permitted to send one acyclical message to one slave. The token is then handed back to the MC1, and a new DP cycle begins.

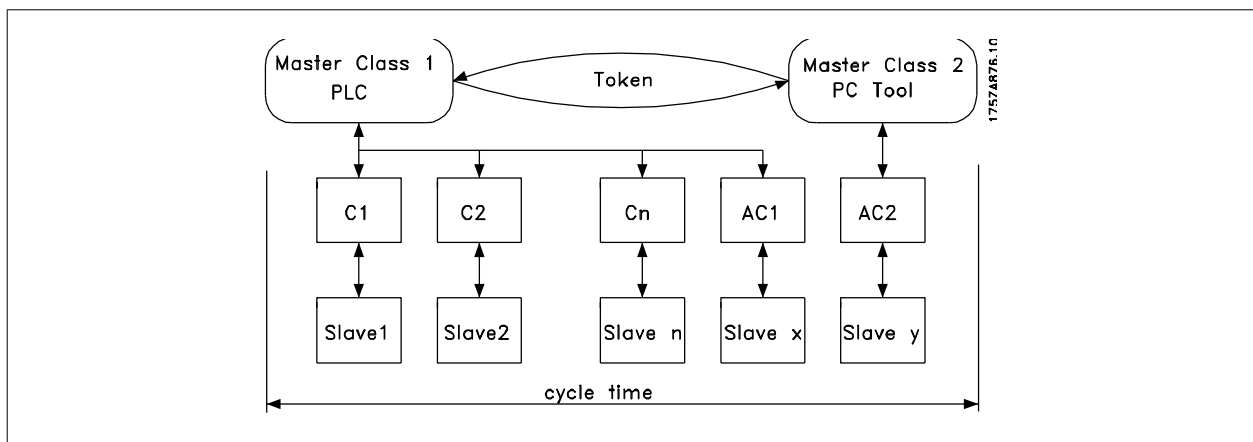

MC: Master Class

C1...Cn: Cyclical data

AC1: Acyclical data Master Class 1

AC2: Acyclical data Master Class 2



PROFIBUS DP services are activated via specific Service Access Points (SAP). For acyclical communication, the following SAP are specified:

Master SAP	Slave SAP	Meaning
50 (32H)	49 (31H)	Master Class 2: Initiate request
50 (32H)	0..48 (0..30H)	Master Class 2: Abort, Read, Write, Data transfer
51 (33H)	50, 51 (32H, 33H)	Master Class 2: Alarm
51 (33H)	51 (33H)	Master Class 2: Read, Write

5.2.6 How to Use the DP V1 Features for Parameter Access

This section describes how DP V1 can be used for accessing drive parameters.

5

For units as complex as adjustable frequency drives, the standard PROFIBUS DP V1 read and write services are not sufficient for accessing the many parameters and attributes in the drive. For this reason, the PROFIdrive Parameter Channel is defined. Using this parameter Read/Write is performed by addressing a single DP V1 object in the adjustable frequency drive in the following way:

Slot = 0

Index = 47

The message has the following general structure:

PROFIBUS Message Header	Data Unit				PROFIdrive V3.0 Parameter Channel		PROFIBUS Message	
	DP V1 Command/response				Req. / Res. Header		Trailer	
	DU	DU	DU	DU	Data			
	0	1	2	3				

The DP V1 command/response part is used for the standard DP V1 read/write on the Slot 0, Index 47 data block.

The PROFIdrive V3 Parameter Channel is used to access specific parameter data in the drive.



5.2.7 DP V1 Read / Write Services

The table below shows the content of the DP V1 command / response headers and their possible attributes.

DU Byte	Value	Meaning	Specified
0	Function number	Idle REQ, RES	
	0x48		
	0x51	Data transport REQ, RES	
	0x56	Resource Manager REQ	
	0x57	Initiate REQ, RES	
	0x58	Abort REQ	
	0x5C	Alarm REQ, RES	
	0x5E	Read REQ, RES	
	0x5F	Write REQ, RES	
	0xD1	Data transport negative response	
	0xD7	Initiate negative response	
	0xDC	Alarm negative response	
	0xDE	Read negative response	
	0xDF	Write negative response	
1	Always zero	Slot number	DPV1
2	47	Index	DPV1
3	xx	Data length	DPV1
4..n		User data	PNO Drive Profile V3.0

5.2.8 How to Use the DP V1 Acyclical Parameter Channel

The PROFIdrive Parameter Channel should be used for read and write for AF-650 GP & AF-600 FP drive parameters. The table below shows the structure of the PROFIdrive Parameter Channel. Using this it is possible to access the following drive parameter values and attributes:

- Parameter values of simple variable, array and visible string
- Parameter description elements such as type, min./max. value, etc.
- Descriptive text for parameter values
- Access to multiple parameters in one message is also possible

PROFIBUS DP V1 message for read/write from or to a drive parameter:

PROFIBUS Message Header	Data Unit								PROFIBUS Message	
	DP V1				PROFIdrive V3.0 Parameter Channel				Trailer	
	Command/response									
	DU	DU	DU	DU	Req. / Res. Header				Data	
	0	1	2	3						



The following table shows the principle structure of the PROFIdrive Parameter Channel.

The DP V1 Parameter Request message consists of 3 data blocks:

- a request header, which defines the kind of request (read or write), and the number of parameters to access. The master sets the request reference and uses this information to evaluate the response
- an address field, where all addressing attributes of the desired parameters are defined
- a data field, where all parameter data values are placed

DP V1	Parameter request	Byte no.	
Request header	Request reference	0	
	Request ID	1	
	Axis	2	
Address field	No. of parameters	3	
	Attribute	4	
	No. of elements	5	
	Parameter no.		6
			7
	Sub index		8
			9
n'th parameter no.	$4+6*(n-1)$		
	...		
Data field	Data format	$4+6*n$	
	No. of values	$(4+6*n)+1$	
	Values	$(4+6*n)+2$	
	n'th data value	...	

5

The DP V1 Parameter response message consists of 2 data blocks:

- A response header, which indicates if the request is performed without errors (response ID), the number of parameters, and the request reference set by the master within the corresponding request message
- A data field, where the requested data are placed. If one or more internal requests have failed, an error code is placed instead of the data values

DP V1	Parameter response	Byte no.
Response header	Request ref. mirrored	0
	Response ID	1
	Axis mirrored	2
Parameter Values	No. of parameters	3
	Format	4
	No. of values	5
	Values of error values	6
	n'th parameter value	...

As the response message does not include parameter addressing information, the master must identify the structure of the response data from the request message.



5.2.9 Request / Response Attributes

The table contains an overview of the possible attributes of the PROFIdrive parameter channel.

Field	Data type	Values	Remark
Request reference	Unsigned8	0x01..0xFF	
Request ID	Unsigned8	0x01 request parameter value	Identification for read or write request
		0x02 change parameter value	
		0x42 change parameter non-volatile	
		0x51 request par. value double word	
		0x52 change par. value double word	
Response ID	Unsigned8	0x01 request parameter (+) Positive	Identification for the response
		0x02 change parameter (+) Positive	
		0x81 request parameter (-) Negative	
		0x82 change parameter (-) Negative	
Axis	Unsigned8	0x00..0xFF number (always 0)	
Number of parameters	Unsigned8	0x01..0x25	Limitation: DP V1 message length
Attribute	Unsigned8	0x10 value	
		0x20 description	Data description
		0x30 text	
Number of elements	Unsigned8	0x01-0xFA Quantity 1-234	Limitation: DP V1 message length
Parameter number	Unsigned16	0x0001... number 1-65535	Parameter number
		0xFFFF	
Subindex	Unsigned16	0x0000 number 0-65535	Array pointer
		0xFFFF	
Format	Unsigned8	See table	
Number of values	Unsigned8	0x01..0xEA Quantity 0-234	Limitation: DP V1 message length
Error number	Unsigned16	0x0000... Error number	

5

5.2.10 Request Reference

Unique identification of request/response pair for the master. The master changes the request reference with each new request. The slave mirrors the request reference in the response.

5.2.11 Request ID

The following request identifications are defined:

0x01	Request parameter
0x02	Change parameter (Data are NOT stored in non-volatile memory, lost at power cycle)
0x42	Change parameter non-volatile (data are stored in non-volatile memory)
0x51	Request parameter value double word. (All parameters are formatted and transferred as double word size, regardless of the actual data type)
0x52	Change parameter value double word. (All parameters must be formatted and sent as double word size, regardless of data type)



5.2.12 Response ID

The response ID indicates if the read or write request was successfully performed in the adjustable frequency drive. If the response is negative, the request is answered negative (first bit = 1) and an error code is entered per partial response, instead of the value.

5.2.13 Axis

The axis attribute should be set to zero.

5.2.14 Number of Parameters

For multi-parameter requests specifying the number of the parameter address and/or parameter value areas. For a single request, the number is 1.

5

5.2.15 Attribute

The attribute determines which kind of data to access. The adjustable frequency drive will respond to the attributes Value (10H), Description (20H) and Text (30H).

5.2.16 Attribute Value (10H)

The attribute value permits reading or writing of parameter values.

5.2.17 Attribute Description (20H)

The attribute description permits access to the parameter description. It is possible to read out one single description element, or all elements for one parameter in one message. The table below provides an overview of the existing parameter description, which exists for each parameter in the adjustable frequency drive.

Parameter description elements (all elements are read-only):

Sub-index	Meaning	Data Type
1	Identifier ID	V2
2	Number of array elements or length or string	U16
3	Standardization factor	float
4	Variable attribute	Octet string 2
5	Reserved	Octet string 4
6	Name	Visible string 16
7	Lower limit	Octet string 4
8	Upper limit	Octet string 4
9	Reserved	Octet string 2
10	ID extension	V2
11	PCD reference parameter	U16
12	PCD normalization	V2
0	Complete description	Octet string 46

In the following, each description element is explained.

**Identifier ID**

Additional characteristics of a parameter.

Bit	Meaning
15	Reserved
14	Array
13	Parameter value can be reset only
12	Parameter has been changed from the factory setting
11	Reserved
10	Additional text array available
9	Parameter is read-only
8	Standardization factor and variable attribute not relevant
0-7	Data type

Number of Array Elements

Contains the number of array elements, if the parameter is an array; the string length, if the parameter value is a string; or 0 if the parameter is neither.

Standardization Factor

Conversion factor for scaling a given parameter value to standard SI units.

For example, if the given value is in mV, the standardization factor will be 1000, which converts the given value to V.

The standardization factor is in float format.

Variable Attribute

Consists of 2 bytes. The first byte contains the variable index, which defines the physical unit of the parameter (e.g., Ampere, Volt).

The second byte is the conversion index, which is a scaling factor for the parameter. In general, all parameters accessible by PROFIBUS are organized and transmitted as real numbers. The conversion index defines a factor for converting the actual value to a standard physical unit. (a conversion index of -1 means, that the actual value must be divided by 10 to become a standard physical unit e.g., Volt.

Name

Contains the parameter name, limited to 16 characters, e.g., LANGUAGE for K-01 *Language*. This text is available in the language selected in K-01 *Language*.

Lower Limit

Contains the minimum value of the parameter. Format is 32 bit signed.

Upper Limit

Contains the maximum value of the parameter. Format is 32 bit signed.

ID Extension

Not supported

PCD Reference Parameter

Process data may be scaled by a parameter, e.g., the max reference of 0x4000 (in %) depends on the setting of parameter "X".

To enable the master to calculate the "real" value of the process data, it has to know the value of parameter "X", and therefore the process data must deliver a reference to parameter "X".



Field PCD Normalization

The field PCD normalization must express, in any case, the value that represents the 100%, i.e., the normalization delivered back must be the set bit 15 and a value of 0xe (14, $2^{14} = 0 \times 4000$), and the result must be $0 \times 800e$.

Complete Description

Returns the complete parameter description with the fields 1 to 12 in order. Length = 46 bytes.

5.2.18 Attribute Text (30H)

For some adjustable frequency drive parameters, a descriptive text is available, which can be read using this attribute. The availability of a text description for a parameter is indicated by a bit set in the Identifier (ID) Parameter Description element, which can be read out by the Description Attribute (20H) sub-index = 1. If bit 10 is set, a descriptive text exists for each value of the parameter.

As an example, K-01 *Language* has settings from 0 to 5. For each of these values a specific text exists: 0 = ENGLISH, 2 = DEUTSCH, etc.

5.2.19 Format

Specifies the format type for each parameter (word, byte, etc.), see below.

5.2.20 Supported data types

Value	Data Type
3	Integer16
4	Integer32
5	Unsigned8
6	Unsigned16
7	Unsigned32
9	Visible string
10	Octet string (byte string)
33	N2 (standardized value)
35	V2 (bit sequence)
44	Error
54	Time difference without date indication

5.2.21 Value

The value field contains the parameter value of the request. When the response is negative, the field contains a corresponding error code. If the values consist of an odd number of bytes, a zero byte is appended in order to maintain the word structure of the messages.

For a positive partial response, the parameter value field contains the following attributes:

Format = (Data Type or Byte, Word, Double Word)

Number of values = actual number of values

Value = Parameter value

For a negative partial response, the parameter value field contains the following:

Format = error (44H)

Number of values = 1

Value = error value = error number



5.2.22 Error Number for Drive Profile V3.0

When the parameter request is invalid, the adjustable frequency drive will return a corresponding error code. The table below lists the full range of error codes.

Error codes for DP V1 parameter requests

Error code	Meaning	Additional Info
0x00	Unknown parameter	0
0x01	Parameter is read-only	sub-index
0x02	Value out of range due to max/min value	sub-index
0x03	Wrong sub-index	sub-index
0x04	Parameter is no array	0
0x05	Wrong data type (wrong data length)	0
0x06	This parameter may not be set, only reset	sub-index
0x07	Descriptive element is read-only	sub-index
0x09	No description available (only value)	0
0x0b	Process control not possible	0
0x0f	No text array available (only value)	0
0x11	Not possible in current state	0
0x14	Value out of range due to drive state/configuration	sub-index
0x15	Reply too long (more than 240 bytes)	0
0x16	Wrong parameter address (unknown or unsupported value for attribute, element, par. number or sub-index or illegal combination)	0
0x17	Illegal format (for writing)	0
0x18	Value amount not consistent	0
0x65	Wrong axis: action not possible with this axis	-
0x66	Unknown service request	-
0x67	This service is not possible with multi parameter access	-
0x68	Parameter value can not be read from network	-



5.3 PCV Parameter Access

Parameter access via the PCV channel is performed by the PROFIBUS DP V0 cyclical data exchange, where the PCV channel is part of the PPOs described in the chapter How to Control the Adjustable Frequency Drive.

5

Byte no.	PCV								PCD																			
	PCA		IND		PVA				CTW		MRV		PCD		PCD		PCD		PCD		PCD							
	1	2	3	4	5	6	7	8	9	10	11	12	13	14	15	16	17	18	19	20	21	22	23	24	25	26	27	28
Type 1:																												
Type 2:																												
Type 5:																												

PCV:	Parameter Characteristics Value
PCD:	Process Data
PCA:	Parameter Characteristics (Bytes 1, 2)
IND:	Sub index (Byte 3. Byte 4 is not used)
PVA:	Parameter value (Bytes 5 to 8)
CTW:	Control word
STW:	Status word
MRV:	Main reference value
MAV:	Main Actual Value (actual output frequency)

Using the PCV channel it is possible to read and write parameter values, as well as readout of a number of describing attributes of each parameter.

5.3.1 PCA Handling

The PCA part of PPO types 1, 2 and 5 can handle several tasks. The master can control and supervise parameters and request a response from the slave, whereas the slave can respond to a request from the master.

Requests and responses is a handshake procedure and cannot be batched, meaning that if the master sends out a read/write request, it has to wait for the response, before it sends a new request. The request or response data value will be limited to maximum 4 bytes, which implies that text strings are not transferable. For further information, please see the *Application Examples chapter*.

5.3.2 PCA - Parameter Characteristics

15	14	13	12	11	10	9	8	7	6	5	4	3	2	1	0
		RC		SMP						PNU					

- RC: Request/response characteristics (Range 0..15)
- SMP: Spontaneous Message (not supported)
- PNU: Parameter no. (Range 1..1999)



5.3.3 Request / Response Handling

The RC portion of the PCA word defines the requests that may be issued from the master to the slave as well as what other portions of the PCV (IND and PVA) are involved. The PVA portion will transmit word-size parameter values in bytes 7 and 8, while long word size values require bytes 5 to 8 (32 bits). If the response / request contains array elements, the IND will carry the array sub-index. If parameter descriptions are involved, the IND will hold the record sub-index of the parameter description.

5.3.4 RC Content

If the slave rejects a request from the master, the RC word in the PPO-read will indicate this by assuming the value 7. The fault number will be carried by bytes 7 and 8 in the PVA element.

Request	Function
0	No request
1	Request parameter value
2	Change parameter value (word)
3	Change parameter value (long word)
4	Request description element
5	Change description element
6	Request parameter value (array)
7	Change parameter value (array word)
8	Change parameter value (array long word)
9	Request number of array elements
10-15	Not used

Response	Function
0	No response
1	Transfer parameter value (word)
2	Transfer parameter value (long word)
3	Transfer description element
4	Transfer parameter value (array word)
5	Transfer parameter value (array long word)
6	Transfer number of array elements
7	Request rejected (incl. fault #, see below)
8	Not serviceable by PCV interface
9	Not used
10	Not used
11	Not used
12	Not used
13-15	Not used



Fault no.	Interpretation
0	Illegal PNU
1	Parameter value cannot be changed
2	Upper or lower limit exceeded
3	Subindex corrupted
4	No array
5	Data type false
6	Cannot be set by user (reset only)
7	Description element cannot be changed
8	IR required PPO-write not available
9	Description data not available
10	Access group
11	No parameter write access
12	Key word missing
13	Text in cyclical transmission not readable
14	Name in cyclical transmission not readable
15	Text array not available
16	PPO-write missing
17	Request temporarily rejected
18	Other fault
19	Data in cyclical transmission not readable
130	There is no network access to the parameter called
131	Data change is not possible because factory set-up has been selected

5.3.5 Example

This example shows how to use PPO type 1 to change the ramp-up time (F-07 *Accl Time 1*) to 10 seconds and to command a start and speed reference of 50%.

Adjustable frequency drive parameter settings:

O-50 *Coasting Select*: Bus

O-10 *Control Word Profile*: PROFIdrive profile

5.3.6 PCV

PCA Parameter Characteristics

PCA part (byte 1-2).

The RC part tells what the PCV part must be used for. The functions available appear from the table, see *PCA handling*.

When a parameter is to be changed, choose value 2 or 3. In this example 3 is chosen, because F-07 *Accl Time 1* covers a long word (32 bits).

F-07 *Accl Time 1* = 155 hex: In this example byte 1 and 2 are set to 3155.



IND (bytes 3-4):

Used when reading/changing parameters with sub-index, for example PB-15 *PCD Write Configuration*. In the example, bytes 3 and 4 are set to 00 Hex.

PVA (bytes 5-8):

The data value of F-07 *Accel Time 1* must be changed to 10.00 seconds. The value transmitted must be 1000, because the conversion index for F-07 *Accel Time 1* is 2. This means that the value received by the adjustable frequency drive is divided by 100, such that the adjustable frequency drive perceives 1000 as 10.00. Bytes 5-8 = 1000 = 03E8 Hex. See *Object and Data types supported*.

5.3.7 PCD

Control word (CTW) according to PROFIdrive profile:

Control words consist of 16 bits. The meaning of each bit is explained in the section Control word and Status word. The following bit pattern sets all necessary start commands:

0000 0100 0111 1111 = 047F Hex.*

0000 0100 0111 1110 = 047E Hex.*

0000 0100 0111 1111 = 047F Hex.

Quick stop: 0000 0100 0110 1111 = 046F Hex.

Stop: 0000 0100 0011 1111 = 043F Hex.

NOTE

* For restart after power-up: Bit 1 and 2 of the CTW must be set to 1 and bit 0 toggled from 0 to 1.

5.3.8 MRV

Speed reference, the data format is "Standardized value". 0 Hex = 0% and 4000 Hex = 100%.

In the example, 2000 Hex is used, corresponding to 50% of maximum frequency (F-53 *Maximum Reference*).

The whole PPO therefore has the following values in Hex:

		Byte	Value
PCV	PCA	1	31
	PCA	2	55
	IND	3	00
	IND	4	00
	PVA	5	00
	PVA	6	00
	PVA	7	03
	PVA	8	E8
PCD	CTW	9	04
	CTW	10	7F
	MRV	11	20
	MVR	12	00



The process data within the PCD part acts immediately upon the adjustable frequency drive, and can be updated from the master as quickly as possible. The PCV part is a "handshake" procedure which means that the adjustable frequency drive has to acknowledge the command, before a new one can be written.

A positive response to the above example may look like this:

		Byte	Value
PCV	PCA	1	21
	PCA	2	55
	IND	3	00
	IND	4	00
	PVA	5	00
	PVA	6	00
	PVA	7	03
	PVA	8	E8
PCD	STW	9	0F
	STW	10	07
	MAV	11	20
	MAR	12	00

5

The PCD part responds according to the state and parameterization of the adjustable frequency drive.

The PCV part responds as:

- PCA: As the request message, but here the RC part is taken from the response table, see the *PCA handling* section. In this example, RC is 2 Hex, which is a confirmation that a parameter value of the type long word (32 bit) has been transferred. IND is not used in this example.
- PVA: 03E8Hex in the PVA part tells that the value of *F-07 Accl Time 1* is 1000, which corresponds to 10.00.
- STW: 0F07 Hex means that the motor is running and there are no warnings or faults (for details see the status word table in the *Status word* section).
- MAV: 2000 Hex indicates that the output frequency is 50% of the maximum reference.

		Byte	Value
PCV	PCA	1	70
	PCA	2	00
	IND	3	00
	IND	4	00
	PVA	5	00
	PVA	6	00
	PVA	7	00
	PVA	8	02
PCD	STW	9	0F
	STW	10	07
	MAV	11	20
	MAR	12	00

A negative response may look like this:

RC is 7 Hex, which means that the request has been rejected, and the fault number can be found in the PVA part. In this case, the fault number is 2, which means that the upper or lower limit of the parameter is exceeded. See the fault number table in the *PCA handling* section.



6 Parameters

O-01 Control Site

Option:
Function:

The setting in this parameter overrides the settings in *O-50 Coasting Select* to *O-56 Preset Reference Select*.

[0] *	Digital and ctrl.word	Control by using both digital input and control word.
[1]	Digital only	Control by using digital inputs only.
[2]	Controlword only	Control by using control word only.

O-02 Control Word Source

Select the source of the control word: one of two serial interfaces or four installed options. During initial power-up, the adjustable frequency drive automatically sets this parameter to *Option A* [3] if it detects a valid network option module installed in slot A. If the option is removed, the adjustable frequency drive detects a change in the configuration, sets *O-02 Control Word Source* back to default setting *Drive RS485*, and the adjustable frequency drive then trips. If an option is installed after initial power-up, the setting of *O-02 Control Word Source* will not change but the adjustable frequency drive will trip and display: *Alarm 67 Option Changed*.

This parameter cannot be adjusted while the motor is running.

Option:
Function:

[0]	None
[1]	Drive RS485
[2]	Drive USB
[3] *	Option A
[4]	Option B
[5]	Option C0
[6]	Option C1
[30]	External Can

O-03 Control Word Time-out Time

Range:
Function:

1.0 s* [0.1 - 18000.0 s]

Enter the maximum time expected to pass between the reception of two consecutive messages. If this time is exceeded, it indicates that the serial communication has stopped. The function selected in *O-04 Control Word Time-out Function* will then be carried out. The timeout counter is triggered by a valid control word.

O-04 Control Word Time-out Function

Select the timeout function. The timeout function activates when the control word fails to be updated within the time period specified in *O-03 Control Word Time-out Time*.

Option:
Function:

[0] *	Off	Resumes control via serial bus (network or standard) using the most recent control word.
[1]	Freeze output	Freezes output frequency until communication resumes.
[2]	Stop	Stops with auto-restart when communication resumes.
[3]	Jogging	Runs the motor at JOG frequency until communication resumes.
[4]	Max. speed	Runs the motor at maximum frequency until communication resumes.



[5]	Stop and trip	Stops the motor, then resets the adjustable frequency drive in order to restart: via the network, via the reset button on the Keypad or via a digital input.
[7]	Select set-up 1	Changes the set-up upon reestablishment of communication following a control word timeout. If communication resumes causing the timeout situation to disappear, <i>O-05 End-of-Time-out Function</i> defines whether to resume the set-up used before the timeout or to retain the set-up endorsed by the timeout function.
[8]	Select set-up 2	See [7] <i>Select set-up 1</i>
[9]	Select set-up 3	See [7] <i>Select set-up 1</i>
[10]	Select set-up 4	See [7] <i>Select set-up 1</i>

[26]

NOTE

The following configuration is required in order to change the set-up after a timeout:

Set *K-10 Active Set-up* to [9] *Multi set-up* and select the relevant link in *K-12 This Set-up Linked to*.

6

O-05 End-of-Time-out Function**Option:****Function:**

		Select the action after receiving a valid control word following a timeout. This parameter is active only when <i>O-04 Control Word Time-out Function</i> is set to [Set-up 1-4].
[0]	Hold set-up	Retains the set-up selected in <i>O-04 Control Word Time-out Function</i> and displays a warning, until <i>O-06 Reset Control Word Time-out</i> toggles. Then the adjustable frequency drive resumes its original set-up.
[1] *	Resume set-up	Resumes the set-up active prior to the timeout.

O-06 Reset Control Word Time-out

This parameter is active only when *Hold set-up* [0] has been selected in *O-05 End-of-Time-out Function*.

Option:**Function:**

[0] *	Do not reset	Retains the set-up specified in <i>O-04 Control Word Time-out Function</i> , following a control word timeout.
[1]	Do reset	Returns the adjustable frequency drive to the original set-up following a control word timeout. The adjustable frequency drive performs the reset and then immediately reverts to the <i>Do not reset</i> [0] setting

O-07 Diagnosis Trigger**Option:****Function:**

		Enables and controls the drive diagnostics function.
[0] *	Disable	Extended diagnostics data are not sent even if they appear in the adjustable frequency drive.
[1]	Trigger on alarms	Extended diagnostics data are sent when one or more alarms appear.
[2]	Trigger alarm/warn.	Extended diagnostics data are sent if one or more alarms/warnings appear.

O-10 Control Word Profile

Select the interpretation of the control and status words corresponding to the installed serial communication bus. Only the selections valid for the serial communication bus installed in slot A will be visible in the Keypad display.

For guidelines in selection of *GE Drive profile* [0] and *PROFdrive profile* [1] please refer to the *Serial communication via RS 485 Interface* section.

For additional guidelines in selecting the *PROFdrive profile* [1] and *ODVA* [5], please refer to the Instruction Manual for the installed serial communication bus.

**Option:****Function:**

[0] * Drive Profile

[1] PROFdrive profile

[5] ODVA

O-50 Coasting Select**Option:****Function:**

Select control of the coasting function via the terminals (digital input) and/or via the network.

[0] Digit Input

[1] Bus

[2] Logic AND

[3] * Logic OR

NOTEThis parameter is active only when O-01 Control Site is set to [0] *Digital and control word*.**O-51 Quick Stop Select**

Select control of the quick stop function via the terminals (digital input) and/or via the network.

Option:**Function:**

[0] Digital Input

[1] Bus

[2] Logic AND

[3] * Logic OR

NOTEThis parameter is active only when O-01 Control Site is set to [0] *Digital and control word*.**O-52 DC Brake Select****Option:****Function:**

Select control of the DC brake via the terminals (digital input) and/or via the network.

[0] Digit Input

[1] Bus

[2] Logic AND

[3] * Logic OR

NOTEThis parameter is active only when O-01 Control Site is set to [0] *Digital and control word*.

**O-53 Start Select**

Option:	Function:
	Select control of the adjustable frequency drive start function via the terminals (digital input) and/or via the network.
[0] Digit Input	Activates Start command via a digital input.
[1] Bus	Activates the start command via the serial communication port or network option module.
[2] Logic AND	Activates the start command via the network/serial communication port, AND additionally via one of the digital inputs.
[3] * Logic OR	Activates the start command via the network/serial communication port OR via one of the digital inputs.

NOTE

This parameter is active only when O-01 Control Site is set to [0] *Digital and control word*.

6**O-54 Reversing Select**

Option:	Function:
	Select control of the adjustable frequency drive reverse function via the terminals (digital input) and/or via the network.
[0] Digital Input	Activates the reverse command via a digital input.
[1] Bus	Activates the reverse command via the serial communication port or network option module.
[2] Logic AND	Activates the reverse command via the network/serial communication port, AND additionally via one of the digital inputs.
[3] * Logic OR	Activates the reverse command via the network/serial communication port OR via one of the digital inputs.

NOTE

This parameter is only active when O-01 Control Site is set to [0] *Digital and control word*.

O-55 Set-up Select

Option:	Function:
	Select control of the adjustable frequency drive set-up selection via the terminals (digital input) and/or via the network.
[0] Digit Input	Activates the set-up selection via a digital input.
[1] Bus	Activates the set-up selection via the serial communication port or network option module.
[2] Logic AND	Activates the set-up selection via the network/serial communication port, AND additionally via one of the digital inputs.
[3] * Logic OR	Activate the set-up selection via the network/serial communication port OR via one of the digital inputs.

NOTE

This parameter is active only when O-01 Control Site is set to [0] *Digital and control word*.

**O-56 Preset Reference Select****Option:****Function:**

Select control of the adjustable frequency drive Preset Reference selection via the terminals (digital input) and/or via the network.

[0] Digit Input

Activates Preset Reference selection via a digital input.

[1] Bus

Activates Preset Reference selection via the serial communication port or network option module.

[2] Logic AND

Activates Preset Reference selection via the network/serial communication port, AND additionally via one of the digital inputs.

[3] * Logic OR

Activates the Preset Reference selection via the network/serial communication port OR via one of the digital inputs.

NOTE

This parameter is active only when O-01 *Control Site* is set to [0] *Digital and control word*.

O-90 Bus Jog 1 Speed**Range:**

100 RPM* [0 - par. F-17 RPM]

Function:

Enter the jog speed. This is a fixed jog speed activated via the serial port or network option.

O-91 Bus Jog 2 Speed**Range:**

200 RPM* [0 - par. F-17 RPM]

Function:

Enter the jog speed. This is a fixed jog speed activated via the serial port or network option.

PB-15 PCD Write Configuration

Array [10]

Option:**Function:**

Select the parameters to be assigned to PCDs 3 to 10 of the messages. The number of available PCDs depends on the message type. The values in PCDs 3 to 10 will then be written to the selected parameters as data values. Alternatively, specify a standard Profibus message in PB-22 *Telegram Selection*.

PB-16 PCD Read Configuration

Array [10]

Option:**Function:**

Select the parameters to be assigned to PCDs 3 to 10 of the messages. The number of available PCDs depends on the message type. PCDs 3 to 10 contain the actual data values of the selected parameters. For standard Profibus message, see PB-22 *Telegram Selection*.

PB-18 Node Address**Range:**

126 * [0 - 126.]

Function:

Enter the station address in this parameter, or alternatively in the hardware switch. In order to adjust the station address in PB-18 *Node Address*, the hardware switch must be set to 126 or 127 (i.e. all switches set to 'on'). Otherwise, this parameter will display the actual setting of the switch.

**PB-22 Telegram Selection****Option:****Function:**

Select a standard Profibus message configuration for the adjustable frequency drive as an alternative to using the freely configurable messages in PB-15 *PCD Write Configuration* and PB-16 *PCD Read Configuration*.

[1] Standard telegram 1

[101] PPO 1

[102] PPO 2

[103] PPO 3

[104] PPO 4

[105] PPO 5

[106] PPO 6

[107] PPO 7

[108] * PPO 8

[200] Custom telegram 1

PB-23 Parameters for Signals

Array [1000]

Read only

Option:**Function:**

This parameter contains a list of signals available for selection in PB-15 *PCD Write Configuration* and PB-16 *PCD Read Configuration*.

PB-27 Parameter Edit**Option:****Function:**

Parameters can be edited via Profibus, the standard RS485 interface, or the Keypad.

[0] Disabled

Disables editing via Profibus.

[1] * Enabled

Enables editing via Profibus.

PB-28 Process Control**Option:****Function:**

Process control (setting of control word, speed reference and process data) is possible via either Profibus or standard serial communication bus, but not both simultaneously. Local control is always possible via the Keypad. Control via process control is possible via either terminals or serial communication bus depending on the settings in O-50 *Coasting Select* to O-56 *Preset Reference Select*.

[0] Disable

Disables process control via Profibus, and enables process control via standard serial communication bus or Profibus Master class 2.

[1] * Enable cyclic master

Enables process control via Profibus Master Class 1, and disables process control via standard serial communication bus or Profibus Master class 2.

**PB-53 Profibus Warning Word****Range:**

0 * [0 - 65535]

Function:This parameter displays Profibus communication warnings. Please refer to the *Profibus Instruction Manual* for further information.

Read only

Bit:	Meaning:
0	Connection with DP master is not ok
1	Not used
2	FDL (Fieldbus [or Serial Communication Bus] Link Layer) is not ok
3	Clear data command received
4	Actual value is not updated
5	Baudrate search
6	PROFIBUS ASIC is not transmitting
7	Initializing of PROFIBUS is not ok
8	The adjustable frequency drive is tripped.
9	Internal CAN error
10	Wrong configuration data from PLC
11	Wrong ID sent by PLC
12	Internal error occurred
13	Not configured
14	Timeout active
15	Warning 34 active

PB-63 Actual Baud Rate**Option:**

[0] 9.6 kbit/s

[1] 19.2 kbit/s

[2] 93.75 kbit/s

[3] 187.5 kbit/s

[4] 500 kbit/s

[6] 1500 kbit/s

[7] 3000 kbit/s

[8] 6000 kbit/s

[9] 12000 kbit/s

[10] 31.25 kbit/s

[11] 45.45 kbit/s

[255] * No baud rate found

Function:

This parameter displays the actual Profibus baud rate. The Profibus Master automatically sets the baud rate.

PB-64 Device Identification**Range:**

0 * [0 - 0]

Function:

This parameter displays the device identification.

PB-65 Profile Number**Range:**

0 * [0 - 0]

Function:

This parameter contains the profile identification. Byte 1 contains the profile number, and byte 2 the version number of the profile.

**NOTE**

This parameter is not visible via Keypad.

PB-70 Edit Set-up

Option:	Function:
	Select the set-up to be edited.
[0] Factory set-up	Uses default data. This option can be used as a data source to return the other set-ups to a known state.
[1] Set-up 1	Edits Set-up 1.
[2] Set-up 2	Edits Set-up 2.
[3] Set-up 3	Edits Set-up 3.
[4] Set-up 4	Edits Set-up 4.
[9] * Active Set-up	Follows the active set-up selected in K-10 <i>Active Set-up</i> .

This parameter is unique to Keypad and serial communication busses. See also K-11 *Edit Set-up*.

PB-71 Profibus Save Data Values

Option:	Function:
	Parameter values changed via Profibus are not automatically stored in non-volatile memory. Use this parameter to activate a function that stores parameter values in the EEPROM non-volatile memory, so that changed parameter values will be retained at power-down.
[0] * Off	Deactivates the non-volatile storage function.
[1] Store all set-ups	Stores all parameter values in the set-up selected in PB-70 <i>Edit Set-up</i> in the non-volatile memory. The selection returns to Off [0] when all values have been stored.
[2] Store all set-ups	Stores all parameter values for all set-ups in the non-volatile memory. The selection returns to Off [0] when all parameter values have been stored.

PB-72 ProfibusDriveReset

Option:	Function:
[0] * No action	
[1] Power-on reset	Resets the adjustable frequency drive upon power-up, as for power-cycle.
[3] Comm option reset	Resets the Profibus option only, useful after changing certain settings in parameter group PB-##, e.g., PB-18 <i>Node Address</i> . When reset, the adjustable frequency drive disappears from the network, which may cause a communication error from the master.

PB-80 Defined Parameters (1)

Array [116]

No Keypad access

Read only

Range:	Function:
0 * [0 - 9999]	This parameter displays a list of all the defined adjustable frequency drive parameters available for Profibus.

**PB-81 Defined Parameters (2)**

Array [116]

No Keypad access

Read only

Range:

0 * [0 - 9999]

Function:

This parameter displays a list of all the defined adjustable frequency drive parameters available for Profibus.

PB-82 Defined Parameters (3)

Array [116]

No Keypad access

Read only

Range:

0 * [0 - 9999]

Function:

This parameter displays a list of all the defined adjustable frequency drive parameters available for Profibus.

PB-83 Defined Parameters (4)

Array [116]

No Keypad access

Read only

Range:

0 * [0 - 9999]

Function:

This parameter displays a list of all the defined adjustable frequency drive parameters available for Profibus.

PB-90 Changed Parameters (1)

Array [116]

No Keypad access

Read only

Range:

0 * [0 - 9999]

Function:

This parameter displays a list of all the adjustable frequency drive parameters deviating from default setting.

PB-91 Changed Parameters (2)

Array [116]

No Keypad access

Read only

Range:

0 * [0 - 9999]

Function:

This parameter displays a list of all the adjustable frequency drive parameters deviating from default setting.

PB-92 Changed Parameters (3)

Array [116]

No Keypad access

Read only

Range:

0 * [0 - 9999]

Function:

This parameter displays a list of all the adjustable frequency drive parameters deviating from default setting.

**PB-94 Changed Parameters (5)**

Array [116]

No Keypad Address

Read only

Range:

0 * [0 - 9999]

Function:

This parameter displays a list of all the adjustable frequency drive parameters deviating from default setting.

DR-84 Comm. Option STW**Range:**

0 * [0 - 65535]

Function:**DR-90 Alarm Word****Range:**

0 * [0 - 4294967295]

Function:

View the alarm word sent via the serial communication port in hex code.

6**DR-92 Warning Word****Range:**

0 * [0 - 4294967295]

Function:

View the warning word sent via the serial communication port in hex code.



6.3 PROFIBUS-specific Parameter List

Parameter	Default value	Range	Conversion index	Data type
O-01 Control Site	Dig. & ctrl. word [0]	[0 - 2]	-	Uint8
O-02 Control Word Source	Drive RS485 [0]	[0 - 4]	-	Uint8
O-03 Control Word Time-out Time	1	0.1-18000	-1	Uint32
O-04 Control Word Time-out Function	Off [0]	[0 - 10]	-	Uint8
O-05 End-of-Time-out Function	Hold set-up [0]	[0 - 1]	-	Uint8
O-06 Reset Control Word Time-out	Do not reset [0]	[0 - 1]	-	Uint8
O-07 Diagnosis Trigger	Disable [0]	[0 - 3]	-	Uint8
O-10 Control Word Profile	GE Drive profile [0]	[0 - x]	-	Uint8
O-50 Coasting Select	*Logic OR [3]	[0 - 3]	-	Uint8
O-51 Quick Stop Select	*Logic OR [3]	[0 - 3]	-	Uint8
O-52 DC Brake Select	*Logic OR [3]	[0 - 3]	-	Uint8
O-53 Start Select	*Logic OR [3]	[0 - 3]	-	Uint8
O-54 Reversing Select	*Logic OR [3]	[0 - 3]	-	Uint8
O-55 Set-up Select	*Logic OR [3]	[0 - 3]	-	Uint8
O-56 Preset Reference Select	*Logic OR [3]	[0 - 3]	-	Uint8
O-90 Bus Jog 1 Speed	100 rpm	0 - par. F-17	67	Uint16
O-91 Bus Jog 2 Speed	200 rpm	0 - par. F-17	67	Uint16
PB-15 PCD Write Configuration	-	-	-	Uint16
PB-16 PCD Read Configuration	-	-	-	Uint16
PB-18 Node Address	126	1 - 126	0	Uint8
PB-22 Telegram Selection	-	[0 - 108]	-	Uint8
PB-23 Parameters for Signals	-	0 - 573	-	Uint16
PB-27 Parameter Edit	Enabled [1]	[0 - 1]	-	Uint16
PB-28 Process Control	Enable cyclic master [1]	[0 - 1]	-	Uint16
PB-44 Fault Message Counter	0	[0 - 8]	0	Uint16
PB-45 Fault Code	0	-	-	Uint16
PB-47 Fault Number	0	-	-	Uint16
PB-52 Fault Situation Counter	0	0 - 1000	0	Uint16
PB-53 Profibus Warning Word	0	16 bits	0	V2
PB-63 Actual Baud Rate	No baud rate found [255]	9,6-12000 kbits	0	Uint8
PB-64 Device Identification	0	[0 - 10]	0	Uint16
PB-65 Profile Number	0	8 bits	0	Uint8
PB-70 Edit Set-up	Active set-up [9]	[0 - 9]	-	Uint8
PB-71 Profibus Save Data Values	Off [0]	[0 - 2]	-	Uint8
PB-72 ProfibusDriveReset	No action [0]	[0 - 2]	-	Uint8
PB-80 Defined Parameters (1)	-	0-115	0	Uint16
PB-81 Defined Parameters (2)	-	0-115	0	Uint16
PB-82 Defined Parameters (3)	-	0-115	0	Uint16
PB-83 Defined Parameters (4)	-	0-115	0	Uint16
PB-90 Changed Parameters (1)	-	0-115	0	Uint16
PB-91 Changed Parameters (2)	-	0-115	0	Uint16
null Changed Parameters (3)	-	0-115	0	Uint16
PB-93 Changed parameters (4)	-	0-115	0	Uint16
DR-84 Comm. Option STW	0	0 - FFFF	0	V2
DR-90 Alarm Word	0	0 - FFFF	0	Uint32
DR-92 Warning Word	0	0 - FFFF	0	Uint32

Please refer to the relevant Instruction Manual for a comprehensive parameter list.



6.4 Object and Data Types Supported

6.4.1 Parameter and Data Type Structure Description

6.4.2 Parameter Description

PROFIBUS DP has a number of describing attributes. Read/write on parameter description is performed in the PCV part using the RC commands 4/5 and the sub-index of the desired description element.

6.4.3 Size Attribute

The size index and the conversion index for each parameter can be taken from the parameter list in the respective Instruction Manual.

6

Physical unit	Size index	Measuring unit	Designation	Conversion index	Conversion factor
	0	No dimension			
Time	4	second	s	0	1
		millisecond	ms	-1	0.1
		minute	min	-2	0.01
		hour	h	-3	0.001
		day	d	70	60
Energy	8	watt hour	Wh	74	3600
		kilowatt hour	kWh	77	86400
		megawatt hour	MWh		
Power	9	milliwatt	mW	0	1
		watt	W	-3	0.001
		kilowatt	kW	0	1
		megawatt	MW	3	1000
Rotation	11	rotation per minute	RPM	6	10 ⁶
Torque	16	newton meter	Nm	0	1
		kilonewton meter	kNm	3	1000
Temperature	17	degree Celsius	°C	0	1
Voltage	21	millivolt	mV	-3	0.001
		volt	V	0	1
		kilovolt	kV	3	1000
Current	22	milliampere	mA	-3	0.001
		ampere	A	0	1
		kiloampere	kA	3	1000
Resistance	23	milliohm	mOhm	-3	0.001
		ohm	Ohm	0	1
		kiloohm	kOhm	3	1000
Ratio	24	per cent	%	0	1
Relative change	27	per cent	%	0	1
Frequency	28	hertz	Hz	0	1
		kilohertz	kHz	3	1000
		megahertz	MHz	6	10 ⁶
		gigahertz	GHz	9	10 ⁹



6.4.4 Object and Data Types Supported

Data types supported

Data type	Short name	Description
3	I2	Integer 16
4	I4	Integer 32
5	-	Unsigned 8
6	O2	Unsigned 16
7	O4	Unsigned 32
9	-	Visible string
10	-	Byte string
33	N2	Standardized value (16 bit)
35	V2	Bit sequence
54	-	Time difference without date indication

6

6.4.5 Standardized Value

The frequency reference value is transmitted to the adjustable frequency drive in the form of a 16-bit word. The value is transmitted in integers (0-32767). The value 16384 (4000 Hex) corresponds to 100%. Negative numbers are formed with the aid of the twos complement.

0% = 0 (0h), 100% is 2^{14} (4000h)

Data type	N2
Range	-200%...+200%
Resolution	$2^{-14} = 0.0061\%$
Length	2 bytes

Notation: 2s complement notation.

MSB is 1st bit after sign bit in 1st byte.

Sign bit = 0 = positive number

Sign bit = 1 = negative number

Bit	8	7	6	5	4	3	2	1
Byte 1	SIGN	2^{14}	2^{13}	2^{12}	2^{11}	2^{10}	2^9	2
Byte 2	2^7	2^6	2^5	24	2^3	2^2	2^1	2^0

Bit sequence

16 Boolean values for control and presentation of user functions.

Notation is binary

Bit	8	7	6	5	4	3	2	1
Byte 1	15	14	13	12	11	10	9	8
Byte 2	7	6	5	4	3	2	1	0





7 Application Examples

7.1 E.g.: Process Data with PPO Type 6

This example shows how to work with PPO type 6, which consists of Control Word/Status Word and Reference/Main Actual Value. The PPO also has two additional words, which can be programmed to monitor process signals:

	PCV							PCD																				
	PCA	IND	PVA				1	2	3	4	5	6	7	8	9	10												
Byte no.	1	2	3	4	5	6	7	8	9	10	11	12	13	14	15	16	17	18	19	20	21	22	23	24	25	26	27	28
Type 6:									CTW	STW	MRV	MAV	PCD	PCD	PCD	PCD	PCD	PCD	PCD	PCD	PCD	PCD	PCD	PCD	PCD	PCD	PCD	PCD

The application requires monitoring of the motor torque and digital input, so PCD 3 is set up to read the current motor torque. PCD 4 is set up to monitor the state of an external sensor via the process signal digital input. The sensor is connected to digital input 18.

An external device is also controlled via control word bit 11 and the built-in relay of the adjustable frequency drive. Reversing is permitted only when the reversing bit 15 in the control word and the digital input 19 are set to high.

For safety reasons, the adjustable frequency drive will stop the motor if the PROFIBUS cable is broken, the master has a system failure, or the PLC is in stop mode.

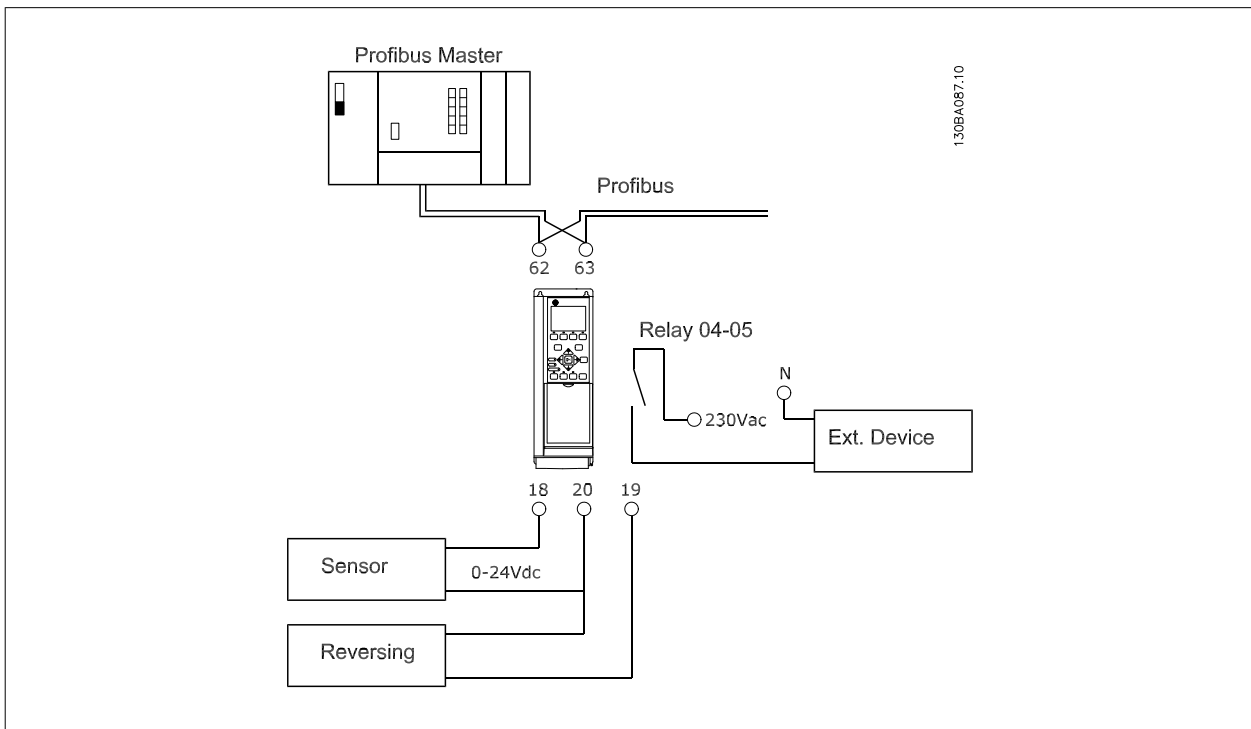



Program the adjustable frequency drive as follows:

Parameter	Setting
H-08 Reverse Lock	Both directions [2]
E-01 Terminal 18 Digital Input	No operation [0]
E-02 Terminal 19 Digital Input	Reversing [10]
E-24 Function Relay	Control word bit 11/12 [36/37]
O-03 Control Word Time-out Time	1 sec
O-04 Control Word Time-out Function	Stop [2]
O-10 Control Word Profile	GE Drive Profile [0]
O-50 Coasting Select	Network [1]
O-51 Quick Stop Select	Network [1]
O-52 DC Brake Select	Network [1]
O-53 Start Select	Network [1]
O-54 Reversing Select	Logic AND [2]
O-55 Set-up Select	Network [1]
O-56 Preset Reference Select	Network [1]
PB-16 PCD Read Configuration	Sub-index [2] DR-16 Torque [Nm] Sub-index [3] DR-60 Digital Input
PB-18 Node Address	Set the address



7.2 E.g.: Control Word Network using PPO Type

This example shows how the control word network relates to the PLC and the adjustable frequency drive, using Ge Drive Control Profile.

The control word network is sent from the PLC to the adjustable frequency drive. PPO Type 3 is used in the example in order to demonstrate the full range of modules. All the values shown are arbitrary and are provided for the purposes of demonstration only.

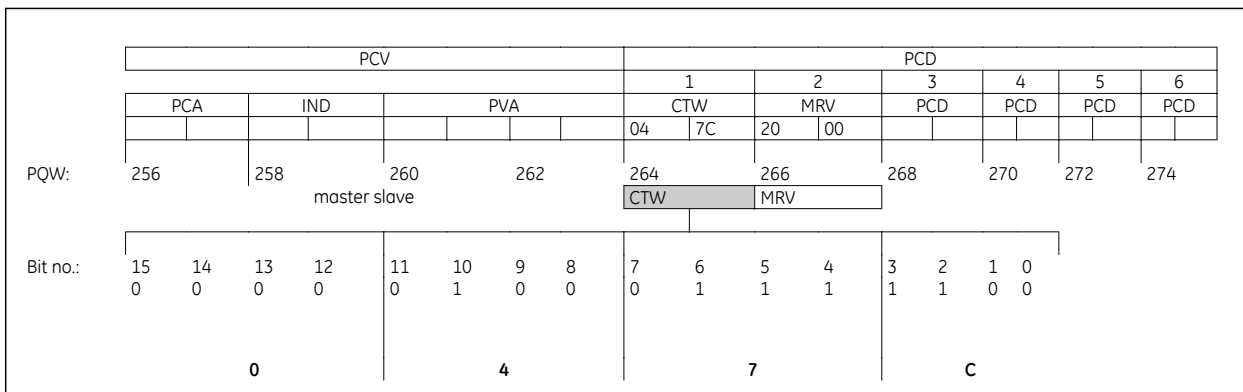

The table above indicates the bits contained within the control word and how they are presented as process data in PPO type 3 for this example.

The following table indicates which bit functions, and which corresponding bit values are active for this example.

Bit	Bit value = 0	Bit value = 1	Bit value
00	Reference value	External selection lsb	0
01	Reference value	External selection msb	0
02	DC brake	Accel/Decel	1
03	Coasting	Enable	1
04	Quick stop	Accel/Decel	1
05	Freeze output	Accel/Decel enable	1
06	Accel/Decel stop	Start	1
07	No function	Reset	0
08	No function	Jog	0
09	Accel/Decel 1	Accel/Decel 2	0
10	Data not valid	Valid	1
11	No function	Relay 01 active	0
12	No function	Relay 02 active	0
13	Parameter set-up	Selection lsb	0
14	Parameter set-up	Selection msb	0
15	No function	Reversing	0

Function active	<input type="checkbox"/>
Function inactive	<input type="checkbox"/>



7.3 E.g.: Status Word Network using PPO Type

This example shows how the control word network relates to the PLC and the adjustable frequency drive, using GE Drive Control Profile.

The control word network is sent from the PLC to the adjustable frequency drive. PPO Type 3 is used in the example in order to demonstrate the full range of modules. All the values shown are arbitrary and are provided for the purposes of demonstration only.

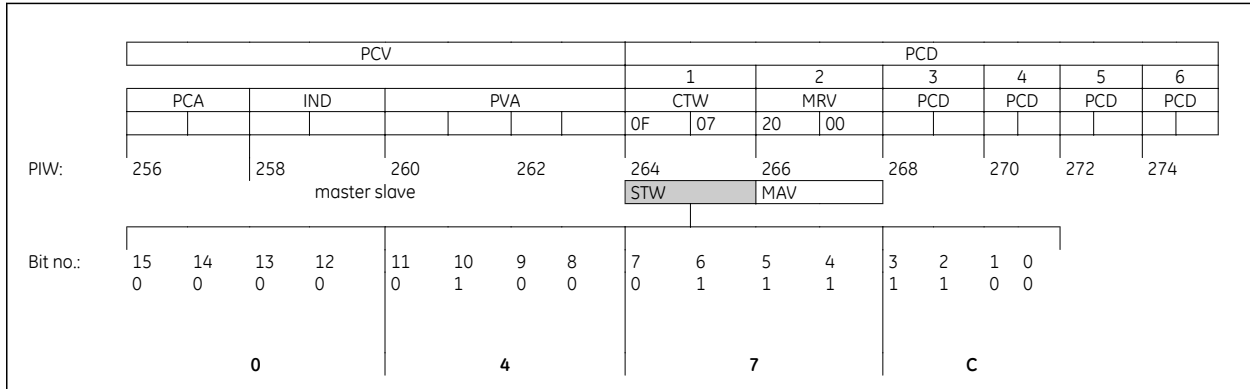

7

The table above indicates the bits contained within the status word, and how they are presented as process data in PPO type 3 for this example.

The following table indicates which bit functions, and which corresponding bit values are active for this example.

Bit	Bit value = 0	Bit value = 1	Bit value	
00	Control not ready	Control ready	1	7
01	Drive not ready	Drive ready	1	
02	Coasting	Enable	1	
03	No error	Trip	0	0
04	No error	Error (no trip)	0	
05	Reserved	-	0	
06	No error	Triplock	0	
07	No warning	Warning	0	F
08	Speed reference	Speed = reference	1	
09	Local operation	Network control	1	
10	Outside frequency ranges	Within frequency ranges	1	
11	No operation	In operation	1	0
12	Drive ok	Stopped, autostart	0	
13	Voltage ok	Voltage exceeded	0	
14	Torque ok	Torque exceeded	0	
15	Timers ok	Timers exceeded	0	
Function active		<input type="checkbox"/>		
Function inactive		<input type="checkbox"/>		



7.4 E.g.: PLC Programming

In this example PPO type 6 is placed in the following Input/Output address:

Slot	D...	Order Number / Designation	I Address	Q Address	Comment
1	115	PPO Type 6 Word consistent PCD	256...263	256...263	
2					

130BA111.10

Input address	256-257	258-259	260-261	262-263	Output address	256-257	258-259	260-261	262-263
Set-up	Status word	MAV	Motor torque	Digital input	Set-up	Control word	Reference	Not used	Not used

This network will send a start command (047C Hex) and a reference (2000 Hex) of 50% to the frequency converter.

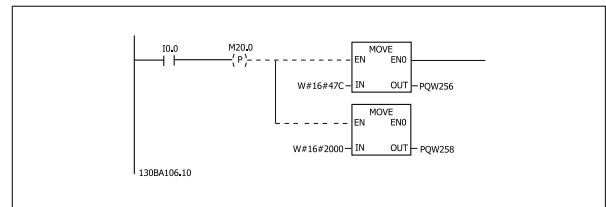

This network reads the motor torque from the frequency converter. A new reference will be sent to the frequency converter because the Motor Torque (86.0%) is higher than the compared value.

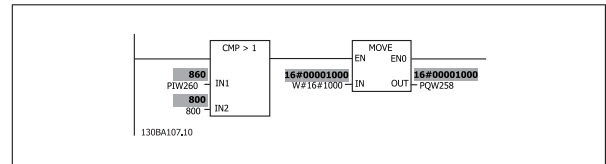

This network reads the status on the digital inputs from the frequency converter. If digital input 18 is On it will stop the frequency converter.

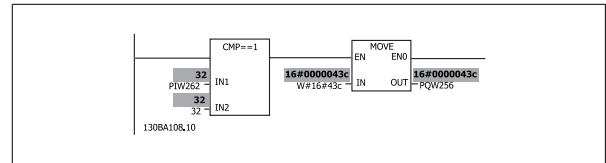

This network will reverse the motor when digital input 19 is ON, because O-54 Reversing Select is programmed to Logic AND.

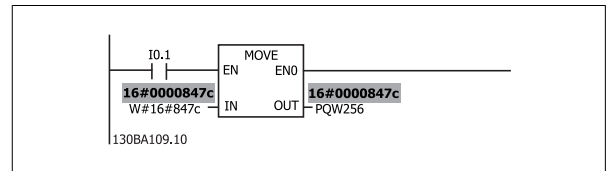

This network will activate the relay 02.

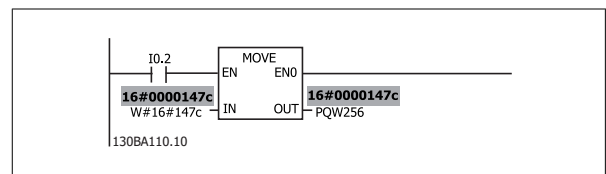





8 Troubleshooting

8.1 Diagnostics

PROFIBUS-DP provides a flexible means of performing diagnostics of slave units, based on diagnostics messages.

During normal cyclical data exchange, the slave can set a diagnostics bit, which requests the master to send a diagnostics message during the next scan cycle, instead of the normal data exchange.

The slave then answers the master with a diagnostics message consisting of standard diagnostics information, 6 bytes, and possibly extended, vendor specific, diagnostics information. The standard diagnostics messages covers a rather limited range of general diagnostics possibilities, whereas the extended diagnostics function offers very detailed messaging specific to the adjustable frequency drive.

The extended diagnostics messages for the adjustable frequency drive can be found in the section *Warning word, extended status word and alarm word*. A master or a network analyzing tool will be able to translate these diagnostics words into real text messages using the GSD file.

NOTE
DP V1 diagnostics is supported for Profibus SW version 2 and later versions. This means that the default setting of the Profibus option is DP V1 diagnostics. If DP V0 diagnostics is required, the setting under *DP slave Properties* must be changed.

8.2 Troubleshooting

8.2.1 LED Status

First, check the LEDs. The two bi-color LEDs on the PROFIBUS module indicate the status of PROFIBUS communication. The lower LED indicates the Net status, i.e., the cyclical communication to the PROFIBUS master. The upper LED indicates the module status, i.e., acyclical DP V1 communication from either a PROFIBUS Master Class 1 (PLC) or a Master Class 2 (DCT-10).

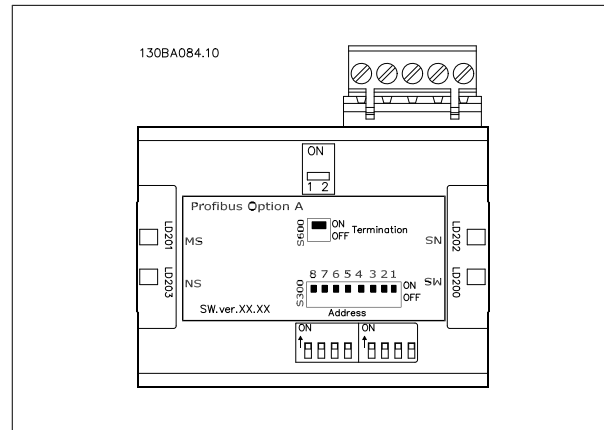



Phases	Bi-color LED	Status
Power On	Red	The PROFIBUS card is defect. Contact GE or your local distributor
	Green	The PROFIBUS card is OK.
Search baud rate	Green	Searching for the baud rate. Check the connection to the master if it stays in this state.
Wait Parameterizing	Green	Baud rate found - waiting for parameters from the master.
	Red	Wrong parameters from the master.
Wait Configuration	Green	Parameters from master OK - waiting for configuration data.
	Red	Wrong configuration data from the master.
Data Exchange	Green	Data exchange between the master and the adjustable frequency drive is active.
	Red	Clear State. Warning 34 is active and a network reaction in O-04 Control Word Time-out Function is executed.

8.1: LED 1: Net Status

Bi-color LED	Status
No light	No PROFIBUS DPV1 communication is active.
Green	DP V1 communication from a Master Class 1 (PLC) is active.
Green	DP V1 communication from a Master Class 2 (DCT-10) is active.
Green	DP V1 communication from a Master Class 1 and 2 is active.
Red	Internal error.

8.2: LED 2: Module Status

8.2.2 No Communication with the Drive

If there is no communication with the drive, proceed with the following checks:

Check 1: Is the cabling correct?

Check that the red and green cables are connected to the correct terminals as shown in the diagram below. If the cables are crossed, no communication is possible.

- 62 = RxD/TxD-P red cable
- 63 = RxD/TxD-N green cable

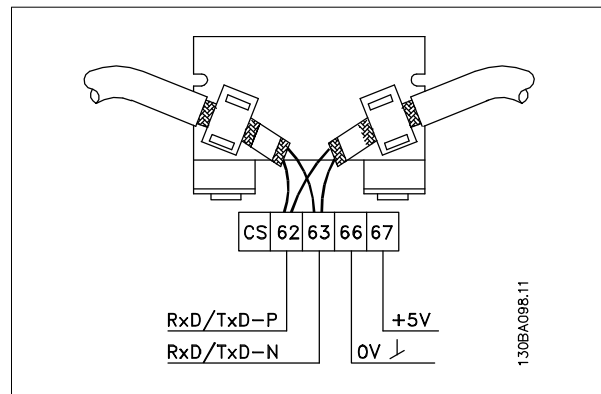



Check 2: Is the correct GSD file installed?

Download the correct GSD file from www.geelectrical.com/drives.

ID-61 Option SW Version	GSD File
1.x	GEAF6SeriesV2-X.GSD
2.x	GEAF6SeriesV2-X.GSD

Check 3: Is the network connection terminated at both ends?

If not, terminate the network connection with termination resistors at the initial and final nodes, as shown in the following diagram.

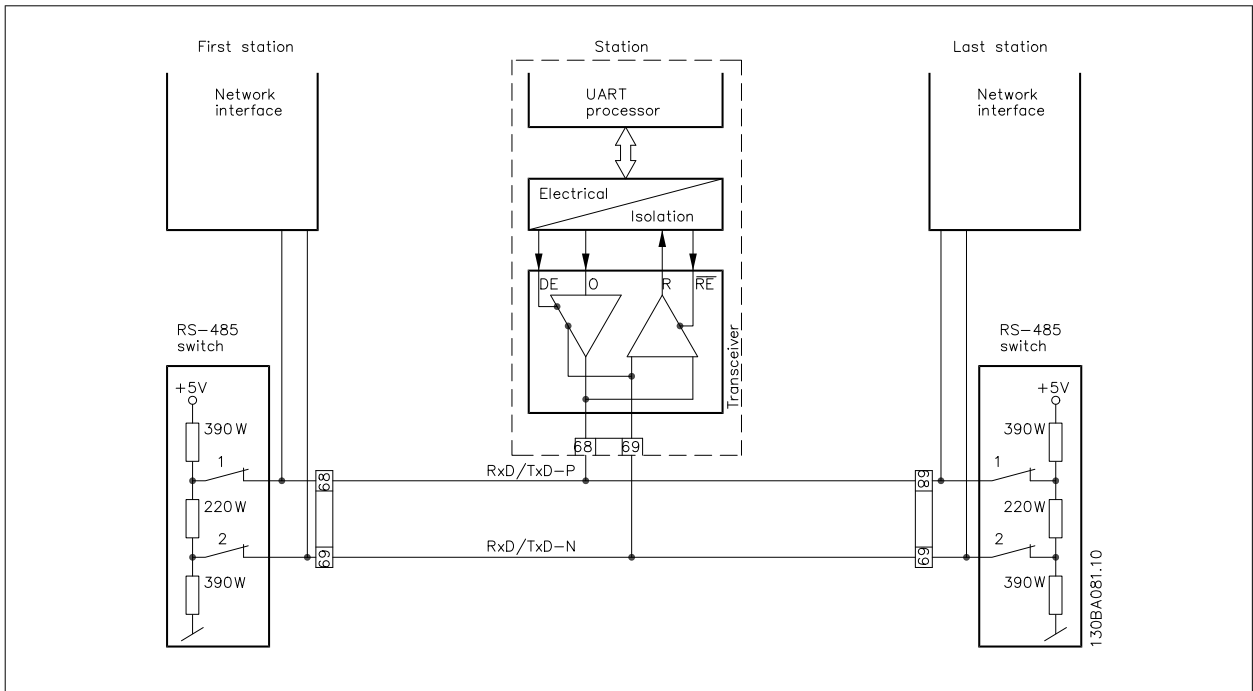

8.2.3 Warning 34 Appears even though Communication is Established

If the PLC is in stop mode Warning 34 will appear. Check that the PLC is in run mode.

8.2.4 Drive Will Not Respond to Control Signals

Check 1: Is the control word valid?

If bit 10=0 in the control word, then the drive will not accept the control word, because the default setting is bit 10=1. Set bit 10=1 via the PLC.

Check 2: Is the relationship between bits in the control word and the terminal I/Os correct?

Check the logical relationship in the drive.

Set the logic to bit 3=1 AND digital input=1 in order to achieve a successful start.

Define the desired logical relationship in O-50 Coasting Select to O-56 Preset Reference Select according to the following range of options. Select the drive control mode, digital input and/or serial communication, using O-50 Coasting Select to O-56 Preset Reference Select.



The tables below show the effect upon the adjustable frequency drive of a coast command for the full range of O-50 *Coasting Select* settings.

The effect of control mode upon the function of O-50 *Coasting Select*, O-51 *Quick Stop Select* and O-52 *DC Brake Select* is as follows:

If *Digital input* [0] is selected, the terminals will control the coast and DC brake functions.

NOTE
Please note that coasting, quick stop and DC brake functions are active for logic 0.

Digital input [0]		
Terminal	Bit 02/03/04	Function
0	0	Coast/DC brake/Q-Stop
0	1	Coast/DC brake/Q-Stop
1	0	No Coast/DC brake/Q-Stop
1	1	No Coast/DC brake/Q-Stop

If *Serial communication* [1] is selected, commands will be activated only when given via serial communication.

Serial communication [1]		
Terminal	Bit 02/03/04	Function
0	0	Coast/DC brake/Q-Stop
0	1	No Coast/DC brake/Q-Stop
1	0	Coast/DC brake/Q-Stop
1	1	No Coast/DC brake/Q-Stop

If *Logic AND* [2] is selected, both signals must be activated to perform the function.

Logic AND [2]		
Terminal	Bit 02/03/04	Function
0	0	Coast/DC brake/Q-Stop
0	1	No Coast/DC brake/Q-Stop
1	0	No Coast/DC brake/Q-Stop
1	1	No Coast/DC brake/Q-Stop

If *Logic OR* [3] is selected, activation of one signal will activate the function.

Logic OR [3]		
Terminal	Bit 02/03/04	Function
0	0	Coast/DC brake/Q-Stop
0	1	Coast/DC brake/Q-Stop
1	0	Coast/DC brake/Q-Stop
1	1	No Coast/DC brake/Q-Stop

The effect of control mode upon the function of O-53 *Start Select* and O-54 *Reversing Select*:

If *Digital input* [0] is selected, the terminals will control the start and reversing functions

Digital input [0]		
Terminal	Bit 06/15	Function
0	0	Stop/counter-clockwise
0	1	Stop/counter-clockwise
1	0	Start/Clockwise
1	1	Start/Clockwise

If *Serial communication* [1] is selected, commands will be activated only when given via serial communication.

Serial communication [1]		
Terminal	Bit 02/03/04	Function
0	0	Stop/counter-clockwise
0	1	Start/Clockwise
1	0	Stop/counter-clockwise
1	1	Start/Clockwise

If *Logic AND* [2] is selected, both signals must be activated to perform the function.

Logic AND [2]		
Terminal	Bit 02/03/04	Function
0	0	Stop/counter-clockwise
0	1	Stop/counter-clockwise
1	0	Stop/counter-clockwise
1	1	Start/Clockwise



If *Logic OR* [3] is selected, activation of one signal will activate the function.

Logic OR [3]		
Terminal	Bit 02/03/04	Function
0	0	Stop/counter-clockwise
0	1	Start/Clockwise
1	0	Start/Clockwise
1	1	Start/Clockwise

The effect of control mode upon the function of *O-55 Set-up Select* and *O-56 Preset Reference Select*:

If *Digital input* [0] is selected, the terminals will control the set-up and pre-set reference functions.

Digital input [0]				
Terminal		Bit 00/01, 13/14		Function
Msb	Lsb	Msb	Lsb	Preset ref., Set-up no.
0	0	0	0	1
0	0	0	1	1
0	0	1	0	1
0	0	1	1	1
0	1	0	0	2
0	1	0	1	2
0	1	1	0	2
0	1	1	1	2
1	0	0	0	3
1	0	0	1	3
1	0	1	0	3
1	0	1	1	3
1	1	0	0	4
1	1	0	1	4
1	1	1	0	4
1	1	1	1	4

If *Serial communication* [1] is selected, commands will be activated only when given via serial communication.

Serial communication [1]				
Terminal		Bit 00/01, 13/14		Function
Msb	Lsb	Msb	Lsb	Preset ref., Set-up no.
0	0	0	0	1
0	0	0	1	2
0	0	1	0	3
0	0	1	1	4
0	1	0	0	1
0	1	0	1	2
0	1	1	0	3
0	1	1	1	4
1	0	0	0	1
1	0	0	1	2
1	0	1	0	3
1	0	1	1	4
1	1	0	0	1
1	1	0	1	2
1	1	1	0	3
1	1	1	1	4

If *Logic AND* [2] is selected, both signals must be activated to perform the function.

Logic AND [2]				
Terminal		Bit 00/01, 13/14		Function
Msb	Lsb	Msb	Lsb	Preset ref., Set-up no.
0	0	0	0	1
0	0	0	1	1
0	0	1	0	1
0	0	1	1	1
0	1	0	0	1
0	1	0	1	2
0	1	1	0	1
0	1	1	1	2
1	0	0	0	1
1	0	0	1	1
1	0	1	0	3
1	0	1	1	3
1	1	0	0	1
1	1	0	1	2
1	1	1	0	3
1	1	1	1	4



If Logic OR [3] is selected, activation of one signal will activate the function.

Logic OR [3]				
Terminal		Bit 00/01, 13/14		Function
Msb	Lsb	Msb	Lsb	Preset ref., Set-up no.
0	0	0	0	1
0	0	0	1	2
0	0	1	0	3
0	0	1	1	4
0	1	0	0	2
0	1	0	1	2
0	1	1	0	4
0	1	1	1	4
1	0	0	0	3
1	0	0	1	4
1	0	1	0	3
1	0	1	1	4
1	1	0	0	4
1	1	0	1	4
1	1	1	0	4

8.2.5 Alarm and Warning Words

Alarm word, Warning word and PROFIBUS warning word are shown on the display in Hex format. If there is more than one warning or alarm, a sum of all warnings or alarms will be shown. Alarm word, warning word and PROFIBUS warning word can also be displayed using the serial network in DR-90 Alarm Word, DR-92 Warning Word and PB-53 Profibus Warning Word.

8

AF-650 GP & AF-600 FP			
Bit (Hex)	Unit diagnose bit	Alarm word (DR-90 Alarm Word)	Alarm no.
00000001	48	Brake check	28
00000002	49	Power card overtemperature	29
00000004	50	Ground fault	14
00000008	51	Control card overtemperature	65
00000010	52	Control word timeout	18
00000020	53	Overcurrent	13
00000040	54	Torque limit	12
00000080	55	Motor thermistor overtemp.	11
00000100	40	Motor Electronic Overload overtemperature	10
00000200	41	Drive overloaded	9
00000400	42	DC link undervoltage	8
00000800	43	DC link overvoltage	7
00001000	44	Short circuit	16
00002000	45	Soft-charge fault	33
00004000	46	Line phase loss	4
00008000	47	Auto Tune not OK	50
00010000	32	Live zero error	2
00020000	33	Internal fault	38
00040000	34	Brake overload	26
00080000	35	Motor phase U is missing	30
00100000	36	Motor phase V is missing	31
00200000	37	Motor phase W is missing	32
00400000	38	Network comm. fault	34
00800000	39	24 V supply fault	47
01000000	24	Line failure	36
02000000	25	1.8 V supply fault	48
04000000	26	Brake resistor short circuit	25
08000000	27	Brake chopper fault	27
10000000	28	Option change	67
20000000	29	Drive Initialized	80
40000000	30	Safe stop	68
80000000	31	Mechanical brake low	63

AF-650 GP & AF-600 FP			
Bit (Hex)	Unit diagnose bit	Warning word (DR-92 Warning Word)	Alarm no.
00000001	112	Brake check	28
00000002	113	Power card overtemperature	29
00000004	114	Ground fault	14
00000008	115	Control card	65
00000010	116	Control word timeout	18
00000020	117	Overcurrent	13
00000040	118	Torque limit	12
00000080	119	Motor thermistor overtemp.	11
00000100	104	Motor Electronic Overload overtemperature	10
00000200	105	Drive overloaded	9
00000400	106	DC link undervoltage	8
00000800	107	DC link overvoltage	7
00001000	108	DC link voltage low	6
00002000	109	DC link voltage high	5
00004000	110	Line phase loss	4
00008000	111	No motor	3
00010000	96	Live zero error	2
00020000	97	10 V low	1
00040000	98	Brake overload	26
00080000	99	Brake resistor short circuit	25
00100000	100	Brake chopper fault	27
00200000	101	Speed limit	49
00400000	102	Network comm. fault	34
00800000	103	24 V supply fault	47
01000000	88	Line failure	36
02000000	89	Current limit	59
04000000	90	Low temperature	66
08000000	91	Voltage limit	64
10000000	92	Encoder loss	61
20000000	93	Output frequency limit	62
40000000	94	Unused	-
80000000	95	Warning word 2 (ext. stat. word)	-



AF-650 GP & AF-600 FP		
Bit (Hex)	Unit diagnosis bit	PROFIBUS warning word (PB-53 Profibus Warning Word)
00000001	160	Connection with DP master is not ok
00000002	161	Unused
00000004	162	NDL (Network Data link Layer) is not ok
00000008	163	Clear data command received
00000010	164	Actual value is not updated
00000020	165	Baudrate search
00000040	166	PROFIBUS ASIC is not transmitting
00000080	167	Initializing of PROFIBUS is not ok
00000100	152	Drive is tripped
00000200	153	Internal CAN error
00000400	154	Wrong configuration data from PLC
00000800	155	Wrong ID sent by PLC
00001000	156	Internal error occurred
00002000	157	Not configured
00004000	158	Timeout active
00008000	159	Warning 34 active

AF-650 GP & AF-600 FP	
Bit (Hex)	Comm. option STW (DR-84 Comm. Option STW)
00000001	parameters ok
00000002	configuration ok
00000004	clearmode active
00000008	baudrate search
00000010	waiting for parameterization
00000020	waiting for configuration
00000040	in data exchange
00000080	not used
00000100	not used
00000200	not used
00000400	not used
00000800	MCL2/1 connected
00001000	MCL2/2 connected
00002000	MCL2/3 connected
00004000	data transport active
00008000	not used

NOTE

DR-84 Comm. Option STW is not part of extended diagnostics.

8.2.6 Warning and Alarm Messages

There is a clear distinction between alarms and warnings. When there is an alarm, the adjustable frequency drive will enter a fault condition. After the cause for the alarm has been cleared, the master will have to acknowledge the alarm message before the adjustable frequency drive can start operating again. A warning, on the other hand, may come when a warning condition appears, then disappear when conditions return to normal, without interfering with the process.

Warnings

Warnings within the adjustable frequency drive are represented by a single bit within a warning word. A warning word is always an active parameter. Bit status FALSE [0] means no warning, while bit status TRUE [1] means warning. Any bit change in the warning word will be notified by a change of bit 7 in the status word.

Alarms

Following an alarm message the adjustable frequency drive will enter fault condition. Only after the fault has been alleviated and the master has acknowledged the alarm message by setting bit 7 in the control word, will the adjustable frequency drive resume operation. Alarms within the adjustable frequency drive are represented by a single bit within an alarm word. An alarm word is always an action parameter. Bit status FALSE [0] means no fault, while bit status TRUE [1] means fault.

8.2.7 Fault Messages via DP Diagnostics

The standard DP function features an on-line diagnostics, which is active during DP initialization as well as data exchange mode.

8.2.8 Extended Diagnostics

Using the extended diagnostics function, alarm and warning information can be received from the adjustable frequency drive. The setting of O-07 *Diagnosis Trigger* determines which adjustable frequency drive events should trigger the extended diagnostics function.

When O-07 *Diagnosis Trigger* is set to Disable [0], no extended diagnostics data are sent regardless of whether they appear in the adjustable frequency drive.



When O-07 *Diagnosis Trigger* is set to Alarms [1], extended diagnostics data are sent when one or more alarms arrive in the alarm DR-90 *Alarm Word* or PB-53 *Profibus Warning Word*.

When O-06 *Reset Control Word Time-out* is set to Alarms/Warnings [2], extended diagnostics data are sent if one or more alarms/warnings arrive in the alarm DR-90 *Alarm Word* or PB-53 *Profibus Warning Word*, or in the warning DR-92 *Warning Word*.

The extended diagnostics sequence is as follows: If an alarm or warning appears, the adjustable frequency drive will indicate that to the master by sending a high priority message via the output data message. This will cause the master to send a request for extended diagnostics information to the adjustable frequency drive, to which the adjustable frequency drive will reply. When the alarm or warning disappears, the adjustable frequency drive will again indicate that to the master, and on the following request from the master, return a standard DP diagnostics frame (6 bytes).

The content of the extended diagnostics frame is as follows:

Byte	Bit no.	Name
0 to 5		Standard DP Diagnostics data
6		PDU length
7	0-7	Status type =0x81
8	8-15	Slot = 0
9	16-23	Status Information
10	24-31	DR-90 <i>Alarm Word</i>
11	32-39	DR-90 <i>Alarm Word</i>
12	40-47	DR-90 <i>Alarm Word</i>
13	48-55	DR-90 <i>Alarm Word</i>
14	56-63	Reserved for future use
15	64-71	Reserved for future use
16	72-79	Reserved for future use
17	80-87	Reserved for future use
18	88-95	DR-92 <i>Warning Word</i>
19	96-103	DR-92 <i>Warning Word</i>
20	104-111	DR-92 <i>Warning Word</i>
21	112-119	DR-92 <i>Warning Word</i>
22	120-127	Reserved for future use
23	128-135	Reserved for future use
24	136-143	Reserved for future use
25	144-151	Reserved for future use
26	152-159	PB-53 <i>Profibus Warning Word</i>
27	160-167	PB-53 <i>Profibus Warning Word</i>
28	168-175	Reserved for future use
29	176-183	Reserved for future use
30	184-191	Reserved for future use
31	192-199	Reserved for future use



9 Warnings and Alarms

9.1 Status Messages

9.1.1 Warnings/Alarm Messages

A warning or an alarm is signaled by the relevant LED on the front of the adjustable frequency drive, indicated by a code on the display.

A warning remains active until its cause is no longer present. Under certain circumstances, operation of the motor may still be continued. Warning messages may be critical, but are not necessarily so.

In the event of an alarm, the adjustable frequency drive will have tripped. Alarms must be reset to restart operation once their cause has been rectified.

This may be done in three ways:

1. By using the [RESET] control button on the Keypad control panel.
2. Via a digital input with the "Reset" function.
3. Via serial communication/optional network.

NOTE

After a manual reset using the [RESET] button on the Keypad, the [AUTO] button must be pressed to restart the motor.

If an alarm cannot be reset, the reason may be that its cause has not been rectified, or the alarm is trip-locked (see also table on following page).

Alarms that are trip-locked offer additional protection, meaning that the line power supply must be switched off before the alarm can be reset. After being switched back on, the adjustable frequency drive is no longer blocked and may be reset as described above, once the cause has been rectified.

Alarms that are not trip-locked can also be reset using the automatic reset function in *H-04 Auto-Reset (Times)* (Warning: automatic wake-up is possible!)

If a warning and alarm are marked against a code in the table on the following page, this means that either a warning occurs before an alarm, or that you can specify whether it is a warning or an alarm that is to be displayed for a given fault.

This is possible, for instance, in *F-10 Electronic Overload*. After an alarm or trip, the motor carries on coasting, and the alarm and warning flash. Once the problem has been rectified, only the alarm continues flashing until the adjustable frequency drive is reset.



9.1.2 Alarm List

No.	Description	Warning	Alarm/Trip	Alarm/Trip Lock	Parameter Reference
1	10 Volts low	X			
2	Live zero error	(X)	(X)		AN-01 <i>Live Zero Time-out Function</i>
3	No motor	(X)			H-80 <i>Function at Stop</i>
4	Line phase loss	(X)	(X)	(X)	SP-12 <i>Function at Mains Imbalance</i>
5	DC link voltage high	X			
6	DC link voltage low	X			
7	DC overvoltage	X	X		
8	DC undervoltage	X	X		
9	Inverter overloaded	X	X		
10	Motor Electronic OL overtemperature	(X)	(X)		F-10 <i>Electronic Overload</i>
11	Motor thermistor overtemperature	(X)	(X)		F-10 <i>Electronic Overload</i>
12	Torque limit	X	X		
13	Overcurrent	X	X	X	
14	Ground Fault	X	X	X	
15	Hardware mismatch		X	X	
16	Short Circuit		X	X	
17	Control word timeout	(X)	(X)		O-04 <i>Control Word Time-out Function</i>
22	Hoist Mech. Brake				
23	Internal Fan Fault	X			
24	External Fan Fault	X			SP-53 <i>Fan Monitor</i>
25	Brake resistor short-circuited	X			
26	Brake resistor power limit	(X)	(X)		B-13 <i>Braking Thermal Overload</i>
27	Brake chopper short-circuited	X	X		
28	Brake check	(X)	(X)		B-15 <i>Brake Check</i>
29	Heatsink temp	X	X	X	
30	Motor phase U missing	(X)	(X)	(X)	H-78 <i>Missing Motor Phase Function</i>
31	Motor phase V missing	(X)	(X)	(X)	H-78 <i>Missing Motor Phase Function</i>
32	Motor phase W missing	(X)	(X)	(X)	H-78 <i>Missing Motor Phase Function</i>
33	Soft-charge fault		X	X	
34	Network communication fault	X	X		
36	Line failure	X	X		
38	Internal Fault		X	X	
39	Heatsink sensor		X	X	
40	Overload of Digital Output Terminal 27	(X)			E-00 <i>Digital I/O Mode, E-51 Terminal 27 Mode</i>
41	Overload of Digital Output Terminal 29	(X)			E-00 <i>Digital I/O Mode, E-52 Terminal 29 Mode</i>
42	Overload of Digital Output On X30/6	(X)			E-56 <i>Term X30/6 Digi Out (OPCGPIO)</i>
42	Overload of Digital Output On X30/7	(X)			E-57 <i>Term X30/7 Digi Out (OPCGPIO)</i>
46	Pwr. card supply		X	X	
47	24 V supply low	X	X	X	
48	1.8 V supply low		X	X	
49	Speed limit	X			
50	Auto Tune calibration failed		X		
51	Auto Tune check U_{nom} and I_{nom}		X		
52	Auto Tune low I_{nom}		X		
53	Auto Tune motor too big		X		
54	Auto Tune motor too small		X		
55	Auto Tune parameter out of range		X		
56	Auto Tune interrupted by user		X		
57	Auto Tune timeout		X		
58	Auto Tune internal fault	X	X		
59	Current limit	X			
61	Tracking Error	(X)	(X)		H-20 <i>Motor Feedback Loss Function</i>
62	Output Frequency at Maximum Limit	X			
63	Mechanical Brake Low		(X)		B-20 <i>Release Brake Current</i>
64	Voltage Limit	X			
65	Control Board Overtemperature	X	X	X	



No.	Description	Warning	Alarm/Trip	Alarm/Trip Lock	Parameter Reference
66	Heatsink Temperature Low	X			
67	Option Module Configuration has Changed		X		
68	Safe Stop	(X)	(X) ¹⁾		E-07 Terminal 37 Safe Stop
69	Pwr. Card Temp		X	X	
70	Illegal Drive configuration			X	
71	Safe Stop	X	X ¹⁾		E-07 Terminal 37 Safe Stop
72	Dangerous Failure			X ¹⁾	E-07 Terminal 37 Safe Stop
73	Safe Stop Auto Restart				
77	Reduced power mode	X			SP-59 Actual Number of Inverter Units
79	Illegal PS config		X	X	
80	Drive Restored to Factory Settings		X		
81	CSIV corrupt				
82	CSIV parameter error				
85	Profibus/Profisafe Error				
90	Encoder Loss	(X)	(X)		EC-61 Feedback Signal Monitoring S202
91	Analog input 54 wrong settings			X	
243	Brake IGBT	X	X		
244	Heatsink temp	X	X	X	
245	Heatsink sensor		X	X	
246	Pwr.card supply		X	X	
247	Pwr.card temp		X	X	
248	Illegal PS config		X	X	
250	New spare part			X	
251	New Model Number		X	X	

9.1: Alarm/Warning code list

(X) Dependent on parameter

1) Cannot be auto-reset via H-04 Auto-Reset (Times)

A trip is the action taken when an alarm has occurred. The trip will coast the motor and can be reset by pressing the reset button or make a reset by a digital input (Par. E-1# [1]). The origin event that caused an alarm cannot damage the adjustable frequency drive or cause dangerous conditions. A trip lock is an action when an alarm occurs, which may cause damage to adjustable frequency drive or connected parts. A trip lock situation can only be reset by a power cycling.

LED indication	
Warning	yellow
Alarm	flashing red
Trip-locked	yellow and red



Alarm Word Extended Status Word							
Bit	Hex	Dec	Alarm Word	Alarm Word 2	Warning Word	Warning Word 2	Extended Status Word
0	00000001	1	Brake Check	ServiceTrip, Read/Write	Brake Check		Ramping
1	00000002	2	Pwr. Card Temp	ServiceTrip, (reserved)	Pwr. Card Temp		Auto Tune Running
2	00000004	4	Ground Fault	ServiceTrip, Type-code/Sparepart	Ground Fault		Start CW/CCW
3	00000008	8	Ctrl.Card Temp	ServiceTrip, (reserved)	Ctrl.Card Temp		Slow Down
4	00000010	16	Ctrl. Word TO	ServiceTrip, (reserved)	Ctrl. Word TO		Catch Up
5	00000020	32	Overcurrent		Overcurrent		Feedback High
6	00000040	64	Torque Limit		Torque Limit		Feedback Low
7	00000080	128	Motor Th Over		Motor Th Over		Output Current High
8	00000100	256	Motor Electronic OL Over		Motor Electronic OL Over		Output Current Low
9	00000200	512	Drive Overld.		Drive Overld.		Output Freq High
10	00000400	1024	DC Undervolt		DC Undervolt		Output Freq Low
11	00000800	2048	DC Overvolt		DC Overvolt		Brake Check OK
12	00001000	4096	Short Circuit		DC Voltage Low		Braking Max
13	00002000	8192	Soft-charge fault		DC Voltage High		Braking
14	00004000	16384	Line ph. Loss		Line ph. Loss		Out of Speed Range
15	00008000	32768	Auto Tune Not OK		No Motor		OVC Active
16	00010000	65536	Live Zero Error		Live Zero Error		AC Brake
17	00020000	131072	Internal Fault	KTY error	10 V Low	KTY Warn	Password Timelock
18	00040000	262144	Brake Overload	Fans error	Brake Overload	Fans Warn	Password Protection
19	00080000	524288	U-phase Loss	ECB error	Brake Resistor	ECB Warn	
20	00100000	1048576	V-phase Loss		Brake IGBT		
21	00200000	2097152	W-phase Loss		Speed Limit		
22	00400000	4194304	Network Fault		Network Fault		Unused
23	00800000	8388608	24 V Supply Low		24 V Supply Low		Unused
24	01000000	16777216	Line Failure		Line Failure		Unused
25	02000000	33554432	1.8 V Supply Low		Current Limit		Unused
26	04000000	67108864	Brake Resistor		Low Temp		Unused
27	08000000	134217728	Brake IGBT		Voltage Limit		Unused
28	10000000	268435456	Option Change		Encoder loss		Unused
29	20000000	536870912	Drive Restored to factory settings		Output freq. lim.		Unused
30	40000000	1073741824	Safe Stop (A68)	Safe Stop (A71)	Safe Stop (W68)	Safe Stop (W71)	Unused
31	80000000	2147483648	Mech. brake low	Dangerous Failure (A72)	Extended Status Word		Unused

9.2: Description of Alarm Word, Warning Word and Extended Status Word

The alarm words, warning words and extended status words can be read out via serial bus or optional network for diagnosis. See also DR-94 Ext. Status Word.



Index

A

Abbreviations	1-6
Actual Baud Rate PB-63	6-7
Alarm Messages	9-1
Alarm Word	8-6
Alarm Word DR-90	6-10
Axis	5-8

B

Bus Jog 1 Speed O-90	6-5
Bus Jog 2 Speed O-91	6-5

C

Cable Lengths And Number Of Codes	2-1
Cable Routing	2-3
Changed Parameters (1) PB-90	6-9
Changed Parameters (2) PB-91	6-9
Changed Parameters (3) PB-92	6-9
Changed Parameters (5) PB-94	6-10
Coasting Select O-50	6-3
Comm. Option Stw DR-84	6-10
Complete Description	5-10
Configuration	6-1
Connecting The Network	2-3
Connection Of The Cable Shield	2-2
Control Profile	4-5
Control Site O-01	6-1
Control Word According To Drive Profile (ctw)	4-11
Control Word According To Profidrive Profile (ctw)	4-6
Control Word Source O-02	6-1
Control Word Time-out Function O-04	6-1
Control Word Time-out Time O-03	6-1

D

Data Exchange By Profibus Dp V1	5-3
Data Store	5-1
Data Types Supported	6-13
Dc Brake Select O-52	6-3
Dct 10 Drive Control Tool Software	1-3
Defined Parameters (1) PB-80	6-8
Defined Parameters (2) PB-81	6-9
Defined Parameters (3) PB-82	6-9
Defined Parameters (4) PB-83	6-9
Device Identification PB-64	6-7
Diagnosis Trigger O-07	6-2
Diagnostics	8-1
Dp V1 Features For Parameter Access	5-4
Dp V1 Read / Write Services	5-5
Drive Parameters	3-4
Drive Will Not Respond To Control Signals	8-3

E

Edit Set-up PB-70	6-8
Emc Precautions	2-2
End-of-time-out Function O-05	6-2
Error Number For Drive Profile V3.0	5-11
Extended Diagnostics	8-7

**F**

Fault Messages Via Dp Diagnostics	8-7
Field Pcd Normalization	5-10
Freeze/unfreeze	4-15

G

Ground Connection	2-2
Gsd File	3-2

I

Id Extension	5-9
Identifier Id	5-9
Influence Of The Digital Input Terminals Upon Drive Control Mode	4-5

L

Led Status	8-1
Leds	3-5
Lower Limit	5-9

M

Master Class 1 Connection	5-2
Master Class 2 Connection	5-3
Mrv	5-15

N

Name	5-9
Network Topology	1-4
No Communication With The Drive	8-2
Node Address PB-18	6-5
Number Of Array Elements	5-9
Number Of Parameters	5-8

P

Parameter Access	5-1
Parameter Edit PB-27	6-6
Pca - Parameter Characteristics	5-12
Pca Handling	5-12
Pcd	5-15
Pcd Reference Parameter	5-9
Pcv	5-14
Pcv Parameter Access	5-12
Ppo Types	4-1
Preset Reference Select O-56	6-5
Process Control PB-28	6-6
Process Control Data	4-3
Process Control Operation	4-5
Process Data	4-3
Process Status Data	4-3
Profibus Save Data Values PB-71	6-8
Profibus Warning Word PB-53	6-7
Profibusdrivereset PB-72	6-8
Profidrive State - Transition Diagram	4-10
Profile Number PB-65	6-7

Q

Quick Stop Select O-51	6-3
------------------------	-----

**R**

Rc Content	5-13
Read / Write In Double Word Format	5-1
Reference Handling	4-3
Request / Response Attributes	5-7
Request / Response Handling	5-13
Request Id	5-7
Reset Control Word Time-out O-06	6-2
Response Id	5-8
Reversing Select O-54	6-4

S

Safety Note	1-1
Services Overview	5-3
Setting The Profibus Address	3-1
Set-up Select O-55	6-4
Size Attribute	6-12
Start Select O-53	6-4
Status Word According To Profidrive Profile (stw)	4-8
Sync/unsync	4-15

T

Telegram Selection PB-22	6-6
--------------------------	-----

U

Upper Limit	5-9
-------------	-----

V

Value	5-10
Variable Attribute	5-9

W

Warning 34	8-3
Warning Word	8-6
Warning Word DR-92	6-10
Warnings	9-1

The instructions do not claim to cover every single detail or variation in the equipment nor do they provide for every possible contingency in connection with installation, operation or maintenance. Should further information be desired or should particular problems arise which are not covered sufficiently for the purchaser's purposes, the matter should be referred to the GE company

AF-650 GP and AF-600 FP are trademarks of the General Electric Company.

GE
41 Woodford Avenue
Plainville, CT 06062

www.geelectrical.com/drives



imagination at work

130R0137



DET-624