

GE Consumer & Industrial
Electrical Distribution

AF-600 FP & AF-650 GP™ DeviceNet

Operating Instructions



imagination at work



Contents

1 Introduction	3
Safety Note	4
Assumptions	6
Hardware	6
Background Knowledge	6
Abbreviations	6
2 How to Install	7
Cabling	7
Installation of the DeviceNet option module	10
3 How to Configure the System	11
Configure the Master	13
Configure the Frequency Converter	13
4 How to Control the Frequency Converter	15
DeviceNet Process Control Modes	15
I/O Assembly Instances	16
Process Data	16
ODVA Control Profile	17
GE Drive Control Profile	20
5 How to Access the Parameters	27
Explicit Messages	27
Object Classes	27
DeviceNet Object Classes	27
Drive Object Classes	35
6 Parameters	37
Parameter List	44
Data Types Supported	45
7 Application Examples	47
Example: Working with Instance 101/151 Process	47
8 Troubleshooting	49
Troubleshooting	49
Index	56





1 Introduction

1

1.1.1 Copyright, Limitation of Liability and Revision Rights

This publication contains information proprietary to GE. By accepting and using this manual the user agrees that the information contained herein will be used solely for operating equipment from GE or equipment from other vendors provided that such equipment is intended for communication with GE equipment over a PROFIBUS serial communication link. This publication is protected under the Copyright laws.

GE does not warrant that a software program produced according to the guidelines provided in this manual will function properly in every physical, hardware or software environment.

Although GE has tested and reviewed the documentation within this manual, GE makes no warranty or representation, either express or implied, with respect to this documentation, including its quality, performance, or fitness for a particular purpose.

In no event shall GE be liable for direct, indirect, special, incidental, or consequential damages arising out of the use, or the inability to use information contained in this manual, even if advised of the possibility of such damages. In particular, GE is not responsible for any costs including but not limited to those incurred as a result of lost profits or revenue, loss or damage of equipment, loss of computer programs, loss of data, the costs to substitute these, or any claims by third parties.

GE reserves the right to revise this publication at any time and to make changes in its contents without prior notice or any obligation to notify previous users of such revisions or changes.

It has been assumed that all devices will be sitting behind a firewall that does packet filtering and the environment has well-implemented restrictions on the software that can run inside the firewall. All nodes are assumed to be "trusted" nodes.



1.2.1 Safety Note



The voltage of the frequency converter is dangerous whenever connected to mains. Incorrect installation of the motor, frequency converter or network may cause damage to the equipment, serious personal injury or death. Consequently, the instructions in this manual, as well as national and local rules and safety regulations, must be complied with.

1.2.2 Safety Regulations

1. The frequency converter must be disconnected from mains if repair work is to be carried out. Check that the mains supply has been disconnected and that the necessary time has passed before removing motor and mains plugs.
2. The [OFF] key on the control panel of the frequency converter does not disconnect the equipment from mains and is thus not to be used as a safety switch.
3. Correct protective earthing of the equipment must be established, the user must be protected against supply voltage, and the motor must be protected against overload in accordance with applicable national and local regulations.
3. Correct protective earthing of the equipment must be established, the user must be protected against supply voltage, and the motor must be protected against overload in accordance with applicable national and local regulations.
4. The earth leakage currents are higher than 3.5 mA.
5. Protection against motor overload is not included in the factory setting. If this function is desired, set par. F-10 *Electronic Overload* to data value *Electronic Overload trip* or data value *Electronic Overload warning*. Note: The function is initialised at 1.16 x rated motor current and rated motor frequency. For the North American market: The Electronic Overload functions provide class 20 motor overload protection in accordance with NEC.
6. Do not remove the plugs for the motor and mains supply while the frequency converter is connected to mains. Check that the mains supply has been disconnected and that the necessary time has passed before removing motor and mains plugs.
7. Please note that the frequency converter has more voltage inputs than L1, L2 and L3, when load sharing (linking of DC intermediate circuit) and external 24 V DC have been installed. Check that all voltage inputs have been disconnected and that the necessary time has passed before commencing repair work.

1.2.3 Warning Against Unintended Start

1. The motor can be brought to a stop by means of digital commands, network commands, references or a local stop, while the frequency converter is connected to mains. If personal safety considerations make it necessary to ensure that no unintended start occurs, these stop functions are not sufficient.
2. While parameters are being changed, the motor may start. Consequently, the Off key on the keypad must always be activated; following which data can be modified.
3. A motor that has been stopped may start if faults occur in the electronics of the frequency converter, or if a temporary overload or a fault in the supply mains or the motor connection ceases.

1.2.4 Warning



Touching the electrical parts may be fatal - even after the equipment has been disconnected from mains.

Also make sure that other voltage inputs have been disconnected, such as an external 24V DC using option module OPC24VPS, load sharing (linkage of DC intermediate circuit), as well as the motor connection for kinetic back up.

Please refer to the AF-650 GP or AF-600 FP Drive Operating Instructions for further safety guidelines.



1.3 About this Manual

First time users can obtain the most essential information for quick installation and set-up in these chapters:

- Introduction
- How to Install
- How to Configure the System
- Application Examples

For more detailed information including the full range of set-up options and diagnostics tools please refer to the chapters:

- How to Control the Frequency Converter
- How to Access the Parameters
- Parameters
- Troubleshooting

1.4 Technical Overview

DeviceNet is a low-level network that standardizes communications between industrial devices (sensors, limit switches, motor controls) and high-level devices (controllers). DeviceNet follows the Open Systems Interconnection (OSI) model and is based on CAN technology for Media Access Control and Physical Signalling.

DeviceNet systems can be configured to operate in a master-slave or a distributed control architecture using peer-to-peer communication. Up to 63 nodes in a multi-drop network topology are supported, and communication options can be powered directly from the bus, using the same cable for communication. Nodes can be removed or inserted without powering down the network.

Each node on the network has its own unique Media Access Control Identifier (MAC ID) to distinguish it on the network. The access control is based on the CSMA/CA (Carrier Sense Multiple Access / Collision Avoidance) principle, meaning that all nodes may have access to the network at the same time. If two nodes attempt to get control of the network bus simultaneously, the CAN protocol resolves the issue by arbitration. In this way collisions on the network are avoided.

DeviceNet defines device profiles for devices belonging to specific classes. For other devices, a custom class must be defined in order to make it DeviceNet compatible. This further enhances the interchangeability and interoperability of the network.

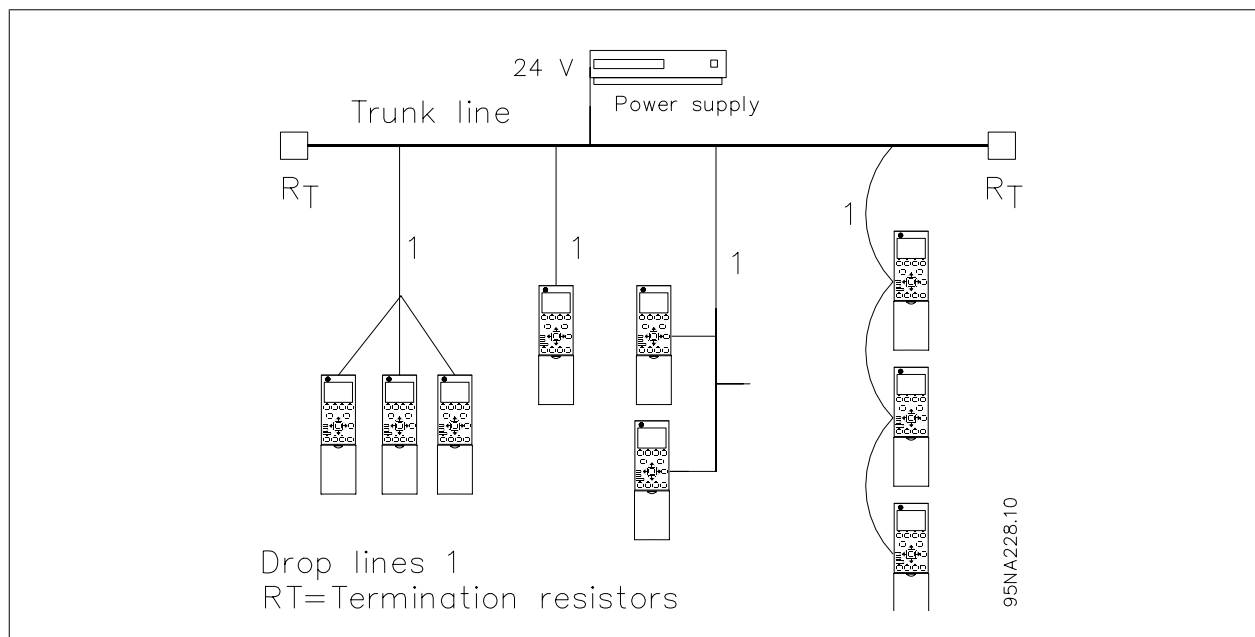

Illustration 1.1: Topology



1

1.5 Assumptions

These operating instructions assume that you are using an AF-650 GP or AF-600 FP frequency converter with a DeviceNet option module installed in the drive.. It is also assumed that you are using a PLC or PC based scanner equipped with a serial communication card supporting all the DeviceNet communication services required by your application. Furthermore, it is assumed that all requirements stipulated in the DeviceNet standard as well as those set up in the AC Drive Profile and those pertaining to the frequency converter are strictly observed as well as all limitations therein fully respected.

1.6 Hardware

These operating instructions relate to the DeviceNet option Model No. OPCDEV.

1.7 Background Knowledge

The GE DeviceNet is designed to communicate with any master abiding by the DeviceNet standard. It is therefore assumed that you have full knowledge of the PC or PLC you intend to use as a master in your system. Any questions pertaining to hardware or software produced by any other manufacturer is beyond the scope of these operating instructions. If you have questions about how to set up master - master communication or communication to a non-GE slave, please consult the appropriate documentation.

1.8 Available Literature

For additional AF-6 Series Drives information please visit www.geelectrical.com/drives.

1.9 Abbreviations

ACK	ACKnowledge
BOC	Bus Off Counter
BOOL	BOOLean expression
CAN	Controller Area Network
CSMA/CA	Carrier Sense Multiple Access/Collision Avoidance
COS	Change of State
CTW	Control Word
EDS	Electronic Data Sheet
EMC	Electromagnetic Compatibility
ETR	Electronic Thermal Relay
FIFO	First In First Out
HF	High Frequency
HPFB	High Performance Field Bus
I/O	Input/Output
ISO	International Standards Organization
LCD	Liquid Crystal Display
LED	Light Emitting Diode
LSB	Least Significant Bit
MAC ID	Media Access Control IDentifier
MAV	Main Actual Value
MRV	Main Reference Value
MSB	Most Significant Bit
N/A	Not Applicable
ODVA	Open DeviceNet Vendor Association
OSI	Open Systems Interconnection
PC	Personal Computer
PCD	Process Data
PIW	Peripheral Input Word
PLC	Programmable Logic Control
PNU	Parameter Number
PPO	Parameter-Process Data Object
QW	Peripheral Output Word
SINT	Signed Integer
STW	Status Word
VSD	Variable Speed Drive
UDINT	Unsigned Double Integer
UNIT	Unsigned Integer
USINT	Unsigned Short Integer



2 How to Install

2.1 Cabling

2.1.1 Cable Lengths

Baud rate	Max total cable length	Drop length	
		Maximum per drop	Cumulative maximum
125k baud	500 meters (1640 ft.)	6 meters (20 ft.) for one drop	156 meters (512 ft.)
250k baud	250 meters (820 ft.)		78 meters (256 ft.)
500k baud	100 meters (328 ft.)		39 meters (128 ft.)

2.1.2 Cable Specifications

The cable used should be according to ODVA specifications.

Be aware that the ODVA "Flat Cable" is an unshielded cable type, and is not suited for use with frequency converters.

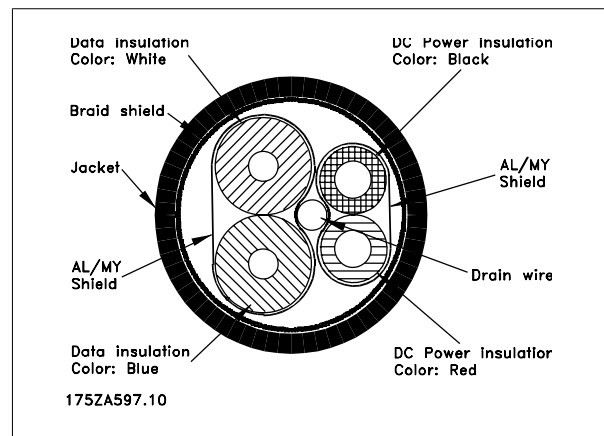

Illustration 2.1: ODVA "Thin Cable" cross section

2.1.3 EMC Precautions

The following EMC precautions are recommended in order to achieve interference-free operation of the DeviceNet network. Additional EMC information is available in the relevant AF-600 FPAF-650 GP or AF-600 FP Operating Instructions.

2

NB!

Relevant national and local regulations, for example regarding protective earth connection, must be observed.

The DeviceNet communication cable must be kept away from motor and brake resistor cables to avoid coupling of high frequency noise from one cable to the other. Normally a distance of 200 mm (8 inches) is sufficient, but it is generally recommended to keep the greatest possible distance between the cables, especially where cables run in parallel over long distances. If the DeviceNet cable has to cross a motor and brake resistor cable they must cross each other at an angle of 90 degrees.

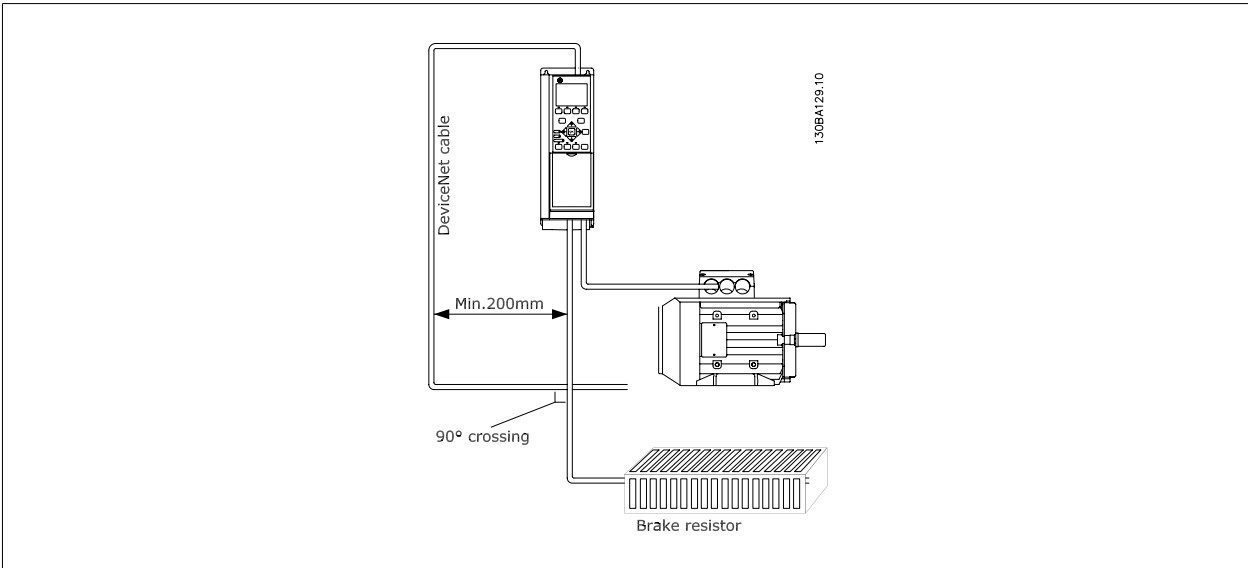

2.1.4 Connection of the Cable Screen

GE recommends connection of the screen of the DeviceNet cable to ground at both ends of the cable at every DeviceNet station (see GE recommendation for further details). Low impedance ground connection of the screen is very important, also at high frequencies. Achieve this by connecting the surface of the screen to ground, for example by means of a cable clamp or a conductive cable gland. The frequency converter package includes various clamps and brackets to enable a proper ground connection of the DeviceNet cable screen. The screen connection required for CE and EMC compliance is shown in the following drawing.

2.1.5 ODVA Recommendation

The Screen must be connected to ground at only one point on the network.

NB!

Please note that this recommendation conflicts with the correct EMC installation.

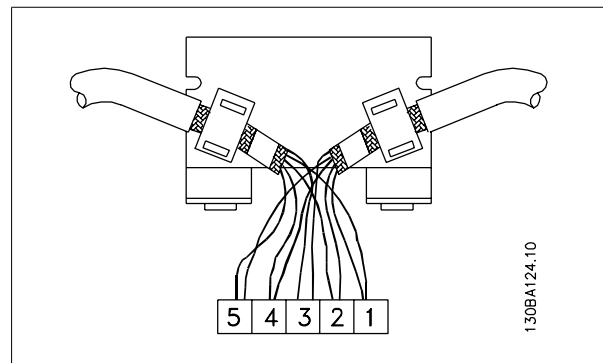



2.1.6 Earth Connection

It is important that all stations connected to the DeviceNet network are connected to the same earth potential. The earth connection must have a low HF (high frequency) impedance. This can be achieved by connecting a large surface area of the cabinet to ground, for example by mounting the frequency converter on a conductive rear plate.

NB!
Particularly when there are long distances between the stations in a DeviceNet network, it may be necessary to use additional potential equalizing cables, connecting the individual stations to the same earth potential.

Pin no.	Terminal	Colour	Name
1	V-	Black	GND
2	CAN_L	Blue	CAN LOW
3	Drain	(bare)	Screen
4	CAN_H	White	CAN HIGH
5	V+	Red	+24 V

2.1.7 DeviceNet Connection

It is essential to terminate the bus line properly. A mismatch of impedance may result in reflections on the line that will corrupt data transmission. The DeviceNet option module is provided with a plug-cable connector. When a plug connector is used as a splice between two trunk lines, the removal of devices will not sever the network.

NB!
Install wires only when the network is inactive. This will prevent problems such as shorting the network supply or disrupting communications.

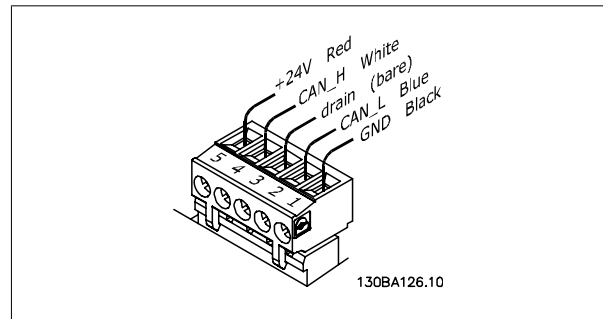

2.1.8 DeviceNet Termination

Termination resistors should be installed at each end of the bus line. The resistors must be mounted between terminal 2 (CAN_L) and terminal 4 (CAN_H) and should have the following specification:
121 Ohm, 1 % Metal film, 1/4 Watt

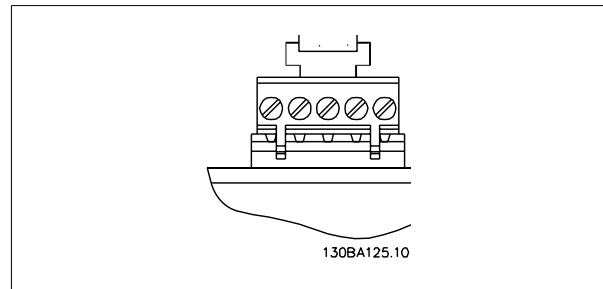

2.1.9 Drop Cable

An alternative to splicing two trunk lines in the connector on the control card is to use a DeviceNet connection box or a T-connector.

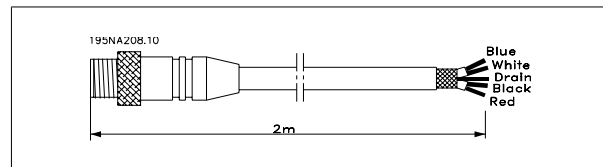



2.1.10 Network Power Consumption

The DeviceNet option module is powered via the internal power supply in the drive. The network voltage (+24 V) is detected only to determine if the bus is energized or not, thus the current draw from the network is negligible.

2

2.2 Installation of the DeviceNet option module

To install the DeviceNet option module in the frequency converter you will need:

- The DeviceNet option module (OPCDEV)
- Network option adaptor frame for the frequency converters below 230V, 7.5HP and 460V/575V, 15HP drives. This frame is deeper than the standard frame, to allow space for the fieldbus option beneath.

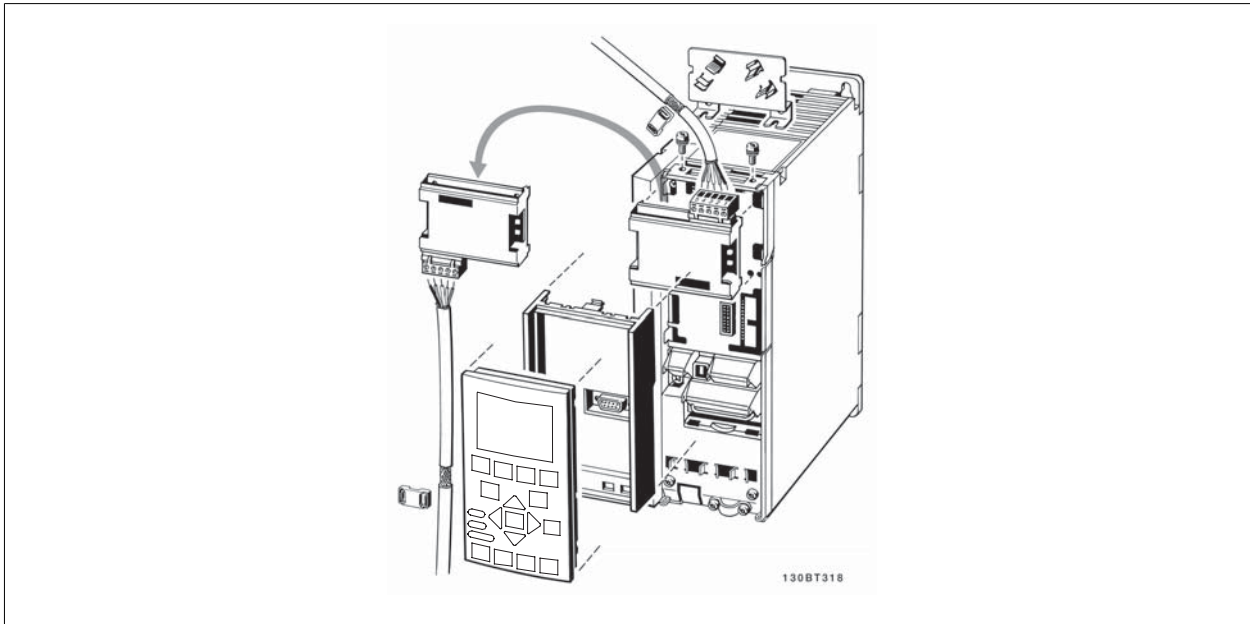

Instructions:

- Remove the keypad from the frequency converter.
- Remove the frame located beneath and discard.
- Push the DeviceNet option module into place. Two positions are possible, with cable terminal facing either up or down. The cable up position is often most suitable when several frequency converters are installed side by side in a rack, as this position permits shorter cable lengths.
- Push the DeviceNet option module adaptor frame for the frequency converter into place.
- Replace the Keypad.
- Attach cable.
- If an option is installed after initial power-up the frequency converter will be tripped and display: Alarm 67 *Option Change*.



3 How to Configure the System

3.1 Configure the DeviceNet Network

All DeviceNet stations that are connected to the same network must have a unique station address. The DeviceNet address of the frequency converter can be selected via:

- Hardware switches (default 63)
- par. DN-02 MAC ID (default 63)
- Class code 0X03, Instance 1, Attribute 1

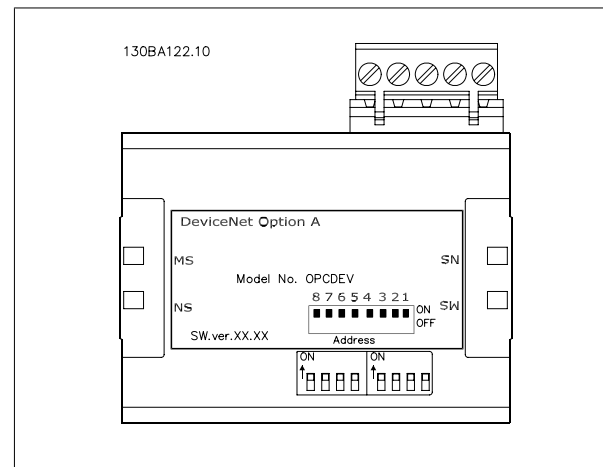

3

3.1.1 Setting the DeviceNet Address using the Hardware Switches

Setting the DeviceNet Address using the Hardware Switches: Using the hardware switches it is possible to select an address range from 0-63 (factory setting 63) according to the table below:

Switch	8	7	6	5	4	3	2	1
Address value	-	-	+32	+16	+8	+4	+2	+1
Ex. address 5	-	-	OFF	OFF	OFF	ON	OFF	ON
Ex. address 20	-	-	OFF	ON	OFF	ON	OFF	OFF
Ex. address 35	-	-	ON	OFF	OFF	OFF	ON	ON

NB!

Switch off the power supply before changing the hardware switches.

The address change will come into effect at the next power-up, and can be read in par. DN-02 MAC ID.

3.1.2 Setting the DeviceNet Address via par. DN-02 MAC ID

The address can be set via par. DN-02 MAC ID if the hardware switches are set to 63 (factory setting). The address change will come into effect at the next power-up.

3.1.3 Setting the DeviceNet Address with the Object Class Code 0x03, Attribute 1, Instance 1

The address can be set via the DeviceNet object class code 0x03 attribute 1 command if the hardware switch is set to 63 (factory setting). A new address becomes effective immediately after the class code 0x03, Instance 1, Attribute 1 command.



3.1.4 Baud Rate Setting

All DeviceNet stations connected to the same bus network must have the same Baud rate. The baud rate of the frequency converter can be selected via:

- Hardware switches
- par. DN-01 *Baud Rate Select* (default 125k Baud)
- Object Class code 0x03, Instance 1, Attribute 2.

3

3.1.5 Setting the DeviceNet Baud Rate using the Hardware Switches

Using the hardware switches it is possible to select a baud rate of 125k baud (factory setting), 250k baud or 500 k baud according to the following table:

Baud rate switch	8	7
par. DN-01 <i>Baud Rate Select</i>	1	1
125 k Baud	0	0
250 k Baud	0	1
500 k Baud	1	0

NB!

Switch off the power supply before changing the hardware switches.

The baud rate change will come into effect at the next power-up, and can be read in par. DN-01 *Baud Rate Select*.

3.1.6 Setting the DeviceNet Baud Rate via par. DN-01 *Baud Rate Select*

The baud rate can be set via par. DN-01 *Baud Rate Select* if the hardware switches 1 and 2 are set to ON (factory setting). The baud rate change will come into effect at the next power-up.

3.1.7 Setting the DeviceNet Baud Rate with the Object Class Code 0x03 Attribute 2

The baud rate can be set via the DeviceNet object class code 0x03 attribute 2 command, if the hardware switches 1 and 2 are set to ON (factory setting). A new baud rate becomes effective immediately after the class code 0x03 attribute 2 command.



3.2 Configure the Master

3.2.1 EDS File

A large part of the system configuration is the setting of application related parameters. EDS (Electronic Data Sheet) files simplify the setting up of most of the DeviceNet configurable parameters. GE provides a generic English EDS file covering all voltage and power sizes, for off-line configuration. The EDS file can be downloaded from <http://www.geelectrical.com/drives>.

NB!

The EDS-file does not contain all parameters but a selected, limited number of parameters with generic minimum, maximum and default values.

3.3 Configure the Frequency Converter

3.3.1 Frequency Converter Parameters

Pay particular attention to the following parameters when configuring the frequency converter with a DeviceNet interface. Please refer to the Parameters chapter for more details of each parameter.

- par. K-40 *[Hand] Button on Keypad*.
If the Hand button on the frequency converter is activated, control of the drive via the DeviceNet interface is disabled. After initial power-up the frequency converter will automatically detect whether a fieldbus option is installed in slot A, and set par. O-02 *Control Word Source* to [Option A]. If an option is added to, changed in or removed from an already commissioned drive, it will not change par. O-02 *Control Word Source* but will enter Trip Mode, and the frequency converter will display an error.
- par. O-10 *Control Word Profile* (see section *How to Control the Frequency Converter*). Choose between the GE Drive Profile and the ODVA profile. Select the desired DeviceNet instance in par. DN-10 *Process Data Type Selection*.
- par. O-50 *Coasting Select* to par. O-56 *Preset Reference Select* (see section *Parameters*). Selection of how to gate the DeviceNet control commands with digital input command of the control card.

NB!

When par. O-01 *Control Site* is set to [2] Control word only, then the settings in par. O-50 *Coasting Select* to par. O-56 *Preset Reference Select* will be overruled, and will all act on Bus-control

- par. O-03 *Control Word Timeout Time* to par. O-05 *End-of-Timeout Function*. The reaction in the event of a bus time out is set via these parameters
- par. DN-10 *Process Data Type Selection*. Default is 125 kbps.
- par. DN-02 *MAC ID*. Default is 63.

3.3.2 LEDs

The DeviceNet control card contains two bi-colour (green/red) LEDs for each connector hook-up port, to indicate the state of the device and the network respectively. For details of the range of communications status indicated by the LEDs, please refer to the Troubleshooting chapter.





4 How to Control the Frequency Converter

4.1 DeviceNet Process Control Modes

This section describes two of three possible process control modes: Polling and Change of State (COS). The third drive control mode uses the acyclical mode Explicit Messaging via the Standard DeviceNet Control Supervisory object CLASS 29H. The Control Supervisory object is described within the *DeviceNet Object Classes* section, *How to Access the Parameters* chapter.

4.1.1 Polling

This is a classical Master-Slave connection and the standard DeviceNet operation mode. The master controls the data exchange by sending cyclical poll-requests to the connected slaves, and the slaves answers by sending a poll-response to the master. The master can control and monitor the frequency converter by polling the DeviceNet or GE drive objects (I/O Instances).

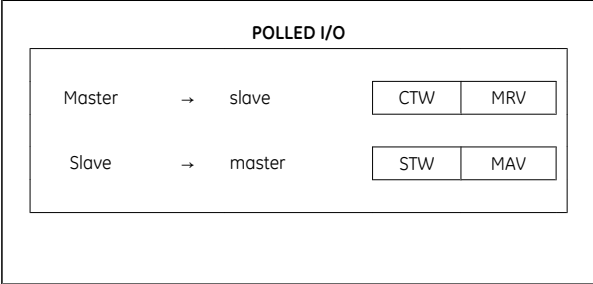

4.1.2 Change of State, COS

This an event-controlled operation mode used to minimize network traffic. Messages are transmitted only if a defined state or value has changed. The condition for triggering a COS message is determined by the insertion of COS-filters (par. DN-20 *COS Filter 1* to par. DN-23 *COS Filter 4*), for each bit in the different PCD-words. The filter acts like a logical AND-function: If a bit in the filter is set to "1", the COS-function triggers upon a change to the corresponding bit for the PCD-word.

The figure below shows the different PCDs and their corresponding filter parameters.

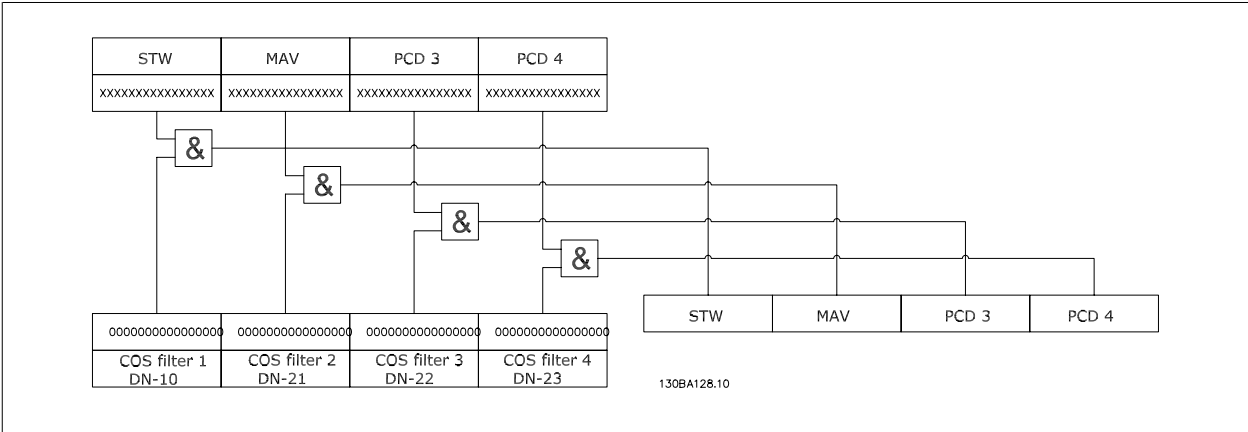

par. DN-20 *COS Filter 1* to par. DN-23 *COS Filter 4* can be used to filter out undesired events for COS. If a filter bit is set to 0, the corresponding I/O Instance bit will be unable to produce a COS message. By default, all bits in the COS filters are set to 0.

In order to signal that the connection has not been interrupted, or the device is not powered off, a Heartbeat Message is transmitted within a specified time interval (Heartbeat Interval). This interval is defined in Attribute Heartbeat Time of the connection object, Class Code 0x05.

To prevent the device from producing heavy network traffic if a value changes frequently, the Production Inhibit Time (an attribute of the connection object) is defined. This parameter defines the minimum time between two COS messages.



The Attribute Expected Package Rate defines the maximum time between two COS messages even when the value is unchanged. In the event of COS connection, the Explicit Package Rate is identical with the Heartbeat Interval mentioned above. This timer is used both as transmission trigger and inactivity watchdog, depending upon whether the connection is producer or consumer.

4.2 I/O Assembly Instances

I/O Assembly Instances are a number of defined process control objects with defined content comprising control and status information. The figure below shows the I/O Assembly Instance options for controlling and monitoring the frequency converter.

4

PCD no.	Output (write)								Input (read)								Drive Profile		
	1		2		3		4		1		2		3		4				
Byte no.	0	1	2	3	4	5	6	7	0	1	2	3	4	5	6	7			
20/70	CTW		Speed ref.						STW		Actual RPM						ODVA		
21/71	CTW		Speed ref.						STW		Actual RPM						ODVA		
100/150	CTW		MRV						STW		MAV						GE		
101/151	CTW		MRV		User defined		PCD 3		PCD 4		STW		MAV		User defined		PCD 3	PCD 4	GE

130BA133.10

4.3 Process Data

Process data comprises the control and status data in the I/O Assembly Instances.

The CTW, MRV and STW and MAV have defined formats and functions, depending upon the I/O Instance chosen. PCD3 and PCD4 are freely configurable for instance 101/151 via par. DN-11 *Process Data Config Write* and par. DN-12 *Process Data Config Read*.

All PCDs are freely configurable for instance 102/152

DeviceNet provides a flexible way for the user to customize the number of Process Data (I/O words) and the functionality of each word. To activate the user definable process data, select the I/O Instance 101/151 in par. DN-10 *Process Data Type Selection*. This will change the I/O size to four words in the input and output area. This selection uses the GE-specific profile for the Control word and Status word as well for the Main Reference Value/Main Actual Value.

The first two words are fixed on the DeviceNet, whereas the user can select the input and output, PCD 3 and PCD 4. The number of PCDs active in a system is fixed to 2 words.

NB!
Selection of Instance 101/151 under par. DN-10 *Process Data Type Selection* is only possible if GE Drive Profile has been selected in par. O-10 *Control Word Profile*.

To enable use of PCD data from the DeviceNet, configure the contents of each single PCD word in par. DN-11 *Process Data Config Write* and par. DN-12 *Process Data Config Read*. Changes to par. DN-11 *Process Data Config Write* and par. DN-12 *Process Data Config Read* are effected immediately in the PCD data.

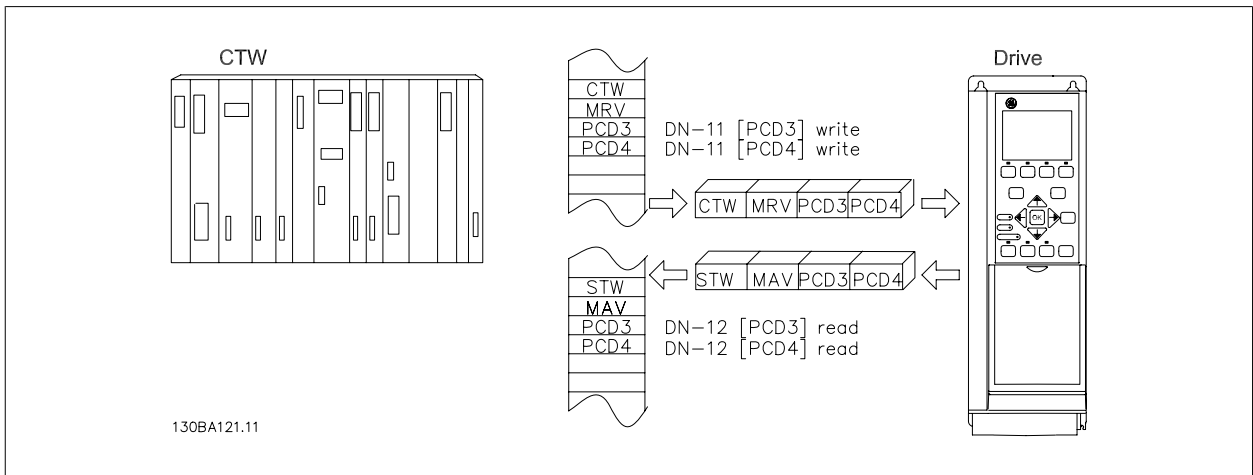

4.4 ODVA Control Profile

4.4.1 Control Word under Instances 20/70 and 21/71

Control Word under Instances 20/70 and 21/71 Set par. 0-10 Control Word Profile to ODVA, and select the instance in par. DN-10 Process Data Type Selection.

The control word in Instances 20 and 21 is defined in the overview to the right:

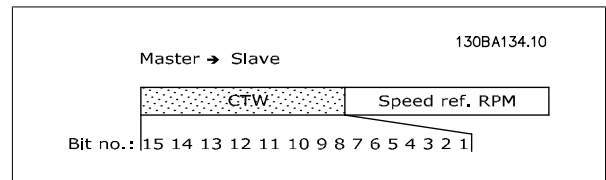

NB!
Note that the bits 00 and 02 in Instance 20 are identical with bits 00 and 02 in the more extensive Instance 21.

Bit	Instance 20		Instance 21	
	Bit = 0	Bit = 1	Bit = 0	Bit = 1
00	Stop	Run Fwd	Stop	Run Fwd
01	-	-	Stop	Run Rev
02	No function	Fault reset	No function	Fault reset
03	-	-	-	-
04	-	-	-	-
05	-	-	-	Net Ctrl
06	-	-	-	Net Ref
07-15	-	-	-	-

Explanation of the Bits:

Bit 0, Run Fwd:

Bit 0 = "0" means that the frequency converter has a stop command.

Bit 0 = "1" leads to a start command and the frequency converter will start to run the motor clockwise.

Bit 1, Run Rev:

Bit 1 = "0" leads to a stop of the motor.

Bit 1 = "1" leads to a start of the motor.

Bit 2, Fault Reset:

Bit 2 = "0" means that there is no reset of a trip.

Bit 2 = "1" means that a trip is reset.

Bit 3, No function:

Bit 3 has no function.

Bit 4, No function:

Bit 4 has no function.



Bit 5, Net Control:

Bit 5 = "0" means that the drive is controlled from the standard inputs.
 Bit 5 = "1" means that DeviceNet controls the drive.

NB!
 Please note that changes will affect par. O-50 *Coasting Select* to par. O-56 *Preset Reference Select*.

Bit 6, Net Reference:

Bit 6 = "0" Reference is from the standard inputs.
 Bit 6 = "1" Reference is from DeviceNet.

4

NB!
 Please note that changes will affect par. F-01 *Frequency Setting 1* to par. C-34 *Frequency Command 3*.

For the Speed reference, see section *Bus Speed Reference Value under Instances 20/70 and 21/71*.

4.4.2 Status Word under Instances 20/70 and 21/71

The status word in Instances 70 and 71 is defined in the overview to the right:

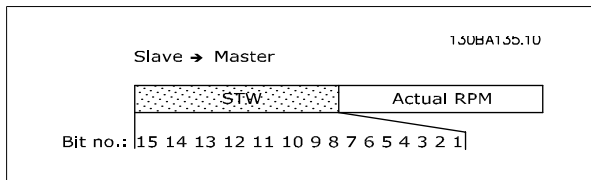

NB!
 Note that the bits 00 and 02 in Instance 70 are identical with bits 00 and 02 in the more extensive Instance 71.

Bit	Instance 70		Instance 71	
	Bit = 0	Bit = 1	Bit = 0	Bit = 1
00	-	Fault	-	Fault
01	-	-	-	Warning
02	-	Running 1 Fwd	-	Running 1 Fwd
03	-	-	-	Running 2 Rev.
04	-	-	-	Ready
05	-	-	-	Ctrl from Net
06	-	-	-	Ref. from Net
07	-	-	-	At ref.
08-15	-	-	State Attribute	

Explanation of the Bits:

Bit 0, Fault:

Bit 0 = "0" means that there is no fault in the frequency converter.
 Bit 0 = "1" means that there is a fault in the frequency converter.

Bit 1, Warning:

Bit 0 = "0" means that there is no unusual situation.
 Bit 0 = "1" means that an abnormal condition has arisen.

Bit 2, Running 1:

Bit 2 = "0" means that the drive is not in one of these states or that Run 1 is not set.
 Bit 2 = "1" means that the drive state attribute is enabled or stopping, or that Fault-Stop and bit 0 (Run 1) of the control word are set at the same time.

Bit 3, Running 2:

Bit 3 = "0" means that the drive is in neither of these states or that Run 2 is not set.
 Bit 3 = "1" means that the drive state attribute is enabled or stopping, or that fault-stop and bit 0 (Run 2) of the control word are set at the same time.

Bit 4, Ready:

Bit 4 = "0" means that the state attribute is in another state.

Bit 4 = "1" means that the state attribute is ready, enabled or stopping.

Bit 5, Control from net:

Bit 5 = "0" means that the drive is controlled from the standard inputs.

Bit 5 = "1" means that DeviceNet has control (start, stop, reverse) of the drive.

Bit 6, Ref from net:

Bit 6 = "0" means that the reference comes from inputs to the drive.

Bit 6 = "1" means that the reference comes from DeviceNet.

Bit 7, At reference:

Bit 7 = "0" means that the motor is running, but that the present speed is different from the preset speed reference, i.e. the speed is accelerating/decelerating during start/stop.

Bit 7 = "1" means that the drive and reference speeds are equal.

Bit 8 - 15, State attribute:

(Instance 71 only)

Represents the state attribute of the drive, as indicated in the table to the right:

Bit Number	Meaning
8	(Vendor specific)
9	Start up
10	Not ready
11	Ready
12	Enabled
13	Stopping
14	Fault stop
15	Faulted

For more detail of the actual output speed, see the section *Actual Output Speed under Instances 20/70 and 21/71*.

4.4.3 Bus Speed Reference Value under Instances 20/70 and 21/71

The speed reference value is transmitted to the frequency converter in the form of a 16-bit word. The value is transmitted as a whole number. Negative figures are formatted by means of 2's complement.

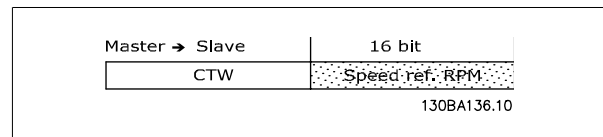

The bus speed reference has the following format:

par. F-50 Reference Range = "0" [ref_{MIN} → ref_{MAX}] 0 (0000 Hex) [RPM] ⇒ +32767 (7FFF Hex) [RPM]

par. F-50 Reference Range = "1" [-ref_{MAX} → +ref_{MAX}] -32767 (8001 Hex) ⇒ +32767 [RPM] (7FFF Hex)

The actual reference [Ref. %] in the frequency converter depends on the settings in the following parameters:

par. F-04 Base Frequency

par. P-06 Base Speed

par. F-53 Maximum Reference

Note that if the bus speed reference is negative, and the control word contains a run reverse signal, the drive will run clockwise.



Example:

- par. P-06 Base Speed = 1420 RPM
- par. F-04 Base Frequency = 50 Hz
- par. F-53 Maximum Reference = 1420 RPM

In order to run the motor at 25%, the reference transmitted must be: $(1420 \times 0,25) = 355 = 163\text{hex}$

163hex => 25% => Fout = 12,5Hz

4

4.4.4 Actual Output Speed under Instances 20/70 and 21/71

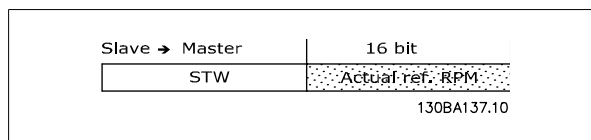

The value of the actual speed of the motor is transmitted in the form of a 16-bit word. The value is transmitted as a whole number. Negative figures are formed by means of 2s complement.

The actual speed value has the following format:

-32767 (8000 Hex) [RPM] -> +32767 [RPM] (7FFF Hex) [RPM]

4.5 GE Drive Control Profile

4.5.1 Control Word under Instances 100/150, 101/151 and 102/152

To select GE drive protocol in the control word, par. O-10 Control Word Profile must be set to Drive protocol [0]. The control word is used to send commands from a master (PLC or PC) to a slave (frequency converter).

The control words in Instances 100/101/102 are defined as follows to the right:

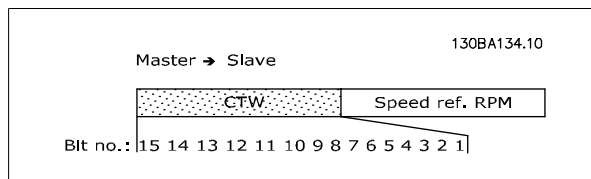

Bit	Bit value = 0	Bit value = 1
00	Reference value	External selection lsb
01	Reference value	External selection msb
02	DC brake	Ramp
03	Coasting	No coasting
04	Quick stop	Ramp
05	Hold output frequency	Use ramp
06	Ramp stop	Start
07	No function	Reset
08	No function	Jog
09	Ramp 1	Ramp 2
10	Data invalid	Data valid
11	No function	Relay 01 active
12	No function	Relay 04 active
13	Parameter set-up	Selection lsb
14	Parameter set-up	Selection msb
15	No function	Reverse

Explanation of the Control Bits:

Bits 00/01

Bits 00 and 01 are used to choose between the four reference values, which are pre-programmed in par. C-05 Multi-step Frequency 1 - 8 according to the table to the right:



Programmed ref. value	Parameter	Bit 01	Bit 00
1	C-05 [0]	0	0
2	C-05 [1]	0	1
3	C-05 [2]	1	0
4	C-05 [3]	1	1

NB!

In par. O-56 *Preset Reference Select* a selection is made to define how Bit 00/01 gates with the corresponding function on the digital inputs.

Bit 02, DC brake:

Bit 02 = 0 leads to DC braking and stop. Braking current and duration are set in par. B-01 *DC Brake Current* and par. B-02 *DC Braking Time*.

Bit 02 = 1 leads to ramping.

Bit 03, Coasting:

Bit 03 = 0 causes the frequency converter to immediately "let go" of the motor (the output transistors are "shut off"), so that it coasts to a standstill.

Bit 03 = 1 enables the frequency converter to start the motor if the other starting conditions have been fulfilled.

NB!

In par. O-50 *Coasting Select* a selection is made to define how Bit 03 gates with the corresponding function on a digital input.

Bit 04, Quick stop:

Bit 04 = 0 causes a stop, in which the motor speed is decelerated to stop via par. C-23 *Quick Stop Decel Time*.

Bit 05, Hold output frequency:

Bit 05 = 0 causes the present output frequency (in Hz) to freeze. The frozen output frequency can then be changed only by means of the digital inputs (par. E-01 *Terminal 18 Digital Input* to par. E-06 *Terminal 33 Digital Input*) programmed to Speed up and Speed down.

NB!

If Hold output is active, only the following can stop the frequency converter:

- Bit 03 Coasting stop
- Bit 02 DC braking
- Digital input (par. E-01 *Terminal 18 Digital Input* to par. E-06 *Terminal 33 Digital Input*) programmed to DC braking, Coasting stop or Reset and coasting stop.

Bit 06, Ramp stop/start:

Bit 06 = 0 causes a stop, in which the motor speed is decelerated to stop via the selected *ramp down* parameter.

Bit 06 = 1 permits the frequency converter to start the motor, if the other starting conditions have been fulfilled.

NB!

In par. O-53 *Start Select* a selection is made to define how Bit 06 Ramp stop/start gates with the corresponding function on a digital input.

Bit 07, Reset:

Bit 07 = 0 does not cause a reset.

Bit 07 = 1 causes the reset of a trip. Reset is activated on the leading edge of the signal, i.e. when changing from logic 0 to logic 1.

Bit 08, Jog:

Bit 08 = 1 causes the output frequency to be determined by par. C-21 *Jog Speed [RPM]*.

Bit 09, Selection of ramp 1/2:

Bit 09 = "0" means that ramp 1 is active (par. H-07 *Accel/Decel Time 1 Type* to par. SP-73 *Decel Time 1 S-ramp Ratio at Decel. Start*).



Bit 09 = "1" means that ramp 2 (par. SP-76 *Accel/Decel Time 2 Type* to par. SP-81 *Decel Time 2 S-ramp Ratio at Decel. Start*) is active.

Bit 10, Data not valid/Data valid:

Is used to tell the frequency converter whether the control word is to be used or ignored. Bit 10 = 0 causes the control word to be ignored, Bit 10 = 1 causes the control word to be used. This function is relevant, because the control word is always contained in the telegram, regardless of which type of telegram is used, i.e. it is possible to turn off the control word if you do not wish to use it in connection with updating or reading parameters.

Set-up	Bit 14	Bit 13
1	0	0
2	0	1
3	1	0
4	1	1

4

Bit 11, Relay 01:

Bit 11 = "0" Relay not activated.

Bit 11 = "1" Relay 01 activated, provided Control word bit 11 has been chosen in par. E-24 *Function Relay*.

Bit 12, Relay 04:

Bit 12 = "0" Relay 04 has not been activated.

Bit 12 = "1" Relay 04 has been activated, provided Control word bit 12 has been chosen in par. E-24 *Function Relay*.

Bit 13/14, Selection of set-up:

Bits 13 and 14 are used to choose from the four menu set-ups according to the table to the right:

The function is only possible when Multi-Set-ups is selected in par. K-10 *Active Set-up*.

NB!
In par. O-55 *Set-up Select* a selection is made to define how Bits 13/14 gate with the corresponding function on the digital inputs.

Bit 15 Reverse:

Bit 15 = 0 causes no reversing.

Bit 15 = 1 causes reversing.



4.5.2 Status Word under Instances 100/150, 101/151 and 102/152

The status words in Instances 150/151/152 are defined as follows to the right:

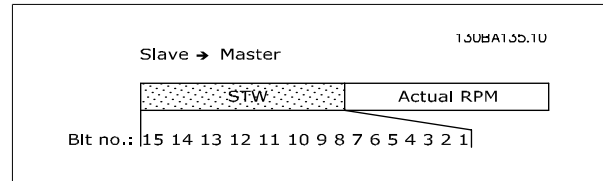

Bit	Bit = 0	Bit = 1
00	Control not ready	Control ready
01	Drive not ready	Drive ready
02	Coasting	Enable
03	No error	Trip
04	No error	Error (no trip)
05	Reserved	-
06	No error	Trip lock
07	No warning	Warning
08	Speed reference	Speed = reference
09	Local operation	Bus control
10	Out of frequency limit	Frequency limit ok
11	No operation	In operation
12	Drive ok	Stopped, auto start
13	Voltage ok	Voltage exceeded
14	Torque ok	Torque exceeded
15	Timer ok	Timer exceeded



Explanation of the Status Bits:

Bit 00, Control not ready/ready:

Bit 00 = 0 means that the frequency converter has tripped.

Bit 00 = 1 means that the frequency converter controls are ready, but that the power component is not necessarily receiving any power supply (in case of external 24 V supply to controls).

Bit 01, Drive ready:

Bit 01 = 1. The frequency converter is ready for operation.

Bit 02, Coasting stop:

Bit 02 = 0. The frequency converter has released the motor.

Bit 02 = 1. The frequency converter can start the motor when a start command is given.

Bit 03, No error/trip:

Bit 03 = 0 means that the frequency converter is not in fault mode.

Bit 03 = 1 means that the frequency converter is tripped, and that a reset signal is required to re-establish operation.

Bit 04, No error/error (no trip):

Bit 04 = 0 means that the frequency converter is not in fault mode.

Bit 04 = 1 means that there is a frequency converter error but no trip.

Bit 05, Not used:

Bit 05 is not used in the status word.

Bit 06, No error / trip lock:

Bit 06 = 0 means that the frequency converter is not in fault mode.

Bit 06 = 1 means that the frequency converter is tripped, and locked.

Bit 07, No warning/warning:

Bit 07 = 0 means that there are no warnings.

Bit 07 = 1 means that a warning has occurred.

Bit 08, Speed reference/speed = reference:

Bit 08 = 0 means that the motor is running, but that the present speed is different from the preset speed reference. It might, for example, be the case while the speed is being accelerated/decelerated during start/stop.

Bit 08 = 1 means that the present motor present speed matches the preset speed reference.

Bit 09, Local operation/bus control:

Bit 09 = 0 means that [STOP/RESET] is activated on the control unit, or that Local control in par. F-02 *Operation Method* is selected. It is not possible to control the frequency converter via serial communication.

Bit 09 = 1 means that it is possible to control the frequency converter via the fieldbus/ serial communication.

Bit 10, Out of frequency limit:

Bit 10 = 0, if the output frequency has reached the value in par. H-72 *Warning Speed Low* or par. H-73 *Warning Speed High*.

Bit 10 = "1" means that the output frequency is within the defined limits.

Bit 11, No operation/in operation:

Bit 11 = 0 means that the motor is not running.

Bit 11 = 1 means that the frequency converter has a start signal or that the output frequency is greater than 0 Hz.

Bit 12, Drive OK/stopped, auto start:

Bit 12 = 0 means that there is no temporary over temperature on the drive.

Bit 12 = 1 means that the drive has stopped because of over temperature, but that the unit has not tripped and will resume operation once the over temperature stops.

Bit 13, Voltage OK/limit exceeded:

Bit 13 = 0 means that there are no voltage warnings.

Bit 13 = 1 means that the DC voltage in the frequency converters intermediate circuit is too low or too high.

Bit 14, Torque OK/limit exceeded:

Bit 14 = 0 means that the motor current is lower than the torque limit selected in par. F-40 *Torque Limiter (Driving)* or par. F-41 *Torque Limiter (Braking)*.

Bit 14 = 1 means that the torque limits in par. F-40 *Torque Limiter (Driving)* and par. F-41 *Torque Limiter (Braking)* have been exceeded.

Bit 15, Timer OK/limit exceeded:

Bit 15 = 0 means that the timers for motor thermal protection and drive thermal protection, respectively, have not exceeded 100%.

Bit 15 = 1 means that one of the timers has exceeded 100%.



4.5.3 Bus Reference Value under Instances 100/150 and 101/151

The frequency reference value is transmitted to the frequency converter in the form of a 16-bit word. The value is transmitted as a whole number (-32767 to 32767). Negative figures are formatted by means of 2's complement.

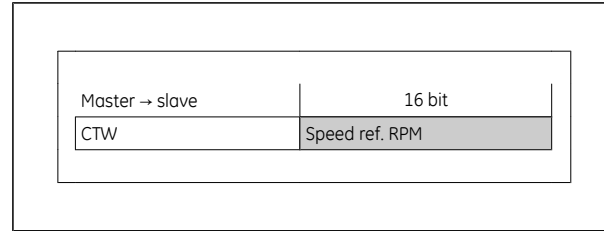

The bus reference has the following format:

100% = 4000 Hex

par. F-50 Reference Range = "0" ["ref_{MIN}" -> ref_{MAX}] 0 -> 16384 (4000 Hex) ~ 0 -> 100%

par. F-50 Reference Range = "1" [- ref_{MAX} -> + ref_{MAX}] -16384 (C000 Hex) -> +16384 (4000 Hex) ~ -100% -> +100%

4.5.4 Actual Output Frequency under Instances 100/150 and 101/151

The value of the actual output frequency of the frequency converter is transmitted in the form of a 16-bit word. The value is transmitted as a whole number (-32767 -> 32767) Negative figures are formed by means of 2's complement.

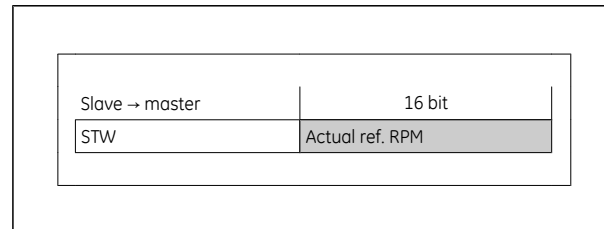

The actual output frequency has the following format:

-32767 -> +32767.

-16384 (C000 Hex) corresponds to -100%, and 16384 (4000 Hex) corresponds to 100%.





5 How to Access the Parameters

5.1 Explicit Messages

DeviceNet is based on the CAN protocol. This means that every message contains an 11-bit CAN identifier field to define the connection ID. These CAN identifiers are also used to determine access priority.

The MAC ID is stored in the header of the message, which is split into four different message groups.

10	9	8	7	6	5	4	3	2	1	0	Identifier bits		
0	Group 1 ID				Source MAC ID				Message Group 1				
1	0	MAC ID				Group 2 ID				Message Group 2			
1	1	Group 3 ID				Source MAC ID				Message Group 3			
1	1	1	1	1	Group 4 ID				Message Group 4				
1	1	1	1	1	1	1	X	X	X	X	Invalid Can Identifiers		

AF-600 FP and AF-650 GP parameters can be accessed by the Standard DeviceNet service Explicit Message. Two classes of explicit messages are supported: Message group 2: Explicit messages take place via pre-defined master/slave connections. Message group 3: Explicit messages take place via dynamically established lower prioritized connections.

5.2 Object Classes

The following Standard DeviceNet objects can be accessed:

Class ID 01h	Identity Object	Class ID 10h	Parameter Group Object
Class ID 03h	DeviceNet Object	Class ID 28h	Motor Data Object
Class ID 04h	Assembly Object	Class ID 29h	Control Supervisory Object
Class ID 05h	Connection Object	Class ID 2Ah	AC/DC Drive Object
Class ID 0Fh	Parameter Object	Class ID 2Bh	Acknowledge Handler Object

The following DeviceNet Vendor Specific Objects are also available:

Class ID 100d to 119d Drive Classes.

The above Object classes are described in the following sections: *DeviceNet Object Classes* and *Drive Object Classes*.

5.3 DeviceNet Object Classes

5.3.1 Class ID 01h Identity Object

This is a standard DeviceNet Object for identification of the device (frequency converter). The Heartbeat Interval can be set in this Object. The attributes supported for this class are listed below.

5.3.2 Class ID 01h Identity Object

This is a standard DeviceNet Object for identification of the device (frequency converter). The Heartbeat Interval can be set in this Object. The attributes supported for this class are listed below.



5.3.3 Class ID 0x01

Attribute	Access	Name	Data type	Min/Max	Units	Default	Description
1	Get	Vendor	USINT			97	Vendor Code
2	Get	Device Type	UNIT			2	AD/DC Motor
3	Get	Product Code	UNIT			100	See EDS File Section
4	Get	Revision	UNIT				Software version on AF-600 FP or AF-650 GP
5	Get	Status	UNIT				
6	Get	Serial Number	UDINT				From frequency converter
7	Get	Product Name	String				AF-600 FP or AF-650 GP
10	Get/Set	Heartbeat Interval	USINT	0-255	sec	0	Off

5

5.3.4 Class ID 03h DeviceNet Object

This is a standard DeviceNet Object for configuration and status of the DeviceNet connection.

The attributes supported for this class are listed below.

5.3.5 Class ID 0x03

Attribute	Access	Name	Data type	Min/Max	Units	Default	Description
1	Get/Set	MAC ID	USINT	0-63		63	Node address
2	Get/Set	Baud Rate	USINT	0-2		0	0=125 1=250 2=500
4	Get	BOC					Bus-Off Counter
5	Get	Allocate information					Only required if predefined Master/Slave is implemented
6	Get	MAC ID Switch changed	BOOL	0-1		0	The node address switch has changed since the last power-up/reset
7	Get	Baud rate switched from last power up	BOOL	0-1		0	The baud rate switch has changed since the last power-up

5.3.6 Class ID 04h Assembly Object

This is a standard DeviceNet Object for transfer of the I/O Instances (Process Data) described in the section "How to control the Frequency Converter". Using this it is possible to send or read any of the defined Instances, either by polling or explicit messaging.

The attributes supported for this class are listed below.

5.3.7 Class ID 0x04

Attribute	Access	Name	Data type	Min/Max	Units	Default	Description
3	Set	Data	ARRAY				



Instance	Access	Size	Description	Par. DN-10 selection:
20	Set	2 Words	DeviceNet AC/DC Profile	Instance 20/70
21	Set	2 Words	DeviceNet AC/DC Profile	Instance 21/71
70	Get	2 Words	DeviceNet AC/DC Profile	Instance 20/70
71	Get	2 Words	DeviceNet AC/DC Profile	Instance 21/71
100	Set	2 Words	Drive specific, no PCD Words	Instance 100/150
101	Set	4 Words	Drive specific, 2 PCD Words	Instance 101/151
150	Get	2 Words	Drive specific, no PCD Words	Instance 100/150
151	Get	4 Words	Drive specific, 2 PCD Words	Instance 101/151

5.3.8 Class ID 05h Connection Object

This is a standard DeviceNet Object for allocation and managing I/O and explicit messaging connections. For this class three Instances are supported: Explicit Messages, Polled I/O and Change of State connections.

The attributes supported for the different instances are listed below.

5.3.9 Instance 1 Attributes: Explicit Message Instance

Attribute	Access	Name	Data type	Description
1	Get	State	USINT	State of the object
2	Get	Instance Type	USINT	Indicates either I/O or Explicit Message
3	Get	Transport Class Trigger	USINT	Defines behaviour of the connection
4	Get	Produced Connection ID	UINT	CAN Identifier Field when the connection transmits
5	Get	Consumed Connection ID	UINT	CAN Identifier Field value that denotes message to be received
6	Get	Initial Communication Characteristics	USINT	Defines the message group(s) across which productions and consumptions associated with this connection occur
7	Get	Produced Connection size	UINT	Maximum number of bytes transmitted across this connection
8	Get	Consumed Connection size	UINT	Maximum number of bytes received across this connection
9	Get/Set	Expected Package Rate	UINT	Defines value used in Transmission Trigger Timer and Inactivity/Watchdog timer
12	Get	Watchdog timeout action	USINT	Defines how to handle Inactivity/Watchdog timeout
13	Get	Produced Connection Path Length	UINT	Number of Bytes in the produced connection path attribute
14	Get	Produced Connection Path	Array of USINT	Specifies the Application object(s) whose data is to be produced by these Connection Objects
15	Get	Consumed Connection Path Length	UINT	Number of bytes in the consumed connection path attribute
16	Get	Consumed Connection Path	Array of USINT	Specifies the Application object(s) that are to receive the data consumed by this Connection object
17	Get	Production Inhibit Time	UINT	Defines minimum time between new data production. This attribute is required for I/O Client connection.



5.3.10 Instance 2 Attributes: Polled I/O

Attribute	Access	Name	Data type	Description
1	Get	State	USINT	State of the object
2	Get	Instance Type	USINT	Indicates either I/O or Explicit Message
3	Get	Transport Class Trigger	USINT	Defines behaviour of the connection
4	Get	Produced Connection ID	UINT	CAN Identifier Field when the connection transmits
5	Get	Consumed Connection ID	UINT	CAN Identifier Field value that denotes message to be received
6	Get	Initial Communication Characteristics	USINT	Defines the message group(s) across which productions and consumptions associated with this connection occur
7	Get	Produced Connection size	UINT	Maximum number of bytes transmitted across this connection
8	Get	Consumed Connection size	UINT	Maximum number of bytes received across this connection
9	Get/Set	Expected Package Rate	UINT	Defines value used in Transmission Trigger Timer and Inactivity/Watchdog timer
12	Get	Watchdog timeout action	USINT	Defines how to handle Inactivity/Watchdog timeout
13	Get	Produced Connection Path Length	UINT	Number of Bytes in the produced connection path attribute
14	Get	Produced Connection Path	Array of USINT	Specifies the Application object(s) whose data is to be produced by these Connection Objects
15	Get	Consumed Connection Path Length	UINT	Number of bytes in the consumed connection path attribute
16	Get	Consumed Connection Path	Array of USINT	Specifies the Application object(s) that are to receive the data consumed by this Connection object
17	Get	Production Inhibit Time	UINT	Defines minimum time between new data production. This attribute is required for I/O Client connection.



5.3.11 Instance 4: Change of State/Cycle

Attribute	Access	Name	Data type	Description
1	Get	State	USINT	State of the object
2	Get	Instance Type	USINT	Indicates either I/O or Explicit Message
3	Get	Transport Class Trigger	USINT	Defines behaviour of the connection
4	Get	Produced Connection ID	UINT	CAN Identifier Field when the connection transmits
5	Get	Consumed Connection ID	UINT	CAN Identifier Field value that denotes message to be received
6	Get	Initial Communication Characteristics	USINT	Defines the message group(s) across which productions and consumptions associated with this connection occur
7	Get	Produced Connection size	UINT	Maximum number of bytes transmitted across this connection
8	Get	Consumed Connection size	UINT	Maximum number of bytes received across this connection
9	Get/Set	Expected Package Rate	UINT	Defines value used in Transmission Trigger Timer and Inactivity/Watchdog timer
12	Get	Watchdog timeout action	USINT	Defines how to handle Inactivity/Watchdog timeout
13	Get	Produced Connection Path Length	UINT	Number of Bytes in the produced connection path attribute
14	Get	Produced Connection Path	Array of USINT	Specifies the Application object(s) whose data is to be produced by these Connection Objects
15	Get	Consumed Connection Path Length	UINT	Number of bytes in the consumed connection path attribute
16	Get	Consumed Connection Path	Array of USINT	Specifies the Application object(s) that are to receive the data consumed by this Connection object
17	Get	Production Inhibit Time	UINT	Defines minimum time between new data production. This attribute is required for I/O Client connection.



5.3.12 Class ID 0F4 Parameter Object

This object is an interface to the parameters of the drive. It identifies configurable parameters and supplies their description, including min. and max. values and a descriptive text.

The attributes supported are listed below.

5

Attribute	Access	Stub/Full	Name	Data type	Description
1	Set/Get	Stub	Parameter value	Data type ¹	Actual value of parameter
2	Get	Stub	Link path size	USINT	Size of link path
3	Get	Stub	Link path	ARRAY	DeviceNet's path to parameter's origin
			Segment type/port	BYTE	
			Segment Address	Path	
4	Get	Stub	Descriptor	WORD	Description of parameter
5	Get	Stub	Data type	EPATH	Data type code
6	Get	Stub	Data size	USINT	Number of bytes in parameter value
7	Get	Full	Parameter name string	SHORT STRING	Human readable text string representing parameter name
8	Get	Full	Units string	SHORT STRING	Human readable text string representing parameter name
9	Get/Set	Full	Help string	SHORT STRING	Human readable text string representing parameter name
10	Get	Full	Min value	Data type ¹	Min valid value
11	Get	Full	Max value	Data type ¹	Max valid value
12	Get	Full	Default value	Data type ¹	Parameters default value
13	Get	Full	Scaling multiplier	UINT	Multiplier for scaling factor
14	Get	Full	Scaling divisor	UINT	Divisor for scaling factor
15	Get	Full	Scaling base	UINT	Base for scaling formula
16	Get	Full	Scaling offset	INT	Offset for scaling formula
17	Get	Full	Multiplier link	UINT	Parameter instance of multiplier source
18	Get	Full	Divisor link	UINT	Parameter instance of divisor source
19	Get	Full	Base link	UINT	Parameter instance of base source
20	Get	Full	Offset link	UINT	Parameter instance of offset source
21	Get	Full	Decimal precision	USINT	Specifies parameter value format

¹ = Same data type as the parameter.

5.3.13 Class ID 10h Parameter Group Object

This Object defines 14 parameter groups for all AF-600 FP and AF-650 GP parameters. One Class instance exists for each parameter group. A read out of an instance will contain the name of the current parameter group.

Group	Instance	Name (max. 16 characters)															
1	1	F	U	N	D	A	M	E	N	T	A	L		P	A	R	A
2	2	D	I	G	I	T	A	L		I	N		O	U	T		
3	3	F	R	E	Q	U	E	N	C	Y		C	O	N	T	R	O
4	4	M	O	T	O	R		D	A	T	A						
5	5	H	I	G	H		P	E	R	F		P	A	R	A	M	E
6	6	K	E	Y	P	A	D		S	E	T	U	P				
7	7	A	N	A	L	O	G		I	N		O	U	T			
8	8	B	R	A	K	I	N	G		F	U	N	C	T	I	O	N
9	9	O	P	T	I	O	N	S		C	O	M	M	S			
10	10	S	P	E	C	I	A	L		F	U	N	C	T	I	O	N
11	11	C	A	N		F	I	E	L	D	B	U	S				
12	12	P	I	D		C	O	N	T	R	O	L	S				



5.3.14 Class ID 28 Motor Data Object

In this object, the current motor data can be configured and read out. The Instances, attributes and services supported for this class are listed below.

5.3.15 Class ID 0/28 Motor Data Object

Attribute	Access	Name	Data type	Generic maximum values	Units	Default	Description	Parameter reference
3	Get/set	Motor type	USINT	7		7	7 = Squirrel Cage Induction Motor	par. P-20 <i>Motor Construction</i>
6	Get/set	Rated current	UNIT	0-100.00	100mA	Drive dependent	Stator Current rating (from motor nameplate)	par. P-03 <i>Motor Current</i>
7	Get/set	Rated voltage	UNIT	200-500	volt	Drive dependent	Base Voltage rating (from motor nameplate)	par. F-05 <i>Motor Rated Voltage</i>
8	Get/set	Rated power	UDINT	0-18500	Watt	Drive dependent	Power rating at rated frequency (from motor nameplate)	par. P-07 <i>Motor Power [kW]</i>
9	Get/set	Rated frequency	UNIT	1-1000	Hz	Drive dependent	Elec. frequency rating (from motor nameplate)	par. F-04 <i>Base Frequency</i>
12	Get/set	Pole count	UINT			Drive dependent	Number of poles in the motor	par. P-01 <i>Motor Poles</i>
15	Get/set	Base speed	UNIT	100-60000	RPM	Drive dependent	Nominal motor speed (from motor nameplate)	par. P-06 <i>Base Speed</i>

* only on AF-650 GP drive

5.3.16 Class ID 29h Control Supervisory Object

The Control Supervisory Object can be used for process control and monitoring of the frequency converter, as an alternative to the I/O Instances defined in the section "How to control the Frequency Converter".

The attributes supported for this class are listed below.

5.3.17 Class ID 0x29

Attribute	Access	Name	Data type	Min/Max	Default	Description
3	Get/Set	Run 1	Bool	0-1		Run Fwd, see note below
4	Get/Set	Run 2	Bool	0-1		Run rev, see note below
5	Get/Set	NetCtrl	Bool	0-1	1	0 = Local Control 1 = Control from Network
6	Get	State	USINT	0-7		0 = Vendor specific 1 = Start up 2 = Not ready 3 = Ready 4 = Enabled 5 = Stopping 6 = Fault stop 7 = Fault
7	Get	Running 1	Bool	0-1	0	0 = Other state 1 = (Enable and Run 1) or (Stopping and Running 1) or (Fault Stop and Running 1)
8	Get	Running 2	Bool	0-1	0	0 = Other state 1 = (Enable and Run 2) or (Stopping and Running 2) or (Fault Stop and Running 2)
9	Get	Ready	Bool	0-1		0 = Other state 1 = Ready or Enabled or Stopping
10	Get	Fault	Bool	0-1	0	0 = No Faults Present 1 = Fault Occured (latched)
12	Get/Set	Fault Rst	Bool	0-1		0 = No Action 1 ->1 = Reset Fault
13	Get	Fault Code	UINT			
15	Get	Ctrl From Net	Bool	0-1	1	0 = Control is local 1 = Control is from Network
16	Get/Set	DN Fault Mode	UINT	0-2	1	Action on loss of DeviceNet 0 = Fault + Stop 1 = Ignore (Warning Optional) 2 = Drive specific

NB!

The ODVA drive profile selected in par. P-20 *Motor Construction* is available only when Instances 20/70 or 21/71 are selected.



The State - Transition diagram below shows how the frequency converter will respond to the various command attributes associated with Class ID 0x29.

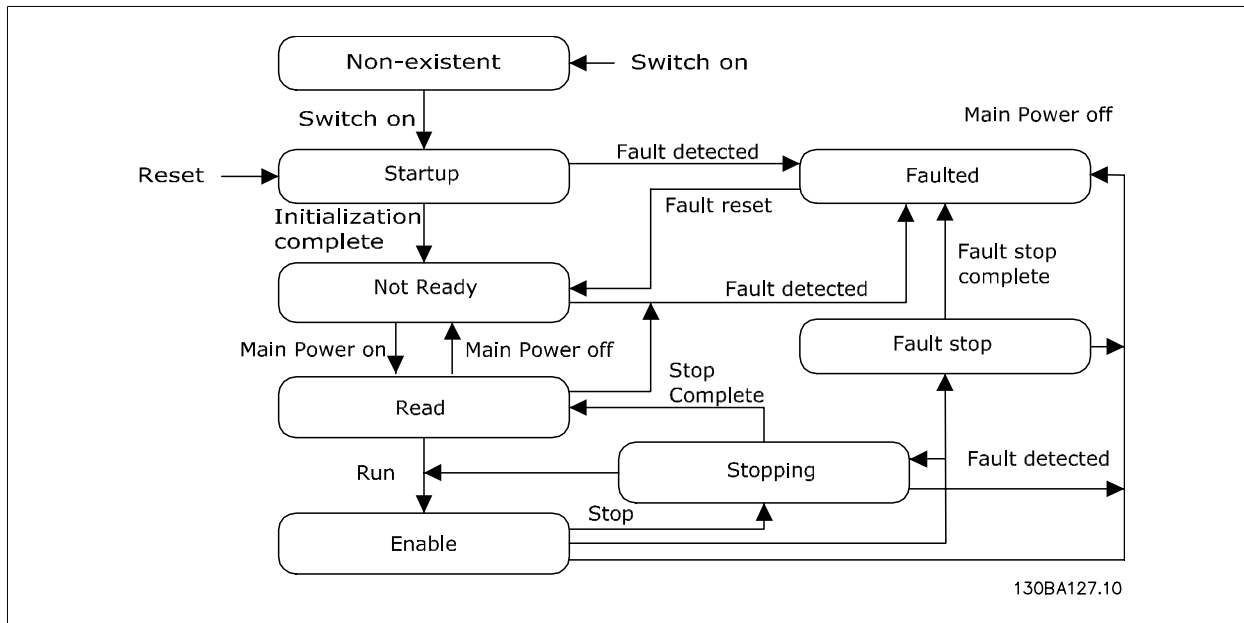

5

5.3.18 Class ID 2Ah AC/DC Drive Object

Use this object to set and read out a range of AF-600 FP or AF-650 GP drive control and status information. The attributes supported for this class are listed below.

5.3.19 Class ID 0x2A

Attribute	Access	Name	Data type	Min/Max	Default	Description
3	Get	At Reference	Bool	0-1		0 = Drive not at reference 1 = Drive at reference
4	Get/Set	Net REF	Bool	0-1	1	0 = Set reference at non-DeviceNet reference 1 = Set reference at DeviceNet reference
6	Get/Set	Drive Mode	USINT	0-1	1	0 = Vendor specific mode 1 = Open loop speed (Frequency) 2 = Closed loop speed control
7	Get	Speed Actual	INT		RPM/2 ^{Speed Scale}	Actual drive speed (best approximation)
8	Get/Set	Speed Ref	INT		RPM/2 ^{Speed Scale}	Speed reference
22	Get/Set	Speed Scale	SINT	-128-127		Speed scaling factor
29	Get	Ref from Net	Bool	0-1		0 = Local speed reference 1 = DeviceNet speed reference

5.3.20 Class ID 2Bh (Acknowledge Handler Object)

Use this object to manage message reception acknowledgements, necessary for Change-Of-State support.

The attributes supported for this class are listed below.

5.3.21 Class ID 0x2B

Attribute	Access	Name	Data type	Min/Max	Default	Description
1	Set	ACK Timer	UINT	0-65535	16	Time top wait for ACK before resending
2	Get/Set	Retry Timer	USINT	0-255	1	Number of ACK-timeouts to wait before producing. RetryLimit_Reoche event.
3	Get/Set	COS	UINT			Connection instance ID



5.4 Drive Object Classes

Use the Drive classes for read and write of all AF-600 FP or AF-650 GP parameter values. For each parameter group a corresponding object Class is defined. The following table shows the classes supported, and their relationship to the AF-600 FPAF-650 GP or AF-600 FP parameters.

The class Instance and Attribute acts in the following way:

- 100 added to the parameter group = the value for the class
- 100 added to the remaining parameter number = the value for the instance
- 100 added to the array index of the parameter = the value for the attribute.

GE Classes	
Parameter Group	Class
F-##	Class 100
E-##	Class 101
C-##	Class 102
P-##	Class 103
H-##	Class 104
K-##	Class 105
AN-##	Class 106
B-##	Class 107
O-##	Class 108
PB-##	Class 109
SP-##	Class 110
XC-##	Class 111
DR-##	Class 112
LG-##	Class 113
CL-##	Class 114
ID-##	Class 115
AP-##	Class 116
T-##	Class 117
FB-##	Class 118
PC-##	Class 119
AO-##	Class 120
BP-##	Class 121
DN-##	Class 122
PI-##	Class 123
LC-##	Class 124
EC-##	Class 125
RS-##	Class 126
BN-##	Class 127
LN-##	Class 128
EN-##	Class 129
CB-##	Class 130
CA-##	Class 131
CD-##	Class 132

NB!

Some parameter groups are only available in either the AF-650 Gp or AF-600 FP.



5.4.1 Example

Examples: (fictitious parameters)(All values in decimal)

- par. K-01 *Language* [index 0] = Class 100; Instance 101; Attribute 100
- par. H-40 *Configuration Mode* [index 0] = Class 101; Instance 100; Attribute 100
- Par. C-59 [index 0] = Class 102; Instance 159; Attribute 100
- Par. K-34 [index 3] = Class 105; Instance 134; Attribute 103
- par. AN-54 *Terminal 42 Output Timeout Preset* [index 9] = Class 106; Instance 154; Attribute 109
- par. DN-01 *Baud Rate Select* [index 0] = Class 110; Instance 101; Attribute 100



6 Parameters

O-01 Control Site

Option:
Function:

The setting in this parameter overrides the settings in par. O-50 *Coasting Select* to par. O-56 *Preset Reference Select*.

[0] *	Digital and ctrl.word	Control by using both digital input and control word.
[1]	Digital only	Control by using digital inputs only.
[2]	Controlword only	Control by using control word only.

O-02 Control Word Source

Select the source of the control word: one of two serial interfaces or four installed options. During initial power-up, the frequency converter automatically sets this parameter to *Option A* [3] if it detects a valid network option module installed in slot A. If the option is removed, the frequency converter detects a change in the configuration, sets par. O-02 *Control Word Source* back to default setting *Drive RS485*, and the frequency converter then trips. If an option is installed after initial power-up, the setting of par. O-02 *Control Word Source* will not change but the frequency converter will trip and display: *Alarm 67 Option Changed*.

This parameter cannot be adjusted while the motor is running.

Option:
Function:

[0]	None
[1]	Drive RS485
[2]	Drive USB
[3] *	Option A
[4]	Option B
[5]	Option C0
[6]	Option C1
[30]	External Can

O-03 Control Word Timeout Time

Range:
Function:

1.0 s* [0.1 - 18000.0 s]

Enter the maximum time expected to pass between the reception of two consecutive telegrams. If this time is exceeded, it indicates that the serial communication has stopped. The function selected in par. O-04 *Control Word Timeout Function* will then be carried out. The time-out counter is triggered by a valid control word.

O-04 Control Word Timeout Function

Select the time-out function. The time-out function activates when the control word fails to be updated within the time period specified in par. O-03 *Control Word Timeout Time*.

Option:
Function:

[0] *	Off	Resumes control via serial bus (Network or standard) using the most recent control word.
[1]	Freeze output	Freezes output frequency until communication resumes.
[2]	Stop	Stops with auto restart when communication resumes.
[3]	Jogging	Runs the motor at JOG frequency until communication resumes.
[4]	Max. speed	Runs the motor at maximum frequency until communication resumes.
[5]	Stop and trip	Stops the motor, then resets the frequency converter in order to restart: via the network, via the reset button on the Keypad or via a digital input.
[7]	Select setup 1	Changes the set-up upon reestablishment of communication following a control word time-out. If communication resumes causing the time-out situation to disappear, par. O-05 <i>End-of-Timeout Function</i>



		defines whether to resume the set-up used before the time-out or to retain the set-up endorsed by the time-out function.
[8]	Select setup 2	See [7] <i>Select setup 1</i>
[9]	Select setup 3	See [7] <i>Select setup 1</i>
[10]	Select setup 4	See [7] <i>Select setup 1</i>

NB!

The following configuration is required in order to change the set-up after a time-out:
Set par. K-10 *Active Set-up* to [9] *Multi set-up* and select the relevant link in par. K-12 *This Set-up Linked to*.

O-05 End-of-Timeout Function**Option:****Function:**

		Select the action after receiving a valid control word following a time-out. This parameter is active only when par. O-04 <i>Control Word Timeout Function</i> is set to [Set-up 1-4].
[0]	Hold set-up	Retains the set-up selected in par. O-04 <i>Control Word Timeout Function</i> and displays a warning, until par. O-06 <i>Reset Control Word Timeout</i> toggles. Then the frequency converter resumes its original set-up.
[1] *	Resume set-up	Resumes the set-up active prior to the time-out.

O-06 Reset Control Word Timeout

This parameter is active only when *Hold set-up* [0] has been selected in par. O-05 *End-of-Timeout Function*.

Option:**Function:**

[0] *	Do not reset	Retains the set-up specified in par. O-04 <i>Control Word Timeout Function</i> , following a control word time-out.
[1]	Do reset	Returns the frequency converter to the original set-up following a control word time-out. The frequency converter performs the reset and then immediately reverts to the <i>Do not reset</i> [0] setting

O-07 Diagnosis Trigger

This parameter has no function for DeviceNet.

Option:**Function:**

[0] *	Disable	
[1]	Trigger on alarms	
[2]	Trigger alarm/warn.	

O-10 Control Word Profile

Instances 20/70 and 21/71 are selectable in par. DN-10 *Process Data Type Selection*.

Option:**Function:**

[0] *	Drive Profile	
[1]	PROFIdrive profile	
[5]	ODVA	
[7]	CANopen DSP 402	

O-50 Coasting Select**Option:****Function:**

		Select control of the coasting function via the terminals (digital input) and/or via the network.
[0]	Digit Input	
[1]	Bus	
[2]	Logic AND	
[3] *	Logic OR	

**NB!**

This parameter is active only when par. O-01 *Control Site* is set to [0] *Digital and control word*.

O-51 Quick Stop Select

Select control of the Quick Stop function via the terminals (digital input) and/or via the network.

Option:**Function:**

[0] Digital Input

[1] Bus

[2] Logic AND

[3] * Logic OR

NB!

This parameter is active only when par. O-01 *Control Site* is set to [0] *Digital and control word*.

O-52 DC Brake Select**Option:****Function:**

Select control of the DC brake via the terminals (digital input) and/or via the network.

[0] Digit Input

[1] Bus

[2] Logic AND

[3] * Logic OR

NB!

This parameter is active only when par. O-01 *Control Site* is set to [0] *Digital and control word*.

O-53 Start Select**Option:****Function:**

Select control of the frequency converter start function via the terminals (digital input) and/or via the network.

[0] Digit Input

Activates Start command via a digital input.

[1] Bus

Activates Start command via the serial communication port or network option module.

[2] Logic AND

Activates Start command via the network/serial communication port, AND additionally via one of the digital inputs.

[3] * Logic OR

Activates Start command via the network/serial communication port OR via one of the digital inputs.

NB!

This parameter is active only when par. O-01 *Control Site* is set to [0] *Digital and control word*.

O-54 Reversing Select**Option:****Function:**

[0] Digital Input

Select control of the frequency converter reverse function via the terminals (digital input) and/or via the network.

[1] Bus

Activates the Reverse command via the serial communication port or network option module.

[2] Logic AND

Activates the Reverse command via the network/serial communication port, AND additionally via one of the digital inputs.

[3] * Logic OR

Activates the Reverse command via the network/serial communication port OR via one of the digital inputs.

**NB!**

This parameter is only active when par. O-01 *Control Site* is set to [0] *Digital and control word*.

O-55 Set-up Select**Option:****Function:**

Select control of the frequency converter set-up selection via the terminals (digital input) and/or via the network.

[0]	Digit Input	Activates the set-up selection via a digital input.
[1]	Bus	Activates the set-up selection via the serial communication port or network option module.
[2]	Logic AND	Activates the set-up selection via the network/serial communication port, AND additionally via one of the digital inputs.
[3] *	Logic OR	Activate the set-up selection via the network/serial communication port OR via one of the digital inputs.

NB!

This parameter is active only when par. O-01 *Control Site* is set to [0] *Digital and control word*.

O-56 Preset Reference Select**Option:****Function:**

Select control of the frequency converter Preset Reference selection via the terminals (digital input) and/or via the network.

[0]	Digit Input	Activates Preset Reference selection via a digital input.
[1]	Bus	Activates Preset Reference selection via the serial communication port or network option module.
[2]	Logic AND	Activates Preset Reference selection via the network/serial communication port, AND additionally via one of the digital inputs.
[3] *	Logic OR	Activates the Preset Reference selection via the network/serial communication port OR via one of the digital inputs.

NB!

This parameter is active only when par. O-01 *Control Site* is set to [0] *Digital and control word*.

O-90 Bus Jog 1 Speed**Range:****Function:**

100 RPM* [0 - par. H-13 RPM] Enter the jog speed. This is a fixed jog speed activated via the serial port or network option.

O-91 Bus Jog 2 Speed**Range:****Function:**

200 RPM* [0 - par. H-13 RPM] Enter the jog speed. This is a fixed jog speed activated via the serial port or network option.

DN-00 DeviceNet Protocol**Option:****Function:**

[0]	CANopen	
[1] *	DeviceNet	View the active CAN protocol.

NB!

The options depend on installed option.

**DN-01 Baud Rate Select**

Select the fieldbus transmission speed. The selection must correspond to the transmission speed of the master and the other network nodes.

Option: **Function:**

[16] 10 Kbps

[17] 20 Kbps

[18] 50 Kbps

[19] 100 Kbps

[20] * 125 Kbps

[21] 250 Kbps

[22] 500 Kbps

DN-02 MAC ID**Range:** **Function:**

63. N/A* [0 - 63. N/A]

Selection of station address. Every station connected to the same DeviceNet network must have an unambiguous address.

DN-05 Readout Transmit Error Counter**Range:** **Function:**

0 N/A* [0 - 255 N/A]

View the number of CAN control transmission errors since the last power-up.

DN-06 Readout Receive Error Counter**Range:** **Function:**

0 N/A* [0 - 255 N/A]

View the number of CAN control receipt errors since the last power-up.

DN-07 Readout Bus Off Counter**Range:** **Function:**

0 N/A* [0 - 255 N/A]

View the number of network Off events since the last power-up.

DN-10 Process Data Type Selection**Option:** **Function:**

Select the Instance (message) for data transmission. The Instances available are dependent upon the setting of par. O-10 *Control Word Profile*.

When par. O-10 *Control Word Profile* is set to [0] *Drive protocol*, par. DN-10 *Process Data Type Selection* options [0] and [1] are available.

When par. O-10 *Control Word Profile* is set to [5] *ODVA*, par. DN-10 *Process Data Type Selection* options [2] and [3] are available.

Instances 100/150 and 101/151 are GE-specific. Instances 20/70 and 21/71 are ODVA-specific AC Drive profiles.

For guidelines in message selection, please refer to the DeviceNet Operating Instructions.

Note that a change to this parameter will be executed immediately.

[0] * INSTANCE 100/150

[1] INSTANCE 101/151

[2] INSTANCE 20/70

[3] INSTANCE 21/71

DN-11 Process Data Config Write

Select the process write data for I/O Assembly Instances 101/151. Elements [2] and [3] of this array can be selected. Elements [0] and [1] of the array are fixed.

Option: **Function:**

Select the process write data for I/O Assembly Instances 101/151. Elements [2] and [3] of this array can be selected. Elements [0] and [1] of the array are fixed.

**DN-12 Process Data Config Read**

Select the process read data for I/O Assembly Instances 101/151. Elements [2] and [3] of this array can be selected. Elements [0] and [1] of the array are fixed.

Option:**Function:****DN-13 Warning Parameter****Range:**

0 N/A* [0 - 65535 N/A]

Function:

View a DeviceNet-specific Warning word. One bit is assigned to every warning.

Bit:	Meaning:
0	Bus not active
1	Explicit connection timeout
2	I/O connection
3	Retry limit reached
4	Actual is not updated
5	Network off
6	I/O send error
7	Initialization error
8	No bus supply
9	Bus off
10	Error passive
11	Error warning
12	Duplicate MAC ID Error
13	RX queue overrun
14	TX queue overrun
15	Network overrun

DN-14 Net Reference

Read only from Keypad

Option:**Function:**

Select the reference source in Instance 21/71 and 20/70.

[0] * Off

Enables reference via analog/digital inputs.

[1] On

Enables reference via the network.

DN-15 Net Control

Read only from Keypad

Option:**Function:**

Select the control source in Instance 21/71 and 20-70.

[0] * Off

Enables control via analog/digital inputs.

[1] On

Enable control via the network.

DN-20 COS Filter 1**Range:**

0 N/A* [0 - 65535 N/A]

Function:

Sets up the filter mask for the status word. When operating in COS (Change-Of-State), it is possible to filter out bits in the status word that should not be sent if they change.

DN-21 COS Filter 2**Range:**

0 N/A* [0 - 65535 N/A]

Function:

Sets up the filter mask for the Main Actual Value. When operating in COS (Change-Of-State), it is possible to filter out bits in the Main actual value that should not be sent if they change.

DN-22 COS Filter 3**Range:**

0 N/A* [0 - 65535 N/A]

Function:

Sets up the filter mask for PCD 3. When operating in COS (Change-Of-State), it is possible to filter out bits in PCD 3 that should not be sent if they change.

**DN-23 COS Filter 4****Range:**

0 N/A* [0 - 65535 N/A]

Function:

Sets up the filter mask for PCD 4. When operating in COS (Change-Of-State), it is possible to filter out bits in PCD 4 that should not be sent if they change.

DN-31 Store Data Values**Option:**

[0] * Off

[1] Store all setups

[2] Store all setups

Function:

This parameter is used to activate a function that stores all parameter values in the non-volatile memory thus retaining changed parameter values at power down.

The store function is inactive.

DN-33 Store Always

This parameter is used to select whether parameter data received via the DeviceNet option should always be stored in non-volatile memory.

Option:

[0] * Off

[1] On

Function:**DR-90 Alarm Word****Range:**

0 N/A* [0 - 4294967295 N/A]

Function:

View the alarm word sent via the serial communication port in hex code.

DR-92 Warning Word**Range:**

0 N/A* [0 - 4294967295 N/A]

Function:

View the warning word sent via the serial communication port in hex code.



6.2 Parameter List

Par. No. # and Description	Default value	Range	Conversion index	Data type
Par. O-00 Enabled options	All [1]	[0 - 7]	-	5
par. O-01 Control Site	Dig. & ctrl. word [0]	[0 - 2]	-	5
par. O-02 Control Word Source	Drive RS485 [0]	[0 - 4]	-	5
par. O-03 Control Word Timeout Time	1s	0.1-18000	-1	7
par. O-04 Control Word Timeout Function	Off [0]	[0 - 10]	-1	5
par. O-05 End-of-Timeout Function	Hold set-up [0]	[0 - 1]	-	5
par. O-06 Reset Control Word Timeout	Do not reset [0]	[0 - 1]	-	5
par. O-07 Diagnosis Trigger	Disable [0]	[0 - 3]	-	5
par. O-10 Control Word Profile	Drive protocol [0]	[0 - x]	-	5
par. O-50 Coasting Select	Logic OR [3]	[0 - 3]	-	5
par. O-51 Quick Stop Select	Logic OR [3]	[0 - 3]	-	5
par. O-52 DC Brake Select	Logic OR [3]	[0 - 3]	-	5
par. O-53 Start Select	Logic OR [3]	[0 - 3]	-	5
par. O-54 Reversing Select	Logic OR [3]	[0 - 3]	-	5
par. O-55 Set-up Select	Logic OR [3]	[0 - 3]	-	5
par. O-56 Preset Reference Select	Logic OR [3]	[0 - 3]	-	5
par. O-90 Bus Jog 1 Speed	100 rpm	0 - par. F-17 Motor Speed High Limit [RPM]	67	6
par. O-91 Bus Jog 2 Speed	200 rpm	0 - par. F-17 Motor Speed High Limit [RPM]	67	6
par. DN-00 DeviceNet Protocol	DeviceNet [1]	[0 - 1]	-	5
par. DN-01 Baud Rate Select	125 Kbps [20]	[20 - 22]	-	5
par. DN-02 MAC ID	63	0 - 63	0	5
par. DN-05 Readout Transmit Error Counter	0	0 - 255	0	5
par. DN-06 Readout Receive Error Counter	0	0 - 255	0	6
par. DN-07 Readout Bus Off Counter	0	0 - 1000	0	5
par. DN-10 Process Data Type Selection	[0]/[2]	[0 - 3]	0	5
par. DN-11 Process Data Config Write	0	list	0	5
par. DN-12 Process Data Config Read	0	list	0	5
par. DN-13 Warning Parameter	0	0 - FFFF	0	5
par. DN-14 Net Reference	Off [0]	[0 - 1]	-	5
par. DN-15 Net Control	Off [0]	[0 - 1]	-	5
par. DN-20 COS Filter 1	0	0 - FFFF	0	6
par. DN-21 COS Filter 2	0	0 - FFFF	0	6
par. DN-22 COS Filter 3	0	0 - FFFF	0	6
par. DN-23 COS Filter 4	0	0 - FFFF	0	6
par. DN-31 Store Data Values	Off [0]	[0 - 2]	-	5
par. DN-32 Devicenet Revision	-	-	-	6
par. DN-33 Store Always	Off [0]	[0 - 1]	-	5
par. DR-90 Alarm Word	0	0 - FFFF	0	7
par. DR-92 Warning Word	0	0 - FFFF	0	7



6.3 Data Types Supported

6.3.1 Object and Data Types Supported

Data types supported

Data type	Description
3	Integer 16
4	Integer 32
5	Unsigned 8
6	Unsigned 16
7	Unsigned 32
9	Visible string
10	Byte string
33	Standardized value (16 bit)
35	Bit sequence
41	Byte
42	Word

6

6.3.2 Conversion Index

This number refers to a conversion figure used when writing or reading to parameters.

Conversion index	Conversion factor
100	1
67	1/60
6	1000000
5	100000
4	10000
3	1000
2	100
1	10
0	1
-1	0.1
-2	0.01
-3	0.001
-4	0.0001
-5	0.00001
-6	0.000001





7 Application Examples

7.1 Example: Working with Instance 101/151 Process

This example shows how to work with I/O Instance 101/151, which consists of Control Word/Status Word and Reference/Main Actual Value. The Instance 101/151 also has two additional words, which can be programmed to monitor process signals, as shown in the figure.

The application requires monitoring of the motor torque and digital input, so PCD 3 is set up to read the actual motor torque. PCD 4 is set up to monitor the state of an external sensor via the process signal digital input. The sensor is connected to digital input 18.

An external device is also controlled via control word bit 11 and the built-in relay of the frequency converter.

Reversing is permitted only when the reversing bit 15 in the control word and the digital input 19 are set to high.

For safety reasons the frequency converter will stop the motor if the Device-Net cable is broken, the master has a system failure, or the PLC is in stop mode.

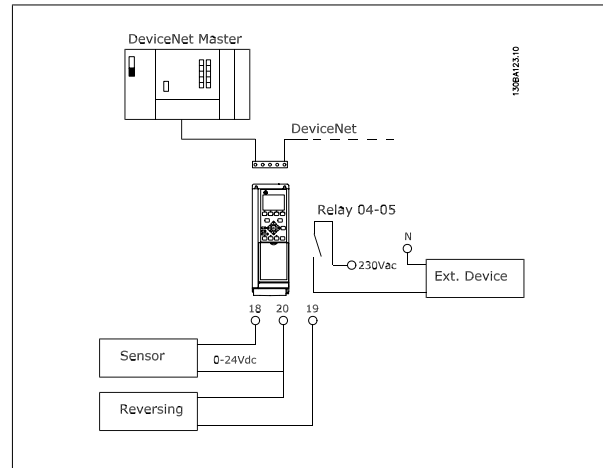

Parameter	Function	Setting
par. H-08 Reverse Lock	Motor speed range/direction	Both directions [2]
par. E-01 Terminal 18 Digital Input	Digital input 18	No operation [0]
par. E-02 Terminal 19 Digital Input	Digital input 19	Reversing [10]
par. E-24 Function Relay	Function relay	Control word bit 11 [36] Control word bit 12 [37]
par. O-03 Control Word Timeout Time	Control word timeout time	1.0 sec
par. O-04 Control Word Timeout Function	Control word timeout function	Stop [2]
par. O-10 Control Word Profile	Control word profile	Drive Profile
par. O-50 Coasting Select	Coasting select	Bus [1]
par. O-51 Quick Stop Select	Quick-stop select	Bus [1]
par. O-52 DC Brake Select	DC-brake select	Bus [1]
par. O-53 Start Select	Start select	Bus [1]
par. O-54 Reversing Select	Reversing select	Logic AND [2]
par. O-55 Set-up Select	Set-up select	Bus [1]
par. O-56 Preset Reference Select	Preset reference select	Bus [1]
par. DN-01 Baud Rate Select	Baud rate select	- set to match other DeviceNet stations
par. DN-02 MAC ID	MAC ID	- set desired station address
par. DN-10 Process Data Type Selection	Process data type selection	Instance 101/151 [1]
par. DN-12 Process Data Config Read	Process Data Config Read	PCD 3: Torque PCD 4: Digital input



7.1.1 Example of PLC Programming

In this example Instance 101/151 is placed in the following Input/Output address:

Input address	0.0-0.15	0.16-0.31	1.0-1.15	1.16-1.31
Set-up	Status word	MAV	Motor torque	Digital input

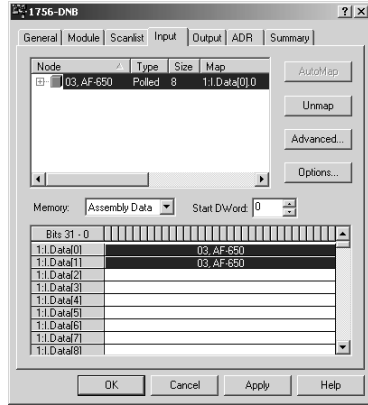

130BA131.10

7

Output address	0.0-0.15	0.16-0.31	1.0-1.15	1.16-1.31
Set-up	Control word	Reference	Not used	Not used

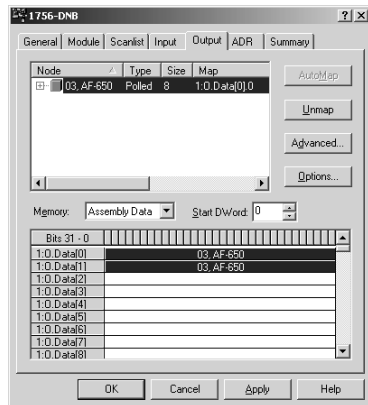

130BA132.10



8 Troubleshooting

8.1 Troubleshooting

8.1.1 LED Status

First, check the LEDs.

The DeviceNet control card contains two bi-colour (green/red) LEDs to indicate the state of the device and the network respectively.

The upper LED indicates module status (MS). The lower LED indicates network status (NS).

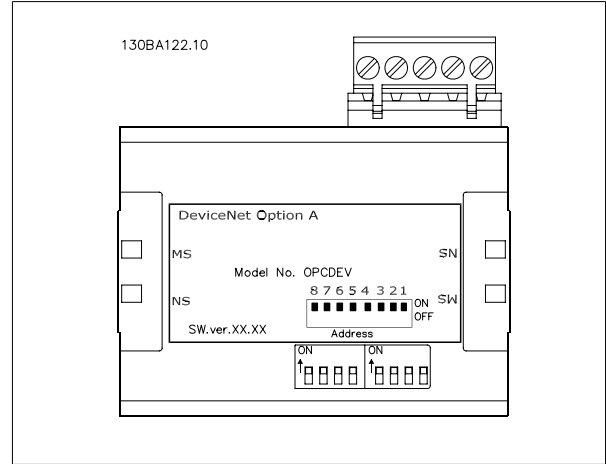

State	Bi-colour LED	Status
No Power	Off	There is no power applied to the option
Device operational	Green	The DeviceNet option is operating in normal condition.
Standby	Green	The DeviceNet option needs commissioning due to configuration missing, incomplete or incorrect.
Minor fault	Red	Recoverable fault.
Unrecoverable fault	Red	Unrecoverable fault, may need replacing.
Self test	Green	The DeviceNet option is in Self-test mode.
	Red	

Table 8.1: LED: Module Status (MS)

State	Bi-colour LED	Status
No Power/Not on-line	Off	The option has not completed "Duplicate MAC ID" test yet or may not be powered.
On-line, not connected	Green	The option is on-line, but not allocated to a master.
On-line and connected	Green	The DeviceNet option is on-line and connected to a master.
Connection time-out	Red	One or more I/O connections are in time-out state.
Critical link failure	Red	

Table 8.2: LED: Network Status (NS)



8.1.2 No Communication with the Drive

If there is no communication with the drive, proceed with the following checks:

Check 1: Is the cabling correct?

Check that the cables are connected to the correct terminals as shown in the diagram.

Pin no.	Terminal	Colour	Name
1	V-	Black	GND
2	CAN_L	Blue	CAN LOW
3	Drain	(bare)	Screen
4	CAN_H	White	CAN HIGH
5	V+	Red	+24 V

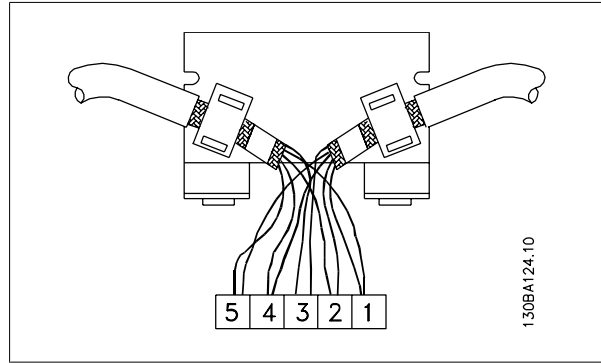

Check 2: Is the 24V network voltage applied?

Check 3: Is the correct EDS file installed?

Download the correct EDS file from <http://www.geelectrical.com/drives>.

Check 4: Is the bus connection terminated at both ends?

If not, terminate the bus connection with termination resistors at the initial and final nodes, as shown in the following diagram. Termination is performed between terminal 2 (CAN_L) and 4 (CAN_H) with a resistor: 121 Ohm, 1% metal film, ¼ Watt.

8

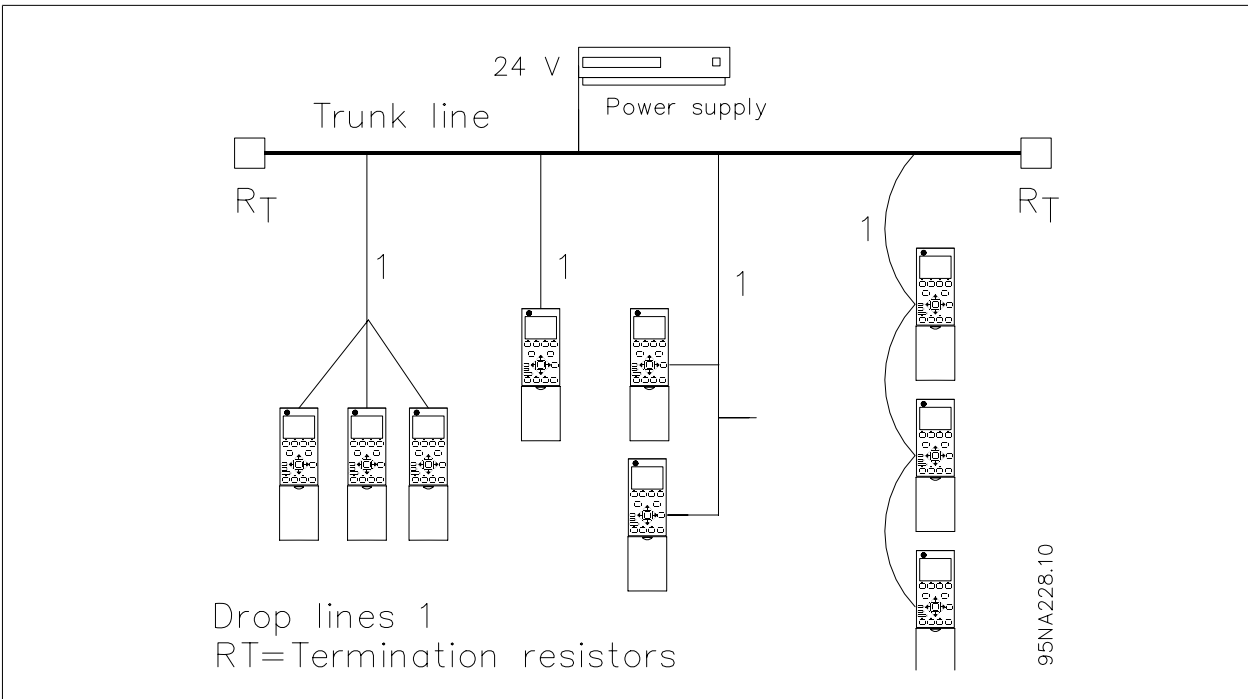



8.1.3 Drive Will Not Respond to Control Signals

- GE Drive Control Word profile (instances 100/150 and 101/151)

Check 1: Is the Control word valid?

If bit 10=0 in the Control word, then the frequency converter will not accept the Control word, because the default setting is bit 10=1. Set bit 10=1 via the PLC.

Check 2: Is the relationship between bits in the Control word and the terminal I/Os correct?

Check the logical relationship in the frequency converter.

Set the logic to bit 3=1 AND digital input=1 in order to achieve a successful start.

Define the desired logical relationship in par. O-50 *Coasting Select* to par. O-56 *Preset Reference Select* according to the following range of options. Select the drive control mode, digital input and/or bus communication, using par. O-50 *Coasting Select* to par. O-56 *Preset Reference Select*.

The tables below show the effect upon the frequency converter of a coast command for the full range of par. O-50 *Coasting Select* settings.

The effect of control mode upon the function of par. O-50 *Coasting Select*, par. O-51 *Quick Stop Select* and par. O-52 *DC Brake Select* is as follows:

If *Digital input [0]* is selected, the terminals will control the Coast and DC Brake functions.

Par. O-50/51/52 setting: Digital Input [0]		
Terminal	Bit 02/03/04	Function
0	0	Coast/DC brake/Q-Stop
0	1	Coast/DC brake/Q-Stop
1	0	No Coast/DC brake/Q-Stop
1	1	No Coast/DC brake/Q-Stop

If *Bus [1]* is selected, commands will be activated only when given via the control word.

Par. O-50/51/52 setting: Bus [1]		
Terminal	Bit 02/03/04	Function
0	0	Coast/DC brake/Q-Stop
0	1	No Coast/DC brake/Q-Stop
1	0	Coast/DC brake/Q-Stop
1	1	No Coast/DC brake/Q-Stop

If *Logic AND [2]* is selected, both signals must be activated to perform the function.

Par. O-50/51/52 setting: Logic AND [2]		
Terminal	Bit 02/03/04	Function
0	0	Coast/DC brake/Q-Stop
0	1	No Coast/DC brake/Q-Stop
1	0	No Coast/DC brake/Q-Stop
1	1	No Coast/DC brake/Q-Stop

If *Logic OR [3]* is selected, activation of one signal will activate the function.

Par. O-50/51/52 setting: Logic OR [3]		
Terminal	Bit 02/03/04	Function
0	0	Coast/DC brake/Q-Stop
0	1	Coast/DC brake/Q-Stop
1	0	Coast/DC brake/Q-Stop
1	1	No Coast/DC brake/Q-Stop

NB!

Please note that Coasting, Quick Stop and DC brake functions are active for logic "0".



The effect of control mode upon the function of par. O-53 *Start Select* and par. O-54 *Reversing Select*:

If *Digital Input* [0] is selected, the terminals will control the start and reversing functions

Par. O-53/54 setting: Digital input [0]		
Terminal	Bit 06/15	Function
0	0	Stop/Anti-clockwise
0	1	Stop/Anti-clockwise
1	0	Start/Clockwise
1	1	Start/Clockwise

If *Bus* [1] is selected, commands will be activated only when given via the control word.

Par. O-53/54 setting: Bus [1]		
Terminal	Bit 02/03/04	Function
0	0	Stop/Anti-clockwise
0	1	Start/Clockwise
1	0	Stop/Anti-clockwise
1	1	Start/Clockwise

If *Logic AND* [2] is selected, both signals must be activated to perform the function.

Par. O-53/54 setting: Logic AND [2]		
Terminal	Bit 02/03/04	Function
0	0	Stop/Anti-clockwise
0	1	Stop/Anti-clockwise
1	0	Stop/Anti-clockwise
1	1	Start/Clockwise

If *Logic OR* [3] is selected, activation of one signal will activate the function.

Par. O-53/54 setting: Logic OR [3]		
Terminal	Bit 02/03/04	Function
0	0	Stop/Anti-clockwise
0	1	Start/Clockwise
1	0	Start/Clockwise
1	1	Start/Clockwise

8

The effect of control mode upon the function of par. O-55 *Set-up Select* and par. O-56 *Preset Reference Select*:

If *Digital input* [0] is selected, the terminals will control the set-up and preset reference functions.

Par. O-55/56 setting: Digital input [0]				
Terminal		Bit 00/01, 13/14		Function
Msb	Lsb	Msb	Lsb	Preset ref., Set-up no.
0	0	0	0	1
0	0	0	1	1
0	0	1	0	1
0	0	1	1	1
0	1	0	0	2
0	1	0	1	2
0	1	1	0	2
0	1	1	1	2
1	0	0	0	3
1	0	0	1	3
1	0	1	0	3
1	0	1	1	3
1	1	0	0	4
1	1	0	1	4
1	1	1	0	4
1	1	1	1	4



If *Bus* [1] is selected, commands will be activated only when given via the control word.

Par. O-55/56 setting: Bus [1]				
Terminal		Bit 00/01, 13/14		Function
Msb	Lsb	Msb	Lsb	Preset ref., Set-up no.
0	0	0	0	1
0	0	0	1	2
0	0	1	0	3
0	0	1	1	4
0	1	0	0	1
0	1	0	1	2
0	1	1	0	3
0	1	1	1	4
1	0	0	0	1
1	0	0	1	2
1	0	1	0	3
1	0	1	1	4
1	1	0	0	1
1	1	0	1	2
1	1	1	0	3
1	1	1	1	4

If *Logic AND* [2] is selected, both signals must be activated to perform the function.

Par. O-55/56: Logic AND [2]				
Terminal		Bit 00/01, 13/14		Function
Msb	Lsb	Msb	Lsb	Preset ref., Set-up no.
0	0	0	0	1
0	0	0	1	1
0	0	1	0	1
0	0	1	1	1
0	1	0	0	1
0	1	0	1	2
0	1	1	0	1
0	1	1	1	2
1	0	0	0	1
1	0	0	1	1
1	0	1	0	3
1	0	1	1	3
1	1	0	0	1
1	1	0	1	2
1	1	1	0	3
1	1	1	1	4

If *Logic OR* [3] is selected, activation of one signal will activate the function.

Par. O-55/56 setting: Logic OR [3]				
Terminal		Bit 00/01, 13/14		Function
Msb	Lsb	Msb	Lsb	Preset ref., Set-up no.
0	0	0	0	1
0	0	0	1	2
0	0	1	0	3
0	0	1	1	4
0	1	0	0	2
0	1	0	1	2
0	1	1	0	4
0	1	1	1	4
1	0	0	0	3
1	0	0	1	4
1	0	1	0	3
1	0	1	1	4
1	1	0	0	4
1	1	0	1	4
1	1	1	0	4



8.1.4 Alarm Word and Warning Word

Alarm word and Warning word are shown on the display in Hex format. If there is more than one warning or alarm, a sum of all warnings or alarms will be shown. Alarm word and warning word can also be displayed using the field bus in par. DR-05 *Main Actual Value [%]*.

AF-650 GP or AF-600 FP				
Bit (Hex)	Alarm word (par. DR-90 <i>Alarm Word</i>)	Alarm no.	Major / minor alarm	Recoverable / unrecoverable alarm
00000001	Unused	-	-	-
00000002	Drive over temperature	29	Major	Recoverable
00000004	Earth fault	14	Major	Unrecoverable
00000008	Unused	-	-	-
00000010	Control word timeout	18	Minor	Recoverable
00000020	Over current	13	Major	Unrecoverable
00000040	Torque limit	12	Major	Recoverable
00000080	Motor thermistor over temp.	11	Major	Recoverable
00000100	Motor Thermal Electronic Overload over temperature	10	Major	Recoverable
00000200	Drive overloaded	9	Major	Recoverable
00000400	DC link under voltage	8	Major	Recoverable
00000800	DC link over voltage	7	Major	Recoverable
00001000	Short circuit	16	Major	Unrecoverable
00002000	Inrush fault	33	Major	Recoverable
00004000	Mains phase loss	4	Major	Unrecoverable
00008000	Auto Tune not OK	50	Major	Recoverable
00010000	Live zero error	2	Major	Recoverable
00020000	Internal fault	38	Major	Unrecoverable
00040000	Brake resistor power limit	26	Major	Unrecoverable
00080000	Motor phase U is missing	30	Major	Unrecoverable
00100000	Motor phase V is missing	31	Major	Unrecoverable
00200000	Motor phase W is missing	32	Major	Unrecoverable
00400000	Fieldbus comm. fault	34	Major	Recoverable
00800000	24 V supply fault	47	Major	Unrecoverable
01000000	Mains failure	36	Major	Recoverable
02000000	1.8 V supply fault	48	Major	Unrecoverable
04000000	Brake resistor short circuit	25	Major	Recoverable
08000000	Brake chopper fault	27	Major	Recoverable
10000000	Unused	-	-	-
20000000	Unused	-	-	-
40000000	Unused	-	-	-
80000000	Unused	-	-	-



AF-650 GP or AF-600 FP		
Bit (Hex)	Warning word (par. DR-92 <i>Warning Word</i>)	Warning no.
00000001	Unused	-
00000002	Drive over temperature	29
00000004	Earth fault	14
00000008	Unused	-
00000010	Control word timeout	18
00000020	Over current	13
00000040	Torque limit	12
00000080	Motor thermistor over temp.	11
00000100	Motor Thermal Electronic Overload over temperature	10
00000200	Drive overloaded	9
00000400	DC link under voltage	8
00000800	DC link over voltage	7
00001000	DC link voltage low	6
00002000	DC link voltage high	5
00004000	Mains phase loss	4
00008000	No motor	3
00010000	Live zero error	2
00020000	10 V low	1
00040000	Brake resistor power limit	26
00080000	Brake resistor short circuit	25
00100000	Brake chopper fault	27
00200000	Speed limit	49
00400000	Network comm. fault	34
00800000	24 V supply fault	47
01000000	Mains failure	36
02000000	Current limit	59
04000000	Unused	-
08000000	Unused	-
10000000	Unused	-
20000000	Unused	-
40000000	Unused	-
80000000	Warning word 2 (ext. stat. word)	-

8.2 Alarm/Warning Limits

8.2.1 Warnings and Alarm Messages

There is a clear distinction between alarms and warnings. In the event of an alarm, The frequency converter will enter a fault condition. After the cause for the alarm has been cleared, the master will have to acknowledge the alarm message for the frequency converter to start operating again. A warning on the other hand may come when a warning condition appears, and disappear when conditions return to normal without interfering with the process.

8.2.2 Warnings

All warnings within the frequency converter are represented by a single bit within a warning word. A warning word is always an action parameter. Bit status FALSE [0] means no warning, while bit status TRUE [1] means warning. To each bit and each bit status there is a corresponding text string. In addition to the warning word message the master will also be notified through a change of bit 7 in the Status Word.

8.2.3 Alarms

Following an Alarm message, the frequency converter will enter Fault condition. Only after the fault has been alleviated and the master has acknowledged the alarm message by setting bit 3 in the Control Word, can the frequency converter resume operation. All alarms within the frequency converter are represented by a single bit within an alarm word. An alarm word is always an action parameter. Bit status FALSE [0] means no alarm, while bit status TRUE [1] means alarm.



Index

A

Abbreviations	6
Alarm Word DR-90	43, 54
Alarms	55

B

Baud Rate Select DN-01	41
Bus Jog 1 Speed O-90	40
Bus Jog 2 Speed O-91	40

C

Cable Lengths	7
Cable Specifications	7
Change Of State, Cos	15
Coasting Select O-50	38
Configuration	37
Connection Of The Cable Screen	8
Control Site O-01	37
Control Word Profile O-10	38
Control Word Source O-02	37
Control Word Timeout Function O-04	37
Control Word Timeout Time O-03	37
Conversion Index	45
Cos Filter 1 DN-20	42
Cos Filter 2 DN-21	42
Cos Filter 3 DN-22	42
Cos Filter 4 DN-23	43

D

Dc Brake Select O-52	39
Devicenet Connection	9
Devicenet Object Classes	27
Devicenet Protocol DN-00	40
Devicenet Termination	9
Diagnosis Trigger O-07	38
Drive Control Profile	1
Drive Object Classes	35
Drive Will Not Respond To Control Signals	51
Drop Cable	9

E

Earth Connection	9
Eds File	13
Emc Precautions	8
End-of-timeout Function O-05	38

F

Frequency Converter Parameters	13
--------------------------------	----

I

I/o Assembly Instances	16
Installation Of Option In The Frequency Converter	10

L

Led Status	49
Leds	13

M

Mac Id DN-02	41
--------------	----

**N**

Net Control DN-15	42
Net Reference DN-14	42
Network Power Consumption	10
No Communication With The Drive	50

O

Object And Data Types Supported	45
Odva Control Profile	17
Odva Recommendation	8

P

Polling	15
Preset Reference Select O-56	40
Process Data Config Read DN-12	42
Process Data Config Write DN-11	41
Process Data Type Selection DN-10	41

Q

Quick Stop Select O-51	39
------------------------	----

R

Readout Bus Off Counter DN-07	41
Readout Receive Error Counter DN-06	41
Readout Transmit Error Counter DN-05	41
Reset Control Word Timeout O-06	38
Reversing Select O-54	39

S

Safety Note	4
Setting The Devicenet Address	11
Setting The Devicenet Baud Rate	12
Set-up Select O-55	40
Start Select O-53	39
Store Always DN-33	43
Store Data Values DN-31	43

T

Topology	5
----------	---

W

Warning Parameter DN-13	42
Warning Word	54
Warning Word DR-92	43
Warnings	55

The instructions do not purport to cover all details or variations in equipment nor to provide for every possible contingency to be met in connection with installation, operation or maintenance. Should further information be desired or should particular problems arise which are not covered sufficiently for the purchaser's purposes, the matter should be referred to the GE company.

AF-600 FP and AF-650 GP are trademarks of the General Electric Company.

GE Consumer & Industrial
41 Woodford Avenue
Plainville, CT 06062

www.geelectrical.com/drives



imagination at work

130R0138

MG11Y102



DET-623