



Instruction Manual



BAS-SVX19D-EN

June 2013

BAS-SVX19D-EN

Safety

⚠️ WARNING

HIGH VOLTAGE!

Adjustable frequency drives contain high voltage when connected to AC line power. Installation, start-up, and maintenance should be performed by qualified personnel only. Failure to perform installation, start-up, and maintenance by qualified personnel could result in death or serious injury.

High Voltage

Adjustable frequency drives are connected to hazardous AC line voltage. Extreme care should be taken to protect against shock. Only trained personnel familiar with electronic equipment should install, start, or maintain this equipment.

⚠️ WARNING

UNINTENDED START!

When the adjustable frequency drive is connected to AC line power, the motor may start at any time. The adjustable frequency drive, motor, and any driven equipment must be in operational readiness. Failure to be in operational readiness when the adjustable frequency drive is connected to AC line power could result in death, serious injury, equipment, or property damage.

Unintended Start

When the adjustable frequency drive is connected to the AC line power, the motor may be started by means of an external switch, a serial bus command, an input reference signal, or a cleared fault condition. Use appropriate caution to guard against an unintended start.

⚠️ WARNING

DISCHARGE TIME!

Adjustable frequency drives contain DC link capacitors that can remain charged even when the adjustable frequency drive is not powered. To avoid electrical hazards, disconnect AC line power, any permanent magnet type motors, and any remote DC link power supplies, including battery backups, UPS and DC link connections to other adjustable frequency drives. Wait for the capacitors to fully discharge before performing any service or repair work. The wait time required is listed in the *Discharge Time* table. Failure to wait for the specified period of time after power has been removed to do service or repair could result in death or serious injury.

Voltage [V]	Minimum waiting time [minutes]		
	4	7	15
200–240	1.5-5 hp [1.1-3.7 kW]		7.5–60 hp [5.5–45 kW]
380–480	1.5-10 hp [1.1-7.5 kW]		15–125 hp [11–90 kW]
525–600	1.5-10 hp [1.1-7.5 kW]		15–125 hp [11–90 kW]
525–690		1.5-10 hp [1.1-7.5 kW]	15–125 hp [11–90 kW]

High voltage may be present even when the warning LED indicator lights are off.

Discharge Time

Symbols

The following symbols are used in this manual.

⚠️ WARNING

Indicates a potentially hazardous situation which, if not avoided, could result in death or serious injury.

⚠️ CAUTION

Indicates a potentially hazardous situation which, if not avoided, may result in minor or moderate injury. It may also be used to alert against unsafe practices.

CAUTION

Indicates a situation that may result in equipment or property damage-only accidents.

NOTE!

Indicates highlighted information that should be observed in order to avoid mistakes or operate equipment at less than optimal performance.



Approvals

NOTE!

**Imposed limitations on the output frequency
(due to export control regulations):**

From software version 6.72, the output frequency of the adjustable frequency drive is limited to 590 Hz.

Contents

1 Introduction	2-1
1.1 Available Literature	2-1
1.2 Purpose of the Manual	2-4
1.3 Additional Resources	2-4
1.4 Product Overview	2-4
1.5 Internal Adjustable Frequency Drive Controller Functions	2-4
1.6 Frame Sizes and Power Ratings	2-5
1.7 Adjustable Frequency Drive Identification	2-6
2 Installation	3-1
2.1 Installation Site Checklist	3-1
2.2 Adjustable Frequency Drive and Motor Pre-installation Checklist	3-1
2.3 Mechanical Installation	3-1
2.3.1 Cooling	3-1
2.3.2 Lifting	3-2
2.3.3 Mounting	3-2
2.3.4 Tightening Torques	3-2
2.4 Electrical Installation	3-3
2.4.1 Requirements	3-5
2.4.2 Grounding Requirements	3-6
2.4.2.1 Leakage Current (>3.5 mA)	3-6
2.4.2.2 Grounding Using Shielded Cable	3-7
2.4.3 Motor Connection	3-7
2.4.3.1 Motor Connection for A2 and A3	3-8
2.4.3.2 Motor Connection for A4/A5	3-9
2.4.3.3 Motor Connection for B1 and B2	3-9
2.4.3.4 Motor Connection for C1 and C2	3-10
2.4.4 AC Line Input Connection	3-10
2.4.5 Control Wiring	3-10
2.4.5.1 Access	3-11
2.4.5.2 Control Terminal Types	3-11
2.4.5.3 Wiring to Control Terminals	3-13
2.4.5.4 Using Shielded Control Cables	3-13
2.4.5.5 Control Terminal Functions	3-14
2.4.5.6 Jumper Terminals 12 and 27	3-14
2.4.5.7 Terminal 53 and 54 Switches	3-14
2.4.6 Serial Communication	3-15

3 Start-up and Functional Testing	4-1
3.1 Pre-start	4-1
3.1.1 Safety Inspection	4-1
3.2 Applying Power	4-3
3.3 Basic Operational Programming	4-3
3.4 Asynchronous Motor Set-up	4-4
3.5 PM Motor Set-up	4-4
3.6 Automatic Motor Adaptation	4-6
3.7 Check Motor Rotation	4-6
3.8 Local Control Test	4-6
3.9 System Start-up	4-7
3.10 Acoustic Noise or Vibration	4-7
4 User Interface	5-1
4.1 Keypad	5-1
4.1.1 LCP Layout	5-1
4.1.2 Setting LCP Display Values	5-2
4.1.3 Display Menu Keys	5-2
4.1.4 Navigation Keys	5-3
4.1.5 Operation Keys	5-3
4.2 Back-up and Copying Parameter Settings	5-4
4.2.1 Uploading Data to the LCP	5-4
4.2.2 Downloading Data from the LCP	5-4
4.3 Restoring Default Settings	5-4
4.3.1 Recommended Initialization	5-5
4.3.2 Manual Initialization	5-5
5 About Adjustable Frequency Drive Programming	6-1
5.1 Introduction	6-1
5.2 Programming Example	6-1
5.3 Control Terminal Programming Examples	6-2
5.4 International/North American Default Parameter Settings	6-3
5.5 Parameter Menu Structure	6-4
5.5.1 Quick Menu Structure	6-5
5.5.2 Main Menu Structure	6-7
5.6 Dedicated Factory Settings	6-11
5.7 Remote Programming with Trane Drive Utility (TDU)	6-12
6 Application Set-up Examples	7-1

6.1 Introduction	7-1
6.2 Application Examples	7-1
7 Status Messages	8-1
7.1 Status Display	8-1
7.2 Status Message Definitions	8-1
8 Warnings and Alarms	9-1
8.1 System Monitoring	9-1
8.2 Warning and Alarm Types	9-1
8.3 Warning and Alarm Displays	9-1
8.4 Warning and Alarm Definitions	9-2
9 Basic Troubleshooting	10-1
9.1 Start-up and Operation	10-1
10 Specifications	11-1
10.1 Power-dependent Specifications	11-1
10.1.1 Line Power Supply 3 x 525–690 V AC	11-9
10.2 General Technical Data	11-12
10.3 Fuse Specifications	11-17
10.3.1 Branch Circuit Protection Fuses	11-17
10.3.2 UL and cUL Branch Circuit Protection Fuses	11-19
10.3.3 Substitute Fuses for 240 V	11-21
10.4 Connection Tightening Torques	11-21
12 Index	12-1

1 Introduction

1.1 Available Literature

- Instruction Manual BAS-SVX19 provides the necessary information for getting the drive up and running.
- Instruction Manual TR200 High Power BAS-SVX21
- Design Guide BAS-SVX23 contains all the technical information about the drive and customer design and applications.
- Programming Guide BAS-SVP04 provides information on how to program and includes complete parameter descriptions.

Trane technical literature is available in print from local Trane Sales Offices or online at:
www.trane.com/vfd

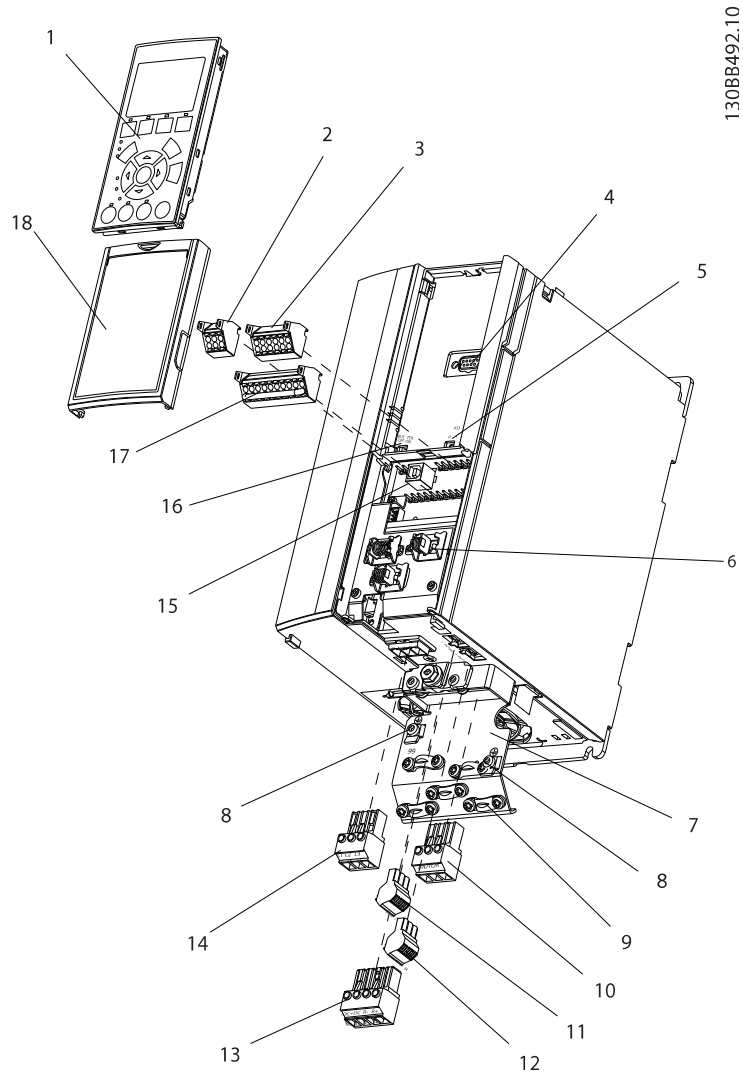

130BB492.10

Figure 1.1 Exploded View A Size

1	LCP	10	Motor output terminals 96 (U), 97 (V), 98 (W)
2	RS-485 serial bus connector (+68, -69)	11	Relay 2 (01, 02, 03)
3	Analog I/O connector	12	Relay 1 (04, 05, 06)
4	LCP input plug	13	Brake (-81, +82) and load sharing (-88, +89) terminals
5	Analog switches (A53), (A54)	14	Line power input terminals 91 (L1), 92 (L2), 93 (L3)
6	Cable strain relief/PE ground	15	USB connector
7	Decoupling plate	16	Serial bus terminal switch
8	Grounding clamp (PE)	17	Digital I/O and 24 V power supply
9	Shielded cable grounding clamp and strain relief	18	Control cable cover plate

Table 1.1 Legend to Figure 1.1

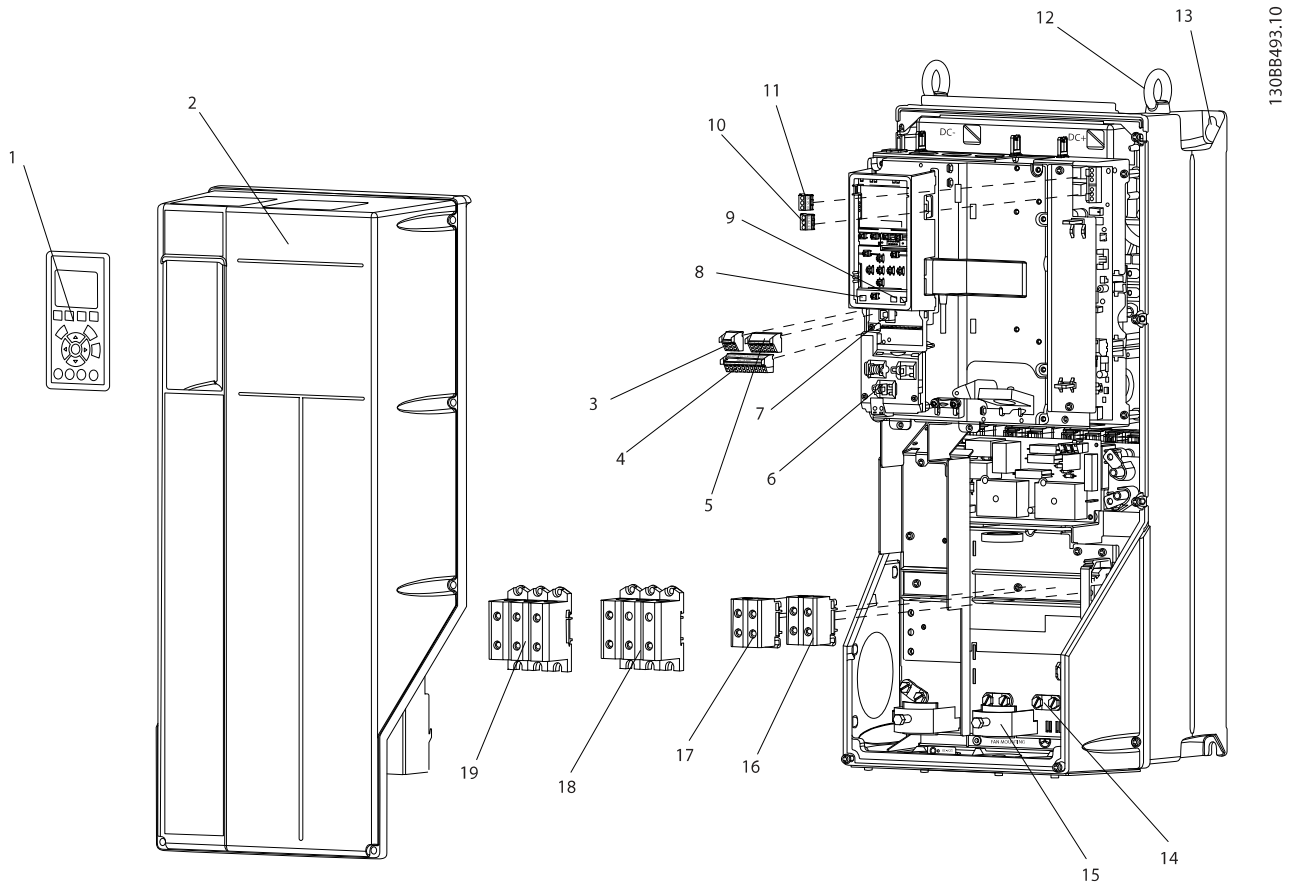

1308B493.10

Figure 1.2 Exploded View B and C Sizes

1	LCP	11	Relay 2 (04, 05, 06)
2	Cover	12	Lifting ring
3	RS-485 serial bus connector	13	Mounting slot
4	Digital I/O and 24 V power supply	14	Grounding clamp (PE)
5	Analog I/O connector	15	Cable strain relief / PE ground
6	Cable strain relief/PE ground	16	Brake terminal (-81, +82)
7	USB connector	17	Load sharing terminal (DC bus) (-88, +89)
8	Serial bus terminal switch	18	Motor output terminals 96 (U), 97 (V), 98 (W)
9	Analog switches (A53), (A54)	19	Line power input terminals 91 (L1), 92 (L2), 93 (L3)
10	Relay 1 (01, 02, 03)		

Table 1.2 Legend to Figure 1.2

1.2 Purpose of the Manual

This manual is intended to provide detailed information for the installation and start-up of the adjustable frequency drive. Chapter 2 *Installation* provides requirements for mechanical and electrical installation, including input, motor, control and serial communications wiring and control terminal functions. Chapter 3 *Start-up and Functional Testing* provides detailed procedures for start-up, basic operational programming, and functional testing. The remaining chapters provide supplementary details. These details include user interface, detailed programming, application examples, start-up troubleshooting, and specifications.

1.3 Additional Resources

Other resources are available to understand advanced adjustable frequency drive functions and programming.

- The *TR200 Programming Guide* provides greater detail on working with parameters and many application examples.
- The *TR200 Design Guide* is intended to provide detailed capabilities and functionality to design motor control systems.
- Optional equipment that may change some of the procedures described is available. Reference the instructions supplied with those options for specific requirements.

1.4 Product Overview

An adjustable frequency drive is an electronic motor controller that converts AC line power input into a variable AC waveform output. The frequency and voltage of the output are regulated to control the motor speed or torque. The adjustable frequency drive can vary the speed of the motor in response to system feedback, such as changing temperature or pressure for controlling fan, compressor, or pump motors. The adjustable frequency drive can also regulate the motor by responding to remote commands from external controllers.

In addition, the adjustable frequency drive monitors the system and motor status, issues warnings or alarms for fault conditions, starts and stops the motor, optimizes energy efficiency, and offers many more control, monitoring, and efficiency functions. Operation and monitoring functions are available as status indications to an outside control system or serial communication network.

1.5 Internal Adjustable Frequency Drive Controller Functions

Figure 1.3 is a block diagram of the adjustable frequency drive's internal components. See Table 1.3 for their functions.

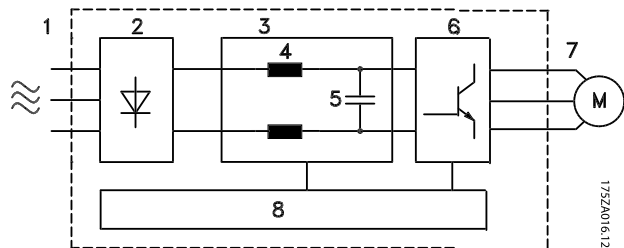

Figure 1.3 Adjustable Frequency Drive Block Diagram

Area	Title	Functions
1	Line power input	<ul style="list-style-type: none"> • Three-phase AC line power supply to the adjustable frequency drive
2	Rectifier	<ul style="list-style-type: none"> • The rectifier bridge converts the AC input to DC current to supply inverter power
3	DC bus	<ul style="list-style-type: none"> • Intermediate DC bus circuit handles the DC current
4	DC reactors	<ul style="list-style-type: none"> • Filter the intermediate DC circuit voltage • Provide line transient protection • Reduce RMS current • Raise the power factor reflected back to the line • Reduce harmonics on the AC input
5	Capacitor bank	<ul style="list-style-type: none"> • Stores the DC power • Provides ride-through protection for short power losses
6	Inverter	<ul style="list-style-type: none"> • Converts the DC into a controlled PWM AC waveform for a controlled variable output to the motor
7	Output to motor	<ul style="list-style-type: none"> • Regulated three-phase output power to the motor

Area	Title	Functions
8	Control circuitry	<ul style="list-style-type: none"> • Input power, internal processing, output, and motor current are monitored to provide efficient operation and control • User interface and external commands are monitored and performed • Status output and control can be provided

Table 1.3 Legend to Figure 1.3

1.6 Frame Sizes and Power Ratings

References to frames sizes used in this manual are defined in *Table 1.4*.

[V]	Frame size hp [kW]											
	A2	A3	A4	A5	B1	B2	B3	B4	C1	C2	C3	C4
200–240	1.5–3 [1.1–2.2]	4–5 [3.0–3.7]	1.5–3 [1.1–2.2]	1.5–5 [1.1–3.7]	7.5–15 [5.5–11]	20 [15]	7.5–15 [5.5–11]	20–25 [15–18.5]	25–40 [18.5–30]	50–60 [37–45]	30–40 [22–30]	50–60 [37–45]
380–480	1.5–5 [1.1–4.0]	7.5–10 [5.5–7.5]	1.5–5 [1.1–4.0]	1.5–10 [1.1–7.5]	15–25 [11–18.5]	30–40 [22–30]	15–25 [11–18.5]	30–50 [22–37]	50–75 [37–55]	100–125 [75–90]	60–75 [45–55]	100–125 [75–90]
525–600	n/a	1.5–10 [1.1–7.5]	n/a	1.5–10 [1.1–7.5]	15–25 [11–18.5]	30–40 [22–30]	15–25 [11–18.5]	30–50 [22–37]	50–75 [37–55]	100–125 [75–90]	60–75 [45–55]	100–125 [75–90]
525–690	n/a	1.5–10 [1.1–7.5]	n/a	n/a	n/a	15–40 [11–30]	n/a	15–50 [11–37]	n/a	50–125 [37–90]	60–75 [45–55]	n/a

Table 1.4 Frames Sizes and Power Ratings

1.7 Adjustable Frequency Drive Identification

Figure 1.4 is an example of an identification label. This label is situated on the adjustable frequency drive and shows the type and the options fitted to the unit.



130BA489.10

Figure 1.4 This example shows an identification label.

Description	Pos	Possible choice
Product group & Drive Series	1-6	TR200
Power rating	8-10	1.1-1200 kW (P1K1 - P1M2)
Number of phases	11	Three phases (T)
AC line voltage	11-12	T 2: 200–240 V AC T 4: 380–480 V AC T 6: 525–600 V AC T 7: 525–690 V AC
Enclosure	13-15	E20: IP20 E21: IP21/NEMA Type 1 E55: IP55/NEMA Type 12 E66: IP66 P21: IP21/NEMA Type 1 w/ backplate P55: IP55/NEMA Type 12 w/ backplate Z55: A4 Frame IP55 Z66: A4 Frame IP66

Description	Pos	Possible choice
RFI filter	16-17	H1: RFI filter class A1/B H2: RFI filter class A2 H3: RFI filter class A1/B (reduced cable length) Hx: No RFI filter
Brake	18	X: No brake chopper included
Display	19	G: Graphical Local Control Panel (keypad) X: No Local Control Panel
Coating PCB	20	X: No coated PCB C: Coated PCB
Line power option	21	X: No line power disconnect switch and load sharing 1: With line power disconnect switch (IP55 only) 8: Line power disconnect and Load Sharing D: Load Sharing See 10.1 Power-dependent Specifications for max. cable sizes.
Adaptation	22	X: Standard 0: European metric thread in cable entries.
Adaptation	23	Reserved
Software release	24-27	Current software
Software language	28	
A options	29-30	AX: No options A4: MCA 104 DeviceNet AF: MCA 115 LonWorks AE: MCA 116 BACnet gateway
B options	31-32	BX: No option BK: MCB 101 General purpose I/O option BP: MCB 105 Relay option
C0 options MCO	33-34	CX: No options
C1 options	35	X: No options
C option software	36-37	XX: Standard software
D options	38-39	DX: No option D0: DC backup

Table 1.5 Type Code Description

2 Installation

2.1 Installation Site Checklist

- The adjustable frequency drive relies on the ambient air for cooling. Observe the limitations on ambient air temperature for optimal operation
- Ensure that the installation location has sufficient support strength to mount the adjustable frequency drive.
- Keep the manual, drawings, and diagrams accessible for detailed installation and operation instructions. It is important that the manual is available for equipment operators.
- Locate equipment as near to the motor as possible. Keep motor cables as short as possible. Check the motor characteristics for actual tolerances. Do not exceed
 - 1000 ft [300 m] for unshielded motor leads
 - 500 ft [150 m] for shielded cable.
- Ensure that the ingress protection rating of the adjustable frequency drive is suitable for the installation environment. IP55 (NEMA 12) or IP66 (NEMA 4) enclosures may be necessary.

CAUTION

Ingress protection

IP54, IP55 and IP66 ratings can only be guaranteed if the unit is properly closed.

- Ensure that all cable connectors and unused holes for connectors are properly sealed.
- Ensure that the unit cover is properly closed

CAUTION

Device damage through contamination

Do not leave the adjustable frequency drive uncovered.

2.2 Adjustable Frequency Drive and Motor Pre-installation Checklist

- Compare the model number of unit on the nameplate to what was ordered to verify the proper equipment
- Ensure each of the following are rated for the same voltage:
 - Line power
 - Adjustable frequency drive
 - Motor
- Ensure that the adjustable frequency drive output current rating is equal to or greater than motor full load current for peak motor performance.
 - Motor size and adjustable frequency drive power must match for proper overload protection
 - If adjustable frequency drive rating is less than motor, full motor output cannot be achieved

2.3 Mechanical Installation

2.3.1 Cooling

- To provide cooling airflow, mount the unit to a solid flat surface or to the optional backplate (see *2.3.3 Mounting*)
- Top and bottom clearance for air cooling must be provided. Generally, 100–225 mm (4–10 in) is required. See *Figure 2.1* for clearance requirements
- Improper mounting can result in overheating and reduced performance.
- Derating for temperatures starting between 104 °F [40 °C] and 122 °F [50 °C] and elevation 3300 ft [1000 m] above sea level must be considered. See the equipment Design Guide for detailed information.

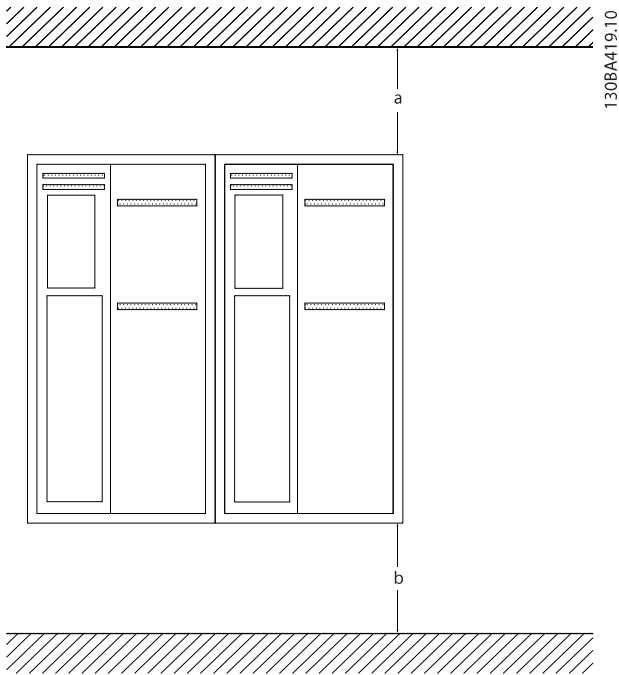

Figure 2.1 Top and Bottom Cooling Clearance

Enclosure	A2-A5	B1-B4	C1, C3	C2, C4
a/b (inch [mm])	100	200	200	225

Table 2.1 Minimum Airflow Clearance Requirements

2.3.2 Lifting

- Check the weight of the unit to determine a safe lifting method
- Ensure that the lifting device is suitable for the task
- If necessary, plan for a hoist, crane, or forklift with the appropriate rating to move the unit
- For lifting, use hoist rings on the unit, where provided

2.3.3 Mounting

- Mount the unit vertically.
- The adjustable frequency drive allows side by side installation.
- Ensure that the strength of the mounting location will support the unit weight.
- Mount the unit onto a solid flat surface or onto the optional backplate to provide cooling airflow (see Figure 2.2 and Figure 2.3).

- Improper mounting can result in overheating and reduced performance.
- Use the slotted mounting holes on the unit for wall mounting, when provided.

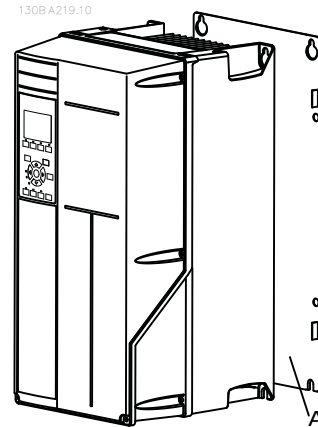

Figure 2.2 Proper Mounting with Backplate

Item A in Figure 2.2 and Figure 2.3 is a backplate properly installed for required airflow to cool the unit.

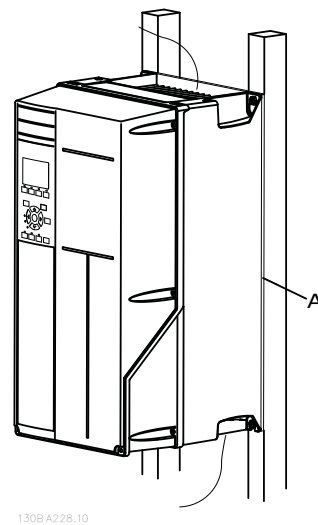

Figure 2.3 Proper Mounting with Railings

NOTE!

Backplate is needed when mounted on railings.

2.3.4 Tightening Torques

See for proper tightening specifications.

2.4 Electrical Installation

This section contains detailed instructions for wiring the adjustable frequency drive. The following tasks are described.

- Wiring the motor to the adjustable frequency drive output terminals
- Wiring the AC line power to the adjustable frequency drive input terminals
- Connecting control and serial communication wiring
- After power has been applied, checking input and motor power; programming control terminals for their intended functions

Figure 2.4 shows a basic electrical connection.

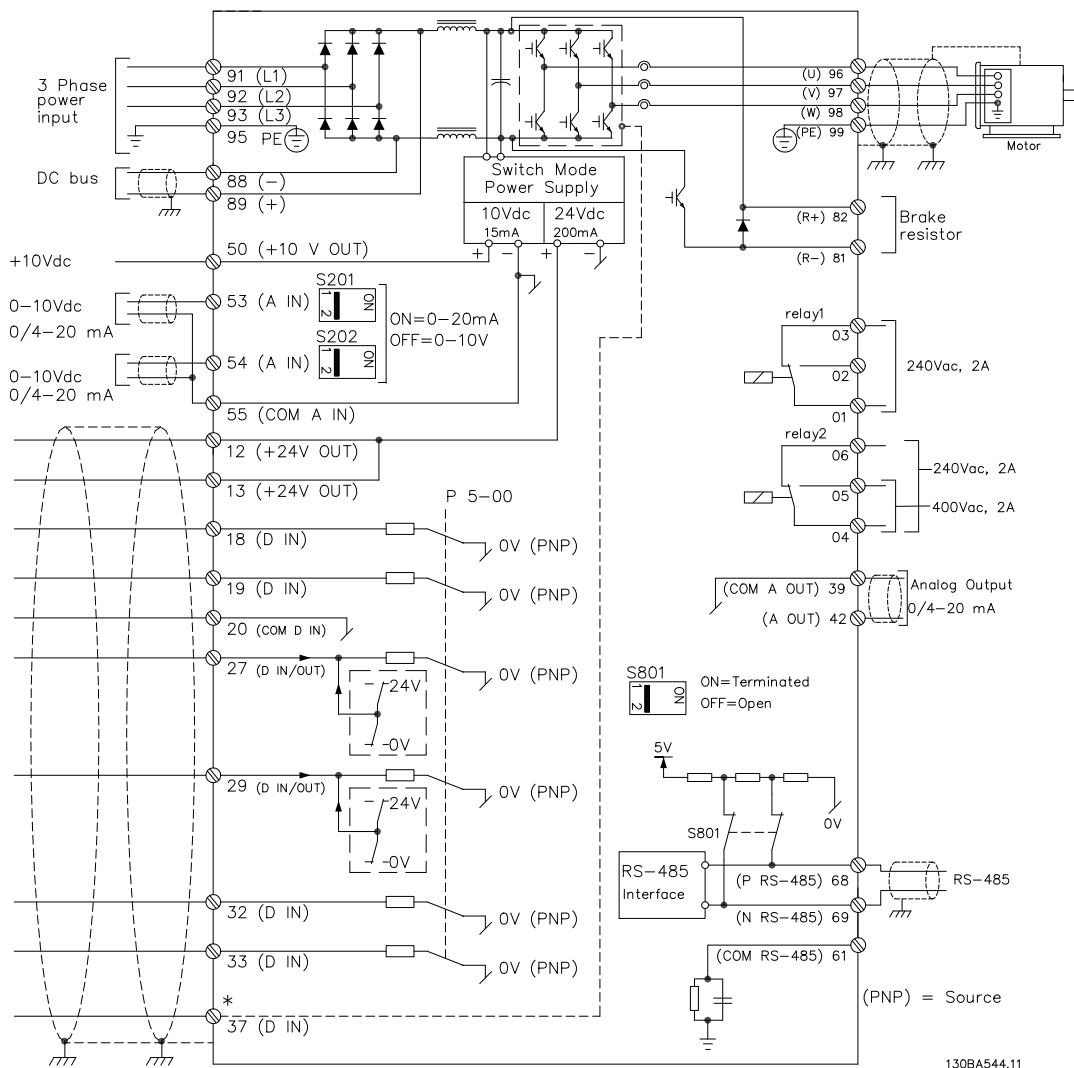

Figure 2.4 Basic Wiring Schematic Drawing

* Terminal 37 is an option

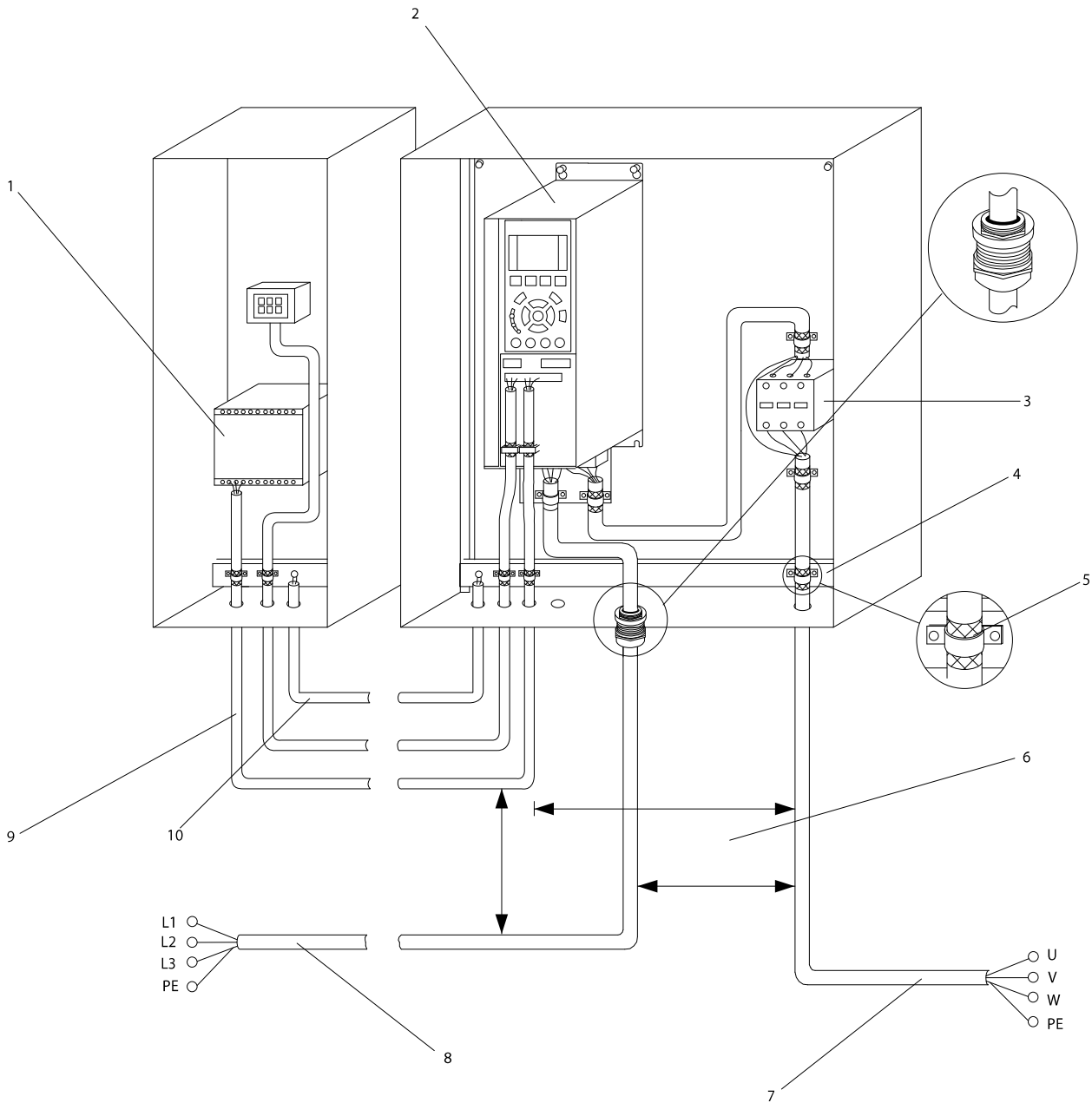

Figure 2.5 Typical Electrical Connection

1	PLC	6	Min. 7.9 in [200 mm] between control cables, motor and line power
2	Adjustable frequency drive	7	Motor, 3-phase and PE
3	Output contactor (generally not recommended)	8	Line power, 3-phase and reinforced PE
4	Grounding rail (PE)	9	Control wiring
5	Cable insulation (stripped)	10	Equalizing min. 0.025 in ² [16 mm ²]

Table 2.2 Legend to Figure 2.5

2.4.1 Requirements

⚠ WARNING

EQUIPMENT HAZARD!

Rotating shafts and electrical equipment can be hazardous. All electrical work must conform to national and local electrical codes. It is strongly recommended that installation, start-up, and maintenance be performed only by trained and qualified personnel. Failure to follow these guidelines could result in death or serious injury.

CAUTION

WIRING ISOLATION!

Run input power, motor wiring and control wiring in three separate metallic conduits or use separated shielded cable for high frequency noise isolation. Failure to isolate power, motor and control wiring could result in less than optimum adjustable frequency drive and associated equipment performance.

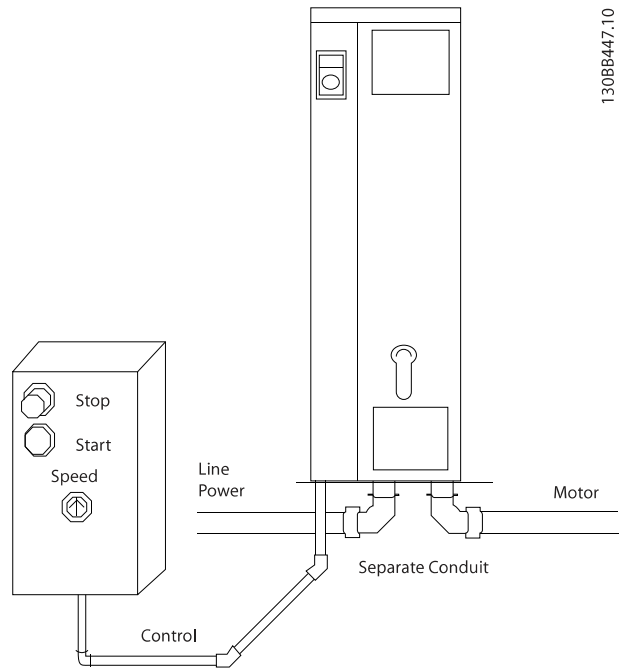

Figure 2.6 Proper Electrical Installation Using Conduit

For your safety, comply with the following requirements.

- Electronic controls equipment is connected to hazardous AC line voltage. Extreme care should be taken to protect against electrical hazards when applying power to the unit.
- Run motor cables from multiple adjustable frequency drives separately. Induced voltage from output motor cables run together can charge equipment capacitors even with the equipment turned off and locked out.

Overload and Equipment Protection

- An electronically activated function within the adjustable frequency drive provides overload protection for the motor. The overload calculates the level of increase to activate timing for the trip (controller output stop) function. The higher the current draw, the quicker the trip response. The overload provides Class 20 motor protection. See for details on the trip function.
- Because the motor wiring carries high frequency current, it is important that wiring for line power, motor power, and control is run separately. Use metallic conduit or separated shielded wire. Failure to isolate power, motor, and control wiring could result in less than optimum equipment performance. See Figure 2.6.

- All adjustable frequency drives must be provided with short-circuit and overcurrent protection. Input fusing is required to provide this protection, see Figure 2.7. If not factory supplied, fuses must be provided by the installer as part of installation. See maximum fuse ratings in .

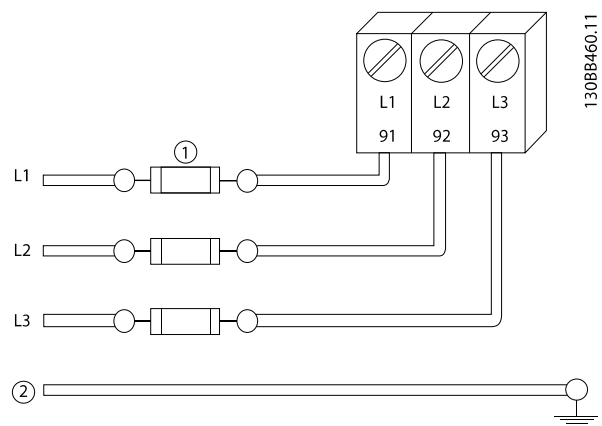

Figure 2.7 Adjustable Frequency Drive Fuses

Wire Type and Ratings

- All wiring must comply with local and national regulations regarding cross-section and ambient temperature requirements.
- Trane recommends that all power connections be made with a minimum 167 °F [75 °C] rated copper wire.
- See for recommended wire sizes.

2.4.2 Grounding Requirements

⚠ WARNING

GROUNDING HAZARD!

For operator safety, it is important to ground the adjustable frequency drive properly in accordance with national and local electrical codes as well as instructions contained within this document. Ground currents are higher than 3.5 mA. Failure to ground the adjustable frequency drive properly could result in death or serious injury.

NOTE!

It is the responsibility of the user or certified electrical installer to ensure correct grounding of the equipment in accordance with national and local electrical codes and standards.

- Follow all local and national electrical codes to ground electrical equipment properly.
- Proper protective grounding for equipment with ground currents higher than 3.5 mA must be established, see 2.4.2.1 *Leakage Current (>3.5 mA)*
- A dedicated ground wire is required for input power, motor power and control wiring
- Use the clamps provided with the equipment for proper ground connections
- Do not ground one adjustable frequency drive to another in a "daisy chain" fashion
- Keep the ground wire connections as short as possible
- Using high-strand wire to reduce electrical noise is recommended
- Follow the motor manufacturer wiring requirements

2.4.2.1 Leakage Current (>3.5 mA)

Follow national and local codes regarding protective grounding of equipment with a leakage current > 3.5 mA. Adjustable frequency drive technology implies high frequency switching at high power. This will generate a leakage current in the ground connection. A fault current in the adjustable frequency drive at the output power terminals might contain a DC component which can charge the filter capacitors and cause a transient ground current. The ground leakage current depends on various system configurations including RFI filtering, shielded motor cables, and adjustable frequency drive power.

EN/IEC61800-5-1 (Power Drive System Product Standard) requires special care if the leakage current exceeds 3.5 mA. Grounding must be reinforced in one of the following ways:

- Ground wire of at least 10 mm²
- Two separate ground wires both complying with the dimensioning rules

See EN 60364-5-54 § 543.7 for further information.

Using RCDs

Where residual current devices (RCDs), also known as ground leakage circuit breakers (GLCBs), are used, comply with the following:

Use RCDs of type B only which are capable of detecting AC and DC currents

Use RCDs with a soft-charge delay to prevent faults due to transient ground currents

Dimension RCDs according to the system configuration and environmental considerations

2.4.2.2 Grounding Using Shielded Cable

Grounding clamps are provided for motor wiring (see Figure 2.8).

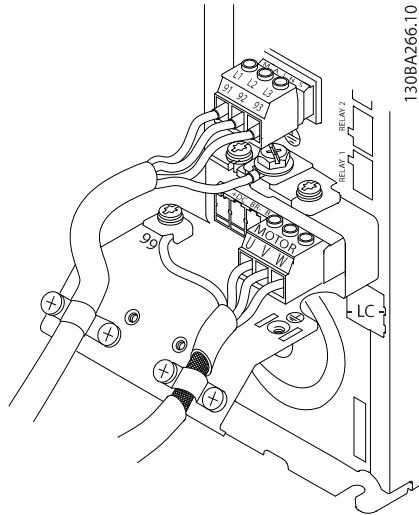

Figure 2.8 Grounding with Shielded Cable

2.4.3 Motor Connection

WARNING

INDUCED VOLTAGE!

Run output motor cables from multiple adjustable frequency drives separately. Induced voltage from output motor cables run together can charge equipment capacitors even with the equipment turned off and locked out. Failure to run output motor cables separately could result in death or serious injury.

- For maximum wire sizes, see
- Comply with local and national electrical codes for cable sizes.
- Motor wiring knockouts or access panels are provided at the base of IP21 and higher (NEMA1/12) units
- Do not install power factor correction capacitors between the adjustable frequency drive and the motor
- Do not wire a starting or pole-changing device between the adjustable frequency drive and the motor.
- Connect the 3-phase motor wiring to terminals 96 (U), 97 (V), and 98 (W).
- Ground the cable in accordance with grounding instructions provided.

- Torque terminals in accordance with the information provided in
- Follow the motor manufacturer wiring requirements

Figure 2.9, Figure 2.10 and Figure 2.11 represent line power input, motor, and grounding for basic adjustable frequency drives. Actual configurations vary with unit types and optional equipment.

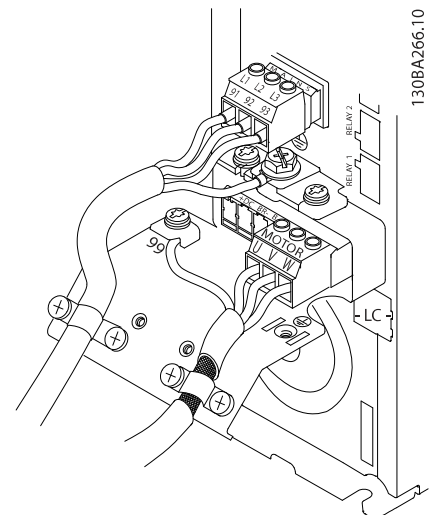

Figure 2.9 Motor, Line Power and Ground Wiring for A-Frame Sizes

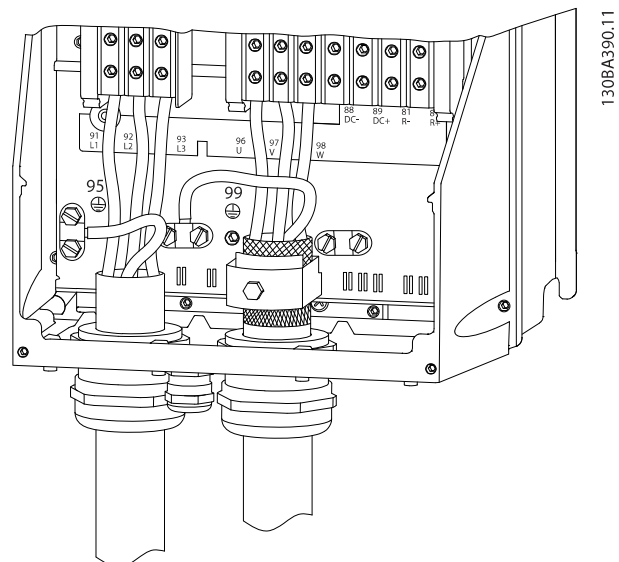
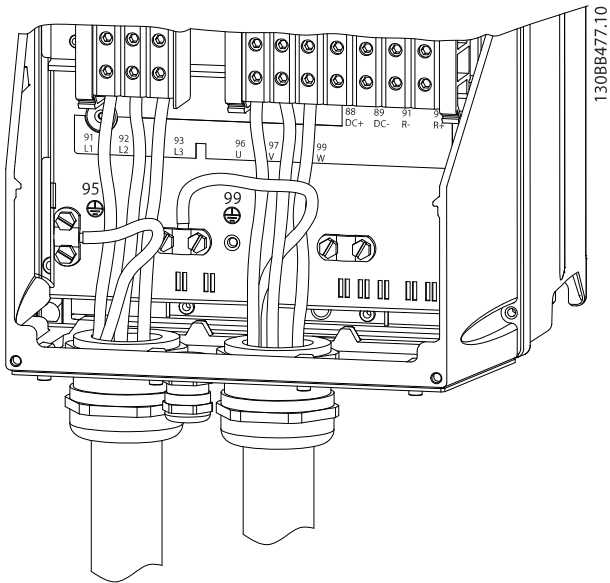

Figure 2.10 Motor, Line Power and Ground Wiring for B-, C- and D-Frame Sizes Using Shielded Cable



130BB477.10

Figure 2.11 Motor, Line Power and Ground Wiring for B-, C- and D-Frame Sizes Using Conduit

2.4.3.1 Motor Connection for A2 and A3

Follow these drawings step-by-step for connecting the motor to the adjustable frequency drive.

1. Connect the motor ground wire to terminal 99, place motor U, V and W wires in plug and tighten.

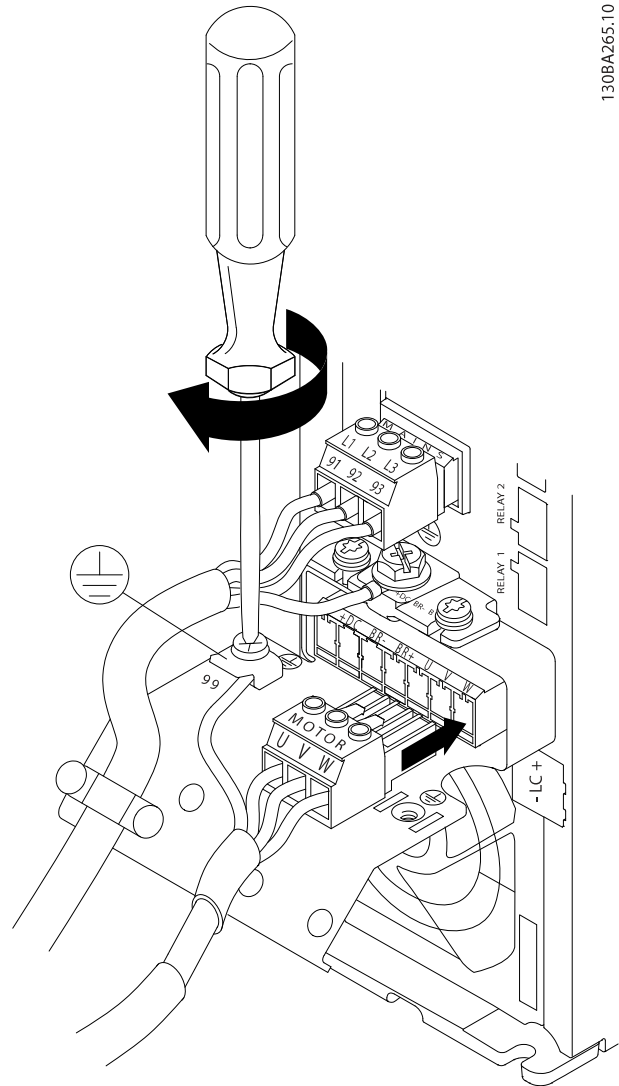

130BA265.10

Figure 2.12 Motor Connection for A2 and A3

2. Mount cable clamp to ensure 360° connection between chassis and shield, note the outer insulation of the motor cable is removed under the clamp.

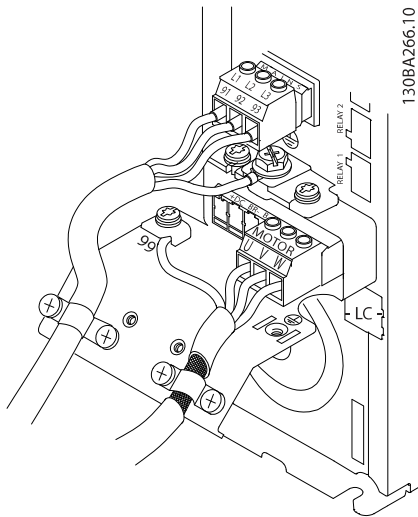

Figure 2.13 Cable Clamp Mounting

2.4.3.2 Motor Connection for A4/A5

First, terminate the motor ground, then insert the motor U, V and W wires in the terminal and tighten them. Ensure that the outer insulation of the motor cable is removed under the EMC clamp.

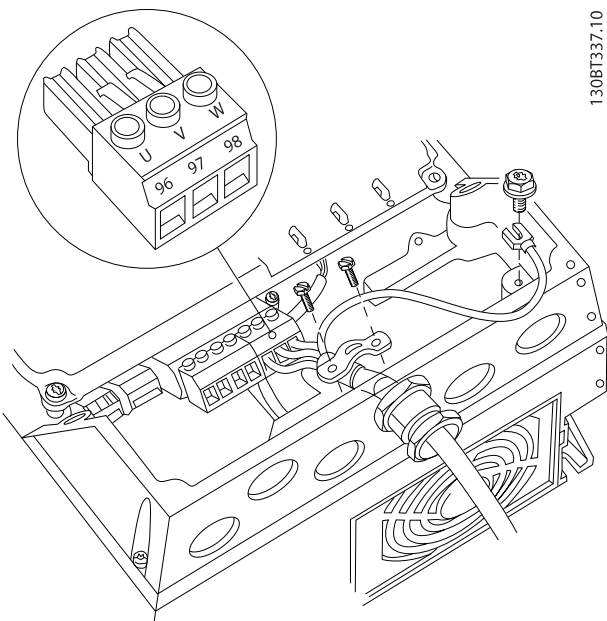

Figure 2.14 Motor Connection for A4/A5

2.4.3.3 Motor Connection for B1 and B2

First, terminate the motor ground, then insert the motor U, V and W wires in the terminal and tighten them. Ensure that the outer insulation of the motor cable is removed under the EMC clamp.

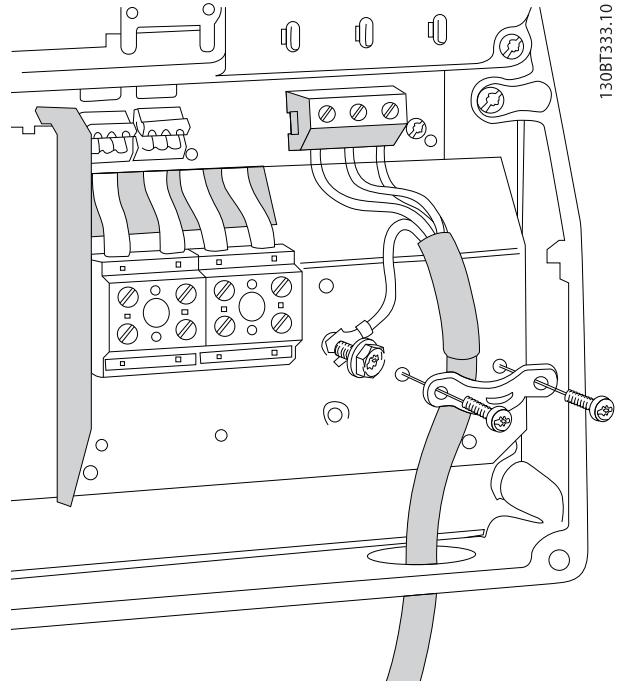

Figure 2.15 Motor Connection for B1 and B2

2.4.3.4 Motor Connection for C1 and C2

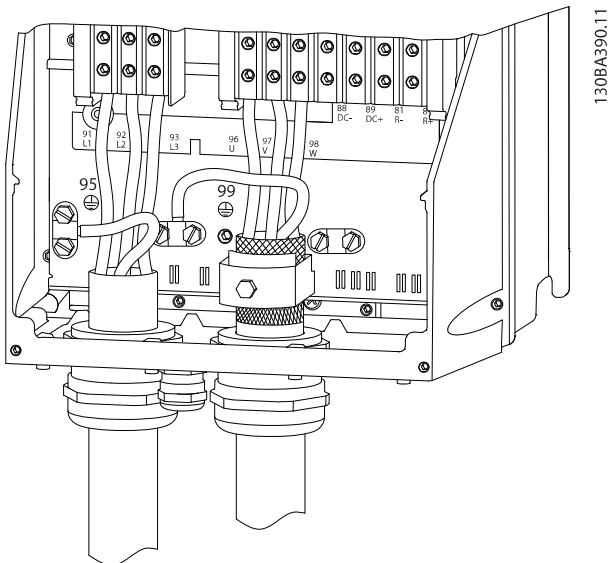

Figure 2.16 Motor Connection for C1 and C2

First terminate the motor ground, then place motor U, V and W wires in the terminal and tighten them. Ensure that the outer insulation of the motor cable is removed under the EMC clamp.

2.4.4 AC Line Input Connection

- Size wiring based upon the input current of the adjustable frequency drive. For maximum wire sizes, see 10.1 *Power-dependent Specifications*.
- Comply with local and national electrical codes for cable sizes.
- Connect 3-phase AC input power wiring to terminals L1, L2, and L3 (see Figure 2.17).
- Depending on the configuration of the equipment, input power will be connected to the line power input terminals or the input disconnect.

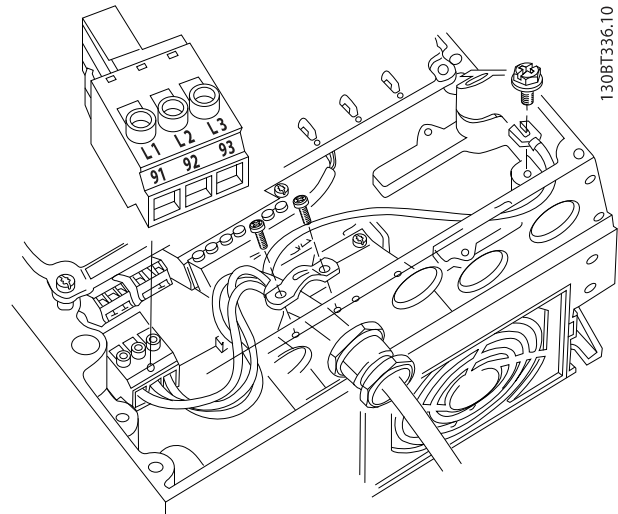

Figure 2.17 Connecting to AC Line Power

- Ground the cable in accordance with grounding instructions provided in 2.4.2 *Grounding Requirements*
- All adjustable frequency drives may be used with an isolated input source as well as with ground reference power lines. When supplied from an isolated line power source (IT line power or floating delta) or TT/TN-S line power with a grounded leg (grounded delta), set 14-50 *RFI 1* to OFF. When off, the internal RFI filter capacitors between the chassis and the intermediate circuit are isolated to avoid damage to the intermediate circuit and to reduce ground capacity currents in accordance with IEC 61800-3.

2.4.5 Control Wiring

- Isolate control wiring from high power components in the adjustable frequency drive.
- If the adjustable frequency drive is connected to a thermistor, for PELV isolation, optional thermistor control wiring must be reinforced/double insulated. A 24 V DC supply voltage is recommended.

2.4.5.1 Access

- Remove access cover plate with a screwdriver. See *Figure 2.18*.
- Or remove front cover by loosening attaching screws. See *Figure 2.19*.

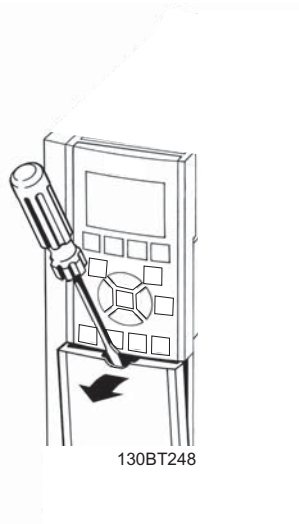

Figure 2.18 Control Wiring Access for A2, A3, B3, B4, C3 and C4 Enclosures

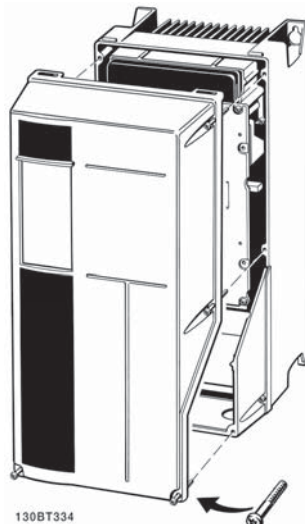

Figure 2.19 Control Wiring Access for A4, A5, B1, B2, C1 and C2 Enclosures

See *Table 2.3* before tightening the covers.

Frame	IP20	IP21	IP55	IP66
A3/A4/A5	-	-	2	2
B1/B2	-	*	2.2	2.2
C1/C2/C3/C4	-	*	2.2	2.2
* No screws to tighten - Does not exist				

Table 2.3 Tightening Torques for Covers (Nm)

2.4.5.2 Control Terminal Types

Figure 2.20 shows the removable adjustable frequency drive connectors. Terminal functions and default settings are summarized in *Table 2.4*.

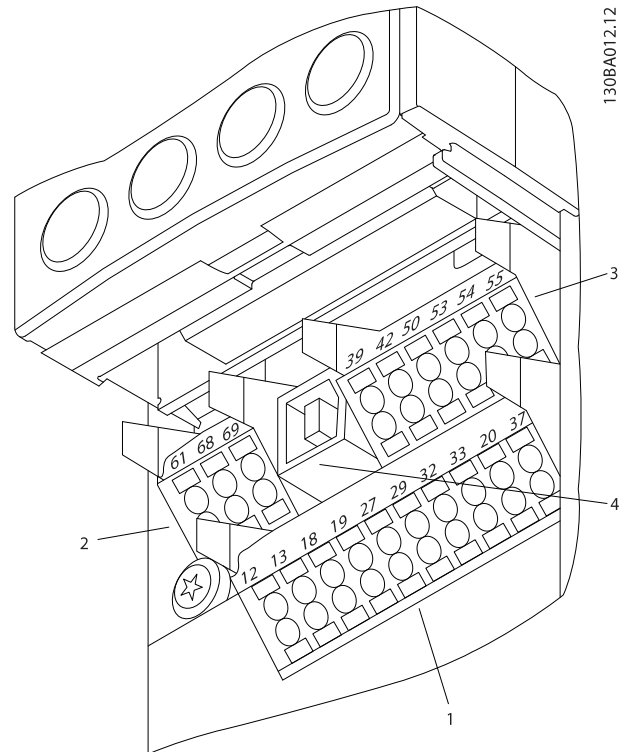

Figure 2.20 Control Terminal Locations

- **Connector 1** provides four programmable digital inputs terminals, two additional digital terminals programmable as either input or output, a 24 V DC terminal supply voltage, and a common for optional customer-supplied 24 V DC voltage
- **Connector 2** terminals (+)68 and (-)69 are for an RS-485 serial communications connection
- **Connector 3** provides two analog inputs, one analog output, 10 V DC supply voltage, and commons for the inputs and output
- **Connector 4** is a USB port available for use with the adjustable frequency drive

- Also provided are two Form C relay outputs that are in various locations depending upon the adjustable frequency drive configuration and size
- Some options available for ordering with the unit may provide additional terminals. See the manual provided with the equipment option.

See 10.2 General Technical Data for terminal ratings details.

Terminal Description			
Digital Inputs/Outputs			
Terminal	Parameter	Default Setting	Description
12, 13	-	+24 V DC	24 V DC supply voltage. Maximum output current is 200 mA total for all 24 V loads. Usable for digital inputs and external transducers.
18	5-10	[8] Start	Digital inputs.
19	5-11	[0] No operation	
32	5-14	[0] No operation	
33	5-15	[0] No operation	
27	5-12	[2] Coast inverse	Selectable for digital input and output.
29	5-13	[14] JOG	Default setting is input.
20	-		Common for digital inputs and 0 V potential for 24 V supply.
Analog Inputs/Outputs			
39	-		Common for analog output.
42	6-50	Speed 0 - High Limit	Programmable analog output. The analog signal is 0–20 mA or 4–20 mA at a maximum of 500 Ω.
50	-	+10 V DC	10 V DC analog supply voltage. 15 mA maximum commonly used for potentiometer or thermistor.
53	6-1	Reference	Analog input.
54	6-2	Feedback	Selectable for voltage or current. Switches A53 and A54 select mA or V.

Terminal Description			
Digital Inputs/Outputs			
Terminal	Parameter	Default Setting	Description
55	-		Common for analog input.
Serial Communication			
61	-		Integrated RC filter for cable shield. ONLY for connecting the shield when experiencing EMC problems.
68 (+)	8-3		RS-485 Interface. A control card switch is provided for termination resistance.
69 (-)	8-3		
Relays			
01, 02, 03	5-40 [0]	[0] Alarm	Form C relay output.
04, 05, 06	5-40 [1]	[0] Running	Usable for AC or DC voltage and resistive or inductive loads.

Table 2.4 Terminal Description

2.4.5.3 Wiring to Control Terminals

Control terminal connectors can be unplugged from the adjustable frequency drive for ease of installation, as shown in *Figure 2.21*.

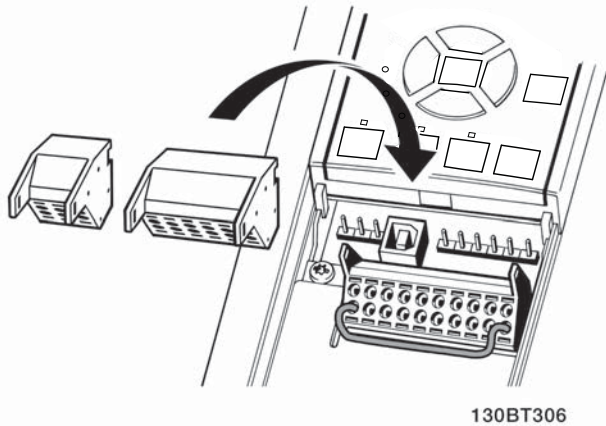

Figure 2.21 Unplugging Control Terminals

1. Open the contact by inserting a small screwdriver into the slot above or below the contact, as shown in *Figure 2.22*.
2. Insert the bared control wire into the contact.
3. Remove the screwdriver to fasten the control wire into the contact.
4. Ensure the contact is firmly established and not loose. Loose control wiring can be the source of equipment faults or less than optimal operation.

See 10.1 *Power-dependent Specifications* for control terminal wiring sizes.

See 6 *Application Set-up Examples* for typical control wiring connections.

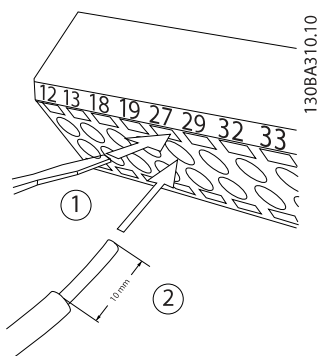

Figure 2.22 Connecting Control Wiring

2.4.5.4 Using Shielded Control Cables

Correct shielding

The preferred method in most cases is to secure control and serial communication cables with shielding clamps provided at both ends to ensure best possible high frequency cable contact.

If the ground potential between the adjustable frequency drive and the PLC is different, electrical noise may occur that will disturb the entire system. Solve this problem by fitting an equalizing cable next to the control cable.

Minimum cable cross-section: 16 mm².

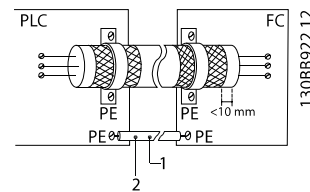

Figure 2.23 Correct Shielding

1	Min. 16 mm ²
2	Equalizing cable

Table 2.5 Legend to *Figure 2.23*

50/60 Hz ground loops

With very long control cables, ground loops may occur. To eliminate ground loops, connect one end of the shield-to-ground with a 100 nF capacitor (keeping leads short).

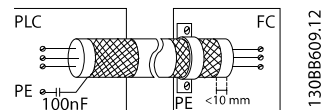

Figure 2.24 50/60 Hz Ground Loops

Avoid EMC noise on serial communication

This terminal is grounded via an internal RC link. Use twisted-pair cables to reduce interference between conductors. The recommended method is shown in *Figure 2.25*:

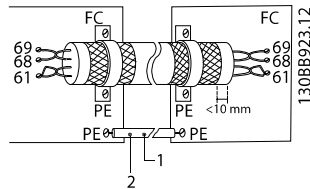

Figure 2.25 Twisted-pair Cables

1	Min. 16 mm ²
2	Equalizing cable

Table 2.6 Legend to *Figure 2.25*

Alternatively, the connection to terminal 61 can be omitted:

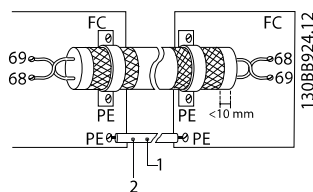

Figure 2.26 Twisted-pair Cables without Terminal 61

1	Min. 16 mm ²
2	Equalizing cable

Table 2.7 Legend to *Figure 2.26*

2.4.5.5 Control Terminal Functions

Adjustable frequency drive functions are commanded by receiving control input signals.

- Each terminal must be programmed for the function it will be supporting in the parameters associated with that terminal. See *Table 2.4* for terminals and associated parameters.
- It is important to confirm that the control terminal is programmed for the correct function. See *4 User Interface* for details on accessing parameters and *5 About Adjustable Frequency Drive Programming* for details on programming.
- The default terminal programming is intended to initiate adjustable frequency drive functioning in a typical operational mode.

2.4.5.6 Jumper Terminals 12 and 27

A jumper wire may be required between terminal 12 (or 13) and terminal 27 for the adjustable frequency drive to operate when using factory default programming values.

- Digital input terminal 27 is designed to receive a 24 V DC external interlock command. In many applications, the user wires an external interlock device to terminal 27
- When no interlock device is used, wire a jumper between control terminal 12 (recommended) or 13 to terminal 27. This provides an internal 24 V signal on terminal 27.
- No signal present prevents the unit from operating.
- When the status line at the bottom of the LCP reads AUTO REMOTE COASTING or *Alarm 60 External Interlock* is displayed, this indicates that the unit is ready to operate but is missing an input signal on terminal 27.
- When factory installed optional equipment is wired to terminal 27, do not remove that wiring.

2.4.5.7 Terminal 53 and 54 Switches

- Analog input terminals 53 and 54 can select either voltage (0 to 10 V) or current (0/4–20 mA) input signals.
- Remove power to the adjustable frequency drive before changing switch positions.
- Set switches A53 and A54 to select the signal type. U selects voltage, I selects current.
- The switches are accessible when the LCP has been removed (see *Figure 2.27*).

⚠ WARNING

Some option cards available for the unit may cover these switches and must be removed to change switch settings. Always remove power to the unit before removing option cards.

- Terminal 53 default is for a speed reference signal in open-loop set in *16-61 Terminal 53 Switch Setting*
- Terminal 54 default is for a feedback signal in closed-loop set in *16-63 Terminal 54 Switch Setting*

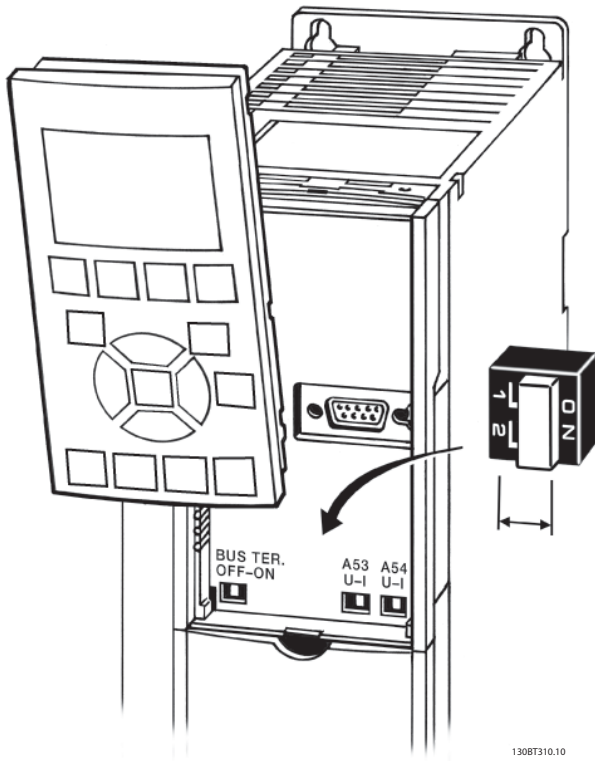

Figure 2.27 Location of Terminals 53 and 54 Switches

2.4.6 Serial Communication

RS-485 is a two-wire bus interface compatible with multi-drop network topology, i.e., nodes can be connected as a bus, or via drop cables from a common trunk line. A total of 32 nodes can be connected to one network segment. Repeaters divide network segments. Note that each repeater functions as a node within the segment in which it is installed. Each node connected within a given network must have a unique node address across all segments. Terminate each segment at both ends using either the termination switch (S801) of the adjustable frequency drives or a biased termination resistor network. Always use shielded twisted pair (STP) cable for bus cabling, and always follow good common installation practice. Low-impedance ground connection of the shield at every node is important, including at high frequencies. Thus, connect a large surface of the shield to ground, for example with a cable clamp or a conductive cable connector. It may be necessary to apply potential-equalizing cables to maintain the same ground potential throughout the network. Particularly in installations with long cables. To prevent impedance mismatch, always use the same type of cable throughout the entire network. When connecting a motor to the adjustable frequency drive, always use shielded motor cable.

Cable	Shielded twisted pair (STP)
Impedance	120 Ω
Cable length	Max. 4,000 ft [1,200 m] (including drop lines) Max. 1,650 ft [500 m] station-to-station

Table 2.8 Cable Information

3 Start-up and Functional Testing

3.1 Pre-start

3.1.1 Safety Inspection

⚠ WARNING

HIGH VOLTAGE!

If input and output connections have been connected improperly, there is potential for high voltage on these terminals. If power leads for multiple motors are improperly run in same conduit, there is potential for leakage current to charge capacitors within the adjustable frequency drive, even when disconnected from line power input. For initial start-up, make no assumptions about power components. Follow pre-start procedures. Failure to follow pre-start procedures could result in personal injury or damage to equipment.

1. Input power to the unit must be OFF and locked out. Do not rely on the adjustable frequency drive disconnect switches for input power isolation.
2. Verify that there is no voltage on input terminals L1 (91), L2 (92), and L3 (93), phase-to-phase and phase-to-ground,
3. Verify that there is no voltage on output terminals 96 (U), 97 (V), and 98 (W), phase-to-phase and phase-to-ground.
4. Confirm continuity of the motor by measuring ohm values on U-V (96-97), V-W (97-98), and W-U (98-96).
5. Check for proper grounding of the adjustable frequency drive as well as the motor.
6. Inspect the adjustable frequency drive for loose connections on terminals.
7. Record the following motor nameplate data: power, voltage, frequency, full load current, and nominal speed. These values are needed to program motor nameplate data later.
8. Confirm that the supply voltage matches voltage of adjustable frequency drive and motor.

CAUTION

Before applying power to the unit, inspect the entire installation as detailed in *Table 3.1*. Check mark those items when completed.

Inspect for	Description	<input checked="" type="checkbox"/>
Auxiliary equipment	<ul style="list-style-type: none"> Look for auxiliary equipment, switches, disconnects, or input fuses/circuit breakers that may reside on the input power side of the adjustable frequency drive or output side to the motor. Ensure that they are ready for full speed operation. Check function and installation of any sensors used for feedback to the adjustable frequency drive. Remove power factor correction caps on motor(s), if present. 	
Cable routing	<ul style="list-style-type: none"> Ensure that input power, motor wiring and control wiring are separated or in three separate metallic conduits for high frequency noise isolation. 	
Control wiring	<ul style="list-style-type: none"> Check for broken or damaged wires and loose connections. Check that control wiring is isolated from power and motor wiring for noise immunity. Check the voltage source of the signals, if necessary. The use of shielded cable or twisted pair is recommended. Ensure that the shield is terminated correctly. 	
Cooling clearance	<ul style="list-style-type: none"> Make sure that the top and bottom clearance is adequate to ensure proper airflow for cooling. 	
EMC considerations	<ul style="list-style-type: none"> Check for proper installation regarding electromagnetic compatibility. 	
Environmental considerations	<ul style="list-style-type: none"> See equipment label for the maximum ambient operating temperature limits. Humidity levels must be 5–95% non-condensing. 	
Fusing and circuit breakers	<ul style="list-style-type: none"> Check for proper fusing or circuit breakers. Check that all fuses are inserted firmly and in operational condition and that all circuit breakers are in the open position. 	
Grounding	<ul style="list-style-type: none"> The unit requires a ground wire from its chassis to the building ground. Check for good ground connections that are tight and free of oxidation. Grounding to conduit or mounting the back panel to a metal surface is not a suitable ground. 	
Input and output power wiring	<ul style="list-style-type: none"> Check for loose connections. Check that motor and line power are in separate conduit or separated shielded cables. 	
Panel interior	<ul style="list-style-type: none"> Make sure that the unit interior is free of dirt, metal chips, moisture, and corrosion. 	
Switches	<ul style="list-style-type: none"> Ensure that all switch and disconnect settings are in the proper positions. 	
Vibration	<ul style="list-style-type: none"> Check that the unit is mounted solidly or that shock mounts are used, as necessary. Check for an unusual amount of vibration. 	

Table 3.1 Start-up Check List

3.2 Applying Power

⚠ WARNING

HIGH VOLTAGE!

Adjustable frequency drives contain high voltage when connected to AC line power. Installation, start-up and maintenance should be performed by qualified personnel only. Failure to comply could result in death or serious injury.

⚠ WARNING

UNINTENDED START!

When the adjustable frequency drive is connected to AC line power, the motor may start at any time. The adjustable frequency drive, motor, and any driven equipment must be in operational readiness. Failure to comply could result in death, serious injury, equipment, or property damage.

1. Confirm that the input voltage is balanced within 3%. If not, correct input voltage imbalance before proceeding. Repeat this procedure after the voltage correction.
2. Ensure that optional equipment wiring (if present) matches the installation application.
3. Ensure that all operator devices are in the OFF position. Panel doors should be closed or cover mounted.
4. Apply power to the unit. DO NOT start the adjustable frequency drive at this time. For units with a disconnect switch, turn to the ON position to apply power to the adjustable frequency drive.

NOTE!

If the status line at the bottom of the LCP reads **AUTO REMOTE COASTING** or **Alarm 60 External Interlock** is displayed, this indicates that the unit is ready to operate but is missing an input signal on terminal 27.

3.3 Basic Operational Programming

3.3.1 Required Initial Adjustable Frequency Drive Programming

NOTE!

If the wizard is run, ignore the following.

Adjustable frequency drives require basic operational programming before running for best performance. Basic operational programming requires entering motor nameplate data for the motor being operated and the minimum and maximum motor speeds. Enter data in accordance with the following procedure. The recommended parameter settings are intended for start-up and checkout purposes. Application settings may vary. See *4 User Interface* for detailed instructions on entering data through the LCP.

Enter data with power ON, but before operating the adjustable frequency drive.

1. Press [Main Menu] twice on the LCP.
2. Use the navigation keys to scroll to parameter group **0-** Operation/Display** and press [OK].

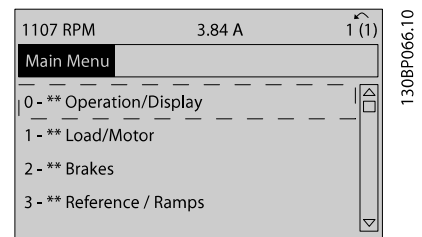

Figure 3.1 Main Menu

3. Use navigation keys to scroll to parameter group **0-0* Basic Settings** and press [OK].

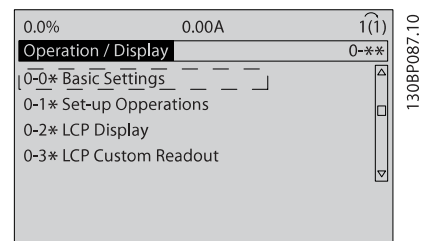

Figure 3.2 Operation/Display

- Use navigation keys to scroll to *0-03 Regional Settings* and press [OK].

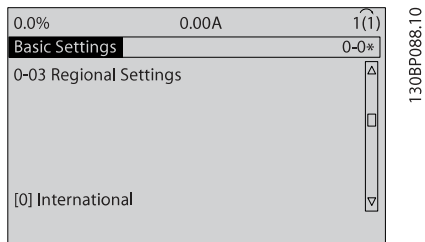

Figure 3.3 Basic Settings

- Use navigation keys to select *[0] International* or *[1] North America* as appropriate and press [OK]. (This changes the default settings for a number of basic parameters. See *5.4 International/North American Default Parameter Settings* for a complete list.)
- Press [Quick Menu] on the LCP.
- Use the navigation keys to scroll to parameter group *Q2 Quick Set-up* and press [OK].

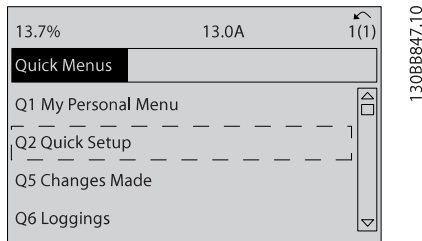

Figure 3.4 Quick Menu

- Select language and press [OK].
- A jumper wire should be in place between control terminals 12 and 27. If this is the case, leave *5-12 Terminal 27 Digital Input* at factory default. Otherwise select *No Operation*. For adjustable frequency drives with an optional Trane bypass, no jumper wire is required.
- 3-02 Minimum Reference*
- 3-03 Maximum Reference*
- 3-41 Ramp 1 Ramp-up Time*
- 3-42 Ramp 1 Ramp-down Time*
- 3-13 Reference Site*. Linked to Hand/Auto* Local Remote.

3.4 Asynchronous Motor Set-up

Enter the motor data in parameters 1-20/1-21 to 1-25. The information can be found on the motor nameplate.

- 1-20 Motor Power [kW] or 1-21 Motor Power [HP]*
 - 1-22 Motor Voltage*
 - 1-23 Motor Frequency*
 - 1-24 Motor Current*
 - 1-25 Motor Nominal Speed*

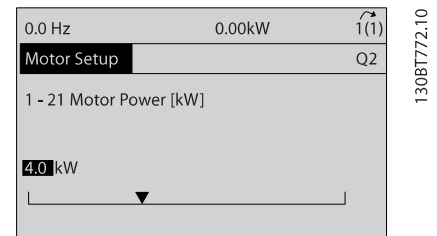

Figure 3.5 Motor Set-up

3.5 PM Motor Set-up

CAUTION

Use only a PM motor with fans and pumps.

Initial Programming Steps

- Activate PM motor operation *1-10 Motor Construction*, select *[1] PM, non-salient SPM*
- Make sure to set *0-02 Motor Speed Unit* to *[0] RPM*

Programming motor data.

After selecting PM motor in *1-10 Motor Construction*, the PM motor-related parameters in parameter groups 1-2*, 1-3* and 1-4* are active.

The information can be found on the motor nameplate and in the motor data sheet.

Following parameters must be programmed in the listed order

- 1-24 Motor Current*
- 1-26 Motor Cont. Rated Torque*
- 1-25 Motor Nominal Speed*
- 1-39 Motor Poles*
- 1-30 Stator Resistance (Rs)*

Enter line to common stator winding resistance (Rs). If only line-line data are available, divide the

line-line value by 2 to achieve the line to common (starpoint) value.

It is also possible to measure the value with an ohmmeter, which will also take the resistance of the cable into account. Divide the measured value by 2 and enter the result.

6. *1-37 d-axis Inductance (Ld)*

Enter line to common direct axis inductance of the PM motor.

If only line-line data are available, divide the line-line value by 2 to achieve the line-common (starpoint) value.

It is also possible to measure the value with an inductance meter, which will also take the inductance of the cable into account. Divide the measured value by 2 and enter the result.

7. *1-40 Back EMF at 1000 RPM*

Enter line-to-line back EMF of PM Motor at 1,000 RPM mechanical speed (RMS value). Back EMF is the voltage generated by a PM motor when no drive is connected and the shaft is turned externally. Back EMF is normally specified for nominal motor speed or for 1000 RPM measured between two lines. If the value is not available for a motor speed of 1000 RPM, calculate the correct value as follows: If back EMF is, e.g., 320 V at 1800 RPM, it can be calculated at 1000 RPM as follows: Back EMF= (Voltage / RPM)*1000 = (320/1800)*1000 = 178. This is the value that must be programmed for *1-40 Back EMF at 1000 RPM*

Test Motor Operation

1. Start the motor at low speed (100 to 200 RPM). If the motor does not turn, check installation, general programming and motor data.
2. Check if start function in *1-70 PM Start Mode* fits the application requirements.

Rotor detection

This function is the recommended choice for applications where the motor starts from standstill, e.g., pumps or conveyors. On some motors, an acoustic sound is heard when the impulse is sent out. This does not harm the motor.

Parking

This function is the recommended choice for applications where the motor is rotating at slow speed, e.g., windmilling in fan applications. *2-06 Parking Current* and *2-07 Parking Time* can be adjusted. Increase the factory setting of these parameters for applications with high inertia.

Start the motor at nominal speed. In case the application does not run well, check the VVC^{plus} PM settings. Recommendations for different applications can be seen in *Table 3.2*.

Application	Settings
Low inertia applications $I_{Load}/I_{Motor} < 5$	<i>1-17 Voltage filter time const.</i> to be increased by factor 5 to 10 <i>1-14 Damping Gain</i> should be reduced <i>1-66 Min. Current at Low Speed</i> should be reduced (<100%)
Low inertia applications $50 > I_{Load}/I_{Motor} > 5$	Keep calculated values
High inertia applications $I_{Load}/I_{Motor} > 50$	<i>1-14 Damping Gain</i> , <i>1-15 Low Speed Filter Time Const.</i> and <i>1-16 High Speed Filter Time Const.</i> should be increased
High load at low speed <30% (rated speed)	<i>1-17 Voltage filter time const.</i> should be increased <i>1-66 Min. Current at Low Speed</i> should be increased (>100% for longer time can overheat the motor)

Table 3.2 Recommendations for Different Applications

If the motor starts oscillating at a certain speed, increase *1-14 Damping Gain*. Increase the value in small steps. Depending on the motor, a good value for this parameter can be 10% or 100% higher than the default value.

Starting torque can be adjusted in *1-66 Min. Current at Low Speed*. 100% provides nominal torque as starting torque.

3.6 Automatic Motor Adaptation

Automatic motor adaptation (AMA) is a test procedure that measures the electrical characteristics of the motor to optimize compatibility between the adjustable frequency drive and the motor.

- The adjustable frequency drive builds a mathematical model of the motor for regulating output motor current. The procedure also tests the input phase balance of electrical power. It compares the motor characteristics with the data entered in parameters 1-20 to 1-25.
- The motor shaft does not turn and no harm is done to the motor while running the AMA.
- Some motors may be unable to run the complete version of the test. In that case, select [2] Enable reduced AMA.
- If an output filter is connected to the motor, select Enable reduced AMA.
- If warnings or alarms occur, see *8 Warnings and Alarms*.
- Run this procedure on a cold motor for best results.

NOTE!

The AMA algorithm does not work when using PM motors.

To run AMA

1. Press [Main Menu] to access parameters.
2. Scroll to parameter group 1-** *Load and Motor*.
3. Press [OK].
4. Scroll to parameter group 1-2* *Motor Data*.
5. Press [OK].
6. Scroll to 1-29 *Automatic Motor Adaptation (AMA)*.
7. Press [OK].
8. Select [1] *Enable complete AMA*.
9. Press [OK].
10. Follow the on-screen instructions.
11. The test will run automatically and indicate when it is complete.

3.7 Check Motor Rotation

Before running the adjustable frequency drive, check the motor rotation. The motor will run briefly at 5 Hz or the minimum frequency set in *4-12 Motor Speed Low Limit [Hz]*.

1. Press [Quick Menu].
2. Scroll to *Q2 Quick Set-up*.
3. Press [OK].
4. Scroll to *1-28 Motor Rotation Check*.
5. Press [OK].
6. Scroll to [1] *Enable*.

The following text will appear: *Note! Motor may run in wrong direction.*

7. Press [OK].
8. Follow the on-screen instructions.

To change the direction of rotation, remove power to the adjustable frequency drive and wait for power to discharge. Reverse the connection of any two of the three motor cables on the motor or adjustable frequency drive side of the connection.

3.8 Local Control Test

CAUTION

MOTOR START!

Ensure that the motor, system and any attached equipment are ready for start. It is the responsibility of the user to ensure safe operation under any condition. Failure to ensure that the motor, system, and any attached equipment is ready for start could result in personal injury or equipment damage.

NOTE!

The [Hand On] key provides a local start command to the adjustable frequency drive. The [Off] key provides the stop function.

When operating in local mode, [▲] and [▼] increase and decrease the speed output of the adjustable frequency drive. [◀] and [▶] move the display cursor in the numeric display.

1. Press [Hand On].
2. Accelerate the adjustable frequency drive by pressing [▲] to full speed. Moving the cursor left of the decimal point provides quicker input changes.
3. Note any acceleration problems.
4. Press [Off].
5. Note any deceleration problems.

If acceleration problems were encountered

- If warnings or alarms occur, see
- Check that motor data is entered correctly
- Increase the ramp-up time in *3-41 Ramp 1 Ramp-up Time*
- Increase current limit in *4-18 Current Limit*
- Increase torque limit in *4-16 Torque Limit Motor Mode*

If deceleration problems were encountered

- If warnings or alarms occur, see .
- Check that motor data is entered correctly.
- Increase the ramp-down time in *3-42 Ramp 1 Ramp-down Time*.
- Enable overvoltage control in *2-17 Over-voltage Control*.

See *4.1.1* for resetting the adjustable frequency drive after a trip.

NOTE!

to conclude the procedures for applying power to the adjustable frequency drive, basic programming, set-up and functional testing.

3.9 System Start-up

The procedure in this section requires user-wiring and application programming to be completed. *6 Application Set-up Examples* is intended to help with this task. Other aids to application set-up are listed in *1.3 Additional Resources*. The following procedure is recommended after application set-up by the user is completed.

CAUTION

MOTOR START!

Ensure that the motor, system and any attached equipment is ready for start. It is the responsibility of the user to ensure safe operation under any condition. Failure to do so could result in personal injury or equipment damage.

1. Press [Auto On].
2. Ensure that external control functions are properly wired to the adjustable frequency drive and all programming completed.
3. Apply an external run command.
4. Adjust the speed reference throughout the speed range.
5. Remove the external run command.
6. Note any problems.

If warnings or alarms occur, see *8 Warnings and Alarms*.

3.10 Acoustic Noise or Vibration

If the motor or the equipment driven by the motor, e.g., a fan blade, is making noise or vibrations at certain frequencies, try the following:

- Speed Bypass, parameter group 4-6*
- Overmodulation, *14-03 Overmodulation* set to off
- Switching pattern and switching frequency parameter group 14-0*
- Resonance Dampening, *1-64 Resonance Dampening*

4 User Interface

4.1 Keypad

The local control panel (LCP) is the combined display and keypad on the front of the unit. The LCP is the user interface to the adjustable frequency drive.

The LCP has several user functions.

- Start, stop, and control speed when in local control
- Display operational data, status, warnings and cautions
- Programming adjustable frequency drive functions
- Manually reset the adjustable frequency drive after a fault when auto-reset is inactive

An optional numeric LCP (NLCP) is also available. The NLCP operates in a manner similar to the LCP. See the Programming Guide for details on use of the NLCP.

NOTE!

The display contrast can be adjusted by pressing [Status] and [▲]/[▼] keys.

4.1.1 LCP Layout

The LCP is divided into four functional groups (see Figure 4.1).

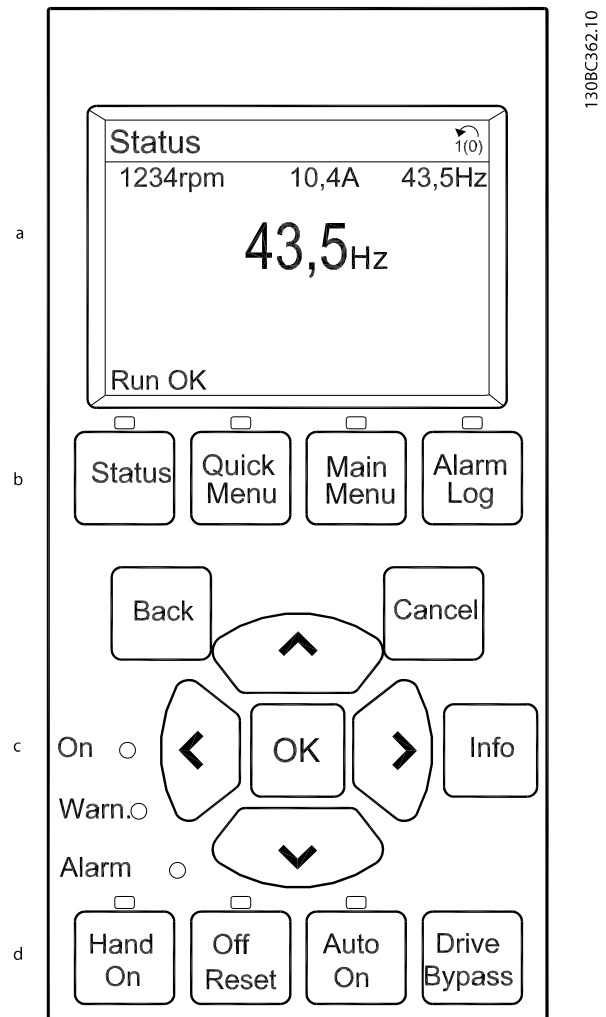

Figure 4.1 LCP

- Display area.
- Display menu keys for changing the display to show status options, programming, or error message history.
- Navigation keys for programming functions, moving the display cursor, and speed control in local operation. Also included are the status indicator lights.
- Operational mode keys and reset.

4.1.2 Setting LCP Display Values

The display area is activated when the adjustable frequency drive receives power from AC line voltage, a DC bus terminal, or an external 24 V DC supply.

The information displayed on the LCP can be customized for user application.

- Each display readout has a parameter associated with it
- Options are selected in the quick menu Q3-13 *Display Settings*
- Display 2 has an alternate larger display option
- The adjustable frequency drive status at the bottom line of the display is generated automatically and is not selectable

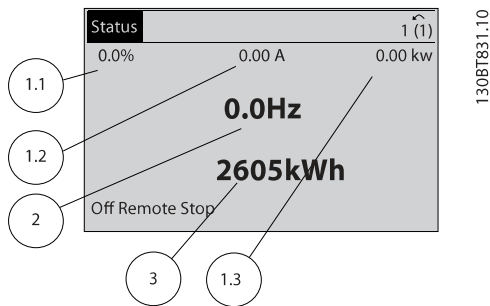

Figure 4.2 Display Readouts

Display	Parameter number	Default setting
1.1	0-20	Reference %
1.2	0-21	Motor current
1.3	0-22	Power [kW]
2	0-23	Frequency
3	0-24	kWh counter

Table 4.1 Legend to Figure 4.2

4.1.3 Display Menu Keys

Menu keys are used for menu access for parameter set-up, toggling through status display modes during normal operation, and viewing fault log data.



Figure 4.3 Menu Keys

Key	Function
Status	Shows operational information. <ul style="list-style-type: none"> • In Auto mode, press to toggle between status readout displays. • Press repeatedly to scroll through each status display. • Press [Status] plus [▲] or [▼] to adjust the display brightness. • The symbol in the upper right corner of the display shows the direction of motor rotation and which set-up is active. This is not programmable.
Quick Menu	Allows access to programming parameters for initial set-up instructions and many detailed application instructions. <ul style="list-style-type: none"> • Press to access Q2 <i>Quick Setup</i> for sequenced instructions to program the basic adjustable frequency drive set-up • Follow the sequence of parameters as presented for the function set-up
Main Menu	Allows access to all programming parameters. <ul style="list-style-type: none"> • Press twice to access top-level index • Press once to return to the last location accessed • Press to enter a parameter number for direct access to that parameter

Key	Function
Alarm Log	Displays a list of current warnings, the last ten alarms, and the maintenance log. <ul style="list-style-type: none"> For details about the adjustable frequency drive before it entered the alarm mode, select the alarm number using the navigation keys and press [OK].

Table 4.2 Function Description Menu Keys

4.1.4 Navigation Keys

Navigation keys are used for programming functions and moving the display cursor. The navigation keys also provide speed control in local (hand) operation. Three adjustable frequency drive status indicators are also located in this area.

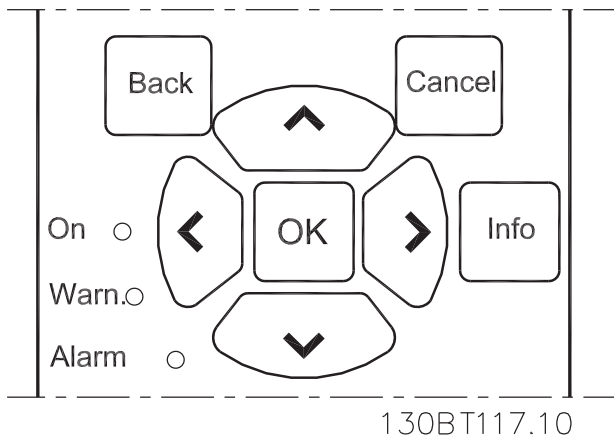

Figure 4.4 Navigation Keys

Key	Function
Back	Reverts to the previous step or list in the menu structure.
Cancel	Cancels the last change or command as long as the display mode has not changed.
Info	Press for a definition of the function being displayed.
Navigation Keys	Use the four navigation keys to move between items in the menu.
OK	Use to access parameter groups or to enable a choice.

Table 4.3 Navigation Keys Functions

Light	Indicator	Function
Green	ON	The ON light activates when the adjustable frequency drive receives power from AC line voltage, a DC bus terminal, or an external 24 V supply.
Yellow	WARNING	When warning conditions are met, the yellow WARNING light comes on and text appears in the display area identifying the problem.
Red	ALARM	A fault condition causes the red alarm light to flash and an alarm text is displayed.

Table 4.4 Indicator Lights Functions

4.1.5 Operation Keys

Operation keys are found at the bottom of the LCP.



Figure 4.5 Operation Keys

Key	Function
Hand On	Starts the adjustable frequency drive in local control. <ul style="list-style-type: none"> Use the navigation keys to control adjustable frequency drive speed. An external stop signal by control input or serial communication overrides the local hand on
Off	Stops the motor but does not remove power to the adjustable frequency drive.
Auto On	Puts the system in remote operational mode. <ul style="list-style-type: none"> Responds to an external start command by control terminals or serial communication Speed reference is from an external source
Reset	Resets the adjustable frequency drive manually after a fault has been cleared.

Table 4.5 Operation Keys Functions

4.2 Back-up and Copying Parameter Settings

Programming data is stored internally in the adjustable frequency drive.

- The data can be uploaded into the LCP memory as a storage backup.
- Once stored in the LCP, the data can be downloaded back into the adjustable frequency drive.
- Data can also be downloaded into other adjustable frequency drives by connecting the LCP into those units and downloading the stored settings. (This is a quick way to program multiple units with the same settings).
- Initialization of the adjustable frequency drive to restore factory default settings does not change data stored in the LCP memory.

⚠ WARNING

UNINTENDED START!

When the adjustable frequency drive is connected to AC line power, the motor may start at any time. The adjustable frequency drive, motor, and any driven equipment must be in operational readiness. Failure to be in operational readiness when the adjustable frequency drive is connected to AC line power could result in death, serious injury, or equipment or property damage.

4.2.1 Uploading Data to the LCP

1. Press [Off] to stop the motor before uploading or downloading data.
2. Go to *0-50 LCP Copy*.
3. Press [OK].
4. Select *All to LCP*.
5. Press [OK]. A progress bar shows the uploading process.
6. Press [Hand On] or [Auto On] to return to normal operation.

4.2.2 Downloading Data from the LCP

1. Press [Off] to stop the motor before uploading or downloading data.
2. Go to *0-50 LCP Copy*.
3. Press [OK].
4. Select *All from LCP*.
5. Press [OK]. A progress bar shows the downloading process.
6. Press [Hand On] or [Auto On] to return to normal operation.

4.3 Restoring Default Settings

CAUTION

Initialization restores the unit to factory default settings. Any programming, motor data, localization, and monitoring records will be lost. Uploading data to the LCP provides a backup before initialization.

Restoring the adjustable frequency drive parameter settings back to default values is done by initialization of the adjustable frequency drive. Initialization can be carried out through *14-22 Operation Mode* or manually.

- Initialization using *14-22 Operation Mode* does not change adjustable frequency drive data such as operating hours, serial communication selections, personal menu settings, fault log, alarm log, and other monitoring functions
- Using *14-22 Operation Mode* is generally recommended.
- Manual initialization erases all motor, programming, localization, and monitoring data and restores factory default settings.

4.3.1 Recommended Initialization

1. Press [Main Menu] twice to access parameters.
2. Scroll to *14-22 Operation Mode*.
3. Press [OK].
4. Scroll to *Initialization*.
5. Press [OK].
6. Remove power to the unit and wait for the display to turn off.
7. Apply power to the unit.

Default parameter settings are restored during start-up. This may take slightly longer than normal.

8. Alarm 80 is displayed.
9. Press [Reset] to return to operation mode.

4.3.2 Manual Initialization

1. Remove power to the unit and wait for the display to turn off.
2. Press and hold [Status], [Main Menu], and [OK] at the same time and apply power to the unit.

Factory default parameter settings are restored during start-up. This may take slightly longer than normal.

Manual initialization does not reset the following adjustable frequency drive information

- *15-00 Operating hours*
- *15-03 Power-ups*
- *15-04 Over Temps*
- *15-05 Over Volts*

5 About Adjustable Frequency Drive Programming

5.1 Introduction

The adjustable frequency drive is programmed for its application functions using parameters. Parameters are accessed by pressing either [Quick Menu] or [Main Menu] on the LCP. (See 4 *User Interface* for details on using the LCP function keys.) Parameters may also be accessed through a PC using the Trane Drive Utility (TDU) (see 5.7 *Remote Programming with Trane Drive Utility (TDU)*).

The Quick Menu is intended for initial start-up (Q2-** *Quick Set-up*) and detailed instructions for common adjustable frequency drive applications (Q3-** *Function Set-up*). Step-by-step instructions are provided. These instructions enable the user to walk through the parameters used for programming applications in their proper sequence. Data entered in a parameter can change the options available in the parameters following that entry. The quick menu presents easy guidelines for getting most systems up and running.

The main menu accesses all parameters and allows for advanced adjustable frequency drive applications.

5.2 Programming Example

Here is an example for programming the adjustable frequency drive for a common application in open-loop using the quick menu.

- This procedure programs the adjustable frequency drive to receive a 0–10 V DC analog control signal on input terminal 53
- The adjustable frequency drive will respond by providing 6–60 Hz output to the motor proportional to the input signal (0–10 V DC = 6–60 Hz)

Select the following parameters using the navigation keys to scroll to the titles and press [OK] after each action.

1. 3-15 *Reference 1 Source*

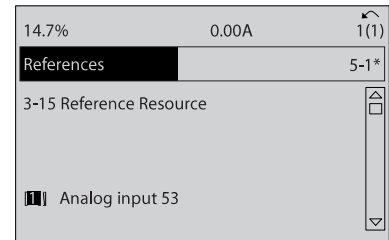

130B8848.10

Figure 5.1 References 3-15 *Reference 1 Source*

2. 3-02 *Minimum Reference*. Set minimum internal adjustable frequency drive reference to 0 Hz. (This sets the minimum adjustable frequency drive speed at 0 Hz.)

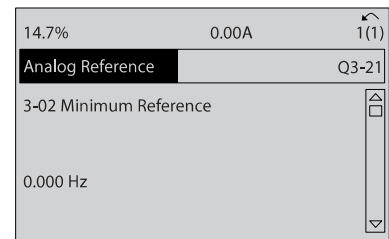

130B762.10

Figure 5.2 Analog Reference 3-02 *Minimum Reference*

3. 3-03 *Maximum Reference*. Set maximum internal adjustable frequency drive reference to 60 Hz. (This sets the maximum adjustable frequency drive speed at 60 Hz. Note that 50/60 Hz is a regional variation.)

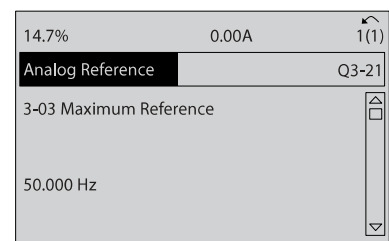

130B763.11

Figure 5.3 Analog Reference 3-03 *Maximum Reference*

4. **6-10 Terminal 53 Low Voltage.** Set minimum external voltage reference on Terminal 53 at 0 V. (This sets the minimum input signal at 0 V.)

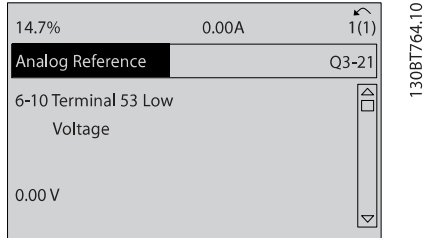

Figure 5.4 Analog Reference 6-10 Terminal 53 Low Voltage

5. **6-11 Terminal 53 High Voltage.** Set maximum external voltage reference on Terminal 53 at 10 V. (This sets the maximum input signal at 10 V.)

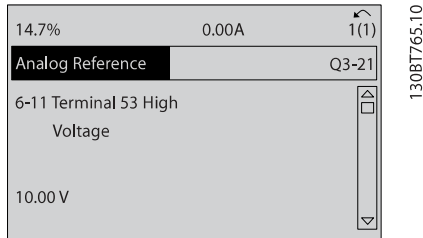

Figure 5.5 Analog Reference 6-11 Terminal 53 High Voltage

6. **6-14 Terminal 53 Low Ref./Feedb. Value.** Set minimum speed reference on Terminal 53 at 6 Hz. (This tells the adjustable frequency drive that the minimum voltage received on Terminal 53 (0 V) equals 6 Hz output.)

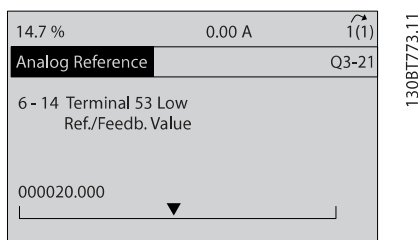

Figure 5.6 Analog Reference 6-14 Terminal 53 Low Ref./Feedb. Value

7. **6-15 Terminal 53 High Ref./Feedb. Value.** Set maximum speed reference on Terminal 53 at 60 Hz. (This tells the adjustable frequency drive that the maximum voltage received on Terminal 53 (10 V) equals 60 Hz output.)

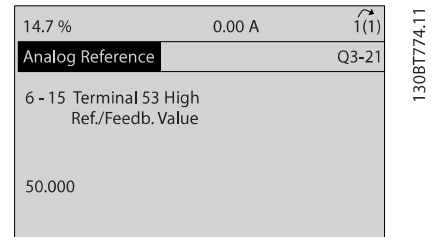

Figure 5.7 Analog Reference 6-15 Terminal 53 High Ref./Feedb. Value

With an external device providing a 0–10 V control signal connected to adjustable frequency drive terminal 53, the system is now ready for operation. Note that the scrollbar on the right in the last figure of the display is at the bottom, indicating the procedure is complete.

Figure 5.8 shows the wiring connections used to enable this set-up.

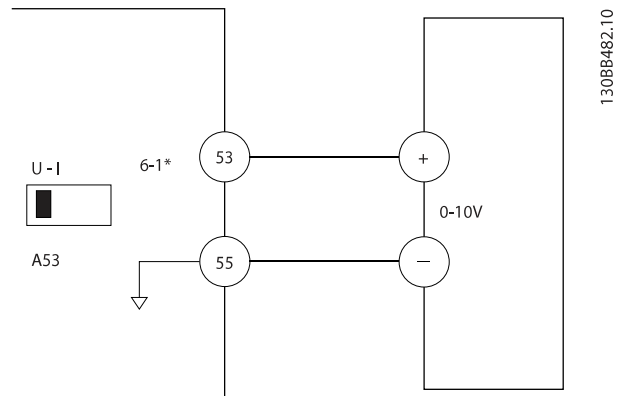

Figure 5.8 Wiring Example for External Device Providing 0–10 V Control Signal (Adjustable Frequency Drive Left, External Device Right)

5.3 Control Terminal Programming Examples

Control terminals can be programmed.

- Each terminal has specified functions it is capable of performing.
- Parameters associated with the terminal enable the function.

See *Table 2.4* for control terminal parameter number and default setting. (Default setting can change based on the selection in *0-03 Regional Settings*.)

The following example shows accessing Terminal 18 to see the default setting.

1. Press [Main Menu] twice, scroll to parameter group 5-** Digital In/Out and press [OK].

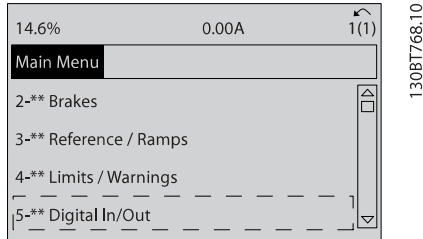

Figure 5.9 6-15 Terminal 53 High Ref./Feedb. Value

2. Scroll to parameter group 5-1* Digital Inputs and press [OK].

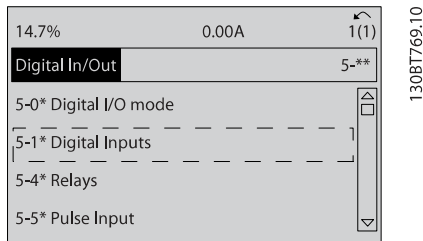

Figure 5.10 Digital In/Out

3. Scroll to 5-10 Terminal 18 Digital Input. Press [OK] to access function choices. The default setting Start is shown.

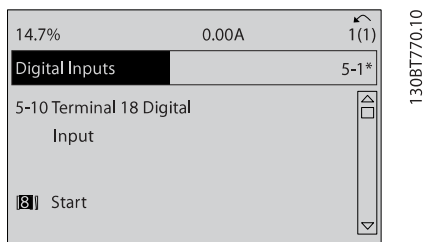

Figure 5.11 Digital Inputs

5.4 International/North American Default Parameter Settings

Setting 0-03 Regional Settings to [0] International or [1] North America changes the default settings for some parameters. Table 5.1 lists those parameters that are effected.

Parameter	International default parameter value	North American default parameter value
0-03 Regional Settings	International	North America
1-20 Motor Power [kW]	See Note 1	See Note 1
1-21 Motor Power [HP]	See Note 2	See Note 2
1-22 Motor Voltage	230 V/400 V/575 V	208 V/460 V/575 V
1-23 Motor Frequency	50 Hz	60 Hz
3-03 Maximum Reference	50 Hz	60 Hz
3-04 Reference Function	Sum	External/Preset
4-13 Motor Speed High Limit [RPM] See Note 3 and 5	1500 PM	1800 RPM
4-14 Motor Speed High Limit [Hz] See Note 4	50 Hz	60 Hz
4-19 Max Output Frequency	100 Hz	120 Hz
4-53 Warning Speed High	1500 RPM	1800 RPM
5-12 Terminal 27 Digital Input	Coast inverse	External interlock
5-40 Function Relay	Alarm	No alarm
6-15 Terminal 53 High Ref./Feedb. Value	50	60
6-50 Terminal 42 Output	Speed 0-HighLim	Speed 4-20 mA
14-20 Reset Mode	Manual reset	Infinite auto reset

Table 5.1 International/North American Default Parameter Settings

Note 1: 1-20 Motor Power [kW] is only visible when 0-03 Regional Settings is set to [0] International.

Note 2: 1-21 Motor Power [HP], is only visible when 0-03 Regional Settings is set to [1] North America.

Note 3: This parameter is only visible when 0-02 Motor Speed Unit is set to [0] RPM.

Note 4: This parameter is only visible when 0-02 Motor Speed Unit is set to [1] Hz.

Note 5: The default value depends on the number of motor poles. For a 4-poled motor, the international default value is 1500 RPM, and for a 2-poled motor, 3000 RPM. The corresponding values for North America is 1800 and 3600 RPM, respectively.

Changes made to default settings are stored and available for viewing in the quick menu along with any programming entered into parameters.

1. Press [Quick Menu].
2. Scroll to Q5 Changes Made and press [OK].
3. Select Q5-2 *Since Factory Setting* to view all programming changes or Q5-1 *Last 10 Changes* for the most recent.

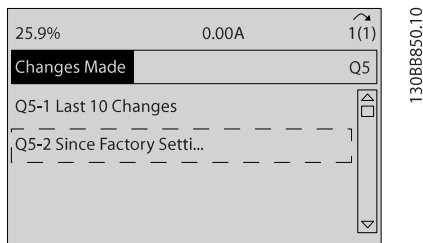

Figure 5.12 Changes Made

5.5 Parameter Menu Structure

Establishing the correct programming for applications often requires setting functions in several related parameters. These parameter settings provide the adjustable frequency drive with system details it needs to operate properly. System details may include such things as input and output signal types, programming terminals, minimum and maximum signal ranges, custom displays, automatic restart, and other features.

- See the LCP display to view detailed parameter programming and setting options.
- Press [Info] in any menu location to view additional details for that function.
- Press and hold [Main Menu] to enter a parameter number for direct access to that parameter.
- Details for common application set-ups are provided in 6 *Application Set-up Examples*.

5.4.1 Parameter Data Check

1. Press [Quick Menu].
2. Scroll to Q5 Changes Made and press [OK].

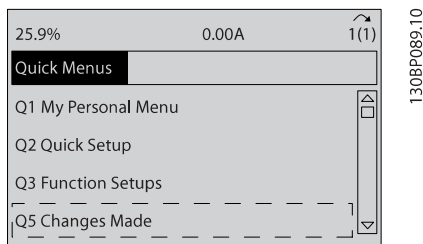

Figure 5.13 Q5 Changes Made

3. Select Q5-2 *Since Factory Setting* to view all programming changes or Q5-1 *Last 10 Changes* for the most recent.

5.5.1 Quick Menu Structure

Q3-1 General Settings	0-24 Display Line 3 Large	1-00 Configuration Mode	Q3-31 Single Zone Ext. Setpoint	20-70 Closed-loop Type
Q3-10 Adv. Motor Settings	0-37 Display Text 1	20-12 Reference/Feedback Unit	1-00 Configuration Mode	20-71 Tuning Mode
1-90 Motor Thermal Protection	0-38 Display Text 2	20-13 Minimum Reference/Feedb.	20-12 Reference/Feedback Unit	20-72 PID Output Change
1-93 Thermistor Source	0-39 Display Text 3	20-14 Maximum Reference/Feedb.	20-13 Minimum Reference/Feedb.	20-73 Minimum Feedback Level
1-29 Automatic Motor Adaptation (AMA)	Q3-2 Open-loop Settings	6-22 Terminal 54 Low Current	20-14 Maximum Reference/Feedb.	20-74 Maximum Feedback Level
14-01 Switching Frequency	Q3-20 Digital Reference	6-24 Terminal 54 Low Ref./Feedb. Value	6-10 Terminal 53 Low Voltage	20-79 PID Auto Tuning
4-53 Warning Speed High	3-02 Minimum Reference	6-25 Terminal 54 High Ref./Feedb. Value	6-11 Terminal 53 High Voltage	Q3-32 Multi Zone / Adv
Q3-11 Analog Output	3-03 Maximum Reference	6-26 Terminal 54 Filter Time	6-12 Terminal 53 Low Current	1-00 Configuration Mode
6-50 Terminal 42 Output	3-10 Preset Reference	Constant	6-13 Terminal 53 High Current	3-15 Reference 1 Source
6-51 Terminal 42 Output Min Scale	5-13 Terminal 29 Digital Input	6-00 Live Zero Timeout Time	6-14 Terminal 53 Low Ref./Feedb. Value	3-16 Reference 2 Source
6-52 Terminal 42 Output Max Scale	5-14 Terminal 32 Digital Input	6-01 Live Zero Timeout Function	6-15 Terminal 53 High Ref./Feedb. Value	20-00 Feedback 1 Source
Q3-12 Clock Settings	5-15 Terminal 33 Digital Input	20-21 Setpoint 1	6-22 Terminal 54 Low Current	20-01 Feedback 1 Conversion
0-70 Date and Time	Q3-21 Analog Reference	20-81 PID Normal/ Inverse Control	6-24 Terminal 54 Low Ref./Feedb. Value	20-02 Feedback 1 Source Unit
0-71 Date Format	3-02 Minimum Reference	20-82 PID Start Speed [RPM]	6-25 Terminal 54 High Ref./Feedb. Value	20-03 Feedback 2 Source
0-72 Time Format	3-03 Maximum Reference	20-83 PID Start Speed [Hz]	6-26 Terminal 54 Filter Time	20-04 Feedback 2 Conversion
0-74 DST/Summertime	6-10 Terminal 53 Low Voltage	20-93 PID Proportional Gain	Constant	20-05 Feedback 2 Source Unit
0-76 DST/Summertime Start	6-11 Terminal 53 High Voltage	20-94 PID Integral Time	6-27 Terminal 54 Live Zero	20-06 Feedback 3 Source
0-77 DST/Summertime End	6-12 Terminal 53 Low Current	20-70 Closed-loop Type	6-00 Live Zero Timeout Time	20-07 Feedback 3 Conversion
Q3-13 Display Settings	6-13 Terminal 53 High Current	20-71 Tuning Mode	6-01 Live Zero Timeout Function	20-08 Feedback 3 Source Unit
0-20 Display Line 1.1 Small	6-14 Terminal 53 Low Ref./Feedb. Value	20-72 PID Output Change	20-81 PID Normal/ Inverse Control	20-12 Reference/Feedback Unit
0-21 Display Line 1.2 Small	6-15 Terminal 53 High Ref./Feedb. Value	20-73 Minimum Feedback Level	20-82 PID Start Speed [RPM]	20-13 Minimum Reference/Feedb.
0-22 Display Line 1.3 Small	Q3-3 Closed-loop Settings	20-74 Maximum Feedback Level	20-83 PID Start Speed [Hz]	20-14 Maximum Reference/Feedb.
0-23 Display Line 2 Large	Q3-30 Single Zone Int. Setpoint	20-79 PID Auto Tuning	20-93 PID Proportional Gain	6-10 Terminal 53 Low Voltage

Table 5.2 Quick Menu Structure

6-11 Terminal 53 High Voltage	20-21 Setpoint 1	22-22 Low Speed Detection	AP-21 Low Power Detection	AP-87 Pressure at No-Flow Speed
6-12 Terminal 53 Low Current	20-22 Setpoint 2	22-23 No-Flow Function	22-22 Low Speed Detection	AP-88 Pressure at Rated Speed
6-13 Terminal 53 High Current	20-81 PID Normal/ Inverse Control	22-24 No-Flow Delay	22-23 No-Flow Function	AP-89 Flow at Design Point
6-14 Terminal 53 Low Ref./Feedb. Value	20-82 PID Start Speed [RPM]	22-40 Minimum Run Time	22-24 No-Flow Delay	AP-90 Flow at Rated Speed
6-15 Terminal 53 High Ref./Feedb. Value	20-83 PID Start Speed [Hz]	22-41 Minimum Sleep Time	22-40 Minimum Run Time	1-03 Torque Characteristics
6-16 Terminal 53 Filter Time Constant	20-93 PID Proportional Gain	22-42 Wake-up Speed [RPM]	22-41 Minimum Sleep Time	1-73 Flying Start
6-17 Terminal 53 Live Zero	20-94 PID Integral Time	22-43 Wake-up Speed [Hz]	22-42 Wake-up Speed [RPM]	Q3-42 Compressor Functions
6-20 Terminal 54 Low Voltage	20-70 Closed-loop Type	22-44 Wake-up Ref./FB Difference	22-43 Wake-up Speed [Hz]	1-03 Torque Characteristics
6-21 Terminal 54 High Voltage	20-71 Tuning Mode	22-45 Setpoint Boost	22-44 Wake-up Ref./FB Difference	1-71 Start Delay
6-22 Terminal 54 Low Current	20-72 PID Output Change	22-46 Maximum Boost Time	22-45 Setpoint Boost	22-75 Short Cycle Protection
6-23 Terminal 54 High Current	20-73 Minimum Feedback Level	2-10 Brake Function	22-46 Maximum Boost Time	22-76 Interval between Starts
6-24 Terminal 54 Low Ref./Feedb. Value	20-74 Maximum Feedback Level	2-16 AC Brake Max. Current		22-77 Minimum Run Time
6-25 Terminal 54 High Ref./Feedb. Value	20-79 PID Auto Tuning	2-17 Over-voltage Control		5-01 Terminal 27 Mode
6-26 Terminal 54 Filter Time Constant	Q3-4 Application Settings	1-73 Flying Start	AP-80 Flow Compensation	5-02 Terminal 29 Mode
6-27 Terminal 54 Live Zero	Q3-40 Fan Functions	1-71 Start Delay	AP-81 Square-linear Curve Approximation	5-12 Terminal 27 Digital Input
6-00 Live Zero Timeout Time	22-60 Broken Belt Function	1-80 Function at Stop	AP-82 Work Point Calculation	5-13 Terminal 29 Digital Input
6-01 Live Zero Timeout Function	22-61 Broken Belt Torque	2-00 DC Hold/Preheat Current	AP-83 Speed at No-Flow [RPM]	5-40 Function Relay
4-56 Warning Feedback Low	22-62 Broken Belt Delay	4-10 Motor Speed Direction	AP-84 Speed at No-Flow [Hz]	1-73 Flying Start
4-57 Warning Feedback High	4-64 Semi-Auto Bypass Set-up	Q3-41 Pump Functions	AP-85 Speed at Design Point [RPM]	1-86 Trip Speed Low [RPM]
20-20 Feedback Function	1-03 Torque Characteristics	AP-20 Low Power Auto Set-up	AP-86 Speed at Design Point [Hz]	1-87 Trip Speed Low [Hz]

Table 5.3 Quick Menu Structure

5.5.2 Main Menu Structure

0-89	Date and Time Readout	1-81	Min Speed for Function at Stop [RPM]	3-82	Starting Ramp Up Time	5-41	On Delay, Relay
1-1*	Load and Motor	1-82	Min Speed for Function at Stop [RPM]	3-84	Initial Ramp Time	5-42	Off Delay, Relay
1-0*	General Settings	1-86	Trip Speed Low [RPM]	3-88	Final Ramp Time	5-5*	Pulse Input
1-03	Configuration Mode	1-87	Trip Speed Low [RPM]	3-90	Step Size	5-50	Term. 29 Low Frequency
1-06	Torque Characteristics	1-9*	Motor Temperature	3-91	Ramp Time	5-51	Term. 29 High Frequency
1-1*	Motor Selection	1-90	Motor Thermal Protection	3-92	Power Restore	5-52	Term. 29 Low Ref./Feedb. Value
1-10	Motor Construction	1-91	Motor External Fan	3-93	Maximum Limit	5-53	Term. 29 High Ref./Feedb. Value
1-1*	VVC+ PM	1-93	Thermistor Source	3-94	Minimum Limit	5-54	Pulse Filter Time Constant #29
1-14	Damping Gain	2-*	Brakes	3-95	Ramp Delay	5-55	Term. 33 Low Frequency
1-15	Low Speed Filter Time Const.	2-0*	DC Brake	4-*	Limits / Warnings	5-56	Term. 33 High Frequency
1-16	High Speed Filter Time Const.	2-00	DC Hold/Preheat Current	4-1*	Motor Limits	5-57	Term. 33 Low Ref./Feedb. Value
1-17	Voltage filter time const.	2-01	DC Brake Current	4-11	Motor Speed Direction	5-58	Term. 33 High Ref./Feedb. Value
1-2*	Motor Data	2-02	DC Braking Time	4-11	Motor Speed Low Limit [RPM]	5-59	Pulse Filter Time Constant #33
1-20	Motor Power [kW]	2-03	DC Brake Cut-in Speed [RPM]	4-12	Motor Speed Low Limit [Hz]	5-60	Pulse Output
1-21	Motor Power [HP]	2-04	DC Brake Cut-in Speed [Hz]	4-13	Motor Speed High Limit [RPM]	5-60	Terminal 27 Pulse Output Variable
1-22	Motor Voltage	2-06	Parking Current	4-14	Motor Speed High Limit [Hz]	5-62	Pulse Output Max Freq #27
1-23	Motor Frequency	2-07	Parking Time	4-16	Torque Limit Motor Mode	5-63	Terminal 29 Pulse Output Variable
1-24	Motor Current	2-1*	Brake Energy Funct.	4-17	Torque Limit Generator Mode	5-65	Pulse Output Max Freq #29
1-25	Motor Nominal Speed	2-10	Brake Function	4-18	Current Limit	5-66	Terminal X30/6 Pulse Output Variable
1-26	Motor Cont. Rated Torque	2-11	Brake Resistor (ohm)	4-19	Max Output Frequency	5-68	Pulse Output Max Freq #X30/6
1-28	Motor Rotation Check	2-12	Brake Power Limit (kW)	4-20	Warning Current Low	5-8*	I/O Options
1-29	Automatic Motor Adaptation (AMA)	2-13	Brake Power Monitoring	4-50	Warning Current High	5-8*	AHF Cap Reconnect Delay
1-3*	Addl. Motor Data	2-15	Brake Check	4-51	Warning Speed Low	5-9*	Bus Controlled
1-30	Custom Readout Unit	2-16	AC Brake Max. Current	4-52	Warning Speed High	5-90	Digital & Relay Bus Control
1-31	Custom Readout Min Value	2-17	Over-voltage Control	4-53	Warning Reference Low	5-93	Pulse Out #27 Bus Control
1-35	Custom Readout Max Value	3-*	Reference / Ramps	4-54	Warning Reference High	5-94	Pulse Out #27 Timeout Preset
1-36	Display Text 1	3-0*	Reference Limits	4-55	Warning Feedback Low	5-95	Pulse Out #29 Bus Control
1-37	Display Text 2	3-02	Minimum Reference	4-56	Warning Feedback High	5-96	Pulse Out #29 Timeout Preset
1-39	Motor Poles	3-03	Maximum Reference	4-57	Warning Feedback Low	5-97	Pulse Out #X30/6 Bus Control
1-40	Back EMF at 1000 RPM	3-04	Reference Function	4-58	Missing Motor Phase Function	5-98	Pulse Out #X30/6 Timeout Preset
1-46	Position Detection Gain	3-1*	References	4-6*	Speed Bypass	6-*	Analog In/Out
1-5*	Load-Indep. Setting	3-10	Preset Reference	4-60	Bypass Speed From [RPM]	6-0*	Analog I/O Mode
1-50	Motor Magnetization at Zero Speed	3-11	Jog Speed [Hz]	4-61	Bypass Speed From [Hz]	6-00	Live Zero Timeout Time
1-51	Min Speed Normal Magnetizing [RPM]	3-13	Reference Site	4-62	Bypass Speed To [RPM]	6-01	Live Zero Timeout Function
1-52	Min Speed Normal Magnetizing [Hz]	3-14	Preset Relative Reference	4-63	Bypass Speed To [Hz]	6-02	Fire Mode Live Zero Timeout Function
1-58	Flystart Test Pulses Current	3-15	Reference 1 Source	4-64	Semi-Auto Bypass Set-up	6-1*	Analog Input 53
1-59	Flystart Test Pulses Frequency	3-16	Reference 2 Source	5-*	Digital In/Out	6-10	Terminal 53 Low Voltage
1-6*	Load-Depend. Settng.	3-17	Reference 3 Source	5-0*	Digital I/O mode	6-11	Terminal 53 High Voltage
1-60	Low Speed Load Compensation	3-19	Jog Speed [RPM]	5-01	Terminal 27 Mode	6-12	Terminal 53 Low Current
1-61	High Speed Load Compensation	3-4*	Ramp 1	5-02	Terminal 29 Mode	6-13	Terminal 53 High Current
1-62	Slip Compensation	3-40	Ramp 1 Type	5-1*	Digital Inputs	6-14	Terminal 53 Low Ref./Feedb. Value
1-63	Slip Compensation Time Constant	3-41	Ramp 1 Ramp-up Time	5-10	Terminal 18 Digital Input	6-15	Terminal 53 High Ref./Feedb. Value
1-64	Resonance Dampening	3-42	Ramp 1 Ramp-down Time	5-11	Terminal 19 Digital Input	6-16	Terminal 53 Filter Time Constant
1-65	Resonance Dampening Time Constant	3-45	Ramp 1 S-ramp Ratio at Accel. Start	5-12	Terminal 27 Digital Input	6-17	Terminal 53 Live Zero
1-66	Min. Current at Low Speed	3-46	Ramp 1 S-ramp Ratio at Decel. End	5-13	Terminal 29 Digital Input	6-2*	Analog Input 54
1-7*	Start Adjustments	3-47	Ramp 1 S-ramp Ratio at Decel. Start	5-14	Terminal 32 Digital Input	6-20	Terminal 54 Low Voltage
1-70	PM Start Mode	3-48	Ramp 1 S-ramp Ratio at Decel. End	5-15	Terminal 33 Digital Input	6-21	Terminal 54 High Voltage
1-71	Start Delay	3-50	Ramp 2 Type	5-16	Terminal X30/2 Digital Input	6-22	Terminal 54 Low Current
1-72	Start Function	3-51	Ramp 2 Ramp-up Time	5-17	Terminal X30/3 Digital Input	6-23	Terminal 54 High Current
1-73	Flying Start	3-52	Ramp 2 Ramp-down Time	5-18	Terminal X30/4 Digital Input	6-24	Terminal 54 Low Ref./Feedb. Value
1-77	Compressor Start Max Speed [RPM]	3-55	Ramp 2 S-ramp Ratio at Accel. Start	5-19	Terminal 37 Safe Stop	6-25	Terminal 54 High Ref./Feedb. Value
1-78	Compressor Start Max Speed [Hz]	3-56	Ramp 2 S-ramp Ratio at Accel. End	5-30	Digital Outputs	6-26	Terminal 54 Filter Time Constant
1-79	Compressor Start Max Time to Trip	3-57	Ramp 2 S-ramp Ratio at Decel. Start	5-30	Terminal 27 Digital Output	6-27	Terminal 54 Live Zero
1-8*	Stop Adjustments	3-58	Ramp 2 S-ramp Ratio at Decel. End	5-31	Terminal 29 Digital Output	6-3*	Analog Input X30/11
1-80	Function at Stop	3-8*	Other Ramps	5-32	Term X30/6 Digi Out (MCB 101)	6-30	Terminal X30/11 Low Voltage
		3-80	Jog Ramp Time	5-33	Term X30/7 Digi Out (MCB 101)	6-31	Terminal X30/11 High Voltage
		3-81	Quick Stop Ramp Time	5-4*	Relays	6-34	Term. X30/11 Low Ref./Feedb. Value
				5-40	Function Relay	6-35	Term. X30/11 High Ref./Feedb. Value

6-36	Term. X30/11 Filter Time Constant	8-72	MS/TP Max Masters	10-07	Readout Bus Off Counter	14-04	PWM Random	15-3*	Alarm Log
6-37	Term. X30/11 Live Zero	8-73	MS/TP Max Info Frames	10-1*	DeviceNet	14-06	Dead Time Compensation	15-30	Alarm Log: Error Code
6-4*	Analog Input X30/12	8-74	"Startup 1 am"	10-10	Process Data Type Selection	14-1*	Mains On/Off	15-31	Alarm Log: Value
6-41	Terminal X30/12 Low Voltage	8-75	Initialisation Password	10-11	Process Data Config Write	14-10	Line Failure	15-32	Alarm Log: Time
6-41	Terminal X30/12 High Voltage	8-75	FC Port Diagnostics	10-12	Process Data Config Read	14-11	Line Voltage at Line Fault	15-33	Alarm Log: Date and Time
6-44	Term. X30/12 Low Ref./Feedb. Value	8-80	Bus Message Count	10-13	Warning Parameter	14-12	Function at Mains Imbalance	15-4*	Drive Identification
6-45	Term. X30/12 High Ref./Feedb. Value	8-81	Bus Error Count	10-14	Net Reference	14-2*	Reset Functions	15-40	FC Type
6-46	Term. X30/12 Filter Time Constant	8-82	Slave Messages Rcvd	10-15	Net Control	14-20	Reset Mode	15-41	Power Section
6-47	Term. X30/12 Live Zero	8-83	Slave Error Count	10-2*	COS Filters	14-21	Automatic Restart Time	15-42	Voltage
6-5*	Analog Output 42	8-84	Slave Messages Sent	10-20	COS Filter 1	14-22	Operation Mode	15-43	Software Version
6-50	Terminal 42 Output	8-85	Slave Timeout Errors	10-21	COS Filter 2	14-23	Typecode Setting	15-44	Ordered Typecode String
6-51	Terminal 42 Output Min Scale	8-88	Reset FC Port Diagnostics	10-22	COS Filter 3	14-25	Trip Delay at Torque Limit	15-45	Actual Typecode String
6-52	Terminal 42 Output Max Scale	8-89	Diagnosics Count	10-23	COS Filter 4	14-26	Trip Delay at Inverter Fault	15-46	Adj Freq Dr Ordering No.
6-53	Terminal 42 Output Bus Control	8-9*	Bus Jog	10-3*	Parameter Access	14-28	Production Settings	15-47	Power Card Ordering No.
6-54	Terminal 42 Output Timeout Preset	8-90	Bus Jog 1 Speed	10-30	Array Index	14-29	Service Code	15-48	LCP ID Num.
6-55	Analog Output Filter	8-91	Bus Jog 2 Speed	10-31	Store Data Values	14-3*	Current Limit Ctrl.	15-49	SW ID Control Card
6-6*	Analog Output X30/8	8-94	Bus Feedback 1	10-32	DeviceNet Revision	14-30	Current Lim Ctrl, Proportional Gain	15-50	SW ID Power Card
6-60	Terminal X30/8 Output	8-95	Bus Feedback 2	10-33	Store Always	14-31	Current Lim Ctrl, Integration Time	15-51	Adj Freq Dr Serial No.
6-61	Terminal X30/8 Min. Scale	8-96	Bus Feedback 3	10-34	DeviceNet Product Code	14-32	Current Lim Ctrl, Filter Time	15-53	Power Card Serial Number
6-62	Terminal X30/8 Max. Scale	9-9*	Profibus	10-39	DeviceNet F. Parameters	14-4*	Energy Optimizing	15-55	Vendor URL
6-63	Terminal X30/8 Output Bus Control	9-00	Setpoint	11-1**	LonWorks	14-40	VT Level	15-56	Vendor Name
6-64	Terminal X30/8 Output Timeout Preset	9-07	Actual Value	11-0*	LonWorks ID	14-41	AEO Minimum Magnetization	15-59	CSV Filename
8-8**	Comm. and Options	9-15	PCD Write Configuration	11-00	Neuron ID	14-42	Minimum AEO Frequency	15-6*	Option Ident
8-0*	General Settings	9-16	PCD Read Configuration	11-01	Domain	14-43	Motor Cos-Phi	15-60	Option Mounted
8-01	Control Site	9-22	Node Address	11-02	Subnet ID	14-5*	Environment	15-61	Option SW Version
8-02	Control Source	9-23	Telegram Selection	11-03	Node ID	14-50	RFI 1	15-62	Option Ordering No
8-03	Control Timeout Time	9-27	Parameters for Signals	11-1*	LON Functions	14-51	DC Link Compensation	15-63	Option Serial No
8-04	Control Timeout Function	9-27	Parameter Edit	11-10	Drive Profile	14-52	Fan Control	15-70	Option in Slot A
8-05	End-of-Timeout Function	9-44	Process Control	11-15	LON Warning Word	14-53	Fan Monitor	15-71	Option in Slot B
8-06	Reset Control Timeout	9-44	Fault Message Counter	11-17	XIF Revision	14-55	Output Filter	15-72	Option in Slot C
8-07	Diagnosis Trigger	9-45	Fault Code	11-18	LonWorks Revision	14-59	Actual Number of Inverter Units	15-73	Slot B Option SW Version
8-08	Readout Filtering	9-52	Fault Number	11-2*	LON Param. Access	14-6*	Auto Derate	15-74	Option in Slot C0
8-09	Communication Charset	9-53	Fault Situation Counter	11-21	Store Data Values	14-60	Function at Overtemperature	15-75	Slot C0/E0 Option SW Version
8-1*	Control Settings	9-63	Profibus Warning Word	13-3**	Smart Logic	14-61	Function at Inverter Overload	15-76	Option in Slot C1
8-10	Control Profile	9-64	Actual Baud Rate	13-00	SLC Settings	14-62	Inv. Overload Derate Current	15-77	Slot C1/E1 Option SW Version
8-13	Configurable Status Word STW	9-65	Device Identification	13-01	Start Event	14-9*	Fault Settings	15-8*	Operating Data II
8-3*	FC Port Settings	9-67	Profile Number	13-02	Stop Event	14-90	Fault Level	15-80	Fan Running Hours
8-30	Protocol	9-68	Control Word 1	13-03	Reset SLC	15-0*	Drive Information	15-81	Preset Fan Running Hours
8-31	Address	9-71	Status Word 1	13-1*	Comparators	15-0*	Operating Data	15-9*	Parameter Info
8-32	Baud Rate	9-72	ProfibusSave Data Values	13-10	Comparator Operand	15-00	Operating hours	15-92	Defined Parameters
8-33	Parity / Stop Bits	9-80	Defined Parameters (1)	13-11	Comparator Operator	15-01	Running Hours	15-93	Modified Parameters
8-34	Estimated cycle time	9-81	Defined Parameters (2)	13-12	Comparator Operator	15-02	Input kWh Counter	15-98	Drive Identification
8-35	Minimum Response Delay	9-82	Defined Parameters (3)	13-2*	Timers	15-03	Power-ups	15-99	Parameter Metadata
8-36	Maximum Response Delay	9-83	Defined Parameters (4)	13-20	SL Controller Timer	15-04	Over Temps	16-6**	Data Readouts
8-37	Maximum Inter-Char Delay	9-84	Defined Parameters (5)	13-40	Logic Rules	15-05	Over Volts	16-0*	General Status
8-4*	FC MC protocol set	9-90	Changed Parameters (1)	13-40	Logic Rule Boolean 1	15-06	Reset kWh Counter	16-00	Control Word
8-40	Telegram selection	9-91	Changed Parameters (2)	13-41	Logic Rule Boolean 2	15-07	Reset Running Hours Counter	16-01	Reference [Unit]
8-42	PCD Write Configuration	9-92	Changed Parameters (3)	13-42	Logic Rule Boolean 3	15-08	Number of Starts	16-02	Reference [%]
8-43	PCD Read Configuration	9-93	Changed parameters (4)	13-43	Logic Rule Operator 1	15-1*	Data Log Settings	16-03	Status Word
8-5*	Digital/Bus	9-94	Changed parameters (5)	13-43	Logic Rule Operator 2	15-10	Logging Source	16-05	Main Actual Value [%]
8-50	Coasting Select	9-99	Profibus Revision Counter	13-51	States	15-11	Logging Interval	16-09	Custom Readout
8-52	DC Brake Select	10-0**	CAN Fieldbus	13-51	SL Controller Event	15-12	Trigger Event	16-1*	Motor Status
8-53	Start Select	10-0*	Common Settings	13-52	SL Controller Action	15-13	Logging Mode	16-10	Input Power [kW]
8-54	Reverse Select	10-00	CAN Protocol	14-3**	Special Functions	15-14	Samples Before Trigger	16-11	Input Power [hp]
8-55	Set-up Select	10-01	Baud Rate Select	14-0*	Inverter Switching	15-2*	Historic Log	16-12	Motor voltage
8-56	Preset Reference Select	10-02	MAC ID	14-00	Switching Pattern	15-20	Historic Log: Event	16-13	Frequency
8-7*	BACnet	10-05	Readout Transmit Error Counter	14-01	Switching Frequency	15-21	Historic Log: Value	16-14	Motor current
8-70	BACnet Device Instance	10-06	Readout Receive Error Counter	14-03	Overmodulation	15-22	Historic Log: Time	16-15	Frequency [%]
						15-23	Historic Log: Date and Time	16-16	Torque [Nm]

16-17	Speed [RPM]	18-00	Maintenance Log: Item	20-93	PID Proportional Gain	21-64	Ext. 3 Dif. Gain Limit	23-81	Energy Cost
16-18	Motor Thermal	18-01	Maintenance Log: Action	20-94	PID Integral Time	22-2*	Application Functions	23-82	Investment
16-22	Torque [%]	18-02	Maintenance Log: Time	20-95	PID Differentiation Time	22-0*	Miscellaneous	23-83	Energy Savings
16-3*	Drive Status	18-03	Maintenance Log: Date and Time	20-96	PID Dif. Gain Limit	22-2*	External Interlock Delay	23-84	Cost Savings
16-30	DC Link Voltage	18-1*	Fire Mode Log	21-2*	Ext. Closed-loop	22-2*	No-Flow Detection	24-2*	Appl. Functions 2
16-32	Brake Energy /s	18-10	Fire Mode Log: Event	21-0*	Ext. PID Auto-tuning	22-22	Low Speed Detection	24-0*	Fire Mode
16-33	Brake Energy /2 min	18-11	Fire Mode Log: Time	21-00	Closed-loop Type	22-23	No-Flow Function	24-00	Fire Mode Function
16-34	Heatsink Temp.	18-12	Fire Mode Log: Date and Time	21-01	Tuning Mode	22-24	No-Flow Delay	24-03	Fire Mode Min Reference
16-35	Inverter Thermal	18-4*	PGIO Data Readouts	21-02	PID Output Change	22-4*	Sleep Mode	24-04	Fire Mode Max Reference
16-36	Inv. Nom. Current	18-40	Analog Input X49/1	21-03	Minimum Feedback Level	22-40	Minimum Run Time	24-05	Fire Mode Preset Reference
16-37	Inv. Max. Current	18-41	Analog Input X49/3	21-04	Maximum Feedback Level	22-41	Minimum Sleep Time	24-06	Fire Mode Reference Source
16-38	SL Controller State	18-42	Analog Input X49/5	21-09	PID Autotuning	22-42	Wake-up Speed [RPM]	24-09	Fire Mode Alarm Handling
16-39	Control Card Temp.	18-43	Analog Output X49/7	21-1*	Ext. CL 1 Ref/Fb.	22-43	Wake-up Speed [Hz]	24-1*	Drive Bypass
16-40	Logging Buffer Full	18-44	Analog Output X49/9	21-10	Ext. 1 Ref./Feedback Unit	22-44	Wake-up Ref./FB Difference	24-10	Bypass Function
16-41	Logging Buffer Full	18-45	Analog Output X49/11	21-11	Ext. 1 Minimum Reference	22-45	Setpoint Boost	24-11	Bypass Delay Time
16-43	Timed Actions Status	18-46	X49 Digital Output [bin]	21-12	Ext. 1 Maximum Reference	22-6*	Maximum Boost Time	24-9*	Multi-Motor Function
16-49	Current Fault Source	20-2*	Drive Closed-loop	21-13	Ext. 1 Reference Source	22-6*	Broken Belt Detection	24-90	Missing Motor Function
16-5*	Ref. & Feedsb.	20-0*	Feedback	21-14	Ext. 1 Feedback Source	22-60	Broken Belt Function	24-91	Missing Motor Coefficient 1
16-50	External Reference	20-00	Feedback 1 Source	21-15	Ext. 1 Setpoint	22-61	Broken Belt Torque	24-92	Missing Motor Coefficient 2
16-52	Feedback [Unit]	20-01	Feedback 1 Conversion	21-17	Ext. 1 Reference [Unit]	22-62	Broken Belt Delay	24-93	Missing Motor Coefficient 3
16-53	Digi Pot Reference	20-02	Feedback 1 Source Unit	21-18	Ext. 1 Feedback [Unit]	22-7*	Short Cycle Protection	24-94	Missing Motor Coefficient 4
16-54	Feedback 1 [Unit]	20-03	Feedback 2 Source	21-19	Ext. 1 Output [%]	22-75	Short Cycle Protection	24-95	Locked Rotor Function
16-55	Feedback 2 [Unit]	20-04	Feedback 2 Conversion	21-2*	Ext. CL 1 PID	22-76	Interval between Starts	24-96	Locked Rotor Coefficient 1
16-56	Feedback 3 [Unit]	20-05	Feedback 2 Source Unit	21-20	Ext. 1 Normal/Inverse Control	22-77	Minimum Run Time	24-97	Locked Rotor Coefficient 2
16-58	PID Output [%]	20-06	Feedback 3 Source	21-21	Ext. 1 Proportional Gain	23-3*	Time-based Functions	24-98	Locked Rotor Coefficient 3
16-6*	Inputs & Outputs	20-07	Feedback 3 Conversion	21-22	Ext. 1 Integral Time	23-00	ON Time	24-99	Locked Rotor Coefficient 4
16-60	Digital Input	20-08	Feedback 3 Source Unit	21-23	Ext. 1 Differentiation Time	23-00	ON Time	30-2*	Special Features
16-61	Terminal 53 Switch Setting	20-12	Reference/Feedback Unit	21-24	Ext. 1 Dif. Gain Limit	23-01	ON Action	30-2*	Adv. Start Adjust
16-62	Analog Input 53	20-13	Minimum Reference/Feedb.	21-3*	Ext. CL 2 Ref/Fb.	23-02	OFF Time	30-22	Locked Rotor Detection
16-63	Terminal 54 Switch Setting	20-14	Maximum Reference/Feedb.	21-30	Ext. 2 Ref./Feedback Unit	23-03	OFF Action	30-23	Locked Rotor Detection Time [s]
16-64	Analog Input 54	20-2*	Feedback & Setpoint	21-31	Ext. 2 Minimum Reference	23-0*	Time-based Functions	31-1*	Bypass Option
16-65	Analog Output 42 [mA]	20-20	Feedback Function	21-32	Ext. 2 Maximum Reference	23-08	Timed Actions Set.	31-00	Bypass Mode
16-66	Digital Output [bin]	20-21	Setpoint 1	21-33	Ext. 2 Reference Source	23-08	Timed Actions Mode	31-01	Bypass Start Time Delay
16-67	Pulse Input #29 [Hz]	20-22	Setpoint 2	21-34	Ext. 2 Feedback Source	23-09	Timed Actions Reactivation	31-02	Bypass Trip Time Delay
16-68	Pulse Input #33 [Hz]	20-23	Setpoint 3	21-35	Ext. 2 Setpoint	23-1*	Maintenance	31-03	Test Mode Activation
16-69	Pulse Output #27 [Hz]	20-3*	Feedb. Adv. Conv.	21-37	Ext. 2 Reference [Unit]	23-10	Maintenance Item	31-10	Bypass Status Word
16-70	Pulse Output #29 [Hz]	20-30	Refrigerant	21-38	Ext. 2 Feedback [Unit]	23-11	Maintenance Action	31-11	Bypass Running Hours
16-71	Relay Output [bin]	20-31	User-defined Refrigerant A1	21-39	Ext. 2 Output [%]	23-12	Maintenance Time Base	36-1*	Remote Bypass Activation
16-72	Counter A	20-32	User-defined Refrigerant A2	21-4*	Ext. CL 2 PID	23-13	Maintenance Time Interval	36-0*	I/O Mode
16-73	Counter B	20-33	User-defined Refrigerant A3	21-40	Ext. 2 Normal/Inverse Control	23-14	Maintenance Date and Time	36-00	Terminal X49/1 Mode
16-75	Analog In X30/11	20-34	Duct 1 Area [m2]	21-41	Ext. 2 Proportional Gain	23-1*	Maintenance Reset	36-01	Terminal X49/3 Mode
16-76	Analog In X30/12	20-35	Duct 1 Area [m2]	21-42	Ext. 2 Integral Time	23-15	Reset Maintenance Word	36-02	Terminal X49/5 Mode
16-77	Analog Out X30/8 [mA]	20-36	Duct 2 Area [m2]	21-43	Ext. 2 Differentiation Time	23-16	Maintenance Text	36-03	Terminal X49/7 Mode
16-8*	Fieldbus & FC Port	20-37	Duct 2 Area [m2]	21-44	Ext. 2 Dif. Gain Limit	23-5*	Energy Log	36-04	Terminal X49/9 Mode
16-80	Fieldbus CTW 1	20-38	Air Density Factor [%]	21-5*	Ext. CL 3 Ref/Fb.	23-50	Energy Log Resolution	36-05	Terminal X49/11 Mode
16-82	Fieldbus REF 1	20-7*	PID Auto Tuning	21-50	Ext. 3 Ref./Feedback Unit	23-51	Period Start	36-1*	Analog Input X49/1
16-84	Comm. Option Status	20-70	Closed-loop Type	21-51	Ext. 3 Minimum Reference	23-53	Energy Log	36-10	Terminal X49/1 Low Voltage
16-85	FC Port CTW 1	20-71	Tuning Mode	21-52	Ext. 3 Maximum Reference	23-54	Reset Energy Log	36-11	Terminal X49/1 Low Current
16-86	FC Port REF 1	20-72	PID Output Change	21-53	Ext. 3 Reference Source	23-6*	Trending	36-12	Terminal X49/1 High Voltage
16-9*	Diagnosis Readouts	20-73	Minimum Feedback Level	21-54	Ext. 3 Feedback Source	23-60	Trend Variable	36-13	Terminal X49/1 High Current
16-90	Alarm Word	20-74	Maximum Feedback Level	21-55	Ext. 3 Setpoint	23-61	Continuous Bin Data	36-14	Term. X49/1 Low Ref./Feedb. Value
16-91	Alarm Word 2	20-79	PID Auto Tuning	21-57	Ext. 3 Reference [Unit]	23-62	Timed Bin Data	36-15	Term. X49/1 High Ref./Feedb. Value
16-92	Warning Word	20-8*	PID Basic Settings	21-58	Ext. 3 Feedback [Unit]	23-63	Timed Period Start	36-16	Term. X49/1 Filter Time Constant
16-93	Warning Word 2	20-81	PID Normal/Inverse Control	21-59	Ext. 3 Output [%]	23-65	Minimum Bin Value	36-2*	Analog Input X49/3
16-94	Ext. Status Word	20-82	PID Start Speed [RPM]	21-6*	Ext. CL 3 PID	23-66	Reset Continuous Bin Data	36-20	Terminal X49/3 Low Voltage
16-95	Ext. Status Word 2	20-83	PID Start Speed [Hz]	21-60	Ext. 3 Normal/Inverse Control	23-67	Reset Timed Bin Data	36-21	Terminal X49/3 Low Current
16-96	Maintenance Word	20-84	On Reference Bandwidth	21-62	Ext. 3 Proportional Gain	23-8*	Payback Counter	36-22	Terminal X49/3 High Voltage
18-1*	Info & Readouts	20-9*	PID Controller	21-63	Ext. 3 Differentiation Time	23-80	Power Reference Factor		
18-0*	Maintenance Log	20-91	PID Anti Windup						

36-23	Terminal X49/3 High Current
36-24	Term. X49/3 Low Ref./Feedb. Value
36-25	Term. X49/3 High Ref./Feedb. Value
36-26	Term. X49/3 Filter Time Constant
36-27	Term. X49/3 Live Zero
36-3*	Analog Input X49/5
36-30	Terminal X49/5 Low Voltage
36-31	Terminal X49/5 Low Current
36-32	Terminal X49/5 High Voltage
36-33	Terminal X49/5 High Current
36-34	Term. X49/5 Low Ref./Feedb. Value
36-35	Term. X49/5 High Ref./Feedb. Value
36-36	Term. X49/5 Filter Time Constant
36-37	Term. X49/5 Live Zero
36-4*	Output X49/7
36-40	Terminal X49/7 Analog Output
36-41	Terminal X49/7 Digital Output
36-42	Terminal X49/7 Min. Scale
36-43	Terminal X49/7 Max. Scale
36-44	Terminal X49/7 Bus Control
36-45	Terminal X49/7 Timeout Preset
36-5*	Output X49/9
36-50	Terminal X49/9 Analog Output
36-51	Terminal X49/9 Digital Output
36-52	Terminal X49/9 Min. Scale
36-53	Terminal X49/9 Max. Scale
36-54	Terminal X49/9 Bus Control
36-55	Terminal X49/9 Timeout Preset
36-6*	Output X49/11
36-60	Terminal X49/11 Analog Output
36-61	Terminal X49/11 Digital Output
36-62	Terminal X49/11 Min. Scale
36-63	Terminal X49/11 Max. Scale
36-64	Terminal X49/11 Bus Control
36-65	Terminal X49/11 Timeout Preset

5.6 Dedicated Factory Settings

Adjustable frequency drives delivered as part of a Trane equipment can have dedicated factory settings. Upon factory reset of the adjustable frequency drive, these parameter settings will be used as default. See below for details on the specific equipment settings.

Parameter	Trane default value
0-01 Language	[22] English US
0-03 Regional Settings	[1] North America
0-20 Display Line 1.1 Small	[1662] Analog Input 53
0-22 Display Line 1.3 Small	[1611] Power [hp]
0-40 [Hand on] Key on LCP	[0] Disabled
1-03 Torque Character- istics	[1] Variable
1-21 Motor Power [HP]	Reference Motor Nameplate HP
1-22 Motor Voltage	Reference Motor Nameplate Voltage
1-24 Motor Current	Reference Motor Nameplate FLA
1-25 Motor Nominal Speed	Reference Motor Nameplate Rated Speed
1-73 Flying Start	[1] Enabled
2-00 DC Hold/Preheat Current	0%
2-01 DC Brake Current	0%
2-04 DC Brake Cut-in Speed [Hz]	10 Hz
3-41 Ramp 1 Ramp-up Time	30 sec
3-42 Ramp 1 Ramp-down Time	30 sec
4-12 Motor Speed Low Limit [Hz]	22 Hz IntelliPak 35 Hz Voyager III
4-18 Current Limit	100%
5-12 Terminal 27 Digital Input	[2] Coast Inverse
6-14 Terminal 53 Low Ref./Feedb. Value	22 Hz IntelliPak 35 Hz Voyager III
14-01 Switching Frequency	208/203 V, 30 HP and below 8 kHz, above 5 kHz 460/575 V, 60 HP and below 8 kHz, above 5 kHz
14-12 Function at Mains Imbalance	[3] Derate
14-20 Reset Mode	[3] Automatic reset x 3
14-60 Function at Overtemperature	[1] Derate
14-61 Function at Inverter Overload	[1] Derate

Table 5.4 Trane IntelliPak™, IntelliPak™ II, and Voyager III™

Parameter	Trane default value
0-03 Regional Settings	[1] North America
1-21 Motor Power [HP]	Reference Motor Nameplate HP
1-22 Motor Voltage	Reference Motor Nameplate Voltage
1-24 Motor Current	Reference Motor Nameplate FLA
1-25 Motor Nominal Speed	Reference Motor Nameplate Rated Speed
1-73 Flying Start	[Enabled]
3-03 Maximum Reference	60 Hz or (for direct drive) Set for Application
3-41 Ramp 1 Ramp-up Time	30 sec
3-42 Ramp 1 Ramp-down Time	30 sec
4-12 Motor Speed Low Limit [Hz]	20 Hz
4-14 Motor Speed High Limit [Hz]	60 Hz or (for direct drive) Set for Application
5-12 Terminal 27 Digital Input	[2] Coast Inverse
6-14 Terminal 53 Low Ref./Feedb. Value	20 Hz
6-15 Terminal 53 High Ref./Feedb. Value	60 Hz or (for direct drive) Set for Application
14-01 Switching Frequency	208/230 V, 30 HP and below 8 kHz, above 5 kHz 460/575 V, 60 HP and below 8 kHz, above 5 kHz

Table 5.5 Trane M-Series and T-Series Climate Changer™, Performance Climate Changer™ - Indoor & Outdoor

Parameter	Trane default value
0-01 Language	[22] English US
0-03 Regional Settings	[1] North America
0-22 Display Line 1.3 Small	[1611] Power [HP]
1-21 Motor Power [HP]	Reference Motor Nameplate HP
1-22 Motor Voltage	Reference Motor Nameplate Voltage
1-24 Motor Current	Reference Motor Nameplate FLA
1-25 Motor Nominal Speed	Reference Motor Nameplate Rated Speed
1-73 Flying Start	[1] Enabled
3-41 Ramp 1 Ramp-up Time	30 sec
3-42 Ramp 1 Ramp-down Time	30 sec
4-12 Motor Speed Low Limit [Hz]	22 Hz

Parameter	Trane default value
5-12 Terminal 27 Digital Input	[2] Coast Inverse, Commercial Self Contained [0] No operation, Packaged Climate Changer
6-14 Terminal 53 Low Ref./Feedb. Value	22 Hz
14-01 Switching Frequency	8 kHz
14-12 Function at Mains Imbalance	[3] Derate
14-21 Automatic Restart Time	3 sec
14-60 Function at Overtemperature	[1] Derate

Table 5.6 Trane Commercial Self Contained and Packaged Climate Changer™

5.7 Remote Programming with Trane Drive Utility (TDU)

Trane has a software program available for developing, storing, and transferring adjustable frequency drive programming. The Trane Drive Utility (TDU) allows the user to connect a PC to the adjustable frequency drive and perform live programming rather than using the LCP. Additionally, all adjustable frequency drive programming can be done off-line and simply downloaded to the adjustable frequency drive. Or the entire adjustable frequency drive profile can be loaded onto the PC for backup storage or analysis.

The USB connector or RS-485 terminal is available for connecting to the adjustable frequency drive.

6 Application Set-up Examples

6.1 Introduction

The examples in this section are intended as a quick reference for common applications.

- Parameter settings are the regional default values unless otherwise indicated (selected in 0-03 Regional Settings).
- Parameters associated with the terminals and their settings are shown next to the drawings.
- Where switch settings for analog terminals A53 or A54 are required, these are also shown.

6.2 Application Examples

FC		Parameters	
		Function	Setting
+24 V	12	1-29 Automatic Motor Adaptation (AMA)	[1] Enable complete AMA
+24 V	13		
D IN	18		
D IN	19		
COM	20		
D IN	27	5-12 Terminal 27 Digital Input	[2]* Coast inverse
D IN	29	* = Default Value	
D IN	32	Notes/comments: Parameter group 1-2* must be set according to motor D IN 37 is an option.	
D IN	33		
D IN	37		
+10 V	50		
A IN	53		
A IN	54		
COM	55		
A OUT	42		
COM	39		

Table 6.1 AMA with T27 Connected

FC		Parameters	
		Function	Setting
+24 V	12	1-29 Automatic Motor Adaptation (AMA)	[1] Enable complete AMA
+24 V	13		
D IN	18		
D IN	19		
COM	20		
D IN	27	5-12 Terminal 27 Digital Input	[0] No operation
D IN	29	* = Default Value	
D IN	32	Notes/comments: Parameter group 1-2* must be set according to motor D IN 37 is an option.	
D IN	33		
D IN	37		
+10 V	50		
A IN	53		
A IN	54		
COM	55		
A OUT	42		
COM	39		

Table 6.2 AMA without T27 Connected

FC		Parameters	
		Function	Setting
+24 V	12	6-10 Terminal 53 Low Voltage	0.07 V*
+24 V	13		
D IN	18		
D IN	19		
COM	20		
D IN	27	6-11 Terminal 53 High Voltage	10 V*
D IN	29	6-14 Terminal 53 Low Ref./Feedb. Value	0 RPM
D IN	32		
D IN	33		
D IN	37	6-15 Terminal 53 High Ref./Feedb. Value	1500 RPM
+10 V	50	* = Default Value	
A IN	53	Notes/comments: D IN 37 is an option.	
A IN	54		
COM	55		
A OUT	42		
COM	39		

Table 6.3 Analog Speed Reference (Voltage)

		Parameters	
FC		Function	Setting
+24 V	12	6-12 Terminal 53	4 mA*
+24 V	13	Low Current	
D IN	18	6-13 Terminal 53	20 mA*
D IN	19	High Current	
COM	20	6-14 Terminal 53	0 RPM
D IN	27	Low Ref./Feedb. Value	
D IN	29	6-15 Terminal 53	1500 RPM
D IN	32	High Ref./Feedb. Value	
D IN	33		
D IN	37		
+10 V	50	* = Default Value	
A IN	53	Notes/comments:	
A IN	54	D IN 37 is an option.	
COM	55		
A OUT	42		
COM	39		

Table 6.4 Analog Speed Reference (Current)

		Parameters	
FC		Function	Setting
+24 V	12	5-10 Terminal 18	[9] Latched Start
+24 V	13	Digital Input	
D IN	18	5-12 Terminal 27	[6] Stop Inverse
D IN	19	Digital Input	
COM	20	* = Default Value	
D IN	27	Notes/comments:	
D IN	29	If 5-12 Terminal 27 Digital Input is set to [0] No operation, a jumper wire to terminal 27 is not needed.	
D IN	32	D IN 37 is an option.	
D IN	33		
D IN	37		
+10 V	50		
A IN	53		
A IN	54		
COM	55		
A OUT	42		
COM	39		

Table 6.5 Pulse Start/Stop

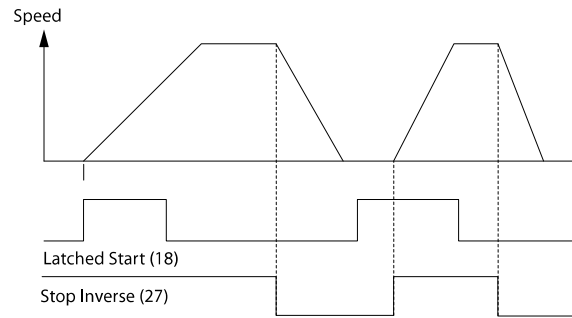

Figure 6.1 Latched Start/Stop Inverse

		Parameters	
FC		Function	Setting
+24 V	12	5-10 Terminal 18	[8] Start
+24 V	13	Digital Input	
D IN	18	5-11 Terminal 19	[10] Reversing*
D IN	19	Digital Input	
COM	20		
D IN	27	5-12 Terminal 27	[0] No operation
D IN	29	Digital Input	
D IN	32	5-14 Terminal 32	[16] Preset ref bit 0
D IN	33	Digital Input	
D IN	37	5-15 Terminal 33	[17] Preset ref bit 1
+10 V	50		
A IN	53		
A IN	54		
COM	55	3-10 Preset Reference	
A OUT	42	Preset ref. 0	25%
COM	39	Preset ref. 1	50%
		Preset ref. 2	75%
		Preset ref. 3	100%
		* = Default Value	
		Notes/comments:	
		D IN 37 is an option.	

Table 6.6 Start/Stop with Reversing and Four Preset Speeds

		Parameters	
		Function	Setting
		5-11 Terminal 19 <i>Digital Input</i>	[1] Reset
		* = Default Value	
		Notes/comments: D IN 37 is an option.	

Table 6.7 External Alarm Reset

		Parameters	
		Function	Setting
		5-10 Terminal 18 <i>Digital Input</i>	[8] Start*
		5-12 Terminal 27 <i>Digital Input</i>	[19] Freeze Reference
		5-13 Terminal 29 <i>Digital Input</i>	[21] Speed Up
		5-14 Terminal 32 <i>Digital Input</i>	[22] Slow
		* = Default Value	
		Notes/comments: D IN 37 is an option.	

Table 6.9 Speed Up/Down

		Parameters	
		Function	Setting
		6-10 Terminal 53 <i>Low Voltage</i>	0.07 V*
		6-11 Terminal 53 <i>High Voltage</i>	10 V*
		6-14 Terminal 53 <i>Low Ref./Feedb. Value</i>	0 RPM
		6-15 Terminal 53 <i>High Ref./Feedb. Value</i>	1500 RPM
		* = Default Value	
		Notes/comments: D IN 37 is an option.	

Table 6.8 Speed Reference (using a Manual Potentiometer)

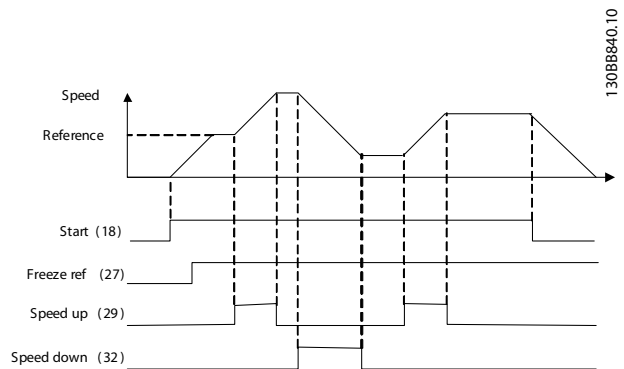

Figure 6.2 Speed Up/Down

		Parameters																																																																									
		Function	Setting																																																																								
<table border="1"> <thead> <tr> <th colspan="2">FC</th> </tr> </thead> <tbody> <tr><td>+24 V</td><td>12</td></tr> <tr><td>+24 V</td><td>13</td></tr> <tr><td>D IN</td><td>18</td></tr> <tr><td>D IN</td><td>19</td></tr> <tr><td>COM</td><td>20</td></tr> <tr><td>D IN</td><td>27</td></tr> <tr><td>D IN</td><td>29</td></tr> <tr><td>D IN</td><td>32</td></tr> <tr><td>D IN</td><td>33</td></tr> <tr><td>D IN</td><td>37</td></tr> <tr><td colspan="2"> </td></tr> <tr><td>+10 V</td><td>50</td></tr> <tr><td>A IN</td><td>53</td></tr> <tr><td>A IN</td><td>54</td></tr> <tr><td>COM</td><td>55</td></tr> <tr><td>A OUT</td><td>42</td></tr> <tr><td>COM</td><td>39</td></tr> <tr><td colspan="2"> </td></tr> <tr><td>R1</td><td>01</td></tr> <tr><td></td><td>02</td></tr> <tr><td></td><td>03</td></tr> <tr><td colspan="2"> </td></tr> <tr><td>R2</td><td>04</td></tr> <tr><td></td><td>05</td></tr> <tr><td></td><td>06</td></tr> <tr><td colspan="2"> </td></tr> <tr><td></td><td>61</td></tr> <tr><td></td><td>68</td></tr> <tr><td></td><td>69</td></tr> </tbody> </table>		FC		+24 V	12	+24 V	13	D IN	18	D IN	19	COM	20	D IN	27	D IN	29	D IN	32	D IN	33	D IN	37			+10 V	50	A IN	53	A IN	54	COM	55	A OUT	42	COM	39			R1	01		02		03			R2	04		05		06				61		68		69	1308B685.10	<table border="1"> <tbody> <tr><td>8-30 Protocol</td><td>FC*</td></tr> <tr><td>8-31 Address</td><td>1*</td></tr> <tr><td>8-32 Baud Rate</td><td>9600*</td></tr> <tr><td colspan="2">* = Default Value</td></tr> <tr><td colspan="2">Notes/comments:</td></tr> <tr><td colspan="2">Select protocol, address and baud rate in the above mentioned parameters. D IN 37 is an option.</td></tr> </tbody> </table>	8-30 Protocol	FC*	8-31 Address	1*	8-32 Baud Rate	9600*	* = Default Value		Notes/comments:		Select protocol, address and baud rate in the above mentioned parameters. D IN 37 is an option.	
FC																																																																											
+24 V	12																																																																										
+24 V	13																																																																										
D IN	18																																																																										
D IN	19																																																																										
COM	20																																																																										
D IN	27																																																																										
D IN	29																																																																										
D IN	32																																																																										
D IN	33																																																																										
D IN	37																																																																										
+10 V	50																																																																										
A IN	53																																																																										
A IN	54																																																																										
COM	55																																																																										
A OUT	42																																																																										
COM	39																																																																										
R1	01																																																																										
	02																																																																										
	03																																																																										
R2	04																																																																										
	05																																																																										
	06																																																																										
	61																																																																										
	68																																																																										
	69																																																																										
8-30 Protocol	FC*																																																																										
8-31 Address	1*																																																																										
8-32 Baud Rate	9600*																																																																										
* = Default Value																																																																											
Notes/comments:																																																																											
Select protocol, address and baud rate in the above mentioned parameters. D IN 37 is an option.																																																																											

Table 6.10 RS-485 Network Connection

		Parameters																																															
		Function	Setting																																														
<table border="1"> <thead> <tr> <th colspan="2">FC</th> </tr> </thead> <tbody> <tr><td>+24 V</td><td>12</td></tr> <tr><td>+24 V</td><td>13</td></tr> <tr><td>D IN</td><td>18</td></tr> <tr><td>D IN</td><td>19</td></tr> <tr><td>COM</td><td>20</td></tr> <tr><td>D IN</td><td>27</td></tr> <tr><td>D IN</td><td>29</td></tr> <tr><td>D IN</td><td>32</td></tr> <tr><td>D IN</td><td>33</td></tr> <tr><td>D IN</td><td>37</td></tr> <tr><td colspan="2"> </td></tr> <tr><td>+10 V</td><td>50</td></tr> <tr><td>A IN</td><td>53</td></tr> <tr><td>A IN</td><td>54</td></tr> <tr><td>COM</td><td>55</td></tr> <tr><td>A OUT</td><td>42</td></tr> <tr><td>COM</td><td>39</td></tr> </tbody> </table>		FC		+24 V	12	+24 V	13	D IN	18	D IN	19	COM	20	D IN	27	D IN	29	D IN	32	D IN	33	D IN	37			+10 V	50	A IN	53	A IN	54	COM	55	A OUT	42	COM	39	1308B686.11	<table border="1"> <tbody> <tr><td>1-90 Motor Thermal Protection</td><td>[2]</td></tr> <tr><td>1-93 Thermistor Source</td><td>[1] Analog input 53</td></tr> <tr><td colspan="2">* = Default Value</td></tr> <tr><td colspan="2">Notes/comments:</td></tr> <tr><td colspan="2">If only a warning is desired, 1-90 Motor Thermal Protection should be set to [1] Thermistor warning. D IN 37 is an option.</td></tr> </tbody> </table>	1-90 Motor Thermal Protection	[2]	1-93 Thermistor Source	[1] Analog input 53	* = Default Value		Notes/comments:		If only a warning is desired, 1-90 Motor Thermal Protection should be set to [1] Thermistor warning. D IN 37 is an option.	
FC																																																	
+24 V	12																																																
+24 V	13																																																
D IN	18																																																
D IN	19																																																
COM	20																																																
D IN	27																																																
D IN	29																																																
D IN	32																																																
D IN	33																																																
D IN	37																																																
+10 V	50																																																
A IN	53																																																
A IN	54																																																
COM	55																																																
A OUT	42																																																
COM	39																																																
1-90 Motor Thermal Protection	[2]																																																
1-93 Thermistor Source	[1] Analog input 53																																																
* = Default Value																																																	
Notes/comments:																																																	
If only a warning is desired, 1-90 Motor Thermal Protection should be set to [1] Thermistor warning. D IN 37 is an option.																																																	

Table 6.11 Motor Thermistor

CAUTION

Thermistors must use reinforced or double insulation to meet PELV insulation requirements.

7 Status Messages

7.1 Status Display

When the adjustable frequency drive is in status mode, status messages are generated automatically from within the adjustable frequency drive and appear in the bottom line of the display (see *Figure 7.1.*)

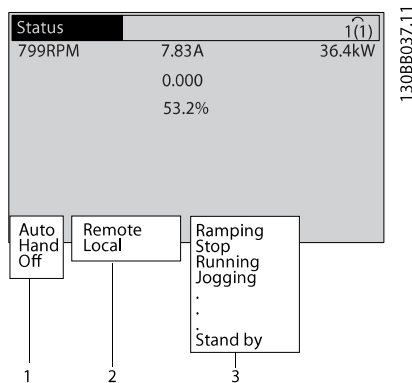

Figure 7.1 Status Display

- The first part of the status line indicates where the stop/start command originates.
- The second part of the status line indicates where the speed control originates.
- The last part of the status line gives the present adjustable frequency drive status. These show the operational mode the adjustable frequency drive is in.

NOTE!

In auto/remote mode, the adjustable frequency drive requires external commands to execute functions.

7.2 Status Message Definitions

Table 7.1 to Table 7.3 define the meaning of the displayed status messages.

Off	The frequency converter does not react to any control signal until [Auto On] or [Hand On] is pressed.
Auto On	The frequency converter is controlled from the control terminals and/or the serial communication.
Hand On	The frequency converter can be controlled by the navigation keys on the LCP. Stop commands, reset, reversing, DC brake, and other signals applied to the control terminals can override local control.

Table 7.1 Operation Mode

Remote	The speed reference is given from external signals, serial communication, or internal preset references.
Local	The frequency converter uses [Hand On] control or reference values from the LCP.

Table 7.2 Reference Site

AC Brake	AC Brake was selected in 2-10 Brake Function. The AC brake over-magnetizes the motor to achieve a controlled slow down.
AMA finish OK	Automatic motor adaptation (AMA) was carried out successfully.
AMA ready	AMA is ready to start. Press [Hand On] to start.
AMA running	AMA process is in progress.
Braking	The brake chopper is in operation. Generative energy is absorbed by the brake resistor.
Braking max.	The brake chopper is in operation. The power limit for the brake resistor defined in 2-12 Brake Power Limit (kW) has been reached.
Coast	<ul style="list-style-type: none"> Coast inverse was selected as a function for a digital input (parameter group 5-1* Digital Inputs). The corresponding terminal is not connected. Coast activated by serial communication

Ctrl. Ramp-down	Control Ramp-down was selected in <i>14-10 Line Failure</i> . <ul style="list-style-type: none"> The mains voltage is below the value set in <i>14-11 Line Voltage at Line Fault</i> at mains fault The frequency converter ramps down the motor using a controlled ramp down
Current High	The frequency converter output current is above the limit set in <i>4-51 Warning Current High</i> .
Current Low	The frequency converter output current is below the limit set in <i>4-52 Warning Speed Low</i>
DC Hold	DC hold is selected in <i>1-80 Function at Stop</i> and a stop command is active. The motor is held by a DC current set in <i>2-00 DC Hold/Preheat Current</i> .
DC Stop	The motor is held with a DC current (<i>2-01 DC Brake Current</i>) for a specified time (<i>2-02 DC Braking Time</i>). <ul style="list-style-type: none"> DC Brake is activated in <i>2-03 DC Brake Cut-in Speed [RPM]</i> and a Stop command is active. DC Brake (inverse) is selected as a function for a digital input (parameter group <i>5-1* Digital Inputs</i>). The corresponding terminal is not active. The DC Brake is activated via serial communication.
Feedback high	The sum of all active feedbacks is above the feedback limit set in <i>4-57 Warning Feedback High</i> .
Feedback low	The sum of all active feedbacks is below the feedback limit set in <i>4-56 Warning Feedback Low</i> .
Freeze output	The remote reference is active, which holds the present speed. <ul style="list-style-type: none"> Freeze output was selected as a function for a digital input (parameter group <i>5-1* Digital Inputs</i>). The corresponding terminal is active. Speed control is only possible via the terminal functions Speed Up and Speed Down. Hold ramp is activated via serial communication.
Freeze output request	A freeze output command has been given, but the motor will remain stopped until a run permissive signal is received.

Freeze ref.	<i>Freeze Reference</i> was chosen as a function for a digital input (parameter group <i>5-1* Digital Inputs</i>). The corresponding terminal is active. The frequency converter saves the actual reference. Changing the reference is now only possible via terminal functions Speed Up and Speed Down.
Jog request	A jog command has been given, but the motor will be stopped until a run permissive signal is received via a digital input.
Jogging	The motor is running as programmed in <i>3-19 Jog Speed [RPM]</i> . <ul style="list-style-type: none"> <i>Jog</i> was selected as function for a digital input (parameter group <i>5-1* Digital Inputs</i>). The corresponding terminal (e.g. Terminal 29) is active. The Jog function is activated via the serial communication. The Jog function was selected as a reaction for a monitoring function (e.g. No signal). The monitoring function is active.
Motor check	In <i>1-80 Function at Stop</i> , <i>Motor Check</i> was selected. A stop command is active. To ensure that a motor is connected to the frequency converter, a permanent test current is applied to the motor.
OVC control	<i>Overvoltage control</i> was activated in <i>2-17 Overvoltage Control, [2] Enabled</i> . The connected motor is supplying the frequency converter with generative energy. The overvoltage control adjusts the V/Hz ratio to run the motor in controlled mode and to prevent the frequency converter from tripping.
PowerUnit Off	(For frequency converters with an external 24 V power supply installed only.) Mains supply to the frequency converter is removed, but the control card is supplied by the external 24 V.
Protection md	Protection mode is active. The unit has detected a critical status (an overcurrent or overvoltage). <ul style="list-style-type: none"> To avoid tripping, switching frequency is reduced to 4 kHz. If possible, protection mode ends after approximately 10 s Protection mode can be restricted in <i>14-26 Trip Delay at Inverter Fault</i>

QStop	<p>The motor is decelerating using 3-81 <i>Quick Stop Ramp Time</i>.</p> <ul style="list-style-type: none"> • <i>Quick stop inverse</i> was chosen as a function for a digital input (parameter group 5-1* <i>Digital Inputs</i>). The corresponding terminal is not active. • The quick stop function was activated via serial communication.
Ramping	The motor is accelerating/decelerating using the active Ramp Up/Down. The reference, a limit value or a standstill is not yet reached.
Ref. high	The sum of all active references is above the reference limit set in 4-55 <i>Warning Reference High</i> .
Ref. low	The sum of all active references is below the reference limit set in 4-54 <i>Warning Reference Low</i> .
Run on ref.	The frequency converter is running in the reference range. The feedback value matches the setpoint value.
Run request	A start command has been given, but the motor is stopped until a run permissive signal is received via digital input.
Running	The motor is driven by the frequency converter.
Sleep Mode	The energy saving function is enabled. This means that at present the motor has stopped, but that it will restart automatically when required.
Speed high	Motor speed is above the value set in 4-53 <i>Warning Speed High</i> .
Speed low	Motor speed is below the value set in 4-52 <i>Warning Speed Low</i> .
Standby	In Auto On mode, the frequency converter will start the motor with a start signal from a digital input or serial communication.
Start delay	In 1-71 <i>Start Delay</i> , a delay starting time was set. A start command is activated and the motor will start after the start delay time expires.
Start fwd/rev	Start forward and start reverse were selected as functions for two different digital inputs (parameter group 5-1* <i>Digital Inputs</i>). The motor will start in forward or reverse depending on which corresponding terminal is activated.
Stop	The frequency converter has received a stop command from the LCP, digital input or serial communication.

Trip	An alarm occurred and the motor is stopped. Once the cause of the alarm is cleared, the frequency converter can be reset manually by pressing [Reset] or remotely by control terminals or serial communication.
Trip lock	An alarm occurred and the motor is stopped. Once the cause of the alarm is cleared, power must be cycled to the frequency converter. The frequency converter can then be reset manually by pressing [Reset] or remotely by control terminals or serial communication.

Table 7.3 Operation Status
NOTE!

In auto/remote mode, the frequency converter requires external commands to execute functions.

8 Warnings and Alarms

8.1 System Monitoring

The adjustable frequency drive monitors the condition of its input power, output, and motor factors as well as other system performance indicators. A warning or alarm may not necessarily indicate a problem internal to the adjustable frequency drive itself. In many cases, it indicates failure conditions from input voltage, motor load or temperature, external signals, or other areas monitored by the adjustable frequency drive's internal logic. Be sure to investigate those areas exterior to the adjustable frequency drive as indicated in the alarm or warning.

8.2 Warning and Alarm Types

Warnings

A warning is issued when an alarm condition is impending or when an abnormal operating condition is present and may result in the adjustable frequency drive issuing an alarm. A warning clears by itself when the abnormal condition is removed.

Alarms

Trip

An alarm is issued when the adjustable frequency drive is tripped, that is, the adjustable frequency drive suspends operation to prevent adjustable frequency drive or system damage. The motor will coast to a stop. The adjustable frequency drive logic will continue to operate and monitor the adjustable frequency drive status. After the fault condition is remedied, the adjustable frequency drive can be reset. It will then be ready to start operation again.

A trip can be reset in any of four ways

- Press [Reset] on the LCP
- Digital reset input command
- Serial communication reset input command
- Auto reset

An alarm that causes the adjustable frequency drive to trip-lock requires that input power is cycled. The motor will coast to a stop. The adjustable frequency drive logic will continue to operate and monitor the adjustable frequency drive status. Remove input power to the adjustable frequency drive and correct the cause of the fault, then restore power. This action puts the adjustable frequency drive into a trip condition as described above and may be reset in any of those four ways.

8.3 Warning and Alarm Displays

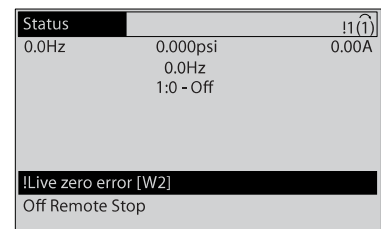

Figure 8.1 Warning Display

An alarm or trip lock alarm will flash on display along with the alarm number.

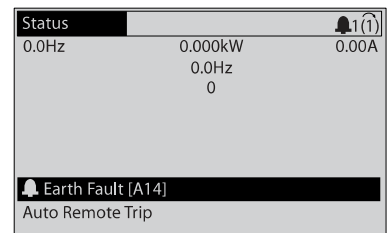

Figure 8.2 Alarm Display

In addition to the text and alarm code on the adjustable frequency drive LCP, there are three status indicator lights.

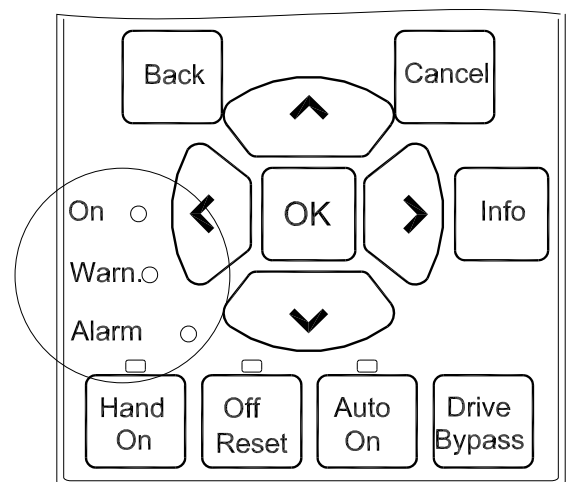

Figure 8.3 Status Indicator Lights

	Warning LED	Alarm LED
Warning	On	Off
Alarm	Off	On (Flashing)
Trip Lock	On	On (Flashing)

Table 8.1 Status Indicator Lights Explanations

8.4 Warning and Alarm Definitions

Table 8.2 defines whether a warning is issued before an alarm, and whether the alarm trips the unit or trip locks the unit.

No.	Description	Warning	Alarm/Trip	Alarm/Trip Lock	Parameter Reference
1	10 Volts low	X			
2	Live zero error	(X)	(X)		6-01 Live Zero Timeout Function
4	Mains phase loss	(X)	(X)	(X)	14-12 Function at Mains Imbalance
5	DC link voltage high	X			
6	DC link voltage low	X			
7	DC overvoltage	X	X		
8	DC undervoltage	X	X		
9	Inverter overloaded	X	X		
10	Motor ETR overtemperature	(X)	(X)		1-90 Motor Thermal Protection
11	Motor thermistor over-temp	(X)	(X)		1-90 Motor Thermal Protection
12	Torque limit	X	X		
13	Overcurrent	X	X	X	
14	Ground fault	X	X	X	
15	Hardware mismatch		X	X	
16	Short Circuit		X	X	
17	Control word timeout	(X)	(X)		8-04 Control Timeout Function
18	Start Failed		X		1-77 Compressor Start Max Speed [RPM], 1-79 Compressor Start Max Time to Trip, 1-03 Torque Characteristics
23	Internal Fan Fault	X			
24	External Fan Fault	X			14-53 Fan Monitor
25	Brake resistor short-circuited	X			
26	Brake resistor power limit	(X)	(X)		2-13 Brake Power Monitoring
27	Brake chopper short-circuited	X	X		
28	Brake check	(X)	(X)		2-15 Brake Check
29	Drive overtemperature	X	X	X	
30	Motor phase U missing	(X)	(X)	(X)	4-58 Missing Motor Phase Function
31	Motor phase V missing	(X)	(X)	(X)	4-58 Missing Motor Phase Function
32	Motor phase W missing	(X)	(X)	(X)	4-58 Missing Motor Phase Function
33	Inrush fault		X	X	
34	Fieldbus communication fault	X	X		
35	Out of frequency range	X	X		
36	Mains failure	X	X		
37	Phase Imbalance	X	X		

No.	Description	Warning	Alarm/Trip	Alarm/Trip Lock	Parameter Reference
38	Internal fault		X	X	
39	Heatsink sensor		X	X	
40	Overload of Digital Output Terminal 27	(X)			E-00 Digital I/O Mode, 5-01 Terminal 27 Mode
41	Overload of Digital Output Terminal 29	(X)			E-00 Digital I/O Mode, 5-02 Terminal 29 Mode
42	Overload of Digital Output On X30/6	(X)			5-32 Term X30/6 Digi Out (MCB 101)
42	Overload of Digital Output On X30/7	(X)			5-33 Term X30/7 Digi Out (MCB 101)
46	Pwr. card supply		X	X	
47	24 V supply low	X	X	X	
48	1.8 V supply low		X	X	
49	Speed limit	X	(X)		1-86 Trip Speed Low [RPM]
50	AMA calibration failed		X		
51	AMA check U _{nom} and I _{nom}		X		
52	AMA low I _{nom}		X		
53	AMA motor too big		X		
54	AMA motor too small		X		
55	AMA Parameter out of range		X		
56	AMA interrupted by user		X		
57	AMA timeout		X		
58	AMA internal fault	X	X		
59	Current limit	X			
60	External Interlock	X			
62	Output Frequency at Maximum Limit	X			
64	Voltage Limit	X			
65	Control Board Over temperature	X	X	X	
66	Heatsink Temperature Low	X			
67	Option Configuration has Changed		X		
69	Pwr. Card Temp		X	X	
70	Illegal FC configuration			X	
72	Dangerous Failure			X ¹⁾	
73	Safe Stop Auto Restart				
76	Power Unit Set-up	X			
77	Reduced Power Mode				
79	Illegal PS config		X	X	
80	Drive Initialized to Default Value		X		
91	Analog input 54 wrong settings			X	
92	No-Flow	X	X		22-2*
93	Dry Pump	X	X		22-2*
94	End of Curve	X	X		22-5*
95	Broken Belt	X	X		22-6*
96	Start Delayed	X			22-7*
97	Stop Delayed	X			22-7*
98	Clock Fault	X			0-7*
201	Fire M was Active				
202	Fire M Limits Exceeded				
203	Missing Motor				

No.	Description	Warning	Alarm/Trip	Alarm/Trip Lock	Parameter Reference
204	Locked Rotor				
243	Brake IGBT	X	X		
244	Heatsink temp	X	X	X	
245	Heatsink sensor		X	X	
246	Pwr.card supply		X	X	
247	Pwr.card temp		X	X	
248	Illegal PS config		X	X	
250	New spare parts			X	
251	New Type Code		X	X	

Table 8.2 Alarm/Warning Code List

(X) Dependent on parameter

¹⁾ Cannot be Auto reset via 14-20 Reset Mode

⚠ WARNING

Hazardous Service Procedures!

The maintenance and troubleshooting procedures recommended in this section of the manual could result in exposure to electrical, mechanical or other potential safety hazards. Always refer to the safety warnings provided throughout this manual concerning these procedures. Unless specified otherwise, disconnect all electrical power including remote disconnect and discharge all energy storing devices such as capacitors before servicing. Follow proper lockout/tagout procedures to ensure the power cannot be inadvertently energized. When necessary to work with live electrical components, have a qualified licensed electrician or other individual who has been trained in handling live electrical components perform these tasks. Failure to follow all of the recommended safety warnings provided could result in death or serious injury.

The warning/alarm information below defines each warning/alarm condition, provides the probable cause for the condition, and details a remedy or troubleshooting procedure.

WARNING 1, 10 Volts low

The control card voltage is below 10 V from terminal 50. Remove some of the load from terminal 50, as the 10 V supply is overloaded. Max. 15 mA or minimum 590 Ω.

This condition can be caused by a short in a connected potentiometer or improper wiring of the potentiometer.

Troubleshooting

Remove the wiring from terminal 50. If the warning clears, the problem is with the customer wiring. If the warning does not clear, replace the control card.

WARNING/ALARM 2, Live zero error

This warning or alarm only appears if programmed by the user in 6-01 *Live Zero Timeout Function*. The signal on one of the analog inputs is less than 50% of the minimum value programmed for that input. Broken wiring or faulty device sending the signal can cause this condition.

Troubleshooting

Check connections on all the analog input terminals. Control card terminals 53 and 54 for signals, terminal 55 common. MCB 101 terminals 11 and 12 for signals, terminal 10 common. MCB 109 terminals 1, 3, 5 for signals, terminals 2, 4, 6 common).

Check that the adjustable frequency drive programming and switch settings match the analog signal type.

Perform Input Terminal Signal Test.

WARNING/ALARM 4, Mains phase loss

A phase is missing on the supply side, or the line voltage imbalance is too high. This message also appears for a fault in the input rectifier on the adjustable frequency drive. Options are programmed at 14-12 *Function at Mains Imbalance*.

Troubleshooting

Check the supply voltage and supply currents to the adjustable frequency drive.

WARNING 5, DC link voltage high

The intermediate circuit voltage (DC) is higher than the high voltage warning limit. The limit is dependent on the adjustable frequency drive voltage rating. The unit is still active.

WARNING 6, DC link voltage low

The intermediate circuit voltage (DC) is lower than the low voltage warning limit. The limit is dependent on the adjustable frequency drive voltage rating. The unit is still active.

WARNING/ALARM 7, DC overvoltage

If the intermediate circuit voltage exceeds the limit, the adjustable frequency drive trips after a time.

Troubleshooting

- Connect a brake resistor
- Extend the ramp time
- Change the ramp type
- Activate the functions in *2-10 Brake Function*
- Increase *14-26 Trip Delay at Inverter Fault*
- If the alarm/warning occurs during a power sag, the solution is to use kinetic backup (*14-10 Line Failure*)

WARNING/ALARM 8, DC undervoltage

If the intermediate circuit voltage (DC link) drops below the undervoltage limit, the adjustable frequency drive checks if a 24 V DC backup supply is connected. If no 24 V DC backup supply is connected, the adjustable frequency drive trips after a fixed time delay. The time delay varies with unit size.

Troubleshooting

- Make sure that the supply voltage matches the adjustable frequency drive voltage.
- Perform input voltage test.
- Perform soft charge circuit test.

WARNING/ALARM 9, Inverter overload

The adjustable frequency drive is about to cut out because of an overload (current too high for too long). The counter for electronic, thermal inverter protection issues a warning at 98% and trips at 100%, while giving an alarm. The adjustable frequency drive *cannot* be reset until the counter is below 90%.

The fault is that the adjustable frequency drive has run with more than 100% overload for too long.

Troubleshooting

- Compare the output current shown on the LCP with the adjustable frequency drive rated current.
- Compare the output current shown on the LCP with measured motor current.
- Display the Thermal Drive Load on the LCP and monitor the value. When running above the adjustable frequency drive continuous current rating, the counter increases. When running

below the adjustable frequency drive continuous current rating, the counter decreases.

WARNING/ALARM 10, Motor overload temperature

According to the electronic thermal protection (ETR), the motor is too hot. Select whether the adjustable frequency drive issues a warning or an alarm when the counter reaches 100% in *1-90 Motor Thermal Protection*. The fault occurs when the motor runs with more than 100% overload for too long.

Troubleshooting

- Check for motor overheating.
- Check if the motor is mechanically overloaded.
- Check that the motor current set in *1-24 Motor Current* is correct.
- Ensure that motor data in parameters 1-20 through 1-25 are set correctly.
- If an external fan is in use, check in *1-91 Motor External Fan* that it is selected.
- Running AMA in *1-29 Automatic Motor Adaptation (AMA)* tunes the adjustable frequency drive to the motor more accurately and reduces thermal loading.

WARNING/ALARM 11, Motor thermistor overtemp

Check whether the thermistor is disconnected. Select whether the adjustable frequency drive issues a warning or an alarm in *1-90 Motor Thermal Protection*.

WARNING

Live Electrical Components!

Troubleshooting

- Check for motor overheating.
- Check if the motor is mechanically overloaded.
- When using terminal 53 or 54, check that the thermistor is connected correctly between either terminal 53 or 54 (analog voltage input) and terminal 50 (+10 V supply). Also check that the terminal switch for 53 or 54 is set for voltage. Check *1-93 Thermistor Source* selects terminal 53 or 54.
- When using digital inputs 18 or 19, check that the thermistor is connected correctly between either terminal 18 or 19 (digital input PNP only) and terminal 50. Check *1-93 Thermistor Source* selects terminal 18 or 19.

WARNING

Disconnect power before proceeding.

WARNING/ALARM 12, Torque limit

The torque has exceeded the value in *4-16 Torque Limit Motor Mode* or the value in *4-17 Torque Limit Generator Mode*. *14-25 Trip Delay at Torque Limit* can change this from a warning only condition to a warning followed by an alarm.

Troubleshooting

If the motor torque limit is exceeded during ramp-up, extend the ramp-up time.

If the generator torque limit is exceeded during ramp-down, extend the ramp-down time.

If torque limit occurs while running, possibly increase the torque limit. Make sure that the system can operate safely at a higher torque.

Check the application for excessive current draw on the motor.

WARNING/ALARM 13, Overcurrent

The inverter peak current limit (approximately 200% of the rated current) is exceeded. The warning lasts about 1.5 s, then the adjustable frequency drive trips and issues an alarm. This fault can be caused by shock loading or quick acceleration with high inertia loads. It can also appear after kinetic backup if the acceleration during ramp-up is quick. If extended mechanical brake control is selected, trip can be reset externally.

Troubleshooting

Remove power and check if the motor shaft can be turned.

Make sure that the motor size matches the adjustable frequency drive.

Check parameters 1-20 to 1-25 for correct motor data.

ALARM 14, Ground fault

There is current from the output phases to ground, either in the cable between the adjustable frequency drive and the motor or in the motor itself.

Troubleshooting:

Remove power to the adjustable frequency drive and repair the ground fault.

Check for ground faults in the motor by measuring the resistance to ground of the motor leads and the motor with a megohmmeter.



Disconnect power before proceeding.

ALARM 15, Hardware mismatch

A fitted option is not operational with the present control board hardware or software.

Record the value of the following parameters and contact your Trane supplier:

15-40 FC Type

15-41 Power Section

15-42 Voltage

15-43 Software Version

15-45 Actual Typecode String

15-49 SW ID Control Card

15-50 SW ID Power Card

15-60 Option Mounted

15-61 Option SW Version (for each option slot)

ALARM 16, Short-circuit

There is short-circuiting in the motor or motor wiring.

Remove power to the adjustable frequency drive and repair the short circuit.



Disconnect power before proceeding.

WARNING/ALARM 17, Control word timeout

There is no communication to the adjustable frequency drive.

The warning is only active when *8-04 Control Timeout Function* is NOT set to [0] Off.

If *8-04 Control Timeout Function* is set to [5] Stop and Trip, a warning appears and the adjustable frequency drive ramps down until it stops then displays an alarm.



Live Electrical Components!

Troubleshooting:

Check connections on the serial communication cable.

Increase *8-03 Control Timeout Time*

Check the operation of the communication equipment.

Verify a proper installation based on EMC requirements.

ALARM 18, Start failed

The speed has not been able to exceed *AP-70 Compressor Start Max Speed [RPM]* during start within the allowed time. (set in *AP-72 Compressor Start Max Time to Trip*). This may be caused by a blocked motor.

WARNING 23, Internal fan fault

The fan warning function is an extra protective function that checks if the fan is running/mounted. The fan warning can be disabled in *14-53 Fan Monitor ([0] Disabled)*.

For the D, E, and F Frame filters, the regulated voltage to the fans is monitored.

Troubleshooting

Check for proper fan operation.

Cycle power to the adjustable frequency drive and check that the fan operates briefly at start-up.

Check the sensors on the heatsink and control card.

WARNING 24, External fan fault

The fan warning function is an extra protective function that checks if the fan is running/mounted. The fan warning can be disabled in *14-53 Fan Monitor ([0] Disabled)*.

Troubleshooting

Check for proper fan operation.

Cycle power to the adjustable frequency drive and check that the fan operates briefly at start-up.

Check the sensors on the heatsink and control card.

WARNING/ALARM 28, Brake check failed

The brake resistor is not connected or not working. Check *2-15 Brake Check*.

ALARM 29, Heatsink temp

The maximum temperature of the heatsink has been exceeded. The temperature fault will not reset until the temperature falls below a defined heatsink temperature. The trip and reset points are different based on the adjustable frequency drive power size.

Troubleshooting

Check for the following conditions.

Ambient temperature too high.

Motor cable too long.

Incorrect airflow clearance above and below the adjustable frequency drive.

Blocked airflow around the adjustable frequency drive.

Damaged heatsink fan.

Dirty heatsink.

ALARM 30, Motor phase U missing

Motor phase U between the adjustable frequency drive and the motor is missing.

WARNING

Disconnect power before proceeding.

Remove power from the adjustable frequency drive and check motor phase U.

ALARM 31, Motor phase V missing

Motor phase V between the adjustable frequency drive and the motor is missing.

WARNING

Disconnect power before proceeding.

Remove power from the adjustable frequency drive and check motor phase V.

ALARM 32, Motor phase W missing

Motor phase W between the adjustable frequency drive and the motor is missing.

WARNING

Disconnect power before proceeding.

Remove power from the adjustable frequency drive and check motor phase W.

ALARM 33, Inrush fault

Too many power-ups have occurred within a short time period. Let the unit cool to operating temperature.

WARNING/ALARM 34, Fieldbus communication fault

The serial communication bus on the communication option card is not working.

WARNING/ALARM 36, Mains Failure

This warning/alarm is only active if the supply voltage to the adjustable frequency drive is lost and *14-10 Line Failure* is NOT set to *[0] No Function*. Check the fuses to the adjustable frequency drive and line power supply to the unit.

ALARM 38, Internal fault

When an internal fault occurs, a code number defined in *Table 8.3* is displayed.

Troubleshooting

Cycle power

Check that the option is properly installed

Check for loose or missing wiring

It may be necessary to contact your Trane supplier or service department. Note the code number for further troubleshooting directions.

No.	Text
0	Serial port cannot be initialized. Contact your Trane supplier or Trane Service Department.
256-258	Power EEPROM data is defective or too old. Replace power card.
512-519	Internal fault. Contact your Trane supplier or Trane Service Department.
783	Parameter value outside of min/max limits
1024-1284	Internal fault. Contact your Trane supplier or the Trane Service Department.
1299	Option SW in slot A is too old
1300	Option SW in slot B is too old
1315	Option SW in slot A is not supported (not allowed)
1316	Option SW in slot B is not supported (not allowed)
1379-2819	Internal fault. Contact your Trane supplier or Trane Service Department.
2561	Replace control card
2820	LCP stack overflow
2821	Serial port overflow
2822	USB port overflow
3072-5122	Parameter value is outside its limits
5123	Option in slot A: Hardware incompatible with control board hardware
5124	Option in slot B: Hardware incompatible with control board hardware
5376-6231	Internal fault. Contact your Trane supplier or Trane Service Department.

Table 8.3 Internal Fault Codes

ALARM 39, Heatsink sensor

No feedback from the heatsink temperature sensor.

The signal from the IGBT thermal sensor is not available on the power card. The problem could be on the power card, on the gate drive card, or the ribbon cable between the power card and gate drive card.

WARNING 40, Overload of digital output terminal 27

Check the load connected to terminal 27 or remove short-circuit connection. Check *5-01 Terminal 27 Mode*.

WARNING 41, Overload of digital output terminal 29

Check the load connected to terminal 29 or remove short-circuit connection. Check *5-02 Terminal 29 Mode*.

WARNING 42, Overload of digital output on X30/6 or overload of digital output on X30/7

For X30/6, check the load connected to X30/6 or remove the short-circuit connection. Check *5-32 Term X30/6 Digi Out (MCB 101)*.

For X30/7, check the load connected to X30/7 or remove the short-circuit connection. Check *5-33 Term X30/7 Digi Out (MCB 101)*.

ALARM 45, Ground fault 2

Ground fault on start-up.

Troubleshooting

Check for proper grounding and loose connections.

Check for proper wire size.

Check motor cables for short-circuits or leakage currents.

ALARM 46, Power card supply

The supply on the power card is out of range.

There are three power supplies generated by the switch mode power supply (SMPS) on the power card: 24 V, 5 V, ±18 V. When powered with 24 V DC with the MCB 107 option, only the 24 V and 5 V supplies are monitored. When powered with three phase AC line voltage, all three supplies are monitored.

Troubleshooting

Check for a defective power card.

Check for a defective control card.

Check for a defective option card.

If a 24 V DC power supply is used, verify proper supply power.

WARNING 47, 24 V supply low

The 24 Vdc is measured on the control card.

WARNING 48, 1.8 V supply low

The 1.8 VDC supply used on the control card is outside of allowable limits. The power supply is measured on the control card. Check for a defective control card. If an option card is present, check for an overvoltage condition.

WARNING 49, Speed limit

When the speed is not within the specified range in *4-11 Motor Speed Low Limit [RPM]* and *4-13 Motor Speed High Limit [RPM]*, the adjustable frequency drive shows a warning. When the speed is below the specified limit in *1-86 Trip Speed Low [RPM]* (except when starting or stopping), the adjustable frequency drive will trip.

ALARM 50, AMA calibration failed

Contact your Trane supplier or Trane Service Department.

ALARM 51, AMA check U_{nom} and I_{nom}

The settings for motor voltage, motor current and motor power are wrong. Check the settings in parameters 1-20 to 1-25.

ALARM 52, AMA low I_{nom}

The motor current is too low. Check the settings.

ALARM 53, AMA motor too big

The motor is too big for the AMA to operate.

ALARM 54, AMA motor too small

The motor is too small for the AMA to operate.

ALARM 55, AMA Parameter out of range

The parameter values of the motor are outside of the acceptable range. AMA will not run.

ALARM 56, AMA interrupted by user

The user has interrupted the AMA.

ALARM 57, AMA internal fault

Try to restart AMA again. Repeated restarts can overheat the motor.

ALARM 58, AMA internal fault

Contact your Trane supplier.

WARNING 59, Current limit

The current is higher than the value in *4-18 Current Limit*. Ensure that Motor data in parameters 1-20 to 1-25 are set correctly. Possibly increase the current limit. Be sure that the system can operate safely at a higher limit.

WARNING 60, External interlock

A digital input signal is indicating a fault condition external to the adjustable frequency drive. An external interlock has commanded the adjustable frequency drive to trip. Clear the external fault condition. To resume normal operation, apply 24 Vdc to the terminal programmed for external interlock. Reset the adjustable frequency drive.

WARNING 62, Output frequency at maximum limit

The output frequency has reached the value set in *4-19 Max Output Frequency*. Check the application to determine the cause. Possibly increase the output frequency limit. Be sure the system can operate safely at a higher output frequency. The warning will clear when the output drops below the maximum limit.

WARNING/ALARM 65, Control card over temperature

The cutout temperature of the control card is 176° F [80°C].

Troubleshooting

- Check that the ambient operating temperature is within limits.
- Check for clogged filters.
- Check fan operation.
- Check the control card.

WARNING 66, Heatsink temperature low

The adjustable frequency drive is too cold to operate. This warning is based on the temperature sensor in the IGBT module.

Increase the ambient temperature of the unit. Also, a trickle amount of current can be supplied to the adjustable frequency drive whenever the motor is stopped by setting *2-00 DC Hold/Preheat Current* at 5% and *1-80 Function at Stop*

ALARM 67, Option module configuration has changed

One or more options have either been added or removed since the last power-down. Check that the configuration change is intentional and reset the unit.

ALARM 69, Power card temperature

The temperature sensor on the power card is either too hot or too cold.

Troubleshooting

- Check that the ambient operating temperature is within limits.
- Check for clogged filters.
- Check fan operation.
- Check the power card.

ALARM 70, Illegal adjustable frequency drive configuration

The control card and power card are incompatible. Contact your supplier with the type code of the unit from the nameplate and the part numbers of the cards to check compatibility.

ALARM 80, Drive initialized to default value

Parameter settings are initialized to default settings after a manual reset. Reset the unit to clear the alarm.

ALARM 92, No-Flow

A no-flow condition has been detected in the system. *22-23 No-Flow Function* is set for alarm. Troubleshoot the system and reset the adjustable frequency drive after the fault has been cleared.

ALARM 93, Dry pump

A no-flow condition in the system with the adjustable frequency drive operating at high speed may indicate a dry pump. *22-26 Dry Pump Function* is set for alarm. Troubleshoot the system and reset the adjustable frequency drive after the fault has been cleared.

ALARM 94, End of curve

Feedback is lower than the setpoint. This may indicate leakage in the system. *22-50 End of Curve Function* is set for alarm. Troubleshoot the system and reset the adjustable frequency drive after the fault has been cleared.

ALARM 95, Broken belt

Torque is below the torque level set for no load, indicating a broken belt. *22-60 Broken Belt Function* is set for alarm. Troubleshoot the system and reset the adjustable frequency drive after the fault has been cleared.

ALARM 96, Start delayed

Motor start has been delayed due to short-cycle protection. *22-76 Interval between Starts* is enabled. Troubleshoot the system and reset the adjustable frequency drive after the fault has been cleared.

WARNING 97, Stop delayed

Stopping the motor has been delayed due to short cycle protection. *22-76 Interval between Starts* is enabled. Troubleshoot the system and reset the adjustable frequency drive after the fault has been cleared.

WARNING 98, Clock fault

Time is not set or the RTC clock has failed. Reset the clock in *0-70 Date and Time*.

WARNING 200, Fire mode

This warning indicates the adjustable frequency drive is operating in Fire mode. The warning clears when fire mode is removed. See the fire mode data in the alarm log.

WARNING 201, Fire Mode was Active

This indicates the adjustable frequency drive had entered fire mode. Cycle power to the unit to remove the warning. See the fire mode data in the alarm log.

WARNING 202, Fire mode limits exceeded

While operating in fire mode one or more alarm conditions have been ignored which would normally trip the unit. Operating in this condition voids unit warranty. Cycle power to the unit to remove the warning. See the fire mode data in the alarm log.

WARNING 203, Missing motor

With an adjustable frequency drive operating multi-motors, an underload condition was detected. This could indicate a missing motor. Inspect the system for proper operation.

WARNING 204, Locked rotor

With an adjustable frequency drive operating multi-motors, an overload condition was detected. This could indicate a locked rotor. Inspect the motor for proper operation.

WARNING 250, New spare part

A component in the adjustable frequency drive has been replaced. Reset the adjustable frequency drive for normal operation.

WARNING 251, New type code

The power card or other components have been replaced and the type code changed. Reset to remove the warning and resume normal operation.

9 Basic Troubleshooting

9.1 Start-up and Operation

Symptom	Possible cause	Test	Solution
Display dark/No function	Missing input power	See <i>Table 3.1</i>	Check the input power source
	Missing or open fuses or circuit breaker tripped	See open fuses and tripped circuit breaker in this table for possible causes.	Follow the recommendations provided.
	No power to the LCP	Check the LCP cable for proper connection or damage.	Replace the faulty LCP or connection cable.
	Shortcut on control voltage (terminal 12 or 50) or at control terminals	Check the 24 V control voltage supply for terminals 12/13 to 20-39 or 10 V supply for terminals 50 to 55.	Wire the terminals properly.
	Wrong LCP (LCP from VLT® 2800 or 5000/6000/8000/ FCD or FCM)		Use only LCP 101 (P/N 130B1124) or LCP 102 (P/N 130B1107).
	Wrong contrast setting		Press [Status] + [▲]/[▼] to adjust the contrast
	Display (LCP) is defective	Test using a different LCP	Replace the faulty LCP or connection cable.
	Internal voltage supply fault or SMPS is defective		Contact supplier
Intermittent display	Overloaded power supply (SMPS) due to improper control wiring or a fault within the adjustable frequency drive	To rule out a problem in the control wiring, disconnect all control wiring by removing the terminal blocks.	If the display stays lit, then the problem is in the control wiring. Check the wiring for shorts or incorrect connections. If the display continues to cut out, follow the procedure for display dark.

Symptom	Possible cause	Test	Solution
Motor not running	Service switch open or missing motor connection	Check if the motor is connected and the connection is not interrupted (by a service switch or other device).	Connect the motor and check the service switch.
	No line power with 24 V DC option card	If the display is functioning but no output, check that line power is applied to the adjustable frequency drive.	Apply line power to run the unit.
	LCP Stop	Check if [Off] has been pressed.	Press [Auto On] or [Hand On] (depending on operation mode) to run the motor.
	Missing start signal (Standby)	Check 5-10 <i>Terminal 18 Digital Input</i> for correct setting for terminal 18 (use default setting)	Apply a valid start signal to start the motor.
	Motor coast signal active (Coasting)	Check 5-12 <i>Coast inv.</i> for correct setting for terminal 27 (use default setting).	Apply 24 V on terminal 27 or program this terminal to No operation.
	Wrong reference signal source	Check reference signal: Local, remote or bus reference? Preset reference active? Terminal connection correct? Scaling of terminals correct? Reference signal available?	Program correct settings. Check 3-13 <i>Reference Site</i> . Set preset reference active in parameter group 3-1* <i>References</i> . Check for correct wiring. Check scaling of terminals. Check reference signal.
Motor running in wrong direction	Motor rotation limit	Check that 4-10 <i>Motor Speed Direction</i> is programmed correctly.	Program correct settings.
	Active reversing signal	Check if a reversing command is programmed for the terminal in parameter group 5-1* <i>Digital inputs</i> .	Deactivate reversing signal.
	Wrong motor phase connection		See 3.7 <i>Check Motor Rotation</i> in this manual
Motor is not reaching maximum speed	Frequency limits set wrong	Check output limits in 4-13 <i>Motor Speed High Limit [RPM]</i> , 4-14 <i>Motor Speed High Limit [Hz]</i> and 4-19 <i>Max Output Frequency</i> .	Program correct limits.
	Reference input signal not scaled correctly	Check reference input signal scaling in 6-0* <i>Analog I/O Mode</i> and parameter group 3-1* <i>References</i> . Reference limits in parameter group 3-0* <i>Reference Limit</i> .	Program correct settings.
Motor speed unstable	Possible incorrect parameter settings	Check the settings of all motor parameters, including all motor compensation settings. For closed-loop operation, check PID settings.	Check settings in parameter group 1-6* <i>Analog I/O mode</i> . For closed-loop operation, check settings in parameter group 20-0* <i>Feedback</i> .
Motor runs rough	Possible over-magnetization	Check for incorrect motor settings in all motor parameters.	Check motor settings in parameter groups 1-2* <i>Motor Data</i> , 1-3* <i>Adv Motor Data</i> , and 1-5* <i>Load Indep. Setting</i> .
Motor will not brake.	Possible incorrect settings in the brake parameters. Possible too short ramp down times.	Check brake parameters. Check ramp time settings.	Check parameter group 2-0* <i>DC Brake</i> and 3-0* <i>Reference Limits</i> .

Symptom	Possible cause	Test	Solution
Open power fuses or circuit breaker trip.	Phase to phase short	Motor or panel has a short phase to phase. Check motor and panel phase for shorts.	Eliminate any shorts detected.
	Motor overload	Motor is overloaded for the application.	Perform start-up test and verify motor current is within specifications. If motor current is exceeding nameplate full load current, motor may run only with reduced load. Review the specifications for the application.
	Loose connections	Perform pre-startup check for loose connections.	Tighten loose connections.
Line power current imbalance greater than 3%	Problem with line power (See <i>Alarm 4 Line phase loss</i> description).	Rotate input power leads into the adjustable frequency drive one position: A to B, B to C, C to A.	If imbalanced leg follows the wire, it is a power problem. Check line power supply.
	Problem with the adjustable frequency drive	Rotate input power leads into the adjustable frequency drive one position: A to B, B to C, C to A.	If imbalance leg stays on same input terminal, it is a problem with the unit. Contact the supplier.
Motor current imbalance greater than 3%	Problem with motor or motor wiring	Rotate output motor leads one position: U to V, V to W, W to U.	If imbalanced leg follows the wire, the problem is in the motor or motor wiring. Check motor and motor wiring.
	Problem with the adjustable frequency drives	Rotate output motor leads one position: U to V, V to W, W to U.	If imbalance leg stays on same output terminal, it is a problem with the unit. Contact the supplier.
Acoustic noise or vibration (e.g., a fan blade is making noise or vibrations at certain frequencies)	Resonances, e.g., in the motor/fan system	Bypass critical frequencies by using parameters in parameter group 4-6* Speed Bypass.	Check if noise and/or vibration have been reduced to an acceptable limit.
		Turn off over-modulation in 14-03 <i>Overmodulation</i>	
		Change switching pattern and frequency in parameter group 14-0* Inverter Switching.	
		Increase Resonance Dampening in 1-64 <i>Resonance Dampening</i>	

Table 9.1 Troubleshooting

10 Specifications

10.1 Power-dependent Specifications

Adjustable frequency drive Typical Shaft Output [kW]	P1K1 1.1	P1K5 1.5	P2K2 2.2	P3K0 3	P3K7 3.7
Line Power Supply 200–240 V AC - Normal overload 110% for 1 minute					
IP20/Chassis ⁵⁾	A2	A2	A2	A3	A3
IP55/Type 12	A4/A5	A4/A5	A4/A5	A5	A5
IP66/NEMA 4X	A4/A5	A4/A5	A4/A5	A5	A5
Typical Shaft Output [HP] at 208 V	1.5	2.0	2.9	4.0	4.9
Output current					
Continuous (3 x 200–240 V) [A]	6.6	7.5	10.6	12.5	16.7
Intermittent (3 x 200–240 V) [A]	7.3	8.3	11.7	13.8	18.4
Continuous kVA (208 V AC) [kVA]	2.38	2.70	3.82	4.50	6.00
Max. input current					
Continuous (3 x 200–240 V) [A]	5.9	6.8	9.5	11.3	15.0
Intermittent (3 x 200–240 V) [A]	6.5	7.5	10.5	12.4	16.5
Additional specifications					
Estimated power loss at rated max. load [W] ⁴⁾	63	82	116	155	185
IP20, IP21 max. cable cross-section (line power, motor, brake and load sharing) [mm ² / (AWG)]	4, 4, 4 (12, 12, 12) (min. 0.2 (24))				
IP55, IP66 max. cable cross-section (line power, motor, brake and load sharing) [mm ² / (AWG)]	4, 4, 4 (12, 12, 12)				
Max. cable cross-section with disconnect	6, 4, 4 (10, 12, 12)				
Weight enclosure IP20 lb [kg]	10.8 [4.9]	10.8 [4.9]	10.8 [4.9]	14.55 [6.6]	14.55 [6.6]
Weight enclosure IP21 lb [kg]	12.13 [5.5]	12.13 [5.5]	12.13 [5.5]	16.54 [7.5]	16.54 [7.5]
Weight enclosure IP55 lb [kg] (A4/A5)	21.39/2 9.76 [9.7/13.5]	21.39/2 9.76 [9.7/13.5]	21.39/2 9.76 [9.7/13.5]	29.76 [13.5]	29.76 [13.5]
Weight enclosure IP66 lb [kg] (A4/A5)	21.39/2 9.76 [9.7/13.5]	21.39/2 9.76 [9.7/13.5]	21.39/2 9.76 [9.7/13.5]	29.76 [13.5]	29.76 [13.5]
Efficiency ³⁾	0.96	0.96	0.96	0.96	0.96

Table 10.1 Line Power Supply 200–240 V AC

Adjustable frequency drive Typical Shaft Output [kW]	P1K1 1.1	P1K5 1.5	P2K2 2.2	P3K0 3	P3K7 3.7
Line Power Supply 3x200–240 V AC - Normal overload 110% for 1 minute					
IP20/Chassis ⁶⁾	B3	B3	B3	B4	B4
IP21/NEMA 1	B1	B1	B1	B2	C1
IP55/Type 12	B1	B1	B1	B2	C1
IP66/NEMA 4X	B1	B1	B1	B2	C1
Adjustable frequency drive Typical Shaft Output [kW]	P5K5 5.5	P7K5 7.5	P11K 11	P15K 15	P18K 18.5
Typical Shaft Output [HP] at 208 V	7.5	10	15	20	25
Output current					
Continuous (3 x 200–240 V) [A]	24.2	30.8	46.2	59.4	74.8
Intermittent (3 x 200–240 V) [A]	26.6	33.9	50.8	65.3	82.3
Continuous kVA (208 V AC) [kVA]	8.7	11.1	16.6	21.4	26.9
Max. input current					
Continuous (3 x 200–240 V) [A]	22.0	28.0	42.0	54.0	68.0
Intermittent (3 x 200–240 V) [A]	24.2	30.8	46.2	59.4	74.8
Additional Specifications					
Estimated power loss at rated max. load [W] ⁴⁾	269	310	447	602	737
IP20 max. cable cross-section (line power, brake, motor and load sharing)	10, 10 (8,8-)		35,-,- (2,-,-)	35 (2)	50 (1)
IP21, IP55, IP66 max. cable cross-section (line power, motor) [mm ² /AWG]	10, 10 (8,8-)		35, 25, 25 (2, 4, 4)	50 (1)	
IP21, IP55, IP66 max. cable cross-section (brake, load sharing) [mm ² /AWG]	16, 10, 16 (6, 8, 6)		35,-,- (2,-,-)	50 (1)	
Weight enclosure IP20 lb [kg]	26.46 [12]	26.46 [12]	26.46 [12]	51.81 [23.5]	51.81 [23.5]
Weight enclosure IP21 lb [kg]	50.71 [23]	50.71 [23]	50.71 [23]	59.53 [27]	99.21 [45]
Weight enclosure IP55 lb [kg]	50.71 [23]	50.71 [23]	50.71 [23]	59.53 [27]	99.21 [45]
Weight enclosure IP66 lb [kg]	50.71 [23]	50.71 [23]	50.71 [23]	59.53 [27]	99.21 [45]
Efficiency ³⁾	0.96	0.96	0.96	0.96	0.96

Table 10.2 Line Power Supply 3x200–240 V AC

Adjustable frequency drive Typical Shaft Output [kW]	P1K1 1.1	P1K5 1.5	P2K2 2.2	P3K0 3
Line Power Supply 3x200–240 V AC - Normal overload 110% for 1 minute				
IP20/Chassis ⁶⁾	C3	C3	C4	C4
IP21/NEMA 1	C1	C1	C2	C2
IP55/Type 12	C1	C1	C2	C2
IP66/NEMA 4X	C1	C1	C2	C2
Adjustable frequency drive Typical Shaft Output [kW]	P22K 22	P30K 30	P37K 37	P45K 45
Typical Shaft Output [HP] at 208 V	30	40	50	60
Output current				
Continuous (3 x 200–240 V) [A]	88.0	115	143	170
Intermittent (3 x 200–240 V) [A]	96.8	127	157	187
Continuous kVA (208 V AC) [kVA]	31.7	41.4	51.5	61.2
Max. input current				
Continuous (3 x 200–240 V) [A]	80.0	104.0	130.0	154.0
Intermittent (3 x 200–240 V) [A]	88.0	114.0	143.0	169.0
Additional Specifications				
Estimated power loss at rated max. load [W] ⁴⁾	845	1140	1353	1636
IP20 max. cable cross-section (line power, brake, motor and load sharing)	150 (300 MCM)			
IP21, IP55, IP66 max. cable cross-section (line power, motor) [mm ² /AWG]	150 (300 MCM)			
IP21, IP55, IP66 max. cable cross-section (brake, load sharing) [mm ² /AWG]	95 (3/0)			
Weight enclosure IP20 lb [kg]	77.16 [35]	77.16 [35]	110.23 [50]	110.23 [50]
Weight enclosure IP21 lb [kg]	99.21 [45]	99.21 [45]	143.3 [65]	143.3 [65]
Weight enclosure IP55 lb [kg]	99.21 [45]	99.21 [45]	143.3 [65]	143.3 [65]
Weight enclosure IP66 lb [kg]	99.21 [45]	99.21 [45]	143.3 [65]	143.3 [65]
Efficiency ³⁾	0.97	0.97	0.97	0.97

Table 10.3 Line Power Supply 3x200–240 V AC

Adjustable frequency drive Typical Shaft Output [kW]	P1K1 1.1	P1K5 1.5	P2K2 2.2	P3K0 3	P4K0 4	P5K5 5.5	P7K5 7.5
Line Power Supply 3 x 380–480 V AC - Normal overload 110% for 1 minute							
Typical Shaft Output [HP] at 460 V	1.5	2.0	2.9	4.0	5.0	7.5	10
IP 20/Chassis ⁵⁾	A2	A2	A2	A2	A2	A3	A3
IP55/Type 12	A4/A5	A4/A5	A4/A5	A4/A5	A4/A5	A5	A5
IP66/NEMA 4X	A4/A5	A4/A5	A4/A5	A4/A5	A4/A5	A5	A5
Output current							
Continuous (3 x 380–440 V) [A]	3	4.1	5.6	7.2	10	13	16
Intermittent (3 x 380–440 V) [A]	3.3	4.5	6.2	7.9	11	14.3	17.6
Continuous (3 x 441–480 V) [A]	2.7	3.4	4.8	6.3	8.2	11	14.5
Intermittent (3 x 441–480 V) [A]	3.0	3.7	5.3	6.9	9.0	12.1	15.4
Continuous kVA (400 V AC) [kVA]	2.1	2.8	3.9	5.0	6.9	9.0	11.0
Continuous kVA (460 V AC) [kVA]	2.4	2.7	3.8	5.0	6.5	8.8	11.6
Max. input current							
Continuous (3 x 380–440 V) [A]	2.7	3.7	5.0	6.5	9.0	11.7	14.4
Intermittent (3 x 380–440 V) [A]	3.0	4.1	5.5	7.2	9.9	12.9	15.8
Continuous (3 x 441–480 V) [A]	2.7	3.1	4.3	5.7	7.4	9.9	13.0
Intermittent (3 x 441–480 V) [A]	3.0	3.4	4.7	6.3	8.1	10.9	14.3
Additional specifications							
Estimated power loss at rated max. load [W] ⁴⁾	58	62	88	116	124	187	255
IP20, IP21 max. cable cross-section (line power, motor, brake and load sharing) [mm ² /AWG] ²⁾	4, 4, 4 (12, 12, 12) (min. 0.2 (24))						
IP55, IP66 max. cable cross-section (line power, motor, brake and load sharing) [mm ² /AWG] ²⁾	4, 4, 4 (12, 12, 12)						
Max. cable cross-section with disconnect	6, 4, 4 (10, 12, 12)						
Weight enclosure IP20 lb [kg]	10.58 [4.8]	10.8 [4.9]	10.8 [4.9]	10.8 [4.9]	10.8 [4.9]	14.55 [6.6]	14.55 [6.6]
Weight enclosure IP21 lb [kg]							
Weight enclosure IP55 lb [kg] (A4/A5)	21.39/29. 76 [9.7/13.5]	21.39/29. 76 [9.7/13.5]	21.39/29. 76 [9.7/13.5]	21.39/29. 76 [9.7/13.5]	21.39/29. 76 [9.7/13.5]	31.31 [14.2]	31.31 [14.2]
Weight enclosure IP66 lb [kg] (A4/A5)	21.39/29. 76 [9.7/13.5]	21.39/29. 76 [9.7/13.5]	21.39/29. 76 [9.7/13.5]	21.39/29. 76 [9.7/13.5]	21.39/29. 76 [9.7/13.5]	31.31 [14.2]	31.31 [14.2]
Efficiency ³⁾	0.96	0.97	0.97	0.97	0.97	0.97	0.97

Table 10.4 Line Power Supply 3 x 380–480 V AC

Adjustable frequency drive Typical Shaft Output [kW]	P11K 11	P15K 15	P18K 18.5	P22K 22	P30K 30
Line Power Supply 3 x 380–480 V AC - Normal overload 110% for 1 minute					
Typical Shaft Output [HP] at 460 V	15	20	25	30	40
IP20/Chassis ⁶⁾	B3	B3	B3	B4	B4
IP21/NEMA 1	B1	B1	B1	B2	B2
IP55/Type 12	B1	B1	B1	B2	B2
IP66/NEMA 4X	B1	B1	B1	B2	B2
Output current					
Continuous (3 x 380–439 V) [A]	24	32	37.5	44	61
Intermittent (3 x 380–439 V) [A]	26.4	35.2	41.3	48.4	67.1
Continuous (3 x 440–480 V) [A]	21	27	34	40	52
Intermittent (3 x 440–480 V) [A]	23.1	29.7	37.4	44	61.6
Continuous kVA (400 V AC) [kVA]	16.6	22.2	26	30.5	42.3
Continuous kVA 460 V AC [kVA]	16.7	21.5	27.1	31.9	41.4
Max. input current					
Continuous (3 x 380–439 V) [A]	22	29	34	40	55
Intermittent (3 x 380–439 V) [A]	24.2	31.9	37.4	44	60.5
Continuous (3 x 440–480 V) [A]	19	25	31	36	47
Intermittent (3 x 440–480 V) [A]	20.9	27.5	34.1	39.6	51.7
Additional specifications					
Estimated power loss at rated max. load [W] ⁴⁾	278	392	465	525	698
IP20 max. cable cross-section (line power, brake, motor and load sharing)	16, 10, - (8, 8, -)		35, -, - (2, -, -)		35 (2)
IP21, IP55, IP66 max. cable cross-section (line power, motor) [mm ² /(AWG)]	10, 10, 16 (6, 8, 6)		35, 25, 25 (2, 4, 4)		50 (1)
IP21, IP55, IP66 max. cable cross-section (brake, load sharing) [mm ² /(AWG)]	10, 10, - (8, 8, -)		35, -, - (2, -, -)		50 (1)
With line power disconnect switch included:	16/6				
Weight enclosure IP20 lb [kg]	26.46 [12]	26.46 [12]	26.46 [12]	51.81 [23.5]	51.81 [23.5]
Weight enclosure IP21 lb [kg]	50.71 [23]	50.71 [23]	50.71 [23]	59.53 [27]	59.53 [27]
Weight enclosure IP55 lb [kg]	50.71 [23]	50.71 [23]	50.71 [23]	59.53 [27]	59.53 [27]
Weight enclosure IP66 lb [kg]	50.71 [23]	50.71 [23]	50.71 [23]	59.53 [27]	59.53 [27]
Efficiency ³⁾	0.98	0.98	0.98	0.98	0.98

Table 10.5 Line Power Supply 3 x 380–480 V AC

Adjustable frequency drive	P37K	P45K	P55K	P75K	P90K
Typical Shaft Output [kW]	37	45	55	75	90
Line Power Supply 3 x 380–480 V AC - Normal overload 110% for 1 minute					
Typical Shaft Output [HP] at 460 V	50	60	75	100	125
IP20/Chassis ⁶⁾	B4	C3	C3	C4	C4
IP21/NEMA 1	C1	C1	C1	C2	C2
IP55/Type 12	C1	C1	C1	C2	C2
IP66/NEMA 4X	C1	C1	C1	C2	C2
Output current					
Continuous (3 x 380–439 V) [A]	73	90	106	147	177
Intermittent (3 x 380–439 V) [A]	80.3	99	117	162	195
Continuous (3 x 440–480 V) [A]	65	80	105	130	160
Intermittent (3 x 440–480 V) [A]	71.5	88	116	143	176
Continuous kVA (400 V AC) [kVA]	50.6	62.4	73.4	102	123
Continuous kVA 460 V AC [kVA]	51.8	63.7	83.7	104	128
Max. input current					
Continuous (3 x 380–439 V) [A]	66	82	96	133	161
Intermittent (3 x 380–439 V) [A]	72.6	90.2	106	146	177
Continuous (3 x 440–480 V) [A]	59	73	95	118	145
Intermittent (3 x 440–480 V) [A]	64.9	80.3	105	130	160
Additional specifications					
Estimated power loss at rated max. load [W] ⁴⁾	739	843	1083	1384	1474
IP20 max. cable cross-section (line power, brake, motor and load sharing)	50 (1)		150 (300 MCM)		
IP21, IP55, IP66 max. cable cross-section (line power, motor) [mm ² /(AWG)]			150 (300 MCM)		
IP21, IP55, IP66 max. cable cross-section (brake, load sharing) [mm ² /(AWG)]			95 (3/0)		
With line power disconnect switch included:	35/2	35/2		70/3/0	185/ kcmil350
Weight enclosure IP20 lb [kg]	51.81 [23.5]	77.16 [35]	77.16 [35]	110.23 [50]	110.23 [50]
Weight enclosure IP21 lb [kg]	99.21 [45]	99.21 [45]	99.21 [45]	143.3 [65]	143.3 [65]
Weight enclosure IP55 lb [kg]	99.21 [45]	99.21 [45]	99.21 [45]	143.3 [65]	143.3 [65]
Weight enclosure IP66 lb [kg]	99.21 [45]	99.21 [45]	99.21 [45]	143.3 [65]	143.3 [65]
Efficiency ³⁾	0.98	0.98	0.98	0.98	0.99

Table 10.6 Line Power Supply 3 x 380–480 V AC

Size:	P1K1	P1K5	P2K2	P3K0	P3K7	P4K0	P5K5	P7K5	P11K
Line Power Supply 3 x 525–600 V AC Normal overload 110% for 1 minute									
Typical Shaft Output [kW]	1.1	1.5	2.2	3	3.7	4	5.5	7.5	11
IP20/Chassis	A3	A3	A3	A3	A2	A3	A3	A3	B3
IP21/NEMA 1	A3	A3	A3	A3	A2	A3	A3	A3	B1
IP55/Type 12	A5	A5	A5	A5	A5	A5	A5	A5	B1
IP66/NEMA 4X	A5	A5	A5	A5	A5	A5	A5	A5	B1
Output current									
Continuous (3 x 525–550 V) [A]	2.6	2.9	4.1	5.2	-	6.4	9.5	11.5	19
Intermittent (3 x 525–550 V) [A]	2.9	3.2	4.5	5.7	-	7.0	10.5	12.7	21
Continuous (3 x 525–600 V) [A]	2.4	2.7	3.9	4.9	-	6.1	9.0	11.0	18
Intermittent (3 x 525–600 V) [A]	2.6	3.0	4.3	5.4	-	6.7	9.9	12.1	20
Continuous kVA (525 V AC) [kVA]	2.5	2.8	3.9	5.0	-	6.1	9.0	11.0	18.1
Continuous kVA (575 V AC) [kVA]	2.4	2.7	3.9	4.9	-	6.1	9.0	11.0	17.9
Max. input current									
Continuous (3 x 525–600 V) [A]	2.4	2.7	4.1	5.2	-	5.8	8.6	10.4	17.2
Intermittent (3 x 525–600 V) [A]	2.7	3.0	4.5	5.7	-	6.4	9.5	11.5	19
Additional specifications									
Estim. power loss at rated max. load [W] ⁴⁾	50	65	92	122	-	145	195	261	300
IP20 max. cable cross-section (line power, motor, brake and load sharing) [mm ²]/[AWG]	4, 4, 4 (12, 12, 12) (min. 0.2 (24))								
IP55, IP66 max. cable cross-section (line power, motor, brake and load sharing) [mm ²]/[AWG]	4, 4, 4 (12, 12, 12) (min. 0.2 (24))								
Max. cable cross-section with disconnect	6, 4, 4 (12, 12, 12)								
Line power disconnect switch included:	4/12								
Weight IP20 lb [kg]	14.33 [6.5]	14.33 [6.5]	14.33 [6.5]	14.33 [6.5]	-	14.33 [6.5]	14.55 [6.6]	14.55 [6.6]	26.46 [12]
Weight IP21/55 lb [kg]	29.76 [13.5]	29.76 [13.5]	29.76 [13.5]	29.76 [13.5]	29.76 [13.5]	29.76 [13.5]	31.31 [14.2]	31.31 [14.2]	50.71 [23]
Efficiency ⁴⁾	0.97	0.97	0.97	0.97	-	0.97	0.97	0.97	0.98

Table 10.7 ⁵⁾ With brake and load sharing 95 / 4/0

Size:	P15K	P18K	P22K	P30K	P37K	P45K	P55K	P75K	P90K
Line Power Supply 3 x 525–600 V AC Normal overload 110% for 1 minute									
Typical Shaft Output [kW]	15	18.5	22	30	37	45	55	75	90
IP20/Chassis	B3	B3	B4	B4	B4	C3	C3	C4	C4
IP21/NEMA 1	B1	B1	B2	B2	C1	C1	C1	C2	C2
IP55/Type 12	B1	B1	B2	B2	C1	C1	C1	C2	C2
IP66/NEMA 4X	B1	B1	B2	B2	C1	C1	C1	C2	C2
Output current									
Continuous (3 x 525–550 V) [A]	23	28	36	43	54	65	87	105	137
Intermittent (3 x 525–550 V) [A]	25	31	40	47	59	72	96	116	151
Continuous (3 x 525–600 V) [A]	22	27	34	41	52	62	83	100	131
Intermittent (3 x 525–600 V) [A]	24	30	37	45	57	68	91	110	144
Continuous kVA (525 V AC) [kVA]	21.9	26.7	34.3	41	51.4	61.9	82.9	100	130.5
Continuous kVA (575 V AC) [kVA]	21.9	26.9	33.9	40.8	51.8	61.7	82.7	99.6	130.5
Max. input current									
Continuous (3 x 525–600 V) [A]	20.9	25.4	32.7	39	49	59	78.9	95.3	124.3
Intermittent (3 x 525–600 V) [A]	23	28	36	43	54	65	87	105	137
Additional specifications									
Estim. power loss at rated max. load [W] ⁴⁾	400	475	525	700	750	850	1100	1400	1500
IP20 max. cable cross-section (line power, motor, brake and load sharing) [mm ²]/[AWG]									
IP55, IP66 max. cable cross-section (line power, motor, brake and load sharing) [mm ²]/[AWG]									
Max. cable cross-section with disconnect									
Line power disconnect switch included:									
Weight IP20 lb [kg]	26.46 [12]	26.46 [12]	51.81 [23.5]	51.81 [23.5]	51.81 [23.5]	77.16 [35]	77.16 [35]	110.23 [50]	110.23 [50]
Weight IP21/55 lb [kg]	50.71 [23]	50.71 [23]	59.53 [27]	59.53 [27]	59.53 [27]	99.21 [45]	99.21 [45]	143.3 [65]	143.3 [65]
Efficiency ⁴⁾	0.98	0.98	0.98	0.98	0.98	0.98	0.98	0.98	0.98

Table 10.8 ⁵⁾ With brake and load sharing 95/ 4/0

10.1.1 Line Power Supply 3 x 525–690 V AC

Normal overload 110% for 1 minute							
Adjustable Frequency Drive	P1K1	P1K5	P2K2	P3K0	P4K0	P5K5	P7K5
Typical Shaft Output [kW]	1.1	1.5	2.2	3	4	5.5	7.5
Enclosure IP20 (only)	A3	A3	A3	A3	A3	A3	A3
Output current							
Continuous (3x525–550 V) [A]	2.1	2.7	3.9	4.9	6.1	9	11
Intermittent (3x525–550 V) [A]	2.3	3.0	4.3	5.4	6.7	9.9	12.1
Continuous kVA (3x551–690 V) [A]	1.6	2.2	3.2	4.5	5.5	7.5	10
Intermittent kVA (3x551–690 V) [A]	1.8	2.4	3.5	4.9	6.0	8.2	11
Continuous kVA 525 V AC	1.9	2.6	3.8	5.4	6.6	9	12
Continuous kVA 690 V AC	1.9	2.6	3.8	5.4	6.6	9	12
Max. input current							
Continuous (3x525–550 V) [A]	1.9	2.4	3.5	4.4	5.5	8	10
Intermittent (3x525–550 V) [A]	2.1	2.6	3.8	8.4	6.0	8.8	11
Continuous kVA (3x551–690 V) [A]	1.4	2.0	2.9	4.0	4.9	6.7	9
Intermittent kVA (3x551–690 V) [A]	1.5	2.2	3.2	4.4	5.4	7.4	9.9
Additional specifications							
IP20 max. cable cross-section ⁵⁾ (line power, motor, brake and load sharing) [mm ²]/(AWG)	[0.2-4]/(24-10)						
Estimated power loss at rated max. load [W] ⁴⁾	44	60	88	120	160	220	300
Weight, enclosure IP20 lb [kg]	14.55 [6.6]	14.55 [6.6]	14.55 [6.6]	14.55 [6.6]	14.55 [6.6]	14.55 [6.6]	14.55 [6.6]
Efficiency ⁴⁾	0.96	0.96	0.96	0.96	0.96	0.96	0.96

Table 10.9 Line Power Supply 3 x 525–690 V AC

Normal overload 110% for 1 minute						
Adjustable frequency drive	P11K	P15K	P18K	P22K	P45K	P55K
Typical Shaft Output [kW]	15	18.5	22	30	45	55
Typical Shaft Output [HP] at 575 V	16.4	20.1	24	33	60	75
IP21/NEMA 1	B2	B2	B2	B2	-	-
IP55/NEMA 12	B2	B2	B2	B2	-	-
IP20/Chassis	-	-	-	-	C3	C3
Output current						
Continuous (3 x 525–550 V) [A]	19	23	28	36	54	65
Intermittent (3 x 525–550 V) [A]	20.9	25.3	30.8	39.6	59.4	71.5
Continuous (3 x 551–690 V) [A]	18	22	27	34	52	62
Intermittent (3 x 551–690 V) [A]	19.8	24.2	29.7	37.4	57.2	68.2
Continuous kVA (550 V AC) [kVA]	18.1	21.9	26.7	34.3	51.4	62
Continuous kVA (575 V AC) [kVA]	17.9	21.9	26.9	33.8	62.2	74.1
Continuous kVA (690 V AC) [kVA]	21.5	26.3	32.3	40.6	62.2	74.1
Max. input current						
Continuous (3 x 525–690 V) [A]	19.5	24	29	36	-	-
Intermittent (3 x 525–690 V) [A]	21.5	26.4	31.9	39.6	-	-
Continuous (3 x 525–550 V) [A]	-	-	-	-	52	63
Intermittent (3 x 525–550 V) [A]	-	-	-	-	57.2	69.3
Continuous (3 x 551–690 V) [A]	-	-	-	-	50	60
Intermittent (3 x 525–690 V) [A]	-	-	-	-	55	66
Max. pre-fuses ¹⁾ [A]	63	63	63	80	100	125
Additional specifications						
Estimated power loss at rated max. load [W] ⁴⁾	285	335	375	430	592	720
Max. cable size (line power, motor, brake) [mm ²]/(AWG) ²⁾	[35]/(1/0)				[50]/(1)	
Weight IP21 lb [kg]	59.53 [27]	59.53 [27]	59.53 [27]	59.53 [27]	-	-
Weight IP55 lb [kg]	59.53 [27]	59.53 [27]	59.53 [27]	59.53 [27]	-	-
Weight IP20 lb [kg]	-	-	-	-	77.16 [35]	77.16 [35]
Efficiency ⁴⁾	0.98	0.98	0.98	0.98	0.98	0.98

Table 10.10 Line Power Supply 3 x 525–690 V AC IP20-Chassis/IP21-IP55/NEMA 1-NEMA 12

Normal overload 110% for 1 minute					
Adjustable frequency drive	P30K	P37K	P45K	P55K	P75K
Typical Shaft Output [kW]	37	45	55	75	90
Typical Shaft Output [HP] at 575 V	40	50	60	75	100
IP21/NEMA 1	C2	C2	C2	C2	C2
IP55/NEMA 12	C2	C2	C2	C2	C2
Output current					
Continuous (3 x 525–550 V) [A]	43	54	65	87	105
Intermittent (3 x 525–550 V) [A]	47.3	59.4	71.5	95.7	115.5
Continuous (3 x 551–690 V) [A]	41	52	62	83	100
Intermittent (3 x 551–690 V) [A]	45.1	57.2	68.2	91.3	110
Continuous kVA (550 V AC) [kVA]	41	51.4	61.9	82.9	100
Continuous kVA (575 V AC) [kVA]	40.8	51.8	61.7	82.7	99.6
Continuous kVA (690 V AC) [kVA]	49	62.1	74.1	99.2	119.5
Max. input current					
Continuous (3 x 525–690 V) [A]	49	59	71	87	99
Intermittent (3 x 525–690 V) [A]	53.9	64.9	78.1	95.7	108.9
Max. pre-fuses ¹⁾ [A]	100	125	160	160	160
Additional specifications					
Estimated power loss at rated max. load [W] ⁴⁾	592	720	880	1200	1440
Max. cable size (line power, motor, brake) [mm ²]/(AWG) ²⁾				[95]/(4/0)	
Weight IP21 lb [kg]	143.3 [65]	143.3 [65]	143.3 [65]	143.3 [65]	143.3 [65]
Weight IP55 lb [kg]	143.3 [65]	143.3 [65]	143.3 [65]	143.3 [65]	143.3 [65]
Efficiency ⁴⁾	0.98	0.98	0.98	0.98	0.98

Table 10.11 Line Power Supply 3 x 525–690 V AC IP21-IP55/NEMA 1-NEMA 12

¹⁾ For type of fuse, see 10.3 Fuse Specifications

²⁾ American Wire Gauge

³⁾ Measured using 16 ft [5 m] shielded motor cables at rated load and rated frequency

⁴⁾ The typical power loss is at normal load conditions and expected to be within ±15% (tolerance relates to variety in voltage and cable conditions).

Values are based on a typical motor efficiency (eff2/eff3 border line). Lower efficiency motors will also add to the power loss in the adjustable frequency drive and vice versa.

If the switching frequency is raised from nominal, the power losses may rise significantly.

Keypad and typical control card power consumption rates are included. Further options and customer load may add up to 30 W to the losses. (Though typically only 4 W extra for a fully loaded control card or options for slot A or slot B, each).

Although measurements are made with state of the art equipment, some measurement inaccuracy must be allowed for (±5%).

⁵⁾ (A2+A3 may be converted to IP21 using a conversion kit. (See also Mechanical mounting and IP21/Type 1 Enclosure kit in the Design Guide.))

⁶⁾ (B3+B4 and C3+C4 may be converted to IP21 using a conversion kit. (See also items Mechanical mounting and IP21/Type 1 Enclosure kit in the Design Guide.))

10.2 General Technical Data

Line power supply

Supply Terminals	L1, L2, L3
Supply voltage	200–240 V ±10%
Supply voltage	380–480 V/525–600 V ±10%
Supply voltage	525–690 V ±10%

AC line voltage low/line drop-out:

During low AC line voltage or a line drop-out, the FC drive continues until the intermediate circuit voltage drops below the minimum stop level, which corresponds typically to 15% below the adjustable frequency drive's lowest rated supply voltage. Power-up and full torque cannot be expected at AC line voltage lower than 10% below the adjustable frequency drive's lowest rated supply voltage.

Supply frequency	50/60 Hz ±5%
Max. temporary imbalance between line phases	3.0% of rated supply voltage
True Power Factor (λ)	≥ 0.9 nominal at rated load
Displacement Power Factor ($\cos \phi$)	near unity (> 0.98)
Switching on input supply L1, L2, L3 (power-ups) ≤ 7.5 kW	maximum 2 times/min.
Switching on input supply L1, L2, L3 (power-ups) 11–75 kW	maximum 1 time/min.
Switching on input supply L1, L2, L3 (power-ups) ≥ 90 kW	maximum 1 time/2 min.
Environment according to EN60664-1	overvoltage category III/pollution degree 2

The unit is suitable for use on a circuit capable of delivering not more than 100,000 RMS symmetrical Amperes, 240/500/600/690 V maximum.

Motor output (U, V, W)

Output voltage	0–100% of supply voltage
Output frequency (1.1–90 kW)	0–590 Hz
Output frequency (110–250 kW)	0–590 ¹⁾ Hz
Switching on output	Unlimited
Ramp times	1–3600 s

¹⁾ Voltage and power dependent

Torque characteristics

Starting torque (Constant torque)	maximum 110% for 60 s ¹⁾
Starting torque	maximum 135% up to 0.5 s ¹⁾
Overload torque (Constant torque)	maximum 110% for 60 s ¹⁾
Starting torque (Variable torque)	maximum 110% for 60 s ¹⁾
Overload torque (Variable torque)	maximum 110% for 60 s
Torque rise time in VVC ^{plus} (independent of fsw)	10 ms

¹⁾ Percentage relates to the nominal torque.

²⁾ The torque response time depends on application and load but as a general rule, the torque step from 0 to reference is 4–5 x torque rise time.

Cable lengths and cross-sections for control cables¹⁾

Max. motor cable length, shielded	500 ft [150 m]
Max. motor cable length, non-shielded	1,000 ft [300 m]
Maximum cross-section to control terminals, flexible/ rigid wire without cable end sleeves	0.0023 in ² [1.5 mm ²]/16 AWG
Maximum cross-section to control terminals, flexible wire with cable end sleeves	0.0016 in ² [1 mm ²]/18 AWG
Maximum cross-section to control terminals, flexible wire with cable end sleeves with collar	0.0008 in ² [0.5 mm ²]/20 AWG
Minimum cross-section to control terminals	0.25 mm ² /24AWG

¹⁾For power cables, see electrical data tables.

Digital inputs

Programmable digital inputs	4 (6) ¹⁾
Terminal number	18, 19, 27 ¹⁾ , 29 ¹⁾ , 32, 33,
Logic	PNP or NPN
Voltage level	0–24 V DC
Voltage level, logic '0' PNP	<5 V DC
Voltage level, logic '1' PNP	>10 V DC
Voltage level, logic '0' NPN ²⁾	>19 V DC
Voltage level, logic '1' NPN ²⁾	<14 V DC
Maximum voltage on input	28 V DC
Pulse frequency ranges	0–110 kHz
(Duty cycle) Min. pulse width	4.5 ms
Input resistance, R _i	Approx. 4 kΩ

Analog inputs

Number of analog inputs	2
Terminal number	53, 54
Modes	Voltage or current
Mode select	Switch S201 and switch S202
Voltage mode	Switch S201/switch S202 = OFF (U)
Voltage level	-10 to +10 V (scaleable)
Input resistance, R _i	approx. 10 kΩ
Max. voltage	±20 V
Current mode	Switch S201/switch S202 = ON (I)
Current level	0/4 to 20 mA (scaleable)
Input resistance, R _i	approx. 200 Ω
Max. current	30 mA
Resolution for analog inputs	10 bit (+ sign)
Accuracy of analog inputs	Max. error 0.5% of full scale
Bandwidth	20 Hz/100 Hz

The analog inputs are galvanically isolated from the supply voltage (PELV) and other high-voltage terminals.

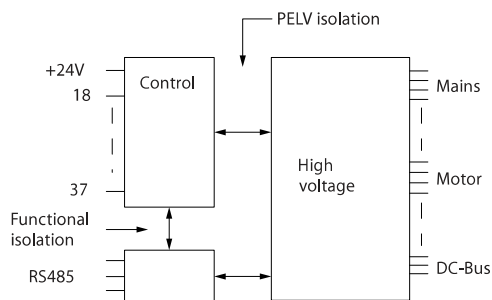

130BA117.10

Figure 10.1 PELV Isolation

Pulse

Programmable pulse	2/1
Terminal number pulse	29 ¹⁾ , 33 ²⁾ / 33 ³⁾
Max. frequency at terminal 29, 33	110 kHz (push-pull driven)
Max. frequency at terminal 29, 33	5 kHz (open collector)
Min. frequency at terminal 29, 33	4 Hz
Voltage level	see 10.2.1 Digital Inputs
Maximum voltage on input	28 V DC
Input resistance, R _i	approx. 4 kΩ
Pulse input accuracy (0.1–1 kHz)	Max. error: 0.1% of full scale
Encoder input accuracy (1–11 kHz)	Max. error: 0.05% of full scale

The pulse and encoder inputs (terminals 29, 32, 33) are galvanically isolated from the supply voltage (PELV) and other high-voltage terminals.

¹⁾ TR200 only

²⁾ Pulse inputs are 29 and 33

Analog output

Number of programmable analog outputs	1
Terminal number	42
Current range at analog output	0/4–20 mA
Max. load GND - analog output	500 Ω
Accuracy on analog output	Max. error: 0.5% of full scale
Resolution on analog output	12 bit

The analog output is galvanically isolated from the supply voltage (PELV) and other high-voltage terminals.

Control card, RS-485 serial communication

Terminal number	68 (P,TX+, RX+), 69 (N,TX-, RX-)
Terminal number 61	Common for terminals 68 and 69

The RS-485 serial communication circuit is functionally separated from other central circuits and galvanically isolated from the supply voltage (PELV).

Digital output

Programmable digital/pulse outputs	2
Terminal number	27, 29 ¹⁾
Voltage level at digital/frequency output	0–24 V
Max. output current (sink or source)	40 mA
Max. load at frequency output	1 kΩ
Max. capacitive load at frequency output	10 nF
Minimum output frequency at frequency output	0 Hz
Maximum output frequency at frequency output	32 kHz
Accuracy of frequency output	Max. error: 0.1% of full scale
Resolution of frequency outputs	12 bit

¹⁾ Terminal 27 and 29 can also be programmed as input.

The digital output is galvanically isolated from the supply voltage (PELV) and other high-voltage terminals.

Control card, 24 V DC output

Terminal number	12, 13
Output voltage	24 V +1, -3 V
Max. load	200 mA

The 24 V DC supply is galvanically isolated from the supply voltage (PELV), but has the same potential as the analog and digital inputs and outputs.

Relay outputs

Programmable relay outputs	all kW: 2
Relay 01 Terminal number	1-3 (break), 1-2 (make)
Max. terminal load (AC-1) ¹⁾ on 1-3 (NC), 1-2 (NO) (Resistive load)	240 V AC, 2 A
Max. terminal load (AC-15) ¹⁾ (Inductive load @ cosφ 0.4)	240 V AC, 0.2 A
Max. terminal load (DC-1) ¹⁾ on 1-2 (NO), 1-3 (NC) (Resistive load)	60 V DC, 1 A
Max. terminal load (DC-13) ¹⁾ (Inductive load)	24 V DC, 0.1 A
Relay 02 (TR200 only) Terminal number	4-6 (break), 4-5 (make)
Max. terminal load (AC-1) ¹⁾ on 4-5 (NO) (Resistive load) ²⁾³⁾ Overtoltage cat. II	400 V AC, 2 A
Max. terminal load (AC-15) ¹⁾ on 4-5 (NO) (Inductive load @ cosφ 0.4)	240 V AC, 0.2 A
Max. terminal load (DC-1) ¹⁾ on 4-5 (NO) (resistive load)	80 V DC, 2 A
Max. terminal load (DC-13) ¹⁾ on 4-5 (NO) (inductive load)	24 V DC, 0.1 A
Max. terminal load (AC-1) ¹⁾ on 4-6 (NC) (resistive load)	240 V AC, 2 A
Max. terminal load (AC-15) ¹⁾ on 4-6 (NC) (Inductive load @ cosφ 0.4)	240 V AC, 0.2 A
Max. terminal load (DC-1) ¹⁾ on 4-6 (NC) (resistive load)	50 V DC, 2 A
Max. terminal load (DC-13) ¹⁾ on 4-6 (NC) (inductive load)	24 V DC, 0.1 A
Min. terminal load on 1-3 (NC), 1-2 (NO), 4-6 (NC), 4-5 (NO)	24 V DC 10 mA, 24 V AC 20 mA
Environment according to EN 60664-1	overtoltage category III/pollution degree 2

¹⁾ IEC 60947 part 4 and 5

The relay contacts are galvanically isolated from the rest of the circuit by reinforced isolation (PELV).

²⁾ Overtoltage Category II

³⁾ UL applications 300 V AC 2A

Control card, 10 V DC output

Terminal number	50
Output voltage	10.5 V ±0.5 V
Max. load	15 mA

The 10 V DC supply is galvanically isolated from the supply voltage (PELV) and other high-voltage terminals.

Control characteristics

Resolution of output frequency at 0–590 Hz	± 0.003 Hz
Repeat accuracy of <i>Precise start/stop</i> (terminals 18, 19)	≤± 0.1 ms
System response time (terminals 18, 19, 27, 29, 32, 33)	≤ 2 ms
Speed control range (open-loop)	1:100 of synchronous speed
Speed control range (closed-loop)	1:1000 of synchronous speed
Speed accuracy (open-loop)	30–4000 rpm: error ±8 rpm
Speed accuracy (closed-loop), depending on resolution of feedback device	0–6000 rpm: error ±0.15 rpm

All control characteristics are based on a 4-pole asynchronous motor

Environment

Enclosure	IP20 ¹⁾ /Type 1, IP21 ²⁾ /Type 1, IP55/Type 12, IP66
Vibration test	1.0 g
Max. relative humidity	5%–93% (IEC 721-3-3; Class 3K3 (non-condensing) during operation
Aggressive environment (IEC 60068-2-43) H ₂ S test	class Kd
Ambient temperature ³⁾	Max. 122 °F [50 °C] (24-hour average maximum 113 °F [45 °C])

¹⁾ Only for ≤ 3.7 kW (200–240 V), ≤ 7.5 kW (400–480 V)

²⁾ As enclosure kit for ≤ 3.7 kW (200–240 V), ≤ 7.5 kW (400–480 V)

³⁾ Derating for high ambient temperature, see special conditions in the Design Guide

Minimum ambient temperature during full-scale operation	32 °F [0 °C]
Minimum ambient temperature at reduced performance	14 °F [-10 °C]
Temperature during storage/transport	-13 to +149/158 °F [-25 to +65/70 °C]
Maximum altitude above sea level without derating	3300 ft [1000 m]

Derating for high altitude, see special conditions in the Design Guide.

EMC standards, Emission	EN 61800-3, EN 61000-6-3/4, EN 55011 EN 61800-3, EN 61000-6-1/2,
EMC standards, Immunity	EN 61000-4-2, EN 61000-4-3, EN 61000-4-4, EN 61000-4-5, EN 61000-4-6

See section on special conditions in the Design Guide.

Control card performance

Scan interval	1 ms
---------------	------

Control card, USB serial communication

USB standard	1.1 (Full speed)
USB plug	USB type B “device” plug

Connection to PC is carried out via a standard host/device USB cable.

The USB connection is galvanically isolated from the supply voltage (PELV) and other high-voltage terminals.

The USB ground connection is not galvanically isolated from protection ground. Use only an isolated laptop as PC connection to the USB connector on the adjustable frequency drive.

Protection and Features

- Electronic thermal motor protection against overload.
- Temperature monitoring of the heatsink ensures that the adjustable frequency drive trips if the temperature reaches a predefined level. An overload temperature cannot be reset until the temperature of the heatsink is below the values stated in the tables on the following pages (guideline - these temperatures may vary for different power sizes, frame sizes, enclosure ratings, etc.).
- The adjustable frequency drive is protected against short-circuits on motor terminals U, V, W.
- If a line phase is missing, the adjustable frequency drive trips or issues a warning (depending on the load).
- Monitoring of the intermediate circuit voltage ensures that the adjustable frequency drive trips if the intermediate circuit voltage is too low or too high.
- The adjustable frequency drive constantly checks for critical levels of internal temperature, load current, high voltage on the intermediate circuit and low motor speeds. As a response to a critical level, the adjustable frequency drive can adjust the switching frequency and/or change the switching pattern in order to ensure the performance of the adjustable frequency drive.

10.3 Fuse Specifications

10.3.1 Branch Circuit Protection Fuses

For compliance with IEC/EN 61800-5-1 electrical standards, the following fuses are recommended.

Adjustable frequency drive	Maximum fuse size	Voltage	Type
200–240 V - T2			
1K1-1K5	16A ¹	200–240	type gG
2K2	25A ¹	200–240	type gG
3K0	25A ¹	200–240	type gG
3K7	35A ¹	200–240	type gG
5K5	50A ¹	200–240	type gG
7K5	63A ¹	200–240	type gG
11K	63A ¹	200–240	type gG
15K	80A ¹	200–240	type gG
18K5	125A ¹	200–240	type gG
22K	125A ¹	200–240	type gG
30K	160A ¹	200–240	type gG
37K	200A ¹	200–240	type aR
45K	250A ¹	200–240	type aR
380–480 V - T4			
1K1-1K5	10A ¹	380–500	type gG
2K2-3K0	16A ¹	380–500	type gG
4K0-5K5	25A ¹	380–500	type gG
7K5	35A ¹	380–500	type gG
11K-15K	63A ¹	380–500	type gG
18K	63A ¹	380–500	type gG
22K	63A ¹	380–500	type gG
30K	80A ¹	380–500	type gG
37K	100A ¹	380–500	type gG
45K	125A ¹	380–500	type gG
55K	160A ¹	380–500	type gG
75K	250A ¹	380–500	type aR
90K	250A ¹	380–500	type aR
1) Max. fuses - see national/international regulations for selecting an applicable fuse size.			

Table 10.12 EN50178 fuses 200 V to 480 V

Enclosure Size	Power [kW]	Recommended fuse size	Recommended max. fuse	Recommended circuit breaker Danfoss	Max. trip level [A]
A3	1.1	gG-6	gG-25	CTI25M 10-16	16
	1.5	gG-6	gG-25	CTI25M 10-16	16
	2.2	gG-6	gG-25	CTI25M 10-16	16
	3	gG-10	gG-25	CTI25M 10-16	16
	4	gG-10	gG-25	CTI25M 10-16	16
	5.5	gG-16	gG-25	CTI25M 10-16	16
	7.5	gG-16	gG-25	CTI25M 10-16	16
B2	11	gG-25	gG-63		
	15	gG-25	gG-63		
	18	gG-32			
	22	gG-32			
C2	30	gG-40			
	37	gG-63	gG-80		
	45	gG-63	gG-100		
	55	gG-80	gG-125		
	75	gG-100	gG-160		
C3	37	gG-100	gG-125		
	45	gG-125	gG-160		
D	37	gG-125	gG-125		
	45	gG-160	gG-160		
	55-75	gG-200	gG-200		
	90	aR-250	aR-250		
	110	aR-315	aR-315		
	132-160	aR-350	aR-350		
	200	aR-400	aR-400		
	250	aR-500	aR-500		
E	355-400	aR-700	aR-700		
	500-560	aR-900	aR-900		
F	630-900	aR-1600	aR-1600		
	1000	aR-2000	aR-2000		
	1200	aR-2500	aR-2500		

Table 10.13 525-690 V, Frame Sizes A, C, D, E and F (non-UL fuses)

10.3.2 UL and cUL Branch Circuit Protection Fuses

For compliance with UL and cUL electrical standards, the following fuses or UL/cUL approved substitutions are required. Maximum fuse ratings are listed.

Adjustable frequency drive	Bussmann	Bussmann	Bussmann	SIBA	Littel fuse	Ferraz-Shawmut	Ferraz-Shawmut
200–240 V							
[kW]	Type RK1	Type J	Type T	Type RK1	Type RK1	Type CC	Type RK1
1K1	KTN-R10	JKS-10	JJN-10	5017906-010	KLN-R10	ATM-R10	A2K-10R
1K5	KTN-R15	JKS-15	JJN-15	5017906-015	KLN-R15	ATM-R15	A2K-15R
2K2	KTN-R20	JKS-20	JJN-20	5012406-020	KLN-R20	ATM-R20	A2K-20R
3K0	KTN-R25	JKS-25	JJN-25	5012406-025	KLN-R25	ATM-R25	A2K-25R
3K7	KTN-R30	JKS-30	JJN-30	5012406-030	KLN-R30	ATM-R30	A2K-30R
5K5	KTN-R50	JKS-50	JJN-50	5012406-050	KLN-R50	-	A2K-50R
7K5	KTN-R50	JKS-60	JJN-60	5012406-050	KLN-R60	-	A2K-50R
11K	KTN-R60	JKS-60	JJN-60	5014006-063	KLN-R60	A2K-60R	A2K-60R
15K	KTN-R80	JKS-80	JJN-80	5014006-080	KLN-R80	A2K-80R	A2K-80R
18K5	KTN-R125	JKS-150	JJN-125	2028220-125	KLN-R125	A2K-125R	A2K-125R
22K	KTN-R125	JKS-150	JJN-125	2028220-125	KLN-R125	A2K-125R	A2K-125R
30K	FWX-150	-	-	2028220-150	L25S-150	A25X-150	A25X-150
37K	FWX-200	-	-	2028220-200	L25S-200	A25X-200	A25X-200
45K	FWX-250	-	-	2028220-250	L25S-250	A25X-250	A25X-250
380–480 V, 525–600 V							
[kW]	Type RK1	Type J	Type T	Type RK1	Type RK1	Type CC	Type RK1
1K1	KTS-R6	JKS-6	JJS-6	5017906-006	KLS-R6	ATM-R6	A6K-6R
1K5-2K2	KTS-R10	JKS-10	JJS-10	5017906-010	KLS-R10	ATM-R10	A6K-10R
3K0	KTS-R15	JKS-15	JJS-15	5017906-016	KLS-R16	ATM-R16	A6K-16R
4K0	KTS-R20	JKS-20	JJS-20	5017906-020	KLS-R20	ATM-R20	A6K-20R
5K5	KTS-R25	JKS-25	JJS-25	5017906-025	KLS-R25	ATM-R25	A6K-25R
7K5	KTS-R30	JKS-30	JJS-30	5012406-032	KLS-R30	ATM-R30	A6K-30R
11K	KTS-R40	JKS-40	JJS-40	5014006-040	KLS-R40	-	A6K-40R
15K	KTS-R40	JKS-40	JJS-40	5014006-040	KLS-R40	-	A6K-40R
18K	KTS-R50	JKS-50	JJS-50	5014006-050	KLS-R50	-	A6K-50R
22K	KTS-R60	JKS-60	JJS-60	5014006-063	KLS-R60	-	A6K-60R
30K	KTS-R80	JKS-80	JJS-80	2028220-100	KLS-R80	-	A6K-80R
37K	KTS-R100	JKS-100	JJS-100	2028220-125	KLS-R100	-	A6K-100R
45K	KTS-R125	JKS-150	JJS-150	2028220-125	KLS-R125	-	A6K-125R
55K	KTS-R150	JKS-150	JJS-150	2028220-160	KLS-R150	-	A6K-150R
75K	FWH-220	-	-	2028220-200	L50S-225	-	A50-P225
90K	FWH-250	-	-	2028220-250	L50S-250	-	A50-P250

Table 10.14 UL fuses, 200–240 V and 380–600 V

Recommended max. fuse						
	Bussmann	Bussmann	Bussmann	Bussmann	Bussmann	Bussmann
[kW]	Type RK1	Type J	Type T	Type CC	Type CC	Type CC
1.1	KTS-R-5	JKS-5	JJS-6	FNQ-R-5	KTK-R-5	LP-CC-5
1.5–2.2	KTS-R10	JKS-10	JJS-10	FNQ-R-10	KTK-R-10	LP-CC-10
3	KTS-R-15	JKS-15	JJS-15	FNQ-R-15	KTK-R-15	LP-CC-15
4	KTS-R-20	JKS-20	JJS-20	FNQ-R-20	KTK-R-20	LP-CC-20
5.5	KTS-R25	JKS-25	JJS-25	FNQ-R-25	KTK-R-25	LP-CC-25
7.5	KTS-R-30	JKS-30	JJS-30	FNQ-R-30	KTK-R-30	LP-CC-30
11–15	KTS-R-35	JKS-35	JJS-35			
18	KTS-R-45	JKS-45	JJS-45			
22	KTS-R50	JKS-50	JJS-50			
30	KTS-R-60	JKS-60	JJS-60			
37	KTS-R-80	JKS-80	JJS-80			
45	KTS-R-100	JKS-100	JJS-100			
55	KTS-R125	JKS-125	JJS-125			
75	KTS-R150	JKS-150	JJS-150			
90	KTS-R175	JKS-175	JJS-175			

Table 10.15 525–600 V, Frame Sizes A, B and C

Recommended max. fuse				
	SIBA	Littel fuse	Ferraz-Shawmut	Ferraz-Shawmut
[kW]	Type RK1	Type RK1	Type RK1	Type J
0.37–1.1	5017906-005	KLSR005	A6K-5R	HSJ6
1.5–2.2	5017906-010	KLSR010	A6K-10R	HSJ10
3	5017906-016	KLSR015	A6K-15R	HSJ15
4	5017906-020	KLSR020	A6K-20R	HSJ20
5.5	5017906-025	KLSR25	A6K-25R	HSJ25
7.5	5017906-030	KLSR030	A6K-30R	HSJ30
11–15	5014006-040	KLSR035	A6K-35R	HSJ35
18	5014006-050	KLSR045	A6K-45R	HSJ45
22	5014006-050	KLS-R50	A6K-50R	HSJ50
30	5014006-063	KLSR060	A6K-60R	HSJ60
37	5014006-080	KLSR075	A6K-80R	HSJ80
45	5014006-100	KLSR100	A6K-100R	HSJ100
55	2028220-125	KLS-125	A6K-125R	HSJ125
75	2028220-150	KLS-150	A6K-150R	HSJ150
90	2028220-200	KLS-175	A6K-175R	HSJ175

Table 10.16 525–600 V, Frame Sizes A, B and C

Recommended max. fuse*								
[kW]	Max. prefuse	Bussmann E52273 RK1/JDDZ	Bussmann E4273 J/JDDZ	Bussmann E4273 T/JDDZ	SIBA E180276 RK1/JDDZ	Littelfuse E81895 RK1/JDDZ	Ferraz- Shawmut E163267/E2137 RK1/JDDZ	Ferraz-Shawmut E2137 J/HSJ
11	30 A	KTS-R-30	JKS-30	JKJS-30	5017906-030	KLS-R-030	A6K-30-R	HST-30
15-18.5	45 A	KTS-R-45	JKS-45	JJS-45	5014006-050	KLS-R-045	A6K-45-R	HST-45
22	60 A	KTS-R-60	JKS-60	JJS-60	5014006-063	KLS-R-060	A6K-60-R	HST-60
30	80 A	KTS-R-80	JKS-80	JJS-80	5014006-080	KLS-R-075	A6K-80-R	HST-80
37	90 A	KTS-R-90	JKS-90	JJS-90	5014006-100	KLS-R-090	A6K-90-R	HST-90
45	100 A	KTS-R-100	JKS-100	JJS-100	5014006-100	KLS-R-100	A6K-100-R	HST-100
55	125 A	KTS-R-125	JKS-125	JJS-125	2028220-125	KLS-150	A6K-125-R	HST-125
75	150 A	KTS-R-150	JKS-150	JJS-150	2028220-150	KLS-175	A6K-150-R	HST-150

* UL compliance 525-600 V only

Table 10.17 525-690 V, Frame Sizes B and C

10.3.3 Substitute Fuses for 240 V

Original fuse	Manufacturer	Substitute fuses
KTN	Bussmann	KTS
FWX	Bussmann	FWH
KLNR	LITTEL FUSE	KLSR
L50S	LITTEL FUSE	L50S
A2KR	FERRAZ SHAWMUT	A6KR
A25X	FERRAZ SHAWMUT	A50X

Table 10.18 Substitute Fuses

10.4 Connection Tightening Torques

Enclosure	Power (kW)			Torque (Nm)						
	200-240 V	380-480/500 V	525-600 V	525-690 V	Line power	Motor	DC connection	Brake	Ground	Relay
A2	1.1-2.2	1.1-4.0			1.8	1.8	1.8	1.8	3	0.6
A3	3.0-3.7	5.5-7.5	1.1-7.5	1.1-7.5	1.8	1.8	1.8	1.8	3	0.6
A4	1.1-2.2	1.1-4.0			1.8	1.8	1.8	1.8	3	0.6
A5	1.1-3.7	1.1-7.5	1.1-7.5		1.8	1.8	1.8	1.8	3	0.6
B1	5.5-11	11-18	11-18		1.8	1.8	1.5	1.5	3	0.6
B2	15	22-30	22-30	11-30	4.5	4.5	3.7	3.7	3	0.6
B3	5.5-11	11-18	11-18		1.8	1.8	1.8	1.8	3	0.6
B4	15-18	22-37	22-37	11-37	4.5	4.5	4.5	4.5	3	0.6
C1	18-30	37-55	37-55		10	10	10	10	3	0.6
C2	37-45	75-90	75-90	37-90	14/24 ¹⁾	14/24 ¹⁾	14	14	3	0.6
C3		45-55	45-55	45-55	10	10	10	10	3	0.6
C4	37-55	75-90	75-90		14/24 ¹⁾	14/24 ¹⁾	14	14	3	0.6

Table 10.19 Tightening of Terminals

¹⁾ For different cable dimensions x/y, where $x \leq 0.147 \text{ in}^2 [95 \text{ mm}^2]$ and $y \geq 0.147 \text{ in}^2 [95 \text{ mm}^2]$.

Index

A		Control	
A53.....	2-14	Cables.....	2-13
A54.....	2-14	Card.....	8-4
AC		Card, USB Serial Communication.....	10-16
Input.....	1-5, 2-10	Signal.....	5-1, 5-2, 7-1
Line Power.....	1-4, 1-5, 2-3, 2-10	System.....	1-4
Line Voltage.....	4-2, 4-3	Terminals.....	2-3, 2-13, 3-4, 4-3, 7-1, 7-3, 5-2
Waveform.....	1-4, 1-5	Wire.....	2-13
Accel Time	3-6	Wiring.....	2-5, 2-6, 2-13, 3-2
Adjustable		Cooling	
Frequency Drive.....	2-11	Cooling.....	2-1
Frequency Drive Block Diagram.....	1-4	Clearance.....	3-2
Frequency Drive Identification.....	1-6	Current	
Alarm Log	4-2	Limit.....	3-6
Alarm/Warning Code List	8-4	Rating.....	2-1, 8-5
Alarms	8-1	D	
AMA		DC	
AMA.....	8-5, 8-8	Current.....	1-5, 7-2
With T27 Connected.....	6-1	Link.....	8-4
Without T27 Connected.....	6-1	Derating	2-1
Analog		Digital	
Input.....	8-4	Input.....	2-14, 7-3, 8-5
Inputs.....	2-11	Inputs.....	2-11, 7-3
Output.....	2-11	Disconnect	
Signal.....	8-4	Switch.....	3-3
Approvals	0-i	Switches.....	3-1
Auto		Downloading Data From The LCP	4-4
Auto.....	4-3	E	
Mode.....	4-2	Electrical Noise	2-6
On.....	4-3, 7-1, 7-3	EMC	3-2
Automatic Motor Adaptation	3-6, 7-1	EN50178 Fuses 200 V To 480 V	10-17
Auto-reset	4-1	External	
AWG	10-1	Commands.....	1-5, 7-1, 7-3
B		Controllers.....	1-4
Backplate	2-2	Interlock.....	2-14, 5-3
Braking	7-1	Voltage.....	5-2
C		F	
Circuit Breakers	3-2	Fault Log	4-2
Clearance		Feedback	2-14, 3-2, 8-8, 8-9, 7-2
Clearance.....	2-2	Floating Delta	2-10
Requirements.....	2-1	Full Load Current	2-1
Closed-loop	2-14	Functional Testing	1-4, 3-6
Communication Option	8-7	Fuses	3-2, 8-7, 9-1, 10-17, 10-19
Conduit	2-5, 3-2, 2-8	Fusing	2-5, 3-2

G
Ground

Connections.....	2-6, 3-2
Loops.....	2-13
Wire.....	2-6, 3-2

Grounded Delta	2-10
-----------------------------	------

Grounding

Grounding.....	2-6, 2-7, 2-10, 3-1, 3-2
Using Shielded Cable.....	2-7

H
Hand

Hand.....	3-6, 4-3
On.....	3-6, 4-3, 7-1

Harmonics	1-5
------------------------	-----

I

IEC 61800-3	2-10
--------------------------	------

Induced Voltage	2-5
------------------------------	-----

InitializationManual Initialization	4-5
--	-----

Input

Current.....	2-10
Disconnect.....	2-10
Power.....	1-5, 2-6, 2-10, 3-1, 3-2, 8-1
Signal.....	5-2
Signals.....	2-14
Terminal.....	8-4
Terminals.....	2-3, 2-10, 2-14, 3-1
Voltage.....	3-3, 8-1

Installation	1-4, 2-1, 2-2, 2-5, 2-13, 3-2, 3-3
---------------------------	------------------------------------

Isolated Line Power	2-10
----------------------------------	------

L

Leakage Current	3-1
------------------------------	-----

Lifting	2-2
----------------------	-----

Line Power	2-5
-------------------------	-----

Literature	1-1
-------------------------	-----

Local

Control.....	4-1, 4-3, 7-1
Control Panel.....	4-1
Mode.....	3-6
Operation.....	4-1
Start.....	3-6

M

Main Menu	5-1, 4-2
------------------------	----------

Mains Voltage	7-2
----------------------------	-----

Menu

Keys.....	4-1, 4-2
Structure.....	4-3, 5-5

Motor

Cables.....	2-1, 2-5, 2-7, 3-6
Current.....	1-5, 3-6, 4-2, 8-8
Data.....	3-4, 3-6, 8-5, 8-9, 3-6
Frequency.....	4-2
Output.....	10-12
Power.....	2-3, 2-5, 2-6, 4-2, 8-8
Protection.....	2-5, 10-16
Rotation.....	3-6, 4-2
Speeds.....	3-3
Status.....	1-4
Wiring.....	2-5, 2-7, 3-2

Mounting	2-2
-----------------------	-----

Multiple

Adjustable Frequency Drives.....	2-5, 2-7
Motors.....	3-1

N

Navigation Keys	3-3, 5-1, 4-3
------------------------------	---------------

Noise Isolation	2-5, 3-2
------------------------------	----------

O

Open-loop	2-14, 5-1
------------------------	-----------

Operation Keys	4-3
-----------------------------	-----

Optional Equipment	2-7, 2-14, 3-3, 1-4
---------------------------------	---------------------

Output

Current.....	7-2, 8-5
Signal.....	5-4
Terminals.....	2-3, 3-1

Overcurrent	7-2
--------------------------	-----

Overload Protection	2-1, 2-5
----------------------------------	----------

Overvoltage	3-6, 7-2
--------------------------	----------

P

PELV	2-10, 6-4
-------------------	-----------

Phase Loss	8-4
-------------------------	-----

Power

Connections.....	2-6
Factor.....	1-5, 2-7, 3-2

Programming	1-4, 2-14, 3-6, 4-2, 5-4, 5-12, 8-4, 4-1, 4-4
--------------------------	---

Q

Quick Menu	4-2, 5-1, 5-4, 4-2
-------------------------	--------------------

R

Ramp-down Time	3-6
-----------------------------	-----

Ramp-up Time	3-6
---------------------------	-----

RCD..... 2-6

Reference..... 0-i, 4-2, 6-1, 7-2, 7-3

Relay Outputs..... 2-12

Remote
 Commands..... 1-4
 Programming..... 5-12
 Reference..... 7-2

Reset..... 4-1, 4-5, 7-3, 8-1, 8-5, 8-9, 4-3

RFI Filter..... 2-10

RMS Current..... 1-5

RS-485..... 2-15

Run
 Command..... 3-7
 Permissive..... 7-2

S

Safety Inspection..... 3-1

Serial Communication..... 1-4, 2-3, 2-11, 2-13, 4-3, 7-1, 7-2, 7-3, 8-1

Setpoint..... 7-3

Set-up..... 3-7, 4-2

Shielded
 Cable..... 2-1, 2-5, 3-2
 Wire..... 2-5

Short Circuit..... 8-6

Sleep Mode..... 7-3

Specifications..... 1-4, 2-2

Speed Reference..... 2-14, 3-7, 5-2, 6-0, 6-1

Start-up..... 1-4, 4-5, 5-1

Status Mode..... 7-1

Stop Command..... 7-2

Supply Voltage..... 2-10, 2-11, 3-1, 8-7

Switching Frequency..... 7-2

Symbols..... 0-i

System Feedback..... 1-4

T

Temperature Limits..... 3-2

Terminal
 53..... 2-14, 5-1, 5-2
 54..... 2-14
 Programming..... 2-14

Thermistor
 Thermistor..... 2-10, 6-4
 Control Wiring..... 2-10

Tightening Of Terminals..... 10-21

Torque Limit..... 3-6

Transient Protection..... 1-5

Trip
 Trip..... 8-1
 Function..... 2-5
 Lock..... 8-1

Troubleshooting..... 1-4

Type Code String (T/C)..... 1-6

U

UL Fuses..... 10-19

Uploading Data To The LCP..... 4-4

V

Voltage
 Imbalance..... 8-4
 Level..... 10-12

W

Wire Sizes..... 2-6, 2-7



www.trane.com

For more information, contact your local Trane office or e-mail us at comfort@trane.com

Literature Order Number	BAS-SVX19D-EN
Date	June 2013
Supersedes	May 2010

Trane has a policy of continuous product and product data improvement and reserves the right to change design and specifications without notice.

