



Aquavar[®] Intelligent Pump Controller - 150 HP to 600 HP

Table of Contents

1 Introduction and Safety.....	4
1.1 Introduction.....	4
1.1.1 Qualified personnel.....	4
1.2 Safety.....	4
1.2.1 Safety message levels.....	5
1.3 User safety.....	5
1.3.1 Electrical shock hazard.....	7
1.3.2 Discharge time.....	7
1.4 Protecting the environment.....	7
2 Transportation and Storage.....	9
2.1 Inspect the delivery.....	9
2.1.1 Inspect the package.....	9
2.1.2 Inspect the unit.....	9
2.2 System lifting.....	9
2.3 Transportation guidelines.....	9
2.4 Storage guidelines.....	9
3 Product Description.....	11
3.1 Product overview.....	11
3.2 Motor thermal protection.....	12
3.3 Dimensions.....	16
3.4 Description.....	23
3.5 Internal frequency converter controller functions.....	24
4 Mechanical Installation.....	25
4.1 Pre-installation.....	25
4.1.1 Installation site checklist.....	25
4.1.2 Frequency converter and motor pre-installation check list.....	25
4.1.3 General considerations.....	25
4.1.4 How to get started.....	26
4.1.5 Cooling.....	27
4.1.6 Lifting.....	27
4.1.7 Terminal and connection.....	28
4.1.8 Gland/Conduit entry IP21 (NEMA 1) and IP54 (NEMA12).....	34
4.1.9 NEMA-3R cover kit.....	35
4.1.10 Install the top plate.....	36
4.1.11 Install the gland plate.....	37
4.1.12 Install the NEMA 3R cover.....	38
5 Electrical Installation.....	40
5.1 Precautions.....	40
5.2 Basic electrical connection.....	41
5.3 Power connections.....	43
5.4 Power and control wiring for unshielded cables.....	50
5.5 Grounding.....	51
5.6 Extra protection (RCD).....	51
5.7 Torque.....	51
5.8 Shielded cables.....	52
5.9 Motor connection.....	52

5.10	Shielding against electrical noise.....	54
5.11	AC line input connections.....	54
5.12	External fan supply.....	55
5.13	Fuses and line power disconnectors.....	55
5.14	Motor insulation and motor bearing currents.....	56
5.15	Control terminals.....	57
5.15.1	Control cable routing.....	57
5.15.2	Access to control terminals.....	58
5.15.3	Control cable and connection.....	58
5.16	Control terminal types.....	60
5.17	Wiring to control terminals.....	63
5.17.1	Unplug terminal connectors.....	63
5.17.2	Control terminal connections.....	63
5.17.3	Control terminal functions.....	65
5.17.4	Analog input 53.....	65
5.17.5	Jumper terminals 12 and 18.....	65
5.17.6	Serial communication.....	65
5.18	Common terminal wiring configurations.....	66
5.19	Local control panel.....	75
5.20	Final set-up and test.....	83
6	Operation.....	86
6.1	Pre-start procedure.....	86
6.2	Pre-startup inspections.....	86
6.3	Apply power.....	87
6.4	Discharge time.....	87
6.5	Frequency converter programming.....	88
6.5.1	Programming the controller.....	88
6.5.2	Setup and commissioning.....	93
6.5.3	Pump protection setup.....	109
6.5.4	Digital input setup.....	116
6.5.5	Relay and analog output setup.....	119
6.5.6	Communication setup.....	123
6.5.7	Automatic motor adaptation.....	124
6.6	Basic operational programming.....	125
6.7	Induction motor setup.....	126
6.8	PM motor setup.....	126
6.9	Check motor rotation.....	128
6.10	Local-control test.....	128
6.11	System start-up.....	129
6.12	Acoustic noise or vibration.....	129
7	Warnings and alarms.....	130
7.1	System monitoring.....	130
7.2	Warning and alarm types.....	130
7.3	Warning and alarm displays.....	131
7.4	Warnings and alarms.....	139
8	Troubleshooting.....	147
8.1	Start up and operation troubleshooting.....	147
9	Technical Specification.....	150
9.1	Power-dependent specifications.....	150
9.2	General technical data.....	153
9.3	Fuse tables.....	159
9.4	Wire sizing charts.....	162
9.5	Parameter list.....	164

10 Product warranty..... 168

1 Introduction and Safety

1.1 Introduction

Purpose of this manual

The purpose of this manual is to provide necessary information for:

- Installation
- Operation
- Maintenance



CAUTION:

Read this manual carefully before installing and using the product. Improper use of the product can cause personal injury and damage to property, and may void the warranty.

NOTICE:

Save this manual for future reference, and keep it readily available at the location of the unit.

1.1.1 Qualified personnel



WARNING:

This product is intended to be operated by qualified personnel only.

- Correct and reliable transport, storage, installation, operation, and maintenance are required for the trouble-free and safe operation of the frequency converter. Only qualified personnel are allowed to install or operate this equipment.
- Qualified personnel are defined as trained staff, who are authorized to install, commission, and maintain equipment, systems, and circuits in accordance with pertinent laws and regulations. Also, the personnel must be familiar with the instructions and safety measures that are described in this document.

1.2 Safety



WARNING:

- The operator must be aware of safety precautions to prevent physical injury.
 - Operating, installing, or maintaining the unit in any way that is not covered in this manual could cause death, serious personal injury, or damage to the equipment. This includes any modification to the equipment or use of parts not provided by Xylem. If there is a question regarding the intended use of the equipment, please contact a Xylem representative before proceeding.
 - Do not change the service application without the approval of an authorized Xylem representative.
-



CAUTION:

You must observe the instructions contained in this manual. Failure to do so could result in physical injury, damage, or delays.





1.2.1 Safety message levels

About safety messages

It is extremely important that you read, understand, and follow the safety messages and regulations carefully before handling the product. They are published to help prevent these hazards:

- Personal accidents and health problems
- Damage to the product
- Product malfunction

Definitions

Safety message level	Indication
 DANGER:	A hazardous situation which, if not avoided, will result in death or serious injury
 WARNING:	A hazardous situation which, if not avoided, could result in death or serious injury
 CAUTION:	A hazardous situation which, if not avoided, could result in minor or moderate injury
 Electrical Hazard:	The possibility of electrical risks if instructions are not followed in a proper manner
NOTICE:	<ul style="list-style-type: none"> • A potential situation which, if not avoided, could result in undesirable conditions • A practice not related to personal injury

1.3 User safety

General safety rules

These safety rules apply:

- Always keep the work area clean.
- Pay attention to the risks presented by gas and vapors in the work area.
- Avoid all electrical dangers. Pay attention to the risks of electric shock or arc flash hazards.
- Always bear in mind the risk of drowning, electrical accidents, and burn injuries.

Safety equipment

Use safety equipment according to the company regulations. Use this safety equipment within the work area:

- Hard hat
- Safety goggles, preferably with side shields
- Protective shoes
- Protective gloves
- Gas mask
- Hearing protection

- First-aid kit
- Safety devices

NOTICE:

Never operate a unit unless safety devices are installed. Also see specific information about safety devices in other chapters of this manual.

Electrical connections

Electrical connections must be made by certified electricians in compliance with all international, national, state, and local regulations. For more information about requirements, see sections dealing specifically with electrical connections.

Precautions before work

Observe these safety precautions before you work with the product or are in connection with the product:

- Provide a suitable barrier around the work area, for example, a guard rail.
- Make sure that all safety guards are in place and secure.
- Make sure that you have a clear path of retreat.
- Make sure that the product cannot roll or fall over and injure people or damage property.
- Make sure that the lifting equipment is in good condition.
- Use a lifting harness, a safety line, and a breathing device as required.
- Allow all system and pump components to cool before you handle them.
- Make sure that the product has been thoroughly cleaned.
- Disconnect and lock out power before you service the pump.
- Check the explosion risk before you weld or use electric hand tools.

Precautions during work

Observe these safety precautions when you work with the product or are in connection with the product:

- Never work alone.
- Always wear protective clothing and hand protection.
- Stay clear of suspended loads.
- Always lift the product by its lifting device.
- Beware of the risk of a sudden start if the product is used with an automatic level control.
- Beware of the starting jerk, which can be powerful.
- Rinse the components in water after you disassemble the pump.
- Do not exceed the maximum working pressure of the pump.
- Do not open any vent or drain valve or remove any plugs while the system is pressurized. Make sure that the pump is isolated from the system and that pressure is relieved before you disassemble the pump, remove plugs, or disconnect piping.
- Never operate a pump without a properly installed coupling guard.

Wash the skin and eyes

Follow these procedures for chemicals or hazardous fluids that have come into contact with your eyes or your skin:

Condition	Action
Chemicals or hazardous fluids in eyes	<ol style="list-style-type: none"> 1. Hold your eyelids apart forcibly with your fingers. 2. Rinse the eyes with eyewash or running water for at least 15 minutes. 3. Seek medical attention.

Condition	Action
Chemicals or hazardous fluids on skin	<ol style="list-style-type: none"> 1. Remove contaminated clothing. 2. Wash the skin with soap and water for at least 1 minute. 3. Seek medical attention, if necessary.

1.3.1 Electrical shock hazard



Electrical Hazard:

Frequency converters contain dangerous voltages when connected to mains voltage. Improper installation, and installing or servicing with power connected, can cause death, serious injury, or equipment failure.

To avoid death, serious injury, or equipment failure:

- Only use qualified electricians for the installation.
- Disconnect the frequency converter from all power sources before installation or service.
- Treat the bus bar and heat sink as live whenever the unit has mains voltage connected (including when the frequency converter is tripped or waiting for a command).
- Follow the guidelines in these instructions and local electrical safety codes.

1.3.2 Discharge time



WARNING:

The frequency converter contains DC-link capacitors, which can remain charged even when the frequency converter is not powered. High voltage can be present even when the frequency converter is not powered. High voltage can be present even when the warning LED indicator lights are off. Failure to wait the specified time after power has been removed before performing service or repair work can result in death or serious injury.

- Stop motor.
- Disconnect AC mains and remote DC-link power supplies, including battery back-ups, UPS, and DC-link connections to other frequency converters.
- Disconnect or lock PM motor.
- Wait for the capacitors to discharge fully. The minimum duration of waiting time for all drives specified in the table below.
- Before performing any service or repair work, use an appropriate voltage measuring device to make sure that the capacitors are fully discharged.

Voltage (V)	Power range (HP)	Minimum waiting time (min)
380-480	150-350	20
380-480	450-600	40
525-690	150-400	20
525-690	450-600	30

1.4 Protecting the environment

Emissions and waste disposal

Observe the local regulations and codes regarding:

- Reporting of emissions to the appropriate authorities
- Sorting, recycling and disposal of solid or liquid waste
- Clean-up of spills

Exceptional sites



CAUTION: Radiation Hazard

Do NOT send the product to Xylem if it has been exposed to nuclear radiation, unless Xylem has been informed and appropriate actions have been agreed upon.

Recycling guidelines

Always follow local laws and regulations regarding recycling.

Waste and emissions guidelines

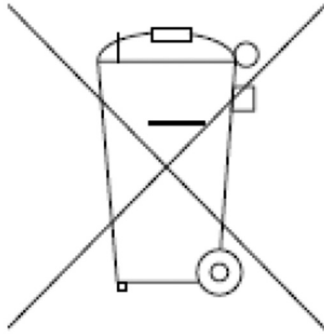

Do not dispose of equipment containing electrical components together with domestic waste. Collect it separately in accordance with local and currently valid legislation.

2 Transportation and Storage

2.1 Inspect the delivery

2.1.1 Inspect the package

1. Inspect the package for damaged or missing items upon delivery.
2. Note any damaged or missing items on the receipt and freight bill.
3. File a claim with the shipping company if anything is out of order.
If the product has been picked up at a distributor, make a claim directly to the distributor.

2.1.2 Inspect the unit

1. Remove packing materials from the product.
Dispose of all packing materials in accordance with local regulations.
2. Inspect the product to determine if any parts have been damaged or are missing.
3. If applicable, unfasten the product by removing any screws, bolts, or straps.
For your personal safety, be careful when you handle nails and straps.
4. Contact the local sales representative if there is any issue.

2.2 System lifting



WARNING:

Assembled units and their components are heavy. Failure to properly lift and support this equipment can result in serious physical injury and/or equipment damage. Lift equipment only at the specifically identified lifting points. Lifting devices such as eyebolts, slings, and spreaders must be rated, selected, and used for the entire load being lifted.



WARNING: Crush Hazard

1) Always lift the unit by its designated lifting points. 2) Use suitable lifting equipment and ensure that the product is properly harnessed. 3) Wear personal protective equipment. 4) Stay clear of cables and suspended loads.

2.3 Transportation guidelines

Precautions



DANGER: Crush Hazard

Moving parts can entangle or crush. Always disconnect and lock out power before servicing to prevent unexpected startup. Failure to do so could result in death or serious injury.

2.4 Storage guidelines

Storage location

The product must be stored in a covered and dry location free from heat, dirt, and vibrations.

NOTICE:

Protect the product against humidity, heat sources, and mechanical damage.

NOTICE:

Do not place heavy weights on the packed product.

3 Product Description

3.1 Product overview

A frequency converter is an electronic motor controller that converts AC mains input into DC and then into a variable voltage, variable frequency output waveform. The following is a list of functions of the frequency converter:

- Regulates the frequency and voltage to control the motor speed or torque.
- Varies the speed of the motor in response to system feedback, such as changing temperature or pressure for controlling fan, compressor, or pump motors.
- Regulates the motor by responding to remote commands from external controls.
- Monitors the system and motor status.
- Issues warnings or alarms for fault conditions.
- Starts and stops the motor.
- Optimizes energy efficiency.

Operation and monitoring functions are available as status indications to an outside control system or serial communication network.

Approvals and certifications



The unit complies with UL508C thermal memory retention requirements.

Abbreviations and standards

Abbreviation	Term	SI unit	I-P unit
a	Acceleration	m/s ²	ft/s ²
AWG	American wire gauge		
Auto Tune	Automatic Motor Tuning		
°C	Celsius		
I	Current	A	Amp
I _{LIM}	Current limit		
Joule	Energy	J = N·m	ft-lb, Btu
°F	Fahrenheit		
FC	Adjustable Frequency Drive		
f	Frequency	Hz	Hz
kHz	Kilohertz	kHz	kHz
LCP Local Control Panel			
mA	Milliampere		
ms	millisecond		
min	Minute		
MCT	Motion Control Tool		
M-TYPE	Motor Type Dependent		
Nm	Newton meters		in-lbs
I _{M,N}	Nominal motor current		
F _{M,N}	Nominal motor frequency		
P _{M,N}	Nominal motor power		
U _{M,N}	Nominal motor voltage		

Abbreviation	Term	SI unit	I-P unit
par.	Parameter		
PELV	Protective Extra Low Voltage		
Watt	Power	W	Btu/hr, hp
Pascal	Pressure	Pa = N/m ²	psi, psf, ft of water
I _{INV}	Rated Inverter Output Current		
RPM	Revolutions per minute		
SR	Size related		
T	Temperature	C	F
t	Time	s	s, hr
T _{LIM}	Torque limit		
U	Voltage	V	V

3.2 Motor thermal protection

Motor thermal protection can be implemented using various techniques: PTC sensor in motor windings, mechanical thermal switch, (Klixon type) or Electronic Thermal Relay (ETR).

Protection against motor overheating comes from 1-90 Motor Thermal Protection. If the ETR function is desired, set 1-90 Motor Thermal Protection to data value [4] ETR trip (default value) or data value [3] ETR warning.

NOTICE: The ETR function is initialized at 1.16 x rated motor current and rated motor frequency. The ETR function provides class 20 motor overload protection in accordance with the NEC.

Motor thermal protection prevents the motor from overheating. The ETR function is an electronic feature that simulates a bimetal relay that is based on internal measurements. The characteristic is shown in the following figure.

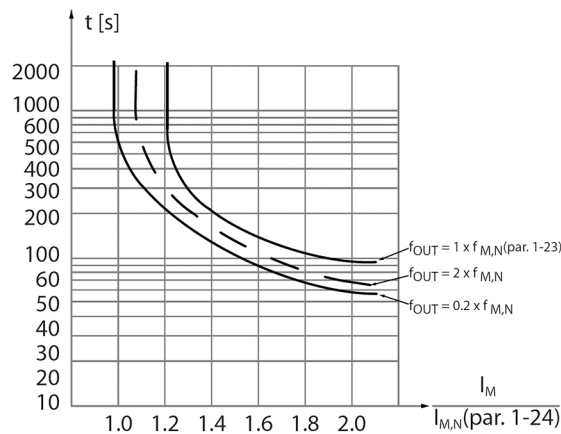

Figure 1: The characteristics of ETR function

The X-axis shows the ratio between I_{motor} actual and I_{motor} nominal. The Y-axis shows the time in seconds before the ETR cuts off and trips the frequency converter. The curves show the characteristic nominal speed, at twice the nominal speed and at 20% of the nominal speed. The curve shows that at lower speed the ETR cuts off at lower heat due to less cooling of the motor. In that way, the motor is protected from overheating even at low speed. The ETR function calculates the motor temperature that is based on actual current and speed. The calculated temperature is visible as a readout parameter in 16-18 Motor Thermal in the frequency converter.

Motor thermal protection can also be achieved using an external thermistor. Set 1-90 Motor Thermal Protection to data value [2] Thermistor trip or data value [1] Thermistor warning. Set 1-93 Thermistor Source to the input to which the thermistor is connected. Refer to the examples below for wiring details.

The thermistor cut-out value is $>3k\Omega$. Integrate a thermistor (PTC sensor) in the motor for winding protection.

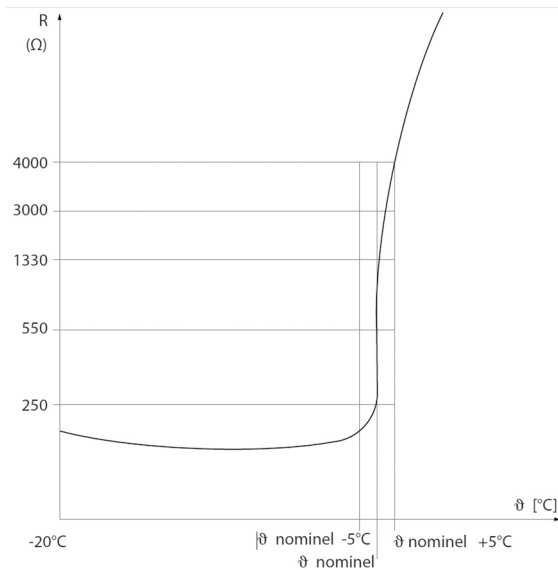
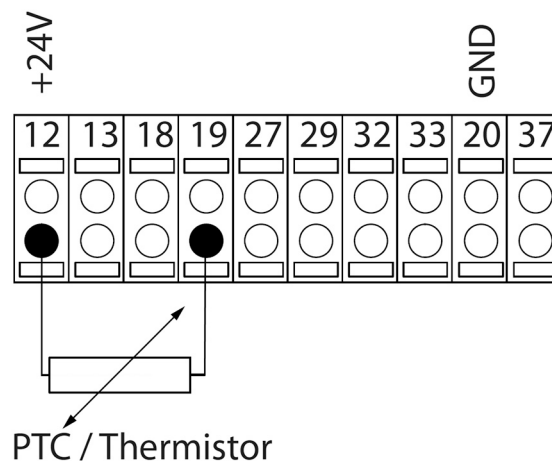

Figure 2: The characteristics of Thermistor resistant

The following examples show various ways to connect the PTC/Thermistor to the drive.

- Using a digital input and the 24V as a power supply.
 - Parameter set-up:
 - Set 1-90 Motor Thermal Protection to Thermistor Trip [2]
 - Set 1-93 Thermistor Source to Digital Input 19 [4]



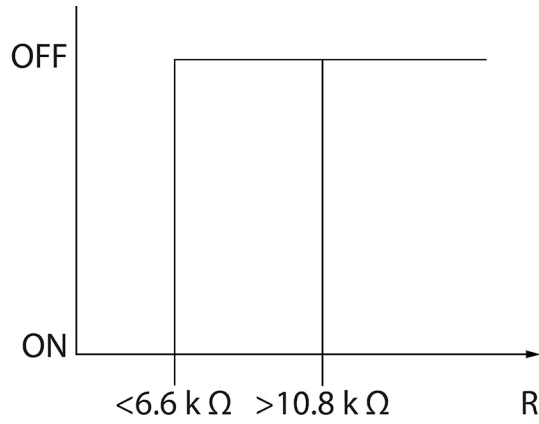

Figure 3: ON/OFF with a digital input and the 24V as a power supply

- Using a digital input and the 10V as a power supply.
 - Parameter set-up:
 - Set 1-90 Motor Thermal Protection to Thermistor Trip [2]
 - Set 1-93 Thermistor Source to Digital Input 19 [4]

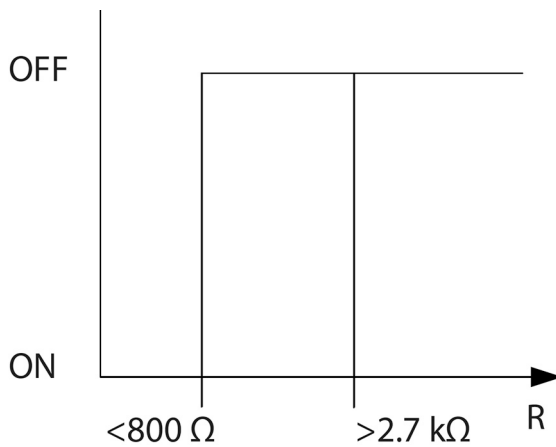
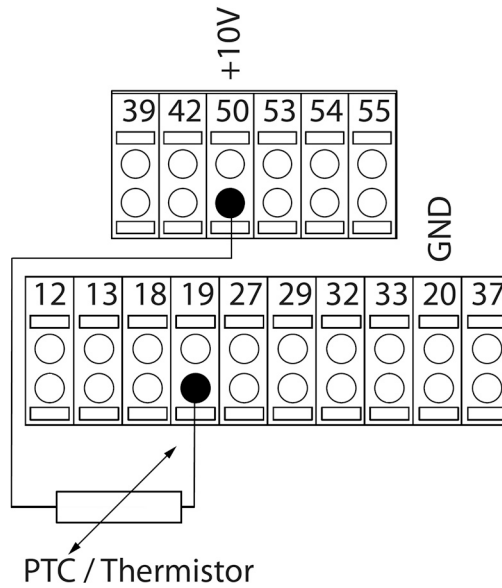

Figure 4: ON/OFF with a digital input and the 10V as a power supply

- Using an analog input and 10V as a power supply
 - Parameter set-up:

- Set 1-90 Motor Thermal Protection to Thermistor Trip [2]
- Set 1-93 Thermistor Source to Analog Input 54 [2]. Do not use Analog Input 54 as any other feedback or reference source. Be sure to configure the analog input configuration switches properly.

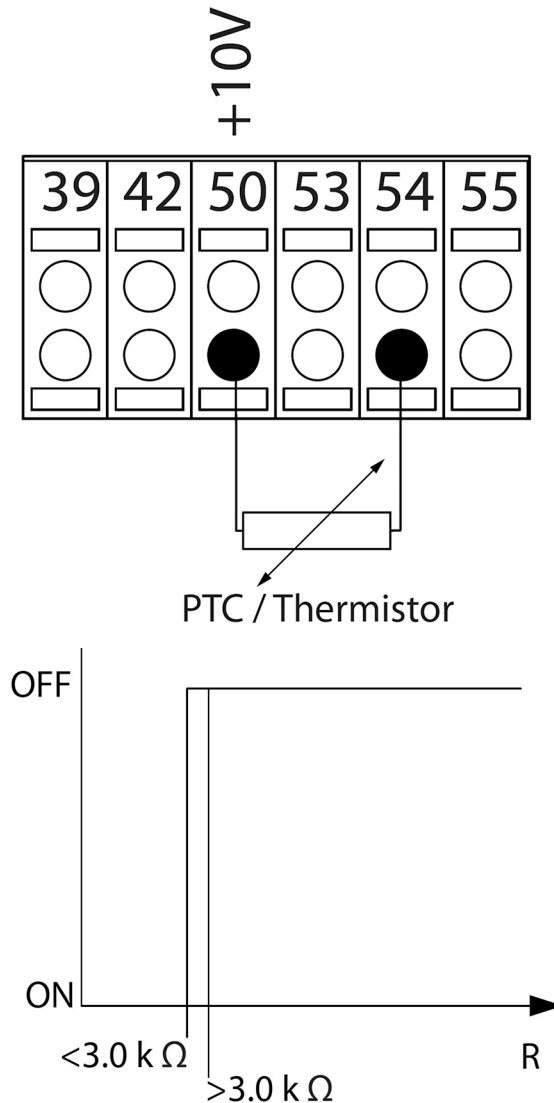

Figure 5: ON/OFF with an analog input and 10V as a power supply

NOTE: Check that the chosen supply voltage follows the specification of the thermistor element.

Summary

Input Digital/analog	Supply Voltage V Cut-out Values	Threshold Cut-out Values
Digital	24	< 6.6kΩ - > 10.8kΩ
Digital	10	< 800kΩ - > 2.7kΩ
Analog	10	< 3.0kΩ - > 3.0kΩ

With the Torque limit feature the motor is protected from being overloaded independent of the speed. With the ETR the motor is protected from being overheated and there is no need for any further motor protection. That means when the motor is heated up the ETR timer controls how long the motor can be operated at the high temperature before it is stopped in order to prevent overheating. If the motor is overloaded without reaching the

temperature where the ETR turns off the motor, the torque limit will protect the motor from being overloaded.

The ETR function is activated in 1-90 Motor Thermal Protection and is controlled in 4-16 Torque Limit Motor Mode. The time before the torque limit warning trips the drive is set in 14-25 Trip Delay at Torque Limit.

3.3 Dimensions

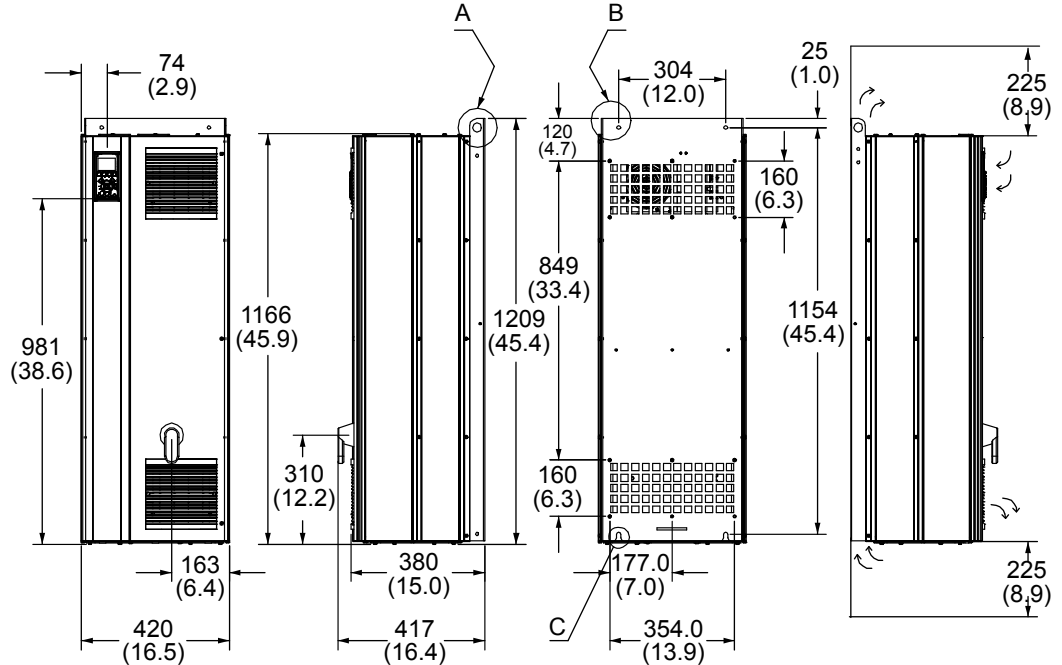

Figure 6: D1 enclosure, cabinet mount

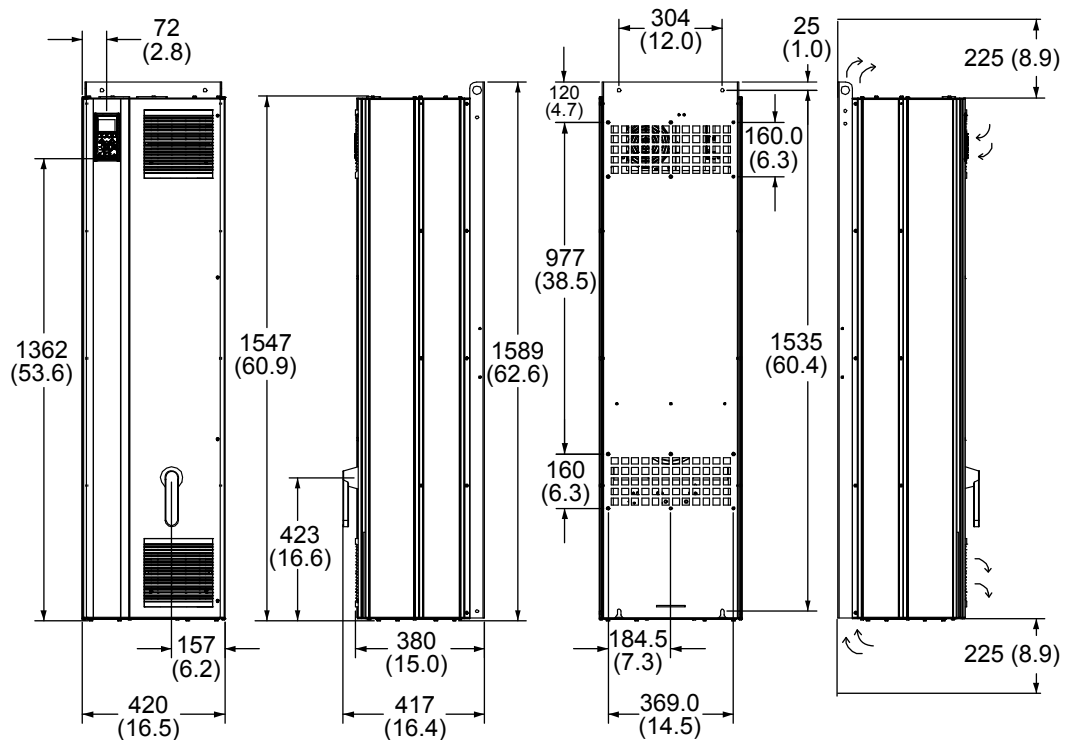

Figure 7: D2 enclosure, cabinet mount

Please note airflow directions

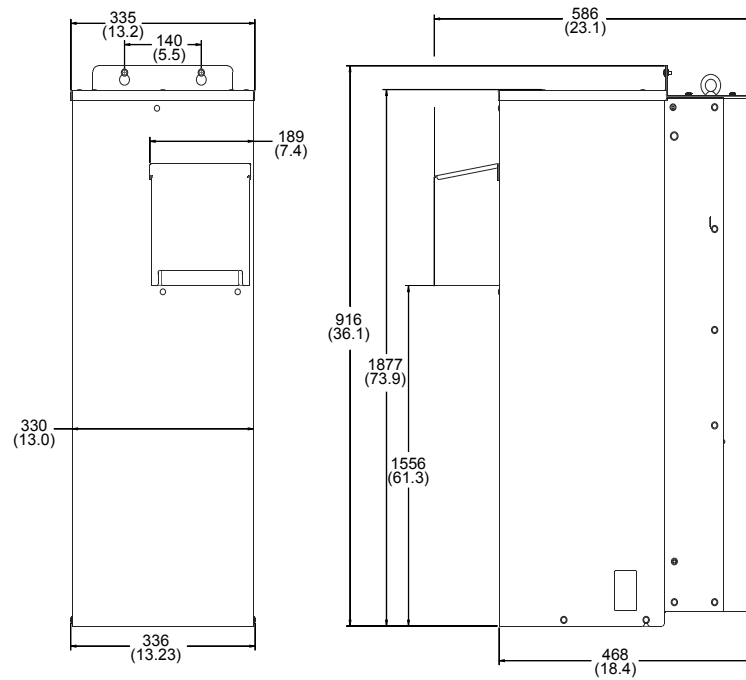

Figure 8: Exterior dimensions for D1h with NEMA 3R Kit (9K715)

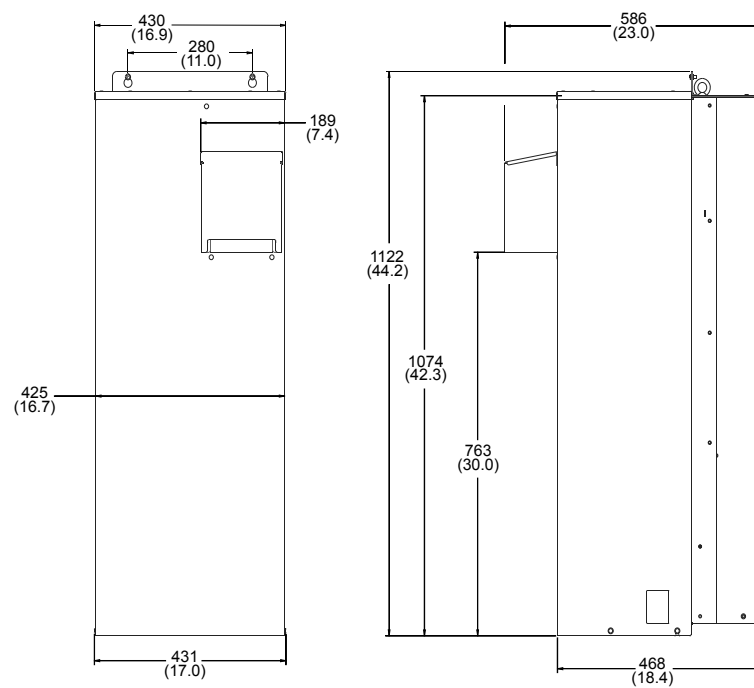

Figure 9: Exterior dimensions for D2h with NEMA 3R Kit (9K716)

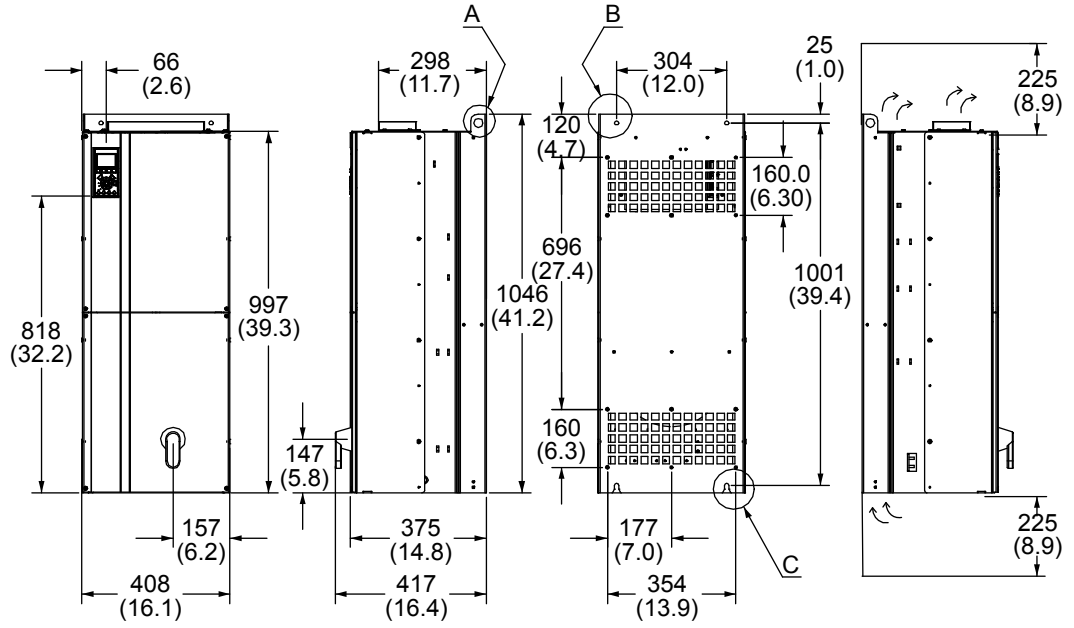

Figure 10: D3 enclosure, cabinet mount

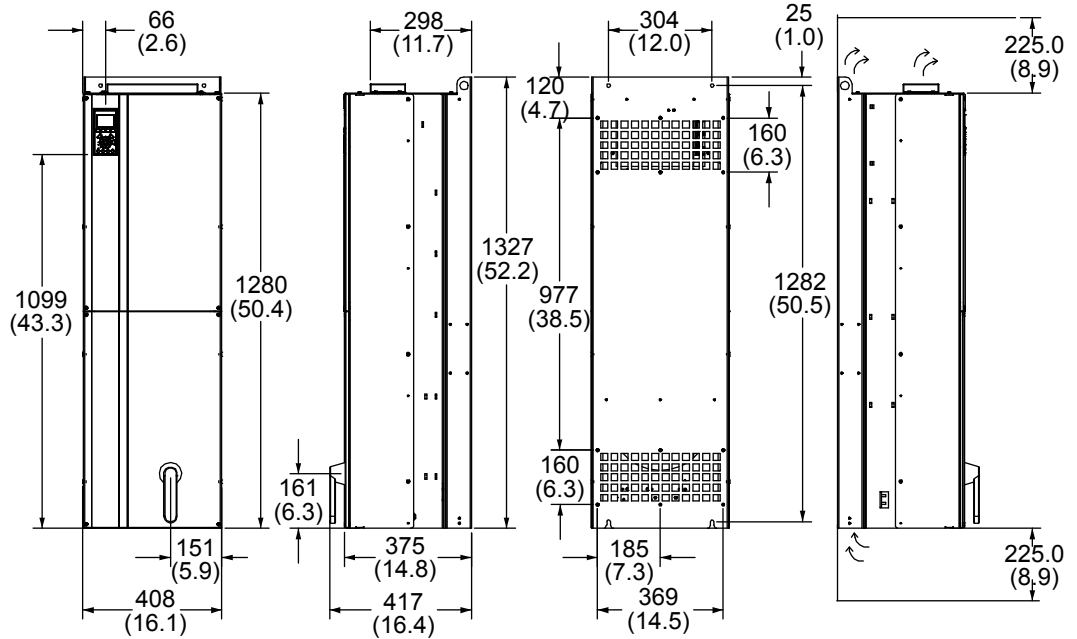

Figure 11: D4 enclosure, cabinet mount

Please note airflow directions

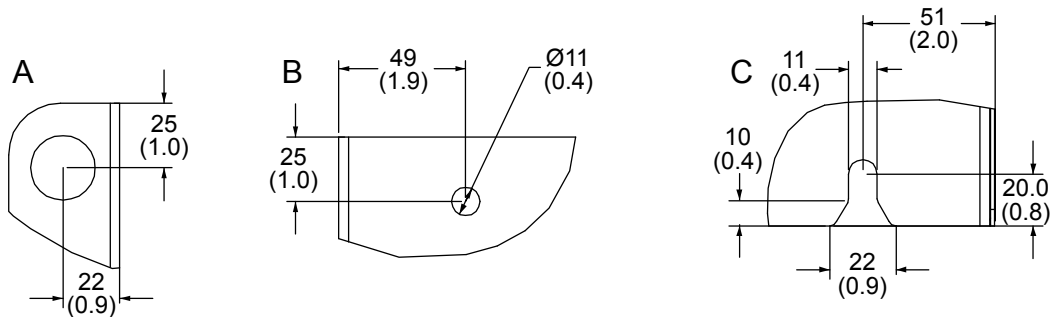

Figure 12: IP00/IP21/IP54 – all sizes

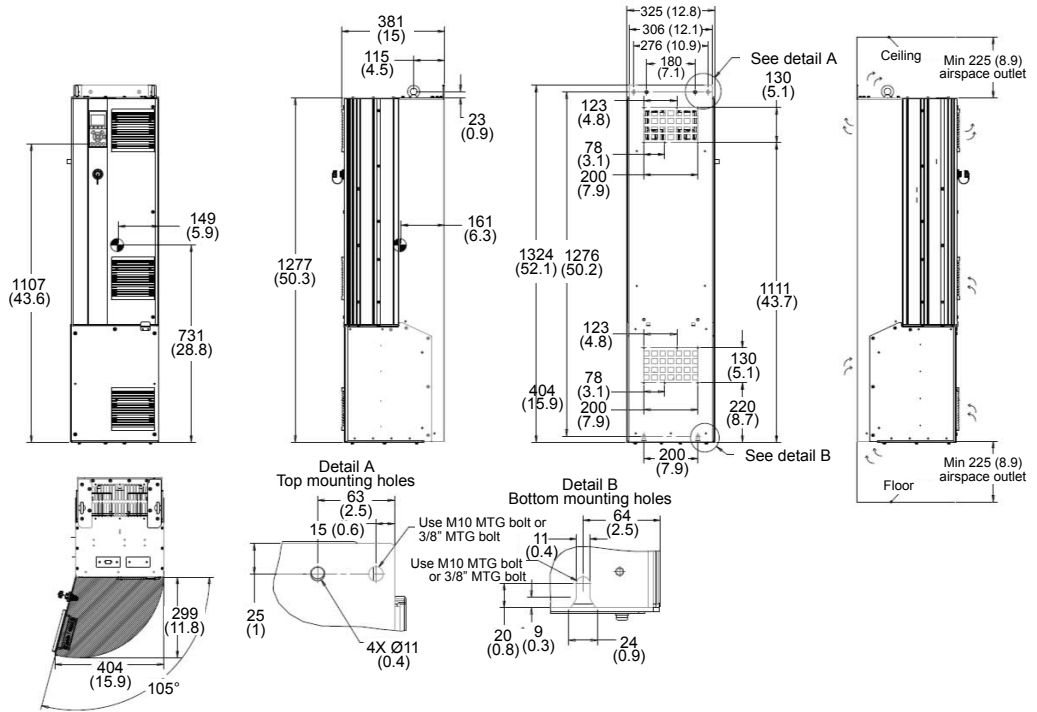

Figure 13: D5 Enclosure

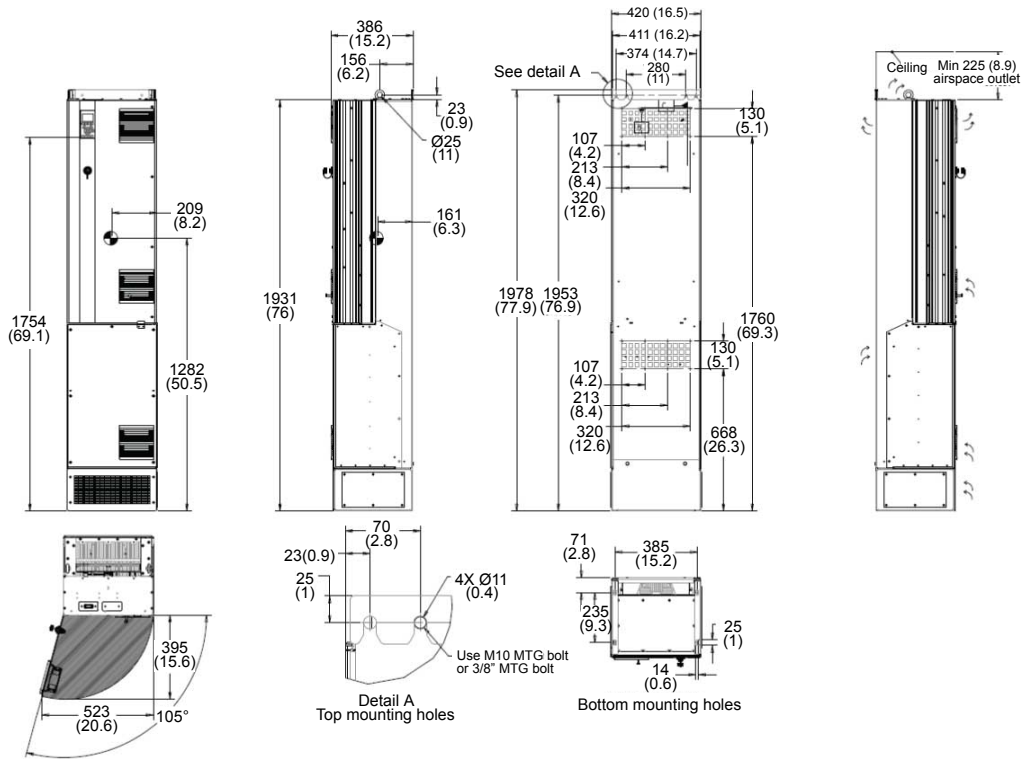

Figure 14: D7 Enclosure

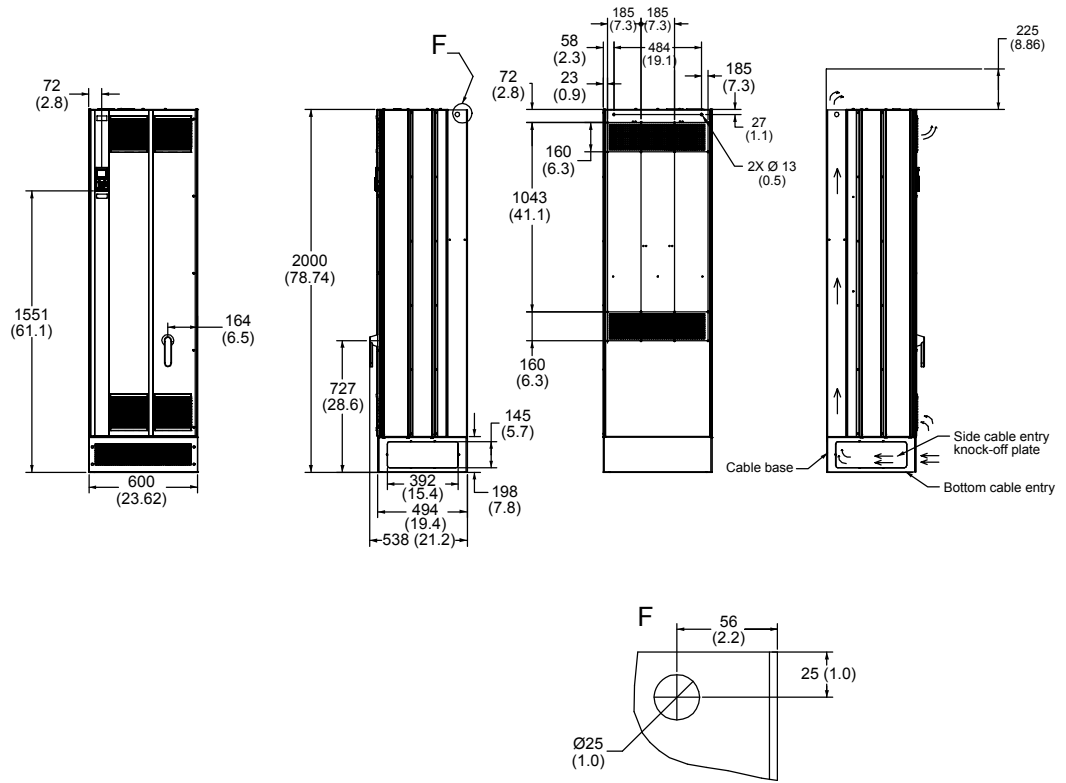

Figure 15: E1 Enclosure, floor- or cabinet-mount

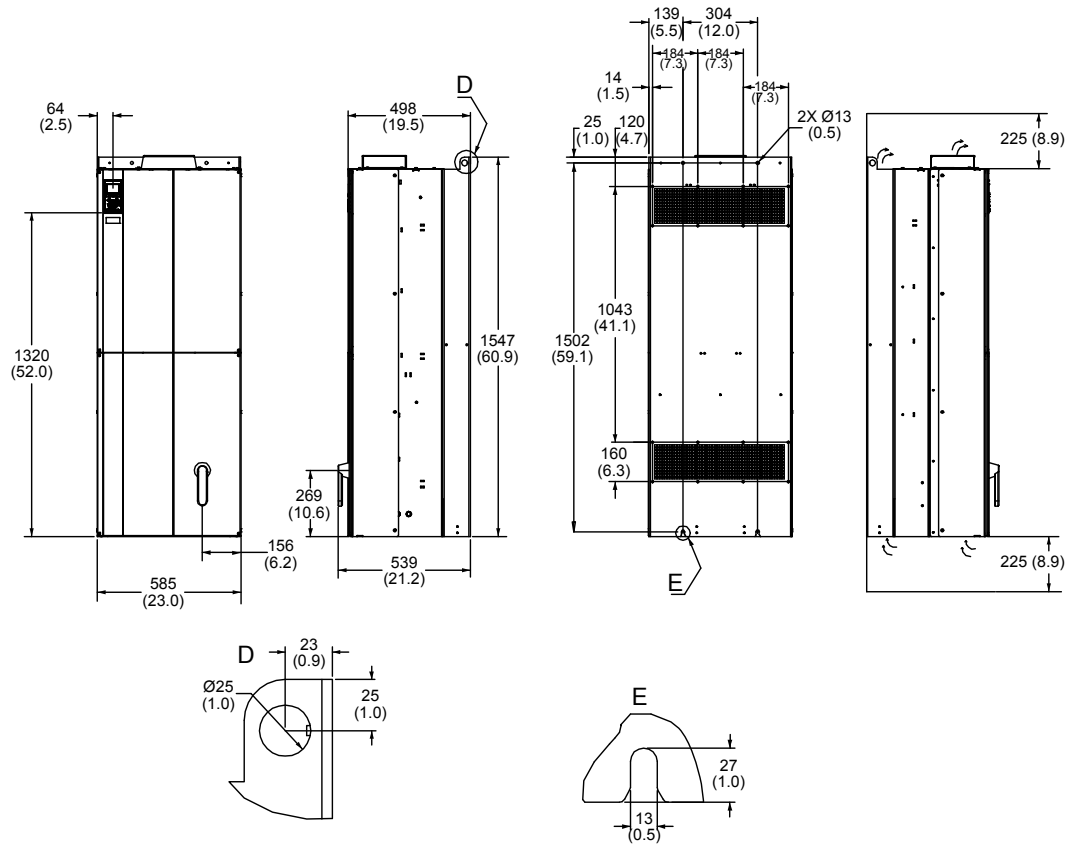

Figure 16: E2 Enclosure, floor- or cabinet-mount

Table 1: Mechanical dimensions and rated power for D1, D2, D3, D4

Frame size		D1	D2	D3	D4
Normal overload rated power 110% overload torque		150–250 HP (110–160 kW) at 400 V	300–450 HP (200–315 kW) at 400 V	150–250 HP (110–160 kW) at 400 V (380–480 V)	300–450 HP (200–315 kW) at 400 V
		150–200 HP (132–160 kW) at 690 V (525–690 V)	250–400 HP (200–400 kW) at 690 V (525–690 V)	150–200 HP (132–160 kW) at 400 V (380–480 V)	250–400 HP (200–400 kW) at 690 V (525–690 V)
Enclosure protection	IP	21/54		00	
	NEMA	Type 1/Type 12		Chassis	
Shipping Dimension in. (mm)	Height	23.11 (587)			
	Width	39.25 (997)	46.06 (1170)	39.25 (997)	46.06 (1170)
	Depth	18.11 (460)	21.06 (535)	18.11 (460)	21.06 (535)
Drive dimension in. (mm)	Height	47.6 (1209)	62.56 (1589)	41.18 (1046)	52.24 (1327)
	Width	16.54 (420)		16.06 (408)	
	Depth	14.96 (380)		14.76 (375)	
Max. Weight lbs (kg)		229.3 (104)	332.9 (151)	200.62 (91)	304.24 (138)









Frame Size		D1	D2	D3	D4
					
Enclosure protection	IP	21/54		00	
	NEMA	Type 1 / Type 12		Chassis	
Normal overload rated power – 110% overload torque		150–250 HP (110–160 kW) at 400 V (380–480 V)	300–450 HP (200–315 kW) at 400 V	150–250 HP (110–160 kW) at 400 V (380–480 V)	300–450 HP (200–315 kW) at 400 V
		150–200 HP (132–160 kW) at 400 V (380–480 V)	250–400 HP (200–400 kW) at 690 V (525–690 V)	150–200 HP (132–160 kW) at 400 V (380–480 V)	250–400 HP (200–400 kW) at 690 V (525–690 V)

Table 2: Mechanical dimensions and rated power for D5, D7, E1, E2

Frame size		D5	D7	E1	E2
Normal overload rated power 110% overload torque		150–250 HP (110–160 kW) at 400 V (380–480 V)	300–450 HP (200–315 kW) at 400 V	500–600 HP (355–450 kW) at 400 V (380–480 V)	
		150–200 HP (132–160 kW) at 400 V (380–480 V)	250–400 HP (200–400 kW) at 690 V (525–690 V)	450–600 HP (450–560 kW) at 690 V (525–690 V)	
Enclosure protection	IP	21/54	00	21/54	00
	NEMA	Type 1/Type 12	Chassis	Type 1/Type 12	Chassis

Frame size		D5	D7	E1	E2
Shipping dimensions in. (mm)	Height	25.98 (660)		31.65 (840)	32.72 (831)
	Width	71.65 (1820)	97.24 (2470)	86.5 (2197)	67.13 (1705)
	Depth	20.08 (510)	23.23 (590)	28.98 (736)	
Drive dimensions in. (mm)	Height	52.13 (1324)	77.87 (1978)	78.74 (2000)	60.91 (1547)
	Width	12.8 (325)	16.54 (420)	23.62 (600)	23 (585)
	Depth	15 (381)	15.2 (386)	18.45 (494)	9.61 (498)
Max. Weight lbs (kg)		255 (116)	440 (200)	690 (313)	611 (277)

Frame size		D5	D7	E1	E2
					
Enclosure protection	IP	00		21/54	00
	NEMA	Chassis		Type 1/Type 12	Chassis
Normal overload rated power – 110% overload torque		150–250 HP (110–160 kW) at 400 V (380–480 V) 150–200 HP (132–160 kW) at 400 V (380–480 V)	300–450 HP (200–315 kW) at 400 V 250–400 HP (200–400 kW) at 690 V (525–690 V)	500–600 HP (355–450 kW) at 400 V (380–480 V) 450–600 HP (450–560 kW) at 690 V (525–690 V)	

NOTE:

- The typical power loss is at nominal load conditions and expected to be within ±15% (tolerance relates to variety in voltage and cable conditions).
- The losses are based on the default switching frequency. The losses increase significantly at higher switching frequencies.
- D5h-D8h frames for IP21 and IP54 are based upon D1h and D2h ratings added with the options cabinet for disconnect and fuse respectively, shown in the following table.
- The NEMA 3R cover kit is for D1h and D2h enclosure.

Table 3: D5h-D8h frames

Frame size	Description	Max. weight, kg (lbs)
D5h	D1h ratings+disconnect and/or brake chopper	116 (255)
D6h	D1h ratings+contactor and/or circuit breaker	129 (285)
D7h	D2h ratings+disconnect and/or brake chopper	200 (440)
D8h	D2h ratings+contactor and/or circuit breaker	225 (496)

3.4 Description

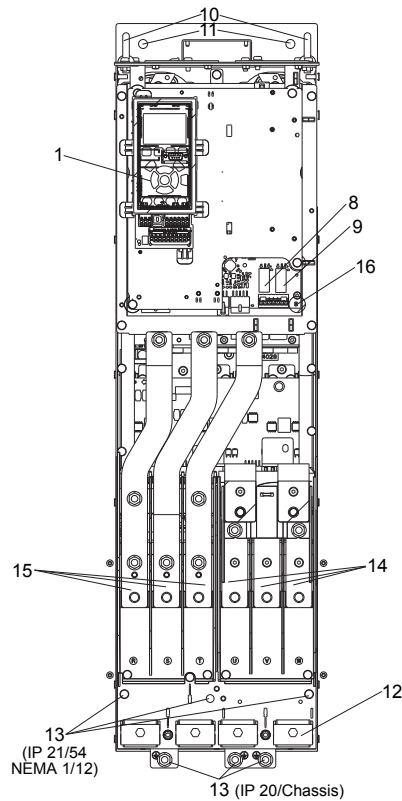

Figure 17: D1 Interior components

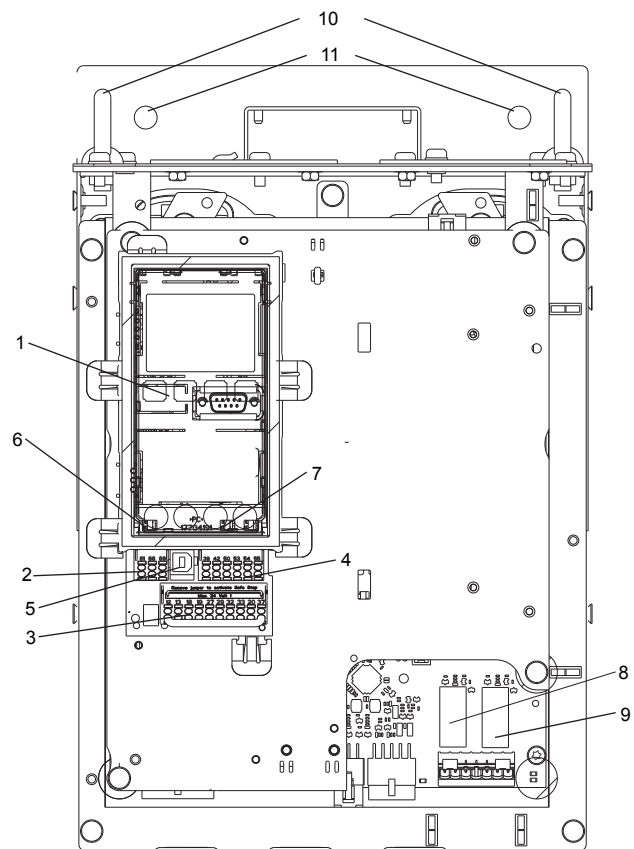

Figure 18: Close-up view: LCP and control functions

1	LCP
2	RS-485 serial bus connector
3	Digital I/O and 24 V power supply
4	Analog I/O connector
5	USB connector
6	Serial bus terminal switch
7	Analog switches (A53), (A54)
8	Relay 1 (01, 02, 03)
9	Relay 2 (04, 05, 06)
10	Lifting ring
11	Mounting slot
12	Cable clamp (PE)
13	Ground
14	Motor output terminals 96 (U), 97 (V), 98 (W)
15	Line power input terminals 91 (L1), 92 (L2), 93 (L3)
16	TB5 (IP21/54 only). Terminal block for anti-condensation heater.

For location of TB6 (terminal block for contactor), see Terminal Locations: D5h-D8h.

3.5 Internal frequency converter controller functions

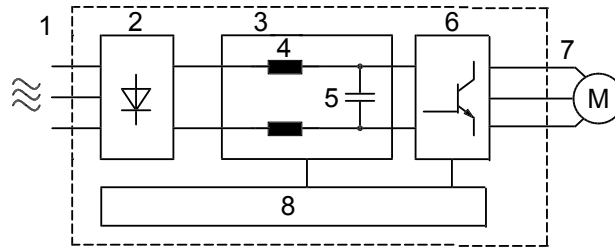

Figure 19: Frequency converter block diagram

Area	Title	Functions
1	Mains input	Three-phase AC mains power supply to the frequency converter
2	Rectifier	The rectifier bridge converts the AC input to DC current to supply inverter power.
3	DC bus	Intermediate DC-bus circuit handles the DC current
4	DC reactors	<ul style="list-style-type: none"> • Filter the intermediate DC circuit voltage • Provide line transient protection • Reduce RMS current • Raise the power factor reflected back to the line • Reduce harmonics on the AC input
5	Capacitor bank	<ul style="list-style-type: none"> • Stores the DC power • Provides ride-through protection for short power losses
6	Inverter	Converts the DC into a controlled PWM AC waveform for a controlled variable output to the motor.
7	Output to motor	Regulated three-phase output power to the motor
8	Control circuitry	<ul style="list-style-type: none"> • Input power, internal processing, output, and motor current are monitored to provide efficient operation and control. • User interface and external commands are monitored and performed. • Status output and control can be provided.

4 Mechanical Installation

4.1 Pre-installation

4.1.1 Installation site checklist

- The frequency converter relies on the ambient air for cooling. Observe the limitations on ambient air temperature for optimal operation.
- Ensure that the installation location has sufficient support strength to mount the frequency converter.
- Keep the manual, drawings, and diagrams accessible for detailed installation and operation instructions. It is important that the manual is available for equipment operators.
- Locate equipment as near to the motor as possible. Keep motor cables as short as possible. Check the motor characteristics for actual tolerances.
 - For installations with motor leads longer than 50 feet, use the output filter option to protect the motor.
- Ensure that the ingress protection rating of the frequency converter is suitable for the installation environment. IP55 (Type 3R/12) or IP66 (Type 4X) enclosures may be necessary.



CAUTION:

Ingress protection. IP54, IP55 (Type 3R/12) and IP66 (Type 4X) ratings can only be guaranteed if the unit is properly closed.

- Ensure all cable glands and unused holes for glands are properly sealed.
 - Ensure that the unit cover is properly closed. Do not leave the frequency converter uncovered.
 - For outdoor enclosures ensure that NEMA 3R drive units are properly covered with IPC NEMA 3R COVER. Part number 9K715 for D1 Frame and 9K716 for D2 Frame.
-

4.1.2 Frequency converter and motor pre-installation check list

- Compare the model number of the unit on the nameplate to what was ordered to verify the proper equipment.
- Ensure each of the following are rated for same voltage:
 - Mains (power)
 - Frequency converter
 - Motor
- Ensure that the frequency converter output current rating is equal to or greater than motor service factor current for peak motor performance.
 - Motor size and frequency converter power must match for proper overload protection.
 - If frequency converter rating is less than motor, full motor output cannot be achieved.

4.1.3 General considerations

Tools needed

To perform the mechanical installation, the following tools are needed:

- Drill with 0.39 or 0.47 in (10 or 12 mm) drill.
- Tape measure
- Wrench with relevant metric sockets (0.28-0.67 in (7-17 mm))

- Extensions to wrench
- Sheet metal punch for conduits or cable connectors in IP 21/NEMA 1 and IP 54 units
- Lifting bar to lift the unit (rod or tube max. Ø1 in (25 mm), able to lift minimum 880 lbs (400 kg).
- Crane or other lifting aid to place the frequency converter in position.
- A Torx T50 tool is needed to install the E1 in IP21 and IP54 enclosure types.

Space

Ensure proper space above and below the frequency converter to allow airflow and cable access. In addition, space in front of the unit must be considered to allow the panel door to be opened.

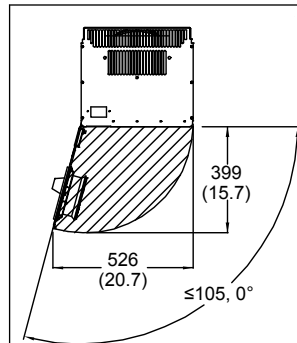

Figure 20: Space in front of IP21/IP54 enclosure type, frame size D1 and D2

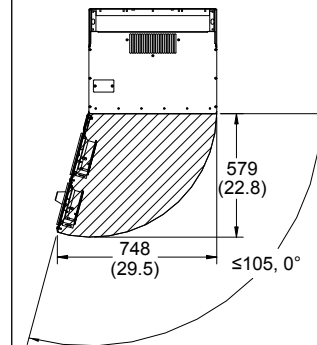

Figure 21: Space in front of IP21/IP54 enclosure type, frame size E1

Wire access

Ensure that proper cable access is present including the necessary bending allowance. As the IP00 enclosure is open to the bottom, cables must be fixed to the back panel of the enclosure where the frequency converter is mounted, for example, by using cable clamps.

NOTICE:

All cable lugs/shoes must mount within the width of the terminal bus bar.

4.1.4 How to get started

The frequency converter is designed for quick installation and is EMC-compliant. Just follow the steps described below.



CAUTION:

Read this manual carefully before installing and using the product. Improper use of the product can cause personal injury and damage to property, and may void the warranty.

Mechanical installation

- Mechanical mounting

Electrical installation

- Connection to Line and Protecting Ground
- Motor connection and cables
- Fuses and circuit breakers
- Control terminals cables

Quick setup

- Local Control Panel, LCP
- Automatic Motor Adaptation, AMA
- Programming

Frame size is depending on enclosure type, power range and AC line voltage.

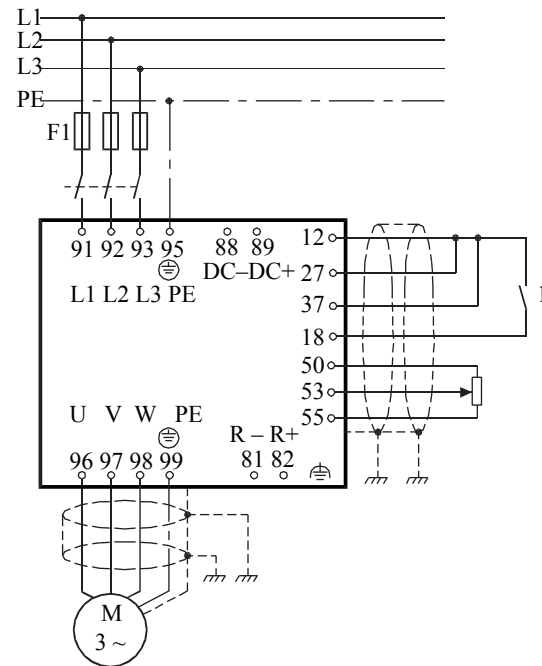

Figure 22: Diagram showing basic installation including line power, motor, start/stop key, and potentiometer for speed adjustment

4.1.5 Cooling

- To provide cooling airflow, mount the unit to a solid flat surface or to the optional back plate.
- Top and bottom clearance for air cooling must be provided. Generally 225 mm (9 in) is required.
- Improper mounting can result in over heating and reduced performance.
- Derating for temperatures starting between 45°C (113°F) and 50° C (122°F) and elevation 1,000 m (3,300 ft) above sea level must be considered.

4.1.6 Lifting

Always lift the adjustable frequency drive using the dedicated lifting holes. For all D and E2 (IP00) enclosures, use a bar to avoid bending the lifting holes of the adjustable frequency drive.

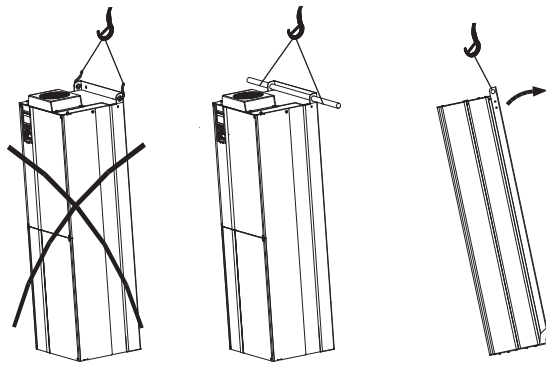

Figure 23: Recommended lifting method, frame sizes D and E

NOTICE:

The lifting bar must be able to handle the weight of the adjustable frequency drive. See Mechanical Dimensions for the weight of the different frame sizes. maximum diameter for bar is 1 in (2.5 cm). The angle from the top of the drive to the lifting cable should be 60°C or greater.

4.1.7 Terminal and connection

Take the following terminal positions into consideration when you design for cable access.

Be aware that the power cables are heavy and hard to bend. Give thought to the optimum position of the adjustable frequency drive for ensuring easy installation of the cables.

Terminal locations – D enclosures

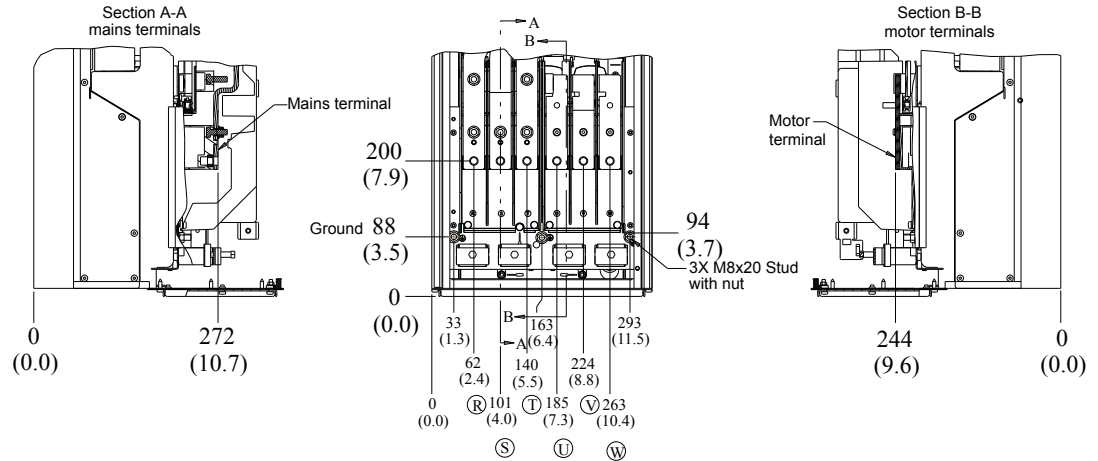

Figure 24: Terminal locations – D1h

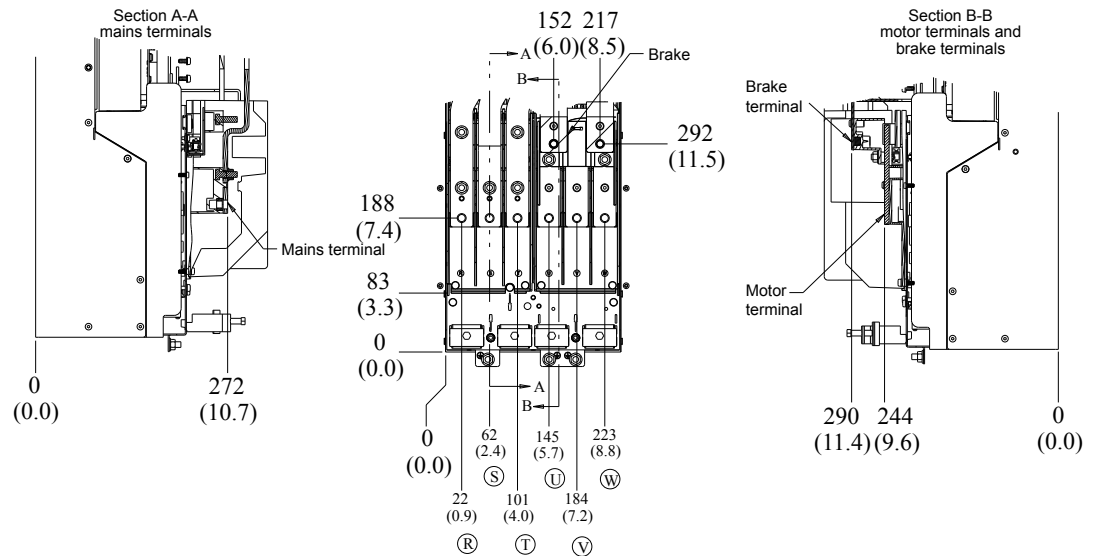

Figure 25: Terminal locations – D3h

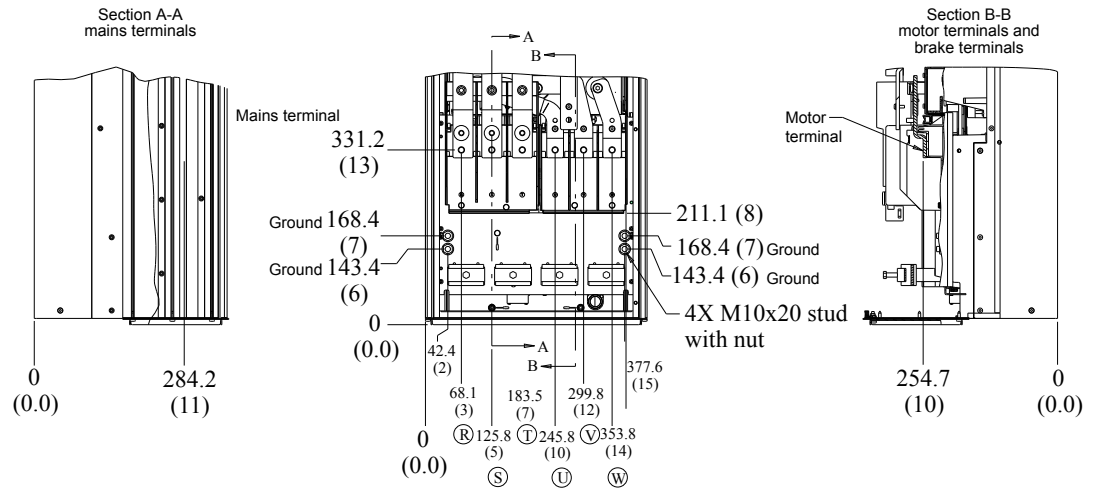

Figure 26: Terminal locations – D2h

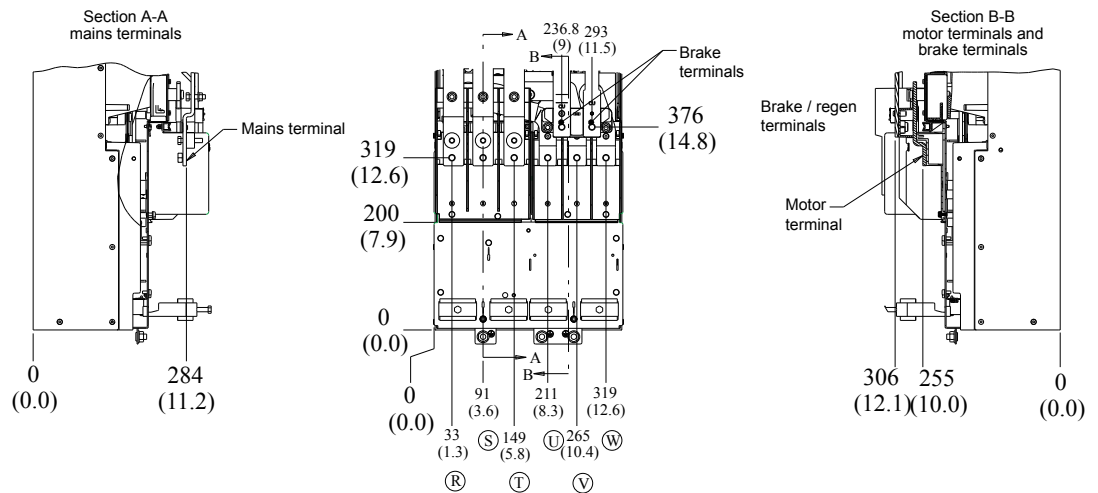

Figure 27: Terminal locations – D4h

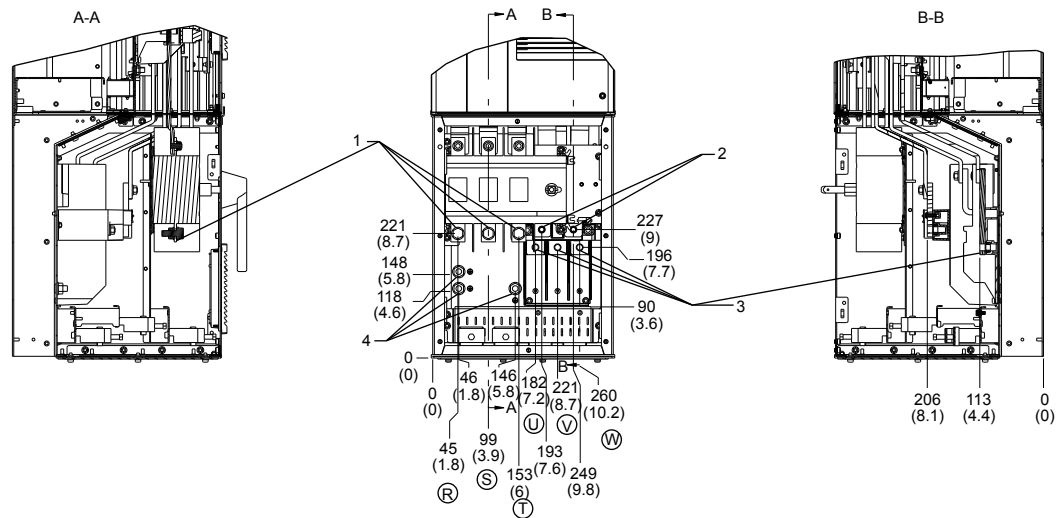

Figure 28: Terminal locations – D5h with disconnect option

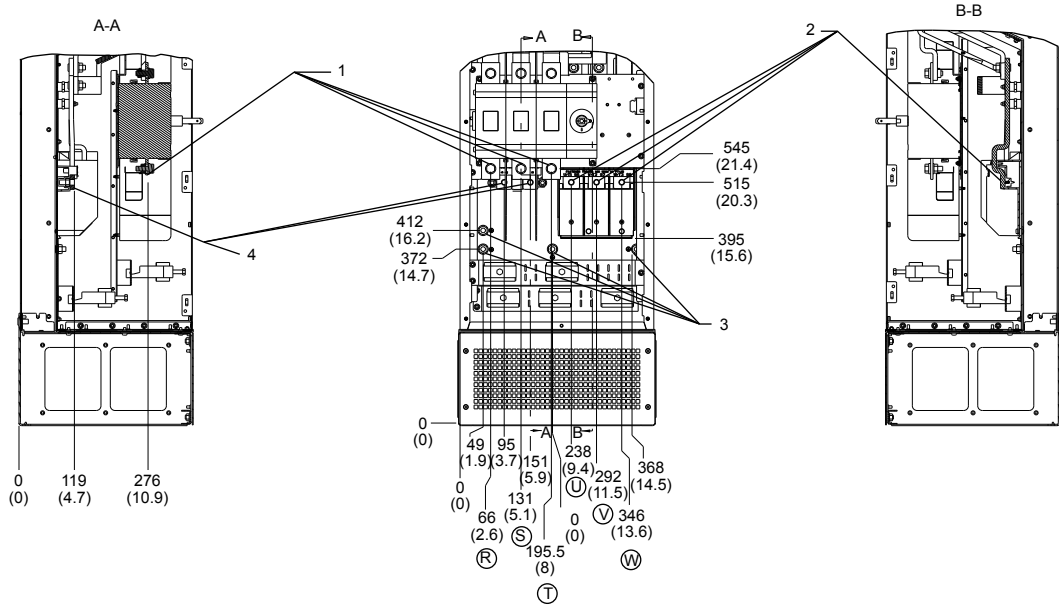

Figure 29: Terminal locations – D7h with disconnect option

1. Mains terminals
2. Brake terminals
3. Motor terminals
4. Earth/Ground terminals

Terminal locations – E enclosures

Consider the following terminal positions when designing the cable access.

Terminal locations – E1

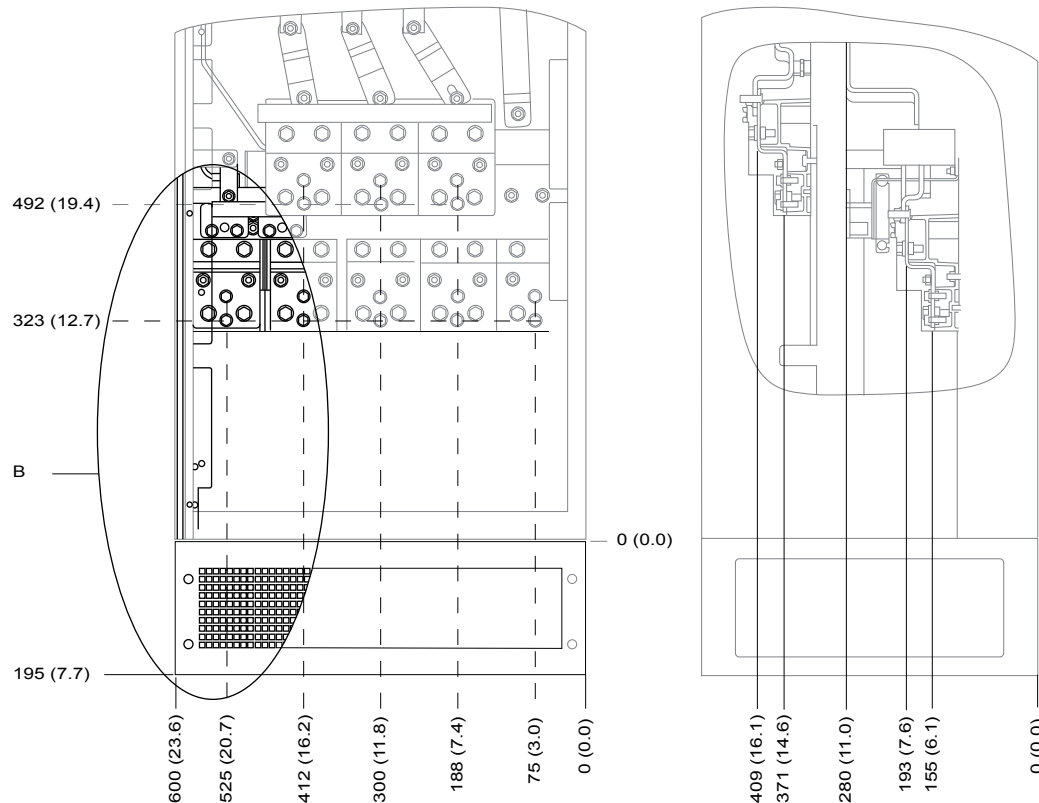

Figure 30: IP21 (NEMA Type 1) and IP54 (NEMA Type 12) Enclosure Power Connection Positions

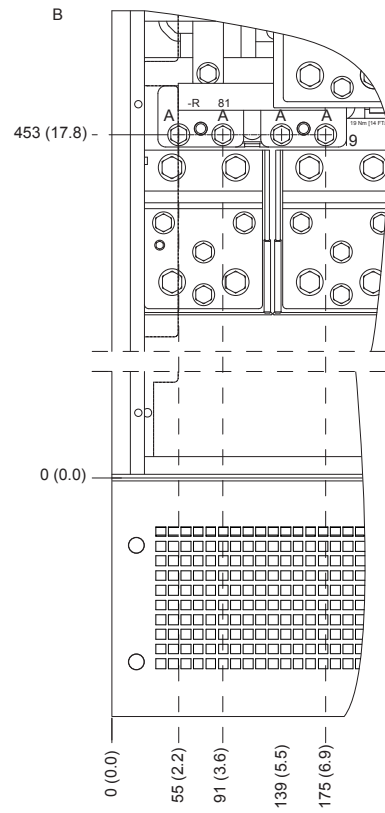

Figure 31: IP21 (NEMA Type 1) and IP54 (NEMA Type 12) Enclosure Power Connection Position (Detail B)

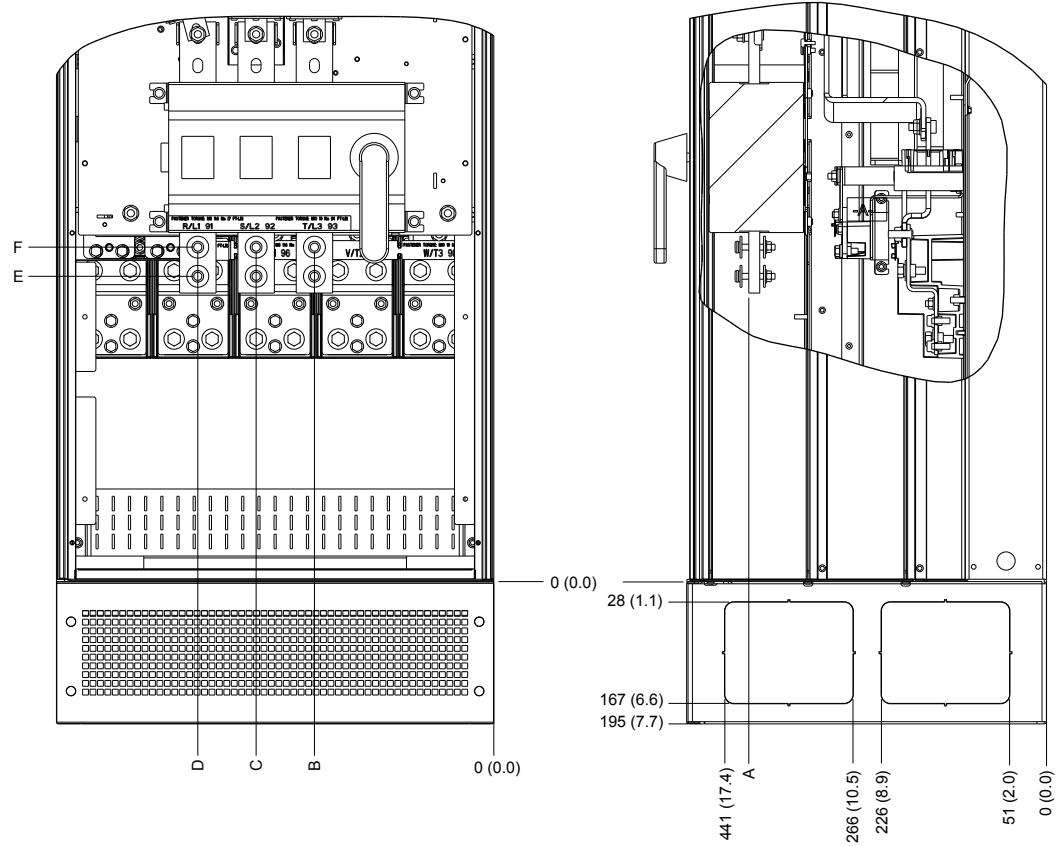

Figure 32: IP21 (NEMA Type 1) and IP54 (NEMA Type 12) Enclosure Power Connection Position of Disconnect Switch

Table 4: Dimensions for disconnect terminal

Enclosure size	Unit type	Dimensions (mm)/(in)					
E1	IP54/IP21 UL and NEMA 1/ NEMA12						
	450-600 HP (575 V)	396 (15.6)	267 (10.5)	332 (13.1)	397 (15.6)	528 (20.8)	N/A
	500-600 HP (400 V)	408 (16.1)	246 (9.7)	326 (12.8)	406 (16.0)	419 (16.5)	459 (18.1)

Terminal locations – E2

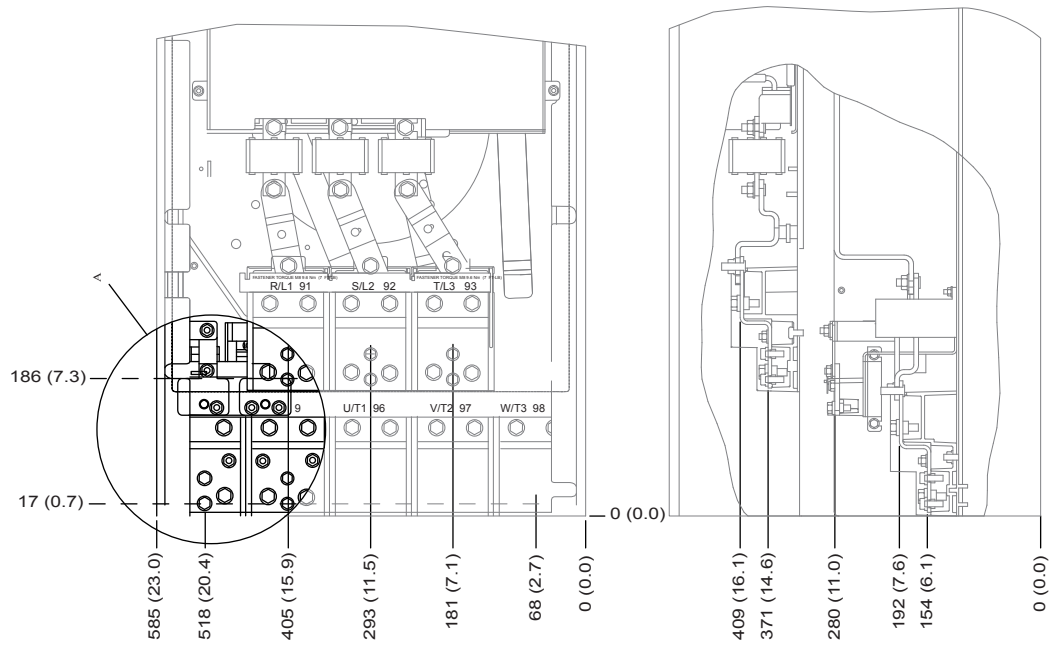

Figure 33: IP00 Enclosure Power Connection Positions

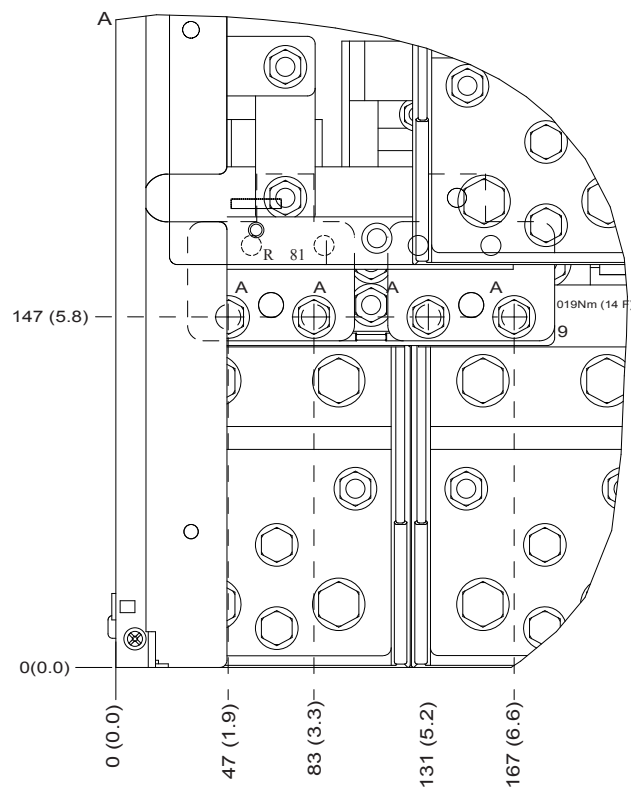

Figure 34: IP00 Enclosure Power Connection Positions

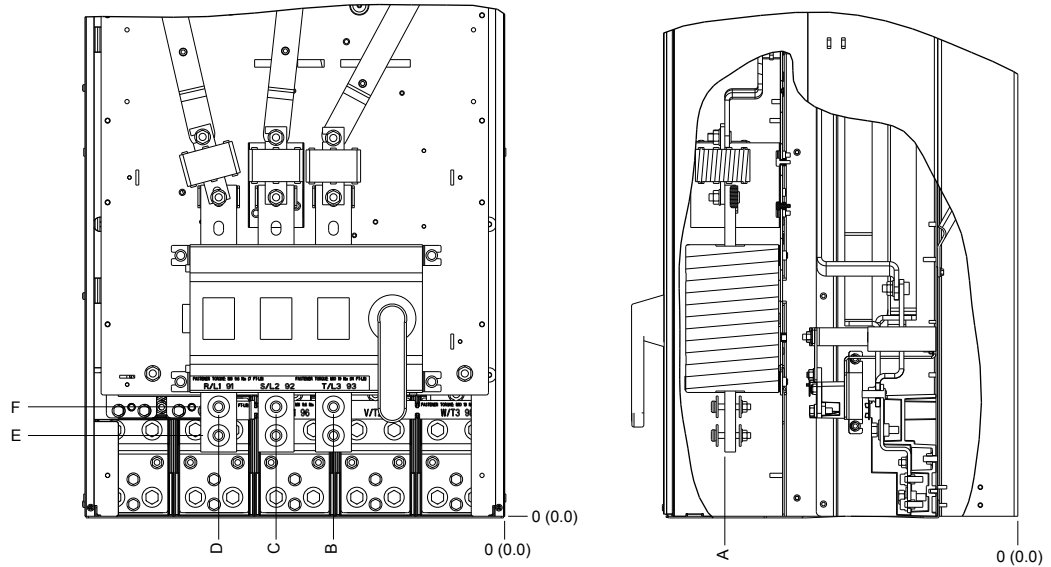

Figure 35: IP00 Enclosure Power Connections Positions of Disconnect Switch

The power cables are heavy and difficult to bend. Consider the optimum position of the frequency converter for ensuring easy installation of the cables.

Each terminal allows use of up to 4 cables with cable lugs or use of standard box lug. Ground is connected to relevant termination point in the frequency converter.

If lugs are wider than 39 mm, install supplied barriers on the mains input side of the disconnect.

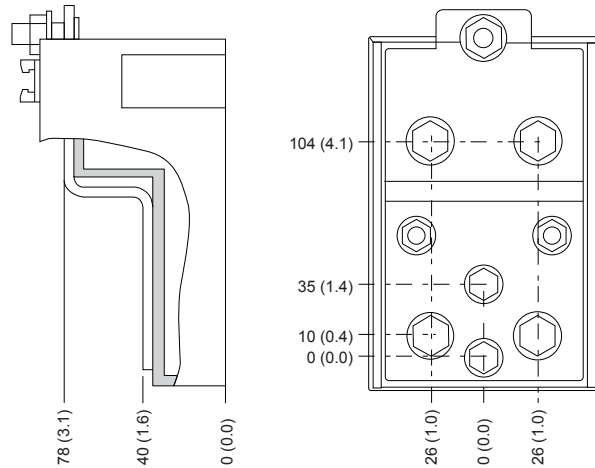

Figure 36: Terminal in Detail

Power connections can be made to positions A or B.

Table 5: Dimensions for Disconnect Terminal

Enclosure size	Unit type	Dimensions (mm)/(in)					
		A	B	C	D	E	F
E2	IP00/Chassis						
	450-600 HP (575 V)	396 (15.6)	268 (10.6)	333 (13.1)	398 (15.7)	221 (8.7)	N/A
	500-600 HP (400 V)	408 (16.1)	239 (9.4)	319 (12.5)	399 (15.7)	113 (4.4)	153 (6.0)

4.1.8 Gland/Conduit entry IP21 (NEMA 1) and IP54 (NEMA12)

Cables are connected through the gland plate from the bottom. Remove the plate and plan where to place the entry for the glands or conduits.

Prepare holes in the marked area in Illustration 3.35 to 3.39.

NOTICE:

The gland plate must be fitted to the frequency converter to ensure the specified protection degree, as well as ensuring proper cooling of the unit. If the gland plate is not mounted, the frequency converter may trip on Alarm 69, Pwr. Card Temp

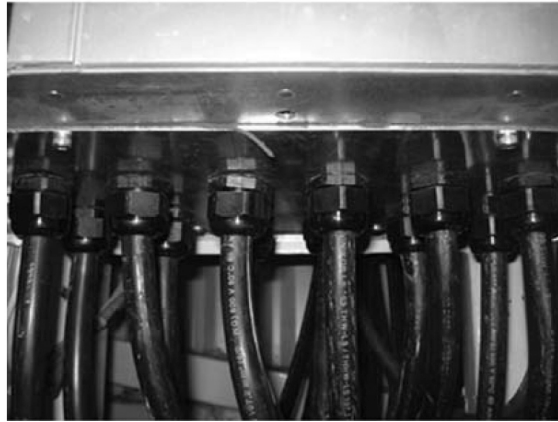

Figure 37: Example of proper installation of the connector plate

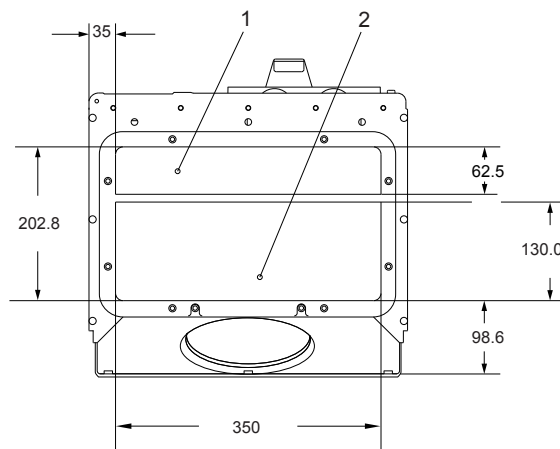

Figure 38: Enclosure size E1

Cable entries viewed from the bottom of the frequency converter – 1) Mains side 2) Motor side

4.1.9 NEMA-3R cover kit

The NEMA 3R cover kit is designed for D1h and D2h enclosure sizes for the following applications:

- This kit adds a cover to the outside vents of the frequency converter and provides NEMA 3R compliant protection against weather and hosed water. The kit is used only with frequency converters that have the enclosure Code C-N3R.

The NEMA 3R kit contains the following parts:

- Top plate (1)
- Gland plate with attached gasket (1)
- NEMA 3R cover (1)
- Adhesive label (1)
- 3-sectioned plastic bag containing:

- For top plate, lifting eyelets (2) and screws (6) without captive washers.
- For gland plate, screws (6) for D1h or (8) for D2h. The screws have captive washers.
- For NEMA 3R cover, screws (6) with captive washers.

4.1.10 Install the top plate

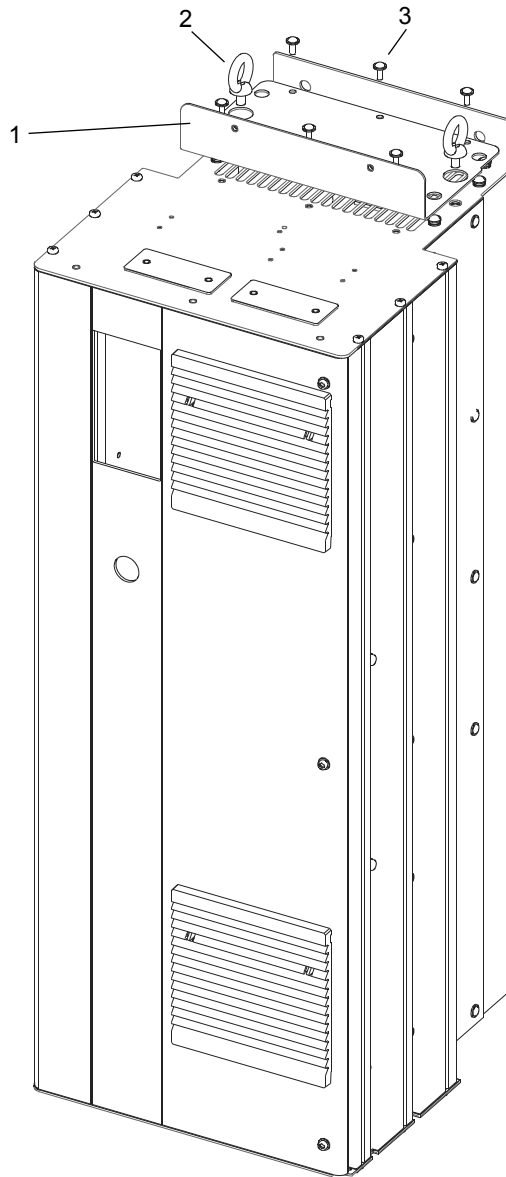

Figure 39: Installing NEMA 3R Top Plate

1. Top plate
 2. Eye bolt
 3. Screw without captive washer
1. Remove the four (4) screws along the back side of the top vent opening.
 2. Place the top plate over the top vent opening.
 3. Secure the top plate with the six (6) screws without captive washers provided in the bag. Torque to 2.3 Nm (20 in/lbs).
 4. If lifting eyebolts are needed for the application, remove the plated eyebolts that came with the unit and replace with the stainless steel eyebolts provided in the bag.

NOTICE:

UL NEMA 3R RATING

Eyebolts are not required to meet UL NEMA 3R rating.

4.1.11 Install the gland plate

1. Remove the existing gland plate and gasket from the bottom of the frequency converter by removing 6 screws (T25) from the D1h or 8 screws (T25) from the D2h.
2. Make sure that the flange on the frequency converter is smooth and clean in preparation for the new gasket.
3. Place the new gland plate over the opening, with the gasket side facing the opening.
4. Secure the new gland plate to the frequency converter using the provided screws with captive washers (6) for D1h or (8) for the D2h. Torque to 2.3 Nm (20 in/lbs).

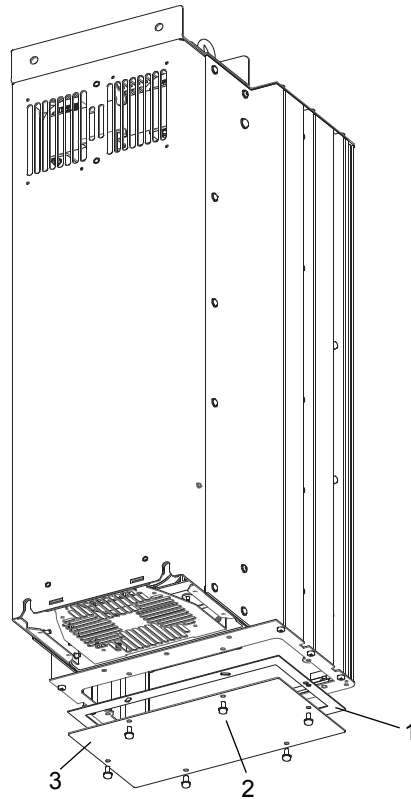

Figure 40: Removing Gland Plate

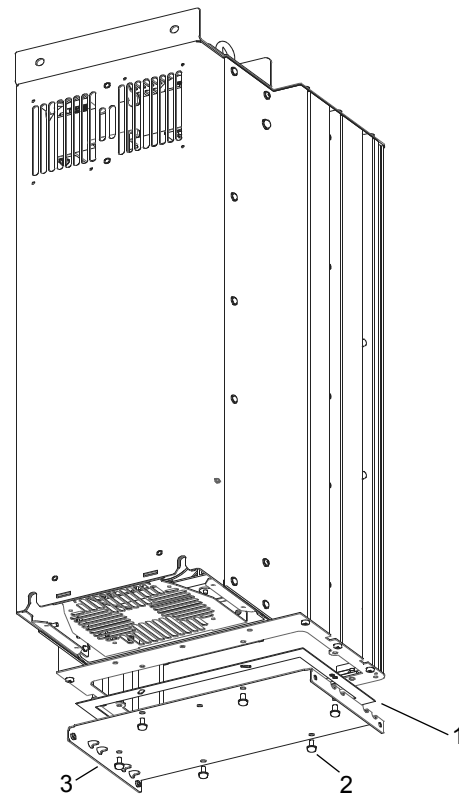

Figure 41: Installing NEMA 3R Gland Plate

1. Gasket
2. Screw with captive washer
3. Gland plate

4.1.12 Install the NEMA 3R cover

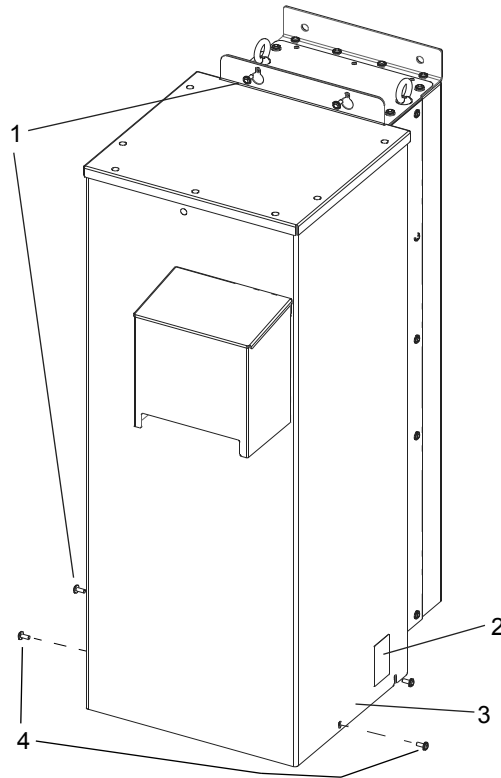

Figure 42: Installing NEMA 3R Cover

1. Screw without captive washer
2. NEMA 3R sticker
3. NEMA 3R cover
4. Screws to remove for taking off the NEMA 3R cover

1. Set the NEMA 3R cover over the top of the frequency converter. Align the NEMA 3R cover with the screw holes on the top mounting plate and the screw holes on the side of the unit.
2. Using the 6 screws provided in the bag, loosely secure the cover to the frequency converter.
3. Torque all 6 screws to 2.3 Nm (20 in/lbs).
4. Apply adhesive label to the cover.

To remove the NEMA 3R cover after it has been installed, remove the front 2 screws on the bottom of the unit. The cover can be removed after the other 4 screws are loosened since the cover has slotted screw openings.

Calculating Nominal Current when Using a NEMA 3R Cover

The nominal current of a frequency converter with the NEMA 3R cover is 88% of its current rating. For example, in a AVB45000 standard IP21 frequency converter, the nominal output current in nominal overload mode is 590 A. With the NEMA 3R cover, the normal overload current is $0.88 \times 590 = 519.2$ A. The same calculation is used to calculate the nominal current for the high overload mode.

Derating For Ambient Temperature When Using A NEMA 3R Cover

Using the NEMA 3R cover kit requires derating due to higher ambient temperatures within the enclosure. Using SFAVM (stator flux asynchronous vector modulation) gives greater switching control, but generates more heat than using 60°AVM (asynchronous vector modulation). SFAVM switches throughout the entire cycle, where 60° AVM only switches 2/3 of the time.

The maximum switching frequency is 16 kHz for 60° AVM and 10 kHz for SFAVM. The discrete switching frequencies are shown in the following figure.

Table 6: Switching patterns

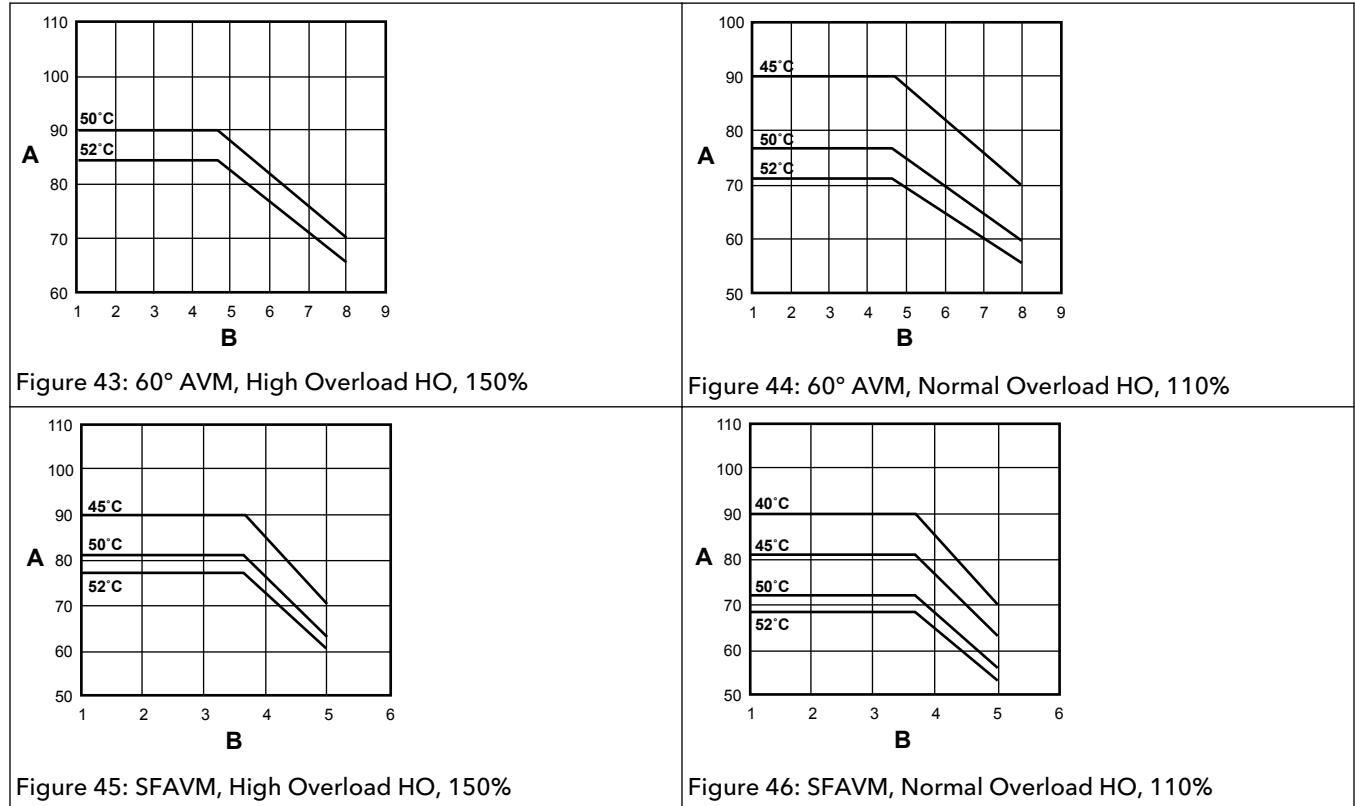

- A % of drive output, nominal HO current
- B F_{SW} (KHz)

5 Electrical Installation

5.1 Precautions



WARNING:

- **EQUIPMENT HAZARD.** Rotating shafts and electrical equipment can be hazardous. All electrical work must conform to national and local electrical codes. Installation, start-up, and maintenance must be performed by trained and qualified personnel. Failure to follow these guidelines could result in death or serious injury.
 - **FIRE HAZARD.** Consult the Brake Design Guide IM257 for details on proper installation of a brake resistor.
-

NOTICE:

WIRING ISOLATION. Run input power, motor wiring and control wiring in three separate metallic conduits or use separated shielded cable for high frequency noise isolation. Failure to isolate power, motor and control wiring could result in less than optimum frequency converter and associated equipment performance.

For your safety comply with the following requirements:

- Electronic control equipment is connected to hazardous mains voltage. Extreme care should be taken to protect against electrical hazards when applying power to the unit.
- Run motor cable from multiple frequency converters separately. Induced voltage can charge equipment capacitors even with the equipment turned off and locked.
- Field wiring terminals are not intended to receive a conductor one size larger.

Overload and equipment protection:

- An electronically activated function within the frequency converter provides overload protection in the motor. The overload calculates the level of increase to activate timing for the trip (controller output stop) function. The higher the current draw, the quicker the trip response. The overload provides Class 20 motor protection. See Warnings and alarms section for details on the trip function.
- All frequency converters must be provided with short-circuit and over-current protection. Input fusing is required to provide this protection. If not factory supplied, fuses must be provided by the installer as part of installations. See Fuse specifications section for details.

Wire type and ratings:

- All wiring must comply with local and national regulations regarding cross section and ambient temperature requirements.
- It is recommended the all power connections be made with a minimum 75°C rated copper wire.
- See Power-dependent specifications for recommended wire sizes.

Earth (grounding) requirements



WARNING:

For operator safety, it is important to ground the frequency converter properly in accordance with national and local electrical codes as well as instructions contained within this document. Ground currents are higher than 3.5 mA. Failure to ground the frequency converter properly could result in death or serious injury.

NOTICE:

It is the responsibility of the user or certified electrical installer to ensure correct grounding (earthing) of the equipment in accordance with national and local electrical codes and standards.

- Follow all local and national electrical codes to ground electrical equipment properly.
- Proper protective grounding for equipment with ground currents higher than 3.5 mA must be established. See the Leakage current (>3.5 mA) section for details.
- A dedicated ground wire is required for input power, motor power and control wiring.
- Use the clamps provided with the equipment for proper ground connections.
- Do not ground one frequency converter to another in a “daisy chain” fashion.
- Keep the ground wire connections as short as possible.
- Using high-strand wire to reduce electrical noise is recommended.
- Follow motor manufacturer wiring requirements.

Leakage current (>3.5 mA)

Follow national and local codes regarding protective earthing of equipment with a leakage current > 3.5 mA. Frequency converter technology implies high frequency switching at high power. This will generate a leakage current in the earth connection. A fault current in the frequency converter at the output power terminals might contain a DC component which can charge the filter capacitors and cause a transient earth current. The earth leakage current depends on various system configurations including RFI filtering, screened motor cables, and frequency converter power.

EN/EC61800-5-1 (Power Drive System Product standard) requires special care if the leakage current exceeds 3.5 mA. Earth grounding must be reinforced in one of the following ways:

- Earth ground wire of at least 8 AWG or 10 mm².
- Two separate earth ground wires both complying with the dimensioning rules.

See EN60364-5-54 section 543.7 for further information.

Using GFCIs (RCDs)

Where Ground Fault Circuit Interrupters (GFCIs) and residual current devices (RCDs), also known as earth leakage circuit breakers (ELCBs), are used, comply with the following:

- Use GFCIs (RCDs) of type B only which are capable of detecting AC and DC currents.
- Use GFCIs (RCDs) with an inrush delay to prevent faults due to transient earth currents.
- Dimension GFCIs (RCDs) according to the system configuration and environmental considerations.

5.2 Basic electrical connection

This section contains detailed instructions for wiring the frequency converter. The following tasks are described:

- Wiring the motor to the frequency converter output terminals
- Wiring the AC mains to the frequency converter input terminals
- Connecting control and serial communication wiring
- After power has been applied, checking input and motor power; programming control terminals for their intended functions

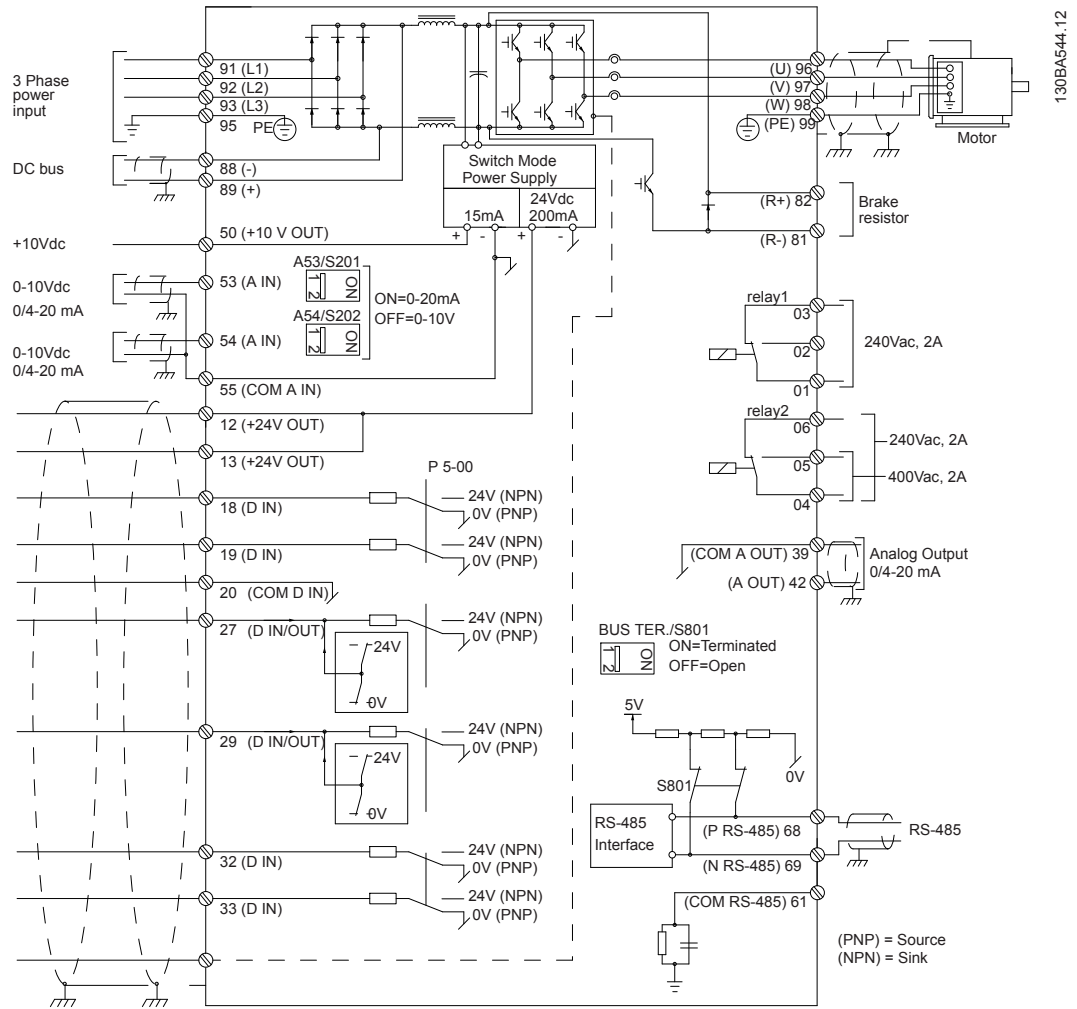

Figure 47: Basic electrical connection

Terminal 37 is the input to be used for Safe Stop. For instructions on safe stop installation, refer to the section Safe Stop Installation in the adjustable frequency drive Design Guide. See also section Safe Stop and Safe Stop Installation.

In rare cases, very long cables and analog signals may, depending on installation, result in 50/60 Hz ground loops due to noise from power line supply cables.

If this occurs, it may be necessary to break the shield or insert a 100 nF capacitor between shield and chassis.

Digital and analog inputs and outputs

The digital and analog inputs and outputs must be connected to the adjustable frequency drive common inputs (terminal 20, 55, 39) to avoid ground currents from both groups to affect other groups. For example, switching on the digital input may disturb the analog input signal.

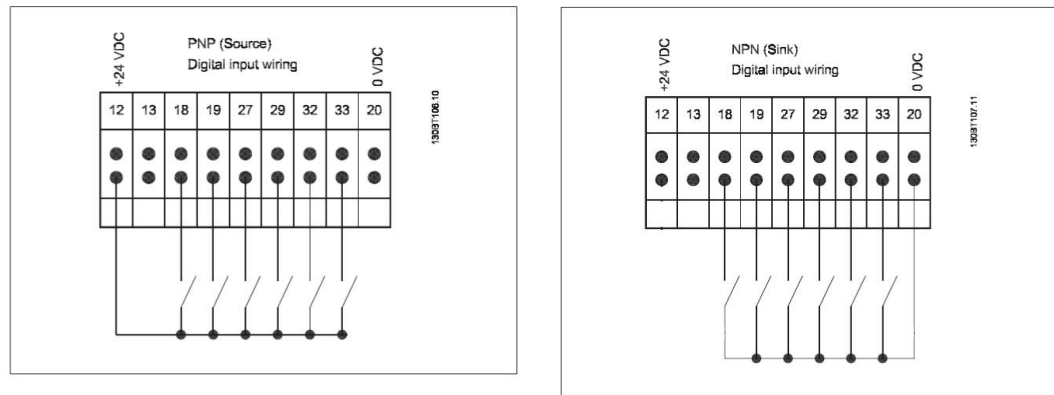

Figure 48: Input polarity of control terminals

Note: To comply with EMC emission specifications, shielded/armored cables are recommended. If an unshielded/unarmored cable is used, see section Power and Control Wiring for Unshielded Cables. For more information, see EMC Test Results in the Design Guide.

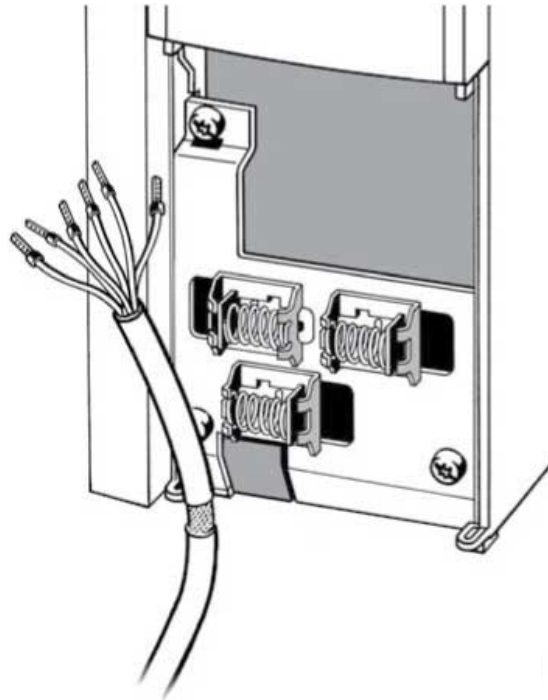

Figure 49: Control cable

Connect the wires as described in the Instruction Manual for the adjustable frequency drive. Remember to connect the shields in a proper way to ensure optimum electrical immunity.

5.3 Power connections

Cabling and fusing

NOTICE:

All cabling must comply with national and local regulations on cable cross-sections and ambient temperature. UL applications require 167°F (75°C) copper conductors are thermally acceptable for the adjustable frequency drive to use in non-UL applications.

The power cable connections are situated as shown below. Dimensioning of cable cross-section must be done in accordance with the current rating and local regulations. See the specifications section for details.

For protection of the adjustable frequency drive, the recommended fuses must be used or the unit must be with built-in fuses. Recommended fuses can be seen in the tables of the fuse section. Always ensure that proper fusing is done according to local regulations.

The AC line input connections are fitted to the line power switch if this is included.

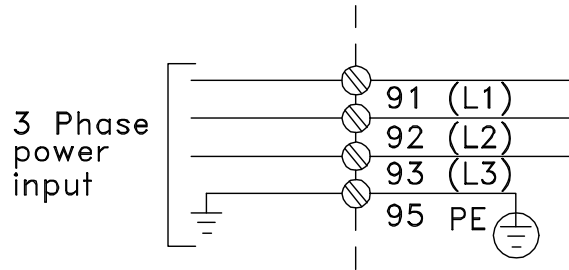

Figure 50: AC line input connections

NOTICE:

To comply with EMC emission specifications, shielded/armored cables are recommended. If an unshielded/unarmored cable is used, see section Power and Control Wiring for Unshielded Cables. For more information, see EMC Test Results in the Design Guide.

See section General Specifications for correct dimensioning of motor cable cross-section and length.

Shielding of cables

Avoid installation with twisted shield ends (pigtailed). They spoil the shielding effect at higher frequencies. If it is necessary to break the shield to install a motor isolator or motor contactor, the shield must be continued at the lowest possible HF impedance.

Connect the motor cable shield to both the de-coupling plate of the adjustable frequency drive and to the metal housing of the motor.

Make the shield connections with the largest possible surface area (cable clamp). This is done by using the supplied installation devices within the adjustable frequency drive.

Cable-length and cross-section

The adjustable frequency drive has been EMC tested with a given length of cable. Keep the motor cable as short as possible to reduce the noise level and leakage currents.

Switching frequency

When adjustable frequency drives are used together with sine-wave filters to reduce the acoustic noise from a motor, the switching frequency must be set according to the instructions in par. 14-01 Switching Frequency.

Terminal number	96	97	98	99	Description
	U	V	W	PE ¹⁾	Motor voltage 0-100% of AC line voltage. 3 wires out of motor
	U1 W2	V1 U2	W1 V2	PE ¹⁾	Delta-connected 6 wires
	U1	V1	W1	PE ¹⁾	Star-connected U2, V2, W2 U2, V2 and W2 to be interconnected separately

¹⁾ Protected ground connection

Note: In motors without phase insulation paper or other insulation reinforcement suitable for operation with voltage supply (such as an adjustable frequency drive), fit a sine-wave filter on the output of the adjustable frequency drive.

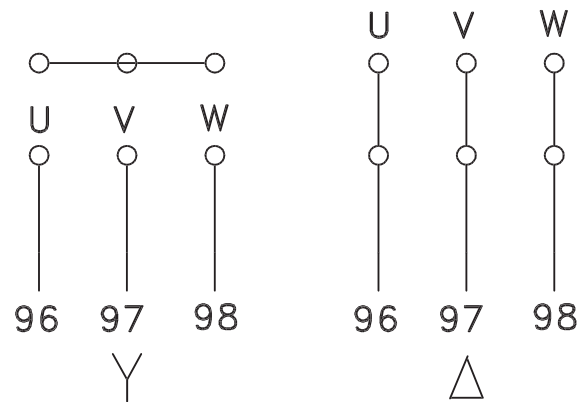

Figure 51: Motor connections

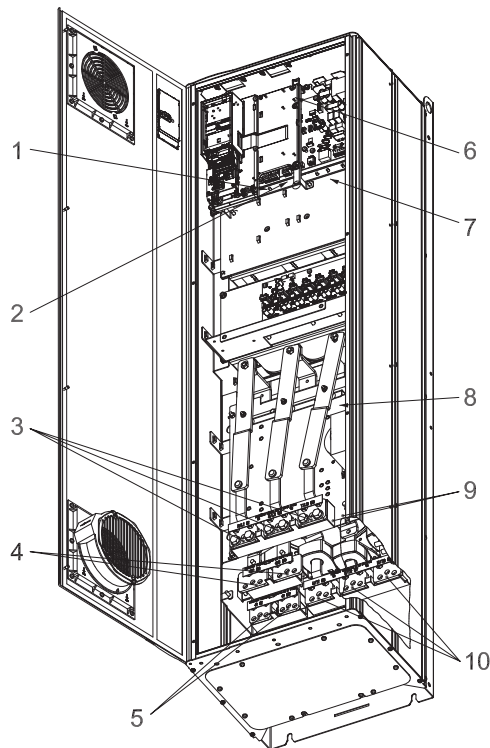

Figure 52: Compact IP 21 (NEMA 1) and IP 54 (NEMA 12), frame size D1

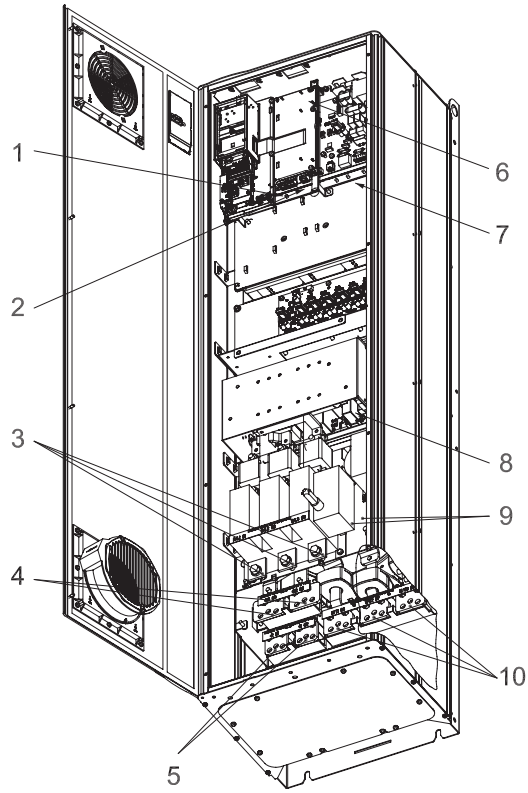

Figure 53: Compact IP 21 (NEMA 1) and IP 54 (NEMA 12) with disconnect, fuse and RFI filter, frame size D2

1. AUX Relay
2. Temperature switch
3. Line
4. Load sharing
5. Brake
6. SMPS Fuse (see fuse tables for part number)
7. AUX Fan
8. Fan fuse (see fuse tables for part number)
9. Line power ground
10. Motor

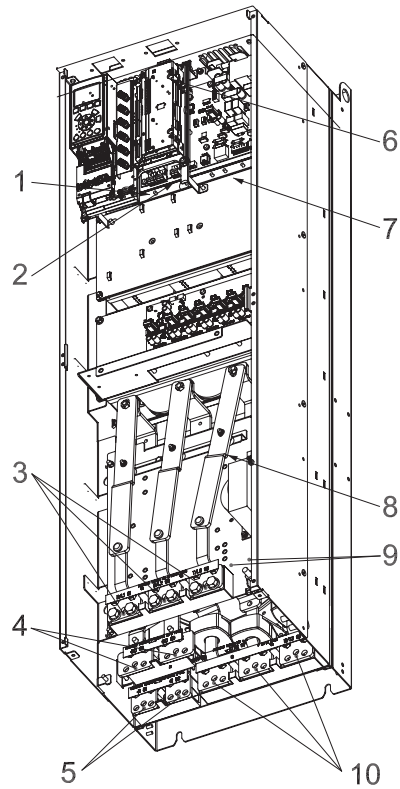

Figure 54: Compact IP 00 (chassis), frame size D3

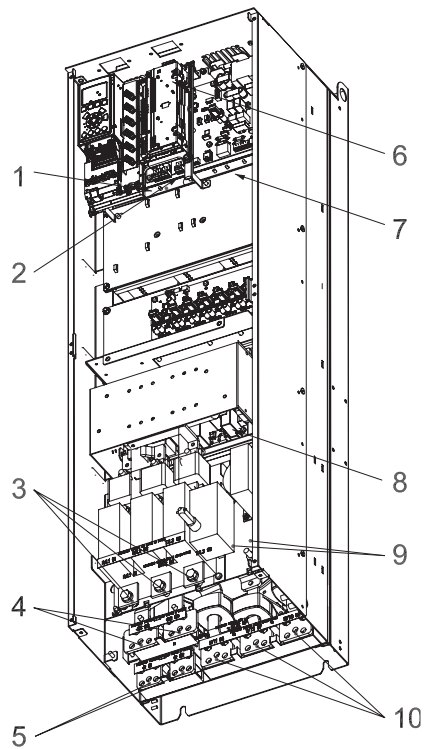

Figure 55: Compact IP 00 (chassis) with disconnect, fuse and RFI filter, frame size D4

1. AUX Relay
2. Temperature switch
3. Line
4. Load sharing

5. Brake
6. SMPS Fuse (see fuse tables for part number)
7. AUX Fan
8. Fan fuse (see fuse tables for part number)
9. Line power ground
10. Motor

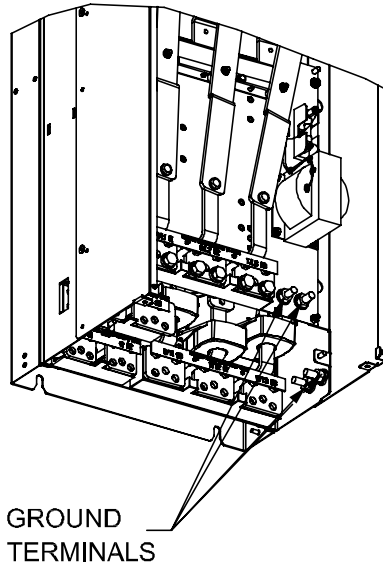

Figure 56: Position of ground terminals IP00, frame sizes D

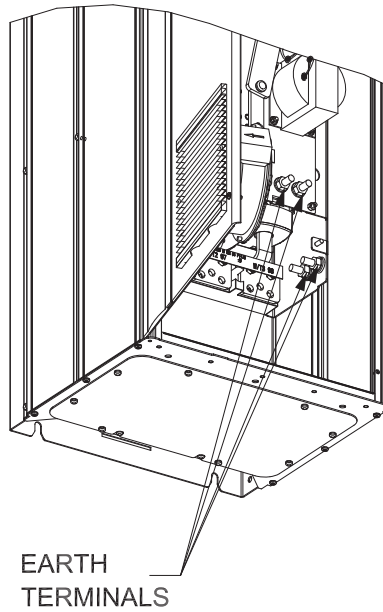

Figure 57: Position of ground terminals IP21 (NEMA type 1) and IP54 (NEMA type 12)
D2 and D4 shown as examples. D1 and D3 are equivalent.

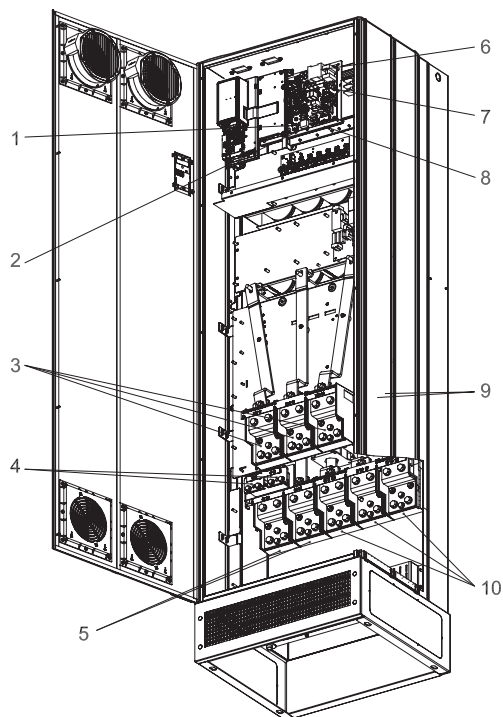

Figure 58: Compact IP 21 (NEMA 1) and IP 54 (NEMA 12) frame size E1

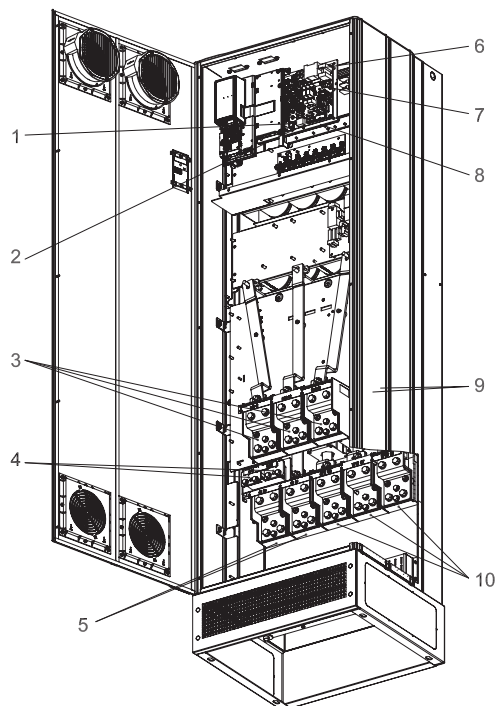

Figure 59: Compact IP 00 (chassis) with disconnect, fuse and RFI filter, frame size E2

1. AUX Relay
2. Temperature switch
3. Line
4. Load sharing
5. Brake
6. SMPS Fuse (see fuse tables for part number)

7. AUX Fan
8. Fan fuse (see fuse tables for part number)
9. Line power ground
10. Motor

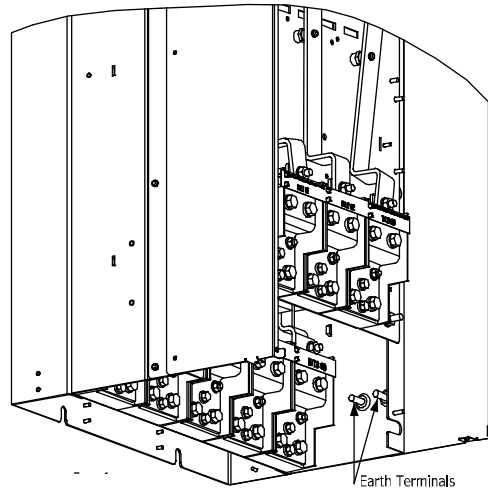

Figure 60: Position of ground terminals IP00, frame sizes E

5.4 Power and control wiring for unshielded cables



Electrical Hazard:

Induced Voltage

- Run motor cables from multiple drives separately. Induced voltage from output motor cables run together can charge equipment capacitors even with the equipment turned off and locked out. Failure to run output cables separately could result in death or serious injury.

NOTICE:

Run drive input power, motor wiring, and control wiring in three separate metallic conduits or raceways for high frequency noise isolation. Failure to isolate power, motor, and control wiring could result in less than optimum controller and associated equipment performance.

Because the power wiring carries high frequency electrical pulses, it is important that input power and motor power are run in separate conduit. If the incoming power wiring is run in the same conduit as the motor wiring, these pulses can couple electrical noise back onto the building power grid. Control wiring should always be isolated from the high voltage power wiring.

When shielded/armored cable is not used, at least three separate conduits must be connected to the panel option (see figure below).

- Power wiring into the enclosure
- Power wiring from the enclosure to the motor
- Control wiring

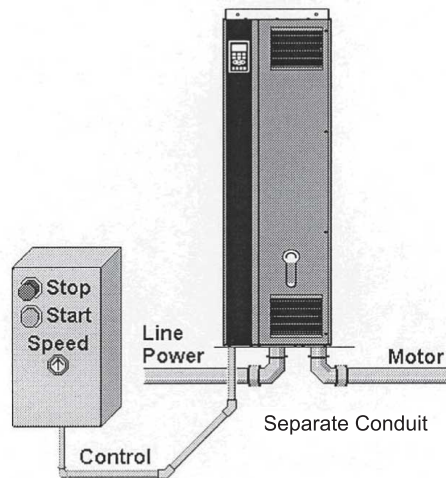

Figure 61: Power and control wiring connection

5.5 Grounding

The following basic issues need to be considered when installing an adjustable frequency drive, so as to obtain electromagnetic compatibility (EMC).

- Safety, grounding: Please note that the adjustable frequency drive has a high leakage current and must be grounded appropriately for safety reasons. Always follow local safety regulations.
- High-frequency grounding: Keep the ground wire connections as short as possible.

Connect the different ground systems at the lowest possible conductor impedance. The lowest possible conductor impedance is obtained by keeping the conductor as short as possible and by using the greatest possible surface area.

The metal cabinets of the different devices are mounted on the cabinet rear plate using the lowest possible HF impedance. This prevents having different HF voltages for the individual devices and prevents the risk of radio interference currents running in connection cables that may be used between the devices, as radio interference is reduced.

In order to obtain a low HF impedance, use the fastening bolts of the devices as HF connections to the rear plate. It is necessary to remove insulating paint and the like from the fastening points.

5.6 Extra protection (RCD)

ELCB relays, multiple protective grounding or grounding can be used as extra protection, provided that local safety regulations are complied with.

In the case of a ground fault, a DC component may develop in the fault current.

If ELCB relays are used, local regulations must be observed. Relays must be suitable for protection of 3-phase equipment with a bridge rectifier and for a brief discharge on power-up.

See also the section Special COnditions in the Design Guide.

5.7 Torque

When tightening all electrical connections, it is very important to tighten with the correct torque. Too low or too high torque results in a bad electrical connection. Use a torque wrench to ensure correct torque.

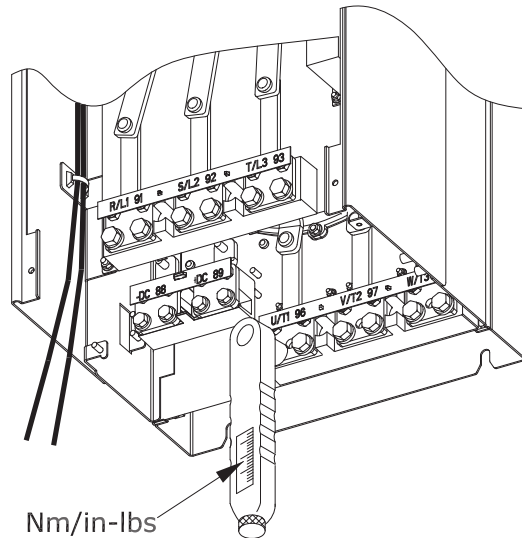

Figure 62: Torque wrench

Frame size	Terminal	Torque	Bolt size
D1, D2, D3 and D4	Line power motor	19 Nm (168 in-lbs)	M10
	Load sharing Brake	9.5 Nm (84 in-lbs)	M8
E1 and E2	Line power motor	19 Nm (168 in-lbs)	M10
	Load sharing Brake	9.5 Nm (84 in-lbs)	M8

5.8 Shielded cables

It is important that shielded and armored cables are connected properly to ensure high EMC immunity and low emissions.

Connection can be made by either cable connectors or clamps:

- EMC cable connectors: Generally available cable connectors can be used to ensure an optimum EMC connection.
- EMC cable clamp: Clamps allowing for easy connection are supplied with the adjustable frequency drive.

5.9 Motor connection



WARNING:

INDUCED VOLTAGE. Run output motor cables from multiple frequency converters separately. Induced voltage from output motor cables run together can charge equipment capacitors even with the equipment turned off and locked out. Failure to run output motor cables separately could result in death or serious injury.

Be sure the following are adhered to:

- For maximum wire sizes see Power-dependent Specifications.
- Comply with local and national electrical codes
- Connector plates are provided at the base of IP21/54 and higher (NEMA 1/12) units.
- Do not install power factor correction capacitors between the frequency converter and the motor
- Do not wire a starting or pole-changing device between the frequency converter and the motor
- Connect the 3-phase motor wiring to terminals 96 (U), 97 (V), and 98 (W)
- Ground the cable in accordance with grounding instructions provided

- Torque terminals in accordance with the informations provided in Connection tightening torques.
- Follow motor manufacturer wiring requirements

The motor must be connected to terminals U/T1/96, V/T2/97, W/T3/98. Ground to terminal 99. All types of three-phase asynchronous standard motors can be used with an adjustable frequency drive unit. The factory setting is for clockwise rotation with the adjustable frequency drive output connected as follows:

Terminal number	Function
96, 97, 98, 99	Line power U/T1, V/T2, W/T3 Ground

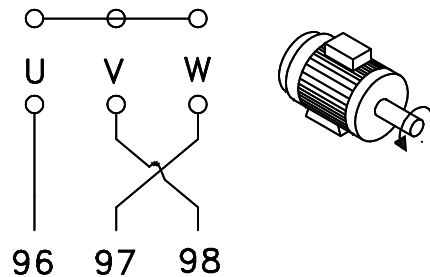
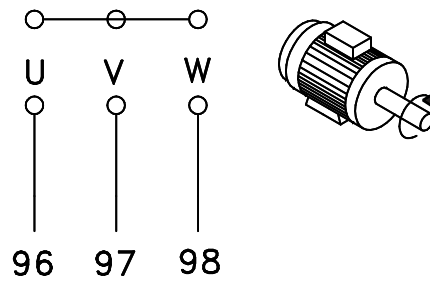

Figure 63: Motor connections

- Terminal U/T1/96 connected to U-phase
- Terminal V/T2/97 connected to V-phase
- Terminal W/T3/98 connected to W-phase

The direction of rotation can be changed by switching two phases in the motor cable or by changing the setting of par. 4-10 Motor Speed Direction. Motor rotation check can be performed by using par. 1-28 Motor Rotation Check and following the steps shown in the display.

Output junction box requirements

The length, minimum 8 ft (2.5 m), and quantity of cables must be equal from each inverter module to the common terminal in the junction box.

- **NOTE:** If the retrofit application requires unequal amounts of wires per phase, consult the factory for requirements and documentation or use the top/bottom entry side cabinet option.

5.10 Shielding against electrical noise

Before mounting the line power cable, mount the EMC metal cover to ensure best EMC performance.

- **NOTE:** The EMC metal cover is only included in units with a H2-RFI Class A2 filter for all D and E frame units.

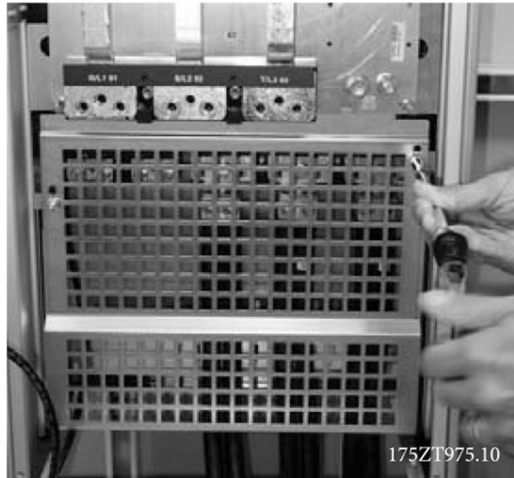

Figure 64: EMC shield

5.11 AC line input connections

The line power supply must be connected to terminals 91, 92 and 93. Ground is connected to the terminal to the right of terminal 93.

Terminal number	Function
91, 92, 93	Line power R/L1, S/L2, T/L3
94	Ground

NOTICE:

Check the nameplate to ensure that the AC line voltage of the adjustable frequency drive matches the power supply of your plant. Ensure that the power supply can supply the necessary current to the adjustable frequency drive. If the unit is without built-in fuses, ensure that the appropriate fuses have the correct current rating.

- All frequency converters may be used with an isolated input source as well as with ground reference power lines. When supplied from an isolated mains source (IT mains or floating delta) or TT/TN-S mains with a grounded leg (grounded delta), set 14-50 RFI Filter to (0) Off. When off, the internal RFI filter capacitors between the chassis and the intermediate circuit are isolated. Isolating the capacitors prevents damage to the intermediate circuit and reduces ground capacity currents in accordance with IEC 61800-3.
- Size wiring is based upon the input current of the frequency converter.
- Comply with local and national electrical codes for cable sizes.

- Ground the cable in accordance with the instructions provided.
- Connect 3-phase AC input power wiring to terminals L1, L2, L3.

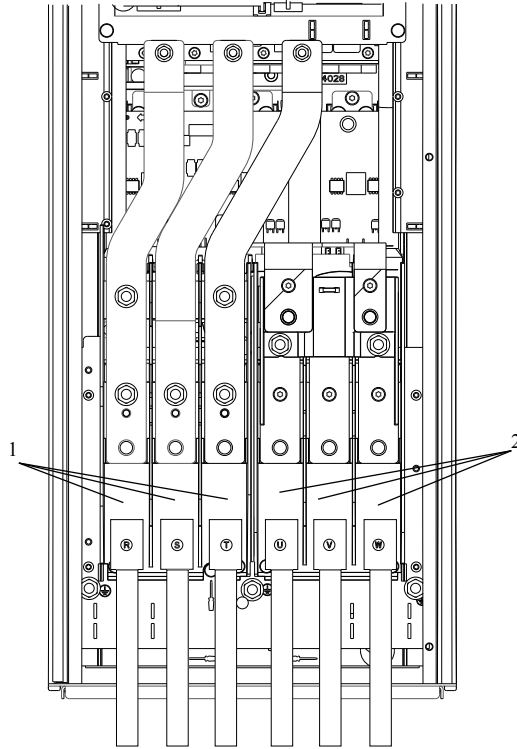

Figure 65: Connecting to AC Mains

1. Mains connection
2. Motor connection

5.12 External fan supply

Frame size D-E

If the adjustable frequency drive is supplied by DC or if the fan must run independently of the power supply, an external power supply can be applied.

The connection is made on the power card.

Terminal number	Function
100, 101	Auxiliary supply S, T
102, 103	Internal supply S, T

The connector located on the power card provides the AC line voltage connection for the cooling fans. The fans are factory-equipped to be supplied from a common AC line (jumpers between 100-102 and 101-103). If an external supply is needed, the jumpers are removed and the supply is connected to terminals 100 and 101. A 5 amp fuse should be used for protection. In UL applications, this should be a LittleFuse KLK-5 or equivalent.

5.13 Fuses and line power disconnectors

Branch circuit protection

In order to protect the installation against electrical and fire hazard, all branch circuits in an installation, switch gear, machines, etc., must be short-circuited and overcurrent protected according to national/international regulations.

Short-circuit protection

The adjustable frequency drive must be protected against short-circuit to avoid electrical and fire hazard. We recommend using the fuses mentioned below to protect service personnel and equipment in case of an internal failure in the drive. The adjustable frequency drive provides full short-circuit protection in case of a short-circuit on the motor output.

Overcurrent protection

Provide overload protection to avoid fire hazard due to overheating of the cables in the installation. The adjustable frequency drive is equipped with internal overcurrent protection that can be used for upstream overload protection (UL applications excluded). See par. 4-18 Current Limit. Moreover, fuses or circuit breakers can be used to provide the overcurrent protection in the installation. Overcurrent protection must always be carried out according to national regulations.

Fuse and Line Power Disconnectors tables are listed in Section 10 : Technical Specification.

5.14 Motor insulation and motor bearing currents

Motor insulation

For motor cable lengths \leq than the maximum cable length listed in the General Specifications tables, the following motor insulation ratings are recommended because the peak voltage can be up to twice the DC link voltage, 2.8 times the AC line voltage due to transmission line effects in the motor cable. If a motor has lower insulation rating, it is recommended to use a du/dt or sine-wave filter.

Nominal AC Line Voltage	Motor Insulation
$U_N \leq 420 \text{ V}$	Standard $U_{LL} = 1300 \text{ V}$
$420 \text{ V} < U_N \leq 500 \text{ V}$	Reinforced $U_{LL} = 1600 \text{ V}$
$500 \text{ V} < U_N \leq 600 \text{ V}$	Reinforced $U_{LL} = 1800 \text{ V}$
$600 \text{ V} < U_N \leq 690 \text{ V}$	Reinforced $U_{LL} = 2000 \text{ V}$

Motor bearing currents

It is generally recommended that motors of a rating 150 hp [110 kW] or higher operating via adjustable frequency drives should have NDE (Non-Drive End) insulated bearings installed to eliminate circulating bearing currents due to the physical size of the motor. To minimize DE (Drive End) bearing and shaft currents proper grounding of the drive, motor, driven machine, and motor to the driven machine is required. Although failure due to bearing currents is low and very dependent on many different items, for security of operation the following are mitigation strategies which can be implemented.

Standard Mitigation Strategies:

1. Use an insulated bearing
2. Apply rigorous installation procedures
 - Ensure the motor and load motor are aligned
 - Strictly follow the EMC installation guidelines
 - Reinforce the PE so the high frequency impedance is lower in the PE than the input power leads.
 - Provide a good high frequency connection between the motor and the adjustable frequency drive for instance by shielded cable which has a 360° connection in the motor and the adjustable frequency drive.
 - Make sure the impedance from adjustable frequency drive to building ground is lower than the grounding impedance of the machine. This can be difficult for pumps. Make a direct ground connection between the motor and load motor.

3. Apply conductive lubrication
4. Try to ensure the line voltage is balanced to ground. This can be difficult for IT, TT, TN-CS or Grounded leg systems
5. Use an insulated bearing as recommended by the motor manufacturer (note: Motors from reputable manufacturers will typically have these fitted as standard in motors of this size)

If found to be necessary and after consultation with Xylem:

1. Lower the IGBT switching frequency
2. Modify the inverter waveform, 60° AVM vs. SFAVM
3. Install a shaft grounding system or use an isolating coupling between motor and load
4. Use minimum speed settings, if possible.
5. Use a dU/dt or sinus filter

5.15 Control terminals

5.15.1 Control cable routing

Tie down all control wires to the designed control cable routing as shown in the picture. Remember to connect the shields in a proper way to ensure optimum electrical immunity.

Serial communication bus connection

Connections are made to the relevant options on the control card. For details, see the relevant serial communication bus instruction. The cable must be placed in the provided path inside the adjustable frequency drive and tied down with other control wires.

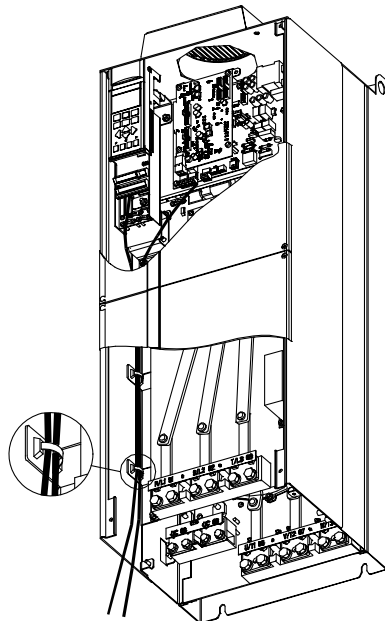

Figure 66: Control card wiring path for the D3. Control card wiring for D1, D2, D4, E1 and E2 use the same path

Installation of 24 Volt external DC supply

Torque: 0.5-0.6 Nm (5 in-lbs)

Screw size: M3

Number	Function
35 (-), 36 (+)	24 V external DC supply

24 V DC external supply can be used as low-voltage supply to the control card and any option cards installed. This enables full operation of the LCP (including parameter setting)

without connection to line power. Please note that a warning of low voltage will be given when 24 V DC has been connected; however, there will be no tripping.



Electrical Hazard:

Use 24 V DC supply of type PELV to ensure correct galvanic isolation (type PELV) on the control terminals of the adjustable frequency drive.

5.15.2 Access to control terminals

All terminals to the control cables are located beneath the LCP. They are accessed by opening the door of the IP21/54 version or removing the covers of the IP00 version.

5.15.3 Control cable and connection

- Isolate control wiring from high power components in the adjustable frequency drive
- If the adjustable frequency drive is connected to a thermistor, for PELV isolation, optional thermistor control wiring must be reinforced/double insulated. A 24 V DC supply voltage is recommended.

Using shielded control cables

Xylem recommends braided shielded/armored cables to optimize EMC immunity of the control cables and the EMC emission from the motor cables.

The ability of a cable to reduce the incoming and outgoing radiation of electric noise depends on the transfer impedance (Z_T). The shield of a cable is normally designed to reduce the transfer of electric noise; however, a shield with a lower transfer impedance (Z_T) value is more effective than a shield with a higher transfer impedance (Z_T).

Transfer impedance (Z_T) is rarely stated by cable manufacturers, but it is often possible to estimate transfer impedance (Z_T) by assessing the physical design of the cable.

Transfer impedance (Z_T) can be assessed on the basis of the following factors:

- The conductivity of the shield material
- The contact resistance between the individual shield conductors
- The shield coverage, i.e., the physical area of the cable covered by the shield - often stated as a percentage value
- Shield type, i.e., braided or twisted pattern

a	Aluminum-clad with copper wire
b	Twisted copper wire or armored steel wire cable
c	Single-layer braided copper wire with varying percentage shield coverage.
d	This is the typical reference cable.
e	Double-layer braided copper wire
f	Twin layer of braided copper wire with a magnetic, shielded/armored intermediate layer Cable that runs in copper tube or steel tube
g	Lead cable with 0.043 in [1.1 mm] wall thickness

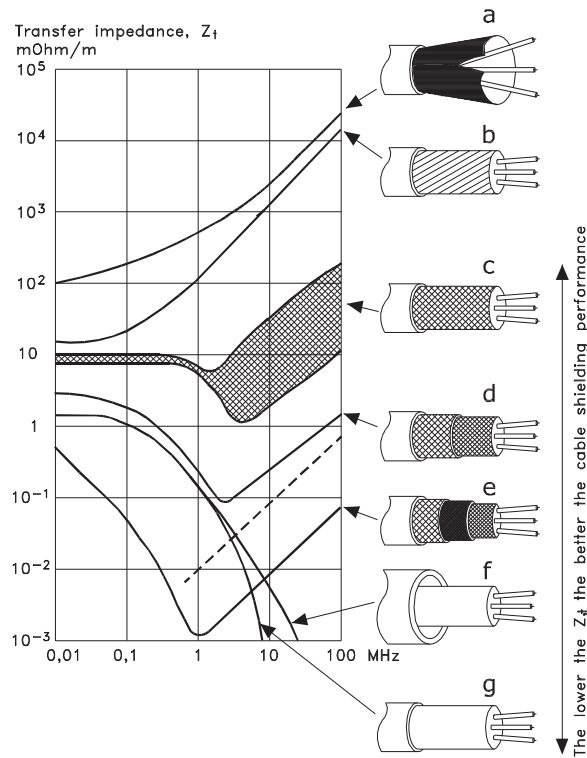

Figure 67: Shielded control cables

Grounding of shielded control cables

Correct screening

The preferred method in most cases is to secure control and serial communication cables with screening clamps provided at both ends to ensure best possible high frequency cable contact.

If the earth potential between the frequency converter and the PLC is different, electric noise may occur that will disturb the entire system. Solve this problem by fitting an equalizing cable next to the control cable. Minimum cable cross section: 6 AWG or 16 mm².

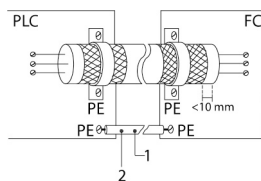

Figure 68: Correct screening

1	Min. 6 AWG or 16 mm ²
2	Equalizing cable

50/60 Hz ground loops

With very long control cables, ground loops may occur. To eliminate ground loops, connect one end of the screen-to-ground with a 100 nF capacitor (keeping leads short).

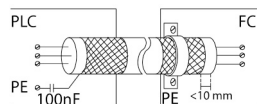

Figure 69: 50/60 Hz ground loops

Avoid EMC noise on serial communication

This terminal is connected to earth via an internal RC link. Use twisted-pair cables to reduce interference between conductors.

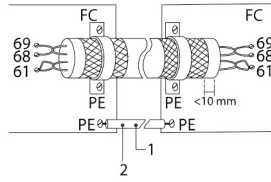

Figure 70: Twisted-pair cables

1	Min. 6 AWG or 16 mm ²
2	Equalizing cable

Alternatively, the connection to terminal 61 can be omitted:

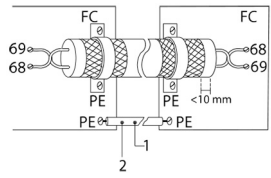

Figure 71: Twisted-pair cables without terminal 61

1	Min. 6 AWG or 16 mm ²
2	Equalizing cable

5.16 Control terminal types

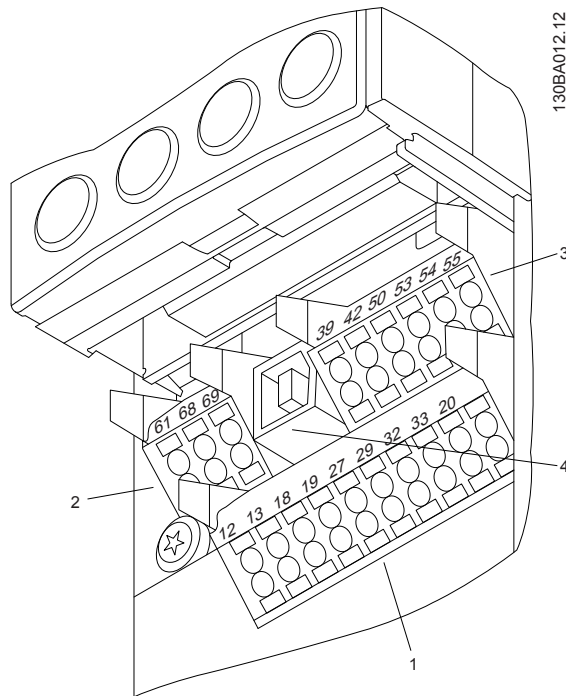

Figure 72: Control terminal locations

- **Connector 1** provides four programmable digital inputs terminals, two additional digital terminals programmable as either input or output, a 24 V DC terminal supply voltage, and a common for optional customer supplied 24 V DC voltage.
- **Connector 2** terminals (+)68 and (-)69 are for an RS-485 serial communications connection.
- **Connector 3** provides two analog inputs, one analog output, 10 V DC supply voltage, and commons for the inputs and output.
- **Connector 4** is a USB port available for use with the MCT 10 Set-up software.
- Also provided are two Form C relay outputs that are in various locations depending upon the frequency converter configuration and size.
- Some options available for ordering with the unit may provide additional terminals. See the manual provided with the equipment option for details and configuration.

Table 7: Terminal descriptions

	Terminal number	Parameter number	Default setting or function	Description
Relay outputs	01, 02, 03	5-40 Relay 1	[160] No Alarm	Form C Relay output. Usable for AC or DC voltages and either resistive or inductive loads. Refer to the relay wiring section for relay contact current and voltage ratings.
	04, 05, 06	5-40 Relay 2	[5] Running	

	Terminal number	Parameter number	Default setting or function	Description
Digital I/O	12, 13	-	+24V DC	24V DC supply voltage. Maximum output current is 200mA total for all 24V loads. Usable for digital inputs and external transducers.
	18	5-10	[8] Start	Start/Stop digital input signal for the drive. Connect input to 24V to start. Open the input to stop. This is a required connection.
	19	5-11	[0] No Operation	Unused digital input. This input can be configured for use as a Pump Protect Warning or Alarm Input. See Pump Protect section to enable the Warning or Alarm associated with this input.
	27	5-12	[0] No Operation	Unused digital input. This input can be configured for use as a Pump Protect Warning or Alarm Input. See Pump Protect section to enable the Warning or Alarm associated with this input.
	29	5-13	[63] No Water/Loss of Prime Restart (CMP3)	Selectable for digital input or output. Default configuration is an output that is configured for use as a No Water/Loss of Prime Restart signal. Refer to the Pump Protection section for details.
	32	5-14	[1] Reset	Digital input. Configured for use as a Reset for the No Water/Loss of Prime Restart function. Refer to the Pump Protection section for details.
	33	5-15	[23] SP1/SP2 Select	Digital input. Configured for use as a Setpoint 1/Setpoint 2 select (SP1/SP2).
	20	-	Common	Common for digital inputs and reference for 24V supply

	Terminal number	Parameter number	Default setting or function	Description
Analog I/O	39	-	AO Common	Common for analog output
	42	6-50	[137] Speed 4-20 mA	Analog output. Default setting is 4-20mA signal (500Ω max) based on motor speed. Range is 0 to max speed indicated in parameter 4-14.
	50	-	+10V DC	10V DC analog supply voltage. 15mA maximum.
	53	6-1*	Transducer feedback	Analog input 53. Default configuration is 300 psi, 4-20mA pressure transducer input.
	54	6-2*	Not Used	Analog input 54
	55	-	AI Common	Common for analog input
Comm.	61	-	Shield Connection	Integrated RC filter for cable shield. ONLY for connecting the shield when experiencing EMC problems.
	68	8-3*	+	RS485 interface +
	69	8-3*	-	RS485 interface -

5.17 Wiring to control terminals

5.17.1 Unplug terminal connectors

Control terminal connectors can be unplugged from the frequency converter for ease of installation.

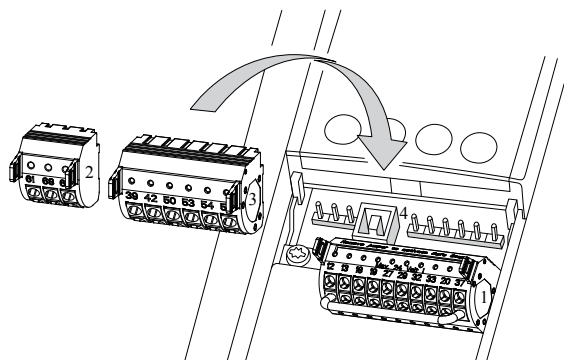

5.17.2 Control terminal connections

Connecting to the control terminals

1. To connect control wiring to the control terminals, do the following:
 - a. Strip the control wire back 9-10mm (0.35-0.40 in)
 - b. Insert a screwdriver (0.4 x 2.5 mm) in the rectangular hole.

- c. Insert the cable in the adjacent circular hole.
 - d. Remove the screwdriver. The wire is now mounted to the terminal.
2. To remove the wire from the terminal:
 - a. Insert a screwdriver (0.4 x 2.5 mm) in the rectangular hole.
 - b. Pull out the cable.

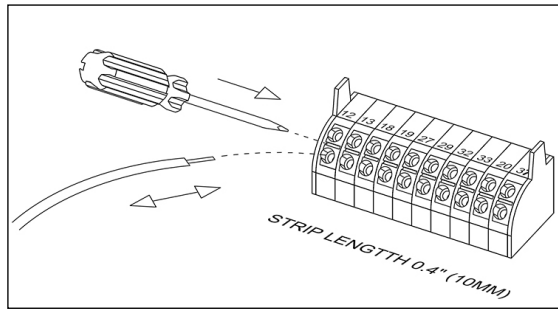

Figure 73: Connecting and disconnecting control wiring

Analog input configuration

If an analog input is used, the analog input configuration switches must be set properly. To set the configuration switches, remove the local control panel and set the appropriate switch as required.

- Remove power from the controller before changing the analog input configuration switches.
- To configure the analog input as a voltage input, set the configuration switch to U.
- Set the configuration switch to I to enable the input as a current input.
- Switch A53 is used to configure analog input 53.
- Switch A54 is used to configure analog input 54.

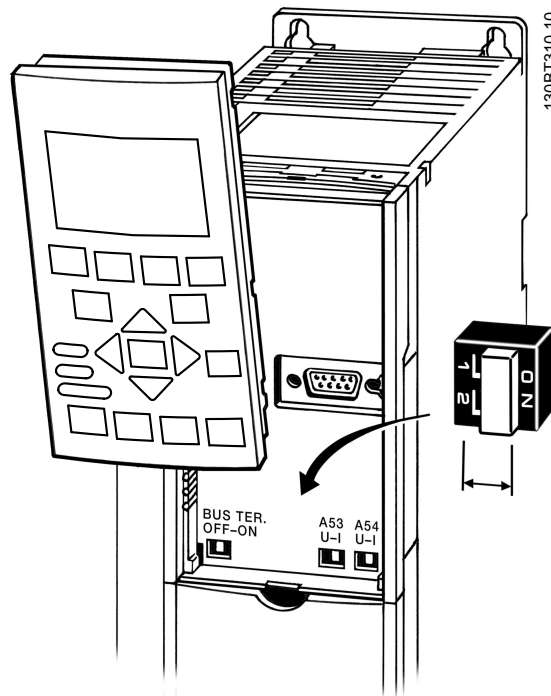

Figure 74: Configuration switch location

**WARNING:**

Some option cards available for the unit may cover these switches and must be removed to change switch settings. Always remove power to the unit before removing option cards.

5.17.3 Control terminal functions

Frequency converter functions are commanded by receiving control input signals.

- Each terminal must be programmed for the function it will be supporting in the parameters associated with that terminal.
- It is important to confirm that the control terminal is programmed for the correct function. See the Local control panel section for detail on accessing parameters and frequency converter section for details on programming.
- The default terminal programming is intended to initiate frequency converter functioning in a single pump, constant pressure operating more.

5.17.4 Analog input 53

The default operating mode of the frequency converter is Single Pump, constant pressure mode. In this mode a feedback signal from a transducer, PLC or other device is required on Analog Input 53 (AI 53). The default settings for AI 53 allow the use of a 300psi, 4-20mA pressure transducer.

When using the supplied pressure transducer:

1. Connect the feedback (white wire) from the transducer cable to AI 53
2. Connect the power wire (brown wire) to terminal 12 or 13 (24V dc)
3. In cases where the transducer is mounted on ungrounded piping, connect the drain (bare wire) to the spring loaded cable strain relief clamps found below the control terminals.

5.17.5 Jumper terminals 12 and 18

The frequency converter has been configured to require a start command on terminal 18. To apply a start signal connect the device used to control starting of the drive or a jumper wire between terminals 18 (DI 18, parameter 5-10) and 12 (24V dc). A start command is given to the controller when terminal 18 is connected to 24V.

5.17.6 Serial communication

RS-485 is two-wire bus interface compatible with multi-drop network topology. For example, nodes can be connected as a bus, or via drop cables from a common trunk line. A total of 32 nodes can be connected to one network segment. Repeaters divide network segments. Note that each repeater functions as a node within the segment in which it is installed. Each node connected within a given network must have a unique node address, across all segments. Terminate each segment at both ends, using either the termination switch (BUS TER./S801) of the frequency converters or a biased termination resistor network. Always use screened twisted pair (STP) cable for bus cabling, and always follow good common installation practice.

Low-impedance ground (earth) connection of the screen at every node is important, including at high frequencies. Thus, connect a large surface of the screen to ground (earth), for example with a cable clamp or a conductive cable gland. It may be necessary to apply potential-equalizing cables to maintain the same ground (earth) potential throughout the network. Particularly in installations with long cables.

To prevent impedance mismatch, always use the same type of cable throughout the entire network. When connecting a motor to the frequency converter, always use screened motor cable.

Table 8: Cable information

Cable	Screened twisted pair (STP)
Impedence	120 Ω
Max. cable length [m]	1200 including drop lines 500 station-to-station

5.18 Common terminal wiring configurations

Relay wiring

Each controller has two programmable form C relay outputs. The relay terminals are located in various locations on the controller depending on the frame size.

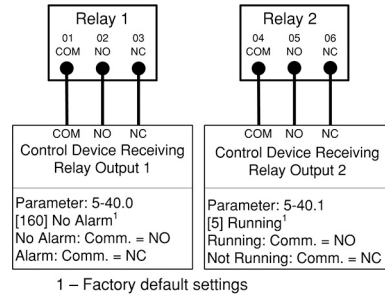

1 – Factory default settings

Figure 75: Relay terminal wiring

Table 9: Relay terminal ratings

Programmable relay outputs	2
Relay 01 Terminal number	1-3 (break), 1-2 (make)
Maximum terminal load (AC-1)1) on 1-2 (NO) (Resistive load)2)3)	400 V AC, 2A
Maximum terminal load (AC-15)1) on 1-2 (NO) (Inductive load @ cosφ 0.4)	240 V AC, 0.2A
Maximum terminal load (DC-1)1) on 1-2 (NO) (Resistive load)	80 V DC, 2A
Maximum terminal load (DC-13)1) on 1-2 (NO) (Inductive load)	24 V DC, 0.1A
Maximum terminal load (AC-1)1) on 1-3 (NC) (resistive load)	240 V AC, 2A
Maximum terminal load (AC-15)1) on 1-3 (NC) inductive load @ cosφ 0.4)	240 V AC, 2A
Maximum terminal load (DC-1)1) on 1-3 (NC) (resistive load)	50 V DC, 2A
Maximum terminal load (DC-13)1) on 1-3 (NC) (inductive load)	24 V DC, 0.1A
Minimum terminal load on 1-3 (NC), 1-2 (NO)	24 V DC 10mA, 24 V AC 20mA
Environment according to EN 60664-1	overvoltage category III/pollution degree 2
Relay 02 Terminal number	4-6 (break), 4-5 (make)
Maximum terminal load (AC-2)1) on 4-5 (NO) (resistive load)2,3)	400 V AC, 2A
Maximum terminal load (AC-15)1) (Inductive load @ cosφ 0.4)	240 V AC, 0.2A
Maximum terminal load (DC-1)1) on 4-5 (NO) (Resistive load)	80 V DC, 2A
Maximum terminal load (DC-13)1) on 4-5 (NO) (Inductive load)	24 V DC, 0.1A
Maximum terminal load (AC-1)1) on 4-6 (NC) (Resistive load)	240 V AC, 2A
Maximum terminal load (AC-15)1) on 4-6 (NC) (Inductive load @ cosφ 0.4)	240 V AC, 0.2A
Maximum terminal load (DC-1)1) on 4-6 (NC) (Resistive load)	50 V DC, 2A
Maximum terminal load (DC-13)1) on 4-6 (NC) (Inductive load)	24 V DC, 0.1A
Minimum terminal load on 1-3 (NC), 1-2 (NO), 4-6 (NC), 4-5 (NO)	24 V DC 10mA, 24 V AC 20mA

Environment according to EN 60664-1

overvoltage category III/pollution degree 2

Wiring for factory default setup

This configuration utilizes the controller factory default settings for I/O. The factory default settings for ITSC are configured for a single pump, constant pressure application with a 300 psi, 4-20mA pressure transducer wired to AI 53. A jumper wire is needed between terminals 29 and 32 to enable the No Water/Loss of Prime Restart function. A Start signal is applied on Digital Input 18. The controller will receive a Start command when DI 18 is connected to 24V. There are no parameters that need to be adjusted for this configuration. Refer to Commissioning section for details on configuring the controller and changing application settings.



CAUTION:

When a Start (Closed) signal is present on DI18, the controller can start the pump/motor at any time without warning. Set DI18 to Stop (Open) or press the [Off] operation key before using the Genie. Apply the Start signal to the controller only when pump/motor operation is desired.

NOTICE:

The factory default settings are configured to require a start signal wired to DI18 as shown below.

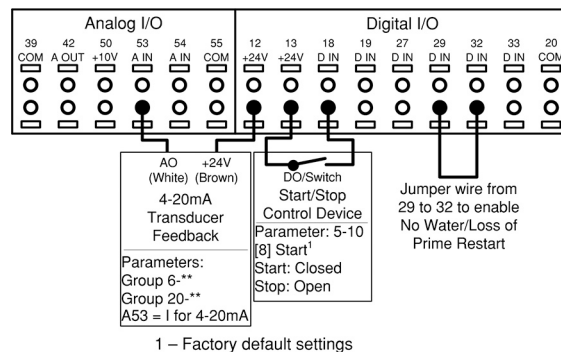
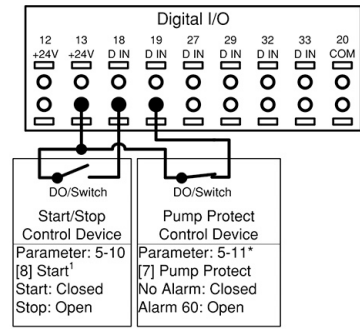

Figure 76: Required terminal connections for use with factory default settings

Pump protect

A Pump Protect function can be used to turn off the controller and issue an alarm (Pump Protect Alarm 60) when system pressures, temperatures, levels, etc. are outside of the normal operating range for the system. The Pump Protect function can be configured on digital input 19 and digital input 27. These inputs can be controlled by an external device such as a suction pressure switch, an over pressure switch, a temperature switch, a differential pressure switch, etc. The device chosen should be normally closed. The [22-00] *Pump Protect Delay* parameter can be configured to delay the onset of the Pump Protect Alarm to prevent nuisance tripping. When the input is disconnected from the 24V supply, the delay timer will start. If the input remains disconnected for the time indicated in [22-00] *Pump Protect Delay*, the controller stops the motor and issues *Alarm 60 Pump Protect*. If a Pump Protect Alarm is issued, the controller will attempt to restart if the [14-20] *Reset Mode* parameter and the [14-21] *Automatic Restart Time* parameter are set to allow automatic restarting. To prevent an automatic restart set the [14-20] *Reset Mode* to Manual Reset. Note that the [14-20] *Reset Mode* parameter affects all other Alarms that are not listed as a Trip Lock Alarm. Refer to the Warnings/Alarm Messages section for details.

NOTE: This function can be enabled using the Start-Up Genie.



1 – Factory default settings
 * – DI 27 can also be configured for the Pump Protect Function. To use DI 27, connect the control device between 13 and 27. Set parameter 5-12 to [7] Pump Protect.

Figure 77: Connections for adding Pump Protect

Table 10: Parameter settings for enabling a Pump Protect Alarm on DI19

Parameter number	Parameter description	Set to
5-11*	Terminal 19 Digital Input	Pump Protect
22-00	Pump Protect Delay	Set to the desired delay time. If set to 10 seconds, the Pump Protect Alarm will be issued 10 seconds after the input is disconnected from 24V. The input must remain disconnected for the entire delay time for the alarm to be issued.
14-20	Reset Mode	Set to the desired number of automatic resets. If a fault occurs more than this setting, a manual reset is required. Set to Manual Reset if no resets are allowed. Default setting is: Automatic reset x 3.
14-21	Automatic Restart Time	This is the time between when an alarm/warning is issued and when the controller attempts the next restart. Default setting is 30 seconds.

* To configure DI 27, set 5-12 to Pump Protect.

Configuring an additional transducer feedback

An additional transducer can be added to the system to work with closed loop control or for external monitoring. The additional transducer can be either a voltage output or current output transducer. The additional transducer can be added to the unused analog input (AI 53 or AI 54). The wiring below shows the required connections for an additional transducer on AI 54.

A common use of two pressure transducer feedback signals is to take the difference between the signals to create a differential pressure transducer. To implement a differential pressure transducer with 2 pressure transducers, set parameter [20-20] Feedback Function to Difference. The controller will calculate the feedback value as Feedback 1 Source [20-00] - Feedback 2 Source [20-03]. Be sure to set all unused feedback sources to No Function (parameters 20-00, 20-03 or 20-06). The parameter listing that follows shows how to configure the additional transducer.

- Analog inputs can be configured using the Start-Up Genie.
- Be sure to properly set the analog input configuration switch prior to using the analog input. Refer to the Analog input configuration (Switches A53 and A54) for details.

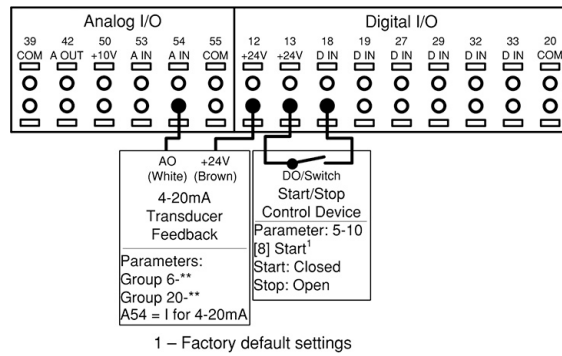

Figure 78: Connections for adding 4-20 mA transducer feedback to AI 54

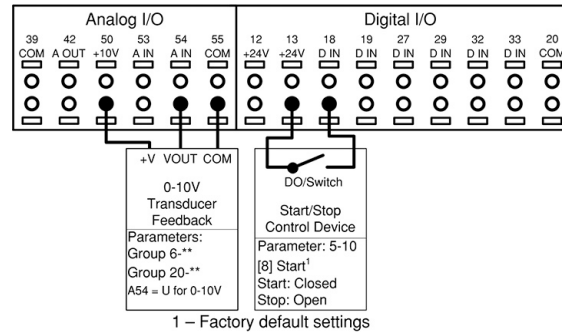

Figure 79: Connections for adding 0-10 V transducer feedback to AI 54

In order to set up the controller for closed loop control based on the feedback from an external transducer, set the following parameters:

Table 11: Parameter settings to enable an additional transducer on AI 54

Parameter Number	Parameter Description	Set To
6-24*	Terminal 54 Low Ref./Feedb. Value	Minimum transducer feedback value. For example, for a 0-300psi transducer, set to 0.
6-25*	Terminal 54 High Ref./Feedb. Value	Maximum transducer feedback value. For example, for a 300psi transducer, set to 300.
6-27*	Terminal 54 Sensor Fault	Enabled
20-03	Feedback 2 Source	Analog Input 54*
20-05	Feedback 2 Source Unit	Units for the second feedback source. For a differential pressure transducer, use the same units as found in 20-02, psi is default
20-12	Reference/Feedback Unit	Select as appropriate for application. For example, set to psi when using pressure feedback.
20-13	Minimum Reference/Feedback	Minimum transducer feedback value. For example, for a 0-300psi transducer, set to 0.
20-14	Maximum Reference/Feedback	Maximum transducer feedback value. For example, for a 300psi transducer, set to 300.

* To use AI 53, configure parameters 6-14, 6-15, 6-17

Table 12: Parameters for an additional transducer used for monitoring

Parameter number	Description	Set to
0-24	Display Line 3 Large	Ext. 1 Feedback [Unit]
21-14	Ext. 1 Feedback Source	Analog Input 54*
21-10	Ext. 1 Ref./Feedback Unit	Select as appropriate for application. For example, set to psi when using a pressure transducer.
21-11	Ext. 1 Minimum Reference	Minimum transducer feedback value. For example, for a 0-300psi transducer, set to 0 psi.
21-12	Ext. 1 Maximum Reference	Maximum transducer feedback value. For example, for a 300 psi DP transducer, set to 300 psi.
6-24*	Terminal 54 Low Ref./Feedb. Value	Minimum transducer feedback value. For example, for a 0-300 psi transducer, set to 0.
6-25*	Terminal 54 High Ref./Feedb. Value	Maximum transducer feedback value. For example, for a 300 psi transducer, set to 300.
6-27*	Terminal 54 Sensor Fault	Disabled

* To use AI 53, configure parameters 6-14, 6-15, 6-17 and set 21-14 to Analog Input 53

Speed control through an analog input

The controller can be configured for speed control through an analog input. The controlling source can be either an external control device such as a PLC, BMS (building management system) or potentiometer. The output from the external control device can be either a voltage or current output signal. Be sure to set the analog input configuration switches based on the type of output signal. The diagrams below show the connections for an external speed command.

- Speed control mode can be configured using the Start-Up Genie.

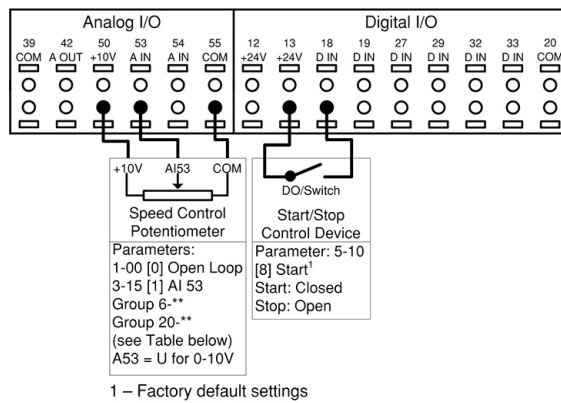

Figure 80: Connections for speed control with external potentiometer

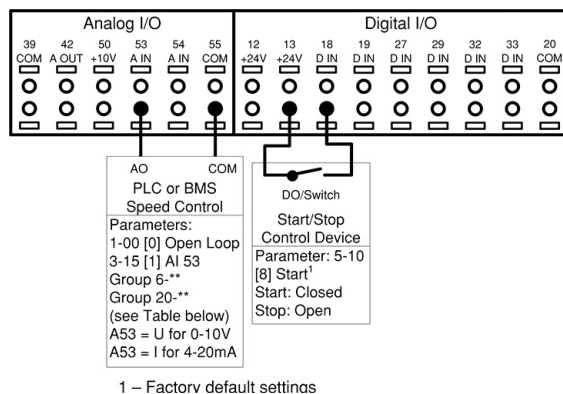

Figure 81: Connections for speed control with PLC or BMS

Table 13: Parameters for speed control from external potentiometer, PLC or BMS

Parameter number	Description	Set to
1-00	Configuration Mode	Open Loop
3-15	Reference 1 Source	Analog Input 53
3-02	Minimum Reference	Set to value corresponding to desired speed at the minimum reference
3-03	Maximum Reference	Set to value corresponding to desired speed at the maximum reference
3-15	Reference 1 Source	Analog Input 53***
6-10*	Terminal 53 Low Voltage*	0 V
6-11*	Terminal 53 High Voltage*	10 V
6-12**	Terminal 53 Low Current**	4 mA
6-13**	Terminal 53 High Current**	20 mA
6-14	Terminal 53 Low Ref./Feedb. Value	Set to value corresponding to the commanded speed at the low voltage/current.
6-15	Terminal 53 High Ref./Feedb. Value	Set to value corresponding to the commanded speed at the high voltage/current.
6-17	Terminal 53 Sensor Fault	Disabled
2000	Feedback 1 Source	No Function

* Set switch A53 = U, parameters 612 and 613 are hidden when A53 = U.

** Set switch A53 = I, parameters 610 and 611 are hidden when A53 = I

*** Set to use AI54, set to Analog Input 54, configure parameters 620/1 or 622/3, 642, 625 and 62.

Control from external PLC/BMS through Analog Input

The controller can be configured to accept either the process variable (e.g. actual pressure) or setpoint from an external control source such as a PLC or BMS controller through an analog input. The output from the external control device can be either a voltage or current output signal. Be sure to set the analog input configuration switches based on the type of output signal. When the process variable is supplied by the external controller, the wiring connections are the same as used with the connections for speed control from an external device through an analog input. When the setpoint or reference is supplied to the controller from the external device both a transducer and the external control device supplying the setpoint need to be connected to the controller. Refer to the wiring diagram below. The parameter settings for this configuration are shown below.

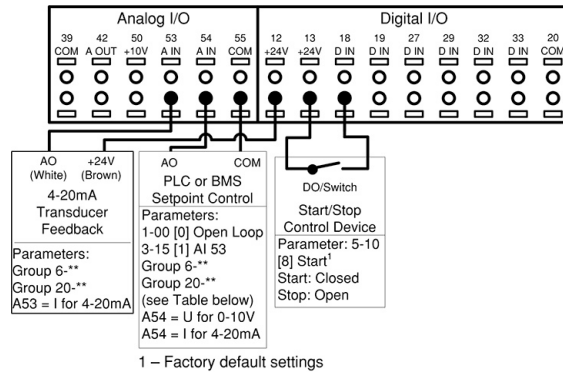

Figure 82: Connections for setpoint control through an external device

Duplex control wiring

The controller can be configured to operate in a duplex control system having 2 controllers and 2 variable speed pumps. In this configuration pumps can be staged and destaged as needed and the lead pump can be alternated. When both pumps are on they operate at the same frequency. To configure the controller for this type of system, a specific wiring configuration is required. The diagram below shows the wiring required to implement the duplex control system.

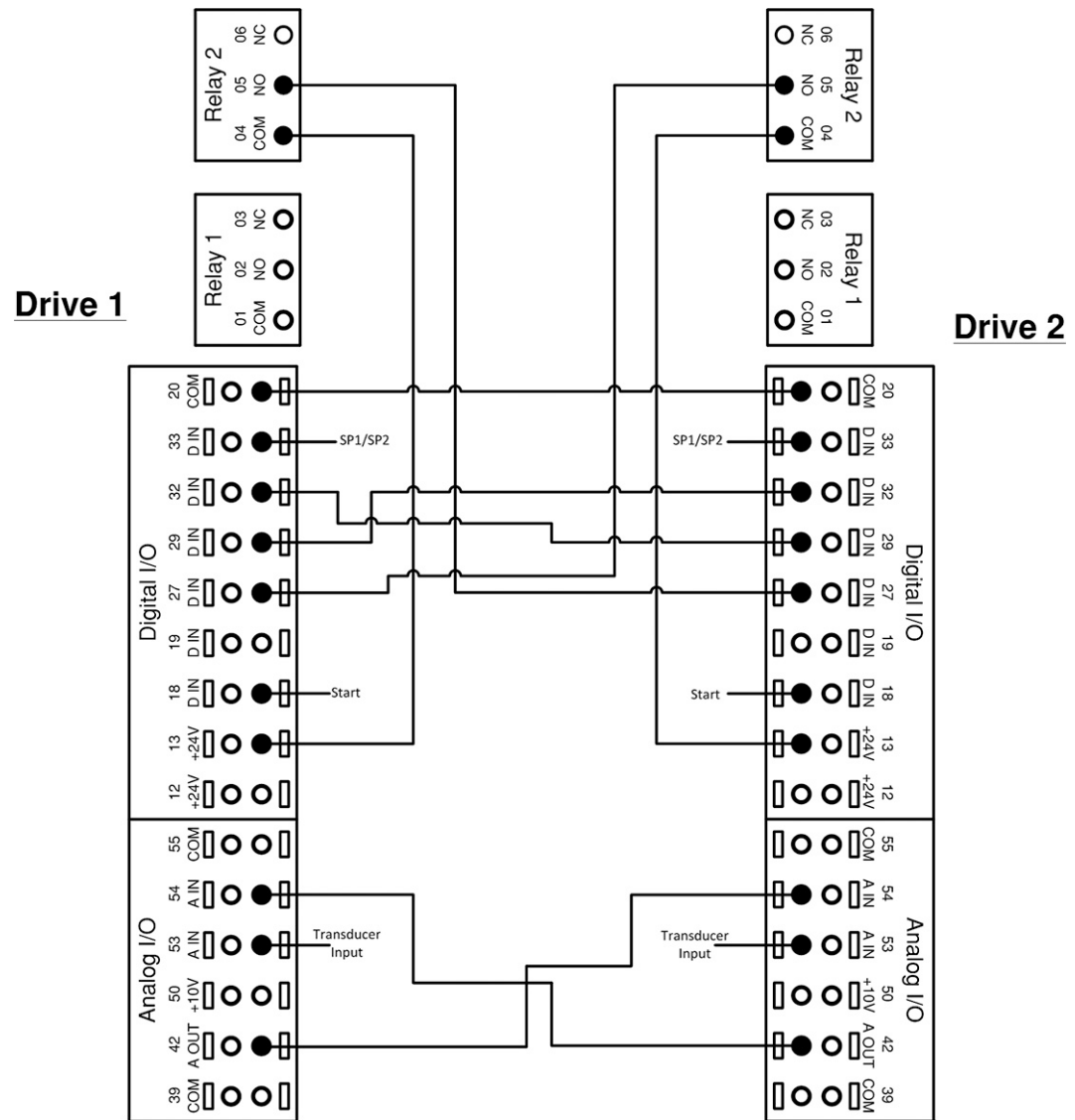

Figure 83: Duplex wiring

Duplex Control Mode requires a specific set of parameters in order to ensure proper functionality. The Start-Up Genie must be used to configure the Duplex Control Mode. See the Commissioning section for details.

Control from external PLC/BMS through communications port

A BMS or PLC can be connected to the control through the communications port. In this configuration, the BMS or PLC can control the drive by overriding the setpoint, supplying the process variable or by providing a speed command to the drive. Control cables must be braided screened/shielded and the screen must be connected by means of a cable clamp at the controller and at the BMS/PLC. Refer to Using Screened Control Cables for details on installing shielded/screened cables. The parameter list in the table below shows parameters used to configure communication for two common protocols, Modbus RTU and BACnet. The parameter list in the second table below shows parameters that determine the control source for certain drive functions. Use these parameters to determine whether digital inputs or the BMS/PLC has control of the function.

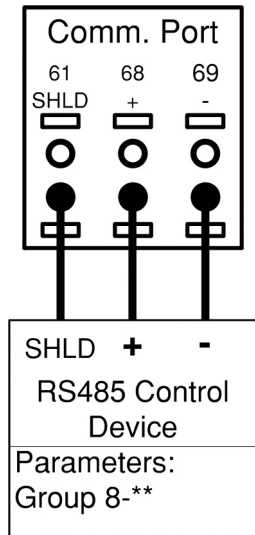

Figure 84: Connections for external control source connected through comm. port

Table 14: Parameter settings for Modbus RTU and BACnet protocols

Parameter Number	Parameter Description	Protocol	
		Modbus RTU	BACnet
8-02	Control Source	FC Port	FC Port
8-30	Protocol	Modbus RTU	BACnet
8-31	Address	1	1
8-32	Baud Rate	19200	9600
8-33	Parity/Stop bit	Even Parity, 1 Stop bit	No Parity, 1 Stop bit
8-34	Estimated cycle time	0 ms	0 ms
8-35	Minimum Response Delay	10 ms	10 ms
8-36	Maximum Response Delay	5000 ms	5000 ms
8-37	Maximum Inter-Char Delay	0.86 ms	25 ms

Table 15: Parameters determining control source for controller functions

Parameter number	Description	Set to
8-01	Control Site	Determines the location of the control source. Set to Digital and ctrl.word to use both serial bus and digital input control. Set to Digital only to use only the digital inputs. Set to Controlword only to use only the serial bus.
8-50	Coasting Select	Determines the control location of the coasting (stop) function. Set to Digital input to use a digital input only. Set to Bus to use only the serial bus only. Set to Logic AND to use the serial bus AND a digital input. Set to Logic OR to use the serial bus OR a digital input.
8-53	Start Select	Determines the control location of the start command. Set to Digital input to use a digital input only. Set to Bus to use only the serial bus only. Set to Logic AND to use the serial bus AND a digital input. Set to Logic OR to use the serial bus OR a digital input.

Parameter number	Description	Set to
8-55	Set-up Select*	Determines the control location of the set-up selection function. Set to Digital input to use a digital input only. Set to Bus to use only the serial bus only. Set to Logic AND to use the serial bus AND a digital input. Set to Logic OR to use the serial bus OR a digital input.
8-56	Preset Reference Select*	Determines the control location of the preset reference selection function. Set to Digital input to use a digital input only. Set to Bus to use only the serial bus only. Set to Logic AND to use the serial bus AND a digital input. Set to Logic OR to use the serial bus OR a digital input.

* The Set-up Select and Preset Reference Select functions are used to control other pre-configured functions in the controller. To avoid interfering with these functions, it is recommended to control this function via digital inputs.

5.19 Local control panel

The controller is equipped with a local control panel (LCP). The LCP combines the status screen and keypad found on the front of the controller. The LCP is the user interface to the controller. The LCP allows the user to perform various functions such as:

- Start, stop and control speed with the keypad when in local/Hand mode
- View and display the status of the controller, pump and system
- Provides access to all parameters and start up functions
- Manually reset the controller after a fault
- Perform parameter backup

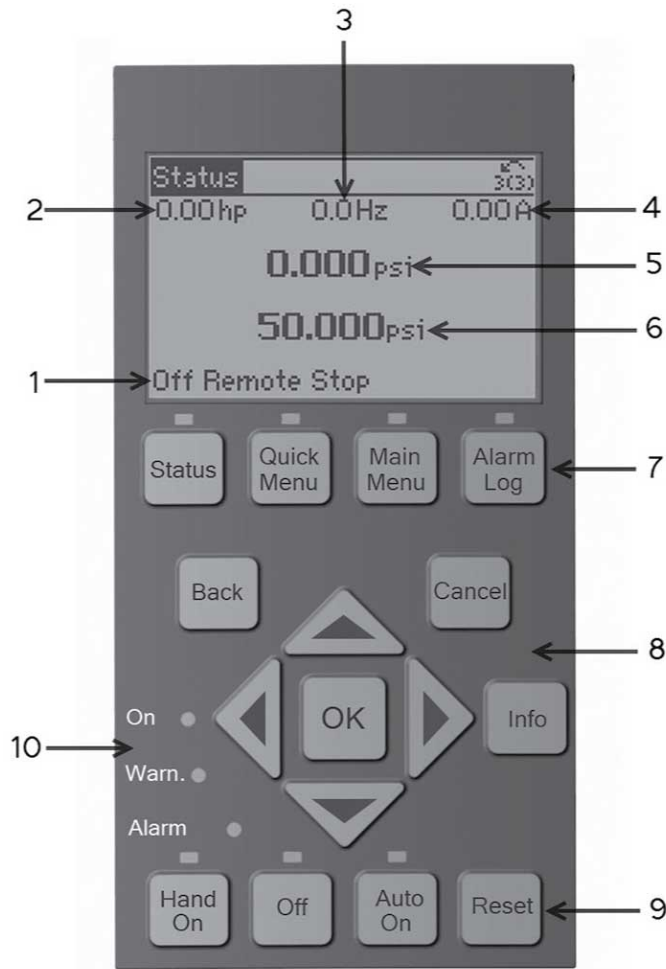

Figure 85: Default configuration

1. Controller Status
2. Motor HP (Parameter 0-20)
3. Motor Frequency (Parameter 0-21)
4. Motor Current (Parameter 0-22)
5. Feedback/Actual Pressure or process variable (Parameter 0-23)
6. Setpoint (Parameter 0-24)
7. Menu keys
8. Navigation keys
9. Operation keys
10. Status lights

The parameters shown are the factory default settings. To display other values, modify parameters 0-20, 0-21, 0-22, 0-23, or 0-24.

Controller status

The controller status line shows operational information about the controller.

The first word in the status line shows the Operation Mode. The table below defines the Operation Mode status.

Off	The controller does not react to any control signal until [Auto On] is pressed.
Auto On	The controller is controlled from the control terminal and/or the serial communication.

Hand On	The controller can be controlled by the navigation keys on the LCP. Stop commands, reset, reversing, DC brake, and other signals applied to the control terminals can override local control.
---------	---

The second word in the status line shows the Reference Site.

Remote	The speed reference is given from external signals, serial communication, or internal preset references.
Local	The controller converter uses [Hand On] control or reference values from the LCP.

The third word in the status line shows the Operation Status.

AC Brake	AC Brake was selected in <i>2-10 Brake Function</i> . The AC brake over-magnetizes the motor to achieve a controlled slow down.
AMA finish OK	Automatic motor adaptation (AMA) was carried out successfully.
AMA ready	AMA is ready to start. Press [Hand On] to start.
AMA running	AMA process is in progress.
Braking	The brake chopper is in operation. Generative energy is absorbed by the brake resistor.
Braking max.	The brake chopper is in operation. The power limit for the brake resistor defined in <i>2-12 Brake Power Limit (kW)</i> has been reached.
Coast	<ul style="list-style-type: none"> Coast inverse was selected as a function for a digital input (parameter group <i>5-1* Digital Inputs</i>). The corresponding terminal is not connected. Coast activated by serial communication.
Ctrl. Ramp-down	Control Ramp-down was selected in <i>14-10 Mains Failure</i> . <ul style="list-style-type: none"> The mains voltage is below the value set in <i>14-11 Mains Voltage at Mains Fault</i> The controller ramps down the motor using a controlled ramp down
Current high	The controller output current is above the limit set in <i>4-51 Warning Current High</i> .
Current Low	The controller output current is below the limit set in <i>4-52 Warning Speed Low</i> .
DC Hold	DC hold is selected in <i>1-80 Function at Stop</i> and a stop command is active. The motor is held by a DC current set in <i>2-00 DC Hold/Preheat Current</i> .
DC Stop	The motor is held with a DC current (<i>2-01 DC Brake Current</i>) for a specified time (<i>2-02 DC Braking Time</i>). <ul style="list-style-type: none"> DC Brake is activated in <i>2-03 DC Brake Cut In Speed [RPM]</i> and a Stop command is active. DC Brake (inverse) is selected as a function for a digital input (parameter group <i>5-1* Digital Inputs</i>). The corresponding terminal is not active. The DC Brake is activated via serial communication.
Feedback high	The sum of all feedbacks is above the feedback limit set in <i>4-57 Warning Feedback High</i> .
Feedback low	The sum of all actives is below the feedback limit set in <i>4-56 Warning Feedback Low</i> .

Freeze output	<p>The remote reference is active, which holds the present speed.</p> <ul style="list-style-type: none"> Freeze output was selected as a function for a digital input (parameter group 5-1* <i>Digital Inputs</i>). The corresponding terminal is active. Speed control is only possible via the terminal functions Speed Up and Speed Down. Hold ramp is activated via serial communication.
Freeze output request	A freeze output command has been given, but the motor will remain stopped until a run permissive signal is received.
Freeze Reference	<i>Freeze Reference</i> was chosen as a function for a digital input (parameter group 5-1* <i>Digital Inputs</i>). This corresponding terminal is active. The controller saves the actual reference. Changing the reference is now only possible via terminal functions Speed Up and Speed Down.
Jog request	A jog command has been given, but the motor will be stopped until a run permissive signal is received via a digital input.
Jogging	<p>The motor is running as programmed in 3-19 <i>Jog Speed [RPM]</i>.</p> <ul style="list-style-type: none"> Jog was selected as function for a digital input (parameter group 5-1* <i>Digital Inputs</i>). The corresponding terminal (e.g. Terminal 29) is active. The Jog Function is activated via the serial communication. The Jog function was selected as a reaction for a monitoring function (e.g. No signal). The monitoring function is active.
Motor check	In 1-80 <i>Function at Stop, Motor Check</i> was selected. A stop command is active. To ensure that a motor is connected to the controller, a permanent test current is applied to the motor.
OVC control	<i>Overvoltage</i> control was activated in 2-17 <i>Overvoltage Control, [2] Enabled</i> . The connected motor is supplying the controller with generative energy. The overvoltage control adjusts the V/Hz ratio to run the motor in controlled mode and to prevent the controller from tripping.
PowerUnit Off	(For controllers with an external 24 V power supply installed only.) Mains supply to the controller is removed, but the control card is supplied by the external 24 V.
Protection md	<p>Protection mode is active. The unit has detected a critical status (an overcurrent or overvoltage).</p> <ul style="list-style-type: none"> To avoid tripping, switching frequency is reduced to 4 kHz. If possible, protection mode ends after approximately 10 s Protection mode can be restricted in 14-26 <i>Trip Delay at Inverter Fault</i>

QStop	The motor is decelerating using <i>3-81 Quick Stop Ramp Time</i> . <ul style="list-style-type: none"> • <i>Quick stop inverse</i> was chosen as a function for a digital input (parameter group <i>5-1* Digital Inputs</i>). The corresponding terminal is not active. • The quick stop function was activated via serial communication.
Ramping	The motor is accelerating/decelerating using the active Ramp Up/Down. The reference, a limit value or a standstill is not yet reached.
Ref. high	The sum of all active references is above the reference limit set in <i>4-55 Warning Reference High</i> .
Ref. low	The sum of all active references is below the reference limit set in <i>4-54 Warning Reference Low</i> .
Run on ref.	The controller is running in the reference range. The feedback value matches the setpoint value.
Run request	A start command has been given, but the motor is stopped until a run permissive signal is received via digital input.
Running	The motor is driven by the controller.
Sleep mode	The energy saving function is enabled. This means that at present the motor has stopped, but that it will restart automatically when required.
Speed high	Motor speed is above the value set in <i>4-53 Warning Speed High</i> .
Speed low	Motor speed below the value set in <i>4-52 Warning Speed Low</i> .
Standby	In Auto On mode, the controller will start the motor with a start signal from a digital input or serial communication.
Start delay	In <i>1-71 Start Delay</i> , a delay starting time was set. A start command is activated and the motor will start after the start delay time expires.
Start fwd/rev	Start forward and start reverse were selected as functions for two different digital inputs (parameter group <i>5-1* Digital Inputs</i>). The motor will start in forward or reverse depending on which corresponding terminal is activated.
Stop	The controller has received a stop command from the LCP, digital input or serial communication.
Trip	An alarm occurred and the motor is stopped. Once the cause of the alarm is cleared, the controller can be reset manually by pressing [Reset] or remotely by control terminals or serial communication.
Trip lock	An alarm occurred and the motor is stopped. Once the cause of the alarm is cleared, power must be cycled to the controller. The controller can then be reset manually by pressing [Reset] or remotely by control terminals or serial communication.

LCP parameters

The display configuration shown above represents the default settings. Items 2-6 can be adjusted to display other values. To display other values, modify parameters 0-20, 0-21, 0-22, 0-23 or 0-24 which correspond to 2, 3, 4, 5 and 6 respectively.

Menu keys



Table 16: Function description of menu keys

Key	Function
Status	<p>Pressing the [Status] key toggles between different status screens. There are three different status screens; five readouts (default), four line readouts or Smart Logic Control.</p> <ul style="list-style-type: none"> • Use the [Status] key for selecting the mode of the LCP or for changing back to Status Display mode from any other menu. • The LCP display contrast can also be adjusted by pressing [Status] plus [▲] or [▼] to adjust the display brightness.. • The symbol in the upper right corner of the display shows the direction of motor rotation (arrow), which set-up is active (number) and which is being programmed (number in parenthesis).
Quick Menu	<p>Pressing the [Quick Menu] key provides access to a set of submenus that allows easy access to some common parameters as well as the Start-Up Genie. The Quick Menu consists of My Personal Menu, Quick Set-up, Function Set-up, Start-Up Genie, changes made and Loggings.</p>
Main Menu	<p>Pressing the [Main Menu] key allows access to the complete parameter set. Press [Main Menu] twice to access the top level index. Press [Main Menu] once to return to the last location accessed. Press and hold [Main Menu] for 5 seconds provides access to the Parameter Shortcut. The Parameter shortcut allows the user to enter a parameter number to give direct access to that parameter.</p>
Alarm Log	<p>The [Alarm Log] key allows access to the 5 latest alarms numbers A1-A5. To obtain details about an alarm, use the arrow keys to highlight the alarm number and press OK.</p>

Navigation keys

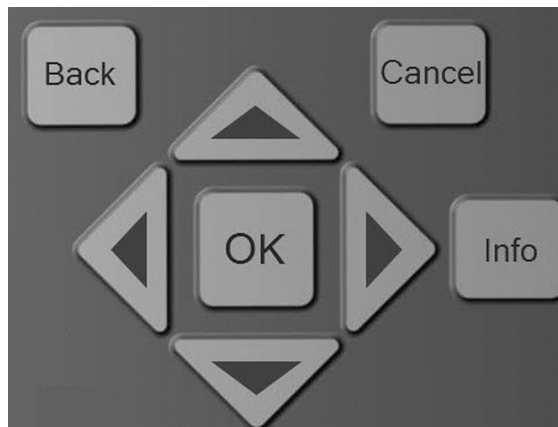

Table 17: Navigation keys functions

Key	Function
Back	Pressing the [Back] key reverts to the previous step or layer in the navigation structure.
Cancel	Pressing the [cancel] button will cancel the last change or command as long as the display has not been changed.
Info	Pressing the [Info] button will display information about a command, parameter, or function in any display window. [Info] provides detailed information when needed. Exit the Info mode by pressing either [Info], [Back], or [Cancel].
OK	[OK] is used for choosing a parameter marked by the cursor and for enabling the change of a parameter.
Arrows	The four navigation arrows are used to navigate between the different choices available in [Quick Menu], [Main Menu] and Alarm Log]. Use these keys to move the cursor.

Table 18: Indicator lights functions

Light	Indicator	Function
Green	ON	The ON light activates when the controller receives power from mains voltage, a DC bus terminal, or an external 24 V supply.
Yellow	WARN	When warning conditions are met, the yellow WARN light comes on and text appears in the display area identifying the problem.
Red	ALARM	A fault condition causes the red alarm light to flash and an alarm text is displayed/

Operation keys

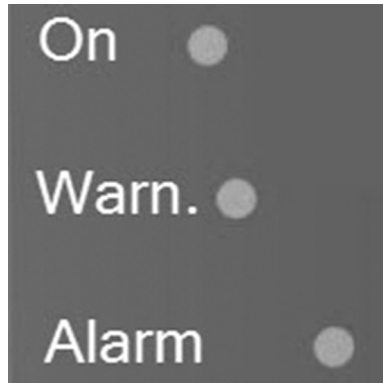

Table 19: Operation keys functions

Hand On	<p>The [Hand On] key enables control of the drive via the LCP interface. Pressing [Hand On] also starts the motor and the speed can be manually adjusted using the arrow keys. The [Hand On] key can be enabled or disabled via parameter 0-40 [Hand On] key on LCP. If [Hand On] is active the drive can be stopped by:</p> <ul style="list-style-type: none"> • Start signal on DI 18 • The [Off] button • Stop command from serial communication
Off	<p>Pressing the [Off] key will stop the motor. The [Off] key can be enabled or disabled via parameter 0-41 [Off] key on LCP. If no external stop function is selected and the [Off] key is disabled, the motor can only be stopped by disconnecting the mains supply.</p>

Auto On	Pressing the [Auto On] key enables the drive to be controlled via the control terminals and/or serial communication. When a start signal is applied on the control terminals and/or serial communication, the drive will start. This key can be enabled or disabled via 0-42 [Auto On] key on LCP.
Reset	The [Reset] key is used for resetting the controller after an alarm (trip). The key can be enabled or disabled via parameter 0-43 [Reset] key on LCP.

Status lights



If certain threshold values are exceeded, the alarm and/or Warning (Warn.) LED will turn on. If an alarm or warning is active, a status or alarm text will appear on the control panel.

- Yellow Warn. LED: Indicates a warning is active.
- Red Flashing Alarm LED: Indicates an alarm is active.

The On LED is activated when the controller receives power.

- Green On LED: Control section is powered and working.

Parameter backup

Parameter settings are stored internally in the controller. The parameters can be uploaded to the LCP for backup or to easily transfer the parameter settings from one controller to another controller. A factory reset does not change the data stored in the LCP.

NOTE: Parameter data can be uploaded to the LCP through the use of the Start-Up Genie. Simply select *Copy to LCP* from the setup selection menu at the beginning of the Genie.

To upload parameters to the LCP without the use of the Start-Up Genie follow the following procedure:

1. Press [Off] to stop the motor before uploading data.
2. Press [Main Menu] to enter the parameter list.
3. Select *0-**Operation/Display*, press [OK].
4. Use the down arrow to scroll to *0-5* Copy/Save*, press [OK] to enter the submenu.
5. Press [OK] to enable editing of parameter *0-50 LCP Copy*.
6. Use the up or down arrows to scroll to *ALL to Copy*, press [OK] to select.
7. The progress bar will show the status of the process.
8. Press [Status] to return to the main status screen.
9. Press [Auto On] or [Hand On] to resume previous operating mode.

NOTE: Parameter data can be uploaded to the LCP through use of the Start-Up Genie. Simply select *Copy from LCP* from the setup selection menu at the beginning of the Genie. Select *All* to copy all parameters from the LCP including size dependent data. Select *Application Only* to copy all size independent data.

To download parameters to the controller from the LCP without use of the Start-Up Genie follow the procedure below.

1. Press [Off] to stop the motor before uploading data.
2. Press [Main Menu] to enter the parameter list.
3. Select 0-** *Operation/Display*, press [OK].
4. Use the down arrow to scroll to 0-5* *Copy/Save*, press [OK] to enter the submenu.
5. Press [OK] to enable editing of parameter 0-50 LCP Copy.
6. To copy all data from the LCP, including size dependent data, use the up or down arrows to scroll to *All from LCP*, press [OK] to select. To copy all size independent data, scroll to *Size indep. from LCP*, press [OK] to select.
7. The progress bar will show the status of the process.
8. Press [Status] to return to the main status screen.
9. Press [Auto On] or [Hand On] to resume previous operating mode.

Factory Reset

A factory reset can be performed to restore the controller back to default settings. There are multiple ways to perform this function.

Parameter 14-22 *Operation Mode* can be used to perform the factory reset function. Using this method does not change controller data such as operating hours, serial communication selections, fault log, alarm log, and other monitoring functions. To perform the reset through parameter 14-22 perform the following steps.

1. Press [Main Menu] to enter the parameter list.
2. Use the up and down arrows to scroll to 14-** *Special Functions*, press [OK].
3. Use the up and down arrows to scroll to 14-2* *Reset Functions*, press [OK].
4. Use the up and down arrows to scroll to 14-22 *Operation Mode*, press [OK].
5. Press [OK] to enable modification of the parameter.
6. Use the up and down arrows to scroll to *Initialization*, press [OK].
7. Remove input power from the unit and wait for the LCP to turn off.
8. Apply power to the unit. The reset is performed at power up.
9. *Alarm 80 Drive Initialized to Default Value* will be displayed.
10. Press [Reset] to return to operation mode.

Another way to perform the factory reset is to issue a 3 finger reset. The process is described below.

1. Remove power from the unit and wait for the LCP to turn off.
2. Press and hold [Status], [Main Menu], and [OK] at the same time. While holding down the buttons, apply power to the unit.

5.20 Final set-up and test

To test the set-up and ensure that the adjustable frequency drive is running, follow these steps.

Step 1. Locate the motor nameplate

- The motor is either star- (Y) or delta-connected (Δ). This information is located on the motor nameplate data.

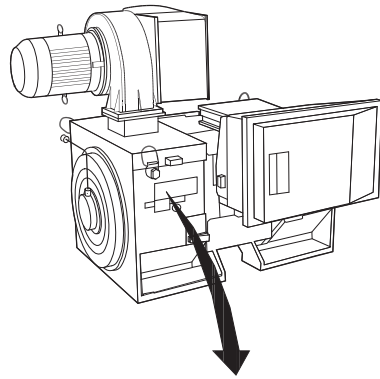

THREE PHASE INDUCTION MOTOR						
MOD MCV 315E	Nr.	135189 12 04			IL/IN 6.5	
kW 400	PRIMARY			SF 1.15		
HP 536	V 690	A 410.6	CONN Y	COSf 0.85	40	
mm 1481	V	A	CONN	AMB 40	°C	
Hz 50	V	A	CONN	ALT 1000	m	
DESIGN N	SECONDARY			RISE 80	°C	
DUTY S1	V	A	CONN	ENCLOSURE IP23		
INSUL I	EFFICIENCY %	95.8%	100%	95.8%	75%	WEIGHT 1.83 ton
⚠ CAUTION						

Figure 86: Test set-up

Step 2. Enter the motor nameplate data in this parameter list.

1.	Par. 1-20 Motor Power [kW] Par 1-21 Motor Power [HP]
2.	Par 1-22 Motor Voltage
3.	Par. 1-23 Motor Frequency
4.	Par. 1-24 Motor Current
5.	Par. 1-25 Motor Nominal Speed

To access this list, first press [QUICK MENU] key, then select "Q2 Quick Set-up".

Step 3. Activate the Automatic Motor Adaptation (AMA)

Performing an AMA will ensure optimum performance. The AMA measures the values from the motor model equivalent diagram.

1. Connect terminal 37 to terminal 12 (if terminal 37 is available).
2. Connect terminal 27 to terminal 12 or set par. 5-12 Terminal 27 Digital Input to 'No function' (par. 5-12 Terminal 27 Digital Input [0])
3. Activate the AMA par. 1-29 Automatic Motor Adaptation (AMA).
4. Choose between complete or reduced AMA. If a sine-wave filter is mounted, run only the reduced AMA, or remove the sine-wave filter during the AMA procedure.
5. Press the [OK] key. The display shows "Press [Hand on] to start".
6. Press the [Hand on] key. A progress bar indicates if the AMA is in progress.

Stop the AMA during operation

1. Press the [OFF] key - the adjustable frequency drive enters into alarm mode and the display shows that the AMA was terminated by the user.

Successful AMA

1. The display shows "Press [OK] to finish AMA".
2. Press the [OK] key to exit the AMA state.

Unsuccessful AMA

1. The adjustable frequency drive enters into alarm mode. A description of the alarm can be found in the Warnings and Alarms chapter.
2. "Report Value" in the [Alarm Log] shows the last measuring sequence carried out by the AMA before the adjustable frequency drive entered alarm mode. This number along with the description of the alarm will assist you in troubleshooting. If you contact Xylem for service, make sure to mention the number and alarm description.

NOTE: Unsuccessful AMA is often caused by incorrectly registered motor nameplate data or a too big difference between the motor power size and the adjustable frequency drive power size.

4. Set speed limit and ramp time

Table 20: Set up the desired limits for speed and ramp time

Par 3-02 <i>Minimum Reference</i>
Par 3-03 <i>Maximum Reference</i>
Par. 4-11 <i>Motor Speed Low Limit [RPM]</i> or par. 4-12 <i>Motor Speed Low Limit [Hz]</i>
Par. 4-13 <i>Motor Speed High Limit [RPM]</i> or par. 4-14 <i>Motor Speed High Limit [Hz]</i>
Par. 3-41 <i>Ramp 1 Ramp-up Time</i>
Par. 3-42 <i>Ramp 1 Ramp-down Time</i>

6 Operation

6.1 Pre-start procedure



Electrical Hazard:

If input and output connections have been connected improperly, there is potential for high voltage on these terminals. If power leads for multiple motors are improperly run in same conduit, there is potential for leakage current to charge capacitors within the frequency converter, even when disconnected from mains input. For initial start up, make no assumptions about power components. Follow pre-start procedures. Failure to follow pre-start procedures could result in personal injury or damage to equipment.

1. Make sure input power to unit is OFF and locked out. Do not rely on the frequency converter disconnect switches for input power isolation.
2. Verify that there is no voltage on input terminals L1 (91), L2 (92), and L3 (93), phase-to-phase and phase-to-ground.
3. Verify that there is no voltage on output terminals 96 (U), 97 (V), and 98 (W), phase-to-phase and phase-to-ground.
4. Confirm continuity of the motor by measuring ohm values on U-V (96-97), V-W (97-98), and W-U (98-96).
5. Check for proper grounding of the frequency converter as well as the motor.
6. Inspect the frequency converter for loose connections on terminals.
7. Record the following motor-nameplate data: power, voltage, frequency, full load current, and nominal speed. These values are needed to program motor nameplate data later.
8. Confirm that the supply voltage matches voltage of frequency converter and motor.

6.2 Pre-startup inspections

Item to Inspect	Description	Checked
Auxiliary equipment	<ul style="list-style-type: none"> • Look for auxiliary equipment, switches, disconnects, or input fuses/circuit breakers that may reside on input power side of the frequency converter or output side to motor. Ensure they are ready for full speed operation. • Check function and installation of any sensors used for feedback to the frequency converter. • Remove power factor correction caps on motor(s), if present. 	
Cable routing	<ul style="list-style-type: none"> • Ensure that input power, motor wiring and control wiring are separated or in three separate metallic conduits for high frequency noise isolation. 	
Control wiring	<ul style="list-style-type: none"> • Check for broken or damaged wires and connections. • Check that control wiring is isolated from power and motor wiring for noise immunity. • Check the voltage source of the signals, if necessary. • The use of shielded cable or twisted pair is recommended. Ensure that the shield is terminated correctly. 	
Cooling clearance	<ul style="list-style-type: none"> • Measure that top and bottom clearance is adequate to ensure proper air flow for cooling. 	
EMC considerations	<ul style="list-style-type: none"> • Check for proper installation with regard to electromagnetic capability. 	
Environmental conditions	<ul style="list-style-type: none"> • See equipment tech label for the maximum ambient operation temperature limits. • Humidity levels must be 5-95% non-condensing. 	
Fusing and circuit breakers	<ul style="list-style-type: none"> • Check for proper fusing or circuit breakers. • Check that all fuses are inserted firmly and in operational condition and that all circuit breakers are in the open position. 	

Item to Inspect	Description	Checked
Grounding (earthing)	<ul style="list-style-type: none"> The unit requires an earth wire (ground wire) from its chassis to the building ground (earth). Check for good earth connections (ground connections) that are tight and free of oxidation. grounding (earthing) to conduit or mounting the back panel to a metal surface is not a suitable ground (earth). 	
Input and output power wiring	<ul style="list-style-type: none"> Check for loose connections. Check that motor and mains are in separate conduit or separated screened cables. 	
Panel interior	<ul style="list-style-type: none"> Inspect that the unit interior is free of dirt, metal chips, moisture, and corrosion. 	
Switches	<ul style="list-style-type: none"> Ensure that all switch and disconnect settings are in the proper positions. 	
Vibration	<ul style="list-style-type: none"> Check that the unit is mounted solidly or that shock mounts are used, as necessary. Check for an unusual amount of vibration. 	

Checked by:

Date:

6.3 Apply power

NOTICE:

- **HIGH VOLTAGE.** Frequency converters contain high voltage when connected to AC mains. Installation, start-up and maintenance should be performed by qualified personnel only. Failure to comply could result in death or serious injury.
- **UNINTENDED START.** When the frequency converter is connected to AC mains, the motor may start at any time. The frequency converter, motor, and any driven equipment must be in operational readiness. Failure to comply could result in death, serious injury, equipment, or property damage.
- **POTENTIAL HAZARD IN THE EVENT OF INTERNAL FAILURE!** Risk of personal injury when the frequency converter is not properly closed. Before applying power, ensure all safety covers are in place and securely fastened.

1. Confirm that the input voltage is balanced with 3%. If not, correct voltage imbalance before proceeding. Repeat this procedure after the voltage correction.
2. Ensure that optional equipment wiring, if present, matches the installation application.
3. Ensure that all operator and start enable devices are in the OFF position. Panel doors should be closed or cover mounted.
4. Apply power to the unit. **DO NOT** start the frequency converter at this time. For units with a disconnect switch, turn to the ON position to apply power to the frequency converter.

6.4 Discharge time



WARNING:

Disconnect and lock out electrical power and wait for the minimum waiting time specified below. Failure to wait the specified time after power has been removed before performing service or repair could result in death or serious injury.

Frequency converters contain DC-link capacitors that can remain charged even when the frequency converter is not powered. To avoid electrical hazards, disconnect:

- AC mains
- Any permanent magnet type motors
- Any remote DC-link power supplies, including battery backups, ups and DC-link connections to other frequency converters.

Wait for the capacitors to discharge completely before performing any service or repair work. Refer to the following table for wait times:

Voltage (V)	Power range (HP)	Minimum waiting time (min)
380-480	150-350	20
380-480	450-600	40
525-690	150-400	20
525-690	450-600	30

High voltage may be present even when the warning LED indicator lights are off.

6.5 Frequency converter programming

6.5.1 Programming the controller

The controller can be programmed by using either the Start-Up Genie, Quick Menu mode or the Main Menu mode. The Main Menu mode allows access to all parameters. To modify a parameter or make a selection in either the Start-Up Genie, Quick Menu mode or the Main Menu mode follow the procedure below:

- To enter the Quick Menu mode press [Quick Menu] or to enter the Main Menu press [Main Menu].

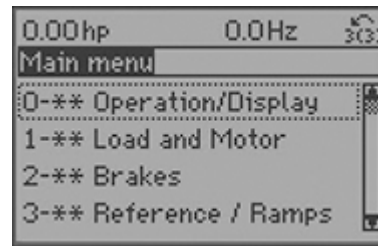

- The Start-Up Genie will begin automatically after the 1st power up or it can be rerun by selecting *Start-Up Genie* under *Quick Menus*.
- Select the desired selection in the Start-Up Genie, sub-menu in *Quick Menus* or parameter group in *Main Menu* by using the up and down arrows.
- Press [OK] to enter the sub-menu or selected parameter group.
- Once in the sub-menu or parameter group, use the up and down arrows to highlight the desired parameter. Press [OK] to select the parameter and enable editing.
- To edit the parameter use the up and down arrows to scroll through the parameter settings or selections. For numeric values with more than one digit, use the left and right keys to select the position within the number. The highlighted area can be modified by using the up and down arrows.
- Press [OK] to accept and save or [Cancel] to disregard the change.

Array parameters allow the modification of a group of parameters through one parameter address. An example of an array parameter is *5-40 Function Relay*. This parameter allows configuration of the 2 programmable relays included with the controller. To modify an array parameter follow the procedure below:

- Enter the Main Menu as previously described.
- Use the up and down arrows to scroll to *5-** Digital In/Out*. Press [OK] to enter the parameter group.
- Use the up and down arrows to scroll to *5-4* Relays*. Press [OK] to enter the parameter sub-group. The screen is shown below.

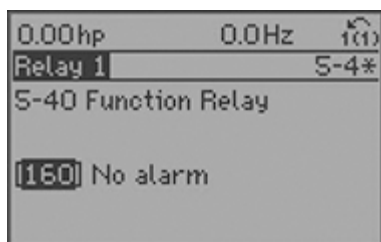
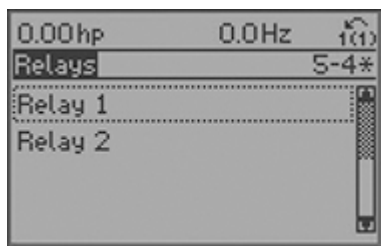

- To edit Relay 1, use the up and down arrows to highlight Relay 1 and press [OK] to select Relay 1.
- Press [OK] again to enable editing of Relay 1.
- Use the up and down arrows to select the desired relay function.
- Press [OK] to save the selection.
- Use the up and down arrows to select the 5-41 *On Delay, Relay* or 5-42 *Off Delay, Relay*. Repeat the steps above to edit these parameters.
- Press [BACK] to return to the Relays screen and repeat the above steps to edit the function for Relay 2.
- Press [Main Menu] to return to the Main Menu.

Quick menu

The Quick Menu mode contains various sub-menus that allow quick and easy access to common parameters. There are 6 sub-menus under Quick Menus. The 6 sub-menus are shown in the table below.

Table 21: Quick Menus

Sub-menu	Sub-menu Group Name	Description
Q1	My Personal Menu	Contains parameters commonly used to configure pump applications.
Q2	Quick Setup	Contains parameters commonly used to configure the controller.
Q3	Function Setups	Provides quick access to parameters commonly required for HVAC applications.
Q4	Start-Up Genie	Guides the user to configure the controller for various applications.
Q5	Changes Made	Shows the last 10 changed parameters, changes since factory defaults and input assignments.
Q6	Loggings	Displays graph line readouts of the LCP parameters. To change displayed LCP parameters use parameters 0-20 to 0-24.

My personal menu

My Personal Menu (Q1) has been configured at the factory to contain 20 parameters commonly used in pumping applications. Use My Personal Menu to change parameters while the system is running, such as changing Setpoint. The parameters found in My Personal Menu are shown below.

Parameter number	Parameter Name	Default Value	Parameter Description
20-21	Setpoint	50.0	Process setpoint. The controller will adjust speed to maintain this value. If multiple setpoints are enabled, this parameter will display and allow adjustment of the active setpoint.
22-44	Restart Difference (%)	10%	This is the difference between the setpoint and feedback that will cause the controller to restart from sleep mode. This is entered as a % of the setpoint. For a 50psi setpoint, a 10% Restart Difference will cause the controller to restart from sleep at 45psi.
4-12	Sleep Frequency/Low Limit[Hz]	30 Hz	This is the minimum speed of the motor and the speed at which the controller will enter sleep mode.
5-11	Terminal 19 Digital Input	No operation	This general purpose digital input is designated for the Pump Protect Function.
5-12	Terminal 27 Digital Input	No operation	This general purpose digital input is designated for the Pump Protect Function.
22-00	Pump Protect Delay	10 s	This is the time delay between detection of a Pump Protect condition and the triggering of the Pump Protect Alarm.
22-26	No Water/Loss of Prime Function	Man. Reset Alarm	This configures the No Water/Loss of Prime Function. Set this value to Man. Reset Alarm in order to utilize the No Water/Loss of Prime Restart Function.
22-39	No Water/Loss of Prime Limit	Size Dependent (HP)	This value sets the No Water/Loss of Prime limit. When the pump HP falls below this value while operating at maximum speed, the No Water/Loss of Prime Function will be implemented after the time specified in No Water/Loss of Prime Protection Delay [22-27].

Parameter number	Parameter Name	Default Value	Parameter Description
22-50	Under Pressure Function	Off	This parameter configures the Under Pressure Function. The Under Pressure Alarm/Warning is issued when the system pressure falls below the Under Pressure Limit [22-52] for longer than the Under Pressure Time Delay [22-51].
22-51	Under Pressure Delay Time	30 s	This parameter specifies the time between detection of an Under Pressure event and when the action defined in Under Pressure Function is issued.
22-52	Under Pressure Difference	10%	Under Pressure Difference is the difference between the setpoint and the actual pressure that will trigger the Under Pressure Function. This value is set as a % of Maximum Reference/Feedb. [20-14]
5-40	Function Relay	Relay 1: No Alarm Relay 2: Running	This parameter configures Relay 1 and 2 functions. This array parameter allows configuration of both relays. See Programming the controller for details on how to navigate the array parameter screen . [0] = Relay 1, [1] = Relay 2
5-41	On Delay, Relay	Relay 1: 0.01s Relay 2: 0.01s	This parameter configures Relay 1 and 2 On Delay Time. This array parameter allows configuration of both relays. See Programming the controller for details on how to navigate the array parameter screen . [0] = Relay 1, [1] = Relay 2
20-00	Feedback 1 Source	Analog Input 53	Feedback source for the PID controller, transducer input source.
20-13	Min Reference/Feedb.	0.0	Minimum feedback value for the transducer.
20-14	Max Reference/Feedb.	300.0	Maximum feedback value for the transducer.
3-41	Ramp 1 Ramp Up Time	10 s	Ramp up time (0 to full speed). Increasing this time will produce a slower ramp up.
3-42	Ramp 1 Ramp Down Time	5 s	Ramp down time (full speed to 0). Increasing this time will produce a slower ramp down.

Parameter number	Parameter Name	Default Value	Parameter Description
20-93	PID Prop Gain	5	Proportional correction gain for PID controller. Increasing this value will produce a faster system response. CAUTION: Increasing this value too high can make the system unstable and produce severe oscillations.
20-94	PID Integration Time	3.3 s	Integration time for the PID controller. Increasing this value will produce a slower system response. CAUTION: Decreasing this value too low can make the system unstable and produce severe oscillations.

Start-Up Genie

This controller is equipped with a Start-Up Genie which allows the user to easily configure the controller for various pump control applications. The Genie configures parameters that are based on the selections that are made by the user. The Genie allows the user to configure the motor, application type, inputs, outputs, pump protection features, flow compensation, and communications. The application types include single pump, constant slave, duplex control, speed control, and test run mode. See the Setup and Commissioning section for details.

Main menu

The parameters in the Main Menu are grouped by category. Note that some groups are not visible unless the appropriate option card is installed. The parameter groups in the Main Menu are shown below.

Parameter Group	Parameter Group Name
0	Operation/Display
1	Load and Motor
2	Brakes
3	Reference/Ramps
4	Limits/Warnings
5	Digital In/Out
6	Analog In/Out
8	Comm. and Options
9	Profibus*
10	CAN Fieldbus*
11	LonWorks*
13	Smart Logic
14	Special Functions
15	Drive Information
16	Data Readouts
18	Info & Readouts
20	Drive Closed Loop
21	Ext. Closed Loop
22	Appl. Functions

Parameter Group	Parameter Group Name
23	Time-based Functions
24	Appl. Functions 2
25	Cascade Controller
26	Analog I/O Option

* Appropriate option card must be installed.

Refer to the appendix for a complete parameter list.

6.5.2 Setup and commissioning

Start-Up Genie



CAUTION:

When a Start (Closed) signal is present on DI18, the controller can start the pump/motor at any time without warning. Set DI18 to Stop (Open) or press the [Off] operation key before using the Genie. Apply the Start signal to the controller only when pump/motor operation is desired.

The Start-Up Genie provides a fast and easy method for configuring the controller for various pump applications. The Navigation keys are used to make selections within the Genie. The [Info] button can be pressed at any time while in the Genie to retrieve additional information about the current screen or parameter.

To navigate through the Start-Up Genie, press [OK] to enable editing of a screen or parameter. Use the up and down arrows to highlight the desired selection then press [OK] to confirm the selection. Next use the down arrow to save the parameter and navigate to the next screen. The up arrow transitions to the previous screen. If the screen shows the desired setting is already selected for a particular parameter or function, simply use the down arrow to proceed to the next screen.

NOTE: Be sure to press the down arrow to save the parameter after confirming the selection. This ensures all associated parameter settings and background calculations are performed and saved properly. After pressing the down arrow to save the parameter the Genie may be slow to respond as these settings and calculations are performed.

Press [Cancel] to exit parameter editing without saving or to change a saved parameter or selection back to the previously saved while still in the current screen. Pressing [Back] will also exit parameter editing without saving. To exit the Start-Up Genie at any time, first exit parameter editing then press [Back] then [OK].

The arrows shown in the lower right hand corner of the LCP indicate the options for navigation. When an up arrow is displayed, pressing the up arrow will transition to the previous screen. When a down arrow is displayed, pressing the down arrow will transition to the next screen. When both an up and down arrow are displayed then pressing the up arrow will transition to the previous screen and pressing the down arrow will transition to the next screen.

NOTE: Ensure the controller is set to Stop (DI 18 Open) and is set to Setup 1 prior to running the Start-Up Genie. To place the controller in Setup 1, ensure DI 33 is Open and the controller is set to Lead for Duplex systems. To manually change the lead pump in a Duplex System press [OK] and the right arrow keys on the lead drive. In Duplex Systems ensure alternation does not occur while running the Start-Up Genie by pressing [Off] before entering the Start-Up Genie.

The Genie starts automatically the first time the controller has been powered in the field or if the Genie has not been used previously. The Genie can be started at any time by accessing the *Quick Menus* screen by pressing [Quick Menu] then using the up and down arrows to highlight *Q4 Start-Up Genie*. Press [OK] to enter the Genie.



There are various screen types in the Start-Up Genie. One of these is the dual parameter screen.

To navigate the dual parameter screen use the up and down arrows to highlight the desired parameter. Press [OK] to enable editing of the highlighted parameter. Use the up and down arrows to set the parameter to the desired setting. Press [OK] to confirm the selection. To modify the other parameter shown, use the up and down arrows to highlight the other parameter and repeat the steps used to set and confirm the setting the previous parameter.

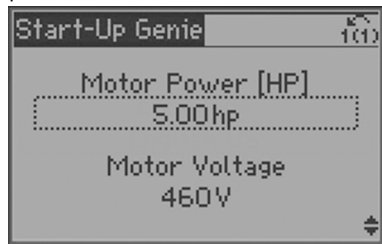

The array parameter screen allows configuration of a group of parameters configured as an array. For example the Relay Function screen shown below is an array parameter screen.

To navigate the array parameter screen press [OK] to enable editing of the array index. The array index is shown on the left side of the parameter value. Use the up and down arrows to select the desired index. Press [OK] to set the array index and enable editing of the parameter at the selected index. Use the up and down arrows to set the parameter to the desired setting. Press [OK] to confirm the selection.



Within the Start-Up Genie some screens will display "[unit]" after a parameter value. This nomenclature is used when a parameter is entered in the control units selected in the Start-Up Genie. For example, when entering the Setpoint for closed loop pressure control, the value could be entered in psi, bar, in HG, etc. In this case "[unit]" is used to account for this variation in units.

The first menu requires the user to set the language. To select a language, press [OK] to enable parameter editing. Use the up and down arrows to highlight the language then press [OK] to save the selection.



Next use the down arrow to proceed to the next section.

If this is the first time the Genie has run, the Genie will guide the user through the setup of the motor parameters. If the Genie has run previously, the user can choose the desired *Setup Selection* to configure a specific function in the controller. Use the up and down arrows to highlight the desired setup and press [OK] to enter the setup. The choices for the *Setup Selection* menu are described in the table below.



Table 22: Setups with the Genie

Setup	Description
Motor	This setup allows configuration of the motor parameters. These settings are found on the motor nameplate.
Application	The Application setup allows the user to configure the motor type, operating mode, units and ramps.
Feedback	This setup allows configuration of up to 3 feedback sources. The feedbacks can be taken in to the controller through analog inputs or communications.
Setpoint	This setup allows configuration of up to 2 setpoints. If multiple setpoints are used, the setpoint is selected by using DI 33.
Constant Slave	This setup configures the controller to operate up to 2 external fixed speed pumps using the 2 on board relays.
Flow Compensation	This setup configures the Flow Compensation function which can automatically adjust the system setpoint to offset the affect of friction loss in the system.
Pump Protection	This setup configures Sleep Mode, Flow Check, No Water/Loss of Prime and Pump Protect functions.
Digital Input	This setup allows configuration of the digital inputs.
Relay and Analog Output	This setup allows configuration of the relay and analog outputs.
Communication	This setup configures the on board fieldbus communications.
Copy to LCP	This setup allows all the controller parameters to be copied to the LCP. This is helpful for saving the drive state or to quickly configure another controller with the same settings.
Copy from LCP	This setup allows all the controller parameters to be copied from the LCP. This is helpful for reverting the drive to a previous state or to quickly configure another controller with the same settings.

Motor setup

The motor data required to complete the Motor Setup can be found on the motor nameplate. The Start-Up Genie will prompt the user for Motor Power (HP), Motor Nominal Voltage, Motor Nominal Frequency (Hz), Motor Nominal Speed (RPM), Motor Current (FLA), Current Limit (%) and Motor Type. Set the Current Limit as a percentage of the Motor Current (FLA). For example, if the Motor Current (FLA) indicated on the motor nameplate is 10A and the Motor Service Factor Current (SFA) is 11.5A, enter 115% for

Current Limit (%). Be sure to properly set the Motor Current (FLA) and Current Limit. These parameters will configure the motor overload protection feature.

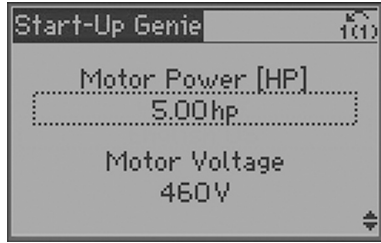

The Motor Type menu allows selection of either a Submersible or Surface motor. This selection will configure specific settings to properly operate the chosen motor type.



- If a Submersible motor is selected, the controller is configured to have a 30Hz minimum speed (parameter Sleep Frequency/Low Limit [4-12] = 30Hz), ramp from stop to 30Hz in 1 second (parameters 1-78 = 29Hz and 3-82 = 1 s) and to coast to stop (parameters 1-80 = Coast, 1-82 = 10Hz).
- If a Surface motor is selected, set the minimum speed (default parameter Sleep Frequency/Low Limit [4-12] = 30Hz), the stop ramp will be controlled by the default deceleration ramps (parameters 3-42 and 3-52) and to coast to stop (parameters 1-80 = Coast, 1-82 = 10Hz).

NOTE: There are various parameters that are linked to the motor parameter settings. Changing the motor parameter settings will also change the settings of these linked parameters. It is recommended to set the motor parameters first to avoid overwriting any settings made in the Start-Up Genie.

Application setup

The next menu set is the Application Setup which will allow selection and configuration of the application type and control response. Select the application type by first selecting the Operating Mode. Selecting the Operating Mode will configure specific parameters to configure the selected mode. If the Operating Mode is changed, any changes made to configure the previously configured Operating Mode will be overwritten. The Operating Mode can be set to Single Pump, Constant Slave, Duplex Control, Speed Control or Test Run Mode. The various Operating Modes are defined below.

Table 23: Operating modes

Operating Mode	Description
Single Pump	This mode is the default Operating Mode. Use this mode for constant pressure, flow or level applications that use 1 controller operating a single pump.
Constant Slave	This mode allows control of up to 2 external fixed speed pumps using the 2 on board relays. This mode can be used to extend the capacity of a system by staging fixed speed pumps as the demand in the system increases. Pumps can then be destaged as the system demand decreases.

Operating Mode	Description
Duplex Control	This mode configures the controller as part of a 2 controller, 2 pump system. Both pumps will run at the same varying speed. The staging and destaging of pumps can be configured to create a lead/lag system. The lead pump can be alternated based on elapsed time.
Speed Control	This mode configures the controller to accept a speed command through an analog input, pulse input or extended PI loop [21-**]. A start signal on DI 18 [5-10] is required.
Test Run Mode	Test Run Mode allows the controller to be configured to run the pump at specified speed for a specified amount of time. The action will be started by a digital input (DI 19).

Single pump

The Single Pump Operating Mode is the default operating mode for the controller. Use this mode for constant pressure, flow or level applications that use 1 controller operating a single pump.

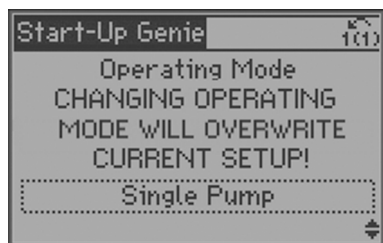

- The Application Type allows selection of the type of control. Select either Constant Pressure, Flow Control or Level Control.
- Next select the appropriate units for the application. These units will be displayed on the LCP default status screen.

If Level Control is the Application Type, select whether the application is a Tank Fill or Tank Empty application.



- In a 'Fill' application the pump will speed up when the level in the tank drops below the setpoint level.
- In an 'Empty' application the pump will speed up when the level in the tank is above setpoint level.
- The *PID Normal/Inverse Control* [20-81] parameter is set to *Inverse* for the 'Empty' application and to *Normal* for the 'Fill' application.

The ramp times are selected next. Select from either a Fast, Medium or Slow ramp.



- A Fast ramp setting will have a 5 second acceleration ramp time and an 8 second deceleration time.
- A Medium ramp setting will have a 10 second acceleration ramp time and a 10 second deceleration time.
- A Slow ramp setting will have a 20 second acceleration ramp time and a 15 second deceleration time.
- Acceleration ramps are set in Parameters [3-41] and [3-51]. Deceleration ramps are set in Parameters [3-42] and [3-52].

The next screen will allow the user to automatically configure the rest of the parameters to default settings. The only parameter that must be set after selecting [Yes] is the setpoint. After the setpoint is configured the setup of the controller is complete. The default configurations are described in the table below. Note that [unit] will reflect the control units selected previously. If No is selected the Genie will prompt to proceed to the Feedback Setup.

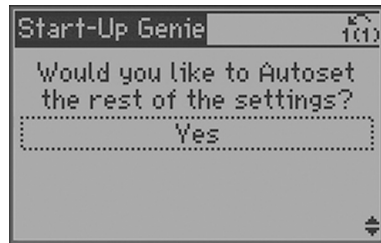
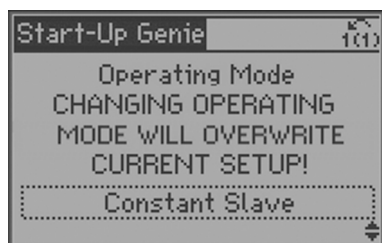

Table 24: Autoset configuration

Autoset Configuration	Constant Pressure	Level Control	Flow Control
Transducer Max Feedback	300 [unit]	300 [unit]	300 [unit]
Transducer Type	4-20mA	4-20mA	4-20mA
Feedback 1 Source	AI 53	AI 53	AI 53
PID Performance	Normal	Fill (Normal)	Normal
Sleep Mode	Enabled	Enabled	Disabled
Sleep Frequency	30 Hz	30 Hz	NA
Restart Difference	5 [unit]	5 [unit]	NA
No Water/Loss of Prime Fault	Enabled	Enabled	Enabled
No Water/Loss of Prime Restart Time	10 min.	10 min.	10 min.

Constant slave

The Constant Slave Operating Mode allows control of up to 2 external fixed speed pumps using the 2 on board relays. This mode can be used to extend the capacity of a system by staging fixed speed pumps as the demand in the system increases. Pumps can then be destaged as the system demand decreases. The variable speed pump is always the lead pump. The fixed speed pumps can be staged and destaged to create a lead/lag system.



The Application Type can be set to either Constant Pressure or Level Control. Set control variable units and ramps as described in Single Pump Operating Mode.

The next menu prompts the user to set the number of pumps in the system. Enter the number of pumps in the system, including the variable speed pump. The selection will be entered in to parameter [25-06] *Number of pumps*. If 2 pumps are selected, this means that there is 1 variable speed pump and 1 fixed speed pump in the system. The fixed speed pump will be controlled by relay 1.

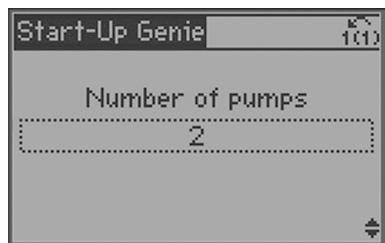

The next menu prompts the user to enable or disable *Run Time Equalization* [25-04]. When the parameter is disabled the pumps will always be turned on (stage) in the order of pump 1 then pump 2 and turned off (destage) in the order of pump 2 then pump 1. Enabling this parameter will stage and destage the fixed speed pumps to provide equal run time for each fixed speed pump.



The next menu configures the [25-20] *Staging Bandwidth*. The Staging Bandwidth (SBW) sets a range around the setpoint in which no staging or destaging of pumps will occur. This range is set to avoid frequent staging and destaging of pumps and to accommodate normal fluctuations present in the system. The Staging Bandwidth (SBW) is set as a percentage of the setpoint. For example if a setpoint of 50 psi is selected, and the SBW is set to 10% then no staging or destaging of pumps will occur in the range of 45-55 psi.



The next menu configures the staging delay times. These delay times define the length of time that the system pressure must be outside the SBW before staging or destaging pumps will occur. For example if the [25-23] *SBW Staging Delay* is set to 10 seconds and the system pressure is outside the SBW for more than 10 seconds a fixed pump will be staged. If the pressure transitions back inside the SBW before the delay time expires, the timer will reset. Parameter [25-24] *SBW Destaging Delay* sets the delay time associated with pumps being destaged.

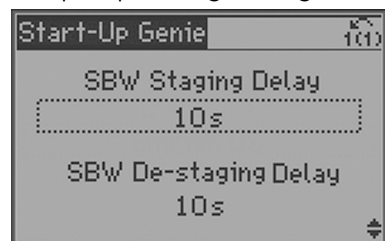

Duplex control

The Duplex Control Mode configures the controller for operation in a system with 2 controllers and 2 variable speed pumps. Each controller is connected to a single pump. When configured as a lead/lag system (Duty Standby Disabled) the pumps can be staged or destaged as the demand requires. When both pumps run at the same time they will operate at the same speed. The lead controller/pump can be switched/alternated between the 2 controllers.

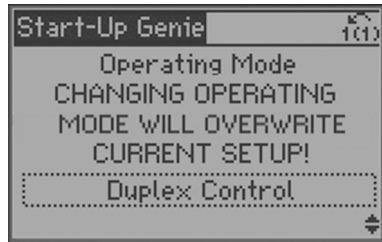

NOTE: The Duplex Control Mode requires specific control wiring for proper operation. Consult the Wiring to Control Terminals section in this manual for details.

NOTE: The Duplex Control Mode requires specific parameter settings to proper operation. Changing to Duplex Control will overwrite any preconfigured parameters.

As in the previously described application types, the control units and ramp times are configured first. The next screen allows the user to automatically configure the rest of the parameters to default settings. The only parameter that must be set after selecting Yes is the setpoint. After the setpoint is configured the setup of the controller is complete. The default configurations are described in the table below.

Table 25: Duplex Autoset Configuration

Duplex Autoset Configuration	
Transducer Max. Feedback	300 [unit]
Transducer Type	4-20mA
Feedback 1 Source	AI 53
Sleep Frequency	30 Hz
Restart Difference	5 [unit]
No Water/Loss of Prime Fault	Enabled
Duty Standby	Disabled
Lag Start Freq	59 Hz
Lag Stop Freq	35 Hz
Alternation	Enabled
Alternate Time	24 Hrs
Pump Exercise Time	0 s (Disabled)

Duty standby

Enabling Duty Standby allows the system to be configured as a 2 pump redundant system. With Duty Standby enabled both pumps will not run at the same time during normal operation. Only the lead pump will run when required.

The pumps can be configured to alternate the lead pump by enabling Alternation. Disabling Duty Standby configures the 2 pump system as a lead/lag system. With Duty Standby disabled, the pumps can be staged/destaged as required based on system demand.

NOTE: If *Duty Standby* is enabled, both pumps may run at the same time during alternation, after a start command is received or after an alarm is reset depending on the setting of *Start Delay [1-71]*. Set the *Start Delay [1-71]* longer than the *Ramp Down Time [3-42]* of the other pump or 3 seconds, whichever is longer, to avoid this condition. Refer

to *Pump Exercise* for details on how Duty Standby, Pump Exercise and Start Delay impact when pumps are expected to run.



Lag pump start frequency and lag pump stop frequency

The *Lag Pump Start Frequency* and *Lag Pump Stop Frequency* can be configured to control the frequency/speed that the lag pump is staged and destaged. This feature is enabled only when Duty Standby is Disabled. The *Lag Pump Start Frequency* (staging frequency) should be set to a frequency close to the maximum speed of the motor/pump. The default is set to 59Hz with a maximum speed of 60Hz. This will ensure best utilization of each pump. The *Lag Pump Stop Frequency* (destaging frequency) should be set to a frequency above the [4-12] *Sleep Frequency/Low Limit [Hz]* of the lead pump. For example, when the [4-12] *Sleep Frequency/Low Limit [Hz]* is set to 30Hz, the Lag Pump Stop Frequency should be set to 35Hz. The actual value used depends on system requirements.

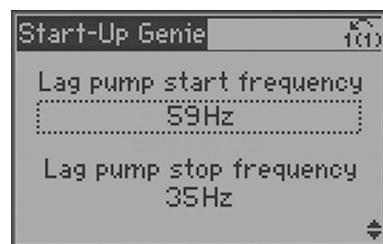

Alternation and alternation time

Enabling *Alternation* allows the lag pump to become the lead after the *Alternation Time* expires. Enabling *Alternation* allows equalization of loading between the 2 pumps and controllers. The *Alternation Time* is based on elapsed time, not pump run time. Because of this it is recommended to set *Alternation Time* to a time that is greater than or equal to 24 hours. For example, in a system that has high demand in the morning, setting the Alternation Time to 24 hours ensures each pump will be the lead pump every other morning which will equalize the loading between the two pumps.



Note: The lead pump can be manually alternated by pressing the [OK] and right arrow keys on the lead drive.

Pump exercise

The Pump Exercise Function forces the lead pump to run for a specified time during lead/lag pump alternation. This function is designed to help prevent the effects that can occur on a pump as a result of remaining idle for long periods of time. Set the Pump Exercise Time to the amount of time the new lead pump will run during alternation. For example, if the Pump Exercise Time is set to 10 seconds, the new lead pump will run for 10 seconds when the lead and lag pumps alternate. Set Pump Exercise Time to 0s to disable the function.

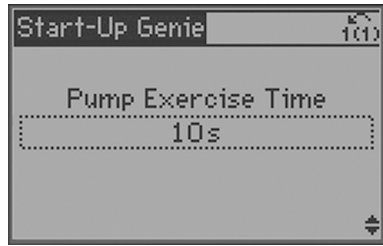

NOTE: If Pump Exercise is enabled, the pump will run after alternation of the lead pump even if there is no demand in the system.

NOTE: If Duty Standby is enabled, Pump Exercise cannot be disabled. Refer to the table below for details.

The settings for Duty Standby, Pump Exercise and Start Delay can impact when a pump is expected to start. The table below shows how these settings impact when a pump will start.

Duty Standby	Pump Exercise	Explanation
Disabled	Disabled	If both controls are given a start command at the same time or both controls are reset from a fault at the same time, both pumps will run until the lead pump and lag pump roles are established. With both functions disabled, the duplex system will operate as a lead/lag system. On Alternation, the new lead pump will not run unless there is demand in the system.
Disabled	Enabled	<p>The lag pump will start when the lead pump wakes up from sleep or if the lead pump is stopped and is then given a start command. For these conditions the lag pump will run for the time specified in <i>Pump Exercise Time</i> [22-40]. The lag will continue to run if the speed command from the lead pump is greater than the <i>Lag Pump Stop Frequency</i> [4-12].</p> <p>On Alternation, the new lead pump will run for the time specified in Pump Exercise Time. After the Pump Exercise Time, the pump will continue to run if demand is present or will go to sleep if there is no demand.</p>
Enabled	Enabled	<p>On Alternation and no demand, the new lead pump will start and run for the time specified by <i>Pump Exercise Time</i> [22-40] or <i>Sleep Delay</i> [22-24], whichever is longer. The pump will then go to sleep, if enabled.</p> <p>On Alternation with demand, the new lead pump will ramp up while the previous lead pump is ramping down. In order to ensure both pumps do not run at the same time in this condition, set the <i>Start Delay</i> [1-71] time longer than the <i>Ramp Down Time</i> [3-42].</p>

Start delay

The Start Delay Function delays the lead pump from starting for the time specified. This function can be used to prevent rapid cycling of the system or to prevent the new lead pump from starting up while the lag pump is ramping down during alternation. For example, if the Start Delay Time is set to 10 seconds and the pump is given a start command, the pump will start 10 seconds after the command to start is received by the controller. In a Duplex System with the Start Delay set to 10 seconds, if Alternation is enabled and the Alternation Time expires the new lead pump will start after a 10 second delay. If Duty Standby is enabled, set the Start Delay longer than the *Ramp Down Time* [3-42] of the other pump to ensure both pumps do not run at the same time.



Speed control

Speed Control Mode allows the speed to be controlled by an external device such as a PLC or BMS. A start signal on DI 18 is required to start and stop the pump.

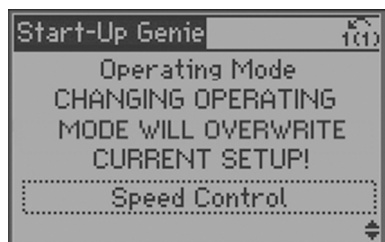

To configure Speed Control Mode first select the speed reference source. Select the speed reference source as either an analog input or, if using the fieldbus as the speed reference source, select No Function. When using the analog inputs be sure to set the analog input configuration switches to the appropriate feedback type. Refer to the Analog Input Configuration (Switches A53 and A54) section for details on setting the analog input configuration switches. Refer to the Common Terminal Wiring Configurations section in this manual for detail on wiring external devices to the analog inputs.

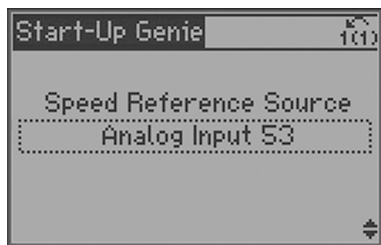

Next set the minimum and maximum reference/feedback values. The *Low Ref./Feedb. Value* is the speed value that corresponds with the low current (0 or 4mA for current references) or low voltage (0V for voltage references) that will be applied to the analog input. The *High Ref./Feedb. Value* is the speed value that corresponds with the high current (20mA for current references) or high voltage (10V for voltage references) that will be applied to the analog input. For example, if the application uses a 4-20mA reference signal on AI 53 and the pump is required to operate from 30Hz to 60Hz, set [6-14] Terminal 53 Low Ref./Feedb. Value to 30 and [6-15] Terminal 53 High Ref./Feedb. Value to 60.

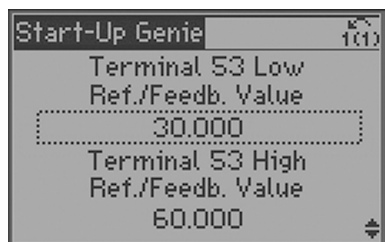

The minimum and maximum speed reference values are set next. These values are the minimum and maximum speed settings for the application. These settings will limit the controllable speed range of the pump. The speed range will be limited to the *Minimum Speed Reference* as the low speed limit and *Maximum Speed Reference* as the high speed

limit. Using the example above, set the *Minimum Speed Reference* to 30Hz and the *Maximum Speed Reference* to 60Hz.

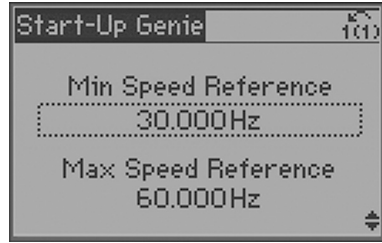

Test run mode

Test Run Mode allows the controller to perform a test which will ramp the pump at a specified speed in order to perform a test on the system and pump/motor. Test Run Mode is triggered to start based on the state of DI 18. When DI 18 is closed, the test will begin. When DI 18 is open, test run mode will stop. To configure Test Run Mode set the test run speed and test run ramp time. The Test Run Speed is the speed that the controller will ramp the pump to. The Test Run Ramp Time is the ramp used to reach the Test Run Speed. This ramp is the time to ramp from stop (0 RPM) and the rated motor speed. The Test Run Ramp Time applies to both acceleration and deceleration in Test Run Mode.



Feedback setup

The controller can utilize up to 3 feedback sources using the onboard IO. 2 of these sources can be configured for the analog inputs (AI 53 and AI 54). The third can be set to bus feedback which can be set through the onboard fieldbus communications.

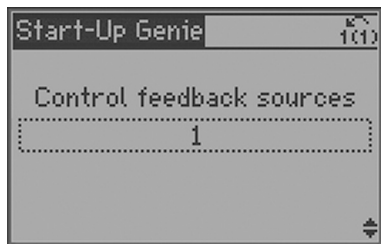

When using analog inputs be sure to set the analog input configuration switches to the appropriate feedback type. Refer to the Analog Input Configuration (Switches A53 and A54) section for details on setting the analog input configuration switches. Refer to the Common Terminal Wiring Configurations section in this manual for detail on wiring external devices to the analog inputs.

If multiple feedback sources are selected then the *Feedback Function [20-20]* can be configured. The Feedback Function determines how the multiple feedbacks will be used to control the system.



Feedback function [20-20]	
Sum	The sum of all feedbacks will be in the feedback to the controller.
Difference	The difference between Feedback 1 and Feedback 2 will be the feedback to the controller. This setting is commonly used to configure a differential pressure signal using 2 separate transducers. NOTE This selection is only valid with Feedback 1 and Feedback 2. Feedback 3 is not used with this selection.
Average	The average of all feedback will be the feedback to the controller.
Minimum	The lowest feedback will be the feedback to the controller.
Maximum	The highest feedback will be the feedback to the controller.

The minimum and maximum values for each feedback source must be configured to properly scale the input. For example, for a 0-300 psi transducer, set the Low Feedback Value to 0 psi and the High Feedback Value to 300 psi.

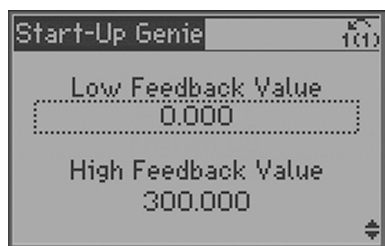

A Sensor Fault can be enabled or disabled for each feedback. If the Sensor Fault is enabled and the input to the feedback source falls below 2mA for 4-20mA signals, the Sensor Fault is issued. The Sensor Fault will automatically restart according to [14-20] *Reset Mode* and [14-21] *Automatic Restart Time*. The defaults for these parameters are set for an Automatic reset x 3 and an Automatic Restart Time of 10 seconds. For example, with the default settings if a Sensor Fault is issued the controller will attempt to reset every 10 seconds. The controller will make 3 attempts to reset the fault. If the fault is not cleared in this time the controller will require a manual reset.

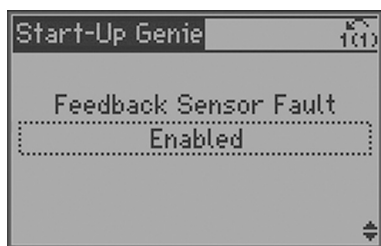

Setpoint setup

The controller can be configured to switch between 2 different setpoints. The setpoints will be selected through digital input 33 (DI 33, parameter 5-15). When parameter 5-15 is set to *Set-up Select Bit 0* and DI 33 is open, the controller will use SP1 (*Setpoint 1 [20-21] Setup 1*) as the target pressure, flow or level for the system. When parameter 5-15 is set to *Set-up Select Bit 0* and DI 33 is closed (connected to 24V), the controller will use SP2 (*Setpoint 1 [20-21] Setup 2*) as the target pressure, flow or level for the system.

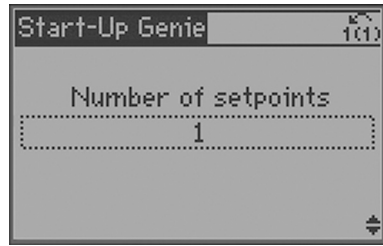

Flow compensation setup

As flow in a pumping system increases, the system friction head losses also increase. Friction head loss is higher in systems with increased pipe lengths or decreased pipe size. The impact of this head loss is that the pressure at different points in the system will vary depending on flow rate and the distance from the pump. The loss will be most significant in the zones farthest from the pump. The controller's internal Flow Compensation function is used to correct the effect of friction head loss in the system. The flow compensation function calculates a control curve based on pump and system parameters. The controller actively adjusts the setpoint along the control curve based on the speed of the pump. Since a change in speed is proportional to a change in flow, the controller effectively adjusts the setpoint based on a change in speed. A change in pressure varies with the square of the change in speed or flow so a quadratic (square) compensation factor is used to adjust the setpoint. Parameter [22-81] *Square-linear Curve Approximation* can be modified to adjust the control curve between a linear (0%) and quadratic (100%). Note that 100% quadratic is the ideal compensation curve. The diagram below illustrates this concept. The rating curve is the pump performance curve at rated speed. The design curve is the system curve at design speed.

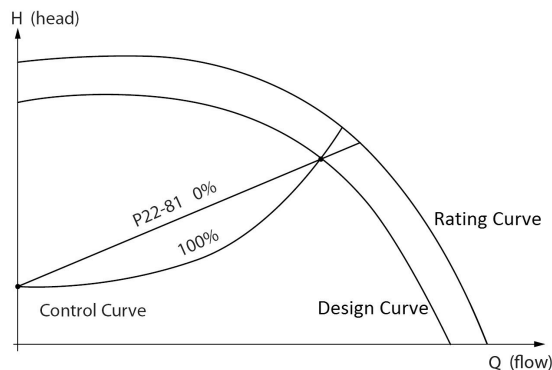

Figure 87: Flow compensation control curve

The flow compensation function requires some system parameters to be set in the controller to accurately model the control curve. Parameters must be set based on the design of the system in order to properly configure this function. The parameters that are required to be configured will depend on whether the speed at the design point is known. If the speed at the design point is known, set [22-82] *Work Point Calculation* to disabled. Set the [22-84] *Speed at No Flow [Hz]* and [22-87] *Pressure at No-Flow Speed*, which correlate to point A on the diagram below. The intersection of the system [20-21] *Setpoint* and [22-86] *Speed at Design Point [Hz]* correlates with point B. With this information the controller can then calculate the control curve. Refer to the diagram below.

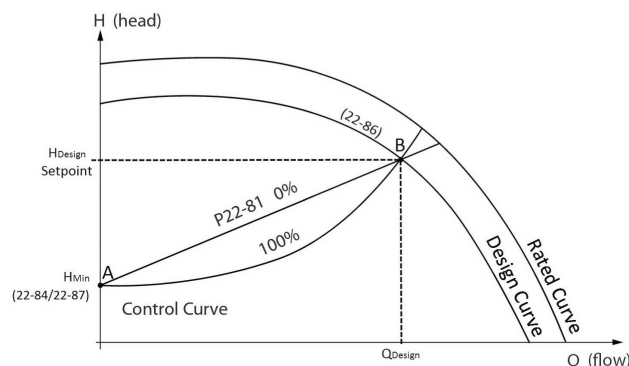

Figure 88: Flow compensation when speed at system design working point is known

Table 26: Flow compensation parameters when speed at design point is known

Parameter Number	Description	Set to
22-80	Flow Compensation	Enabled
22-81	Square-Linear Curve Approximation	Modify between 100% (square) and 0% (linear) per system requirements.
22-82	Work Point Calculation	Disabled – speed at the design point is known
22-84	Speed at No Flow [Hz]	To find this point, close all of the discharge valves in the system and briefly run the pump at the minimum design head. The speed corresponding to the minimum head requirement at no flow will be entered here.
22-86	Speed at Design Point [Hz]	These setpoints correspond to the speed required to maintain point B (design head {[20-21] Setpoint} and design flow)
22-87	Pressure at No Flow	System pressure at no flow and no flow speed. This is the minimum design head.

If the speed at the design point is unknown, the [22-82] *Work Point Calculation* must be enabled. With the [22-82] *Work Point Calculation* enabled the controller will calculate the speed at the design point based on settings of some additional parameters correlating to the points shown on the diagram below. The first point determined is point A which is the minimum required head at minimum speed ([22-84] *Speed at No Flow [Hz]* and [22-87] *Pressure at No-Flow Speed*). Points C and D can be determined by consulting the pump performance curve. Point C is determined by extending the design [20-21] *Setpoint* line horizontally to intersect the rated curve which is the pump performance curve at rated speed (usually 50 or 60Hz). The flow at this point (Q_{Rated}) is set in [22-90] *Flow at Rated Speed*. Point D is determined by extending the design flow point (Q_{Design}) vertically to intersect the rated speed curve. The head generated at this flow and speed is set at [22-88] *Pressure at Rated Speed*. Knowing points A, C and D allow the controller to calculate point E along with the control curve which includes point B (speed, pressure and flow at design speed). Refer to the diagram below.

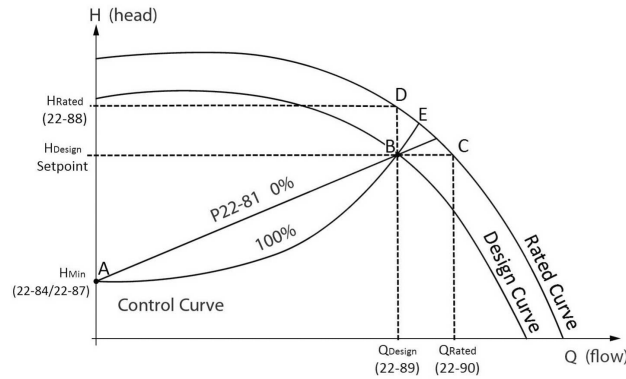

Figure 89: Flow compensation when speed at design working point is unknown

Table 27: Flow compensation parameters when speed at design point is unknown

Parameter Number	Description	Set to
22-80	Flow Compensation	Enabled
22-81	Square-Linear Curve Approximation	Modify between 100% (square) and 0% (linear) per system requirements.
22-82	Work Point Calculation	Enabled – speed at design point is unknown
22-84	Speed at No Flow [Hz]	To find this point, close all valves in the system and run the pump at the minimum head. The speed corresponding to the minimum head requirement at no flow will be entered here. Point A.
22-87	Pressure at No Flow	System pressure at no flow and no flow speed. This is the minimum design head. Point A.
22-88	Pressure at Rated Speed	This setting corresponds to the head developed at design flow and rated speed. This value can be defined using the pump performance curve. Intersects with the design flow to form point D.
22-89	Flow at Design Point	This setting corresponds to the system design flow. Intersects with the pressure at rated speed to form point D and with the setpoint to form point B.
22-90	Flow at Rated Speed	This setting corresponds to the flow at rated speed. This value can be defined using the pump performance curve. Intersects with the setpoint to form point C.

Dual pump value increase

In a Duplex Control System the friction losses can increase when both the lead and lag pumps are running due to the additional flow in the system. When both pumps are running, the Rated Curve and Design Curve shown above will change (reach higher flows at a given pressure) when compared to when a single pump is running. This means that the settings given to configure the Flow Compensation function may not be accurate when both pumps are running. The *Dual Pump Value Increase* setting applies an increase to the setpoint which will offset the additional losses associated with both pumps running.

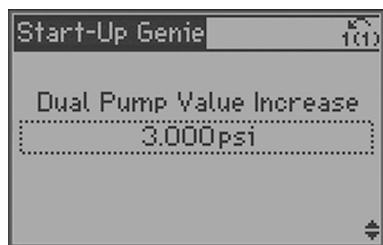

NOTE: This function is not intended for substitution of proper pipe layout and sizing according to Hydraulic Institute Standards.

6.5.3 Pump protection setup

Sleep mode

Sleep Mode protects the pump by turning off the pump in cases where there is no flow in the system. Sleep mode can be enabled or disabled. If Sleep Mode is disabled the pump will not turn off during a no flow condition if no other control devices are present to turn the pump off. The *Sleep Frequency/Low Limit [4-12]* and *Sleep Delay [22-24]* are set first. The *Sleep Frequency/Low Limit [4-12]* is the frequency that the pump has to reach or fall below in order to enter sleep mode. The Sleep Frequency is also the minimum frequency. The Sleep Delay is the amount of time the pump speed must be at or below the Sleep Frequency in order to enter Sleep Mode. Use this parameter to prevent the pump from entering sleep mode too soon.

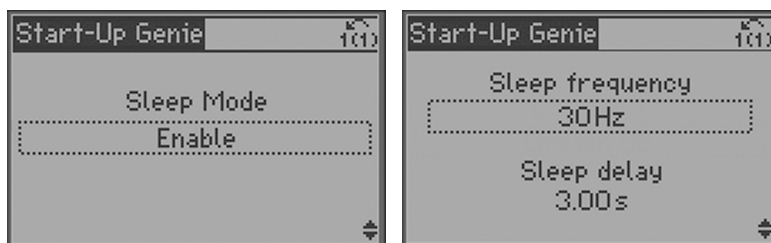

The *Restart Difference [22-44]* is the difference between the setpoint and the actual value that will cause the pump to restart (wake up) from sleep mode. This value is entered as a percent of the setpoint. For example, if the setpoint is 50 psi and a 10% Restart Difference is entered the pump will restart from sleep mode after the system pressure drops 5 psi below the set pressure (45 psi). If multiple setpoints are used then a Restart Difference must be entered for each setpoint.

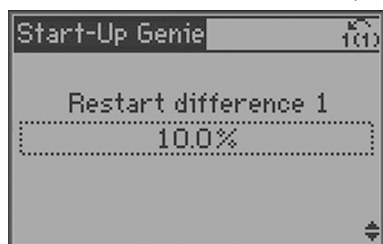

The *Minimum Run Time [22-40]* and *Minimum Sleep Time [22-41]* can be used to prevent rapid cycling. The *Minimum Run Time [22-40]* forces the pump to stay on and not enter sleep mode until the pump runs for the time entered in *Minimum Run Time [22-40]*. The *Minimum Sleep Time [22-41]* forces the pump to stay in sleep mode (turned off) for the time entered in *Minimum Sleep Time [22-41]*.



The *Setpoint Boost [22-45]* function can be used to further reduce cycle time. The Setpoint Boost function increases the system pressure before the pump enters sleep mode. To configure this function, exit the Genie and enter the parameter list by pressing the [Main Menu] key. Set parameter [22-45] *Setpoint Boost* and [22-46] *Maximum Boost Time*. *Setpoint Boost [22-45]* is the amount of increase in system pressure desired before the pump enters sleep mode. This is entered as a percent of setpoint. The Maximum Boost Time is a timeout function used to ensure the pump enters sleep mode. If the pump cannot achieve the setpoint + Setpoint Boost pressure before the Maximum Boost Time expires, the pump will enter sleep mode.

Flow check

The Flow Check function performs a test to determine whether flow or demand exists in the system. If a no flow condition exists in the system the pump will ramp down to Sleep Frequency and enter sleep mode. The Flow Check function is performed only when the pump is running. A diagram showing the Flow Check function is shown below. Motor speed is shown to illustrate the pump reaction to the Flow Check function. As shown in the diagram, when demand (flow) stops, the Flow Check function forces the system pressure to be higher than the Pressure Setpoint which forces the pump to enter sleep mode.

NOTE: This function is not available in Duplex Control mode.

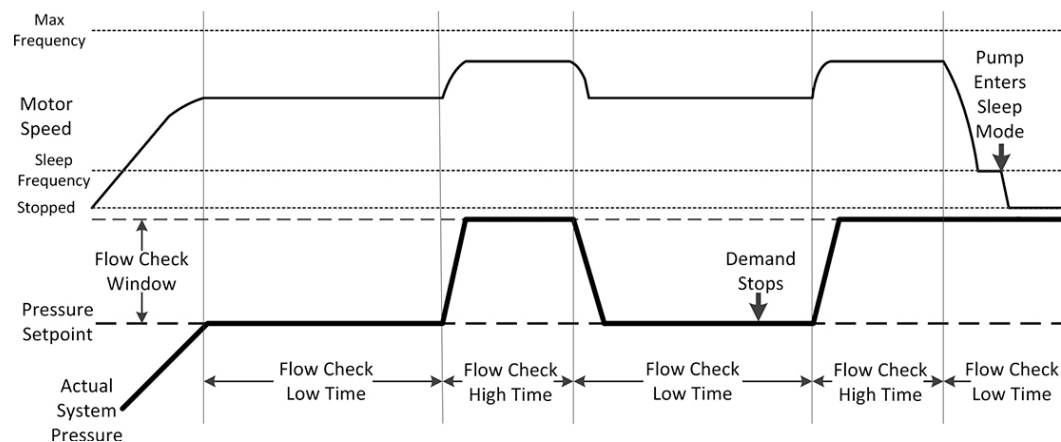
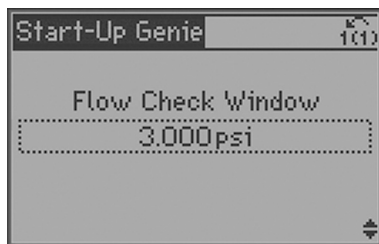

To configure the Flow Check function first set the Flow Check Window. The Flow Check Window is the amount of pressure increase that will be used during the Flow Check function test. This amount is added to the existing setpoint to create a new temporary setpoint. Next set the Flow Check Low Time and the Flow Check High Time. The Flow Check Low Time defines how long the controller will run at the setpoint before applying the value set in Flow Check Window. The Flow Check High Time defines how long the controller will run at setpoint plus the value set in Flow Check Window. These times are

limited between 10 and 300 seconds. Ensure Flow Check Low Time is set long enough to allow the pump to ramp down to the sleep frequency. Setting the Flow Check Low Time longer or equal to the *Ramp Down Time* [3-42] will ensure the pump has time to ramp to sleep during the Flow Check Low Time.



No Flow Power Calibration

A no flow condition can also be detected by monitoring the power consumption of the pump. Typically a pump's power consumption will drop when the pump is run at no flow. The graph shown below illustrates a typical pump power curve at the pump design flow and at no flow.

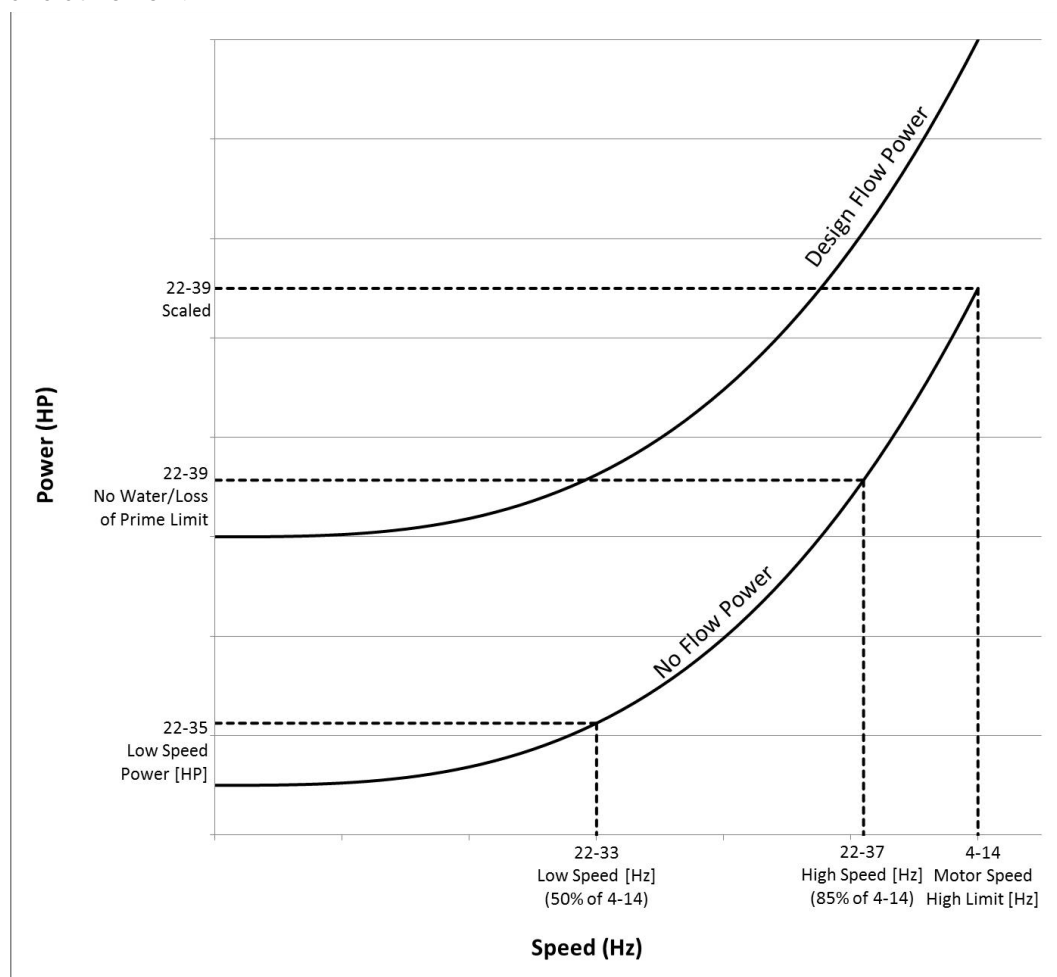

When the pump is operated at no flow, the power consumption will follow the no flow power curve for that specific pump. The controller monitors the power consumption of the pump. If the pump's power consumption falls to the no flow power curve, a no flow condition can be detected by the controller. In order to detect a no flow condition for various pumps, the no flow power curve needs to be programmed in to the drive. The No Flow Power Calibration Setup provides the method to program the no flow power curve in to the controller.

NOTE: Before beginning the No Flow Power Calibration Process ensure the *Sleep Frequency/Low Limit [4-12]* and the *Motor Speed High Limit [Hz] [4-14]* are set. These parameters are set as part of the Motor Setup.

NOTE: For the most accurate No-Flow Power Calibration data, run the setup after the system has reached normal operating temperature.



WARNING:

The No Flow Power Calibration Process requires the pump to be operated at no flow. This can produce high pressure within the system. Ensure the system piping and components are designed to withstand the suction pressure plus shutoff head pressure produced by the pump prior to starting the calibration process.

Select Enabled to begin the No Flow Power Calibration Setup.

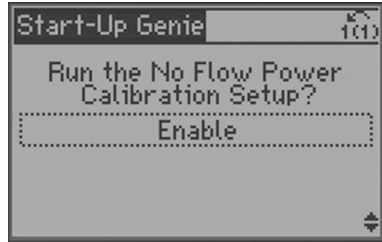

The first screen prompts to ensure the *Sleep Frequency/Low Limit [4-12]* and *Motor Speed High Limit [4-14]* have been set. If these points are not set the No Flow Power Calibration will not operate properly.

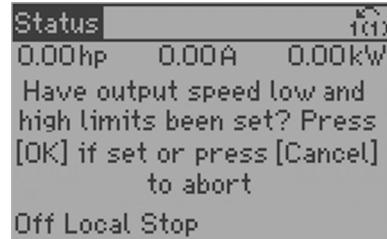

The next screen prompts to close all discharge valves and to press [Hand On] to begin the No Flow Power Calibration process. Doing this ensures the pump will operate at no flow/shutoff. If the pump does not operate at no flow during the setup, the calibration data will be invalid.

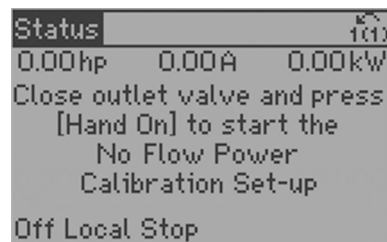

The controller will now begin running the pump while monitoring the power. In the first two steps the pump is operated at 85% of maximum speed defined at *Motor Speed High Limit [Hz] [4-14]* and the power to the pump is monitored and saved. The pump then operates at 50% of maximum speed and the power is monitored and saved. The no flow power curve is then constructed within the controller based on these 2 points using the affinity laws.

The No Flow Power Calibration Set-up is now complete. The power data can be saved by pressing [OK] and then the down arrow. If any issues were encountered during the calibration process discard the data by pressing [Cancel] and repeat the calibration process.

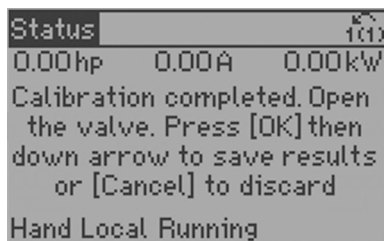

NOTE: Be sure to press [OK] then the down arrow to save the No Flow Power Calibration data. Pressing the down arrow ensures that all background calculations and parameter settings are performed properly.

NOTE: The No Flow Power Calibration Set-up configures the *No Water/Loss of Prime Limit [22-39]*. Do not modify the No Water/Loss of Prime Limit after the No Flow Power Calibration Set-up is completed. Modification of the *No Water/Loss of Prime Limit [22-39]* can cause the No Flow detection and No Water/Loss of Prime detection to malfunction.

In some cases the power calculation based on the calibration data taken during the No Flow Power Calibration Set-up may require adjustment. The *Power Correction Factor [22-31]* parameter allows the calculated power to be adjusted to avoid detection of a no flow condition while there is flow or to allow detection of a no flow condition while there is no flow in the system. If a no flow condition is detected while there is flow, the setting should be decreased. If a no flow condition is not detected while there is no flow, the setting should be increased above 100%.

No water/loss of prime

The No Water/Loss of Prime function is used to protect the pump against running dry and/or loss of prime. The function works by monitoring power at full speed and comparing the actual power to a preset limit. If the actual power falls below this preset limit for a specified amount of time, the No Water/Loss of Prime alarm is issued. If the No Water/Loss of Prime function is disabled, the pump will not be protected against running dry and/or loss of prime.

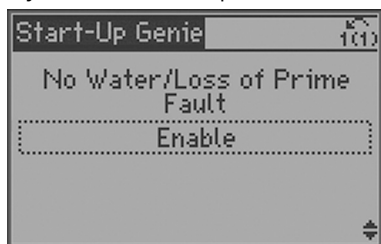

NOTE: In Duplex Control the No Water/Loss of Prime function is disabled by default on the lag pump. In Duplex Systems where pumps are fed from different sources the lag pump should be protected by using the Pump Protect Function. Refer to the Pump Protect Function for details.

NOTE: In Duplex Systems where pumps are fed from different sources and the lag pump is able to maintain the system pressure without reaching maximum speed, the No Water/Loss of Prime condition may not be detected on the lead pump. In this case it is recommended to delay the starting of the lag pump by setting the *Minimum Sleep Time [22-41]* on the lag pump greater than the *No Water/Loss of Prime Protection Delay [22-27]* plus the *Ramp Up Time [3-41]* of the lead pump. Be sure to set this on both controllers while set to lag if alternation is enabled.

The *No Water/Loss of Prime Limit [22-39]* is the no flow power value that corresponds to the speed entered in *High Speed [Hz] [22-37]*. The No Flow Power Calibration Set-up automatically enters 85% of the *Motor Speed High Limit [Hz] [4-14]* in *High Speed [Hz] [22-37]*.

The No Water/Loss of Prime function works by monitoring the pump power consumption at full speed, and the *No Water/Loss of Prime Limit [22-39]* corresponds the pump power consumption at 85% of full speed. The controller internally scales the *No Water/Loss of*

Prime Limit [22-39] based on the affinity laws to determine the actual power limit for the No Water/Loss of Prime function. Since pump power consumption changes with the cube of speed and the No Water/Loss of Prime Limit is entered as 85% of maximum speed, the controller scales the power entered in *No Water/Loss of Prime Limit [22-39]* by $(1/85\%)^3$ or 1.628 to determine the actual power limit used for the No Water/Loss of Prime function.

When the pump is running at full speed and the actual power consumed by the pump is less than or equal to this value for a specified amount of time, the No Water/Loss of Prime alarm is issued. It is recommended to set this value by performing the No-Flow Power Calibration Setup.

NOTE: If the Autoset function is used to configure the controller this value is set to 75% of the service factor HP multiplied by the 85% speed ratio cubed (or $(85\%)^3 = 0.614$) of the pump/motor combination. For example, for a 10HP pump/motor with a pump/motor service factor of 1.15 (the pump utilizes 100% of the service factor of the motor), the Autoset function sets the No Water/Loss of Prime Limit [22-39] to 5.29HP.

The *Power Correction Factor [22-31]* can be used to modify the internal scaling of the *No Water/Loss of Prime Limit [22-39]* in cases where nuisance tripping results or where a No Water/Loss of Prime condition is not detected. If nuisance tripping results, the *Power Correction Factor [22-31]* can be increased above 100%. Increasing the *Power Correction Factor [22-31]* will increase the scaling of the *No Water/Loss of Prime Limit [22-39]* so that a No Water/Loss of Prime condition is detected at a higher power. The amount of increase above 100% is dependent on the loading of the pump. If a No Water/Loss of Prime alarm is not issued when the pump has lost prime or runs dry the *Power Correction Factor [22-31]* can be decreased so that a No Water/Loss of Prime condition is detected at a lower power. The amount of decrease below 100% is dependent on the loading of the pump.

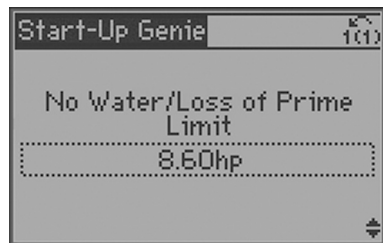

The No Water/Loss of Prime Restart function can be set to allow the controller to attempt to restart the pump after a specified amount of time. In order to enable this function a jumper wire must be installed between terminals 29 and 32. Refer to the *Common terminal wiring configurations* section in this manual for details on control terminal wiring. The default restart time is 10 minutes. Set this value based on the system requirements.



The *No Water/Loss of Prime Protection Delay [22-27]* is the time delay between detection of the No Water/Loss of Prime condition and the action of the No Water/Loss of Prime Alarm. The *No Water/Loss of Prime Protection Delay [22-27]* time can be extended to avoid nuisance tripping. Note that extending the time will allow the pump to run dry or without prime for the time specified.

NOTE: It is recommended to set the *No Water/Loss of Prime Protection Delay [22-27]* time shorter than the *Under Pressure Delay Time [22-51]*. This ensures a No Water/Loss of Prime condition will be detected properly before the Under Pressure function is triggered.

Under pressure function

The Under Pressure Function protects the pump and system by preventing the pump from running below a specified low pressure for a specified amount of time. This function can protect the pump from damage caused by running at runout flow and/or can protect the system from unexpected leakage such as from an open valve or ruptured pipe. Set the function to Alarm to trip the drive and issue an alarm message on the LCP during an Under Pressure condition. Set the function to Warning to issue a warning message on the LCP during an Under Pressure condition. Set the function to Off to disable the function.

NOTE: The Under Pressure Alarm will reset according to *Reset Mode [14-20]* and *Automatic Restart Time [14-21]*.

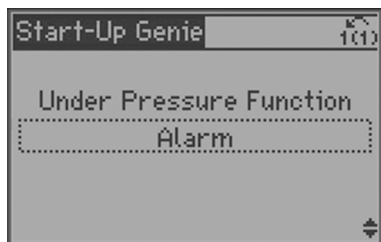

To configure this function the *Under Pressure Delay Time [22-51]* and *Under Pressure Difference [22-52]* must be set. The *Under Pressure Delay Time [22-51]* is the amount of time that the system pressure must be below the *Under Pressure Difference [22-52]* before issuing the Under Pressure alarm or warning.

NOTE: Setting the *Under Pressure Delay Time [22-51]* less than the *No Water/Loss of Prime Protection Delay [22-27]* will cause the Under Pressure Alarm to trip before the No Water/Loss of Prime Alarm in cases where the pressure drop in the system is due to the pump running dry or losing prime. To avoid this set the *Under Pressure Delay Time [22-51]* longer than the *No Water/Loss of Prime Protection Delay [22-27]*.

The *Under Pressure Difference [22-52]* is the difference between the setpoint pressure the actual pressure that will trigger the Under Pressure function. This pressure is set as a percent of the *[20-14] Maximum Reference/Feedback*. For example, the *Under Pressure Delay Time [22-51]* is set to 10 seconds, the *Under Pressure Difference [22-52]* is set to 10%, the pressure setpoint is set to 50 psi and the *[20-14] Maximum Reference/Feedback* is set to 300 psi. If the system pressure falls below 20 psi ($50 \text{ psi} - (10\% * 300 \text{ psi})$) for more than 10 seconds, the controller will issue an Under Pressure Alarm or Warning.

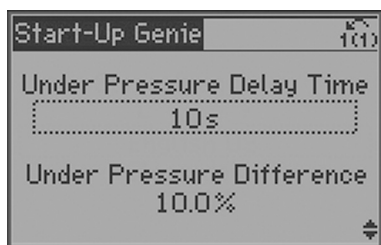

Pump protect function

The Pump Protect Function provides a way to stop the pump based on the state of an external protection device. The external device must be wired to DI 19 (parameter 5-11) or DI 27 (parameter 5-12), refer to the Common Terminal Wiring section in this manual for details. One side of the external device must be wired to 24V (terminals 12 or 13) and the other is wired to the digital input (terminal 19 for digital input 19 or terminal 27 for digital input 27). Refer to the *Common terminal wiring configurations* section in this manual for details on control terminal wiring.



NOTE: Only connect external devices with non-powered contacts to the digital inputs.

NOTE: Only DI 19 is available for the Pump Protect Function in Duplex Control.

The *Pump Protect Delay [22-00]* time can be configured to prevent false or nuisance tripping or the Pump Protect warning or alarm. When Pump Protect is enabled and the corresponding digital input is open for more than the time indicated in *Pump Protect Delay [22-00]*, the Pump Protect warning or alarm is issued. The same delay time is used for Pump Protect on DI 19 and DI 27.



The Pump Protect alarm will reset according to *Reset Mode [14-20]* and *Automatic Restart Time [14-21]*.

6.5.4 Digital input setup

Any unused digital input can be configured as part of the Digital Input Setup. A list of the digital inputs and their associated functions are shown below. The default function of a digital input can change based on the Operating Mode selected. Digital Input 18 is utilized as a Start function for all operating modes. This input has a dedicated function and cannot be configured in the Digital Input Setup. A separate table is given for the Duplex Control mode due to the specific functionality assigned to the digital inputs.



NOTICE:

Changing the function of any assigned digital input or output when set to Duplex Control Mode will cause the controller to malfunction.

Table 28: Digital input functionality based on operating mode

Digital I/O		Operating Mode			Description
Terminal Number	Parameter Number	Single Pump/ Constant Slave	Speed Control	Test Run Mode	
18	5-10	[8] Start	[8] Start	[14] Jog	Start/Stop digital input signal for the drive. Connect input to 24 V to start. Open the input to stop. This is a required connection. In Test Run Mode, this input starts the test run.
19	5-11	[0] No Operation	[0] No Operation	[0] No Operation	Unused digital input. This input can be configured for use as a Pump Protect Warning or Alarm Input. See Pump Protect section to enable the Warning or Alarm associated with the input.
27	5-12	[0] No Operation	[0] No Operation	[0] No Operation	Unused digital input for all models. This input can be configured for use as a Pump Protect Warning or Alarm input. See Pump Protect section to enable the Warning or Alarm associated with this input.
29	5-13/5-31	[63] No Water/ Loss of Prime Restart (CMP3)	[0] No Operation	[0] No Operation	Selectable for digital input or output. Default configuration is an output that is configured for use as a No Water/ Loss of Prime Restart signal in the Single Pump and Constant Slave mode. Refer to the Pump Protection section for details.

Digital I/O		Operating Mode			
Terminal Number	Parameter Number	Single Pump/ Constant Slave	Speed Control	Test Run Mode	Description
32	5-14	[1] Restart	[0] No Operation	[0] No Operation	Configured for use as a Reset for the No Water/Loss of Prime Restart function for Single Pump and Constant Slave modes. Refer to the Pump Protection section for details.
33	5-15	[23] SP1/SP2 Select	[23] SP1/SP2 Select	[23] SP1/SP2 Select	Digital input. Configured for use as a Setpoint 1/Setpoint 2 select (SP1/SP2)
20	–	Common	Common	Common	Common for digital inputs and reference for 24 V supply

Table 29: Digital input functionality based for duplex mode

Digital I/O		Duplex Control Mode		
Terminal Number	Parameter Number	Lead	Lag	Description
18	5-10	[8] Start	[8] Start	Start/Stop digital input signal for the drive. Connect input to 24 V to start. Open the input to stop. This is a required connection.
19	5-11	[0] No Operation	[0] No Operation	Unused digital input. This input can be configured for use as a Pump Protect Warning or Alarm input. See Pump Protect section to enable the Warning or Alarm associated with this input.

Digital I/O		Duplex Control Mode		
Terminal Number	Parameter Number	Lead	Lag	Description
27	5-12	Setpoint increase	Pump Exercise Input	When operating as the lead pump, this input will increase the setpoint when both pumps are on to compensate for the additional flow of the lag pump. This effectively performs a flow compensation function. When operating as a lag pump, this input acts as the Pump Exercise Input which will perform the Pump Exercise function. See Duplex Control in the Commissioning section of this manual for details.
29	5-13/5-31	I am Lead	I am Lead Inverse	Terminal 29 is configured as an output. This output is used to indicate which controller is the lead pump and which is the lag pump.
32	5-14	Slave Select	Slave Select	When this input is high, the other controller is operating as the lead pump. When high, this input will force the controller to become the lag pump or enter sleep mode if Duty Standby is enabled.
33	5-15	[23] SP1/SP2 Select	[23] SP1/SP2 Select	Digital input. Configured for use as a Setpoint 1/Setpoint 2 select (SP1/SP2). Open = SP1, Closed = SP2.
20	–	Common	Common	supply

6.5.5 Relay and analog output setup

The Relay and Analog Output Setup allows configuration of the onboard relays and analog output signal.



NOTE: If Constant Slave Mode is enabled the relays are used to control the fixed speed pumps. Changing the relay function with Constant Slave Mode enabled can cause the Constant Slave Controller to malfunction.

Relay outputs

To configure the relay set the relay function and the relay on delay. The relay function configures when the relay will change state. For example, when set to 'No Alarm', the relay will change state from the inactive to the active state when no alarms exist in the system. In the inactive state COM = NC and in the active state COM = NO. The relay on delay time is the time between the relay function trigger and when the relay changes state. For example, if the relay function is set to 'Running' and the delay time is set to 10 seconds, the relay will change state 10 seconds after the pump starts running. Relay 1 function is programmed as array parameter 5-40.0. Relay 2 function is programmed as part of array parameter 5-40.1. Relay 1 On Delay is programmed as part of array parameter 5-41.0. Relay 2 On Delay is programmed as part of array parameter 5-41.1.



The Relay Function screen is an array parameter screen. Refer to Programming the Controller section for details on how to program an array parameter screen.

The relay function options are shown in the table below.

Option	Function
[0]*	No operation
[1]	Control ready
[2]	Drive ready
[3]	Drive rdy/rem ctrl
[4]	Standby / no warning
[5]*	Running (Relay 2 Default)
[6]	Running / no warning
[8]	Run on ref/no warn
[9]	Alarm
[10]	Alarm or warning
[11]	At torque limit
[12]	Out of current range
[13]	Below current, low
[14]	Above current, high
[15]	Out of speed range
[16]	Below speed, low
[17]	Above speed, high
[18]	Out of feedb. range
[19]	Below feedback, low
[20]	Above feedback, high
[21]	Thermal warning
[25]	Reverse
[26]	Bus OK

Option	Function
[27]	Torque limit & stop
[28]	Brake, no brake war
[29]	Brake ready, no fault
[30]	Brake fault (IGBT)
[35]	Pump Protect
[36]	Control word bit 11
[37]	Control word bit 12
[40]	Out of ref range
[41]	Below reference, low
[42]	Above ref, high
[45]	Bus ctrl.
[46]	Bus ctrl, 1 if timeout
[47]	Bus ctrl, 0 if timeout
[60]	Comparator 0
[61]	Comparator 1
[62]	Comparator 2
[63]	Comparator 3
[64]	Comparator 4
[65]	Comparator 5
[70]	Logic rule 0
[71]	Logic rule 1
[72]	Logic rule 2
[73]	Logic rule 3
[74]	Logic rule 4
[75]	Logic rule 5
[80]	SL digital output A
[81]	SL digital output B
[82]	SL digital output C
[83]	SL digital output D
[84]	SL digital output E
[85]	SL digital output F
[160]*	No alarm (Relay 1 Default)
[161]	Running reverse
[165]	Local ref active
[166]	Remote ref active
[167]	Start command act.
[168]	Hand / Off
[169]	Auto mode
[180]	Clock Fault
[181]	Prev. Maintenance
[189]	External Fan Control
[190]	No Flow
[191]	No Water/Loss of Prime
[192]	Under Pressure

Option	Function
[193]	Sleep Mode
[194]	Broken Belt
[195]	Bypass Valve Control
[196]	Fire Mode
[197]	Fire Mode was Act.
[198]	Drive Bypass
[211]	Lead Pump Alternate1
[212]	Fixed Speed Pump 1
[213]	Fixed Speed Pump 2

Analog output

The analog output (AO 42, parameter 6-50) can be configured to output various controller parameters. This output is a current output (0-20mA or 4-20mA). Refer to the Common Terminal Wiring section in this manual for details on wiring. The list of analog output configuration options is shown below.

Option	Function	
[0]*	No operation	
[100]	Output freq. 0-100	0-100 Hz, (0-20 mA)
[101]	Reference Min-Max	Minimum reference – Maximum Reference, (0-20 mA)
[102]	Feedback +-200%	-200% to +200% of [20-14] Maximum Reference/Feedb., (0-20 mA)
[104]	Torque 0-Tlim	0-Torque limit ([4-16] Torque Limit Motor Mode), (0-20 mA)
[105]	Torque 0-Tnom	0-Motor rated torque, (0-20 mA)
[106]	Power 0-Pnom	0-Motor rated power, (0-20 mA)
[107]*	Speed 0-HighLim	0-Speed High Limit ([4-13] Motor Speed Limit [RPM] and [4-14] Motor Speed High Limit [Hz]), (0-20 mA)
[113]	Ext. Closed Loop 1	0-100%, (0-20 mA)
[114]	Ext. Closed Loop 2	0-100%, (0-20 mA)
[115]	Ext. Closed Loop 3	0-100%, (0-20 mA)
[130]	Out frq 0-100 4-20mA	0-100 Hz
[131]	Reference 4-20mA	Minimum Reference – Maximum Reference
[132]	Feedback 4-20mA	-200% to +200% of [20-14] Maximum Reference/Feedb.
[133]	Motor cur. 4-20 mA	0-Inverter Max. Current ([16-37] Inv. Max. Current)
[134]	Torq.0-lim 4-20 mA	0-Torque limit ([4-16] Torque Limit Motor Mode)
[135]	Torq.0-nom 4-20 mA	0-Motor rated torque
[136]	Power 4-20 mA	0-Motor rated power
[137]	Speed 4-20 mA	0-Speed High Limit ([4-13] and [4-14])
[139]	Bus ctrl.	0-100%, (0-20 mA)
[140]	Bus ctrl. 4-20 mA	0-100%

Option		Function
[141]	Bus ctrl. t.o.	0-100%, (0-20 mA)
[142]	Bus ctrl t.o. 4-20 mA	0-100%
[143]	Ext. Cl. 1 4-20 mA	0-100%
[144]	Ext. Cl. 2 4-20 mA	0-100%
[145]	Ext. Cl. 3 4-20 mA	0-100%

6.5.6 Communication setup

The Genie can be used to setup the on board fieldbus communications through the RS485 port. Various protocols are supported. Select the desired protocol from the first menu. Supported protocols include Modbus RTU, Metasys N2, FLN, BACnet, FC Option and FCMC. The FC Option is used when the onboard RS485 port is connected to a gateway such as a BACnet gateway. The FCMC protocol is used for downloading software to the controller or parameters from the MCT10 tool.



A slightly different set of parameters must be configured to setup each protocol. Use the Genie to guide the setup of each protocol.

Copy to LCP

The LCP can be used to store or save a parameter configuration. It is recommended to copy all parameters to the LCP after commissioning the controller or prior to making adjustments during troubleshooting. Select [Yes] from the menu in the Genie then and press [OK] to begin copying parameters to the LCP. Parameter 0-50 LCP Copy can also be used to copy all parameters from all setups to the LCP.

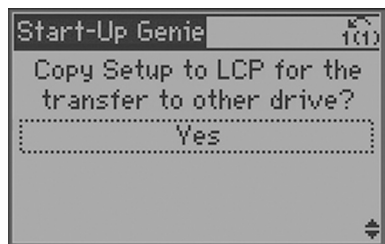

Copy from LCP

After parameters are stored to the LCP they can be downloaded to the same controller to restore the previous state of the controller or to another controller for fast setup. Either all parameters or only size independent parameters can be downloaded from the LCP to the controller. Select [All] from the *Copy Setup from LCP* menu to download all parameters from the LCP to the controller. Select [Application only] from the *Copy Setup from LCP* menu to download all size independent parameters from the LCP to the controller.

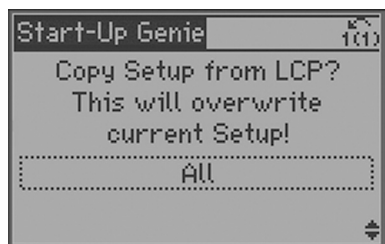

NOTE: Some settings made in the Start-Up Genie are not stored as a drive parameter. These settings will not be copied to or from the LCP. These settings include Motor Type, Operating Mode, Application Type, Number Feedback Sources and Number of Setpoints. Be sure to enter the Start-Up Genie and configure these settings before using the Copy Setup from LCP function.

The LCP can be used to store or save a parameter configuration. It is recommended to copy all parameters to the LCP after commissioning the controller or prior to making adjustments during troubleshooting. Select [Yes] from the menu in the Genie then and press [OK] to begin copying parameters to the LCP. Parameter 0-50 LCP Copy can also be used to copy all parameters from all setups to the LCP.

6.5.7 Automatic motor adaptation

Automatic motor adaptation (AMA) is a test procedure that measures the electrical characteristics of the motor to optimize compatibility between the frequency converter and the motor.

- The frequency converter builds a mathematical model of the motor for regulating output motor current. The procedure also tests the input phase balance of electrical power. It compares the motor characteristics with the data entered in parameters 1-20 to 1-25.
- The motor shaft does not turn and no harm is done to the motor while running the AMA.
- Some motors may be unable to run the complete version of the test. In that case, select [2] *Enable reduced AMA*.
- If an output filter is connected to the motor, select *Enable reduced AMA*.
- If warnings or alarms occur, see Warnings and alarms section for details.
- Run this procedure on a cold motor for best result.

NOTE: The AMA algorithm does not work when using PM motors.

To run AMA:

1. Press [Main Menu] to access parameters.
2. Scroll to parameter group 1-** Load and Motor
3. Press [OK].
4. Scroll to parameter group 1-2* Motor Data.
5. Press [OK].
6. Scroll to 1-29 Automatic Motor Adaptation (AMA).
7. Press [OK].
8. Select [1] Enable complete AMA.
9. Press [OK].
10. Follow on-screen instructions.
11. The test will run automatically and indicate when it is complete.

Date and time setting

The date and time can be set on the controller to help diagnostics and fault logging. To set the clock, enter the parameter list by pressing [Main Menu]. Use the up and down arrows to highlight 0-** Operation/Display menu and press [OK] to enter the menu. Next, use the up and down arrows to highlight 0-7* *Clock Settings* and press [OK] to select. Use the up and down arrows to select parameter 0-70 *Date and Time*. Press [OK] to enabling editing of the Date and Time parameter. First set the time. Use the up and down arrows to set the minutes. Then use the left arrow key to scroll left to the hours. Use the up and down arrows to set the hour of the day. To change to PM, press the up arrow key until the desired hours and the letter P (found between the minutes and day of the week) are shown on the display. Next, scroll to the left to set the date. The day of the week on the right side will update according to the date selected. Press [OK] to save the changes.

NOTE: If the power to the unit is lost, the date and time will reset to factory defaults. Battery backup for real time clock is available on the Analog I/O Option Card (Input/Output Option "A" or Repair part number 9K653).

6.6 Basic operational programming

Required initial frequency converter programming

NOTE: If the Start-Up Genie is run, ignore the following.

Frequency converters require basic operational programming before running for best performance. Basic operational programming requires entering motor-nameplate data for the motor being operated and the minimum and maximum motor speeds. Enter data in accordance with the following procedure. Parameter settings recommended are intended for start up and checkout purposes. Application settings may vary. See the Local Control Panel section for detailed instructions on entering data through the LCP.

Enter data with power ON, but before operating the frequency converter.

1. Press [Main Menu] twice on the LCP.
2. Use the navigation keys to scroll to parameter group 0-** Operation/Display and press [OK].

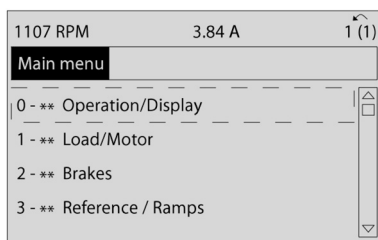

Figure 90: Main menu

3. Use navigation keys to scroll to parameter group 0-0* Basic settings and press [OK].

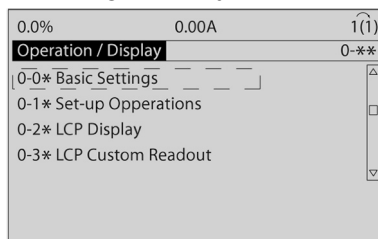

Figure 91: Operation/display

4. Use navigation keys to scroll to 0-3 Regional Settings and press [OK].

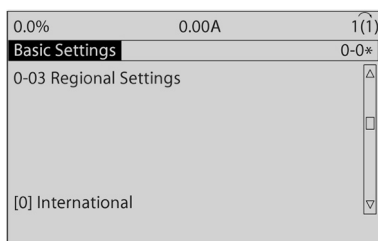

Figure 92: Basic settings

5. Use navigation keys to select [0] International or [1] North America as appropriate and press [OK]. This changes the default settings for a number of basic parameters. See 5.4 International/North American Default Parameter Settings for a complete list.)
6. Press [Quick Menu] on the LCP.
7. Use the navigation keys to scroll to parameter group Q2 Quick Setup and press [OK].

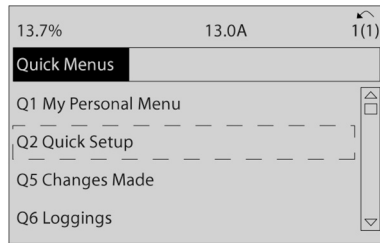

Figure 93: Quick menus

8. Select language and press [OK].
9. A jumper wire should be in place between control terminals 12 and 27. If this is the case, leave 5-12 *Terminal 27 Digital Input* at factory default. Otherwise select *No Operation*. For frequency converters with an optional Xylem bypass, no jumper wire is required.
10. 3-02 *Minimum Reference*
11. 3-03 *Maximum Reference*
12. 3-41 *Ramp 1 Ramp Up Time*
13. 3-42 *Ramp 1 Ramp Down Time*
14. 3-13 *Reference Site*. Linked to Hand/Auto* Local

6.7 Induction motor setup

Enter the motor data in parameters 1-20/1-21 to 1-25. The information can be found on the motor nameplate.

1.
 - 1-20 *Motor Power [kW]* or 1-21 *Motor Power [HP]*
 - 1-22 *Motor Voltage*
 - 1-23 *Motor Frequency*
 - 1-24 *Motor Current*
 - 1-25 *Motor Nominal Speed*

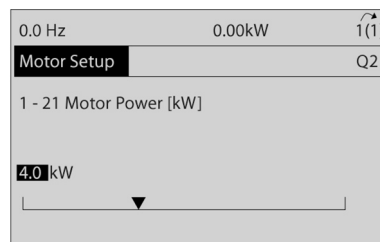

Figure 94: Motor setup

6.8 PM motor setup



CAUTION:

Only use PM motor with fans and pumps.



WARNING:

WINDMILLING! Unintended rotation of permanent magnet motors causes a risk of personal injury and equipment damage. Ensure permanent magnet motors are blocked to prevent unintended rotation.

Initial programming steps

1. Activate PM motor operation 1-10 *Motor Construction*, select [1] *PM, non salient SPM*
2. Make sure to set 0-02 *Motor Speed Unit* to [0] *RPM*

Programming motor data

After selecting PM motor in *1-10 Motor Construction*, the PM motor-related parameters in parameter groups *1-2* Motor Data*, *1-3* Adv. Motor Data* and *1-4** are active.

The information can be found on the motor nameplate and in the motor data sheet.

The following parameters must be programmed in the listed order:

1. *1-24 Motor Current*
2. *1-26 Motor Cont. Rated Torque*
3. *1-25 Motor Nominal Speed*
4. *1-39 Motor Poles*
5. *1-30 Stator Resistance (Rs)*
 - a. Enter line to common stator winding resistance (Rs). If only line-line data are available, divide the line-line value with 2 to achieve the line to common (starpoint) value.
 - b. It is also possible to measure the value with an ohmmeter, which will also take the resistance of the cable into account. Divide the measured value by 2 and enter the result.
6. *1-37 d-axis Inductance (Ld)*
 - a. Enter line to common direct axis inductance of the PM motor.
 - b. If only line-line data are available, divide the line-line value with 2 to achieve the line-common (starpoint) value.
 - c. It is also possible to measure the value with an inductance meter, which will also take the inductance of the cable into account. Divide the measured value by 2 and enter the result.
7. *1-40 Back EMF at 1000 RPM*
 - a. Enter line to line back EMF of PM Motor at 1000 RPM mechanical speed (RMS value). Back EMF is the voltage generated by a PM motor when no drive is connected and the shaft is turned externally. Back EMF is normally specified for nominal motor speed or for 1000 RPM measured between two lines. If the value is not available for a motor speed of 1000 RPM, calculate the correct value as follows: If back EMF is e.g. 320 V at 1800 RPM, it can be calculated at 1000 RPM as follows: $\text{Back EMF} = (\text{Voltage} / \text{RPM}) * 1000 = (320/1800) * 1000 = 178$. This is the value that must be programmed for 1-40 Back EMF at 1000 RPM.

Test motor operation

1. Start the motor at low speed (100 to 200 RPM). If the motor does not turn, check installation, general programming and motor data.
2. Check if start function in *1-70 PM Start Mode* fits the application requirements.

Rotor detection

This function is the recommended choice for applications where the motor starts from standstill e.g. pumps or conveyors. On some motors, an acoustic sound is heard when the impulse is sent out. This does not harm the motor.

Parking

This function is the recommended choice for applications where the motor is rotating at slow speed eg. windmilling in fan applications. *2-06 Parking Current* and *2-07 Parking Time* can be adjusted. Increase the factory setting of these parameters for applications with high inertia.

Start the motor at nominal speed. In case the application does not run well, check the VVC^{plus} PM settings.

Recommendations in different applications can be seen in the following table:

Table 30: Recommendations in different applications

Application	Settings
Low inertia applications $I_{Load}/I_{Motor} < 5$	<ul style="list-style-type: none"> • 1-17 Voltage filter time const. to be increased by factor 5 to 10 • 1-14 Damping Gain should be reduced • 1-66 Min. Current at Low Speed should be reduced (<100%)
Low inertia applications $5 > I_{Load}/I_{Motor} > 5$	Keep calculated values
High inertia applications $I_{Load}/I_{Motor} > 50$	1-14 Damping Gain, 1-15 Low Speed Filter time Const. and 1-16 High Speed Filter Time Const. should be increased
High load at low speed <30% (rated speed)	1-17 Voltage filter time const. should be increased 1-66 Min. Current at Low Speed should be increased (>100% for longer time can overheat the motor)

If the motor starts oscillating at a certain speed, increase 1-14 Damping Gain. Increase the value in small steps.

Depending on the motor, a good value for this parameter can be 10% or 100% higher than the default value.

Starting torque can be adjusted in 1-66 Min. Current at Low Speed. 100% provides nominal torque as starting torque.

6.9 Check motor rotation

Before running the frequency converter, check the motor rotation. The motor will run briefly at 5 Hz or the minimum frequency set in 4-12 Motor Speed Low Limit [Hz].

1. Press [Quick Menu].
2. Scroll to Q2 Quick Setup.
3. Press [OK].
4. Scroll to 1-28 Motor Rotation Check.
5. Press [OK].
6. Scroll to [1] Enable.
The following text will appear: *NOTE! Motor may run in wrong direction.*
7. Press [OK].
8. Follow the on-screen instructions.

To change the direction of rotation, remove power to the frequency converter and wait for power to discharge. Reverse the connection of any two of the three motor cables on the motor or frequency converter side of the connection.

6.10 Local-control test



CAUTION:

MOTOR START. Ensure that the motor, system and any attached equipment are ready for start. It is the responsibility of the user to ensure safe operation under any condition.

NOTE: The [Hand On] key provides a local start command to the frequency converter. The [Off] key provides the stop function.

When operating in local mode, [▲] and [▼] increase and decrease the speed output of the frequency converter. [◀] and [▶] move the display cursor in the numeric display.

1. Press [Hand On].
2. Accelerate the frequency converter by pressing [▲] to full speed. Moving the cursor left of the decimal point provides quicker input changes.
3. Note any acceleration problems.
4. Press [Off].
5. Note any deceleration problems.

If acceleration problems were encountered:

- If warnings or alarms occur, see Warnings and Alarms section for details.
- Check that motor data is entered correctly.
- Increase the ramp-up time in *3-41 Ramp 1 Ramp Up Time*
- Increase current limit in *4-18 Current Limit*
- Increase torque limit in *4-16 Torque Limit Motor Mode*

If deceleration problems were encountered:

- If warnings or alarms occur, see Warnings and Alarms section for details.
- Check that motor data is entered correctly.
- Increase the ramp-down time in *3-42 Ramp 1 Ramp Down Time*
- Enable overvoltage control in *2-17 Over-voltage Control*

See *Local Control Panel* for details on resetting the frequency converter after a trip.

6.11 System start-up

The procedure in this section requires user-wiring and application programming to be completed. Application set-up examples are intended to help with this task. Other aids to application set-up are listed in 1.2 Additional Resources. The following procedure is recommended after application set-up by the user is completed.

NOTICE:

MOTOR START. Ensure that the motor, system and any attached equipment is ready for start.

1. Press [Auto On].
2. Ensure that external control function are properly wired to the frequency converter and all programming is completed.
3. Apply an external run command.
4. Adjust the speed reference throughout the speed range.
5. Remove the external run command.
6. Note any problems.

If warning or alarms occur, see Warnings and Alarms section for details on troubleshooting.

6.12 Acoustic noise or vibration

If the motor or the equipment driven by the motor, for example a pump impeller blade, is making noise or vibrations at certain frequencies, try the following:

- Speed Bypass, parameter group 4-6*
- Over-modulation, *14-03 Overmodulation* set to off
- Switching pattern and switching frequency parameter group 14-0*
- Resonance Dampening, *1-64 Resonance Dampening*

7 Warnings and alarms

7.1 System monitoring

The frequency converter monitors:

- The condition of its input power
- Output
- Motor factors
- Other system performance

A warning or alarm may not signal a frequency converter problem. It can also indicate the following:

- Failure conditions from input voltage
- Motor load
- Temperature
- External signals
- Other areas monitored by the frequency converter's internal logic

Be sure to check those areas exterior to the frequency converter as indicated in the warning or alarm.

7.2 Warning and alarm types

Warnings

A warning is issued when an alarm condition is impending or when an abnormal operating condition is present and may result in the frequency converter issuing an alarm. A warning clears by itself when the abnormal condition is removed.

Alarms

An alarm is issued when the frequency converter is tripped, that is, the frequency converter suspends operation to prevent frequency converter or system damage. The motor will coast to a stop. The frequency converter logic will continue to operate and monitor the frequency converter status. After the fault condition is remedied, the frequency converter can be reset. It will be ready to start operation again.

A trip can be reset in any of 4 ways:

- Press [Reset] on the LCP
- Digital reset input command
- Serial communication reset input command
- Auto reset

An alarm that causes the frequency converter to trip-lock requires that input power is cycled. The motor will coast to a stop. The frequency converter logic will continue to operate and monitor the frequency converter status. Remove input power to the frequency converter and correct the cause of the fault, then restore power. This action puts the frequency converter into a trip condition as described above and may be reset in any of those 4 ways.

7.3 Warning and alarm displays

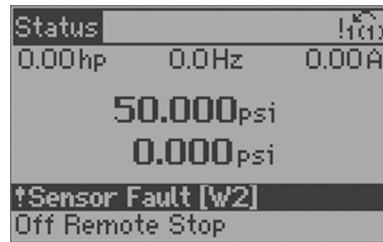

Figure 95: Warning display

An alarm or trip-lock alarm will flash along with the alarm number.

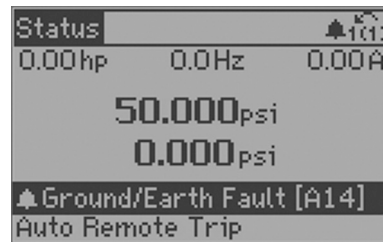

Figure 96: Alarm display

In addition to the text and alarm code on the frequency converter LCP, there are three status indicator lights.

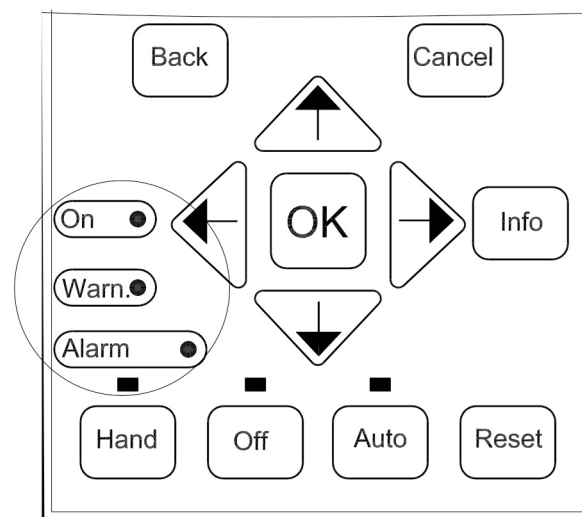

Figure 97: Status indicator lights

Table 31: Status indicator lights explanations

	Warning LED	Alarm LED
Warning	On	Off
Alarm	Off	On (Flashing)
Trip-Lock	On	On (Flashing)

Warnings/Alarm messages

A warning or an alarm is signaled by the relevant LED on the front of the frequency converter and indicated by a code on the display.

A warning remains active until its cause is no longer present. Under certain circumstances, operation of the motor may still be continued. Warning messages may be critical, but are not necessarily so.

In the event of an alarm, the frequency converter trips. Reset the alarm to resume operation once the cause has been rectified.

Three ways to reset:

- Press [Reset].
- Via a digital input with the "Reset" function.
- Via serial communication/optional fieldbus.

NOTE: After a manual reset pressing [Reset], press [Auto On] to restart the motor.

If an alarm can't be reset, the reason may be that its cause has not been rectified, or the alarm is trip-locked.

Alarms that are trip-locked offer additional protection, meaning that the mains supply must be switched off before the alarm can be reset. After being switched back on, the frequency converter is no longer blocked and can be reset as described above once the cause has been rectified.

Alarms that are not trip-locked can also be reset using the automatic reset function in [14-20] *Reset Mode* (Warning: Automatic wake-up is possible).

In some cases a warning will occur before an alarm is issued. This is possible, for instance, in [1-90] *Motor Thermal Protection*. After an alarm or trip, the motor continues to coast, and the alarm and warning flash. Once the problem has been rectified, only the alarm continues flashing until the frequency converter is reset.

NOTE: No missing motor phase detection (numbers 30-32) and no stall detection is active when [1-10] *Motor Construction* is set to [1] PM non salient SPM.

The following table defines whether a warning is issued before an alarm, and whether the alarm trips the unit or trip locks the unit.

Table 32: Alarm/Warning code list

Number	Description	Warning	Alarm/Trip	Alarm/Trip Lock	Parameter Reference
1	10 volts low	X			
2	Sensor Fault	(X)	(X)		[6-01] Sensor FaultTimeout Function
3	No motor	(X)			[1-80] Function at Stop
4	Input Phase Loss	(X)	(X)	(X)	[14-12] Function at Sensor Fault
5	DC link voltage high	X			
6	DC link voltage low	X			
7	DC overvoltage	X	X		
8	DC undervoltage	X	X		
9	Inverter overloaded	X	X		
10	Motor ETR over-temperature	(X)	(X)		[1-90] Motor Thermal Protection
11	Motor thermistor over temperature	(X)	(X)		[1-90] Motor Thermal Protection
12	Torque limit	X	X		
13	Over current	X	X	X	
14	Ground/earth fault	X	X		
15	Hardware mismatch		X	X	
16	Short circuit		X	X	

Number	Description	Warning	Alarm/Trip	Alarm/Trip Lock	Parameter Reference
17	Control word timeout	(X)	(X)		[8-04] Control Word Timeout Function
18	Start Failed		X		[1-77] Compressor Start Max Speed [RPM], [1-79] Compressor Start Max Time to Trip, [1-03] Torque Characteristics
20	Temp. Input Error				
21	Param error				
22	Hoist Mech. Brake	(X)	(X)		Parameter group 2-2*
23	Internal fans	X			
24	External fans	X			
25	Brake resistor short-circuited	X			
26	Brake resistor power limit	(X)	(X)		[2-13] Brake Power Monitoring
27	Brake chopper short-circuited	X	X		
28	Brake check	(X)	(X)		[2-15] Brake Check
29	Heatsink temp	X	X	X	
30	Motor phase U missing	(X)	(X)	(X)	[4-58] Missing Motor Phase Function
31	Motor phase V missing	(X)	(X)	(X)	[4-58] Missing Motor Phase Function
32	Motor phase W missing	(X)	(X)	(X)	[4-58] Missing Motor Phase Function
33	Inrush fault		X	X	
34	Fieldbus communication fault	X	X		
35	Option fault				
36	Mains failure	X	X		
37	Phase imbalance		X		
38	Internal fault		X	X	
39	Heatsink sensor		X	X	
40	Overload of Digital Output Terminal 27	(X)			[5-00] Digital I/O Mode, [5-01] Terminal 27 Mode
41	Overload of Digital Output Terminal 29	(X)			[5-00] Digital I/O Mode, [5-02] Terminal 29 Mode
42	Ovrlld X30/6-7	(X)			
43	Ext. Supply (option)				
45	Earth Fault 2	X	X		
46	Pwr. card supply		X	X	
47	24 V supply low	X	X	X	
48	1.8 V supply low		X	X	
49	Speed limit		X		[1-86] Trip Speed Low [RPM]

Number	Description	Warning	Alarm/Trip	Alarm/Trip Lock	Parameter Reference
50	AMA calibration failed		X		
51	AMA check U_{nom} and I_{nom}		X		
52	AMA low I_{nom}		X		
53	AMA motor too big		X		
54	AMA motor too small		X		
55	AMA parameter out of range		X		
56	AMA interrupted by user		X		
57	AMA time-out		X		
58	AMA internal fault	X	X		
59	Current limit	X			
60	Pump Protect	X	X		
61	Feedback Error	(X)	(X)		[4-30] Motor Feedback Loss Function
62	Output Frequency at Maximum Limit	X			
63	Mechanical Brake Low		(X)		[2-20] Release Brake Current
64	Voltage Limit	X			
65	Control Board Over-temperature	X	X	X	
66	Heat sink Temperature Low	X			
67	Option Configuration has changed		X		
68	Safe Stop	(X)	(X) ¹⁾		[5-19] Terminal 37 Safe Stop
69	pwr. Card Temp		X	X	
70	Illegal FC configuration			X	
71	PTC 1 Safe Stop				
72	Dangerous failure				
73	Safe Stop Auto Restart	(X)	(X)		[5-19] Terminal 37 Safe Stop
74	PTC Thermistor			X	
75	Illegal Profile Sel.		X		
76	Power Unit Setup	X			
77	Reduced power mode	X			[14-59] Actual Number of Inverter Units
78	Tracking Error	(X)	(X)		[4-34] Tracking Error Function
79	Illegal PS config		X	X	
80	Drive initialized to Default value		X		
81	CSIV corrupt		X		

Number	Description	Warning	Alarm/Trip	Alarm/Trip Lock	Parameter Reference
82	CSIV parameter error		X		
83	Illegal Option Combination			X	
84	No Safety Option		X		
85	Dang fail PB				
86	Dang fail DI				
88	Option Detection			X	
89	Mechanical Brake Sliding	Z			
90	Feedback Monitor	(X)	(X)		[17-61] Feedback Signal Monitoring
91	Analog input 54 wrong settings			X	5202
92	No Flow	X	X		22-2*
93	No water / loss of prime	X	X		22-2*
94	Under pressure	X	X		22-5*
95	Broken Belt	X	X		22-6*
96	Start Delayed	X			22-7*
97	Stop Delayed	X			22-7*
98	Clock Fault	X			0-7*
102	Too many CAN objects				
103	Illegal axis num.				
104	Mixing fans				
105	Error not reset				
106	HOME not done				
107	Home vel zero				
108	Position error				
109	Index not found				
110	Unknown cmd.				
111	SW end limit				
112	Unknown param				
113	FC not enabled				
114	Too many loops				
115	Par. save failed				
116	Param. memory				
117	Progr. memory				
118	Reset by CPU				
119	User abort.				
121	No more SDO channels				
125	HW end limit				
149	Too many inter.				
150	No ext. 24 V				
151	GOSUB > limit				

Number	Description	Warning	Alarm/Trip	Alarm/Trip Lock	Parameter Reference
152	Return @ limit				
154	D.out overload				
155	LINK failed				
156	Illegal double arg.				
160	Internal Intr. error				
162	Memory error				
163	ATEX ETR cur.lim.warning	X			
164	ATEX ETR cur.lim.alarm		X		
165	ATEX ETR freq.lim.warning	X			
166	ATEX ETR freq.lim.alarm		X		
201	Fire M was Active				
202	Fire M Limits Exceeded				
203	Missing Motor				
204	Locked Rotor				
243	Brake IGBT	X	X		
244	Heatsink temp	X	X	X	
245	Heatsink sensor		X	X	
246	Pwr. card supply				
247	Pwr. card temp		X	X	
248	Illegal PS config		X	X	
250	New spare parts			X	
251	New Type Code		X	X	

(X) Dependent on parameter
1) Cannot be Auto reset via 14-20 Reset Mode

A trip is the action following an alarm. The trip coasts the motor and is reset by pressing [Reset] or by a digital input (parameter group 5-1* *Digital Inputs* [1]). The origin event that caused the alarm cannot damage the frequency converter or cause dangerous conditions. A trip lock is an action when an alarm occurs, which could damage the frequency converter or connected parts. A trip lock situation can only be reset by a power cycling.

Table 33: LED indication

Warning	Yellow
Alarm	Flashing red
Trip locked	Yellow and red

Table 34: Description of Alarm word, Warning word and Extended Status word

Bit	Hex	Dec	Alarm word	Alarm word 2	Warning word	Warning word 2	Extended Status word	Extended Status word 2
Alarm Word Extended Status Word								
0	0000001	1	Brake Check (A28)	ServiceTrip, read/write	Brake Check (W28)	Start Delayed	Ramping	Off

Bit	Hex	Dec	Alarm word	Alarm word 2	Warning word	Warning word 2	Extended Status word	Extended Status word 2
Alarm Word Extended Status Word								
1	00000002	2	Pwr.card temp (A69)	ServiceTrip, (reserved)	Pwr.card temp (A69)	Stop Delayed	AMA Running	Hand/Auto
2	00000004	4	Ground/Earth Fault (A14)	ServiceTrip, Typecade/sparepart	Ground/Earth Fault (W14)	reserved	Start CW/CCW start_possible is active, when the DI selections [12] OR [13] are active and the requested direction matches the reference sign	Profibus OFF1 active
3	00000008	8	Ctrl.Card Temp (A65)	ServiceTrip, (reserved)	Ctrl.Card Temp (W65)	reserved	Slow Down slow down command active, e.g. via CTW bit 11 oe DI	Profibus OFF2 active
4	00000010	16	Ctrl. Word TO (A17)	ServiceTrip, (reserved)	Ctrl. Word TO (W17)		Catch Up catch up comand active, e.g. via CTW bit 12 or DI	Profibus OFF3 active
5	00000020	32	Over Current (A13)	reserved	Over Current (W13)	reserved	Feedback High feedback > 4-57	Relay 123 active
6	00000040	64	Torque Limit (12)	reserved	Torque Limit (W12)	reserved	Feedback Low feedback < 4-56	Start Prevented
7	00000080	128	Motor Th Over (A11)	reserved	Motor Th Over (W11)	reserved	Output Current High current > 4-51	Control Ready
8	00000100	256	Motor ETR Over (A10)	reserved	Motor ETR Over (W10)	reserved	Output Current Low current < 4-50	Drive Ready
9	00000200	512	Inverter Overld. (A9)	Discharge High	Onverter Overld (W9)	Discharge High	Output Freq High speed > 4-53	Quick Stop
10	00000400	1024	DC under Volt (A8)	Start Failed	SC under Volt (W8)	Multi-motor underload	Output Freq Low speed < 4-52	DC Brake
11	00000800	2048	DC over Volt (A7)	Speed Limit	SC over Volt (W7)	Multi-motor Overload	Brake Check OK brake test NOT ok	Stop

Bit	Hex	Dec	Alarm word	Alarm word 2	Warning word	Warning word 2	Extended Status word	Extended Status word 2
Alarm Word Extended Status Word								
12	00001000	4096	Short Circuit (A16)	Pump Protect	DC Voltage Low (W6)	Compress or Interlock	Braking Max BrakePower > BrakePowerLimit (2-12)	Stand by
13	00002000	8192	Inrush Fault (A33)	Illegal Option Combi.	DC Voltage High (W5)	Mechanical Brake Sliding	Braking	Freeze Output Request
14	00004000	16384	Input Phase Loss (A4)	No Safety Option	Mains ph. Loss (W4)	Safe Option Warning	Out of Speed Range	Freeze Output
15	00008000	32768	AMA not OK	reserved	No Motor (W3)	Auto DC Braking	OVC Active	Jog Request
16	00010000	65536	Sensor Fault (A2)	reserved	Sensor Fault (W2)		AC Brake	Jog
17	00020000	131072	Internal Fault (A38)	KTY error	10V Low (W1)	KTY Warn	Password Timelock number of allowed password trials exceeded - timelock active	Start Request
18	00040000	262144	Brake Overload (A26)	Fans error	Brake Overload (W26)	Fans Warn	Password Protection 0-61 = ALL_NO_ACCESS OR BUS_NO_ACCESS OR BUS_READONLY	Start
19	00080000	524288	U phase Loss (A30)	ECB error	Brake Resistor (W25)	ECB Warn	Reference High reference > 4-55	Start Applied
20	00100000	1048576	V phase Loss (AA31)	reserved	Brake IGBT (W27)	reserved	Reference Low reference < 4-54	Start delay
21	00200000	2097152	W phase Loss (A32)	reserved	Speed Limit (W49)	RESERVED	Local Reference reference site = REMOTE > auto on pressed & active	Sleep
22	00400000	4194304	Fieldbus Fault (A34)	reserved	Fieldbus Fault (W34)	reserved	Protection mode notification	Sleep Boost
23	00800000	8388608	24 V Supply Low (A47)	reserved	24V Supply Low (W47)	reserved	Unused	Running
24	01000000	16777216	Mains Failure (A36)	reserved	Mains Failure (W36)	reserved	Unused	Drive Bypass
25	02000000	33554432	1.8V Supply Low (A48)	Current Limit (W59)	Current Limit (A59)	reserved	Unused	Fire Mode

Bit	Hex	Dec	Alarm word	Alarm word 2	Warning word	Warning word 2	Extended Status word	Extended Status word 2
Alarm Word Extended Status Word								
26	04000000	67108864	Brake Resistor (A25)	reserved	Low Temp (W66)	reserved	Unused	Pump Protect
27	08000000	134217728	Brake IGBT (A27)	reserved	Voltage Limit (W64)	reserved	Unused	Firemode Limit Exceed
28	10000000	268435456	Option Change (A67)	reserved	Encoder loss (W90)	reserved	Unused	FlyStart active
29	20000000	536870912	Drive Initialized (A80)	Encoder loss (A90)	Output freq. lim. (W62)	BackEMF too High	Unused	
30	40000000	1073741824	Safe Stop (A68)	PTC Thermistor (A74)	Safe Stop (W68)	PTC Thermistor (W74)	Unused	
31	80000000	2147483648	Mech. brake low (A63)	Dangerous failure (A72)	Extended Status Word		Protection Mode	

The alarm words, warning words and extended status words can be read out via serial bus or optional fieldbus for diagnostics, or through 16–94 Ext. Status Word.

7.4 Warnings and alarms

Warning/Alarm	Description	Cause	Remedy
1 – 10 V low	The control card voltage is below 10 V from terminal 50.	A short in a connected potentiometer or improper wiring of the potentiometer.	Remove the wiring from terminal 50. If the warning clears, the problem is with the customer wiring.
2 – Sensor Fault	This warning or alarm will only appear if programmed by the user in 6–01 Sensor FaultTimeout Function. The signal on one of the analog inputs is less than 50% of the minimum value that is programmed for that input.	Broken wiring or faulty device sending the signal.	Check the connections on all the analog input terminals. Control card terminals 53 and 54 for signals, terminal 55 common. General Purpose I/O Option Card terminals 11 and 12 for signals, terminal 10 common. Analog I/O Option Card terminals 1, 3, 5 for signals, terminals 2, 4, 6 common. Check that the frequency converter programming and switch settings match the analog signal type. Perform Input Terminal Signal Test
4 – Input phase loss	A phase is missing on the supply side, or the mains voltage imbalance is too high. This message also appears for a fault in the input rectifier on the frequency converter. Options are programmed at [14–12] Function at Input Imbalance (not applicable for single-phase drives).		Check the supply voltage and supply currents to the frequency converter.
5 – DC link voltage high	The intermediate circuit voltage (DC) is higher than the high voltage warning limit.	The limit is dependent on the frequency converter voltage rating. The frequency converter is still active.	

Warning/Alarm	Description	Cause	Remedy
6 – DC link voltage low	The intermediate circuit voltage (DC) is lower than the low voltage warning limit.	The limit is dependent on the frequency converter voltage rating. The frequency converter is still active.	
7 – DC overvoltage	If the intermediate circuit voltage exceeds the limit, the frequency converter trips after a time.		Connect a brake resistor Extend a ramp time Change the ramp type Activate functions in [2–10] Brake Function Increase [14–26] Trip Delay at Inverter Fault
8 – DC under voltage	If the intermediate circuit voltage (DC) drops below the under voltage limit, the frequency converter checks if a 24 VDC backup supply is connected.	If no 24 VDC backup supply is connected, the frequency converter trips after a fixed time delay. The time delay varies with unit size.	Check that the supply voltage matches the frequency converter voltage. Perform input voltage test Perform soft charge and rectifier circuit test.
9 – Inverter overloaded	The frequency converter is about to cut-out because of an overload (too high current for too long). The counter for electronic, thermal inverter protection gives a warning at 98% and trips at 100% while giving an alarm. The frequency converter cannot be reset until the counter is below 90%.	The fault is that the frequency converter is overloaded by more than 100% for too long.	Compare the output current shown on the LCP with the frequency converter rated current. Compare the output current shown on the LCP with the measured motor current. Display the Thermal Drive Load on the LCP and
10 – Motor overload temperature	According to the electronic thermal protection (ETR), the motor is too hot. Select whether the frequency converter gives a warning or an alarm when the counter reaches 100% in 1–90 Motor Thermal Protection.	The fault occurs when the motor is overloaded by more than 100% for too long.	Check for motor overheating. Check if the motor is mechanically overloaded. Check that the motor current set in [1–24] Motor Current is correct.
11 – Motor thermistor over temp	The thermistor might be disconnected. Select whether the frequency converter gives a warning or an alarm in 1–90 Motor Thermal Protection.		Check for motor overheating. Check if the motor is mechanically overloaded. When using terminal 53 or 54, check that the thermistor is connected correctly between either terminal 53 or 54 (analog voltage input) and terminal 50 (+10 V supply) and that the terminal switch for 53 or 54 is set for voltage. Check [1–93] Thermistor Source selects terminal 53 or 54. When using digital inputs 18 or 19, check that the thermistor is connected correctly between either terminal 18 or 19 (digital input PNP only) and terminal 50. Check [1–93] Thermistor Source selects terminal 18 or 19.

Warning/Alarm	Description	Cause	Remedy
12 – Torque limit	The torque has exceeded the value in 4-16 Torque Limit Motor Mode or the value in 4-17 Torque Limit Generator Mode. 14-25 Trip Delay at Torque Limit can change this from a warning only condition to a warning followed by an alarm.		<p>If the motor torque limit is exceeded during ramp up, extend the ramp up time.</p> <p>If the generator torque limit is exceeded during ramp down, extend the ramp down time.</p> <p>If torque limit occurs while running, possibly increase the torque limit. Be sure the system can operate safely at a higher torque.</p> <p>Check the application for excessive current draw on the motor.</p>
13 – Over current	The inverter peak current limit (approx. 200% of the rated current) is exceeded. The warning lasts about 1.5 seconds, then the frequency converter trips and issues an alarm. This fault may be caused by shock loading or fast acceleration with high inertia loads. If extended mechanical brake control is selected, trip can be reset externally.		<p>Remove power and check if the motor can be turned.</p> <p>Check that the motor size matches the frequency converter.</p> <p>Check parameters 1-20 through 1-25 for correct motor data.</p>
14 – Ground/Earth fault	There is current from the output phases to ground, either in the cable between the frequency converter and the motor or in the motor itself.		<p>Remove power to the frequency converter and repair the earth fault.</p> <p>Check for ground faults in the motor by measuring the resistance to ground of the motor leads and the motor megohmmeter.</p>
15 – Hardware mismatch	A fitted option is not operational with the present control board hardware or software.		<p>Record the value of the following parameters and contact your Xylem supplier:</p> <ul style="list-style-type: none"> • [15-40] FC Type • [15-41] Power Section • [15-42] Voltage • [15-43] Software Version • [15-45] Actual Typecode String • [15-49] SW ID Control Card • [15-50] SW ID Power Cord • [15-60] Option Mounted • [15-61] Option SW Version
16 – Short circuit	There is a short circuit in the motor or motor wiring.		<p>Remove power to the frequency converter and repair the short circuit.</p>
17 – Control word timeout	There is no communication to the frequency converter. The warning will only be active when [8-04] Control Timeout Function is NOT set to [0] OFF.	If [8-04] Control Timeout Function is set to Stop and Trip, a warning appears and the frequency converter ramps down until it stops then displays an alarm.	<p>Check connections on the series communication cable.</p> <p>Increase [8-03] Control Timeout Time</p> <p>Check operation of the communication equipment</p> <p>Verify proper installation based on EMC requirements.</p>

Warning/Alarm	Description	Cause	Remedy
18 – Start failed	The speed has not been able to exceed [1-77] Compressor Start Max Speed [RPM] during start within the allowed time. (set in [1-79] Compressor Start Max Time to Trip).	This may be caused by a blocked motor.	
23 – Internal fan fault	The fan warning function checks if the fan is running. The fan warning can be disabled on [14-53] Fan Monitor.		Check for proper fan operation. Cycle power to the frequency converter and check that the fan operates briefly at startup. Check the sensors on the heatsink and control card.
24 – External fan fault	The fan warning function checks if the fan is running. The fan warning can be disabled on [14-53] Fan Monitor.		Check for proper fan operation. Cycle power to the frequency converter and check that the fan operates briefly at startup. Check the sensors on the heatsink and control card.
25 – Brake resistor short circuit	The brake resistor is monitored during operation. If a short circuit occurs, the brake function is disabled and the warning appears. The frequency converter is still operational but without the brake function.		Remove power to the frequency converter and replace the brake resistor (see [2-15] Brake Check).
26 – Brake resistor power limit	The power transmitted to the brake resistor is calculated as a mean value over the last 120 seconds of run time. The calculation is based on the intermediate circuit voltage and the brake resistance value set in [2-16] brake Max. Current.	The warning is active when the dissipated braking is higher than 90% of the brake resistance power. If Trip [2] is selected in [2-13] Brake Power Monitoring, the frequency converter will trip when the dissipated braking power reaches 100%.	
27 – Brake chopper fault	The brake transistor is monitored during operation and if a short circuit occurs, the brake function is disabled and a warning is issued.	The frequency converter is still operational but, since the brake transistor has short-circuited, substantial power is transmitted to the brake resistor, even if it is inactive.	Remove power to the frequency converter and remove the brake resistor.
28 – Brake check failed	The brake resistor is not connected or not working.		Check [2-15] Brake Check.
29 – Heatsink temp	The maximum temperature of the heatsink has been exceeded. The temperature fault will not reset until the temperature falls below the reset heatsink temperature. The trip and reset points are based on the frequency converter power size.		Check for the following conditions: <ul style="list-style-type: none"> • Ambient temperature too high. • Motor cable too long. • Incorrect airflow clearance above and below the frequency converter. • Blocked airflow around the frequency converter. • Damaged heatsink fan. • Dirty heatsink.
30 – Motor phase U missing	Motor phase U between the frequency converter and the motor is missing.		Remove power from the frequency converter and check motor phase U.

Warning/Alarm	Description	Cause	Remedy
31 – Motor phase V missing	Motor phase V between the frequency converter and the motor is missing.		Remove power from the frequency converter and check motor phase V.
32 – Motor phase W missing	Motor phase W between the frequency converter and the motor is missing.		Remove power from the frequency converter and check motor phase W.
33 – Inrush fault	Too many power-ups have occurred within a short time period.		Let the unit cool to operating temperature.
34 – Fieldbus communication fault	Communication between the fieldbus and the communication option card is not operating.		
36 – Mains failure	This warning/alarm is only active if the supply voltage to the frequency converter is lost and 14-10 Mains Failure is NOT set to [0] No Function.		Check the fuses to the frequency converter and mains power supply to the unit.
38 – Internal fault	When an internal fault occurs, a code number defined in the table below is displayed.		Cycle power to the frequency converter. Check that the option is properly installed. Check for loose or missing wiring. It may be necessary to contact your Xylem supplier or service department. Note the code number for further troubleshooting directions.
39 – Heatsink sensor	No feedback from the heatsink temperature sensor.	The signal from the IGBT Thermal sensor is not available on the power card. The problem could be on the power card, on the gate drive card, or the ribbon cable between the power card and gate drive card.	
40 – Overload of digital output terminal 27			Check the load connected to terminal 27 or remove short-circuit connection. Check [5-00] Digital I/O Mode and 5-01 Terminal 27 Mode.
41 – Overload of digital output terminal 29			Check the load connected to terminal 29 or remove short-circuit connection. Check [5-00] Digital I/O Mode and [5-02] Terminal 29 Mode.
42 – Overload of digital output on X30/6 or overload of digital output on X30/7			For X30/6, check the load connected to X30/6 or remove short-circuit connection. Check 5-32 Term X30/6 Digi Out (General Purpose I/O Option Card). For X30/7, check the load connected to X30/7 or remove short-circuit connection. Check 5-33 Term X30/7 Digi Out (General Purpose I/O Option Card).

Warning/Alarm	Description	Cause	Remedy
45 – Ground fault 2	Ground (earth) fault on startup.		Check for proper grounding (earthing) and loose connections. Check for proper wire size. Check motor cables for short-circuits or leakage currents.
46 – Power card supply	The supply on the power card is out of range.	There are three power supplies generated by the switch mode power supply (SMPS) on the power card: 24 V, 5 V, +/- 18 V. When powered with 24 VDC with the 24VDC Backup Option Card option, only the 24 V and 5 V supplies are monitored. When powered with three-phase mains voltage, all three supplied are monitored.	Check for a defective power cord. Check for a defective control card. Check for a defective option card. If a 24 VDC power supply is used, verify proper supply power.
47 – 24 V supply low	The 24 V DC is measured on the control card.	The external 24 V DC backup power supply may be overloaded.	Contact your Xylem supplier.
48 – 1.8 V supply low	The power supply is measured on the control card.	The 1.8 V DC supply used on the control card is outside of allowable limits.	Check for a defective control card. If an option card is present, check for an overvoltage condition.
49 – Speed limit	When the speed is not within the specified range in [4-11] Motor Speed Low Limit [RPM] and [4-13] Motor Speed High Limit [RPM], the frequency converter will show a warning.	When the speed is below the specified limit in [1-86] Trip Speed Low [RPM] (except when starting or stopping) the frequency converter will trip.	
50 – AMA calibration failed			Contact your Xylem supplier or Xylem Service Department.
51 – AMA check Unom and Inom	The settings for motor voltage, motor current, and motor power are wrong.		Check the settings in parameters 1-20 to 1-25.
52 – AMA low Inom	The motor current is too low.		Check the setting in [4-18] Current Limit.
53 – AMA motor too big	The motor is too big for the AMA to operate.		
54 – AMA motor too small	The motor is too small for the AMA to operate.		
55 – AMA Parameter out of range	The parameter values of the motor are outside of the acceptable range. AMA will not run.		
56 – AMA interrupted by the user	The AMA has been interrupted by the user.		
57 – AMA timeout			Try to restart AMA again. Repeated restarts may overheat the motor.
58 – AMA internal fault			Contact your Xylem supplier.
59 – Current limit	The current is higher than the value in [4-18] Current Limit.		Ensure that motor data in parameters 1-20 through 1-25 are set correctly. Possibly increase the current limit. Be sure that the system can operate safely at a higher limit.

Warning/Alarm	Description	Cause	Remedy
60 – Pump Protect	A digital input signal is indicating a pump protection external to the controller is active.		
62 – Output frequency at maximum limit	The output frequency has reached the value set in [4–19] Max Output Frequency.		Check the application to determine the cause. Possibly increase the output frequency. Be sure the system can operate safely at a higher output frequency. The warning will clear when the output drops below the maximum limit.
65 – Control card over temperature	The cut-out temperature of the control card is 80°C.		Check that the ambient operating temperature is within limits. Check for clogged filters. Check fan operation. Check the control card.
66 – Heatsink temperature low	The frequency converter is too cold to operate. This warning is based on the temperature sensor in the IGBT module.		Increase the ambient temperature of the unit. A trickle amount of current can be supplied to the frequency controller whenever the motor is stopped by setting [2–00] DC Hold/Preheat Current at 5% and [1–80] Function at Stop.
67 – Option module configuration has changed	One or more options have either been added or removed since the last power down.		Check that the configuration change is intentional and reset the frequency controller.
68 – Safe stop activated	Loss of the 24 VDC signal on terminal 37 has caused the frequency controller to trip.		To resume normal operation, apply 24 VDC to terminal 37 and reset the frequency controller.
69 – Power card temperature	The temperature sensor on the power card is either too hot or too cold.		Check that the ambient operating temperature is within limits. Check for clogged filters. Check fan operation. Check the power card.
70 – Illegal FC configuration	The control card and power card are incompatible.		Contact your supplier with the typecode of the unit from the
80 – Drive initialized to default value	Parameter settings are initialized to default settings after a manual reset.		Reset the unit to clear the alarm.
92 – No flow	A no-flow condition has been detected in the system.	[22–23] No-Flow Function is set for alarm.	Troubleshoot the system and reset the frequency converter after the fault has been cleared.
93 – No Water/Loss of Prime	A low power condition in the system with the frequency converter operating at high speed may indicate the pump is out of water or has lost prime.	[22–26] No Water/Loss of Prime Function is set for alarm. The [22–39] No Water/Loss of Prime Limit is set too high.	Troubleshoot the system and reset the frequency converter after the fault has been cleared.
94 – Under Pressure	The system pressure is below the Under Pressure limit (Under Pressure Limit = Setpoint [22–25] Under Pressure Difference).	This may indicate leakage in the system. [22–50] Under Pressure Function is set for alarm.	Troubleshoot the system, and reset the frequency converter after the fault has been cleared.
95 – Broken belt	Torque is below the torque level set for no load, indicating a broken belt.	[22–60] Broken Belt Function is set for alarm.	Troubleshoot the system and reset the frequency converter after the fault has been cleared.

Warning/Alarm	Description	Cause	Remedy
96 – Start delayed	Motor start has been delayed due to short-cycle protection.	[22-76] Interval between Starts is enabled.	Troubleshoot the system and reset the frequency converter after the fault has been cleared.
97 – Stop delayed	Stopping the motor has been delayed due to short cycle protection.	[22-76] Interval between Starts is enabled.	Troubleshoot the system and reset the frequency converter after the fault has been cleared.
98 – Clock fault	Time is not set or the RTC clock has failed.		Reset the clock in [0-70] Date and Time.
200 – Fire mode		This indicates the frequency controller is operating in fire mode.	Cycle power to the unit to remove the warning. See the fire mode data in the alarm log on the controller.
201 – Fire mode was active	This indicates the frequency controller had entered fire mode.		Cycle power to the unit to remove the warning. See the fire mode data in the alarm log on the controller.
202 – Fire mode limits exceeded	While operating in fire mode one or more alarm conditions has been ignored which would normally trip the unit.	Operating in this condition voids unit warranty.	Cycle power to the unit to remove the warning. See the fire mode data in the alarm log on the controller.
203 – Missing motor	With a frequency converter operating multi-motors, an under-load condition was detected.	This could indicate a missing motor.	Inspect the system for proper operation.
204 – Locked rotor	With a frequency converter operating multi-motors, an overload condition was detected.	This could indicate a locked rotor.	Inspect the motor for proper operation.
250 – New spare part	A component in the frequency converter has been replaced.		Reset the frequency converter for normal operation.
251 – New typecode	A component in the frequency converter has been replaced and the typecode changed.		Reset the frequency converter for normal operation.

8 Troubleshooting

8.1 Start up and operation troubleshooting

Table 35: Troubleshooting

Symptom	Possible cause	Test	Solution
Display dark/No function	Missing or open fuses or circuit breaker tripped	See Pre-startup inspections table in this manual.	Check the input power source
	No power to the LCP	Check the LCP cable for proper connection or damage	Replace the faulty LCP or connection cable
	Shortcut on control voltage (terminal 12 or 50) or at control terminals	Check the 24 V control voltage supply for terminals 12/13 to 20-39 or 10 V supply for terminals 50 to 55	Wire the terminals properly
	Wrong LCP		Use only LCP #9K651.
	Wrong contrast setting		Press [status] + [▲]/[▼] to adjust the contrast
	Display (LCP) is defective	Test using a different LCP	Replace the faulty LCP or connection cable
	Internal voltage supply fault or SMPS is defective		Contact supplier
Intermittent display	Overloaded power supply (SMPS) due to improper control wiring or fault within the frequency converter	To rule out a problem in the control wiring, disconnect all control wiring by removing the terminal blocks.	If the display stays lit, then the problem is in the control wiring. Check the wiring for shorts or incorrect connections. If the display continues to cut out, follow the procedure for display dark.
Motor not running	Service switch open or missing motor connection	Check if the motor is connected and the connection is not interrupted (by a service switch or other device)	Connect the motor and check the service switch
	No mains power with 24 V DC option card	If the display is functioning but no output, check that mains power is applied to the frequency converter	Apply mains power to run the unit
	LCP Stop	Check if [Off] has been pressed	Press [Auto On] or [Hand On] (depending on operation mode) to run the motor
	Missing start signal (Standby)	Check 5-10 <i>Terminal 18 Digital Input</i> for correct setting for terminal 18 (use default setting)	Apply a valid start signal to start the motor
	Motor coast signal active (Coasting)	Check 5-12 <i>Coast inv.</i> for correct setting for terminal 27 (use default setting)	Apply 24 V on terminal 27 or program this terminal to No operation
	Wrong reference signal source	Check reference signals: Local, remote or bus reference? Preset reference active? Terminal connection correct? Scaling of terminals correct? Reference signal available?	Program correct settings. Check 3-13 <i>Reference Site</i> . Set preset reference active in parameter group 3-1* <i>References</i> . Check for correct wiring. Check scaling or terminals. Check reference signal.

Symptom	Possible cause	Test	Solution
Motor running in wrong direction	Motor rotation limit	Check that <i>4-10 Motor Speed Direction</i> is programmed correctly.	Program correct settings
	Active reverse signal	Check if a reversing command is programmed for the terminal in parameter group <i>5-1* Digital inputs</i> .	Deactivate reversing signal
	Wrong motor phase connection		
Motor is not reaching maximum speed	Frequency limits set wrong	Check output limits in <i>4-13 Motor Speed High Limit [RPM]</i> , <i>4-14 Motor Speed High Limit [Hz]</i> and <i>4-19 Max Output Frequency</i> .	Program correct limits
	Reference input signal not scaled correctly	Check references input signal scaling in <i>6-0* Analog I/O Mode</i> and parameter group <i>3-1* References</i> . Reference limits in parameter group <i>3-0* Reference Limit</i> .	Program correct settings
Motor speed unstable	Possible incorrect parameter settings	Check the settings of all motor parameters, including all motor compensation settings. For closed loop operation, check PID settings.	Check settings in parameter group <i>1-6* Analog I/O mode</i> . For closed loop operation, check settings in parameter group <i>20-0* Feedback</i> .
Motor runs rough	Possible over-magnetization	Check for incorrect motor settings in all parameters	Check motor settings in parameter groups <i>1-2* Motor Data</i> , <i>1-3* Adv Motor Data</i> , and <i>1-5* Load Indep. Setting</i> .
Motor will not brake	Possible incorrect settings in the brake parameters. Possible too short ramp down times	Check brake parameters. Check ramp time settings	Check parameter group <i>2-0* DC Brake</i> and <i>3-0* Reference Limits</i> .
Open power fuses or circuit breaker trip	Phase to phase short	Motor or panel has a short phase to phase. Check motor and panel phase for shorts	Eliminate any shorts detected
	Motor overload	Motor is overloaded for the application	Perform startup test and verify motor current is within specifications. If motor current is exceeding nameplate full load current, motor may run only with reduced load. Review the specifications for the application.
	Loose connections	perform pre-startup check for loose connections	Tighten loose connections
Input current imbalance greater than 3%	Problem with mains power (see Alarm 4 input phase loss description in the Warnings and Alarms table)	Rotate input power leads into the frequency converter one position A to B, B to C to A.	If imbalanced leg follows the wire, it is a power problem. Check mains power supply.
	Problem with the frequency converter	Rotate input power leads into the frequency converter one position: A to B, B to C, C to A	If imbalance leg stays on same input terminal, it is a problem with the unit. Contact the supplier.
Motor current imbalance greater than 3%	Problem with motor or motor wiring	Rotate output motor leads one position: U to V, V to W, W to U.	If imbalanced leg follows the wire, the problem is in the motor or motor wiring. Check motor and motor wiring.
	Problem with the frequency converters	Rotate output motor leads one position: U to V, V to W, W to U.	If imbalance leg stays on same output terminal, it is a problem with the unit. Contact the supplier.

Symptom	Possible cause	Test	Solution
Acoustic noise or vibration (for example, a pump impeller blade makes noise or vibrations at certain frequencies)	Resonances, for example, in the motor/pump system	Bypass critical frequencies by using parameters in parameter group 4-6* <i>Speed Bypass</i>	Check if noise and/or vibration have been reduced to an acceptable limit
		Turn off over-modulation in 14-03 <i>Overmodulation</i>	
		Change switching pattern and frequency in parameter group 14-0* <i>Inverter Switching</i>	
		Increase Resonance Dampening in 1-64 <i>Resonance Dampening</i>	

9 Technical Specification

9.1 Power-dependent specifications

Table 36: Line power supply 380–480 V AC – Three Phase – 150 to 350 HP

Frequency Converter Type Designation	1500	2000	2500	3000	3500
Typical shaft output at 400 V [kW]	110	132	160	200	250
Typical shaft output at 460 V [hp]	150	200	250	300	350
Enclosure IP21	D5	D5	D5	D7	D7
Enclosure IP54	D5	D5	D5	D7	D7
Enclosure IP20/IP00	D3/	D3/	D3/	D4/	D4/
Enclosure 3R	D1	D1	D1	D2	D2
Output current					
Continuous at 400 V [A]	212	260	315	395	480
Intermittent (60 sec overload) (at 400 V) [A]	233	286	347	435	528
Continuous (at 460/480 V) [A]	190	240	302	361	443
Intermittent (60 sec overload) (at 460/480 V) [A]	209	264	332	397	487
Continuous KVA (at 400 V) [KVA]	147	180	218	274	333
Continuous KVA (at 460 V) [KVA]	151	191	241	288	353
Maximum input current					
Continuous (at 400 V) [A]	204	251	304	381	463
Continuous (at 460/480V) [A]	183	231	291	348	427
Maximum cable size, line power motor, brake and load share [mm ² (AWG ²)]	2 x 70 (2 x 2/0)		2 x 150 2 x 300 mcm)		
Maximum external pre-fuses [A] ¹	300	350	400	500	630
Estimated power loss ⁵⁾ at rated maximum load [W] ⁴⁾ , 400 V	3234	3782	4213	5119	5893
Estimated power loss ⁵⁾ at rated maximum load [W] ⁴⁾ , 460 V	2947	3665	4063	4652	5634
Weight, enclosure IP21, IP54 [kg]	96	104	125	136	151
Weight, enclosure IP00 [kg]	82	91	112	123	138
Efficiency ⁴⁾	0.98				
Output frequency	0-800 Hz				
Heatsink Overtemp. trip	194°F (90°C)	230°F (110°C)			
Power card ambient trip	140°F (60°C)				

Table 37: Line power supply 380–480 V AC – Three Phase – 450 to 600 HP

Frequency Converter Type Designation	4500	5000	5500	6000
Typical shaft output at 400 V [kW]	315	355	400	450
Typical shaft output at 460 V [hp]	450	500	550	600
Enclosure IP21	D7	E1	E1	E1
Enclosure IP54	D7	E1	E1	E1
Enclosure IP20/IP00	D4/	/E2	/E2	/E2
Enclosure 3R	D2			
Output current				

Frequency Converter Type Designation	4500	5000	5500	6000
Continuous at 400 V [A]	600	658	745	800
Intermittent (60 sec overload) (at 400 V) [A]	660	724	820	880
Continuous (at 460/480 V) [A]	540	590	678	730
Intermittent (60 sec overload) (at 460/480 V) [A]	594	649	746	803
Continuous KVA (at 400 V) [KVA]	416	456	516	554
Continuous KVA (at 460 V) [KVA]	430	470	540	582
Maximum input current				
Continuous (at 400 V) [A]	590	647	733	787
Continuous (at 460/480V) [A]	531	580	667	718
Maximum cable size, line power motor, brake and load share [mm ² (AWG ²)]	4 x 240 (4 x 500 mcm)			
Maximum cable size, brake [mm ² (AWG ²)]	2 x 185 (2 x 350 mcm)			
Maximum external pre-fuses [A] ¹	700	900		
Estimated power loss ⁵⁾ at rated maximum load [W] ⁴⁾ , 400 V	6790	7701	8879	9670
Estimated power loss ⁵⁾ at rated maximum load [W] ⁴⁾ , 460 V	6082	6953	8089	8803
Weight, enclosure IP21, IP54 [kg]	263	270	272	313
Weight, enclosure IP00 [kg]	221	234	236	277
Efficiency ⁴⁾	0.98			
Output frequency	0-600 Hz			
Heatsink Overtemp. trip	230°F (110°C)			
Power card ambient trip	154.4°F (68°C)			

Table 38: Line power supply 525-690 V AC – Three Phase – 150 to 300 HP

Frequency Converter Type Designation	1500	2000	2500	3000
Typical shaft output at 550 V [kW]	110	132	160	200
Typical shaft output at 575 V [hp]	150	200	250	300
Typical shaft output at 690 V [kW]	132	160	200	250
Enclosure IP21	D5	D5	D7	D7
Enclosure IP54	D5	D5	D7	D7
Enclosure IP20/IP00	D3/	D3/	D4/	D4/
Enclosure 3R	D1	D1	D2	D2
Output current				
Continuous at 550 V [A]	162	201	253	303
Intermittent (60 sec overload) (at 550 V) [A]	178	221	278	333
Continuous (at 575/690 V) [A]	155	192	242	290
Intermittent (60 sec overload) (at 575/690 V) [A]	171	211	266	319
Continuous KVA (at 550 V) [KVA]	154	191	241	289
Continuous KVA (at 550 V) [KVA]	154	191	241	289
Continuous KVA (at 690 V) [KVA]	185	229	289	347
Maximum input current				
Continuous (at 550 V) [A]	158	198	245	299
Continuous (at 575 V) [A]	151	189	234	286
Continuous (at 690 V) [A]	155	197	240	296

Frequency Converter Type Designation	1500	2000	2500	3000
Maximum cable size, line power motor, brake and load share [mm ² (AWG ²)]	2 x 70 (2 x 2/0)		2 x 150 2 x 300 mcm)	
Maximum external pre-fuses [A] ¹	315	350	350	400
Estimated power loss ⁵ at rated maximum load [W] ⁴ , 600 V	2963	3430	4051	4867
Estimated power loss ⁵ at rated maximum load [W] ⁴ , 690 V	3430	3612	4292	5156
Weight, enclosure IP21, IP54 [kg]	96	104	125	136
Weight, enclosure IP00 [kg]	82	91	112	123
Efficiency ⁴	0.98			
Output frequency	0-600 Hz			
Heatsink Overtemp. trip	194°F (90°C)	230°F (110°C)		
Power card ambient trip	140°F (60°C)			

Table 39: Line power supply 525-690 V AC – Three Phase – 350 to 450 HP

Frequency Converter Type Designation	3500	4000	4500
Typical shaft output at 550 V [kW]	250	315	355
Typical shaft output at 575 V [hp]	350	400	450
Typical shaft output at 690 V [kW]	315	400	450
Enclosure IP21	D7	D7	E1
Enclosure IP54	D7	D7	E1
Enclosure IP20/IP00	D4/	D4/	/E2
Enclosure 3R	D2	D2	
Output current			
Continuous at 550 V [A]	360	418	470
Intermittent (60 sec overload) (at 550 V) [A]	396	460	517
Continuous (at 575/690 V) [A]	344	400	450
Intermittent (60 sec overload) (at 575/690 V) [A]	378	440	495
Continuous KVA (at 550 V) [KVA]	343	398	448
Continuous KVA (at 575 V) [KVA]	343	398	448
Continuous KVA (at 690 V) [KVA]	411	478	538
Maximum input current			
Continuous (at 550 V) [A]	355	408	453
Continuous (at 575 V) [A]	339	390	434
Continuous (at 690 V) [A]	352	400	434
Maximum cable size, line power, motor, and load share [mm ² (AWG ²)]	2 x 150 2 x 300 mcm)		4 x 240 (4 x 500 mcm)
Maximum cable size, brake [mm ² (AWG ²)]	2 x 150 (2 x 300 mcm)		2 x 185 (2 x 350 mcm)
Maximum external pre-fuses [A] ¹	500	550	700
Estimated power loss ⁵ at rated maximum load [W] ⁴ , 600 V	5493	5852	6132
Estimated power loss ⁵ at rated maximum load [W] ⁴ , 690 V	5821	6149	6440
Weight, enclosure IP21, IP54 [kg]	151	165	263
Weight, enclosure IP00 [kg]	138	151	221

Frequency Converter Type Designation	3500	4000	4500
Efficiency ⁴⁾	0.98		
Output frequency	0-600 Hz	0-500 Hz	
Heatsink Overtemp. trip	230°F (110°C)		
Power card ambient trip	140°F (60°C)		154.4°F (68°C)

Table 40: Line power supply 525-690 V AC – Three Phase – 500 to 600 HP

Frequency Converter Type Designation	5000	6000
Typical shaft output at 550 V [kW]	400	450
Typical shaft output at 575 V [hp]	500	600
Typical shaft output at 690 V [kW]	500	560
Enclosure IP21	E1	E1
Enclosure IP54	E1	E1
Enclosure IP20/IP00	/E2	/E2
Enclosure 3R		
Output current		
Continuous at 550 V [A]	523	596
Intermittent (60 sec overload) (at 550 V) [A]	575	656
Continuous (at 575/690 V) [A]	500	570
Intermittent (60 sec overload) (at 575/690 V) [A]	550	627
Continuous KVA (at 550 V) [KVA]	498	568
Continuous KVA (at 575 V) [KVA]	498	568
Continuous KVA (at 690 V) [KVA]	598	681
Maximum input current		
Continuous (at 550 V) [A]	504	574
Continuous (at 575 V) [A]	482	549
Continuous (at 690 V) [A]	482	549
Maximum cable size, line power, motor, and load share [mm ² (AWG ²)]	4 x 240 (4 x 500 mcm)	
Maximum cable size, brake [mm ² (AWG ²)]	2 x 185 (2 x 350 mcm)	
Maximum external pre-fuses [A] ¹	700	900
Estimated power loss ⁵⁾ at rated maximum load [W] ⁴⁾ , 600 V	6903	8343
Estimated power loss ⁵⁾ at rated maximum load [W] ⁴⁾ , 690 V	7249	8727
Weight, enclosure IP21, IP54 [kg]	263	272
Weight, enclosure IP00 [kg]	221	236
Efficiency ⁴⁾	0.98	
Output frequency	0-500 Hz	
Heatsink Overtemp. trip	230°F (110°C)	
Power card ambient trip	154.4°F (68°C)	

9.2 General technical data

Line powersupply

Supply terminals	L1, L2, L3
Supply voltage	380-480 V ±10%
Supply voltage	525-690 V ±10%

AC line voltage low/voltage drop-out: During low AC line drop-out, the adjustable frequency drive continues until the intermediate circuit voltage drops below the minimum stop level, which corresponds typically to 15% below the adjustable frequency drive's lowest rated supply voltage. Power-up and full torque cannot be expected at AC line voltage lower than 10% below the adjustable frequency drive's lowest rated supply voltage.

Supply frequency 50/60 Hz $\pm 5\%$

Maximum temporary imbalance between line phases	3.0% of rated supply voltage
True power factor (λ)	≥ 0.9 nominal rated load
Displacement Power Factor ($\cos \phi$) near unity	(> 0.98)
Switching on input supply L1, L2, L3 (power-ups)	maximum 1 time/minute
Environment according to EN60664-1	overvoltage category III/pollutin degree 2

The unit is suitable for use on a circuit capable of delivering not more than 100,000 RMS symmetrical Amperes, 480/600 V.

Motor output (U, V, W)

Output voltage	0-100% of supply voltage
Output frequency	0-590 ¹⁾ Hz
Switching on output	Unlimited
Ramp times	0.01-3,600 s

¹⁾ Voltage and power dependent

Torque characteristics

Starting torque (constant torque)	maximum 110% for 60 s ¹⁾
Starting torque	maximum 135% up to 0.5 s ¹⁾
Overload torque (constant torque)	maximum 110% for 60 s ¹⁾

¹⁾ Percentage relates to the adjustable frequency drive's nominal torque.

Cable lengths and cross sections for control cables¹⁾

Maximum motor cable length, shielded/armored	492 ft (150 m)
Maximum motor cable length, unshielded/unarmored	984 ft (300 m)
Maximum cross-section to motor line, load sharing and brake ¹⁾	
Maximum cross-section to control terminals, rigid wire	0.0023 in ² (1.5 mm ²)/16 AWG (2x0.75 mm ²)
Maximum cross-section to control terminals, flexible cable	0.0016 in ² (1 mm ²)/18 AWG
Maximum cross section to control terminals, cable with enclosed core	0.0008 in ² (0.5 mm ²)/20 AWG
Minimum cross-section to control terminals	0.00039 in ² (0.25 mm ²)

¹⁾ Depending on voltage and power.

Digital inputs

Programmable digital inputs	4 (6)
Terminal number	18, 19, 27 ¹⁾ , 29 ¹⁾ , 32, 33
Logic	PNP or NPN
Voltage level	0-24 V DC
Voltage level, logic '0' PNP	<5 V DC

Voltage level I, logic '1' PNP	>10 V DC
Voltage level, logic '0' NPN ²⁾	>19 V DC
Voltage level, logic '1' NPN ²⁾	<14 V DC
Maximum voltage on input	28 V DC
Input resistance, Ri	Approximately 4 k Ω

All digital inputs are galvanically isolated from the supply voltage (PELV) and other high-voltage terminals.

¹ Terminals 27 and 29 can also be programmed as output.

Analog inputs

Number of analog inputs	2
Terminal number	53, 54
Modes	Voltage or current
Mode select	Switches A53 and A54
Voltage mode	Switch A53/A54=(U)
Voltage level	0 V to 10 V (scaleable)
Input resistance Ri	Approximately 10 k Ω
Maximum voltage	\pm 20 V
Current mode	Switch A53/A54=(I)
Current level	0/4 to 20 mA (scaleable)
Input resistance Ri	Approximately 200 Ω
Maximum current	30 mA
Resolution for analog inputs	10 bit (+ sign)
Accuracy of analog inputs	Maximum error 0.5% of full scale
Bandwidth	100 Hz

The analog inputs are galvanically isolated from the supply voltage (PELV) and other high-voltage terminals.

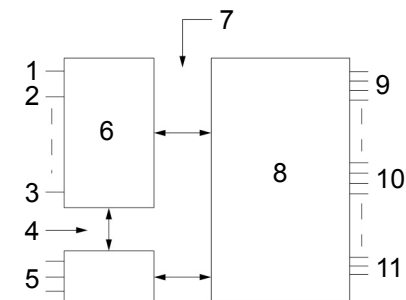

1. +24 V
2. 18
3. 37
4. Functional isolation
5. RS485
6. Control
7. PELV isolation
8. High voltage
9. Mains
10. Motor
11. DC-Bus

Figure 98: PELV isolation

Pulse inputs

Programmable pulse inputs	2
---------------------------	---

Terminal number pulse	29, 33
Maximum frequency at terminal 29, 33	110 kHz (push-pull driven)
Maximum frequency at terminal 29, 33	5 kHz (open collector)
Minimum frequency at terminal 29, 33	4 Hz
Voltage level	See Digital Inputs in the General Technical Data section.
Maximum voltage on input	28 V DC
Input resistance, Ri	Approximately 4k Ω
Pulse input accuracy (0.1-1 kHz)	Maximum error: 0.1% of full scale

Analog output

Number of programmable analog outputs	1
Terminal number	42
Current range at analog output	0/4-20 mA
Maximum resistor load to common at analog output	500 Ω
Accuracy on analog output	Maximum error: 0.8% of full scale
Resolution on analog output	8 bit

The analog output is galvanically isolated from the supply voltage (PELV) and other high-voltage terminals.

Control card, RS-485 serial communication

Terminal number	68 (P, TX+, RX+), 69 (N, TX-, RX-)
Terminal number 61	Common for terminals 68 and 69

The RS-485 serial communication circuit is functionally seated from other central circuits and galvanically isolated from the supply voltage (PELV).

Digital output

Programmable digital/pulse outputs	2
Terminal number	27, 29 ¹⁾
Voltage level at digital/frequency output	0-24 V
Maximum output current (sink or source)	40 mA
Maximum load at frequency output	1 k Ω
Maximum capacitive load at frequency output	10 nF
Minimum output frequency at frequency output	0 Hz
Maximum output frequency at frequency output	32 kHz
Accuracy of frequency output	Maximum error: 0.1% of full scale
Resolution of frequency outputs	12 bit

¹⁾ Terminal 27 and 29 can also be programmed as input.

The digital output is galvanically isolated from the supply voltage (PELV) and other high-voltage terminals.

Control card, 24 V DC output

Terminal number	12, 13
Maximum load	200 mA

The 24 V DC supply is galvanically isolated from the supply voltage (PELV), but has the same potential as the analog and digital inputs and outputs.

Relay outputs

Programmable relay outputs	2
Relay 01 terminal number	13 (break), 12 (make)
Maximum terminal load (AC-1) ¹⁾ on 12 (NO) (resistive load) ²⁾³⁾	400 V AC, 2 A
Maximum terminal load (AC-15) ¹⁾ on 1-2 (NO) (inductive load @ $\cos\phi$ 0.4)	240 V AC, 0.2 A
Maximum terminal load (DC-1) ¹⁾ on 12 (NO) (resistive load)	80 V DC, 2 A
Maximum terminal load (DC-13) ¹⁾ on 1-2 (NO) (inductive load)	24 V DC, 0.1 A
Maximum terminal load (AC-1) ¹⁾ on 13 (NC) (resistive load)	240 V AC, 2 A
Maximum terminal load (AC-15) ¹⁾ on 1-3 (NC) (inductive load @ $\cos\phi$ 0.4)	240 V AC, 0.2 A
Maximum terminal load (DC-1) ¹⁾ on 13 (NC) (resistive load)	50 V DC, 2 A
Maximum terminal load (DC-13) ¹⁾ on 1-3 (NC) (inductive load)	24 V DC, 0.1 A
Minimum terminal load on 1-3 (NC), 1-2 (NO)	24 V DC 10 mA, 24 V AC 2 mA
Environment according to EN 60664-1	overvoltage category III/pollution degree 2
Relay 02 (only) terminal number	4-6 (break), 4-5 (make)
Maximum terminal load (AC-1) ¹⁾ on 45 (NO) (resistive load)	400 V AC, 2 A
Maximum terminal load (AC-15) ¹⁾ on 45 (NO) (inductive load @ $\cos\phi$ 0.4)	240 V AC, 0.2 A
Maximum terminal load (DC-1) ¹⁾ on 45 (NO) (resistive load)	80 V DC, 2 A
Maximum terminal load (DC-13) ¹⁾ on 45 (NO) (inductive load)	24 V DC, 0.1 A
Maximum terminal load (AC-1) ¹⁾ on 46 (NC) (resistive load)	240 V AC, 2 A
Maximum terminal load (AC-15) ¹⁾ on 46 (NC) (inductive load @ $\cos\phi$ 0.4)	240 V AC, 0.2 A
Maximum terminal load (DC-1) ¹⁾ on 46 (NC) (resistive load)	50 V DC, 2 A
Maximum terminal load (DC-13) ¹⁾ on 46 (NC) (inductive load)	24 V DC, 0.1 A
Minimum terminal load on 46 (NC), 45 (NO)	24 V DC 10 mA, 24 V AC 20 mA
Environment according to EN 60664-1	overvoltage category III/pollution degree 2

¹⁾ IEC 60947 part 4 and 5

The relay contacts are galvanically isolated from the rest of the circuit by reinforced isolation (PELV).

²⁾ Overvoltage category II

³⁾ UL applications 300 V AC 2A

Control card, 10 V DC output

Terminal number	50
Output voltage	10.5 V \pm 0.5 V
Maximum load	15 mA

The 10 V DC supply is galvanically isolated from the supply voltage (PELV) and other high-voltage terminals.

Control characteristics

Resolution of output frequency at 0-1000 Hz	± 0.003 Hz
System response time (terminals 18, 19, 27, 29, 32, 33)	≤ 2 ms
Speed control range (open loop)	1:100 of synchronous speed
Speed accuracy (open loop)	30-4000 rpm: maximum error ±8 rpm

All control characteristics are based on a 4-pole asynchronous motor

Surroundings

Enclosure type D1h/D2h/D5h/D7h/E1/E2	IP21/Type 1, IP54/Type 12
Enclosure type D3h/D4h	IP20/Chassis
Enclosure type D1h and D2h	3R
Vibration test all enclosure types	1.0 g
Relative humidity	5% - 95% (IEC 72133; Class 3K3 (non-condensing) during operation)
Aggressive environment (IEC 60068243) H ₂ S test	class Kd
Test method according to IEC 60068-2-43 H ₂ S (10 days)	
Ambient temperature (at 60 AVM switching mode)	
- with derating	maximum 131°F (55°C) ¹⁾
- full output power of typical EFF2 motors (up to 90% output current)	maximum 122°F (50°C) ¹⁾
- at full continuous FC output current	maximum 113°F (45°C) ¹⁾
Minimum ambient temperature during full-scale operation	32°F (0°C)
Minimum ambient temperature at reduced performance	14°F (10°C)
Temperature during storage/transport	13°-149°/158°F (25 to +65°/70°C)
Maximum altitude above sea level without derating	3300 ft (1000 m)
Maximum altitude above sea level with derating	10,000 ft (3,000 m)
EMC standards, Emission	EN 61800-3, EN 61000-6-3/4, EN 55011, IEC 61800-3
EMC standards, immunity	EN 61800-3, EN 61000-6-1/2, EN 61000-4-2, EN 61000-4-3, EN 61000-4-4, EN 61000-4-5, EN 61000-4-6

Derating for high altitude, see the Technical Bulletin for detailed information.

¹⁾ For more information on derating see the Design Guide, section on Special Conditions.

Control card performance

Scan interval	5 ms
---------------	------

Control card, USB serial communication

USB standard	1.1 (full speed)
USB plug	USB type B "device" plug

Connection to PC is carried out via a standard host/device USB cable.

The USB connection is galvanically isolated from the supply voltage (PELV) and other high-voltage terminals.

The USB ground connection is not galvanically isolated from protection earth. Use only an isolated laptop as PC connection to the USB connector on the frequency converter.

Protection and features

- Electronic thermal motor protection against overload.
- Temperature monitoring of the heatsink ensures that the adjustable frequency drive trips if the temperature reaches 203°F ±10°F (95°C ±5° C). An overload temperature cannot be reset until the temperature of the heatsink is below 158°F ±9°F (70°C ±5°C) (Guideline – these temperatures may vary for different power sizes, frame sizes, enclosure, etc.)
- The adjustable frequency drive is protected against short-circuits on motor terminals U, V, W.
- If a line phase is missing, the adjustable frequency drive trips a warning (depending on the load).
- Monitoring of the intermediate circuit voltage ensures that the adjustable frequency drive trips if the intermediate circuit voltage is too low or too high.
- The adjustable frequency drive is protected against ground faults on moto terminals U, V, W.

9.3 Fuse tables

Non-UL compliance

If UL/cUL is not to be complied with, we recommend using the following fuses, which will ensure compliance with EN50178:

Table 41: Non-UL compliance, line fuses, 380-480 V

1500-3500	380-480 V	type gG
4000-6000	380-480 V	type gR

UL compliance

The fuses below are suitable for use on a circuit capable of delivering 100,000 Arms (symmetrical), 240 V, 480 V, 500 V, or 600 V depending on the drive voltage rating. With the proper fusing, the drive Short Circuit Current Rating (SCCR) is 100,000 Arms.

Table 42: Frame size D, line fuses, 380-480 V

Size/Type	Fuse options							
	Bussmann PN	Littelfuse PN	Littelfuse PN	Bussmann PN	SIBA PN	Ferraz- Shawmut PN	Ferraz- Shawmut PN (Europe)	Ferraz- Shawmut PN (North America)
1500	170M2619	LA50QS300-4	L50S-300	FWH-300A	20 610 31.315	A50QS300-4	6,9URD31D08 A0315	A070URD31KI 0315
2000	170M2620	LA50QS350-4	L50S-350	FWH-350A	20 610 31.350	A50QS350-4	6,9URD31D08 A0350	A070URD31KI 0350
2500	170M2621	LA50QS400-4	L50S-400	FWH-400A	20 610 31.400	A50QS400-4	6,9URD31D08 A0400	A070URD31KI 0400
3000	170M4015	LA50QS500-4	L50S-500	FWH-500A	20 610 31.550	A50QS500-4	6,9URD31D08 A0550	A070URD31KI 0550
3500	170M4016	LA50QS600-4	L50S-600	FWH-600A	20 610 31.630	A50QS600-4	6,9URD31D08 A0630	A070URD31KI 0630
4500	170M4017	LA50QS800-4	L50S-800	FWH-800A	20 610 31.800	A50QS800-4	6,9URD31D08 A0800	A070URD31KI 0800

Table 43: Frame size E, line fuses, 380–480 V

Size/Type	Bussmann PN*	Rating	Ferraz	Siba
5000	170M6013	900 A, 700 V	6.9URD33D08A0900	20 630 32.900
5500	170M6013	900 A, 700 V	6.9URD33D08A0900	20 630 32.900
6000	170M6013	900 A, 700 V	6.9URD33D08A0900	20 630 32.900

* 170M fuses from Bussmann shown use the /80 visual indicator; TN/80 Type T, /110 or TN/110 Type T indicator fuses of the same size and amperage may be substituted for external use.

** Any minimum 500 V UL listed fuse with associated current rating may be used to meet UL requirements.

Table 44: Frame size D, 525–690 V

OEM	Fuse options			
VLT model	Bussmann PN	SIBA PN	Ferraz-Shawmut European PN	Ferraz-Shawmut North American PN
1500	170M2619	20 610 31.315	6,9URD31D08A0315	A070URD31KI0315
2000	170M2619	20 610 31.315	6,9URD31D08A0315	A070URD31KI0315
2500	170M4015	20 620 31.550	6,9URD32D08A0550	A070URD32KI0550
3000	170M4015	20 620 31.550	6,9URD32D08A0550	A070URD32KI0550
3500	170M4015	20 620 31.550	6,9URD32D08A0550	A070URD32KI0550
4000	170M4015	20 620 31.550	6,9URD32D08A0550	A070URD32KI0550

Table 45: Frame size E, 525–690 V

Size/type	Bussmann PN*	Rating	Ferraz	Siba
4500	170M4017	700 A, 700 V	6.9URD31D08A0700	20 610 32.700
5000	170M4017	700 A, 700 V	6.9URD31D08A0700	20 610 32.700
6000	170M6013	900 A, 700 V	6.9URD31D08A0900	20 610 32.900

* 170M fuses from Bussmann shown use the /80 visual indicator; TN/80 Type T, /110 or TN/110 Type T indicator fuses of the same size and amperage may be substituted for external use.

Suitable for use on a circuit capable of delivering not more than 100,000 rms symmetrical amperes, 500/600/690 Volts maximum when protected by the above fuses.

Supplementary fuses

Table 46: SMPS fuse

D and E	KTK-4	4A, 600 V
Frame size	Bussmann*	Rating

Table 47: Fan fuses

4500–6000, 380–480 V		KLK-15	15A, 600 V
Size/Type	Bussmann*	LittelFuse	Rating
1500–4000, 380–480 V	KTK-4		4A, 600 V
1500–6000, 525–690 V	KTK-4		4A, 600 V

Line power disconnectors

Frame size	Power and voltage	Type
D1/D3	1500-1750 380-480 V & 1500-2000 525-690 V	ABB OETL-NF200A OR OT200U12-91
D2/D4	2000-3000 380-480 V AND 2500-5000 525-690 V	ABB OETL-NF400A OR OT400U12-91
E1/E2	4000 380-480 V AND 6000 525-690 V	ABB OETL-NF600A
E1/E2	4500-6000 380-480 V	ABB OETL-NF800A

NEC (NFPA 70) Compliance

Table 48: Line power supply 380-480 V AC – Three Phase – 150 to 600 HP

Frequency converter	HP rating	Continuous input current (3x380-480 V AC)	NEC fuse size (3x380-480 V AC)
1500	150	204/183	300-250
2000	200	251/231	350/300
2500	250	304/291	400
3000	300	381/348	500/450
3500	350	463/427	600
4500	450	590/531	800/700
5000	500	647/580	1000/800
5500	550	733/667	1000
6000	600	787/718	1000

Table 49: Line power supply 525-690 V AC – Three Phase – 150 to 650 HP

Frequency converter	HP rating	Continuous input current (3x550/575/690 V AC)	NEC fuse size (3x550/575/690 V AC)
1500	150	158/151/155	200
2000	200	198/189/197	250
2500	250	245/234/240	300
3000	300	299/286/296	400
3500	350	355/339/352	450
4000	400	408/390/400	600/500/600
4500	450	453/434/434	600
5000	500	504/482/482	700
6000	600	574/549/549	800/700/700

9.4 Wire sizing charts

VFD input wire sizing

Maximum allowable conductor length (45°C Ambient, 5% drop)																	
Line power supply	Controller ratings				Conductor size for 75°C rated wire (lengths in bold require 90°C rated wire)												
	Frequency converter	HP rating	Input current	Wires/phases	3	2	1	1/0	2/0	3/0	4/0	250	300	350	400	500	
3x460 VAC	1500	150	183	2		717	904	1141	1439								
	2000	250	291	2					905	1143	1439	1699	2040				
	2500	300	438	2							1204	1421	1706				
	3000	350	427	2								1158	1390				
	4000	450	531	4					992	1252	1577	1862	2236	2613	2988	3718	
	4500	500	580	4					908	1146	1444	1705	2047	2393	2736	3404	
	5000	550	667	4						997	1256	1483	1780	2080	2379	2960	
	6000	600	718	4							1167	1377	1654	1933	2210	2749	
3x575 VAC	2000	200	189	2		695	875	1104	1393								
	2500	250	234	2				892	1125	1421	1790	2113	2537				
	3000	300	286	2					921	1163	1464	1729	2076				
	3500	350	339	2							1235	1459	1751				
	4000	400	390	2								1268	1522				
	4500	450	434	4				962	1214	1532	1930	2279	2736	3197	3656	4549	
	5000	500	482	4				866	1093	1380	1738	2052	2463	2879	3292	4096	
	6000	600	549	4					959	1211	1526	1801	2163	2528	2890	3596	

VFD output wire sizing

Maximum allowable conductor length (45°C Ambient, 5% drop)																	
Line power supply	Controller ratings				Conductor size for 75°C rated wire (lengths in bold require 90°C rated wire)												
	Frequency converter	HP rating	Input current	Wires/phases	3	2	1	1/0	2/0	3/0	4/0	250	300	350	400	500	
3x460 VAC	1500	150	190	2		691	870	1099	1386								
	2000	200	240	2				870	1097								
	2500	250	302	2					872	1101	1387	1637	1966				
	3000	300	361	2							1160	1370	1644				
	3500	350	443	2								1116	1340				
	4500	450	540	4					975	1231	1551	1831	2199	2570	2939	3656	
	5000	500	590	4					893	1127	1420	1676	2012	2352	2690	3346	
	5500	550	678	4						981	1235	1459	1751	2047	2340	2912	
6000	600	730	4								1147	1355	1626	1901	2174	2704	

Maximum allowable conductor length (45°C Ambient, 5% drop)																
Line power supply	Controller ratings				Conductor size for 75°C rated wire (lengths in bold require 90°C rated wire)											
	Frequency converter	HP rating	Input current	Wires/phases	3	2	1	1/0	2/0	3/0	4/0	250	300	350	400	500
3x575 VAC	1500	150	155	2	670	847	1067	1347	1699							
	2000	200	192	2		684	861	1087	1372							
	2500	250	242	2				862	1088	1374	1731	2043	2453			
	3000	300	290	2					908	1146	1444	1705	2047			
	3500	350	344	2							1217	1437	1726			
	4000	400	400	2								1236	1484			
	4500	450	450	4				928	1170	1478	1861	2198	2638	3084	3526	4387
	5000	500	500	4				835	1053	1330	1675	1978	2374	2775	3174	3948
	6000	600	570	4					924	1167	1470	1735	2083	2434	2784	3463

The preceding tables show the maximum recommended cable lengths for each model, which is calculated based upon NEC recommended values and may be taken as a reference.

Cable lengths for each model listed is a single cable length with the numbers of wires in a phase considered, up to its corresponding Max AWG: 2x3/0, 2x350 or 4x500.

9.5 Parameter list

0-0*	Operation / Display	1-93	Thermistor Source	4-19	Max Output Frequency	5-68	Pulse Output Max Freq #X30/6
0-0*	Basic Settings	2-2*	Brakes	4-5*	Adj. Warnings	5-8*	I/O Options
0-01	Language	2-0*	DC-Brake	4-50	Warning Current Low	5-80	AHF Cap Reconnect Delay
0-02	Motor Speed Unit	2-00	DC Hold/Preheat Current	4-51	Warning Current High	5-9*	Bus Controlled
0-03	Regional Settings	2-01	DC Brake Current	4-52	Warning Speed Low	5-90	Digital & Relay Bus Control
0-04	Operating State at Power-up	2-02	DC Braking Time	4-53	Warning Speed High	5-93	Pulse Out #27 Bus Control
0-05	Local Mode Unit	2-03	DC Brake Cut In Speed [RPM]	4-54	Warning Reference Low	5-94	Pulse Out #27 Timeout Preset
0-0*	Set-up Operations	2-04	DC Brake Cut In Speed [Hz]	4-55	Warning Reference High	5-95	Pulse Out #29 Bus Control
0-1*	Active Set-up	2-06	Parking Current	4-56	Warning Feedback Low	5-96	Pulse Out #29 Timeout Preset
0-12	This Setup Linked to	2-07	Parking Time	4-57	Warning Feedback High	5-97	Pulse Out #X30/6 Bus Control
0-13	Readout: Linked Set-ups	2-1*	Brake Energy Funct.	4-58	Missing Motor Phase Function	5-98	Pulse Out #X30/6 Timeout Preset
0-14	Readout: Prog. Set-ups / Channel	2-10	Brake Function	4-6*	Speed Bypass	6-2*	Analog In/Out
0-2*	LCP Display	2-11	Brake Resistor (ohm)	4-60	Bypass Speed From [RPM]	6-0*	Analog I/O Mode
0-21	Display Line 1.1 Small	2-12	Brake Power Limit (kW)	4-61	Bypass Speed From [Hz]	6-00	Sensor Fault Timeout Time
0-20	Display Line 1.2 Small	2-13	Brake Power Monitoring	4-62	Bypass Speed To [RPM]	6-01	Sensor Fault Timeout Function
0-21	Display Line 1.2 Small	2-15	Brake Check	4-63	Bypass Speed To [Hz]	6-02	Fire Mode Sensor Fault Timeout Function
0-22	Display Line 1.3 Small	2-16	AC brake Max. Current	4-64	Semi-Auto Bypass Set-up	6-1*	Analog Input 53
0-23	Display Line 2 Large	2-17	Over-voltage Control	5-1*	Digital In/Out	6-10	Terminal 53 Low Voltage
0-24	Display Line 3 Large	3-0*	Reference / Ramps	5-00	Digital I/O mode	6-11	Terminal 53 High Voltage
0-25	My Personal Menu	3-0*	Reference Limits	5-00	Digital I/O Mode	6-12	Terminal 53 Low Current
0-3*	LCP Custom Readout	3-02	Minimum Reference	5-01	Terminal 27 Mode	6-13	Terminal 53 High Current
0-30	Custom Readout Unit	3-03	Maximum Reference	5-02	Terminal 29 Mode	6-14	Terminal 53 Low Ref./Feedb. Value
0-31	Custom Readout Min Value	3-04	Reference Function	5-10	Digital Inputs	6-15	Terminal 53 High Ref./Feedb. Value
0-32	Custom Readout Max Value	3-1*	References	5-11	Terminal 18 Digital Input	6-16	Terminal 53 High Ref./Feedb. Value
0-37	Display Text 1	3-10	Preset Reference	5-12	Terminal 19 Digital Input	6-17	Terminal 53 Filter Time Constant
0-38	Display Text 2	3-11	Jog Speed [Hz]	5-13	Terminal 27 Digital Input	6-2*	Analog Input 54
0-39	Display Text 3	3-13	Reference Site	5-13	Terminal 29 Digital Input	6-20	Terminal 54 Low Voltage
0-4*	LCP Keypad	3-14	Preset Relative Reference	5-14	Terminal 32 Digital Input	6-21	Terminal 54 High Voltage
0-40	[Hand on] Key on LCP	3-15	Reference 1 Source	5-15	Terminal 33 Digital Input	6-22	Terminal 54 Low Current
0-41	[Off] Key on LCP	3-16	Reference 2 Source	5-16	Terminal X30/2 Digital Input	6-23	Terminal 54 High Current
0-42	[Auto on] Key on LCP	3-17	Reference 3 Source	5-17	Terminal X30/3 Digital Input	6-24	Terminal 54 Low Ref./Feedb. Value
0-43	[Reset] Key on LCP	3-19	Jog Speed [RPM]	5-18	Terminal X30/4 Digital Input	6-25	Terminal 54 High Ref./Feedb. Value
0-44	[Off/Reset] Key on LCP	3-4*	Ramp 1	5-19	Terminal 37 Safe Stop	6-26	Terminal 54 Filter Time Constant
0-45	[Drive Bypass] Key on LCP	3-41	Ramp 1 Ramp Up Time	5-3*	Digital Outputs	6-27	Terminal 54 Sensor Fault
0-50	LCP Copy	3-42	Ramp 1 Ramp Down Time	5-30	Terminal 27 Digital Output	6-30	Analog Input X30/11
0-51	Set-up Copy	3-5*	Ramp 2 Ramp Up Time	5-31	Terminal 29 Digital Output	6-30	Terminal X30/11 Low Voltage
0-6*	Password	3-51	Ramp 2 Ramp Down Time	5-32	Term X30/6 Digi Out (MCB 101)	6-34	Terminal X30/11 High Voltage
0-60	Main Menu Password	3-52	Other Ramps	5-33	Term X30/7 Digi Out (MCB 101)	6-34	Term. X30/11 Low Ref./Feedb. Value
0-61	Access to Main Menu w/o Password	3-8*	Jog Ramp Time	5-41	On Delay, Relay	6-36	Term. X30/11 High Ref./Feedb. Value
0-65	Personal Menu Password	3-81	Quick Stop Ramp Time	5-42	Off Delay, Relay	6-37	Term. X30/11 Sensor Fault
0-66	Access to Personal Menu w/o Password	3-82	Starting Ramp Up Time	5-4*	Pulse Input	6-4*	Analog Input X30/12
0-67	Bus Access Password	3-9*	Digital Pot.Meter	5-50	Term. 29 Low Frequency	6-40	Terminal X30/12 Low Voltage
0-7*	Clock Settings	3-90	Step Size	5-50	Term. 29 High Frequency	6-41	Terminal X30/12 High Voltage
0-70	Date and Time	3-91	Ramp Time	5-51	Term. 29 Low Ref./Feedb. Value	6-44	Term. X30/12 Low Ref./Feedb. Value
0-71	Date Format	3-92	Power Restore	5-52	Term. 29 Low Ref./Feedb. Value	6-45	Term. X30/12 High Ref./Feedb. Value
0-72	Time Format	3-93	Maximum Limit	5-53	Term. 29 High Ref./Feedb. Value	6-46	Term. X30/12 Filter Time Constant
0-74	DST/Summertime	3-94	Minimum Limit	5-54	Pulse Filter Time Constant #29	6-47	Term. X30/12 Sensor Fault
0-76	DST/Summertime Start	3-95	Ramp Delay	5-56	Term. 33 Low Frequency	6-5*	Analog Output 42
0-77	DST/Summertime End	4-1*	Limits / Warnings	5-57	Term. 33 High Frequency	6-50	Terminal 42 Output
0-79	Clock Fault	4-1*	Motor Limits	5-58	Term. 33 High Ref./Feedb. Value	6-51	Terminal 42 Output Min Scale
0-81	Working Days	4-10	Motor Speed Direction	5-59	Term. 33 High Ref./Feedb. Value	6-52	Terminal 42 Output Max Scale
0-82	Additional Working Days	4-11	Motor Speed Low Limit [RPM]	5-60	Pulse Filter Time Constant #33	6-53	Terminal 42 Output Bus Control
0-83	Additional Non-Working Days	4-12	Motor Speed Low Limit [Hz]	5-60	Terminal 27 Pulse Output Variable	6-54	Terminal 42 Output Timeout Preset
0-89	Date and Time Readout	4-13	Motor Speed High Limit [RPM]	5-62	Pulse Output Max Freq #27	6-55	Analog Output Filter
1-*	Load and Motor	4-14	Motor Speed High Limit [Hz]	5-63	Terminal 29 Pulse Output Variable	6-6*	Analog Output X30/8
1-0*	General Settings	4-16	Torque Limit Motor Mode	5-63	Terminal 29 Pulse Output Variable	6-60	Terminal X30/8 Output
1-00	Configuration Mode	4-17	Torque Limit Generator Mode	5-65	Pulse Output Max Freq #29	6-61	Terminal X30/8 Min. Scale
		4-18	Current Limit	5-66	Terminal X30/6 Pulse Output Variable	6-62	Terminal X30/8 Max. Scale

6-63	Terminal X30/8 Output Bus Control	9-15	PCD Write Configuration	12-2*	Process Data	14-01	Switching Frequency	15-23	Historic log: Date and Time
6-64	Terminal X30/8 Output Timeout Preset	9-16	PCD Read Configuration	12-20	Control Instance	14-03	Overmodulation	15-3*	Alarm Log
8-0*	Common, and Options	9-18	Node Address	12-21	Process Data Config Write	14-04	PWM Random	15-30	Alarm Log: Error Code
8-01	Control Site	9-22	Telegram Selection	12-22	Process Data Config Read	14-1*	Mains On/Off	15-31	Alarm Log: Value
8-02	Control Source	9-23	Parameters for Signals	12-27	Primary Master	14-10	Mains Failure	15-32	Alarm Log: Time
8-03	Control Timeout	9-27	Parameter Edit	12-28	Store Data Values	14-11	Mains Voltage at Mains Fault	15-33	Alarm Log: Date and Time
8-04	Control Timeout Time	9-28	Process Control	12-29	Store Always	14-12	Function at Mains Imbalance	15-4*	Drive Identification
8-05	End-of-Timeout Function	9-44	Fault Message Counter	12-3*	EtherNet/IP	14-2*	Reset Functions	15-40	FC Type
8-06	End-of-Timeout Function	9-45	Fault Code	12-30	Warning Parameter	14-20	Reset Mode	15-41	Power Section
8-06	Reset Control Timeout	9-47	Fault Number	12-32	Net Reference	14-21	Automatic Restart Time	15-42	Voltage
8-07	Diagnosis Trigger	9-52	Fault Situation Counter	12-33	Net Control	14-22	Operation Mode	15-43	Software Version
8-08	Readout Filtering	9-53	Profibus Warning Word	12-33	CIP Revision	14-23	Typecode Setting	15-44	Ordered Typecode String
8-09	Communication Charset	9-63	Actual Baud Rate	12-34	CIP Product Code	14-25	Trip Delay at Torque Limit	15-45	Actual Typecode String
8-1*	Control Settings	9-64	Device Identification	12-35	EDS Parameter	14-26	Trip Delay at Inverter Fault	15-46	Frequency Converter Ordering No
8-10	Control Profile	9-65	Profile Number	12-37	COS Inhibit Timer	14-28	Production Settings	15-47	Power Card Ordering No
8-13	Configurable Status Word STW	9-67	Control Word 1	12-38	COS Filter	14-29	Service Code	15-48	LCP Id No
8-3*	FC Port Settings	9-68	Status Word 1	12-3*	Modbus TCP	14-3*	Current Limit Ctrl.	15-49	SW ID Control Card
8-30	Protocol	9-71	Profibus Save Data Values	12-40	Status Parameter	14-30	Current Lim Ctrl, Proportional Gain	15-50	SW ID Power Card
8-31	Address	9-72	ProfibusDriveReset	12-41	Slave Message Count	14-31	Current Lim Ctrl, Integration Time	15-51	Frequency Converter Serial Number
8-32	Baud Rate	9-75	DO Identification	12-42	Slave Exception Message Count	14-32	Current Lim Ctrl, Filter Time	15-53	Power Card Serial Number
8-33	Parity / Stop Bits	9-80	Defined Parameters (1)	12-8*	Other Ethernet Services	14-4*	Energy Optimising	15-55	Vendor URL
8-34	Estimated cycle time	9-81	Defined Parameters (2)	12-80	FTP Server	14-40	VT Level	15-56	Vendor Name
8-35	Minimum Response Delay	9-82	Defined Parameters (3)	12-81	HTTP Server	14-41	AEO Minimum Magnetisation	15-59	CSIV Filename
8-36	Maximum Response Delay	9-83	Defined Parameters (4)	12-82	SMTP Service	14-42	Minimum AEO Frequency	15-6*	Option Ident
8-37	Maximum Inter-Char Delay	9-84	Defined Parameters (5)	12-89	Transparent Socket Channel Port	14-43	Motor Cosphi	15-60	Option Mounted
8-4*	FC MC protocol set	9-90	Changed Parameters (1)	12-9*	Advanced Ethernet Services	14-5*	Environment	15-61	Option SW Version
8-40	Telegram Selection	9-91	Changed Parameters (2)	12-90	Cable Diagnostic	14-50	RFI Filter	15-62	Option Ordering No
8-42	PCD Write Configuration	9-92	Changed Parameters (3)	12-91	Auto Cross Over	14-51	DC Link Compensation	15-63	Option Serial No
8-43	PCD Read Configuration	9-93	Changed Parameters (4)	12-92	IGMP Snooping	14-52	Fan Control	15-70	Option in Slot A
8-5*	Digital/Bus	9-94	Changed Parameters (5)	12-93	Cable Error Length	14-53	Fan Monitor	15-71	Slot A Option SW Version
8-50	Coasting Select	9-99	Profibus Revision Counter	12-94	Broadcast Storm Protection	14-55	Output Filter	15-72	Option in Slot B
8-52	DC Brake Select	11-*	LonWorks	12-95	Broadcast Storm Filter	14-59	Actual Number of Inverter Units	15-73	Slot B Option SW Version
8-53	Start Select	11-0*	LonWorks ID	12-96	Port Config	14-6*	Auto Derate	15-8*	Operating Data II
8-54	Reversing Select	11-00	Neuron ID	12-98	Interface Counters	14-60	Function at Over Temperature	15-80	Fan Running Hours
8-55	Set-up Select	11-1*	Lon Functions	12-99	Media Counters	14-61	Function at Inverter Overload	15-81	Preset Fan Running Hours
8-56	Preset Reference Select	11-10	Drive Profile	13-*	Smart Logic	14-62	Inv. Overload Derate Current	15-9*	Parameter Info
8-7*	BACnet	11-15	LON Warning Word	13-0*	SLC Settings	14-9*	Fault Settings	15-92	Defined Parameters
8-70	BACnet Device Instance	11-17	XIF Revision	13-00	SL Controller Mode	14-90	Fault Level	15-93	Modified Parameters
8-72	MS/TP Max Masters	11-18	LonWorks Revision	13-01	Start Event	15-*	Drive Information	15-98	Drive Identification
8-73	MS/TP Max Info Frames	11-2*	LON Param. Access	13-02	Slop Event	15-0*	Operating Data	15-99	Parameter Metadata
8-74	"I,Am" Service	11-21	Store Data Values	13-03	Reset SLC	15-00	Operating hours	16-*	Data Readouts
8-75	Initialisation Password	12-*	Ethernet	13-1*	Comparators	15-01	Running Hours	16-0*	General Status
8-8*	FC Port Diagnostics	12-0*	IP Settings	13-10	Comparator Operand	15-02	kWh Counter	16-00	Control Word
8-80	Bus Message Count	12-00	IP Address Assignment	13-11	Comparator Operator	15-03	Power Up's	16-01	Reference [Unit]
8-81	Bus Error Count	12-01	IP Address	13-12	Comparator Value	15-04	Over Temp's	16-02	Reference [%]
8-82	Slave Messages Rcvd	12-02	Subnet Mask	13-2*	Timers	15-05	Over Volt's	16-03	Status Word
8-83	Slave Error Count	12-03	Default Gateway	13-20	SL Controller Timer	15-06	Reset kWh Counter	16-05	Main Actual Value [%]
8-84	Slave Messages Sent	12-04	DHCP Server	13-4*	Logic Rules	15-07	Reset Running Hours Counter	16-0*	Custom Readout
8-85	Slave Timeout Errors	12-05	Lease Expires	13-40	Logic Rule Boolean 1	15-08	Number of Starts	16-1*	Motor Status
8-89	Diagnostics Count	12-06	Name Servers	13-41	Logic Rule Operator 1	15-1*	Data Log Settings	16-10	Power [kW]
8-9*	Bus Jog / Feedback	12-07	Domain Name	13-42	Logic Rule Boolean 2	15-10	Logging Source	16-11	Power [hp]
8-90	Bus Jog 1 Speed	12-08	Host Name	13-43	Logic Rule Operator 2	15-11	Logging Interval	16-12	Motor Voltage
8-91	Bus Jog 2 Speed	12-09	Physical Address	13-44	Logic Rule Boolean 3	15-12	Trigger Event	16-13	Frequency
8-94	Bus Feedback 1	12-10	Link Status	13-5*	States	15-13	Logging Mode	16-14	Motor current
8-95	Bus Feedback 2	12-10	Link Duration	13-51	SL Controller Event	15-14	Samples Before Trigger	16-15	Frequency [%]
8-96	Bus Feedback 3	12-11	Link Negotiation	13-52	SL Controller Action	15-2*	Historic Log	16-16	Torque [Nm]
9-0*	Profibus	12-12	Auto Negotiation	14-*	Special Functions	15-20	Historic Log: Event	16-17	Speed [RPM]
9-00	Selfpoint	12-13	Link Speed	14-0*	Inverter Switching	15-21	Historic Log: Value	16-18	Motor Thermal
9-07	Actual Value	12-14	Link Duplex	14-00	Switching Pattern	15-22	Historic Log: Time	16-20	Motor Angle

16-22 Torque [%]	18-00 Maintenance Log: Item	20-79 PID Autotuning	21-57 Ext. 3 Reference [Unit]	22-84 Speed at No-Flow [Hz]
16-26 Power Filtered [kW]	18-01 Maintenance Log: Action	20-3* PID Basic Settings	21-58 Ext. 3 Feedback [Unit]	22-85 Speed at Design Point [RPM]
16-27 Power Filtered [hp]	18-02 Maintenance Log: Time	20-81 PID Normal/Inverse Control	21-59 Ext. 3 Output [%]	22-86 Speed at Design Point [Hz]
16-3* Drive Status	18-03 Maintenance Log: Date and Time	20-82 PID Start Speed [RPM]	21-6* Ext. CL 3 PID	22-87 Pressure at No-Flow Speed
16-30 DC Link Voltage	18-1* Fire Mode Log	20-83 PID Start Speed [Hz]	21-60 Ext. 3 Normal/Inverse Control	22-88 Pressure at Rated Speed
16-32 Brake Energy/2 min	18-10 Fire Mode Log: Event	20-84 On Reference Bandwidth	21-61 Ext. 3 Proportional Gain	22-89 Flow at Design Point
16-33 Brake Energy/2 min	18-11 Fire Mode Log: Time	20-3* PID Controller	21-62 Ext. 3 Integral Time	22-90 Flow at Rated Speed
16-34 Heatsink Temp.	18-12 Fire Mode Log: Date and Time	20-91 PID Anti Windup	21-63 Ext. 3 Differentiation Time	23-0* Time-based Functions
16-35 Inverter Thermal	18-3* Inputs & Outputs	20-93 PID Proportional Gain	21-64 Ext. 3 Dif. Gain Limit	23-00 ON Time
16-36 Inv. Nom. Current	18-30 Analog Input X42/1	20-94 PID Integral Time	22-0* Appl. Functions	23-01 ON Action
16-37 Inv. Max. Current	18-31 Analog Input X42/3	20-95 PID Differentiation Time	22-00 Pump Protect Delay	23-02 OFF Time
16-38 SL Controller State	18-32 Analog Input X42/5	21-0* Ext. Closed Loop	22-01 Power Filter Time	23-03 OFF Action
16-39 Control Card Temp.	18-33 Analog Out X42/7 [V]	21-0* Ext. CL Autotuning	22-2* No-Flow Detection	23-04 Occurrence
16-40 Logging Buffer Full	18-34 Analog Out X42/9 [V]	21-00 Closed Loop Type	22-20 Low Power Auto Set-up	23-0* Timed Actions Settings
16-41 Logging Buffer Full	18-35 Analog Out X42/11 [V]	21-01 PID Performance	22-21 Low Power Detection	23-08 Timed Actions Mode
16-43 Timed Actions Status	18-36 Analog Input X48/2 [mA]	21-02 PID Output Change	22-22 Low Speed Detection	23-09 Timed Actions Reactivation
16-49 Current Fault Source	18-37 Temp. Input X48/4	21-03 Minimum Feedback Level	22-23 No-Flow Function	23-1* Maintenance
16-5* Ref. & Feedb.	18-38 Temp. Input X48/7	21-04 Maximum Feedback Level	22-24 Sleep Delay	23-10 Maintenance Item
16-50 External Reference	18-39 Temp. Input X48/10	21-09 PID Autotuning	22-25 No Water/Loss of Prime Function	23-11 Maintenance Action
16-52 Feedback[Unit]	18-5* Ref. & Feedb.	21-1* Ext. CL 1 Ref./Fb.	22-26 No Water/Loss of Prime Delay	23-12 Maintenance Time Base
16-54 Feedback 1 [Unit]	18-50 Sensorless Readout [Unit]	21-10 Ext. 1 Ref./Feedback Unit	22-3* No-Flow Power Tuning	23-13 Maintenance Time Interval
16-55 Feedback 2 [Unit]	20-0* Feedback	21-11 Ext. 1 Minimum Reference	22-30 No-Flow Power	23-14 Maintenance Date and Time
16-56 Feedback 3 [Unit]	20-00 Feedback 1 Source	21-12 Ext. 1 Maximum Reference	22-31 Power Correction Factor	23-1* Maintenance Reset
16-6* Inputs & Outputs	20-01 Feedback 1 Conversion	21-13 Ext. 1 Reference Source	22-32 Sleep Frequency [RPM]	23-15 Reset Maintenance Word
16-60 Digital Input	20-02 Feedback 1 Source Unit	21-14 Ext. 1 Feedback Source	22-33 Sleep Frequency [Hz]	23-16 Maintenance Text
16-61 Terminal 53 Switch Setting	20-03 Feedback 2 Source	21-15 Ext. 1 Setpoint	22-34 Low Speed Power [kW]	23-5* Energy Log
16-62 Analog Input 53	20-04 Feedback 2 Conversion	21-17 Ext. 1 Reference [Unit]	22-35 Low Speed Power [HP]	23-50 Energy Log Resolution
16-63 Terminal 54 Switch Setting	20-05 Feedback 2 Source Unit	21-18 Ext. 1 Feedback [Unit]	22-36 High Speed [RPM]	23-51 Period Start
16-64 Analog Input 54	20-06 Feedback 3 Source	21-19 Ext. 1 Output [%]	22-37 High Speed [Hz]	23-53 Energy Log
16-65 Analog Output 42 [mA]	20-07 Feedback 3 Conversion	21-2* Ext. CL 1 PID	22-38 No Water/Loss of Prime Limit [kW]	23-54 Reset Energy Log
16-66 Digital Output [bin]	20-08 Feedback 3 Source Unit	21-20 Ext. 1 Normal/Inverse Control	22-39 No Water/Loss of Prime Limit [HP]	23-6* Trending
16-67 Pulse Input #29 [Hz]	20-09 Reference/Feedback Unit	21-21 Ext. 1 Proportional Gain	22-4* Sleep Mode	23-60 Trend Variable
16-68 Pulse Input #33 [Hz]	20-10 Minimum Reference/Feedb.	21-22 Ext. 1 Integral Time	22-40 Minimum Run Time	23-61 Continuous Bin Data
16-69 Pulse Output #27 [Hz]	20-11 Maximum Reference/Feedb.	21-23 Ext. 1 Differentiation Time	22-41 Minimum Sleep Time	23-62 Timed Bin Data
16-70 Pulse Output #29 [Hz]	20-2* Feedback/Setpoint	21-24 Ext. 1 Dif. Gain Limit	22-42 Wake-up Speed [RPM]	23-63 Timed Period Start
16-71 Relay Output [bin]	20-20 Feedback Function	21-3* Ext. CL 2 Ref./Fb.	22-43 Wake-up Speed [Hz]	23-64 Timed Period Stop
16-72 Counter A	20-21 Setpoint 1	21-30 Ext. 2 Ref./Feedback Unit	22-44 Restart Difference	23-65 Minimum Bin Value
16-73 Counter B	20-22 Setpoint 2	21-31 Ext. 2 Minimum Reference	22-45 Setpoint Boost	23-66 Reset Continuous Bin Data
16-75 Analog In X30/11	20-23 Setpoint 3	21-32 Ext. 2 Maximum Reference	22-5* Under Pressure	23-67 Reset Timed Bin Data
16-77 Analog Out X30/8 [mA]	20-3* Feedb. Adv. Conv.	21-33 Ext. 2 Reference Source	22-50 Under Pressure Function	23-8* Payback Counter
16-8* Fieldbus & FC Port	20-30 Refrigerant	21-34 Ext. 2 Feedback Source	22-51 Under Pressure Delay	23-80 Power Reference Factor
16-80 Fieldbus CTW 1	20-31 User Defined Refrigerant A1	21-35 Ext. 2 Setpoint	22-52 Under Pressure Difference	23-81 Energy Cost
16-82 Fieldbus REF 1	20-32 User Defined Refrigerant A2	21-37 Ext. 2 Reference [Unit]	22-6* Broken Belt Detection	23-82 Investment
16-84 Comm. Option STW	20-33 User Defined Refrigerant A3	21-38 Ext. 2 Feedback [Unit]	22-60 Broken Belt Function	23-83 Energy Savings
16-85 FC Port CTW 1	20-34 Duct 1 Area [m2]	21-39 Ext. 2 Output [%]	22-61 Broken Belt Torque	23-84 Cost Savings
16-86 FC Port REF 1	20-35 Duct 1 Area [m2]	21-4* Ext. CL 2 PID	22-62 Broken Belt Delay	24-0* Appl. Functions 2
16-9* Diagnosis Readouts	20-36 Duct 2 Area [m2]	21-40 Ext. 2 Normal/Inverse Control	22-7* Short Cycle Protection	24-00 Fire Mode
16-90 Alarm Word	20-37 Duct 2 Area [m2]	21-41 Ext. 2 Proportional Gain	22-75 Short Cycle Protection	24-01 Fire Mode Configuration
16-91 Alarm Word 2	20-38 Air Density Factor [%]	21-42 Ext. 2 Integral Time	22-76 Interval between Starts	24-02 Fire Mode Unit
16-92 Warning Word	20-6* Sensorless	21-43 Ext. 2 Differentiation Time	22-77 Minimum Run Time	24-03 Fire Mode Min Reference
16-93 Warning Word 2	20-60 Sensorless Unit	21-44 Ext. 2 Dif. Gain Limit	22-78 Minimum Run Time Override	24-04 Fire Mode Max Reference
16-94 Ext. Status Word	20-7* PID Autotuning	21-5* Ext. CL 3 Ref./Fb.	22-79 Minimum Run Time Override Value	24-05 Fire Mode Preset Reference
16-95 Ext. Status Word 2	20-70 Closed Loop Type	21-51 Ext. 3 Minimum Reference	22-8* Flow Compensation	24-06 Fire Mode Reference Source
16-96 Maintenance Word	20-71 PID Performance	21-52 Ext. 3 Maximum Reference	22-80 Flow Compensation	24-07 Fire Mode Feedback Source
18-0* Maintenance Log	20-72 PID Output Change	21-53 Ext. 3 Reference Source	22-81 Square-linear Curve Approximation	24-09 Fire Mode Alarm Handling
	20-73 Minimum Feedback Level	21-54 Ext. 3 Feedback Source	22-82 Work Point Calculation	24-1* Drive Bypass
	20-74 Maximum Feedback Level	21-55 Ext. 3 Setpoint	22-83 Speed at No-Flow [RPM]	24-10 Drive Bypass Function

24-11 Drive Bypass Delay Time	25-90 Pump Interlock	99-27 HS Temp. (PC8)
24-9** Multi-Motor Funct.	25-91 Manual Alternation	99-2* Platform Readouts
24-90 Missing Motor Function	26-0** Analog I/O Mode	99-29 Platform Version
24-91 Missing Motor Coefficient 1	26-00 Terminal X421/1 Mode	99-4* Software Control
24-92 Missing Motor Coefficient 2	26-01 Terminal X423 Mode	99-40 Startup/Wizard/State
24-93 Missing Motor Coefficient 3	26-02 Terminal X425 Mode	99-5* PC Debug
24-94 Missing Motor Coefficient 4	26-1* Analog Input X421/1	99-50 PC Debug Selection
24-95 Locked Rotor Function	26-10 Terminal X421/1 Low Voltage	99-51 PC Debug 0
24-96 Locked Rotor Coefficient 1	26-11 Terminal X421/1 High Voltage	99-52 PC Debug 1
24-97 Locked Rotor Coefficient 2	26-14 Term. X421/1 Low Ref./Feedb. Value	99-53 PC Debug 2
24-98 Locked Rotor Coefficient 3	26-15 Term. X421/1 High Ref./Feedb. Value	99-54 PC Debug 3
24-99 Locked Rotor Coefficient 4	26-16 Term. X421/1 Filter Time Constant	99-55 PC Debug 4
25-0** System Settings	26-17 Term. X421/1 Sensor Fault	99-56 Fan 1 Feedback
25-00 Constant Slave Controller	26-2* Analog Input X423	99-57 Fan 2 Feedback
25-02 Motor Start	26-20 Terminal X423 Low Voltage	99-58 PC Auxiliary Temp
25-04 Run Time Equalization	26-21 Terminal X423 High Voltage	99-9* Internal Values
25-05 Fixed Lead Pump	26-24 Term. X423 Low Ref./Feedb. Value	99-90 Options present
25-06 Number of Pumps	26-25 Term. X423 High Ref./Feedb. Value	99-91 Motor Power Internal
25-2* Bandwidth Settings	26-26 Term. X423 Filter Time Constant	99-92 Motor Voltage Internal
25-20 Staging Bandwidth	26-27 Term. X423 Sensor Fault	99-93 Motor Frequency Internal
25-21 Override Bandwidth	26-3* Analog Input X425	99-94 Imbalance derate [%]
25-22 Fixed Speed Bandwidth	26-30 Terminal X425 Low Voltage	99-95 Temperature derate [%]
25-23 SBW Staging Delay	26-31 Terminal X425 High Voltage	99-96 Overload derate [%]
25-24 SBW Deslaging Delay	26-34 Term. X425 Low Ref./Feedb. Value	
25-25 OBW Time	26-35 Term. X425 High Ref./Feedb. Value	
25-26 Deslague At No-Flow	26-36 Term. X425 Filter Time Constant	
25-27 Stage Function	26-37 Term. X425 Sensor Fault	
25-28 Stage Function Time	26-4* Analog Out X427	
25-29 Deslague Function	26-40 Terminal X427 Output	
25-30 Deslague Function Time	26-41 Terminal X427 Min. Scale	
25-4* Staging Settings	26-42 Terminal X427 Max. Scale	
25-40 Ramp Down Delay	26-43 Terminal X427 Bus Control	
25-41 Ramp Up Delay	26-44 Terminal X427 Timeout Preset	
25-42 Staging Threshold	26-5* Analog Out X429	
25-43 Staging Threshold	26-50 Terminal X429 Output	
25-44 Staging Speed [RPM]	26-51 Terminal X429 Min. Scale	
25-45 Staging Speed [Hz]	26-52 Terminal X429 Max. Scale	
25-46 Deslaging Speed [RPM]	26-53 Terminal X429 Bus Control	
25-47 Deslaging Speed [Hz]	26-54 Terminal X429 Timeout Preset	
25-5* Alternation Settings	26-6* Analog Out X421/1	
25-50 Lead Pump Alternation	26-60 Terminal X421/1 Output	
25-51 Alternation Event	26-61 Terminal X421/1 Min. Scale	
25-52 Alternation Time Interval	26-62 Terminal X421/1 Max. Scale	
25-53 Alternation Timer Value	26-63 Terminal X421/1 Bus Control	
25-54 Alternation Predefined Time	26-64 Terminal X421/1 Timeout Preset	
25-55 Alternate if Load < 50%	30-** Special Features	
25-56 Staging Mode at Alternation	30-2* Adv. Start Adjust	
25-58 Run Next Pump Delay	30-22 Locked Rotor Detection	
25-59 Run on Mains Delay	30-23 Locked Rotor Detection Time [s]	
25-8* Status	31-** Bypass Option	
25-80 Constant Slave Status	31-00 Bypass Mode	
25-81 Pump Status	31-01 Bypass Start Time Delay	
25-82 Lead Pump	31-02 Bypass Trip Time Delay	
25-83 Relay Status	31-03 Test Mode Activation	
25-84 Pump ON Time	31-10 Bypass Status Word	
25-85 Relay ON Time	31-11 Bypass Running Hours	
25-86 Reset Relay Counters	31-19 Remote Bypass Activation	
25-9* Service	35-** Sensor Input Option	
	35-00 Term. X48/4 Temperature Unit	
	35-01 Term. X48/4 Input Type	
	35-02 Term. X48/7 Temperature Unit	
	35-03 Term. X48/7 Input Type	
	35-04 Term. X48/10 Temperature Unit	
	35-05 Term. X48/10 Input Type	
	35-06 Temperature Sensor Alarm Function	
	35-1* Temp. Input X48/4	
	35-14 Term. X48/4 Filter Time Constant	
	35-15 Term. X48/4 Temp. Monitor	
	35-16 Term. X48/4 Low Temp. Limit	
	35-17 Term. X48/4 High Temp. Limit	
	35-2* Temp. Input X48/7	
	35-24 Term. X48/7 Filter Time Constant	
	35-25 Term. X48/7 Temp. Monitor	
	35-26 Term. X48/7 Low Temp. Limit	
	35-27 Term. X48/7 High Temp. Limit	
	35-3* Temp. Input X48/10	
	35-34 Term. X48/10 Filter Time Constant	
	35-35 Term. X48/10 Temp. Monitor	
	35-36 Term. X48/10 Low Temp. Limit	
	35-37 Term. X48/10 High Temp. Limit	
	35-4* Analog Input X48/2	
	35-42 Term. X48/2 Low Current	
	35-43 Term. X48/2 High Current	
	35-44 Term. X48/2 Low Ref./Feedb. Value	
	35-45 Term. X48/2 High Ref./Feedb. Value	
	35-46 Term. X48/2 Filter Time Constant	
	35-47 Term. X48/2 Sensor Fault	
	99-* Devel support	
	99-0* DSP Debug	
	99-00 DAC 1 selection	
	99-01 DAC 2 selection	
	99-02 DAC 3 selection	
	99-03 DAC 4 selection	
	99-04 DAC 1 scale	
	99-05 DAC 2 scale	
	99-06 DAC 3 scale	
	99-07 DAC 4 scale	
	99-08 Test param 1	
	99-09 Test param 2	
	99-10 DAC Option Slot	
	99-1* Hardware Control	
	99-11 RFI 2	
	99-12 Fan	
	99-1* Software Readouts	
	99-13 Idle time	
	99-14 Paramdb requests in queue	
	99-15 Secondary Timer at Inverter Fault	
	99-16 No of Current Sensors	
	99-2* Heatsink Readouts	
	99-20 HS Temp. (PC1)	
	99-21 HS Temp. (PC2)	
	99-22 HS Temp. (PC3)	
	99-23 HS Temp. (PC4)	
	99-24 HS Temp. (PC5)	
	99-25 HS Temp. (PC6)	
	99-26 HS Temp. (PC7)	

10 Product warranty

Commercial warranty

Warranty. For goods sold to commercial buyers, Seller warrants the goods sold to Buyer hereunder (with the exception of membranes, seals, gaskets, elastomer materials, coatings and other "wear parts" or consumables all of which are not warranted except as otherwise provided in the quotation or sales form) will be (i) be built in accordance with the specifications referred to in the quotation or sales form, if such specifications are expressly made a part of this Agreement, and (ii) free from defects in material and workmanship for a period of twenty-four (24) months from the date of installation or thirty (30) months from the date of shipment (which date of shipment shall not be greater than thirty (30) days after receipt of notice that the goods are ready to ship), whichever shall occur first, unless a longer period is specified in the product documentation (the "Warranty").

Except as otherwise required by law, Seller shall, at its option and at no cost to Buyer, either repair or replace any product which fails to conform with the Warranty provided Buyer gives written notice to Seller of any defects in material or workmanship within ten (10) days of the date when any defects or non-conformance are first manifest. Under either repair or replacement option, Seller shall not be obligated to remove or pay for the removal of the defective product or install or pay for the installation of the replaced or repaired product and Buyer shall be responsible for all other costs, including, but not limited to, service costs, shipping fees and expenses. Seller shall have sole discretion as to the method or means of repair or replacement. Buyer's failure to comply with Seller's repair or replacement directions shall terminate Seller's obligations under this Warranty and render the Warranty void. Any parts repaired or replaced under the Warranty are warranted only for the balance of the warranty period on the parts that were repaired or replaced. Seller shall have no warranty obligations to Buyer with respect to any product or parts of a product that have been: (a) repaired by third parties other than Seller or without Seller's written approval; (b) subject to misuse, misapplication, neglect, alteration, accident, or physical damage; (c) used in a manner contrary to Seller's instructions for installation, operation and maintenance; (d) damaged from ordinary wear and tear, corrosion, or chemical attack; (e) damaged due to abnormal conditions, vibration, failure to properly prime, or operation without flow; (f) damaged due to a defective power supply or improper electrical protection; or (g) damaged resulting from the use of accessory equipment not sold or approved by Seller. In any case of products not manufactured by Seller, there is no warranty from Seller; however, Seller will extend to Buyer any warranty received from Seller's supplier of such products.

THE FOREGOING WARRANTY IS EXCLUSIVE AND IN LIEU OF ANY AND ALL OTHER EXPRESS OR IMPLIED WARRANTIES, GUARANTEES, CONDITIONS OR TERMS OF WHATEVER NATURE RELATING TO THE GOODS PROVIDED HEREUNDER, INCLUDING WITHOUT LIMITATION ANY IMPLIED WARRANTIES OF MERCHANTABILITY AND FITNESS FOR A PARTICULAR PURPOSE, WHICH ARE HEREBY EXPRESSLY DISCLAIMED AND EXCLUDED. EXCEPT AS OTHERWISE REQUIRED BY LAW, BUYER'S EXCLUSIVE REMEDY AND SELLER'S AGGREGATE LIABILITY FOR BREACH OF ANY OF THE FOREGOING WARRANTIES ARE LIMITED TO REPAIRING OR REPLACING THE PRODUCT AND SHALL IN ALL CASES BE LIMITED TO THE AMOUNT PAID BY THE BUYER FOR THE DEFECTIVE PRODUCT. IN NO EVENT SHALL SELLER BE LIABLE FOR ANY OTHER FORM OF DAMAGES, WHETHER DIRECT, INDIRECT, LIQUIDATED, INCIDENTAL, CONSEQUENTIAL, PUNITIVE, EXEMPLARY OR SPECIAL DAMAGES, INCLUDING BUT NOT LIMITED TO LOSS OF PROFIT, LOSS OF ANTICIPATED SAVINGS OR REVENUE, LOSS OF INCOME, LOSS OF BUSINESS, LOSS OF PRODUCTION, LOSS OF OPPORTUNITY OR LOSS OF REPUTATION.

Limited consumer warranty

Warranty. For goods sold for personal, family or household purposes, Seller warrants the goods purchased hereunder (with the exception of membranes, seals, gaskets, elastomer materials, coatings and other "wear parts" or consumables all of which are not warranted except as otherwise provided in the quotation or sales form) will be free from defects in material and workmanship for a period of twenty-four (24) months from the date of installation or thirty (30) months from the product date code, whichever shall occur first, unless a longer period is provided by law or is specified in the product documentation (the "Warranty").

Except as otherwise required by law, Seller shall, at its option and at no cost to Buyer, either repair or replace any product which fails to conform with the Warranty provided Buyer gives written notice to Seller of any defects in material or workmanship within ten (10) days of the date when any defects or non-conformance are first manifest. Under either repair or replacement option, Seller shall not be obligated to remove or pay for the removal of the defective product or install or pay for the installation of the replaced or repaired product and Buyer shall be responsible for all other costs, including, but not limited to, service costs, shipping fees and expenses. Seller shall have sole discretion as to the method or means of repair or replacement. Buyer's failure to comply with Seller's repair or replacement directions shall terminate Seller's obligations under this Warranty and render this Warranty void. Any parts repaired or replaced under the Warranty are warranted only for the balance of the warranty period on the parts that were repaired or replaced. The Warranty is conditioned on Buyer giving written notice to Seller of any defects in material or workmanship of warranted goods within ten (10) days of the date when any defects are first manifest.

Seller shall have no warranty obligations to Buyer with respect to any product or parts of a product that have been: (a) repaired by third parties other than Seller or without Seller's written approval; (b) subject to misuse, misapplication, neglect, alteration, accident, or physical damage; (c) used in a manner contrary to Seller's instructions for installation, operation and maintenance; (d) damaged from ordinary wear and tear, corrosion, or chemical attack; (e) damaged due to abnormal conditions, vibration, failure to properly prime, or operation without flow; (f) damaged due to a defective power supply or improper electrical protection; or (g) damaged resulting from the use of accessory equipment not sold or approved by Seller. In any case of products not manufactured by Seller, there is no warranty from Seller; however, Seller will extend to Buyer any warranty received from Seller's supplier of such products.

THE FOREGOING WARRANTY IS PROVIDED IN PLACE OF ALL OTHER EXPRESS WARRANTIES. ALL IMPLIED WARRANTIES, INCLUDING BUT NOT LIMITED TO THE IMPLIED WARRANTIES OF MERCHANTABILITY AND FITNESS FOR A PARTICULAR PURPOSE, ARE LIMITED TO TWENTY-FOUR (24) MONTHS FROM THE DATE OF INSTALLATION OR THIRTY (30) MONTHS FROM THE PRODUCT DATE CODE, WHICHEVER SHALL OCCUR FIRST. EXCEPT AS OTHERWISE REQUIRED BY LAW, BUYER'S EXCLUSIVE REMEDY AND SELLER'S AGGREGATE LIABILITY FOR BREACH OF ANY OF THE FOREGOING WARRANTIES ARE LIMITED TO REPAIRING OR REPLACING THE PRODUCT AND SHALL IN ALL CASES BE LIMITED TO THE AMOUNT PAID BY THE BUYER FOR THE DEFECTIVE PRODUCT. IN NO EVENT SHALL SELLER BE LIABLE FOR ANY OTHER FORM OF DAMAGES, WHETHER DIRECT, INDIRECT, LIQUIDATED, INCIDENTAL, CONSEQUENTIAL, PUNITIVE, EXEMPLARY OR SPECIAL DAMAGES, INCLUDING BUT NOT LIMITED TO LOSS OF PROFIT, LOSS OF ANTICIPATED SAVINGS OR REVENUE, LOSS OF INCOME, LOSS OF BUSINESS, LOSS OF PRODUCTION, LOSS OF OPPORTUNITY OR LOSS OF REPUTATION.

Some states do not allow limitations on how long an implied warranty lasts, so the above limitation may not apply to you. Some states do not allow the exclusion or limitation of incidental or consequential damages, so the above exclusions may not apply to you. This warranty gives you specific legal rights, and you may also have other rights which may vary from state to state.

To make a warranty claim, check first with the dealer from whom you purchased the product or visit www.xylem.com for the name and location of the nearest dealer providing warranty service.

Xylem |'zīləm|

- 1) The tissue in plants that brings water upward from the roots
- 2) A leading global water technology company

We're a global team unified in a common purpose: creating innovative solutions to meet our world's water needs. Developing new technologies that will improve the way water is used, conserved, and re-used in the future is central to our work. We move, treat, analyze, and return water to the environment, and we help people use water efficiently, in their homes, buildings, factories and farms. In more than 150 countries, we have strong, long-standing relationships with customers who know us for our powerful combination of leading product brands and applications expertise, backed by a legacy of innovation.

For more information on how Xylem can help you, go to xyleminc.com



Xylem Inc.
2881 East Bayard St. Ext., Suite A
Seneca Falls, NY
USA
Tel: (866) 325-4210
Fax: (888) 322-5877
www.xyleminc.com

Visit our Web site for the latest version of this document and more information

The original instruction is in English. All non-English instructions are translations of the original instruction.

© 2015 Xylem Inc