

Contents

1 How to Read these Operating Instructions	5
1.1.1 Copyright, Limitation of Liability and Revision Rights	5
1.1.4 Symbols	6
2 Safety	7
2.1.2 General Warning	8
2.1.3 Before Commencing Repair Work	8
2.1.4 Special Conditions	8
2.1.5 Avoid Unintended Start	8
2.1.6 Safe Stop Installation	8
2.1.7 Safe Stop of the Frequency Converter	10
2.1.8 IT Mains	11
3 Introduction to the Low Harmonic Drive	12
3.1.1 Working Principle	12
3.1.2 IEEE519 Compliance	12
3.1.3 Ordering Form Type Code	13
4 How to Install	14
4.1 How to Get Started	14
4.2 Pre-installation	14
4.2.1 Planning the Installation Site	14
4.2.2 Receiving the Frequency Converter	15
4.2.3 Transportation and Unpacking	15
4.2.4 Lifting	15
4.2.5 Mechanical Dimensions	16
4.3 Mechanical Installation	21
4.3.3 Terminal Locations - Frame Size D13	22
4.3.4 Terminal Locations - Frame Size E9	23
4.3.5 Terminal Locations - Frame Size F18	25
4.3.6 Cooling and Airflow	28
4.4 Field Installation of Options	32
4.4.1 Installation of Input Plate Options	32
4.4.2 Installation of Mains Shield for Frequency Converters	33
4.5 Frame Size F Panel Options	33
4.6 Electrical Installation	34
4.6.1 Power Connections	34
4.6.2 Earthing	43
4.6.4 RFI Switch	43
4.6.5 Torque	43

4.6.6 Shielded Cables	44
4.6.10 Load Sharing	45
4.6.11 Mains Connection	45
4.6.12 External Fan Supply	46
4.6.13 Power and Control Wiring for Unscreened Cables	46
4.6.14 Fuses	46
4.6.15 Fuse Specifications	47
4.6.21 Control Cable Routing	49
4.6.23 Electrical Installation, Control Terminals	51
4.7 Connection Examples for Control of Motor with External Signal Provider	51
4.7.1 Start/Stop	52
4.7.2 Pulse Start/Stop	52
4.8 Electrical Installation - Additional	54
4.8.1 Electrical Installation, Control Cables	54
4.8.2 Switches S201, S202, and S801	56
4.9 Final Set-up and Test	56
4.10 Additional Connections	57
4.10.1 Mechanical Brake Control	57
4.10.3 Motor Thermal Protection	58
5 How to Operate the Low Harmonic Drive	59
5.1.2 How to Operate Graphical LCP (GLCP)	59
6 How to Programme the Low Harmonic Drive	67
6.1 How to Programme the Frequency Converter	67
6.1.2 Quick Menu Mode	70
6.1.3 Function Set-ups	74
6.2 How to Programme the Active Filter	96
6.2.1 Using the Low Harmonic Drive in NPN Mode	96
6.3 Parameter Lists - Frequency Converter	97
6.3.1 Main Menu Structure	97
6.3.2 0-** Operation and Display	98
6.3.3 1-** Load / Motor	99
6.3.4 2-** Brakes	100
6.3.5 3-** Reference / Ramps	101
6.3.6 4-** Limits / Warnings	101
6.3.7 5-** Digital In / Out	102
6.3.8 6-** Analog In / Out	103
6.3.9 8-** Communication and Options	104
6.3.10 9-** Profibus	105
6.3.11 10-** CAN Fieldbus	106

6.3.12 11-** LonWorks	108
6.3.13 13-** Smart Logic Controller	108
6.3.14 14-** Special Functions	108
6.3.15 15-** Drive Information	110
6.3.16 16-** Data Readouts	111
6.3.17 18-** Info & Readouts	112
6.3.18 20-** FC Closed Loop	113
6.3.19 21-** Ext. Closed Loop	114
6.3.20 22-** Application Functions	115
6.3.21 23-** Time Based Functions	117
6.3.22 24-** Application Functions 2	118
6.3.23 25-** Cascade Pack Controller	118
6.3.24 26-** Analog I / O Option MCB 109	119
6.4 Parameter Lists - Active Filter	120
6.4.1 0-** Operation/Display	120
6.4.2 5-** Digital In/Out	121
6.4.3 8-** Comm. and Options	122
6.4.4 14-** Special Functions	122
6.4.5 15-** FC Information	122
6.4.6 16-** Data Readouts	124
6.4.7 300-** AF Settings	125
6.4.8 301-** AF Readouts	126
7 RS-485 Installation and Set-up	127
7.1.1 Overview	127
7.1.3 EMC Precautions	128
7.2 Network Configuration	128
7.2.1 Frequency Converter Set-up	128
7.3 FC Protocol Message Framing Structure	128
7.3.1 Content of a Character (byte)	128
7.3.2 Telegram Structure	128
7.3.3 Telegram Length (LGE)	129
7.3.4 Frequency Converter Address (ADR)	129
7.3.5 Data Control Byte (BCC)	129
7.3.6 The Data Field	129
7.3.7 The PKE Field	130
7.3.8 Parameter Number (PNU)	131
7.3.9 Index (IND)	131
7.3.10 Parameter Value (PWE)	131
7.3.11 Supported Data Types	132
7.3.12 Conversion	132

7.3.13 Process Words (PCD)	132
7.4 Examples	132
7.4.1 Writing a Parameter Value	132
7.4.2 Reading a Parameter Value	133
7.5 How to Access Parameters	133
7.5.1 Parameter Handling	133
7.5.2 Storage of Data	133
7.5.3 IND	133
7.5.4 Text Blocks	133
7.5.5 Conversion Factor	133
7.5.6 Parameter Values	133
8 General Specifications	134
8.1 Filter Specifications	141
9 Troubleshooting	142
9.1 Alarms and Warnings - Frequency Converter (right LCP)	142
9.1.1 Fault Messages	146
9.2 Alarms and Warnings - Filter (Left LCP)	153
Index	159

1 How to Read these Operating Instructions

1.1.1 Copyright, Limitation of Liability and Revision Rights

This publication contains information proprietary to Danfoss. By accepting and using this manual the user agrees that the information contained herein will be used solely for operating equipment from Danfoss or equipment from other vendors provided that such equipment is intended for communication with Danfoss equipment over a serial communication link. This publication is protected under the Copyright laws of Denmark and most other countries.

Danfoss does not warrant that a software program produced according to the guidelines provided in this manual will function properly in every physical, hardware or software environment.

Although Danfoss has tested and reviewed the documentation within this manual, Danfoss makes no warranty or representation, neither expressed nor implied, with respect to this documentation, including its quality, performance, or fitness for a particular purpose.

In no event shall Danfoss be liable for direct, indirect, special, incidental, or consequential damages arising out of the use, or the inability to use information contained in this manual, even if advised of the possibility of such damages. In particular, Danfoss is not responsible for any costs, including but not limited to those incurred as a result of lost profits or revenue, loss or damage of equipment, loss of computer programs, loss of data, the costs to substitute these, or any claims by third parties.

Danfoss reserves the right to revise this publication at any time and to make changes to its contents without prior

notice or any obligation to notify former or present users of such revisions or changes.

1.1.2 Available Literature for VLT HVAC Drive

- Design Guide MG11BXYY entails all technical information about the frequency converter and customer design and applications.
- Programming Guide MG11CXYY provides information on how to programme and includes complete parameter descriptions.
- Application Note, Temperature Derating Guide, MN11AXYY
- PC-based Configuration Tool MCT 10, MG10AXYY enables the user to configure the frequency converter from a Windows™ based PC environment.
- Danfoss VLT® Energy Box software at www.danfoss.com/BusinessAreas/DrivesSolutions then choose PC Software Download
- Operating Instructions VLT HVAC Drive BACnet, MG11DXYY
- Operating Instructions VLT HVAC Drive Metasys, MG11GXYY
- Operating Instructions VLT HVAC Drive FLN, MG11ZXYY

x = Revision number



yy = Language code

Danfoss technical literature is available in print from your local Danfoss Sales Office or online at:

www.danfoss.com/BusinessAreas/DrivesSolutions/Documentations/Technical+Documentation.htm

1.1.3 Software Version and Approvals

VLT HVAC Drive
Software version: 3.7.x

This manual can be used with all VLT HVAC Low Harmonic Drive frequency converters with software version 3.7.x.
The software version number can be seen from *15-43 Software Version*.

Table 1.1

NOTE

The Low Harmonic Drive has two LCPs, one for the frequency converter (to the right) and one for the active filter (to the left). Each LCP controls only the unit it is connected to and there is no communication between the two LCPs.

1.1.4 Symbols

The following symbols are used in this manual.

⚠ WARNING

Indicates a potentially hazardous situation which, if not avoided, could result in death or serious injury.

⚠ CAUTION

Indicates a potentially hazardous situation which, if not avoided, may result in minor or moderate injury. It may also be used to alert against unsafe practices.

CAUTION

Indicates a situation that may result in equipment or property-damage-only accidents.

NOTE

Indicates highlighted information that should be regarded with attention to avoid mistakes or operate equipment at less than optimal performance.

* Indicates default setting

Table 1.2

2 Safety

2.1.1 Safety Note

⚠ WARNING

The voltage of the frequency converter is dangerous whenever connected to mains. Incorrect installation of the motor, frequency converter or fieldbus may cause damage to the equipment, serious personal injury or death. Consequently, the instructions in this manual, as well as national and local rules and safety regulations, must be complied with.

Safety Regulations

1. The frequency converter must be disconnected from mains if repair work is to be carried out. Check that the mains supply has been disconnected and that the necessary time has passed before removing motor and mains plugs.
2. The stop key [Reset] on the LCP of the frequency converter does not disconnect the equipment from mains and is thus not to be used as a safety switch.
3. Correct protective earthing of the equipment must be established, the user must be protected against supply voltage, and the motor must be protected against overload in accordance with applicable national and local regulations.
4. The earth leakage currents are higher than 3.5 mA.
5. Protection against motor overload is set by *1-90 Motor Thermal Protection*. If this function is desired, set *1-90 Motor Thermal Protection* to data value [ETR trip] (default value) or data value [ETR warning].

NOTE

The function is initialised at 1.16 x rated motor current and rated motor frequency.

For the North American market: The ETR functions provide class 20 motor overload protection in accordance with NEC.

6. Note that the frequency converter has voltage inputs other than L1, L2 and L3, when load sharing (linking of DC intermediate circuit) and external 24 V DC have been installed. Check that all voltage inputs have been disconnected and that the necessary time has passed before commencing repair work.

Installation at High Altitudes

⚠ WARNING

Installation at high altitude

At altitudes above 3 km, please contact Danfoss regarding PELV.

Warning against Unintended Start

1. The motor can be brought to a stop by means of digital commands, bus commands, references or a local stop, while the frequency converter is connected to mains. If personal safety considerations make it necessary to ensure that no unintended start occurs, these stop functions are not sufficient. 2. While parameters are being changed, the motor may start. Consequently, the stop key [Reset] must always be activated; following which data can be modified. 3. A motor that has been stopped may start if faults occur in the electronics of the frequency converter, or if a temporary overload or a fault in the supply mains or the motor connection ceases.

⚠ WARNING

Warning:

Touching the electrical parts may be fatal - even after the equipment has been disconnected from mains.

Also make sure that other voltage inputs have been disconnected, such as external 24 V DC, load sharing (linkage of DC intermediate circuit), as well as the motor connection for kinetic back up.

2.1.2 General Warning

⚠ WARNING

Warning

Touching the electrical parts may be fatal - even after the equipment has been disconnected from mains.

Also make sure that other voltage inputs have been disconnected, (linkage of DC intermediate circuit), as well as the motor connection for kinetic back-up.

Before touching any potentially live parts of the frequency converter, wait at least as follows:

380-480 V, 160-250 kW, wait at least 20 minutes.

380-480 V, 315-710 kW, wait at least 40 minutes.

Shorter time is allowed only if indicated on the nameplate for the specific unit. Be aware that there may be high voltage on the DC links even when the Control Card LEDs are turned off. A red LED is mounted on a circuit board inside both the frequency converter and the active filter to indicate the DC bus voltages. The red LED will stay lit until the DC link is 50 V DC or lower.

⚠ WARNING

Leakage Current

The earth leakage current from the frequency converter exceeds 3.5 mA. According to IEC 61800-5-1 a reinforced Protective Earth connection must be ensured with a min. 10 mm² Cu or 16 mm² Al PE-wire or an additional PE wire - with the same cable cross section as the Mains wiring - must be terminated separately.

Residual Current Device

This product can cause a DC current in the protective conductor. Where a residual current device (RCD) is used for extra protection, only an RCD of Type B (time delayed) shall be used on the supply side of this product. See also RCD Application Note MN90GX02.

Protective earthing of the frequency converter and the use of RCDs must always follow national and local regulations.

2.1.3 Before Commencing Repair Work

1. Disconnect the frequency converter from mains
2. Disconnect DC bus terminals 88 and 89
3. Wait at least the time mentioned in 2.1.2 *General Warning*

2.1.4 Special Conditions

Electrical ratings

The rating indicated on the nameplate of the frequency converter is based on a typical 3-phase mains power supply, within the specified voltage, current and temperature range, which is expected to be used in most applications.

The frequency converters also support other special applications, which affect the electrical ratings of the frequency converter. Special conditions which affect the electrical ratings might be:

- Single phase applications
- High temperature applications which require derating of the electrical ratings
- Marine applications with more severe environmental conditions.

Consult the relevant clauses in these instructions and in the Design Guide for information about the electrical ratings.

Installation requirements

The overall electrical safety of the frequency converter requires special installation considerations regarding:

- Fuses and circuit breakers for over-current and short-circuit protection
- Selection of power cables (mains, motor, brake, loadsharing and relay)
- Grid configuration (IT,TN, grounded leg, etc.)
- Safety of low-voltage ports (PELV conditions).

Consult the relevant clauses in these instructions and in the Design Guide for information about the installation requirements.

2.1.5 Avoid Unintended Start

⚠ WARNING

While the frequency converter is connected to mains, the motor can be started/stopped using digital commands, bus commands, references or via the Local Control Panel.

- Disconnect the frequency converter from mains whenever personal safety considerations make it necessary to avoid unintended start.
- To avoid unintended start, always activate the [Off] key before changing parameters.
- Unless terminal 37 is turned off, an electronic fault, temporary overload, a fault in the mains supply, or lost motor connection may cause a stopped motor to start.

2.1.6 Safe Stop Installation

To carry out an installation of a Category 0 Stop (EN60204) in conformity with Safety Category 3 (EN954-1), follow these instructions:

1. The bridge (jumper) between Terminal 37 and 24 V DC must be removed. Cutting or breaking the jumper is not sufficient. Remove it entirely to

avoid short-circuiting. See jumper on *Illustration 2.1*.

2. Connect terminal 37 to 24 V DC by a short-circuit protected cable. The 24 V DC voltage supply must be interruptible by an EN954-1 Category 3 circuit interrupt device. If the interrupt device and the frequency converter are placed in the same installation panel, an unscreened cable can be used instead of a screened one.

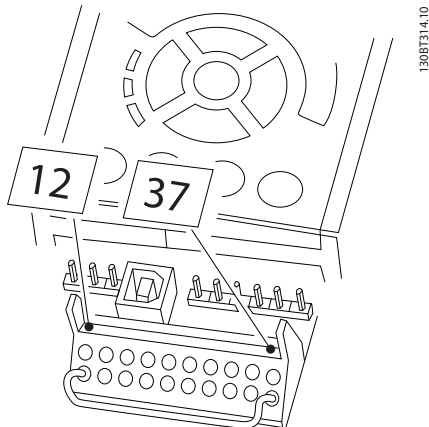

Illustration 2.1 Bridge Jumper between Terminal 37 and 24 V DC

Illustration 2.2 shows a Stopping Category 0 (EN 60204-1) with safety Category 3 (EN 954-1). The circuit interrupt is caused by an opening door contact. *Illustration 2.2* also shows how to connect a non-safety related hardware coast.

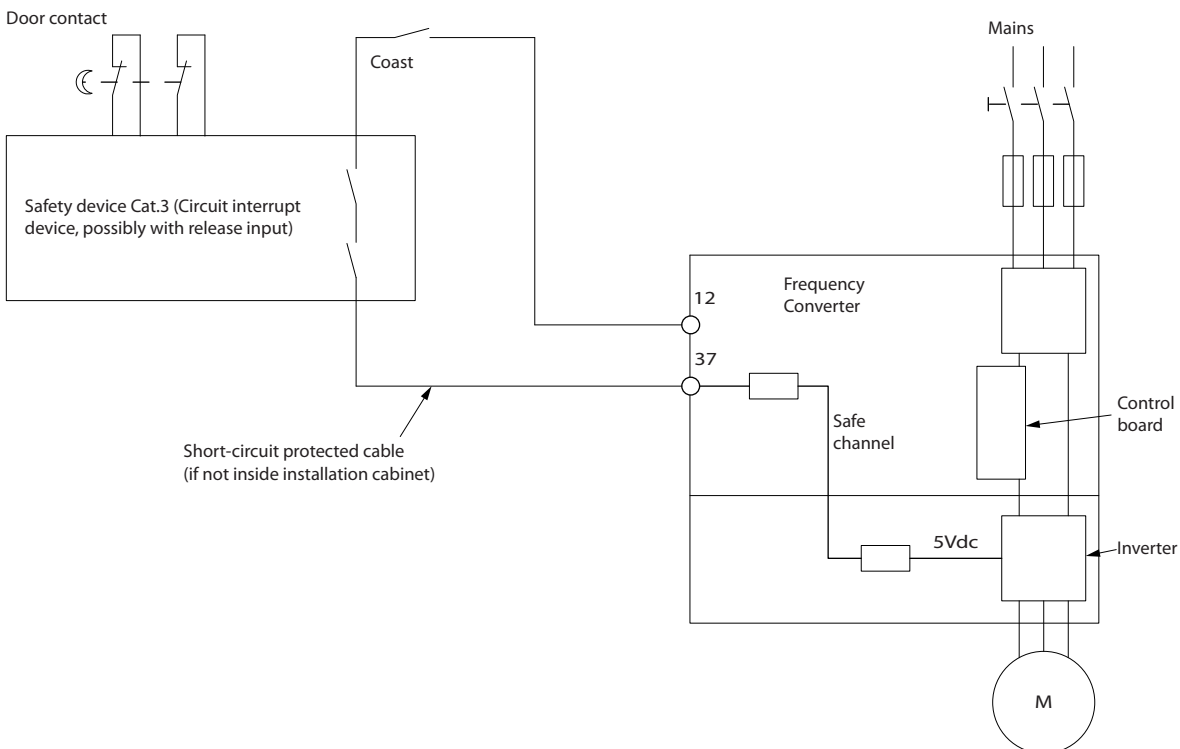

Illustration 2.2 Illustration of the essential aspects of an installation to achieve a Stopping Category 0 (EN 60204-1) with safety Category 3 (EN 954-1).

2

2.1.7 Safe Stop of the Frequency Converter

For versions fitted with a Safe Stop terminal 37 input, the frequency converter can perform the safety function *Safe Torque Off* (As defined by draft CD IEC 61800-5-2) or *Stop Category 0* (as defined in EN 60204-1).

It is designed and approved suitable for the requirements of Safety Category 3 in EN 954-1. This functionality is called Safe Stop. Before integration and use of Safe Stop in an

installation, a thorough risk analysis on the installation must be carried out in order to determine whether the Safe Stop functionality and safety category are appropriate and sufficient. In order to install and use the Safe Stop function in accordance with the requirements of Safety Category 3 in EN 954-1, the related information and instructions of the *Design Guide* must be followed. The information and instructions of the Operating Instructions are not sufficient for a correct and safe use of the Safe Stop functionality.

Prüf- und Zertifizierungsstelle
im BG-PRÜFZERT



BGIA
Berufsgenossenschaftliches
Institut für Arbeitsschutz

Hauptverband der gewerblichen
Berufsgenossenschaften

Translation

In any case, the German original shall prevail.

Type Test Certificate

05 06004

No. of certificate

Name and address of the holder of the certificate: (customer) Danfoss Drives A/S, Ulhøes 1 DK-6300 Graasten, Dänemark

Name and address of the manufacturer: Danfoss Drives A/S, Ulhøes 1 DK-6300 Graasten, Dänemark

Ref. of customer:

Ref. of Test and Certification Body: Apf/Köh VE-Nr. 2003 23220

Date of Issue: 13.04.2005

Product designation: Frequency converter with integrated safety functions

Type: VLT® Automation Drive FC 302

Intended purpose: Implementation of safety function „Safe Stop“

Testing based on: EN 954-1, 1997-03, DKE AK 226.03, 1998-06, EN ISO 13849-2; 2003-12, EN 61800-3, 2001-02, EN 61800-5-1, 2003-09,

Test certificate: No.: 2003 23220 from 13.04.2005

Remarks: The presented types of the frequency converter FC 302 meet the requirements laid down in the test bases. With correct wiring a category 3 according to DIN EN 954-1 is reached for the safety function.

The type tested complies with the provisions laid down in the directive 98/37/EC (Machinery).

Further conditions are laid down in the Rules of Procedure for Testing and Certification of April 2004.

Head of certification body

(Prof. Dr. rer. nat. Dietmar Reinert)

Certification officer

(Dipl.-Ing. R. Apfeld)

PZB10E
01.05



Postal address:
53754 Sankt Augustin

Office:
Alte Heerstraße 111
53757 Sankt Augustin

Phone: 0 22 41/2 31-02
Fax: 0 22 41/2 31-22 34

130BA373.11

Illustration 2.3

2.1.8 IT Mains

⚠ WARNING

IT mains

Do not connect frequency converters with RFI-filters to mains supplies with a voltage between phase and earth of more than 440 V for 400 Vs and 760 V for 690 V converters.

For 400 V IT mains and delta earth (grounded leg), mains voltage may exceed 440 V between phase and earth.

14-50 RFI Filter can be used to disconnect the internal RFI capacitors from the RFI filter to ground. *14-50 RFI Filter* on both the drive and the filter must be turned off.

2.1.9 Disposal Instruction

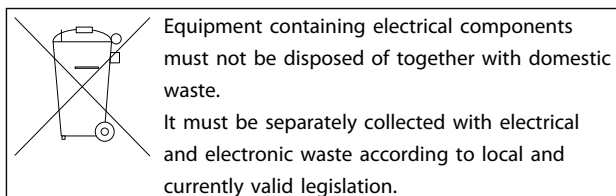

Table 2.1

3 Introduction to the Low Harmonic Drive

3.1.1 Working Principle

3

The VLT Low Harmonic Drive is a VLT High Power frequency converter with an integrated active filter. An active filter is a device that actively monitors harmonic

distortion levels and injects compensative harmonic current onto the line to cancel out the harmonics.

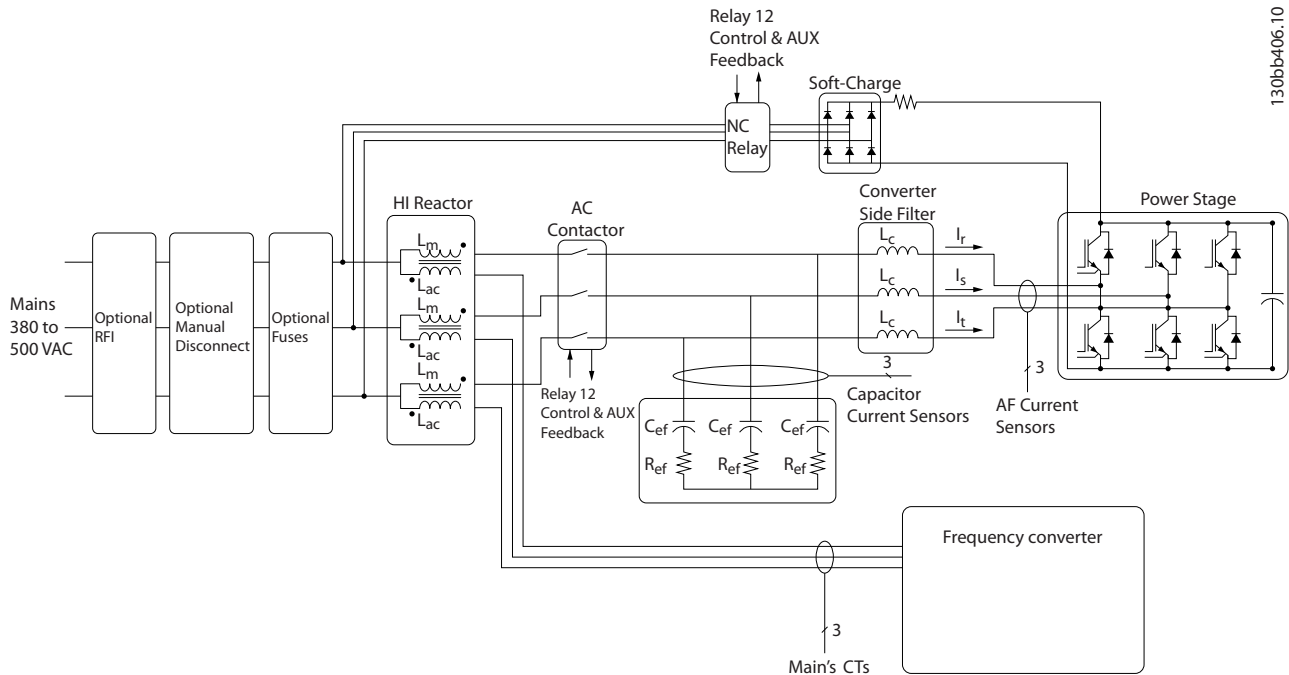

Illustration 3.1 Basic Layout for the Low Harmonic Drive

3.1.2 IEEE519 Compliance

Low harmonic drives are designed to draw an ideal sinusoidal current waveform from the supply grid with a power factor of 1. Where traditional non linear load draws pulse shaped currents the low harmonic drive compensates that via the parallel filter path lowering the stress on the supply grid. The Low harmonic drive meets the toughest harmonic standards and has a THiD of less than 5% at full load for <3% pre-distortion on a 3% unbalanced three-phased grid. The unit is designed to meet IEEE519 recommendation for $I_{sc}/I_L > 20$ for both uneven and even individual harmonic levels. The filter portion of the low harmonic drives has a progressive switching frequency which leads to a wide frequency spreads giving lower individual harmonic levels above the 50th.

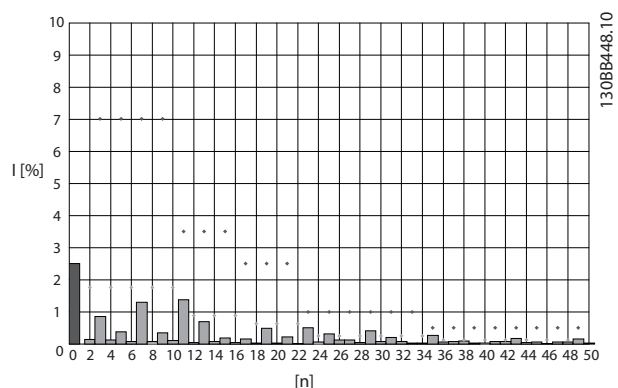

Illustration 3.2 Typical harmonic frequency spectrum and THD value at the mains terminals of the frequency converter

n = harmonic order

◇.....IEEE519 ($I_{sc}/I_L > 20$) limits for individual harmonics

3.1.3 Ordering Form Type Code

It is possible to design a VLT Low Harmonic Drive according to the application requirements by using the ordering number system.

1	2	3	4	5	6	7	8	9	10	11	12	13	14	15	16	17	18	19	20	21	22	23	24	25	26	27	28	29	-	-	30
F	C	-	X	0	2	P	X	X	0	T	4	E	2	1	N	2	X	G	C	X	X	X	S	X	X	X	X	X	.	.	X

Table 3.1

Product groups	1-3	
Frequency converter series	4-6	
Power rating	8-10	
Phases	11	
Mains Voltage	12	
Enclosure	13-15	
Enclosure type		
Enclosure class		
Control supply voltage		
Hardware configuration		
RFI filter	16-17	
Brake	18	
Display (LCP)	19	
Coating PCB	20	
Mains option	21	
Adaptation A	22	
Adaptation B	23	
Software release	24-27	
Software language	28	
A options	29-30	
B options	31-32	
C0 options, MCO	33-34	
C1 options	35	
C option software	36-37	
D options	38-39	

Configurator on the Internet. For more information on the options available, see the *Design Guide*.

Table 3.2

To order a VLT Low Harmonic Drive, type the letter "N" in position 16 of the type code string. Not all choices/options are available for each frequency converter variant. To verify if the appropriate version is available, consult the Drive

4 How to Install

4

4.1 How to Get Started

This chapter covers mechanical and electrical installations to and from power terminals and control card terminals. Electrical installation of options is described in the relevant Operating Instructions and Design Guide.

The frequency converter is designed to achieve a quick and EMC-correct installation by following the steps described below.

⚠ WARNING

Read the safety instructions before installing the unit. Failure to follow recommendations could result in death or serious injury.

Mechanical Installation

- Mechanical mounting

Electrical Installation

- Connection to Mains and Protecting Earth
- Motor connection and cables
- Fuses and circuit breakers
- Control terminals - cables

Quick Setup

- Local Control Panel (LCP) of frequency converter
- Local Control Panel of filter
- Automatic Motor Adaptation, AMA
- Programming

Frame size is depending on enclosure type, power range, and mains voltage.

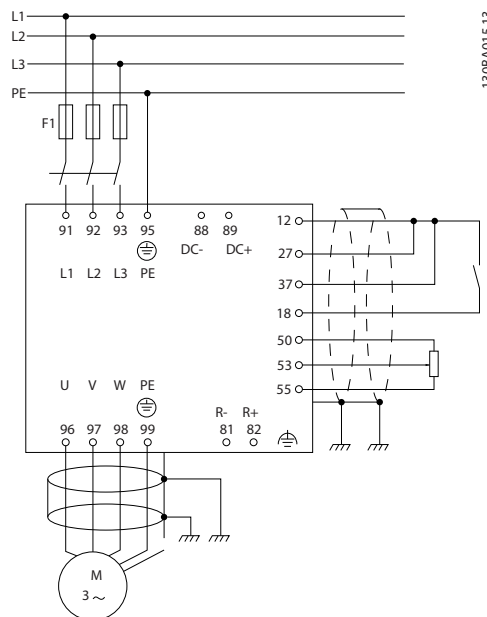

Illustration 4.1 Diagram showing basic installation including mains, motor, start/stop key, and potentiometer for speed adjustment.

4.2 Pre-installation

4.2.1 Planning the Installation Site

CAUTION

Before performing the installation it is important to plan the installation of the frequency converter. Neglecting this may result in extra work during and after installation.

Select the best possible operation site by considering the following (see details on the following pages, and the respective Design Guides)

- Ambient operating temperature
- Installation method
- How to cool the unit
- Position of the frequency converter
- Cable routing
- Ensure the power source supplies the correct voltage and necessary current
- Ensure that the motor current rating is within the maximum current from the frequency converter
- If the frequency converter is without built-in fuses, ensure that the external fuses are rated correctly.

4.2.2 Receiving the Frequency Converter

When receiving the frequency converter, make sure that the packaging is intact, and be aware of any damage that might have occurred to the unit during transport. In case damage has occurred, contact immediately the shipping company to claim the damage.

4.2.3 Transportation and Unpacking

Before unpacking the frequency converter it is recommended that it is located as close as possible to the final installation site.

Remove the box and handle the frequency converter on the pallet, as long as possible.

4.2.4 Lifting

Always lift the frequency converter in the dedicated lifting eyes. For all D and E frames, use a bar to avoid bending the lifting holes of the frequency converter.

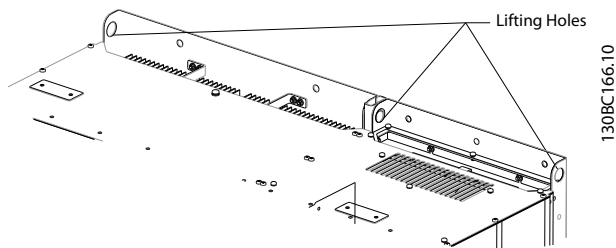

Illustration 4.2 Recommended Lifting Method, Frame Size D13.

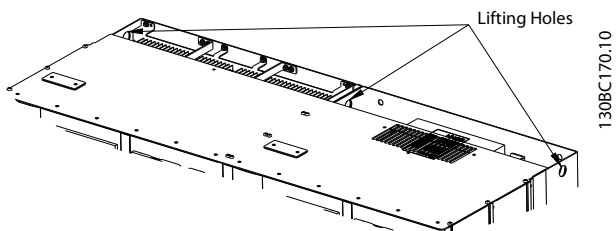

Illustration 4.3 Recommended Lifting Method, Frame Size E9

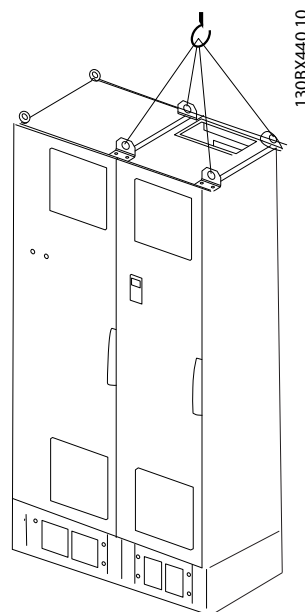

Illustration 4.4 Recommended Lifting Method, Frame Size F18 - Filter Section.

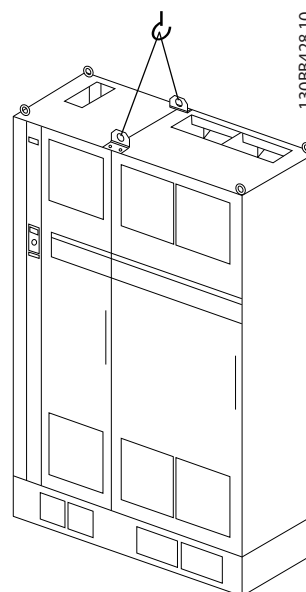

Illustration 4.5 Recommended Lifting Method, Frame Size F18 - Drive Section.

NOTE

Note the plinth is provided in the same packaging as the frequency converter but is not attached to frame size F during shipment. The plinth is required to allow airflow to the drive to provide proper cooling. The F frames should be positioned on top of the plinth in the final installation location. The angle from the top of the drive to the lifting cable should be 60° or greater.

In addition to the drawing above a spreader bar is an acceptable way to lift the F Frame.

4.2.5 Mechanical Dimensions

4

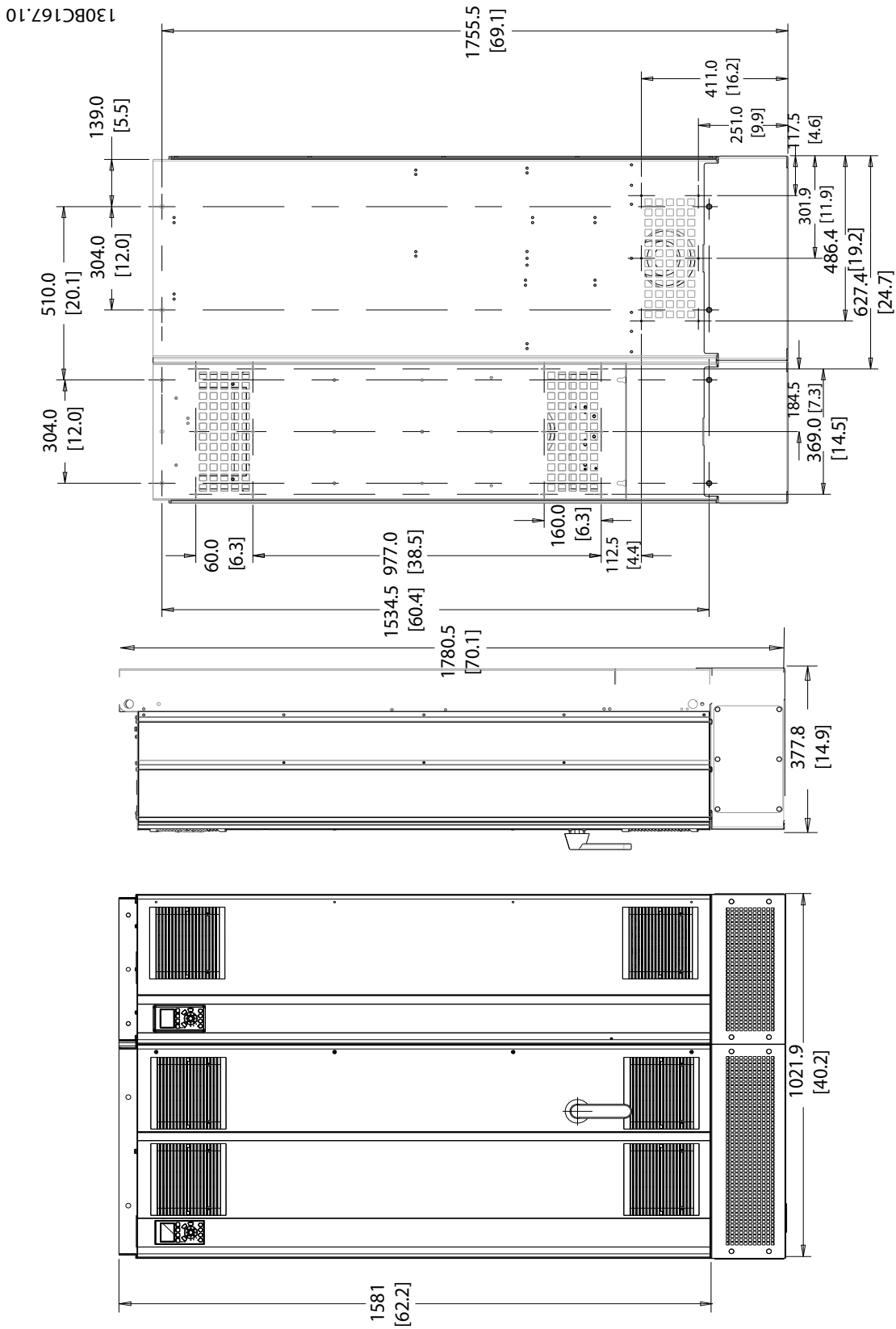
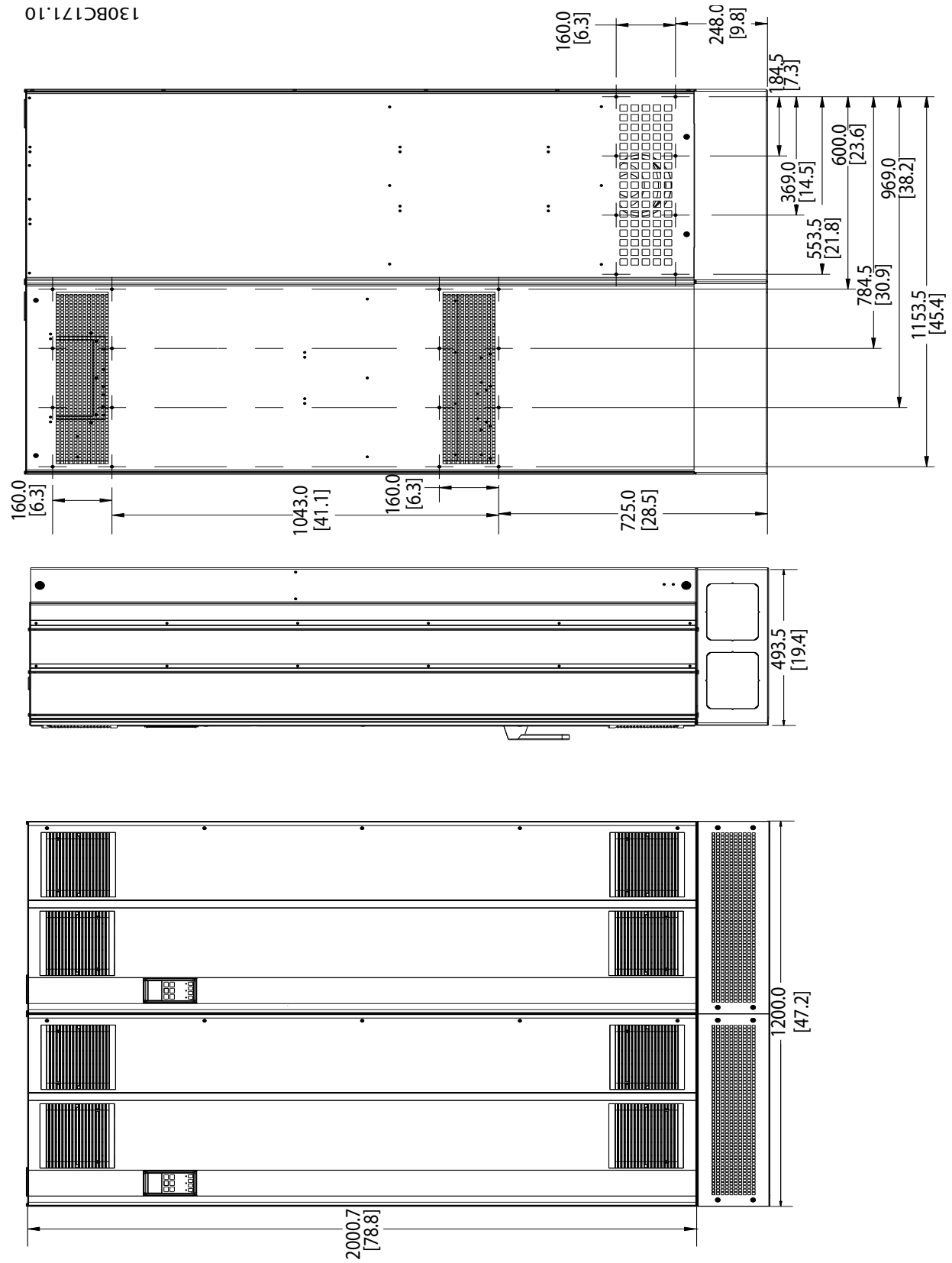

Illustration 4.6 Frame Size D13



4

Illustration 4.7 Frame Size E9

4

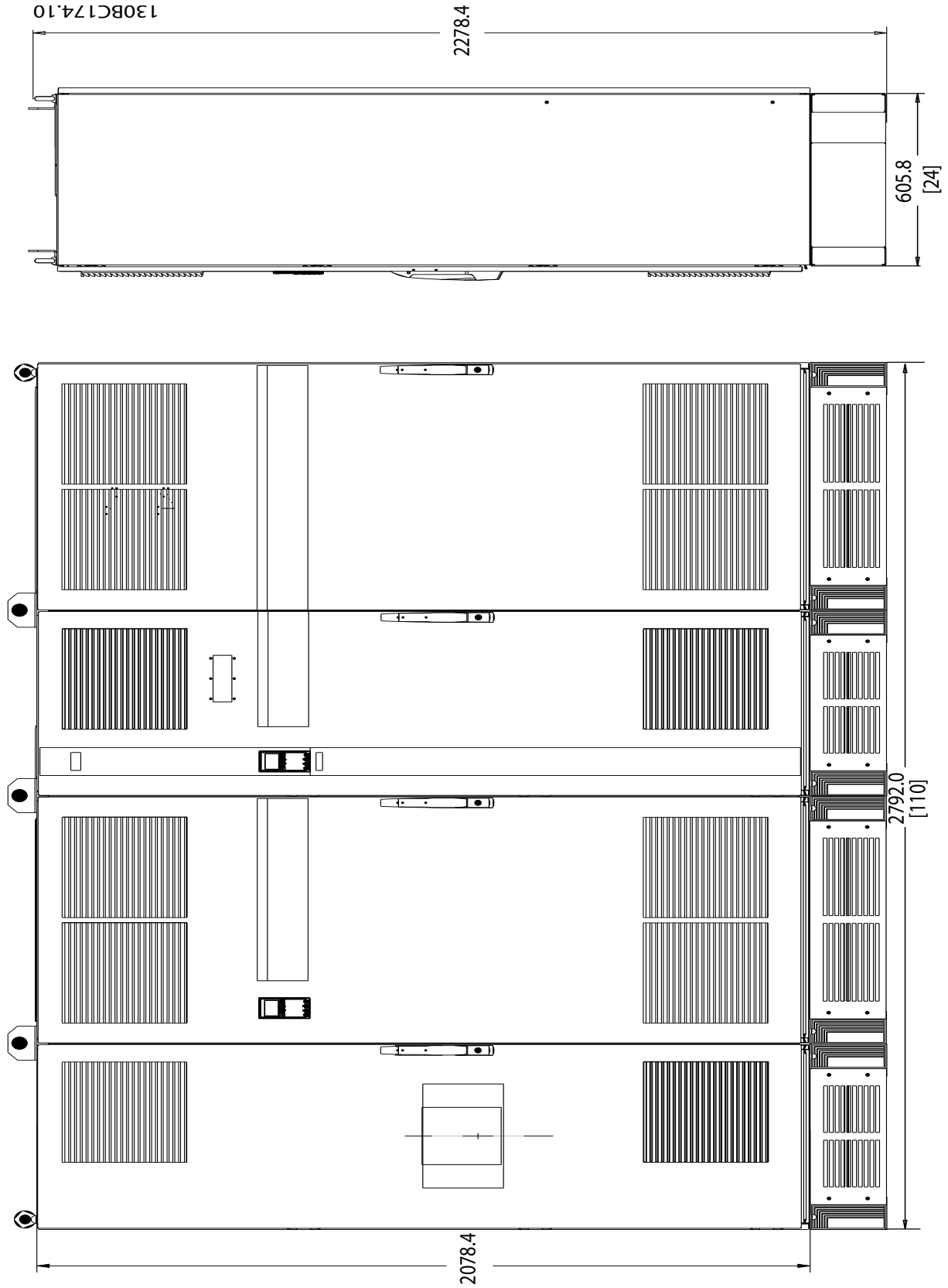

Illustration 4.8 Frame Size F18, Front and Side View

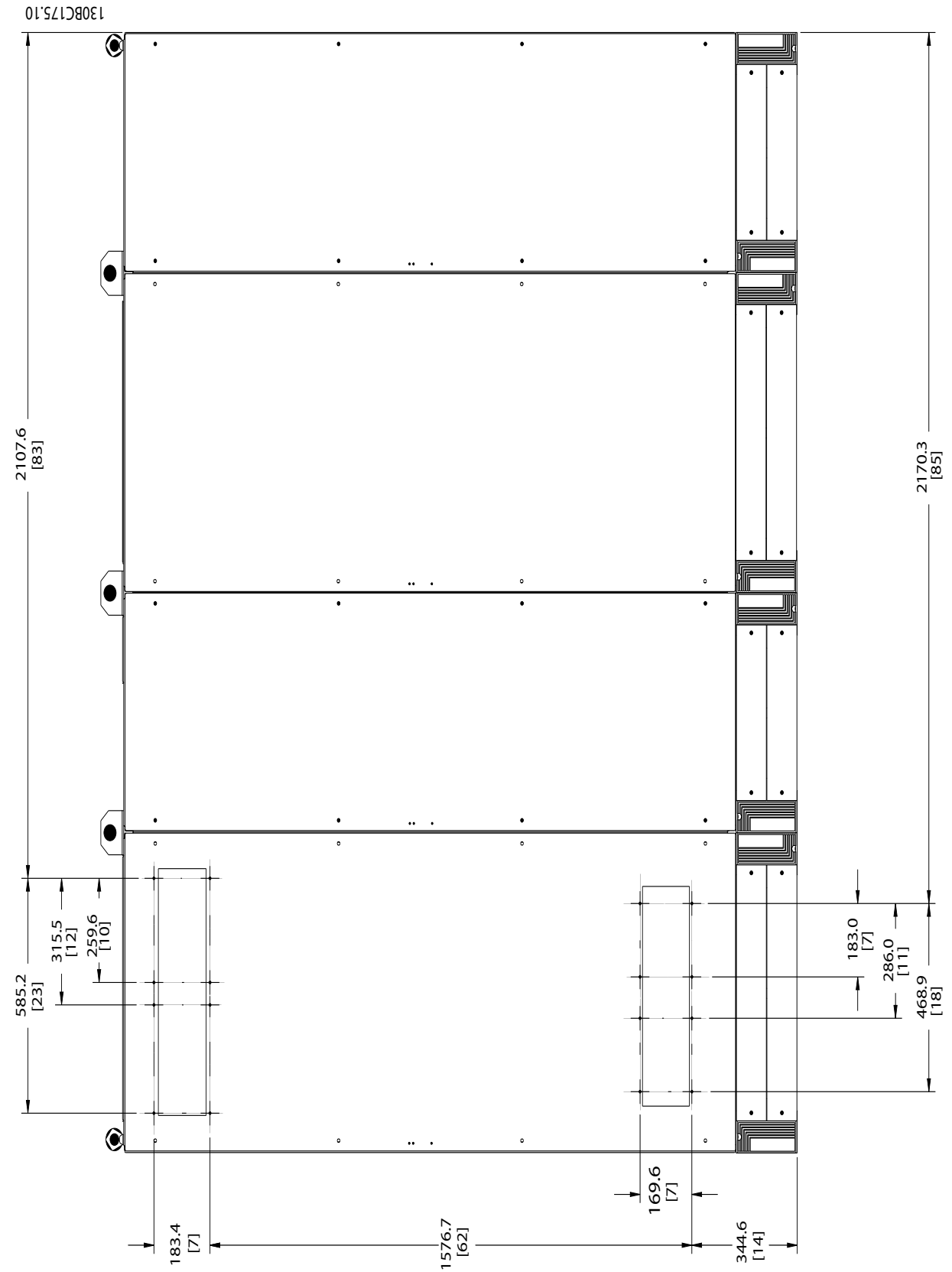

Illustration 4.9 Frame Size F18, Back View

Frame size		D13	E9
Enclosure protection	IP	21/54	21/54*
	NEMA	Type 1/Type 12	Type 1/Type 12
Normal overload rated power - 110% overload torque		160-250 kW at 400 V (380-480 V)	315-450 kW at 400 V (380-480 V)
Drive Dimensions	Height	1780.5 mm/70.1"	2000.7 mm/78.77"
	Width	1021.9 mm/40.23"	1200 mm/47.24"
	Depth	377.8 mm/14.87"	493.5 mm/19.43"
	Max Weight	390 kg/860 lbs.	676 kg/1490 lbs.
	Shipping Weight	435 kg/959 lbs.	721 kg/1590 lbs.

Table 4.1 Mechanical Dimensions and Rated Power, Frame Size D13 and E9

Frame size		F18
Enclosure protection	IP	21/54
	NEMA	Type 1
Normal overload rated power - 110% overload torque		500-710 kW at 400 V (380-480 V)
Drive Dimensions	Height	2278.4 mm/89.70"
	Width	2792 mm/109.92"
	Depth	605.8 mm/23.85"
	Max Weight	1900 kg/4189 lbs.
	Shipping Weight	2262 kg/4987 lbs.

Table 4.2 Mechanical Dimensions and Rated Power, Frame Size F18

4.3 Mechanical Installation

Preparation of the mechanical installation of the frequency converter must be done carefully to ensure a proper result and to avoid additional work during installation. Start taking a close look at the mechanical drawings at the end of this instruction to become familiar with the space demands.

4.3.1 Tools Needed

To perform the mechanical installation the following tools are needed:

- Drill with 10 or 12 mm drill
- Tape measure
- Screw driver
- Wrench with relevant metric sockets (7-17 mm)
- Extensions to wrench
- Sheet metal punch for conduits or cable glands
- Lifting bar to lift the unit (rod or tube max. Ø 25 mm (1 inch), able to lift minimum 1000 kg).
- Crane other lifting aid to place the unit in position
- Torx T50 tool

4.3.2 General Considerations

Space

Ensure proper space above and below the frequency converter to allow airflow and cable access. In addition space in front of the unit must be considered to enable opening of the door of the panel.

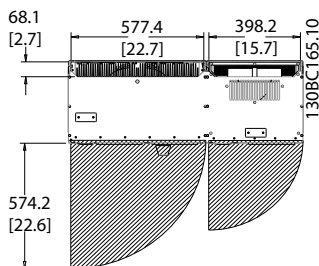

Illustration 4.10 Space in Front of IP21/IP54 Enclosure Type, Frame Size D13.

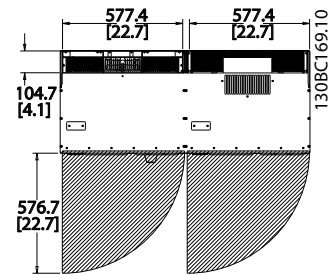

Illustration 4.11 Space in Front of IP21/IP54 Enclosure Type, Frame Size E9

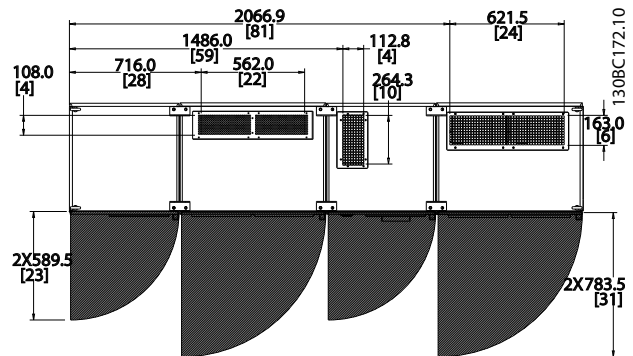

Illustration 4.12 Space in Front of IP21/IP54 Enclosure Type, Frame Size F18.

Wire access

Ensure that proper cable access is present including necessary bending allowance.

NOTE

All cable lugs/shoes must mount within the width of the terminal bus bar.

4.3.3 Terminal Locations - Frame Size D13

Take the following position of the terminals into consideration when designing for cables access.

4

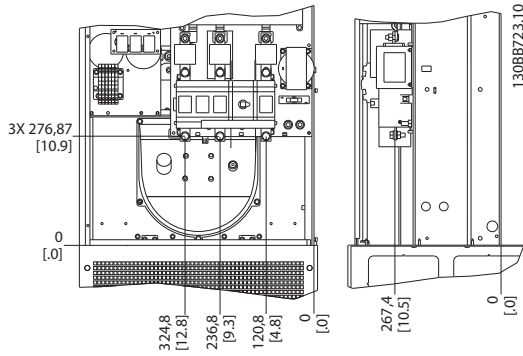

Illustration 4.13 Terminal Locations - Mains Cables

Section shown

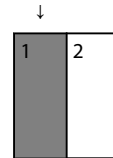

Table 4.3

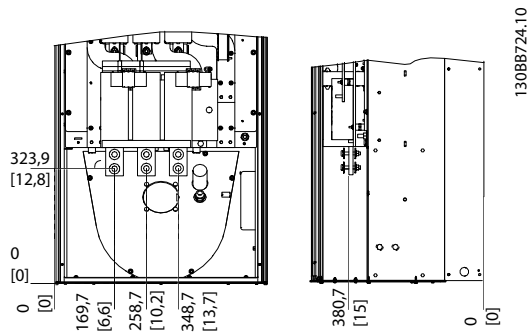

Illustration 4.13 Terminal Locations D13 Frame Size

Section shown

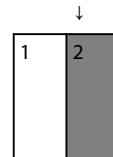

Table 4.4

NOTE

Power cables are heavy and hard to bend. Consider the optimum position of the frequency converter for ensuring easy installation of the cables.

NOTE

All D frames are available with standard input terminals or disconnect switch.

4.3.4 Terminal Locations - Frame Size E9

Take the following position of the terminals into consideration when designing the cable access.

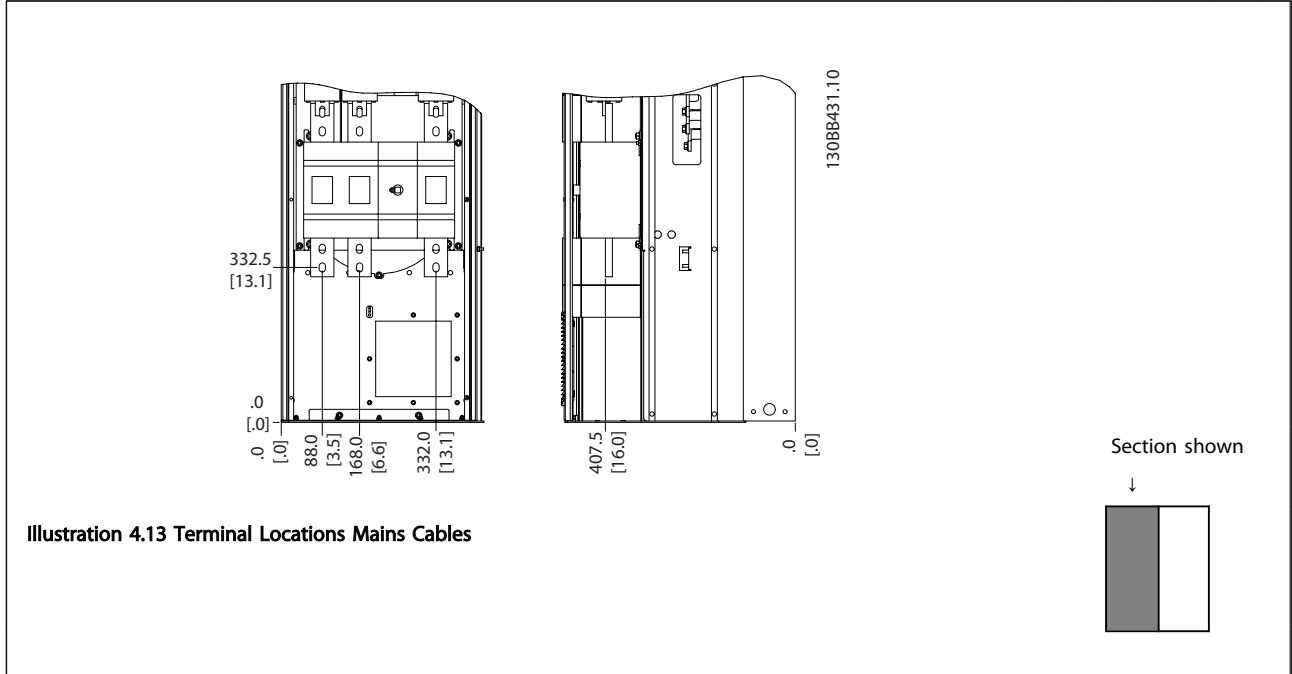

Table 4.5

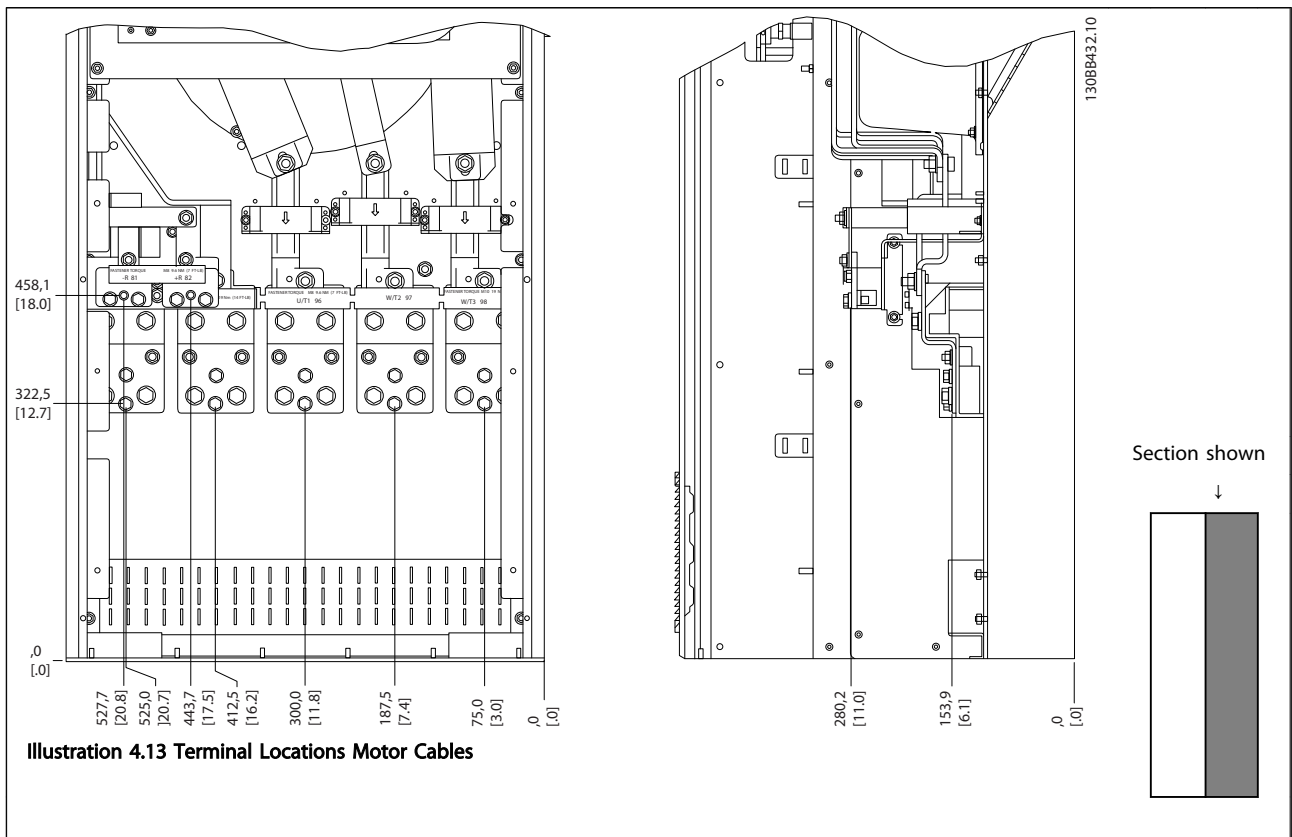

Table 4.6

NOTE

Power cables are heavy and hard to bend. Consider the optimum position of the frequency converter for ensuring easy installation of the cables.

Each terminal allows use of up to 4 cables with cable lugs or use of standard box lug. Earth is connected to relevant termination point in the frequency converter.

4

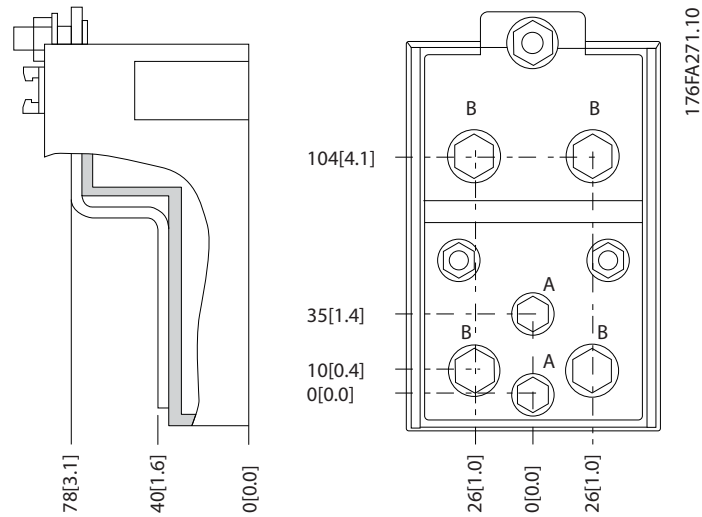
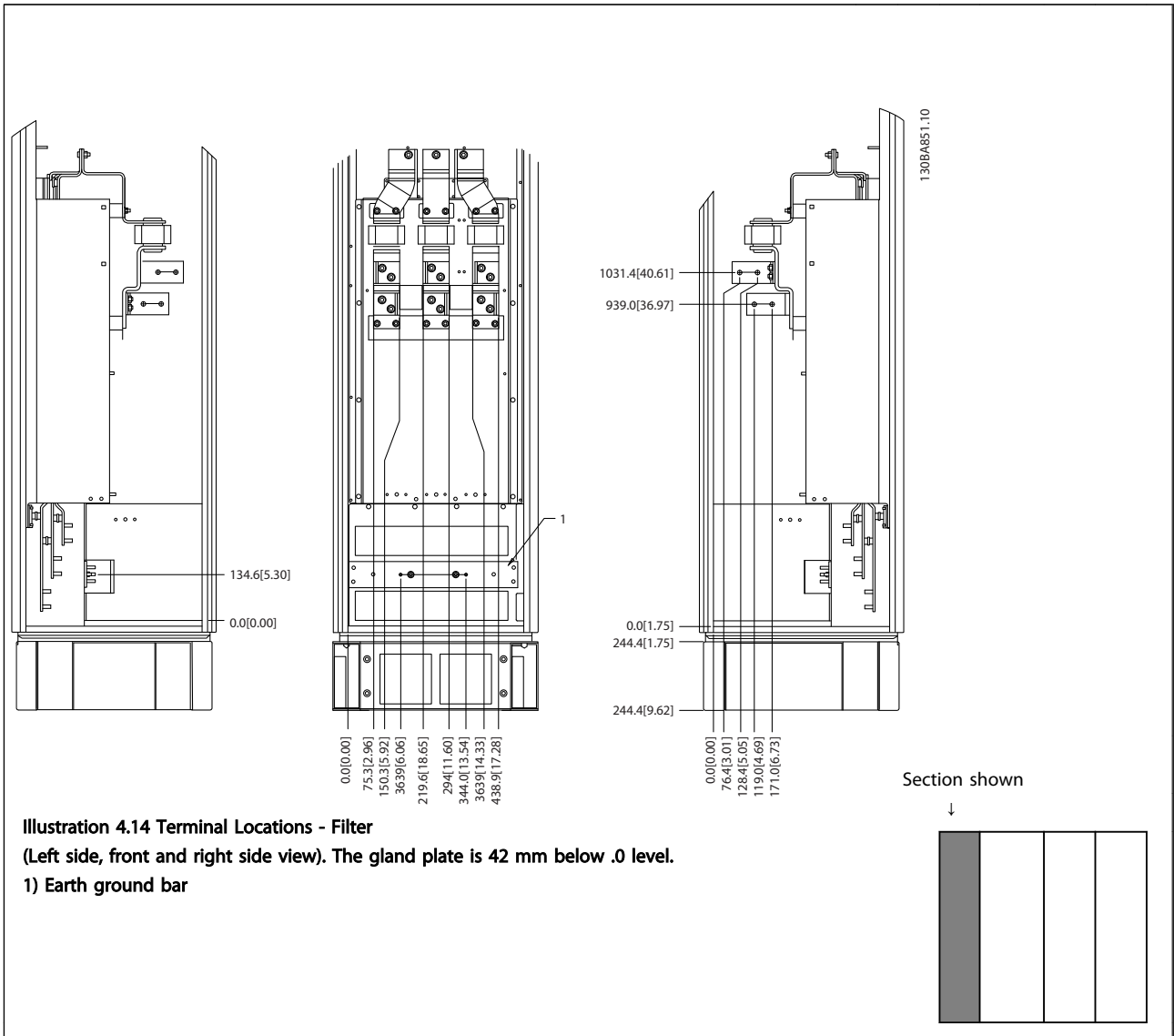

Illustration 4.13 Terminal in Details

NOTE

Power connections can be made to positions A or B.

4.3.5 Terminal Locations - Frame Size F18



4

Table 4.7

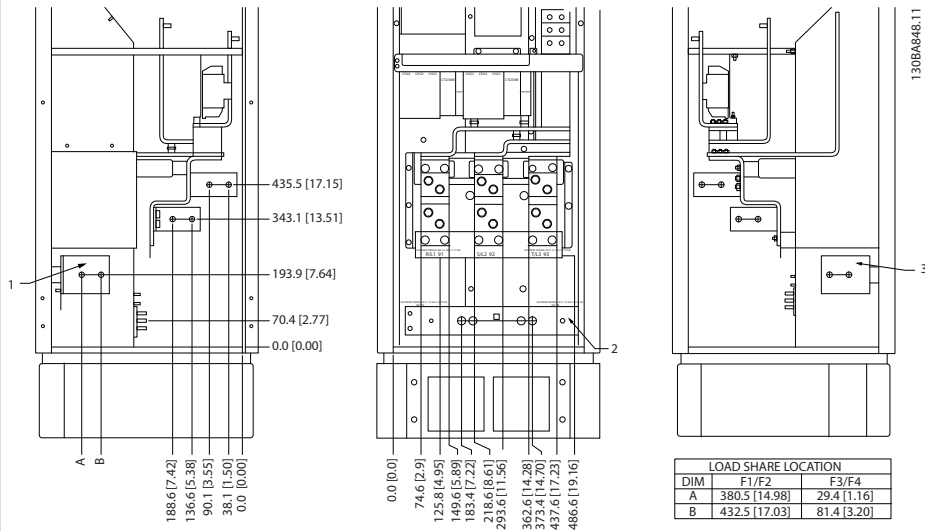

Illustration 4.14 Terminal Locations - Rectifier

(Left side, front and right side view). The gland plate is 42 mm below .0 level.

- 1) Loadshare Terminal (-)
- 2) Earth ground bar
- 3) Loadshare Terminal (+)

Section shown

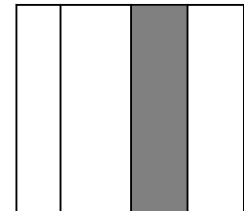

Table 4.8

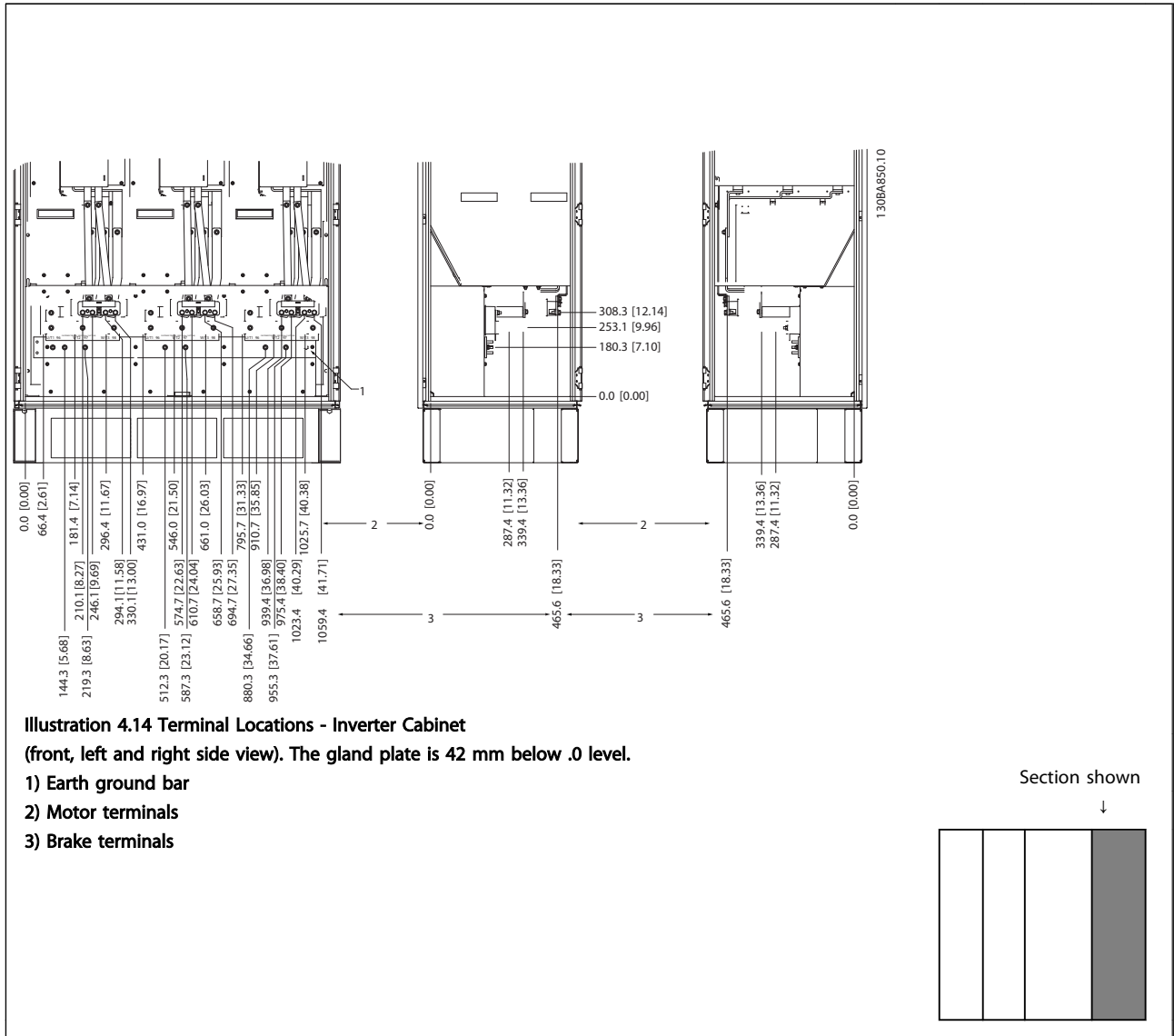

Table 4.9

4.3.6 Cooling and Airflow

Cooling

Cooling can be obtained in different ways, by using the cooling ducts in the bottom and the top of the unit, by taking air in and out the back of the unit or by combining the cooling possibilities.

Back cooling

The backchannel air can also be ventilated in and out the back of a Rittal TS8 enclosure. This offers a solution where the backchannel could take air from outside the facility and return the heat losses outside the facility thus reducing air-conditioning requirements.

NOTE

A door fan(s) is required on the enclosure to remove the heat losses not contained in the backchannel of the frequency converter and any additional losses generated from other components installed inside the enclosure. The total required air flow must be calculated so that the appropriate fans can be selected. Some enclosure manufacturers offer software for performing the calculations (i.e. Rittal Therm software).

Airflow

The necessary airflow over the heat sink must be secured. The flow rate is shown below.

Enclosure protection	Frame size	Door fan(s)/Top fan airflow Total airflow of multiple fans	Heatsink fan(s) Total airflow of multiple fans
IP21/NEMA 1 IP54/NEMA 12	D13	510 m ³ /h (300 cfm)	2295 m ³ /h (1350 cfm)
	E9 P315	680 m ³ /h (400 cfm)	2635 m ³ /h (1550 cfm)
	E9 P355-P450	680 m ³ /h (400 cfm)	2975 m ³ /h (1750 cfm)
IP21/NEMA 1	F18	4900 m ³ /h (2884 cfm)	6895 m ³ /h (4060 cfm)

Table 4.10 Heatsink Air Flow

NOTE

For the frequency converter section, the fan runs for the following reasons:

1. AMA
2. DC Hold
3. Pre-Mag
4. DC Brake
5. 60% of nominal current is exceeded
6. Specific heatsink temperature exceeded (power size dependent)
7. Specific Power Card ambient temperature exceeded (power size dependent)
8. Specific Control Card ambient temperature exceeded

Once the fan is started it will run for minimum 10 minutes.

NOTE

For the active filter, the fan runs for the following reasons:

1. Active filter running
2. Active filter not running, but mains current exceeding limit (power size dependent)
3. Specific heatsink temperature exceeded (power size dependent)
4. Specific Power Card ambient temperature exceeded (power size dependent)
5. Specific Control Card ambient temperature exceeded

Once the fan is started it will run for minimum 10 minutes.

External ducts

If additional duct work is added externally to the Rittal cabinet the pressure drop in the ducting must be calculated. Use the charts below to derate the frequency converter according to the pressure drop.

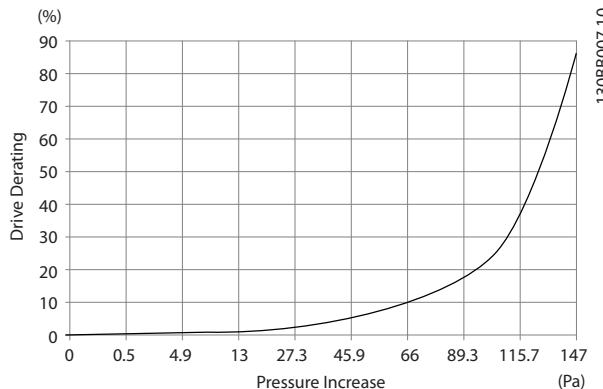

Illustration 4.14 D Frame Derating vs. Pressure Change
Drive Air Flow: 450 cfm (765 m³/h)

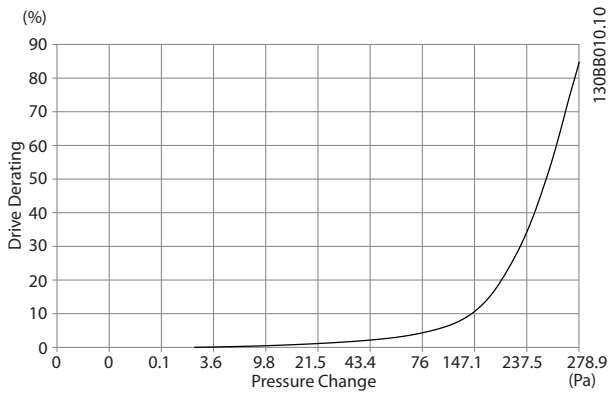

Illustration 4.15 E Frame Derating vs. Pressure Change 250-315 KW

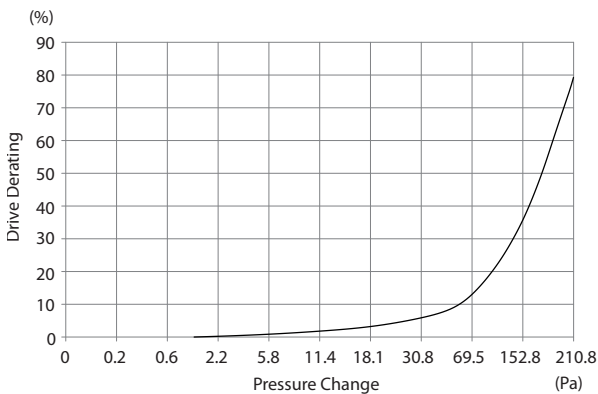

Illustration 4.16 E Frame Derating vs. Pressure Change 355-450 KW

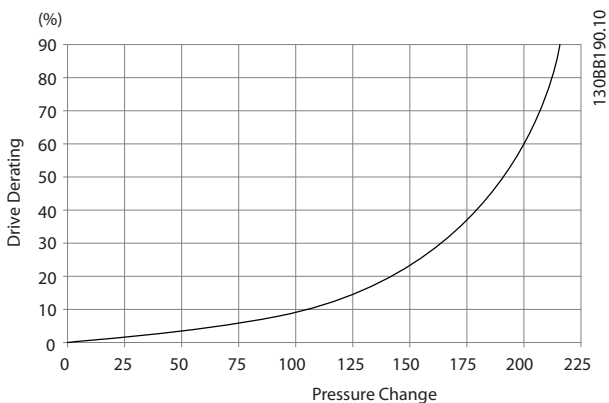

Illustration 4.17 F Frame Derating vs. Pressure Change
Drive Air Flow: 580 cfm (985 m³/h)

4.3.7 Gland/Conduit Entry - IP21 (NEMA 1) and IP54 (NEMA12)

Cables are connected through the gland plate from the bottom. Remove the plate and plan where to place the entry for the glands or conduits. Prepare holes in the marked area on the drawing.

NOTE

The gland plate must be fitted to the frequency converter to ensure the specified protection degree, as well as ensuring proper cooling of the unit. If the gland plate is not mounted, the frequency converter may trip on Alarm 69, Pwr. Card Temp

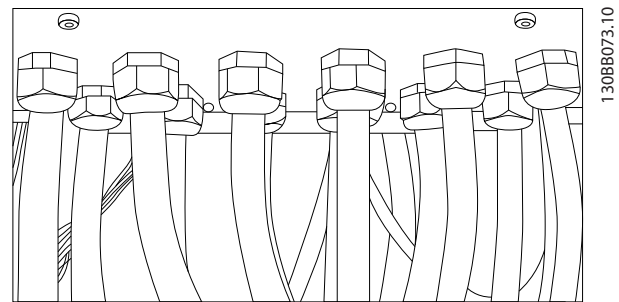

Illustration 4.18 Example of Proper Installation of the Gland Plate.

4

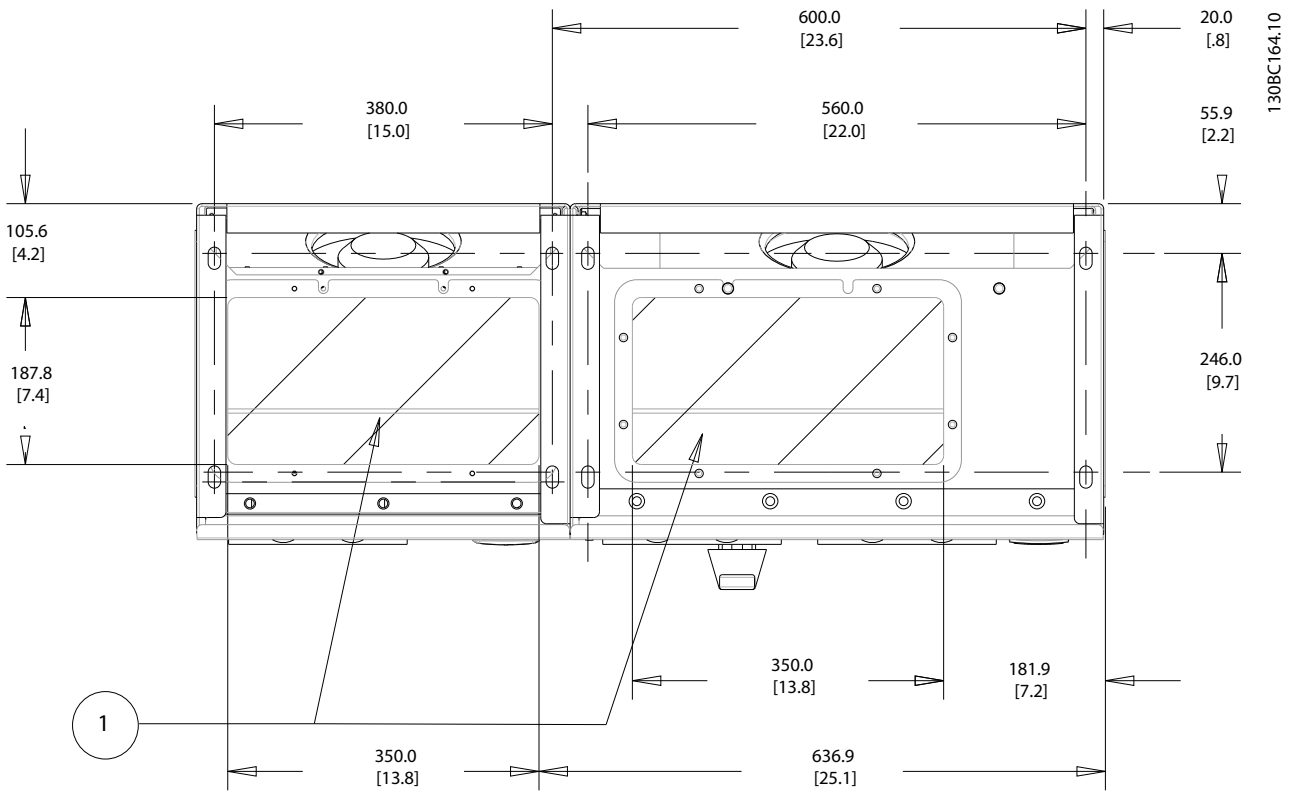

Illustration 4.19 Frame Size D13

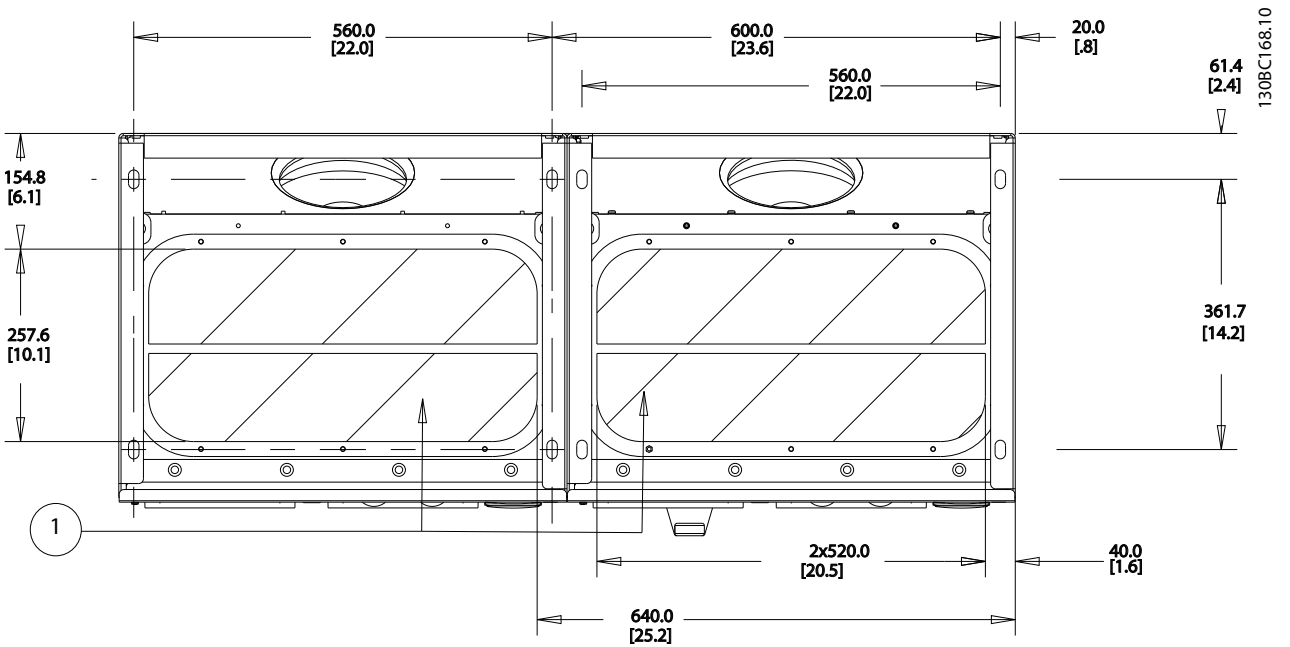
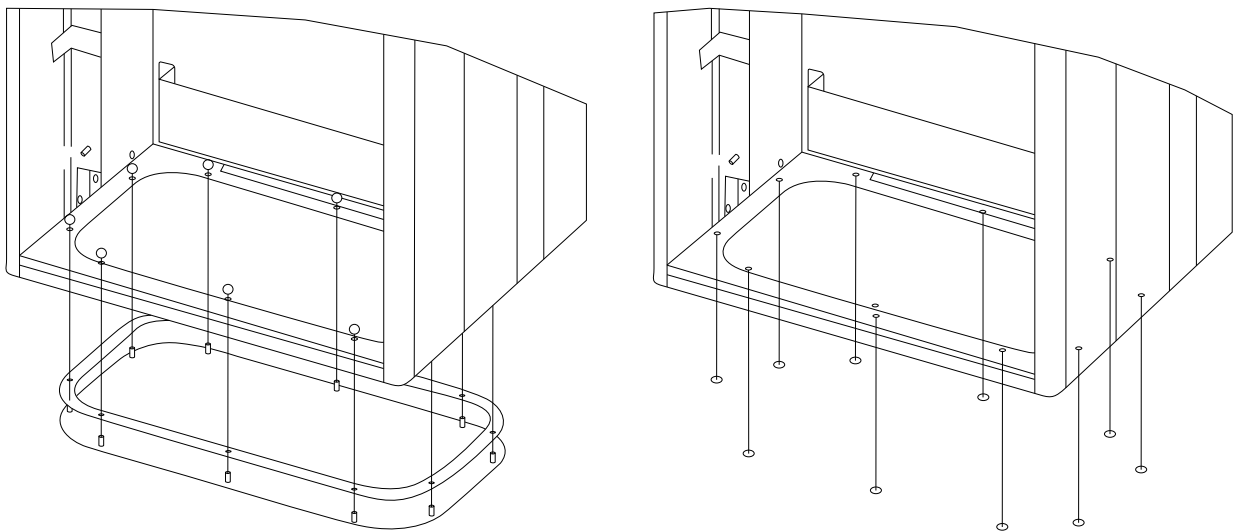

Illustration 4.20 Frame Size E9



176FA269.10

4

Illustration 4.21 Mounting of Bottom Plate, E9 Frame Size

The bottom plate of the E frame can be mounted from either in- or outside of the enclosure, allowing flexibility in the installation process, i.e. if mounted from the bottom

the glands and cables can be mounted before the frequency converter is placed on the pedestal.

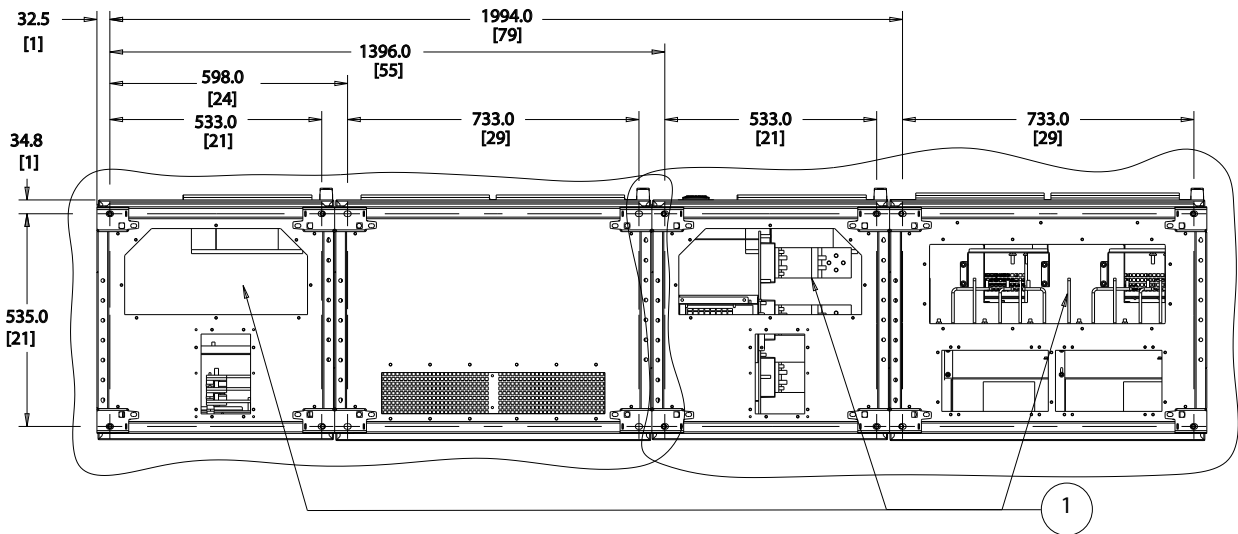

130BC173.10

Illustration 4.22 Frame Size F18

Cable entries viewed from the bottom of the frequency converter

- 1) Mains cable connection
- 2) Motor cable connection

4

4.3.8 IP21 Drip Shield Installation (Frame Size D)

To comply with the IP21 rating, a separate drip shield is to be installed as explained below

1. Remove the two front screws
2. Insert the drip shield and replace screws
3. Torque the screws to 5.6 Nm (50 in-lbs)

NOTE

Drip shield is necessary on both filter and drive section.

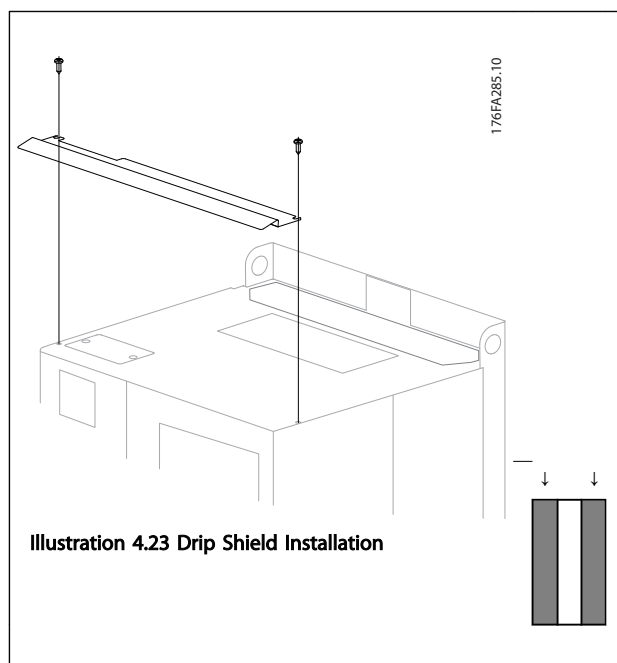

Illustration 4.23 Drip Shield Installation

Table 4.11

	380-480 V 380-500 V	Fuses	Disconnect Fuses	RFI	RFI Fuses	RFI Disconnect Fuses
D13		176F8443	176F8441	176F8445	176F8449	176F8447
E9	FC 102/202: 315 kW FC 302: 250 kW	176F0253	176F0255	176F0257	176F0258	176F0260
	FC 102/202: 355-450 kW FC 302: 315-400 kW	176F0254	176F0256	176F0257	176F0259	176F0262

Table 4.12

NOTE

For further information, please see the Instruction Sheet, 175R5795

4.4 Field Installation of Options

4.4.1 Installation of Input Plate Options

This section is for the field installation of input option kits available for frequency converters in all D and E frames. Do not attempt to remove RFI filters from input plates. Damage may occur to RFI filters if they are removed from the input plate.

NOTE

Where RFI filters are available, there are two different type of RFI filters depending on the input plate combination and the RFI filters interchangeable. Field installable kits in certain cases are the same for all voltages.

4.4.2 Installation of Mains Shield for Frequency Converters

The mains shield is for installation with D and E frames and satisfy BG-4 requirements.

Ordering numbers:

D frames: 176F0799

E frames: 176F1851

NOTE

For further information, see the Instruction Sheet, 175R5923

4.5 Frame Size F Panel Options

Space heaters and thermostat

Mounted on the cabinet interior of frame size F frequency converters, space heaters controlled via automatic thermostat help control humidity inside the enclosure, extending the lifetime of frequency converter components in damp environments. The thermostat default settings turn on the heaters at 10 °C (50 °F) and turn them off at 15.6 °C (60 °F).

Cabinet light with power outlet

A light mounted on the cabinet interior of frame size F frequency converters increase visibility during servicing and maintenance. The housing of the light includes a power outlet for temporarily powering tools or other devices, available in two voltages:

- 230 V, 50 Hz, 2.5 A, CE/ENEC
- 120 V, 60 Hz, 5 A, UL/cUL

Transformer tap set-up

If the Cabinet Light & Outlet and/or the Space Heaters & Thermostat are installed, transformer T1 requires the taps to be set to the proper input voltage. A 380-480/500 V 380-480 V frequency converter will initially be set to the 525 V tap and a 525-690 V frequency converter will be set to the 690 V tap to ensure no over-voltage of secondary equipment occurs if the tap is not changed before it is applied. See Table 4.13 to set the proper tap at terminal T1 located in the rectifier cabinet. For location in the frequency converter, see Illustration 4.29.

Input Voltage Range	Tap to Select
380 V-440 V	400 V
441 V-490 V	460 V

Table 4.13

NAMUR Terminals

NAMUR is an international association of automation technology users in the process industries, primarily chemical and pharmaceutical industries in Germany. Selection of this option provides terminals organized and labeled to the specifications of the NAMUR standard for

frequency converter input and output terminals. This requires MCB 112 PTC Thermistor Card and MCB 113 Extended Relay Card.

RCD (Residual Current Device)

Uses the core balance method to monitor ground fault currents in grounded and high-resistance grounded systems (TN and TT systems in IEC terminology). There is a pre-warning (50% of main alarm set-point) and a main alarm set-point. Associated with each set-point is an SPDT alarm relay for external use. Requires an external “window-type” current transformer (supplied and installed by customer).

- Integrated into the frequency converter’s safe-stop circuit
- IEC 60755 Type B device monitors AC, pulsed DC, and pure DC ground fault currents
- LED bar graph indicator of the ground fault current level from 10–100% of the set-point
- Fault memory
- [Test/Reset] key

Insulation Resistance Monitor (IRM)

Monitors the insulation resistance in ungrounded systems (IT systems in IEC terminology) between the system phase conductors and ground. There is an ohmic pre-warning and a main alarm set-point for the insulation level. Associated with each set-point is an SPDT alarm relay for external use.

NOTE

Only one insulation resistance monitor can be connected to each ungrounded (IT) system.

- Integrated into the frequency converter’s safe-stop circuit
- LCD display of the ohmic value of the insulation resistance
- Fault Memory
- [Info], [Test], and [Reset] keys

IEC emergency stop with Pilz safety relay

Includes a redundant 4-wire emergency-stop push-button mounted on the front of the enclosure and a Pilz relay that monitors it in conjunction with the frequency converter’s safe-stop circuit and the mains contactor located in the options cabinet.

Manual motor starters

Provide 3-phase power for electric blowers often required for larger motors. Power for the starters is provided from the load side of any supplied contactor, circuit breaker, or disconnect switch. Power is fused before each motor starter, and is off when the incoming power to the frequency converter is off. Up to two starters are allowed (one if a 30 A, fuse-protected circuit is ordered). Integrated into the frequency converter’s safe-stop circuit.

Unit features include:

- Operation switch (on/off)
- Short-circuit and overload protection with test function
- Manual reset function

30 A, fuse-protected terminals

- 3-phase power matching incoming mains voltage for powering auxiliary customer equipment
- Not available if two manual motor starters are selected
- Terminals are off when the incoming power to the frequency converter is off
- Power for the fused protected terminals will be provided from the load side of any supplied contactor, circuit breaker, or disconnect switch.

24 V DC power supply

- 5 A, 120 W, 24 V DC
- Protected against output over-current, overload, short circuits, and over-temperature
- For powering customer-supplied accessory devices such as sensors, PLC I/O, contactors, temperature probes, indicator lights, and/or other electronic hardware
- Diagnostics include a dry DC-ok contact, a green DC-ok LED, and a red overload LED

External temperature monitoring

Designed for monitoring temperatures of external system components, such as the motor windings and/or bearings. Includes eight universal input modules plus two dedicated thermistor input modules. All ten modules are integrated into the frequency converter's safe-stop circuit and can be monitored via a fieldbus network (requires the purchase of a separate module/bus coupler).

Universal inputs (8)

Signal types:

- RTD inputs (including Pt100), 3-wire or 4-wire
- Thermocouple
- Analog current or analog voltage

Additional features:

- One universal output, configurable for analog voltage or analog current
- Two output relays (N.O.)
- Dual-line LC display and LED diagnostics
- Sensor lead wire break, short-circuit, and incorrect polarity detection
- Interface set-up software

Dedicated thermistor inputs (2)

Features:

- Each module capable of monitoring up to six thermistors in series
- Fault diagnostics for wire breakage or short-circuits of sensor leads
- ATEX/UL/CSA certification
- A third thermistor input can be provided by the PTC Thermistor Option Card MCB 112, if necessary

4.6 Electrical Installation

4.6.1 Power Connections

Cabling and Fusing

NOTE

Cables General

All cabling must comply with national and local regulations on cable cross-sections and ambient temperature. UL applications require 75 °C copper conductors. 75 and 90 °C copper conductors are thermally acceptable for the frequency converter to use in non UL applications.

The power cable connections are situated as shown below. Dimensioning of cable cross section must be done in accordance with the current ratings and local legislation. See 8 General Specifications for details.

For protection of the frequency converter, the recommended fuses must be used or the unit must be with built-in fuses. Recommended fuses can be seen in 4.6.15 Fuse Specifications. Always ensure that proper fusing is made according to local regulation.

The mains connection is fitted to the mains switch if this is included.

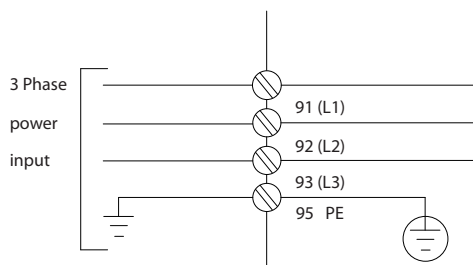

Illustration 4.23

NOTE

To comply with EMC emission specifications, screened/ armoured cables are recommended. If an unscreened/ unarmoured cable is used, see 4.6.13 Power and Control Wiring for Unscreened Cables.

See 8 General Specifications for correct dimensioning of motor cable cross-section and length.

Screening of cables

Avoid installation with twisted screen ends (pigtailed). They spoil the screening effect at higher frequencies. If it is necessary to break the screen to install a motor isolator or motor contactor, the screen must be continued at the lowest possible HF impedance.

Connect the motor cable screen to both the de-coupling plate of the frequency converter and to the metal housing of the motor.

Make the screen connections with the largest possible surface area (cable clamp). This is done by using the supplied installation devices within the frequency converter.

Cable-length and cross-section

The frequency converter has been EMC tested with a given length of cable. Keep the motor cable as short as possible to reduce the noise level and leakage currents.

Switching frequency

When frequency converters are used together with Sine-wave filters to reduce the acoustic noise from a motor, the switching frequency must be set according to the instruction in 14-01 Switching Frequency.

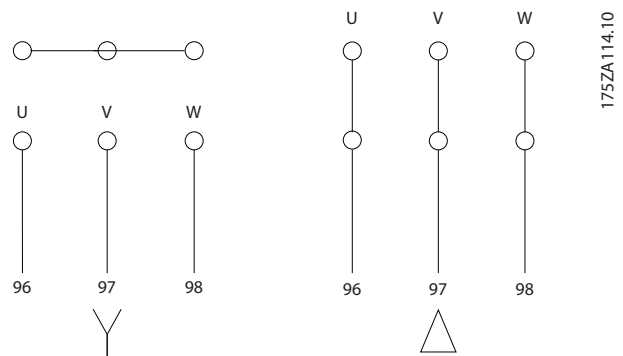

Illustration 4.24

Term. no.	96	97	98	99	
	U	V	W	PE ¹⁾	Motor voltage 0-100% of mains voltage. 3 wires out of motor
	U1	V1	W1	PE ¹⁾	Delta-connected
	W2	U2	V2		6 wires out of motor
	U1	V1	W1	PE ¹⁾	Star-connected U2, V2, W2 U2, V2 and W2 to be interconnected separately.

Table 4.14

¹⁾ Protected Earth Connection

NOTE

In motors without phase insulation paper or other insulation reinforcement suitable for operation with voltage supply (such as a frequency converter), fit a Sine-wave filter on the output of the frequency converter.

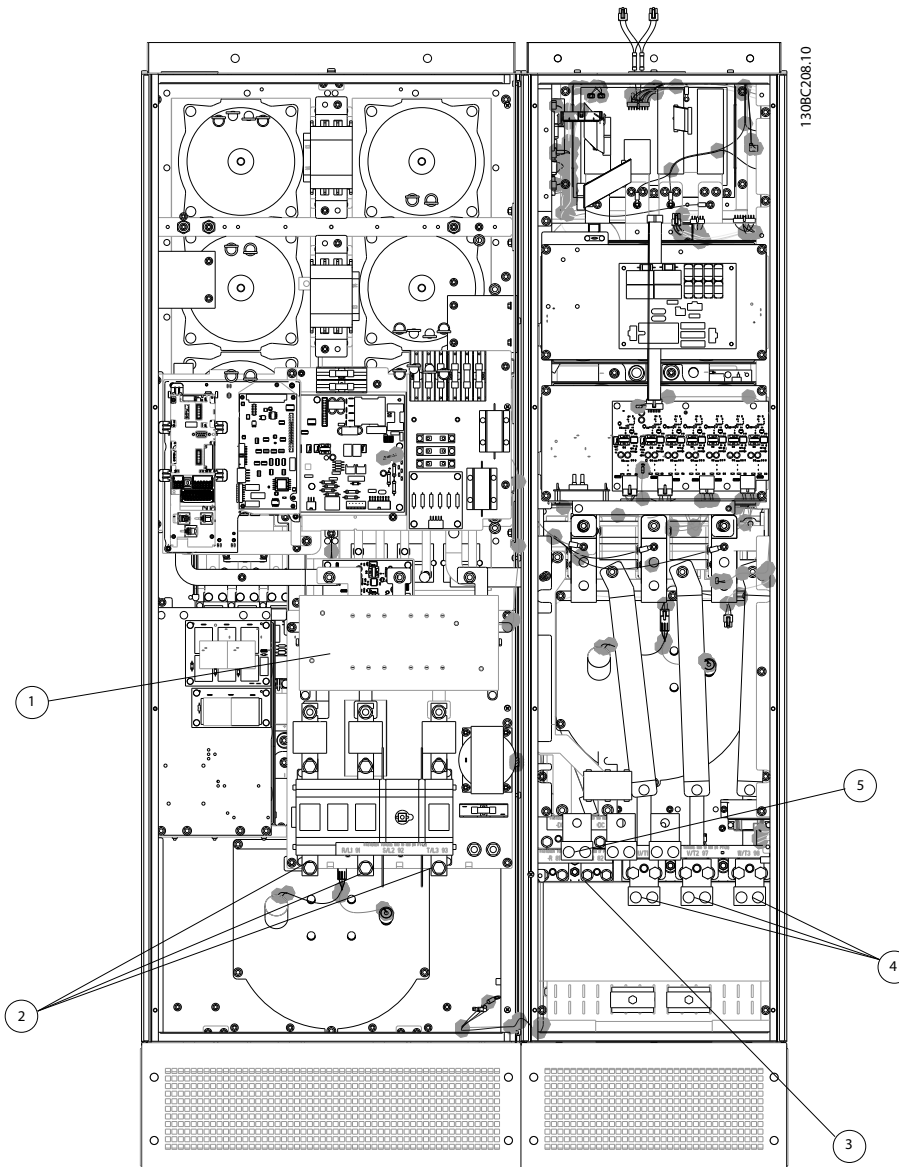
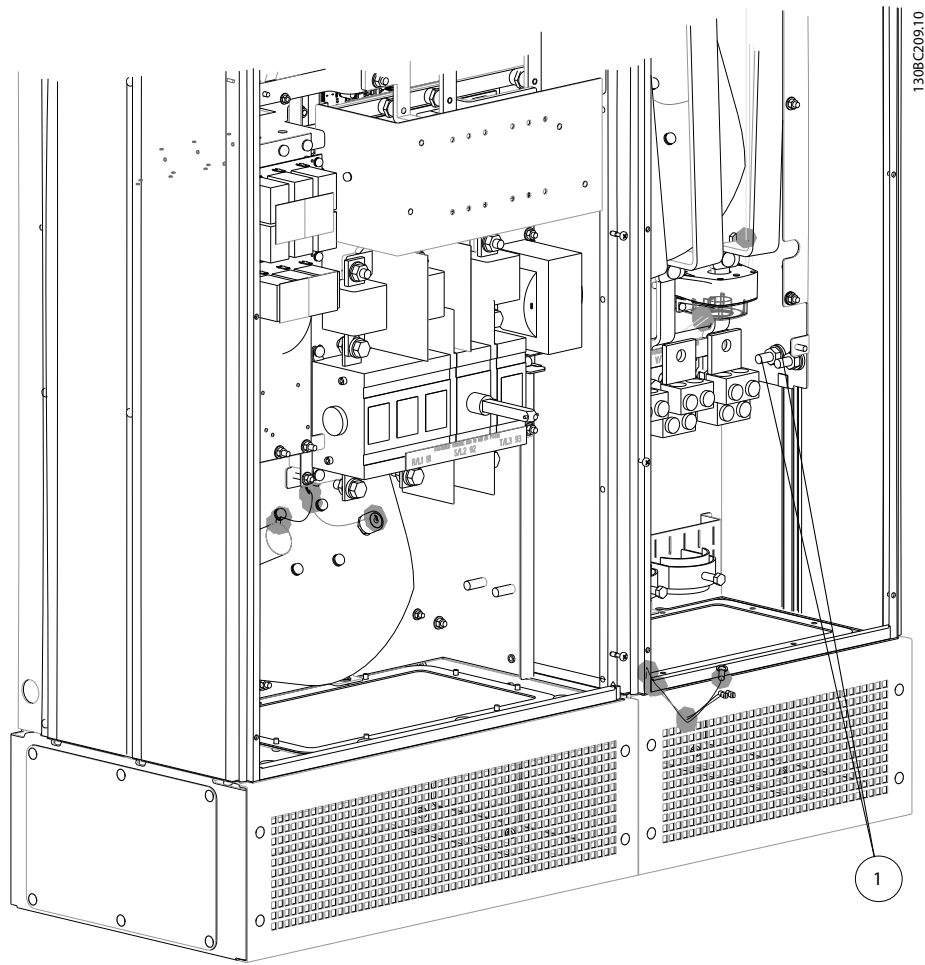

Illustration 4.25 Frame Size D13

1) RFI	4) Motor
2) Line	U V W
R S T	96 97 98
L1 L2 L3	T1 T2 T3
3) Brake option	5) Load sharing option
-R +R	-DC +DC
81 82	88 89
	6) AUX Fan
	100 101 102 103
	L1 L2 L1 L2

Table 4.15



4

Illustration 4.26 Position of Earth Terminals

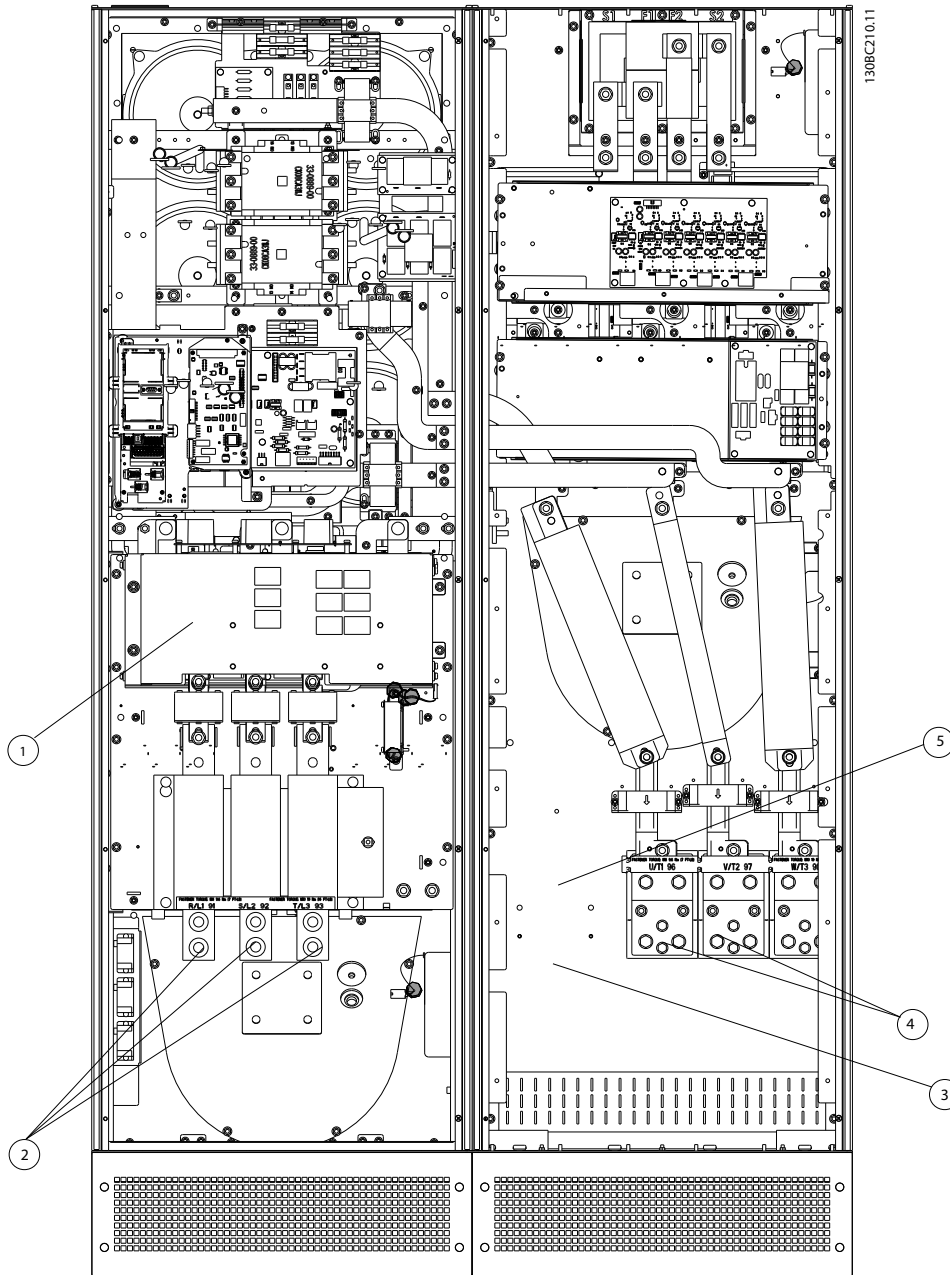
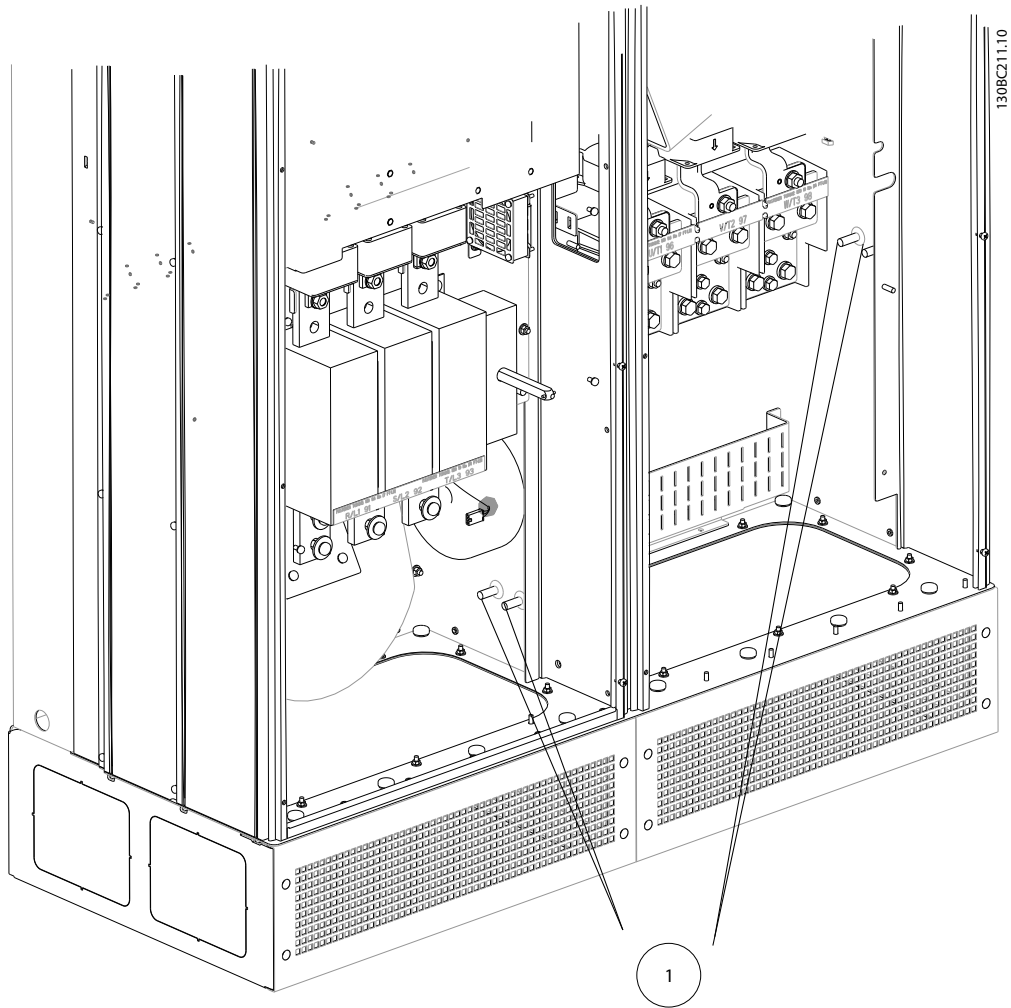

Illustration 4.27 Frame Size E9

1) RFI				4) Motor			
2) Line				U	V	W	
R	S	T		96	97	98	
L1	L2	L3		T1	T2	T3	
3) Brake option				5) Load sharing option			
-R	+R			-DC	+DC		
81	82			88	89		
				6) AUX Fan			
				100	101	102	103
				L1	L2	L1	L2

Table 4.16



4

Illustration 4.28 Position of Earth Terminals

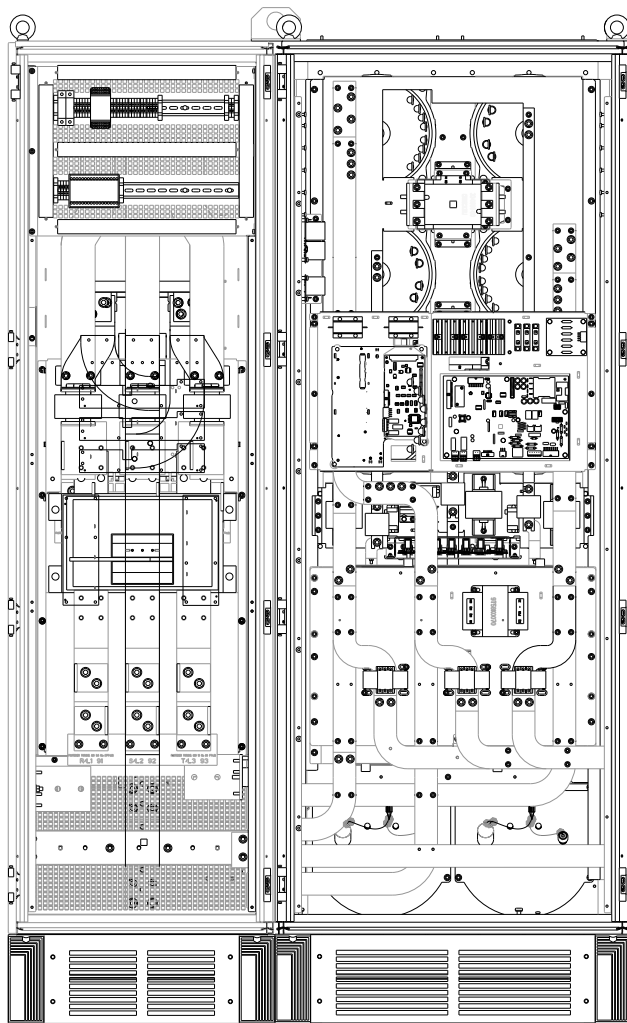

13.0Bx443

Illustration 4.29 Active Filter, Frame Size F18

Sections shown

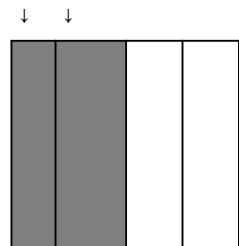

Table 4.17

1)	Line			
	R	S	T	
	L1	L2	L3	
2)	Bus bars to rectifier section of frequency converter			
3)	Fuse block			

Table 4.18

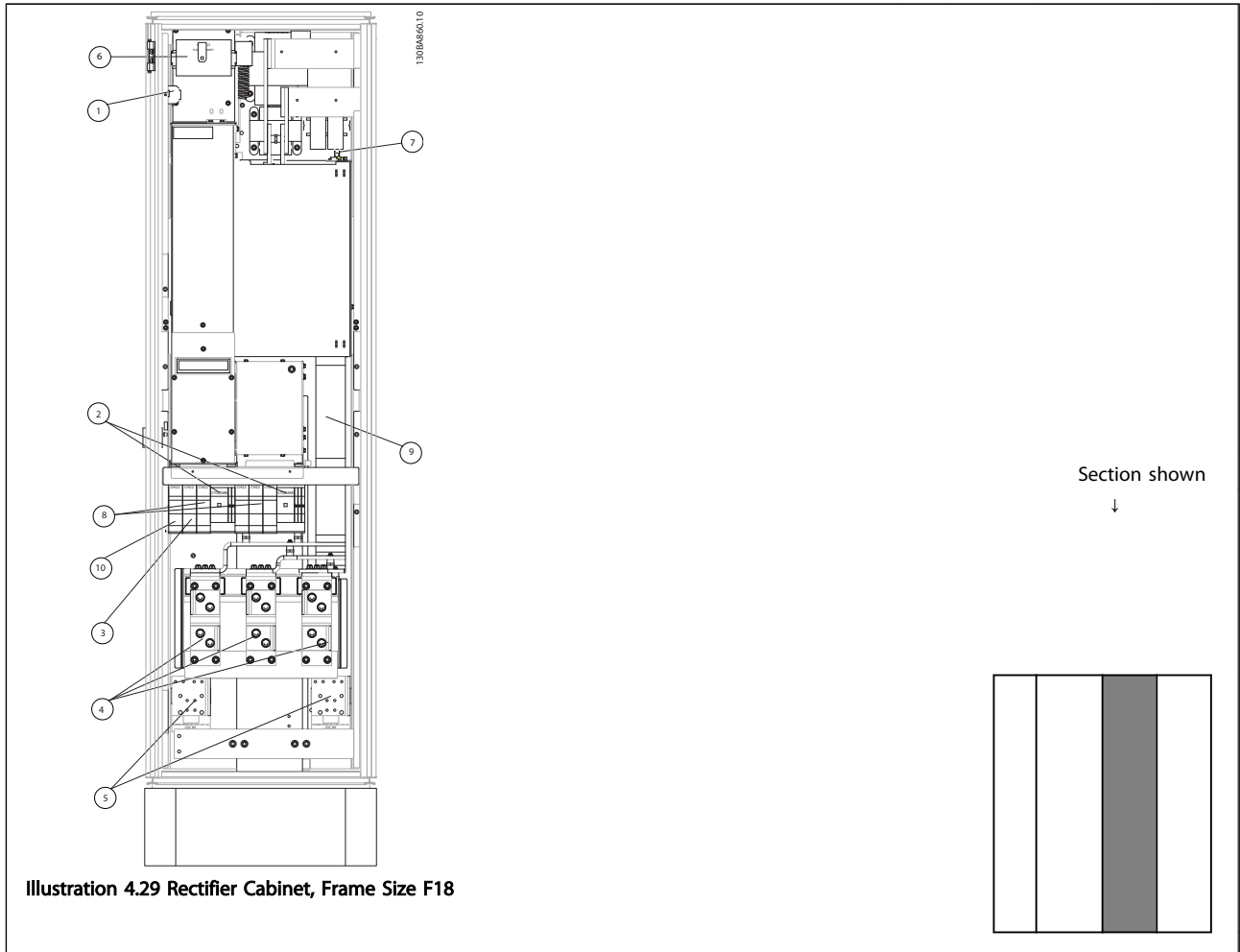

Illustration 4.29 Rectifier Cabinet, Frame Size F18

Table 4.19

1) 24 V DC, 5 A T1 Output Taps Temp Switch 106 104 105	5) Loadsharing -DC +DC 88 89
2) Manual Motor Starters	6) Control Transformer Fuses (2 or 4 pieces). See 4.6.14 Fuses for part numbers
3) 30 A Fuse Protected Power Terminals	7) SMPS Fuse. See 4.6.14 Fuses for part numbers
4) Connection point to filter R S T L1 L2 L3	8) Manual Motor Controller fuses (3 or 6 pieces). See 4.6.14 Fuses for part numbers
	9) Line Fuses, F1 and F2 frame (3 pieces). See 4.6.14 Fuses for part numbers
	10) 30 Amp Fuse Protected Power fuses

Table 4.20

4

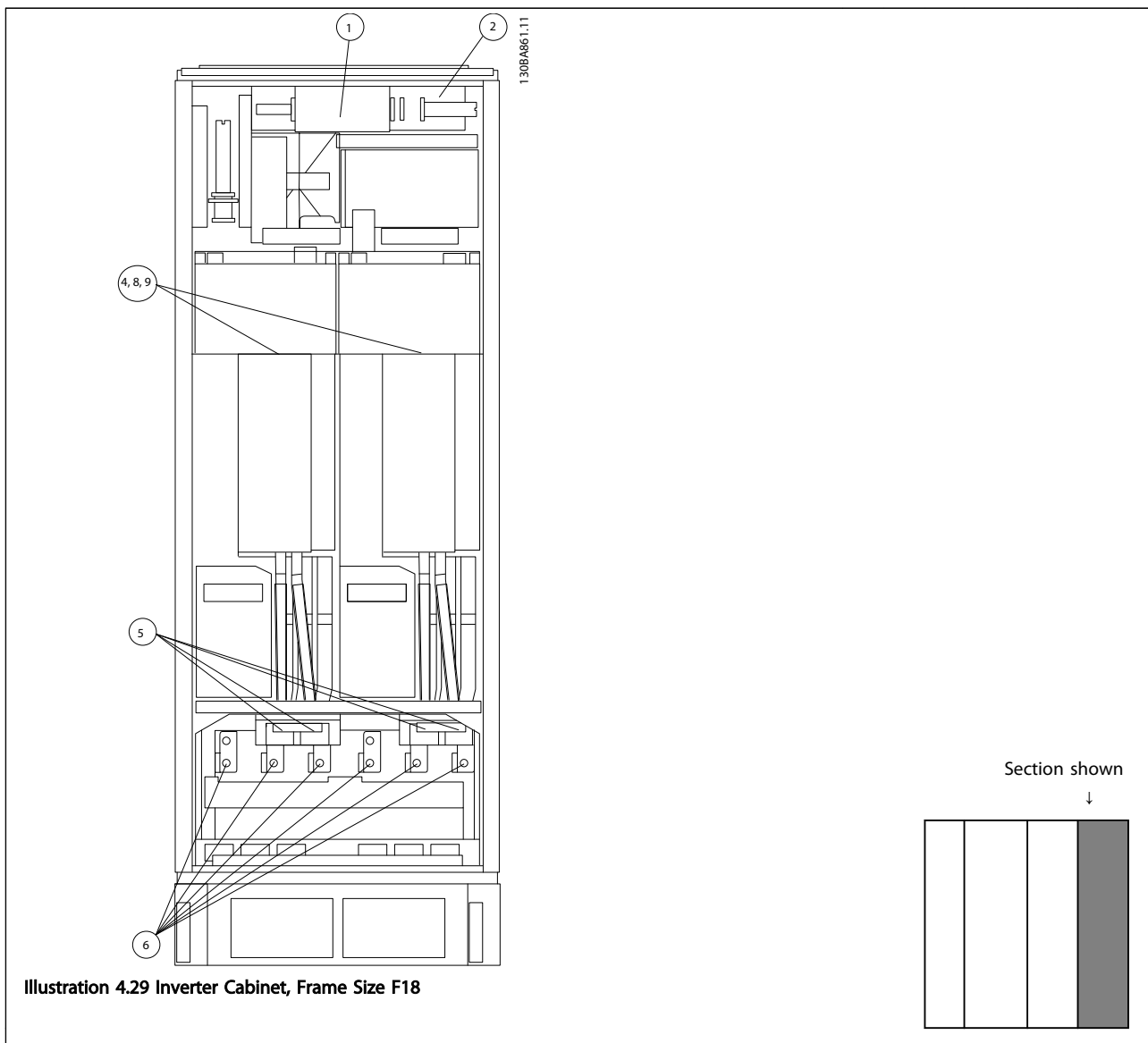

Illustration 4.29 Inverter Cabinet, Frame Size F18

Table 4.21

1) External Temperature Monitoring	6) Motor
2) AUX Relay	U V W
01 02 03	96 97 98
04 05 06	T1 T2 T3
3) NAMUR	7) NAMUR Fuse. See 4.6.14 Fuses for part numbers
4) AUX Fan	8) Fan Fuses. See 4.6.14 Fuses for part numbers
100 101 102 103	9) SMPS Fuses. See 4.6.14 Fuses for part numbers
L1 L2 L1 L2	
5) Brake	
-R +R	
81 82	

Table 4.22

4.6.2 Earthing

The following basic issues need to be considered when installing a frequency converter, so as to obtain electro-magnetic compatibility (EMC).

- Safety earthing: Note that the frequency converter has a high leakage current and must be earthed appropriately for safety reasons. Apply local safety regulations.
- High-frequency earthing: Keep the earth wire connections as short as possible.

Connect the different earth systems at the lowest possible conductor impedance. The lowest possible conductor impedance is obtained by keeping the conductor as short as possible and by using the greatest possible surface area. The metal cabinets of the different devices are mounted on the cabinet rear plate using the lowest possible HF impedance. This avoids having different HF voltages for the individual devices and avoids the risk of radio interference currents running in connection cables that may be used between the devices. The radio interference will have been reduced.

In order to obtain a low HF impedance, use the fastening bolts of the devices as HF connection to the rear plate. It is necessary to remove insulating paint or similar from the fastening points.

4.6.3 Extra Protection (RCD)

ELCB relays, multiple protective earthing or earthing can be used as extra protection, provided that local safety regulations are complied with.

In the case of an earth fault, a DC component may develop in the fault current.

If ELCB relays are used, local regulations must be observed. Relays must be suitable for protection of 3-phase equipment with a bridge rectifier and for a brief discharge on power-up.

See also *Special Conditions* in the Design Guide, MG33BXYY.

4.6.4 RFI Switch

Mains supply isolated from earth

If the frequency converter is supplied from an isolated mains source (IT mains, floating delta and grounded delta) or TT/TN-S mains with grounded leg, the RFI switch is recommended to be turned off (OFF) via 14-50 RFI Filter on the frequency converter and 14-50 RFI Filter on the filter. For further reference, see IEC 364-3. In case optimum EMC performance is needed, parallel motors are connected or the motor cable length is above 25 m, it is recommended to set 14-50 RFI Filter to [ON].

In OFF, the internal RFI capacities (filter capacitors) between the chassis and the intermediate circuit are cut off to avoid damage to the intermediate circuit and to reduce the earth capacity currents (according to IEC 61800-3).

Also refer to the application note *VLT on IT mains, MN90CX02*. It is important to use isolation monitors that are capable for use together with power electronics (IEC 61557-8).

4.6.5 Torque

When tightening all electrical connections it is very important to tighten with the correct torque. Too low or too high torque results in a bad electrical connection. Use a torque wrench to ensure correct torque.

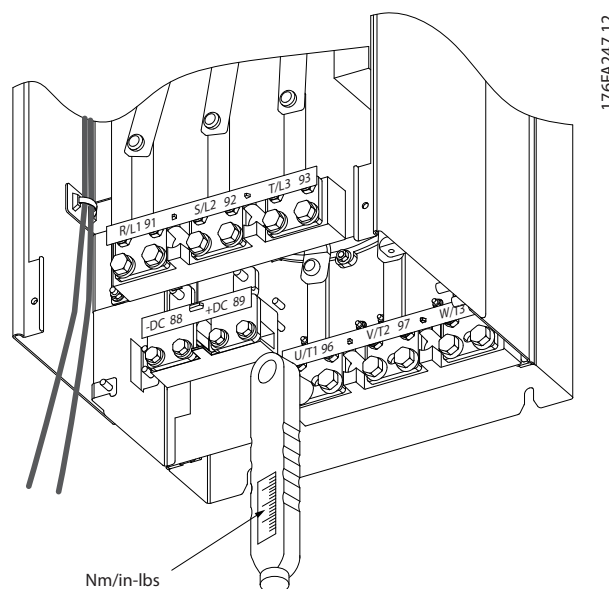
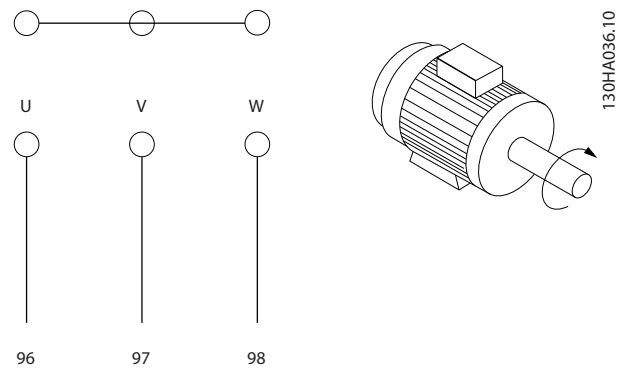

Illustration 4.29 Always Use a Torque Wrench to Tighten the Bolts.

Frame size	Terminal	Torque	Bolt size
D	Mains Motor	19-40 Nm (168-354 in-lbs)	M10
	Load sharing Brake	8.5-20.5 Nm (75-181 in-lbs)	M8
E	Mains Motor Load sharing	19-40 Nm (168-354 in-lbs)	M10
	Brake	8.5-20.5 Nm (75-181 in-lbs)	M8

Frame size	Terminal	Torque	Bolt size
F	Mains Motor	19-40 Nm (168-354 in-lbs)	M10
	Load sharing	19-40 Nm (168-354 in-lbs)	M10 M8 M8
	Brake Regen	8.5-20.5 Nm (75-181 in-lbs) 8.5-20.5 Nm (75-181 in-lbs)	

Table 4.23 Torque for Terminals



4.6.6 Shielded Cables

WARNING

Danfoss recommends to use shielded cables between the LCL filter and the AFE unit. Unshielded cables can be between transformer and LCL filter input side.

It is important that shielded and armoured cables are connected in a proper way to ensure the high EMC immunity and low emissions.

The connection can be made using either cable glands or clamps

- EMC cable glands: Generally available cable glands can be used to ensure an optimum EMC connection.
- EMC cable clamp: Clamps allowing easy connection are supplied with the frequency converter.

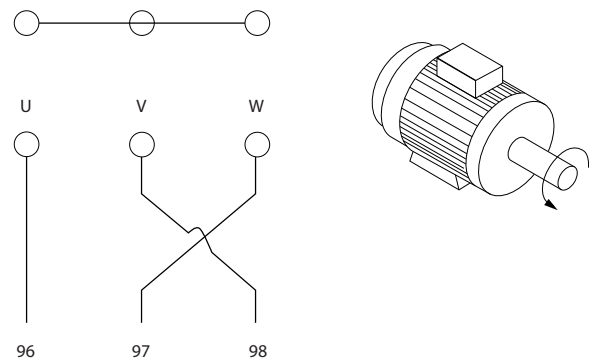

Illustration 4.30

The direction of rotation can be changed by switching two phases in the motor cable or by changing the setting of 4-10 Motor Speed Direction.

4.6.7 Motor Cable

The motor must be connected to terminals U/T1/96, V/T2/97, W/T3/98 located on the far right of the unit. Earth to terminal 99. All types of three-phase asynchronous standard motors can be used with a frequency converter unit. The factory setting is for clockwise rotation with the frequency converter output connected as follows:

Terminal No.	Function
96, 97, 98, 99	Mains U/T1, V/T2, W/T3 Earth

Table 4.24

- Terminal U/T1/96 connected to U-phase
- Terminal V/T2/97 connected to V-phase
- Terminal W/T3/98 connected to W-phase

Motor rotation check can be performed using 1-28 Motor Rotation Check and following the steps shown in the display.

F frame Requirements

Motor phase cable quantities must be multiples of 2, resulting in 2, 4, 6, or 8 (1 cable is not allowed) to obtain equal amount of wires attached to both inverter module terminals. The cables are required to be equal length within 10% between the inverter module terminals and the first common point of a phase. The recommended common point is the motor terminals.

Output junction box requirements

The length, minimum 2.5 m, and quantity of cables must be equal from each inverter module to the common terminal in the junction box.

NOTE

If a retrofit application requires unequal amount of wires per phase, consult the factory for requirements and documentation or use the top/bottom entry side cabinet option, instruction 177R0097.

4.6.8 Brake Cable Drives with Factory Installed Brake Chopper Option

(Only standard with letter B in position 18 of typecode).

The connection cable to the brake resistor must be screened and the max. length from frequency converter to the DC bar is limited to 25 m (82 ft).

Terminal No.	Function
81, 82	Brake resistor terminals

Table 4.25

The connection cable to the brake resistor must be screened. Use cable clamps to connect the screen to the conductive back plate at the frequency converter and to the metal cabinet of the brake resistor.

Size the brake cable cross-section to match the brake torque. See also *Brake Instructions, MI90FXYY* and *MI50SXYY* for further information regarding safe installation.

⚠ WARNING

Note that voltages up to 790 V DC, depending on the supply voltage, may occur on the terminals.

F Frame Requirements

The brake resistor(s) must be connected to the brake terminals in each inverter module.

4.6.9 Brake Resistor Temperature Switch

Frame size D-E-F

Torque: 0.5-0.6 Nm (5 in-lbs)
Screw size: M3

This input can be used to monitor the temperature of an externally connected brake resistor. If the connection between 104 and 106 is removed, the frequency converter will trip on warning/ alarm 27, "Brake IGBT".

A KLIXON switch must be installed that is 'normally closed' in series with the existing connection on either 106 or 104. Any connection to this terminal must be double insulated to high voltage to maintain PELV.

Normally closed: 104-106 (factory installed jumper).

Terminal No.	Function
106, 104, 105	Brake resistor temperature switch.

Table 4.26

⚠ CAUTION

If the temperature of the brake resistor gets too high and the thermal switch drops out, the frequency converter will stop braking. The motor will start coasting.

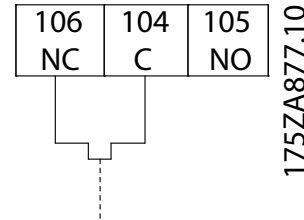

Illustration 4.31

4.6.10 Load Sharing

Terminal No.	Function
88, 89	Loadsharing

Table 4.27

The connection cable must be screened and the max. length from the frequency converter to the DC bar is limited to 25 m (82 ft).

Load sharing enables linking of the DC intermediate circuits of several frequency converters.

⚠ WARNING

Note that voltages up to 1099 V DC may occur on the terminals.

Load Sharing calls for extra equipment and safety considerations. For further information, see load sharing Instructions MI50NXYY.

⚠ WARNING

Note that mains disconnect may not isolate the frequency converter due to DC link connection

4.6.11 Mains Connection

Mains must be connected to terminals 91, 92 and 93 located on the far left of the unit. Earth is connected to the terminal to the right of terminal 93.

Terminal No.	Function
91, 92, 93	Mains R/L1, S/L2, T/L3
94	Earth

Table 4.28

NOTE

Check the name plate to ensure that the mains voltage of the frequency converter matches the power supply of the plant.

Ensure that the power supply can supply the necessary current to the frequency converter.

If the unit is without built-in fuses, ensure that the appropriate fuses have the correct current rating.

4.6.12 External Fan Supply

In case the frequency converter is supplied by DC or if the fan must run independently of the power supply, an external power supply can be applied. The connection is made on the power card.

Terminal No.	Function
100, 101	Auxiliary supply S, T
102, 103	Internal supply S, T

Table 4.29

The connector located on the power card provides the connection of line voltage for the cooling fans. The fans are connected from factory to be supplied from a common AC line (jumpers between 100-102 and 101-103). If external supply is needed, the jumpers are removed and the supply is connected to terminals 100 and 101. A 5 Amp fuse should be used for protection. In UL applications this should be LittleFuse KLK-5 or equivalent.

4.6.13 Power and Control Wiring for Unscreened Cables

⚠ WARNING

Induced Voltage!

Run motor cables from multiple drives separately. Induced voltage from output motor cables run together can charge equipment capacitors even with the equipment turned off and locked out. Failure to run output cables separately could result in death or serious injury.

⚠ WARNING

Run drive input power, motor wiring, and control wiring in three separate metallic conduits or raceways for high frequency noise isolation. Failure to isolate power, motor, and control wiring could result in less than optimum controller and associated equipment performance.

Because the power wiring carries high frequency electrical pulses, it is important that input power and motor power are run in separate conduit. If the incoming power wiring

is run in the same conduit as the motor wiring, these pulses can couple electrical noise back onto the building power grid. Control wiring should always be isolated from the high voltage power wiring.

When screened/armoured cable is not used, at least three separate conduits must be connected to the panel option.

- Power wiring into the enclosure
- Power wiring from the enclosure to the motor
- Control wiring

4.6.14 Fuses

It is recommended to use fuses and/or circuit breakers on the supply side as protection in case of component break-down inside the frequency converter (first fault).

NOTE

This is mandatory in order to ensure compliance with IEC 60364 for CE or NEC 2009 for UL.

⚠ WARNING

Personnel and property must be protected against the consequence of component break-down internally in the frequency converter.

Branch circuit protection

In order to protect the installation against electrical and fire hazard, all branch circuits in an installation, switch gear, machines etc., must be protected against short-circuit and over-current according to national/international regulations.

NOTE

The recommendations given do not cover Branch circuit protection for UL.

Short-circuit protection:

Danfoss recommends using the fuses/circuit breakers mentioned below to protect service personnel and property in case of component break-down in the frequency converter.

Non UL compliance

If UL/cUL is not to be complied with, use the following fuses, which will ensure compliance with EN50178:

P160-P250	380-480 V	type gG
P315-P450	380-480 V	type gR

Table 4.30

4.6.15 Fuse Specifications

UL compliance

380-480 V, frame sizes D, E and F

The fuses below are suitable for use on a circuit capable of delivering 100,000 Arms (symmetrical), 240 V, or 480 V, or 500 V, or 600 V depending on the frequency converter

voltage rating. With the proper fusing the frequency converter Short Circuit Current Rating (SCCR) is 100,000 Arms.

Size/ Type	Bussmann E1958 JFHR2**	Bussmann E4273 T/JDDZ**	SIBA E180276 JFHR2	Littelfuse E91611 JFHR2**	Ferraz- Shawmut E60314 JFHR2**	Bussmann E4274 H/JDDZ**	Bussmann E125085 JFHR2*	Internal Option Bussmann
P160	FWH- 400	JJS- 400	2061032.40	L50S-400	A50-P400	NOS- 400	170M4012	170M4016
P200	FWH- 500	JJS- 500	2061032.50	L50S-500	A50-P500	NOS- 500	170M4014	170M4016
P250	FWH- 600	JJS- 600	2062032.63	L50S-600	A50-P600	NOS- 600	170M4016	170M4016

Table 4.31 Frame size D, Line Fuses, 380-480 V

Size/Type	Bussmann PN*	Rating	Ferraz	Siba
P315	170M4017	700 A, 700 V	6.9URD31D08A0700	20 610 32.700
P355	170M6013	900 A, 700 V	6.9URD33D08A0900	20 630 32.900
P400	170M6013	900 A, 700 V	6.9URD33D08A0900	20 630 32.900
P450	170M6013	900 A, 700 V	6.9URD33D08A0900	20 630 32.900

Table 4.32 Frame size E, Line Fuses, 380-480 V

Size/Type	Bussmann PN*	Rating	Siba	Internal Bussmann Option
P500	170M7081	1600 A, 700 V	20 695 32.1600	170M7082
P560	170M7081	1600 A, 700 V	20 695 32.1600	170M7082
P630	170M7082	2000 A, 700 V	20 695 32.2000	170M7082
P710	170M7082	2000 A, 700 V	20 695 32.2000	170M7082

Table 4.33 Frame size F, Line Fuses, 380-480 V

Size/Type	Bussmann PN*	Rating	Siba
P500	170M8611	1100 A, 1000 V	20 781 32.1000
P560	170M8611	1100 A, 1000 V	20 781 32.1000
P630	170M6467	1400 A, 700 V	20 681 32.1400
P710	170M6467	1400 A, 700 V	20 681 32.1400

Table 4.34 Frame Size F, Inverter module DC Link Fuses, 380-480 V

*170M fuses from Bussmann shown use the -/80 visual indicator, - TN/80 Type T, -/110 or TN/110 Type T indicator fuses of the same size and amperage may be substituted for external use

**Any minimum 500 V UL listed fuse with associated current rating may be used to meet UL requirements.

Supplementary fuses

Frame size	Bussmann PN*	Rating
D, E and F	KTK-4	4 A, 600 V

Table 4.35 SMPS Fuse

Size/Type	Bussmann PN*	Littelfuse	Rating
P160-P315, 380-480 V	KTK-4		4 A, 600 V
P355-P710, 380-480 V		KLK-15	15A, 600 V

Table 4.36 Fan Fuses

Size/Type		Bussmann PN*	Rating	Alternative Fuses
P500-P710, 380-480 V	2.5-4.0 A	LPJ-6 SP or SPI	6 A, 600 V	Any listed Class J Dual Element, Time Delay, 6A
P500-P710, 380-480 V	4.0-6.3 A	LPJ-10 SP or SPI	10 A, 600 V	Any listed Class J Dual Element, Time Delay, 10 A
P500-P710, 380-480 V	6.3 - 10 A	LPJ-15 SP or SPI	15 A, 600 V	Any listed Class J Dual Element, Time Delay, 15 A
P500-P710, 380-480 V	10 - 16 A	LPJ-25 SP or SPI	25 A, 600 V	Any listed Class J Dual Element, Time Delay, 25 A

Table 4.37 Manual Motor Controller Fuses

Frame size	Bussmann PN*	Rating	Alternative Fuses
F	LPJ-30 SP or SPI	30 A, 600 V	Any listed Class J Dual Element, Time Delay, 30 A

Table 4.38 30 A Fuse Protected Terminal Fuse

Frame size	Bussmann PN*	Rating	Alternative Fuses
D	LP-CC-8/10	0.8A, 600V	Any listed Class CC, 0.8A
E	LP-CC-1 1/2	1.5A, 600V	Any listed Class CC, 1.5A
F	LPJ-6 SP or SPI	6 A, 600 V	Any listed Class J Dual Element, Time Delay, 6 A

Table 4.39 Control Transformer Fuse

Frame size	Bussmann PN*	Rating
F	GMC-800MA	800 mA, 250 V

Table 4.40 NAMUR Fuse

Frame size	Bussmann PN*	Rating	Alternative Fuses
F	LP-CC-6	6 A, 600 V	Any listed Class CC, 6 A

Table 4.41 Safety Relay Coil Fuse with PILZ Relay

4.6.16 Mains Disconnectors

Frame size	Power & Voltage	Type
D	A190 380-480 V	ABB OETL-NF200A
E	A250 380-480 V	ABB OETL-NF400A
E	A310 380-480 V	ABB OETL-NF400A
E	A400 380-480 V	ABB OETL-NF800A

Table 4.42

4.6.17 F Frame Circuit Breakers

Frame size	Power & Voltage	Type
F	P500 380-480 V	Merlin Gerin NPJF36120U31AABSCYP
F	P560-P710 380-480 V	Merlin Gerin NRJF36200U31AABSCYP

Table 4.43

4.6.18 F Frame Mains Contactors

Frame size	Power & Voltage	Type
F	P500-P560 380-480 V	Eaton XTCE650N22A
F	P 630-P710 380-480 V	Eaton XTCEC14P22B

Table 4.44

4.6.19 Motor Insulation

For motor cable lengths \leq the maximum cable length listed in the following motor insulation ratings are recommended because the peak voltage can be up to twice the DC link voltage, 2.8 times the mains voltage, due to transmission line effects in the motor cable. If a motor has lower insulation rating it is recommended to use a dU/dt or sine wave filter.

Nominal Mains Voltage	Motor Insulation
$U_N \leq 420$ V	Standard $U_{LL} = 1300$ V
420 V < $U_N \leq 500$ V	Reinforced $U_{LL} = 1600$ V

Table 4.45

4.6.20 Motor Bearing Currents

It is recommended that motors of a rating 110 kW or higher operating via frequency converters should have NDE (Non-Drive End) insulated bearings installed to eliminate circulating bearing currents due to the physical size of the motor. To minimize DE (Drive End) bearing and shaft currents proper grounding of the frequency converter, motor, driven machine, and motor to the driven machine is required. Although failure due to bearing currents is low and dependent on many different items, for security of operation the following are mitigation strategies which can be implemented.

Standard mitigation strategies

1. Use an insulated bearing
2. Apply rigorous installation procedures
 - Ensure the motor and load motor are aligned
 - Strictly follow the EMC Installation guideline
 - Reinforce the PE so the high frequency impedance is lower in the PE than the input power leads
 - Provide a good high frequency connection between the motor and the frequency converter for instance by screened cable which has a 360° connection in the motor and the frequency converter

Make sure that the impedance from frequency converter to building ground is lower than the grounding impedance of the machine. This can be difficult for pumps- Make a direct earth connection between the motor and load motor.

3. Apply conductive lubrication
4. Try to ensure that the line voltage is balanced to ground. This can be difficult for IT, TT, TN-CS or Grounded leg systems
5. Use an insulated bearing as recommended by the motor manufacturer

NOTE

Motors from reputable manufacturers will typically have these fitted as standard in motors of this size.

If found to be necessary and after consultation with Danfoss:

6. Lower the IGBT switching frequency
7. Modify the inverter waveform, 60° AVM vs. SFAVM
8. Install a shaft grounding system or use an isolating coupling between motor and load
9. Use minimum speed settings if possible
10. Use a dU/dt or sinus filter

4.6.21 Control Cable Routing

Tie down all control wires to the designated control cable routing as shown in the picture. Remember to connect the shields in a proper way to ensure optimum electrical immunity.

Fieldbus connection

Connections are made to the relevant options on the control card. For details, see the relevant fieldbus instruction. The cable must be placed in the provided path inside the frequency converter and tied down together with other control wires (see *Illustration 4.32* and *Illustration 4.33*).

4

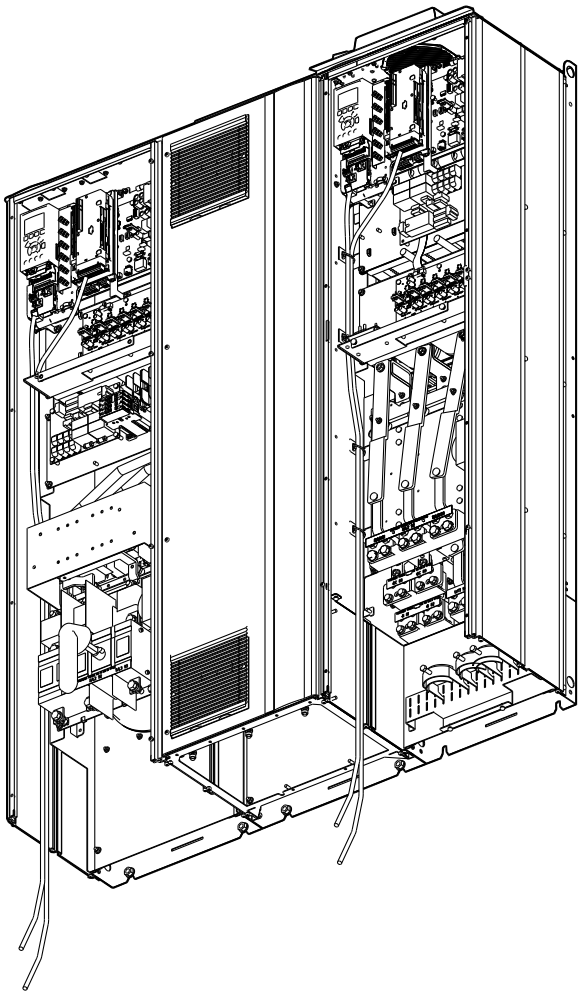

Illustration 4.32 Control Card Wiring Path for the D13

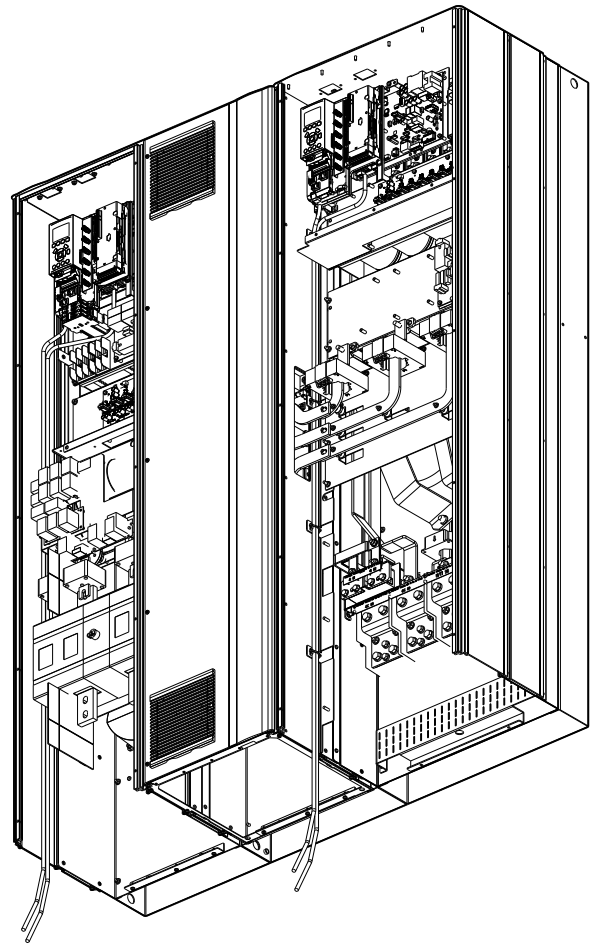

Illustration 4.33 Control Card Wiring Path for the E9

4.6.22 Access to Control Terminals

All terminals to the control cables are located beneath the LCP (both filter and frequency converter LCP). They are accessed by opening the door of the unit.

4.6.23 Electrical Installation, Control Terminals

To connect the cable to the terminal

1. Strip insulation by about 9-10 mm

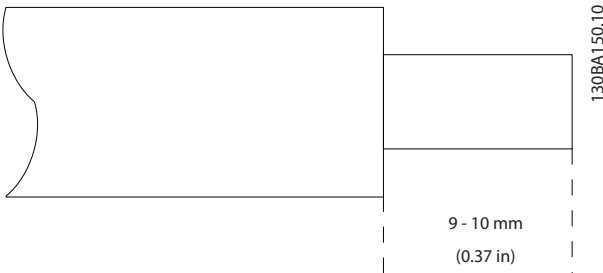

Illustration 4.34

2. Insert a screwdriver¹⁾ in the square hole.
3. Insert the cable in the adjacent circular hole.

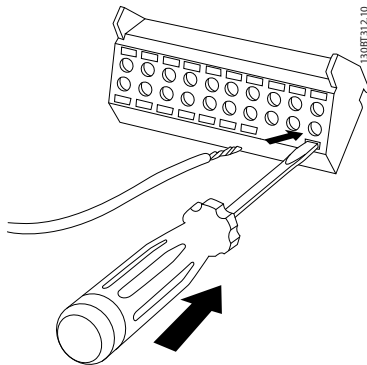

Illustration 4.35

4. Remove the screwdriver. The cable is now mounted in the terminal.

To remove the cable from the terminal

1. Insert a screw driver¹⁾ in the square hole.
2. Pull out the cable.

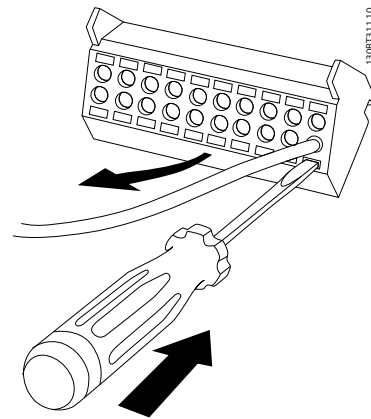

Illustration 4.36

¹⁾ Max. 0.4 x 2.5 mm

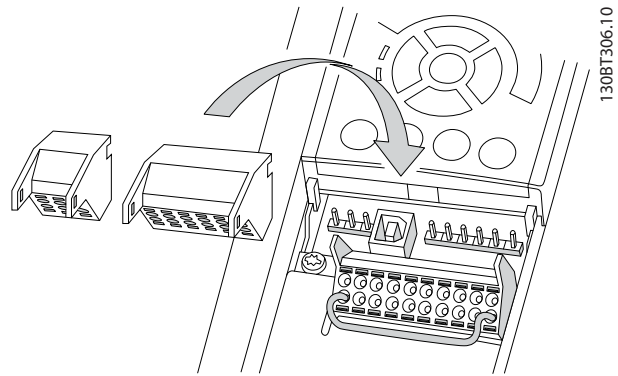

Illustration 4.37

4.7 Connection Examples for Control of Motor with External Signal Provider

NOTE

The following examples refer only to the frequency converter control card (right LCP), *not* the filter.

4.7.1 Start/Stop

Terminal 18 = 5-10 Terminal 18 Digital Input [8] Start
 Terminal 27 = 5-12 Terminal 27 Digital Input [0] No operation (Default coast inverse)
 Terminal 37 = Safe stop

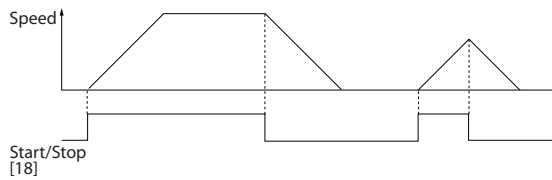
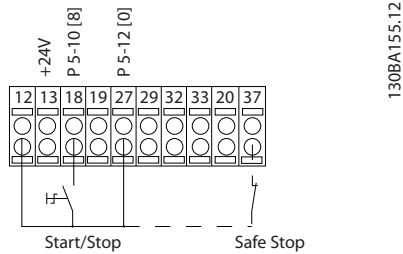

Illustration 4.38

4.7.2 Pulse Start/Stop

Terminal 18 = 5-10 Terminal 18 Digital Input [9] Latched start
 Terminal 27 = 5-12 Terminal 27 Digital Input [6] Stop inverse
 Terminal 37 = Safe stop

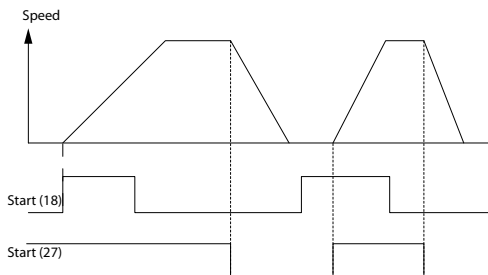
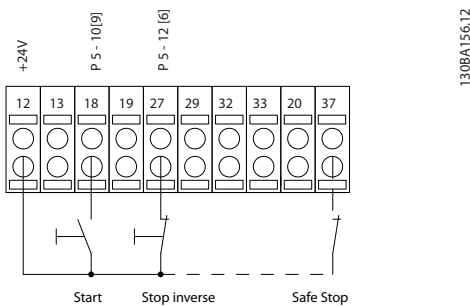

Illustration 4.39

4.7.3 Speed Up/Down

Terminals 29/32 = Speed up/down

Terminal 18 = 5-10 Terminal 18 Digital Input Start [9] (default)
 Terminal 27 = 5-12 Terminal 27 Digital Input Freeze reference [19]
 Terminal 29 = 5-13 Terminal 29 Digital Input Speed up [21]
 Terminal 32 = 5-14 Terminal 32 Digital Input Speed down [22]

NOTE

Terminal 29 only in FC x02 (x=series type).

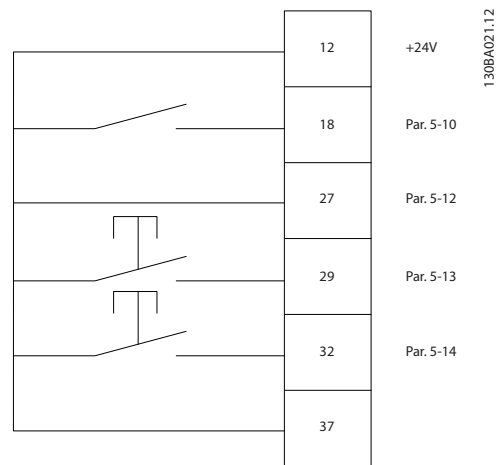

Illustration 4.40

4.7.4 Potentiometer Reference

Voltage reference via a potentiometer

Reference Source 1 = [1] Analog input 53 (default)

Terminal 53, Low Voltage = 0 V

Terminal 53, High Voltage = 10 V

Terminal 53, Low Ref./Feedback = 0 RPM

Terminal 53, High Ref./Feedback = 1500 RPM

Switch S201 = OFF (U)

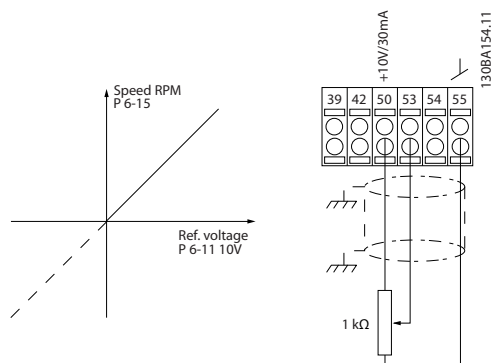

Illustration 4.41

4.8 Electrical Installation - Additional

4.8.1 Electrical Installation, Control Cables

4

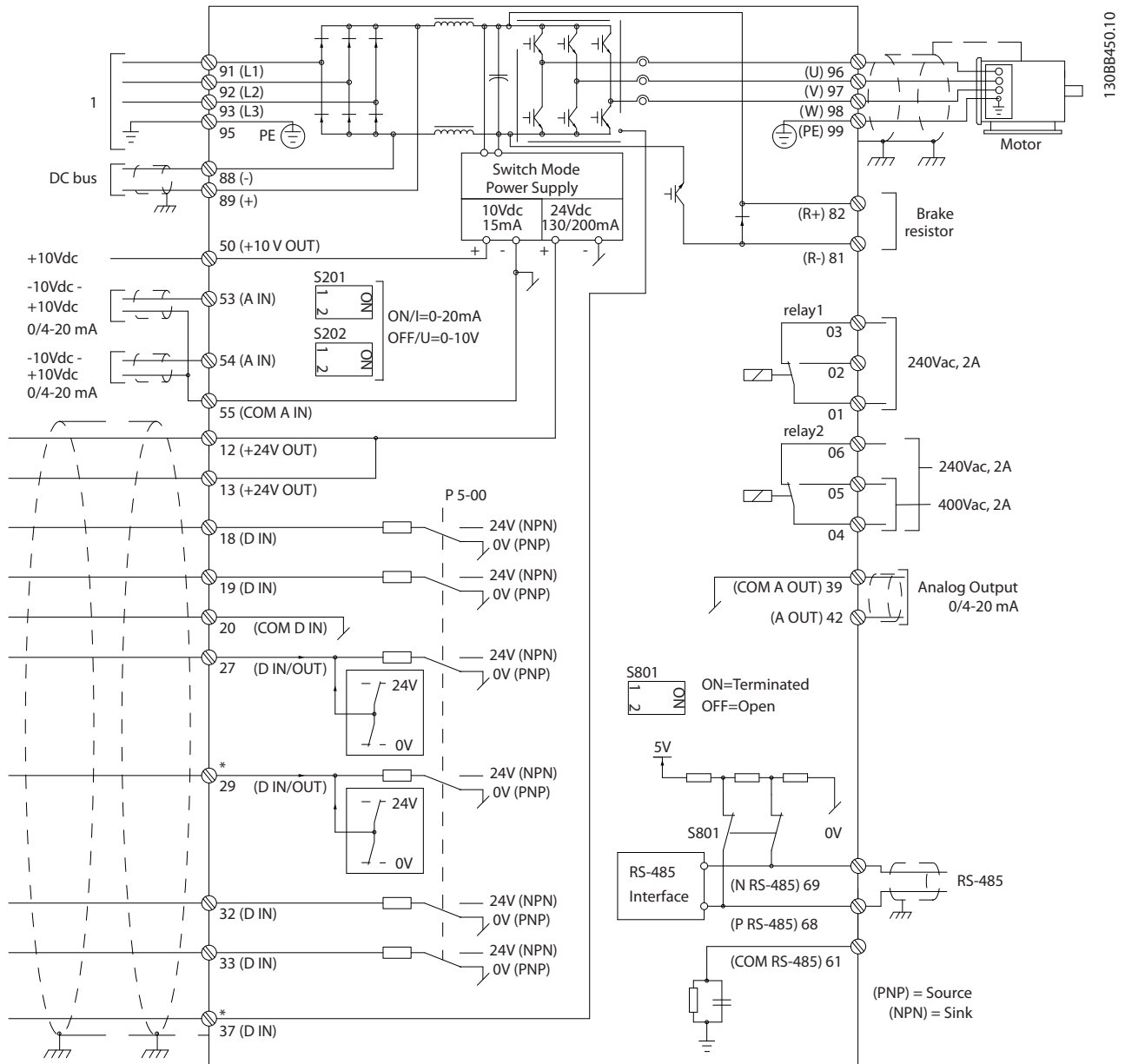

Illustration 4.42 Diagram Showing All Electrical Terminals without Options.

1: Connection to filter

Terminal 37 is the input to be used for Safe Stop. For instructions on Safe Stop installation, refer to the section *Safe Stop Installation* in the frequency converter Design Guide. See also sections *Safe Stop* and *Safe Stop Installation*.

Very long control cables and analogue signals may in rare cases and depending on installation result in 50/60 Hz earth loops due to noise from mains supply cables.

If this occurs, it may be necessary to break the screen or insert a 100 nF capacitor between screen and chassis.

The digital and analog inputs and outputs must be connected separately to the control cards of the unit (both filter and drive, terminal 20, 55, 39) to avoid earth currents from both groups to affect other groups. For example, switching on the digital input may disturb the analog input signal.

Input polarity of control terminals

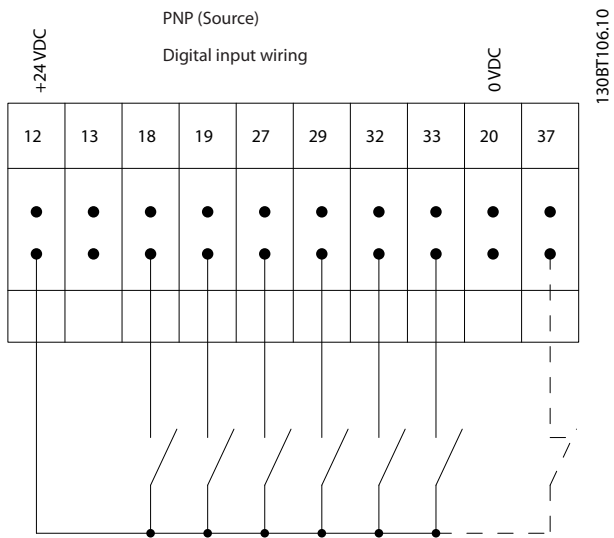

Illustration 4.43

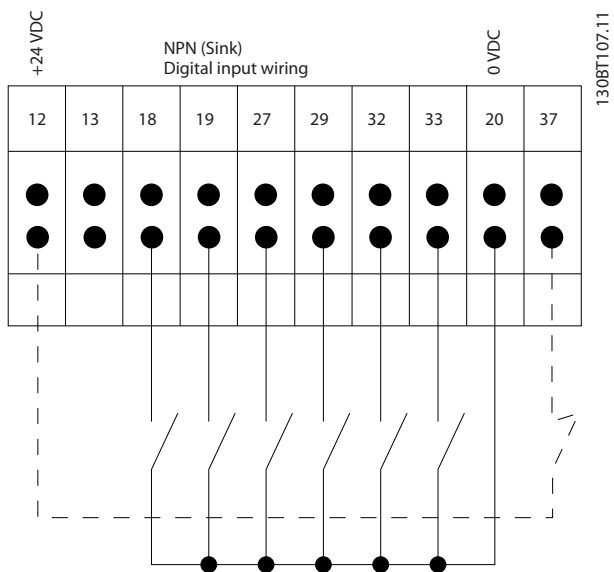

Illustration 4.44

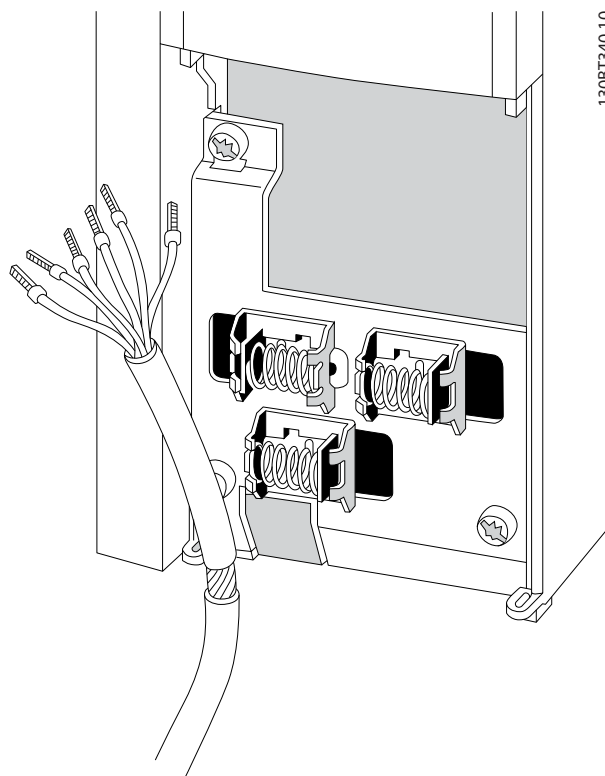

Illustration 4.45

Connect the wires as described in the Operating Instructions for the frequency converter. Remember to connect the shields in a proper way to ensure optimum electrical immunity.

NOTE

To comply with EMC emission specifications, screened/ armoured cables are recommended. If an unscreened/ unarmoured cable is used, *4.6.13 Power and Control Wiring for Unscreened Cables*. If unscreened control cables are used, it is recommended to use ferrite cores to improve EMC performance.

4.8.2 Switches S201, S202, and S801

Switches S201 (A53) and S202 (A54) are used to select a current (0-20 mA) or a voltage (-10 to +10 V) configuration of the analog input terminals 53 and 54 respectively.

Switch S801 (BUS TER.) can be used to enable termination on the RS-485 port (terminals 68 and 69).

See *Illustration 4.42*.

Default setting:

S201 (A53) = OFF (voltage input)

S202 (A54) = OFF (voltage input)

S801 (Bus termination) = OFF

NOTE

When changing the function of S201, S202 or S801 be careful not to use force for the switch over. It is recommended to remove the LCP fixture (cradle) when operating the switches. The switches must not be operated with power on the frequency converter.

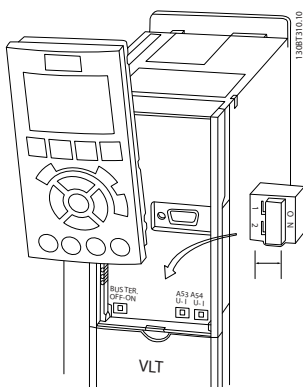

Illustration 4.46

4.9 Final Set-up and Test

To test the set-up and ensure that the frequency converter is running, follow these steps.

Step 1. Locate the motor name plate

NOTE

The motor is either star- (Y) or delta- connected (Δ). This information is located on the motor name plate data.

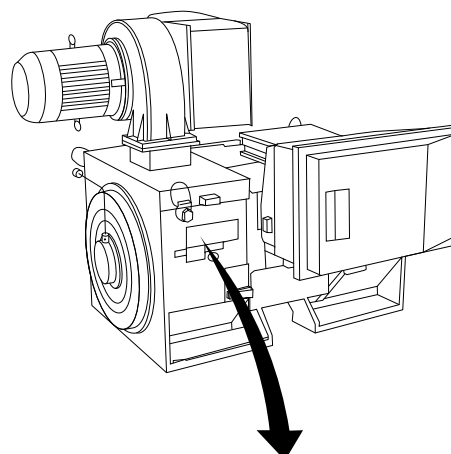

130BA767.10

THREE PHASE INDUCTION MOTOR				
MOD MCV 315E	Nr.	135189 12 04	IL/IN 6.5	
kW 400	PRIMARY			SF 1.15
HP 536	V 690	A 410.6	CONN Y	COS f 0.85 40
mm 1481	V	A	CONN	AMB 40 °C
Hz 50	V	A	CONN	ALT 1000 m
DESIGNN	SECONDARY			RISE 80 °C
DUTY S1	V	A	CONN	ENCLOSURE IP23
INSUL I	EFFICIENCY %	95.8%	100%	95.8% 75% WEIGHT 1.83 ton

⚠ CAUTION

Illustration 4.47

Step 2. Enter the motor name plate data in this parameter list.

To access this list first press [Quick Menu] then select "Q2 Quick Setup".

1.	1-20 Motor Power [kW] 1-21 Motor Power [HP]
2.	1-22 Motor Voltage
3.	1-23 Motor Frequency
4.	1-24 Motor Current
5.	1-25 Motor Nominal Speed

Table 4.46

Step 3. Activate the Automatic Motor Adaptation (AMA)

Performing an AMA will ensure optimum performance. The AMA measures the values from the motor model equivalent diagram.

1. Connect terminal 37 to terminal 12 (if terminal 37 is available).
2. Connect terminal 27 to terminal 12 or set 5-12 Terminal 27 Digital Input to 'No function' (5-12 Terminal 27 Digital Input [0])
3. Activate the AMA 1-29 Automatic Motor Adaptation (AMA).
4. Choose between complete or reduced AMA. If a Sine-wave filter is mounted, run only the reduced

AMA, or remove the Sine-wave filter during the AMA procedure.

5. Press [OK]. The display shows "Press [Hand On] to start".
6. Press [Hand On]. A progress bar indicates if the AMA is in progress.

Stop the AMA during operation

1. Press [Off] - the frequency converter enters into alarm mode and the display shows that the AMA was terminated by the user.

Successful AMA

1. The display shows "Press [OK] to finish AMA".
2. Press [OK] to exit the AMA state.

Unsuccessful AMA

1. The frequency converter enters into alarm mode. A description of the alarm can be found in *9 Troubleshooting*.
2. "Report Value" in the [Alarm Log] shows the last measuring sequence carried out by the AMA, before the frequency converter entered alarm mode. This number along with the description of the alarm assists in troubleshooting. If contacting Danfoss for service, make sure to mention number and alarm description.

NOTE

Unsuccessful AMA is often caused by incorrectly registered motor name plate data or a too big difference between the motor power size and the frequency converter power size.

Step 4. Set speed limit and ramp time

3-02 Minimum Reference

3-03 Maximum Reference

Set up the desired limits for speed and ramp time

4-11 Motor Speed Low Limit [RPM] or 4-12 Motor Speed Low Limit [Hz]

4-13 Motor Speed High Limit [RPM] or 4-14 Motor Speed High Limit [Hz]

3-41 Ramp 1 Ramp up Time

3-42 Ramp 1 Ramp Down Time

4.10 Additional Connections

4.10.1 Mechanical Brake Control

In hoisting/lowering applications, it is necessary to be able to control an electro-mechanical brake:

- Control the brake using any relay output or digital output (terminal 27 or 29).
- Keep the output closed (voltage-free) as long as the frequency converter is unable to 'support' the

motor, for example due to the load being too heavy.

- Select *[32] Mechanical brake control* in parameter group 5-4* for applications with an electro-mechanical brake.
- The brake is released when the motor current exceeds the preset value in *2-20 Release Brake Current*.
- The brake is engaged when the output frequency is less than the frequency set in *2-21 Activate Brake Speed [RPM]* or *2-22 Activate Brake Speed [Hz]*, and only if the frequency converter carries out a stop command.

If the frequency converter is in alarm mode or in an over-voltage situation, the mechanical brake immediately cuts in.

4

4.10.2 Parallel Connection of Motors

The frequency converter can control several parallel-connected motors. The total current consumption of the motors must not exceed the rated output current $I_{M,N}$ for the frequency converter.

NOTE

Installations with cables connected in a common joint as in *Illustration 4.48*, is only recommended for short cable lengths.

NOTE

When motors are connected in parallel, *1-29 Automatic Motor Adaptation (AMA)* cannot be used.

NOTE

The electronic thermal relay (ETR) of the frequency converter cannot be used as motor protection for the individual motor in systems with parallel-connected motors. Provide further motor protection by e.g. thermistors in each motor or individual thermal relays (circuit breakers are not suitable as protection).

Problems may arise at start and at low RPM values if motor sizes are widely different because small motors' relatively high ohmic resistance in the stator calls for a higher voltage at start and at low RPM values.

4.10.3 Motor Thermal Protection

The electronic thermal relay in the frequency converter has received UL-approval for single motor protection, when *1-90 Motor Thermal Protection* is set for *ETR Trip* and *1-24 Motor Current* is set to the rated motor current (see motor name plate).

For thermal motor protection it is also possible to use the MCB 112 PTC Thermistor Card option. This card provides ATEX certificate to protect motors in explosion hazardous areas, Zone 1/21 and Zone 2/22. When *1-90 Motor Thermal Protection* is set to *[20] ATEX ETR* is combined with the use of MCB 112, it is possible to control an Ex-e motor in explosion hazardous areas. Consult the programming guide for details on how to set up the frequency converter for safe operation of Ex-e motors.

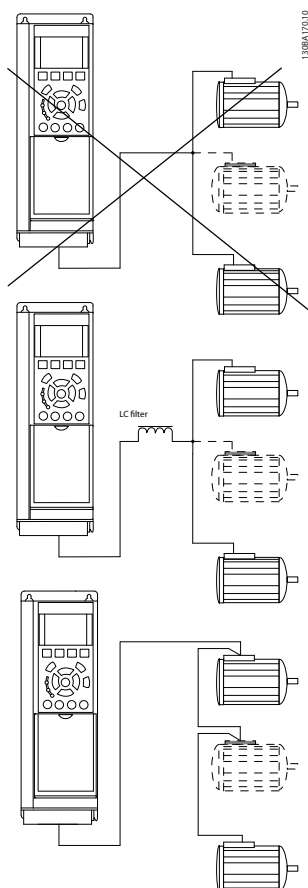

Illustration 4.48

5 How to Operate the Low Harmonic Drive

5.1.1 Ways of Operation

The Low Harmonic Drive can be operated in 2 ways

1. Graphical Local Control Panel (GLCP)
2. RS-485 serial communication or USB, both for PC connection

5.1.2 How to Operate Graphical LCP (GLCP)

The Low Harmonic Drive is equipped with two LCPs, one on the frequency converter section (to the right) of the drive and one on the active filter section (to the left). The filter LCP is operated the same way as the frequency converter LCP. Each LCP controls only the unit it is connected to and there is no communication between the two LCPs.

NOTE

The active filter should be in Auto Mode, i.e. the [Auto On] key must be pressed on the filter LCP

The following instructions are valid for the GLCP (LCP 102).

The GLCP is divided into four functional groups

1. Graphical display with Status lines.
2. Menu keys and indicator lights (LED's) - selecting mode, changing parameters and switching between display functions.
3. Navigation keys and indicator lights (LEDs).
4. Operation keys and indicator lights (LEDs).

Graphical display

The LCD-display is back-lit with a total of 6 alpha-numeric lines. All data is displayed on the LCP which can show up to five operating variables while in [Status] mode.

Illustration 5.1 shows an example of the frequency converter LCP. The filter LCP looks identical but displays information related to the filter operation.

Display lines

- a. **Status line:** Status messages displaying icons and graphics.
- b. **Line 1-2:** Operator data lines displaying data and variables defined or chosen by the user. By pressing the [Status] key, up to one extra line can be added.
- c. **Status line:** Status messages displaying text.

The display is divided into 3 sections:

Top section (a)

shows the status when in status mode or up to 2 variables when not in status mode and in the case of Alarm/Warning.

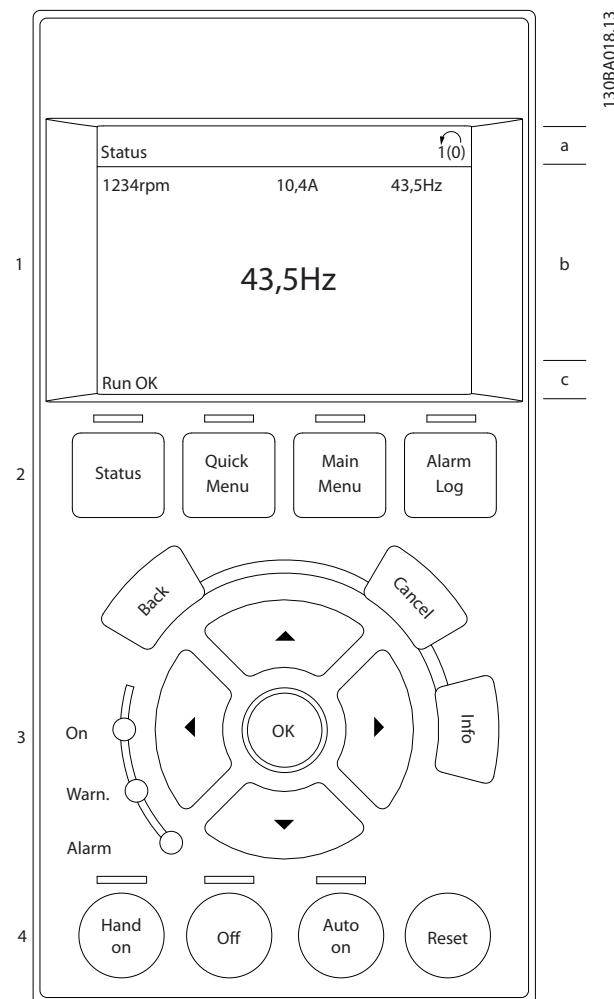

Illustration 5.1 LCP

The number of the Active Set-up (selected as the Active Set-up in par. 0-10) is shown. When programming in another Set-up than the Active Set-up, the number of the Set-up being programmed appears to the right in brackets.

Middle section (b)

shows up to 5 variables with related unit, regardless of status. In case of alarm/warning, the warning is shown instead of the variables.

It is possible to toggle between three status read-out displays by pressing the [Status] key.

Operating variables with different formatting are shown in each status screen - see below.

Several values or measurements can be linked to each of the displayed operating variables. The values/measurements to be displayed can be defined via par. 0-20, 0-21, 0-22, 0-23, and 0-24, which can be accessed via [Quick Menu], "Q3 Function Setups", "Q3-1 General Settings", "Q3-11 Display Settings".

Each value/measurement readout parameter selected in par. 0-20 to par. 0-24 has its own scale and number of digits after a possible decimal point. Larger numeric values are displayed with few digits after the decimal point.
Ex.: Current readout
5.25 A; 15.2 A 105 A.

Status display I

This read-out state is standard after start-up or initialization. Press [Info] to obtain information about the value/measurement linked to the displayed operating variables (1.1, 1.2, 1.3, 2, and 3).

See the operating variables shown in the display in this illustration. 1.1, 1.2 and 1.3 are shown in small size. 2 and 3 are shown in medium size.

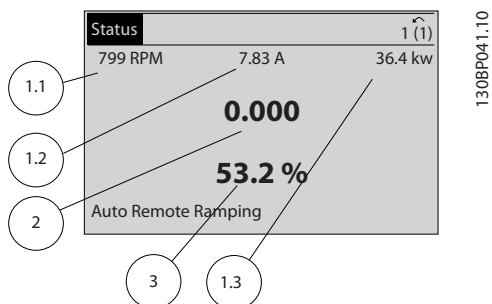

Illustration 5.2

Status display II

See the operating variables (1.1, 1.2, 1.3, and 2) shown in the display in this illustration. In the example, Speed, Motor current, Motor power and Frequency are selected as variables in the first and second lines.
1.1, 1.2 and 1.3 are shown in small size. 2 is shown in large size.

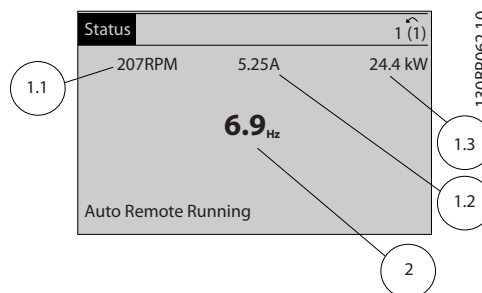

Illustration 5.3

Status display III:

This state displays the event and action of the Smart Logic Control. For further information, see section *Smart Logic Control*.

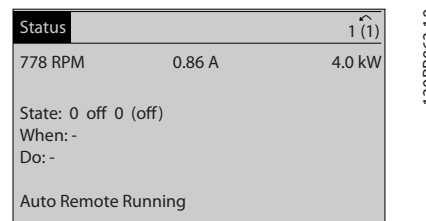

Illustration 5.4

NOTE

Status display III is not available on the filter LCP

Bottom section

always shows the state of the frequency converter in Status mode.

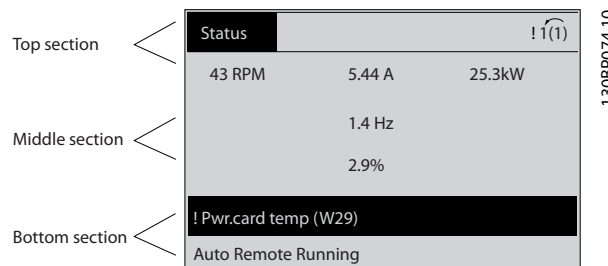

Illustration 5.5

Display contrast adjustment

Press [Status] and [▲] for darker display
Press [Status] and [▼] for brighter display

Indicator lights (LEDs)

If certain threshold values are exceeded, the alarm and/or warning LED lights up. A status and alarm text appear on the control panel. The On LED is activated when the frequency converter receives power from mains voltage, a DC bus terminal, or an external 24 V supply. At the same time, the back light is on.

- Green LED/On: Control section is working.
- Yellow LED/Warn.: Indicates a warning.
- Flashing Red LED/Alarm: Indicates an alarm.

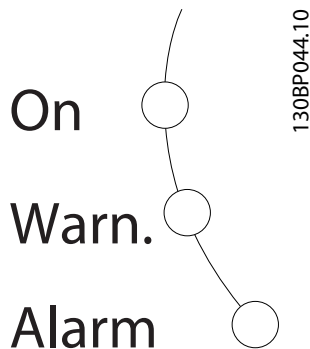

Illustration 5.6

GLCP keys

Menu keys

The menu keys are divided into functions. The keys below the display and indicator lamps are used for parameter set-up, including choice of display indication during normal operation.



Illustration 5.7

[Status]

Indicates the status of the frequency converter (and/or the motor) or the filter respectively. On the drive LCP, 3 different readouts can be chosen by pressing the [Status] key:

5 line readouts, 4 line readouts or Smart Logic Control. Smart Logic Control is not available for the filter.

Use [Status] for selecting the mode of display or for changing back to Display mode from either the Quick Menu mode, the Main Menu mode or Alarm mode. Also press the [Status] key to toggle single or double read-out mode.

[Quick Menu]

Allows quick set-up of the frequency converter or the filter.

The most common functions can be programmed here.

The [Quick Menu] consists of:

- Q1: My Personal Menu
- Q2: Quick Setup
- Q3: Function Setups (drive LCP only)
- Q5: Changes Made
- Q6: Loggings

The Function set-up provides quick and easy access to all parameters required for the majority of applications.

Amongst other features it also includes parameters for selecting which variables to display on the LCP.

Since the active filter is an integrated part of the Low Harmonic Drive only a minimum of programming is necessary. The filter LCP is mainly used to display information about filter operation such as THD of voltage or current, corrected current, injected current or Cos ϕ and True Power Factor.

The Quick Menu parameters can be accessed immediately unless a password has been created via parameters 0-60, 0-61, 0-65 or 0-66.

It is possible to switch directly between Quick Menu mode and Main Menu mode.

[Main Menu]

is used for programming all parameters.

The Main Menu parameters can be accessed immediately unless a password has been created via par. 0-60, 0-61, 0-65 or 0-66. For the majority of applications it is not necessary to access the Main Menu parameters but instead the Quick Menu, Quick Setup and Function Setups provides the simplest and quickest access to the typical required parameters.

It is possible to switch directly between Main Menu mode and Quick Menu mode.

Parameter shortcut can be carried out by pressing down the [Main Menu] key for 3 s. The parameter shortcut allows direct access to any parameter.

[Alarm Log]

displays an Alarm list of the five latest alarms (numbered A1-A5). To obtain additional details about an alarm, use the navigation keys to manoeuvre to the alarm number and press [OK]. Information is displayed about the condition of the frequency converter or filter before it enters the alarm mode.

[Back]

reverts to the previous step or layer in the navigation structure.

[Cancel]

last change or command will be cancelled as long as the display has not been changed.

[Info]

displays information about a command, parameter, or function in any display window. [Info] provides detailed information when needed.

Exit Info mode by pressing either [Info], [Back], or [Cancel].



Illustration 5.8



Illustration 5.9



Illustration 5.10

Navigation keys

The four navigation keys are used to navigate between the different choices available in [Quick Menu], [Main Menu] and [Alarm Log]. Use the keys to move the cursor.

[OK]

is used for choosing a parameter marked by the cursor and for enabling the change of a parameter.

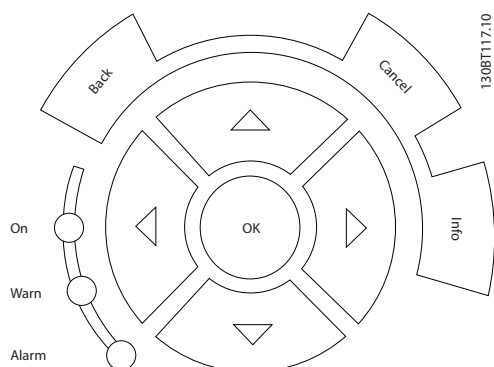

Illustration 5.11

Operation keys

for local control are found at the bottom of the control panel.

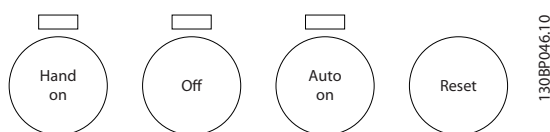

Illustration 5.12

[Hand On]

enables control of the frequency converter via the GLCP. [Hand On] also starts the motor, and it is now possible to give the motor speed reference by means of the arrow keys. The key can be [1] Enabled or [0] Disabled via 0-40 [Hand on] Key on LCP.

The following control signals will still be active when [Hand On] is activated:

- [Hand On] - [Off] - [Auto On]
- Reset
- Coasting stop inverse (motor coasting to stop)
- Reversing

- Set-up select lsb - Set-up select msb
- Stop command from serial communication
- Quick stop
- DC brake

NOTE

External stop signals activated by means of control signals or a serial bus will override a "start" command via the LCP.

[Off]

stops the connected motor (when pressed on the drive LCP) or the filter (when pressed on the filter LCP). The key can be [1] Enabled or [0] Disabled via 0-41 [Off] Key on LCP. If no external stop function is selected and the [Off] key is inactive the motor can only be stopped by disconnecting the mains supply.

[Auto On]

enables the frequency converter to be controlled via the control terminals and/or serial communication. When a start signal is applied on the control terminals and/or the bus, the frequency converter will start. The key can be [1] Enabled or [0] Disabled via 0-42 [Auto on] Key on LCP.

NOTE

[Auto On] must be pressed on the filter LCP.

NOTE

An active HAND-OFF-AUTO signal via the digital inputs has higher priority than the control keys [Hand On] – [Auto On].

[Reset]

is used for resetting the frequency converter or filter after an alarm (trip). The key can be [1] Enabled or [0] Disabled via par. 0-43 Reset Keys on LCP.

The parameter shortcut

can be carried out by holding down the [Main Menu] key for 3 seconds. The parameter shortcut allows direct access to any parameter.

5.1.3 Changing Data

1. Press [Quick Menu] or [Main Menu] key.
2. Press [▲] and [▼] to find parameter group to edit.
3. Press [OK] key.
4. Press [▲] and [▼] to find parameter to edit.
5. Press [OK] key.
6. Press [▲] and [▼] to select correct parameter setting. Or, to move to digits within a number, press keys. Cursor indicates digit selected to change. [▲] increases the value, [▼] decreases the value.

- Press [Cancel] to disregard change, or press [OK] to accept change and enter new setting.

5.1.4 Changing a Text Value

If the selected parameter is a text value, change the text value with the [▲]/[▼] keys.

[▲] increases the value, and [▼] decreases the value. Place the cursor on the value to be saved and press [OK].

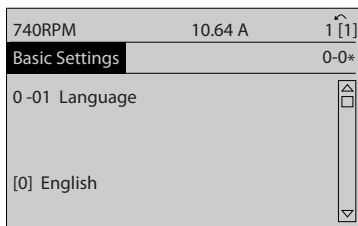

130BP068.10

Illustration 5.13 Display Example

5.1.5 Changing a Group of Numeric Data Values

If the chosen parameter represents a numeric data value, change the chosen data value with the [◀] and [▶] keys as well as the up/down [▲] [▼] keys. Use the [◀] and [▶] keys to move the cursor horizontally.

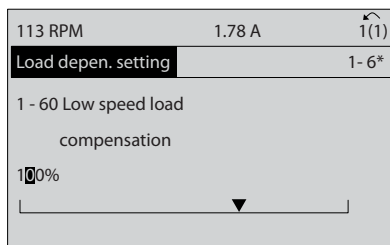

130BP069.10

Illustration 5.14 Display Example

Use [▲] and [▼] to change the data value. [▲] enlarges the data value, and [▼] reduces the data value. Place the cursor on the value to be saved and press [OK].

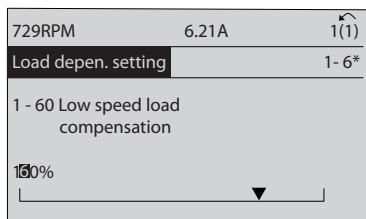

130BP070.10

Illustration 5.15 Display Example

5.1.6 Changing of Data Value, Step-by-Step

Certain parameters can be changed step by step or infinitely variably. This applies to 1-20 Motor Power [kW], 1-22 Motor Voltage and 1-23 Motor Frequency. The parameters are changed both as a group of numeric data values and as numeric data values infinitely variably.

5.1.7 Read-out and Programming of Indexed Parameters

Parameters are indexed when placed in a rolling stack. 15-30 Alarm Log: Error Code to 15-32 Alarm Log: Time contain a fault log which can be read out. Choose a parameter, press [OK], and use [▲] and [▼] to scroll through the value log.

Use 3-10 Preset Reference as another example: Choose the parameter, press [OK], and use [▲] and [▼] to scroll through the indexed values. To change the parameter value, select the indexed value and press [OK]. Change the value by [▲] and [▼]. Press [OK] to accept the new setting. Press [Cancel] to abort. Press [Back] to leave the parameter.

5.1.8 Quick Transfer of Parameter Settings when Using GLCP

Once the set-up of a frequency converter is complete, it is recommended to store (backup) the parameter settings in the GLCP or on a PC via MCT 10 Set-up Software Tool.

WARNING

Stop the motor before performing any of these operations.

Data storage in LCP

- Go to 0-50 LCP Copy
- Press [OK]
- Select "All to LCP"
- Press [OK]

All parameter settings are now stored in the GLCP indicated by the progress bar. When 100% is reached, press [OK].

The GLCP can now be connected to another frequency converter and the parameter settings copied to this frequency converter.

Data transfer from LCP to Frequency converter

- Go to 0-50 LCP Copy
- Press [OK]

3. Select "All from LCP"
4. Press [OK]

The parameter settings stored in the GLCP are now transferred to the frequency converter indicated by the progress bar. When 100% is reached, press [OK].

5.1.9 Initialisation to Default Settings

There are two ways to initialise the frequency converter to default: Recommended initialisation and manual initialisation.

Please be aware that they have different impact according to the below description.

Recommended initialisation (via 14-22 Operation Mode)

1. Select 14-22 Operation Mode
2. Press [OK]
3. Select "Initialisation" (for NLCP select "2")
4. Press [OK]
5. Remove power to unit and wait for display to turn off.
6. Reconnect power and the frequency converter is reset. Note that first start-up takes a few more seconds
7. Press [Reset]

14-22 Operation Mode initialises all except:

14-50 RFI Filter
 8-30 Protocol
 8-31 Address
 8-32 Baud Rate
 8-35 Minimum Response Delay
 8-36 Max Response Delay
 8-37 Maximum Inter-Char Delay
 15-00 Operating Hours to 15-05 Over Volt's
 15-20 Historic Log: Event to 15-22 Historic Log: Time
 15-30 Alarm Log: Error Code to 15-32 Alarm Log: Time

NOTE

Parameters selected in 0-25 My Personal Menu, will stay present, with default factory setting.

Manual initialisation

NOTE

When carrying out manual initialisation, serial communication, RFI filter settings and fault log settings are reset. Removes parameters selected in 0-25 My Personal Menu.

1. Disconnect from mains and wait until the display turns off.

2a. Press [Status] - [Main Menu] - [OK] at the same time while power up for Graphical LCP (GLCP)

2b. Press [Menu] while power up for LCP 101, Numerical Display

3. Release the keys after 5 s

4. The frequency converter is now programmed according to default settings

This parameter initialises all except:

15-00 Operating Hours
 15-03 Power Up's
 15-04 Over Temp's
 15-05 Over Volt's

5.1.10 RS-485 Bus Connection

Both filter portion and frequency converter can be connected to a controller (or master) together with other loads using the RS-485 standard interface. Terminal 68 is connected to the P signal (TX+, RX+), while terminal 69 is connected to the N signal (TX-,RX-).

Always use parallel connections for the Low Harmonic Drive to ensure that both filter and drive part is connected.

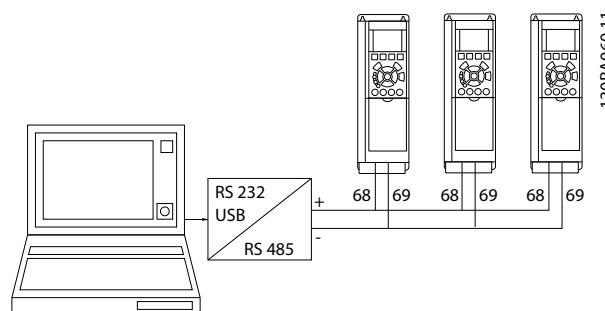

Illustration 5.16 Connection Example

In order to avoid potential equalizing currents in the screen, earth the cable screen via terminal 61, which is connected to the frame via an RC-link.

Bus termination

The RS-485 bus must be terminated by a resistor network at both ends. If the frequency converter is the first or the last device in the RS-485 loop, set the switch S801 on the control card for ON.

For more information, see 4.8.2 Switches S201, S202, and S801.

5.1.11 How to Connect a PC to the Frequency Converter

To control or program the frequency converter (and the filter part) from a PC, install the PC-based Configuration Tool MCT 10.

The PC is connected via a standard (host/device) USB cable to both devices, or via the RS-485 interface as shown in the VLT HVAC Drive *Design Guide, chapter How to Install > Installation of misc. connections.*

NOTE

The USB connection is galvanically isolated from the supply voltage (PELV) and other high-voltage terminals. The USB connection is connected to protection earth on the frequency converter. Use only an isolated laptop as PC connection to the USB connector on the frequency converter.

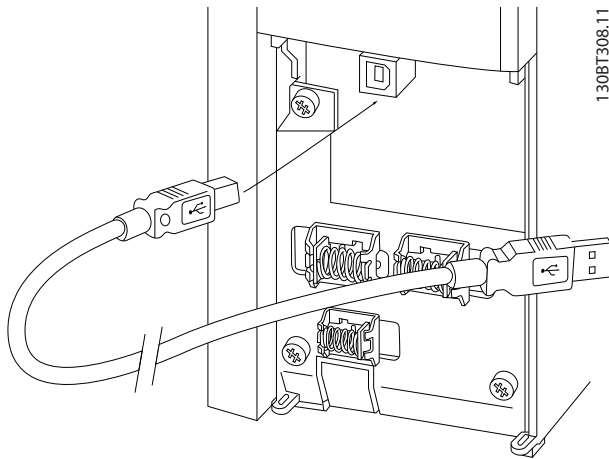

Illustration 5.17 For Control Cable Connections, see 4.6.23 *Electrical Installation, Control Terminals*

5.1.12 PC Software Tools

PC-based Configuration Tool MCT 10

The Low Harmonic Drive is equipped with two serial communication ports. Danfoss provides a PC tool for communication between PC and frequency converter, PC-based Configuration Tool MCT 10. Check for detailed information on this tool.

MCT 10 set-up software

MCT 10 has been designed as an easy to use interactive tool for setting parameters in our frequency converters. The software can be downloaded from the Danfoss internet site <http://www.Danfoss.com/BusinessAreas/Drives-Solutions/SoftwareDownload/DDPC+Software+Program.htm>. The MCT 10 set-up software is useful for:

- Planning a communication network off-line. MCT 10 contains a complete frequency converter database
- Commissioning frequency converters on line
- Saving settings for all frequency converters
- Replacing a frequency converter in a network
- Simple and accurate documentation of frequency converter settings after commissioning.
- Expanding an existing network
- Future developed frequency converters will be supported

MCT 10 set-up software supports Profibus DP-V1 via a Master class 2 connection. It makes it possible to on line read/write parameters in a frequency converter via the Profibus network. This will eliminate the need for an extra communication network.

Save frequency converter settings

1. Connect a PC to the unit via USB com port.

CAUTION

Use a PC, which is isolated from the mains, in conjunction with the USB port. Failure to do so may damage equipment.

2. Open MCT 10 Set-up Software
3. Choose "Read from drive"
4. Choose "Save as"

All parameters are now stored in the PC.

Load frequency converter settings

1. Connect a PC to the frequency converter via USB com port
2. Open MCT 10 Set-up software
3. Choose "Open"– stored files will be shown
4. Open the appropriate file
5. Choose "Write to drive"

All parameter settings are now transferred to the frequency converter.

A separate manual for MCT 10 Set-up Software is available: *MG10RXYY*.

The MCT 10 Set-up software modules

The following modules are included in the software package:

	<p>MCT Set-up 10 Software</p> <ul style="list-style-type: none"> Setting parameters Copy to and from frequency converters Documentation and print out of parameter settings incl. diagrams
	<p>Ext. user interface</p> <ul style="list-style-type: none"> Preventive Maintenance Schedule Clock settings Timed Action Programming Smart Logic Controller Set-up

5

Table 5.1

Ordering number

Order the CD containing MCT 10 Set-up Software using code number 130B1000.

MCT 10 can also be downloaded from the Danfoss Internet: www.danfoss.com, Business Area: Motion Controls.

6 How to Programme the Low Harmonic Drive

6.1 How to Programme the Frequency Converter

6.1.1 Parameter Set-Up

Group	Title	Function
0**	Operation and Display	Parameters used to program the fundamental functions of the frequency converter and the LCP including: selection of language; selection of which variables are displayed at each position in the display (e.g. static duct pressure or condenser water return temperature can be displayed with the setpoint in small digits in the top row and feedback in large digits in the centre of the display); enabling/disabling of the LCP keys; passwords for the LCP; upload and download of commissioned parameters to/from the LCP and setting the built in clock.
1**	Load / Motor	Parameters used to configure the frequency converter for the specific application and motor including: open or closed loop operation; type of application such as compressor, fan or centrifugal pump; motor nameplate data; auto-tuning of the drive to the motor for optimum performance; flying start (typically used for fan applications) and motor thermal protection.
2**	Brakes	Parameters used to configure braking functions of the frequency converter which although not common in many HVAC applications, can be useful on special fan applications. Parameters including: DC braking; dynamic/resistor braking and over voltage control (which provides automatic adjustment of the deceleration rate (auto-ramping) to avoid tripping when decelerating large inertia fans)
3**	Reference / Ramps	Parameters used to program the minimum and maximum reference limits of speed (RPM/Hz) in open loop or in actual units when operating in closed loop); digital/preset references; jog speed; definition of the source of each reference (e.g. which analog input the reference signal is connected to); ramp up and down times and digital potentiometer settings.
4**	Limits / Warnings	Parameters used to program limits and warnings of operation including: allowable motor direction; minimum and maximum motor speeds (e.g. in pump applications it is typical to program a minimum speed to approx 30-40% to ensure pump seals are adequately lubricated at all times, avoid cavitation and ensure adequate head is produced at all times to create flow); torque and current limits to protect the pump, fan or compressor driven by the motor; warnings for low/high current, speed, reference, and feedback; missing motor phase protection; speed bypass frequencies including semi-automatic setup of these frequencies (e.g. to avoid resonance conditions on cooling tower and other fans).
5**	Digital In / Out	Parameters used to program the functions of all digital inputs, digital outputs, relay outputs, pulse inputs and pulse outputs for terminals on the control card and all option cards.
6**	Analog In / Out	Parameters used to program the functions associated with all analog inputs and analog outputs for the terminals on the control card and General Purpose I/O option (MCB 101) (note: NOT Analog I/O option MCB 109, see parameter group 26-00) including: analog input live zero timeout function (which for example can be used to command a cooling tower fan to operate at full speed if the condenser water return sensor fails); scaling of the analog input signals (for example to match the analog input to the mA and pressure range of a static duct pressure sensor); filter time constant to filter out electrical noise on the analog signal which can sometimes occur when long cables are installed; function and scaling of the analog outputs (for example to provide an analog output representing motor current or kW to an analog input of a DDC controller) and to configure the analog outputs to be controlled by the BMS via a high level interface (HLI) (e.g. to control a chilled water valve) including ability to define a default value of these outputs in the event of the HLI failing.
8**	Communication and Options	Parameters used for configuring and monitoring functions associated with the serial communications / high level interface to the frequency converter
9**	Profibus	Parameters only applicable when a Profibus option is installed.
10**	CAN Fieldbus	Parameters only applicable when a DeviceNet option is installed.

Group	Title	Function
11**	LonWorks	Parameters only applicable when a Lonworks option is installed.
13**	Smart Logic Controller	Parameters used to configure the built in Smart Logic Controller (SLC) which can be used for simple functions such as comparators (e.g. if running above xHz, activate output relay), timers (e.g. when a start signal is applied, first activate output relay to open supply air damper and wait x seconds before ramping up) or a more complex sequence of user defined actions executed by the SLC when the associated user defined event is evaluated as TRUE by the SLC. (For example, initiate an economiser mode in a simple AHU cooling application control scheme where there is no BMS. For such an application the SLC can monitor the outside air relative humidity and if it is below a defined value, the supply air temperature setpoint could be automatically increased. With the frequency converter monitoring the outside air relative humidity and supply air temperature via it's analog inputs and controlling the chilled water valve via one of the extended PI(D) loops and an analog output, it would then modulate that valve to maintain a higher supply air temperature). The SLC can often replace the need for other external control equipment.
14**	Special Functions	Parameters used to configure special functions of the frequency converter including: setting of the switching frequency to reduce audible noise from the motor (sometimes required for fan applications); kinetic back-up function (especially useful for critical applications in semi-conductor installations where performance under mains dip/mains loss is important); mains imbalance protection; automatic reset (to avoid the need for a manual reset of Alarms); energy optimisation parameters (which typically do not need changing but enable fine tuning of this automatic function (if necessary) ensuring the frequency converter and motor combination operate at their optimum efficiency at full and partial load conditions) and auto-derating functions (which enable the frequency converter to continue operation at reduced performance under extreme operating conditions ensuring maximum up time).
15**	FC Information	Parameters providing operating data and other drive information including: operating and running hour counters; kWh counter; resetting of the running and kWh counters; alarm/fault log (where the past 10 alarms are logged along with any associated value and time) and drive and option card identification parameters such as code number and software version.
16**	Data Readouts	Read only parameters which display the status/value of many operating variables which can be displayed on the LCP or viewed in this parameter group. These parameters can be particularly useful during commissioning when interfacing with a BMS via a high level interface.
18**	Info & Readouts	Read only parameters which display the last 10 preventative maintenance log items, actions and time and the value of analog inputs and outputs on the Analog I/O option card which can be particularly useful during commissioning when interfacing with a BMS via a high level interface.
20**	FC Closed Loop	Parameters used to configure the closed loop PI(D) controller which controls the speed of the pump, fan or compressor in closed loop mode including: defining where each of the 3 possible feedback signals come from (e.g. which analog input or the BMS HLI); conversion factor for each of the feedback signals (e.g. where a pressure signal is used for indication of flow in an AHU or converting from pressure to temperature in a compressor application); engineering unit for the reference and feedback (e.g. Pa, kPa, m Wg, in Wg, bar, m3/s, m3/h, °C, °F etc); the function (e.g. sum, difference, average, minimum or maximum) used to calculate the resulting feedback for single zone applications or the control philosophy for multi-zone applications; programming of the setpoint(s) and manual or auto-tuning of the PI(D) loop.
21**	Extended Closed Loop	Parameters used to configure the 3 extended closed loop PI(D) controllers which for example can be used to control external actuators (e.g. chilled water valve to maintain supply air temperature in a VAV system) including: engineering unit for the reference and feedback of each controller (e.g. °C, °F etc); defining the range of the reference/setpoint for each controller; defining where each of the references/setpoints and feedback signals come from (e.g. which analog input or the BMS HLI); programming of the setpoint and manual or auto-tuning of the each of the PI(D) controllers.

Group	Title	Function
22**	Application Functions	Parameters used to monitor, protect and control pumps, fans and compressors including: no flow detection and protection of pumps (including auto-setup of this function); dry pump protection; end of curve detection and protection of pumps; sleep mode (especially useful for cooling tower and booster pump sets); broken belt detection (typically used for fan applications to detect no air flow instead of using a Δp switch installed across the fan); short cycle protection of compressors and pump flow compensation of setpoint (especially useful for secondary chilled water pump applications where the Δp sensor has been installed close to the pump and not across the furthest most significant load(s) in the system; using this function can compensate for the sensor installation and help to realise the maximum energy savings).
23**	Time Based Functions	Time based parameters including: those used to initiate daily or weekly actions based on the built in real time clock (e.g. change of setpoint for night set back mode or start/stop of the pump/fan/compressor start/stop of a external equipment); preventative maintenance functions which can be based on running or operating hour time intervals or on specific dates and times; energy log (especially useful in retrofit applications or where information of the actual historical load (kW) on the pump/fan/compressor is of interest); trending (especially useful in retrofit or other applications where there is an interest to log operating power, current, frequency or speed of the pump/fan/compressor for analysis and a payback counter).
24**	Application Functions 2	Parameters used to set-up Fire Mode and/or to control a bypass contactor/starter if designed into the system.
25**	Cascade Controller	Parameters used to configure and monitor the built in pump cascade controller (typically used for pump booster sets).
26**	Analog I/O Option MCB 109	Parameters used to configure the Analog I/O option (MCB 109) including: definition of the analog input types (e.g. voltage, Pt1000 or Ni1000) and scaling and definition of the analog output functions and scaling.

Table 6.1 Parameter Groups

Parameter descriptions and selections are displayed on the graphic (GLCP) or numeric (NLCP) display. (See relevant section for details.) Access the parameters by pressing the [Quick Menu] or [Main Menu] key on the LCP. The Quick Menu is used primarily for commissioning the unit at start-up by providing the parameters necessary to start operation. The Main Menu provides access to all parameters for detailed application programming.

All digital input/output and analog input/output terminals are multifunctional. All terminals have factory default functions suitable for the majority of HVAC applications but if other special functions are required, they must be programmed as explained in parameter group 5-** or 6-**.

6.1.2 Quick Menu Mode

Parameter Data

The graphical display (GLCP) provides access to all parameters listed under the Quick Menus. The numeric display (NLCP) only provides access to the Quick Setup parameters. To set parameters using the [Quick Menu] button - enter or change parameter data or settings in accordance with the following procedure

1. Press [Quick Menu]
2. Press [▲] and [▼] to find the parameter to change
3. Press [OK]
4. Press [▲] and [▼] to select the correct parameter setting
5. Press [OK]
6. To move to a different digit within a parameter setting, use the [◀] and [▶]
7. Highlighted area indicates digit selected for change
8. Press [Cancel] to disregard change, or press [OK] to accept change and enter the new setting

Example of changing parameter data

Assume 22-60 Broken Belt Function is set to [Off]. To monitor the fan-belt condition - non- broken or broken - follow this procedure

1. Press [Quick Menu]
2. Choose Function Setups with [▼]
3. Press [OK]
4. Choose Application Settings with [▼]
5. Press [OK]
6. Press [OK] again for Fan Functions.
7. Choose Broken Belt Function by pressing [OK]
8. With [▼], choose [2] Trip

The frequency converter will now trip if a broken fan-belt is detected.

Select [My Personal Menu] to display personal parameters

For example, an AHU or pump OEM may have pre-programmed personal parameters to be in My Personal Menu during factory commissioning to make on-site commissioning/fine tuning simpler. These parameters are selected in 0-25 My Personal Menu. Up to 20 different parameters can be programmed in this menu.

Select [Changes Made] to get information about

- The last 10 changes. Use [▲] and [▼] to scroll between the last 10 changed parameters.
- The changes made since default setting.

Select [Loggings]

to get information about the display line read-outs. The information is shown as graphs.

Only display parameters selected in 0-20 Display Line 1.1 Small and 0-24 Display Line 3 Large can be viewed. It is possible to store up to 120 samples in the memory for later reference.

Quick Setup

Efficient Parameter Set-up for VLT HVAC Drive Applications

The parameters can easily be set up for the vast majority of the VLT HVAC Drive applications only by using the [Quick Setup] option.

After pressing [Quick Menu], the different choices in the Quick Menu are listed. See also *Illustration 6.1* and tables Q3-1 to Q3-4 in the following *Function Setups* section.

Example of using the Quick Setup option

Assume you want to set the Ramp Down Time to 100 s:

1. Select [Quick Setup]. 0-01 Language in Quick Setup appears
2. Press [▼] repeatedly until 3-42 Ramp 1 Ramp Down Time appears with the default setting of 20 s
3. Press [OK]
4. Press [◀] to highlight the 3rd digit before the comma
5. Change '0' to '1' by pressing [▲]
6. Press [▶] to highlight the digit '2'
7. Change '2' to '0' by pressing [▼]
8. Press [OK]

The new ramp-down time is now set to 100 s. It is recommended to do the set-up in the order listed.

NOTE

A complete description of the function is found in 6 How to Programme the Low Harmonic Drive.

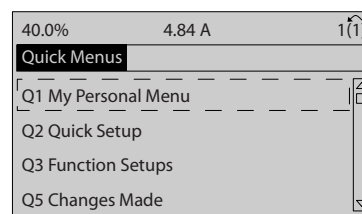

Illustration 6.1 Quick Menu View

The Quick Setup menu gives access to the 18 most important setup parameters of the frequency converter. After programming the frequency converter will, in most cases, be ready for operation. The 18 Quick Setup parameters are shown in *Table 6.2* *Table 6.3*. A complete

description of the function is given in 6 How to Programme the Low Harmonic Drive.

Parameter	[Units]
0-01 Language	
1-20 Motor Power [kW]	[kW]
1-21 Motor Power [HP]	[HP]
1-22 Motor Voltage*	[V]
1-23 Motor Frequency	[Hz]
1-24 Motor Current	[A]
1-25 Motor Nominal Speed	[RPM]
1-28 Motor Rotation Check	[Hz]
3-41 Ramp 1 Ramp Up Time	[s]
3-42 Ramp 1 Ramp Down Time	[s]
4-11 Motor Speed Low Limit [RPM]	[RPM]
4-12 Motor Speed Low Limit [Hz]*	[Hz]
4-13 Motor Speed High Limit [RPM]	[RPM]
4-14 Motor Speed High Limit [Hz]*	[Hz]
3-19 Jog Speed [RPM]	[RPM]
3-11 Jog Speed [Hz]*	[Hz]
5-12 Terminal 27 Digital Input	
5-40 Function Relay**	

Table 6.2 Quick Setup Parameters

*The display showing depends on choices made in 0-02 Motor Speed Unit and 0-03 Regional Settings. The default settings of 0-02 Motor Speed Unit and 0-03 Regional Settings depend on which region of the world the frequency converter is supplied to but can be re-programmed as required.

** 5-40 Function Relay, is an array, where one may choose between Relay1 [0] or Relay2 [1]. Standard setting is Relay1 [0] with the default choice Alarm [9].

See the parameter description in the section Commonly Used Parameters.

For a detailed information about settings and programming, please see the VLT HVAC Drive Programming Guide, MG11CXY

X=version number

YY=language

NOTE

If [No Operation] is selected in 5-12 Terminal 27 Digital Input, no connection to +24 V on terminal 27 is necessary to enable start.

If [Coast Inverse] (factory default value) is selected in 5-12 Terminal 27 Digital Input, a connection to +24 V is necessary to enable start.

0-01 Language	
Option:	Function:
	Defines the language to be used in the display. The frequency converter can be delivered with 4 different language

0-01 Language	
Option:	Function:
	packages. English and German are included in all packages. English cannot be erased or manipulated.
[0] *	English Part of Language packages 1 - 4
[1]	Deutsch Part of Language packages 1 - 4
[2]	Francais Part of Language package 1
[3]	Dansk Part of Language package 1
[4]	Spanish Part of Language package 1
[5]	Italiano Part of Language package 1
	Svenska Part of Language package 1
[7]	Nederlands Part of Language package 1
[10]	Chinese Part of Language package 2
	Suomi Part of Language package 1
[22]	English US Part of Language package 4
	Greek Part of Language package 4
	Bras.port Part of Language package 4
	Slovenian Part of Language package 3
	Korean Part of Language package 2
	Japanese Part of Language package 2
	Turkish Part of Language package 4
	Trad.Chinese Part of Language package 2
	Bulgarian Part of Language package 3
	Srpski Part of Language package 3
	Romanian Part of Language package 3
	Magyar Part of Language package 3
	Czech Part of Language package 3
	Polski Part of Language package 4
	Russian Part of Language package 3
	Thai Part of Language package 2
	Bahasa Indonesia Part of Language package 2
[52]	Hrvatski

NOTE

1-20 Motor Power [kW], 1-21 Motor Power [HP], 1-22 Motor Voltage and 1-23 Motor Frequency will not have effect when 1-10 Motor Construction = [1] PM, non salient SPM.

1-20 Motor Power [kW]		
Range:		Function:
Size related*	[0.09 - 3000.00 kW]	Enter the nominal motor power in kW according to the motor nameplate data. The default value corresponds to the nominal rated output of the unit. This parameter cannot be adjusted while the motor is running. Depending on the choices made in <i>0-03 Regional Settings</i> , either <i>1-20 Motor Power [kW]</i> or <i>1-21 Motor Power [HP]</i> is made invisible.

1-21 Motor Power [HP]		
Range:		Function:
Size related*	[0.09 - 3000.00 hp]	Enter the nominal motor power in HP according to the motor nameplate data. The default value corresponds to the nominal rated output of the unit. This parameter cannot be adjusted while the motor is running. Depending on the choices made in <i>0-03 Regional Settings</i> , either <i>1-20 Motor Power [kW]</i> or <i>1-21 Motor Power [HP]</i> is made invisible.

1-22 Motor Voltage		
Range:		Function:
Size related*	[10. - 1000. V]	Enter the nominal motor voltage according to the motor nameplate data. The default value corresponds to the nominal rated output of the unit.
<p>NOTE This parameter cannot be adjusted while the motor is running.</p>		

1-23 Motor Frequency		
Range:		Function:
Size related*	[20 - 1000 Hz]	Select the motor frequency value from the motor nameplate data. For 87 Hz operation with 230/400 V motors, set the nameplate data for 230 V/50 Hz. Adapt <i>4-13 Motor Speed High Limit [RPM]</i> and <i>3-03 Maximum Reference</i> to the 87 Hz application.

NOTE

This parameter cannot be changed while the motor is running.

1-24 Motor Current		
Range:		Function:
Size related*	[0.10 - 10000.00 A]	Enter the nominal motor current value from the motor nameplate

1-24 Motor Current		
Range:		Function:
		data. This data is used for calculating motor torque, motor thermal protection etc.

NOTE

This parameter cannot be changed while the motor is running.

1-25 Motor Nominal Speed		
Range:		Function:
Size related*	[100 - 60000 RPM]	Enter the nominal motor speed value from the motor nameplate data. This data is used for calculating automatic motor compensations.

NOTE

This parameter cannot be changed while the motor is running.

1-28 Motor Rotation Check		
Option:	Function:	
		Following installation and connection of the motor, this function allows the correct motor rotation direction to be verified. Enabling this function overrides any bus commands or digital inputs, except External Interlock and Safe Stop (if included).
[0] *	Off	Motor Rotation Check is not active.
[1]	Enabled	Motor Rotation Check is enabled.

Once the motor rotation check is enabled the display shows: "Note! Motor may run in wrong direction". Pressing [OK], [Back] or [Cancel] will dismiss the message and display a new message: "Press [Hand On] to start the motor. Press [Cancel] to abort". Pressing [Hand On] starts the motor at 5 Hz in forward direction and the display shows: "Motor is running. Check if motor rotation direction is correct. Press [Off] to stop the motor". Pressing [Off] stops the motor and resets *1-28 Motor Rotation Check*. If motor rotation direction is incorrect, two motor phase cables should be interchanged.

WARNING

Mains power must be removed before disconnecting motor phase cables.

3-41 Ramp 1 Ramp Up Time		
Range:		Function:
Size related*	[1.00 - 3600.00 s]	Enter the ramp-up time, i.e. the acceleration time from 0 RPM to 1-25 Motor Nominal Speed. Choose a ramp-up time such that the output current does not exceed the current limit in 4-18 Current Limit during ramping. See ramp-down time in 3-42 Ramp 1 Ramp Down Time.

$$par.3 - 41 = \frac{tacc \times nnom [par.1 - 25]}{ref [rpm]} [s]$$

3-42 Ramp 1 Ramp Down Time		
Range:		Function:
Size related*	[1.00 - 3600.00 s]	Enter the ramp-down time, i.e. the deceleration time from 1-25 Motor Nominal Speed to 0 RPM. Choose a ramp-down time such that no over-voltage arises in the inverter due to regenerative operation of the motor, and such that the generated current does not exceed the current limit set in 4-18 Current Limit. See ramp-up time in 3-41 Ramp 1 Ramp Up Time.

$$par.3 - 42 = \frac{tdec \times nnom [par.1 - 25]}{ref [rpm]}$$

4-14 Motor Speed High Limit [Hz]		
Range:		Function:
Size related*	[par. 4-12 - par. 4-19 Hz]	Enter the maximum limit for motor speed. The Motor Speed High Limit can be set to correspond to the manufacturer's recommended maximum of the motor shaft. The Motor Speed High Limit must exceed the in 4-12 Motor Speed Low Limit [Hz]. Only 4-13 Motor Speed High Limit [RPM] or 4-14 Motor Speed High Limit [Hz] will be displayed depending on other parameters in the Main Menu and depending on default settings dependant on global location.

NOTE

Max. output frequency cannot exceed 10% of the inverter switching frequency (14-01 Switching Frequency).

4-12 Motor Speed Low Limit [Hz]		
Range:		Function:
Size related*	[0 - par. 4-14 Hz]	Enter the minimum limit for motor speed. The Motor Speed Low Limit can be set to correspond to the minimum output frequency of the motor shaft. The Speed Low Limit must not exceed the setting in 4-14 Motor Speed High Limit [Hz].

4-13 Motor Speed High Limit [RPM]		
Range:		Function:
Size related*	[par. 4-11 - 60000. RPM]	Enter the maximum limit for motor speed. The Motor Speed High Limit can be set to correspond to the manufacturer's maximum rated motor. The Motor Speed High Limit must exceed the setting in 4-11 Motor Speed Low Limit [RPM]. Only 4-11 Motor Speed Low Limit [Hz] will be displayed depending on other parameters in the Main Menu and depending on default settings dependant on global location.

NOTE

Max. output frequency cannot exceed 10% of the inverter switching frequency (14-01 Switching Frequency).

NOTE

Any changes in 4-13 Motor Speed High Limit [RPM] will reset the value in 4-53 Warning Speed High to the same value as set in 4-13 Motor Speed High Limit [RPM].

4-11 Motor Speed Low Limit [RPM]		
Range:		Function:
Size related*	[0 - par. 4-13 RPM]	Enter the minimum limit for motor speed. The Motor Speed Low Limit can be set to correspond to the manufacturer's recommended minimum motor speed. The Motor Speed Low Limit must not exceed the setting in 4-13 Motor Speed High Limit [RPM].

3-11 Jog Speed [Hz]		
Range:		Function:
Size related*	[0.0 - par. 4-14 Hz]	The jog speed is a fixed output speed at which the frequency converter is running when the jog function is activated. See also 3-80 Jog Ramp Time.

6.1.3 Function Set-ups

The Function set-up provides quick and easy access to all parameters required for the majority of VLT HVAC Drive applications including most VAV and CAV supply and return fans, cooling tower fans, Primary, Secondary and Condenser Water Pumps and other pump, fan and compressor applications.

How to access Function Set-up - example

Step 1: Turn on the frequency converter (yellow LED lights)

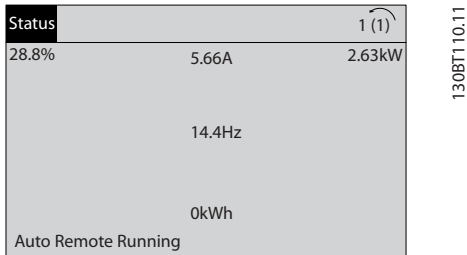

Illustration 6.2

Step 2: Press [Quick Menus] (Quick Menu choices appear).

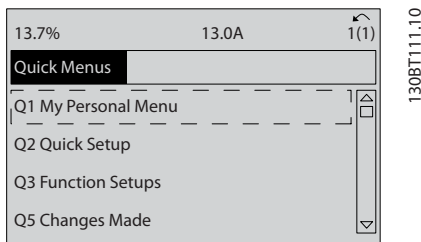

Illustration 6.3

Step 3: Use [▲] and [▼] to scroll down to Function set-ups. Press [OK].

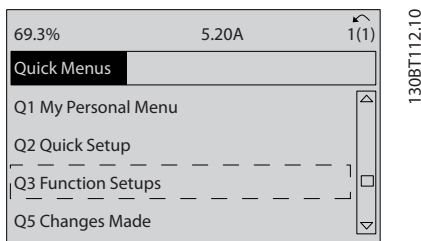

Illustration 6.4

Step 4: Function set-ups choices appear. Choose Q3-1 General Settings. Press [OK].

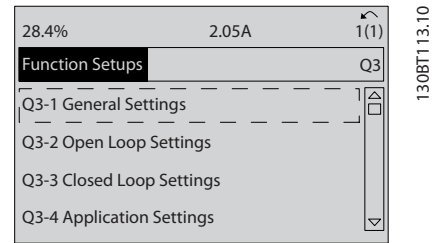

Illustration 6.5

Step 5: Use [▲] and [▼] to scroll down to i.e. Q3-11 Analog Outputs. Press [OK].

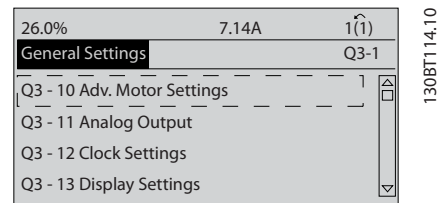

Illustration 6.6

Step 6: Choose 6-50 Terminal 42 Output. Press [OK].

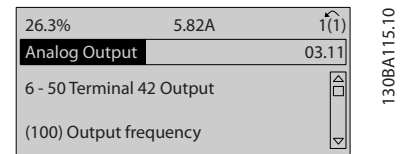

Illustration 6.7

Step 7: Use [▲] and [▼] to select between the different choices. Press [OK].

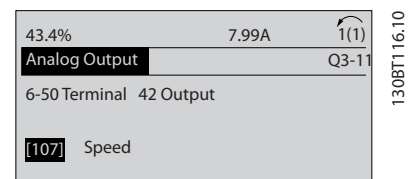

Illustration 6.8

Function Set-ups parameters

The Function Set-ups parameters are grouped in the following way

Q3-1 General Settings			
Q3-10 Adv. Motor Settings	Q3-11 Analog Output	Q3-12 Clock Settings	Q3-13 Display Settings
1-90 Motor Thermal Protection	6-50 Terminal 42 Output	0-70 Date and Time	0-20 Display Line 1.1 Small
1-93 Thermistor Source	6-51 Terminal 42 Output Min Scale	0-71 Date Format	0-21 Display Line 1.2 Small
1-29 Automatic Motor Adaptation (AMA)	6-52 Terminal 42 Output Max Scale	0-72 Time Format	0-22 Display Line 1.3 Small
14-01 Switching Frequency		0-74 DST/Summertime	0-23 Display Line 2 Large
4-53 Warning Speed High		0-76 DST/Summertime Start	0-24 Display Line 3 Large
		0-77 DST/Summertime End	0-37 Display Text 1
			0-38 Display Text 2
			0-39 Display Text 3

Table 6.3

Q3-2 Open Loop Settings	
Q3-20 Digital Reference	Q3-21 Analog Reference
3-02 Minimum Reference	3-02 Minimum Reference
3-03 Maximum Reference	3-03 Maximum Reference
3-10 Preset Reference	6-10 Terminal 53 Low Voltage
5-13 Terminal 29 Digital Input	6-11 Terminal 53 High Voltage
5-14 Terminal 32 Digital Input	6-12 Terminal 53 Low Current
5-15 Terminal 33 Digital Input	6-13 Terminal 53 High Current
	6-14 Terminal 53 Low Ref./Feedb. Value
	6-15 Terminal 53 High Ref./Feedb. Value

Table 6.4

Q3-3 Closed Loop Settings		
Q3-30 Single Zone Int. Set Point	Q3-31 Single Zone Ext. Set Point	Q3-32 Multi Zone / Adv
1-00 Configuration Mode	1-00 Configuration Mode	1-00 Configuration Mode
20-12 Reference/Feedback Unit	20-12 Reference/Feedback Unit	3-15 Reference 1 Source
20-13 Minimum Reference/Feedb.	20-13 Minimum Reference/Feedb.	3-16 Reference 2 Source
20-14 Maximum Reference/Feedb.	20-14 Maximum Reference/Feedb.	20-00 Feedback 1 Source
6-22 Terminal 54 Low Current	6-10 Terminal 53 Low Voltage	20-01 Feedback 1 Conversion
6-24 Terminal 54 Low Ref./Feedb. Value	6-11 Terminal 53 High Voltage	20-02 Feedback 1 Source Unit
6-25 Terminal 54 High Ref./Feedb. Value	6-12 Terminal 53 Low Current	20-03 Feedback 2 Source
6-26 Terminal 54 Filter Time Constant	6-13 Terminal 53 High Current	20-04 Feedback 2 Conversion
6-27 Terminal 54 Live Zero	6-14 Terminal 53 Low Ref./Feedb. Value	20-05 Feedback 2 Source Unit
6-00 Live Zero Timeout Time	6-15 Terminal 53 High Ref./Feedb. Value	20-06 Feedback 3 Source
6-01 Live Zero Timeout Function	6-22 Terminal 54 Low Current	20-07 Feedback 3 Conversion
20-21 Setpoint 1	6-24 Terminal 54 Low Ref./Feedb. Value	20-08 Feedback 3 Source Unit
20-81 PID Normal/ Inverse Control	6-25 Terminal 54 High Ref./Feedb. Value	20-12 Reference/Feedback Unit
20-82 PID Start Speed [RPM]	6-26 Terminal 54 Filter Time Constant	20-13 Minimum Reference/Feedb.
20-83 PID Start Speed [Hz]	6-27 Terminal 54 Live Zero	20-14 Maximum Reference/Feedb.
20-93 PID Proportional Gain	6-00 Live Zero Timeout Time	6-10 Terminal 53 Low Voltage
20-94 PID Integral Time	6-01 Live Zero Timeout Function	6-11 Terminal 53 High Voltage
20-70 Closed Loop Type	20-81 PID Normal/ Inverse Control	6-12 Terminal 53 Low Current
20-71 PID Performance	20-82 PID Start Speed [RPM]	6-13 Terminal 53 High Current
20-72 PID Output Change	20-83 PID Start Speed [Hz]	6-14 Terminal 53 Low Ref./Feedb. Value
20-73 Minimum Feedback Level	20-93 PID Proportional Gain	6-15 Terminal 53 High Ref./Feedb. Value
20-74 Maximum Feedback Level	20-94 PID Integral Time	6-16 Terminal 53 Filter Time Constant
20-79 PID Autotuning	20-70 Closed Loop Type	6-17 Terminal 53 Live Zero
	20-71 PID Performance	6-20 Terminal 54 Low Voltage
	20-72 PID Output Change	6-21 Terminal 54 High Voltage
	20-73 Minimum Feedback Level	6-22 Terminal 54 Low Current
	20-74 Maximum Feedback Level	6-23 Terminal 54 High Current
	20-79 PID Autotuning	6-24 Terminal 54 Low Ref./Feedb. Value
		6-25 Terminal 54 High Ref./Feedb. Value
		6-26 Terminal 54 Filter Time Constant
		6-27 Terminal 54 Live Zero
		6-00 Live Zero Timeout Time
		6-01 Live Zero Timeout Function
		4-56 Warning Feedback Low
		4-57 Warning Feedback High
		20-20 Feedback Function
		20-21 Setpoint 1
		20-22 Setpoint 2
		20-81 PID Normal/ Inverse Control
		20-82 PID Start Speed [RPM]
		20-83 PID Start Speed [Hz]
		20-93 PID Proportional Gain
		20-94 PID Integral Time
		20-70 Closed Loop Type
		20-71 PID Performance
		20-72 PID Output Change
		20-73 Minimum Feedback Level
		20-74 Maximum Feedback Level
		20-79 PID Autotuning

Table 6.5

Q3-4 Application Settings		
Q3-40 Fan Functions	Q3-41 Pump Functions	Q3-42 Compressor Functions
22-60 Broken Belt Function	22-20 Low Power Auto Set-up	1-03 Torque Characteristics
22-61 Broken Belt Torque	22-21 Low Power Detection	1-71 Start Delay
22-62 Broken Belt Delay	22-22 Low Speed Detection	22-75 Short Cycle Protection
4-64 Semi-Auto Bypass Set-up	22-23 No-Flow Function	22-76 Interval between Starts
1-03 Torque Characteristics	22-24 No-Flow Delay	22-77 Minimum Run Time
22-22 Low Speed Detection	22-40 Minimum Run Time	5-01 Terminal 27 Mode
22-23 No-Flow Function	22-41 Minimum Sleep Time	5-02 Terminal 29 Mode
22-24 No-Flow Delay	22-42 Wake-up Speed [RPM]	5-12 Terminal 27 Digital Input
22-40 Minimum Run Time	22-43 Wake-up Speed [Hz]	5-13 Terminal 29 Digital Input
22-41 Minimum Sleep Time	22-44 Wake-up Ref./FB Difference	5-40 Function Relay
22-42 Wake-up Speed [RPM]	22-45 Setpoint Boost	1-73 Flying Start
22-43 Wake-up Speed [Hz]	22-46 Maximum Boost Time	1-86 Trip Speed Low [RPM]
22-44 Wake-up Ref./FB Difference	22-26 Dry Pump Function	1-87 Trip Speed Low [Hz]
22-45 Setpoint Boost	22-27 Dry Pump Delay	
22-46 Maximum Boost Time	22-80 Flow Compensation	
2-10 Brake Function	22-81 Square-linear Curve Approximation	
2-16 AC brake Max. Current	22-82 Work Point Calculation	
2-17 Over-voltage Control	22-83 Speed at No-Flow [RPM]	
1-73 Flying Start	22-84 Speed at No-Flow [Hz]	
1-71 Start Delay	22-85 Speed at Design Point [RPM]	
1-80 Function at Stop	22-86 Speed at Design Point [Hz]	
2-00 DC Hold/Preheat Current	22-87 Pressure at No-Flow Speed	
4-10 Motor Speed Direction	22-88 Pressure at Rated Speed	
	22-89 Flow at Design Point	
	22-90 Flow at Rated Speed	
	1-03 Torque Characteristics	
	1-73 Flying Start	

Table 6.6

1-00 Configuration Mode		
Option:	Function:	
[0] *	Open Loop	Motor speed is determined by applying a speed reference or by setting desired speed when in Hand Mode. Open Loop is also used if the frequency converter is part of a closed loop control system based on an external PID controller providing a speed reference signal as output.
[3]	Closed Loop	Motor Speed will be determined by a reference from the built-in PID controller varying the motor speed as part of a closed loop control process (e.g. constant pressure or flow). The PID controller must be configured in parameter group 20-** or via the Function Setups accessed by pressing [Quick Menus].

NOTE

This parameter cannot be changed while the motor is running.

NOTE

When set for Closed Loop, the commands Reversing and Start Reversing will not reverse the direction of the motor.

1-03 Torque Characteristics		
Option:	Function:	
[0] *	Compressor torque	Compressor [0]: For speed control of screw and scroll compressors. Provides a voltage which is optimized for a constant torque load characteristic of the motor in the entire range down to 10 Hz.
[1]	Variable torque	Variable Torque [1]: For speed control of centrifugal pumps and fans. Also to be used when controlling more than one motor from the same frequency converter (e.g. multiple condenser fans or cooling tower fans). Provides a voltage which is optimized for a squared torque load characteristic of the motor.
[2]	Auto Energy Optim. CT	Auto Energy Optimization Compressor [2]: For optimum energy efficient speed control of screw and scroll compressors. Provides a

1-03 Torque Characteristics	
Option:	Function:
	voltage which is optimized for a constant torque load characteristic of the motor in the entire range down to 15Hz but in addition the AEO feature will adapt the voltage exactly to the current load situation, thereby reducing energy consumption and audible noise from the motor. To obtain optimal performance, the motor power factor $\cos \phi$ must be set correctly. This value is set in <i>14-43 Motor Cosphi</i> . The parameter has a default value which is automatically adjusted when the motor data is programmed. These settings will typically ensure optimum motor voltage but if the motor power factor $\cos \phi$ requires tuning, an AMA function can be carried out using <i>1-29 Automatic Motor Adaptation (AMA)</i> . It is very rarely necessary to adjust the motor power factor parameter manually.
[3] *	Auto Energy Optim. VT <i>Auto Energy Optimization VT</i> [3]: For optimum energy efficient speed control of centrifugal pumps and fans. Provides a voltage which is optimized for a squared torque load characteristic of the motor but in addition the AEO feature will adapt the voltage exactly to the current load situation, thereby reducing energy consumption and audible noise from the motor. To obtain optimal performance, the motor power factor $\cos \phi$ must be set correctly. This value is set in <i>14-43 Motor Cosphi</i> . The parameter has a default value and is automatically adjusted when the motor data is programmed. These settings will typically ensure optimum motor voltage but if the motor power factor $\cos \phi$ requires tuning, an AMA function can be carried out using <i>1-29 Automatic Motor Adaptation (AMA)</i> . It is very rarely necessary to adjust the motor power factor parameter manually.

NOTE

1-03 Torque Characteristics will not have effect when *1-10 Motor Construction* = [1] PM, non salient SPM.

NOTE

For pumps or fan applications where the viscosity or density can vary significantly or where excessive flow e.g. due pipe breakage, can occur, it is recommended to select Auto Energy Optim. CT

1-29 Automatic Motor Adaptation (AMA)	
Option:	Function:
	The AMA function optimizes dynamic motor performance by automatically optimizing the advanced motor <i>1-30 Stator Resistance (Rs)</i> to <i>1-35 Main Reactance (Xh)</i> while the motor is stationary.
[0] *	Off No function
[1]	Enable complete AMA Performs AMA of the stator resistance R_s , the rotor resistance R_r , the stator leakage reactance X_1 , the rotor leakage reactance X_2 and the main reactance X_h .
[2]	Enable reduced AMA Performs a reduced AMA of the stator resistance R_s in the system only. Select this option if an LC filter is used between the frequency converter and the motor.

NOTE

1-29 Automatic Motor Adaptation (AMA) will not have effect when *1-10 Motor Construction* = [1] PM, non salient SPM.

Activate the AMA function by pressing [Hand on] after selecting [1] or [2]. See also the item *Automatic Motor Adaptation* in the Design Guide. After a normal sequence, the display will read: "Press [OK] to finish AMA". After pressing the [OK] key the frequency converter is ready for operation.

NOTE

- For the best adaptation of the frequency converter, run AMA on a cold motor
- AMA cannot be performed while the motor is running

NOTE

Avoid generating external torque during AMA.

NOTE

If one of the settings in parameter group 1-2* Motor Data is changed, *1-30 Stator Resistance (Rs)* to *1-39 Motor Poles*, the advanced motor parameters, will return to default setting.

This parameter cannot be adjusted while the motor is running.

NOTE

Full AMA should be run without filter only while reduced AMA should be run with filter.

See section: *Application Examples > Automatic Motor Adaptation* in the Design Guide.

1-71 Start Delay		
Range:		Function:
0.0 s*	[0.0 - 120.0 s]	The function selected in <i>1-80 Function at Stop</i> is active in the delay period. Enter the time delay required before commencing acceleration.

1-73 Flying Start		
Option:		Function:
		This function makes it possible to catch a motor which is spinning freely due to a mains drop-out. When <i>1-73 Flying Start</i> is enabled, <i>1-71 Start Delay</i> has no function. Search direction for flying start is linked to the setting in <i>4-10 Motor Speed Direction</i> . <i>Clockwise</i> [0]: Flying start search in clockwise direction. If not successful, a DC brake is carried out. <i>Both Directions</i> [2]: The flying start will first make a search in the direction determined by the last reference (direction). If not finding the speed it will make a search in the other direction. If not successful, a DC brake will be activated in the time set in <i>2-02 DC Braking Time</i> . Start will then take place from 0 Hz.
[0]	Disabled	Select [0] <i>Disable</i> if this function is not required
[1]	Enabled	Select [1] <i>Enable</i> to enable the frequency converter to "catch" and control a spinning motor. The parameter is always set to [1] <i>Enable</i> when <i>1-10 Motor Construction</i> = [1] PM non salient. Important related parameters: <ul style="list-style-type: none"> • <i>1-58 Flystart Test Pulses Current</i> • <i>1-59 Flystart Test Pulses Frequency</i> • <i>1-70 PM Start Mode</i> • <i>2-06 Parking Current</i> • <i>2-07 Parking Time</i> • <i>2-03 DC Brake Cut In Speed [RPM]</i> • <i>2-04 DC Brake Cut In Speed [Hz]</i> • <i>2-06 Parking Current</i> • <i>2-07 Parking Time</i>

converter will estimate the rotor position and start normal operation from there.

1-70 PM Start Mode = [1] *Parking*:

If the speed estimate comes out lower than the setting in *1-59 Flystart Test Pulses Frequency* then the *Parking* function will be engaged (see *2-06 Parking Current* and *2-07 Parking Time*). Otherwise the frequency converter will catch the motor at that speed and resume normal operation. Refer to description of *1-70 PM Start Mode* for recommended settings.

Current limitations of the Flystart Principle used for PM motors:

- The speed range is up to 100% Nominal Speed or the field weakening speed (which ever is lowest).
- PMSM with high back emf (>300 VLL(rms)) and high winding inductance(>10 mH) needed more time for reducing short circuit current to zero and may be susceptible to error in estimation.
- Current testing limited to a speed range up to 300 Hz. For certain units the limit is 250 Hz; all 200-240 V units up to and including 2.2 kW and all 380-480 V units up to and including 4 kW.
- Current testing limited to a machine power size up to 22 kW.
- Prepared for salient pole machine (IPMSM) but not yet verified on those types of machine.
- For high inertia applications (i.e. where the load inertia is more than 30 times larger than the motor inertia) a brake resistor is recommended to avoid over-voltage trip during high speed engagement of the fly-start function.

The Flystart function used for PM motors is based on an initial speed estimation. The speed will always be estimated as the first thing after an active start signal is given. Based on the setting of *1-70 PM Start Mode* the following will happen:

1-70 PM Start Mode = [0] *Rotor Detection*:

If the speed estimate comes out as greater than 0 Hz the frequency converter will catch the motor at that speed and resume normal operation. Otherwise, the frequency

1-80 Function at Stop		
Option:	Function:	
		Select the frequency converter function after a stop command or after the speed is ramped down to the settings in <i>1-81 Min Speed for Function at Stop [RPM]</i> . Available selections depend on <i>1-10 Motor Construction</i> : [0] Asynchron: [0] coast [1] DC-hold [2] Motor check, warning [6] Motor check, alarm [1] PM non salient: [0] coast
[0] *	Coast	Leaves motor in free mode.
[1]	DC Hold/ Motor Preheat	Energizes motor with a DC holding current (see <i>2-00 DC Hold/Preheat Current</i>).
[2]	Motor check, warning	Issues a warning if the motor is not connected.
[6]	Motor check, alarm	Issues an alarm if the motor is not connected.

1-90 Motor Thermal Protection		
Option:	Function:	
		The frequency converter determines the motor temperature for motor protection in two different ways: <ul style="list-style-type: none"> Via a thermistor sensor connected to one of the analog or digital inputs (<i>1-93 Thermistor Source</i>). Via calculation (ETR = Electronic Thermal Relay) of the thermal load, based on the actual load and time. The calculated thermal load is comed with the rated motor current $I_{M,N}$ and the rated motor frequency $f_{M,N}$. The calculations estimate the need for a lower load at lower speed due to less cooling from the fan incorporated in the motor.
[0]	No protection	If the motor is continuously overloaded and no warning or trip of frequency converter is wanted.
[1]	Thermistor warning	Activates a warning when the connected thermistor in the motor reacts in the event of motor over-temperature.
[2]	Thermistor trip	Stops (trips) the frequency converter when the connected thermistor in the motor

1-90 Motor Thermal Protection		
Option:	Function:	
		reacts in the event of motor over-temperature.
[3]	ETR warning 1	
[4] *	ETR trip 1	
[5]	ETR warning 2	
[6]	ETR trip 2	
[7]	ETR warning 3	
[8]	ETR trip 3	
[9]	ETR warning 4	
[10]	ETR trip 4	

ETR (Electronic Thermal Relay) functions 1-4 will calculate the load when set-up where they were selected is active. For example ETR-3 starts calculating when set-up 3 is selected. For the North American market: The ETR functions provide class 20 motor overload protection in accordance with NEC.

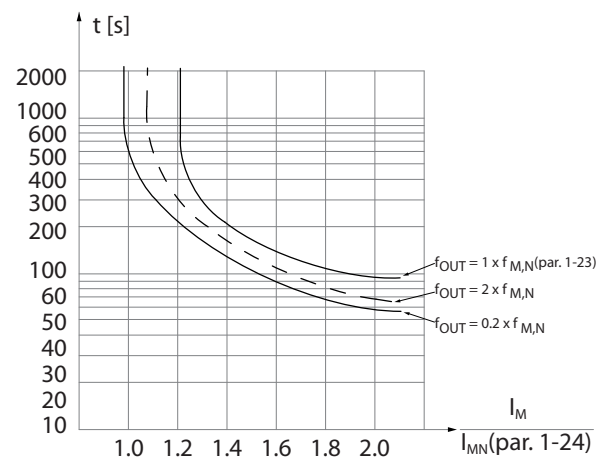

Illustration 6.9

WARNING

In order to maintain PELV, all connections made to the control terminals must be PELV, e.g. thermistor must be reinforced/double insulated

NOTE

Danfoss recommends using 24 V DC as thermistor supply voltage.

NOTE

The ETR timer function does not work when *1-10 Motor Construction* = [1] PM, non salient SPM.

NOTE

For correct operation of ETR function setting in *1-03 Torque Characteristics* must fit the application (see description of *1-03 Torque Characteristics*).

1-93 Thermistor Source		
Option:	Function:	
	Select the input to which the thermistor (PTC sensor) should be connected. An analog input option [1] or [2] cannot be selected if the analog input is already in use as a reference source (selected in <i>3-15 Reference 1 Source</i> , <i>3-16 Reference 2 Source</i> or <i>3-17 Reference 3 Source</i>). When using MCB 112, choice [0] <i>None</i> must always be selected.	
[0] *	None	
[1]	Analog input 53	
[2]	Analog input 54	
[3]	Digital input 18	
[4]	Digital input 19	
[5]	Digital input 32	
[6]	Digital input 33	

NOTE

This parameter cannot be adjusted while the motor is running.

NOTE

Digital input should be set to [0] *PNP - Active at 24 V* in *5-00 Digital I/O Mode*.

2-00 DC Hold/Preheat Current		
Range:	Function:	
50 %* [0 - 160. %]	Enter a value for holding current as a percentage of the rated motor current $I_{M,N}$ set in <i>1-24 Motor Current</i> . 100% DC holding current corresponds to $I_{M,N}$. This parameter holds the motor (holding torque) or pre-heats the motor. This parameter is active if [1] DC hold/Preheat is selected in <i>1-80 Function at Stop</i> .	

NOTE

2-00 DC Hold/Preheat Current will not have effect when *1-10 Motor Construction* = [1] PM, non salient SPM.

NOTE

The maximum value depends on the rated motor current. Avoid 100 % current for too long. It may damage the motor.

2-10 Brake Function		
Option:	Function:	
	Available selections depend on <i>1-10 Motor Construction</i> : [0] Asynchron: [0] off [1] Resistor brake [2] AS brake [1] PM non salient: [0] off [1] Resistor brake	
[0] *	Off	No brake resistor installed.
[1]	Resistor brake	Brake resistor incorporated in the system, for dissipation of surplus brake energy as heat. Connecting a brake resistor allows a higher DC link voltage during braking (generating operation). The Resistor brake function is only active in frequency converters with an integral dynamic brake.
[2]	AC brake	AC Brake will only work in Compressor Torque mode in <i>1-03 Torque Characteristics</i> .

2-17 Over-voltage Control		
Option:	Function:	
[0]	Disabled	No OVC required.
[2] *	Enabled	Activates OVC.

NOTE

2-17 Over-voltage Control will not have effect when *1-10 Motor Construction* = [1] PM, non salient SPM.

NOTE

The ramp time is automatically adjusted to avoid tripping of the frequency converter.

3-02 Minimum Reference		
Range:	Function:	
Size related* [-999999.999 - par. 3-03 Reference-FeedbackUnit]		

3-04 Reference Function		
Option:	Function:	
[0] *	Sum	Sums both external and preset reference sources.
[1]	External/Preset	Use either the preset or the external reference source. Shift between external and preset via a command on a digital input.

6

3-10 Preset Reference		
Array [8]		
Range:	Function:	
0.00 - 100.00 %	[-100.00 - 100.00 %]	
Enter up to eight different preset references (0-7) in this parameter, using array programming. The preset reference is stated as a percentage of the value Ref _{MAX} (3-03 Maximum Reference, for closed loop see 20-14 Maximum Reference/Feedb.). When using preset references, select Preset ref. bit 0 / 1 / 2 [16], [17] or [18] for the corresponding digital inputs in parameter group 5-1* Digital Inputs.		

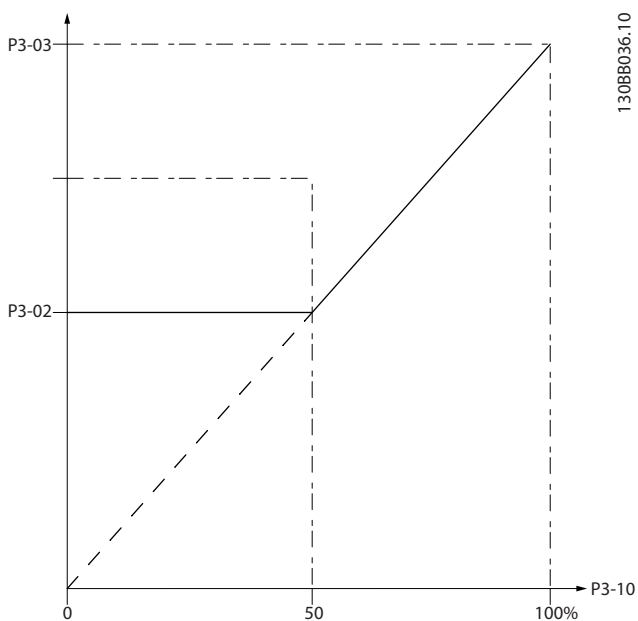

Illustration 6.10

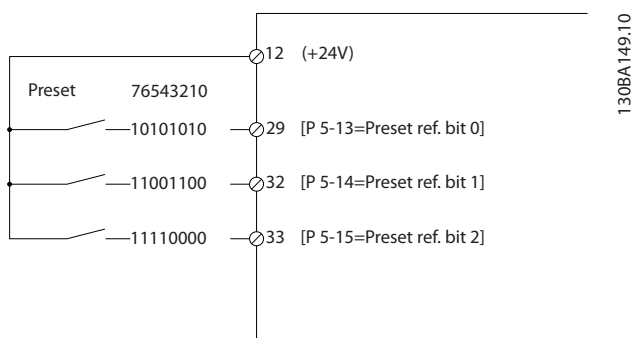

Illustration 6.11

3-15 Reference 1 Source		
Option:	Function:	
	Select the reference input to be used for the first reference signal. 3-15 Reference 1 Source, 3-16 Reference	

3-15 Reference 1 Source		
Option:	Function:	
	2 Source and 3-17 Reference 3 Source define up to three different reference signals. The sum of these reference signals defines the actual reference.	
[0]	No function	
[1] *	Analog input 53	
[2]	Analog input 54	
[7]	Pulse input 29	
[8]	Pulse input 33	
[20]	Digital pot.meter	
[21]	Analog input X30/11	
[22]	Analog input X30/12	
[23]	Analog Input X42/1	
[24]	Analog Input X42/3	
[25]	Analog Input X42/5	
[29]	Analog Input X48/2	
[30]	Ext. Closed Loop 1	
[31]	Ext. Closed Loop 2	
[32]	Ext. Closed Loop 3	

NOTE

This parameter cannot be changed while the motor is running.

3-16 Reference 2 Source		
Option:	Function:	
	Select the reference input to be used for the second reference signal. 3-15 Reference 1 Source, 3-16 Reference 2 Source and 3-17 Reference 3 Source define up to three different reference signals. The sum of these reference signals defines the actual reference.	
[0]	No function	
[1]	Analog input 53	
[2]	Analog input 54	
[7]	Pulse input 29	
[8]	Pulse input 33	
[20] *	Digital pot.meter	
[21]	Analog input X30/11	
[22]	Analog input X30/12	
[23]	Analog Input X42/1	
[24]	Analog Input X42/3	
[25]	Analog Input X42/5	
[29]	Analog Input X48/2	
[30]	Ext. Closed Loop 1	
[31]	Ext. Closed Loop 2	
[32]	Ext. Closed Loop 3	

NOTE

This parameter cannot be changed while the motor is running.

4-10 Motor Speed Direction		
Option:	Function:	
		Selects the motor speed direction required. Use this parameter to prevent unwanted reversing.
[0]	Clockwise	Only operation in clockwise direction will be allowed.
[2] *	Both directions	Operation in both clockwise and anti-clockwise direction will be allowed.

NOTE

The setting in 4-10 Motor Speed Direction has impact on the Flying Start in 1-73 Flying Start.

4-53 Warning Speed High		
Range:	Function:	
Size related*	[par. 4-52 - par. 4-13 RPM]	

NOTE

Any changes in 4-13 Motor Speed High Limit [RPM] will reset the value in 4-53 Warning Speed High to the same value as set in 4-13 Motor Speed High Limit [RPM].

If a different value is needed in 4-53 Warning Speed High, it must be set after programming of 4-13 Motor Speed High Limit [RPM]

4-56 Warning Feedback Low		
Range:	Function:	
-999999.999 ProcessCtrlUnit*	[-999999.999 - par. 4-57 ProcessCtrlUnit]	Enter the lower feedback limit. When the feedback falls below this limit, the display reads Feedb _{Low} . The signal outputs can be programmed to produce a status signal on terminal 27 or 29 and on relay output 01 or 02.

4-57 Warning Feedback High		
Range:	Function:	
999999.999 ProcessCtrlUnit*	[par. 4-56 - 999999.999 ProcessCtrlUnit]	Enter the upper feedback limit. When the feedback exceeds this limit, the display reads Feedb _{High} . The signal outputs can be programmed to produce a status signal on terminal 27 or 29 and on relay output 01 or 02.

4-64 Semi-Auto Bypass Set-up		
Option:	Function:	
[0] *	Off	No function
[1]	Enabled	Starts the Semi-Automatic Bypass set-up and continue with the procedure described above.

5-01 Terminal 27 Mode		
Option:	Function:	
[0] *	Input	Defines terminal 27 as a digital input.
[1]	Output	Defines terminal 27 as a digital output.

NOTE

This parameter cannot be changed while the motor is running.

5-02 Terminal 29 Mode		
Option:	Function:	
[0] *	Input	Defines terminal 29 as a digital input.
[1]	Output	Defines terminal 29 as a digital output.

NOTE

This parameter cannot be changed while the motor is running.

6.1.4 5-1* Digital Inputs

Parameters for configuring the input functions for the input terminals.

The digital inputs are used for selecting various functions in the frequency converter. All digital inputs can be set to the following functions

Digital input function	Select	Terminal
No operation	[0]	All *terminal 19, 32, 33
Reset	[1]	All
Coast inverse	[2]	27
Coast and reset inverse	[3]	All
DC-brake inverse	[5]	All
Stop inverse	[6]	All
External interlock	[7]	All
Start	[8]	All *terminal 18
Latched start	[9]	All
Reversing	[10]	All
Start reversing	[11]	All
Jog	[14]	All *terminal 29
Preset reference on	[15]	All
Preset ref bit 0	[16]	All
Preset ref bit 1	[17]	All
Preset ref bit 2	[18]	All
Freeze reference	[19]	All
Freeze output	[20]	All
Speed up	[21]	All

Digital input function	Select	Terminal
Speed down	[22]	All
Set-up select bit 0	[23]	All
Set-up select bit 1	[24]	All
Pulse input	[32]	terminal 29, 33
Ramp bit 0	[34]	All
Mains failure inverse	[36]	All
Fire mode	[37]	All
Run Permissive	[52]	All
Hand start	[53]	All
Auto start	[54]	All
DigiPot Increase	[55]	All
DigiPot Decrease	[56]	All
DigiPot Clear	[57]	All
Counter A (up)	[60]	29, 33
Counter A (down)	[61]	29, 33
Reset Counter A	[62]	All
Counter B (up)	[63]	29, 33
Counter B (down)	[64]	29, 33
Reset Counter B	[65]	All
Sleep Mode	[66]	All
Reset Maintenance Word	[78]	All
PTC Card 1	[80]	All
Lead Pump Start	[120]	All
Lead Pump Alternation	[121]	All
Pump 1 Interlock	[130]	All
Pump 2 Interlock	[131]	All
Pump 3 Interlock	[132]	All

Table 6.7

5-12 Terminal 27 Digital Input
Option: **Function:**

[2] *	Coast inverse	Functions are described under parameter group 5-1* <i>Digital Inputs</i>
-------	---------------	--

5-13 Terminal 29 Digital Input
Option: **Function:**

		Select the function from the available digital input range and the additional options [60], [61], [63] and [64]. Counters are used in Smart Logic Control functions. This parameter is available for FC 302 only.
[14] *	Jog	Functions are described under parameter group 5-1* <i>Digital Inputs</i>

5-14 Terminal 32 Digital Input
Option: **Function:**

[0] *	No Operation	Same options and functions as parameter group 5-1* <i>Digital Inputs</i> , except for <i>Pulse input</i> .
-------	--------------	--

5-15 Terminal 33 Digital Input
Option: **Function:**

[0] *	No Operation	Same options and functions as parameter group 5-1* <i>Digital Inputs</i> .
-------	--------------	--

5-40 Function Relay

Array [8]

(Relay 1 [0], Relay 2 [1])

Option MCB 105: Relay 7 [6], Relay 8 [7] and Relay 9 [8]).

Select options to define the function of the relays.

The selection of each mechanical relay is realised in an array parameter.

Option:
Function:

Option:	Function:
[0] *	No operation
[1]	Control ready
[2]	Drive ready
[3]	Drive rdy/rem ctrl
[4]	Standby / no warning
[5] *	Running
[6]	Running / no warning
[8]	Run on ref/no warn
[9] *	Alarm
[10]	Alarm or warning
[11]	At torque limit
[12]	Out of current range
[13]	Below current, low
[14]	Above current, high
[15]	Out of speed range
[16]	Below speed, low
[17]	Above speed, high
[18]	Out of feedb. range
[19]	Below feedback, low
[20]	Above feedback, high
[21]	Thermal warning
[25]	Reverse
[26]	Bus OK
[27]	Torque limit & stop
[28]	Brake, no brake war
[29]	Brake ready, no fault
[30]	Brake fault (IGBT)
[35]	External Interlock
[36]	Control word bit 11
[37]	Control word bit 12
[40]	Out of ref range
[41]	Below reference, low
[42]	Above ref, high
[45]	Bus ctrl.
[46]	Bus ctrl, 1 if timeout
[47]	Bus ctrl, 0 if timeout
[60]	Comparator 0
[61]	Comparator 1
[62]	Comparator 2
[63]	Comparator 3
[64]	Comparator 4
[65]	Comparator 5
[70]	Logic rule 0
[71]	Logic rule 1

5-40 Function Relay		
Array [8] (Relay 1 [0], Relay 2 [1]) Option MCB 105: Relay 7 [6], Relay 8 [7] and Relay 9 [8]). Select options to define the function of the relays. The selection of each mechanical relay is realised in an array parameter.		
Option:	Function:	
[72]	Logic rule 2	
[73]	Logic rule 3	
[74]	Logic rule 4	
[75]	Logic rule 5	
[80]	SL digital output A	
[81]	SL digital output B	
[82]	SL digital output C	
[83]	SL digital output D	
[84]	SL digital output E	
[85]	SL digital output F	
[160]	No alarm	
[161]	Running reverse	
[165]	Local ref active	
[166]	Remote ref active	
[167]	Start command act.	
[168]	Hand / Off	
[169]	Auto mode	
[180]	Clock Fault	
[181]	Prev. Maintenance	
[188]	AHF Capacitor Connect	
[189]	External Fan Control	
[190]	No-Flow	
[191]	Dry Pump	
[192]	End Of Curve	
[193]	Sleep Mode	
[194]	Broken Belt	
[195]	Bypass Valve Control	
[196]	Fire Mode	
[197]	Fire Mode was Act.	
[198]	Drive Bypass	
[211]	Cascade Pump 1	
[212]	Cascade Pump 2	
[213]	Cascade Pump 3	

6-00 Live Zero Timeout Time		
Range:	Function:	
10 s* [1 - 99 s]	Enter the Live Zero Time-out time period. Live Zero Time-out Time is active for analog inputs, i.e. terminal 53 or terminal 54, used as reference or feedback sources. If the reference signal value associated with the selected current input falls below 50% of the value set in 6-10 Terminal 53 Low Voltage, 6-12 Terminal 53 Low Current, 6-20 Terminal 54 Low Voltage or 6-22 Terminal 54 Low Current for a time period longer than the time set in 6-00 Live Zero Timeout Time, the function	

6-00 Live Zero Timeout Time		
Range:	Function:	
	selected in 6-01 Live Zero Timeout Function will be activated.	

6-01 Live Zero Timeout Function		
Option:	Function:	
	<p>Select the time-out function. The function set in 6-01 Live Zero Timeout Function will be activated if the input signal on terminal 53 or 54 is below 50% of the value in 6-10 Terminal 53 Low Voltage, 6-12 Terminal 53 Low Current, 6-20 Terminal 54 Low Voltage or 6-22 Terminal 54 Low Current for a time period defined in 6-00 Live Zero Timeout Time. If several time-outs occur simultaneously, the frequency converter prioritises the time-out functions as follows</p> <ol style="list-style-type: none"> 6-01 Live Zero Timeout Function 8-04 Control Timeout Function <p>The output frequency of the frequency converter can be:</p> <ul style="list-style-type: none"> [1] frozen at the present value [2] overruled to stop [3] overruled to jog speed [4] overruled to max. speed [5] overruled to stop with subsequent trip 	
[0] *	Off	
[1]	Freeze output	
[2]	Stop	
[3]	Jogging	
[4]	Max. speed	
[5]	Stop and trip	

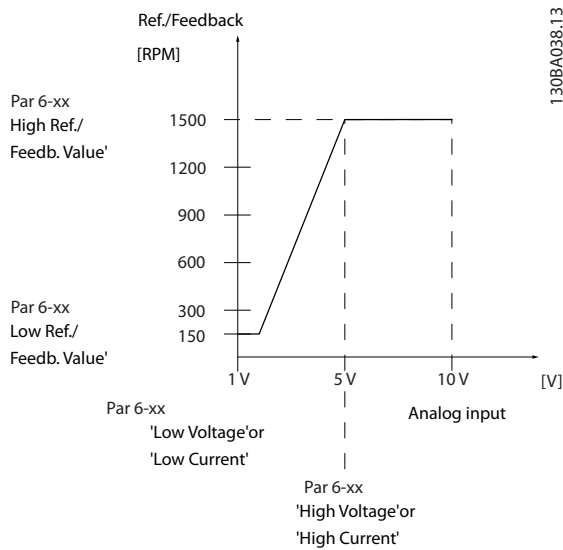

Illustration 6.12

6

6-10 Terminal 53 Low Voltage		
Range:	Function:	
0.07 V* [0.00 - par. 6-11 V]	Enter the low voltage value. This analog input scaling value should correspond to the low reference/feedback value set in 6-14 Terminal 53 Low Ref./Feedb. Value.	

6-11 Terminal 53 High Voltage		
Range:	Function:	
10.00 V* [par. 6-10 - 10.00 V]	Enter the high voltage value. This analog input scaling value should correspond to the high reference/feedback value set in 6-15 Terminal 53 High Ref./Feedb. Value.	

6-14 Terminal 53 Low Ref./Feedb. Value		
Range:	Function:	
0.000 * [-999999.999 - 999999.999]	Enter the analog input scaling value that corresponds to the low voltage/low current set in 6-10 Terminal 53 Low Voltage and 6-12 Terminal 53 Low Current.	

6-15 Terminal 53 High Ref./Feedb. Value		
Range:	Function:	
Size related* [-999999.999 - 999999.999]	Enter the analog input scaling value that corresponds to the high voltage/high current value set in 6-11 Terminal 53 High Voltage and 6-13 Terminal 53 High Current.	

6.1.5 6-16 Terminal 53 Filter Time Constant

6-16 Terminal 53 Filter Time Constant		
Range:	Function:	
0.001 s* [0.001 - 10.000 s]	Enter the time constant. This is a first-order digital low pass filter time constant for suppressing electrical noise in terminal 53. A high time constant value improves dampening but also increases the time delay through the filter.	

NOTE

This parameter cannot be adjusted while the motor is running.

6-17 Terminal 53 Live Zero		
Option:	Function:	
[0]	Disabled	This parameter makes it possible to disable the Live Zero monitoring. E.g. to be used if the analog outputs are used as part of a de-central I/O system (e.g. when not as part of any frequency converter related control functions, but feeding a Building Management system with data).
[1] *	Enabled	

6-20 Terminal 54 Low Voltage		
Range:	Function:	
0.07 V* [0.00 - par. 6-21 V]	Enter the low voltage value. This analog input scaling value should correspond to the low reference/feedback value, set in 6-24 Terminal 54 Low Ref./Feedb. Value.	

6-21 Terminal 54 High Voltage		
Range:	Function:	
10.00 V* [par. 6-20 - 10.00 V]	Enter the high voltage value. This analog input scaling value should correspond to the high reference/feedback value set in 6-25 Terminal 54 High Ref./Feedb. Value.	

6-24 Terminal 54 Low Ref./Feedb. Value		
Range:	Function:	
0.000 * [-999999.999 - 999999.999]	Enter the analog input scaling value that corresponds to the low voltage/low current value set in 6-20 Terminal 54 Low Voltage and 6-22 Terminal 54 Low Current.	

6-25 Terminal 54 High Ref./Feedb. Value		
Range:	Function:	
100.000 * [-999999.999 - 999999.999]	Enter the analog input scaling value that corresponds to the high voltage/high current value set in 6-21 Terminal 54 High Voltage and 6-23 Terminal 54 High Current.	

6-26 Terminal 54 Filter Time Constant		
Range:	Function:	
0.001 s* [0.001 - 10.000 s]	Enter the time constant. This is a first-order digital low pass filter time constant for suppressing electrical noise in terminal 54. A high time constant value improves dampening but also increases the time delay through the filter.	

NOTE

This parameter cannot be adjusted while the motor is running.

6-27 Terminal 54 Live Zero		
Option:	Function:	
	This parameter makes it possible to disable the Live Zero monitoring. E.g. to be used if the analog outputs are used as part of a de-central I/O system (e.g. when not as part of any frequency converter related control functions, but feeding a Building Management System with data).	
[0]	Disabled	
[1] *	Enabled	

6-50 Terminal 42 Output		
Option:	Function:	
	Select the function of Terminal 42 as an analog current output. A motor current of 20 mA corresponds to I_{max} .	
[0]	No operation	
[100]	Output freq. 0-100	0-100 Hz, (0-20 mA)
[101]	Reference Min-Max	Minimum reference - Maximum reference, (0-20 mA)
[102]	Feedback +-200%	-200% to +200% of 20-14 Maximum Reference/Feedb., (0-20 mA)
[103]	Motor cur. 0- I_{max}	0 - Inverter Max. Current (16-37 Inv. Max. Current), (0-20 mA)
[104]	Torque 0-Tlim	0 - Torque limit (4-16 Torque Limit Motor Mode), (0-20 mA)
[105]	Torque 0-Tnom	0 - Motor rated torque, (0-20 mA)

6-50 Terminal 42 Output		
Option:	Function:	
[106]	Power 0-Pnom	0 - Motor rated power, (0-20 mA)
[107]	Speed 0-HighLim	0 - Speed High Limit (4-13 Motor Speed High Limit [RPM] and 4-14 Motor Speed High Limit [Hz]), (0-20 mA)
[113]	Ext. Closed Loop 1	0-100%, (0-20 mA)
[114]	Ext. Closed Loop 2	0-100%, (0-20 mA)
[115]	Ext. Closed Loop 3	0-100%, (0-20 mA)
[130]	Out frq 0-100 4-20mA	0-100 Hz
[131]	Reference 4-20mA	Minimum Reference - Maximum Reference
[132]	Feedback 4-20mA	-200% to +200% of 20-14 Maximum Reference/Feedb.
[133]	Motor cur. 4-20mA	0 - Inverter Max. Current (16-37 Inv. Max. Current)
[134]	Torq.0-lim 4-20 mA	0 - Torque limit (4-16 Torque Limit Motor Mode)
[135]	Torq.0-nom 4-20mA	0 - Motor rated torque
[136]	Power 4-20mA	0 - Motor rated power
[137] *	Speed 4-20mA	0 - Speed High Limit (4-13 and 4-14)
[139]	Bus ctrl.	0-100%, (0-20 mA)
[140]	Bus ctrl. 4-20 mA	0-100%
[141]	Bus ctrl t.o.	0-100%, (0-20 mA)
[142]	Bus ctrl t.o. 4-20mA	0-100%
[143]	Ext. CL 1 4-20mA	0-100%
[144]	Ext. CL 2 4-20mA	0-100%
[145]	Ext. CL 3 4-20mA	0-100%

NOTE

Values for setting the Minimum Reference is found in open loop 3-02 Minimum Reference and for closed loop 20-13 Minimum Reference/Feedb. - values for maximum reference for open loop is found in 3-03 Maximum Reference and for closed loop 20-14 Maximum Reference/Feedb..

6.1.6 6-51 Terminal 42 Output Min Scale

6-51 Terminal 42 Output Min Scale		
Range:	Function:	
0.00 %* [0.00 - 200.00 %]	Scale for the minimum output (0 or 4 mA) of the analog signal at terminal 42. Set the value to be the percentage of the full range of the variable selected in 6-50 Terminal 42 Output.	

6-52 Terminal 42 Output Max Scale		
Range:	Function:	
100.00 %*	[0.00 - 200.00 %]	Scale for the maximum output (20mA) of the analog signal at terminal 42. Set the value to be the percentage of the full range of the variable selected in 6-50 Terminal 42 Output.
		<p>130BA075.12</p> <p>0% Analogue output Min Scale par. 6-93</p> <p>Analogue Output Max Scale par. 6-94</p> <p>100% Variable for output example: Speed (RPM)</p>
		Illustration 6.13
		It is possible to get a value lower than 20mA at full scale by programming values >100% by using a formula as follows:

$20\text{ mA} \mid \text{desired maximum current} \times 100\%$

i.e. $10\text{ mA} : \frac{20\text{ mA}}{10\text{ mA}} \times 100\% = 200\%$

EXAMPLE 1:

Variable value= OUTPUT FREQUENCY, range = 0-100 Hz
 Range needed for output = 0-50 Hz
 Output signal 0 or 4mA is needed at 0 Hz (0% of range) - set 6-51 Terminal 42 Output Min Scale to 0%
 Output signal 20 mA is needed at 50 Hz (50% of range) - set 6-52 Terminal 42 Output Max Scale to 50%

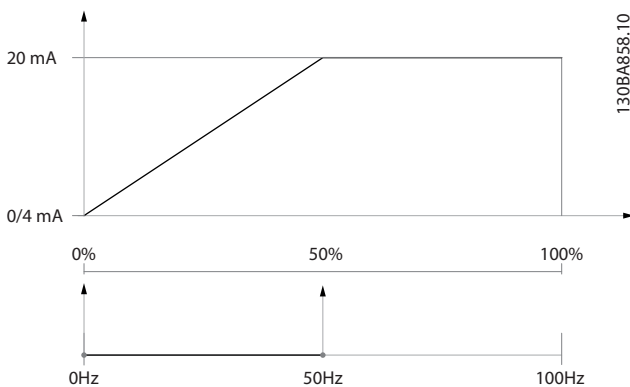

Illustration 6.14

EXAMPLE 2:

Variable= FEEDBACK, range= -200% to +200%
 Range needed for output= 0-100%
 Output signal 0 or 4 mA is needed at 0% (50% of range) - set 6-51 Terminal 42 Output Min Scale to 50%

Output signal 20 mA is needed at 100% (75% of range) - set 6-52 Terminal 42 Output Max Scale to 75%

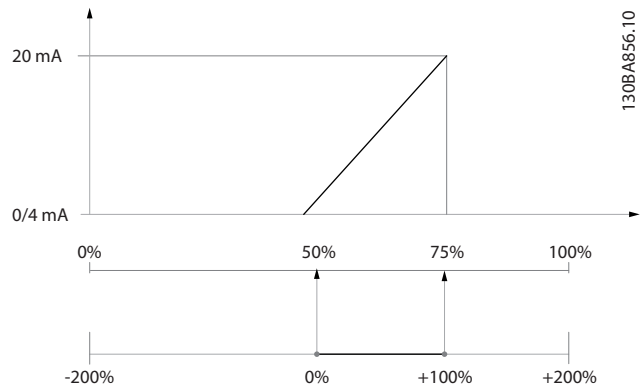

Illustration 6.15

EXAMPLE 3:

Variable value= REFERENCE, range= Min ref - Max ref
 Range needed for output= Min ref (0%) - Max ref (100%), 0-10 mA
 Output signal 0 or 4 mA is needed at Min ref - set 6-51 Terminal 42 Output Min Scale to 0%
 Output signal 10 mA is needed at Max ref (100% of range) - set 6-52 Terminal 42 Output Max Scale to 200% (20 mA/10 mA x 100%=200%).

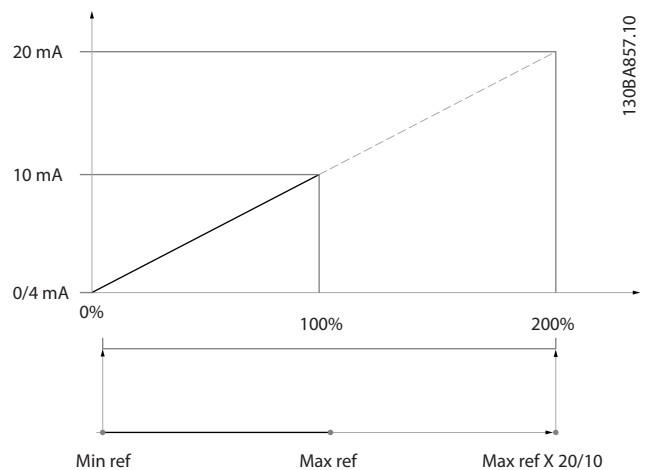

Illustration 6.16

14-01 Switching Frequency		
Option:	Function:	
	Select the inverter switching frequency. Changing the switching frequency can help to reduce acoustic noise from the motor.	

14-01 Switching Frequency	
Option:	Function:
	<p>NOTE</p> <p>The output frequency value of the frequency converter must never exceed 1/10 of the switching frequency. When the motor is running, adjust the switching frequency in <i>14-01 Switching Frequency</i> until the motor is as noiseless as possible. See also <i>14-00 Switching Pattern</i> and the section <i>Derating</i>.</p>
[0]	1.0 kHz
[1]	1.5 kHz
[2]	2.0 kHz
[3]	2.5 kHz
[4]	3.0 kHz
[5]	3.5 kHz
[6]	4.0 kHz
[7] *	5.0 kHz
[8]	6.0 kHz
[9]	7.0 kHz
[10]	8.0 kHz
[11]	10.0 kHz
[12]	12.0 kHz
[13]	14.0 kHz
[14]	16.0 kHz

20-00 Feedback 1 Source	
Option:	Function:
	<p>Up to three different feedback signals can be used to provide the feedback signal for the frequency converter's PID Controller.</p> <p>This parameter defines which input will be used as the source of the first feedback signal.</p> <p>Analog input X30/11 and Analog input X30/12 refer to inputs on the optional General Purpose I/O board.</p>
[0]	No function
[1]	Analog input 53
[2] *	Analog input 54
[3]	Pulse input 29
[4]	Pulse input 33
[7]	Analog input X30/11
[8]	Analog input X30/12
[9]	Analog Input X42/1
[10]	Analog Input X42/3
[11]	Analog Input X42/5
[15]	Analog Input X48/2
[100]	Bus feedback 1
[101]	Bus feedback 2
[102]	Bus feedback 3

20-00 Feedback 1 Source	
Option:	Function:
[104]	<p>Sensorless Flow</p> <p>Requires set up by MCT 10 Set-up Software with sensorless specific plug in.</p>
[105]	<p>Sensorless Pressure</p> <p>Requires set up by MCT 10 Set-up Software with sensorless specific plug in.</p>

NOTE

If a feedback is not used, its source must be set to [0] *No Function*. *20-20 Feedback Function* determines how the three possible feedbacks will be used by the PID Controller.

20-01 Feedback 1 Conversion	
Option:	Function:
	<p>This parameter allows a conversion function to be applied to Feedback 1.</p>
[0]	<p>Linear</p> <p><i>Linear</i> [0] has no effect on the feedback.</p>
[1]	<p>Square root</p> <p><i>Square root</i> [1] is commonly used when a pressure sensor is used to provide flow feedback</p> <p>((<i>flow</i> ∝ √<i>pressure</i>)).</p>
[2]	<p>Pressure to temperature</p> <p><i>Pressure to temperature</i> [2] is used in compressor applications to provide temperature feedback using a pressure sensor. The temperature of the refrigerant is calculated using the following formula:</p> $Temperature = \frac{A2}{(\ln(Pe + 1) - A1)} - A3,$ <p>where A1, A2 and A3 are refrigerant-specific constants. The refrigerant must be selected in <i>20-30 Refrigerant</i>. <i>20-21 Setpoint 1</i> through <i>20-23 Setpoint 3</i> allow the values of A1, A2 and A3 to be entered for a refrigerant that is not listed in <i>20-30 Refrigerant</i>.</p>
[3]	<p>Pressure to flow</p> <p>Pressure to flow is used in applications where the air flow in a duct is to be controlled. The feedback signal is represented by a dynamic pressure measurement (pitot tube).</p> $Flow = Duct\ Area \times \sqrt{Dynamic\ Pressure}$ <p>× <i>Air Density Factor</i></p> <p>See also <i>20-34 Duct 1 Area [m2]</i> through <i>20-38 Air Density Factor [%]</i> for setting of duct area and air density.</p>
[4]	<p>Velocity to flow</p> <p>Velocity to flow is used in applications where the air flow in a duct is to be controlled. The feedback signal is represented by an air velocity measurement.</p> $Flow = Duct\ Area \times Air\ Velocity$ <p>See also <i>20-34 Duct 1 Area [m2]</i> through <i>20-37 Duct 2 Area [in2]</i> for setting of duct area.</p>

20-03 Feedback 2 Source		
Option:	Function:	
		See 20-00 Feedback 1 Source for details.
[0] *	No function	
[1]	Analog input 53	
[2]	Analog input 54	
[3]	Pulse input 29	
[4]	Pulse input 33	
[7]	Analog input X30/11	
[8]	Analog input X30/12	
[9]	Analog Input X42/1	
[10]	Analog Input X42/3	
[11]	Analog Input X42/5	
[15]	Analog Input X48/2	
[100]	Bus feedback 1	
[101]	Bus feedback 2	
[102]	Bus feedback 3	

20-04 Feedback 2 Conversion		
Option:	Function:	
		See 20-01 Feedback 1 Conversion for details.
[0] *	Linear	
[1]	Square root	
[2]	Pressure to temperature	
[3]	Pressure to flow	
[4]	Velocity to flow	

20-06 Feedback 3 Source		
Option:	Function:	
		See 20-00 Feedback 1 Source for details.
[0] *	No function	
[1]	Analog input 53	
[2]	Analog input 54	
[3]	Pulse input 29	
[4]	Pulse input 33	
[7]	Analog input X30/11	
[8]	Analog input X30/12	
[9]	Analog Input X42/1	
[10]	Analog Input X42/3	
[11]	Analog Input X42/5	
[15]	Analog Input X48/2	
[100]	Bus feedback 1	
[101]	Bus feedback 2	
[102]	Bus feedback 3	

20-07 Feedback 3 Conversion		
Option:	Function:	
		See 20-01 Feedback 1 Conversion for details.
[0] *	Linear	

20-07 Feedback 3 Conversion		
Option:	Function:	
[1]	Square root	
[2]	Pressure to temperature	
[3]	Pressure to flow	
[4]	Velocity to flow	

20-20 Feedback Function		
Option:	Function:	
		This parameter determines how the three possible feedbacks will be used to control the output frequency of the frequency converter.
[0]	Sum	<p><i>Sum</i> [0] sets up the PID Controller to use the sum of Feedback 1, Feedback 2 and Feedback 3 as the feedback.</p> <p>NOTE Any unused feedbacks must be set to <i>No Function</i> in 20-00 Feedback 1 Source, 20-03 Feedback 2 Source, or 20-06 Feedback 3 Source.</p> <p>The sum of Setpoint 1 and any other references that are enabled (see parameter group 3-1*) will be used as the PID Controller's set-point reference.</p>
[1]	Difference	<p><i>Difference</i> [1] sets up the PID controller to use the difference between Feedback 1 and Feedback 2 as the feedback. Feedback 3 will not be used with this selection. Only Setpoint 1 will be used. The sum of Setpoint 1 and any other references that are enabled (see parameter group 3-1*) will be used as the PID controller's set-point reference.</p>
[2]	Average	<p><i>Average</i> [2] sets up the PID Controller to use the average of Feedback 1, Feedback 2 and Feedback 3 as the feedback.</p> <p>NOTE Any unused feedbacks must be set to <i>No Function</i> in 20-00 Feedback 1 Source, 20-03 Feedback 2 Source, or 20-06 Feedback 3 Source. The sum of Setpoint 1 and any other references that are enabled (see parameter group 3-1*) will be used as the PID Controller's set-point reference.</p>
[3]	Minimum	<p><i>Minimum</i> [3] sets up the PID Controller to compare Feedback 1, Feedback 2 and Feedback 3 and use the lowest value as the feedback.</p>

20-20 Feedback Function		
Option:	Function:	
		<p>NOTE Any unused feedbacks must be set to <i>No Function</i> in <i>20-00 Feedback 1 Source</i>, <i>20-03 Feedback 2 Source</i>, or <i>20-06 Feedback 3 Source</i>. Only setpoint 1 will be used. The sum of Setpoint 1 and any other references that are enabled (see parameter group 3-1*) will be used as the PID Controller's setpoint reference.</p>
[4]	Maximum	<p><i>Maximum</i> [4] sets up the PID Controller to compare Feedback 1, Feedback 2 and Feedback 3 and use the highest value as the feedback.</p> <p>NOTE Any unused feedbacks must be set to <i>No Function</i> in <i>20-00 Feedback 1 Source</i>, <i>20-03 Feedback 2 Source</i>, or <i>20-06 Feedback 3 Source</i>.</p> <p>Only Setpoint 1 will be used. The sum of Setpoint 1 and any other references that are enabled (see parameter group 3-1*) will be used as the PID Controller's setpoint reference.</p>
[5]	Multi Setpoint Min	<p><i>Multi-setpoint minimum</i> [5] sets up the PID Controller to calculate the difference between Feedback 1 and Setpoint 1, Feedback 2 and Setpoint 2, and Feedback 3 and Setpoint 3. It will use the feedback/setpoint pair in which the feedback is the farthest below its corresponding setpoint reference. If all feedback signals are above their corresponding setpoints, the PID Controller will use the feedback/setpoint pair in which the difference between the feedback and setpoint is the least.</p> <p>NOTE If only two feedback signals are used, the feedback that is not to be used must be set to <i>No Function</i> in <i>20-00 Feedback 1 Source</i>, <i>20-03 Feedback 2 Source</i> or <i>20-06 Feedback 3 Source</i>. Note that each setpoint reference will be the sum of its respective parameter value (<i>20-21 Setpoint 1</i>, <i>20-22 Setpoint 2</i> and <i>20-23 Setpoint 3</i>) and any other references that are enabled (see parameter group 3-1*).</p>
[6]	Multi Setpoint Max	<p><i>Multi-setpoint maximum</i> [6] sets up the PID Controller to calculate the difference between Feedback 1 and Setpoint 1, Feedback 2 and Setpoint 2, and Feedback 3 and Setpoint 3. It will use the feedback/setpoint pair in which the feedback is farthest above its corresponding</p>

20-20 Feedback Function	
Option:	Function:
	<p>setpoint reference. If all feedback signals are below their corresponding setpoints, the PID Controller will use the feedback/setpoint pair in which the difference between the feedback and the setpoint reference is the least.</p> <p>NOTE If only two feedback signals are used, the feedback that is not to be used must be set to <i>No Function</i> in <i>20-00 Feedback 1 Source</i>, <i>20-03 Feedback 2 Source</i> or <i>20-06 Feedback 3 Source</i>. Note that each setpoint reference will be the sum of its respective parameter value (<i>20-21 Setpoint 1</i>, <i>20-22 Setpoint 2</i> and <i>20-23 Setpoint 3</i>) and any other references that are enabled (see parameter group 3-1*).</p>

NOTE

Any unused feedback must be set to "No function" in its Feedback Source parameter: *20-00 Feedback 1 Source*, *20-03 Feedback 2 Source* or *20-06 Feedback 3 Source*.

The feedback resulting from the function selected in *20-20 Feedback Function* will be used by the PID Controller to control the output frequency of the frequency converter. This feedback can also be shown on the frequency converter's display, be used to control a frequency converter's analog output, and be transmitted over various serial communication protocols.

The frequency converter can be configured to handle multi zone applications. Two different multi zone applications are supported:

- Multi zone, single setpoint
- Multi zone, multi setpoint

The difference between the two is illustrated by the following examples:

Example 1 – Multi zone, single setpoint

In an office building, a VAV (variable air volume) VLT HVAC Drive system must ensure a minimum pressure at selected VAV boxes. Due to the varying pressure losses in each duct, the pressure at each VAV box cannot be assumed to be the same. The minimum pressure required is the same for all VAV boxes. This control method can be set up by setting *20-20 Feedback Function* to option [3], Minimum, and entering the desired pressure in *20-21 Setpoint 1*. The PID Controller will increase the speed of the fan if any one feedback is below the setpoint and decrease the speed of the fan if all feedbacks are above the setpoint.

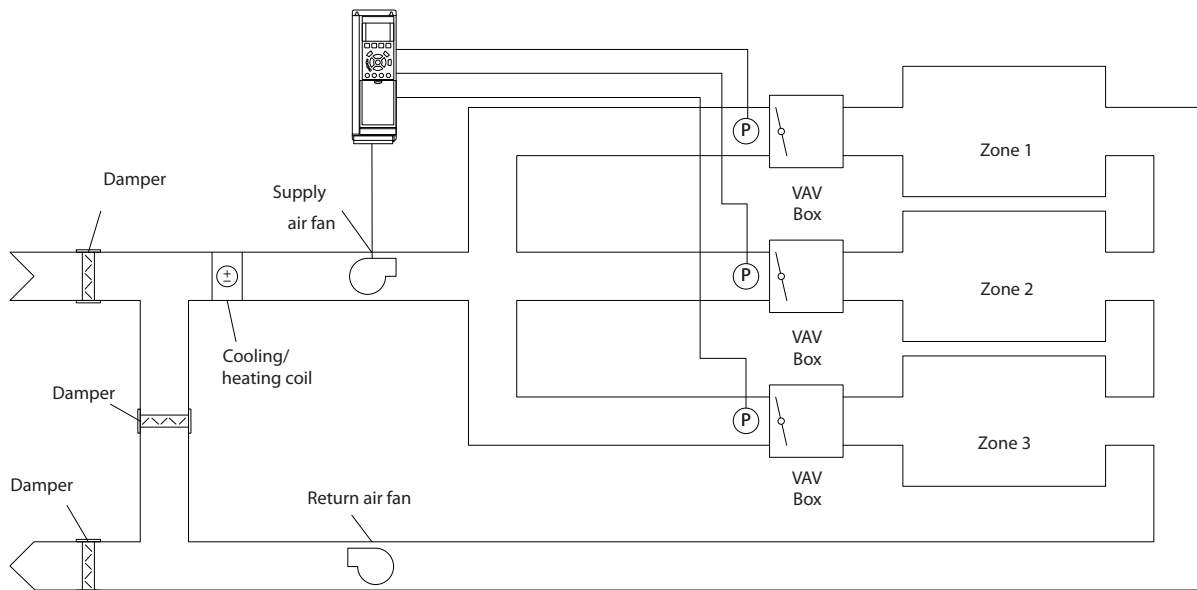

130BA353:10

Illustration 6.17

6

Example 2 – Multi zone, multi setpoint

The previous example can be used to illustrate the use of multi zone, multi setpoint control. If the zones require different pressures for each VAV box, each setpoint may be specified in 20-21 Setpoint 1, 20-22 Setpoint 2 and 20-23 Setpoint 3. By selecting *Multi setpoint minimum*, [5], in 20-20 Feedback Function, the PID Controller will increase the speed of the fan if any one of the feedbacks is below its setpoint and decrease the speed of the fan if all feedbacks are above their individual setpoints.

20-21 Setpoint 1		
Range:	Function:	
0.000 ProcessCtrlUnit*	[par. 20-13 - par. 20-14 ProcessCtrlUnit]	Setpoint 1 is used in Closed Loop Mode to enter a setpoint reference that is used by the frequency converter's PID Controller. See the description of 20-20 Feedback Function. NOTE Setpoint reference entered here is added to any other references that are enabled (see parameter group 3-1*).

20-22 Setpoint 2		
Range:	Function:	
0.000 ProcessCtrlUnit*	[par. 20-13 - par. 20-14 ProcessCtrlUnit]	Setpoint 2 is used in Closed Loop Mode to enter a setpoint reference that may be used by the frequency converter's PID

20-22 Setpoint 2		
Range:	Function:	
		Controller. See the description of Feedback Function, 20-20 Feedback Function.

NOTE

The set-point reference entered here is added to any other references that are enabled (see parameter group 3-1*).

20-81 PID Normal/ Inverse Control		
Option:	Function:	
[0] *	Normal	[0] Normal causes the frequency converter's output frequency to decrease when the feedback is greater than the setpoint reference. This is common for pressure-controlled supply fan and pump applications.
[1]	Inverse	[1] Inverse causes the frequency converter's output frequency to increase when the feedback is greater than the setpoint reference. This is common for temperature-controlled cooling applications, such as cooling towers.

20-93 PID Proportional Gain		
Range:	Function:	
0.50 *	[0.00 - 10.00]	The proportional gain indicates the number of times the error between the set point and the feedback signal is to be applied.

If (Error x Gain) jumps with a value equal to what is set in 20-14 Maximum Reference/Feedb. the PID controller will try

to change the output speed equal to what is set in 4-13 Motor Speed High Limit [RPM]/4-14 Motor Speed High Limit [Hz] but in practice of course limited by this setting. The proportional band (error causing output to change from 0-100%) can be calculated by means of the formula

$$\left(\frac{1}{\text{Proportional Gain}}\right) \times (\text{Max Reference})$$

NOTE

Always set the desired for 20-14 Maximum Reference/Feedb. before setting the values for the PID controller in parameter group 20-9*.

20-94 PID Integral Time		
Range:	Function:	
20.00 s* s	[0.01 - 10000.00 s]	Over time, the integrator accumulates a contribution to the output from the PID controller as long as there is a deviation between the Reference/Setpoint and feedback signals. The contribution is proportional to the size of the deviation. This ensures that the deviation (error) approaches zero. Quick response on any deviation is obtained when the integral time is set to a low value. Setting it too low, however, may cause the control to become unstable. The value set, is the time needed for the integrator to add the same contribution as the proportional for a certain deviation. If the value is set to 10,000, the controller will act as a pure proportional controller with a P-band based on the value set in 20-93 PID Proportional Gain. When no deviation is present, the output from the proportional controller will be 0.

22-21 Low Power Detection		
Option:	Function:	
[0] * Disabled		
[1] Enabled	If selecting Enabled, the Low Power Detection commissioning must be carried out in order to set the parameters in parameter group 22-3* for proper operation!	

22-22 Low Speed Detection		
Option:	Function:	
[0] * Disabled		
[1] Enabled	Select Enabled for detecting when the motor operates with a speed as set in 4-11 Motor Speed Low Limit [RPM] or 4-12 Motor Speed Low Limit [Hz].	

22-23 No-Flow Function		
Common actions for Low Power Detection and Low Speed Detection (Individual selections not possible).		
Option:	Function:	
[0] * Off		
[1] Sleep Mode	The frequency converter will enter Sleep Mode and stop when a No Flow condition is detected. See parameter group 22-4* for programming options for Sleep Mode.	
[2] Warning	The frequency converter will continue to run, but activate a No-Flow Warning [W92]. A drive digital output or a serial communication bus can communicate a warning to other equipment.	
[3] Alarm	The frequency converter will stop running and activate a No-Flow Alarm [A 92]. A frequency converter digital output or a serial communication bus can communicate an alarm to other equipment.	

NOTE

Do not set 14-20 Reset Mode, to [13] Infinite auto reset, when 22-23 No-Flow Function is set to [3] Alarm. Doing so will cause the frequency converter to continuously cycle between running and stopping when a No Flow condition is detected.

NOTE

If the frequency converter is equipped with a constant speed bypass with an automatic bypass function that starts the bypass if the frequency converter experiences a persistent alarm condition, be sure to disable the bypass's automatic bypass function, if [3] Alarm is selected as the No-Flow Function.

22-24 No-Flow Delay		
Range:	Function:	
10 s* s	[1 - 600 s]	Set the time Low Power/Low Speed must stay detected to activate signal for actions. If detection disappears before run out of the timer, the timer will be reset.

22-26 Dry Pump Function		
Select desired action for dry pump operation.		
Option:	Function:	
[0] *	Off	
[1]	Warning	The frequency converter will continue to run, but activate a Dry pump warning [W93]. A frequency converter digital output or a serial communication bus can communicate a warning to other equipment.
[2]	Alarm	The frequency converter will stop running and activate a Dry pump alarm [A93]. A frequency converter digital output or a serial communication bus can communicate an alarm to other equipment.
[3]	Man. Reset Alarm	The frequency converter will stop running and activate a Dry pump alarm [A93]. A frequency converter digital output or a serial communication bus can communicate an alarm to other equipment.

NOTE

Low Power Detection must be Enabled (22-21 Low Power Detection) and commissioned (using either parameter group 22-3*, No Flow Power Tuning, or 22-20 Low Power Auto Set-up) in order to use Dry Pump Detection.

NOTE

Do not set 14-20 Reset Mode, to [13] Infinite auto reset, when 22-26 Dry Pump Function is set to [2] Alarm. Doing so will cause the frequency converter to continuously cycle between running and stopping when a Dry Pump condition is detected.

NOTE

If the frequency converter is equipped with a constant speed bypass with an automatic bypass function that starts the bypass if the frequency converter experiences a persistent alarm condition, be sure to disable the bypass's automatic bypass function, if [2] Alarm or [3] Man. Reset Alarm is selected as the Dry Pump Function.

22-40 Minimum Run Time		
Range:	Function:	
10 s*	[0 - 600 s]	Set the desired minimum running time for the motor after a start command (digital input or Bus) before entering Sleep Mode.

22-41 Minimum Sleep Time		
Range:	Function:	
10 s*	[0 - 600 s]	Set the desired Minimum Time for staying in Sleep Mode. This will override any wake up conditions.

22-42 Wake-up Speed [RPM]		
Range:	Function:	
Size related*	[par. 4-11 - par. 4-13 RPM]	To be used if 0-02 Motor Speed Unit has been set for RPM (parameter not visible if Hz selected). Only to be used if 1-00 Configuration Mode is set for Open Loop and speed reference is applied by an external controller. Set the reference speed at which the Sleep Mode should be cancelled.

22-60 Broken Belt Function		
Selects the action to be performed if the Broken Belt condition is detected		
Option:	Function:	
[0] *	Off	
[1]	Warning	The frequency converter will continue to run, but activate a Broken Belt Warning [W95]. A frequency converter digital output or a serial communication bus can communicate a warning to other equipment.
[2]	Trip	The frequency converter will stop running and activate a Broken Belt alarm [A 95]. A frequency converter digital output or a serial communication bus can communicate an alarm to other equipment.

NOTE

Do not set 14-20 Reset Mode, to [13] Infinite auto reset, when 22-60 Broken Belt Function is set to [2] Trip. Doing so will cause the frequency converter to continuously cycle between running and stopping when a broken belt condition is detected.

NOTE

If the frequency converter is equipped with a constant speed bypass with an automatic bypass function that starts the bypass if the frequency converter experiences a persistent alarm condition, be sure to disable the bypass's automatic bypass function, if [2] Trip is selected as the Broken Belt Function.

22-61 Broken Belt Torque		
Range:	Function:	
10 %*	[0 - 100 %]	Sets the broken belt torque as a percentage of the rated motor torque.

22-62 Broken Belt Delay		
Range:	Function:	
10 s	[0 - 600 s]	Sets the time for which the Broken Belt conditions must be active before carrying out the action selected in 22-60 Broken Belt Function.

22-75 Short Cycle Protection		
Option:	Function:	
[0] *	Disabled	Timer set in 22-76 Interval between Starts is disabled.
[1]	Enabled	Timer set in 22-76 Interval between Starts is enabled.

22-76 Interval between Starts		
Range:	Function:	
Size related* [par. 22-77 - 3600 s]	Sets the time desired as minimum time between two starts. Any normal start command (Start/Jog/Freeze) will be disregarded until the timer has expired.	

22-77 Minimum Run Time		
Range:	Function:	
0 s* [0 - par. 22-76 s]	Sets the time desired as minimum run time after a normal start command (Start/Jog/Freeze). Any normal stop command will be disregarded until the set time has expired. The timer will start counting following a normal start command (Start/Jog/Freeze). The timer will be overridden by a Coast (Inverse) or an External Interlock command.	

NOTE

Does not work in cascade mode.

6.1.7 Main Menu Mode

Both the GLCP and NLCP provide access to the main menu mode. Select the Main Menu mode by pressing the [Main Menu] key. *Illustration 6.18* shows the resulting read-out, which appears on the display of the GLCP. Lines 2 through 5 on the display show a list of parameter groups which can be chosen by toggling the up and down buttons.

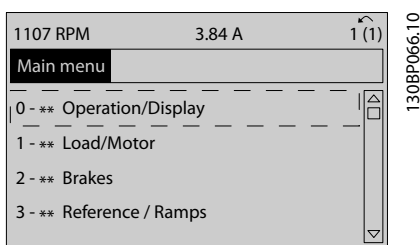

Illustration 6.18 Display Example

Each parameter has a name and number which remain the same regardless of the programming mode. In the Main Menu mode, the parameters are divided into groups. The

first digit of the parameter number (from the left) indicates the parameter group number.

All parameters can be changed in the Main Menu. The configuration of the unit (1-00 Configuration Mode) will determine other parameters available for programming. For example, selecting Closed Loop enables additional parameters related to closed loop operation. Option cards added to the unit enable additional parameters associated with the option device.

6.1.8 Parameter Selection

In the Main Menu mode, the parameters are divided into groups. Select a parameter group by means of the navigation keys.

The following parameter groups are accessible:

Group no.	Parameter group:
0-**	Operation/Display
1-**	Load/Motor
2-**	Brakes
3-**	References/Ramps
4-**	Limits/Warnings
5-**	Digital In/Out
6-**	Analog In/Out
8-**	Comm. and Options
9-**	Profibus
10-**	CAN Fieldbus
11-**	LonWorks
13-**	Smart Logic
14-**	Special Functions
15-**	FC Information
16-**	Data Readouts
18-**	Data Readouts 2
20-**	FC Closed Loop
21-**	Ext. Closed Loop
22-**	Application Functions
23-**	Time Actions
25-**	Cascade Controller
26-**	Analog I/O Option MCB 109
27-**	Cascade CTL Option
29-**	Water Application Functions
31-**	Bypass Option

Table 6.8

After selecting a parameter group, choose a parameter by means of the navigation keys.

The middle section on the GLCP display shows the parameter number and name as well as the selected parameter value.

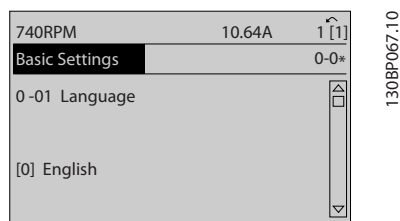

Illustration 6.19 Display Example

frequency, voltage levels and other values directly linked to the drive configuration are pre-set.

It is not recommended to change any other parameters influencing the filter operation. However, selection of read-outs and what information to be displayed on the LCP status lines can be made to fit individual preferences.

To set up the filter two steps are necessary:

- Change the nominal voltage in *300-10 Active Filter Nominal Voltage*
- Make sure the filter is in auto mode (press [Auto On])

6.2 How to Programme the Active Filter

The factory settings for the filter part of the Low Harmonic Drive are chosen for optimal operation with a minimum of additional programming. All CT-values, as well as

6

Group	Title	Function
0-**	Operation/Display	Parameters related to the fundamental functions of the filter, function of the LCP buttons and configuration of the LCP display.
5-**	Digital In/Out	Parameter group for configuring the digital inputs and outputs.
8-**	Communication and Options	Parameter group for configuring communications and options.
14-**	Special Functions	Parameter group for configuring special functions.
15-**	Unit Information	Parameter group containing active filter information such as operating data, hardware configuration and software versions.
16-**	Data Readouts	Parameter group for data read-outs, e.g. actual references, voltages, control, alarm, warning and status words.
300-**	AF Settings	Parameter group for setting the Active Filter. Apart from par. 300-10, <i>Active Filter Nominal Voltage</i> , it is not recommended to change the settings of this parameter group
301-**	AF Readouts	Parameter group for the filter readouts.

Table 6.9 Overview of Parameter Groups for the Filter Part

A list of all parameters accessible from the filter LCP can be found in *6.4 Parameter Lists - Active Filter*. A more detailed description of the active filter parameters can be found in the VLT Active Filter AAF005 Manual, *MG90VXY*

6.2.1 Using the Low Harmonic Drive in NPN Mode

The default setting for *5-00 Digital I/O Mode* is PNP mode. If NPN mode is desired, it is necessary to change the wiring in the filter part of the Low Harmonic Drive. Before changing the setting in *5-00 Digital I/O Mode* to NPN mode, the wire connected to 24 V (control terminal 12 or 13) must be changed to terminal 20 (ground).

6.3 Parameter Lists - Frequency Converter

6.3.1 Main Menu Structure

Parameters for the frequency converter are grouped into various parameter groups for easy selection of the correct parameters for optimized operation of the frequency converter.

The vast majority of VLT HVAC Drive applications can be programmed using the Quick Menu button and selecting the parameters under Quick Setup and Function Setups. Descriptions and default settings of parameters may be found under .

- 0-** Operation/Display
- 1-** Load/Motor
- 2-** Brakes
- 3-** Reference/Ramps
- 4-** Limits/ Warnings
- 5-** Digital In/Out
- 6-** Analog In/Out
- 8-** Comm. and Options
- 9-** Profibus
- 10-** CAN Fieldbus
- 11-** LonWorks
- 12-** Ethernet IP / Modbus TCP / PROFINET
- 13-** Smart Logic Controller
- 14-** Special Functions
- 15-** FC Information
- 16-** Data Readouts
- 18-** Info & Readouts
- 20-** FC Closed Loop
- 21-** Ext. Closed Loop
- 22-** Application Functions
- 23-** Time Based Functions
- 24-** Application Functions 2
- 25-** Cascade Controller
- 26-** Analog I/O Option MCB 109

6.3.2 0-** Operation and Display

Par. No. #	Parameter description	Default value	4-set-up	Change during operation	Conversion index	Type
0-0* Basic Settings						
0-01	Language	[0] English	1 set-up	TRUE	-	Uint8
0-02	Motor Speed Unit	[1] Hz	2 set-ups	FALSE	-	Uint8
0-03	Regional Settings	[0] International	2 set-ups	FALSE	-	Uint8
0-04	Operating State at Power-up	[0] Resume	All set-ups	TRUE	-	Uint8
0-05	Local Mode Unit	[0] As Motor Speed Unit	2 set-ups	FALSE	-	Uint8
0-1* Set-up Operations						
0-10	Active Set-up	[1] Set-up 1	1 set-up	TRUE	-	Uint8
0-11	Programming Set-up	[9] Active Set-up	All set-ups	TRUE	-	Uint8
0-12	This Set-up Linked to	[0] Not linked	All set-ups	FALSE	-	Uint8
0-13	Readout: Linked Set-ups	0 N/A	All set-ups	FALSE	0	Uint16
0-14	Readout: Prog. Set-ups / Channel	0 N/A	All set-ups	TRUE	0	Int32
0-2* LCP Display						
0-20	Display Line 1.1 Small	1602	All set-ups	TRUE	-	Uint16
0-21	Display Line 1.2 Small	1614	All set-ups	TRUE	-	Uint16
0-22	Display Line 1.3 Small	1610	All set-ups	TRUE	-	Uint16
0-23	Display Line 2 Large	1613	All set-ups	TRUE	-	Uint16
0-24	Display Line 3 Large	1502	All set-ups	TRUE	-	Uint16
0-25	My Personal Menu	ExpressionLimit	1 set-up	TRUE	0	Uint16
0-3* LCP Custom Readout						
0-30	Custom Readout Unit	[1] %	All set-ups	TRUE	-	Uint8
0-31	Custom Readout Min Value	ExpressionLimit	All set-ups	TRUE	-2	Int32
0-32	Custom Readout Max Value	100.00 CustomReadoutUnit	All set-ups	TRUE	-2	Int32
0-37	Display Text 1	0 N/A	1 set-up	TRUE	0	VisStr[25]
0-38	Display Text 2	0 N/A	1 set-up	TRUE	0	VisStr[25]
0-39	Display Text 3	0 N/A	1 set-up	TRUE	0	VisStr[25]
0-4* LCP Keypad						
0-40	[Hand on] Key on LCP	[1] Enabled	All set-ups	TRUE	-	Uint8
0-41	[Off] Key on LCP	[1] Enabled	All set-ups	TRUE	-	Uint8
0-42	[Auto on] Key on LCP	[1] Enabled	All set-ups	TRUE	-	Uint8
0-43	[Reset] Key on LCP	[1] Enabled	All set-ups	TRUE	-	Uint8
0-44	[Off/Reset] Key on LCP	[1] Enabled	All set-ups	TRUE	-	Uint8
0-45	[Drive Bypass] Key on LCP	[1] Enabled	All set-ups	TRUE	-	Uint8
0-5* Copy/Save						
0-50	LCP Copy	[0] No copy	All set-ups	FALSE	-	Uint8
0-51	Set-up Copy	[0] No copy	All set-ups	FALSE	-	Uint8
0-6* Password						
0-60	Main Menu Password	100 N/A	1 set-up	TRUE	0	Int16
0-61	Access to Main Menu w/o Password	[0] Full access	1 set-up	TRUE	-	Uint8
0-65	Personal Menu Password	200 N/A	1 set-up	TRUE	0	Int16
0-66	Access to Personal Menu w/o Password	[0] Full access	1 set-up	TRUE	-	Uint8
0-7* Clock Settings						
0-70	Date and Time	ExpressionLimit	All set-ups	TRUE	0	TimeOfDay
0-71	Date Format	ExpressionLimit	1 set-up	TRUE	-	Uint8
0-72	Time Format	ExpressionLimit	1 set-up	TRUE	-	Uint8
0-74	DST/Summertime	[0] Off	1 set-up	TRUE	-	Uint8
0-76	DST/Summertime Start	ExpressionLimit	1 set-up	TRUE	0	TimeOfDay
0-77	DST/Summertime End	ExpressionLimit	1 set-up	TRUE	0	TimeOfDay
0-79	Clock Fault	ExpressionLimit	1 set-up	TRUE	-	Uint8

Par. No. #	Parameter description	Default value	4-set-up	Change during operation	Conversion index	Type
0-81	Working Days	ExpressionLimit	1 set-up	TRUE	-	UInt8
0-82	Additional Working Days	ExpressionLimit	1 set-up	TRUE	0	TimeOfDay
0-83	Additional Non-Working Days	ExpressionLimit	1 set-up	TRUE	0	TimeOfDay
0-89	Date and Time Readout	0 N/A	All set-ups	TRUE	0	VisStr[25]

Table 6.10

6.3.3 1-** Load / Motor

Par. No. #	Parameter description	Default value	4-set-up	Change during operation	Conversion index	Type
1-0* General Settings						
1-00	Configuration Mode	ExpressionLimit	All set-ups	TRUE	-	UInt8
1-03	Torque Characteristics	[3] Auto Energy Optim. VT	All set-ups	TRUE	-	UInt8
1-06	Clockwise Direction	[0] Normal	All set-ups	FALSE	-	UInt8
1-1* Motor Selection						
1-10	Motor Construction	[0] Asynchron	All set-ups	FALSE	-	UInt8
1-1* VVC+ PM						
1-14	Damping Gain	120 %	All set-ups	TRUE	0	Int16
1-15	Low Speed Filter Time Const.	ExpressionLimit	All set-ups	TRUE	-2	UInt16
1-16	High Speed Filter Time Const.	ExpressionLimit	All set-ups	TRUE	-2	UInt16
1-17	Voltage filter time const.	ExpressionLimit	All set-ups	TRUE	-3	UInt16
1-2* Motor Data						
1-20	Motor Power [kW]	ExpressionLimit	All set-ups	FALSE	1	UInt32
1-21	Motor Power [HP]	ExpressionLimit	All set-ups	FALSE	-2	UInt32
1-22	Motor Voltage	ExpressionLimit	All set-ups	FALSE	0	UInt16
1-23	Motor Frequency	ExpressionLimit	All set-ups	FALSE	0	UInt16
1-24	Motor Current	ExpressionLimit	All set-ups	FALSE	-2	UInt32
1-25	Motor Nominal Speed	ExpressionLimit	All set-ups	FALSE	67	UInt16
1-28	Motor Rotation Check	[0] Off	All set-ups	FALSE	-	UInt8
1-29	Automatic Motor Adaptation (AMA)	[0] Off	All set-ups	FALSE	-	UInt8
1-3* Adv. Motor Data						
1-30	Stator Resistance (Rs)	ExpressionLimit	All set-ups	FALSE	-4	UInt32
1-31	Rotor Resistance (Rr)	ExpressionLimit	All set-ups	FALSE	-4	UInt32
1-35	Main Reactance (Xh)	ExpressionLimit	All set-ups	FALSE	-4	UInt32
1-36	Iron Loss Resistance (Rfe)	ExpressionLimit	All set-ups	FALSE	-3	UInt32
1-37	d-axis Inductance (Ld)	ExpressionLimit	All set-ups	FALSE	-6	Int32
1-39	Motor Poles	ExpressionLimit	All set-ups	FALSE	0	UInt8
1-40	Back EMF at 1000 RPM	ExpressionLimit	All set-ups	FALSE	0	UInt16
1-5* Load Indep. Setting						
1-50	Motor Magnetisation at Zero Speed	100 %	All set-ups	TRUE	0	UInt16
1-51	Min Speed Normal Magnetising [RPM]	ExpressionLimit	All set-ups	TRUE	67	UInt16
1-52	Min Speed Normal Magnetising [Hz]	ExpressionLimit	All set-ups	TRUE	-1	UInt16
1-58	Flystart Test Pulses Current	30 %	All set-ups	FALSE	0	UInt16
1-59	Flystart Test Pulses Frequency	200 %	All set-ups	FALSE	0	UInt16
1-6* Load Depen. Setting						
1-60	Low Speed Load Compensation	100 %	All set-ups	TRUE	0	Int16
1-61	High Speed Load Compensation	100 %	All set-ups	TRUE	0	Int16
1-62	Slip Compensation	0 %	All set-ups	TRUE	0	Int16
1-63	Slip Compensation Time Constant	ExpressionLimit	All set-ups	TRUE	-2	UInt16

Par. No. #	Parameter description	Default value	4-set-up	Change during operation	Conversion index	Type
1-64	Resonance Dampening	100 %	All set-ups	TRUE	0	Uint16
1-65	Resonance Dampening Time Constant	5 ms	All set-ups	TRUE	-3	Uint8
1-66	Min. Current at Low Speed	ExpressionLimit	All set-ups	TRUE	0	Uint8
1-7* Start Adjustments						
1-70	PM startmode	Parking	All set-ups	TRUE	0	Uint8
1-71	Start Delay	0.0 s	All set-ups	TRUE	-1	Uint16
1-72	Start Function	ExpressionLimit	All set-ups	TRUE	-	Uint8
1-73	Flying Start	[0] Disabled	All set-ups	TRUE	-	Uint8
1-77	Compressor Start Max Speed [RPM]	ExpressionLimit	All set-ups	TRUE	67	Uint16
1-78	Compressor Start Max Speed [Hz]	ExpressionLimit	All set-ups	TRUE	-1	Uint16
1-79	Compressor Start Max Time to Trip	5.0 s	All set-ups	TRUE	-1	Uint8
1-8* Stop Adjustments						
1-80	Function at Stop	[0] Coast	All set-ups	TRUE	-	Uint8
1-81	Min Speed for Function at Stop [RPM]	ExpressionLimit	All set-ups	TRUE	67	Uint16
1-82	Min Speed for Function at Stop [Hz]	ExpressionLimit	All set-ups	TRUE	-1	Uint16
1-86	Trip Speed Low [RPM]	ExpressionLimit	All set-ups	TRUE	67	Uint16
1-87	Trip Speed Low [Hz]	ExpressionLimit	All set-ups	TRUE	-1	Uint16
1-9* Motor Temperature						
1-90	Motor Thermal Protection	[4] ETR trip 1	All set-ups	TRUE	-	Uint8
1-91	Motor External Fan	[0] No	All set-ups	TRUE	-	Uint16
1-93	Thermistor Source	[0] None	All set-ups	TRUE	-	Uint8

Table 6.11

6.3.4 2-** Brakes

Par. No. #	Parameter description	Default value	4-set-up	Change during operation	Conversion index	Type
2-0* DC-Brake						
2-00	DC Hold/Preheat Current	50 %	All set-ups	TRUE	0	Uint8
2-01	DC Brake Current	50 %	All set-ups	TRUE	0	Uint16
2-02	DC Braking Time	10.0 s	All set-ups	TRUE	-1	Uint16
2-03	DC Brake Cut In Speed [RPM]	ExpressionLimit	All set-ups	TRUE	67	Uint16
2-04	DC Brake Cut In Speed [Hz]	ExpressionLimit	All set-ups	TRUE	-1	Uint16
2-06	Parking Current	50%	All set-ups	TRUE	0	Uint16
2-07	Parking Time	3.0	All set-ups	TRUE	-1	Uint16
2-1* Brake Energy Funct.						
2-10	Brake Function	[0] Off	All set-ups	TRUE	-	Uint8
2-11	Brake Resistor (ohm)	ExpressionLimit	All set-ups	TRUE	-2	Uint32
2-12	Brake Power Limit (kW)	ExpressionLimit	All set-ups	TRUE	0	Uint32
2-13	Brake Power Monitoring	[0] Off	All set-ups	TRUE	-	Uint8
2-15	Brake Check	[0] Off	All set-ups	TRUE	-	Uint8
2-16	AC brake Max. Current	ExpressionLimit	All set-ups	TRUE	-1	Uint32
2-17	Over-voltage Control	[2] Enabled	All set-ups	TRUE	-	Uint8

Table 6.12

6.3.5 3-** Reference / Ramps

Par. No. #	Parameter description	Default value	4-set-up	Change during operation	Conversion index	Type
3-0* Reference Limits						
3-02	Minimum Reference	ExpressionLimit	All set-ups	TRUE	-3	Int32
3-03	Maximum Reference	ExpressionLimit	All set-ups	TRUE	-3	Int32
3-04	Reference Function	ExpressionLimit	All set-ups	TRUE	-	UInt8
3-1* References						
3-10	Preset Reference	0.00 %	All set-ups	TRUE	-2	Int16
3-11	Jog Speed [Hz]	ExpressionLimit	All set-ups	TRUE	-1	UInt16
3-13	Reference Site	[0] Linked to Hand / Auto	All set-ups	TRUE	-	UInt8
3-14	Preset Relative Reference	0.00 %	All set-ups	TRUE	-2	Int32
3-15	Reference 1 Source	[1] Analog input 53	All set-ups	TRUE	-	UInt8
3-16	Reference 2 Source	[20] Digital pot.meter	All set-ups	TRUE	-	UInt8
3-17	Reference 3 Source	[0] No function	All set-ups	TRUE	-	UInt8
3-19	Jog Speed [RPM]	ExpressionLimit	All set-ups	TRUE	67	UInt16
3-4* Ramp 1						
3-41	Ramp 1 Ramp Up Time	ExpressionLimit	All set-ups	TRUE	-2	UInt32
3-42	Ramp 1 Ramp Down Time	ExpressionLimit	All set-ups	TRUE	-2	UInt32
3-5* Ramp 2						
3-51	Ramp 2 Ramp Up Time	ExpressionLimit	All set-ups	TRUE	-2	UInt32
3-52	Ramp 2 Ramp Down Time	ExpressionLimit	All set-ups	TRUE	-2	UInt32
3-8* Other Ramps						
3-80	Jog Ramp Time	ExpressionLimit	All set-ups	TRUE	-2	UInt32
3-81	Quick Stop Ramp Time	ExpressionLimit	2 set-ups	TRUE	-2	UInt32
3-82	Starting Ramp Up Time	ExpressionLimit	2 set-ups	TRUE	-2	UInt32
3-9* Digital Pot.Meter						
3-90	Step Size	0.10 %	All set-ups	TRUE	-2	UInt16
3-91	Ramp Time	1.00 s	All set-ups	TRUE	-2	UInt32
3-92	Power Restore	[0] Off	All set-ups	TRUE	-	UInt8
3-93	Maximum Limit	100 %	All set-ups	TRUE	0	Int16
3-94	Minimum Limit	0 %	All set-ups	TRUE	0	Int16
3-95	Ramp Delay	ExpressionLimit	All set-ups	TRUE	-3	TimD

Table 6.13

6.3.6 4-** Limits / Warnings

Par. No. #	Parameter description	Default value	4-set-up	Change during operation	Conversion index	Type
4-1* Motor Limits						
4-10	Motor Speed Direction	[2] Both directions	All set-ups	FALSE	-	UInt8
4-11	Motor Speed Low Limit [RPM]	ExpressionLimit	All set-ups	TRUE	67	UInt16
4-12	Motor Speed Low Limit [Hz]	ExpressionLimit	All set-ups	TRUE	-1	UInt16
4-13	Motor Speed High Limit [RPM]	ExpressionLimit	All set-ups	TRUE	67	UInt16
4-14	Motor Speed High Limit [Hz]	ExpressionLimit	All set-ups	TRUE	-1	UInt16
4-16	Torque Limit Motor Mode	ExpressionLimit	All set-ups	TRUE	-1	UInt16
4-17	Torque Limit Generator Mode	100.0 %	All set-ups	TRUE	-1	UInt16
4-18	Current Limit	ExpressionLimit	All set-ups	TRUE	-1	UInt32
4-19	Max Output Frequency	ExpressionLimit	All set-ups	FALSE	-1	UInt16
4-5* Adj. Warnings						

Par. No. #	Parameter description	Default value	4-set-up	Change during operation	Conversion index	Type
4-50	Warning Current Low	0.00 A	All set-ups	TRUE	-2	Uint32
4-51	Warning Current High	Param. 1637	All set-ups	TRUE	-2	Uint32
4-52	Warning Speed Low	0 RPM	All set-ups	TRUE	67	Uint16
4-53	Warning Speed High	Param. 413	All set-ups	TRUE	67	Uint16
4-54	Warning Reference Low	-999999.999 N/A	All set-ups	TRUE	-3	Int32
4-55	Warning Reference High	999999.999 N/A	All set-ups	TRUE	-3	Int32
4-56	Warning Feedback Low	-999999.999 ProcessCtrlUnit	All set-ups	TRUE	-3	Int32
4-57	Warning Feedback High	999999.999 ProcessCtrlUnit	All set-ups	TRUE	-3	Int32
4-58	Missing Motor Phase Function	[2] Trip 1000 ms	All set-ups	TRUE	-	Uint8
4-6* Speed Bypass						
4-60	Bypass Speed From [RPM]	ExpressionLimit	All set-ups	TRUE	67	Uint16
4-61	Bypass Speed From [Hz]	ExpressionLimit	All set-ups	TRUE	-1	Uint16
4-62	Bypass Speed To [RPM]	ExpressionLimit	All set-ups	TRUE	67	Uint16
4-63	Bypass Speed To [Hz]	ExpressionLimit	All set-ups	TRUE	-1	Uint16
4-64	Semi-Auto Bypass Set-up	[0] Off	All set-ups	FALSE	-	Uint8

Table 6.14

6.3.7 5-** Digital In / Out

Par. No. #	Parameter description	Default value	4-set-up	Change during operation	Conversion index	Type
5-0* Digital I/O mode						
5-00	Digital I/O Mode	[0] PNP - Active at 24V	All set-ups	FALSE	-	Uint8
5-01	Terminal 27 Mode	[0] Input	All set-ups	TRUE	-	Uint8
5-02	Terminal 29 Mode	[0] Input	All set-ups	TRUE	-	Uint8
5-1* Digital Inputs						
5-10	Terminal 18 Digital Input	[8] Start	All set-ups	TRUE	-	Uint8
5-11	Terminal 19 Digital Input	[0] No operation	All set-ups	TRUE	-	Uint8
5-12	Terminal 27 Digital Input	ExpressionLimit	All set-ups	TRUE	-	Uint8
5-13	Terminal 29 Digital Input	[14] Jog	All set-ups	TRUE	-	Uint8
5-14	Terminal 32 Digital Input	[0] No operation	All set-ups	TRUE	-	Uint8
5-15	Terminal 33 Digital Input	[0] No operation	All set-ups	TRUE	-	Uint8
5-16	Terminal X30/2 Digital Input	[0] No operation	All set-ups	TRUE	-	Uint8
5-17	Terminal X30/3 Digital Input	[0] No operation	All set-ups	TRUE	-	Uint8
5-18	Terminal X30/4 Digital Input	[0] No operation	All set-ups	TRUE	-	Uint8
5-19	Terminal 37 Safe Stop	[1] Safe Stop Alarm	1 set-up	TRUE	-	Uint8
5-3* Digital Outputs						
5-30	Terminal 27 Digital Output	[0] No operation	All set-ups	TRUE	-	Uint8
5-31	Terminal 29 Digital Output	[0] No operation	All set-ups	TRUE	-	Uint8
5-32	Term X30/6 Digi Out (MCB 101)	[0] No operation	All set-ups	TRUE	-	Uint8
5-33	Term X30/7 Digi Out (MCB 101)	[0] No operation	All set-ups	TRUE	-	Uint8
5-4* Relays						
5-40	Function Relay	ExpressionLimit	All set-ups	TRUE	-	Uint8
5-41	On Delay, Relay	0.01 s	All set-ups	TRUE	-2	Uint16
5-42	Off Delay, Relay	0.01 s	All set-ups	TRUE	-2	Uint16
5-5* Pulse Input						
5-50	Term. 29 Low Frequency	100 Hz	All set-ups	TRUE	0	Uint32
5-51	Term. 29 High Frequency	100 Hz	All set-ups	TRUE	0	Uint32
5-52	Term. 29 Low Ref./Feedb. Value	0.000 N/A	All set-ups	TRUE	-3	Int32
5-53	Term. 29 High Ref./Feedb. Value	100.000 N/A	All set-ups	TRUE	-3	Int32

Par. No. #	Parameter description	Default value	4-set-up	Change during operation	Conversion index	Type
5-54	Pulse Filter Time Constant #29	100 ms	All set-ups	FALSE	-3	Uint16
5-55	Term. 33 Low Frequency	100 Hz	All set-ups	TRUE	0	Uint32
5-56	Term. 33 High Frequency	100 Hz	All set-ups	TRUE	0	Uint32
5-57	Term. 33 Low Ref./Feedb. Value	0.000 N/A	All set-ups	TRUE	-3	Int32
5-58	Term. 33 High Ref./Feedb. Value	100.000 N/A	All set-ups	TRUE	-3	Int32
5-59	Pulse Filter Time Constant #33	100 ms	All set-ups	FALSE	-3	Uint16
5-6* Pulse Output						
5-60	Terminal 27 Pulse Output Variable	[0] No operation	All set-ups	TRUE	-	Uint8
5-62	Pulse Output Max Freq #27	5000 Hz	All set-ups	TRUE	0	Uint32
5-63	Terminal 29 Pulse Output Variable	[0] No operation	All set-ups	TRUE	-	Uint8
5-65	Pulse Output Max Freq #29	5000 Hz	All set-ups	TRUE	0	Uint32
5-66	Terminal X30/6 Pulse Output Variable	[0] No operation	All set-ups	TRUE	-	Uint8
5-68	Pulse Output Max Freq #X30/6	5000 Hz	All set-ups	TRUE	0	Uint32
5-9* Bus Controlled						
5-90	Digital & Relay Bus Control	0 N/A	All set-ups	TRUE	0	Uint32
5-93	Pulse Out #27 Bus Control	0.00 %	All set-ups	TRUE	-2	N2
5-94	Pulse Out #27 Timeout Preset	0.00 %	1 set-up	TRUE	-2	Uint16
5-95	Pulse Out #29 Bus Control	0.00 %	All set-ups	TRUE	-2	N2
5-96	Pulse Out #29 Timeout Preset	0.00 %	1 set-up	TRUE	-2	Uint16
5-97	Pulse Out #X30/6 Bus Control	0.00 %	All set-ups	TRUE	-2	N2
5-98	Pulse Out #X30/6 Timeout Preset	0.00 %	1 set-up	TRUE	-2	Uint16

Table 6.15

6.3.8 6-** Analog In / Out

Par. No. #	Parameter description	Default value	4-set-up	Change during operation	Conversion index	Type
6-0* Analog I/O Mode						
6-00	Live Zero Timeout Time	10 s	All set-ups	TRUE	0	Uint8
6-01	Live Zero Timeout Function	[0] Off	All set-ups	TRUE	-	Uint8
6-02	Fire Mode Live Zero Timeout Function	[0] Off	All set-ups	TRUE	-	Uint8
6-1* Analog Input 53						
6-10	Terminal 53 Low Voltage	0.07 V	All set-ups	TRUE	-2	Int16
6-11	Terminal 53 High Voltage	10.00 V	All set-ups	TRUE	-2	Int16
6-12	Terminal 53 Low Current	4.00 mA	All set-ups	TRUE	-5	Int16
6-13	Terminal 53 High Current	20.00 mA	All set-ups	TRUE	-5	Int16
6-14	Terminal 53 Low Ref./Feedb. Value	0.000 N/A	All set-ups	TRUE	-3	Int32
6-15	Terminal 53 High Ref./Feedb. Value	ExpressionLimit	All set-ups	TRUE	-3	Int32
6-16	Terminal 53 Filter Time Constant	0.001 s	All set-ups	TRUE	-3	Uint16
6-17	Terminal 53 Live Zero	[1] Enabled	All set-ups	TRUE	-	Uint8
6-2* Analog Input 54						
6-20	Terminal 54 Low Voltage	0.07 V	All set-ups	TRUE	-2	Int16
6-21	Terminal 54 High Voltage	10.00 V	All set-ups	TRUE	-2	Int16
6-22	Terminal 54 Low Current	4.00 mA	All set-ups	TRUE	-5	Int16
6-23	Terminal 54 High Current	20.00 mA	All set-ups	TRUE	-5	Int16
6-24	Terminal 54 Low Ref./Feedb. Value	0.000 N/A	All set-ups	TRUE	-3	Int32
6-25	Terminal 54 High Ref./Feedb. Value	100.000 N/A	All set-ups	TRUE	-3	Int32
6-26	Terminal 54 Filter Time Constant	0.001 s	All set-ups	TRUE	-3	Uint16
6-27	Terminal 54 Live Zero	[1] Enabled	All set-ups	TRUE	-	Uint8
6-3* Analog Input X30/11						

Par. No. #	Parameter description	Default value	4-set-up	Change during operation	Conversion index	Type
6-30	Terminal X30/11 Low Voltage	0.07 V	All set-ups	TRUE	-2	Int16
6-31	Terminal X30/11 High Voltage	10.00 V	All set-ups	TRUE	-2	Int16
6-34	Term. X30/11 Low Ref./Feedb. Value	0.000 N/A	All set-ups	TRUE	-3	Int32
6-35	Term. X30/11 High Ref./Feedb. Value	100.000 N/A	All set-ups	TRUE	-3	Int32
6-36	Term. X30/11 Filter Time Constant	0.001 s	All set-ups	TRUE	-3	Uint16
6-37	Term. X30/11 Live Zero	[1] Enabled	All set-ups	TRUE	-	Uint8
6-4* Analog Input X30/12						
6-40	Terminal X30/12 Low Voltage	0.07 V	All set-ups	TRUE	-2	Int16
6-41	Terminal X30/12 High Voltage	10.00 V	All set-ups	TRUE	-2	Int16
6-44	Term. X30/12 Low Ref./Feedb. Value	0.000 N/A	All set-ups	TRUE	-3	Int32
6-45	Term. X30/12 High Ref./Feedb. Value	100.000 N/A	All set-ups	TRUE	-3	Int32
6-46	Term. X30/12 Filter Time Constant	0.001 s	All set-ups	TRUE	-3	Uint16
6-47	Term. X30/12 Live Zero	[1] Enabled	All set-ups	TRUE	-	Uint8
6-5* Analog Output 42						
6-50	Terminal 42 Output	ExpressionLimit	All set-ups	TRUE	-	Uint8
6-51	Terminal 42 Output Min Scale	0.00 %	All set-ups	TRUE	-2	Int16
6-52	Terminal 42 Output Max Scale	100.00 %	All set-ups	TRUE	-2	Int16
6-53	Terminal 42 Output Bus Control	0.00 %	All set-ups	TRUE	-2	N2
6-54	Terminal 42 Output Timeout Preset	0.00 %	1 set-up	TRUE	-2	Uint16
6-55	Analog Output Filter	[0] Off	1 set-up	TRUE	-	Uint8
6-6* Analog Output X30/8						
6-60	Terminal X30/8 Output	[0] No operation	All set-ups	TRUE	-	Uint8
6-61	Terminal X30/8 Min. Scale	0.00 %	All set-ups	TRUE	-2	Int16
6-62	Terminal X30/8 Max. Scale	100.00 %	All set-ups	TRUE	-2	Int16
6-63	Terminal X30/8 Output Bus Control	0.00 %	All set-ups	TRUE	-2	N2
6-64	Terminal X30/8 Output Timeout Preset	0.00 %	1 set-up	TRUE	-2	Uint16

Table 6.16

6.3.9 8-** Communication and Options

Par. No. #	Parameter description	Default value	4-set-up	Change during operation	Conversion index	Type
8-0* General Settings						
8-01	Control Site	null	All set-ups	TRUE	-	Uint8
8-02	Control Source	null	All set-ups	TRUE	-	Uint8
8-03	Control Timeout Time	SR	1 set-up	TRUE	-1	Uint32
8-04	Control Timeout Function	[0] Off	1 set-up	TRUE	-	Uint8
8-05	End-of-Timeout Function	[1] Resume set-up	1 set-up	TRUE	-	Uint8
8-06	Reset Control Timeout	[0] Do not reset	All set-ups	TRUE	-	Uint8
8-07	Diagnosis Trigger	[0] Disable	2 set-ups	TRUE	-	Uint8
8-1* Control Settings						
8-10	Control Profile	[0] FC profile	All set-ups	FALSE	-	Uint8
8-13	Configurable Status Word STW	[1] Profile Default	All set-ups	TRUE	-	Uint8
8-3* FC Port Settings						
8-30	Protocol	null	1 set-up	TRUE	-	Uint8
8-31	Address	SR	1 set-up	TRUE	0	Uint8
8-32	Baud Rate	null	1 set-up	TRUE	-	Uint8
8-33	Parity / Stop Bits	null	1 set-up	TRUE	-	Uint8
8-34	Estimated cycle time	0 ms	2 set-ups	TRUE	-3	Uint32

Par. No. #	Parameter description	Default value	4-set-up	Change during operation	Conversion index	Type
8-35	Minimum Response Delay	SR	1 set-up	TRUE	-3	Uint16
8-36	Maximum Response Delay	SR	1 set-up	TRUE	-3	Uint16
8-37	Maximum Inter-Char Delay	SR	1 set-up	TRUE	-5	Uint16
8-4* FC MC protocol set						
8-40	Telegram Selection	[1] Standard telegram 1	2 set-ups	TRUE	-	Uint8
8-42	PCD write configuration	SR	All set-ups	TRUE	-	Uint16
8-43	PCD read configuration	SR	All set-ups	TRUE	-	Uint16
8-5* Digital/Bus						
8-50	Coasting Select	[3] Logic OR	All set-ups	TRUE	-	Uint8
8-52	DC Brake Select	[3] Logic OR	All set-ups	TRUE	-	Uint8
8-53	Start Select	[3] Logic OR	All set-ups	TRUE	-	Uint8
8-54	Reversing Select	null	All set-ups	TRUE	-	Uint8
8-55	Set-up Select	[3] Logic OR	All set-ups	TRUE	-	Uint8
8-56	Preset Reference Select	[3] Logic OR	All set-ups	TRUE	-	Uint8
8-7* BACnet						
8-70	BACnet Device Instance	1 N/A	1 set-up	TRUE	0	Uint32
8-72	MS/TP Max Masters	127 N/A	1 set-up	TRUE	0	Uint8
8-73	MS/TP Max Info Frames	1 N/A	1 set-up	TRUE	0	Uint16
8-74	"I-Am" Service	[0] Send at power-up	1 set-up	TRUE	-	Uint8
8-75	Initialisation Password	SR	1 set-up	TRUE	0	VisStr[20]
8-8* FC Port Diagnostics						
8-80	Bus Message Count	0 N/A	All set-ups	TRUE	0	Uint32
8-81	Bus Error Count	0 N/A	All set-ups	TRUE	0	Uint32
8-82	Slave Messages Rcvd	0 N/A	All set-ups	TRUE	0	Uint32
8-83	Slave Error Count	0 N/A	All set-ups	TRUE	0	Uint32
8-84	Slave Messages Sent	0 N/A	All set-ups	TRUE	0	Uint32
8-85	Slave Timeout Errors	0 N/A	All set-ups	TRUE	0	Uint32
8-89	Diagnostics Count	0 N/A	1 set-up	TRUE	0	Int32
8-9* Bus Jog / Feedback						
8-90	Bus Jog 1 Speed	100 RPM	All set-ups	TRUE	67	Uint16
8-91	Bus Jog 2 Speed	200 RPM	All set-ups	TRUE	67	Uint16
8-94	Bus Feedback 1	0 N/A	1 set-up	TRUE	0	N2
8-95	Bus Feedback 2	0 N/A	1 set-up	TRUE	0	N2
8-96	Bus Feedback 3	0 N/A	1 set-up	TRUE	0	N2

Table 6.17

6.3.10 9-** Profibus

Par. No. #	Parameter description	Default value	4-set-up	Change during operation	Conversion index	Type
9-00	Setpoint	0 N/A	All set-ups	TRUE	0	Uint16
9-07	Actual Value	0 N/A	All set-ups	FALSE	0	Uint16
9-15	PCD Write Configuration	ExpressionLimit	2 set-ups	TRUE	-	Uint16
9-16	PCD Read Configuration	ExpressionLimit	2 set-ups	TRUE	-	Uint16
9-18	Node Address	126 N/A	1 set-up	TRUE	0	Uint8
9-22	Telegram Selection	[108] PPO 8	1 set-up	TRUE	-	Uint8
9-23	Parameters for Signals	0	All set-ups	TRUE	-	Uint16
9-27	Parameter Edit	[1] Enabled	2 set-ups	FALSE	-	Uint16
9-28	Process Control	[1] Enable cyclic master	2 set-ups	FALSE	-	Uint8

Par. No. #	Parameter description	Default value	4-set-up	Change during operation	Conversion index	Type
9-44	Fault Message Counter	0 N/A	All set-ups	TRUE	0	Uint16
9-45	Fault Code	0 N/A	All set-ups	TRUE	0	Uint16
9-47	Fault Number	0 N/A	All set-ups	TRUE	0	Uint16
9-52	Fault Situation Counter	0 N/A	All set-ups	TRUE	0	Uint16
9-53	Profibus Warning Word	0 N/A	All set-ups	TRUE	0	V2
9-63	Actual Baud Rate	[255] No baudrate found	All set-ups	TRUE	-	Uint8
9-64	Device Identification	0 N/A	All set-ups	TRUE	0	Uint16
9-65	Profile Number	0 N/A	All set-ups	TRUE	0	OctStr[2]
9-67	Control Word 1	0 N/A	All set-ups	TRUE	0	V2
9-68	Status Word 1	0 N/A	All set-ups	TRUE	0	V2
9-71	Profibus Save Data Values	[0] Off	All set-ups	TRUE	-	Uint8
9-72	ProfibusDriveReset	[0] No action	1 set-up	FALSE	-	Uint8
9-80	Defined Parameters (1)	0 N/A	All set-ups	FALSE	0	Uint16
9-81	Defined Parameters (2)	0 N/A	All set-ups	FALSE	0	Uint16
9-82	Defined Parameters (3)	0 N/A	All set-ups	FALSE	0	Uint16
9-83	Defined Parameters (4)	0 N/A	All set-ups	FALSE	0	Uint16
9-84	Defined Parameters (5)	0 N/A	All set-ups	FALSE	0	Uint16
9-90	Changed Parameters (1)	0 N/A	All set-ups	FALSE	0	Uint16
9-91	Changed Parameters (2)	0 N/A	All set-ups	FALSE	0	Uint16
9-92	Changed Parameters (3)	0 N/A	All set-ups	FALSE	0	Uint16
9-93	Changed Parameters (4)	0 N/A	All set-ups	FALSE	0	Uint16
9-94	Changed Parameters (5)	0 N/A	All set-ups	FALSE	0	Uint16

Table 6.18

6.3.11 10-** CAN Fieldbus

Par. No. #	Parameter description	Default value	4-set-up	Change during operation	Conversion index	Type
10-0* Common Settings						
10-00	CAN Protocol	ExpressionLimit	2 set-ups	FALSE	-	Uint8
10-01	Baud Rate Select	ExpressionLimit	2 set-ups	TRUE	-	Uint8
10-02	MAC ID	ExpressionLimit	2 set-ups	TRUE	0	Uint8
10-05	Readout Transmit Error Counter	0 N/A	All set-ups	TRUE	0	Uint8
10-06	Readout Receive Error Counter	0 N/A	All set-ups	TRUE	0	Uint8
10-07	Readout Bus Off Counter	0 N/A	All set-ups	TRUE	0	Uint8
10-1* DeviceNet						
10-10	Process Data Type Selection	ExpressionLimit	All set-ups	TRUE	-	Uint8
10-11	Process Data Config Write	ExpressionLimit	2 set-ups	TRUE	-	Uint16
10-12	Process Data Config Read	ExpressionLimit	2 set-ups	TRUE	-	Uint16
10-13	Warning Parameter	0 N/A	All set-ups	TRUE	0	Uint16
10-14	Net Reference	[0] Off	2 set-ups	TRUE	-	Uint8
10-15	Net Control	[0] Off	2 set-ups	TRUE	-	Uint8
10-2* COS Filters						
10-20	COS Filter 1	0 N/A	All set-ups	FALSE	0	Uint16
10-21	COS Filter 2	0 N/A	All set-ups	FALSE	0	Uint16
10-22	COS Filter 3	0 N/A	All set-ups	FALSE	0	Uint16
10-23	COS Filter 4	0 N/A	All set-ups	FALSE	0	Uint16
10-3* Parameter Access						
10-30	Array Index	0 N/A	2 set-ups	TRUE	0	Uint8

Par. No. #	Parameter description	Default value	4-set-up	Change during operation	Conversion index	Type
10-31	Store Data Values	[0] Off	All set-ups	TRUE	-	Uint8
10-32	Devicenet Revision	0 N/A	All set-ups	TRUE	0	Uint16
10-33	Store Always	[0] Off	1 set-up	TRUE	-	Uint8
10-34	DeviceNet Product Code	120 N/A	1 set-up	TRUE	0	Uint16
10-39	Devicenet F Parameters	0 N/A	All set-ups	TRUE	0	Uint32

Table 6.19

6.3.12 11-** LonWorks

Par. No. #	Parameter description	Default value	4-set-up	Change during operation	Conversion index	Type
11-0* LonWorks ID						
11-00	Neuron ID	0 N/A	All set-ups	TRUE	0	OctStr[6]
11-1* LON Functions						
11-10	Drive Profile	[0] VSD profile	All set-ups	TRUE	-	UInt8
11-15	LON Warning Word	0 N/A	All set-ups	TRUE	0	UInt16
11-17	XIF Revision	0 N/A	All set-ups	TRUE	0	VisStr[5]
11-18	LonWorks Revision	0 N/A	All set-ups	TRUE	0	VisStr[5]
11-2* LON Param. Access						
11-21	Store Data Values	[0] Off	All set-ups	TRUE	-	UInt8

Table 6.20

6.3.13 13-** Smart Logic Controller

Par. No. #	Parameter description	Default value	4-set-up	Change during operation	Conversion index	Type
13-0* SLC Settings						
13-00	SL Controller Mode	ExpressionLimit	2 set-ups	TRUE	-	UInt8
13-01	Start Event	ExpressionLimit	2 set-ups	TRUE	-	UInt8
13-02	Stop Event	ExpressionLimit	2 set-ups	TRUE	-	UInt8
13-03	Reset SLC	[0] Do not reset SLC	All set-ups	TRUE	-	UInt8
13-1* Comparators						
13-10	Comparator Operand	ExpressionLimit	2 set-ups	TRUE	-	UInt8
13-11	Comparator Operator	ExpressionLimit	2 set-ups	TRUE	-	UInt8
13-12	Comparator Value	ExpressionLimit	2 set-ups	TRUE	-3	Int32
13-2* Timers						
13-20	SL Controller Timer	ExpressionLimit	1 set-up	TRUE	-3	TimD
13-4* Logic Rules						
13-40	Logic Rule Boolean 1	ExpressionLimit	2 set-ups	TRUE	-	UInt8
13-41	Logic Rule Operator 1	ExpressionLimit	2 set-ups	TRUE	-	UInt8
13-42	Logic Rule Boolean 2	ExpressionLimit	2 set-ups	TRUE	-	UInt8
13-43	Logic Rule Operator 2	ExpressionLimit	2 set-ups	TRUE	-	UInt8
13-44	Logic Rule Boolean 3	ExpressionLimit	2 set-ups	TRUE	-	UInt8
13-5* States						
13-51	SL Controller Event	ExpressionLimit	2 set-ups	TRUE	-	UInt8
13-52	SL Controller Action	ExpressionLimit	2 set-ups	TRUE	-	UInt8

Table 6.21

6.3.14 14-** Special Functions

Par. No. #	Parameter description	Default value	4-set-up	Change during operation	Conversion index	Type
14-0* Inverter Switching						
14-00	Switching Pattern	ExpressionLimit	All set-ups	TRUE	-	UInt8
14-01	Switching Frequency	ExpressionLimit	All set-ups	TRUE	-	UInt8
14-03	Overmodulation	[1] On	All set-ups	FALSE	-	UInt8

Par. No. #	Parameter description	Default value	4-set-up	Change during operation	Conversion index	Type
14-04	PWM Random	[0] Off	All set-ups	TRUE	-	Uint8
14-1* Mains On/Off						
14-10	Mains Failure	[0] No function	All set-ups	FALSE	-	Uint8
14-11	Mains Voltage at Mains Fault	ExpressionLimit	All set-ups	TRUE	0	Uint16
14-12	Function at Mains Imbalance	[0] Trip	All set-ups	TRUE	-	Uint8
14-2* Reset Functions						
14-20	Reset Mode	ExpressionLimit	All set-ups	TRUE	-	Uint8
14-21	Automatic Restart Time	10 s	All set-ups	TRUE	0	Uint16
14-22	Operation Mode	[0] Normal operation	All set-ups	TRUE	-	Uint8
14-23	Typecode Setting	ExpressionLimit	2 set-ups	FALSE	-	Uint8
14-25	Trip Delay at Torque Limit	60 s	All set-ups	TRUE	0	Uint8
14-26	Trip Delay at Inverter Fault	ExpressionLimit	All set-ups	TRUE	0	Uint8
14-28	Production Settings	[0] No action	All set-ups	TRUE	-	Uint8
14-29	Service Code	0 N/A	All set-ups	TRUE	0	Int32
14-3* Current Limit Ctrl.						
14-30	Current Lim Ctrl, Proportional Gain	100 %	All set-ups	FALSE	0	Uint16
14-31	Current Lim Ctrl, Integration Time	0.020 s	All set-ups	FALSE	-3	Uint16
14-32	Current Lim Ctrl, Filter Time	26.0 ms	All set-ups	TRUE	-4	Uint16
14-4* Energy Optimising						
14-40	VT Level	66 %	All set-ups	FALSE	0	Uint8
14-41	AEO Minimum Magnetisation	ExpressionLimit	All set-ups	TRUE	0	Uint8
14-42	Minimum AEO Frequency	10 Hz	All set-ups	TRUE	0	Uint8
14-43	Motor Cosphi	ExpressionLimit	All set-ups	TRUE	-2	Uint16
14-5* Environment						
14-50	RFI Filter	[1] On	1 set-up	FALSE	-	Uint8
14-51	DC Link Compensation	[1] On	1 set-up	TRUE	-	Uint8
14-52	Fan Control	[0] Auto	All set-ups	TRUE	-	Uint8
14-53	Fan Monitor	[1] Warning	All set-ups	TRUE	-	Uint8
14-55	Output Filter	[0] No Filter	1 set-up	FALSE	-	Uint8
14-59	Actual Number of Inverter Units	ExpressionLimit	1 set-up	FALSE	0	Uint8
14-6* Auto Derate						
14-60	Function at Over Temperature	[0] Trip	All set-ups	TRUE	-	Uint8
14-61	Function at Inverter Overload	[0] Trip	All set-ups	TRUE	-	Uint8
14-62	Inv. Overload Derate Current	95 %	All set-ups	TRUE	0	Uint16

Table 6.22

6.3.15 15-** Drive Information

6

Par. No. #	Parameter description	Default value	4-set-up	Change during operation	Conversion index	Type
15-0* Operating Data						
15-00	Operating Hours	0 h	All set-ups	FALSE	74	Uint32
15-01	Running Hours	0 h	All set-ups	FALSE	74	Uint32
15-02	kWh Counter	0 kWh	All set-ups	FALSE	75	Uint32
15-03	Power Up's	0 N/A	All set-ups	FALSE	0	Uint32
15-04	Over Temp's	0 N/A	All set-ups	FALSE	0	Uint16
15-05	Over Volt's	0 N/A	All set-ups	FALSE	0	Uint16
15-06	Reset kWh Counter	[0] Do not reset	All set-ups	TRUE	-	Uint8
15-07	Reset Running Hours Counter	[0] Do not reset	All set-ups	TRUE	-	Uint8
15-08	Number of Starts	0 N/A	All set-ups	FALSE	0	Uint32
15-1* Data Log Settings						
15-10	Logging Source	0	2 set-ups	TRUE	-	Uint16
15-11	Logging Interval	ExpressionLimit	2 set-ups	TRUE	-3	TimD
15-12	Trigger Event	[0] False	1 set-up	TRUE	-	Uint8
15-13	Logging Mode	[0] Log always	2 set-ups	TRUE	-	Uint8
15-14	Samples Before Trigger	50 N/A	2 set-ups	TRUE	0	Uint8
15-2* Historic Log						
15-20	Historic Log: Event	0 N/A	All set-ups	FALSE	0	Uint8
15-21	Historic Log: Value	0 N/A	All set-ups	FALSE	0	Uint32
15-22	Historic Log: Time	0 ms	All set-ups	FALSE	-3	Uint32
15-23	Historic Log: Date and Time	ExpressionLimit	All set-ups	FALSE	0	TimeOfDay
15-3* Alarm Log						
15-30	Alarm Log: Error Code	0 N/A	All set-ups	FALSE	0	Uint8
15-31	Alarm Log: Value	0 N/A	All set-ups	FALSE	0	Int16
15-32	Alarm Log: Time	0 s	All set-ups	FALSE	0	Uint32
15-33	Alarm Log: Date and Time	ExpressionLimit	All set-ups	FALSE	0	TimeOfDay
15-4* Drive Identification						
15-40	FC Type	0 N/A	All set-ups	FALSE	0	VisStr[6]
15-41	Power Section	0 N/A	All set-ups	FALSE	0	VisStr[20]
15-42	Voltage	0 N/A	All set-ups	FALSE	0	VisStr[20]
15-43	Software Version	0 N/A	All set-ups	FALSE	0	VisStr[5]
15-44	Ordered Typecode String	0 N/A	All set-ups	FALSE	0	VisStr[40]
15-45	Actual Typecode String	0 N/A	All set-ups	FALSE	0	VisStr[40]
15-46	Frequency Converter Ordering No	0 N/A	All set-ups	FALSE	0	VisStr[8]
15-47	Power Card Ordering No	0 N/A	All set-ups	FALSE	0	VisStr[8]
15-48	LCP Id No	0 N/A	All set-ups	FALSE	0	VisStr[20]
15-49	SW ID Control Card	0 N/A	All set-ups	FALSE	0	VisStr[20]
15-50	SW ID Power Card	0 N/A	All set-ups	FALSE	0	VisStr[20]
15-51	Frequency Converter Serial Number	0 N/A	All set-ups	FALSE	0	VisStr[10]
15-53	Power Card Serial Number	0 N/A	All set-ups	FALSE	0	VisStr[19]
15-55	Vendor URL	0 N/A	All set-ups	FALSE	0	VisStr[40]
15-56	Vendor Name	0 N/A	All set-ups	FALSE	0	VisStr[40]
15-6* Option Ident						
15-60	Option Mounted	0 N/A	All set-ups	FALSE	0	VisStr[30]
15-61	Option SW Version	0 N/A	All set-ups	FALSE	0	VisStr[20]
15-62	Option Ordering No	0 N/A	All set-ups	FALSE	0	VisStr[8]
15-63	Option Serial No	0 N/A	All set-ups	FALSE	0	VisStr[18]
15-70	Option in Slot A	0 N/A	All set-ups	FALSE	0	VisStr[30]
15-71	Slot A Option SW Version	0 N/A	All set-ups	FALSE	0	VisStr[20]

Par. No. #	Parameter description	Default value	4-set-up	Change during operation	Conversion index	Type
15-72	Option in Slot B	0 N/A	All set-ups	FALSE	0	VisStr[30]
15-73	Slot B Option SW Version	0 N/A	All set-ups	FALSE	0	VisStr[20]
15-74	Option in Slot C0	0 N/A	All set-ups	FALSE	0	VisStr[30]
15-75	Slot C0 Option SW Version	0 N/A	All set-ups	FALSE	0	VisStr[20]
15-76	Option in Slot C1	0 N/A	All set-ups	FALSE	0	VisStr[30]
15-77	Slot C1 Option SW Version	0 N/A	All set-ups	FALSE	0	VisStr[20]
15-9* Parameter Info						
15-92	Defined Parameters	0 N/A	All set-ups	FALSE	0	Uint16
15-93	Modified Parameters	0 N/A	All set-ups	FALSE	0	Uint16
15-98	Drive Identification	0 N/A	All set-ups	FALSE	0	VisStr[40]
15-99	Parameter Metadata	0 N/A	All set-ups	FALSE	0	Uint16

Table 6.23

6.3.16 16-** Data Readouts

Par. No. #	Parameter description	Default value	4-set-up	Change during operation	Conversion index	Type
16-0* General Status						
16-00	Control Word	0 N/A	All set-ups	FALSE	0	V2
16-01	Reference [Unit]	0.000 ReferenceFeedbackUnit	All set-ups	FALSE	-3	Int32
16-02	Reference [%]	0.0 %	All set-ups	FALSE	-1	Int16
16-03	Status Word	0 N/A	All set-ups	FALSE	0	V2
16-05	Main Actual Value [%]	0.00 %	All set-ups	FALSE	-2	N2
16-09	Custom Readout	0.00 CustomReadoutUnit	All set-ups	FALSE	-2	Int32
16-1* Motor Status						
16-10	Power [kW]	0.00 kW	All set-ups	FALSE	1	Int32
16-11	Power [hp]	0.00 hp	All set-ups	FALSE	-2	Int32
16-12	Motor Voltage	0.0 V	All set-ups	FALSE	-1	Uint16
16-13	Frequency	0.0 Hz	All set-ups	FALSE	-1	Uint16
16-14	Motor Current	0.00 A	All set-ups	FALSE	-2	Int32
16-15	Frequency [%]	0.00 %	All set-ups	FALSE	-2	N2
16-16	Torque [Nm]	0.0 Nm	All set-ups	FALSE	-1	Int32
16-17	Speed [RPM]	0 RPM	All set-ups	FALSE	67	Int32
16-18	Motor Thermal	0 %	All set-ups	FALSE	0	Uint8
16-22	Torque [%]	0 %	All set-ups	FALSE	0	Int16
16-26	Power Filtered [kW]	0.000 kW	All set-ups	FALSE	0	Int32
16-27	Power Filtered [hp]	0.000 hp	All set-ups	FALSE	-3	Int32
16-3* Drive Status						
16-30	DC Link Voltage	0 V	All set-ups	FALSE	0	Uint16
16-32	Brake Energy /s	0.000 kW	All set-ups	FALSE	0	Uint32
16-33	Brake Energy /2 min	0.000 kW	All set-ups	FALSE	0	Uint32
16-34	Heatsink Temp.	0 °C	All set-ups	FALSE	100	Uint8
16-35	Inverter Thermal	0 %	All set-ups	FALSE	0	Uint8
16-36	Inv. Nom. Current	ExpressionLimit	All set-ups	FALSE	-2	Uint32
16-37	Inv. Max. Current	ExpressionLimit	All set-ups	FALSE	-2	Uint32
16-38	SL Controller State	0 N/A	All set-ups	FALSE	0	Uint8
16-39	Control Card Temp.	0 °C	All set-ups	FALSE	100	Uint8
16-40	Logging Buffer Full	[0] No	All set-ups	TRUE	-	Uint8
16-43	Timed Actions Status	[0] Timed Actions Auto	All set-ups	TRUE	-	Uint8

Par. No. #	Parameter description	Default value	4-set-up	Change during operation	Conversion index	Type
16-49	Current Fault Source	0 N/A	All set-ups	TRUE	0	Uint8
16-5* Ref. & Feedb.						
16-50	External Reference	0.0 N/A	All set-ups	FALSE	-1	Int16
16-52	Feedback [Unit]	0.000 ProcessCtrlUnit	All set-ups	FALSE	-3	Int32
16-53	Digi Pot Reference	0.00 N/A	All set-ups	FALSE	-2	Int16
16-54	Feedback 1 [Unit]	0.000 ProcessCtrlUnit	All set-ups	FALSE	-3	Int32
16-55	Feedback 2 [Unit]	0.000 ProcessCtrlUnit	All set-ups	FALSE	-3	Int32
16-56	Feedback 3 [Unit]	0.000 ProcessCtrlUnit	All set-ups	FALSE	-3	Int32
16-58	PID Output [%]	0.0 %	All set-ups	TRUE	-1	Int16
16-6* Inputs & Outputs						
16-60	Digital Input	0 N/A	All set-ups	FALSE	0	Uint16
16-61	Terminal 53 Switch Setting	[0] Current	All set-ups	FALSE	-	Uint8
16-62	Analog Input 53	0.000 N/A	All set-ups	FALSE	-3	Int32
16-63	Terminal 54 Switch Setting	[0] Current	All set-ups	FALSE	-	Uint8
16-64	Analog Input 54	0.000 N/A	All set-ups	FALSE	-3	Int32
16-65	Analog Output 42 [mA]	0.000 N/A	All set-ups	FALSE	-3	Int16
16-66	Digital Output [bin]	0 N/A	All set-ups	FALSE	0	Int16
16-67	Pulse Input #29 [Hz]	0 N/A	All set-ups	FALSE	0	Int32
16-68	Pulse Input #33 [Hz]	0 N/A	All set-ups	FALSE	0	Int32
16-69	Pulse Output #27 [Hz]	0 N/A	All set-ups	FALSE	0	Int32
16-70	Pulse Output #29 [Hz]	0 N/A	All set-ups	FALSE	0	Int32
16-71	Relay Output [bin]	0 N/A	All set-ups	FALSE	0	Int16
16-72	Counter A	0 N/A	All set-ups	TRUE	0	Int32
16-73	Counter B	0 N/A	All set-ups	TRUE	0	Int32
16-75	Analog In X30/11	0.000 N/A	All set-ups	FALSE	-3	Int32
16-76	Analog In X30/12	0.000 N/A	All set-ups	FALSE	-3	Int32
16-77	Analog Out X30/8 [mA]	0.000 N/A	All set-ups	FALSE	-3	Int16
16-8* Fieldbus & FC Port						
16-80	Fieldbus CTW 1	0 N/A	All set-ups	FALSE	0	V2
16-82	Fieldbus REF 1	0 N/A	All set-ups	FALSE	0	N2
16-84	Comm. Option STW	0 N/A	All set-ups	FALSE	0	V2
16-85	FC Port CTW 1	0 N/A	All set-ups	FALSE	0	V2
16-86	FC Port REF 1	0 N/A	All set-ups	FALSE	0	N2
16-9* Diagnosis Readouts						
16-90	Alarm Word	0 N/A	All set-ups	FALSE	0	Uint32
16-91	Alarm Word 2	0 N/A	All set-ups	FALSE	0	Uint32
16-92	Warning Word	0 N/A	All set-ups	FALSE	0	Uint32
16-93	Warning Word 2	0 N/A	All set-ups	FALSE	0	Uint32
16-94	Ext. Status Word	0 N/A	All set-ups	FALSE	0	Uint32
16-95	Ext. Status Word 2	0 N/A	All set-ups	FALSE	0	Uint32
16-96	Maintenance Word	0 N/A	All set-ups	FALSE	0	Uint32

Table 6.24

6.3.17 18-** Info & Readouts

Par. No. #	Parameter description	Default value	4-set-up	Change during operation	Conversion index	Type
18-0* Maintenance Log						
18-00	Maintenance Log: Item	0 N/A	All set-ups	FALSE	0	Uint8

Par. No. #	Parameter description	Default value	4-set-up	Change during operation	Conversion index	Type
18-01	Maintenance Log: Action	0 N/A	All set-ups	FALSE	0	UInt8
18-02	Maintenance Log: Time	0 s	All set-ups	FALSE	0	UInt32
18-03	Maintenance Log: Date and Time	ExpressionLimit	All set-ups	FALSE	0	TimeOf Day
18-1* Fire Mode Log						
18-10	Fire Mode Log: Event	0 N/A	All set-ups	FALSE	0	UInt8
18-11	Fire Mode Log: Time	0 s	All set-ups	FALSE	0	UInt32
18-12	Fire Mode Log: Date and Time	ExpressionLimit	All set-ups	FALSE	0	TimeOf Day
18-3* Inputs & Outputs						
18-30	Analog Input X42/1	0.000 N/A	All set-ups	FALSE	-3	Int32
18-31	Analog Input X42/3	0.000 N/A	All set-ups	FALSE	-3	Int32
18-32	Analog Input X42/5	0.000 N/A	All set-ups	FALSE	-3	Int32
18-33	Analog Out X42/7 [V]	0.000 N/A	All set-ups	FALSE	-3	Int16
18-34	Analog Out X42/9 [V]	0.000 N/A	All set-ups	FALSE	-3	Int16
18-35	Analog Out X42/11 [V]	0.000 N/A	All set-ups	FALSE	-3	Int16
18-36	Analog Input X48/2 [mA]	0.000 N/A	All set-ups	TRUE	-3	Int32
18-37	Temp. Input X48/4	0 N/A	All set-ups	TRUE	0	Int16
18-38	Temp. Input X48/7	0 N/A	All set-ups	TRUE	0	Int16
18-39	Temp. Input X48/10	0 N/A	All set-ups	TRUE	0	Int16
18-5* Ref. & Feedb.						
18-50	Sensorless Readout [unit]	0.000 SensorlessUnit	All set-ups	FALSE	-3	Int32

Table 6.25

6.3.18 20-** FC Closed Loop

Par. No. #	Parameter description	Default value	4-set-up	Change during operation	Conversion index	Type
20-0* Feedback						
20-00	Feedback 1 Source	[2] Analog input 54	All set-ups	TRUE	-	UInt8
20-01	Feedback 1 Conversion	[0] Linear	All set-ups	FALSE	-	UInt8
20-02	Feedback 1 Source Unit	ExpressionLimit	All set-ups	TRUE	-	UInt8
20-03	Feedback 2 Source	[0] No function	All set-ups	TRUE	-	UInt8
20-04	Feedback 2 Conversion	[0] Linear	All set-ups	FALSE	-	UInt8
20-05	Feedback 2 Source Unit	ExpressionLimit	All set-ups	TRUE	-	UInt8
20-06	Feedback 3 Source	[0] No function	All set-ups	TRUE	-	UInt8
20-07	Feedback 3 Conversion	[0] Linear	All set-ups	FALSE	-	UInt8
20-08	Feedback 3 Source Unit	ExpressionLimit	All set-ups	TRUE	-	UInt8
20-12	Reference/Feedback Unit	ExpressionLimit	All set-ups	TRUE	-	UInt8
20-13	Minimum Reference/Feedb.	0.000 ProcessCtrlUnit	All set-ups	TRUE	-3	Int32
20-14	Maximum Reference/Feedb.	100.000 ProcessCtrlUnit	All set-ups	TRUE	-3	Int32
20-2* Feedback/Setpoint						
20-20	Feedback Function	[3] Minimum	All set-ups	TRUE	-	UInt8
20-21	Setpoint 1	0.000 ProcessCtrlUnit	All set-ups	TRUE	-3	Int32
20-22	Setpoint 2	0.000 ProcessCtrlUnit	All set-ups	TRUE	-3	Int32
20-23	Setpoint 3	0.000 ProcessCtrlUnit	All set-ups	TRUE	-3	Int32
20-3* Feedb. Adv. Conv.						
20-30	Refrigerant	[0] R22	All set-ups	TRUE	-	UInt8
20-31	User Defined Refrigerant A1	10.0000 N/A	All set-ups	TRUE	-4	UInt32

Par. No. #	Parameter description	Default value	4-set-up	Change during operation	Conversion index	Type
20-32	User Defined Refrigerant A2	-2250.00 N/A	All set-ups	TRUE	-2	Int32
20-33	User Defined Refrigerant A3	250.000 N/A	All set-ups	TRUE	-3	UInt32
20-34	Duct 1 Area [m2]	0.500 m2	All set-ups	TRUE	-3	UInt32
20-35	Duct 1 Area [in2]	750 in2	All set-ups	TRUE	0	UInt32
20-36	Duct 2 Area [m2]	0.500 m2	All set-ups	TRUE	-3	UInt32
20-37	Duct 2 Area [in2]	750 in2	All set-ups	TRUE	0	UInt32
20-38	Air Density Factor [%]	100 %	All set-ups	TRUE	0	UInt32
20-6* Sensorless						
20-60	Sensorless Unit	ExpressionLimit	All set-ups	TRUE	-	UInt8
20-69	Sensorless Information	0 N/A	All set-ups	TRUE	0	VisStr[25]
20-7* PID Autotuning						
20-70	Closed Loop Type	[0] Auto	2 set-ups	TRUE	-	UInt8
20-71	PID Performance	[0] Normal	2 set-ups	TRUE	-	UInt8
20-72	PID Output Change	0.10 N/A	2 set-ups	TRUE	-2	UInt16
20-73	Minimum Feedback Level	-999999.000 ProcessCtrlUnit	2 set-ups	TRUE	-3	Int32
20-74	Maximum Feedback Level	999999.000 ProcessCtrlUnit	2 set-ups	TRUE	-3	Int32
20-79	PID Autotuning	[0] Disabled	All set-ups	TRUE	-	UInt8
20-8* PID Basic Settings						
20-81	PID Normal/ Inverse Control	[0] Normal	All set-ups	TRUE	-	UInt8
20-82	PID Start Speed [RPM]	ExpressionLimit	All set-ups	TRUE	67	UInt16
20-83	PID Start Speed [Hz]	ExpressionLimit	All set-ups	TRUE	-1	UInt16
20-84	On Reference Bandwidth	5 %	All set-ups	TRUE	0	UInt8
20-9* PID Controller						
20-91	PID Anti Windup	[1] On	All set-ups	TRUE	-	UInt8
20-93	PID Proportional Gain	0.50 N/A	All set-ups	TRUE	-2	UInt16
20-94	PID Integral Time	20.00 s	All set-ups	TRUE	-2	UInt32
20-95	PID Differentiation Time	0.00 s	All set-ups	TRUE	-2	UInt16
20-96	PID Diff. Gain Limit	5.0 N/A	All set-ups	TRUE	-1	UInt16

Table 6.26

6.3.19 21-** Ext. Closed Loop

Par. No. #	Parameter description	Default value	4-set-up	Change during operation	Conversion index	Type
21-0* Ext. CL Autotuning						
21-00	Closed Loop Type	[0] Auto	2 set-ups	TRUE	-	UInt8
21-01	PID Performance	[0] Normal	2 set-ups	TRUE	-	UInt8
21-02	PID Output Change	0.10 N/A	2 set-ups	TRUE	-2	UInt16
21-03	Minimum Feedback Level	-999999.000 N/A	2 set-ups	TRUE	-3	Int32
21-04	Maximum Feedback Level	999999.000 N/A	2 set-ups	TRUE	-3	Int32
21-09	PID Autotuning	[0] Disabled	All set-ups	TRUE	-	UInt8
21-1* Ext. CL 1 Ref./Fb.						
21-10	Ext. 1 Ref./Feedback Unit	[1] %	All set-ups	TRUE	-	UInt8
21-11	Ext. 1 Minimum Reference	0.000 ExtPID1Unit	All set-ups	TRUE	-3	Int32
21-12	Ext. 1 Maximum Reference	100.000 ExtPID1Unit	All set-ups	TRUE	-3	Int32
21-13	Ext. 1 Reference Source	[0] No function	All set-ups	TRUE	-	UInt8
21-14	Ext. 1 Feedback Source	[0] No function	All set-ups	TRUE	-	UInt8
21-15	Ext. 1 Setpoint	0.000 ExtPID1Unit	All set-ups	TRUE	-3	Int32
21-17	Ext. 1 Reference [Unit]	0.000 ExtPID1Unit	All set-ups	TRUE	-3	Int32

Par. No. #	Parameter description	Default value	4-set-up	Change during operation	Conversion index	Type
21-18	Ext. 1 Feedback [Unit]	0.000 ExtPID1Unit	All set-ups	TRUE	-3	Int32
21-19	Ext. 1 Output [%]	0 %	All set-ups	TRUE	0	Int32
21-2* Ext. CL 1 PID						
21-20	Ext. 1 Normal/Inverse Control	[0] Normal	All set-ups	TRUE	-	UInt8
21-21	Ext. 1 Proportional Gain	0.01 N/A	All set-ups	TRUE	-2	UInt16
21-22	Ext. 1 Integral Time	10000.00 s	All set-ups	TRUE	-2	UInt32
21-23	Ext. 1 Differentiation Time	0.00 s	All set-ups	TRUE	-2	UInt16
21-24	Ext. 1 Dif. Gain Limit	5.0 N/A	All set-ups	TRUE	-1	UInt16
21-3* Ext. CL 2 Ref./Fb.						
21-30	Ext. 2 Ref./Feedback Unit	[1] %	All set-ups	TRUE	-	UInt8
21-31	Ext. 2 Minimum Reference	0.000 ExtPID2Unit	All set-ups	TRUE	-3	Int32
21-32	Ext. 2 Maximum Reference	100.000 ExtPID2Unit	All set-ups	TRUE	-3	Int32
21-33	Ext. 2 Reference Source	[0] No function	All set-ups	TRUE	-	UInt8
21-34	Ext. 2 Feedback Source	[0] No function	All set-ups	TRUE	-	UInt8
21-35	Ext. 2 Setpoint	0.000 ExtPID2Unit	All set-ups	TRUE	-3	Int32
21-37	Ext. 2 Reference [Unit]	0.000 ExtPID2Unit	All set-ups	TRUE	-3	Int32
21-38	Ext. 2 Feedback [Unit]	0.000 ExtPID2Unit	All set-ups	TRUE	-3	Int32
21-39	Ext. 2 Output [%]	0 %	All set-ups	TRUE	0	Int32
21-4* Ext. CL 2 PID						
21-40	Ext. 2 Normal/Inverse Control	[0] Normal	All set-ups	TRUE	-	UInt8
21-41	Ext. 2 Proportional Gain	0.01 N/A	All set-ups	TRUE	-2	UInt16
21-42	Ext. 2 Integral Time	10000.00 s	All set-ups	TRUE	-2	UInt32
21-43	Ext. 2 Differentiation Time	0.00 s	All set-ups	TRUE	-2	UInt16
21-44	Ext. 2 Dif. Gain Limit	5.0 N/A	All set-ups	TRUE	-1	UInt16
21-5* Ext. CL 3 Ref./Fb.						
21-50	Ext. 3 Ref./Feedback Unit	[1] %	All set-ups	TRUE	-	UInt8
21-51	Ext. 3 Minimum Reference	0.000 ExtPID3Unit	All set-ups	TRUE	-3	Int32
21-52	Ext. 3 Maximum Reference	100.000 ExtPID3Unit	All set-ups	TRUE	-3	Int32
21-53	Ext. 3 Reference Source	[0] No function	All set-ups	TRUE	-	UInt8
21-54	Ext. 3 Feedback Source	[0] No function	All set-ups	TRUE	-	UInt8
21-55	Ext. 3 Setpoint	0.000 ExtPID3Unit	All set-ups	TRUE	-3	Int32
21-57	Ext. 3 Reference [Unit]	0.000 ExtPID3Unit	All set-ups	TRUE	-3	Int32
21-58	Ext. 3 Feedback [Unit]	0.000 ExtPID3Unit	All set-ups	TRUE	-3	Int32
21-59	Ext. 3 Output [%]	0 %	All set-ups	TRUE	0	Int32
21-6* Ext. CL 3 PID						
21-60	Ext. 3 Normal/Inverse Control	[0] Normal	All set-ups	TRUE	-	UInt8
21-61	Ext. 3 Proportional Gain	0.01 N/A	All set-ups	TRUE	-2	UInt16
21-62	Ext. 3 Integral Time	10000.00 s	All set-ups	TRUE	-2	UInt32
21-63	Ext. 3 Differentiation Time	0.00 s	All set-ups	TRUE	-2	UInt16
21-64	Ext. 3 Dif. Gain Limit	5.0 N/A	All set-ups	TRUE	-1	UInt16

Table 6.27

6.3.20 22-** Application Functions

Par. No. #	Parameter description	Default value	4-set-up	Change during operation	Conversion index	Type
22-0* Miscellaneous						
22-00	External Interlock Delay	0 s	All set-ups	TRUE	0	UInt16
22-01	Power Filter Time	0.50 s	2 set-ups	TRUE	-2	UInt16

Par. No. #	Parameter description	Default value	4-set-up	Change during operation	Conversion index	Type
22-2* No-Flow Detection						
22-20	Low Power Auto Set-up	[0] Off	All set-ups	FALSE	-	Uint8
22-21	Low Power Detection	[0] Disabled	All set-ups	TRUE	-	Uint8
22-22	Low Speed Detection	[0] Disabled	All set-ups	TRUE	-	Uint8
22-23	No-Flow Function	[0] Off	All set-ups	TRUE	-	Uint8
22-24	No-Flow Delay	10 s	All set-ups	TRUE	0	Uint16
22-26	Dry Pump Function	[0] Off	All set-ups	TRUE	-	Uint8
22-27	Dry Pump Delay	10 s	All set-ups	TRUE	0	Uint16
22-3* No-Flow Power Tuning						
22-30	No-Flow Power	0.00 kW	All set-ups	TRUE	1	Uint32
22-31	Power Correction Factor	100 %	All set-ups	TRUE	0	Uint16
22-32	Low Speed [RPM]	ExpressionLimit	All set-ups	TRUE	67	Uint16
22-33	Low Speed [Hz]	ExpressionLimit	All set-ups	TRUE	-1	Uint16
22-34	Low Speed Power [kW]	ExpressionLimit	All set-ups	TRUE	1	Uint32
22-35	Low Speed Power [HP]	ExpressionLimit	All set-ups	TRUE	-2	Uint32
22-36	High Speed [RPM]	ExpressionLimit	All set-ups	TRUE	67	Uint16
22-37	High Speed [Hz]	ExpressionLimit	All set-ups	TRUE	-1	Uint16
22-38	High Speed Power [kW]	ExpressionLimit	All set-ups	TRUE	1	Uint32
22-39	High Speed Power [HP]	ExpressionLimit	All set-ups	TRUE	-2	Uint32
22-4* Sleep Mode						
22-40	Minimum Run Time	10 s	All set-ups	TRUE	0	Uint16
22-41	Minimum Sleep Time	10 s	All set-ups	TRUE	0	Uint16
22-42	Wake-up Speed [RPM]	ExpressionLimit	All set-ups	TRUE	67	Uint16
22-43	Wake-up Speed [Hz]	ExpressionLimit	All set-ups	TRUE	-1	Uint16
22-44	Wake-up Ref./FB Difference	10 %	All set-ups	TRUE	0	Int8
22-45	Setpoint Boost	0 %	All set-ups	TRUE	0	Int8
22-46	Maximum Boost Time	60 s	All set-ups	TRUE	0	Uint16
22-5* End of Curve						
22-50	End of Curve Function	[0] Off	All set-ups	TRUE	-	Uint8
22-51	End of Curve Delay	10 s	All set-ups	TRUE	0	Uint16
22-6* Broken Belt Detection						
22-60	Broken Belt Function	[0] Off	All set-ups	TRUE	-	Uint8
22-61	Broken Belt Torque	10 %	All set-ups	TRUE	0	Uint8
22-62	Broken Belt Delay	10 s	All set-ups	TRUE	0	Uint16
22-7* Short Cycle Protection						
22-75	Short Cycle Protection	[0] Disabled	All set-ups	TRUE	-	Uint8
22-76	Interval between Starts	Param. 2277	All set-ups	TRUE	0	Uint16
22-77	Minimum Run Time	0 s	All set-ups	TRUE	0	Uint16
22-78	Minimum Run Time Override	[0] Disabled	All set-ups	FALSE	-	Uint8
22-79	Minimum Run Time Override Value	0.000 ProcessCtrlUnit	All set-ups	TRUE	-3	Int32
22-8* Flow Compensation						
22-80	Flow Compensation	[0] Disabled	All set-ups	TRUE	-	Uint8
22-81	Square-linear Curve Approximation	100 %	All set-ups	TRUE	0	Uint8
22-82	Work Point Calculation	[0] Disabled	All set-ups	TRUE	-	Uint8
22-83	Speed at No-Flow [RPM]	ExpressionLimit	All set-ups	TRUE	67	Uint16
22-84	Speed at No-Flow [Hz]	ExpressionLimit	All set-ups	TRUE	-1	Uint16
22-85	Speed at Design Point [RPM]	ExpressionLimit	All set-ups	TRUE	67	Uint16
22-86	Speed at Design Point [Hz]	ExpressionLimit	All set-ups	TRUE	-1	Uint16
22-87	Pressure at No-Flow Speed	0.000 N/A	All set-ups	TRUE	-3	Int32
22-88	Pressure at Rated Speed	999999.999 N/A	All set-ups	TRUE	-3	Int32
22-89	Flow at Design Point	0.000 N/A	All set-ups	TRUE	-3	Int32

Par. No. #	Parameter description	Default value	4-set-up	Change during operation	Conversion index	Type
22-90	Flow at Rated Speed	0.000 N/A	All set-ups	TRUE	-3	Int32

Table 6.28

6.3.21 23-** Time Based Functions

Par. No. #	Parameter description	Default value	4-set-up	Change during operation	Conversion index	Type
23-0* Timed Actions						
23-00	ON Time	ExpressionLimit	2 set-ups	TRUE	0	TimeOfDay-WoDate
23-01	ON Action	[0] Disabled	2 set-ups	TRUE	-	UInt8
23-02	OFF Time	ExpressionLimit	2 set-ups	TRUE	0	TimeOfDay-WoDate
23-03	OFF Action	[1] No action	2 set-ups	TRUE	-	UInt8
23-04	Occurrence	[0] All days	2 set-ups	TRUE	-	UInt8
23-0* Timed Actions Settings						
23-08	Timed Actions Mode	[0] Timed Actions Auto	2 set-ups	TRUE	-	UInt8
23-09	Timed Actions Reactivation	[1] Enabled	2 set-ups	TRUE	-	UInt8
23-1* Maintenance						
23-10	Maintenance Item	[1] Motor bearings	1 set-up	TRUE	-	UInt8
23-11	Maintenance Action	[1] Lubricate	1 set-up	TRUE	-	UInt8
23-12	Maintenance Time Base	[0] Disabled	1 set-up	TRUE	-	UInt8
23-13	Maintenance Time Interval	1 h	1 set-up	TRUE	74	UInt32
23-14	Maintenance Date and Time	ExpressionLimit	1 set-up	TRUE	0	TimeOfDay
23-1* Maintenance Reset						
23-15	Reset Maintenance Word	[0] Do not reset	All set-ups	TRUE	-	UInt8
23-16	Maintenance Text	0 N/A	1 set-up	TRUE	0	VisStr[20]
23-5* Energy Log						
23-50	Energy Log Resolution	[5] Last 24 Hours	2 set-ups	TRUE	-	UInt8
23-51	Period Start	ExpressionLimit	2 set-ups	TRUE	0	TimeOfDay
23-53	Energy Log	0 N/A	All set-ups	TRUE	0	UInt32
23-54	Reset Energy Log	[0] Do not reset	All set-ups	TRUE	-	UInt8
23-6* Trending						
23-60	Trend Variable	[0] Power [kW]	2 set-ups	TRUE	-	UInt8
23-61	Continuous Bin Data	0 N/A	All set-ups	TRUE	0	UInt32
23-62	Timed Bin Data	0 N/A	All set-ups	TRUE	0	UInt32
23-63	Timed Period Start	ExpressionLimit	2 set-ups	TRUE	0	TimeOfDay
23-64	Timed Period Stop	ExpressionLimit	2 set-ups	TRUE	0	TimeOfDay
23-65	Minimum Bin Value	ExpressionLimit	2 set-ups	TRUE	0	UInt8
23-66	Reset Continuous Bin Data	[0] Do not reset	All set-ups	TRUE	-	UInt8
23-67	Reset Timed Bin Data	[0] Do not reset	All set-ups	TRUE	-	UInt8
23-8* Payback Counter						
23-80	Power Reference Factor	100 %	2 set-ups	TRUE	0	UInt8
23-81	Energy Cost	1.00 N/A	2 set-ups	TRUE	-2	UInt32
23-82	Investment	0 N/A	2 set-ups	TRUE	0	UInt32
23-83	Energy Savings	0 kWh	All set-ups	TRUE	75	Int32
23-84	Cost Savings	0 N/A	All set-ups	TRUE	0	Int32

Table 6.29

6.3.22 24-** Application Functions 2

Par. No. #	Parameter description	Default value	4-set-up	Change during operation	Conversion index	Type
24-0* Fire Mode						
24-00	Fire Mode Function	[0] Disabled	2 set-ups	TRUE	-	Uint8
24-01	Fire Mode Configuration	[0] Open Loop	All set-ups	TRUE	-	Uint8
24-02	Fire Mode Unit	ExpressionLimit	All set-ups	TRUE	-	Uint8
24-03	Fire Mode Min Reference	ExpressionLimit	All set-ups	TRUE	-3	Int32
24-04	Fire Mode Max Reference	ExpressionLimit	All set-ups	TRUE	-3	Int32
24-05	Fire Mode Preset Reference	0.00 %	All set-ups	TRUE	-2	Int16
24-06	Fire Mode Reference Source	[0] No function	All set-ups	TRUE	-	Uint8
24-07	Fire Mode Feedback Source	[0] No function	All set-ups	TRUE	-	Uint8
24-09	Fire Mode Alarm Handling	[1] Trip, Critical Alarms	2 set-ups	FALSE	-	Uint8
24-1* Drive Bypass						
24-10	Drive Bypass Function	[0] Disabled	2 set-ups	TRUE	-	Uint8
24-11	Drive Bypass Delay Time	0 s	2 set-ups	TRUE	0	Uint16
24-9* Multi-Motor Funct.						
24-90	Missing Motor Function	[0] Off	All set-ups	TRUE	-	Uint8
24-91	Missing Motor Coefficient 1	0.0000 N/A	All set-ups	TRUE	-4	Int32
24-92	Missing Motor Coefficient 2	0.0000 N/A	All set-ups	TRUE	-4	Int32
24-93	Missing Motor Coefficient 3	0.0000 N/A	All set-ups	TRUE	-4	Int32
24-94	Missing Motor Coefficient 4	0.000 N/A	All set-ups	TRUE	-3	Int32
24-95	Locked Rotor Function	[0] Off	All set-ups	TRUE	-	Uint8
24-96	Locked Rotor Coefficient 1	0.0000 N/A	All set-ups	TRUE	-4	Int32
24-97	Locked Rotor Coefficient 2	0.0000 N/A	All set-ups	TRUE	-4	Int32
24-98	Locked Rotor Coefficient 3	0.0000 N/A	All set-ups	TRUE	-4	Int32
24-99	Locked Rotor Coefficient 4	0.000 N/A	All set-ups	TRUE	-3	Int32

Table 6.30

6.3.23 25-** Cascade Pack Controller

Par. No. #	Parameter description	Default value	4-set-up	Change during operation	Conversion index	Type
25-0* System Settings						
25-00	Cascade Controller	[0] Disabled	2 set-ups	FALSE	-	Uint8
25-02	Motor Start	[0] Direct on Line	2 set-ups	FALSE	-	Uint8
25-04	Pump Cycling	[0] Disabled	All set-ups	TRUE	-	Uint8
25-05	Fixed Lead Pump	[1] Yes	2 set-ups	FALSE	-	Uint8
25-06	Number of Pumps	2 N/A	2 set-ups	FALSE	0	Uint8
25-2* Bandwidth Settings						
25-20	Staging Bandwidth	10 %	All set-ups	TRUE	0	Uint8
25-21	Override Bandwidth	100 %	All set-ups	TRUE	0	Uint8
25-22	Fixed Speed Bandwidth	Param. 2520	All set-ups	TRUE	0	Uint8
25-23	SBW Staging Delay	15 s	All set-ups	TRUE	0	Uint16
25-24	SBW Destaging Delay	15 s	All set-ups	TRUE	0	Uint16
25-25	OBW Time	10 s	All set-ups	TRUE	0	Uint16
25-26	Destage At No-Flow	[0] Disabled	All set-ups	TRUE	-	Uint8
25-27	Stage Function	[1] Enabled	All set-ups	TRUE	-	Uint8
25-28	Stage Function Time	15 s	All set-ups	TRUE	0	Uint16
25-29	Destage Function	[1] Enabled	All set-ups	TRUE	-	Uint8

Par. No. #	Parameter description	Default value	4-set-up	Change during operation	Conversion index	Type
25-30	Destage Function Time	15 s	All set-ups	TRUE	0	Uint16
25-4* Staging Settings						
25-40	Ramp Down Delay	10.0 s	All set-ups	TRUE	-1	Uint16
25-41	Ramp Up Delay	2.0 s	All set-ups	TRUE	-1	Uint16
25-42	Staging Threshold	ExpressionLimit	All set-ups	TRUE	0	Uint8
25-43	Destaging Threshold	ExpressionLimit	All set-ups	TRUE	0	Uint8
25-44	Staging Speed [RPM]	0 RPM	All set-ups	TRUE	67	Uint16
25-45	Staging Speed [Hz]	0.0 Hz	All set-ups	TRUE	-1	Uint16
25-46	Destaging Speed [RPM]	0 RPM	All set-ups	TRUE	67	Uint16
25-47	Destaging Speed [Hz]	0.0 Hz	All set-ups	TRUE	-1	Uint16
25-5* Alternation Settings						
25-50	Lead Pump Alternation	[0] Off	All set-ups	TRUE	-	Uint8
25-51	Alternation Event	[0] External	All set-ups	TRUE	-	Uint8
25-52	Alternation Time Interval	24 h	All set-ups	TRUE	74	Uint16
25-53	Alternation Timer Value	0 N/A	All set-ups	TRUE	0	VisStr[7]
25-54	Alternation Predefined Time	ExpressionLimit	All set-ups	TRUE	0	TimeOfDay-WoDate
25-55	Alternate if Load < 50%	[1] Enabled	All set-ups	TRUE	-	Uint8
25-56	Staging Mode at Alternation	[0] Slow	All set-ups	TRUE	-	Uint8
25-58	Run Next Pump Delay	0.1 s	All set-ups	TRUE	-1	Uint16
25-59	Run on Mains Delay	0.5 s	All set-ups	TRUE	-1	Uint16
25-8* Status						
25-80	Cascade Status	0 N/A	All set-ups	TRUE	0	VisStr[25]
25-81	Pump Status	0 N/A	All set-ups	TRUE	0	VisStr[25]
25-82	Lead Pump	0 N/A	All set-ups	TRUE	0	Uint8
25-83	Relay Status	0 N/A	All set-ups	TRUE	0	VisStr[4]
25-84	Pump ON Time	0 h	All set-ups	TRUE	74	Uint32
25-85	Relay ON Time	0 h	All set-ups	TRUE	74	Uint32
25-86	Reset Relay Counters	[0] Do not reset	All set-ups	TRUE	-	Uint8
25-9* Service						
25-90	Pump Interlock	[0] Off	All set-ups	TRUE	-	Uint8
25-91	Manual Alternation	0 N/A	All set-ups	TRUE	0	Uint8

Table 6.31

6.3.24 26-** Analog I / O Option MCB 109

Par. No. #	Parameter description	Default value	4-set-up	Change during operation	Conversion index	Type
26-0* Analog I/O Mode						
26-00	Terminal X42/1 Mode	[1] Voltage	All set-ups	TRUE	-	Uint8
26-01	Terminal X42/3 Mode	[1] Voltage	All set-ups	TRUE	-	Uint8
26-02	Terminal X42/5 Mode	[1] Voltage	All set-ups	TRUE	-	Uint8
26-1* Analog Input X42/1						
26-10	Terminal X42/1 Low Voltage	0.07 V	All set-ups	TRUE	-2	Int16
26-11	Terminal X42/1 High Voltage	10.00 V	All set-ups	TRUE	-2	Int16
26-14	Term. X42/1 Low Ref./Feedb. Value	0.000 N/A	All set-ups	TRUE	-3	Int32
26-15	Term. X42/1 High Ref./Feedb. Value	100.000 N/A	All set-ups	TRUE	-3	Int32
26-16	Term. X42/1 Filter Time Constant	0.001 s	All set-ups	TRUE	-3	Uint16
26-17	Term. X42/1 Live Zero	[1] Enabled	All set-ups	TRUE	-	Uint8

Par. No. #	Parameter description	Default value	4-set-up	Change during operation	Conversion index	Type
26-2* Analog Input X42/3						
26-20	Terminal X42/3 Low Voltage	0.07 V	All set-ups	TRUE	-2	Int16
26-21	Terminal X42/3 High Voltage	10.00 V	All set-ups	TRUE	-2	Int16
26-24	Term. X42/3 Low Ref./Feedb. Value	0.000 N/A	All set-ups	TRUE	-3	Int32
26-25	Term. X42/3 High Ref./Feedb. Value	100.000 N/A	All set-ups	TRUE	-3	Int32
26-26	Term. X42/3 Filter Time Constant	0.001 s	All set-ups	TRUE	-3	UInt16
26-27	Term. X42/3 Live Zero	[1] Enabled	All set-ups	TRUE	-	UInt8
26-3* Analog Input X42/5						
26-30	Terminal X42/5 Low Voltage	0.07 V	All set-ups	TRUE	-2	Int16
26-31	Terminal X42/5 High Voltage	10.00 V	All set-ups	TRUE	-2	Int16
26-34	Term. X42/5 Low Ref./Feedb. Value	0.000 N/A	All set-ups	TRUE	-3	Int32
26-35	Term. X42/5 High Ref./Feedb. Value	100.000 N/A	All set-ups	TRUE	-3	Int32
26-36	Term. X42/5 Filter Time Constant	0.001 s	All set-ups	TRUE	-3	UInt16
26-37	Term. X42/5 Live Zero	[1] Enabled	All set-ups	TRUE	-	UInt8
26-4* Analog Out X42/7						
26-40	Terminal X42/7 Output	[0] No operation	All set-ups	TRUE	-	UInt8
26-41	Terminal X42/7 Min. Scale	0.00 %	All set-ups	TRUE	-2	Int16
26-42	Terminal X42/7 Max. Scale	100.00 %	All set-ups	TRUE	-2	Int16
26-43	Terminal X42/7 Bus Control	0.00 %	All set-ups	TRUE	-2	N2
26-44	Terminal X42/7 Timeout Preset	0.00 %	1 set-up	TRUE	-2	UInt16
26-5* Analog Out X42/9						
26-50	Terminal X42/9 Output	[0] No operation	All set-ups	TRUE	-	UInt8
26-51	Terminal X42/9 Min. Scale	0.00 %	All set-ups	TRUE	-2	Int16
26-52	Terminal X42/9 Max. Scale	100.00 %	All set-ups	TRUE	-2	Int16
26-53	Terminal X42/9 Bus Control	0.00 %	All set-ups	TRUE	-2	N2
26-54	Terminal X42/9 Timeout Preset	0.00 %	1 set-up	TRUE	-2	UInt16
26-6* Analog Out X42/11						
26-60	Terminal X42/11 Output	[0] No operation	All set-ups	TRUE	-	UInt8
26-61	Terminal X42/11 Min. Scale	0.00 %	All set-ups	TRUE	-2	Int16
26-62	Terminal X42/11 Max. Scale	100.00 %	All set-ups	TRUE	-2	Int16
26-63	Terminal X42/11 Bus Control	0.00 %	All set-ups	TRUE	-2	N2
26-64	Terminal X42/11 Timeout Preset	0.00 %	1 set-up	TRUE	-2	UInt16

Table 6.32

6.4 Parameter Lists - Active Filter

6.4.1 0-** Operation/Display

Par. No. #	Parameter description	Default value	4-set-up	Change during operation	Conversion index	Type
0-0* Basic Settings						
0-01	Language	[0] English	1 set-up	TRUE	-	UInt8
0-04	Operating State at Power-up (Hand)	[1] Forced stop	All set-ups	TRUE	-	UInt8
0-1* Set-up Operations						
0-10	Active Set-up	[1] Set-up 1	1 set-up	TRUE	-	UInt8
0-11	Edit Set-up	[1] Set-up 1	All set-ups	TRUE	-	UInt8
0-12	This Set-up Linked to	[0] Not linked	All set-ups	FALSE	-	UInt8
0-13	Readout: Linked Set-ups	0 N/A	All set-ups	FALSE	0	UInt16

0-14	Readout: Edit Set-ups / Channel	0 N/A	All set-ups	TRUE	0	Int32
0-2* LCP Display						
0-20	Display Line 1.1 Small	30112	All set-ups	TRUE	-	UInt16
0-21	Display Line 1.2 Small	30110	All set-ups	TRUE	-	UInt16
0-22	Display Line 1.3 Small	30120	All set-ups	TRUE	-	UInt16
0-23	Display Line 2 Large	30100	All set-ups	TRUE	-	UInt16
0-24	Display Line 3 Large	30121	All set-ups	TRUE	-	UInt16
0-25	My Personal Menu	ExpressionLimit	1 set-up	TRUE	0	UInt16
0-4* LCP Keypad						
0-40	[Hand on] Key on LCP	[1] Enabled	All set-ups	TRUE	-	UInt8
0-41	[Off] Key on LCP	[1] Enabled	All set-ups	TRUE	-	UInt8
0-42	[Auto on] Key on LCP	[1] Enabled	All set-ups	TRUE	-	UInt8
0-43	[Reset] Key on LCP	[1] Enabled	All set-ups	TRUE	-	UInt8
0-5* Copy/Save						
0-50	LCP Copy	[0] No copy	All set-ups	FALSE	-	UInt8
0-51	Set-up Copy	[0] No copy	All set-ups	FALSE	-	UInt8
0-6* Password						
0-60	Main Menu Password	100 N/A	1 set-up	TRUE	0	Int16
0-61	Access to Main Menu w/o Password	[0] Full access	1 set-up	TRUE	-	UInt8
0-65	Quick Menu Password	200 N/A	1 set-up	TRUE	0	Int16
0-66	Access to Quick Menu w/o Password	[0] Full access	1 set-up	TRUE	-	UInt8

Table 6.33

6.4.2 5-** Digital In/Out

Par. No. #	Parameter description	Default value	4-set-up	Change during operation	Conversion index	Type
5-0* Digital I/O mode						
5-00	Digital I/O Mode	[0] PNP	All set-ups	FALSE	-	UInt8
5-01	Terminal 27 Mode	[0] Input	All set-ups	TRUE	-	UInt8
5-02	Terminal 29 Mode	[0] Input	All set-ups	TRUE	-	UInt8
5-1* Digital Inputs						
5-10	Terminal 18 Digital Input	[8] Start	All set-ups	TRUE	-	UInt8
5-11	Terminal 19 Digital Input	[0] No operation	All set-ups	TRUE	-	UInt8
5-12	Terminal 27 Digital Input	[0] No operation	All set-ups	TRUE	-	UInt8
5-13	Terminal 29 Digital Input	[0] No operation	All set-ups	TRUE	-	UInt8
5-14	Terminal 32 Digital Input	[90] AC Contactor	All set-ups	TRUE	-	UInt8
5-15	Terminal 33 Digital Input	[91] DC Contactor	All set-ups	TRUE	-	UInt8
5-16	Terminal X30/2 Digital Input	[0] No operation	All set-ups	TRUE	-	UInt8
5-17	Terminal X30/3 Digital Input	[0] No operation	All set-ups	TRUE	-	UInt8
5-18	Terminal X30/4 Digital Input	[0] No operation	All set-ups	TRUE	-	UInt8
5-19	Terminal 37 Safe Stop	[1] Safe Stop Alarm	1 set-up	TRUE	-	UInt8
5-3* Digital Outputs						
5-30	Terminal 27 Digital Output	[0] No operation	All set-ups	TRUE	-	UInt8
5-31	Terminal 29 Digital Output	[0] No operation	All set-ups	TRUE	-	UInt8
5-4* Relays						
5-40	Function Relay	[0] No operation	All set-ups	TRUE	-	UInt8
5-41	On Delay, Relay	0.30 s	All set-ups	TRUE	-2	UInt16
5-42	Off Delay, Relay	0.30 s	All set-ups	TRUE	-2	UInt16

Table 6.34

6.4.3 8-** Comm. and Options

Par. No. #	Parameter description	Default value	4-set-up	Change during operation	Conversion index	Type
8-0* General Settings						
8-01	Control Site	[0] Digital and ctrl.word	All set-ups	TRUE	-	Uint8
8-02	Control Word Source	null	All set-ups	TRUE	-	Uint8
8-03	Control Word Timeout Time	1.0 s	1 set-up	TRUE	-1	Uint32
8-04	Control Word Timeout Function	[0] Off	1 set-up	TRUE	-	Uint8
8-05	End-of-Timeout Function	[1] Resume set-up	1 set-up	TRUE	-	Uint8
8-06	Reset Control Word Timeout	[0] Do not reset	All set-ups	TRUE	-	Uint8
8-3* FC Port Settings						
8-30	Protocol	[1] FC MC	1 set-up	TRUE	-	Uint8
8-31	Address	2 N/A	1 set-up	TRUE	0	Uint8
8-32	FC Port Baud Rate	[2] 9600 Baud	1 set-up	TRUE	-	Uint8
8-35	Minimum Response Delay	10 ms	All set-ups	TRUE	-3	Uint16
8-36	Max Response Delay	5000 ms	1 set-up	TRUE	-3	Uint16
8-37	Max Inter-Char Delay	25 ms	1 set-up	TRUE	-3	Uint16
8-5* Digital/Bus						
8-53	Start Select	[3] Logic OR	All set-ups	TRUE	-	Uint8
8-55	Set-up Select	[3] Logic OR	All set-ups	TRUE	-	Uint8

Table 6.35

6.4.4 14-** Special Functions

Par. No. #	Parameter description	Default value	4-set-up	Change during operation	Conversion index	Type
14-2* Trip Reset						
14-20	Reset Mode	[0] Manual reset	All set-ups	TRUE	-	Uint8
14-21	Automatic Restart Time	10 s	All set-ups	TRUE	0	Uint16
14-22	Operation Mode	[0] Normal operation	All set-ups	TRUE	-	Uint8
14-23	Typecode Setting	null	2 set-ups	FALSE	-	Uint8
14-28	Production Settings	[0] No action	All set-ups	TRUE	-	Uint8
14-29	Service Code	0 N/A	All set-ups	TRUE	0	Int32
14-5* Environment						
14-50	RFI Filter	[1] On	1 set-up	FALSE	-	Uint8
14-53	Fan Monitor	[1] Warning	All set-ups	TRUE	-	Uint8
14-54	Bus Partner	1 N/A	2 set-ups	TRUE	0	Uint16

Table 6.36

6.4.5 15-** FC Information

Par. No. #	Parameter description	Default value	4-set-up	Change during operation	Conversion index	Type
15-0* Operating Data						
15-00	Operating Hours	0 h	All set-ups	FALSE	74	Uint32
15-01	Running Hours	0 h	All set-ups	FALSE	74	Uint32
15-03	Power Up's	0 N/A	All set-ups	FALSE	0	Uint32
15-04	Over Temp's	0 N/A	All set-ups	FALSE	0	Uint16

Par. No. #	Parameter description	Default value	4-set-up	Change during operation	Conversion index	Type
15-05	Over Volt's	0 N/A	All set-ups	FALSE	0	Uint16
15-07	Reset Running Hours Counter	[0] Do not reset	All set-ups	TRUE	-	Uint8
15-1* Data Log Settings						
15-10	Logging Source	0	2 set-ups	TRUE	-	Uint16
15-11	Logging Interval	ExpressionLimit	2 set-ups	TRUE	-3	TimD
15-12	Trigger Event	[0] False	1 set-up	TRUE	-	Uint8
15-13	Logging Mode	[0] Log always	2 set-ups	TRUE	-	Uint8
15-14	Samples Before Trigger	50 N/A	2 set-ups	TRUE	0	Uint8
15-2* Historic Log						
15-20	Historic Log: Event	0 N/A	All set-ups	FALSE	0	Uint8
15-21	Historic Log: Value	0 N/A	All set-ups	FALSE	0	Uint32
15-22	Historic Log: Time	0 ms	All set-ups	FALSE	-3	Uint32
15-3* Fault Log						
15-30	Fault Log: Error Code	0 N/A	All set-ups	FALSE	0	Uint16
15-31	Fault Log: Value	0 N/A	All set-ups	FALSE	0	Int16
15-32	Fault Log: Time	0 s	All set-ups	FALSE	0	Uint32
15-4* Unit Identification						
15-40	FC Type	0 N/A	All set-ups	FALSE	0	VisStr[6]
15-41	Power Section	0 N/A	All set-ups	FALSE	0	VisStr[20]
15-42	Voltage	0 N/A	All set-ups	FALSE	0	VisStr[20]
15-43	Software Version	0 N/A	All set-ups	FALSE	0	VisStr[5]
15-44	Ordered Typecode String	0 N/A	All set-ups	FALSE	0	VisStr[40]
15-45	Actual Typecode String	0 N/A	All set-ups	FALSE	0	VisStr[40]
15-46	Unit Ordering No	0 N/A	All set-ups	FALSE	0	VisStr[8]
15-47	Power Card Ordering No	0 N/A	All set-ups	FALSE	0	VisStr[8]
15-48	LCP Id No	0 N/A	All set-ups	FALSE	0	VisStr[20]
15-49	SW ID Control Card	0 N/A	All set-ups	FALSE	0	VisStr[20]
15-50	SW ID Power Card	0 N/A	All set-ups	FALSE	0	VisStr[20]
15-51	Unit Serial Number	0 N/A	All set-ups	FALSE	0	VisStr[10]
15-53	Power Card Serial Number	0 N/A	All set-ups	FALSE	0	VisStr[19]
15-6* Option Ident						
15-60	Option Mounted	0 N/A	All set-ups	FALSE	0	VisStr[30]
15-61	Option SW Version	0 N/A	All set-ups	FALSE	0	VisStr[20]
15-62	Option Ordering No	0 N/A	All set-ups	FALSE	0	VisStr[8]
15-63	Option Serial No	0 N/A	All set-ups	FALSE	0	VisStr[18]
15-70	Option in Slot A	0 N/A	All set-ups	FALSE	0	VisStr[30]
15-71	Slot A Option SW Version	0 N/A	All set-ups	FALSE	0	VisStr[20]
15-72	Option in Slot B	0 N/A	All set-ups	FALSE	0	VisStr[30]
15-73	Slot B Option SW Version	0 N/A	All set-ups	FALSE	0	VisStr[20]
15-74	Option in Slot C0	0 N/A	All set-ups	FALSE	0	VisStr[30]
15-75	Slot C0 Option SW Version	0 N/A	All set-ups	FALSE	0	VisStr[20]
15-76	Option in Slot C1	0 N/A	All set-ups	FALSE	0	VisStr[30]
15-77	Slot C1 Option SW Version	0 N/A	All set-ups	FALSE	0	VisStr[20]
15-9* Parameter Info						
15-92	Defined Parameters	0 N/A	All set-ups	FALSE	0	Uint16
15-93	Modified Parameters	0 N/A	All set-ups	FALSE	0	Uint16
15-98	Unit Identification	0 N/A	All set-ups	FALSE	0	VisStr[40]
15-99	Parameter Metadata	0 N/A	All set-ups	FALSE	0	Uint16

Table 6.37

6.4.6 16-** Data Readouts

Par. No. #	Parameter description	Default value	4-set-up	Change during operation	Conversion index	Type
16-0* General Status						
16-00	Control Word	0 N/A	All set-ups	FALSE	0	V2
16-03	Status Word	0 N/A	All set-ups	FALSE	0	V2
16-3* AF Status						
16-30	DC Link Voltage	0 V	All set-ups	FALSE	0	Uint16
16-34	Heatsink Temp.	0 °C	All set-ups	FALSE	100	Uint8
16-35	Inverter Thermal	0 %	All set-ups	FALSE	0	Uint8
16-36	Inv. Nom. Current	ExpressionLimit	All set-ups	FALSE	-2	Uint32
16-37	Inv. Max. Current	ExpressionLimit	All set-ups	FALSE	-2	Uint32
16-39	Control Card Temp.	0 °C	All set-ups	FALSE	100	Uint8
16-40	Logging Buffer Full	[0] No	All set-ups	TRUE	-	Uint8
16-49	Current Fault Source	0 N/A	All set-ups	TRUE	0	Uint8
16-6* Inputs & Outputs						
16-60	Digital Input	0 N/A	All set-ups	FALSE	0	Uint16
16-66	Digital Output [bin]	0 N/A	All set-ups	FALSE	0	Int16
16-71	Relay Output [bin]	0 N/A	All set-ups	FALSE	0	Int16
16-8* Fieldbus & FC Port						
16-80	Fieldbus CTW 1	0 N/A	All set-ups	FALSE	0	V2
16-84	Comm. Option STW	0 N/A	All set-ups	FALSE	0	V2
16-85	FC Port CTW 1	0 N/A	All set-ups	FALSE	0	V2
16-9* Diagnosis Readouts						
16-90	Alarm Word	0 N/A	All set-ups	FALSE	0	Uint32
16-91	Alarm Word 2	0 N/A	All set-ups	FALSE	0	Uint32
16-92	Warning Word	0 N/A	All set-ups	FALSE	0	Uint32
16-93	Warning Word 2	0 N/A	All set-ups	FALSE	0	Uint32
16-94	Ext. Status Word	0 N/A	All set-ups	FALSE	0	Uint32

Table 6.38

6.4.7 300-** AF Settings

NOTE

Except for 300-10 Active Filter Nominal Voltage, it is not recommended to change the settings in this parameter group for the Low Harmonic Drive.

Par. No. #	Parameter description	Default value	4-set-up	Change during operation	Conversion index	Type
300-0* General Settings						
300-00	Harmonic Cancellation Mode	[0] Overall	All set-ups	TRUE	-	Uint8
300-01	Compensation Priority	[0] Harmonics	All set-ups	TRUE	-	Uint8
300-1* Network Settings						
300-10	Active Filter Nominal Voltage	ExpressionLimit	2 set-ups	FALSE	0	Uint32
300-2* CT Settings						
300-20	CT Primary Rating	ExpressionLimit	2 set-ups	FALSE	0	Uint32
300-22	CT Nominal Voltage	342 V	2 set-ups	FALSE	0	Uint32
300-24	CT Sequence	[0] L1, L2, L3	2 set-ups	FALSE	-	Uint8
300-25	CT Polarity	[0] Normal	2 set-ups	FALSE	-	Uint8
300-26	CT Placement	[1] Load Current	2 set-ups	FALSE	-	Uint8
300-29	Start Auto CT Detection	[0] Off	All set-ups	FALSE	-	Uint8
300-3* Compensation						
300-30	Compensation Points	0.0 A	All set-ups	TRUE	-1	Uint32
300-35	Cosphi Reference	0.500 N/A	All set-ups	TRUE	-3	Uint16
300-4* Paralleling						
300-40	Master Follower Selection	[2] Not Paralleled	2 set-ups	FALSE	-	Uint8
300-41	Follower ID	1 N/A	2 set-ups	FALSE	0	Uint32
300-42	Num. of Follower AFs	1 N/A	2 set-ups	FALSE	0	Uint32
300-5* Sleep Mode						
300-50	Enable Sleep Mode	null	2 set-ups	TRUE	-	Uint8
300-51	Sleep Mode Trig Source	[0] Mains current	All set-ups	TRUE	-	Uint8
300-52	Sleep Mode Wake Up Trigger	ExpressionLimit	All set-ups	TRUE	0	Uint32
300-53	Sleep Mode Sleep Trigger	80 %	All set-ups	TRUE	0	Uint32

Table 6.39

6.4.8 301-** AF Readouts

Par. No. #	Parameter description	Default value	4-set-up	Change during operation	Conversion index	Type
301-0* Output Currents						
301-00	Output Current [A]	0.00 A	All set-ups	TRUE	-2	Int32
301-01	Output Current [%]	0.0 %	All set-ups	TRUE	-1	Int32
301-1* Unit Performance						
301-10	THD of Current [%]	0.0 %	All set-ups	TRUE	-1	UInt16
301-11	Estimated THD of Voltage [%]	0.0 %	All set-ups			UInt16
301-12	Power Factor	0.00 N/A	All set-ups	TRUE	-2	UInt16
301-13	Cosphi	0.00 N/A	All set-ups	TRUE	-2	Int16
301-14	Leftover Currents	0.0 A	All set-ups	TRUE	-1	UInt32
301-2* Mains Status						
301-20	Mains Current [A]	0 A	All set-ups	TRUE	0	Int32
301-21	Mains Frequency	0 Hz	All set-ups	TRUE	0	UInt8
301-22	Fund. Mains Current [A]	0 A	All set-ups	TRUE	0	Int32

Table 6.40

7 RS-485 Installation and Set-up

7.1.1 Overview

RS-485 is a two-wire bus interface compatible with multi-drop network topology, i.e. nodes can be connected as a bus, or via drop cables from a common trunk line. A total of 32 nodes can be connected to one network segment. Repeaters divide network segments. Note that each repeater functions as a node within the segment in which it is installed. Each node connected within a given network must have a unique node address, across all segments. Terminate each segment at both ends, using either the termination switch (S801) of the frequency converters or a biased termination resistor network. Always use screened twisted pair (STP) cable for bus cabling, and always follow good common installation practice.

Low-impedance earth connection of the screen at every node is important, including at high frequencies. Thus, connect a large surface of the screen to earth, for example with a cable clamp or a conductive cable gland. It may be necessary to apply potential-equalizing cables to maintain the same earth potential throughout the network - particularly in installations with long cables.

To prevent impedance mismatch, always use the same type of cable throughout the entire network. When connecting a motor to the frequency converter, always use screened motor cable.

Cable:	Screened twisted pair (STP)
Impedance:	120 Ω
Cable length:	Max. 1200 m (including drop lines) Max. 500 m station-to-station

Table 7.1

7.1.2 Network Connection

One or more frequency converters can be connected to a control (or master) using the RS-485 standardized interface. Terminal 68 is connected to the P signal (TX+, RX+), while terminal 69 is connected to the N signal (TX-,RX-). See drawings in 4.8.1 *Electrical Installation, Control Cables*.

If more than one frequency converter is connected to a master, use parallel connections.

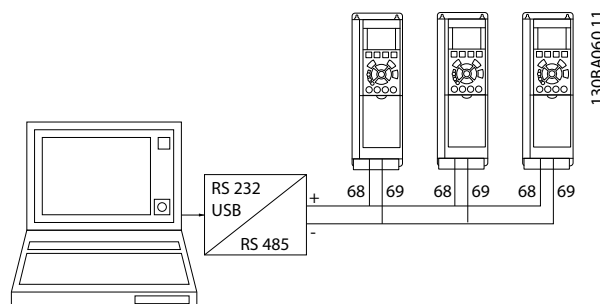

Illustration 7.1

In order to avoid potential equalizing currents in the screen, earth the cable screen via terminal 61, which is connected to the frame via an RC-link.

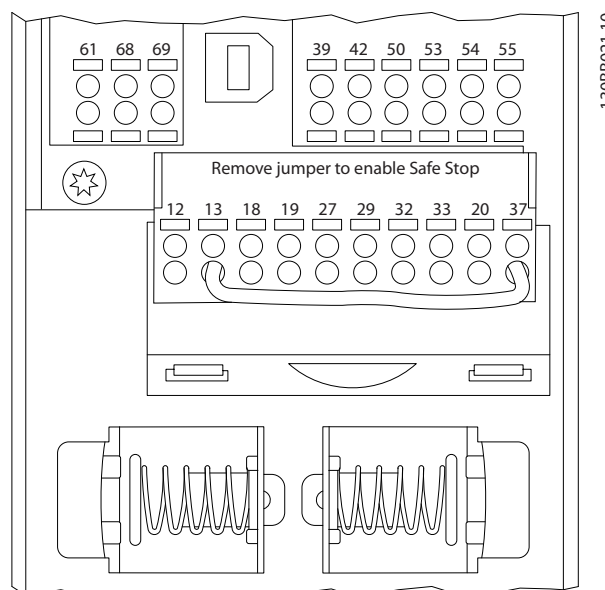

Illustration 7.2 Control Card Terminals

The RS-485 bus must be terminated by a resistor network at both ends. For this purpose, set switch S801 on the control card for "ON".

For more information, see 4.8.2 *Switches S201, S202, and S801*.

Communication protocol must be set to 8-30 Protocol.

7.1.3 EMC Precautions

The following EMC precautions are recommended in order to achieve interference-free operation of the RS-485 network.

Relevant national and local regulations, for example regarding protective earth connection, must be observed. The RS-485 communication cable must be kept away from motor and brake resistor cables to avoid coupling of high frequency noise from one cable to another. Normally a distance of 200 mm (8 inches) is sufficient, but keeping the greatest possible distance between the cables is generally recommended, especially where cables run in parallel over long distances. When crossing is unavoidable, the RS-485 cable must cross motor and brake resistor cables at an angle of 90°.

7

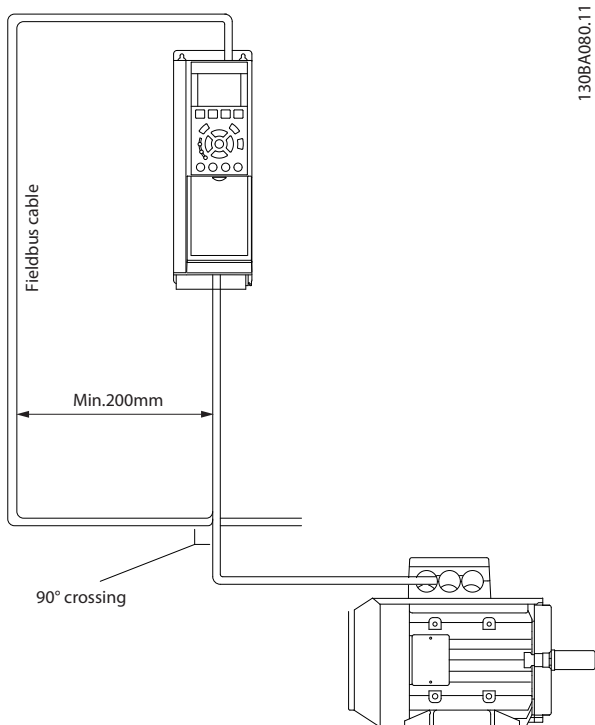

130BA080.11

Illustration 7.3

The FC protocol, also referred to as FC bus or Standard bus, is the Danfoss standard fieldbus. It defines an access technique according to the master-slave principle for communications via a serial bus.

One master and a maximum of 126 slaves can be connected to the bus. The master selects the individual slaves via an address character in the telegram. A slave itself can never transmit without first being requested to do so, and direct message transfer between the individual slaves is not possible. Communications occur in the half-duplex mode.

The master function cannot be transferred to another node (single-master system).

The physical layer is RS-485, thus utilizing the RS-485 port built into the frequency converter. The FC protocol supports different telegram formats:

- A short format of 8 bytes for process data.
- A long format of 16 bytes that also includes a parameter channel.
- A format used for texts.

7.2 Network Configuration

7.2.1 Frequency Converter Set-up

Set the following parameters to enable the FC protocol for the frequency converter.

Parameter Number	Setting
8-30 Protocol	FC
8-31 Address	1-126
8-32 FC Port Baud Rate	2400-115200
8-33 Parity / Stop Bits	Even parity, 1 stop bit (default)

Table 7.2

7.3 FC Protocol Message Framing Structure

7.3.1 Content of a Character (byte)

Each character transferred begins with a start bit. Then 8 data bits are transferred, corresponding to a byte. Each character is secured via a parity bit. This bit is set at "1" when it reaches parity. Parity is when there is an equal number of 1s in the 8 data bits and the parity bit in total. A stop bit completes a character, thus consisting of 11 bits in all.



195NA036.10

Illustration 7.4

7.3.2 Telegram Structure

Each telegram has the following structure:

1. Start character (STX)=02 Hex
2. A byte denoting the telegram length (LGE)

- 3. A byte denoting the frequency converter address (ADR)

A number of data bytes (variable, depending on the type of telegram) follows.

A data control byte (BCC) completes the telegram.

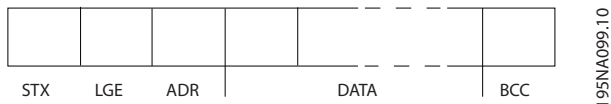

Illustration 7.5

7.3.3 Telegram Length (LGE)

The telegram length is the number of data bytes plus the address byte ADR and the data control byte BCC.

Data	Length
4 data bytes	LGE = 4 + 1 + 1 = 6 bytes
12 data bytes	LGE = 12 + 1 + 1 = 14 bytes
Telegrams containing texts	10 ¹⁾ +n bytes

Table 7.3

¹⁾ The 10 represents the fixed characters, while the "n" is variable (depending on the length of the text).

7.3.4 Frequency Converter Address (ADR)

Two different address formats are used. The address range of the frequency converter is either 1-31 or 1-126.

- 1. Address format 1-31:

- Bit 7 = 0 (address format 1-31 active)
- Bit 6 is not used

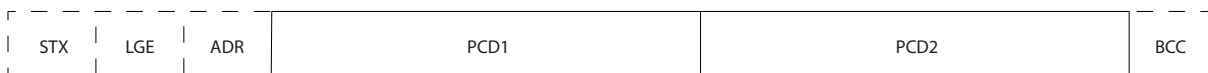

Illustration 7.6

Parameter block

The parameter block is used to transfer parameters between master and slave. The data block is made up of 12 bytes (6 words) and also contains the process block.

- Bit 5 = 1: Broadcast, address bits (0-4) are not used

- Bit 5 = 0: No Broadcast

- Bit 0-4 = frequency converter address 1-31

- 2. Address format 1-126:

- Bit 7 = 1 (address format 1-126 active)

- Bit 0-6 = frequency converter address 1-126

- Bit 0-6 = 0 Broadcast

The slave returns the address byte unchanged to the master in the response telegram.

7.3.5 Data Control Byte (BCC)

The checksum is calculated as an XOR-function. Before the first byte in the telegram is received, the Calculated Checksum is 0.

7.3.6 The Data Field

The structure of data blocks depends on the type of telegram. There are three telegram types, and the type applies for both control telegrams (master=>slave) and response telegrams (slave=>master).

The 3 types of telegram are:

Process block (PCD)

The PCD is made up of a data block of 4 bytes (2 words) and contains:

- Control word and reference value (from master to slave)
- Status word and present output frequency (from slave to master)

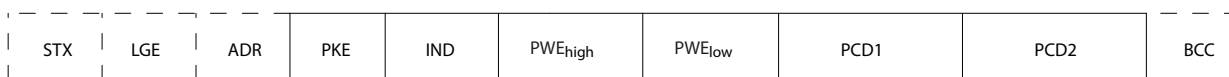

130BA271.10

Illustration 7.7

Text block

The text block is used to read or write texts via the data block.

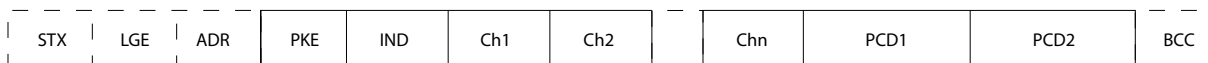

130BA270.10

Illustration 7.8

7

7.3.7 The PKE Field

The PKE field contains two sub-fields: Parameter command and response AK, and Parameter number PNU:

Bits no. 12-15 transfer parameter commands from master to slave and return processed slave responses to the master.

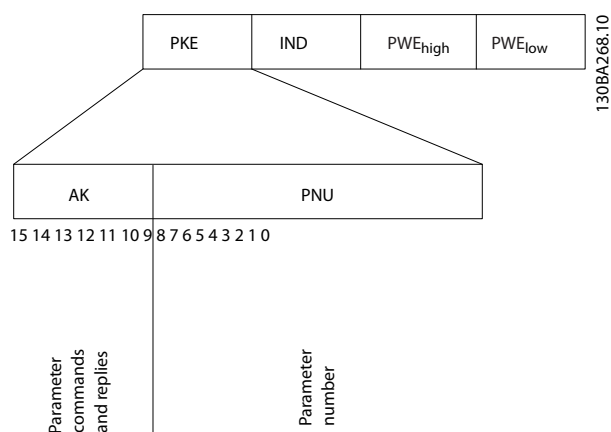

130BA268.10

Illustration 7.9

Bit no.				Parameter command
15	14	13	12	
0	0	0	0	No command
0	0	0	1	Read parameter value
0	0	1	0	Write parameter value in RAM (word)
0	0	1	1	Write parameter value in RAM (double word)
1	1	0	1	Write parameter value in RAM and EEPROM (double word)
1	1	1	0	Write parameter value in RAM and EEPROM (word)
1	1	1	1	Read/write text

Table 7.4 Parameter commands master ⇒ slave

Bit no.				Response
15	14	13	12	
0	0	0	0	No response
0	0	0	1	Parameter value transferred (word)
0	0	1	0	Parameter value transferred (double word)
0	1	1	1	Command cannot be performed
1	1	1	1	text transferred

Table 7.5 Response slave ⇒master

If the command cannot be performed, the slave sends this response:

0111 Command cannot be performed

- and issues the following fault report in the parameter value (PWE):

PWE low (Hex)	Fault Report
0	The parameter number used does not exist
1	There is no write access to the defined parameter
2	Data value exceeds the parameter's limits
3	The sub index used does not exist
4	The parameter is not the array type
5	The data type does not match the defined parameter
11	Data change in the defined parameter is not possible in the frequency converter's present mode. Certain parameters can only be changed when the motor is turned off
82	There is no bus access to the defined parameter
83	Data change is not possible because factory setup is selected

Table 7.6

7.3.8 Parameter Number (PNU)

Bits no. 0-11 transfer parameter numbers. The function of the relevant parameter is defined in the parameter description in the Programming Guide.

7.3.9 Index (IND)

The index is used together with the parameter number to read/write-access parameters with an index, e.g.

15-30 Alarm Log: Error Code. The index consists of 2 bytes, a low byte and a high byte.

Only the low byte is used as an index.

7.3.10 Parameter Value (PWE)

The parameter value block consists of 2 words (4 bytes), and the value depends on the defined command (AK). The master prompts for a parameter value when the PWE block contains no value. To change a parameter value (write), write the new value in the PWE block and send from the master to the slave.

When a slave responds to a parameter request (read command), the present parameter value in the PWE block is transferred and returned to the master. If a parameter

contains not a numerical value but several data options, e.g. *0-01 Language* where [0] corresponds to English, and [4] corresponds to Danish, select the data value by entering the value in the PWE block. See Example - Selecting a data value. Serial communication is only capable of reading parameters containing data type 9 (text string).

15-40 FC Type to 15-53 Power Card Serial Number contain data type 9.

For example, read the unit size and mains voltage range in *15-40 FC Type*. When a text string is transferred (read), the length of the telegram is variable, and the texts are of different lengths. The telegram length is defined in the second byte of the telegram, LGE. When using text transfer the index character indicates whether it is a read or a write command.

To read a text via the PWE block, set the parameter command (AK) to 'F' Hex. The index character high-byte must be "4".

Some parameters contain text that can be written to via the serial bus. To write a text via the PWE block, set the parameter command (AK) to 'F' Hex. The index characters high-byte must be "5".

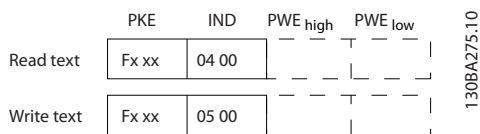

Illustration 7.10

7.3.11 Supported Data Types

Unsigned means that there is no operational sign in the telegram.

Data types	Description
3	Integer 16
4	Integer 32
5	Unsigned 8
6	Unsigned 16
7	Unsigned 32
9	Text string
10	Byte string
13	Time difference
33	Reserved
35	Bit sequence

Table 7.7

7.3.12 Conversion

The various attributes of each parameter are displayed in 6.3 Parameter Lists - Frequency Converter and 6.4 Parameter Lists - Active Filter. Parameter values are transferred as whole numbers only. Conversion factors are therefore used to transfer decimals.

4-12 Motor Speed Low Limit [Hz] has a conversion factor of 0.1.

To preset the minimum frequency to 10 Hz, transfer the value 100. A conversion factor of 0.1 means that the value transferred is multiplied by 0.1. The value 100 is thus perceived as 10.0.

Examples:

- 0s ⇒ conversion index 0
- 0.00s ⇒ conversion index -2
- 0ms ⇒ conversion index -3
- 0.00ms ⇒ conversion index -5

Conversion index	Conversion factor
100	
75	
74	
67	
6	1000000
5	100000

Conversion index	Conversion factor
4	10000
3	1000
2	100
1	10
0	1
-1	0.1
-2	0.01
-3	0.001
-4	0.0001
-5	0.00001
-6	0.000001
-7	0.0000001

Table 7.8 Conversion Table

7.3.13 Process Words (PCD)

The block of process words is divided into two blocks of 16 bits, which always occur in the defined sequence.

PCD 1	PCD 2
Control telegram (master ⇒ slave Control word)	Reference-value
Control telegram (slave ⇒ master) Status word	Present output frequency

Table 7.9

7.4 Examples

7.4.1 Writing a Parameter Value

Change 4-14 Motor Speed High Limit [Hz] to 100 Hz. Write the data in EEPROM.

- PKE = E19E Hex - Write single word in 4-14 Motor Speed High Limit [Hz]
- IND = 0000 Hex
- PWEHIGH = 0000 Hex
- PWELOW = 03E8 Hex - Data value 1000, corresponding to 100 Hz, see Conversion.

The telegram will look like this:

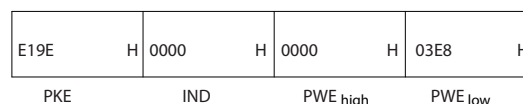

Illustration 7.11

NOTE

4-14 Motor Speed High Limit [Hz] is a single word, and the parameter command for write in EEPROM is "E". Parameter number 4-14 is 19E in hexadecimal.

The response from the slave to the master will be:

119E	H	0000	H	0000	H	03E8	H
PKE		IND		PWE _{high}		PWE _{low}	

130BA093.10

Illustration 7.12

7.4.2 Reading a Parameter Value

Read the value in 3-41 Ramp 1 Ramp Up Time

PKE = 1155 Hex - Read parameter value in 3-41 Ramp 1 Ramp Up Time
 IND = 0000 Hex
 PWEHIGH = 0000 Hex
 PWELOW = 0000 Hex

1155	H	0000	H	0000	H	0000	H
PKE		IND		PWE _{high}		PWE _{low}	

130BA094.10

Illustration 7.13

If the value in 3-41 Ramp 1 Ramp Up Time is 10 s, the response from the slave to the master will be:

1155	H	0000	H	0000	H	03E8	H
PKE		IND		PWE _{high}		PWE _{low}	

130BA267.10

Illustration 7.14

3E8 Hex corresponds to 1000 decimal. The conversion index for 3-41 Ramp 1 Ramp Up Time is -2, i.e. 0.01. 3-41 Ramp 1 Ramp Up Time is of the type *Unsigned 32*.

7.5 How to Access Parameters

7.5.1 Parameter Handling

The PNU (Parameter Number) is translated from the register address contained in the Modbus read or write message. The parameter number is translated to Modbus as (10 x parameter number) DECIMAL.

7.5.2 Storage of Data

The Coil 65 decimal determines whether data written to the frequency converter are stored in EEPROM and RAM (coil 65 = 1) or only in RAM (coil 65 = 0).

7.5.3 IND

The array index is set in Holding Register 9 and used when accessing array parameters.

7.5.4 Text Blocks

Parameters stored as text strings are accessed in the same way as the other parameters. The maximum text block size is 20 characters. If a read request for a parameter is for more characters than the parameter stores, the response is truncated. If the read request for a parameter is for fewer characters than the parameter stores, the response is space filled.

7.5.5 Conversion Factor

The different attributes for each parameter can be seen in the section on factory settings. Since a parameter value can only be transferred as a whole number, a conversion factor must be used to transfer decimals.

7.5.6 Parameter Values

Standard data types

Standard data types are int16, int32, uint8, uint16 and uint32. They are stored as 4x registers (40001 – 4FFFF). The parameters are read using function 03HEX "Read Holding Registers." Parameters are written using the function 6HEX "Preset Single Register" for 1 register (16 bits), and the function 10HEX "Preset Multiple Registers" for 2 registers (32 bits). Readable sizes range from 1 register (16 bits) up to 10 registers (20 characters).

Non standard data types

Non standard data types are text strings and are stored as 4x registers (40001 – 4FFFF). The parameters are read using function 03HEX "Read Holding Registers" and written using function 10HEX "Preset Multiple Registers." Readable sizes range from 1 register (2 characters) up to 10 registers (20 characters).

8 General Specifications

Mains supply (L1, L2, L3)

Supply voltage 380-480 V -10%, +5%

Mains voltage low/mains drop-out:

During low mains voltage or a mains drop-out, the frequency converter continues until the intermediate circuit voltage drops below the minimum stop level, which corresponds typically to 15% below the frequency converter's lowest rated supply voltage. Power-up and full torque cannot be expected at mains voltage lower than 10% below the frequency converter's lowest rated supply voltage.

Supply frequency 50/60 Hz \pm 5%

Max. imbalance temporary between mains phases 3.0 % of rated supply voltage

True Power Factor (λ) >0.98 nominal at rated load

Displacement Power Factor ($\cos\phi$) near unity (>0.98)

THiD $< 5\%$

Switching on input supply L1, L2, L3 (power-ups) maximum once/2 min.

Environment according to EN60664-1 overvoltage category III/pollution degree 2

The unit is suitable for use on a circuit capable of delivering not more than 100.000 RMS symmetrical Amperes, 480/690 V maximum.

Motor output (U, V, W)

Output voltage 0-100% of supply voltage

Output frequency 0-800* Hz

Switching on output Unlimited

Ramp times 1-3600 s

* Voltage and power dependent

Torque characteristics

Starting torque (Constant torque) maximum 110% for 1 min.*

Starting torque maximum 135% up to 0.5 s*

Overload torque (Constant torque) maximum 110% for 1 min.*

**Percentage relates to the frequency converter's nominal torque.*

Cable lengths and cross sections

Max. motor cable length, screened/armoured 150 m

Max. motor cable length, unscreened/unarmoured 300 m

Max. cross section to motor, mains, load sharing and brake *

Maximum cross section to control terminals, rigid wire 1.5 mm²/16 AWG (2x0.75 mm²)

Maximum cross section to control terminals, flexible cable 1 mm²/18 AWG

Maximum cross section to control terminals, cable with enclosed core 0.5 mm²/20 AWG

Minimum cross section to control terminals 0.25 mm²

** See Table 8.1, Table 8.2 and Table 8.3 for more information!*

Digital inputs

Programmable digital inputs 4 (6)

Terminal number 18, 19, 27 ¹⁾, 29 ¹⁾, 32, 33,

Logic PNP or NPN

Voltage level 0-24 V DC

Voltage level, logic '0' PNP <5 V DC

Voltage level, logic '1' PNP >10 V DC

Voltage level, logic '0' NPN >19 V DC

Voltage level, logic '1' NPN <14 V DC

Maximum voltage on input 28 V DC

Input resistance, R_i approx. 4 k Ω

All digital inputs are galvanically isolated from the supply voltage (PELV) and other high-voltage terminals.

1) Terminals 27 and 29 can also be programmed as output.

Analog inputs	
Number of analog inputs	2
Terminal number	53, 54
Modes	Voltage or current
Mode select	Switch S201 and switch S202
Voltage mode	Switch S201/switch S202 = OFF (U)
Voltage level	0 to + 10 V (scaleable)
Input resistance, R_i	approx. 10 k Ω
Max. voltage	\pm 20 V
Current mode	Switch S201/switch S202 = ON (I)
Current level	0/4 to 20 mA (scaleable)
Input resistance, R_i	approx. 200 Ω
Max. current	30 mA
Resolution for analog inputs	10 bit (+ sign)
Accuracy of analog inputs	Max. error 0.5% of full scale
Bandwidth	200 Hz

The analog inputs are galvanically isolated from the supply voltage (PELV) and other high-voltage terminals.

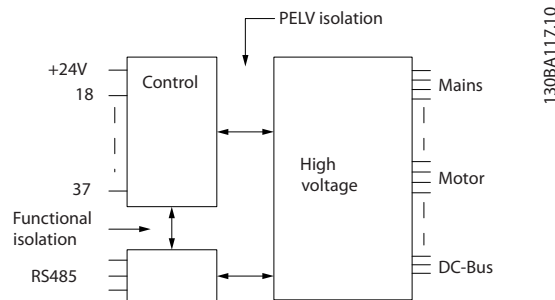

Illustration 8.1

Pulse inputs	
Programmable pulse inputs	2
Terminal number pulse	29, 33
Max. frequency at terminal, 29, 33	110 kHz (Push-pull driven)
Max. frequency at terminal, 29, 33	5 kHz (open collector)
Min. frequency at terminal 29, 33	4 Hz
Voltage level	see 8.1.1 Digital Inputs
Maximum voltage on input	28 V DC
Input resistance, R_i	approx. 4k Ω
Pulse input accuracy (0.1-1 kHz)	Max. error: 0.1% of full scale
Analog output	
Number of programmable analog outputs	1
Terminal number	42
Current range at analog output	0/4-20 mA
Max. resistor load to common at analog output	500 Ω
Accuracy on analog output	Max. error: 0.8% of full scale
Resolution on analog output	8 bit

The analog output is galvanically isolated from the supply voltage (PELV) and other high-voltage terminals.

Control card, RS-485 serial communication	
Terminal number	68 (P,TX+, RX+), 69 (N,TX-, RX-)
Terminal number 61	Common for terminals 68 and 69

The RS-485 serial communication circuit is functionally seated from other central circuits and galvanically isolated from the supply voltage (PELV).

Digital output	
Programmable digital/pulse outputs	2
Terminal number	27, 29 ¹⁾
Voltage level at digital/frequency output	0-24 V
Max. output current (sink or source)	40 mA
Max. load at frequency output	1 kΩ
Max. capacitive load at frequency output	10 nF
Minimum output frequency at frequency output	0 Hz
Maximum output frequency at frequency output	32 kHz
Accuracy of frequency output	Max. error: 0.1% of full scale
Resolution of frequency outputs	12 bit

1) Terminal 27 and 29 can also be programmed as input.

The digital output is galvanically isolated from the supply voltage (PELV) and other high-voltage terminals.

Control card, 24 V DC output

Terminal number	12, 13
Max. load	200 mA

The 24 V DC supply is galvanically isolated from the supply voltage (PELV), but has the same potential as the analog and digital inputs and outputs.

Relay outputs

Programmable relay outputs		2
Relay 01 Terminal number		1-3 (break), 1-2 (make)
Max. terminal load (AC-1) ¹⁾ on 1-3 (NC), 1-2 (NO) (Resistive load)		240 V AC, 2 A
Max. terminal load (AC-15) ¹⁾ (Inductive load @ cosφ 0.4)		240 V AC, 0.2 A
Max. terminal load (DC-1) ¹⁾ on 1-2 (NO), 1-3 (NC) (Resistive load)		60 V DC, 1 A
Max. terminal load (DC-13) ¹⁾ (Inductive load)		24 V DC, 0.1 A
Relay 02 Terminal number		4-6 (break), 4-5 (make)
Max. terminal load (AC-1) ¹⁾ on 4-5 (NO) (Resistive load) ²⁾³⁾		400 V AC, 2 A
Max. terminal load (AC-15) ¹⁾ on 4-5 (NO) (Inductive load @ cosφ 0.4)		240 V AC, 0.2 A
Max. terminal load (DC-1) ¹⁾ on 4-5 (NO) (Resistive load)		80 V DC, 2 A
Max. terminal load (DC-13) ¹⁾ on 4-5 (NO) (Inductive load)		24 V DC, 0.1 A
Max. terminal load (AC-1) ¹⁾ on 4-6 (NC) (Resistive load)		240 V AC, 2 A
Max. terminal load (AC-15) ¹⁾ on 4-6 (NC) (Inductive load @ cosφ 0.4)		240 V AC, 0.2 A
Max. terminal load (DC-1) ¹⁾ on 4-6 (NC) (Resistive load)		50 V DC, 2 A
Max. terminal load (DC-13) ¹⁾ on 4-6 (NC) (Inductive load)		24 V DC, 0.1 A
Min. terminal load on 1-3 (NC), 1-2 (NO), 4-6 (NC), 4-5 (NO)		24 V DC 10 mA, 24 V AC 20 mA
Environment according to EN 60664-1		overvoltage category III/pollution degree 2

1) IEC 60947 parts 4 and 5

The relay contacts are galvanically isolated from the rest of the circuit by reinforced isolation (PELV).

2) Overvoltage Category II

3) UL applications 300 V AC 2 A

Control card, 10 V DC output

Terminal number	50
Output voltage	10.5 V ±0.5 V
Max. load	25 mA

The 10 V DC supply is galvanically isolated from the supply voltage (PELV) and other high-voltage terminals.

Control characteristics

Resolution of output frequency at 0-1000 Hz	±0.003 Hz
System response time (terminals 18, 19, 27, 29, 32, 33)	≤ 2 ms
Speed control range (open loop)	1:100 of synchronous speed
Speed accuracy (open loop)	30-4000 rpm: Maximum error of ±8 rpm

All control characteristics are based on a 4-pole asynchronous motor

Surroundings

Enclosure, frame size D and E	IP21, IP54 (hybrid)
Enclosure, frame size F	IP21, IP54 (hybrid)
Vibration test	0.7 g
Relative humidity	5%-95% (IEC 721-3-3; Class 3K3 (non-condensing) during operation
Aggressive environment (IEC 60068-2-43) H ₂ S test	class kD
Test method according to IEC 60068-2-43 H ₂ S (10 days)	
Ambient temperature (at 60 AVM switching mode)	
- with derating	max. 55 °C ¹⁾
- with full output power, typical EFF2 motors	max. 50 °C ¹⁾
- at full continuous frequency converter output current	max. 45 °C ¹⁾

¹⁾ For more information on derating see the Design Guide, section on Special Conditions.

Minimum ambient temperature during full-scale operation	0 °C
Minimum ambient temperature at reduced performance	- 10 °C
Temperature during storage/transport	-25 to +65/70 °C
Maximum altitude above sea level without derating	1000 m
Maximum altitude above sea level with derating	3000 m

Derating for high altitude, see section on special conditions in the Design Guide.

EMC standards, Emission	EN 61800-3, EN 61000-6-3/4, EN 55011, IEC 61800-3 EN 61800-3, EN 61000-6-1/2,
EMC standards, Immunity	EN 61000-4-2, EN 61000-4-3, EN 61000-4-4, EN 61000-4-5, EN 61000-4-6

See section on special conditions in the Design Guide.

Control card performance

Scan interval	5 ms
Control card, USB serial communication	
USB standard	1.1 (Full speed)
USB plug	USB type B "device" plug

CAUTION

Connection to PC is carried out via a standard host/device USB cable.

The USB connection is galvanically isolated from the supply voltage (PELV) and other high-voltage terminals.

The USB connection is **not** galvanically isolated from protection earth. Use only isolated laptop/PC as connection to the USB connector on the frequency converter or an isolated USB cable/converter.

Protection and Features

- Electronic thermal motor protection against overload.
- Temperature monitoring of the heatsink ensures that the frequency converter trips if the temperature reaches a predefined level. An overload temperature cannot be reset until the temperature of the heatsink is below the values stated in the tables on the following pages (Guideline - these temperatures may vary for different power sizes, frame sizes, enclosure ratings etc.).
- The frequency converter is protected against short-circuits on motor terminals U, V, W.
- If a mains phase is missing, the frequency converter trips or issues a warning (depending on the load).
- Monitoring of the intermediate circuit voltage ensures that the frequency converter trips if the intermediate circuit voltage is too low or too high.
- The frequency converter is protected against earth faults on motor terminals U, V, W.



		P160	P200	P250
	Typical Shaft output at 400 V [kW]	160	200	250
	Typical Shaft output at 460 V [HP]	250	300	350
	Enclosure IP21	D13	D13	D13
	Enclosure IP54	D13	D13	D13
	Output current			
	Continuous (at 400 V) [A]	315	395	480
	Intermittent (60 s overload) (at 400 V) [A]	347	435	528
	Continuous (at 460/480 V) [A]	302	361	443
	Intermittent (60 s overload) (at 460/480 V) [A]	332	397	487
	Continuous KVA (at 400 V) [KVA]	218	274	333
	Continuous KVA (at 460 V) [KVA]	241	288	353
Max. input current				
	Continuous (at 400 V) [A]	304	381	463
	Continuous (at 460/480 V) [A]	291	348	427
	Max. cable size, mains motor, brake and load share [mm ² (AWG ²)]	2x185 (2x300 mcm)	2x185 (2x300 mcm)	2x185 (2x300 mcm)
	Max. external pre-fuses [A] ¹	400	500	630
	Estimated motor power loss at rated max. load [W] ⁴ , 400 V	4029	5130	5621
	Estimated motor power loss at rated max. load [W] ⁴ , 460 V	3892	4646	5126
	Estimated filter losses, 400 V	4954	5714	6234
	Estimated filter losses, 460 V	5279	5819	6681
	Weight, enclosure IP21, IP54 [kg]	390	390	406
	Efficiency ⁴⁾	0.96		
	Output frequency	0-800 Hz		
	Heatsink overtemp. trip	110 °C	110 °C	110 °C
	Power card ambient trip	60 °C		

Table 8.1 Mains Supply 3x380-480 V AC

		P315	P355	P400	P450
	Typical Shaft output at 400 V [kW]	315	355	400	450
	Typical Shaft output at 460 V [HP]	450	500	600	600
	Enclosure IP21	E9	E9	E9	E9
	Enclosure IP54	E9	E9	E9	E9
	Output current				
	Continuous (at 400 V) [A]	600	658	745	800
	Intermittent (60 s overload) (at 400 V) [A]	660	724	820	880
	Continuous (at 460/480 V) [A]	540	590	678	730
	Intermittent (60 s overload) (at 460/480 V) [A]	594	649	746	803
	Continuous KVA (at 400 V) [KVA]	416	456	516	554
	Continuous KVA (at 460 V) [KVA]	430	470	540	582
	Max. input current				
	Continuous (at 400 V) [A]	590	647	733	787
	Continuous (at 460/480 V) [A]	531	580	667	718
	Max. cable size, mains, motor and load share [mm ² (AWG ²)]	4x240 (4x500 mcm)	4x240 (4x500 mcm)	4x240 (4x500 mcm)	4x240 (4x500 mcm)
	Max. cable size, brake [mm ² (AWG ²)]	2x185 (2x350 mcm)	2x185 (2x350 mcm)	2x185 (2x350 mcm)	2x185 (2x350 mcm)
	Max. external pre-fuses [A] ¹	700	900	900	900
	Estimated motor power loss at rated max. load [W] ⁴ , 400 V	6704	7528	8671	9469
	Estimated motor power loss at rated max. load [W] ⁴ , 460 V	5930	6724	7820	8527
	Estimated filter losses, 400 V	6607	7049	7725	8234
	Estimated filter losses, 460 V	6670	7023	7697	8099
	Weight, enclosure IP21, IP54 [kg]	676			
	Efficiency ⁴	0.96			
	Output frequency	0-600 Hz			
	Heatsink overtemp. trip	110 °C			
	Power card ambient trip	68 °C			

Table 8.2 Mains Supply 3x380-480 V AC

		P500	P560	P630	P710
	Typical Shaft output at 400 V [kW]	500	560	630	710
	Typical Shaft output at 460 V [HP]	650	750	900	1000
	Enclosure IP21, IP54	F18	F18	F18	F18
	Output current				
	Continuous (at 400 V) [A]	880	990	1120	1260
	Intermittent (60 s overload) (at 400 V) [A]	968	1089	1232	1386
	Continuous (at 460/80 V) [A]	780	890	1050	1160
	Intermittent (60 s overload) (at 460/80 V) [A]	858	979	1155	1276
	Continuous KVA (at 400 V) [KVA]	610	686	776	873
	Continuous KVA (at 460 V) [KVA]	621	709	837	924
Max. input current					
	Continuous (at 400 V) [A]	857	964	1090	1227
	Continuous (at 460/80 V) [A]	759	867	1022	1129
	Max. cable size, motor [mm ² (AWG ²)]	8x150 (8x300 mcm)			
	Max. cable size, mains F1/F2 [mm ² (AWG ²)]	8x240 (8x500 mcm)			
	Max. cable size, mains F3/F4 [mm ² (AWG ²)]	8x456 (8x900 mcm)			
	Max. cable size, loadsharing [mm ² (AWG ²)]	4x120 (4x250 mcm)			
Max. cable size, brake [mm ² (AWG ²)]	4x185 (4x350 mcm)				
Max. external pre-fuses [A] ¹	1600		2000		
Est. motor power loss at rated max. load [W] ⁴⁾ 400 V, F1 & F2	10647	12338	13201	15436	
Est. motor power loss at rated max. load [W] ⁴⁾ 460 V, F1 & F2	9414	11006	12353	14041	
Max added losses of A1 RFI, Circuit Breaker or Disconnect, & Contactor, F3 & F4	963	1054	1093	1230	
Max Panel Options Losses	400				
Weight, enclosure IP21, IP54 [kg]	1900				
Weight Drive section [kg]	1004				
Weight Filter section [kg]	896				
Efficiency ⁴⁾	0.96				
Output frequency	0-600 Hz				
Heatsink overtemp. trip	95 °C				
Power card ambient trip	68 °C				

Table 8.3 Mains Supply 3x380-480 V AC

- 1) For type of fuse see 4.6.14 Fuses.
- 2) American Wire Gauge.

3) Measured using 5 m screened motor cables at rated load and rated frequency.

4) The typical power loss is at nominal load conditions and expected to be within $\pm 15\%$ (tolerance relates to variety in voltage and cable conditions). Values are based on a typical motor efficiency (eff2/eff3 border line). Motors with lower efficiency will also add to the power loss in the frequency converter and opposite. If the switching frequency is increased from the default setting, the power losses may rise significantly. LCP and typical control card power consumptions are included. Further options and customer load may add up to 30 W to the losses. (Though typical only 4 W extra for a fully loaded control card, or options for slot A or slot B, each). Although measurements are made with state of the art equipment, some measurement inaccuracy must be allowed for ($\pm 5\%$).

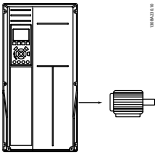
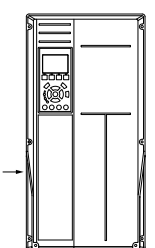
8.1 Filter Specifications

Frame size	D	E	F	
Voltage [V]	380-480	380-480	380-480	
Current, RMS [A]	120	210	330	Nominal value
Peak Current [A]	340	595	935	Amplitude value of the current
RMS overload [%]	No Overload			60 s in 10 min
Response time [ms]	<0.5			
Settling time-reactive current control [ms]	<40			
Settling time-harmonic current control (filtering) [ms]	<20			
Overshoot-reactive current control [%]	<20			
Overshoot-harmonic current control [%]	<10			

Table 8.4 Power Ranges (LHD with AF)

9 Troubleshooting

9.1 Alarms and Warnings - Frequency Converter (right LCP)

A warning or an alarm is signalled by the relevant LED on the front of the frequency converter and indicated by a code on the display.

A warning remains active until its cause is no longer present. Under certain circumstances operation of the motor may still be continued. Warning messages may be critical, but are not necessarily so.

In the event of an alarm, the frequency converter will have tripped. Alarms must be reset to restart operation once their cause has been rectified.

This may be done in four ways:

1. Pressing [Reset] on the LCP.
2. Via a digital input with the "Reset" function.
3. Via serial communication/optional fieldbus.
4. By resetting automatically using the [Auto Reset] function, which is a default setting for VLT HVAC Drive Drive, see *14-20 Reset Mode* in the FC 100 Programming Guide.

NOTE

After a manual reset pressing [Reset], the [Auto On] or [Hand On] must be pressed to restart the motor.

If an alarm cannot be reset, the reason may be that its cause has not been rectified, or the alarm is trip-locked (see also *Table 9.1*).

CAUTION

Alarms that are trip-locked offer additional protection, means that the mains supply must be switched off before the alarm can be reset. After being switched back on, the frequency converter is no longer blocked and may be reset as described above once the cause has been rectified.

Alarms that are not trip-locked can also be reset using the automatic reset function in *14-20 Reset Mode* (Warning: automatic wake-up is possible!)

If a warning and alarm is marked against a code in the table on the following page, this means that either a warning occurs before an alarm, or it can be specified whether it is a warning or an alarm that is to be displayed for a given fault.

This is possible, for instance, in *1-90 Motor Thermal Protection*. After an alarm or trip, the motor carries on coasting, and the alarm and warning flash on the frequency converter. Once the problem has been rectified, only the alarm continues flashing.

No.	Description	Warning	Alarm/ Trip	Alarm/Trip Lock	Parameter Reference
1	10 Volts low	X			
2	Live zero error	(X)	(X)		6-01
3	No motor	(X)			1-80
4	Mains phase loss	(X)	(X)	(X)	14-12
5	DC link voltage high	X			
6	DC link voltage low	X			
7	DC over voltage	X	X		
8	DC under voltage	X	X		
9	Inverter overloaded	X	X		
10	Motor ETR over temperature	(X)	(X)		1-90
11	Motor thermistor over temperature	(X)	(X)		1-90
12	Torque limit	X	X		
13	Over Current	X	X	X	
14	Earth fault	X	X	X	
15	Hardware mismatch		X	X	
16	Short Circuit		X	X	
17	Control word timeout	(X)	(X)		8-04
23	Internal Fan Fault	X			

No.	Description	Warning	Alarm/ Trip	Alarm/Trip Lock	Parameter Reference
24	External Fan Fault	X			14-53
25	Brake resistor short-circuited	X			
26	Brake resistor power limit	(X)	(X)		2-13
27	Brake chopper short-circuited	X	X		
28	Brake check	(X)	(X)		2-15
29	Drive over temperature	X	X	X	
30	Motor phase U missing	(X)	(X)	(X)	4-58
31	Motor phase V missing	(X)	(X)	(X)	4-58
32	Motor phase W missing	(X)	(X)	(X)	4-58
33	Inrush fault		X	X	
34	Fieldbus communication fault	X	X		
35	Out of frequency range	X	X		
36	Mains failure	X	X		
37	Phase Imbalance	X	X		
38	Internal fault		X	X	
39	Heatsink sensor		X	X	
40	Overload of Digital Output Terminal 27	(X)			5-00, 5-01
41	Overload of Digital Output Terminal 29	(X)			5-00, 5-02
42	Overload of Digital Output On X30/6	(X)			5-32
42	Overload of Digital Output On X30/7	(X)			5-33
46	Pwr. card supply		X	X	
47	24 V supply low	X	X	X	
48	1.8 V supply low		X	X	
49	Speed limit	X	(X)		1-86
50	AMA calibration failed		X		
51	AMA check U_{nom} and I_{nom}		X		
52	AMA low I_{nom}		X		
53	AMA motor too big		X		
54	AMA motor too small		X		
55	AMA Parameter out of range		X		
56	AMA interrupted by user		X		
57	AMA timeout		X		
58	AMA internal fault	X	X		
59	Current limit	X			
60	External Interlock	X			
62	Output Frequency at Maximum Limit	X			
64	Voltage Limit	X			
65	Control Board Over-temperature	X	X	X	
66	Heat sink Temperature Low	X			
67	Option Configuration has Changed		X		
69	Pwr. Card Temp		X	X	
70	Illegal FC configuration			X	
71	PTC 1 Safe Stop	X	X ¹⁾		
72	Dangerous Failure			X ¹⁾	
73	Safe Stop Auto Restart				
76	Power Unit Setup	X			
79	Illegal PS config		X	X	
80	Drive Initialized to Default Value		X		
91	Analog input 54 wrong settings			X	
92	NoFlow	X	X		22-2*
93	Dry Pump	X	X		22-2*
94	End of Curve	X	X		22-5*

No.	Description	Warning	Alarm/ Trip	Alarm/Trip Lock	Parameter Reference
95	Broken Belt	X	X		22-6*
96	Start Delayed	X			22-7*
97	Stop Delayed	X			22-7*
98	Clock Fault	X			0-7*
201	Fire M was Active				
202	Fire M Limits Exceeded				
203	Missing Motor				
204	Locked Rotor				
243	Brake IGBT	X	X		
244	Heatsink temp	X	X	X	
245	Heatsink sensor		X	X	
246	Pwr.card supply		X	X	
247	Pwr.card temp		X	X	
248	Illegal PS config		X	X	
250	New spare parts			X	
251	New Type Code		X	X	

Table 9.1 Alarm/Warning Code List

(X) Dependent on parameter

1) Can not be Auto reset via 14-20 Reset Mode

A trip is the action when an alarm has appeared. The trip will coast the motor and can be reset by pressing [Reset] or make a reset by a digital input (parameter group 5-1* [1]). The original event that caused an alarm cannot damage the frequency converter or cause dangerous conditions. A trip lock is an action when an alarm occurs,

which may cause damage to frequency converter or connected parts. A Trip Lock situation can only be reset by a power cycling.

Warning	yellow
Alarm	flashing red
Trip locked	yellow and red

Table 9.2 LED Indication

Alarm Word and Extended Status Word					
Bit	Hex	Dec	Alarm Word	Warning Word	Extended Status Word
0	00000001	1	Brake Check	Brake Check	Ramping
1	00000002	2	Pwr. Card Temp	Pwr. Card Temp	AMA Running
2	00000004	4	Earth Fault	Earth Fault	Start CW/CCW
3	00000008	8	Ctrl.Card Temp	Ctrl.Card Temp	Slow Down
4	00000010	16	Ctrl. Word TO	Ctrl. Word TO	Catch Up
5	00000020	32	Over Current	Over Current	Feedback High
6	00000040	64	Torque Limit	Torque Limit	Feedback Low
7	00000080	128	Motor Th Over	Motor Th Over	Output Current High
8	00000100	256	Motor ETR Over	Motor ETR Over	Output Current Low
9	00000200	512	Inverter Overld.	Inverter Overld.	Output Freq High
10	00000400	1024	DC under Volt	DC under Volt	Output Freq Low
11	00000800	2048	DC over Volt	DC over Volt	Brake Check OK
12	00001000	4096	Short Circuit	DC Voltage Low	Braking Max
13	00002000	8192	Inrush Fault	DC Voltage High	Braking
14	00004000	16384	Mains ph. Loss	Mains ph. Loss	Out of Speed Range
15	00008000	32768	AMA Not OK	No Motor	OVC Active
16	00010000	65536	Live Zero Error	Live Zero Error	
17	00020000	131072	Internal Fault	10V Low	
18	00040000	262144	Brake Overload	Brake Overload	
19	00080000	524288	U phase Loss	Brake Resistor	
20	00100000	1048576	V phase Loss	Brake IGBT	
21	00200000	2097152	W phase Loss	Speed Limit	
22	00400000	4194304	Fieldbus Fault	Fieldbus Fault	
23	00800000	8388608	24V Supply Low	24V Supply Low	
24	01000000	16777216	Mains Failure	Mains Failure	
25	02000000	33554432	1.8V Supply Low	Current Limit	
26	04000000	67108864	Brake Resistor	Low Temp	
27	08000000	134217728	Brake IGBT	Voltage Limit	
28	10000000	268435456	Option Change	Unused	
29	20000000	536870912	Drive Initialized	Unused	
30	40000000	1073741824	Safe Stop	Unused	

Table 9.3 Description of Alarm Word, Warning Word and Extended Status Word

The alarm words, warning words and extended status words can be read out via serial bus or optional fieldbus for diagnosis. See also *16-90 Alarm Word*, *16-92 Warning Word* and *16-94 Ext. Status Word*.

9.1.1 Fault Messages

WARNING 1, 10 Volts low

The control card voltage is below 10 V from terminal 50. Remove some of the load from terminal 50, as the 10 V supply is overloaded. Max. 15 mA or minimum 590 Ω .

This condition can be caused by a short in a connected potentiometer or improper wiring of the potentiometer.

Troubleshooting: Remove the wiring from terminal 50. If the warning clears, the problem is with the customer wiring. If the warning does not clear, replace the control card.

WARNING/ALARM 2, Live zero error

This warning or alarm will only appear if programmed by the user in *6-01 Live Zero Timeout Function*. The signal on one of the analog inputs is less than 50% of the minimum value programmed for that input. This condition can be caused by broken wiring or faulty device sending the signal.

Troubleshooting:

Check connections on all the analog input terminals. Control card terminals 53 and 54 for signals, terminal 55 common. MCB 101 terminals 11 and 12 for signals, terminal 10 common. MCB 109 terminals 1, 3, 5 for signals, terminals 2, 4, 6 common).

Check that the frequency converter programming and switch settings match the analog signal type.

Perform Input Terminal Signal Test.

WARNING/ALARM 3, No motor

No motor has been connected to the output of the frequency converter. This warning or alarm will only appear if programmed by the user in *1-80 Function at Stop*.

Troubleshooting: Check the connection between the frequency converter and the motor.

WARNING/ALARM 4, Mains phase loss A phase is missing on the supply side, or the mains voltage imbalance is too high. This message also appears for a fault in the input rectifier on the frequency converter. Options are programmed at *14-12 Function at Mains Imbalance*.

Troubleshooting: Check the supply voltage and supply currents to the frequency converter.

WARNING 5, DC link voltage high

The intermediate circuit voltage (DC) is higher than the high voltage warning limit. The limit is dependent on the frequency converter voltage rating. The frequency converter is still active.

WARNING 6, DC link voltage low

The intermediate circuit voltage (DC) is lower than the low voltage warning limit. The limit is dependent on the frequency converter voltage rating. The frequency converter is still active.

WARNING/ALARM 7, DC overvoltage

If the intermediate circuit voltage exceeds the limit, the frequency converter trips after a time.

Troubleshooting:

Connect a brake resistor

Extend the ramp time

Change the ramp type

Activate functions in *2-10 Brake Function*

Increase *14-26 Trip Delay at Inverter Fault*

WARNING/ALARM 8, DC under voltage

If the intermediate circuit voltage (DC) drops below the under voltage limit, the frequency converter checks if a 24 V backup supply is connected. If no 24 V backup supply is connected, the frequency converter trips after a fixed time delay. The time delay varies with unit size.

Troubleshooting:

Check that the supply voltage matches the frequency converter voltage.

Perform Input voltage test

Perform soft charge and rectifier circuit test

WARNING/ALARM 9, Inverter overloaded

The frequency converter is about to cut out because of an overload (too high current for too long). The counter for electronic, thermal inverter protection gives a warning at 98% and trips at 100%, while giving an alarm. The frequency converter *cannot* be reset until the counter is below 90%.

The fault is that the frequency converter is overloaded by more than 100% for too long.

Troubleshooting:

Come the output current shown on the LCP with the drive rated current.

Come the output current shown on the LCP with measured motor current.

Display the Thermal Drive Load on the keypad and monitor the value. When running above the drive continuous current rating, the counter should increase. When running below the drive continuous current rating, the counter should decrease.

NOTE

See the derating section in the Design Guide for more details if a high switching frequency is required.

WARNING/ALARM 10, Motor overload temperature

According to the electronic thermal protection (ETR), the motor is too hot. Select whether the frequency converter gives a warning or an alarm when the counter reaches 100% in *1-90 Motor Thermal Protection*. The fault is that the motor is overloaded by more than 100% for too long.

Troubleshooting:

- Check if motor is over heating.
- If the motor is mechanically overloaded
- That the motor *1-24 Motor Current* is set correctly.
- Motor data in parameters 1-20 through 1-25 are set correctly.
- The setting in *1-91 Motor External Fan*.
- Run AMA in *1-29 Automatic Motor Adaptation (AMA)*.

WARNING/ALARM 11, Motor thermistor over temp

The thermistor or the thermistor connection is disconnected. Select whether the frequency converter gives a warning or an alarm when the counter reaches 100% in *1-90 Motor Thermal Protection*.

Troubleshooting:

- Check if motor is over heating.
- Check if the motor is mechanically overloaded.
- Check that the thermistor is connected correctly between terminal 53 or 54 (analog voltage input) and terminal 50 (+10 V supply), or between terminal 18 or 19 (digital input PNP only) and terminal 50.
- If a KTY sensor is used, check for correct connection between terminal 54 and 55.
- If using a thermal switch or thermistor, check the programming of *1-93 Thermistor Source* matches sensor wiring.
- If using a KTY sensor, check the programming of parameters 1-95, 1-96, and 1-97 match sensor wiring.

WARNING/ALARM 12, Torque limit

The torque is higher than the value in *4-16 Torque Limit Motor Mode* or the torque is higher than the value in *4-17 Torque Limit Generator Mode*. *14-25 Trip Delay at Torque Limit* can be used to change this from a warning only condition to a warning followed by an alarm.

WARNING/ALARM 13, Over current

The inverter peak current limit (approx. 200% of the rated current) is exceeded. The warning lasts about 1.5 sec., then the frequency converter trips and issues an alarm. If extended mechanical brake control is selected, trip can be reset externally.

Troubleshooting:

- This fault may be caused by shock loading or fast acceleration with high inertia loads.
- Turn off the frequency converter. Check if the motor shaft can be turned.
- Check that the motor size matches the frequency converter.
- Incorrect motor data in parameters 1-20 through 1-25.

ALARM 14, Earth (ground) fault

There is a discharge from the output phases to earth, either in the cable between the frequency converter and the motor or in the motor itself.

Troubleshooting:

- Turn off the frequency converter and remove the earth fault.
- Measure the resistance to ground of the motor leads and the motor with a megohmmeter to check for earth faults in the motor.
- Perform current sensor test.

ALARM 15, Hardware mismatch

A fitted option is not operational with the present control board hardware or software.

Record the value of the following parameters and contact your Danfoss supplier:

15-40 FC Type

15-41 Power Section

15-42 Voltage

15-43 Software Version

15-45 Actual Typecode String

15-49 SW ID Control Card

15-50 SW ID Power Card

15-60 Option Mounted

15-61 Option SW Version

ALARM 16, Short circuit

There is short-circuiting in the motor or on the motor terminals.

Turn off the frequency converter and remove the short-circuit.

WARNING/ALARM 17, Control word timeout

There is no communication to the frequency converter. The warning will only be active when *8-04 Control Timeout Function* is NOT set to OFF.

If *8-04 Control Timeout Function* is set to *Stop* and *Trip*, a warning appears and the frequency converter ramps down until it trips, while giving an alarm.

Troubleshooting:

Check connections on the serial communication cable.

Increase *8-03 Control Timeout Time*

Check operation of the communication equipment.

Verify proper installation based on EMC requirements.

ALARM 18, Start failed

The speed has not been able to exceed *1-77 Compressor Start Max Speed [RPM]* during start within the allowed time. (set in *1-79 Compressor Start Max Time to Trip*).

This may be caused by a blocked motor.

WARNING 23, Internal fan fault

The fan warning function is an extra protection function that checks if the fan is running/mounted. The fan warning can be disabled in *14-53 Fan Monitor* ([0] Disabled).

For the D, E, and F Frame frequency converters, the regulated voltage to the fans is monitored.

Troubleshooting:

Check fan resistance.

Check soft charge fuses.

WARNING 24, External fan fault

The fan warning function is an extra protection function that checks if the fan is running/mounted. The fan warning can be disabled in *14-53 Fan Monitor* ([0] Disabled).

For the D, E, and F Frame frequency converters, the regulated voltage to the fans is monitored.

Troubleshooting:

Check fan resistance.

Check soft charge fuses.

WARNING 25, Brake resistor short circuit

The brake resistor is monitored during operation. If it short circuits, the brake function is disconnected and the warning appears. The frequency converter still works, but without the brake function. Turn off the frequency converter and replace the brake resistor (see *2-15 Brake Check*).

WARNING/ALARM 26, Brake resistor power limit

The power transmitted to the brake resistor is calculated: as a percentage, as a mean value over the last 120 seconds, on the basis of the resistance value of the brake resistor, and the intermediate circuit voltage. The warning is active when the dissipated braking power is higher than 90%. If *Trip* [2] has been selected in *2-13 Brake Power Monitoring*, the frequency converter cuts out and issues this alarm, when the dissipated braking power is higher than 100%.

WARNING/ALARM 27, Brake chopper fault

The brake transistor is monitored during operation and if it short-circuits, the brake function disconnects and issues a warning. The frequency converter is still able to run, but since the brake transistor has short-circuited, substantial power is transmitted to the brake resistor, even if it is inactive.

Turn off the frequency converter and remove the brake resistor.

This alarm/warning could also occur should the brake resistor overheat. Terminal 104 to 106 are available as brake resistor. Klixon inputs, see *4.6.9 Brake Resistor Temperature Switch*.

WARNING/ALARM 28, Brake check failed

Brake resistor fault: the brake resistor is not connected or not working.

Check *2-15 Brake Check*.

ALARM 29, Heatsink temp

The maximum temperature of the heatsink has been exceeded. The temperature fault will not be reset until the temperature falls below a defined heatsink temperature. The trip and reset point are different based on the frequency converter power size.

Troubleshooting:

- Ambient temperature too high.
- Too long motor cable.
- Incorrect clearance above and below the frequency converter.
- Dirty heatsink.
- Blocked air flow around the frequency converter.
- Damaged heatsink fan.

For the D, E, and F Frame frequency converters, this alarm is based on the temperature measured by the heatsink sensor mounted inside the IGBT modules. For the F Frame frequency converters, this alarm can also be caused by the thermal sensor in the Rectifier module.

Troubleshooting:

- Check fan resistance.
- Check soft charge fuses.
- IGBT thermal sensor.

ALARM 30, Motor phase U missing

Motor phase U between the frequency converter and the motor is missing.

Turn off the frequency converter and check motor phase U.

ALARM 31, Motor phase V missing

Motor phase V between the frequency converter and the motor is missing.

Turn off the frequency converter and check motor phase V.

ALARM 32, Motor phase W missing

Motor phase W between the frequency converter and the motor is missing.

Turn off the frequency converter and check motor phase W.

ALARM 33, Inrush fault

Too many power-ups have occurred within a short time period. Let unit cool to operating temperature.

WARNING/ALARM 34, Fieldbus communication fault

The fieldbus on the communication option card is not working.

WARNING/ALARM 35, Out of frequency range:

This warning is active if the output frequency has reached the high limit (set in par. 4-53) or low limit (set in par. 4-52). In *Process Control, Closed Loop* (par. 1-00) this warning is displayed.

WARNING/ALARM 36, Mains failure

This warning/alarm is only active if the supply voltage to the frequency converter is lost and *14-10 Mains Failure* is NOT set to OFF. Check the fuses to the frequency converter

ALARM 38, Internal fault

It may be necessary to contact your Danfoss supplier. Some typical alarm messages:

0	Serial port cannot be initialized. Serious hardware failure
256-258	Power EEPROM data is defect or too old
512	Control board EEPROM data is defect or too old
513	Communication time out reading EEPROM data
514	Communication time out reading EEPROM data
515	Application Orientated Control cannot recognize the EEPROM data
516	Cannot write to the EEPROM because a write command is on progress
517	Write command is under time out
518	Failure in the EEPROM
519	Missing or invalid Barcode data in EEPROM
783	Parameter value outside of min/max limits
1024-1279	A can-telegram that has to be sent, couldn't be sent
1281	Digital Signal Processor flash timeout
1282	Power micro software version mismatch
1283	Power EEPROM data version mismatch
1284	Cannot read Digital Signal Processor software version
1299	Option SW in slot A is too old
1300	Option SW in slot B is too old
1302	Option SW in slot C1 is too old
1315	Option SW in slot A is not supported (not allowed)
1316	Option SW in slot B is not supported (not allowed)
1318	Option SW in slot C1 is not supported (not allowed)
1379	Option A did not respond when calculating Platform Version.
1380	Option B did not respond when calculating Platform Version.
1536	An exception in the Application Orientated Control is registered. Debug information written in LCP
1792	DSP watchdog is active. Debugging of power part data Motor Orientated Control data not transferred correctly
2049	Power data restarted
2064-2072	H081x: option in slot x has restarted
2080-2088	H082x: option in slot x has issued a powerup-wait
2096-2104	H083x: option in slot x has issued a legal powerup-wait
2304	Could not read any data from power EEPROM
2305	Missing SW version from power unit
2314	Missing power unit data from power unit
2315	Missing SW version from power unit

2316	Missing io_statepage from power unit
2324	Power card configuration is determined to be incorrect at power up
2330	Power size information between the power cards does not match
2561	No communication from DSP to ATACD
2562	No communication from ATACD to DSP (state running)
2816	Stack overflow Control board module
2817	Scheduler slow tasks
2818	Fast tasks
2819	Parameter thread
2820	LCP Stack overflow
2821	Serial port overflow
2822	USB port overflow
2836	cfListMempool too small
3072-5122	Parameter value is outside its limits
5123	Option in slot A: Hardware incompatible with Control board hardware
5124	Option in slot B: Hardware incompatible with Control board hardware
5125	Option in slot C0: Hardware incompatible with Control board hardware
5126	Option in slot C1: Hardware incompatible with Control board hardware
5376-6231	Out of memory

Table 9.4
ALARM 39, Heatsink sensor

No feedback from the heatsink temperature sensor.

The signal from the IGBT thermal sensor is not available on the power card. The problem could be on the power card, on the gate drive card, or the ribbon cable between the power card and gate drive card.

WARNING 40, Overload of Digital Output Terminal 27

Check the load connected to terminal 27 or remove short-circuit connection. Check *5-00 Digital I/O Mode* and *5-01 Terminal 27 Mode*.

WARNING 41, Overload of Digital Output Terminal 29

Check the load connected to terminal 29 or remove short-circuit connection. Check *5-00 Digital I/O Mode* and *5-02 Terminal 29 Mode*.

WARNING 42, Overload of Digital Output on X30/6 or Overload of Digital Output on X30/7

For X30/6, check the load connected to X30/6 or remove short-circuit connection. Check *5-32 Term X30/6 Digi Out (MCB 101)*.

For X30/7, check the load connected to X30/7 or remove short-circuit connection. Check *5-33 Term X30/7 Digi Out (MCB 101)*.

ALARM 46, Power card supply

The supply on the power card is out of range.

There are three power supplies generated by the switch mode power supply (SMPS) on the power card: 24 V, 5 V, ± 18 V. When powered with 24 V DC with the MCB 107 option, only the 24 V and 5 V supplies are monitored. When powered with three phase mains voltage, all three supplied are monitored.

WARNING 47, 24 V supply low

The 24 V DC is measured on the control card. The external 24 V DC backup power supply may be overloaded, otherwise contact your Danfoss supplier.

WARNING 48, 1.8 V supply low

The 1.8 V DC supply used on the control card is outside of allowable limits. The power supply is measured on the control card.

WARNING 49, Speed limit

When the speed is not within the specified range in *4-11 Motor Speed Low Limit [RPM]* and *4-13 Motor Speed High Limit [RPM]* the frequency converter will show a warning. When the speed is below the specified limit in *1-86 Trip Speed Low [RPM]* (except when starting or stopping) the frequency converter will trip.

ALARM 50, AMA calibration failed

Contact your Danfoss supplier.

ALARM 51, AMA check Unom and Inom

The setting of motor voltage, motor current, and motor power is presumably wrong. Check the settings.

ALARM 52, AMA low Inom

The motor current is too low. Check the settings.

ALARM 53, AMA motor too big

The motor is too big for the AMA to be carried out.

ALARM 54, AMA motor too small

The motor is too small for the AMA to be carried out.

ALARM 55, AMA Parameter out of range

The parameter values found from the motor are outside acceptable range.

ALARM 56, AMA interrupted by user

The AMA has been interrupted by the user.

ALARM 57, AMA timeout

Try to start the AMA again a number of times, until the AMA is carried out. Please note that repeated runs may heat the motor to a level where the resistance R_s and R_r are increased. In most cases, however, this is not critical.

ALARM 58, AMA internal fault

Contact your Danfoss supplier.

WARNING 59, Current limit

The current is higher than the value in *4-18 Current Limit*.

WARNING 60, External interlock

External interlock has been activated. To resume normal operation, apply 24 V DC to the terminal programmed for external interlock and reset the frequency converter (via serial communication, digital I/O, or by pressing [Reset]).

WARNING 62, Output frequency at maximum limit

The output frequency is higher than the value set in 4-19 *Max Output Frequency*

WARNING 64, Voltage limit

The load and speed combination demands a motor voltage higher than the actual DC link voltage.

WARNING/ALARM/TRIP 65, Control card over temperature

Control card over temperature: The cutout temperature of the control card is 80 °C.

WARNING 66, Heatsink temperature low

This warning is based on the temperature sensor in the IGBT module.

Troubleshooting:

The heatsink temperature measured as 0 °C could indicate that the temperature sensor is defective causing the fan speed to increase to the maximum. If the sensor wire between the IGBT and the gate drive card is disconnected, this warning would result. Also, check the IGBT thermal sensor.

ALARM 67, Option module configuration has changed

One or more options have either been added or removed since the last power-down.

ALARM 68, Safe stop activated

Safe stop has been activated. To resume normal operation, apply 24 V DC to terminal 37, then send a reset signal (via Bus, Digital I/O, or by pressing the reset key. See 5-19 *Terminal 37 Safe Stop*.

ALARM 69, Power card temperature

The temperature sensor on the power card is either too hot or too cold.

Troubleshooting:

Check the operation of the door fans.

Check that the filters for the door fans are not blocked.

Check that the gland plate is properly installed on IP 21 and IP 54 (NEMA 1 and NEMA 12) frequency converters.

ALARM 70, Illegal FC Configuration

Actual combination of control board and power board is illegal.

ALARM 72, Dangerous failure

Safe stop with trip lock. Unexpected signal levels on safe stop and digital input from the MCB 112 PTC thermistor card.

WARNING 73, Safe stop auto restart

Safe stopped. Note that with automatic restart enabled, the motor may start when the fault is cleared.

WARNING 76, Power Unit Setup

The required number of power units does not match the detected number of active power units.

Troubleshooting:

When replacing an F-frame module, this will occur if the power specific data in the module power card does not match the rest of the frequency converter. Please confirm the spare part and its power card are the correct part number.

WARNING 77, Reduced power mode:

This warning indicates that the frequency converter is operating in reduced power mode (i.e. less than the allowed number of inverter sections). This warning will be generated on power cycle when the frequency converter is set to run with fewer inverters and will remain on.

ALARM 79, Illegal power section configuration

The scaling card is the incorrect part number or not installed. Also MK102 connector on the power card could not be installed.

ALARM 80, Drive initialized to default value

Parameter settings are initialized to default settings after a manual reset.

ALARM 91, Analog input 54 wrong settings

Switch S202 has to be set in position OFF (voltage input) when a KTY sensor is connected to analog input terminal 54.

ALARM 92, No flow

A no-load situation has been detected in the system. See parameter group 22-2*.

ALARM 93, Dry pump

A no-flow situation and high speed indicates that the pump has run dry. See parameter group 22-2*.

ALARM 94, End of curve

Feedback stays lower than the set point which may indicate leakage in the pipe system. See parameter group 22-5*.

ALARM 95, Broken belt

Torque is below the torque level set for no load, indicating a broken belt. See parameter group 22-6*.

ALARM 96, Start delayed

Motor start has been delayed due to short-cycle protection active. See parameter group 22-7*.

WARNING 97, Stop delayed

Stopping the motor has been delayed due to short cycle protection is active. See parameter group 22-7*.

WARNING 98, Clock fault

Clock Fault. Time is not set or RTC clock (if mounted) has failed. See parameter group 0-7*.

WARNING 201, Fire Mode was Active

Fire Mode has been active.

WARNING 202, Fire Mode Limits Exceeded

Fire Mode has suppressed one or more warranty voiding alarms.

WARNING 203, Missing Motor

A multi-motor under-load situation was detected, this could be due to e.g. a missing motor.

WARNING 204, Locked Rotor

A multi-motor overload situation was detected, this could be due to e.g. a locked rotor.

ALARM 243, Brake IGBT

This alarm is only for F Frame frequency converters. It is equivalent to Alarm 27. The report value in the alarm log indicates which power module generated the alarm:

- 1 = left most inverter module.
- 2 = middle inverter module in F2 or F4 frequency converter.
- 2 = right inverter module in F1 or F3 frequency converter.
- 3 = right inverter module in F2 or F4 frequency converter.
- 5 = rectifier module.

ALARM 244, Heatsink temperature

This alarm is only for F Frame frequency converters. It is equivalent to Alarm 29. The report value in the alarm log indicates which power module generated the alarm:

- 1 = left most inverter module.
- 2 = middle inverter module in F2 or F4 frequency converter.
- 2 = right inverter module in F1 or F3 frequency converter.
- 3 = right inverter module in F2 or F4 frequency converter.
- 5 = rectifier module.

ALARM 245, Heatsink sensor

This alarm is only for F Frame frequency converters. It is equivalent to Alarm 39. The report value in the alarm log indicates which power module generated the alarm:

- 1 = left most inverter module.
- 2 = middle inverter module in F2 or F4 frequency converter.
- 2 = right inverter module in F1 or F3 frequency converter.
- 3 = right inverter module in F2 or F4 frequency converter.
- 5 = rectifier module.

ALARM 246, Power card supply

This alarm is only for F Frame frequency converters. It is equivalent to Alarm 46. The report value in the alarm log indicates which power module generated the alarm:

- 1 = left most inverter module.
- 2 = middle inverter module in F2 or F4 frequency converter.
- 2 = right inverter module in F1 or F3 frequency converter.

3 = right inverter module in F2 or F4 frequency converter.

5 = rectifier module.

ALARM 247, Power card temperature

This alarm is only for F Frame frequency converters. It is equivalent to Alarm 69. The report value in the alarm log indicates which power module generated the alarm:

- 1 = left most inverter module.
- 2 = middle inverter module in F2 or F4 frequency converter.
- 2 = right inverter module in F1 or F3 frequency converter.
- 3 = right inverter module in F2 or F4 frequency converter.
- 5 = rectifier module.

ALARM 248, Illegal power section configuration

This alarm is only for F Frame frequency converters. It is equivalent to Alarm 79. The report value in the alarm log indicates which power module generated the alarm:

- 1 = left most inverter module.
- 2 = middle inverter module in F2 or F4 frequency converter.
- 2 = right inverter module in F1 or F3 frequency converter.
- 3 = right inverter module in F2 or F4 frequency converter.
- 5 = rectifier module.

ALARM 250, New spare part

The power or switch mode power supply has been exchanged. The frequency converter type code must be restored in the EEPROM. Select the correct type code in *14-23 Typecode Setting* according to the label on the unit. Remember to select 'Save to EEPROM' to complete.

ALARM 251, New type code

The frequency converter has a new type code.

9.2 Alarms and Warnings - Filter (Left LCP)

NOTE

This sections covers warnings and alarms on the filter side LCP. For warning and alarms for the frequency converter, please see previous section

A warning or an alarm is signalled by the relevant LED on the front of the filter and indicated by a code on the display.

A warning remains active until its cause is no longer present. Under certain circumstances operation of the unit may still be continued. Warning messages may be critical, but are not necessarily so.

In the event of an alarm, the unit will have tripped. Alarms must be reset to restart operation once their cause has been rectified.

This may be done in four ways:

1. By pressing [Reset].
2. Via a digital input with the "Reset" function.
3. Via serial communication/optional fieldbus.
4. By resetting automatically using the [Auto Reset] function. See *14-20 Reset Mode* in the VLT Active Filter AAF 005 Operating Instructions.

NOTE

After a manual reset pressing [Reset], [Auto On] or [Hand On] must be pressed to restart the unit.

If an alarm cannot be reset, the reason may be that its cause has not been rectified, or the alarm is trip-locked (see also *Table 9.5*).

Alarms that are trip-locked offer additional protection, means that the mains supply must be switched off before the alarm can be reset. After being switched back on, the unit is no longer blocked and may be reset as described above once the cause has been rectified.

Alarms that are not trip-locked can also be reset using the automatic reset function in *14-20 Reset Mode* (Warning: automatic wake-up is possible!)

If a warning and alarm is marked against a code in the table on the following page, this means that either a warning occurs before an alarm, or it can be specified whether it is a warning or an alarm that is to be displayed for a given fault.

No.	Description	Warning	Alarm/Trip	Alarm/Trip Lock	Parameter Reference
1	10 Volts low	X			
2	Live zero error	(X)	(X)		6-01
4	Mains phase loss		X		
5	DC link voltage high	X			
6	DC link voltage low	X			
7	DC over voltage	X	X		
8	DC under voltage	X	X		
13	Over Current	X	X	X	
14	Earth fault	X	X	X	
15	Hardware mismatch		X	X	
16	Short Circuit		X	X	
17	Control word timeout	(X)	(X)		8-04
23	Internal Fan Fault	X			
24	External Fan Fault	X			14-53
29	Heatsink temp	X	X	X	
33	Inrush fault		X	X	
34	Fieldbus fault	X	X		
35	Option fault	X	X		
38	Internal fault				
39	Heatsink sensor		X	X	
40	Overload of Digital Output Terminal 27	(X)			5-00, 5-01
41	Overload of Digital Output Terminal 29	(X)			5-00, 5-02
42	Overload of Digital Output On X30/6	(X)			5-32
42	Overload of Digital Output On X30/7	(X)			5-33

No.	Description	Warning	Alarm/Trip	Alarm/Trip Lock	Parameter Reference
46	Pwr. card supply		X	X	
47	24 V supply low	X	X	X	
48	1.8 V supply low		X	X	
65	Control Board Over-temperature	X	X	X	
66	Heat sink Temperature Low	X			
67	Option Configuration has Changed		X		
68	Safe Stop Activated		X ⁽¹⁾		
69	Pwr. Card Temp		X	X	
70	Illegal FC configuration			X	
72	Dangerous Failure			X ⁽¹⁾	
73	Safe Stop Auto Restart				
76	Power Unit Setup	X			
79	Illegal PS config		X	X	
80	Drive Initialised to Default Value		X		
244	Heatsink temp	X	X	X	
245	Heatsink sensor		X	X	
246	Pwr.card supply		X	X	
247	Pwr.card temp		X	X	
248	Illegal PS config		X	X	
250	New spare part			X	
251	New Type Code		X	X	
300	Mains Cont. fault			X	
301	SC Cont. Fault			X	
302	Cap. Over Current	X	X		
303	Cap. Earth Fault	X	X		
304	DC Over Current	X	X		
305	Mains Freq. Limit		X		
306	Compensation Limit	X			
308	Resistor temp	X		X	
309	Mains Earth Fault	X	X		
311	Switch. Freq. Limit		X		
312	CT Range		X		
314	Auto CT Interrupt		X		
315	Auto CT Error		X		
316	CT Location Error		X		
317	CT Polarity Error		X		
318	CT Ratio Error		X		

Table 9.5 Alarm/Warning Code List

A trip is the action when an alarm has appeared. The trip will coast the motor and can be reset by pressing the reset button or make a reset by a digital input (Parameter group 5-1* [1]). The origin event that caused an alarm cannot damage the frequency converter or cause dangerous conditions. A trip lock is an action when an alarm occurs, which may cause damage to frequency converter or connected parts. A Trip Lock situation can only be reset by a power cycling.

Warning	yellow
Alarm	flashing red
Trip locked	yellow and red

Table 9.6 LED Indication

Alarm Word and Extended Status Word					
Bit	Hex	Dec	Alarm Word	Warning Word	Extended Status Word
0	00000001	1	Mains Cont. Fault	Reserved	Reserved
1	00000002	2	Heatsink Temp	Heatsink Temp	Auto CT Running
2	00000004	4	Earth Fault	Earth Fault	Reserved
3	00000008	8	Ctrl.Card Temp	Ctrl.Card Temp	Reserved
4	00000010	16	Ctrl. Word TO	Ctrl. Word TO	Reserved
5	00000020	32	Over Current	Over Current	Reserved
6	00000040	64	SC Cont. Fault	Reserved	Reserved
7	00000080	128	Cap. Over Current	Cap. Over Current	Reserved
8	00000100	256	Cap. Earth Fault	Cap. Earth Fault	Reserved
9	00000200	512	Inverter Overld.	Inverter Overld.	Reserved
10	00000400	1024	DC under Volt	DC under Volt	Reserved
11	00000800	2048	DC over Volt	DC over Volt	Reserved
12	00001000	4096	Short Circuit	DC Voltage Low	Reserved
13	00002000	8192	Inrush Fault	DC Voltage High	Reserved
14	00004000	16384	Mains ph. Loss	Mains ph. Loss	Reserved
15	00008000	32768	Auto CT Error	Reserved	Reserved
16	00010000	65536	Reserved	Reserved	Reserved
17	00020000	131072	Internal Fault	10V Low	Password Time Lock
18	00040000	262144	DC Over Current	DC Over Current	Password Protection
19	00080000	524288	Resistor temp	Resistor temp	Reserved
20	00100000	1048576	Mains Earth Fault	Mains Earth Fault	Reserved
21	00200000	2097152	Switch. Freq. Limit	Reserved	Reserved
22	00400000	4194304	Fieldbus Fault	Fieldbus Fault	Reserved
23	00800000	8388608	24 V Supply Low	24V Supply Low	Reserved
24	01000000	16777216	CT Range	Reserved	Reserved
25	02000000	33554432	1.8V Supply Low	Reserved	Reserved
26	04000000	67108864	Reserved	Low Temp	Reserved
27	08000000	134217728	Auto CT Interrupt	Reserved	Reserved
28	10000000	268435456	Option Change	Reserved	Reserved
29	20000000	536870912	Unit Initialized	Unit Initialized	Reserved
30	40000000	1073741824	Safe Stop	Safe Stop	Reserved
31	80000000	2147483648	Mains Freq. Limit	Extended Status Word	Reserved

Table 9.7 Description of Alarm Word, Warning Word and Extended Status Word

The alarm words, warning words and extended status words can be read out via serial bus or optional fieldbus for diagnosis. See also *16-90 Alarm Word*, *16-92 Warning Word* and *16-94 Ext. Status Word*. "Reserved" means that the bit is not guaranteed to be any particular value. Reserved bits should not be used for any purpose.

9.2.1 Fault Messages

WARNING 1, 10 volts low

The control card voltage is below 10 V from terminal 50. Remove some of the load from terminal 50, as the 10 V supply is overloaded. Max. 15 mA or minimum 590 Ω.

WARNING/ALARM 2, Live zero error

The signal on terminal 53 or 54 is less than 50% of the value set in *6-10 Terminal 53 Low Voltage*, *6-12 Terminal 53 Low Current*, *6-20 Terminal 54 Low Voltage* or *6-22 Terminal 54 Low Current* respectively.

WARNING/ALARM 4, Mains phase loss

A phase is missing on the supply side, or the mains voltage imbalance is too high.

WARNING 5, DC link voltage high

The intermediate circuit voltage (DC) is higher than the high voltage warning limit. The unit is still active.

WARNING 6, DC link voltage low

The intermediate circuit voltage (DC) is below the under-voltage limit of the control system. The unit is still active.

WARNING/ALARM 7, DC overvoltage

If the intermediate circuit voltage exceeds the limit, the unit trips.

WARNING/ALARM 8, DC under voltage

If the intermediate circuit voltage (DC) drops below the under voltage limit, the filter checks if a 24 V backup supply is connected. If not, the unit trips. Check that the mains voltage matches the nameplate specification.

WARNING/ALARM 13, Over Current

the unit current limit has been exceeded.

ALARM 14, Earth (ground) fault

The sum current of the IGBT CT's does not equal zero. Check if the resistance of any phase to ground has a low value. Make sure to check both before and after mains contactor. Also make sure IGBT current transducers, connection cables, and connectors are ok.

ALARM 15, Incomp. Hardware

A mounted option is not handled by the present Control Card SW/HW.

ALARM 16, Short circuit

There is a short-circuit in the output. Turn off the unit and correct the error.

WARNING/ALARM 17, Control word timeout

There is no communication to the unit.

The warning will only be active when *8-04 Control Word Timeout Function* is NOT set to OFF.

Possible correction: Increase *8-03 Control Timeout Time*. Change *8-04 Control Word Timeout Function*.

WARNING 23, Internal fan fault

Internal fans have failed due to defect hardware or fans not mounted.

WARNING 24, External fan fault

External fans have failed due to defect hardware or fans not mounted.

ALARM 29, Heatsink temp

The maximum temperature of the heatsink has been exceeded. The temperature fault will not be reset until the temperature falls below a defined heatsink temperature.

ALARM 33, Inrush fault

Check whether a 24 V DC supply has been connected.

WARNING/ALARM 34, Fieldbus communication fault

The fieldbus on the communication option card is not working.

WARNING/ALARM 35, Option Fault:

Contact your Danfoss supplier.

ALARM 38, Internal fault

Contact your Danfoss supplier.

ALARM 39, Heatsink sensor

No feedback from the heatsink temperature sensor.

WARNING 40, Overload of Digital Output Terminal 27

Check the load connected to terminal 27 or remove short-circuit connection.

WARNING 41, Overload of Digital Output Terminal 29

Check the load connected to terminal 29 or remove short-circuit connection.

WARNING 42, Overload of Digital Output on X30/6 or Overload of Digital Output on X30/7

For X30/6, check the load connected to X30/6 or remove short-circuit connection.

For X30/7, check the load connected to X30/7 or remove short-circuit connection.

WARNING 43, Ext. Supply (option)

The external 24 V DC supply voltage on the option is not valid.

ALARM 46, Power card supply

The supply on the power card is out of range.

WARNING 47, 24 V supply low

Contact your Danfoss supplier.

WARNING 48, 1.8 V supply low

Contact your Danfoss supplier.

WARNING/ALARM/TRIP 65, Control card over temperature

Control card over temperature: The cutout temperature of the control card is 80 °C.

WARNING 66, Heatsink temperature low

This warning is based on the temperature sensor in the IGBT module.

Troubleshooting:

The heatsink temperature measured as 0 °C could indicate that the temperature sensor is defective causing the fan speed to increase to the maximum. If the sensor wire between the IGBT and the gate drive card is disconnected,

this warning would result. Also, check the IGBT thermal sensor.

ALARM 67, Option module configuration has changed

One or more options have either been added or removed since the last power-down.

ALARM 68, Safe stop activated

Safe stop has been activated. To resume normal operation, apply 24 V DC to terminal 37, then send a reset signal (via Bus, Digital I/O, or by pressing the reset key. See 5-19 Terminal 37 Safe Stop.

ALARM 69, Power card temperature

The temperature sensor on the power card is either too hot or too cold.

ALARM 70, Illegal FC Configuration

Actual combination of control board and power board is illegal.

WARNING 73, Safe stop auto restart

Safe stopped. Note that with automatic restart enabled, the motor may start when the fault is cleared.

WARNING 77, Reduced power mode:

This warning indicates that the drive is operating in reduced power mode (i.e. less than the allowed number of inverter sections). This warning will be generated on power cycle when the drive is set to run with fewer inverters and will remain on.

ALARM 79, Illegal power section configuration

The scaling card is the incorrect part number or not installed. Also MK102 connector on the power card could not be installed.

ALARM 80, Unit initialized to default value

Parameter settings are initialized to default settings after a manual reset.

ALARM 244, Heatsink temperature

Report value indicates source of alarm (from left):

1-4 Inverter

5-8 Rectifier

ALARM 245, Heatsink sensor

No feedback from the heatsink sensor. Report value indicates source of alarm (from left):

1-4 Inverter

5-8 Rectifier

ALARM 246, Power card supply

The supply on the power card is out of range Report value indicates source of alarm (from left):

1-4 Inverter

5-8 Rectifier

ALARM 247, Power card temperature

Power card over temperature Report value indicates source of alarm (from left):

1-4 Inverter

5-8 Rectifier

ALARM 248, Illegal power section configuration

Power size configuration fault on the power card Report value indicates source of alarm (from left):

1-4 Inverter

5-8 Rectifier

ALARM 249, Rect. low temp.

The temperature of the rectifier heat sink is too low. This could indicate that the temperature sensor is defect.

ALARM 250, New spare part

The power or switch mode power supply has been exchanged. The filter type code must be restored in the EEPROM. Select the correct type code in 14-23 Typecode Setting according to the label on the unit. Remember to select 'Save to EEPROM' to complete.

ALARM 251, New type code

The filter has a new type code.

ALARM 300, Mains Cont. Fault

The feedback from the mains contactor did not match the expected value within the allowed time frame. Contact your Danfoss supplier.

ALARM 301, SC Cont. Fault

The feedback from the soft charge contactor did not match the expected value within the allowed time frame. Contact your Danfoss supplier.

ALARM 302, Cap. Over Current

Excessive current was detected through the AC capacitors. Contact your Danfoss supplier.

ALARM 303, Cap. Earth Fault

An earth fault was detected through the AC capacitor currents. Contact your Danfoss supplier.

ALARM 304, DC Over Current

Excessive current through the DC link capacitor bank was detected. Contact your Danfoss supplier.

ALARM 305, Mains Freq. Limit

The mains frequency was outside the limits. Verify that the mains frequency is within product specification.

ALARM 306, Compensation Limit

The needed compensation current exceeds unit capability. Unit is running at full compensation.

ALARM 308, Resistor temp

Excessive resistor heatsink temperature detected.

ALARM 309, Mains Earth Fault

An earth fault was detected in the mains currents. Check the mains for shorts and leakage current.

ALARM 310, RTDC Buffer Full

Contact your Danfoss supplier.

ALARM 311, Switch. Freq. Limit

The average switching frequency of the unit exceeded the limit. Verify that 300-10 Active Filter Nominal Voltage and 300-22 CT Nominal Voltage are set correctly. If so, contact your Danfoss supplier.

ALARM 312, CT Range

Current transformer measurement limitation was detected.
Verify that the CTs used are an appropriate ratio.

ALARM 314, Auto CT Interrupt

Auto CT detection was interrupted by the user.

ALARM 315, Auto CT Error

An error was detected while performing auto CT detection.
Contact your Danfoss supplier.

ALARM 316, CT Location Error

The Auto CT function could not determine the correct locations of the CTs.

ALARM 317, CT Polarity Error

The Auto CT function could not determine the correct polarity of the CTs.

ALARM 318, CT Ratio Error

The Auto CT function could not determine the correct primary rating of the CTs.

Index

A

Acceleration Time..... 73

Access To Control Terminals..... 51

AF

 Readouts..... 126

 Settings..... 125

Airflow..... 28

Alarm/Warning Code List..... 144, 154

Alarms And Warnings..... 142, 153

AMA..... 56, 57

Analog

 Inputs..... 135

 Output..... 135

Auto

 Energy Optimization Compressor..... 77

 Energy Optimization VT..... 78

Automatic Motor Adaptation (AMA)..... 56

B

Back Cooling..... 28

Brake

 Cable..... 45

 Resistor Temperature Switch..... 45

Branch Circuit Protection..... 46

C

Cable Lengths And Cross Sections..... 134

Cable-length And Cross-section..... 35

Cabling..... 34

Changes Made..... 70

Changing

 A Group Of Numeric Data Values..... 63

 A Text Value..... 63

 Data..... 62

 Of Data Value..... 63

 Parameter Data..... 70

Coast Inverse..... 71

Coasting..... 62

Comm. And Options..... 122

Communication Option..... 149

Control

 Cables..... 55, 54

 Card Performance..... 137

 Card, 10 V DC Output..... 136

 Card, 24 V DC Output..... 136

 Card, RS-485 Serial Communication..... 135

 Card, USB Serial Communication..... 137

 Characteristics..... 136

 Terminals..... 51

Cooling..... 80, 28

Copyright, Limitation Of Liability And Revision Rights..... 5

D

Data Readouts..... 124

DC Link..... 146, 156

Default Settings..... 64

Digital

 In/Out..... 121

 Inputs..... 134

 Output..... 136

Disposal Instruction..... 11

Drip Shield Installation..... 32

Drives With Factory Installed Brake Chopper Option..... 45

E

Earthing..... 43

ELCB Relays..... 43

Electrical Installation..... 51, 54

Electronic Waste..... 11

EMC Precautions..... 128

Example Of Changing Parameter Data..... 70

External

 Fan Supply..... 46

 Temperature Monitoring..... 34

F

Fault Messages..... 146, 156

FC Information..... 122

Fieldbus Connection..... 49

Frame Size F Panel Options..... 33

Function Set-ups..... 74

Fuse Specifications..... 47

Fuses..... 46

Fusing..... 34

G

General Considerations..... 21

Gland/Conduit Entry - IP21 (NEMA 1) And IP54 (NEMA12)... 29

GLCP..... 63

Graphical Display..... 59

H

How

 To Connect A PC To The Frequency Converter..... 65

 To Operate Graphical LCP (GLCP)..... 59

I

IEC Emergency Stop With Pilz Safety Relay..... 33

Index (IND)..... 131

Indexed Parameters	63	NAMUR	33
Indicator Lights (LEDs)	60	Network Connection	127
Initialisation	64	No Operation	71
Input Polarity Of Control Terminals	55	Non UL Compliance	46
Installation		O	
At High Altitudes.....	7	Operation/Display	120
Of Input Plate Options.....	32	Output Performance (U, V, W)	134
Of Mains Shield For Frequency Converters.....	33		
Insulation Resistance Monitor (IRM)	33	P	
IT Mains	43	Parallel Connection Of Motors	58
		Parameter	
K		Data.....	70
KTY Sensor	147	Selection.....	95
		Set-Up.....	67
L		Values.....	133
Language		PC Software Tools	65
Package 1.....	71	Planning The Installation Site	14
Package 2.....	71	Potentiometer Reference	53
Package 3.....	71	Power Connections	34
Package 4.....	71	Profibus DP-V1	65
LCP 102	59	Protection And Features	137
Leakage Current	8	Protocol Overview	128
LEDs	59	Pulse	
Lifting	15	Inputs.....	135
Literature	5	Start/Stop.....	52
Load Sharing	45		
Loggings	70	Q	
		Quick	
M		Menu.....	61, 69
Main		Menu Mode.....	61, 70
Menu.....	69	Transfer Of Parameter Settings When Using GLCP.....	63
Menu Mode.....	61, 95		
Menu Structure.....	97	R	
Reactance.....	78	RCD (Residual Current Device)	33
Mains		Receiving The Frequency Converter	15
Connection.....	45	Relay Outputs	136
Supply (L1, L2, L3).....	134	Reset	62
Manual Motor Starters	33	Residual Current Device	8
MCT 10	65	RFI Switch	43
Mechanical		RS-485	
Brake Control.....	57	RS-485.....	127
Dimensions.....	16	Bus Connection.....	64
Installation.....	21		
Motor		S	
Bearing Currents.....	49	Safe Stop Installation	8
Cable.....	44	Safety	
Name Plate.....	56	Category 3 (EN 954-1).....	9
Output.....	134	Note.....	7
Protection.....	80, 137	Screened/armoured	46
Thermal Protection.....	58		
N			
Name Plate Data	56		

Screening Of Cables.....	35
Serial Communication.....	137
Shielded Cables.....	44
Sine-wave Filter.....	35
Space	
Space.....	21
Heaters And Thermostat.....	33
Special Functions	122
Speed Up/Down	52
Start/Stop	52
Stator Leakage Reactance	78
Status	
Status.....	61
Messages.....	59
Step-by-Step	63
Stopping Category 0 (EN 60204-1)	9
Surroundings	137
Switches S201, S202, And S801	56
Switching Frequency	35
Symbols	6
T	
Telegram Length (LGE)	129
Terminal Locations - Frame Size D13	22
Thermistor	80
Torque	
Torque.....	43
Characteristics.....	134
For Terminals.....	44
U	
Unpacking	15
V	
Voltage	
Level.....	134
Reference Via A Potentiometer.....	53
W	
Warning Against Unintended Start	7
Wire Access	21