



Instruction Manual

VLT[®] Refrigeration Drive FC 103

1.1–90 kW



Safety

⚠ WARNING

HIGH VOLTAGE!

Adjustable frequency drives contain high voltage when connected to AC line power. Installation, start-up, and maintenance should be performed by qualified personnel only. Failure to perform installation, start-up, and maintenance by qualified personnel could result in death or serious injury.

High Voltage

Adjustable frequency drives are connected to hazardous AC line voltage. Extreme care should be taken to protect against shock. Only trained personnel familiar with electronic equipment should install, start, or maintain this equipment.

⚠ WARNING

UNINTENDED START!

When the adjustable frequency drive is connected to AC line power, the motor may start at any time. The adjustable frequency drive, motor, and any driven equipment must be in operational readiness. Failure to be in operational readiness when the adjustable frequency drive is connected to AC line power could result in death, serious injury, equipment, or property damage.

Unintended Start

When the adjustable frequency drive is connected to the AC line power, the motor may be started by means of an external switch, a serial bus command, an input reference signal, or a cleared fault condition. Use appropriate cautions to guard against an unintended start.

⚠ WARNING

DISCHARGE TIME!

Adjustable frequency drives contain DC link capacitors that can remain charged even when the adjustable frequency drive is not powered. To avoid electrical hazards, disconnect AC line power, any permanent magnet type motors, and any remote DC link power supplies, including battery backups, UPS and DC link connections to other adjustable frequency drives. Wait for the capacitors to fully discharge before performing any service or repair work. The wait time required is listed in the *Discharge Time* table. Failure to wait for the specified period of time after power has been removed to do service or repair could result in death or serious injury.

Voltage [V]	Minimum waiting time [minutes]	
	4	15
200–240	1.5–5 hp [1.1–3.7 kW]	7.5–50 hp [5.5–37 kW]
380–480	1.5–10 hp [1.1–7.5 kW]	15–100 hp [11–75 kW]
525–600	1–10 hp [0.75–7.5 kW]	15–100 hp [11–75 kW]

High voltage may be present even when the warning LEDs are off!

Discharge Time

Symbols

The following symbols are used in this manual.

⚠ WARNING

Indicates a potentially hazardous situation which, if not avoided, could result in death or serious injury.

⚠ CAUTION

Indicates a potentially hazardous situation which, if not avoided, may result in minor or moderate injury. It may also be used to alert against unsafe practices.

CAUTION

Indicates a situation that may result in equipment or property damage-only accidents.

NOTICE!

Indicates highlighted information that should be observed in order to avoid mistakes or operate equipment at less than optimal performance.



Approvals

NOTICE!

Imposed limitations on the output frequency (due to export control regulations):

As of software version 1.10, the output frequency of the adjustable frequency drive is limited to 590 Hz.

Contents

1 Introduction	4
1.1 Purpose of the Manual	6
1.2 Product Overview	6
1.3 Internal Adjustable Frequency Drive Controller Functions	6
1.4 Frame Sizes and Power Ratings	7
2 Installation	8
2.1 Installation Site Checklist	8
2.2 Pre-installation Checklist	8
2.3 Mechanical Installation	8
2.3.1 Cooling	8
2.3.2 Lifting	9
2.3.3 Mounting	9
2.3.4 Tightening Torques	10
2.4 Electrical Installation	10
2.4.1 Requirements	13
2.4.2 Grounding Requirements	14
2.4.2.1 Leakage Current (>3.5 mA)	14
2.4.2.2 Grounding Using Shielded Cable	15
2.4.3 Access	15
2.4.4 Motor Connection	16
2.4.4.1 Motor Connection for A2 and A3	17
2.4.4.2 Motor Connection for A4 and A5	18
2.4.4.3 Motor Connection for B1 and B2	18
2.4.4.4 Motor Connection for C1 and C2	19
2.4.5 AC Line Power Connection	19
2.4.5.1 AC Line Input Connection for A2 and A3	20
2.4.5.2 AC Line Input Connection for A4 and A5	21
2.4.5.3 AC Line Input Connection for B1 and B2	22
2.4.5.4 AC Line Input Connection for C1 and C2	22
2.4.6 Control Wiring	23
2.4.6.1 Control Terminal Types	23
2.4.6.2 Wiring to Control Terminals	24
2.4.6.3 Using Shielded Control Cables	24
2.4.6.4 Jumper Terminals 12 and 27	25
2.4.6.5 Terminal 53 and 54 Switches	25
2.4.6.6 Terminal 37	26

2.4.7 Serial Communication	29
3 Start-up and Functional Test	30
3.1 Pre-start	30
3.1.1 Safety Inspection	30
3.2 Applying Power	32
3.3 Basic Operational Programming	32
3.3.1 Set-up Wizard	32
3.4 Asynchronous Motor Set-up	38
3.5 Automatic Motor Adaptation	38
3.6 PM Motor Set-up in VVC ^{plus}	38
3.7 Check Motor Rotation	40
3.8 Local Control Test	40
3.9 System Start-up	41
4 User Interface	42
4.1 Local Control Panel	42
4.1.1 LCP Layout	42
4.1.2 Setting LCP Display Values	43
4.1.3 Display Menu Keys	43
4.1.4 Navigation Keys	44
4.1.5 Operation Keys	44
4.2 Backup and Copying Parameter Settings	45
4.2.1 Uploading Data to the LCP	45
4.2.2 Downloading Data from the LCP	45
4.3 Restoring Default Settings	45
4.3.1 Recommended Initialization	46
4.3.2 Manual Initialization	46
4.4 How to Operate	46
4.5 Remote Programming with MCT 10 Set-up Software	46
5 Programming	47
5.1 Introduction	47
5.2 Programming Example	47
5.3 Control Terminal Programming Examples	49
5.4 International/North American Default Parameter Settings	49
5.5 Parameter Menu Structure	50
5.5.1 Quick Menu Structure	51
5.5.2 Main Menu Structure	53

6 Application Set-up Examples	57
6.1 Introduction	57
6.2 Set-up Examples	57
6.2.1 Compressor	57
6.2.2 Single or Multiple Fans or Pumps	58
6.2.3 Compressor Pack	59
7 Status Messages	60
7.1 Status Display	60
7.2 Status Message Definitions	60
8 Warnings and Alarms	63
8.1 System Monitoring	63
8.2 Warning and Alarm Types	63
8.3 Warning and Alarm Displays	63
8.4 Warning and Alarm Definitions	64
9 Basic Troubleshooting	73
9.1 Start-up and Operation	73
10 Specifications	76
10.1 Power-dependent Specifications	76
10.2 General Technical Data	85
10.3 Fuse Specifications	91
10.3.1 Branch Circuit Protection Fuses	91
10.3.2 Substitute Fuses for 240 V	93
10.4 Connection Tightening Torques	93
Index	94

1

1 Introduction

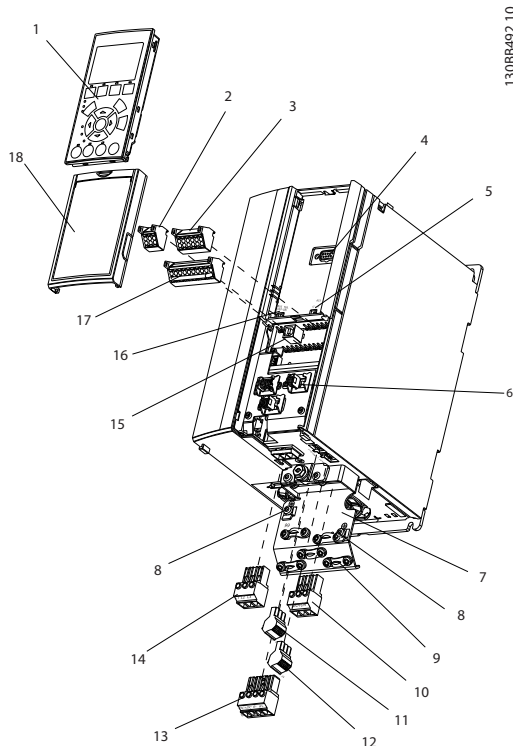

130BB492.10

Figure 1.1 Exploded View Frame Size A

1	LCP	10	Motor output terminals 96 (U), 97 (V), 98 (W)
2	RS-485 serial bus connector (+68, -69)	11	Relay 2 (01, 02, 03)
3	Analog I/O connector	12	Relay 1 (04, 05, 06)
4	LCP input plug	13	Brake (-81, +82) and load sharing (-88, +89) terminals
5	Analog switches (A53), (A54)	14	Line power input terminals 91 (L1), 92 (L2), 93 (L3)
6	Cable strain relief/PE ground	15	USB connector
7	Decoupling plate	16	Serial bus terminal switch
8	Grounding clamp (PE)	17	Digital I/O and 24 V power supply
9	Shielded cable grounding clamp and strain relief	18	Control cable cover plate

Table 1.1 Legend to Figure 1.1

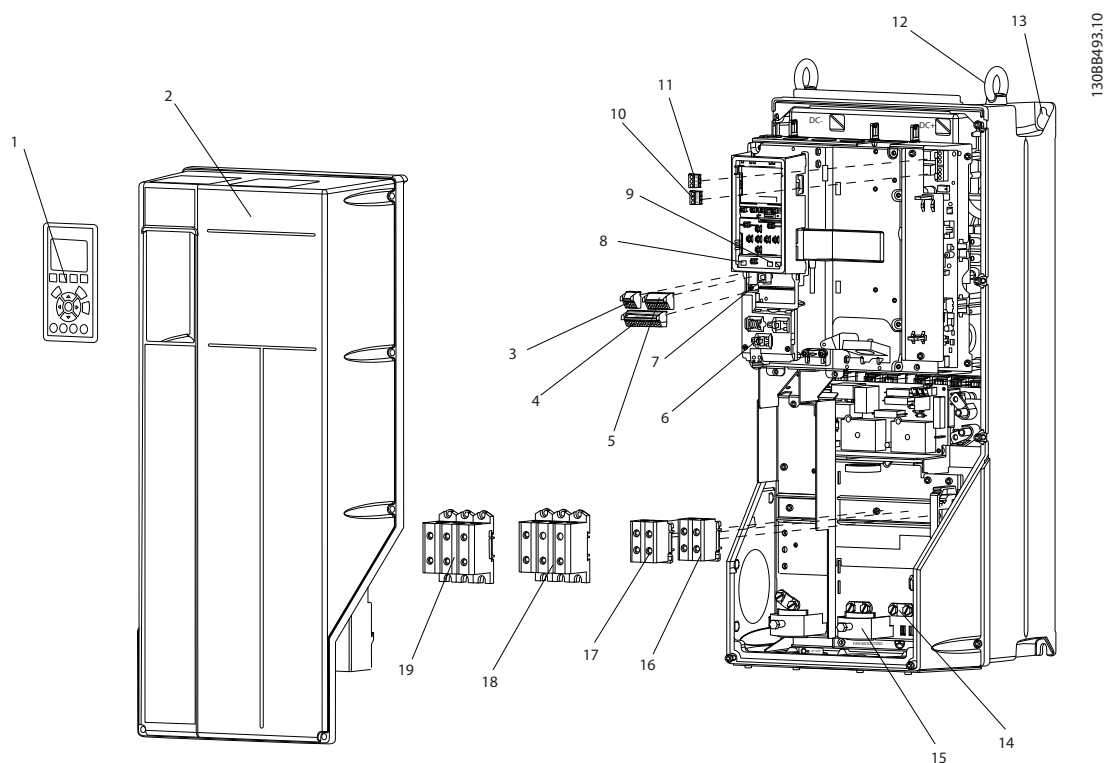

Figure 1.2 Exploded View Frame Sizes B and C

1	LCP	11	Relay 2 (04, 05, 06)
2	Cover	12	Lifting ring
3	RS-485 serial bus connector	13	Mounting slot
4	Digital I/O and 24 V power supply	14	Grounding clamp (PE)
5	Analog I/O connector	15	Cable strain relief/PE ground
6	Cable strain relief/PE ground	16	Brake terminal (-81, +82)
7	USB connector	17	Load sharing terminal (DC bus) (-88, +89)
8	Serial bus terminal switch	18	Motor output terminals 96 (U), 97 (V), 98 (W)
9	Analog switches (A53), (A54)	19	Line power input terminals 91 (L1), 92 (L2), 93 (L3)
10	Relay 1 (01, 02, 03)		

Table 1.2 Legend to Figure 1.2

1.1 Purpose of the Manual

This manual is intended to provide detailed information for the installation and start-up of the adjustable frequency drive. *chapter 2 Installation* provides requirements for mechanical and electrical installation, including input, motor, control and serial communications wiring and control terminal functions. *chapter 3 Start-up and Functional Test* provides detailed procedures for start-up, basic operational programming, and functional testing. The remaining chapters provide supplementary details. These details include user interface, detailed programming, application examples, start-up troubleshooting, and specifications.

1.2 Product Overview

An adjustable frequency drive is an electronic motor controller that converts AC line power input into a variable AC waveform output. The frequency and voltage of the output are regulated to control the motor speed or torque. The adjustable frequency drive can vary the speed of the motor in response to system feedback, such as changing temperature or pressure for controlling fan, compressor, or pump motors. The adjustable frequency drive can also regulate the motor by responding to remote commands from external controllers.

In addition, the adjustable frequency drive monitors the system and motor status, issues warnings or alarms for fault conditions, starts and stops the motor, optimizes energy efficiency, and offers many more control, monitoring, and efficiency functions. Operation and monitoring functions are available as status indications to an outside control system or serial communication network.

1.3 Internal Adjustable Frequency Drive Controller Functions

Figure 1.3 is a block diagram of the adjustable frequency drive's internal components. See Table 1.3 for their functions.

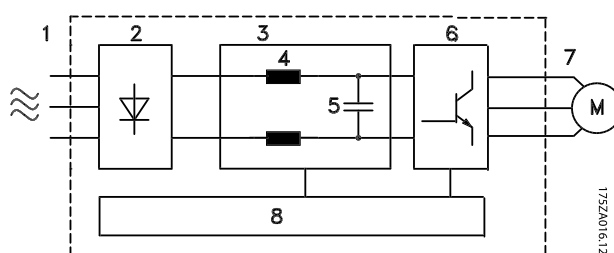

Figure 1.3 Adjustable Frequency Drive Block Diagram

Area	Title	Functions
1	Line power input	<ul style="list-style-type: none"> Three-phase AC line power supply to the adjustable frequency drive
2	Rectifier	<ul style="list-style-type: none"> The rectifier bridge converts the AC input to DC current to supply inverter power
3	DC bus	<ul style="list-style-type: none"> Intermediate DC bus circuit handles the DC current
4	DC reactors	<ul style="list-style-type: none"> Filter the intermediate DC circuit voltage Provide line transient protection Reduce RMS current Raise the power factor reflected back to the line Reduce harmonics on the AC input
5	Capacitor bank	<ul style="list-style-type: none"> Stores the DC power Provides ride-through protection for short power losses
6	Inverter	<ul style="list-style-type: none"> Converts the DC into a controlled PWM AC waveform for a controlled variable output to the motor
7	Output to motor	<ul style="list-style-type: none"> Regulated three-phase output power to the motor

Area	Title	Functions
8	Control circuitry	<ul style="list-style-type: none"> • Input power, internal processing, output, and motor current are monitored to provide efficient operation and control • User interface and external commands are monitored and performed • Status output and control can be provided

Table 1.3 Legend to Figure 1.3

1.4 Frame Sizes and Power Ratings

[V]	Frame Size (hp [kW])											
	A2	A3	A4	A5	B1	B2	B3	B4	C1	C2	C3	C4
200–240	1.5–3 [1.1–2.2]	4–5 [3.0–3.7]	1.5–3 [1.1–2.2]	1.5–5 [1.1–3.7]	7.5–15 [5.5–11]	20 [15]	7.5–15 [5.5–11]	20–25 [15–18.5]	25–40 [18.5–30]	50–60 [37–45]	30–40 [22–30]	50–60 [37–45]
380–480	1.5–5 [1.1–4.0]	7.5–10 [5.5–7.5]	1.5–5 [1.1–4.0]	1.5–10 [1.1–7.5]	15–25 [11–18.5]	30–40 [22–30]	15–25 [11–18.5]	30–50 [22–37]	50–75 [37–55]	100–125 [75–90]	60–75 [45–55]	100–125 [75–90]
525–600	N/A	1.5–10 [1.1–7.5]	N/A	1.5–10 [1.1–7.5]	15–25 [11–18.5]	30–40 [22–30]	15–25 [11–18.5]	30–50 [22–37]	50–75 [37–55]	100–125 [75–90]	60–75 [45–55]	100–125 [75–90]

Table 1.4 Frame Sizes and Power Ratings

2 Installation

2

2.1 Installation Site Checklist

- The adjustable frequency drive relies on the ambient air for cooling. Observe the limitations on ambient air temperature for optimal operation.
- Ensure that the installation location has sufficient support strength to mount the adjustable frequency drive.
- Keep the adjustable frequency drive interior free from dust and dirt. Ensure that the components stay as clean as possible. In construction areas, provide a protective covering. Optional IP55 (TYPE 12) or IP66 (NEMA 4) enclosures may be necessary.
- Keep the manual, drawings, and diagrams accessible for detailed installation and operation instructions. It is important that the manual is available for equipment operators.
- Locate equipment as near to the motor as possible. Keep motor cables as short as possible. Check the motor characteristics for actual tolerances. Do not exceed
 - 300 m (1,000 ft) for unshielded motor leads.
 - 150 m (500 ft) for shielded cable.

2.2 Pre-installation Checklist

- Compare the model number of unit on the nameplate to what was ordered to verify the proper equipment.
- Ensure each of the following are rated for the same voltage:
 - Line power
 - Adjustable frequency drive
 - Motor
- Ensure that the adjustable frequency drive output current rating is equal to or greater than motor full load current for peak motor performance.
 - Motor size and adjustable frequency drive power must match for proper overload protection
 - If adjustable frequency drive rating is less than motor, full motor output cannot be achieved

2.3 Mechanical Installation

2.3.1 Cooling

- To provide cooling airflow, mount the unit to a solid flat surface or to the optional backplate (see *chapter 2.3.3 Mounting*)
- Top and bottom clearance for air cooling must be provided. Generally, 100–225 mm (4–10 in) is required. See *Figure 2.1* for clearance requirements
- Improper mounting can result in overheating and reduced performance
- Derating for temperatures starting between 104 °F [40 °C] and 122 °F [50 °C] and elevation 3300 ft [1000 m] above sea level must be considered. See the equipment Design Guide for detailed information

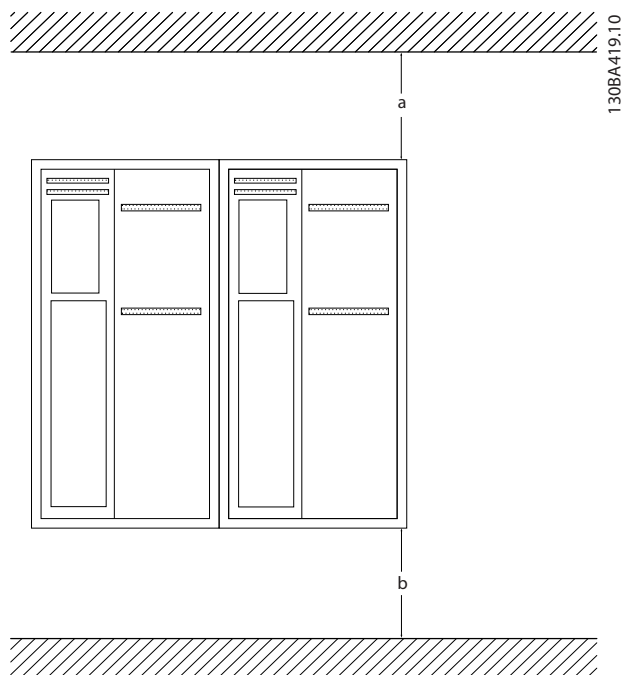

Figure 2.1 Top and Bottom Cooling Clearance

Enclosure	A2-A5	B1-B4	C1, C3	C2, C4
a/b (inch [mm])	100	200	200	225

Table 2.1 Minimum Airflow Clearance Requirements

2.3.2 Lifting

- Check the weight of the unit to determine a safe lifting method
- Ensure that the lifting device is suitable for the task
- If necessary, plan for a hoist, crane, or forklift with the appropriate rating to move the unit
- For lifting, use hoist rings on the unit, where provided

2.3.3 Mounting

- Mount the unit vertically.
- The adjustable frequency drive allows side by side installation.
- Ensure that the strength of the mounting location will support the unit weight.
- Mount the unit onto a solid flat surface or onto the optional backplate to provide cooling airflow (see *Figure 2.2* and *Figure 2.3*).
- Improper mounting can result in overheating and reduced performance.
- Use the slotted mounting holes on the unit for wall mounting, when provided.

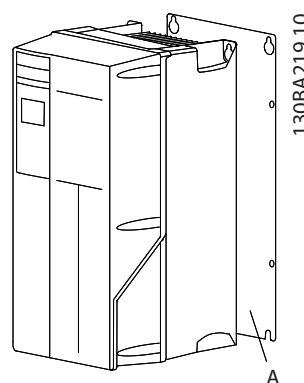

Figure 2.2 Proper Mounting with Backplate

Item A in *Figure 2.2* and *Figure 2.3* is a backplate properly installed for required airflow to cool the unit.

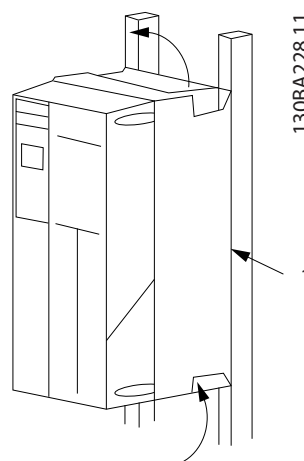

Figure 2.3 Proper Mounting with Railings

NOTICE!

Backplate is needed when mounted on railings.

2

2.3.4 Tightening Torques

See *chapter 10.4 Connection Tightening Torques* for proper tightening specifications.

2.4 Electrical Installation

This section contains detailed instructions for wiring the adjustable frequency drive. The following tasks are described:

- Wiring the motor to the adjustable frequency drive output terminals
- Wiring the AC line power to the adjustable frequency drive input terminals
- Connecting control and serial communication wiring
- After power has been applied, checking input and motor power; programming control terminals for their intended functions

Figure 2.4 shows a basic electrical connection.

2

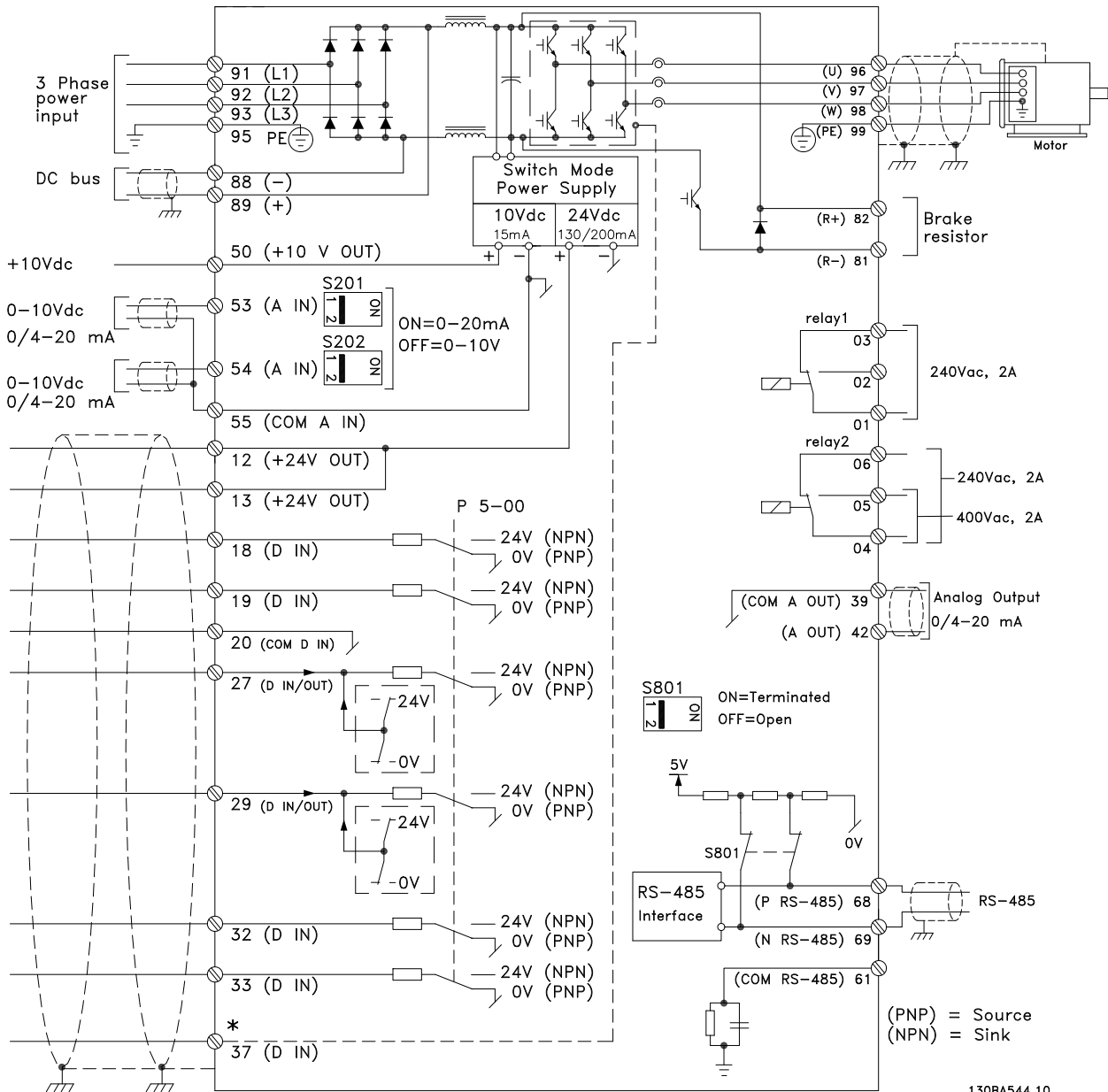
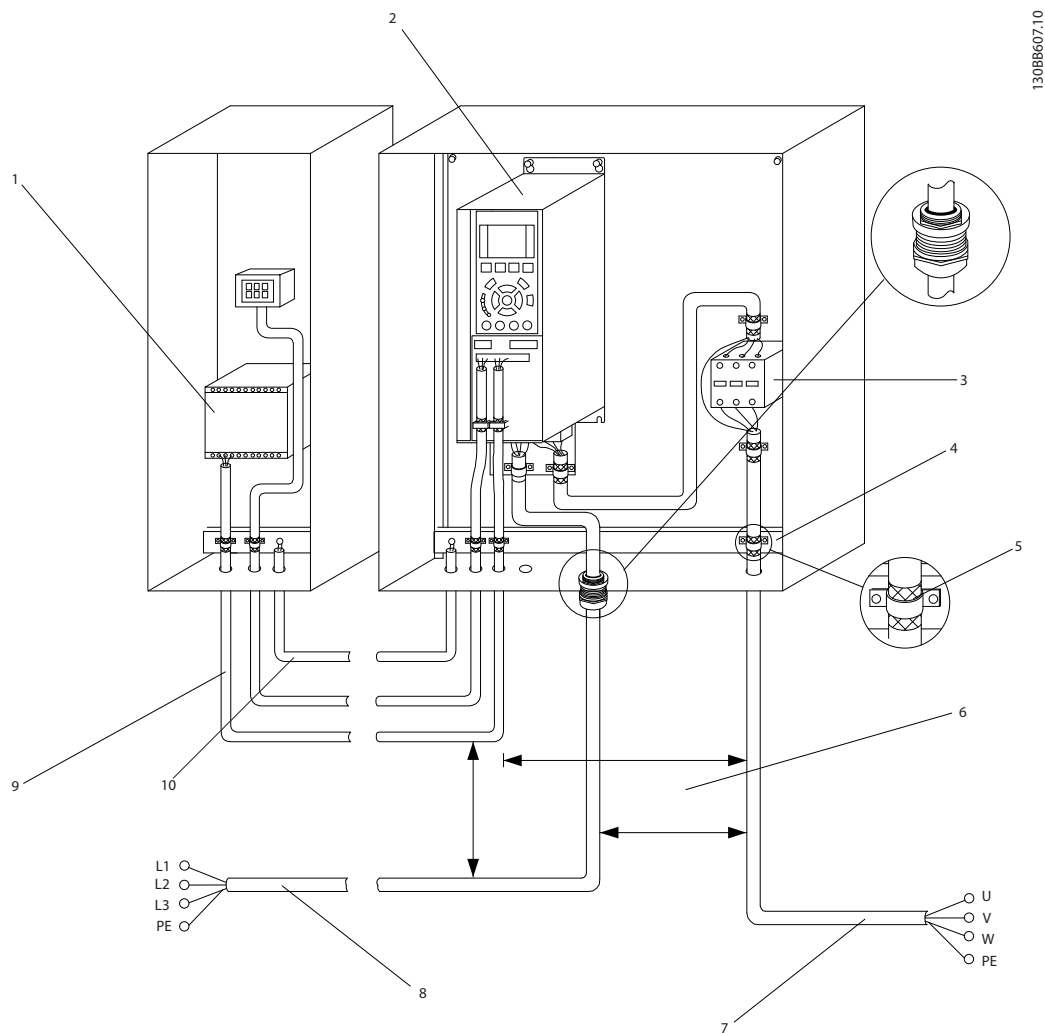

Figure 2.4 Basic Wiring Schematic Drawing

NOTICE!

For additional information, see *Table 2.5*.

2



1308B607.10

Figure 2.5 Typical Electrical Connection

1	PLC	6	Min. 7.9 in [200 mm] between control cables, motor and line power
2	Adjustable frequency drive	7	Motor, 3-phase and PE
3	Output contactor (generally not recommended)	8	Line power, 3-phase and reinforced PE
4	Grounding rail (PE)	9	Control wiring
5	Cable insulation (stripped)	10	Equalizing min. 0.025 in ² [16 mm ²]

Table 2.2

NOTICE!

Use min. 0.016 in² [10 mm²] cables for optimal EMC.

2.4.1 Requirements

⚠ WARNING

EQUIPMENT HAZARD!

Rotating shafts and electrical equipment can be hazardous. All electrical work must conform to national and local electrical codes. It is strongly recommended that installation, start-up, and maintenance be performed only by trained and qualified personnel. Failure to follow these guidelines could result in death or serious injury.

CAUTION

WIRING ISOLATION!

Run input power, motor wiring and control wiring in three separate metallic conduits or use separated shielded cable for high frequency noise isolation. Failure to isolate power, motor and control wiring could result in less than optimum adjustable frequency drive and associated equipment performance.

For your safety, comply with the following requirements.

- Electronic controls equipment is connected to hazardous AC line voltage. Extreme care should be taken to protect against electrical hazards when applying power to the unit.
- Run motor cables from multiple adjustable frequency drives separately. Induced voltage from output motor cables run together can charge equipment capacitors even with the equipment turned off and locked out.

Overload and Equipment Protection

- An electronically activated function within the adjustable frequency drive provides overload protection for the motor. The overload calculates the level of increase to activate timing for the trip (controller output stop) function. The higher the current draw, the quicker the trip response. The overload provides Class 20 motor protection. See *chapter 8 Warnings and Alarms* for details on the trip function.

- Because the motor wiring carries high frequency current, it is important that wiring for line power, motor power, and control is run separately. Use metallic conduit or separated shielded wire. Failure to isolate power, motor, and control wiring could result in less than optimum equipment performance. See *Figure 2.6*.

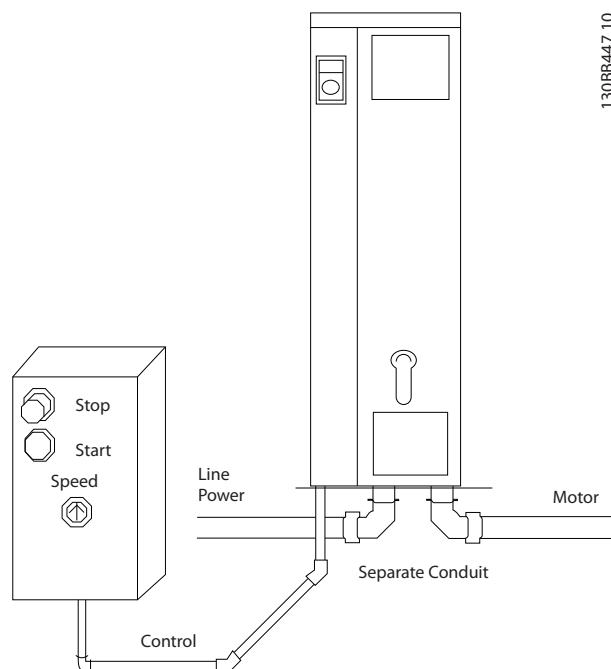

Figure 2.6 Proper Electrical Installation Using Conduit

- All adjustable frequency drives must be provided with short-circuit and overcurrent protection. Input fusing is required to provide this protection, see *Figure 2.7*. If not factory supplied, fuses must be provided by the installer as part of installation. See maximum fuse ratings in *chapter 10.1 Power-dependent Specifications*.

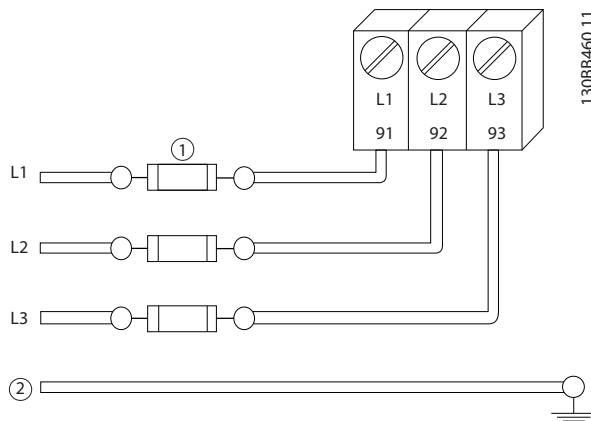

Figure 2.7 Adjustable Frequency Drive Fuses

Wire Type and Ratings

- All wiring must comply with local and national regulations regarding cross-section and ambient temperature requirements.
- Danfoss recommends that all power connections be made with a minimum 167 °F [75 °C] rated copper wire.
- See *chapter 10.1 Power-dependent Specifications* for recommended wire sizes.

2.4.2 Grounding Requirements**⚠ WARNING****GROUNDING HAZARD!**

For operator safety, it is important to ground the adjustable frequency drive properly in accordance with national and local electrical codes as well as instructions contained within this document. Ground currents are higher than 3.5 mA. Failure to ground the adjustable frequency drive properly could result in death or serious injury.

NOTICE

It is the responsibility of the user or certified electrical installer to ensure correct grounding of the equipment in accordance with national and local electrical codes and standards.

- Follow all local and national electrical codes to ground electrical equipment properly
- Proper protective grounding for equipment with ground currents higher than 3.5 mA must be established, see *chapter 2.4.2.1 Leakage Current (>3.5 mA)*
- A dedicated ground wire is required for input power, motor power and control wiring
- Use the clamps provided with the equipment for proper ground connections
- Do not ground one adjustable frequency drive to another in a "daisy chain" fashion
- Keep the ground wire connections as short as possible
- Using high-strand wire to reduce electrical noise is recommended
- Follow the motor manufacturer wiring requirements

2.4.2.1 Leakage Current (>3.5 mA)

Follow national and local codes regarding protective grounding of equipment with a leakage current > 3.5 mA. Adjustable frequency drive technology implies high frequency switching at high power. This will generate a leakage current in the ground connection. A fault current in the adjustable frequency drive at the output power terminals might contain a DC component which can charge the filter capacitors and cause a transient ground current. The ground leakage current depends on various system configurations including RFI filtering, shielded motor cables, and adjustable frequency drive power.

EN/IEC61800-5-1 (Power Drive System Product Standard) requires special care if the leakage current exceeds 3.5 mA. Grounding must be reinforced in one of the following ways:

- Ground wire of at least 0.0155 in² [10 mm²]
- Two separate ground wires both complying with the dimensioning rules

See EN 60364-5-54 § 543.7 for further information.

Using RCDs

Where residual current devices (RCDs), also known as ground leakage circuit breakers (GLCBs), are used, comply with the following:

- Use RCDs of type B only which are capable of detecting AC and DC currents
- Use RCDs with an inrush delay to prevent faults due to transient ground currents
- Dimension RCDs according to the system configuration and environmental considerations

2.4.2.2 Grounding Using Shielded Cable

Grounding clamps are provided for motor wiring (see Figure 2.8).

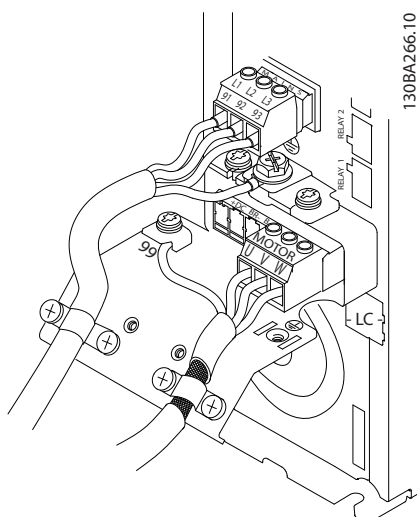

Figure 2.8 Grounding with Shielded Cable

2.4.3 Access

CAUTION

Device damage through contamination
Do not leave the adjustable frequency drive uncovered.

- Remove access cover plate with a screwdriver. See Figure 2.9.
- Or remove front cover by loosening attaching screws. See Figure 2.10.

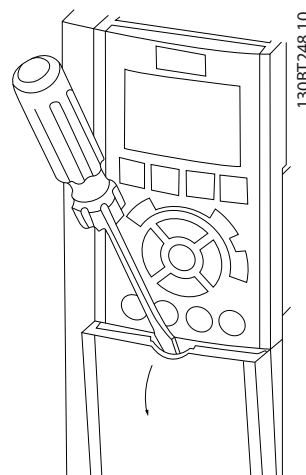

Figure 2.9 Control Wiring Access for A2, A3, B3, B4, C3 and C4 Enclosures

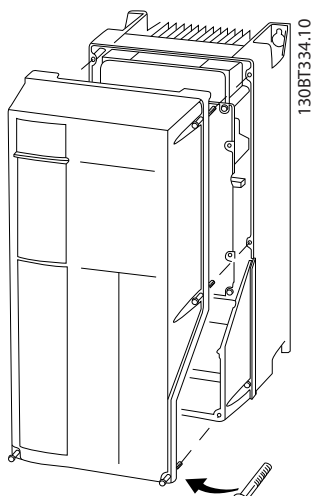

Figure 2.10 Control Wiring Access for A4, A5, B1, B2, C1 and C2 Enclosures

See Table 2.3 before tightening the covers.

Frame	IP20	IP21	IP55	IP66
A4/A5	-	-	2	2
B1	-	*	2.2	2.2
B2	-	*	2.2	2.2
C1	-	*	2.2	2.2
C2	-	*	2.2	2.2

* No screws to tighten
 - Does not exist

Table 2.3 Tightening Torques for Covers (Nm)

2.4.4 Motor Connection

⚠ WARNING

INDUCED VOLTAGE!

Run output motor cables from multiple adjustable frequency drives separately. Induced voltage from output motor cables run together can charge equipment capacitors even with the equipment turned off and locked out. Failure to run output motor cables separately could result in death or serious injury.

- For maximum wire sizes, see *chapter 10.1 Power-dependent Specifications*
- Comply with local and national electrical codes for cable sizes
- Motor wiring knockouts or access panels are provided at the base of IP21 and higher (NEMA1/12) units

- Do not install power factor correction capacitors between the adjustable frequency drive and the motor
- Do not wire a starting or pole-changing device between the adjustable frequency drive and the motor
- Connect the 3-phase motor wiring to terminals 96 (U), 97 (V), and 98 (W)
- Ground the cable in accordance with grounding instructions provided
- Torque terminals in accordance with the information provided in *chapter 10.4 Connection Tightening Torques*
- Follow the motor manufacturer wiring requirements

Figure 2.11, Figure 2.12 and Figure 2.13 represent line power input, motor, and grounding for basic adjustable frequency drives. Actual configurations vary with unit types and optional equipment.

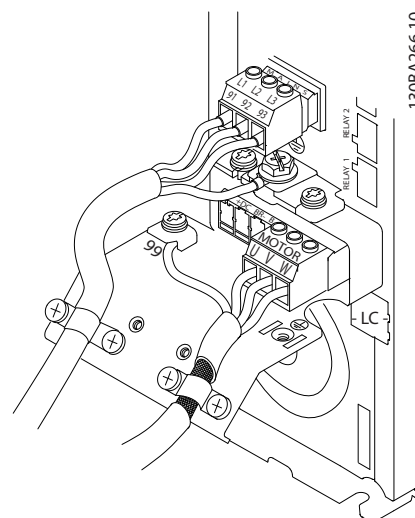
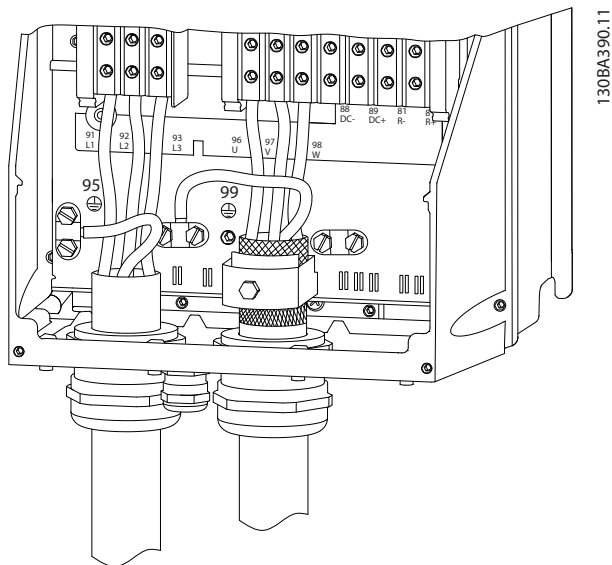
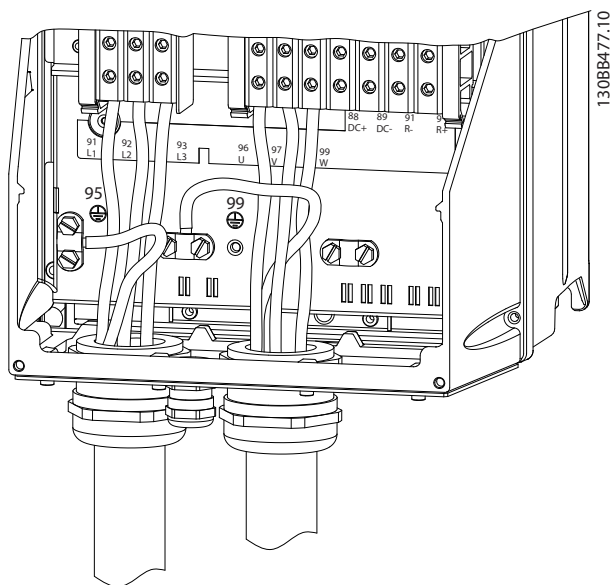

Figure 2.11 Motor, Line Power and Ground Wiring for Frame Size A



130BA390.11

Figure 2.12 Motor, Line Power and Ground Wiring for Frame Sizes B, C and D Using Shielded Cable



130BB477.10

Figure 2.13 Motor, Line Power and Ground Wiring for Frame Sizes B, C and D Using Conduit

2.4.4.1 Motor Connection for A2 and A3

Follow these drawings step-by-step for connecting the motor to the adjustable frequency drive.

1. Terminate the motor ground, place motor U, V and W wires in plug and tighten.

2

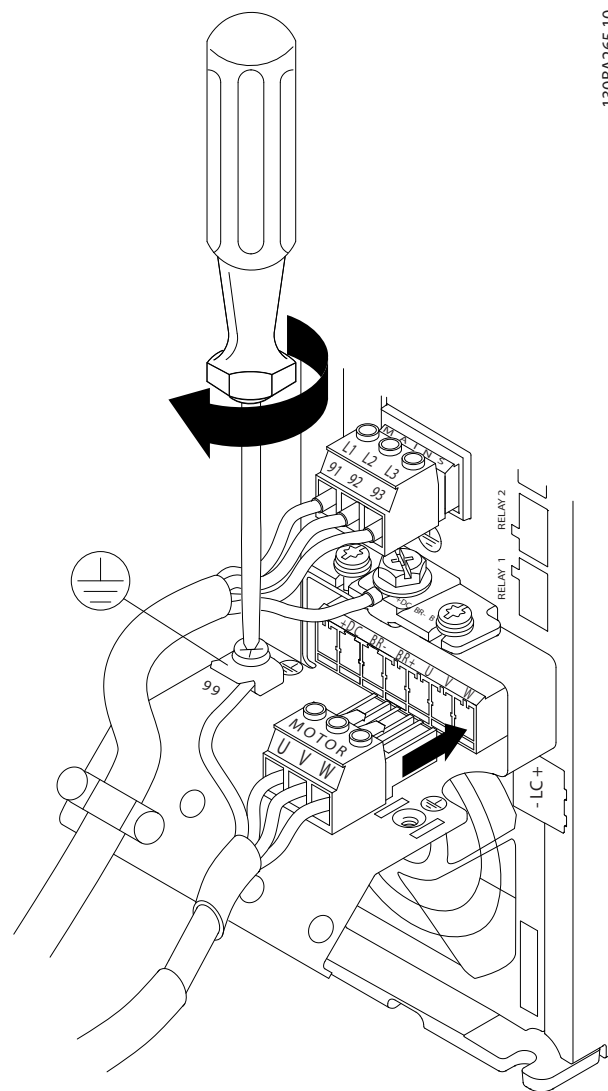

130BA265.10

Figure 2.14 Motor Connection for A2 and A3

2

2. Mount cable clamp to ensure 360° connection between chassis and shield, note the outer insulation of the motor cable is removed under the clamp.

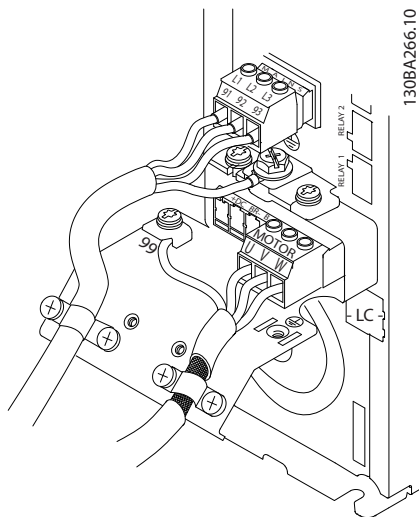

Figure 2.15 Cable Clamp Mounting

2.4.4.2 Motor Connection for A4 and A5

1. Terminate the motor ground
2. Place motor U, V and W wires in terminal and tighten
3. Ensure that the outer insulation of the motor cable is removed under the EMC clamp

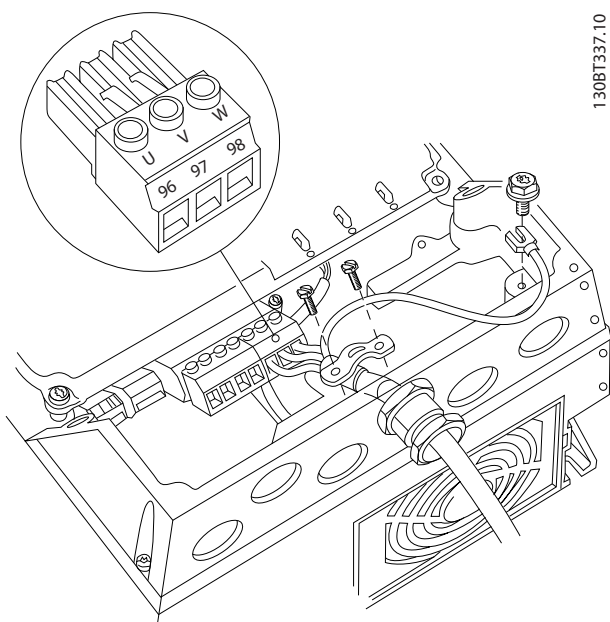

Figure 2.16 Motor Connection for A4 and A5

2.4.4.3 Motor Connection for B1 and B2

1. Terminate the motor ground
2. Place motor U, V and W wires in terminal and tighten
3. Ensure that the outer insulation of the motor cable is removed under the EMC clamp

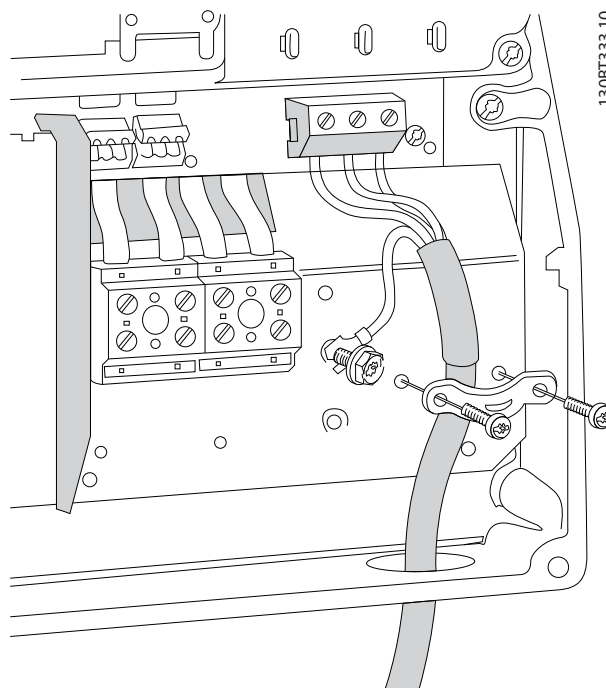

Figure 2.17 Motor Connection for B1 and B2

2.4.4.4 Motor Connection for C1 and C2

1. Terminate the motor ground
2. Place motor U, V and W wires in terminal and tighten
3. Ensure that the outer insulation of the motor cable is removed under the EMC clamp

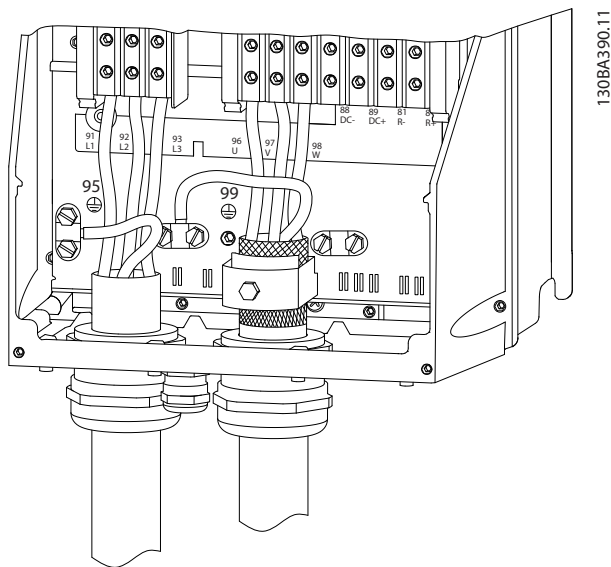

Figure 2.18 Motor Connection for C1 and C2

2.4.5 AC Line Power Connection

- Size wiring based upon the input current of the adjustable frequency drive. For maximum wire sizes, see *chapter 10.1 Power-dependent Specifications*.
- Comply with local and national electrical codes for cable sizes.
- Connect 3-phase AC input power wiring to terminals L1, L2, and L3 (see *Figure 2.19*).
- Depending on the configuration of the equipment, input power will be connected to the line power input terminals or the input disconnect.

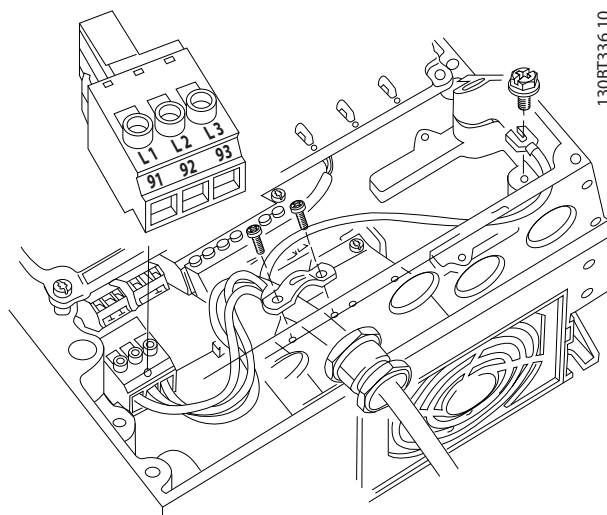

Figure 2.19 Connecting to AC Line Power

- Ground the cable in accordance with grounding instructions provided in *chapter 2.4.2 Grounding Requirements*.
- All adjustable frequency drives may be used with an isolated input source as well as with ground reference power lines. When supplied from an isolated line power source (IT line power or floating delta) or TT/TN-S line power with a grounded leg (grounded delta), set *14-50 RFI 1* to [0] Off. When off, the internal RFI filter capacitors between the chassis and the intermediate circuit are isolated to avoid damage to the intermediate circuit and to reduce ground capacity currents in accordance with IEC 61800-3.

2

2.4.5.1 AC Line Input Connection for A2 and A3

1. Mount the two screws on the mounting plate
2. Slide the mounting plate into place and tighten fully

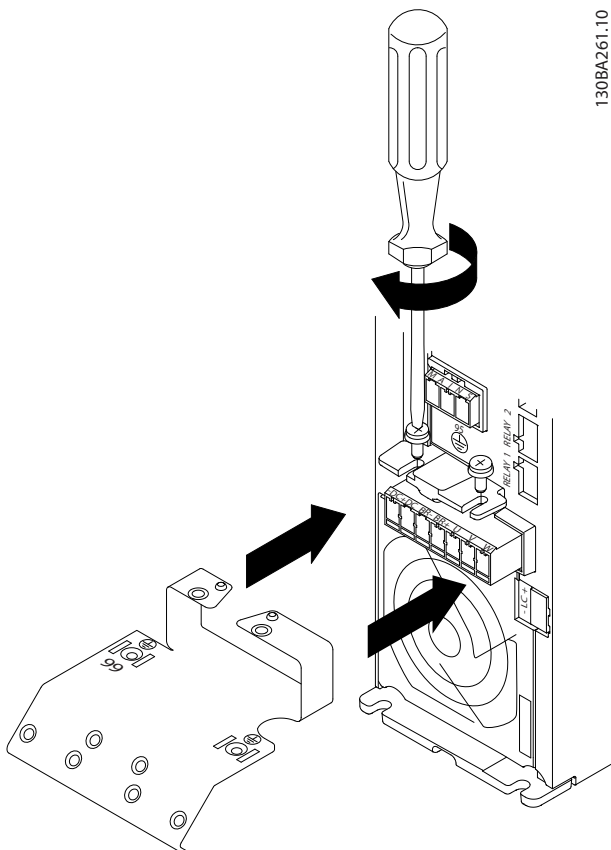

Figure 2.20 Mounting Plate Position

3. Mount and tighten ground cable

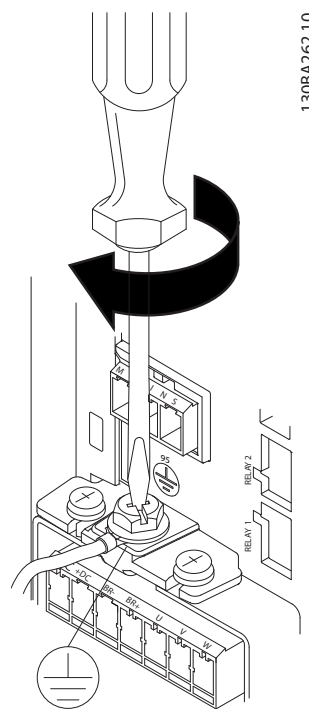

Figure 2.21 Ground Cable Mounting

⚠ WARNING

The ground connection cable cross-section must be at least 0.016 in² [10 mm²] or two rated line power wires terminated separately according to EN 50178/IEC 61800-5-1.

4. Mount line power plug and tighten wires

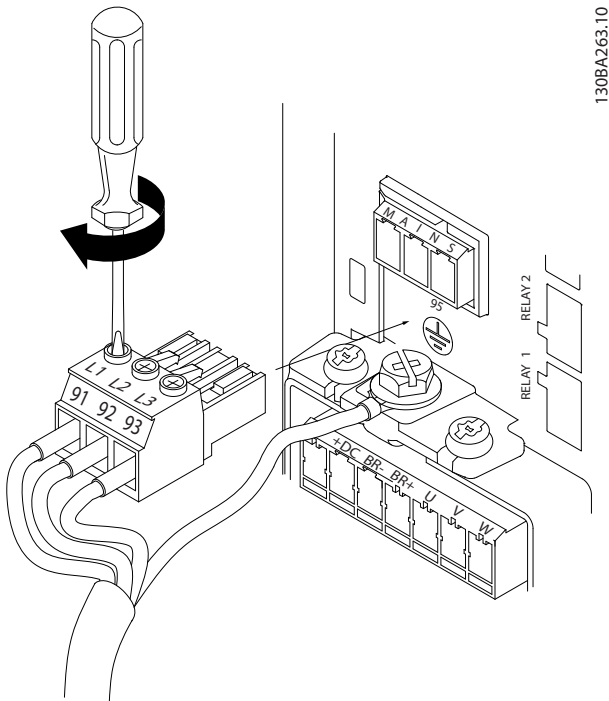

Figure 2.22 Line Power Plug Mounting

2.4.5.2 AC Line Input Connection for A4 and A5

NOTICE!

A cable clamp is used.

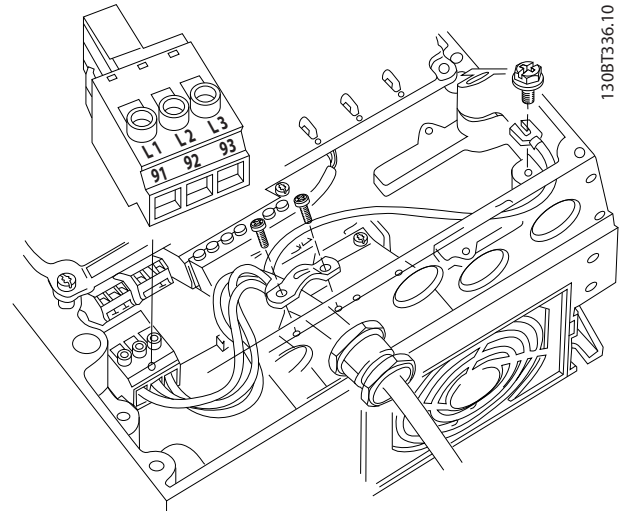

Figure 2.24 Connection to Line Power and Grounding without Line Power Disconnect Switch

5. Tighten support bracket on line power wires

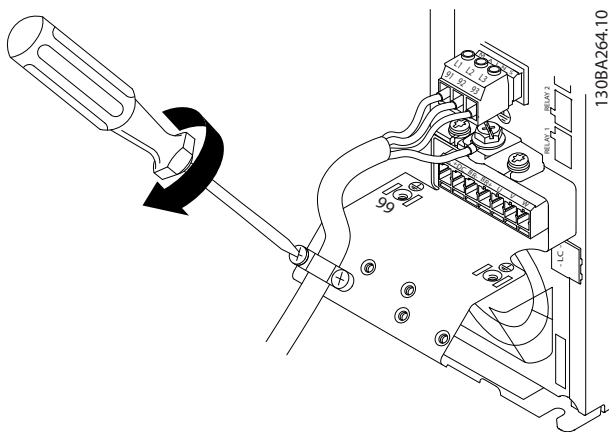

Figure 2.23 Support Bracket Mounting

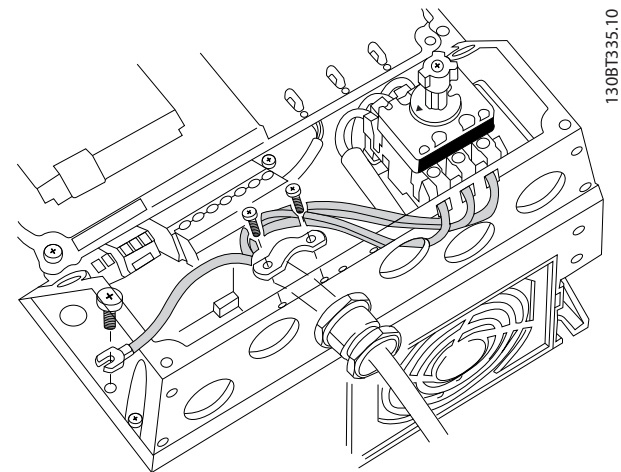

Figure 2.25 Connection to Line Power and Grounding with Line Power Disconnect Switch

2

2.4.5.3 AC Line Input Connection for B1 and B2

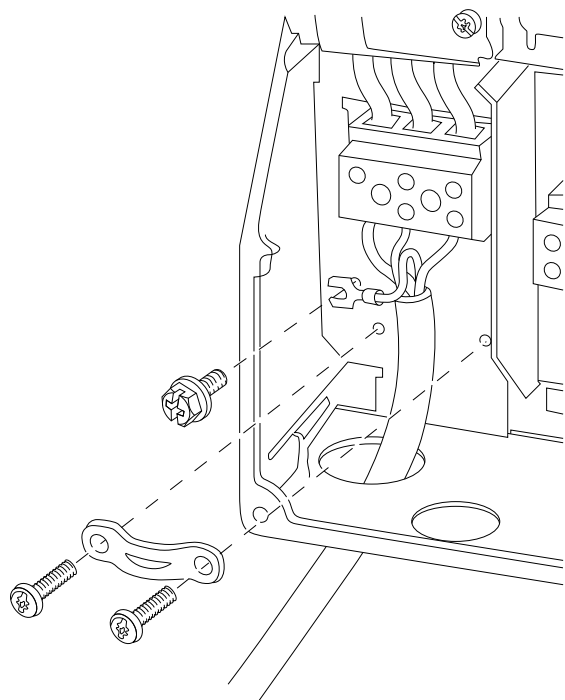

Figure 2.26 Connection to Line Power and Grounding for B1 and B2

NOTICE!

For correct cable dimensions, see *chapter 10.2 General Technical Data*.

2.4.5.4 AC Line Input Connection for C1 and C2

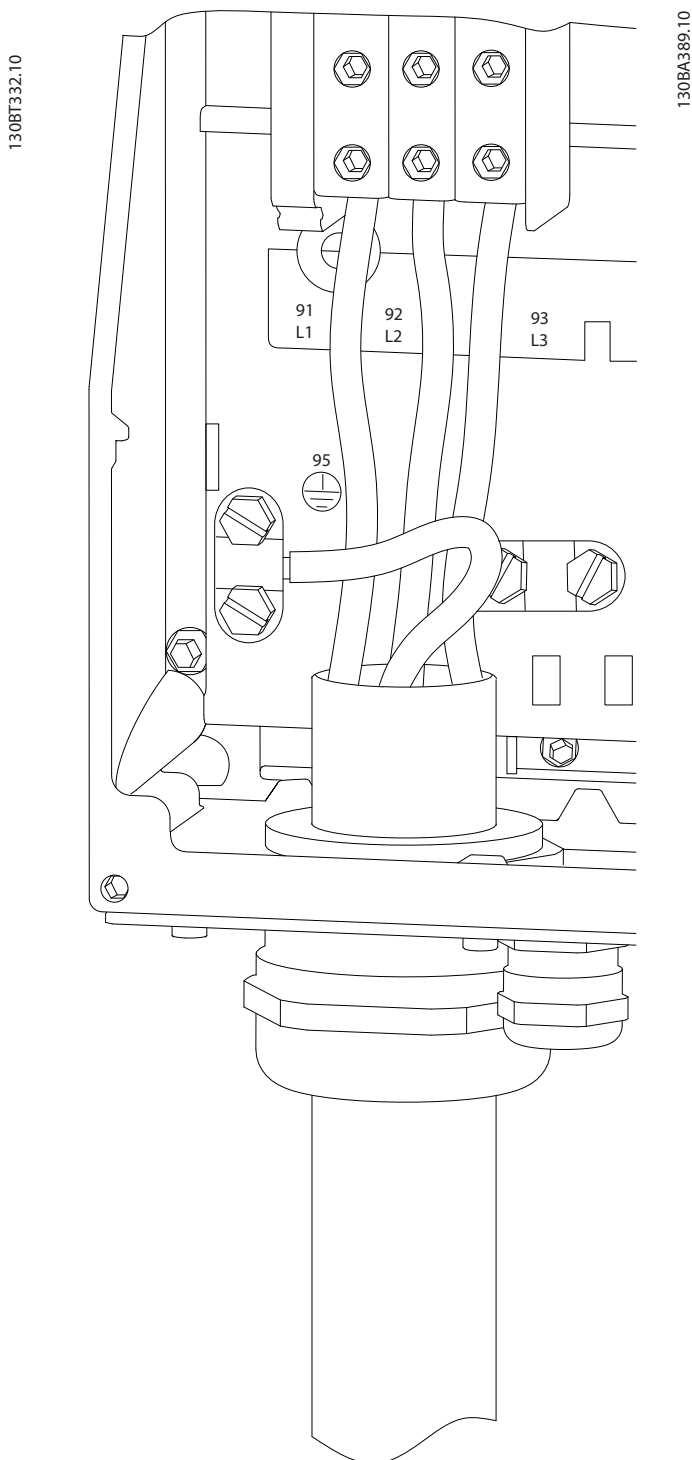

Figure 2.27 Connection to Line Power and Grounding for C1 and C2

2.4.6 Control Wiring

2.4.6.1 Control Terminal Types

Figure 2.28 shows the removable adjustable frequency drive connectors. Terminal functions and default settings are summarized in Table 2.5.

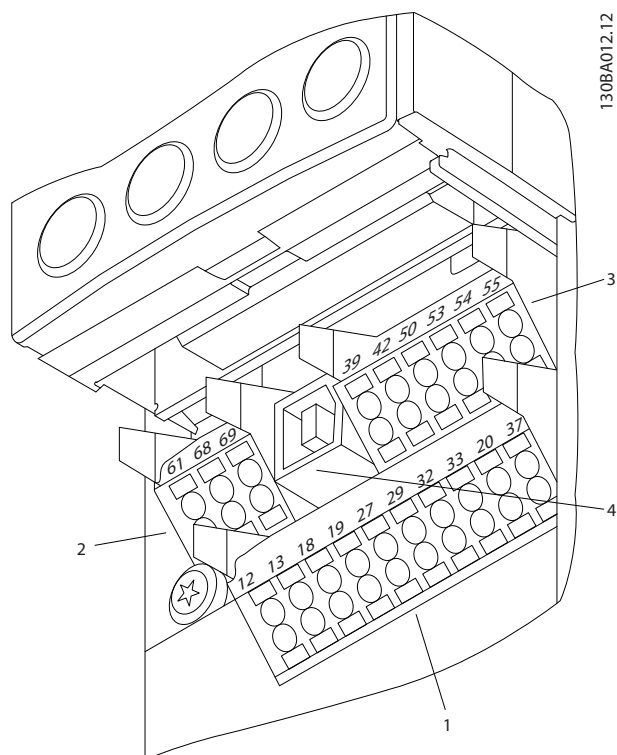

Figure 2.28 Control Terminal Locations

1	Connector 1: Terminals 12-37
2	Connector 2: Terminals 61-69
3	Connector 3: Terminals 39-55
4	Connector 4: Terminals 1-6

Table 2.4 Legend to Figure 2.28

- **Connector 1** provides four programmable digital inputs terminals, two additional digital terminals programmable as either input or output, a 24 V DC terminal supply voltage, and a common for optional customer supplied 24 V DC voltage
- **Connector 2** terminals (+)68 and (-)69 are for an RS-485 serial communications connection
- **Connector 3** provides two analog inputs, one analog output, 10 V DC supply voltage, and commons for the inputs and output
- **Connector 4** is a USB port available for use with the adjustable frequency drive

- Also provided are two Form C relay outputs that are in various locations depending upon the adjustable frequency drive configuration and size
- Some options available for ordering with the unit may provide additional terminals. See the manual provided with the equipment option

See chapter 10.2 General Technical Data for terminal ratings details.

Digital Inputs/Outputs			
Terminal	Parameter	Default Setting	Description
12, 13	-	+24 V DC	24 V DC supply voltage. Maximum output current is 200 mA total for all 24 V loads. Usable for digital inputs and external transducers.
18	5-10	[8] Start	Digital inputs.
19	5-11	[10] Reversing	
32	5-14	[39] Day/Night Control	
33	5-15	[0] No operation	
27	5-12	[2] Coast inverse	Selectable for either digital input or output. Default setting is input.
29	5-13	[0] No operation	
20	-		Common for digital inputs and 0 V potential for 24 V supply.
37	-	Safe Torque Off (STO)	(Optional) Safe input. Used for STO.
Analog Inputs/Outputs			
39	-		Common for analog output.
42	6-50	[100] Output frequency	Programmable analog output. The analog signal is 0–20 mA or 4–20 mA at a maximum of 500 Ω..
50	-	+10 V DC	10 V DC analog supply voltage. 15 mA maximum commonly used for potentiometer or thermistor.
53	6-1*	Reference	Analog input.
54	6-2*	Feedback	Selectable for voltage or current. Switches A53 and A54 select mA or V.

Digital Inputs/Outputs			
Terminal	Parameter	Default Setting	Description
55	-		Common for analog input.
Serial Communication			
61	-		Integrated RC filter for cable screen. ONLY for connecting the shield when experiencing EMC problems.
68 (+)	8-3*		RS-485 Interface. A control card switch is provided for termination resistance.
69 (-)	8-3*		
Relays			
01, 02, 03	5-40	[2] Drive ready	Form C relay output.
04, 05, 06	5-40	[5] Running	Usable for AC or DC voltage and resistive or inductive loads.

Table 2.5 Terminal Description

2.4.6.2 Wiring to Control Terminals

Control terminal connectors can be unplugged from the adjustable frequency drive for ease of installation, as shown in Figure 2.29.

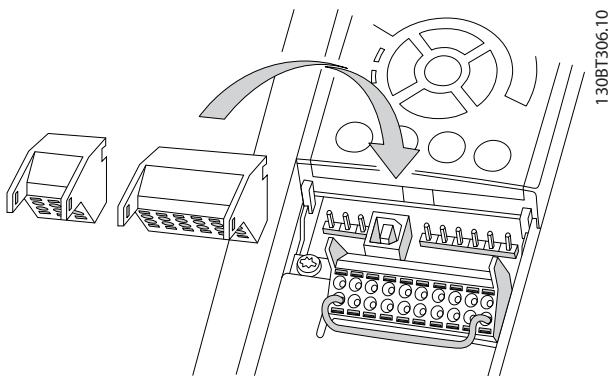

Figure 2.29 Unplugging Control Terminals

1. Open the contact by inserting a small screwdriver into the slot above or below the contact, as shown in Figure 2.30.
2. Insert the bared control wire into the contact.

3. Remove the screwdriver to fasten the control wire into the contact.
4. Ensure the contact is firmly established and not loose. Loose control wiring can be the source of equipment faults or less than optimal operation.

See chapter 10.1 Power-dependent Specifications for control terminal wiring sizes.

See chapter 6 Application Set-up Examples for typical control wiring connections.

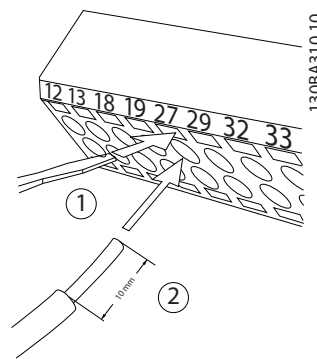

Figure 2.30 Connecting Control Wiring

2.4.6.3 Using Shielded Control Cables

Correct shielding

The preferred method in most cases is to secure control and serial communication cables with shielding clamps provided at both ends to ensure best possible high frequency cable contact.

If the ground potential between the adjustable frequency drive and the PLC is different, electrical noise may occur that will disturb the entire system. Solve this problem by fitting an equalizing cable next to the control cable.

Minimum cable cross-section: 16 mm².

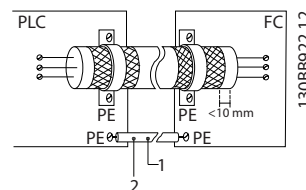

Figure 2.31 Correct Shielding

1	Min. 0.025 in ² [16 mm ²]
2	Equalizing cable

Table 2.6 Legend to Figure 2.31

50/60 Hz ground loops

With very long control cables, ground loops may occur. To eliminate ground loops, connect one end of the shield-to-ground with a 100 nF capacitor (keeping leads short).

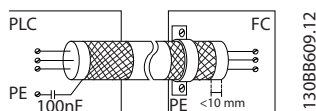

Figure 2.32 50/60 Hz Ground Loops

Avoid EMC noise on serial communication

This terminal is grounded via an internal RC link. Use twisted-pair cables to reduce interference between conductors. The recommended method is shown in Figure 2.33:

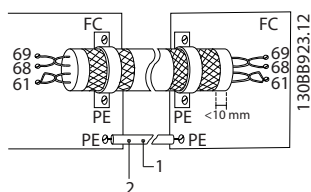

Figure 2.33 Twisted-pair Cables

1	Min. 0.025 in ² [16 mm ²]
2	Equalizing cable

Table 2.7 Legend to Figure 2.33

Alternatively, the connection to terminal 61 can be omitted:

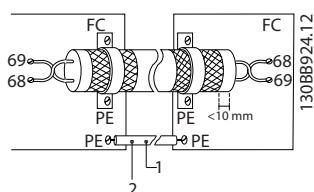

Figure 2.34 Twisted-pair Cables without Terminal 61

1	Min. 0.025 in ² [16 mm ²]
2	Equalizing cable

Table 2.8 Legend to Figure 2.34

2.4.6.4 Jumper Terminals 12 and 27

A jumper wire may be required between terminal 12 (or 13) and terminal 27 for the adjustable frequency drive to operate when using factory default programming values.

- Digital input terminal 27 is designed to receive a 24 V DC external interlock command. In many applications, the user wires an external interlock device to terminal 27.
- When no interlock device is used, wire a jumper between control terminal 12 (recommended) or 13 to terminal 27. This provides an internal 24 V signal on terminal 27.
- No signal present prevents the unit from operating.
- When the status line at the bottom of the LCP reads *AUTO REMOTE COASTING* or *Alarm 60 External Interlock* is displayed, this indicates that the unit is ready to operate but is missing an input signal on terminal 27.
- When factory installed optional equipment is wired to terminal 27, do not remove that wiring.

2.4.6.5 Terminal 53 and 54 Switches

- Analog input terminals 53 and 54 can select either voltage (0 to 10 V) or current (0/4–20 mA) input signals.
- Remove power to the adjustable frequency drive before changing switch positions.
- Set switches A53 and A54 to select the signal type. U selects voltage, I selects current.
- The switches are accessible when the LCP has been removed (see Figure 2.35).

⚠ WARNING

Some option cards available for the unit may cover these switches and must be removed to change switch settings. Always remove power to the unit before removing option cards.

- Terminal 53 default is for a speed reference signal in open-loop set in *16-61 Terminal 53 Switch Setting*
- Terminal 54 default is for a feedback signal in closed-loop set in *16-63 Terminal 54 Switch Setting*

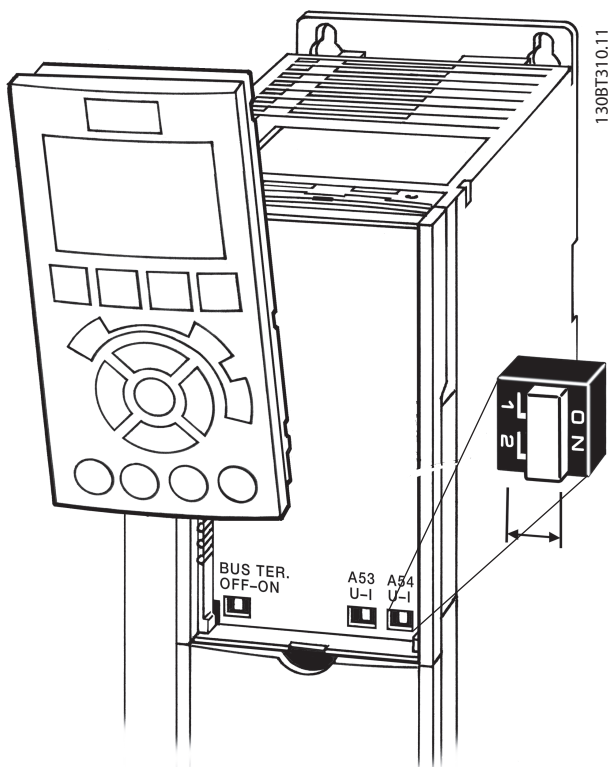

Figure 2.35 Location of Terminals 53 and 54 Switches

2.4.6.6 Terminal 37

Terminal 37 Safe Torque Off (STO) function

The adjustable frequency drive is available with optional STO functionality via control terminal 37. STO disables the control voltage of the power semiconductors of the adjustable frequency drive output stage which in turn prevents generating the voltage required to rotate the motor. When the STO (T37) is activated, the adjustable frequency drive issues an alarm, trips the unit, and coasts the motor to a stop. Manual restart is required. The STO function can be used for stopping the adjustable frequency drive in emergency stop situations. In normal operating mode when STO is not required, use the adjustable frequency drive's regular stop function instead. When automatic restart is used, the requirements according to ISO 12100-2 paragraph 5.3.2.5 must be fulfilled.

Liability conditions

Ensure that personnel installing and operating the STO function:

- Read and understand the safety regulations concerning health and safety/accident prevention
- Understand the generic and safety guidelines given in this description and the extended description in the *Design Guide*
- Have a good knowledge of the generic and safety standards applicable to the specific application

Standards

Use of STO on terminal 37 requires that the user satisfies all provisions for safety including relevant laws, regulations and guidelines. The optional STO function complies with the following standards.

- EN 954-1: 1996 Category 3
- IEC 60204-1: 2005 category 0 – uncontrolled stop
- IEC 61508: 1998 SIL2
- IEC 61800-5-2: 2007 – safe torque off (STO) function
- IEC 62061: 2005 SIL CL2
- ISO 13849-1: 2006 Category 3 PL d
- ISO 14118: 2000 (EN 1037) – prevention of unexpected start-up

The information and instructions in the instruction manual are not sufficient for a proper and safe use of the STO functionality. The related information and instructions in the relevant *Design Guide* must be followed.

Protective measures

- Safety engineering systems may only be installed and commissioned by qualified and skilled personnel
- The unit must be installed in an IP54 cabinet or in an equivalent environment
- The cable between terminal 37 and the external safety device must be short-circuit-protected according to ISO 13849-2 table D.4
- If any external forces influence the motor axis (e.g., suspended loads), additional measures (e.g., a safety holding brake) are required in order to eliminate hazards

STO installation and set-up

WARNING

STO FUNCTION!

The STO function does NOT isolate AC line voltage to the adjustable frequency drive or auxiliary circuits. Perform work on electrical parts of the adjustable frequency drive or the motor only after isolating the AC line voltage and waiting the length of time specified in *chapter 1 Safety*. Failure to isolate the AC line voltage supply from the unit and waiting the time specified could result in death or serious injury.

- It is not recommended to stop the adjustable frequency drive by using the Safe Torque Off function. If a running adjustable frequency drive is stopped by using the function, the unit will trip and stop by coasting. If this is not acceptable, e.g., causes danger, the adjustable frequency drive and machinery must be stopped using the appropriate stopping mode before using this function. Depending on the application, a mechanical brake may be required.
- Concerning synchronous and permanent magnet motor adjustable frequency drives in case of a multiple IGBT power semiconductor failure: In spite of the activation of the Safe Torque Off function, the adjustable frequency drive system can produce an alignment torque which maximally rotates the motor shaft by 180/p degrees. p denotes the pole pair number.
- This function is suitable for performing mechanical work on the adjustable frequency drive system or affected area of a machine only. It does not provide electrical safety. This function should not be used as a control for starting and/or stopping the adjustable frequency drive.

The following requirements have to be met to perform a safe installation of the adjustable frequency drive:

1. Remove the jumper wire between control terminals 37 and 12 or 13. Cutting or breaking the jumper is not sufficient to avoid short-circuiting. (See jumper in *Figure 2.36*).
2. Connect an external safety monitoring relay via a NO safety function (the instruction for the safety device must be followed) to terminal 37 (STO) and either terminal 12 or 13 (24 V DC). The safety monitoring relay must comply with Category 3 (EN 954-1) / PL "d" (ISO 13849-1).

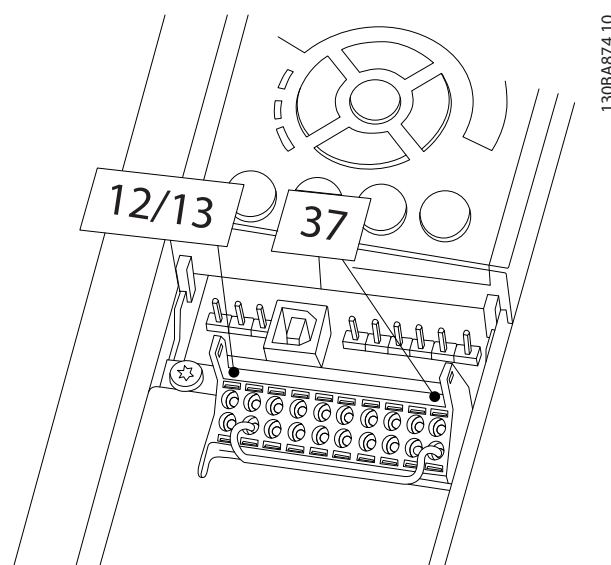
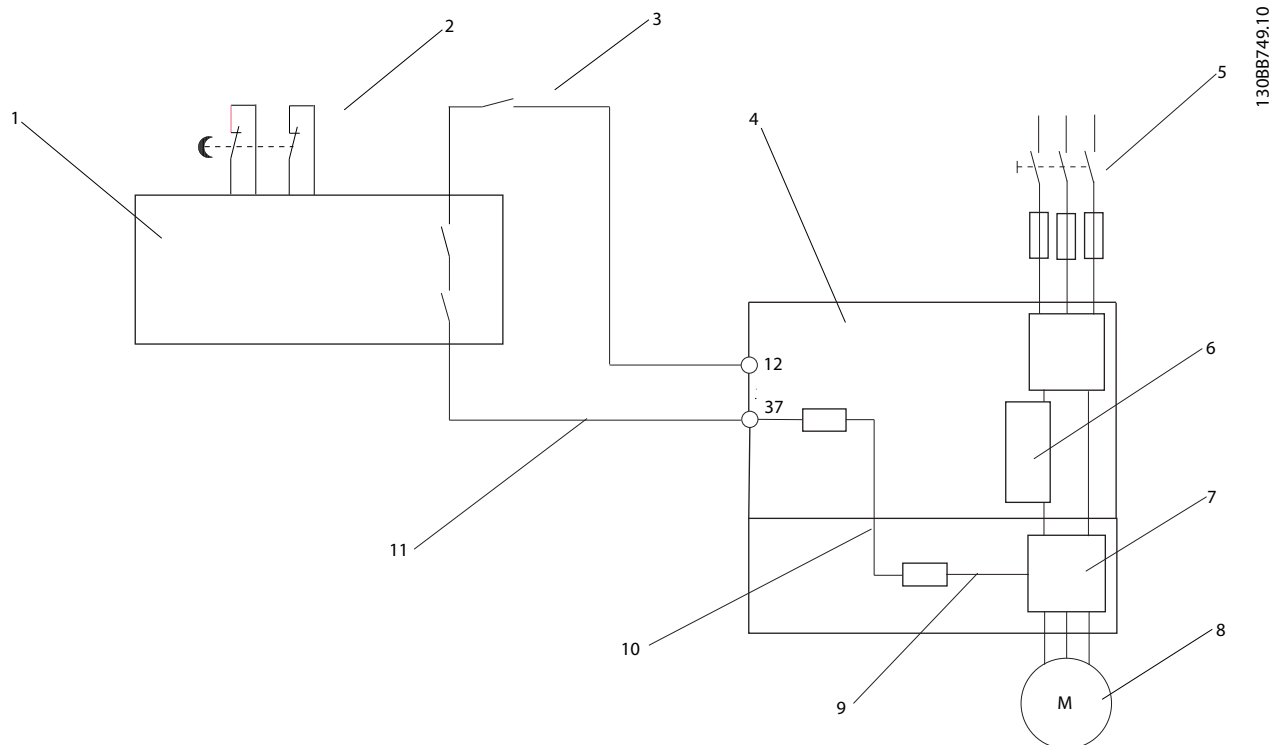

Figure 2.36 Jumper between Terminal 12/13 (24 V) and 37

130BA874.10



130BB749.10

Figure 2.37 Installation to Achieve a Stopping Category 0 (EN 60204-1) with Safety Cat. 3 (EN 954-1) / PL "d" (ISO 13849-1).

1	Safety device Cat. 3 (circuit interrupt device, possibly with release input)	7	Inverter
2	Door contact	8	Motor
3	Contactora (Coast)	9	5 V DC
4	Adjustable frequency drive	10	Safe channel
5	Line power	11	Short-circuit protected cable (if not inside installation cabinet)
6	Control board		

Table 2.9 Legend to Figure 2.37

STO commissioning test

After installation and before first operation, perform a commissioning test of the installation making use of STO. Also, perform the test after each modification of the installation.

2.4.7 Serial Communication

RS-485 is a two-wire bus interface compatible with multi-drop network topology, i.e., nodes can be connected as a bus, or via drop cables from a common trunk line. A total of 32 nodes can be connected to one network segment. Repeaters divide network segments. Note that each repeater functions as a node within the segment in which it is installed. Each node connected within a given network must have a unique node address across all segments. Terminate each segment at both ends using either the termination switch (S801) of the adjustable frequency drives or a biased termination resistor network. Always use shielded twisted pair (STP) cable for bus cabling, and always follow good common installation practice. Low-impedance ground connection of the shield at every node is important, including at high frequencies. Thus, connect a large surface of the shield to ground, for example with a cable clamp or a conductive cable connector. It may be necessary to apply potential-equalizing cables to maintain the same ground potential throughout the network. Particularly in installations with long cables.

To prevent impedance mismatch, always use the same type of cable throughout the entire network. When connecting a motor to the adjustable frequency drive, always use shielded motor cable.

Cable	Shielded twisted pair (STP)
Impedance	120 Ω
Max. cable length (ft [m])	4,000 ft [1,200 m] (including drop lines) 1,650 ft [500 m] station-to-station

Table 2.10 Cable Information

3 Start-up and Functional Test

3.1 Pre-start

3.1.1 Safety Inspection

⚠ WARNING

HIGH VOLTAGE!

If input and output connections have been connected improperly, there is potential for high voltage on these terminals. If power leads for multiple motors are improperly run in the same conduit, there is potential for leakage current to charge capacitors within the adjustable frequency drive, even when disconnected from line power input. For initial start-up, make no assumptions about power components. Follow pre-start procedures. Failure to follow pre-start procedures could result in personal injury or damage to equipment.

1. Input power to the unit must be OFF and locked out. Do not rely on the adjustable frequency drive disconnect switches for input power isolation.
2. Verify that there is no voltage on input terminals L1 (91), L2 (92), and L3 (93), phase-to-phase and phase-to-ground.
3. Verify that there is no voltage on output terminals 96 (U), 97 (V), and 98 (W), phase-to-phase and phase-to-ground.
4. Confirm continuity of the motor by measuring ohm values on U-V (96-97), V-W (97-98), and W-U (98-96).
5. Check for proper grounding of the adjustable frequency drive as well as the motor.
6. Inspect the adjustable frequency drive for loose connections on terminals.
7. Record the following motor nameplate data: power, voltage, frequency, full load current, and nominal speed. These values are needed to program motor nameplate data later.
8. Confirm that the supply voltage matches voltage of adjustable frequency drive and motor.

CAUTION

Before applying power to the unit, inspect the entire installation as detailed in *Table 3.1*. Check mark those items when completed.

Inspect for	Description	<input checked="" type="checkbox"/>
Auxiliary equipment	<ul style="list-style-type: none"> Look for auxiliary equipment, switches, disconnects, or input fuses/circuit breakers that may reside on the input power side of the adjustable frequency drive or output side to the motor. Ensure that they are ready for full speed operation. Check function and installation of any sensors used for feedback to the adjustable frequency drive. Remove power factor correction caps on motor(s), if present. 	
Cable routing	<ul style="list-style-type: none"> Ensure that input power, motor wiring and control wiring are separated or in three separate metallic conduits for high frequency noise isolation. 	
Control wiring	<ul style="list-style-type: none"> Check for broken or damaged wires and loose connections. Check that control wiring is isolated from power and motor wiring for noise immunity. Check the voltage source of the signals, if necessary. The use of shielded cable or twisted pair is recommended. Ensure that the shield is terminated correctly. 	
Cooling clearance	<ul style="list-style-type: none"> Make sure that the top and bottom clearance is adequate to ensure proper airflow for cooling. 	
EMC considerations	<ul style="list-style-type: none"> Check for proper installation regarding electromagnetic compatibility. 	
Environmental considerations	<ul style="list-style-type: none"> See equipment label for the maximum ambient operating temperature limits. Humidity levels must be 5%–95% non-condensing. 	
Fusing and circuit breakers	<ul style="list-style-type: none"> Check for proper fusing or circuit breakers. Check that all fuses are inserted firmly and in operational condition and that all circuit breakers are in the open position. 	
Grounding	<ul style="list-style-type: none"> The unit requires a ground wire from its chassis to the building ground. Check for good ground connections that are tight and free of oxidation. Grounding to conduit or mounting the back panel to a metal surface is not a suitable ground. 	
Input and output power wiring	<ul style="list-style-type: none"> Check for loose connections. Check that motor and line power are in separate conduits or separated shielded cables. 	
Panel interior	<ul style="list-style-type: none"> Make sure that the unit interior is free of dirt, metal chips, moisture, and corrosion. 	
Switches	<ul style="list-style-type: none"> Ensure that all switch and disconnect settings are in the proper positions. 	
Vibration	<ul style="list-style-type: none"> Check that the unit is mounted solidly or that shock mounts are used, as necessary. Check for an unusual amount of vibration. 	

Table 3.1 Start-up Checklist

3.2 Applying Power

⚠ WARNING

HIGH VOLTAGE!

Adjustable frequency drives contain high voltage when connected to AC line power. Installation, start-up and maintenance should be performed by qualified personnel only. Failure to comply could result in death or serious injury.

⚠ WARNING

UNINTENDED START!

When the adjustable frequency drive is connected to AC line power, the motor may start at any time. The adjustable frequency drive, motor, and any driven equipment must be in operational readiness. Failure to comply could result in death, serious injury, equipment, or property damage.

1. Confirm that the input voltage is balanced within 3%. If not, correct input voltage imbalance before proceeding. Repeat this procedure after the voltage correction.
2. Ensure that optional equipment wiring, if present, matches the installation application.
3. Ensure that all operator devices are in the OFF position. Panel doors should be closed or cover mounted.
4. Apply power to the unit. DO NOT start the adjustable frequency drive at this time. For units with a disconnect switch, turn to the ON position to apply power to the adjustable frequency drive.

NOTICE!

If the status line at the bottom of the LCP reads **AUTO REMOTE COASTING** or **Alarm 60 External Interlock** is displayed, this indicates that the unit is ready to operate but is missing an input signal on terminal 27. See *Figure 2.36* for details.

3.3 Basic Operational Programming

3.3.1 Set-up Wizard

The built-in "wizard" menu guides the installer through the set-up of the adjustable frequency drive in a clear and structured manner and has been constructed with reference to the industries refrigeration engineers to ensure that the text and language used makes complete sense to the installer.

At start-up, the FC 103 asks the user to run the VLT Drive Application Guide or to skip it (until it has been run, the FC 103 will ask every time at start-up), thereafter in the event of power failure the application guide is accessed through the Quick Menu screen.

If [Cancel] is pressed, the FC 103 returns to the status screen. An automatic timer will cancel the wizard after five minutes of inactivity (no keys pressed). The wizard must be re-entered through the Quick Menu after it has been run once.

Answering the questions on the screens takes the user through the complete FC 103 set-up. Most standard refrigeration applications can be set up by using this Application Guide. Advanced features must be accessed through the menu structure (Quick Menu or Main Menu) in the adjustable frequency drive.

The FC 103 Wizard covers all standard settings for:

- Compressors
- Single fan and pump
- Condenser fans

These applications then allow the adjustable frequency drive to be further controlled via the adjustable frequency drive's own internal PID controllers or from an external control signal.

After completing the set-up, you can choose to re-run the wizard or start the application.

The Application Guide can be cancelled at any time by pressing [Back]. The Application Guide can be re-entered through the Quick Menu. When re-entering the Application Guide, the user will be asked to keep previous changes to the factory set-up or to restore default values.

On power-up, the FC 103 launches an application guide. In the event of power failure, the application guide is accessed through the Quick Menu screen.

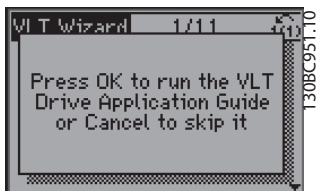

Figure 3.1 Quick Menu Screen

If [Cancel] is pressed, the FC 103 will return to the status screen. An automatic timer will cancel the wizard after five minutes of inactivity (no keys pressed). The wizard must be re-entered through the Quick Menu as described below. If [OK] is pressed, the Application Guide will start with the following screen:



Figure 3.2 Start-up of Application Guide

NOTICE!

Numbering of steps in the wizard (e.g., 1/12) can change depending on workflow choices.

This screen will automatically change to the first input screen of the Application Guide:



Figure 3.3 Language Selection



Figure 3.4 Application Selection

Compressor pack set-up

The following example shows screens for a compressor pack set-up:

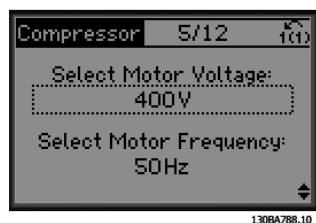

Figure 3.5 Voltage and Frequency Set-up



Figure 3.6 Current and Nominal Speed Set-up



Figure 3.7 Min. and Max. Frequency Set-up



Figure 3.8 Min. Time between Two Starts

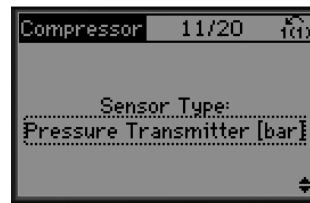

Figure 3.11 Select Sensor Type

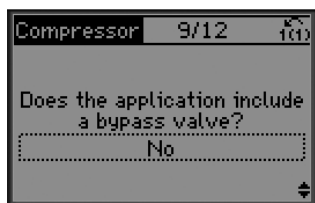

Figure 3.9 Choose with/without Bypass Valve



Figure 3.12 Settings for Sensor

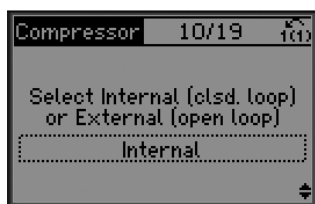

Figure 3.10 Select Open-loop or Closed-loop



Figure 3.13 Info: 4–20 mA Feedback Chosen - Connect Accordingly

NOTICE!

Internal/Closed-loop: The FC 103 will control the application directly using the internal PID control within the adjustable frequency drive and needs an input from an external input such as a temperature or other sensor which is wired directly into the adjustable frequency drive and controls from the sensor signal.

External/Open-loop: The FC 103 takes its control signal from another controller (such as a pack controller) which gives the adjustable frequency drive, e.g., 0–10 V, 4–20 mA or FC 103 Lon. The adjustable frequency drive will change its speed depending upon this reference signal.



Figure 3.14 Info: Set Switch Accordingly

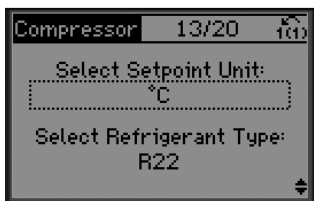

Figure 3.15 Select Unit and Conversion from Pressure

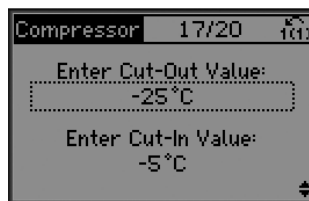

Figure 3.19 Set Cut Out/In Value



Figure 3.16 Select Fixed or Floating Setpoint

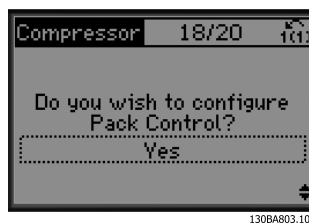

Figure 3.20 Choose Pack Control Set-up

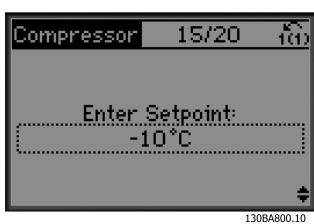

Figure 3.17 Set Setpoint



Figure 3.21 Set Number of Compressors in Pack

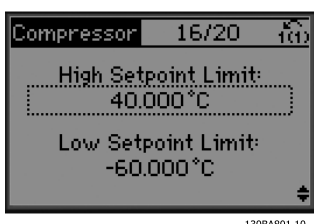

Figure 3.18 Set High/Low Limit for Setpoint



Figure 3.22 Info: Connect Accordingly



Figure 3.23 Info: Set-up Completed

After completing the set-up, you can choose to re-run the wizard or start the application. Select between the following options:

- Re-run wizard.
- Go to Main Menu.
- Go to Status.
- Run AMA - Note this is a reduced AMA if compressor application is selected and full AMA if single fan and pump are selected.
- If condenser fan is selected in the application, NO AMA can be run.
- Run application - This mode starts the adjustable frequency drive in either hand/local mode or via an external control signal if open-loop is selected in an earlier screen.

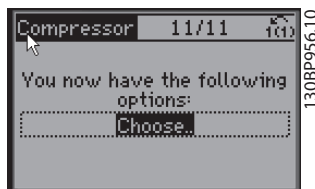

Figure 3.24 Run Application

The Application Guide can be cancelled at any time by pressing [Back]. The Application Guide can be re-entered through the Quick Menu:



Figure 3.25 Quick Menu

When re-entering the Application Guide, select between previous changes to the factory set-up or restore default values.

NOTICE!

If the system requirement is to have the internal pack controller for three compressors plus bypass valve connected, there is the need to specify FC 103 with the extra relay card (MCB 105) mounted inside the adjustable frequency drive.

The bypass valve must be programmed to operate from one of the extra relay outputs on the MCB 105 board. This is needed because the standard relay outputs in the FC 103 are used to control the compressors in the pack.

3.3.2 Required Initial Adjustable Frequency Drive Programming

NOTICE!

If the wizard is run, ignore the following.

Adjustable frequency drives require basic operational programming before running for best performance. Basic operational programming requires entering motor nameplate data for the motor being operated and the minimum and maximum motor speeds. Enter data in accordance with the following procedure. The recommended parameter settings are intended for start-up and checkout purposes. Application settings may vary. See *chapter 4 User Interface* for detailed instructions on entering data through the LCP.

Enter data with power ON, but before operating the adjustable frequency drive.

1. Press [Main Menu] twice on the LCP.
2. Use the navigation keys to scroll to parameter group 0-** Operation/Display and press [OK].

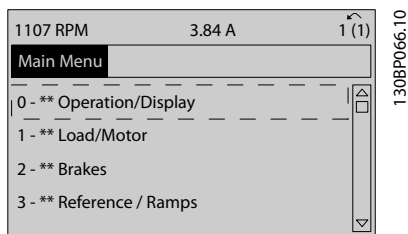

Figure 3.26 Main Menu

3. Use navigation keys to scroll to parameter group 0-0* Basic Settings and press [OK].

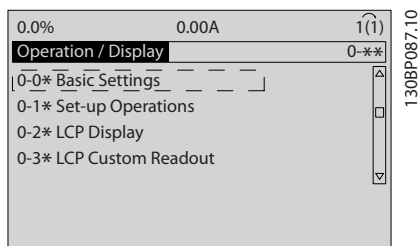

Figure 3.27 Operation/Display

4. Use navigation keys to scroll to 0-03 Regional Settings and press [OK].

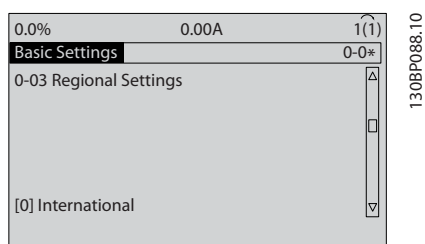

Figure 3.28 Basic Settings

5. Use navigation keys to select [0] International or [1] North America as appropriate and press [OK]. (This changes the default settings for a number of basic parameters. See chapter 5.4 International/ North American Default Parameter Settings for a complete list).
6. Press [Quick Menu] on the LCP.
7. Use the navigation keys to scroll to parameter group Q2 Quick Set-up and press [OK].

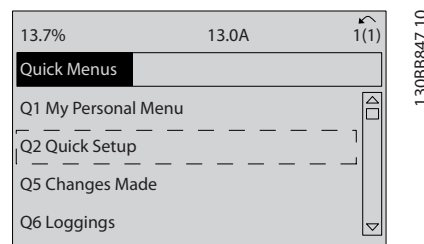

Figure 3.29 Quick Menus

8. Select language and press [OK].
9. A jumper wire should be in place between control terminals 12 and 27. If this is the case, leave 5-12 Terminal 27 Digital Input at factory default. Otherwise select No Operation. For adjustable frequency drives with an optional Danfoss bypass, no jumper wire is required.
10. 3-02 Minimum Reference.
11. 3-03 Maximum Reference.
12. 3-41 Ramp 1 Ramp-up Time.
13. 3-42 Ramp 1 Ramp-down Time.
14. 3-13 Reference Site. Linked to Hand/Auto* Local Remote.

3.4 Asynchronous Motor Set-up

Enter the motor data in parameters 1-20/1-21 to 1-25. The information can be found on the motor nameplate.

1. *1-20 Motor Power [kW] or 1-21 Motor Power [HP]*
- 1-22 Motor Voltage*
- 1-23 Motor Frequency*
- 1-24 Motor Current*
- 1-25 Motor Nominal Speed*

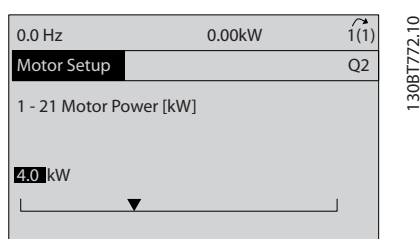

Figure 3.30 Motor Set-up

3.5 Automatic Motor Adaptation

Automatic motor adaptation (AMA) is a test procedure that measures the electrical characteristics of the motor to optimize compatibility between the adjustable frequency drive and the motor.

- The adjustable frequency drive builds a mathematical model of the motor for regulating output motor current. The procedure also tests the input phase balance of electrical power. It compares the motor characteristics with the data entered in parameters 1-20 to 1-25.
- The motor shaft does not turn and no harm is done to the motor while running the AMA.
- Some motors may be unable to run the complete version of the test. In that case, select [2] *Enable reduced AMA*.
- If an output filter is connected to the motor, select *Enable reduced AMA*.
- If warnings or alarms occur, see *chapter 8 Warnings and Alarms*.
- Run this procedure on a cold motor for best results.

NOTICE!

The AMA algorithm does not work when using PM motors.

To run AMA

1. Press [Main Menu] to access parameters.
2. Scroll to parameter group 1-2* *Load and Motor*.
3. Press [OK].
4. Scroll to parameter group 1-2* *Motor Data*.
5. Press [OK].
6. Scroll to 1-29 *Automatic Motor Adaptation (AMA)*.
7. Press [OK].
8. Select [1] *Enable complete AMA*.
9. Press [OK].
10. Follow the on-screen instructions.
11. The test will run automatically and indicate when it is complete.

3.6 PM Motor Set-up in VVC^{plus}

CAUTION

Use only a PM motor with fans and pumps.

Initial Programming Steps

1. Activate PM motor operation 1-10 *Motor Construction*, select [1] *PM, non-salient SPM*
2. Make sure to set 0-02 *Motor Speed Unit* to [0] *RPM*

Programming motor data

After selecting PM motor in 1-10 *Motor Construction*, the PM motor-related parameters in parameter groups 1-2* *Motor Data*, 1-3* *Adv. Motor Data* and 1-4* are active. The information can be found on the motor nameplate and in the motor data sheet.

The following parameters must be programmed in the listed order:

1. 1-24 *Motor Current*.
2. 1-26 *Motor Cont. Rated Torque*.
3. 1-25 *Motor Nominal Speed*.
4. 1-39 *Motor Poles*.
5. 1-30 *Stator Resistance (Rs)*.
Enter line to common stator winding resistance (Rs). If only line-line data are available, divide the line-line value by 2 to achieve the line to common (starpoint) value.

It is also possible to measure the value with an ohmmeter, which will also take the resistance of the cable into account. Divide the measured value by 2 and enter the result.

6. *1-37 d-axis Inductance (Ld).*

Enter line to common direct axis inductance of the PM motor.

If only line-line data are available, divide the line-line value by 2 to achieve the line-common (starpoint) value.

It is also possible to measure the value with an inductance meter, which will also take the inductance of the cable into account. Divide the measured value by 2 and enter the result.

7. *1-40 Back EMF at 1000 RPM.*

Enter line-to-line back EMF of PM Motor at 1,000 RPM mechanical speed (RMS value). Back EMF is the voltage generated by a PM motor when no drive is connected and the shaft is turned externally. Back EMF is normally specified for nominal motor speed or for 1000 RPM measured between two lines. If the value is not available for a motor speed of 1000 RPM, calculate the correct value as follows: If back EMF is, e.g., 320 V at 1800 RPM, it can be calculated at 1000 RPM as follows: Back EMF = (Voltage / RPM) * 1000 = (320/1800) * 1000 = 178. This is the value that must be programmed for *1-40 Back EMF at 1000 RPM*.

Test Motor Operation

1. Start the motor at low speed (100 to 200 RPM). If the motor does not turn, check installation, general programming and motor data.
2. Check if start function in *1-70 PM Start Mode* fits the application requirements.

Rotor detection

This function is the recommended choice for applications where the motor starts from standstill, e.g., pumps or conveyors. On some motors, an acoustic sound is heard when the impulse is sent out. This does not harm the motor.

Parking

This function is the recommended choice for applications where the motor is rotating at slow speed, e.g., windmilling in fan applications. *2-06 Parking Current* and *2-07 Parking Time* can be adjusted. Increase the factory setting of these parameters for applications with high inertia.

Start the motor at nominal speed. In case the application does not run well, check the VVC^{plus} PM settings.

Recommendations for different applications can be seen in *Table 3.2*.

Application	Settings
Low inertia applications $I_{Load}/I_{Motor} < 5$	<i>1-17 Voltage filter time const.</i> to be increased by factor 5 to 10 <i>1-14 Damping Gain</i> should be reduced <i>1-66 Min. Current at Low Speed</i> should be reduced (<100%)
Low inertia applications $50 > I_{Load}/I_{Motor} > 5$	Keep calculated values
High inertia applications $I_{Load}/I_{Motor} > 50$	<i>1-14 Damping Gain</i> , <i>1-15 Low Speed Filter Time Const.</i> and <i>1-16 High Speed Filter Time Const.</i> should be increased
High load at low speed <30% (rated speed)	<i>1-17 Voltage filter time const.</i> should be increased <i>1-66 Min. Current at Low Speed</i> should be increased (>100% for longer time can overheat the motor)

Table 3.2 Recommendations for Different Applications

If the motor starts oscillating at a certain speed, increase *1-14 Damping Gain*. Increase the value in small steps. Depending on the motor, a good value for this parameter can be 10% or 100% higher than the default value.

Starting torque can be adjusted in *1-66 Min. Current at Low Speed*. 100% provides nominal torque as starting torque.

3.7 Check Motor Rotation

Before running the adjustable frequency drive, check the motor rotation. The motor will run briefly at 5 Hz or the minimum frequency set in *4-12 Motor Speed Low Limit [Hz]*.

1. Press [Quick Menu].
2. Scroll to *Q2 Quick Set-up*.
3. Press [OK].
4. Scroll to *1-28 Motor Rotation Check*.
5. Press [OK].
6. Scroll to *[1] Enable*.

The following text will appear: *Note! Motor may run in wrong direction.*

7. Press [OK].
8. Follow the on-screen instructions.

To change the direction of rotation, remove power to the adjustable frequency drive and wait for power to discharge. Reverse the connection of any two of the three motor cables on the motor or adjustable frequency drive side of the connection.

3.8 Local Control Test

CAUTION

MOTOR START!

Ensure that the motor, system and any attached equipment are ready for start. It is the responsibility of the user to ensure safe operation under any condition. Failure to ensure that the motor, system, and any attached equipment are ready for start could result in personal injury or equipment damage.

NOTICE!

The [Hand On] key provides a local start command to the adjustable frequency drive. The [Off] key provides the stop function.

When operating in local mode, [▲] and [▼] increase and decrease the speed output of the adjustable frequency drive. [◀] and [▶] move the display cursor in the numeric display.

1. Press [Hand On].
2. Accelerate the adjustable frequency drive by pressing [▲] to full speed. Moving the cursor left of the decimal point provides quicker input changes.
3. Note any acceleration problems.
4. Press [Off].
5. Note any deceleration problems.

If acceleration problems were encountered

- If warnings or alarms occur, see *chapter 8 Warnings and Alarms*.
- Check that motor data is entered correctly.
- Increase the ramp-up time in *3-41 Ramp 1 Ramp-up Time*.
- Increase current limit in *4-18 Current Limit*.
- Increase torque limit in *4-16 Torque Limit Motor Mode*.

If deceleration problems were encountered

- If warnings or alarms occur, see *chapter 8 Warnings and Alarms*.
- Check that motor data is entered correctly.
- Increase the ramp-down time in *3-42 Ramp 1 Ramp-down Time*.
- Enable overvoltage control in *2-17 Over-voltage Control*.

See *chapter 4.1.1 LCP Layout* for resetting the adjustable frequency drive after a trip.

NOTICE!

Chapter 3.1 Pre-start to chapter 3.8 Local Control Test conclude the procedures for applying power to the adjustable frequency drive, basic programming, set-up and functional testing.

3.9 System Start-up

The procedure in this section requires user-wiring and application programming to be completed. *chapter 6 Application Set-up Examples* is intended to help with this task. Other aids to application set-up are listed in *chapter 6 Application Set-up Examples*. The following procedure is recommended after application set-up by the user is completed.

⚠ CAUTION

MOTOR START!

Ensure that the motor, system and any attached equipment is ready for start. It is the responsibility of the user to ensure safe operation under any condition. Failure to do so could result in personal injury or equipment damage.

1. Press [Auto On].
2. Ensure that external control functions are properly wired to the adjustable frequency drive and all programming completed.
3. Apply an external run command.
4. Adjust the speed reference throughout the speed range.
5. Remove the external run command.
6. Note any problems.

If warnings or alarms occur, see *chapter 8 Warnings and Alarms*.

4 User Interface

4.1 Local Control Panel

The local control panel (LCP) is the combined display and keypad on the front of the unit. The LCP is the user interface to the adjustable frequency drive.

The LCP has several user functions.

- Start, stop, and control speed when in local control
- Display operational data, status, warnings and cautions
- Programming adjustable frequency drive functions
- Manually reset the adjustable frequency drive after a fault when auto-reset is inactive

An optional numeric LCP (NLCP) is also available. The NLCP operates in a manner similar to the LCP. See the Programming Guide for details on use of the NLCP.

NOTICE!

The display contrast can be adjusted by pressing [Status] and [▲]/[▼] keys.

4.1.1 LCP Layout

The LCP is divided into four functional groups (see Figure 4.1).

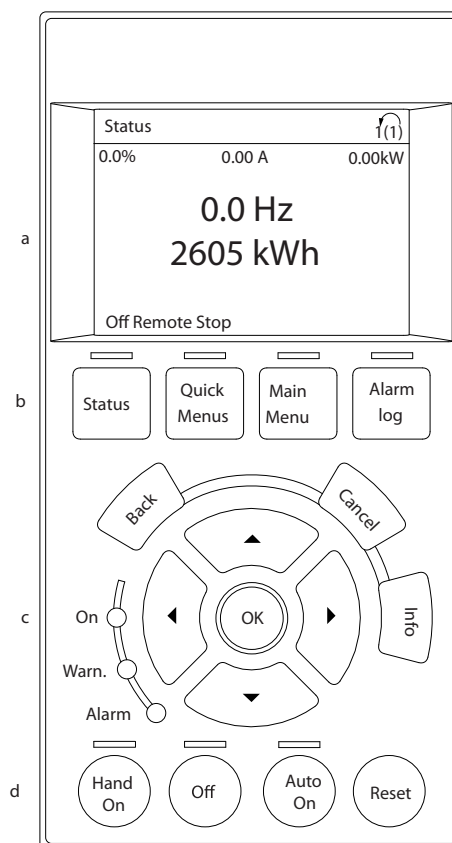

1308D390.10

Figure 4.1 LCP

- Display area.
- Display menu keys for changing the display to show status options, programming, or error message history.
- Navigation keys for programming functions, moving the display cursor, and speed control in local operation. Also included are the status indicator lights.
- Operational mode keys and reset.

4.1.2 Setting LCP Display Values

The display area is activated when the adjustable frequency drive receives power from AC line voltage, a DC bus terminal, or an external 24 V DC supply.

The information displayed on the LCP can be customized for user application.

- Each display readout has a parameter associated with it
- Options are selected in the quick menu Q3-13 *Display Settings*
- Display 2 has an alternate larger display option
- The adjustable frequency drive status at the bottom line of the display is generated automatically and is not selectable

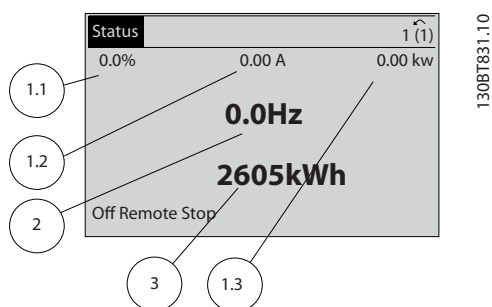

Figure 4.2 Display Readouts

Display	Parameter number	Default setting
1.1	0-20	Reference %
1.2	0-21	Motor current
1.3	0-22	Power [kW]
2	0-23	Frequency
3	0-24	kWh counter

Table 4.1 Legend to Figure 4.2

4.1.3 Display Menu Keys

Menu keys are used for menu access for parameter set-up, toggling through status display modes during normal operation, and viewing fault log data.



Figure 4.3 Menu Keys

Key	Function
Status	Shows operational information. <ul style="list-style-type: none"> • In Auto mode, press to toggle between status readout displays. • Press repeatedly to scroll through each status display. • Press [Status] plus [▲] or [▼] to adjust the display brightness. • The symbol in the upper right corner of the display shows the direction of motor rotation and which set-up is active. This is not programmable.
Quick Menu	Allows access to programming parameters for initial set-up instructions and many detailed application instructions. <ul style="list-style-type: none"> • Press to access Q2 <i>Quick Set-up</i> for sequenced instructions to program the basic adjustable frequency drive set-up • Follow the sequence of parameters as presented for the function set-up.
Main Menu	Allows access to all programming parameters. <ul style="list-style-type: none"> • Press twice to access top-level index. • Press once to return to the last location accessed. • Press to enter a parameter number for direct access to that parameter.
Alarm Log	Displays a list of current warnings, the last ten alarms, and the maintenance log. <ul style="list-style-type: none"> • For details about the adjustable frequency drive before it entered the alarm mode, select the alarm number using the navigation keys and press [OK].

Table 4.2 Function Description Menu Keys

130BP045.10

4.1.4 Navigation Keys

Navigation keys are used for programming functions and moving the display cursor. The navigation keys also provide speed control in local (hand) operation. Three adjustable frequency drive status indicators are also located in this area.

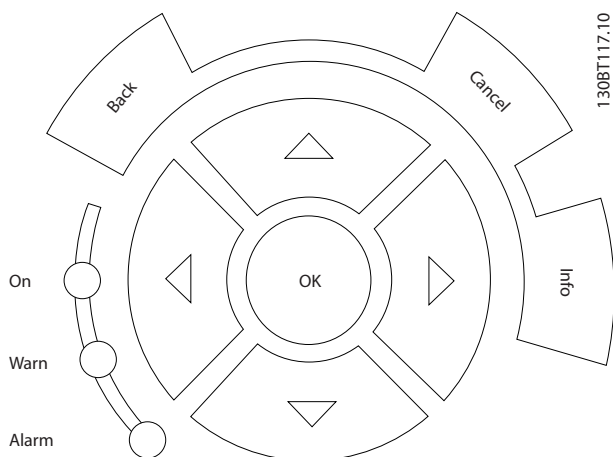

Figure 4.4 Navigation Keys

Key	Function
Back	Reverts to the previous step or list in the menu structure.
Cancel	Cancel the last change or command as long as the display mode has not changed.
Info	Press for a definition of the function being displayed.
Navigation Keys	Use the four navigation keys to move between items in the menu.
OK	Use to access parameter groups or to enable a choice.

Table 4.3 Navigation Keys Functions

Light	Indicator	Function
Green	ON	The ON light activates when the adjustable frequency drive receives power from AC line voltage, a DC bus terminal, or an external 24 V supply.
Yellow	WARN	When warning conditions are met, the yellow WARN light comes on and text appears in the display area identifying the problem.
Red	ALARM	A fault condition causes the red alarm light to flash and an alarm text is displayed.

Table 4.4 Indicator Lights Functions

4.1.5 Operation Keys

Operation keys are found at the bottom of the LCP.

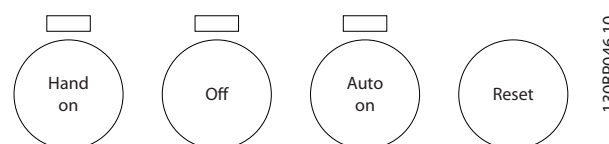

Figure 4.5 Operation Keys

Key	Function
Hand On	Starts the adjustable frequency drive in local control. <ul style="list-style-type: none"> Use the navigation keys to control adjustable frequency drive speed. An external stop signal by control input or serial communication overrides the local hand on
Off	Stops the motor but does not remove power to the adjustable frequency drive.
Auto On	Puts the system in remote operational mode. <ul style="list-style-type: none"> Responds to an external start command by control terminals or serial communication. Speed reference is from an external source.
Reset	Resets the adjustable frequency drive manually after a fault has been cleared.

Table 4.5 Operation Keys Functions

4.2 Backup and Copying Parameter Settings

Programming data is stored internally in the adjustable frequency drive.

- The data can be uploaded into the LCP memory as a storage backup.
- Once stored in the LCP, the data can be downloaded back into the adjustable frequency drive.
- Data can also be downloaded into other adjustable frequency drives by connecting the LCP into those units and downloading the stored settings. (This is a quick way to program multiple units with the same settings).
- Initialization of the adjustable frequency drive to restore factory default settings does not change data stored in the LCP memory.

⚠ WARNING

UNINTENDED START!

When the adjustable frequency drive is connected to AC line power, the motor may start at any time. The adjustable frequency drive, motor, and any driven equipment must be in operational readiness. Failure to be in operational readiness when the adjustable frequency drive is connected to AC line power could result in death, serious injury, or equipment or property damage.

4.2.1 Uploading Data to the LCP

1. Press [Off] to stop the motor before uploading or downloading data.
2. Go to *0-50 LCP Copy*.
3. Press [OK].
4. Select *All to LCP*.
5. Press [OK]. A progress bar shows the uploading process.
6. Press [Hand On] or [Auto On] to return to normal operation.

4.2.2 Downloading Data from the LCP

1. Press [Off] to stop the motor before uploading or downloading data.
2. Go to *0-50 LCP Copy*.
3. Press [OK].
4. Select *All from LCP*.
5. Press [OK]. A progress bar shows the downloading process.
6. Press [Hand On] or [Auto On] to return to normal operation.

4.3 Restoring Default Settings

CAUTION

Initialization restores the unit to factory default settings. Any programming, motor data, localization, and monitoring records will be lost. Uploading data to the LCP provides a backup before initialization.

Restoring the adjustable frequency drive parameter settings back to default values is done by initialization of the adjustable frequency drive. Initialization can be through *14-22 Operation Mode* or manually.

- Initialization using *14-22 Operation Mode* does not change adjustable frequency drive data such as operating hours, serial communication selections, personal menu settings, fault log, alarm log, and other monitoring functions.
- Using *14-22 Operation Mode* is generally recommended.
- Manual initialization erases all motor, programming, localization, and monitoring data and restores factory default settings.

4.3.1 Recommended Initialization

1. Press [Main Menu] twice to access parameters.
2. Scroll to *14-22 Operation Mode*.
3. Press [OK].
4. Scroll to *Initialization*.
5. Press [OK].
6. Remove power to the unit and wait for the display to turn off.
7. Apply power to the unit.

Default parameter settings are restored during start-up. This may take slightly longer than normal.

8. Alarm 80 is displayed.
9. Press [Reset] to return to operation mode.

4.3.2 Manual Initialization

1. Remove power to the unit and wait for the display to turn off.
2. Press and hold [Status], [Main Menu], and [OK] at the same time and apply power to the unit.

Factory default parameter settings are restored during start-up. This may take slightly longer than normal.

Manual initialization does not reset the following adjustable frequency drive information

- *15-00 Operating hours*
- *15-03 Power-ups*
- *15-04 Over Temps*
- *15-05 Over Volts*

4.4 How to Operate

4.4.1 Five Ways of Operating

The adjustable frequency drive can be operated in five ways:

1. Graphical Local Control Panel (GLCP)
2. RS-485 serial communication or USB, both for PC connection
3. Via AK Lon⇒Gateway⇒ AKM programming software
4. Via AK Lon ⇒ system manager ⇒service tool programming software
5. Via MCT 10 Set-up Software, see *chapter 4.5 Remote Programming with MCT 10 Set-up Software*

If the adjustable frequency drive is fitted with serial communication option, refer to the relevant documentation.

NOTICE!

The AKM programming software can be downloaded from www.danfoss.com

4.5 Remote Programming with MCT 10 Set-up Software

Danfoss has a software program available for developing, storing, and transferring adjustable frequency drive programming. The MCT 10 Set-up Software allows the user to connect a PC to the adjustable frequency drive and perform live programming rather than using the LCP. Additionally, all adjustable frequency drive programming can be done off-line and simply downloaded to the adjustable frequency drive. Or the entire adjustable frequency drive profile can be loaded onto the PC for backup storage or analysis.

The USB connector or RS-485 terminal is available for connecting to the adjustable frequency drive.

5 Programming

5.1 Introduction

The adjustable frequency drive is programmed for its application functions using parameters. Parameters are accessed by pressing either [Quick Menu] or [Main Menu] on the LCP. (See *chapter 4 User Interface* for details on using the LCP function keys.) Parameters may also be accessed through a PC using the MCT 10 Set-up Software, go to www.VLT-software.com.

The quick menu is intended for initial start-up (Q2-** *Quick Set-up*) and detailed instructions for common adjustable frequency drive applications (Q3-** *Function Set-up*). Step-by-step instructions are provided. These instructions enable the user to walk through the parameters used for programming applications in their proper sequence. Data entered in a parameter can change the options available in the parameters following that entry. The quick menu presents easy guidelines for getting most systems up and running.

The main menu accesses all parameters and allows for advanced adjustable frequency drive applications.

5.2 Programming Example

Here is an example for programming the adjustable frequency drive for a common application in open-loop using the quick menu.

- This procedure programs the adjustable frequency drive to receive a 0–10 V DC analog control signal on input terminal 53
- The adjustable frequency drive will respond by providing 6–60 Hz output to the motor proportional to the input signal (0–10 V DC = 6–60 Hz)

Select the following parameters using the navigation keys to scroll to the titles and press [OK] after each action.

1. 3-15 Reference Resource 1

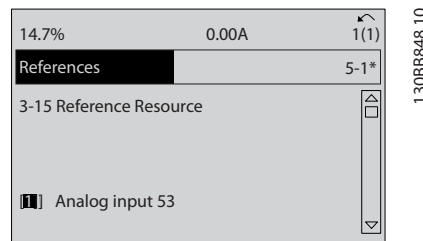

Figure 5.1 Programming Example Step 1

2. 3-02 Minimum Reference. Set minimum internal adjustable frequency drive reference to 0 Hz. (This sets the minimum adjustable frequency drive speed at 0 Hz.)

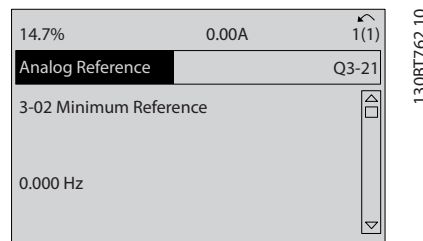

Figure 5.2 Programming Example Step 2

3. 3-03 Maximum Reference. Set maximum internal adjustable frequency drive reference to 60 Hz. (This sets the maximum adjustable frequency drive speed at 60 Hz. Note that 50/60 Hz is a regional variation.)

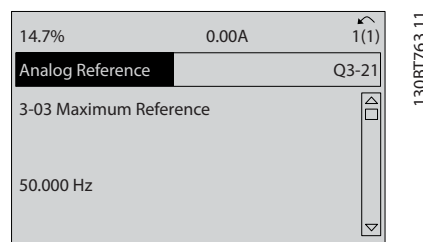

Figure 5.3 Programming Example Step 3

4. **6-10 Terminal 53 Low Voltage.** Set minimum external voltage reference on Terminal 53 at 0 V. (This sets the minimum input signal at 0 V.)

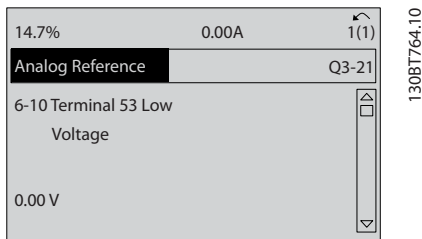

Figure 5.4 Programming Example Step 4

5. **6-11 Terminal 53 High Voltage.** Set maximum external voltage reference on Terminal 53 at 10 V. (This sets the maximum input signal at 10 V.)

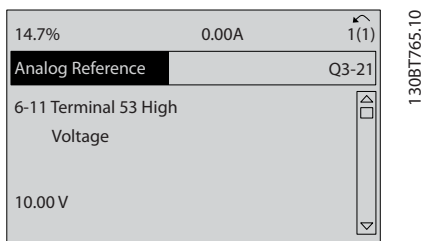

Figure 5.5 Programming Example Step 5

6. **6-14 Terminal 53 Low Ref./Feedb. Value.** Set minimum speed reference on Terminal 53 at 6 Hz. (This tells the adjustable frequency drive that the minimum voltage received on Terminal 53 (0 V) equals 6 Hz output.)

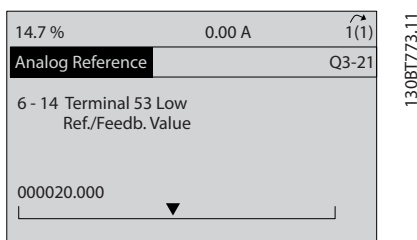

Figure 5.6 Programming Example Step 6

7. **6-15 Terminal 53 High Ref./Feedb. Value.** Set maximum speed reference on Terminal 53 at 60 Hz. (This tells the adjustable frequency drive that the maximum voltage received on Terminal 53 (10 V) equals 60 Hz output.)

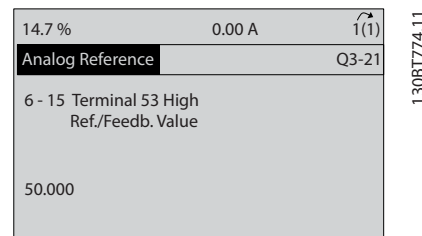

Figure 5.7 Programming Example Step 7

With an external device providing a 0–10 V control signal connected to adjustable frequency drive terminal 53, the system is now ready for operation. Note that the scroll bar on the right in the last figure of the display is at the bottom, indicating the procedure is complete.

Figure 5.8 shows the wiring connections used to enable this set-up.

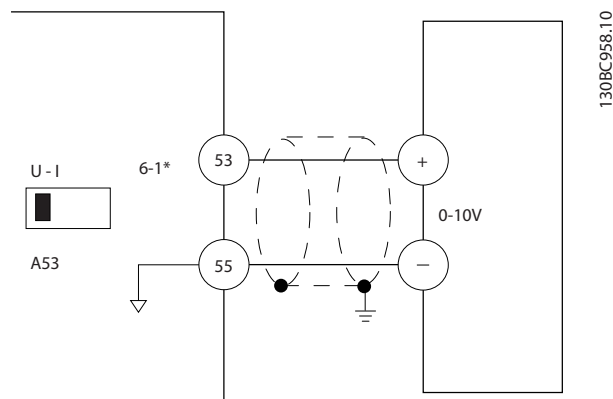

Figure 5.8 Wiring Example for External Device Providing 0–10 V Control Signal (Adjustable Frequency Drive Left, External Device Right)

5.3 Control Terminal Programming Examples

Control terminals can be programmed.

- Each terminal has specified functions it is capable of performing.
- Parameters associated with the terminal enable the function.

See *Table 2.5* for control terminal parameter number and default setting. (Default setting can change based on the selection in *0-03 Regional Settings*).

The following example shows accessing Terminal 18 to see the default setting.

1. Press [Main Menu] twice, scroll to parameter group 5-** *Digital In/Out* and press [OK].

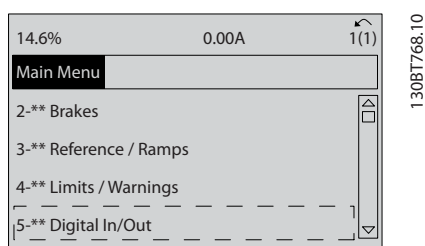

Figure 5.9 6-15 Terminal 53 High Ref./Feedb. Value

2. Scroll to parameter group 5-1* *Digital Inputs* and press [OK].

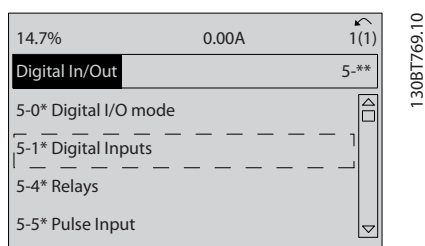

Figure 5.10 Digital In/Out

3. Scroll to *5-10 Terminal 18 Digital Input*. Press [OK] to access function choices. The default setting *Start* is shown.

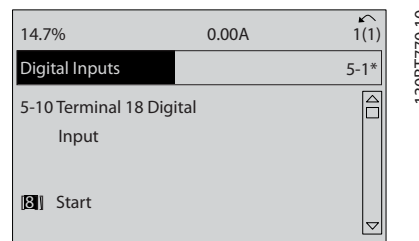

Figure 5.11 Digital Inputs

5.4 International/North American Default Parameter Settings

Setting *0-03 Regional Settings* to *[0] International* or *[1] North America* changes the default settings for some parameters. *Table 5.1* lists those parameters that are effected.

Parameter	International default parameter value	North American default parameter value
0-03 Regional Settings	International	North America
1-20 Motor Power [kW]	See Note 1	See Note 1
1-21 Motor Power [HP]	See Note 2	See Note 2
1-22 Motor Voltage	230 V/400 V/575 V	208 V/460 V/575 V
1-23 Motor Frequency	50 Hz	60 Hz
3-03 Maximum Reference	50 Hz	60 Hz
3-04 Reference Function	Sum	External/Preset
4-13 Motor Speed High Limit [RPM] See Note 3 and 5	1500 PM	1800 RPM
4-14 Motor Speed High Limit [Hz] See Note 4	50 Hz	60 Hz
4-19 Max Output Frequency	100 Hz	120 Hz
4-53 Warning Speed High	1500 RPM	1800 RPM
5-12 Terminal 27 Digital Input	Coast inverse	External interlock
5-40 Function Relay	Alarm	No alarm

Parameter	International default parameter value	North American default parameter value
6-15 Terminal 53 High Ref./Feedb. Value	50	60
6-50 Terminal 42 Output	Speed 0-HighLim	Speed 4-20 mA
14-20 Reset Mode	Manual reset	Infinite auto reset

Table 5.1 International/North American Default Parameter Settings

Note 1: 1-20 Motor Power [kW] is only visible when 0-03 Regional Settings is set to [0] International.

Note 2: 1-21 Motor Power [HP], is only visible when 0-03 Regional Settings is set to [1] North America.

Note 3: This parameter is only visible when 0-02 Motor Speed Unit is set to [0] RPM.

Note 4: This parameter is only visible when 0-02 Motor Speed Unit is set to [1] Hz.

Note 5: The default value depends on the number of motor poles. For a 4-poled motor, the international default value is 1500 RPM, and for a 2-poled motor, 3000 RPM. The corresponding values for North America is 1800 and 3600 RPM, respectively.

Changes made to default settings are stored and available for viewing in the Quick Menu along with any programming entered into parameters.

1. Press [Quick Menu].
2. Scroll to Q5 Changes Made and press [OK].
3. Select Q5-2 *Since Factory Setting* to view all programming changes or Q5-1 *Last 10 Changes* for the most recent.

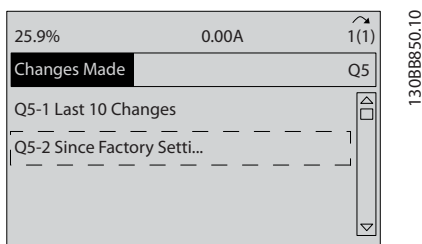

Figure 5.12 Changes Made

5.4.1 Parameter Data Check

1. Press [Quick Menu].
2. Scroll to Q5 Changes Made and press [OK].

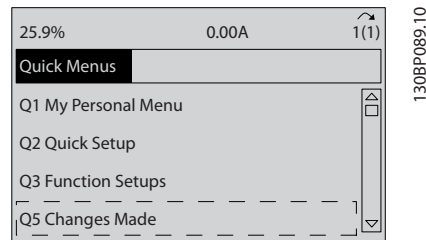

Figure 5.13 Q5 Changes Made

3. Select Q5-2 *Since Factory Setting* to view all programming changes or Q5-1 *Last 10 Changes* for the most recent.

5.5 Parameter Menu Structure

Establishing the correct programming for applications often requires setting functions in several related parameters. These parameter settings provide the adjustable frequency drive with system details it needs to operate properly. System details may include such things as input and output signal types, programming terminals, minimum and maximum signal ranges, custom displays, automatic restart, and other features.

- See the LCP display to view detailed parameter programming and setting options.
- Press [Info] in any menu location to view additional details for that function.
- Press and hold [Main Menu] to enter a parameter number for direct access to that parameter.
- Details for common application set-ups are provided in *chapter 6 Application Set-up Examples*.

5.5.1 Quick Menu Structure

Q3-1 General Settings	0-24 Display Line 3 Large	1-00 Configuration Mode	Q3-31 Single Zone Ext. Setpoint	20-70 Closed-loop Type
Q3-10 Adv. Motor Settings	0-37 Display Text 1	20-12 Reference/Feedback Unit	1-00 Configuration Mode	20-71 PID Performance
1-90 Motor Thermal Protection	0-38 Display Text 2	20-13 Minimum Reference/Feedb.	20-12 Reference/Feedback Unit	20-72 PID Output Change
1-93 Thermistor Source	0-39 Display Text 3	20-14 Maximum Reference/Feedb.	20-13 Minimum Reference/Feedb.	20-73 Minimum Feedback Level
1-29 Automatic Motor Adaptation (AMA)	Q3-2 Open-loop Settings	6-22 Terminal 54 Low Current	20-14 Maximum Reference/Feedb.	20-74 Maximum Feedback Level
14-01 Switching Frequency	Q3-20 Digital Reference	6-24 Terminal 54 Low Ref./Feedb. Value	6-10 Terminal 53 Low Voltage	20-79 PID Autotuning
4-53 Warning Speed High	3-02 Minimum Reference	6-25 Terminal 54 High Ref./Feedb. Value	6-11 Terminal 53 High Voltage	Q3-32 Multi Zone / Adv
Q3-11 Analog Output	3-03 Maximum Reference	6-26 Terminal 54 Filter Time Constant	6-12 Terminal 53 Low Current	1-00 Configuration Mode
6-50 Terminal 42 Output	3-10 Preset Reference	6-27 Terminal 54 Live Zero	6-13 Terminal 53 High Current	3-15 Reference 1 Source
6-51 Terminal 42 Output Min Scale	5-13 Terminal 29 Digital Input	6-00 Live Zero Timeout Time	6-14 Terminal 53 Low Ref./Feedb. Value	3-16 Reference 2 Source
6-52 Terminal 42 Output Max Scale	5-14 Terminal 32 Digital Input	6-01 Live Zero Timeout Function	6-15 Terminal 53 High Ref./Feedb. Value	20-00 Feedback 1 Source
Q3-12 Clock Settings	5-15 Terminal 33 Digital Input	20-21 Setpoint 1	6-22 Terminal 54 Low Current	20-01 Feedback 1 Conversion
0-70 Date and Time	Q3-21 Analog Reference	20-81 PID Normal/ Inverse Control	6-24 Terminal 54 Low Ref./Feedb. Value	20-02 Feedback 1 Source Unit
0-71 Date Format	3-02 Minimum Reference	20-82 PID Start Speed [RPM]	6-25 Terminal 54 High Ref./Feedb. Value	20-03 Feedback 2 Source
0-72 Time Format	3-03 Maximum Reference	20-83 PID Start Speed [Hz]	6-26 Terminal 54 Filter Time Constant	20-04 Feedback 2 Conversion
0-74 DST/Summertime	6-10 Terminal 53 Low Voltage	20-93 PID Proportional Gain	6-27 Terminal 54 Live Zero	20-05 Feedback 2 Source Unit
0-76 DST/Summertime Start	6-11 Terminal 53 High Voltage	20-94 PID Integral Time	6-00 Live Zero Timeout Time	20-06 Feedback 3 Source
0-77 DST/Summertime End	6-12 Terminal 53 Low Current	20-70 Closed-loop Type	6-01 Live Zero Timeout Function	20-07 Feedback 3 Conversion
Q3-13 Display Settings	6-13 Terminal 53 High Current	20-71 PID Performance	20-81 PID Normal/ Inverse Control	20-08 Feedback 3 Source Unit
0-20 Display Line 1.1 Small	6-14 Terminal 53 Low Ref./Feedb. Value	20-72 PID Output Change	20-82 PID Start Speed [RPM]	20-12 Reference/Feedback Unit
0-21 Display Line 1.2 Small	6-15 Terminal 53 High Ref./Feedb. Value	20-73 Minimum Feedback Level	20-83 PID Start Speed [Hz]	20-13 Minimum Reference/Feedb.

Table 5.2 Quick Menu Structure

0-22 Display Line 1.3 Small	Q3-3 Closed-loop Settings	20-74 Maximum Feedback Level	20-93 PID Proportional Gain	20-14 Maximum Reference/Feedb.
0-23 Display Line 2 Large	Q3-30 Single Zone Int. Setpoint	20-79 PID Autotuning	20-94 PID Integral Time	6-10 Terminal 53 Low Voltage
6-11 Terminal 53 High Voltage	20-21 Setpoint 1	22-22 Low Speed Detection	22-21 Low Power Detection	22-87 Pressure at No-Flow Speed
6-12 Terminal 53 Low Current	20-22 Setpoint 2	22-23 No-Flow Function	22-22 Low Speed Detection	22-88 Pressure at Rated Speed
6-13 Terminal 53 High Current	20-81 PID Normal/ Inverse Control	22-24 No-Flow Delay	22-23 No-Flow Function	22-89 Flow at Design Point
6-14 Terminal 53 Low Ref./Feedb. Value	20-82 PID Start Speed [RPM]	22-40 Minimum Run Time	22-24 No-Flow Delay	22-90 Flow at Rated Speed
6-15 Terminal 53 High Ref./Feedb. Value	20-83 PID Start Speed [Hz]	22-41 Minimum Sleep Time	22-40 Minimum Run Time	1-03 Torque Characteristics
6-16 Terminal 53 Filter Time Constant	20-93 PID Proportional Gain	22-42 Wake-up Speed [RPM]	22-41 Minimum Sleep Time	1-73 Flying Start
6-17 Terminal 53 Live Zero	20-94 PID Integral Time	22-43 Wake-up Speed [Hz]	22-42 Wake-up Speed [RPM]	Q3-42 Compressor Functions
6-20 Terminal 54 Low Voltage	20-70 Closed-loop Type	22-44 Wake-up Ref./FB Difference	22-43 Wake-up Speed [Hz]	1-03 Torque Characteristics
6-21 Terminal 54 High Voltage	20-71 PID Performance	22-45 Setpoint Boost	22-44 Wake-up Ref./FB Difference	1-71 Start Delay
6-22 Terminal 54 Low Current	20-72 PID Output Change	22-46 Maximum Boost Time	22-45 Setpoint Boost	22-75 Short Cycle Protection
6-23 Terminal 54 High Current	20-73 Minimum Feedback Level	2-10 Brake Function	22-46 Maximum Boost Time	22-76 Interval between Starts
6-24 Terminal 54 Low Ref./Feedb. Value	20-74 Maximum Feedback Level	2-16 AC Brake Max. Current	22-26 Dry Pump Function	22-77 Minimum Run Time
6-25 Terminal 54 High Ref./Feedb. Value	20-79 PID Autotuning	2-17 Over-voltage Control	22-27 Dry Pump Delay	5-01 Terminal 27 Mode
6-26 Terminal 54 Filter Time Constant	Q3-4 Application Settings	1-73 Flying Start	22-80 Flow Compensation	5-02 Terminal 29 Mode
6-27 Terminal 54 Live Zero	Q3-40 Fan Functions	1-71 Start Delay	22-81 Square-linear Curve Approximation	5-12 Terminal 27 Digital Input
6-00 Live Zero Timeout Time	22-60 Broken Belt Function	1-80 Function at Stop	22-82 Work Point Calculation	5-13 Terminal 29 Digital Input
6-01 Live Zero Timeout Function	22-61 Broken Belt Torque	2-00 DC Hold/Preheat Current	22-83 Speed at No-Flow [RPM]	5-40 Function Relay
4-56 Warning Feedback Low	22-62 Broken Belt Delay	4-10 Motor Speed Direction	22-84 Speed at No-Flow [Hz]	1-73 Flying Start
4-57 Warning Feedback High	4-64 Semi-Auto Bypass Set-up	Q3-41 Pump Functions	22-85 Speed at Design Point [RPM]	1-86 Trip Speed Low [RPM]
20-20 Feedback Function	1-03 Torque Characteristics	22-20 Low Power Auto. Set-up	22-86 Speed at Design Point [Hz]	1-87 Trip Speed Low [Hz]

Table 5.3 Quick Menu Structure

Code	Parameter Name	Description	Units	Factory Default	Adjustment Range	Notes
1-0*	General Settings					
1-00	Configuration Mode	Min Speed for Function at Stop [RPM]	RPM	4-13	Motor Speed High Limit [RPM]	Terminal 27 Pulse Output Variable
1-03	Torque Characteristics	Min Speed for Function at Stop [Hz]	Hz	4-14	Motor Speed High Limit [Hz]	Pulse Output Max Freq #27
1-1*	Motor Selection	Compressor Min. Speed for Trip [RPM]	RPM	4-16	Torque Limit Motor Mode	Terminal 29 Pulse Output Variable
1-10	Motor Construction	Compressor Min. Speed for Trip [Hz]	Hz	4-17	Torque Limit Generator Mode	Pulse Output Max Freq #29
1-1*	VVC+ PM	Compressor Min. Speed for Trip [RPM]	RPM	4-18	Current Limit	Terminal X30/6 Pulse Output Variable
1-14	Damping Gain	Compressor Min. Speed for Trip [Hz]	Hz	4-19	Max Output Frequency	Pulse Output Max Freq #X30/6
1-15	Low Speed Filter Time Const.	Motor Temperature	°C	4-5*	Adj. Warnings	I/O Options
1-16	High Speed Filter Time Const.	Motor Thermal Protection	°C	4-50	Warning Current Low	5-80 AHF Cap Reconnect Delay
1-17	Voltage filter time const.	Motor External Fan	°C	4-51	Warning Current High	5-9* Bus Controlled
1-2*	Motor Data	Thermistor Source	°C	4-52	Warning Speed Low	5-90 Digital & Relay Bus Control
1-20	Motor Power [kW]	DC Brake	°C	4-53	Warning Speed High	5-93 Pulse Out #27 Bus Control
1-21	Motor Power [HP]	DC Brake	°C	4-54	Warning Reference Low	5-94 Pulse Out #29 Timeout Preset
1-22	Motor Voltage	DC Hold/Preheat Current	A	4-55	Warning Reference High	5-95 Pulse Out #27 Bus Control
1-23	Motor Frequency	DC Brake Current	A	4-56	Warning Feedback Low	5-96 Pulse Out #29 Timeout Preset
1-24	Motor Current	DC Braking Time	s	4-57	Warning Feedback High	5-97 Pulse Out #X30/6 Bus Control
1-25	Motor Nominal Speed	DC Brake Cut-in Speed [RPM]	RPM	4-58	Missing Motor Phase Function	5-98 Pulse Out #X30/6 Timeout Preset
2-2*	LCP Display	DC Brake Cut-in Speed [Hz]	Hz	4-6*	Speed Bypass	6-** Analog In/Out
2-00	Motor Cont. Rated Torque	Parking Current	A	4-60	Bypass Speed From [RPM]	6-0* Analog I/O Mode
2-01	Motor Rotation Check	Parking Time	s	4-61	Bypass Speed From [Hz]	6-00 Live Zero Timeout Time
2-02	Motor Nominal Speed	Brake Energy Funct.	kJ	4-62	Bypass Speed To [RPM]	6-01 Live Zero Timeout Function
2-03	Motor Current	Brake Function	A	4-63	Bypass Speed To [Hz]	6-02 Fire Mode Live Zero Timeout Function
2-04	Motor Nominal Speed	AC Brake Max. Current	A	4-64	Semi-Auto Bypass Set-up	Function
2-06	Motor Cont. Rated Torque	Over-voltage Control	V	5-**	Digital In/Out	6-1* Analog Input 53
2-07	Motor Rotation Check	Reference / Ramps	Hz	5-0*	Digital I/O mode	6-10 Terminal 53 Low Voltage
2-1*	Automatic Motor Adaptation (AMA)	Reference Limits	Hz	5-00	Digital I/O Mode	6-11 Terminal 53 High Voltage
1-3*	Add. Motor Data	Minimum Reference	Hz	5-01	Terminal 27 Mode	6-12 Terminal 53 Low Current
1-30	Stator Resistance (Rs)	Maximum Reference	Hz	5-02	Terminal 29 Mode	6-13 Terminal 53 High Current
1-31	Rotor Resistance (Rr)	Reference Function	Hz	5-1*	Digital Inputs	6-14 Terminal 53 Low Ref./Feedb. Value
1-36	Main Reactance (Xh)	References	Hz	5-10	Terminal 18 Digital Input	6-15 Terminal 53 High Ref./Feedb. Value
1-37	Iron Loss Resistance (Rfe)	Preset Reference	Hz	5-11	Terminal 19 Digital Input	6-16 Terminal 53 Filter Time Constant
1-39	Motor Poles	Jog Speed [Hz]	Hz	5-12	Terminal 27 Digital Input	6-17 Terminal 53 Live Zero
1-40	d-axis Inductance (Ld)	Reference Site	Hz	5-13	Terminal 29 Digital Input	6-2* Analog Input 54
1-46	Position Detection Gain	Preset Relative Reference	Hz	5-14	Terminal 32 Digital Input	6-20 Terminal 54 Low Voltage
1-5*	Load-Indep. Setting	Reference 1 Source	Hz	5-15	Terminal 33 Digital Input	6-21 Terminal 54 High Voltage
1-50	Motor Magnetizing at Zero Speed	Reference 2 Source	Hz	5-16	Terminal X30/2 Digital Input	6-22 Terminal 54 Low Current
1-51	Min Speed Normal Magnetizing [RPM]	Reference 3 Source	Hz	5-17	Terminal X30/3 Digital Input	6-23 Terminal 54 High Current
1-52	Min Speed Normal Magnetizing [Hz]	Ramp 1	Hz	5-18	Terminal X30/4 Digital Input	6-24 Terminal 54 Low Ref./Feedb. Value
1-58	Flystart Test Pulses Current	Ramp 1 Ramp-up Time	s	5-19	Terminal 37 Safe Stop	6-25 Terminal 54 High Ref./Feedb. Value
1-59	Flystart Test Pulses Frequency	Ramp 1 Ramp-down Time	s	5-3*	Digital Outputs	6-26 Terminal 54 Filter Time Constant
1-6*	Copy/Save	Ramp 2	Hz	5-30	Terminal 27 Digital Output	6-27 Terminal 54 Live Zero
1-60	LCP Copy	Ramp 2 Ramp-up Time	s	5-31	Terminal 29 Digital Output	6-3* Analog Input X30/11
1-61	Set-up Copy	Ramp 2 Ramp-down Time	s	5-32	Term X30/6 Digi Out (MCB 101)	6-30 Terminal X30/11 Low Voltage
1-62	Password	Other Ramps	Hz	5-33	Term X30/7 Digi Out (MCB 101)	6-31 Terminal X30/11 High Voltage
1-63	Main Menu Password	Jog Ramp Time	s	5-4*	Relays	6-34 Term. X30/11 Low Ref./Feedb. Value
1-64	Access to Main Menu w/o Password	Quick Stop Ramp Time	s	5-40	Function Relay	6-35 Term. X30/11 High Ref./Feedb. Value
1-65	Personal Menu Password	Starting Ramp-up Time	s	5-41	On Delay, Relay	6-36 Term. X30/11 Filter Time Constant
1-66	Access to Personal Menu w/o Password	Digital Pot. meter	Hz	5-42	Off Delay, Relay	6-37 Term. X30/11 Live Zero
1-66	Password	Step Size	Hz	5-5*	Pulse Input	6-4* Analog Input X30/12
1-7*	Bus Password Access	Ramp Time	s	5-50	Term. 29 Low Frequency	6-40 Terminal X30/12 Low Voltage
1-70	PM Start Mode	Power Restore	Hz	5-51	Term. 29 High Frequency	6-41 Terminal X30/12 High Voltage
1-71	Start Delay	Maximum Limit	Hz	5-52	Term. 29 Low Ref./Feedb. Value	6-44 Term. X30/12 Low Ref./Feedb. Value
1-72	Date Format	Minimum Limit	Hz	5-53	Term. 33 High Frequency	6-45 Term. X30/12 High Ref./Feedb. Value
1-73	Time Format	Motor Limits	Hz	5-54	Term. 33 Low Frequency	6-46 Term. X30/12 Filter Time Constant
1-74	DST/Summertime Start	Motor Warnings	Hz	5-55	Term. 33 High Frequency	6-47 Term. X30/12 Live Zero
1-75	Start Speed [Hz]	Motor Limits	Hz	5-56	Term. 33 Low Ref./Feedb. Value	6-5* Analog Output 42
1-76	DST/Summertime End	Motor Speed Direction	Hz	5-57	Term. 33 High Ref./Feedb. Value	6-50 Terminal 42 Output
1-77	Clock Fault	Compressor Start Max Speed [RPM]	RPM	4-1*	Motor Speed	6-51 Terminal 42 Output Min Scale
1-78	Working Days	Compressor Start Max Speed [Hz]	Hz	4-10	Motor Speed Low Limit [RPM]	6-52 Terminal 42 Output Max Scale
1-79	Additional Working Days	Compressor Start Max Time to Trip	s	4-11	Motor Speed Low Limit [Hz]	6-53 Terminal 42 Output Bus Control
1-8*	Stop Adjustments	Function at Stop	Hz	4-12	Motor Speed Low Limit [Hz]	
1-80	Date and Time Readout					
1-**	Load and Motor					

6-54	Terminal 42 Output Timeout Preset	9-27	Parameter Edit	13-3*	Smart Logic	15-0*	Operating Data	15-92	Defined Parameters
6-60	Analog Output X30/8	9-28	Process Control	13-0*	SLC Settings	15-00	Operating hours	15-93	Modified Parameters
6-61	Terminal X30/8 Output	9-44	Fault Message Counter	13-00	SL Controller Mode	15-01	Running Hours	15-99	Parameter Metadata
6-62	Terminal X30/8 Min. Scale	9-45	Fault Code	13-01	Start Event	15-02	kWh Counter	16-0*	Data Readouts
6-63	Terminal X30/8 Max. Scale	9-47	Fault Number	13-02	Stop Event	15-03	Power-ups	16-00	General Status
6-64	Terminal X30/8 Output Bus Control Preset	9-52	Fault Situation Counter	13-03	Reset SLC	15-04	Over Temps	16-01	Control Word
		9-53	Profibus Warning Word	13-1*	Comparators	15-05	Over Volts	16-02	Reference [Unit]
		9-63	Actual Baud Rate	13-10	Comparator Operand	15-06	Reset kWh Counter	16-03	Status Word
		9-64	Device Identification	13-11	Comparator Operator	15-07	Reset Running Hours Counter	16-05	Main Actual Value [%]
		9-65	Profile Number	13-12	Comparator Value	15-08	Number of Starts	16-09	Custom Readout
		9-67	Control Word 1	13-2*	Timers	15-1*	Data Log Settings	16-1*	Motor Status
		9-68	Status Word 1	13-20	SL Controller Timer	15-10	Logging Source	16-10	Power [kW]
		9-71	Profibus Save Data Values	13-4*	Logic Rules	15-11	Logging Interval	16-11	Power [hp]
		9-72	ProfibusDriveReset	13-40	Logic Rule Boolean 1	15-12	Trigger Event	16-12	Motor voltage
		9-80	Defined Parameters (1)	13-41	Logic Rule Operator 1	15-13	Logging Mode	16-13	Frequency
		9-81	Defined Parameters (2)	13-42	Logic Rule Boolean 2	15-14	Samples Before Trigger	16-14	Motor current
		9-82	Defined Parameters (3)	13-43	Logic Rule Operator 2	15-2*	Historic Log	16-15	Frequency [%]
		9-83	Defined Parameters (4)	13-44	Logic Rule Boolean 3	15-20	Historic Log: Event	16-16	Torque [Nm]
		9-84	Defined Parameters (5)	13-5*	States	15-21	Historic Log: Value	16-17	Speed [RPM]
		9-90	Changed Parameters (1)	13-51	SL Controller Event	15-22	Historic Log: Time	16-18	Motor Thermal
		9-91	Changed Parameters (2)	13-52	SL Controller Action	15-23	Historic Log: Date and Time	16-22	Torque [%]
		9-92	Changed Parameters (3)	14-*	Special Functions	15-3*	Alarm Log	16-3*	Drive Status
		9-93	Changed Parameters (4)	14-0*	Inverter Switching	15-30	Alarm Log: Error Code	16-30	DC Link Voltage
		9-94	Changed parameters (5)	14-00	Switching Pattern	15-31	Alarm Log: Value	16-32	Brake Energy /s
		10-*	CAN Fields	14-01	Switching Frequency	15-32	Alarm Log: Time	16-33	Brake Energy /2 min
		10-0*	Common Settings	14-03	Overmodulation	15-33	Alarm Log: Date and Time	16-34	Heatsink Temp.
		10-00	CAN Protocol	14-04	PWM Random	15-34	Alarm Log: Status	16-35	Inverter Thermal
		10-01	Baud Rate Select	14-1*	Mains On/Off	15-35	Alarm Log: Alarm Text	16-36	Inv. Nom. Current
		10-02	MAC ID	14-12	Function at Mains Imbalance	15-40	FC Type	16-37	Inv. Max. Current
		10-05	Readout Transmit Error Counter	14-2*	Reset Functions	15-41	Power Section	16-38	SL Controller State
		10-06	Readout Receive Error Counter	14-20	Reset Mode	15-42	Voltage	16-39	Control Card Temp.
		10-07	Readout Bus Off Counter	14-21	Automatic Restart Time	15-43	Software Version	16-40	Logging Buffer Full
		10-1*	DeviceNet	14-22	Operation Mode	15-44	Ordered Typecode String	16-41	LCP Bottom Statusline
		10-10	Process Data Type Selection	14-23	Typecode Setting	15-45	Actual Typecode String	16-49	Current Fault Source
		10-11	Process Data Config Write	14-25	Trip Delay at Torque Limit	15-46	Adj Freq Dr Ordering No.	16-5*	Ref. & Feedb.
		10-12	Process Data Config Read	14-26	Trip Delay at Inverter Fault	15-47	Power Card Ordering No.	16-50	External Reference
		10-13	Warning Parameter	14-28	Production Settings	15-48	LCP ID Num.	16-52	Feedback [Unit]
		10-14	Net Reference	14-29	Service Code	15-49	SW ID Control Card	16-53	Digi Pot Reference
		10-15	Net Control	14-30	Current Lim Ctrl, Proportional Gain	15-50	SW ID Power Card	16-54	Feedback 1 [Unit]
		10-2*	COS Filters	14-31	Current Lim Ctrl, Integration Time	15-51	Adj Freq Dr Serial No.	16-55	Feedback 2 [Unit]
		10-20	COS Filter 1	14-32	Current Lim Ctrl, Filter Time	15-53	Power Card Serial Number	16-56	Feedback 3 [Unit]
		10-21	COS Filter 2	14-40	VT Level	15-60	Option Mounted	16-60	Digital Input
		10-22	COS Filter 3	14-41	AEO Minimum Magnetization	15-61	Option SW Version	16-61	Terminal 53 Switch Setting
		10-23	COS Filter 4	14-42	Minimum AEO Frequency	15-62	Option Ordering No	16-62	Analog Input 53
		10-3*	Parameter Access	14-43	Motor Cos-Phi	15-63	Option Serial No	16-63	Terminal 54 Switch Setting
		10-30	Array Index	14-5*	Environment	15-70	Option in Slot A	16-64	Analog Input 54
		10-31	Store Data Values	14-50	RFI 1	15-71	Slot A Option SW Version	16-65	Analog Output 42 [mA]
		10-32	Devicenet Revision	14-51	DC Link Compensation	15-72	Option in Slot B	16-66	Digital Output [bin]
		10-33	Store Always	14-52	Fan Control	15-73	Slot B Option SW Version	16-68	Pulse Input #29 [Hz]
		10-34	Devicenet Product Code	14-53	Fan Monitor	15-74	Option in Slot C0	16-69	Pulse Output #27 [Hz]
		10-39	Devicenet F Parameters	14-55	Output Filter	15-75	Slot C0/E0 Option SW Version	16-70	Pulse Output #29 [Hz]
		11-*	Profibus	14-59	Actual Number of Inverter Units	15-76	Option in Slot C1	16-71	Relay Output [bin]
		11-2*	LON Param. Access	14-60	Auto Derate	15-8*	Operating Data II	16-72	Counter A
		11-21	Store Data Values	14-61	Function at Overtemperature	15-80	Fan Running Hours	16-73	Counter B
		11-9*	AK LonWorks	14-62	Inv. Overload Derate Current	15-81	Preset Fan Running Hours	16-75	Analog In X30/11
		11-90	VLT Network Address	15-*	Drive Information	15-9*	Parameter Info	16-76	Analog In X30/12
		11-91	AK Service Pin						
		11-98	Telegram Selection						
		11-99	Alarm Status						

16-77	Analog Out X30/8 [mA]	21-50	Ext. 3 Ref./Feedback Unit	22-80	Flow Compensation	25-26	++ Zone Delay
16-8*	Fieldbus & FC Port	21-51	Ext. 3 Minimum Reference	22-81	Square-linear Curve Approximation	25-27	-- Zone Delay
16-80	Fieldbus CTW 1	21-52	Ext. 3 Maximum Reference	22-82	Work Point Calculation	25-3*	Staging Functions
16-82	Fieldbus REF 1	21-53	Ext. 3 Reference Source	22-83	Speed at No-Flow [RPM]	25-30	Destage At No-Flow
16-84	Comm. Option Status	21-54	Ext. 3 Feedback Source	22-84	Speed at No-Flow [Hz]	25-31	Stage Function
16-85	FC Port CTW 1	21-55	Ext. 3 Setpoint	22-85	Speed at Design Point [RPM]	25-32	Stage Function Time
16-86	FC Port REF 1	21-57	Ext. 3 Reference [Unit]	22-86	Speed at Design Point [Hz]	25-33	Destage Function
16-9*	Diagnosis Readouts	21-58	Ext. 3 Feedback [Unit]	22-87	Pressure at No-Flow Speed	25-34	Destage Function Time
16-90	Alarm Word	21-59	Ext. 3 Output [%]	22-88	Pressure at Rated Speed	25-4*	Staging Settings
16-91	Alarm Word 2	21-6*	Ext. CL 3 PID	22-89	Flow at Design Point	25-42	Staging Threshold
16-92	Warning Word	21-60	Ext. 3 Normal/Inverse Control	22-90	Flow at Rated Speed	25-43	De-staging Threshold
16-93	Warning Word 2	21-61	Ext. 3 Proportional Gain	23-0*	Time-based Functions	25-44	Staging Speed [RPM]
16-94	Ext. Status Word	21-62	Ext. 3 Integral Time	23-0*	Timed Actions	25-45	Staging Speed [Hz]
16-95	Ext. Status Word 2	21-63	Ext. 3 Differentiation Time	23-00	ON Time	25-46	De-staging Speed [RPM]
16-96	Maintenance Word	21-64	Ext. 3 Dif. Gain Limit	23-01	ON Action	25-47	De-staging Speed [Hz]
18-0*	Maintenance Log	22-0*	Application Functions	23-02	OFF Time	25-8*	Status
18-00	Maintenance Log: Item	22-00	External Interlock Delay	23-03	OFF Action	25-80	Pack Status
18-01	Maintenance Log: Action	22-00	No-Flow Detection	23-04	Occurrence	25-81	Compressor Status
18-02	Maintenance Log: Time	22-20	Low Power Auto Set-up	23-10	Maintenance	25-82	Lead Compressor
18-03	Maintenance Log: Date and Time	22-21	Low Power Detection	23-11	Maintenance Item	25-83	Relay Status
18-1*	Fire Mode Log	22-22	Low Speed Detection	23-10	Maintenance Action	25-84	Compressor ON Time
18-10	Fire Mode Log: Event	22-23	No-Flow Function	23-12	Maintenance Time Base	25-85	Relay ON Time
18-11	Fire Mode Log: Time	22-24	No-Flow Delay	23-13	Maintenance Time Interval	25-86	Reset Relay Counters
18-12	Fire Mode Log: Date and Time	22-24	Dry Pump Function	23-14	Maintenance Date and Time	25-87	Inverse Interlock
18-3*	Inputs & Outputs	22-27	Dry Pump Delay	23-15	Reset Maintenance Word	25-88	Pack capacity [%]
18-30	Analog Input X42/1	22-30	No-Flow Power Tuning	23-16	Maintenance Text	25-9*	Service
18-31	Analog Input X42/3	22-30	No-Flow Power	23-16	Maintenance Text	25-90	Compressor Interlock
18-32	Analog Input X42/5	22-31	Power Correction Factor	23-5*	Energy Log	25-91	Manual Alternation
18-33	Analog Out X42/7 [V]	22-32	Low Speed [RPM]	23-50	Energy Log Resolution	26-0*	Analog I/O Option
18-34	Analog Out X42/9 [V]	22-33	Low Speed [Hz]	23-51	Period Start	26-00	Terminal X42/1 Mode
18-35	Analog Out X42/11 [V]	22-34	Low Speed Power [kW]	23-53	Energy Log	26-01	Terminal X42/3 Mode
20-0*	Drive Closed-loop	22-35	Low Speed Power [HP]	23-54	Reset Energy Log	26-02	Terminal X42/5 Mode
20-00	Feedback 1 Source	22-36	High Speed [RPM]	23-6*	Trending	26-1*	Analog Input X42/1
20-01	Feedback 1 Conversion Unit	22-37	High Speed [Hz]	23-60	Trend Variable	26-10	Terminal X42/1 Low Voltage
20-02	Feedback 1 Source Unit	22-38	High Speed Power [kW]	23-61	Continuous Bin Data	26-11	Terminal X42/1 High Voltage
20-03	Feedback 2 Source	22-39	High Speed Power [HP]	23-62	Timed Bin Data	26-14	Term. X42/1 Low Ref./Feedb. Value
20-04	Feedback 2 Conversion Unit	22-4*	Sleep Mode	23-64	Timed Period Stop	26-15	Term. X42/1 High Ref./Feedb. Value
20-05	Feedback 2 Source Unit	22-40	Minimum Run Time	23-65	Minimum Bin Value	26-16	Term. X42/1 Filter Time Constant
20-06	Feedback 3 Source	22-41	Minimum Sleep Time	23-66	Reset Continuous Bin Data	26-17	Term. X42/1 Live Zero
20-07	Feedback 3 Conversion Unit	22-42	Wake-up Speed [RPM]	23-67	Reset Timed Bin Data	26-2*	Analog Input X42/3
20-08	Feedback 3 Source Unit	22-43	Wake-up Speed [Hz]	23-80	Power Reference Factor	26-20	Terminal X42/3 Low Voltage
20-12	Reference/Feedback Unit	22-44	Wake-up Ref./FB Difference	23-81	Energy Cost	26-21	Terminal X42/3 High Voltage
20-2*	Feedback & Setpoint	22-45	Setpoint Boost	23-82	Investment	26-24	Term. X42/3 Low Ref./Feedb. Value
20-20	Feedback Function	22-46	Maximum Boost Time	23-83	Energy Savings	26-25	Term. X42/3 High Ref./Feedb. Value
20-21	Setpoint 1	22-50	End of Curve Function	23-84	Cost Savings	26-26	Term. X42/3 Filter Time Constant
20-22	Setpoint 2	22-51	End of Curve Delay	25-2*	Cascade Controller	26-27	Term. X42/3 Live Zero
20-23	Setpoint 3	22-51	End of Curve Delay	25-0*	System Settings	26-30	Terminal X42/5 Low Voltage
20-25	Setpoint: Type	22-60	Broken Belt Function	25-00	Pack Controller	26-31	Terminal X42/5 High Voltage
20-3*	Feedback Adv. Conv	22-62	Broken Belt Torque	25-04	Compressor Cycling	26-34	Term. X42/5 Low Ref./Feedb. Value
20-30	Refrigerant	22-62	Broken Belt Delay	25-06	Number Of Pumps	26-35	Term. X42/5 High Ref./Feedb. Value
20-31	User-defined Refrigerant A1	22-7*	Short Cycle Protection	25-2*	Bandwidth Settings	26-36	Term. X42/5 Filter Time Constant
20-32	User-defined Refrigerant A2	22-75	Short Cycle Protection	25-20	Neutral Zone [unit]	26-37	Term. X42/5 Live Zero
20-33	User-defined Refrigerant A3	22-76	Interval between Starts	25-21	+ Zone [unit]	26-40	Terminal X42/7 Output
20-4*	Thermostat/Pressostat	22-77	Minimum Run Time	25-22	- Zone [unit]	26-41	Terminal X42/7 Min. Scale
20-40	Thermostat/Pressostat Function	22-78	Minimum Run Time Override	25-23	Fixed Speed neutral Zone (unit)	26-42	Terminal X42/7 Max. Scale
20-41	Cut-out Value	22-79	Minimum Run Time Override Value	25-24	+ Zone Delay	26-43	Terminal X42/7 Output Bus Control
20-42	Cut-in Value	22-8*	Flow Compensation	25-25	SBW De-staging Delay		

26-44	Terminal X42/7 Output Timeout Preset
26-5*	Analog Output X42/9
26-50	Terminal X42/9 Output
26-51	Terminal X42/9 Min. Scale
26-52	Terminal X42/9 Max. Scale
26-53	Terminal X42/9 Output Bus Control
26-54	Terminal X42/9 Output Timeout Preset
26-6*	Analog Output X42/11
26-60	Terminal X42/11 Output
26-61	Terminal X42/11 Min. Scale
26-62	Terminal X42/11 Max. Scale
26-63	Terminal X42/11 Output Bus Control
26-64	Terminal X42/11 Output Timeout Preset
28-*	Compressor Functions
28-2*	Discharge Temperature Monitor
28-20	Temperature Source
28-21	Temperature Unit
28-24	Warning Level
28-25	Warning Action
28-26	Emergency Level
28-27	Discharge Temperature
28-7*	Day/Night Settings
28-71	Day/Night Bus Indicator
28-72	Enable Day/Night Via Bus
28-73	Night Setback
28-74	Night Speed Drop [RPM]
28-75	Night Speed Drop Override
28-76	Night Speed Drop [Hz]
28-8*	P0 Optimization
28-81	qP0 Offset
28-82	P0
28-83	P0 Setpoint
28-84	P0 Reference
28-85	P0 Minimum Reference
28-86	P0 Maximum Reference
28-87	Most Loaded Controller
28-9*	Injection Control
28-90	Injection On
28-91	Delayed Compressor Start
30-*	Special Features
30-2*	Adv. Start Adjust
30-22	Locked Rotor Protection
30-23	Locked Rotor Detection Time [s]
31-*	Bypass Option
31-00	Bypass Mode
31-01	Bypass Start Time Delay
31-02	Bypass Trip Time Delay
31-03	Test Mode Activation
31-10	Bypass Status Word
31-11	Bypass Running Hours
31-19	Remote Bypass Activation

6 Application Set-up Examples

6.1 Introduction

NOTICE!

When the optional Safe torque off feature is used, a jumper wire may be required between terminal 12 (or 13) and terminal 37 for the adjustable frequency drive to operate when using factory default programming values.

The examples in this section are intended as a quick reference for common applications.

- Parameter settings are the regional default values unless otherwise indicated (selected in *0-03 Regional Settings*).
- Parameters associated with the terminals and their settings are shown next to the drawings.
- Where switch settings for analog terminals A53 or A54 are required, these are also shown.

6.2 Set-up Examples

6.2.1 Compressor

The wizard guides the user through the set-up of a refrigeration compressor asking for input data about the compressor and the refrigeration system on which the adjustable frequency drive will be running. All terminology and units used within the wizard are common refrigeration type and set-up is thus completed in 10 to 15 easy steps using just two keys of the LCP.

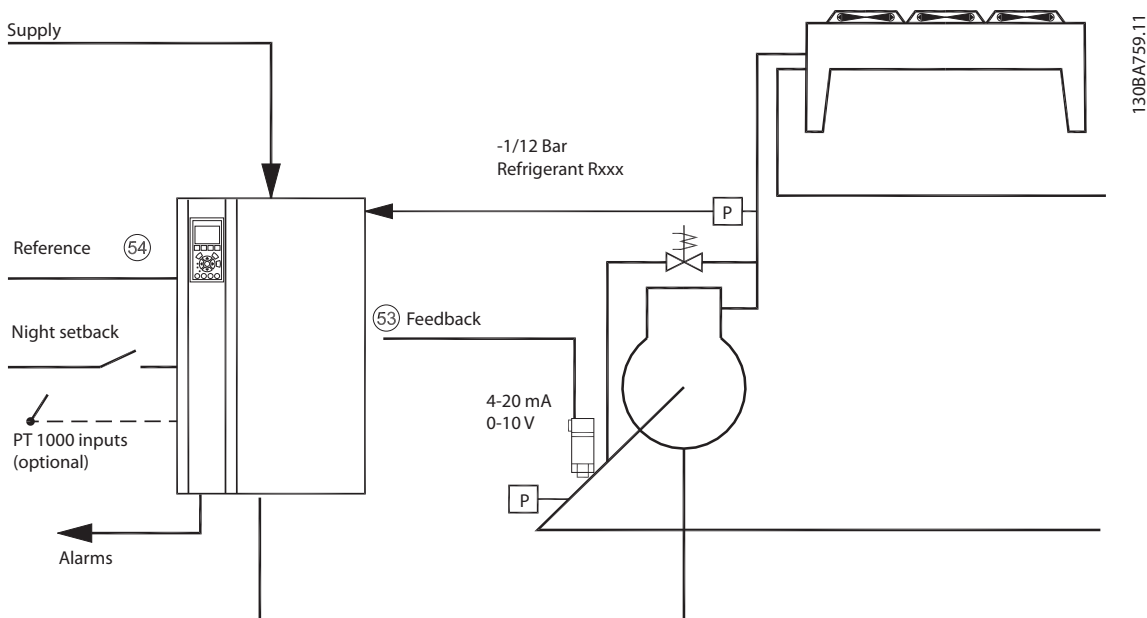

Figure 6.1 Standard Drawing of "Compressor with Internal Control"

Wizard input:

- Bypass valve
- Recycling time (start to start)
- Min. Hz
- Max. Hz
- Setpoint
- Cut in/cut out
- 400/230 V AC
- Amps
- RPM

6.2.2 Single or Multiple Fans or Pumps

6

The wizard guides the user through the process of setting up a refrigeration condenser fan or pump. Enter data about the condenser or pump and the refrigeration system on which the adjustable frequency drive will be running. All terminology and units used within the wizard are common refrigeration type and set-up is thus completed in 10 to 15 easy steps using two keys on the LCP.

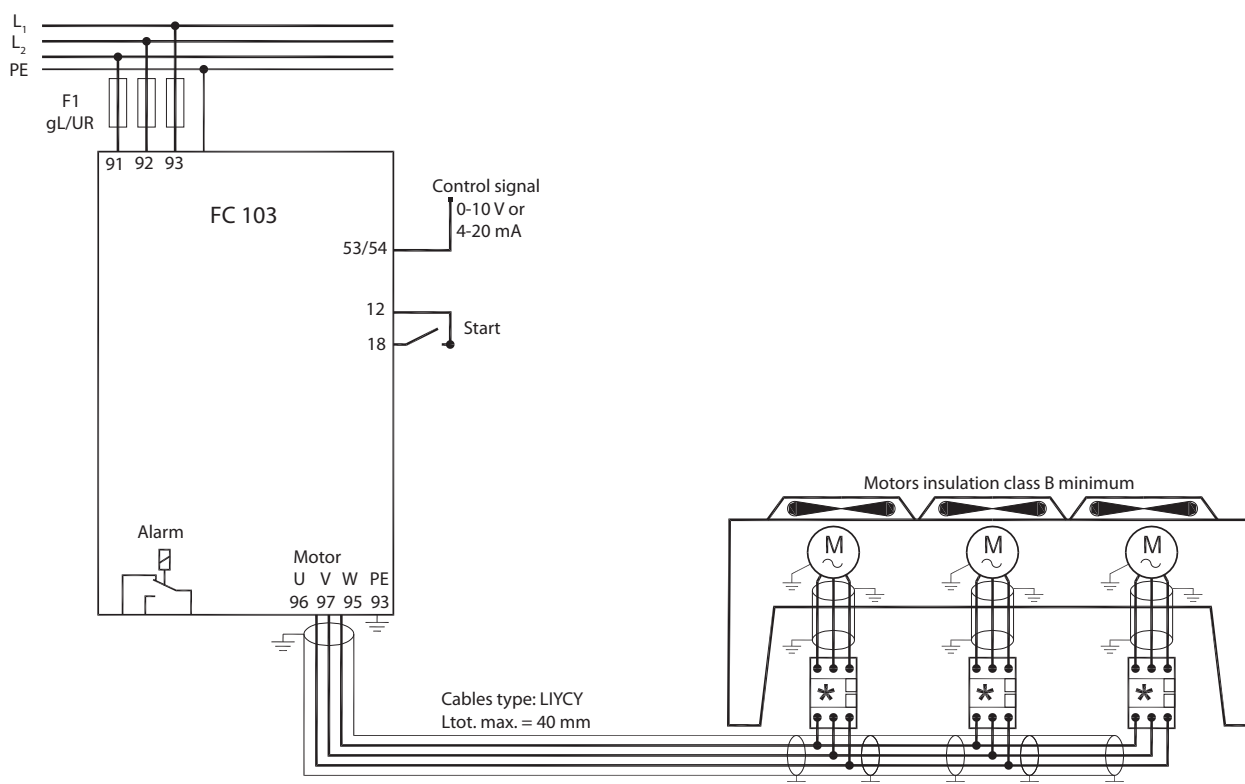

130BA761.11

Figure 6.2 Speed Control Using Analog Reference (Open-loop) – Single Fan or Pump/Multiple Fans or Pumps in Parallel

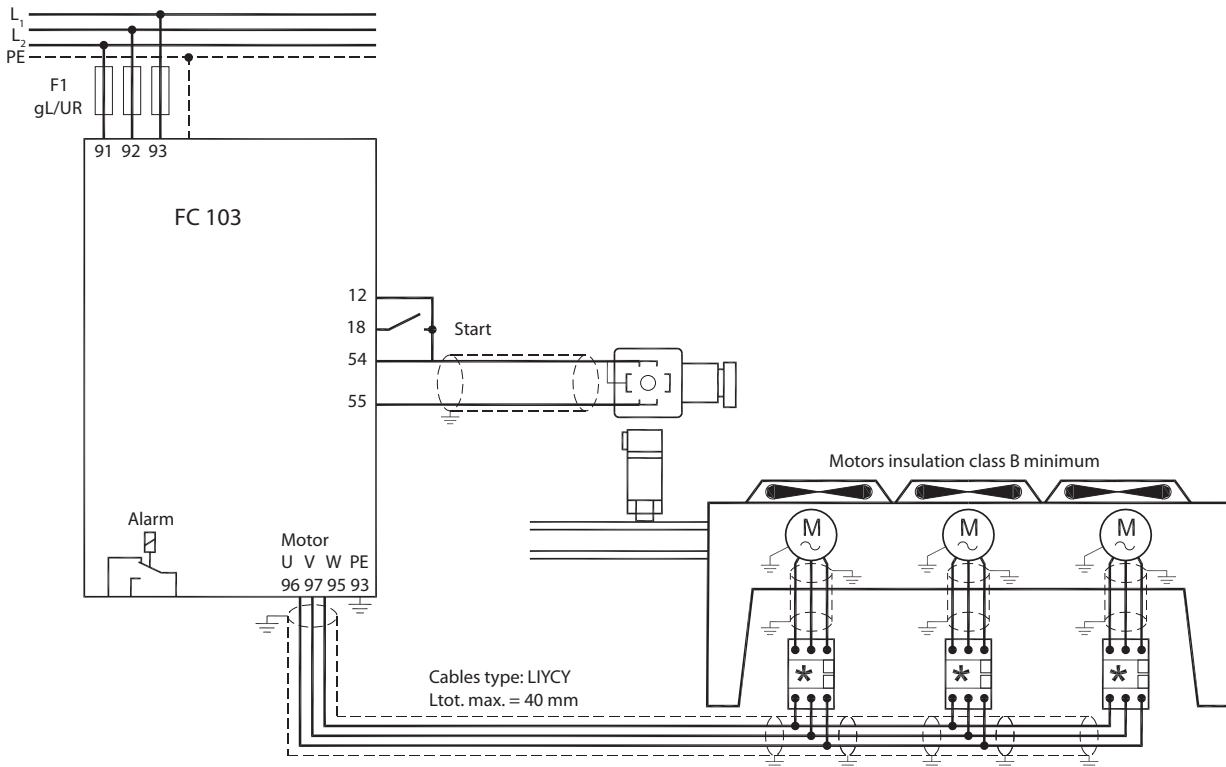

130BA760.11

6

Figure 6.3 Pressure Control in Closed-loop – Stand Alone System – Single Fan or Pump/Multiple Fans or Pumps in Parallel

6.2.3 Compressor Pack

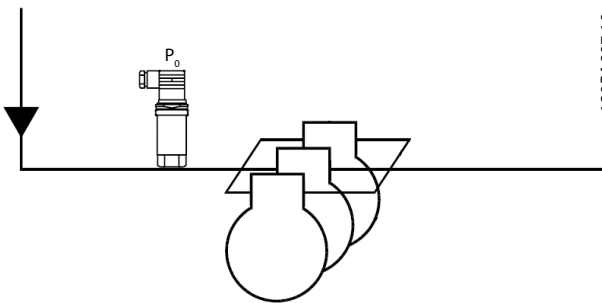

130BA807.10

Figure 6.4 P₀ Pressure Transmitter

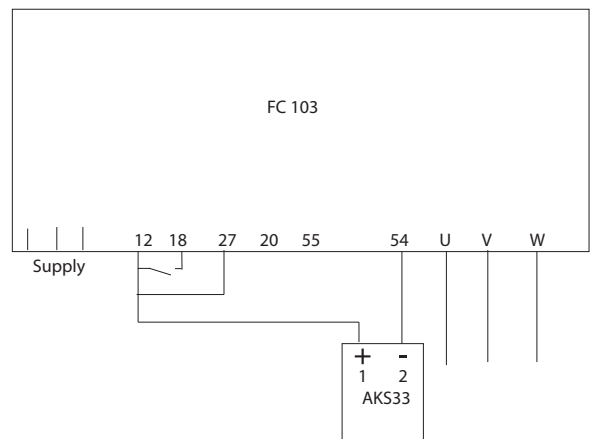

130BA808.11

Figure 6.5 How to Connect the FC 103 and AKS33 for Closed-loop Applications

NOTICE!

To find out which parameters are relevant, run the wizard.

7 Status Messages

7.1 Status Display

When the adjustable frequency drive is in status mode, status messages are generated automatically and appear in the bottom line of the display (see *Figure 7.1*).

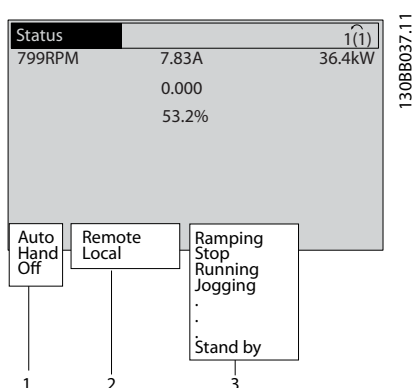

Figure 7.1 Status Display

1	Operation Mode (see <i>Table 7.2</i>)
2	Reference Site (see <i>Table 7.3</i>)
3	Operation Status (see <i>Table 7.4</i>)

Table 7.1 Legend to *Figure 7.1*

7.2 Status Message Definitions

Tables *Table 7.2* to *Table 7.4* define the meaning of the displayed status messages.

Off	The adjustable frequency drive does not react to any control signal until [Auto On] or [Hand On] is pressed.
Auto On	The adjustable frequency drive is controlled from the control terminals and/or the serial communication.
	The adjustable frequency drive can be controlled by the navigation keys on the LCP. Stop commands, reset, reversing, DC brake, and other signals applied to the control terminals can override local control.

Table 7.2 Operation Mode

Remote	The speed reference is given from external signals, serial communication, or internal preset references.
Local	The adjustable frequency drive uses [Hand On] control or reference values from the LCP.

Table 7.3 Reference Site

AC Brake	AC Brake was selected in <i>2-10 Brake Function</i> . The AC brake over-magnetizes the motor to achieve a controlled slow-down.
AMA finish OK	Automatic motor adaptation (AMA) was carried out successfully.
AMA ready	AMA is ready to start. Press [Hand On] to start.
AMA running	AMA process is in progress.
Braking	The brake chopper is in operation. Generative energy is absorbed by the brake resistor.
Braking max.	The brake chopper is in operation. The power limit for the brake resistor defined in <i>2-12 Brake Power Limit (kW)</i> has been reached.
Coast	<ul style="list-style-type: none"> Coast inverse was selected as a function for a digital input (parameter group <i>5-1* Digital Inputs</i>). The corresponding terminal is not connected. Coast activated by serial communication.

Ctrl. Ramp-down	<p>Control Ramp-down was selected in <i>14-10 Mains Failure</i>.</p> <ul style="list-style-type: none"> The AC line voltage is below the value set in <i>14-11 Mains Voltage at Mains Fault</i> at line power fault. The adjustable frequency drive ramps down the motor using a controlled ramp-down.
Current High	The adjustable frequency drive output current is above the limit set in <i>4-51 Warning Current High</i> .
Current Low	The adjustable frequency drive output current is below the limit set in <i>4-52 Warning Speed Low</i> .
DC Hold	DC Hold is selected in <i>1-80 Function at Stop</i> and a stop command is active. The motor is held by a DC current set in <i>2-00 DC Hold/ Preheat Current</i> .
DC Stop	<p>The motor is held with a DC current (<i>2-01 DC Brake Current</i>) for a specified time (<i>2-02 DC Braking Time</i>).</p> <ul style="list-style-type: none"> DC Brake is activated in <i>2-03 DC Brake Cut-in Speed [RPM]</i> and a Stop command is active. DC Brake (inverse) is selected as a function for a digital input (parameter group <i>5-1* Digital Inputs</i>). The corresponding terminal is not active. The DC Brake is activated via serial communication.
Feedback high	The sum of all active feedbacks is above the feedback limit set in <i>4-57 Warning Feedback High</i> .
Feedback low	The sum of all active feedbacks is below the feedback limit set in <i>4-56 Warning Feedback Low</i> .
Freeze output	<p>The remote reference is active, which holds the present speed.</p> <ul style="list-style-type: none"> Freeze output was selected as a function for a digital input (parameter group <i>5-1* Digital Inputs</i>). The corresponding terminal is active. Speed control is only possible via the terminal functions Speed Up and Slow. Hold ramp is activated via serial communication.
Freeze output request	A freeze output command has been given, but the motor will remain stopped until a run permissive signal is received.

Freeze ref.	<i>Freeze Reference</i> was chosen as a function for a digital input (parameter group <i>5-1* Digital Inputs</i>). The corresponding terminal is active. The adjustable frequency drive saves the actual reference. Changing the reference is now only possible via terminal functions Speed Up and Slow.
Jog request	A jog command has been given, but the motor will be stopped until a run permissive signal is received via a digital input.
Jogging	<p>The motor is running as programmed in <i>3-19 Jog Speed [RPM]</i>.</p> <ul style="list-style-type: none"> Jog was selected as function for a digital input (parameter group <i>5-1* Digital Inputs</i>). The corresponding terminal (e.g. Terminal 29) is active. The Jog function is activated via the serial communication. The Jog function was selected as a reaction for a monitoring function (e.g., No signal). The monitoring function is active.
Motor check	In <i>1-80 Function at Stop, Motor Check</i> was selected. A stop command is active. To ensure that a motor is connected to the adjustable frequency drive, a permanent test current is applied to the motor.
Over Voltage Control (OVC)	<i>Overvoltage</i> control was activated in <i>2-17 Overvoltage Control, [2] Enabled</i> . The connected motor is supplying the adjustable frequency drive with generative energy. Overvoltage control adjusts the V/Hz ratio to run the motor in controlled mode and to prevent the adjustable frequency drive from tripping.
PowerUnit Off	(For adjustable frequency drives with an external 24 V power supply installed only.) Line power supply to the adjustable frequency drive is removed, but the control card is supplied by the external 24 V.
Protection md	<p>Protection mode is active. The unit has detected a critical status (an overcurrent or overvoltage).</p> <ul style="list-style-type: none"> To avoid tripping, switching frequency is reduced to 4 kHz If possible, Protection mode ends after approximately 10 s Protection mode can be restricted in <i>14-26 Trip Delay at Inverter Fault</i>

QStop	<p>The motor is decelerating using 3-81 <i>Quick Stop Ramp Time</i>.</p> <ul style="list-style-type: none"> • <i>Quick stop inverse</i> was chosen as a function for a digital input (parameter group 5-1* <i>Digital Inputs</i>). The corresponding terminal is not active. • The quick stop function was activated via serial communication.
Ramping	The motor is accelerating/decelerating using the active ramp-up/down. The reference, a limit value or a standstill is not yet reached.
Ref. high	The sum of all active references is above the reference limit set in 4-55 <i>Warning Reference High</i> .
Ref. low	The sum of all active references is below the reference limit set in 4-54 <i>Warning Reference Low</i> .
Run on ref.	The adjustable frequency drive is running in the reference range. The feedback value matches the setpoint value.
Run request	A start command has been given, but the motor is stopped until a run permissive signal is received via digital input.
Running	The motor is driven by the adjustable frequency drive.
Sleep Mode	The energy saving function is enabled. This means that at present the motor has stopped, but that it will restart automatically when required.
Speed high	Motor speed is above the value set in 4-53 <i>Warning Speed High</i> .
Speed low	Motor speed is below the value set in 4-52 <i>Warning Speed Low</i> .
Standby	In Auto On mode, the adjustable frequency drive will start the motor with a start signal from a digital input or serial communication.
Start delay	In 1-71 <i>Start Delay</i> , a delay starting time was set. A start command is activated and the motor will start after the start delay time expires.
Start fwd/rev	Start forward and start reverse were selected as functions for two different digital inputs (parameter group 5-1* <i>Digital Inputs</i>). The motor will start in forward or reverse depending on which corresponding terminal is activated.
Stop	The adjustable frequency drive has received a stop command from the LCP, digital input or serial communication.

Trip	An alarm occurred and the motor is stopped. Once the cause of the alarm is cleared, the adjustable frequency drive can be reset manually by pressing [Reset] or remotely by control terminals or serial communication.
Trip lock	An alarm occurred and the motor is stopped. Once the cause of the alarm is cleared, power must be cycled to the adjustable frequency drive. The adjustable frequency drive can then be reset manually by pressing [Reset] or remotely by control terminals or serial communication.

Table 7.4 Operation Status

NOTICE!

In auto/remote mode, the adjustable frequency drive requires external commands to execute functions.

8 Warnings and Alarms

8.1 System Monitoring

The adjustable frequency drive monitors the condition of its input power, output, and motor factors as well as other system performance indicators. A warning or alarm may not necessarily indicate a problem internal to the adjustable frequency drive itself. In many cases, it indicates failure conditions from input voltage, motor load or temperature, external signals, or other areas monitored by the adjustable frequency drive's internal logic. Be sure to investigate those areas exterior to the adjustable frequency drive as indicated in the alarm or warning.

8.2 Warning and Alarm Types

Warnings

A warning is issued when an alarm condition is impending or when an abnormal operating condition is present and may result in the adjustable frequency drive issuing an alarm. A warning clears by itself when the abnormal condition is removed.

Alarms

Trip

An alarm is issued when the adjustable frequency drive is tripped, that is, the adjustable frequency drive suspends operation to prevent adjustable frequency drive or system damage. The motor will coast to a stop. The adjustable frequency drive logic will continue to operate and monitor the adjustable frequency drive status. After the fault condition is remedied, the adjustable frequency drive can be reset. It will then be ready to start operation again.

A trip can be reset in any of four ways

- Press [Reset] on the LCP
- Digital reset input command
- Serial communication reset input command
- Auto reset

An alarm that causes the adjustable frequency drive to trip-lock requires that input power is cycled. The motor will coast to a stop. The adjustable frequency drive logic will continue to operate and monitor the adjustable frequency drive status. Remove input power to the adjustable frequency drive and correct the cause of the fault, then restore power. This action puts the adjustable frequency drive into a trip condition as described above and may be reset in any of those four ways.

8.3 Warning and Alarm Displays

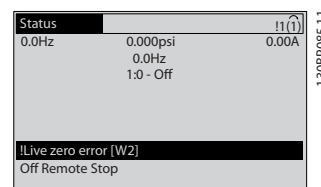

Figure 8.1 Warning Display

An alarm or trip lock alarm will flash on display along with the alarm number.

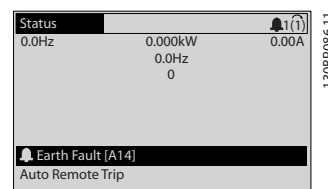

Figure 8.2 Alarm Display

In addition to the text and alarm code on the adjustable frequency drive LCP, there are three status indicator lights.

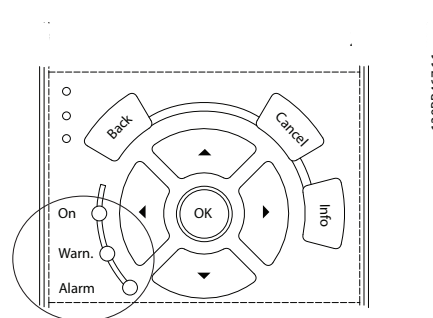

Figure 8.3 Status Indicator Lights

	Warning LED	Alarm LED
Warning	On	Off
Alarm	Off	On (Flashing)
Trip Lock	On	On (Flashing)

Table 8.1 Status Indicator Lights Explanations

8.4 Warning and Alarm Definitions

Table 8.2 defines whether a warning is issued before an alarm, and whether the alarm trips the unit or trip locks the unit.

No.	Description	Warning	Alarm/ Trip	Alarm/ Trip Lock	Parameter Reference
1	10 Volts low	X			
2	Live zero error	(X)	(X)		6-01 Live Zero Timeout Function
4	Mains phase loss	(X)	(X)	(X)	14-12 Function at Mains Imbalance
5	DC link voltage high	X			
6	DC link voltage low	X			
7	DC overvoltage	X	X		
8	DC undervoltage	X	X		
9	Inverter overloaded	X	X		
10	Motor ETR overtemperature	(X)	(X)		1-90 Motor Thermal Protection
11	Motor thermistor overtemperature	(X)	(X)		1-90 Motor Thermal Protection
12	Torque limit	X	X		
13	Overcurrent	X	X	X	
14	Ground fault	X	X	X	
15	Hardware mismatch		X	X	
16	Short Circuit		X	X	
17	Control word timeout	(X)	(X)		8-04 Control Timeout Function
18	Start Failed				
23	Internal Fan Fault	X			
24	External Fan Fault	X			14-53 Fan Monitor
25	Brake resistor short-circuited	X			
26	Brake resistor power limit	(X)	(X)		2-13 Brake Power Monitoring
27	Brake chopper short-circuited	X	X		
28	Brake check	(X)	(X)		2-15 Brake Check
29	Drive overtemperature	X	X	X	
30	Motor phase U missing	(X)	(X)	(X)	4-58 Missing Motor Phase Function
31	Motor phase V missing	(X)	(X)	(X)	4-58 Missing Motor Phase Function
32	Motor phase W missing	(X)	(X)	(X)	4-58 Missing Motor Phase Function
33	Inrush fault		X	X	
34	Fieldbus communication fault	X	X		
35	Out of frequency range	X	X		
36	Mains failure	X	X		
37	Phase Imbalance	X	X		
38	Internal fault		X	X	
39	Heatsink sensor		X	X	
40	Overload of Digital Output Terminal 27	(X)			5-00 Digital I/O Mode, 5-01 Terminal 27 Mode
41	Overload of Digital Output Terminal 29	(X)			5-00 Digital I/O Mode, 5-02 Terminal 29 Mode
42	Overload of Digital Output On X30/6	(X)			5-32 Term X30/6 Digi Out (MCB 101)
42	Overload of Digital Output On X30/7	(X)			5-33 Term X30/7 Digi Out (MCB 101)
46	Pwr. card supply		X	X	
47	24 V supply low	X	X	X	
48	1.8 V supply low		X	X	
49	Speed limit	X	(X)		1-86 Trip Speed Low [RPM]
50	AMA calibration failed		X		
51	AMA check U_{nom} and I_{nom}		X		
52	AMA low I_{nom}		X		

No.	Description	Warning	Alarm/ Trip	Alarm/ Trip Lock	Parameter Reference
53	AMA motor too big		X		
54	AMA motor too small		X		
55	AMA Parameter out of range		X		
56	AMA interrupted by user		X		
57	AMA timeout		X		
58	AMA internal fault	X	X		
59	Current limit	X			
60	External Interlock	X			
62	Output Frequency at Maximum Limit	X			
64	Voltage Limit	X			
65	Control Board Over-temperature	X	X	X	
66	Heatsink Temperature Low	X			
67	Option Configuration has Changed		X		
69	Pwr. Card Temp		X	X	
70	Illegal FC configuration			X	
71	PTC 1 Safe Stop	X	X ¹⁾		
72	Dangerous Failure			X ¹⁾	
73	Safe Stop Auto Restart				
76	Power Unit Set-up	X			
77	Reduced Power Mode				
79	Illegal PS config		X	X	
80	Drive Initialized to Default Value		X		
91	Analog input 54 wrong settings			X	
92	NoFlow	X	X		22-2* No-Flow Detection
93	Dry Pump	X	X		22-2* No-Flow Detection
94	End of Curve	X	X		22-5* End of Curve
95	Broken Belt	X	X		22-6* Broken Belt Detection
96	Start Delayed	X			22-7* Short Cycle Protection
97	Stop Delayed	X			22-7* Short Cycle Protection
98	Clock Fault	X			0-7* Clock Settings
203	Missing Motor				
204	Locked Rotor				
243	Brake IGBT	X	X		
244	Heatsink temp	X	X	X	
245	Heatsink sensor		X	X	
246	Pwr.card supply		X	X	
247	Pwr.card temp		X	X	
248	Illegal PS config		X	X	
250	New spare parts			X	
251	New Type Code		X	X	

Table 8.2 Alarm/Warning Code List

(X) *Dependent on parameter*

¹⁾ *Cannot be Auto reset via 14-20 Reset Mode*

The warning/alarm information below defines each warning/alarm condition, provides the probable cause for the condition, and details a remedy or troubleshooting procedure.

WARNING 1, 10 Volts low

The control card voltage is below 10 V from terminal 50. Remove some of the load from terminal 50, as the 10 V supply is overloaded. Max. 15 mA or minimum 590 Ω .

This condition can be caused by a short in a connected potentiometer or improper wiring of the potentiometer.

Troubleshooting

Remove the wiring from terminal 50. If the warning clears, the problem is with the customer wiring. If the warning does not clear, replace the control card.

WARNING/ALARM 2, Live zero error

This warning or alarm only appears if programmed by the user in *6-01 Live Zero Timeout Function*. The signal on one of the analog inputs is less than 50% of the minimum value programmed for that input. Broken wiring or faulty device sending the signal can cause this condition.

Troubleshooting

Check connections on all the analog input terminals. Control card terminals 53 and 54 for signals, terminal 55 common. MCB 101 terminals 11 and 12 for signals, terminal 10 common. MCB 109 terminals 1, 3, 5 for signals, terminals 2, 4, 6 common.

Check that the adjustable frequency drive programming and switch settings match the analog signal type.

Perform Input Terminal Signal Test.

WARNING/ALARM 4, Mains phase loss

A phase is missing on the supply side, or the line voltage imbalance is too high. This message also appears for a fault in the input rectifier on the adjustable frequency drive. Options are programmed at *14-12 Function at Mains Imbalance*.

Troubleshooting

Check the supply voltage and supply currents to the adjustable frequency drive.

WARNING 5, DC link voltage high

The intermediate circuit voltage (DC) is higher than the high voltage warning limit. The limit is dependent on the adjustable frequency drive voltage rating. The unit is still active.

WARNING 6, DC link voltage low

The intermediate circuit voltage (DC) is lower than the low voltage warning limit. The limit is dependent on the adjustable frequency drive voltage rating. The unit is still active.

WARNING/ALARM 7, DC overvoltage

If the intermediate circuit voltage exceeds the limit, the adjustable frequency drive trips after a time.

Troubleshooting

Connect a brake resistor

Extend the ramp time

Change the ramp type

Activate the functions in *2-10 Brake Function*

Increase *14-26 Trip Delay at Inverter Fault*

If the alarm/warning occurs during a power sag, the solution is to use kinetic backup (*14-10 Line Failure*)

WARNING/ALARM 8, DC undervoltage

If the intermediate circuit voltage (DC link) drops below the undervoltage limit, the adjustable frequency drive checks if a 24 V DC backup supply is connected. If no 24 V DC backup supply is connected, the adjustable frequency drive trips after a fixed time delay. The time delay varies with unit size.

Troubleshooting

Make sure that the supply voltage matches the adjustable frequency drive voltage.

Perform input voltage test.

Perform soft charge circuit test.

WARNING/ALARM 9, Inverter overload

The adjustable frequency drive is about to cut out because of an overload (current too high for too long). The counter for electronic, thermal inverter protection issues a warning at 98% and trips at 100%, while giving an alarm. The adjustable frequency drive *cannot* be reset until the counter is below 90%.

The fault is that the adjustable frequency drive has run with more than 100% overload for too long.

Troubleshooting

Compare the output current shown on the LCP with the adjustable frequency drive rated current.

Compare the output current shown on the LCP with measured motor current.

Display the Thermal Drive Load on the LCP and monitor the value. When running above the adjustable frequency drive continuous current rating, the counter increases. When running below the adjustable frequency drive continuous current rating, the counter decreases.

WARNING/ALARM 10, Motor overload temperature

According to the electronic thermal protection (ETR), the motor is too hot. Select whether the adjustable frequency drive issues a warning or an alarm when the counter reaches 100% in *1-90 Motor Thermal Protection*. The fault occurs when the motor runs with more than 100% overload for too long.

Troubleshooting

Check for motor overheating.

Check if the motor is mechanically overloaded.

Check that the motor current set in *1-24 Motor Current* is correct.

Ensure that motor data in parameters 1-20 to 1-25 are set correctly.

If an external fan is in use, check in *1-91 Motor External Fan* that it is selected.

Running *AMA* in *1-29 Automatic Motor Adaptation (AMA)* tunes the adjustable frequency drive to the motor more accurately and reduces thermal loading.

WARNING/ALARM 11, Motor thermistor overtemp

Check whether the thermistor is disconnected. Select whether the adjustable frequency drive issues a warning or an alarm in *1-90 Motor Thermal Protection*.

Troubleshooting

Check for motor overheating.

Check if the motor is mechanically overloaded.

When using terminal 53 or 54, check that the thermistor is connected correctly between either terminal 53 or 54 (analog voltage input) and terminal 50 (+10 V supply). Also check that the terminal switch for 53 or 54 is set for voltage. Check *1-93 Thermistor Source* selects terminal 53 or 54.

When using digital inputs 18 or 19, check that the thermistor is connected correctly between either terminal 18 or 19 (digital input PNP only) and terminal 50. Check *1-93 Thermistor Source* selects terminal 18 or 19.

WARNING/ALARM 12, Torque limit

The torque has exceeded the value in *4-16 Torque Limit Motor Mode* or the value in *4-17 Torque Limit Generator Mode*. *14-25 Trip Delay at Torque Limit* can change this from a warning only condition to a warning followed by an alarm.

Troubleshooting

If the motor torque limit is exceeded during ramp-up, extend the ramp-up time.

If the generator torque limit is exceeded during ramp-down, extend the ramp-down time.

If torque limit occurs while running, possibly increase the torque limit. Make sure that the system can operate safely at a higher torque.

Check the application for excessive current draw on the motor.

WARNING/ALARM 13, Overcurrent

The inverter peak current limit (approximately 200% of the rated current) is exceeded. The warning lasts about 1.5 s, then the adjustable frequency drive trips and issues an alarm. This fault can be caused by shock loading or quick acceleration with high inertia loads. It can also appear after kinetic backup if the acceleration during ramp-up is quick. If extended mechanical brake control is selected, trip can be reset externally.

Troubleshooting

Remove power and check if the motor shaft can be turned.

Make sure that the motor size matches the adjustable frequency drive.

Check parameters 1-20 to 1-25 for correct motor data.

ALARM 14, Ground fault

There is current from the output phases to ground, either in the cable between the adjustable frequency drive and the motor or in the motor itself.

Troubleshooting:

Remove power to the adjustable frequency drive and repair the ground fault.

Check for ground faults in the motor by measuring the resistance to ground of the motor leads and the motor with a megohmmeter.

ALARM 15, Hardware mismatch

A fitted option is not operational with the present control board hardware or software.

Record the value of the following parameters and contact your Danfoss supplier:

15-40 FC Type

15-41 Power Section

15-42 Voltage

15-43 Software Version

15-45 Actual Typecode String

15-49 SW ID Control Card

15-50 SW ID Power Card

15-60 Option Mounted

15-61 Option SW Version (for each option slot)

ALARM 16, Short circuit

There is short-circuiting in the motor or motor wiring.

Remove power to the adjustable frequency drive and repair the short circuit.

WARNING/ALARM 17, Control word timeout

There is no communication to the adjustable frequency drive.

The warning is only active when *8-04 Control Word Timeout Function* is NOT set to [0] Off.

If *8-04 Control Word Timeout Function* is set to [5] Stop and Trip, a warning appears and the adjustable frequency drive ramps down until it stops, then displays an alarm.

Troubleshooting:

Check connections on the serial communication cable.

Increase *8-03 Control Word Timeout Time*

Check the operation of the communication equipment.

Verify a proper installation based on EMC requirements.

ALARM 18, Start failed

The speed has not been able to exceed *1-77 Compressor Start Max Speed [RPM]* during start within the allowed time. (set in *1-79 Compressor Start Max Time to Trip*). This may be caused by a blocked motor.

WARNING 23, Internal fan fault

The fan warning function is an extra protective function that checks if the fan is running/mounted. The fan warning can be disabled in *14-53 Fan Monitor ([0] Disabled)*.

For the D, E, and F Frame filters, the regulated voltage to the fans is monitored.

Troubleshooting

Check for proper fan operation.

Cycle power to the adjustable frequency drive and check that the fan operates briefly at start-up.

Check the sensors on the heatsink and control card.

WARNING 24, External fan fault

The fan warning function is an extra protective function that checks if the fan is running/mounted. The fan warning can be disabled in *14-53 Fan Monitor ([0] Disabled)*.

Troubleshooting

Check for proper fan operation.

Cycle power to the adjustable frequency drive and check that the fan operates briefly at start-up.

Check the sensors on the heatsink and control card.

WARNING 25, Brake resistor short-circuit

The brake resistor is monitored during operation. If a short circuit occurs, the brake function is disabled and the warning appears. The adjustable frequency drive is still operational but without the brake function. Remove power to the adjustable frequency drive and replace the brake resistor (see *2-15 Brake Check*).

WARNING/ALARM 26, Brake resistor power limit

The power transmitted to the brake resistor is calculated as a mean value over the last 120 seconds of run time. The calculation is based on the intermediate circuit voltage and the brake resistance value set in *2-16 AC Brake Max. Current*. The warning is active when the dissipated braking energy is higher than 90% of the brake resistance power. If [2] Trip is selected in *2-13 Brake Power Monitoring*, the adjustable frequency drive trips when the dissipated braking energy reaches 100%.

WARNING/ALARM 27, Brake chopper fault

The brake transistor is monitored during operation and if a short circuit occurs, the brake function is disabled and a warning is issued. The adjustable frequency drive is still operational but, since the brake transistor has short-circuited, substantial power is transmitted to the brake resistor, even if it is inactive.

Remove power to the adjustable frequency drive and remove the brake resistor.

WARNING/ALARM 28, Brake check failed

The brake resistor is not connected or not working. Check *2-15 Brake Check*.

ALARM 29, Heatsink temp

The maximum temperature of the heatsink has been exceeded. The temperature fault will not reset until the temperature falls below a defined heatsink temperature. The trip and reset points are different based on the adjustable frequency drive power size.

Troubleshooting

Check for the following conditions.

- Ambient temperature too high.
- Motor cable too long.
- Incorrect airflow clearance above and below the adjustable frequency drive.
- Blocked airflow around the adjustable frequency drive.
- Damaged heatsink fan.
- Dirty heatsink.

ALARM 30, Motor phase U missing

Motor phase U between the adjustable frequency drive and the motor is missing.

Remove power from the adjustable frequency drive and check motor phase U.

ALARM 31, Motor phase V missing

Motor phase V between the adjustable frequency drive and the motor is missing.

Remove power from the adjustable frequency drive and check motor phase V.

ALARM 32, Motor phase W missing

Motor phase W between the adjustable frequency drive and the motor is missing.

Remove power from the adjustable frequency drive and check motor phase W.

ALARM 33, Inrush fault

Too many power-ups have occurred within a short time period. Let the unit cool to operating temperature.

WARNING/ALARM 34, Fieldbus communication fault

The serial communication bus on the communication option card is not working.

WARNING/ALARM 36, Mains failure

This warning/alarm is only active if the supply voltage to the adjustable frequency drive is lost and *14-10 Mains Failure* is NOT set to [0] *No Function*. Check the fuses to the adjustable frequency drive and line power supply to the unit.

ALARM 38, Internal fault

When an internal fault occurs, a code number defined in *Table 8.3* is displayed.

Troubleshooting

- Cycle power
- Check that the option is properly installed
- Check for loose or missing wiring

It may be necessary to contact your Danfoss supplier or service department. Note the code number for further troubleshooting directions.

No.	Text
0	Serial port cannot be initialized. Contact your Danfoss supplier or Danfoss Service Department.
256-258	Power EEPROM data is defective or too old. Replace power card.
512-519	Internal fault. Contact your Danfoss supplier or Danfoss Service Department.
783	Parameter value outside of min/max limits
1024-1284	Internal fault. Contact your Danfoss supplier or the Danfoss Service Department.
1299	Option SW in slot A is too old
1300	Option SW in slot B is too old
1302	Option SW in slot C1 is too old
1315	Option SW in slot A is not supported (not allowed)
1316	Option SW in slot B is not supported (not allowed)
1318	Option SW in slot C1 is not supported (not allowed)
1379-2819	Internal fault. Contact your Danfoss supplier or Danfoss Service Department.
2561	Replace control card
2820	LCP stack overflow
2821	Serial port overflow
2822	USB port overflow
3072-5122	Parameter value is outside its limits
5123	Option in slot A: Hardware incompatible with control board hardware
5124	Option in slot B: Hardware incompatible with control board hardware
5125	Option in slot C0: Hardware incompatible with control board hardware
5126	Option in slot C1: Hardware incompatible with control board hardware
5376-6231	Internal fault. Contact your Danfoss supplier or Danfoss Service Department.

Table 8.3 Internal Fault Codes

ALARM 39, Heatsink sensor

No feedback from the heatsink temperature sensor.

The signal from the IGBT thermal sensor is not available on the power card. The problem could be on the power card, on the gate drive card, or the ribbon cable between the power card and gate drive card.

WARNING 40, Overload of digital output terminal 27

Check the load connected to terminal 27 or remove short-circuit connection. Check *5-00 Digital I/O Mode* and *5-01 Terminal 27 Mode*.

WARNING 41, Overload of digital output terminal 29

Check the load connected to terminal 29 or remove short-circuit connection. Check *5-00 Digital I/O Mode* and *5-02 Terminal 29 Mode*.

WARNING 42, Overload of digital output on X30/6 or overload of digital output on X30/7

For X30/6, check the load connected to X30/6 or remove the short-circuit connection. Check *5-32 Term X30/6 Digi Out (MCB 101)*.

For X30/7, check the load connected to X30/7 or remove the short-circuit connection. Check *5-33 Term X30/7 Digi Out (MCB 101)*.

ALARM 45, Ground fault 2

Ground fault on start-up.

Troubleshooting

Check for proper grounding and loose connections.

Check for proper wire size.

Check motor cables for short-circuits or leakage currents.

ALARM 46, Power card supply

The supply on the power card is out of range.

There are three power supplies generated by the switch mode power supply (SMPS) on the power card: 24 V, 5 V, ± 18 V. When powered with 24 V DC with the MCB 107 option, only the 24 V and 5 V supplies are monitored. When powered with three phase AC line voltage, all three supplies are monitored.

Troubleshooting

Check for a defective power card.

Check for a defective control card.

Check for a defective option card.

If a 24 V DC power supply is used, verify proper supply power.

WARNING 47, 24 V supply low

The 24 V DC is measured on the control card. The external 24 V DC backup power supply may be overloaded, otherwise contact the Danfoss supplier.

WARNING 48, 1.8 V supply low

The 1.8 V DC supply used on the control card is outside of allowable limits. The power supply is measured on the control card. Check for a defective control card. If an option card is present, check for an overvoltage condition.

WARNING 49, Speed limit

When the speed is not within the specified range in *4-11 Motor Speed Low Limit [RPM]* and *4-13 Motor Speed High Limit [RPM]*, the adjustable frequency drive shows a warning. When the speed is below the specified limit in *1-86 Trip Speed Low [RPM]* (except when starting or stopping), the adjustable frequency drive will trip.

ALARM 50, AMA calibration failed

Contact your Danfoss supplier or Danfoss Service Department.

ALARM 51, AMA check U_{nom} and I_{nom}

The settings for motor voltage, motor current and motor power are wrong. Check the settings in parameters 1-20 to 1-25.

ALARM 52, AMA low I_{nom}

The motor current is too low. Check the settings.

ALARM 53, AMA motor too big

The motor is too big for the AMA to operate.

ALARM 54, AMA motor too small

The motor is too small for the AMA to operate.

ALARM 55, AMA parameter out of range

The parameter values of the motor are outside of the acceptable range. AMA will not run.

ALARM 56, AMA interrupted by user

The user has interrupted the AMA.

ALARM 57, AMA internal fault

Try to restart AMA again. Repeated restarts can overheat the motor.

ALARM 58, AMA Internal fault

Contact your Danfoss supplier.

WARNING 59, Current limit

The current is higher than the value in *4-18 Current Limit*. Ensure that motor data in parameters 1-20 to 1-25 are set correctly. Possibly increase the current limit. Be sure that the system can operate safely at a higher limit.

WARNING 60, External interlock

A digital input signal is indicating a fault condition external to the adjustable frequency drive. An external interlock has commanded the adjustable frequency drive to trip. Clear the external fault condition. To resume normal operation, apply 24 V DC to the terminal programmed for external interlock. Reset the adjustable frequency drive.

WARNING 62, Output frequency at maximum limit

The output frequency has reached the value set in *4-19 Max Output Frequency*. Check the application to determine the cause. Possibly increase the output frequency limit. Be sure the system can operate safely at a higher output frequency. The warning will clear when the output drops below the maximum limit.

WARNING/ALARM 65, Control card overtemperature

The cut-out temperature of the control card is 176 °F [80 °C].

Troubleshooting

- Check that the ambient operating temperature is within limits.
- Check for clogged filters.
- Check fan operation.
- Check the control card.

WARNING 66, Heatsink temperature low

The adjustable frequency drive is too cold to operate. This warning is based on the temperature sensor in the IGBT module.

Increase the ambient temperature of the unit. Also, a trickle amount of current can be supplied to the adjustable frequency drive whenever the motor is stopped by setting *2-00 DC Hold/Preheat Current* at 5% and *1-80 Function at Stop*.

ALARM 67, Option module configuration has changed

One or more options have either been added or removed since the last power-down. Check that the configuration change is intentional and reset the unit.

ALARM 68, Safe Stop activated

Loss of the 24 V DC signal on terminal 37 has caused the filter to trip. To resume normal operation, apply 24 V DC to terminal 37 and reset the filter.

ALARM 69, Power card temperature

The temperature sensor on the power card is either too hot or too cold.

Troubleshooting

- Check that the ambient operating temperature is within limits.
- Check for clogged filters.
- Check fan operation.
- Check the power card.

ALARM 70, Illegal FC configuration

The control card and power card are incompatible. Contact your supplier with the type code of the unit from the nameplate and the part numbers of the cards to check compatibility.

ALARM 78, Tracking error Drive initialized to default value

Parameter settings are initialized to default settings after a manual reset. Reset the unit to clear the alarm.

ALARM 92, No-Flow

A no-flow condition has been detected in the system. *22-23 No-Flow Function* is set for alarm. Troubleshoot the system and reset the adjustable frequency drive after the fault has been cleared.

ALARM 93, Dry pump

A no-flow condition in the system with the adjustable frequency drive operating at high speed may indicate a dry pump. *22-26 Dry Pump Function* is set for alarm. Troubleshoot the system and reset the adjustable frequency drive after the fault has been cleared.

ALARM 94, End of curve

Feedback is lower than the setpoint. This may indicate leakage in the system. *22-50 End of Curve Function* is set for alarm. Troubleshoot the system and reset the adjustable frequency drive after the fault has been cleared.

ALARM 95, Broken belt

Torque is below the torque level set for no load, indicating a broken belt. *22-60 Broken Belt Function* is set for alarm. Troubleshoot the system and reset the adjustable frequency drive after the fault has been cleared.

ALARM 96, Start delayed

Motor start has been delayed due to short-cycle protection. *22-76 Interval between Starts* is enabled. Troubleshoot the system and reset the adjustable frequency drive after the fault has been cleared.

WARNING 97, Stop delayed

Stopping the motor has been delayed due to short cycle protection. *22-76 Interval between Starts* is enabled. Troubleshoot the system and reset the adjustable frequency drive after the fault has been cleared.

WARNING 98, Clock fault

Time is not set or the RTC clock has failed. Reset the clock in *0-70 Date and Time*.

WARNING 203, Missing motor

With an adjustable frequency drive operating multi-motors, an underload condition was detected. This could indicate a missing motor. Inspect the system for proper operation.

WARNING 204, Locked rotor

With an adjustable frequency drive operating multi-motors, an overload condition was detected. This could indicate a locked rotor. Inspect the motor for proper operation.

WARNING 250, New spare part

A component in the adjustable frequency drive has been replaced. Reset the adjustable frequency drive for normal operation.

WARNING 251, New type code

The power card or other components have been replaced and the type code changed. Reset to remove the warning and resume normal operation.

9 Basic Troubleshooting

9.1 Start-up and Operation

Symptom	Possible Cause	Test	Solution
Display dark/No function	Missing input power	See <i>Table 3.1</i> .	Check the input power source.
	Missing or open fuses or circuit breaker tripped	See open fuses and tripped circuit breaker in this table for possible causes.	Follow the recommendations provided.
	No power to the LCP	Check the LCP cable for proper connection or damage.	Replace the faulty LCP or connection cable.
	Shortcut on control voltage (terminal 12 or 50) or at control terminals	Check the 24 V control voltage supply for terminal 12/13 to 20–39 or 10 V supply for terminal 50 to 55.	Wire the terminals properly.
	Wrong LCP (LCP from VLT® 2800 or 5000/6000/8000/ FCD or FCM)		Use only LCP 101 (P/N 130B1124) or LCP 102 (P/N 130B1107).
	Wrong contrast setting		Press [Status] + [▲]/[▼] to adjust the contrast.
	Display (LCP) is defective	Test using a different LCP.	Replace the faulty LCP or connection cable.
	Internal voltage supply fault or SMPS is defective		Contact supplier.
Intermittent display	Overloaded power supply (SMPS) due to improper control wiring or a fault within the adjustable frequency drive	To rule out a problem in the control wiring, disconnect all control wiring by removing the terminal blocks.	If the display stays lit, then the problem is in the control wiring. Check the wiring for shorts or incorrect connections. If the display continues to cut out, follow the procedure for display dark.

Symptom	Possible Cause	Test	Solution
Motor not running	Service switch open or missing motor connection	Check if the motor is connected and the connection is not interrupted (by a service switch or other device).	Connect the motor and check the service switch.
	No line power with 24 V DC option card	If the display is functioning but no output, check that line power is applied to the adjustable frequency drive.	Apply line power to run the unit.
	LCP Stop	Check if [Off] has been pressed.	Press [Auto On] or [Hand On] (depending on operation mode) to run the motor.
	Missing start signal (Standby)	Check 5-10 <i>Terminal 18 Digital Input</i> for correct setting for terminal 18 (use default setting).	Apply a valid start signal to start the motor.
	Motor coast signal active (Coasting)	Check 5-12 <i>Coast inv.</i> for correct setting for terminal 27 (use default setting).	Apply 24 V on terminal 27 or program this terminal to <i>No operation</i> .
	Wrong reference signal source	Check reference signal: Local, remote or bus reference? Preset reference active? Terminal connection correct? Scaling of terminals correct? Reference signal available?	Program correct settings. Check 3-13 <i>Reference Site</i> . Set preset reference active in parameter group 3-1* <i>References</i> . Check for correct wiring. Check scaling of terminals. Check reference signal.
Motor running in wrong direction	Motor rotation limit	Check that 4-10 <i>Motor Speed Direction</i> is programmed correctly.	Program correct settings.
	Active reversing signal	Check if a reversing command is programmed for the terminal in parameter group 5-1* <i>Digital inputs</i> .	Deactivate reversing signal.
	Wrong motor phase connection		See chapter 3.7 <i>Check Motor Rotation</i> in this manual.
Motor is not reaching maximum speed	Frequency limits set wrong	Check output limits in 4-13 <i>Motor Speed High Limit [RPM]</i> , 4-14 <i>Motor Speed High Limit [Hz]</i> and 4-19 <i>Max Output Frequency</i> .	Program correct limits.
	Reference input signal not scaled correctly	Check reference input signal scaling in 6-* <i>Analog I/O mode</i> and parameter group 3-1* <i>References</i> . Reference limits in parameter group 3-0* <i>Reference limits</i> .	Program correct settings.
Motor speed unstable	Possible incorrect parameter settings	Check the settings of all motor parameters, including all motor compensation settings. For closed-loop operation, check PID settings.	Check settings in parameter group 1-6* <i>Analog I/O mode</i> . For closed-loop operation, check settings in parameter group 20-0* <i>Feedback</i> .
Motor runs rough	Possible over-magnetization	Check for incorrect motor settings in all motor parameters.	Check motor settings in parameter groups 1-2* <i>Motor data</i> , 1-3* <i>Adv motor data</i> , and 1-5* <i>Load indep. setting</i> .
Motor will not brake.	Possible incorrect settings in the brake parameters. Possible too short ramp-down times.	Check brake parameters. Check ramp time settings.	Check parameter group 2-0* <i>DC brake</i> and 3-0* <i>Reference limits</i> .

Symptom	Possible Cause	Test	Solution
Open power fuses or circuit breaker trip.	Phase to phase short	Motor or panel has a short phase to phase. Check motor and panel phase for shorts.	Eliminate any shorts detected.
	Motor overload	Motor is overloaded for the application.	Perform start-up test and verify motor current is within specifications. If motor current is exceeding nameplate full load current, motor may run only with reduced load. Review the specifications for the application.
	Loose connections	Perform pre-start-up check for loose connections.	Tighten loose connections.
Line power current imbalance greater than 3%	Problem with line power (See <i>Alarm 4 Line phase loss</i> description)	Rotate input power leads into the adjustable frequency drive one position: A to B, B to C, C to A.	If imbalanced leg follows the wire, it is a power problem. Check line power supply.
	Problem with the adjustable frequency drive	Rotate input power leads into the adjustable frequency drive one position: A to B, B to C, C to A.	If imbalance leg stays on same input terminal, it is a problem with the unit. Contact the supplier.
Motor current imbalance greater than 3%	Problem with motor or motor wiring	Rotate output motor leads one position: U to V, V to W, W to U.	If imbalanced leg follows the wire, the problem is in the motor or motor wiring. Check motor and motor wiring.
	Problem with the adjustable frequency drives	Rotate output motor leads one position: U to V, V to W, W to U.	If imbalance leg stays on same output terminal, it is a problem with the unit. Contact the supplier.
Acoustic noise or vibration (e.g., a fan blade is making noise or vibrations at certain frequencies)	Resonances, e.g., in the motor/fan system	Bypass critical frequencies by using parameters in parameter group 4-6*.	Check if noise and/or vibration have been reduced to an acceptable limit.
		Turn off over-modulation in 14-03 <i>Overmodulation</i> .	
		Change switching pattern and frequency in parameter group 14-0*.	
		Increase Resonance Dampening in 1-64 <i>Resonance Dampening</i> .	

Table 9.1 Start-up and Operation

10 Specifications

10.1 Power-dependent Specifications

10.1.1 Line power supply 3x200–240 V AC

Adjustable frequency drive	P1K1	P1K5	P2K2	P3K0	P3K7
Typical Shaft Output [kW]	1.1	1.5	2.2	3	3.7
IP20/Chassis ⁶⁾	A2	A2	A2	A3	A3
IP55/Type 12	A4/A5	A4/A5	A4/A5	A5	A5
IP66/NEMA 4X	A4/A5	A4/A5	A4/A5	A5	A5
Typical Shaft Output [HP] at 208 V	1.5	2.0	2.9	4.0	4.9
Output current					
Continuous (3x200–240 V) [A]	6.6	7.5	10.6	12.5	16.7
Intermittent (3x200–240 V) [A]	7.3	8.3	11.7	13.8	18.4
Continuous kVA (208 V AC) [kVA]	2.38	2.70	3.82	4.50	6.00
Max. input current					
Continuous (3x200–240 V) [A]	5.9	6.8	9.5	11.3	15.0
Intermittent (3x200–240 V) [A]	6.5	7.5	10.5	12.4	16.5
Additional specifications					
Estimated power loss at rated max. load [W] ⁴⁾	63	82	116	155	185
IP20, IP21 max. cable cross-section (line power, motor, brake and load sharing) [mm ² /(AWG)]	4, 4, 4 (12, 12, 12) (min. 0.2 (24))				
IP55, IP66 max. cable cross-section (line power, motor, brake and load sharing) [mm ² /(AWG)]	4, 4, 4 (12, 12, 12)				
Max. cable cross-section with disconnect	6, 4, 4 (10, 12, 12)				
Weight enclosure IP20 (lb [kg])	10.8 [4.9]	10.8 [4.9]	10.8 [4.9]	14.55 [6.6]	14.55 [6.6]
Weight enclosure IP21 (lb [kg])	12.13 [5.5]	12.13 [5.5]	12.13 [5.5]	16.54 [7.5]	16.54 [7.5]
Weight enclosure IP55 (lbs [kg]) (A4/A5)	21.39/29.76 [9.7/13.5]	21.39/29.76 [9.7/13.5]	21.39/29.76 [9.7/13.5]	29.76 [13.5]	29.76 [13.5]
Weight enclosure IP66 (lbs [kg]) (A4/A5)	21.39/29.76 [9.7/13.5]	21.39/29.76 [9.7/13.5]	21.39/29.76 [9.7/13.5]	29.76 [13.5]	29.76 [13.5]
Efficiency ³⁾	0.96	0.96	0.96	0.96	0.96

Table 10.1 Line Power Supply 3x200–240 V AC - Normal overload 110% for 1 minute

Adjustable frequency drive	P5K5	P7K5	P11K	P15K	P18K	P22K	P30K	P37K	P45K
Typical Shaft Output [kW]	5.5	7.5	11	15	18.5	22	30	37	45
IP20/Chassis ⁷⁾	B3	B3	B3	B4	B4	C3	C3	C4	C4
IP21/NEMA 1	B1	B1	B1	B2	C1	C1	C1	C2	C2
IP55/Type 12	B1	B1	B1	B2	C1	C1	C1	C2	C2
IP66/NEMA 4X	B1	B1	B1	B2	C1	C1	C1	C2	C2
Typical Shaft Output [HP] at 208 V	7.5	10	15	20	25	30	40	50	60
Output current									
Continuous (3x200–240 V) [A]	24.2	30.8	46.2	59.4	74.8	88.0	115	143	170
Intermittent (3x200–240 V) [A]	26.6	33.9	50.8	65.3	82.3	96.8	127	157	187
Continuous kVA (208 V AC) [kVA]	8.7	11.1	16.6	21.4	26.9	31.7	41.4	51.5	61.2
Max. input current									
Continuous (3x200–240 V) [A]	22.0	28.0	42.0	54.0	68.0	80.0	104.0	130.0	154.0
Intermittent (3x200–240 V) [A]	24.2	30.8	46.2	59.4	74.8	88.0	114.0	143.0	169.0
Additional Specifications									
Estimated power loss at rated max. load [W] ⁴⁾	269	310	447	602	737	845	1140	1353	1636
IP20 max. cable cross-section (line power, brake, motor and load sharing)	10, 10 (8,8,-)		35,-,-(2,-,-)	35 (2)	50 (1)		300 MCM (150)		
IP21, IP55, IP66 max. cable cross- section (line power, motor) [mm ² /(AWG)]	10, 10 (8,8,-)		35, 25, 25 (2, 4, 4)	50 (1)			300 MCM (150)		
IP21, IP55, IP66 max. cable cross- section (brake, load sharing) [mm ² /(AWG)]	16, 10, 16 (6, 8, 6)		35,-,-(2,-,-)	50 (1)			95 (3/0)		
With line power disconnect switch included:	16/6			35/2	35/2			70/3/0	185/ kcmil350
Weight enclosure IP20 (lb [kg])	26.46 [12]	26.46 [12]	26.46 [12]	51.81 [23.5]	51.81 [23.5]	77.16 [35]	77.16 [35]	110.23 [50]	110.23 [50]
Weight enclosure IP21 (lb [kg])	50.71 [23]	50.71 [23]	50.71 [23]	59.53 [27]	99.21 [45]	99.21 [45]	99.21 [45]	143.3 [65]	143.3 [65]
Weight enclosure IP55 (lb [kg])	50.71 [23]	50.71 [23]	50.71 [23]	59.53 [27]	99.21 [45]	99.21 [45]	99.21 [45]	143.3 [65]	143.3 [65]
Weight enclosure IP66 (lb [kg])	50.71 [23]	50.71 [23]	50.71 [23]	59.53 [27]	99.21 [45]	99.21 [45]	99.21 [45]	143.3 [65]	143.3 [65]
Efficiency ³⁾	0.96	0.96	0.96	0.96	0.96	0.97	0.97	0.97	0.97

Table 10.2 Line Power Supply 3x200–240 V AC - Normal overload 110% for 1 minute

10.1.2 Line Power Supply 3 x 380–480 V AC

Adjustable frequency drive	P1K1	P1K5	P2K2	P3K0	P4K0	P5K5	P7K5
Typical Shaft Output [kW]	1.1	1.5	2.2	3	4	5.5	7.5
Typical Shaft Output [HP] at 460 V	1.5	2.0	2.9	4.0	5.0	7.5	10
IP20/Chassis ⁶⁾	A2	A2	A2	A2	A2	A3	A3
IP55/Type 12	A4/A5	A4/A5	A4/A5	A4/A5	A4/A5	A5	A5
IP66/NEMA 4X	A4/A5	A4/A5	A4/A5	A4/A5	A4/A5	A5	A5
Output current							
Continuous (3x380–440 V) [A]	3	4.1	5.6	7.2	10	13	16
Intermittent (3x380–440 V) [A]	3.3	4.5	6.2	7.9	11	14.3	17.6
Continuous (3x441–480 V) [A]	2.7	3.4	4.8	6.3	8.2	11	14.5
Intermittent (3x441–480 V) [A]	3.0	3.7	5.3	6.9	9.0	12.1	15.4
Continuous kVA (400 V AC) [kVA]	2.1	2.8	3.9	5.0	6.9	9.0	11.0
Continuous kVA (460 V AC) [kVA]	2.4	2.7	3.8	5.0	6.5	8.8	11.6
Max. input current							
Continuous (3x380–440 V) [A]	2.7	3.7	5.0	6.5	9.0	11.7	14.4
Intermittent (3x380–440 V) [A]	3.0	4.1	5.5	7.2	9.9	12.9	15.8
Continuous (3x441–480 V) [A]	2.7	3.1	4.3	5.7	7.4	9.9	13.0
Intermittent (3x441–480 V) [A]	3.0	3.4	4.7	6.3	8.1	10.9	14.3
Additional specifications							
Estimated power loss at rated max. load [W] ⁴⁾	58	62	88	116	124	187	255
IP20, IP21 max. cable cross-section (line power, motor, brake and load sharing) [[mm ² /(AWG)] ²⁾	4, 4, 4 (12, 12, 12) (min. 0.2 (24))						
IP55, IP66 max. cable cross-section (line power, motor, brake and load sharing) [[mm ² /(AWG)] ²⁾	4, 4, 4 (12, 12, 12)						
Max. cable cross-section with disconnect	6, 4, 4 (10, 12, 12)						
Weight enclosure IP20 (lb [kg])	10.58 [4.8]	10.8 [4.9]	10.8 [4.9]	10.8 [4.9]	10.8 [4.9]	14.55 [6.6]	14.55 [6.6]
Weight enclosure IP21 (lb [kg])							
Weight enclosure IP55 (lbs [kg]) (A4/A5)	21.39/29.76 [9.7/13.5]	21.39/29.76 [9.7/13.5]	21.39/29.76 [9.7/13.5]	21.39/29.76 [9.7/13.5]	21.39/29.76 [9.7/13.5]	31.31 [14.2]	31.31 [14.2]
Weight enclosure IP66 (lbs [kg]) (A4/A5)	21.39/29.76 [9.7/13.5]	21.39/29.76 [9.7/13.5]	21.39/29.76 [9.7/13.5]	21.39/29.76 [9.7/13.5]	21.39/29.76 [9.7/13.5]	31.31 [14.2]	31.31 [14.2]
Efficiency ³⁾	0.96	0.97	0.97	0.97	0.97	0.97	0.97

Table 10.3 Line Power Supply 3x380–480 V AC – Normal overload 110% for 1 minute

Adjustable frequency drive	P11K	P15K	P18K	P22K	P30K
Typical Shaft Output [kW]	11	15	18.5	22	30
Typical Shaft Output [HP] at 460 V	15	20	25	30	40
IP20/Chassis ⁷⁾	B3	B3	B3	B4	B4
IP21/NEMA 1	B1	B1	B1	B2	B2
IP55/Type 12	B1	B1	B1	B2	B2
IP66/NEMA 4X	B1	B1	B1	B2	B2
Output current					
Continuous (3x380–439 V) [A]	24	32	37.5	44	61
Intermittent (3x380–439 V) [A]	26.4	35.2	41.3	48.4	67.1
Continuous (3x440–480 V) [A]	21	27	34	40	52
Intermittent (3x440–480 V) [A]	23.1	29.7	37.4	44	61.6
Continuous kVA (400 V AC) [kVA]	16.6	22.2	26	30.5	42.3
Continuous kVA (460 V AC) [kVA]	16.7	21.5	27.1	31.9	41.4
Max. input current					
Continuous (3x380–439 V) [A]	22	29	34	40	55
Intermittent (3x380–439 V) [A]	24.2	31.9	37.4	44	60.5
Continuous (3x440–480 V) [A]	19	25	31	36	47
Intermittent (3x440–480 V) [A]	20.9	27.5	34.1	39.6	51.7
Additional specifications					
Estimated power loss at rated max. load [W] ⁴⁾	278	392	465	525	698
IP20 max. cable cross-section (line power, brake, motor and load sharing)	16, 10, - (8, 8, -)		35, -, - (2, -, -)		35 (2)
IP21, IP55, IP66 max. cable cross-section (line power, motor) [mm ² /(AWG)]	10, 10, 16 (6, 8, 6)		35, 25, 25 (2, 4, 4)		50 (1)
IP21, IP55, IP66 max. cable cross-section (brake, load sharing) [mm ² /(AWG)]	10, 10, - (8, 8, -)		35, -, - (2, -, -)		50 (1)
With line power disconnect switch included:	16/6				
Weight enclosure IP20 (lb [kg])	26.46 [12]	26.46 [12]	26.46 [12]	51.81 [23.5]	51.81 [23.5]
Weight enclosure IP21 (lb [kg])	50.71 [23]	50.71 [23]	50.71 [23]	59.53 [27]	59.53 [27]
Weight enclosure IP55 (lb [kg])	50.71 [23]	50.71 [23]	50.71 [23]	59.53 [27]	59.53 [27]
Weight enclosure IP66 (lb [kg])	50.71 [23]	50.71 [23]	50.71 [23]	59.53 [27]	59.53 [27]
Efficiency ³⁾	0.98	0.98	0.98	0.98	0.98

Table 10.4 Line Power Supply 3x380–480 V AC – Normal overload 110% for 1 minute

Adjustable frequency drive	P37K	P45K	P55K	P75K	P90K
Typical Shaft Output [kW]	37	45	55	75	90
Typical Shaft Output [HP] at 460 V	50	60	75	100	125
IP20/Chassis ⁷⁾	B4	C3	C3	C4	C4
IP21/NEMA 1	C1	C1	C1	C2	C2
IP55/Type 12	C1	C1	C1	C2	C2
IP66/NEMA 4X	C1	C1	C1	C2	C2
Output current					
Continuous (3x380–439 V) [A]	73	90	106	147	177
Intermittent (3x380–439 V) [A]	80.3	99	117	162	195
Continuous (3x440–480 V) [A]	65	80	105	130	160
Intermittent (3x440–480 V) [A]	71.5	88	116	143	176
Continuous kVA (400 V AC) [kVA]	50.6	62.4	73.4	102	123
Continuous kVA 460 V AC [kVA]	51.8	63.7	83.7	104	128
Max. input current					
Continuous (3x380–439 V) [A]	66	82	96	133	161
Intermittent (3x380–439 V) [A]	72.6	90.2	106	146	177
Continuous (3x440–480 V) [A]	59	73	95	118	145
Intermittent (3x440–480 V) [A]	64.9	80.3	105	130	160
Additional specifications					
Estimated power loss at rated max. load [W] ⁴⁾	739	843	1083	1384	1474
IP20 max. cable cross-section (line power, brake, motor and load sharing)	50 (1)		150 (300 MCM)		
IP21, IP55, IP66 max. cable cross-section (line power, motor) [mm ² /(AWG)]			150 (300 MCM)		
IP21, IP55, IP66 max. cable cross-section (brake, load sharing) [mm ² /(AWG)]			95 (3/0)		
With line power disconnect switch included:	35/2	35/2		70/3/0	185/kcmil350
Weight enclosure IP20 (lb [kg])	51.81 [23.5]	77.16 [35]	77.16 [35]	110.23 [50]	110.23 [50]
Weight enclosure IP21 (lb [kg])	99.21 [45]	99.21 [45]	99.21 [45]	143.3 [65]	143.3 [65]
Weight enclosure IP55 (lb [kg])	99.21 [45]	99.21 [45]	99.21 [45]	143.3 [65]	143.3 [65]
Weight enclosure IP66 (lb [kg])	99.21 [45]	99.21 [45]	99.21 [45]	143.3 [65]	143.3 [65]
Efficiency ³⁾	0.98	0.98	0.98	0.98	0.99

Table 10.5 Line Power Supply 3x380–480 V AC – Normal overload 110% for 1 minute

10.1.3 Line Power Supply 3x525–600 V AC

Adjustable frequency drive	P1K1	P1K5	P2K2	P3K0	P3K7	P4K0	P5K5	P7K5
Typical Shaft Output [kW]	1.1	1.5	2.2	3	3.7	4	5.5	7.5
IP20/Chassis	A3	A3	A3	A3	A2	A3	A3	A3
IP21/NEMA 1	A3	A3	A3	A3	A2	A3	A3	A3
IP55/Type 12	A5	A5	A5	A5	A5	A5	A5	A5
IP66/NEMA 4X	A5	A5	A5	A5	A5	A5	A5	A5
Output current								
Continuous (3x525–550 V) [A]	2.6	2.9	4.1	5.2	-	6.4	9.5	11.5
Intermittent (3x525–550 V) [A]	2.9	3.2	4.5	5.7	-	7.0	10.5	12.7
Continuous (3x525–600 V) [A]	2.4	2.7	3.9	4.9	-	6.1	9.0	11.0
Intermittent (3x525–600 V) [A]	2.6	3.0	4.3	5.4	-	6.7	9.9	12.1
Continuous kVA (525 V AC) [kVA]	2.5	2.8	3.9	5.0	-	6.1	9.0	11.0
Continuous kVA (575 V AC) [kVA]	2.4	2.7	3.9	4.9	-	6.1	9.0	11.0
Max. input current								
Continuous (3x525–600 V) [A]	2.4	2.7	4.1	5.2	-	5.8	8.6	10.4
Intermittent (3x525–600 V) [A]	2.7	3.0	4.5	5.7	-	6.4	9.5	11.5
Additional specifications								
Estim. power loss at rated max. load [W] 4)	50	65	92	122	-	145	195	261
IP20 max. cable cross-section (line power, motor, brake and load sharing) [mm ² /(AWG)]	4, 4, 4 (12, 12, 12) (min. 0.2 (24))							
IP55, IP 66 max. cable cross-section (line power, motor, brake and load sharing) [mm ² /(AWG)]	4, 4, 4 (12, 12, 12) (min. 0.2 (24))							
Max. cable cross-section with disconnect	6, 4, 4 (12, 12, 12)							
Line power disconnect switch included:	4/12							
Weight IP20 (lbs [kg])	14.33 [6.5]	14.33 [6.5]	14.33 [6.5]	14.33 [6.5]	-	14.33 [6.5]	14.55 [6.6]	14.55 [6.6]
Weight IP21/55 (lbs [kg])	29.76 [13.5]	29.76 [13.5]	29.76 [13.5]	29.76 [13.5]	29.76 [13.5]	29.76 [13.5]	31.31 [14.2]	31.31 [14.2]
Efficiency 4)	0.97	0.97	0.97	0.97	-	0.97	0.97	0.97

Table 10.6 Line Power Supply 3x525–600 V AC – Normal overload 110% for 1 minute

⁵⁾ With brake and load sharing 95/4/0

Adjustable frequency drive Typical Shaft Output [kW]	P11K 11	P15K 15	P18K 18.5	P22K 22	P30K 30	P37K 37	P45K 45	P55K 55	P75K 75	P90K 90
IP20/Chassis	B3	B3	B3	B4	B4	B4	C3	C3	C4	C4
IP21/NEMA 1	B1	B1	B1	B2	B2	C1	C1	C1	C2	C2
IP55/Type 12	B1	B1	B1	B2	B2	C1	C1	C1	C2	C2
IP66/NEMA 4X	B1	B1	B1	B2	B2	C1	C1	C1	C2	C2
Output current										
Continuous (3x525–550 V) [A]	19	23	28	36	43	54	65	87	105	137
Intermittent (3x525–550 V) [A]	21	25	31	40	47	59	72	96	116	151
Continuous (3x525–600 V) [A]	18	22	27	34	41	52	62	83	100	131
Intermittent (3x525–600 V) [A]	20	24	30	37	45	57	68	91	110	144
Continuous kVA (525 V AC) [kVA]	18.1	21.9	26.7	34.3	41	51.4	61.9	82.9	100	130.5
Continuous kVA (575 V AC) [kVA]	17.9	21.9	26.9	33.9	40.8	51.8	61.7	82.7	99.6	130.5
Max. input current										
Continuous (3x525–600 V) [A]	17.2	20.9	25.4	32.7	39	49	59	78.9	95.3	124.3
Intermittent (3x525–600 V) [A]	19	23	28	36	43	54	65	87	105	137
Additional specifications										
Estim. power loss at rated max. load [W] 4)	300	400	475	525	700	750	850	1100	1400	1500
IP21, IP55, IP66 max. cable cross-section (line power, brake and load sharing) [mm ² /(AWG)]	16, 10, 10 (6, 8, 8)		35,-,-(2,-,-)			50,-,- (1,-,-)		95 (4/0)		
IP21, IP55, IP66 max. cable cross-section (motor) [mm ² /(AWG)]	10, 10, - (8, 8, -)		35, 25, 25 (2, 4, 4)			50,-,- (1,-,-)		150 (300 MCM)		
IP20 max. cable cross-section (line power, brake and load sharing) [mm ² /(AWG)]	10, 10, - (8, 8, -)		35, -, - (2, -, -)			50,-,- (1,-,-)		150 (300 MCM)		
Max. cable cross-section with disconnect	16, 10, 10 (6, 8, 8)				50, 35, 35 (1, 2, 2)			95, 70, 70 (3/0, 2/0, 2/0)	185, 150, 120 (350 MCM, 300 MCM, 4/0)	
Line power disconnect switch included:	16/6					35/2			70/3/0	185/kcmil350
Weight IP20 (lbs [kg])	26.46 [12]	26.46 [12]	26.46 [12]	51.81 [23.5]	51.81 [23.5]	51.81 [23.5]	77.16 [35]	77.16 [35]	110.23 [50]	110.23 [50]
Weight IP21/IP55 (lbs [kg])	50.71 [23]	50.71 [23]	50.71 [23]	59.53 [27]	59.53 [27]	59.53 [27]	99.21 [45]	99.21 [45]	143.3 [65]	143.3 [65]
Efficiency ⁴⁾	0.98	0.98	0.98	0.98	0.98	0.98	0.98	0.98	0.98	0.98

Table 10.7 Line Power Supply 3x525–600 V AC – Normal overload 110% for 1 minute
⁵⁾ With brake and load sharing 95/4/0

10.1.4 Line Power Supply 3 x 525–690 V AC

Adjustable frequency drive	P11K	P15K	P18K	P22K	P30K	P37K	P45K	P55K	P75K	P90K
Typical Shaft Output [kW]	11	15	18.5	22	30	37	45	55	75	90
Typical Shaft Output [HP] at 575 V	10	16.4	20.1	24	33	40	50	60	75	100
IP21/NEMA 1	B2	B2	B2	B2	B2	C2	C2	C2	C2	C2
IP55/NEMA 12	B2	B2	B2	B2	B2	C2	C2	C2	C2	C2
Output current										
Continuous (3x525–550 V) [A]	14	19	23	28	36	43	54	65	87	105
Intermittent (3x525–550 V) [A]	15.4	20.9	25.3	30.8	39.6	47.3	59.4	71.5	95.7	115.5
Continuous (3x551–690 V) [A]	13	18	22	27	34	41	52	62	83	100
Intermittent (3x551–690 V) [A]	14.3	19.8	24.2	29.7	37.4	45.1	57.2	68.2	91.3	110
Continuous kVA (550 V AC) [kVA]	13.3	18.1	21.9	26.7	34.3	41	51.4	61.9	82.9	100
Continuous kVA (575 V AC) [kVA]	12.9	17.9	21.9	26.9	33.8	40.8	51.8	61.7	82.7	99.6
Continuous kVA (690 V AC) [kVA]	15.5	21.5	26.3	32.3	40.6	49	62.1	74.1	99.2	119.5
Max. cable size (line power, motor, brake) [mm ²]/(AWG) ²⁾	35 (1/0)					95 (4/0)				
Max. input current										
Continuous (3x525–690 V) [A]	15	19.5	24	29	36	49	59	71	87	99
Intermittent (3x525–690 V) [A]	16.5	21.5	26.4	31.9	39.6	53.9	64.9	78.1	95.7	108.9
Max. pre-fuses ¹⁾ [A]	63	63	63	63	80	100	125	160	160	160
Environment:										
Estimated power loss at rated max. load [W] ⁴⁾	201	285	335	375	430	592	720	880	1200	1440
Weight:										
IP21 (lbs [kg])	59.53 [27]	59.53 [27]	59.53 [27]	59.53 [27]	59.53 [27]	143.3 [65]	143.3 [65]	143.3 [65]	143.3 [65]	143.3 [65]
IP55 (lb [kg])	59.53 [27]	59.53 [27]	59.53 [27]	59.53 [27]	59.53 [27]	143.3 [65]	143.3 [65]	143.3 [65]	143.3 [65]	143.3 [65]
Efficiency ⁴⁾	0.98	0.98	0.98	0.98	0.98	0.98	0.98	0.98	0.98	0.98

¹⁾ For type of fuse, see *chapter 10.3 Fuse Specifications*

²⁾ American Wire Gauge

³⁾ Measured using 16 ft [5 m] shielded motor cables at rated load and rated frequency

⁴⁾ The typical power loss is at normal load conditions and expected to be within $\pm 15\%$ (tolerance relates to variety in voltage and cable conditions).

Values are based on a typical motor efficiency. Lower efficiency motors will also add to the power loss in the adjustable frequency drive and vice versa.

If the switching frequency is raised from nominal, the power losses may rise significantly.

LCP and typical control card power consumption values are included. Further options and customer load may add up to 30 W to the losses. (Though typically only 4 W extra for a fully loaded control card or options for slot A or slot B, each.)

Although measurements are made with state of the art equipment, some measurement inaccuracy must be allowed for ($\pm 5\%$).

⁵⁾ Motor and line cable: 300 MCM/150 mm²

⁶⁾ A2+A3 may be converted to IP21 using a conversion kit. See also *Mechanical mounting* and *IP21/Type 1 Enclosure kit* in the Design Guide.

⁷⁾ B3+4 and C3+4 may be converted to IP21 using a conversion kit. See also *Mechanical mounting* and *IP21/Type 1 Enclosure kit* in the Design Guide.

Table 10.8 Line Power Supply 3x525–690 V AC – Normal overload 110% for 1 minute

10.2 General Technical Data

Line power supply

Supply Terminals	L1, L2, L3
Supply voltage	200–240 V ±10%
Supply voltage	380–480 V ±10%
Supply voltage	525–600 V ±10%

AC line voltage low/line drop-out:

During low AC line voltage or a line drop-out, the adjustable frequency drive continues until the intermediate circuit voltage drops below the minimum stop level, which corresponds typically to 15% below the adjustable frequency drive's lowest rated supply voltage. Power-up and full torque cannot be expected at AC line voltage lower than 10% below the adjustable frequency drive's lowest rated supply voltage.

Supply frequency	50/60 Hz ±5%
Max. temporary imbalance between line phases	3.0% of rated supply voltage
True Power Factor (λ)	≥ 0.9 nominal at rated load
Displacement Power Factor ($\cos \phi$)	Near unity (> 0.98)
Switching on input supply L1, L2, L3 (power-ups) ≤7.5 kW	Maximum 2 times/min.
Switching on input supply L1, L2, L3 (power-ups) 11–75 kW	Maximum 1 time/min.
Switching on input supply L1, L2, L3 (power-ups) ≥ 90 kW	Maximum 1 time/2 min.
Environment according to EN60664-1	Overvoltage category III/pollution degree 2

The unit is suitable for use on a circuit capable of delivering not more than 100,000 RMS symmetrical Amperes, 240/500/600/690 V maximum.

Motor output (U, V, W)

Output voltage	0–100% of supply voltage
Output frequency (1.1–90 kW)	0–590 Hz
Switching on output	Unlimited
Ramp times	1–3600 s

¹⁾ Voltage and power dependent

Torque characteristics

Starting torque (Constant torque)	Maximum 110% for 1 min.*
Starting torque	Maximum 135% up to 0.5 s*
Overload torque (Constant torque)	Maximum 110% for 1 min.*

*Percentage relates to FC 103's nominal torque.

Cable lengths and cross-sections for control cables¹⁾

Max. motor cable length, shielded	500 ft [150 m]
Max. motor cable length, non-shielded	1,000 ft [300 m]
Maximum cross-section to control terminals, flexible/ rigid wire without cable end sleeves	0.0023 in ² [1.5 mm ²]/16 AWG
Maximum cross-section to control terminals, flexible wire with cable end sleeves	0.0016 in ² [1 mm ²]/18 AWG
Maximum cross-section to control terminals, flexible wire with cable end sleeves with collar	0.0008 in ² [0.5 mm ²]/20 AWG
Minimum cross-section to control terminals	0.25 mm ² /24 AWG

¹⁾For power cables, see electrical data tables.

Digital inputs

Programmable digital inputs	4 (6) ¹⁾
Terminal number	18, 19, 27 ¹⁾ , 29 ¹⁾ , 32, 33,
Logic	PNP or NPN
Voltage level	0–24 V DC
Voltage level, logic '0' PNP	<5 V DC
Voltage level, logic '1' PNP	>10 V DC
Voltage level, logic '0' NPN ²⁾	>19 V DC
Voltage level, logic '1' NPN ²⁾	<14 V DC
Maximum voltage on input	28 V DC
Pulse frequency ranges	0–110 kHz
(Duty cycle) Min. pulse width	4.5 ms
Input resistance, R _i	Approx. 4 kΩ

Safe Torque Off Terminal 37^{3, 4)} (Terminal 37 is fixed PNP logic)

Voltage level	0–24 V DC
Voltage level, logic '0' PNP	<4 V DC
Voltage level, logic '1' PNP	>20 V DC
Maximum voltage on input	28 V DC
Typical input current at 24 V	50 mA rms
Typical input current at 20 V	60 mA rms
Input capacitance	400 nF

All digital inputs are galvanically isolated from the supply voltage (PELV) and other high-voltage terminals.

¹⁾ Terminals 27 and 29 can also be programmed as output.

²⁾ Except Safe Torque Off input Terminal 37.

³⁾ See chapter 2.4.6.6 Terminal 37 for further information about terminal 37 and Safe Torque Off.

⁴⁾ When using a contactor with a DC coil inside in combination with Safe Torque Off, it is important to make a return way for the current from the coil when turning it off. This can be done by using a freewheel diode (or, alternatively, a 30 or 50 V MOV for quicker response time) across the coil. Typical contactors can be bought with this diode.

Analog inputs

Number of analog inputs	2
Terminal number	53, 54
Modes	Voltage or current
Mode select	Switch S201 and switch S202
Voltage mode	Switch S201/switch S202 = OFF (U)
Voltage level	-10 to +10 V (scaleable)
Input resistance, R _i	Approx. 10 kΩ
Max. voltage	±20 V
Current mode	Switch S201/switch S202 = ON (I)
Current level	0/4 to 20 mA (scaleable)
Input resistance, R _i	Approx. 200 Ω
Max. current	30 mA
Resolution for analog inputs	10 bit (+ sign)
Accuracy of analog inputs	Max. error 0.5% of full scale
Bandwidth	100 Hz

The analog inputs are galvanically isolated from the supply voltage (PELV) and other high-voltage terminals.

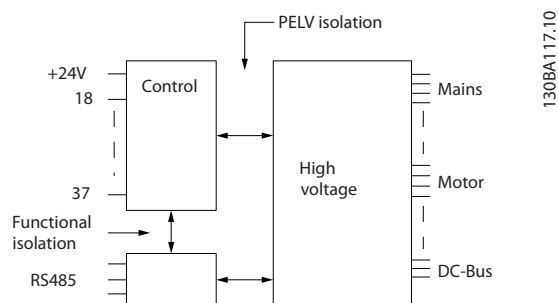

Figure 10.1 PELV Isolation of Analog Inputs

Pulse inputs

Programmable pulse	2/1
Terminal number pulse	29, 33 ¹⁾ /32 ²⁾ , 33 ²⁾
Max. frequency at terminal 29, 32, 33	110 kHz (push-pull driven)
Max. frequency at terminal 29, 32, 33	5 kHz (open collector)
Min. frequency at terminal 29, 32, 33	4 Hz
Voltage level	See chapter 10.2.1 Digital Inputs
Maximum voltage on input	28 V DC
Input resistance, R _i	Approx. 4 kΩ
Pulse input accuracy (0.1–1 kHz)	Max. error: 0.1% of full scale
Encoder input accuracy (1–11 kHz)	Max. error: 0.05% of full scale

The pulse and encoder inputs (terminals 29, 32, 33) are galvanically isolated from the supply voltage (PELV) and other high-voltage terminals.

- 1) Pulse inputs are 29 and 33
- 2) Encoder inputs: 32 = A, and 33 = B

Analog output

Number of programmable analog outputs	1
Terminal number	42
Current range at analog output	0/4–20 mA
Max. load GND - analog output	500 Ω
Accuracy on analog output	Max. error: 0.5% of full scale
Resolution on analog output	12 bit

The analog output is galvanically isolated from the supply voltage (PELV) and other high-voltage terminals.

Control card, RS-485 serial communication

Terminal number	68 (P,TX+, RX+), 69 (N,TX-, RX-)
Terminal number 61	Common for terminals 68 and 69

The RS-485 serial communication circuit is functionally separated from other central circuits and galvanically isolated from the supply voltage (PELV).

Digital output

Programmable digital/pulse outputs	2
Terminal number	27, 29 ¹⁾
Voltage level at digital/frequency output	0–24 V
Max. output current (sink or source)	40 mA
Max. load at frequency output	1 k Ω
Max. capacitive load at frequency output	10 nF
Minimum output frequency at frequency output	0 Hz
Maximum output frequency at frequency output	32 kHz
Accuracy of frequency output	Max. error: 0.1% of full scale
Resolution of frequency outputs	12 bit

¹⁾ Terminal 27 and 29 can also be programmed as input.

The digital output is galvanically isolated from the supply voltage (PELV) and other high-voltage terminals.

Control card, 24 V DC output

Terminal number	12, 13
Output voltage	24 V +1, -3 V
Max. load	200 mA

The 24 V DC supply is galvanically isolated from the supply voltage (PELV), but has the same potential as the analog and digital inputs and outputs.

Relay outputs

Programmable relay outputs	
Relay 01 Terminal number	1-3 (break), 1-2 (make)
Max. terminal load (AC-1) ¹⁾ on 1-3 (NC), 1-2 (NO) (Resistive load)	240 V AC, 2 A
Max. terminal load (AC-15) ¹⁾ (Inductive load @ cos ϕ 0.4)	240 V AC, 0.2 A
Max. terminal load (DC-1) ¹⁾ on 1-2 (NO), 1-3 (NC) (Resistive load)	60 V DC, 1 A
Max. terminal load (DC-13) ¹⁾ (Inductive load)	24 V DC, 0.1 A
Relay 02 Terminal number	4-6 (break), 4-5 (make)
Max. terminal load (AC-1) ¹⁾ on 4-5 (NO) (Resistive load) ²⁾³⁾ Overvoltage cat. II	400 V AC, 2 A
Max. terminal load (AC-15) ¹⁾ on 4-5 (NO) (Inductive load @ cos ϕ 0.4)	240 V AC, 0.2 A
Max. terminal load (DC-1) ¹⁾ on 4-5 (NO) (resistive load)	80 V DC, 2 A
Max. terminal load (DC-13) ¹⁾ on 4-5 (NO) (inductive load)	24 V DC, 0.1 A
Max. terminal load (AC-1) ¹⁾ on 4-6 (NC) (resistive load)	240 V AC, 2 A
Max. terminal load (AC-15) ¹⁾ on 4-6 (NC) (Inductive load @ cos ϕ 0.4)	240 V AC, 0.2 A
Max. terminal load (DC-1) ¹⁾ on 4-6 (NC) (resistive load)	50 V DC, 2 A
Max. terminal load (DC-13) ¹⁾ on 4-6 (NC) (inductive load)	24 V DC, 0.1 A
Min. terminal load on 1-3 (NC), 1-2 (NO), 4-6 (NC), 4-5 (NO)	24 V DC 10 mA, 24 V AC 20 mA
Environment according to EN 60664-1	Overvoltage category III/pollution degree 2

¹⁾ IEC 60947 part 4 and 5

The relay contacts are galvanically isolated from the rest of the circuit by reinforced isolation (PELV).

²⁾ Overvoltage Category II

³⁾ UL applications 300 V AC 2A

Control card, 10 V DC output

Terminal number	50
Output voltage	10.5 V \pm 0.5 V
Max. load	15 mA

The 10 V DC supply is galvanically isolated from the supply voltage (PELV) and other high-voltage terminals.

Control characteristics

Resolution of output frequency at 0–590 Hz	± 0.003 Hz
Repeat accuracy of <i>Precise start/stop</i> (terminals 18, 19)	≤± 0.1 ms
System response time (terminals 18, 19, 27, 29, 32, 33)	≤ 2 ms
Speed control range (open-loop)	1:100 of synchronous speed
Speed control range (closed-loop)	1:1000 of synchronous speed
Speed accuracy (open-loop)	30–4000 rpm: error ±8 rpm
Speed accuracy (closed-loop), depending on resolution of feedback device	0–6000 rpm: error ±0.15 rpm

All control characteristics are based on a 4-pole asynchronous motor.

Environment

Enclosure	IP20 ¹⁾ /Type 1, IP21 ²⁾ /Type 1, IP55/Type 12, IP66
Vibration test	1.0 g
Max. relative humidity	5–93% (IEC 721-3-3; Class 3K3 (non-condensing) during operation)
Aggressive environment (IEC 60068-2-43) H ₂ S test	Class Kd
Ambient temperature ³⁾	Max. 122 °F [50 °C] (24-hour average maximum 113 °F [45 °C])

¹⁾ Only for ≤ 3.7 kW (200–240 V), ≤ 7.5 kW (380–480 V)

²⁾ As enclosure kit for ≤ 3.7 kW (200–240 V), ≤ 7.5 kW (380–480 V)

³⁾ Derating for high ambient temperature, see special conditions in the Design Guide

Minimum ambient temperature during full-scale operation	32 °F [0 °C]
Minimum ambient temperature at reduced performance	14 °F [-10 °C]
Temperature during storage/transport	-13–+149/158 °F [-25–+65/70 °C]
Maximum altitude above sea level without derating	3,280 ft [1,000 m]

Derating for high altitude, see special conditions in the Design Guide.

EMC standards, Emission	EN 61800-3, EN 61000-6-3/4, EN 55011
EMC standards, Immunity	EN 61800-3, EN 61000-6-1/2, EN 61000-4-2, EN 61000-4-3, EN 61000-4-4, EN 61000-4-5, EN 61000-4-6

See section on special conditions in the Design Guide.

Control card performance

Scan interval	1 ms
---------------	------

Control card, USB serial communication

USB standard	1.1 (Full speed)
USB plug	USB type B "device" plug

Connection to PC is carried out via a standard host/device USB cable.

The USB connection is galvanically isolated from the supply voltage (PELV) and other high-voltage terminals.

The USB ground connection is not galvanically isolated from protection ground. Use only an isolated laptop as PC connection to the USB connector on the adjustable frequency drive.

Protection and Features

- Electronic thermal motor protection against overload.
- Temperature monitoring of the heatsink ensures that the adjustable frequency drive trips if the temperature reaches a predefined level. An overload temperature cannot be reset until the temperature of the heatsink is below the values stated in the tables on the following pages (guideline - these temperatures may vary for different power sizes, frame sizes, enclosure ratings, etc.).
- The adjustable frequency drive is protected against short-circuits on motor terminals U, V, W.
- If a line phase is missing, the adjustable frequency drive trips or issues a warning (depending on the load).
- Monitoring of the intermediate circuit voltage ensures that the adjustable frequency drive trips if the intermediate circuit voltage is too low or too high.
- The adjustable frequency drive constantly checks for critical levels of internal temperature, load current, high voltage on the intermediate circuit and low motor speeds. As a response to a critical level, the adjustable frequency drive can adjust the switching frequency and/or change the switching pattern in order to ensure the performance of the adjustable frequency drive.

10.3 Fuse Specifications

10.3.1 Branch Circuit Protection Fuses

For compliance with IEC/EN 61800-5-1 electrical standards, the following fuses are recommended.

Adjustable frequency drive	Maximum fuse size	Voltage	Type
200–240 V - T2			
1K1-1K5	16A ¹	200–240	type gG
2K2	25A ¹	200–240	type gG
3K0	25A ¹	200–240	type gG
3K7	35A ¹	200–240	type gG
5K5	50A ¹	200–240	type gG
7K5	63A ¹	200–240	type gG
11K	63A ¹	200–240	type gG
15K	80A ¹	200–240	type gG
18K5	125A ¹	200–240	type gG
22K	125A ¹	200–240	type gG
30K	160A ¹	200–240	type gG
37K	200A ¹	200–240	type aR
45K	250A ¹	200–240	type aR
380–480 V - T4			
1K1-1K5	10A ¹	380–500	type gG
2K2-3K0	16A ¹	380–500	type gG
4K0-5K5	25A ¹	380–500	type gG
7K5	35A ¹	380–500	type gG
11K-15K	63A ¹	380–500	type gG
18K	63A ¹	380–500	type gG
22K	63A ¹	380–500	type gG
30K	80A ¹	380–500	type gG
37K	100A ¹	380–500	type gG
45K	125A ¹	380–500	type gG
55K	160A ¹	380–500	type gG
75K	250A ¹	380–500	type aR
90K	250A ¹	380–500	type aR
1) Max. fuses - see national/international regulations for selecting an applicable fuse size.			

Table 10.9 EN50178 fuses 200 V to 480 V

Enclosure size	Power (hp [kW])	Recommended fuse size	Recommended max. fuse	Recommended circuit breaker Danfoss	Max. trip level [A]
A3	1.5 [1.1]	gG-6	gG-25	CTI25M 10-16	16
	2 [1.5]	gG-6	gG-25	CTI25M 10-16	16
	3 [2.2]	gG-6	gG-25	CTI25M 10-16	16
	4 [3]	gG-10	gG-25	CTI25M 10-16	16
	5 [4]	gG-10	gG-25	CTI25M 10-16	16
	7.5 [5.5]	gG-16	gG-25	CTI25M 10-16	16
	10 [7.5]	gG-16	gG-25	CTI25M 10-16	16
B2	15 [11]	gG-25	gG-63		
	20 [15]	gG-25	gG-63		
	25 [18]	gG-32			
	30 [22]	gG-32			
C2	40 [30]	gG-40			
	50 [37]	gG-63	gG-80		
	60 [45]	gG-63	gG-100		
	75 [55]	gG-80	gG-125		
	100 [75]	gG-100	gG-160		
C3	50 [37]	gG-100	gG-125		
	60 [45]	gG-125	gG-160		
D	50 [37]	gG-125	gG-125		
	60 [45]	gG-160	gG-160		
	75–100 [55–75]	gG-200	gG-200		
	125 [90]	aR-250	aR-250		
	150 [110]	aR-315	aR-315		
	175–250 [132–160]	aR-350	aR-350		
	300 [200]	aR-400	aR-400		
	350 [250]	aR-500	aR-500		
	450 [315]	aR-550	aR-550		
E	475–550 [355–400]	aR-700	aR-700		
	650–750 [500–560]	aR-900	aR-900		
F	850–1200 [630–900]	aR-1600	aR-1600		
	1350 [1000]	aR-2000	aR-2000		
	1600 [1200]	aR-2500	aR-2500		

Table 10.10 525–690 V, Frame Sizes A, C, D, E and F (non-UL fuses)

10.3.2 Substitute Fuses for 240 V

Original fuse	Manufacturer	Substitute fuses
KTN	Bussmann	KTS
FWX	Bussmann	FWH
KLNR	LITTEL FUSE	KLSR
L50S	LITTEL FUSE	L50S
A2KR	FERRAZ SHAWMUT	A6KR
A25X	FERRAZ SHAWMUT	A50X

Table 10.11 Substitute Fuses

10.4 Connection Tightening Torques

Enclosure	Power (hp [kW])			Torque [Nm]						
	200–240 V	380–480/ 500 V	525–600 V	525–690 V	Line power	Motor	DC connection	Brake	Ground	Relay
A2	1.5–3 [1.1–2.2]	1.5–5 [1.1–4.0]			1.8	1.8	1.8	1.8	3	0.6
A3	4–5 [3.0–3.7]	7.5–10 [5.5–7.5]	1.5–10 [1.1–7.5]		1.8	1.8	1.8	1.8	3	0.6
A4	1.5–3 [1.1–2.2]	1.5–5 [1.1–4.0]			1.8	1.8	1.8	1.8	3	0.6
A5	1.5–5 [1.1–3.7]	1.5–10 [1.1–7.5]	1.5–10 [1.1–7.5]		1.8	1.8	1.8	1.8	3	0.6
B1	7.5–10 [5.5–7.5]	15–20 [11–15]	15–20 [11–15]		1.8	1.8	1.5	1.5	3	0.6
B2	15 [11]	25 [18] 30 [22]	25 [18] 30 [22]	15 [11] 30 [22]	4.5 4.5	4.5 4.5	3.7 3.7	3.7 3.7	3 3	0.6 0.6
B3	7.5–10 [5.5–7.5]	15–20 [11–15]	15–20 [11–15]		1.8	1.8	1.8	1.8	3	0.6
B4	15–20 [11–15]	25–40 [18–30]	25–40 [18–30]		4.5	4.5	4.5	4.5	3	0.6
C1	20–30 [15–22]	40–60 [30–45]	40–60 [30–45]		10	10	10	10	3	0.6
C2	40–50 [30–37]	75–100 [55–75]	75–100 [55–75]	40–100 [30–75]	14/24 ¹⁾	14/24 ¹⁾	14	14	3	0.6
C3	25–30 [18–22]	50–60 [37–45]	50–60 [37–45]		10	10	10	10	3	0.6
C4	40–50 [30–37]	75–100 [55–75]	75–100 [55–75]		14/24 ¹⁾	14/24 ¹⁾	14	14	3	0.6

Table 10.12 Tightening of Terminals

¹⁾ For different cable dimensions x/y, where $x \leq 95 \text{ mm}^2$ and $y \geq 95 \text{ mm}^2$.

10

Index

A

A53..... 25

A54..... 25

AC input..... 7, 19

AC Line Input Connection for A2 and A3..... 20

AC Line Input Connection for A4 and A5..... 21

AC Line Input Connection for B1 and B2..... 22

AC Line Input Connection for C1 and C2..... 22

AC line power..... 6, 7, 10

AC Line Power..... 19

AC line voltage..... 43, 44, 61

AC waveform..... 6, 7

Accel time..... 40

Adjustable frequency drive..... 23

Adjustable Frequency Drive Block Diagram..... 6

Alarm Log..... 43

Alarm/Warning Code List..... 65

Alarms..... 63

AMA..... 67, 70

Analog input..... 66

Analog inputs..... 23

Analog output..... 23

Analog signal..... 66

Approvals..... iii

Auto..... 44

Auto mode..... 43

Auto On..... 44, 60, 62

Automatic motor adaptation..... 38, 60

Auto-reset..... 42

B

Backplate..... 9

Braking..... 60, 68

C

Circuit breakers..... 31

Clearance..... 9

Clearance requirements..... 8

Closed-loop..... 25

Communication option..... 69

Conduit..... 13, 17, 31

Control cables..... 25

Control card..... 66

Control card, USB serial communication..... 89

Control signal..... 47, 48, 60

Control system..... 6

Control terminals..... 10, 24, 37, 44, 49, 60, 62

Control wire..... 24

Control wiring..... 13, 14, 24, 31

Cooling..... 8

Cooling clearance..... 31

Copying Parameter Settings..... 45

Current limit..... 40

Current rating..... 8, 67

D

DC current..... 7, 61

DC link..... 66

Derating..... 8

Digital input..... 25, 62, 67

Digital inputs..... 23, 62

Digital Inputs..... 49

Disconnect switch..... 32

Disconnect switches..... 30

Downloading Data from the LCP..... 45

E

Electrical noise..... 14

EMC..... 31

EN50178 fuses 200 V to 480 V..... 91

External commands..... 7, 62

External controllers..... 6

External interlock..... 25, 49

External voltage..... 48

F

Fault log..... 43

Feedback..... 25, 31, 61, 70, 71

Five Ways of Operating..... 46

Floating delta..... 19

Full load current..... 8, 30

Functional testing..... 6, 40

Fuses..... 31, 69, 73, 91

Fusing..... 13, 31

G

Ground connections.....	14, 31
Ground loops.....	25
Ground wire.....	14, 31
Grounded delta.....	19
Grounding.....	14, 16, 19, 30, 31
Grounding Using Shielded Cable.....	15

H

Hand.....	40, 44
Hand On.....	40, 44
Harmonics.....	7
How to connect to line power and grounding for B1 and B2	22

I

IEC 61800-3.....	19
Induced voltage.....	13
Initialization.....	46
Input current.....	19
Input disconnect.....	19
Input power.....	7, 13, 14, 19, 30, 31, 63, 73
Input signal.....	48
Input signals.....	25
Input terminal.....	66
Input terminals.....	10, 19, 25, 30
Input voltage.....	32, 63
Installation.....	6, 8, 9, 13, 24, 31, 32
Isolated line power.....	19

L

Leakage current.....	30
Lifting.....	9
Line power.....	13
Local control.....	42, 44, 60
Local control panel.....	42
Local Control Test.....	40
Local mode.....	40
Local operation.....	42
Local start.....	40

M

Main menu.....	47
----------------	----

Main Menu.....	43
Manual Initialization.....	46
Menu keys.....	42, 43
Menu Keys.....	43
Menu structure.....	44
Menu Structure.....	51
Motor cables.....	8, 13, 16, 40
Motor current.....	7, 38, 43, 70
Motor data.....	38, 40, 67, 70
Motor Data.....	38
Motor frequency.....	43
Motor output.....	85
Motor power.....	10, 13, 14, 43, 70
Motor protection.....	13, 90
Motor rotation.....	40, 43
Motor speeds.....	37
Motor status.....	6
Motor wiring.....	13, 15, 31
Mounting.....	9, 31
Multiple adjustable frequency drives.....	13, 16
Multiple motors.....	30

N

Navigation keys.....	37, 42, 44, 47, 60
Navigation Keys.....	44
Noise isolation.....	13, 31

O

Open-loop.....	25, 47
Operation keys.....	44
Operation Keys.....	44
Optional equipment.....	16, 25, 32
Output current.....	61, 66
Output signal.....	50
Output terminals.....	10, 30
Overcurrent.....	61
Overload protection.....	8, 13
Overvoltage.....	40, 61

P

Parameter Settings.....	45
Phase loss.....	66
Power connections.....	14
Power factor.....	7, 16, 31

Power-dependent.....	76	System Monitoring.....	63
Pre-start.....	30	System Start-up.....	41
Programming.....	6, 25, 40, 42, 43, 45, 46, 50, 66		
Q			
Quick menu.....	43, 47, 50		
Quick Menu.....	43		
R			
Ramp-down time.....	40		
Ramp-up time.....	40		
RCD.....	15		
Reference.....	iii, 43, 57, 60, 61, 62		
Relay outputs.....	23		
Remote commands.....	6		
Remote programming.....	46		
Remote reference.....	61		
Reset.....	42, 44, 46, 62, 63, 66, 71		
Restoring Default Settings.....	45		
RFI filter.....	19		
RMS current.....	7		
RS-485.....	29		
Run command.....	41		
Run permissive.....	61		
S			
Safety Inspection.....	30		
Serial communication.....	6, 10, 23, 24, 44, 60, 61, 62, 63		
Setpoint.....	62		
Set-up.....	41, 43		
Shielded cable.....	8, 13, 31		
Shielded wire.....	13		
Short circuit.....	68		
Sleep Mode.....	62		
Specifications.....	6, 10, 76		
Speed reference.....	25, 41, 48, 60		
Start-up.....	6, 46, 47		
Status mode.....	60		
Stop command.....	61		
Supply voltage.....	23, 30, 69		
Switching frequency.....	61		
Symbols.....	iii		
System feedback.....	6		
		T	
		T6 Line Power Supply 3x525–600 V AC.....	81
		Temperature limits.....	31
		Terminal 53.....	25, 47, 48
		Terminal 54.....	25
		Terminal Programming Examples.....	49
		Tightening of Terminals.....	93
		Torque characteristics.....	85
		Torque limit.....	40
		Transient protection.....	7
		Trip.....	63
		Trip function.....	13
		Trip lock.....	63
		Troubleshooting.....	6
		U	
		Uploading Data to the LCP.....	45
		V	
		Voltage imbalance.....	66
		Voltage level.....	86
		W	
		Warning and Alarm Definitions.....	64
		Warning and Alarm Displays.....	63
		Warning and Alarm Types.....	63
		Wire sizes.....	14, 16



www.danfoss.com/drives

.....
Danfoss shall not be responsible for any errors in catalogs, brochures or other printed material. Danfoss reserves the right to alter its products at any time without notice, provided that alterations to products already on order shall not require material changes in specifications previously agreed upon by Danfoss and the Purchaser. All trademarks in this material are property of the respective companies. Danfoss and the Danfoss logotype are trademarks of Danfoss A/S. All rights reserved.
.....

