



Instruction Manual

VLT[®] Refrigeration Drive FC 103

1.1–90 kW



Contents

1 Introduction	4
1.1 Purpose of the Manual	4
1.2 Additional Resources	4
1.3 Document and Software Version	4
1.4 Product Overview	4
1.5 Approvals and Certifications	7
1.6 Disposal Instruction	7
2 Safety	8
2.1 Safety Symbols	8
2.2 Qualified Personnel	8
2.3 Safety Precautions	8
3 Mechanical Installation	10
3.1 Unpacking	10
3.2 Installation Environments	10
3.3 Mounting	11
4 Electrical Installation	13
4.1 Safety Instructions	13
4.2 EMC-compliant Installation	13
4.3 Grounding	13
4.4 Wiring Schematic	15
4.5 Access	17
4.6 Motor Connection	17
4.7 AC Line Power Connection	18
4.8 Control Wiring	18
4.8.1 Control Terminal Types	19
4.8.2 Wiring to Control Terminals	20
4.8.3 Enabling Motor Operation (Terminal 27)	20
4.8.4 Voltage/Current Input Selection (Switches)	21
4.8.5 Safe Torque Off (STO)	21
4.8.6 RS-485 Serial Communication	21
4.9 Installation Check List	22
5 Commissioning	23
5.1 Safety Instructions	23
5.2 Applying Power	23
5.3 Local Control Panel Operation	24

5.3.2 LCP Layout	24
5.3.3 Parameter Settings	26
5.3.4 Uploading/Downloading Data to/from the LCP	26
5.4 Basic Programming	27
5.4.1 Commissioning with SmartStart	27
5.4.2 Commissioning via [Main Menu]	27
5.4.3 Asynchronous Motor Set-up	28
5.4.4 PM Motor Set-up in VVC ^{plus}	28
5.4.5 Automatic Energy Optimization (AEO)	29
5.4.6 Automatic Motor Adaptation (AMA)	30
5.5 Checking Motor Rotation	30
5.6 Local Control Test	30
5.7 System Start-up	31
6 Application Set-up Examples	32
7 Maintenance, Diagnostics and Troubleshooting	36
7.1 Maintenance and Service	36
7.2 Status Messages	36
7.3 Warning and Alarm Types	38
7.4 List of Warnings and Alarms	39
7.5 Troubleshooting	45
8 Specifications	48
8.1 Electrical Data	48
8.1.1 Line Power Supply 3x200–240 V AC	48
8.1.2 Line Power Supply 3x380–480 V AC	50
8.1.3 Line Power Supply 3x525–600 V AC	52
8.2 Line Power Supply	54
8.3 Motor Output and Motor Data	55
8.4 Ambient Conditions	55
8.5 Cable Specifications	55
8.6 Control Input/Output and Control Data	56
8.7 Connection Tightening Torques	59
8.8 Fuses and Circuit Breakers	60
8.9 Power Ratings, Weight and Dimensions	67
9 Appendix	69
9.1 Symbols, Abbreviations and Conventions	69
9.2 Parameter Menu Structure	69

Index.....

73

1 Introduction

1.1 Purpose of the Manual

This instruction manual provides information for safe installation and commissioning of the adjustable frequency drive.

This instruction manual is intended for use by qualified personnel.

Read and follow the instruction manual to use the adjustable frequency drive safely and professionally, and pay particular attention to the safety instructions and general warnings. Keep this instruction manual available with the adjustable frequency drive at all times.

VLT® is a registered trademark.

1.2 Additional Resources

Other resources are available to understand advanced adjustable frequency drive functions and programming.

- The *VLT® Programming Guide* provides greater detail on working with parameters and many application examples.
- The *VLT® Design Guide* provides detailed information about capabilities and functionality to design motor control systems.
- Instructions for operation with optional equipment.

Supplementary publications and manuals are available from Danfoss. See www.danfoss.com/BusinessAreas/DrivesSolutions/Documentations/VLT+Technical+Documentation.htm for listings.

1.3 Document and Software Version

This manual is regularly reviewed and updated. All suggestions for improvement are welcome. *Table 1.1* shows the document version and the corresponding software version.

Edition	Remarks	Software version
MG16E3xx	Replaces MG16E2xx	1.21

Table 1.1 Document and Software Version

1.4 Product Overview

1.4.1 Intended Use

The adjustable frequency drive is an electronic motor controller intended for

- regulation of motor speed in response to system feedback or to remote commands from external controllers. A power drive system consists of the adjustable frequency drive, the motor and equipment driven by the motor.
- system and motor status surveillance.

The adjustable frequency drive can also be used for motor protection.

Depending on configuration, the adjustable frequency drive can be used in standalone applications or form part of a larger appliance or installation.

The adjustable frequency drive is allowed for use in residential, industrial and commercial environments in accordance with local laws and standards.

NOTICE!

In a residential environment, this product can cause radio interference, in which case supplementary mitigation measures can be required.

Foreseeable misuse

Do not use the adjustable frequency drive in applications which are non-compliant with specified operating conditions and environments. Ensure compliance with the conditions specified in *chapter 8 Specifications*.

1.4.2 Exploded Views

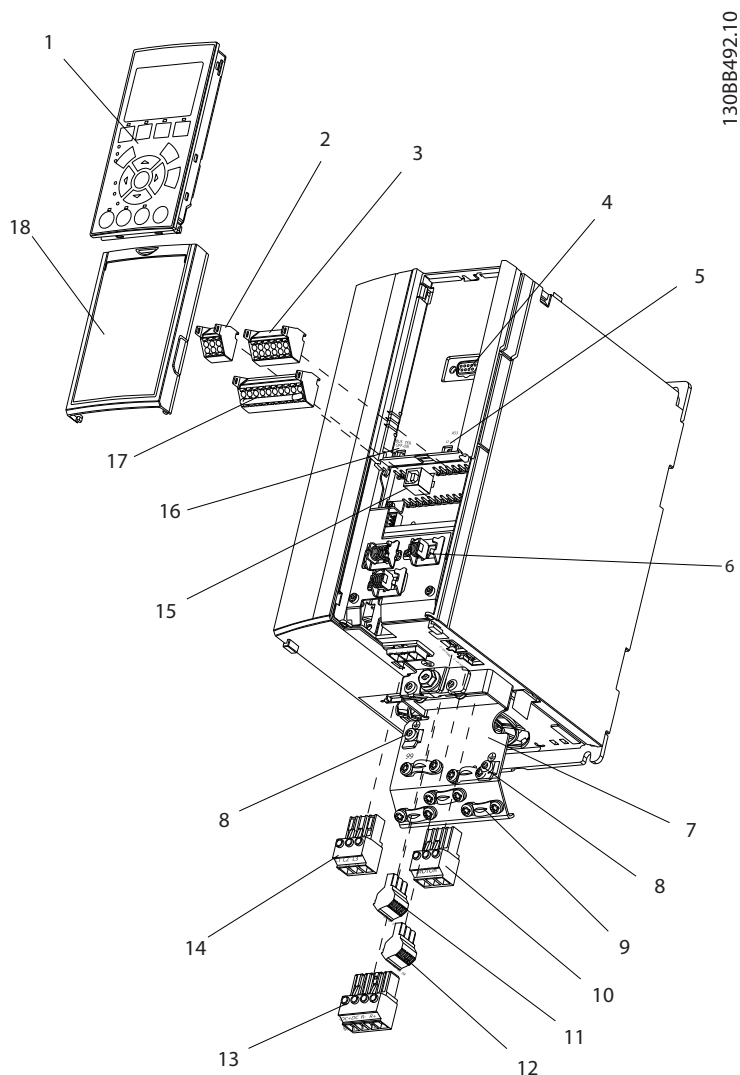

1	Local control panel (LCP)	10	Motor output terminals 96 (U), 97 (V), 98 (W)
2	RS-485 serial bus connector (+68, -69)	11	Relay 2 (04, 05, 06)
3	Analog I/O connector	12	Relay 1 (01, 02, 03)
4	LCP input plug	13	-
5	Analog switches (A53), (A54)	14	Line power input terminals 91 (L1), 92 (L2), 93 (L3)
6	Cable shield connector	15	USB connector
7	Decoupling plate	16	Serial bus terminal switch
8	Grounding clamp (PE)	17	Digital I/O and 24 V power supply
9	Shielded cable grounding clamp and strain relief	18	Cover

Figure 1.1 Exploded View Enclosure Type A, IP20

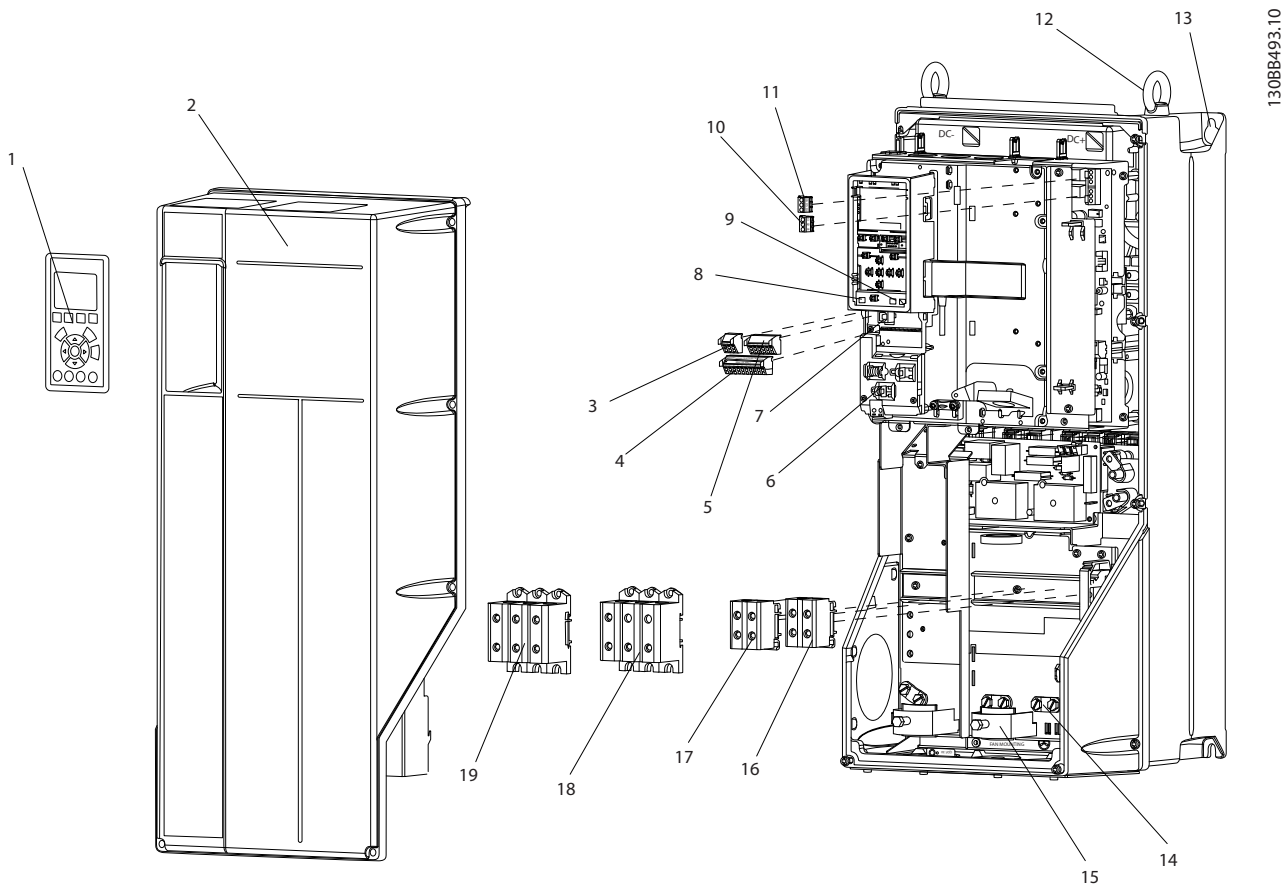

130BB493.10

1	Local control panel (LCP)	11	Relay 2 (04, 05, 06)
2	Cover	12	Lifting ring
3	RS-485 serial bus connector	13	Mounting slot
4	Digital I/O and 24 V power supply	14	Grounding clamp (PE)
5	Analog I/O connector	15	Cable shield connector
6	Cable shield connector	16	-
7	USB connector	17	-
8	Serial bus terminal switch	18	Motor output terminals 96 (U), 97 (V), 98 (W)
9	Analog switches (A53), (A54)	19	Line power input terminals 91 (L1), 92 (L2), 93 (L3)
10	Relay 1 (01, 02, 03)		

Figure 1.2 Exploded View Enclosure Types B and C, IP55 and IP66

1.4.3 Block Diagram of the Adjustable Frequency Drive

Figure 1.3 is a block diagram of the internal components of the adjustable frequency drive. See Table 1.2 for their functions.

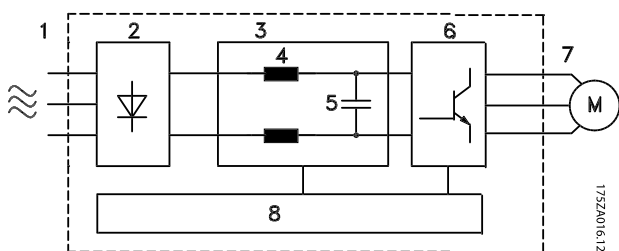

Figure 1.3 Adjustable Frequency Drive Block Diagram

Area	Title	Functions
1	Line power input	<ul style="list-style-type: none"> 3-phase AC line power supply to the adjustable frequency drive
2	Rectifier	<ul style="list-style-type: none"> The rectifier bridge converts the AC input to DC current to supply inverter power
3	DC bus	<ul style="list-style-type: none"> Intermediate DC bus circuit handles the DC current
4	DC reactors	<ul style="list-style-type: none"> Filter the intermediate DC circuit voltage Provide line transient protection Reduce RMS current Raise the power factor reflected back to the line Reduce harmonics on the AC input
5	Capacitor bank	<ul style="list-style-type: none"> Stores the DC power Provides ride-through protection for short power losses
6	Inverter	<ul style="list-style-type: none"> Converts the DC into a controlled PWM AC waveform for a controlled variable output to the motor
7	Output to motor	<ul style="list-style-type: none"> Regulated 3-phase output power to the motor

Area	Title	Functions
8	Control circuitry	<ul style="list-style-type: none"> Input power, internal processing, output, and motor current are monitored to provide efficient operation and control User interface and external commands are monitored and performed Status output and control can be provided

Table 1.2 Legend to Figure 1.3

1.4.4 Enclosure Types and Power Ratings

For enclosure types and power ratings of the adjustable frequency drives, refer to chapter 8.9 Power Ratings, Weight and Dimensions.

1.5 Approvals and Certifications



Table 1.3 Approvals and Certifications

More approvals and certifications are available. Contact local Danfoss partner.

The adjustable frequency drive complies with UL508C thermal memory retention requirements. For more information, refer to the section Motor Thermal Protection in the Design Guide.

1.6 Disposal Instruction

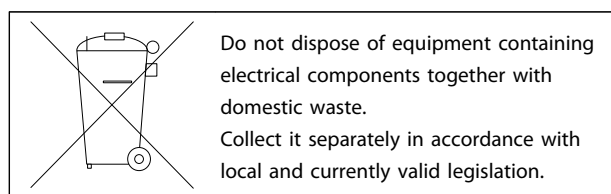

Table 1.4 Disposal Instruction

2

2 Safety

2.1 Safety Symbols

The following symbols are used in this document:

⚠ WARNING

Indicates a potentially hazardous situation which could result in death or serious injury.

⚠ CAUTION

Indicates a potentially hazardous situation which could result in minor or moderate injury. It may also be used to alert against unsafe practices.

NOTICE

Indicates important information, including situations that may result in damage to equipment or property.

2.2 Qualified Personnel

Correct and reliable transport, storage, installation, operation and maintenance are required for the trouble-free and safe operation of the adjustable frequency drive. Only qualified personnel is allowed to install or operate this equipment.

Qualified personnel is defined as trained staff, who are authorized to install, commission, and maintain equipment, systems and circuits in accordance with pertinent laws and regulations. Additionally, the personnel must be familiar with the instructions and safety measures described in this document.

2.3 Safety Precautions

⚠ WARNING**HIGH VOLTAGE**

Adjustable frequency drives contain high voltage when connected to AC line power. Failure to perform installation, start-up, and maintenance by qualified personnel could result in death or serious injury.

- Installation, start-up, and maintenance must be performed by qualified personnel only.

⚠ WARNING**UNINTENDED START**

When the adjustable frequency drive is connected to AC line power, the motor may start at any time, causing risk of death, serious injury, equipment, or property damage. The motor can start by means of an external switch, a serial bus command, an input reference signal from the LCP, or after a cleared fault condition.

- Disconnect the adjustable frequency drive from line power whenever personal safety considerations make it necessary to avoid unintended motor start.
- Press [Off] on the LCP before programming parameters.
- The adjustable frequency drive, motor, and any driven equipment must be in operational readiness when the adjustable frequency drive is connected to AC line power.

⚠ WARNING

DISCHARGE TIME

The adjustable frequency drive contains DC link capacitors that can remain charged even when the adjustable frequency drive is not powered. Failure to wait the specified time after power has been removed before performing service or repair work could result in death or serious injury.

1. Stop motor.
2. Disconnect AC line power, permanent magnet type motors, and remote DC link power supplies, including battery backups, UPS, and DC link connections to other adjustable frequency drives.
3. Wait for the capacitors to discharge fully before performing any service or repair work. The duration of waiting time is specified in *Table 2.1*.

Voltage [V]	Minimum waiting time (minutes)	
	4	15
200–240	1.5–5 hp [1.1–3.7 kW]	7.5–60 hp [5.5–45 kW]
380–500	1.5–10 hp [1.1–7.5 kW]	15–125 hp [11–90 kW]
525–600	1.5–10 hp [1.1–7.5 kW]	15–125 hp [11–90 kW]

High voltage may be present even when the warning LED indicator lights are off.

Table 2.1 Discharge Time

⚠ WARNING

LEAKAGE CURRENT HAZARD

Leakage currents exceed 3.5 mA. Failure to ground the adjustable frequency drive properly could result in death or serious injury.

- Ensure correct grounding of the equipment by a certified electrical installer.

⚠ WARNING

EQUIPMENT HAZARD

Contact with rotating shafts and electrical equipment can result in death or serious injury.

- Ensure that only trained and qualified personnel perform installation, start-up, and maintenance.
- Ensure that electrical work conforms to national and local electrical codes.
- Follow the procedures in this manual.

⚠ CAUTION

WINDMILLING

Unintended rotation of permanent magnet motors causes risk of personal injury and equipment damage.

- Ensure that permanent magnet motors are blocked to prevent unintended rotation.

⚠ CAUTION

POTENTIAL HAZARD IN THE EVENT OF INTERNAL FAILURE

Risk of personal injury when the adjustable frequency drive is not properly closed.

- Before applying power, ensure all safety covers are in place and securely fastened.

3 Mechanical Installation

3

3.1 Unpacking

3.1.1 Items Supplied

Items supplied may vary according to product configuration.

- Make sure the items supplied and the information on the nameplate correspond to the order confirmation.
- Check the packaging and the adjustable frequency drive visually for damage caused by inappropriate handling during shipment. File any claim for damage with the carrier. Retain damaged parts for clarification.

NOTICE!

Do not remove the nameplate from the adjustable frequency drive (loss of warranty).

3.1.2 Storage

Ensure that requirements for storage are fulfilled. Refer to *chapter 8.4 Ambient Conditions* for further details.

3.2 Installation Environments

NOTICE!

In environments with airborne liquids, particles, or corrosive gases, ensure that the IP/Type rating of the equipment matches the installation environment. Failure to meet requirements for ambient conditions can reduce lifetime of the adjustable frequency drive. Ensure that requirements for air humidity, temperature and altitude are met.

Vibration and Shock

The adjustable frequency drive complies with requirements for units mounted on the walls and floors of production premises, as well as in panels bolted to walls or floors.

For detailed ambient conditions specifications, refer to *chapter 8.4 Ambient Conditions*.

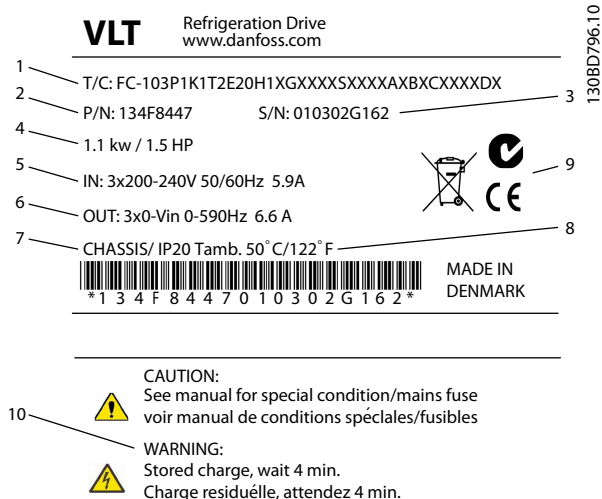

1	Type code
2	Order number
3	Serial number
4	Power rating
5	Input voltage, frequency and current (at low/high voltages)
6	Output voltage, frequency and current (at low/high voltages)
7	Enclosure type and IP rating
8	Maximum ambient temperature
9	Certifications
10	Discharge time (Warning)

Figure 3.1 Product Nameplate (Example)

3.3 Mounting

NOTICE!

Improper mounting can result in overheating and reduced performance.

Cooling

- Ensure that top and bottom clearance for air cooling is provided. See Figure 3.2 for clearance requirements.

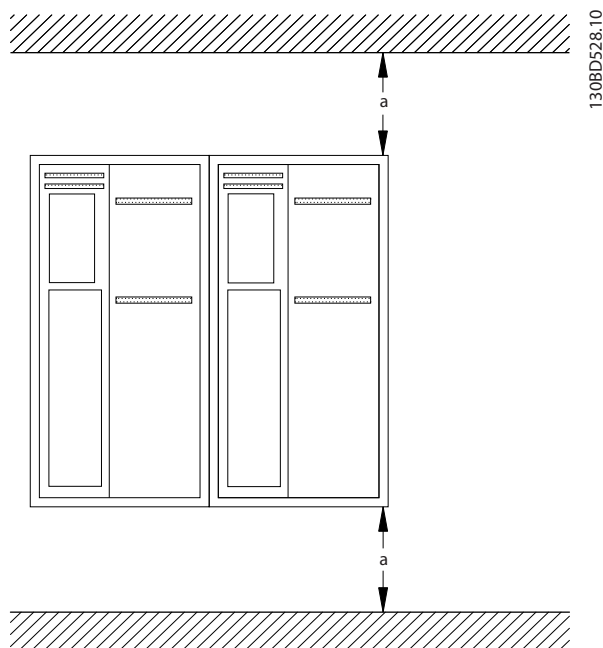

Figure 3.2 Top and Bottom Cooling Clearance

Enclosure	A2-A5	B1-B4	C1, C3	C2, C4
a (ins [mm])	3.94 [100]	7.87 [200]	7.87 [200]	8.86 [225]

Table 3.1 Minimum Airflow Clearance Requirements

Lifting

- To determine a safe lifting method, check the weight of the unit, see *chapter 8.9 Power Ratings, Weight and Dimensions*.
- Ensure that the lifting device is suitable for the task.
- If necessary, plan for a hoist, crane, or forklift with the appropriate rating to move the unit.
- For lifting, use hoist rings on the unit, when provided.

Mounting

1. Ensure that the strength of the mounting location supports the unit weight. The adjustable location frequency drive allows side-by-side installation.
2. Place the unit as near to the motor as possible. Keep the motor cables as short as possible.
3. Mount the unit vertically to a solid flat surface or to the optional backplate to provide cooling airflow.
4. Use the slotted mounting holes on the unit for wall mounting, when provided.

Mounting with backplate and railings

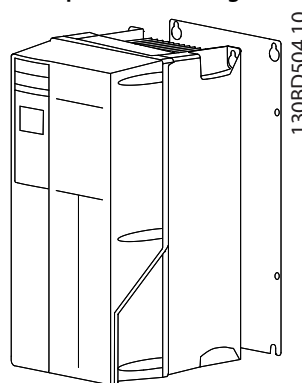

Figure 3.3 Proper Mounting with Backplate

NOTICE!

Backplate is required when mounted on railings.

NOTICE!

All A, B, and C enclosures allow side-by-side installation. Exception: if an IP21 kit is used, there has to be a clearance between the enclosures:

- For enclosures A2, A3, A4, B3, B4 and C3, the minimum clearance is 2 ins [50 mm].
- For enclosure C4, the minimum clearance is 3 ins [75 mm].

3

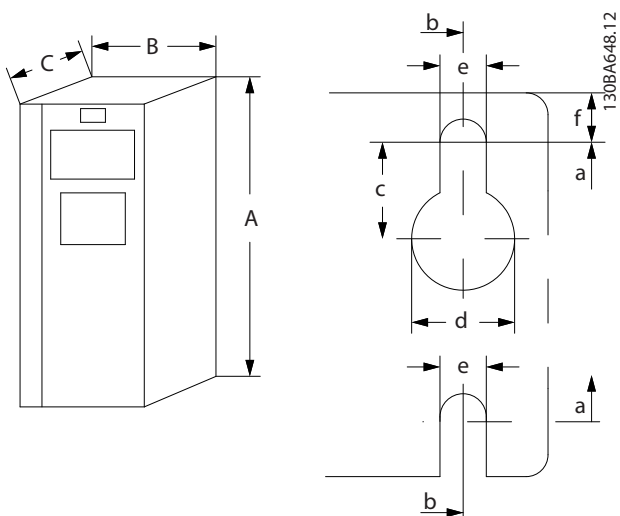

Figure 3.4 Top and Bottom Mounting Holes
(See chapter 8.9 Power Ratings, Weight and Dimensions)

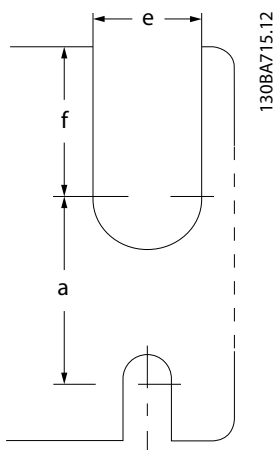

Figure 3.5 Top and Bottom Mounting Holes (B4, C3, C4)

4 Electrical Installation

4.1 Safety Instructions

See *chapter 2 Safety* for general safety instructions.

⚠ WARNING

INDUCED VOLTAGE

Induced voltage from output motor cables that run together can charge equipment capacitors even with the equipment turned off and locked out. Failure to run output motor cables separately or use shielded cables or metal conduits could result in death or serious injury.

- run output motor cables separately, or
- use shielded cables or metal conduits

⚠ CAUTION

SHOCK HAZARD

The adjustable frequency drive can cause a DC current in the PE conductor. Failure to follow the recommendation below means the RCD may not provide the intended protection.

- When a residual current-operated protective device (RCD) is used for protection against electrical shock, only an RCD of Type B is permitted on the supply side.

NOTICE!

The adjustable frequency drive is supplied with Class 20 motor overload protection.

Overcurrent Protection

- Additional protective equipment such as short-circuit protection or motor thermal protection between adjustable frequency drive and motor is required for applications with multiple motors.
- Input fusing is required to provide short circuit and overcurrent protection. If not factory-supplied, fuses must be provided by the installer. See maximum fuse ratings in *chapter 8.8 Fuses and Circuit Breakers*.

Wire Type and Ratings

- All wiring must comply with local and national regulations regarding cross-section and ambient temperature requirements.
- Power connection wire recommendation: minimum 167°F [75°C] rated copper wire.

See *chapter 8.1 Electrical Data* and *chapter 8.5 Cable Specifications* for recommended wire sizes and types.

4.2 EMC-compliant Installation

To obtain an EMC-compliant installation, follow the instructions provided in *chapter 4.3 Grounding*, *chapter 4.4 Wiring Schematic*, *chapter 4.6 Motor Connection*, and *chapter 4.8 Control Wiring*.

4.3 Grounding

⚠ WARNING

LEAKAGE CURRENT HAZARD

Leakage currents exceed 3.5 mA. Failure to ground the adjustable frequency drive properly could result in death or serious injury.

- Ensure correct grounding of the equipment by a certified electrical installer.

For electrical safety

- Ground the adjustable frequency drive in accordance with applicable standards and directives.
- Use a dedicated ground wire for input power, motor power and control wiring.
- Do not ground one adjustable frequency drive to another in a "daisy chain" fashion.
- Keep the ground wire connections as short as possible.
- Follow the motor manufacturer wiring requirements.
- Minimum cable cross-section: AWG 7 [10 mm²] (or two rated ground wires terminated separately).

For EMC-compliant installation

- Establish electrical contact between cable shield and adjustable frequency drive enclosure by using metal cable connectors or by using the clamps provided on the equipment (see *chapter 4.6 Motor Connection*).
- Use high-strand wire to reduce electrical interference.
- Do not use pigtails.

NOTICE!**POTENTIAL EQUALIZATION**

Risk of electrical interference, when the ground potential between the adjustable frequency drive and the system is different. Install equalizing cables between the system components. Recommended cable cross-section: AWG 6 [16 mm²].

4.4 Wiring Schematic

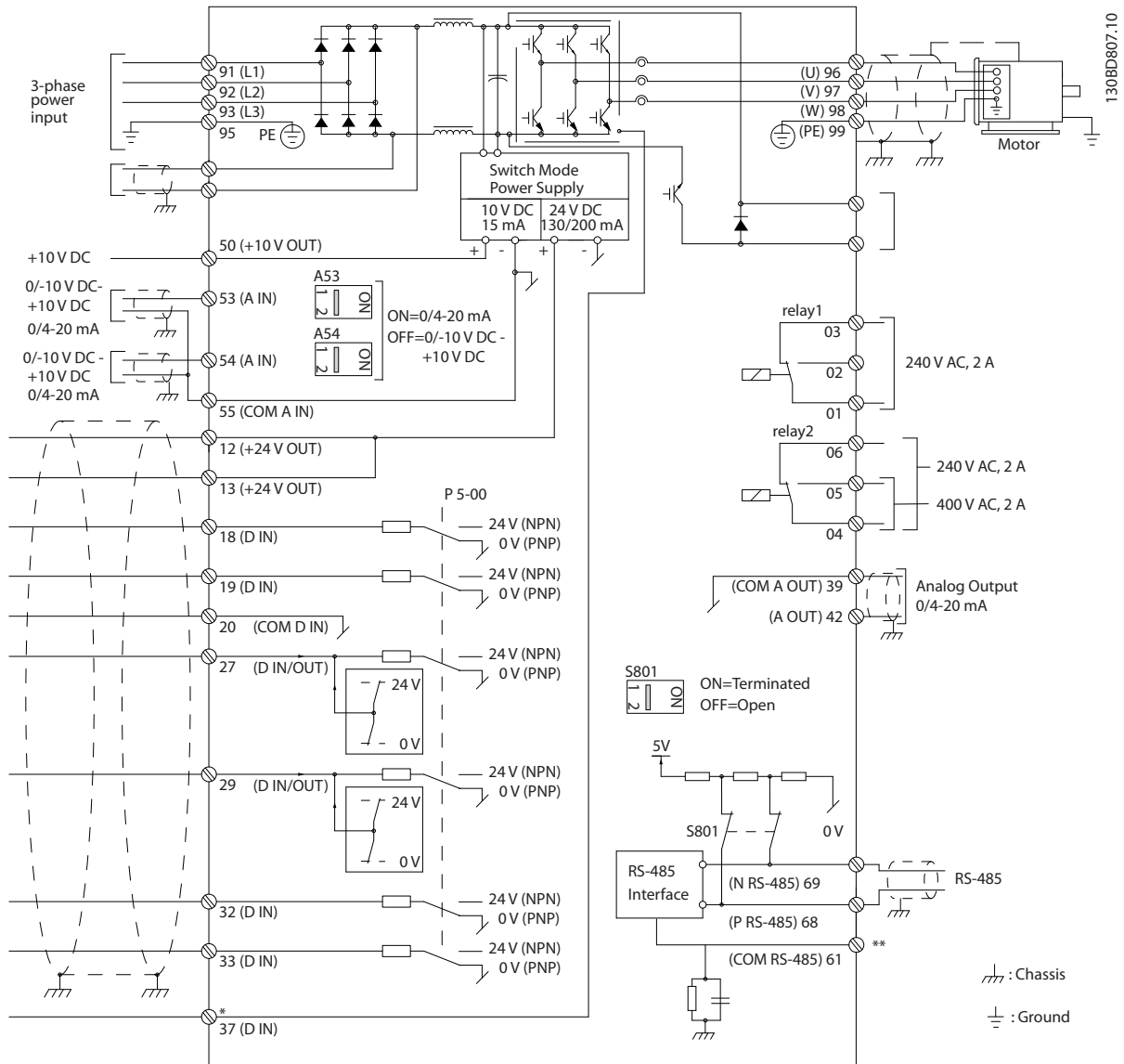
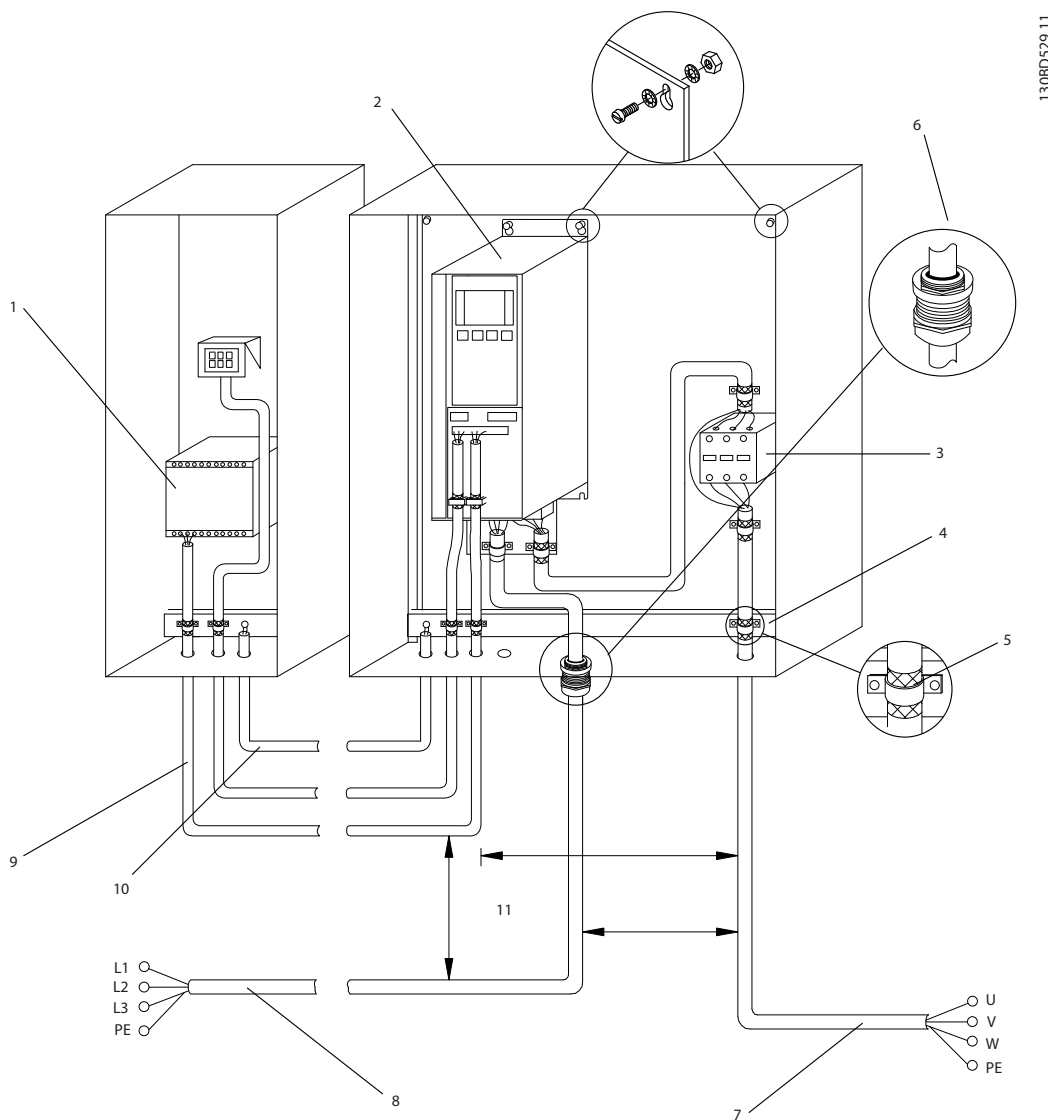

Figure 4.1 Basic Wiring Schematic

A=Analog, D=Digital

*Terminal 37 (optional) is used for Safe Torque Off. For Safe Torque Off installation instructions, refer to the *VLT® Adjustable Frequency Drives - Safe Torque Off Instruction Manual*.

**Do not connect cable shield.



1308D529.11

1	PLC	6	Cable connector
2	Adjustable frequency drive	7	Motor, 3-phase and PE
3	Output contactor	8	Line power, 3-phase and reinforced PE
4	Grounding rail (PE)	9	Control wiring
5	Cable insulation (stripped)	10	Equalizing min. 0.025 in ² [16 mm ²]

Figure 4.2 EMC-compliant Electrical Connection

NOTICE

EMC INTERFERENCE

Run cables for input power, motor wiring and control wiring in three separate metallic conduits. Failure to isolate power, motor and control cables can result in unintended behavior or reduced performance. Minimum 7.9 in [200 mm] clearance between power, motor and control cables is required.

4.5 Access

- Remove cover with a screwdriver (See Figure 4.3) or by loosening attaching screws (See Figure 4.4).

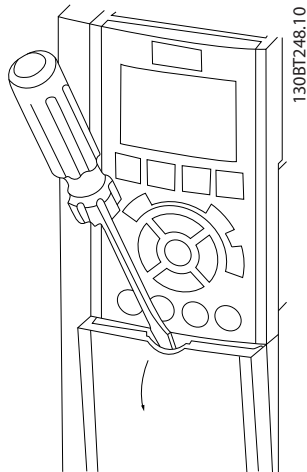

Figure 4.3 Access to Wiring for IP20 and IP21 Enclosures

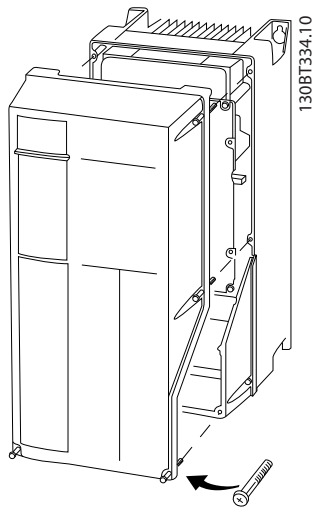

Figure 4.4 Access to Wiring for IP55 and IP66 Enclosures

See Table 4.1 before tightening the covers.

Enclosure	IP55	IP66
A4/A5	2	2
B1/B2	2.2	2.2
C1/C2	2.2	2.2
No screws to tighten for A2/A3/B3/B4/C3/C4.		

Table 4.1 Tightening Torques for Covers [Nm]

4.6 Motor Connection

WARNING

INDUCED VOLTAGE

Induced voltage from output motor cables that run together can charge equipment capacitors even with the equipment turned off and locked out. Failure to run output motor cables separately or use shielded cables or metal conduits could result in death or serious injury.

- run output motor cables separately, or
- use shielded cables or metal conduits
- Comply with local and national electrical codes for cable sizes. For maximum wire sizes, see *chapter 8.1 Electrical Data*.
- Follow the motor manufacturer wiring requirements.
- Motor wiring knockouts or access panels are provided at the base of IP21 (NEMA1/12) and higher units.
- Do not wire a starting or pole-changing device (e.g., Dahlander motor or slip ring induction motor) between the adjustable frequency drive and the motor.

Procedure

- Strip a section of the outer cable insulation.
- Position the stripped wire under the cable clamp to establish mechanical fixation and electrical contact between cable shield and ground.
- Connect ground wire to the nearest grounding terminal in accordance with grounding instructions provided in *chapter 4.3 Grounding*, see *Figure 4.5*.
- Connect the 3-phase motor wiring to terminals 96 (U), 97 (V), and 98 (W), see *Figure 4.5*.
- Tighten terminals in accordance with the information provided in *chapter 8.7 Connection Tightening Torques*.

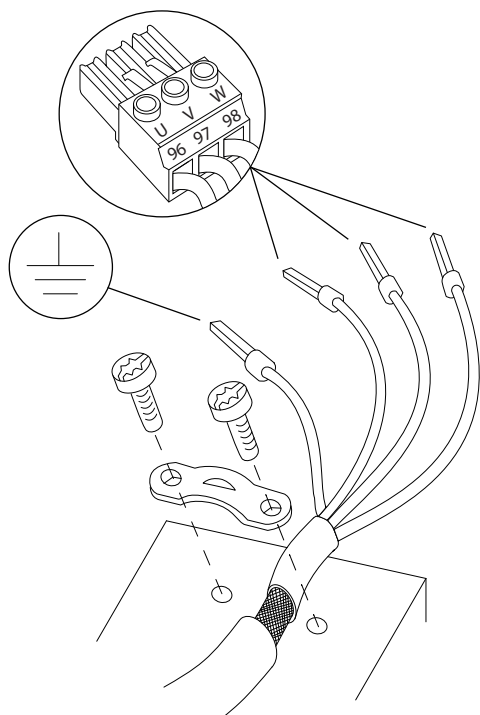

130BD531.10

Figure 4.5 Motor Connection

Figure 4.6 represents line power input, motor, and grounding for basic adjustable frequency drives. Actual configurations vary with unit types and optional equipment.

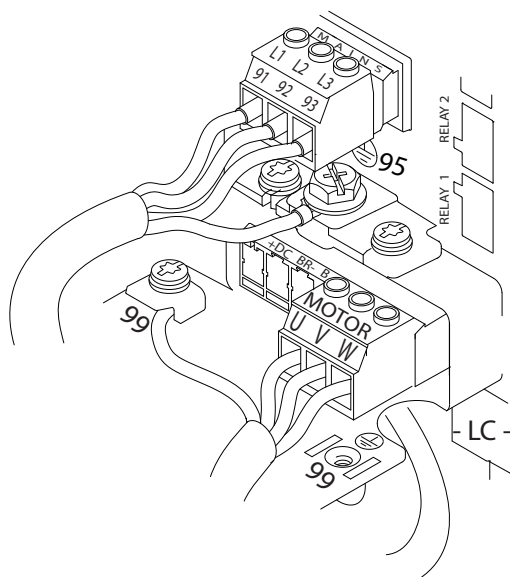

130BB920.10

Figure 4.6 Example of Motor, Line Power and Ground Wiring

4.7 AC Line Power Connection

- Size wiring based upon the input current of the adjustable frequency drive. For maximum wire sizes, see *chapter 8.1 Electrical Data*.
- Comply with local and national electrical codes for cable sizes.

Procedure

1. Connect 3-phase AC input power wiring to terminals L1, L2, and L3 (see *Figure 4.6*).
2. Depending on the configuration of the equipment, input power is connected to the line power input terminals or the input disconnect.
3. Ground the cable in accordance with grounding instructions provided in *chapter 4.3 Grounding*.
4. When supplied from an isolated line power source (IT line power or floating delta) or TT/TN-S line power with a grounded leg (grounded delta), ensure that *14-50 RFI 1* is set to *[0] Off* to avoid damage to the intermediate circuit and to reduce ground capacity currents in accordance with IEC 61800-3.

4.8 Control Wiring

- Isolate control wiring from high power components in the adjustable frequency drive.
- When the adjustable frequency drive is connected to a thermistor, ensure that the thermistor control wiring is shielded and reinforced/double insulated. A 24 V DC supply voltage is recommended.

4.8.1 Control Terminal Types

Figure 4.7 and Figure 4.8 show the removable adjustable frequency drive connectors. Terminal functions and default settings are summarized in Table 4.2.

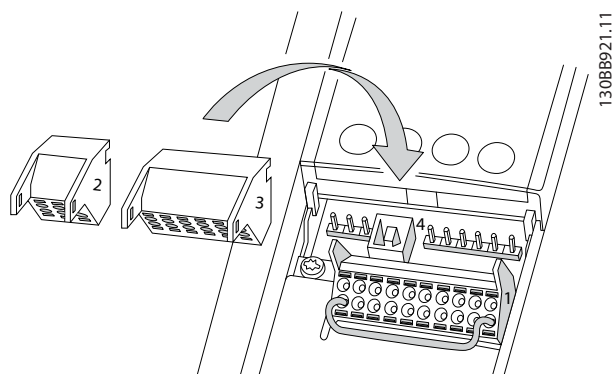

Figure 4.7 Control Terminal Locations

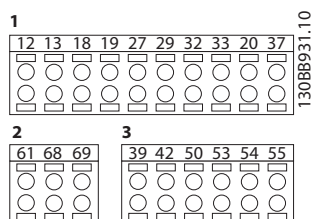

Figure 4.8 Terminal Numbers

- **Connector 1** provides four programmable digital inputs terminals, two additional digital terminals programmable as either input or output, a 24 V DC terminal supply voltage, and a common for optional customer supplied 24 V DC voltage
- **Connector 2** terminals (+)68 and (-)69 are for an RS-485 serial communication connection
- **Connector 3** provides two analog inputs, one analog output, 10 V DC supply voltage, and commons for the inputs and output
- **Connector 4** is a USB port available for use with the MCT 10 Set-up Software

Digital Inputs/Outputs			
Terminal	Parameter	Default setting	Description
12, 13	-	+24 V DC	24 V DC supply voltage. Maximum output current is 200 mA total for all 24 V loads. Usable for digital inputs and external transducers.
18	5-10	[8] Start	Digital inputs.
19	5-11	[10] Reversing	
32	5-14	[39] Day/Night Control	
33	5-15	[0] No operation	
27	5-12	[2] Coast inverse	Selectable for either digital input or output. Default setting is input.
29	5-13	[0] No operation	
20	-		Common for digital inputs and 0 V potential for 24 V supply.
37	-	Safe Torque Off (STO)	(Optional) Safe input. Used for STO
Analog Inputs/Outputs			
39	-		Common for analog output.
42	6-50	[100] Output frequency	Programmable analog output. The analog signal is 0–20 mA or 4–20 mA at a maximum of 500 Ω.
50	-	+10 V DC	10 V DC analog supply voltage. 15 mA maximum commonly used for potentiometer or thermistor.
53	6-1*	Reference	Analog input.
54	6-2*	Feedback	Selectable for voltage or current. Switches A53 and A54 select mA or V.
55	-		Common for analog input.
Serial Communication			
61	-		Integrated RC filter for cable shield. ONLY for connecting the shield when experiencing EMC problems.

Digital Inputs/Outputs			
Terminal	Parameter	Default setting	Description
68 (+)	8-3*		RS-485 Interface. A control card switch is provided for termination resistance.
69 (-)	8-3*		
Relays			
01, 02, 03	5-40	[2] Drive ready	Form C relay output.
04, 05, 06	5-40	[5] Running	Usable for AC or DC voltage and resistive or inductive loads.

Table 4.2 Terminal Description

Additional terminals:

- two form C relay outputs. Location of the outputs depends on adjustable frequency drive configuration.
- Terminals located on built-in optional equipment. See the manual provided with the equipment option.

4.8.2 Wiring to Control Terminals

Control terminal connectors can be unplugged from the adjustable frequency drive for ease of installation, as shown in *Figure 4.7*.

NOTICE!

Keep control wires as short as possible and separate from high power cables to minimize interference.

1. Open the contact by inserting a small screwdriver into the slot above the contact and push the screwdriver slightly upwards.

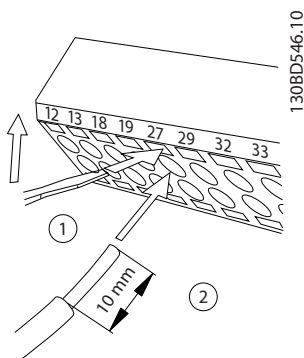

Figure 4.9 Connecting Control Wires

2. Insert the bared control wire into the contact.
3. Remove the screwdriver to fasten the control wire into the contact.
4. Ensure the contact is firmly established and not loose. Loose control wiring can be the source of equipment faults or less than optimal operation.

See *chapter 8.5 Cable Specifications* for control terminal wiring sizes and *chapter 6 Application Set-up Examples* for typical control wiring connections.

4.8.3 Enabling Motor Operation (Terminal 27)

A jumper wire may be required between terminal 12 (or 13) and terminal 27 for the adjustable frequency drive to operate when using factory default programming values.

- Digital input terminal 27 is designed to receive an 24 V DC external interlock command. In many applications, the user wires an external interlock device to terminal 27.
- When no interlock device is used, wire a jumper between control terminal 12 (recommended) or 13 to terminal 27. This provides an internal 24 V signal on terminal 27.
- When the status line at the bottom of the LCP reads AUTO REMOTE COAST, this indicates that the unit is ready to operate but is missing an input signal on terminal 27.
- When factory installed optional equipment is wired to terminal 27, do not remove that wiring.

NOTICE!

The adjustable frequency drive cannot operate without a signal on terminal 27 unless terminal 27 is re-programmed.

4.8.4 Voltage/Current Input Selection (Switches)

The analog input terminals 53 and 54 allow setting of input signal to voltage (0–10 V) or current (0/4–20 mA).

Default parameter settings:

- Terminal 53: speed reference signal in open-loop (see 16-61 Terminal 53 Switch Setting).
- Terminal 54: feedback signal in closed-loop (see 16-63 Terminal 54 Switch Setting).

NOTICE!

Disconnect power to the adjustable frequency drive before changing switch positions.

1. Remove the local control panel (see Figure 4.10).
2. Remove any optional equipment covering the switches.
3. Set switches A53 and A54 to select the signal type. U selects voltage, I selects current.

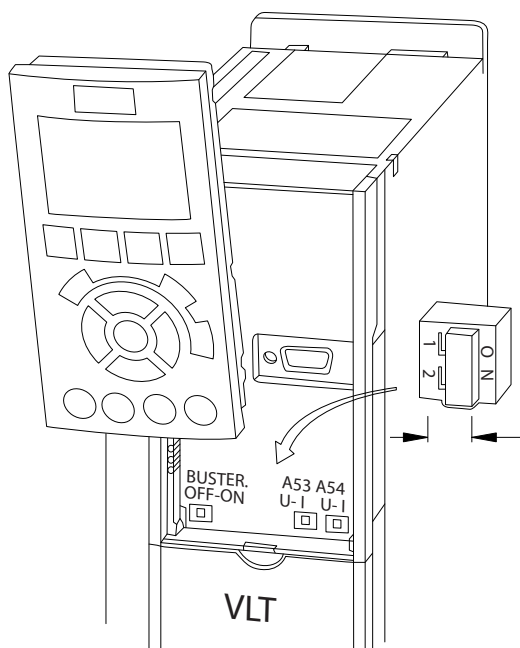

Figure 4.10 Location of Terminals 53 and 54 Switches

4.8.5 Safe Torque Off (STO)

To run Safe Torque Off, additional wiring for the adjustable frequency drive is required, refer to *Safe Torque Off Instruction Manual for Danfoss VLT® Adjustable Frequency Drives* for further information.

4.8.6 RS-485 Serial Communication

Connect RS-485 serial communication wiring to terminals (+)68 and (-)69.

- Use shielded serial communication cable (recommended)
- See chapter 4.3 Grounding for proper grounding.

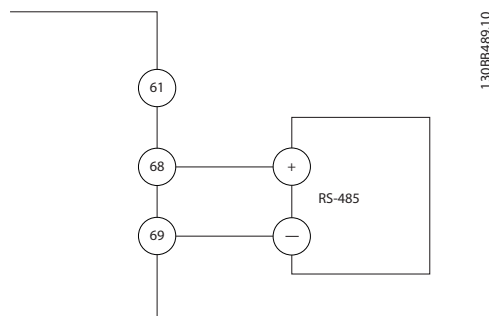

Figure 4.11 Serial Communication Wiring Diagram

For basic serial communication set-up, select the following:

1. Protocol type in 8-30 Protocol.
 2. Adjustable frequency drive address in 8-31 Address.
 3. Baud rate in 8-32 Baud Rate.
- Communication protocols are internal to the adjustable frequency drive.
 - [0] FC Profile
 - [1] FC/MC Profile
 - [2] Modbus RTU
 - [3] Metasys N2
 - [9] FC Option
 - Functions can be programmed remotely using the protocol software and RS-485 connection or in parameter group 8-** Communications and Options.
 - Selecting a specific communication protocol changes various default parameter settings to match that protocol's specifications along with making additional protocol-specific parameters available.
 - Option cards which can be installed in the adjustable frequency drive are available to provide additional communication protocols. See the option-card documentation for installation and operation instructions.

4.9 Installation Check List

Before completing installation of the unit, inspect the entire installation as detailed in *Table 4.3*. Check and mark the items when completed.

Inspect for	Description	<input checked="" type="checkbox"/>
Auxiliary equipment	<ul style="list-style-type: none"> Look for auxiliary equipment, switches, disconnects, or input fuses/circuit breakers that may reside on the input power side of the adjustable frequency drive or output side to the motor. Ensure that they are ready for full-speed operation Check function and installation of any sensors used for feedback to the adjustable frequency drive. Remove any power factor correction caps on motor(s) Adjust any power factor correction caps on the line power side and ensure that they are dampened 	
Cable routing	<ul style="list-style-type: none"> Ensure that motor wiring and control wiring are separated or shielded or in three separate metallic conduits for high-frequency interference isolation 	
Control wiring	<ul style="list-style-type: none"> Check for broken or damaged wires and loose connections. Check that control wiring is isolated from power and motor wiring for noise immunity. Check the voltage source of the signals, if necessary. The use of shielded cable or twisted pair is recommended. Ensure that the shield is terminated correctly. 	
Cooling clearance	<ul style="list-style-type: none"> Measure that top and bottom clearance is adequate to ensure proper air flow for cooling, see <i>chapter 3.3 Mounting</i> 	
Ambient conditions	<ul style="list-style-type: none"> Check that requirements for ambient conditions are met 	
Fusing and circuit breakers	<ul style="list-style-type: none"> Check for proper fusing or circuit breakers. Check that all fuses are inserted firmly and are in operational condition and that all circuit breakers are in the open position 	
Grounding	<ul style="list-style-type: none"> Check for sufficient ground connections that are tight and free of oxidation Grounding to conduit or mounting the back panel to a metal surface is not a suitable grounding 	
Input and output power wiring	<ul style="list-style-type: none"> Check for loose connections. Check that motor and line power are in separate conduits or separated shielded cables. 	
Panel interior	<ul style="list-style-type: none"> Make sure that the unit interior is free of dirt, metal chips, moisture, and corrosion. Check that the unit is mounted on an unpainted, metal surface. 	
Switches	<ul style="list-style-type: none"> Ensure that all switch and disconnect settings are in the proper positions. 	
Vibration	<ul style="list-style-type: none"> Check that the unit is mounted solidly or that shock mounts are used, as necessary. Check for an unusual amount of vibration. 	

Table 4.3 Installation Check List

CAUTION

POTENTIAL HAZARD IN THE EVENT OF INTERNAL FAILURE

Risk of personal injury when the adjustable frequency drive is not properly closed.

- Before applying power, ensure all safety covers are in place and securely fastened.

5 Commissioning

5.1 Safety Instructions

See *chapter 2 Safety* for general safety instructions.

⚠ WARNING

HIGH VOLTAGE

Adjustable frequency drives contain high voltage when connected to AC line input power. Failure to perform installation, start-up, and maintenance by qualified personnel could result in death or serious injury.

- Installation, start-up, and maintenance must be performed by qualified personnel only.

Before applying power:

1. Close cover properly.
2. Check that all cable connectors are firmly tightened.
3. Ensure that input power to the unit is OFF and locked out. Do not rely on the adjustable frequency drive disconnect switches for input power isolation.
4. Verify that there is no voltage on input terminals L1 (91), L2 (92), and L3 (93), phase-to-phase and phase-to-ground.
5. Verify that there is no voltage on output terminals 96 (U), 97 (V), and 98 (W), phase-to-phase and phase-to-ground.
6. Confirm continuity of the motor by measuring ohm values on U-V (96-97), V-W (97-98), and W-U (98-96).
7. Check for proper grounding of the adjustable frequency drive as well as the motor.
8. Inspect the adjustable frequency drive for loose connections on terminals.
9. Confirm that the supply voltage matches voltage of adjustable frequency drive and motor.

5.2 Applying Power

⚠ WARNING

UNINTENDED START

When the adjustable frequency drive is connected to AC line power, the motor may start at any time, causing risk of death, serious injury, equipment, or property damage. The motor can start by means of an external switch, a serial bus command, an input reference signal from the LCP, or after a cleared fault condition.

- Disconnect the adjustable frequency drive from line power whenever personal safety considerations make it necessary to avoid unintended motor start.
- Press [Off] on the LCP before programming parameters.
- The adjustable frequency drive, motor, and any driven equipment must be in operational readiness when the adjustable frequency drive is connected to AC line power.

Apply power to the adjustable frequency drive using the following steps:

1. Confirm that the input voltage is balanced within 3%. If not, correct input voltage imbalance before proceeding. Repeat this procedure after the voltage correction.
2. Ensure that optional equipment wiring, if present, matches the installation application.
3. Ensure that all operator devices are in the OFF position. Panel doors must be closed or cover mounted.
4. Apply power to the unit. DO NOT start the adjustable frequency drive now. For units with a disconnect switch, turn to the ON position to apply power to the adjustable frequency drive.

NOTICE!

When the status line at the bottom of the LCP reads **AUTO REMOTE COASTING** or *Alarm 60 External Interlock* is displayed, this message indicates that the unit is ready to operate but is missing an input signal on, for example, terminal 27. See *chapter 4.8.3 Enabling Motor Operation (Terminal 27)* for details.

5.3 Local Control Panel Operation

5.3.1 Local Control Panel

The local control panel (LCP) is the combined display and keypad on the front of the unit.

The LCP has several user functions:

- Start, stop, and control speed when in local control
- Display operational data, status, warnings and cautions
- Programming adjustable frequency drive functions
- Manually reset the adjustable frequency drive after a fault when auto-reset is inactive

NOTICE!

For commissioning via PC, install MCT 10 Set-up Software. The software is available for download (basic version) or for ordering (advanced version, order number 130B1000). For more information and downloads, see www.danfoss.com/BusinessAreas/DrivesSolutions/Software+MCT10/MCT10+Downloads.htm.

5.3.2 LCP Layout

The LCP is divided into four functional groups (see Figure 5.1).

- A. Display area
- B. Display menu keys
- C. Navigation keys and LEDs
- D. Operation keys and reset

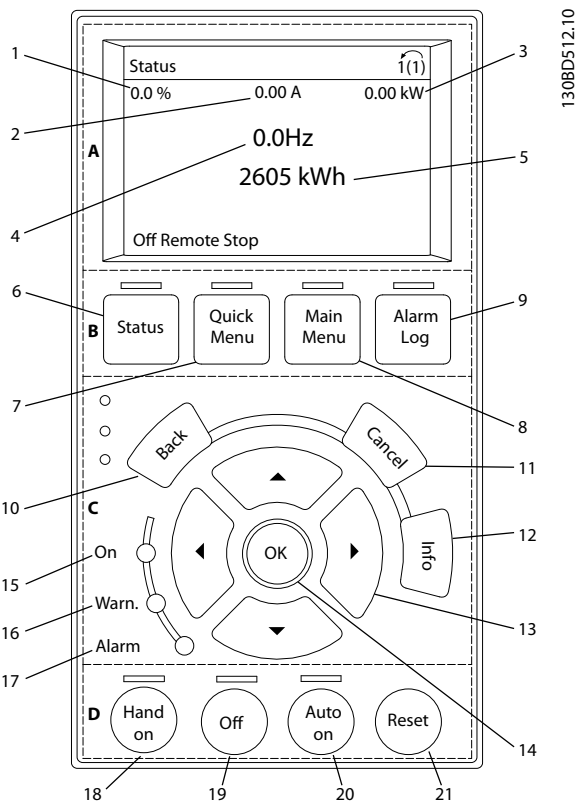

Figure 5.1 Local Control Panel (LCP)

A. Display Area

The display area is activated when the adjustable frequency drive receives power from AC line voltage, a DC bus terminal, or an external 24 V DC supply.

The information displayed on the LCP can be customized for user application. Select options in the Quick Menu Q3-13 Display Settings.

Callout	Display	Parameter number	Default setting
1	1.1	0-20	Reference %
2	1.2	0-21	Motor current
3	1.3	0-22	Power [kW]
4	2	0-23	Frequency
5	3	0-24	kWh counter

Table 5.1 Legend to Figure 5.1, Display Area

B. Display Menu Keys

Menu keys are used for menu access for parameter set-up, toggling through status display modes during normal operation, and viewing fault log data.

Callout	Key	Function
6	Status	Shows operational information.
7	Quick Menu	Allows access to programming parameters for initial set-up instructions and many detailed application instructions.
8	Main Menu	Allows access to all programming parameters.
9	Alarm Log	Displays a list of current warnings, the last ten alarms, and the maintenance log.

Table 5.2 Legend to Figure 5.1, Display Menu Keys

C. Navigation Keys and Indicator Lights (LEDs)

Navigation keys are used for programming functions and moving the display cursor. The navigation keys also provide speed control in local (hand) operation. There are also three adjustable frequency drive status indicator lights in this area.

Callout	Key	Function
10	Back	Reverts to the previous step or list in the menu structure.
11	Cancel	Cancels the last change or command as long as the display mode has not changed.
12	Indo	Press for a definition of the function being displayed.
13	Navigation keys	Press to move between items in the menu.
14	OK	Press to access parameter groups or to enable a choice.

Table 5.3 Legend to Figure 5.1, Navigation Keys

Callout	Indicator	Light	Function
15	ON	Green	The ON light activates when the adjustable frequency drive receives power from AC line voltage, a DC bus terminal, or an external 24 V supply.
16	WARN	Yellow	When warning conditions are met, the yellow WARN light comes on and text appears in the display area identifying the problem.
17	ALARM	Red	A fault condition causes the red alarm light to flash and an alarm text is displayed.

Table 5.4 Legend to Figure 5.1, Indicator Lights (LEDs)

D. Operation Keys and Reset

Operation keys are located at the bottom of the LCP.

Callout	Key	Function
18	Hand On	Starts the adjustable frequency drive in local control. <ul style="list-style-type: none"> An external stop signal by control input or serial communication overrides the local hand on
19	Off	Stops the motor but does not remove power to the adjustable frequency drive.
20	Auto On	Puts the system in remote operational mode. <ul style="list-style-type: none"> Responds to an external start command by control terminals or serial communication
21	Reset	Resets the adjustable frequency drive manually after a fault has been cleared.

Table 5.5 Legend to Figure 5.1, Operation Keys and Reset

NOTICE!

The display contrast can be adjusted by pressing [Status] and [▲]/[▼] keys.

5.3.3 Parameter Settings

Establishing the correct programming for applications often requires setting functions in several related parameters. Details for parameters are provided in *chapter 9.2 Parameter Menu Structure*.

Programming data are stored internally in the adjustable frequency drive.

- For backup, upload data into the LCP memory
- To download data to another adjustable frequency drive, connect the LCP to that unit and download the stored settings
- Restoring factory default settings does not change data stored in the LCP memory

5.3.4 Uploading/Downloading Data to/from the LCP

1. Press [Off] to stop the motor before uploading or downloading data.
2. Go to [Main Menu] *0-50 LCP Copy* and press [OK].
3. Select [1] *All to LCP* to upload data to LCP or select [2] *All from LCP* to download data from the LCP.
4. Press [OK]. A progress bar shows the uploading or downloading process.
5. Press [Hand On] or [Auto On] to return to normal operation.

5.3.5 Changing Parameter Settings

Parameter settings can be accessed and changed from the [Quick Menu] or from the [Main Menu]. The [Quick Menu] only gives access to a limited number of parameters.

1. Press [Quick Menu] or [Main Menu] on the LCP.
2. Press [▲] [▼] to browse through the parameter groups, press [OK] to select a parameter group.
3. Press [▲] [▼] to browse through the parameters, press [OK] to select a parameter.
4. Press [▲] [▼] to change the value of a parameter setting.

5. Press [◀] [▶] to shift digit when a decimal parameter is in the editing state.
6. Press [OK] to accept the change.
7. Press either [Back] twice to enter Status, or press [Main Menu] once to enter Main Menu.

View changes

Quick Menu Q5 - Changes Made lists all parameters changed from default settings.

- The list shows only parameters which have been changed in the current edit set-up.
- Parameters which have been reset to default values are not listed.
- The message *Empty* indicates that no parameters have been changed.

5.3.6 Restoring Default Settings

NOTICE!

Risk of losing programming, motor data, localization, and monitoring records by restoration of default settings. To provide a backup, upload data to the LCP before initialization.

Restoring the default parameter settings is done by initialization of the adjustable frequency drive. Initialization is carried out through *14-22 Operation Mode* (recommended) or manually.

- Initialization using *14-22 Operation Mode* does not reset adjustable frequency drive settings such as operating hours, serial communication selections, personal menu settings, fault log, alarm log, and other monitoring functions.
- Manual initialization erases all motor, programming, localization, and monitoring data and restores factory default settings.

Recommended initialization procedure, via 14-22 Operation Mode

1. Press [Main Menu] twice to access parameters.
2. Scroll to *14-22 Operation Mode* and press [OK].
3. Scroll to *Initialization* and press [OK].
4. Remove power to the unit and wait for the display to turn off.
5. Apply power to the unit.

Default parameter settings are restored during start-up. This may take slightly longer than normal.

6. Alarm 80 is displayed.
7. Press [Reset] to return to operation mode.

Manual initialization procedure

1. Remove power to the unit and wait for the display to turn off.
2. Press and hold [Status], [Main Menu], and [OK] at the same time while applying power to the unit (approximately 5 s or until audible click and fan starts).

Factory default parameter settings are restored during start-up. This may take slightly longer than normal.

Manual initialization does not reset the following adjustable frequency drive information:

- 15-00 Operating hours
- 15-03 Power-ups
- 15-04 Over Temps
- 15-05 Over Volts

5.4 Basic Programming

5.4.1 Commissioning with SmartStart

The SmartStart wizard enables fast configuration of basic motor and application parameters.

- At first power-up or after initialization of the adjustable frequency drive, SmartStart starts automatically.
- Follow on-screen instructions to complete commissioning of the adjustable frequency drive. Always reactivate SmartStart by selecting *Quick Menu Q4 - SmartStart*.
- For commissioning without use of the SmartStart wizard, refer to *chapter 5.4.2 Commissioning via [Main Menu]* or the *Programming Guide*.

NOTICE!

Motor data are required for the SmartStart set-up. The required data are normally available on the motor nameplate.

5.4.2 Commissioning via [Main Menu]

Recommended parameter settings are intended for start-up and checkout purposes. Application settings may vary.

Enter data with power ON, but before operating the adjustable frequency drive.

1. Press [Main Menu] on the LCP.
2. Press the navigation keys to scroll to parameter group *0-** Operation/Display* and press [OK].

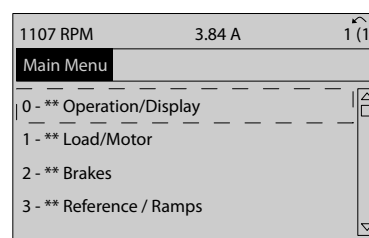

130BP066.10

Figure 5.2 Main Menu

- Press navigation keys to scroll to parameter group *0-0* Basic Settings* and press [OK].

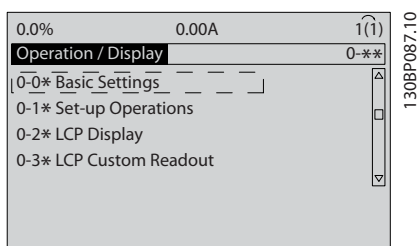

Figure 5.3 Operation/Display

- Press navigation keys to scroll to *0-03 Regional Settings* and press [OK].

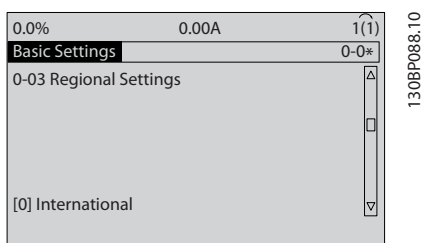

Figure 5.4 Basic Settings

- Press navigation keys to select *[0] International* or *[1] North America* as appropriate and press [OK]. (This changes the default settings for a number of basic parameters).
- Press [Main Menu] on the LCP.
- Press the navigation keys to scroll to *0-01 Language*.
- Select language and press [OK].
- If a jumper wire is in place between control terminals 12 and 27, leave *5-12 Terminal 27 Digital Input* at factory default. Otherwise, select *No Operation* in *5-12 Terminal 27 Digital Input*. For adjustable frequency drives with an optional bypass, no jumper wire is required between control terminals 12 and 27.
- 3-02 Minimum Reference*
- 3-03 Maximum Reference*
- 3-41 Ramp 1 Ramp-up Time*
- 3-42 Ramp 1 Ramp-down Time*
- 3-13 Reference Site*. Linked to Hand/Auto Local Remote.

5.4.3 Asynchronous Motor Set-up

Enter the motor data in parameter *1-20 Motor Power [kW]* or *1-21 Motor Power [HP]* to *1-25 Motor Nominal Speed*. The information can be found on the motor nameplate.

- 1-20 Motor Power [kW]* or *1-21 Motor Power [HP]*
- 1-22 Motor Voltage*
- 1-23 Motor Frequency*
- 1-24 Motor Current*
- 1-25 Motor Nominal Speed*

5.4.4 PM Motor Set-up in VVC^{plus}

NOTICE!

Only use permanent magnet (PM) motor with fans and pumps.

Initial Programming Steps

- Activate PM motor operation *1-10 Motor Construction*, select (1) *PM, non-salient SPM*
- Set *0-02 Motor Speed Unit* to *[0] RPM*

Programming motor data

After selecting PM motor in *1-10 Motor Construction*, the PM motor-related parameters in parameter groups *1-2* Motor Data*, *1-3* Addl. Motor Data* and *1-4** are active. The necessary data can be found on the motor nameplate and in the motor data sheet.

Program the following parameters in the listed order

- 1-24 Motor Current*
- 1-26 Motor Cont. Rated Torque*
- 1-25 Motor Nominal Speed*
- 1-39 Motor Poles*
- 1-30 Stator Resistance (Rs)*
Enter line to common stator winding resistance (Rs). If only line-line data are available, divide the line-line value by 2 to achieve the line to common (starpoint) value.
- 1-37 d-axis Inductance (Ld)*
Enter line to common direct axis inductance of the PM motor.
If only line-line data are available, divide the line-line value by 2 to achieve the line-common (starpoint) value.

7. **1-40 Back EMF at 1000 RPM**
 Enter line-to-line back EMF of PM Motor at 1000 RPM mechanical speed (RMS value). Back EMF is the voltage generated by a PM motor when no drive is connected and the shaft is turned externally. Back EMF is normally specified for nominal motor speed or for 1,000 RPM measured between two lines. If the value is not available for a motor speed of 1000 RPM, calculate the correct value as follows: If back EMF is, e.g., 320 V at 1800 RPM, it can be calculated at 1000 RPM as follows: Back EMF = (Voltage / RPM)*1000 = (320/1800)*1000 = 178. This is the value that must be programmed for *1-40 Back EMF at 1000 RPM*.

Test Motor Operation

1. Start the motor at low speed (100 to 200 RPM). If the motor does not turn, check installation, general programming and motor data.
2. Check if start function in *1-70 PM Start Mode* fits the application requirements.

Rotor detection

This function is the recommended choice for applications where the motor starts from standstill, e.g., pumps or conveyors. On some motors, an acoustic sound is heard when the impulse is sent out. This does not harm the motor.

Parking

This function is the recommended choice for applications where the motor is rotating at slow speed, e.g., windmilling in fan applications. *2-06 Parking Current* and *2-07 Parking Time* can be adjusted. Increase the factory setting of these parameters for applications with high inertia.

Start the motor at nominal speed. If the application does not run well, check the VVC^{plus} PM settings. Recommendations for different applications can be seen in *Table 5.6*.

Application	Settings
Low inertia applications $I_{Load}/I_{Motor} < 5$	<i>1-17 Voltage Filter Time Const.</i> to be increased by factor 5 to 10 <i>1-14 Damping Gain</i> should be reduced <i>1-66 Min. Current at Low Speed</i> should be reduced (<100%)
Low inertia applications $50 > I_{Load}/I_{Motor} > 5$	Keep calculated values
High inertia applications $I_{Load}/I_{Motor} > 50$	<i>1-14 Damping Gain</i> , <i>1-15 Low Speed Filter Time Const.</i> and <i>1-16 High Speed Filter Time Const.</i> should be increased
High load at low speed <30% (rated speed)	<i>1-17 Voltage Filter Time Const.</i> should be increased <i>1-66 Min. Current at Low Speed</i> should be increased (>100% for a prolonged time can overheat the motor)

Table 5.6 Recommendations for Different Applications

If the motor starts oscillating at a certain speed, increase *1-14 Damping Gain*. Increase the value in small steps. Depending on the motor, a good value for this parameter can be 10% or 100% higher than the default value.

Starting torque can be adjusted in *1-66 Min. Current at Low Speed*. 100% provides nominal torque as starting torque.

5.4.5 Automatic Energy Optimization (AEO)

NOTICE!

AEO is not relevant for permanent magnet motors.

Automatic Energy Optimization (AEO) is a procedure that minimizes voltage to the motor, reducing energy consumption, heat, and noise.

To activate AEO, set parameter *1-03 Torque Characteristics* to [2] *Auto Energy Optim. CT* or [3] *Auto Energy Optim. VT*.

5.4.6 Automatic Motor Adaptation (AMA)

NOTICE!

AMA is not relevant for PM motors.

Automatic motor adaptation (AMA) is a procedure that optimizes compatibility between the adjustable frequency drive and the motor.

- The adjustable frequency drive builds a mathematical model of the motor for regulating output motor current. The procedure also tests the input phase balance of electrical power. It compares the motor characteristics with the data entered in parameters 1-20 to 1-25.
- The motor shaft does not turn and no harm is done to the motor while running the AMA.
- Some motors may be unable to run the complete version of the test. In that case, select [2] *Enable reduced AMA*.
- If an output filter is connected to the motor, select *Enable reduced AMA*.
- If warnings or alarms occur, see *chapter 7.4 List of Warnings and Alarms*.
- Run this procedure on a cold motor for best results.

To run AMA

1. Press [Main Menu] to access parameters.
2. Scroll to parameter group 1-** *Load and Motor* and press [OK].
3. Scroll to parameter group 1-2* *Motor Data* and press [OK].
4. Scroll to 1-29 *Automatic Motor Adaptation (AMA)* and press [OK].
5. Select [1] *Enable complete AMA* and press [OK].
6. Follow the on-screen instructions.
7. The test runs automatically and indicate when it is complete.

5.5 Checking Motor Rotation

NOTICE!

Risk of damage to pumps/compressors caused by motor running in wrong direction. Before running the adjustable frequency drive, check the motor rotation.

The motor runs briefly at 5 Hz or the minimum frequency set in 4-12 *Motor Speed Low Limit [Hz]*.

1. Press [Main Menu].
2. Scroll to 1-28 *Motor Rotation Check* and press [OK].
3. Scroll to [1] *Enable*.

The following text appears: *Note! Motor may run in wrong direction.*

4. Press [OK].
5. Follow the on-screen instructions.

NOTICE!

To change the direction of rotation, remove power to the adjustable frequency drive and wait for power to discharge. Reverse the connection of any two of the three motor wires on the motor or adjustable frequency drive side of the connection.

5.6 Local Control Test

1. Press [Hand On] to provide a local start command to the adjustable frequency drive.
2. Accelerate the adjustable frequency drive by pressing [▲] to full speed. Moving the cursor left of the decimal point provides quicker input changes.
3. Note any acceleration problems.
4. Press [Off]. Note any deceleration problems.

In the event of acceleration or deceleration problems, see *chapter 7.5 Troubleshooting*. See *chapter 7.4 List of Warnings and Alarms* and *chapter 7.4 List of Warnings and Alarms* for resetting the adjustable frequency drive after a trip.

5.7 System Start-up

The procedure in this section requires user-wiring and application programming to be completed. The following procedure is recommended after application set-up is completed.

1. Press [Auto On].
2. Apply an external run command.
3. Adjust the speed reference throughout the speed range.
4. Remove the external run command.
5. Check sound and vibration level of the motor to ensure that the system is working as intended.

If warnings or alarms occur, see or *chapter 7.4 List of Warnings and Alarms*.

6 Application Set-up Examples

The examples in this section are intended as a quick reference for common applications.

- Parameter settings are the regional default values unless otherwise indicated (selected in *0-03 Regional Settings*).
- Parameters associated with the terminals and their settings are shown next to the drawings.
- Where switch settings for analog terminals A53 or A54 are required, these are also shown.

NOTICE!

When the optional Safe Torque Off feature is used, a jumper wire may be required between terminal 12 (or 13) and terminal 37 for the adjustable frequency drive to operate when using factory default programming values.

6

6.1 Application Examples

6.1.1 Compressor

The SmartStart guides the user through the set-up of a refrigeration compressor asking for input data about the compressor and the refrigeration system on which the adjustable frequency drive will be running. All terminology and units used within the SmartStart are common refrigeration type and set up is thus completed in 10-15 easy steps using just two keys of the LCP.

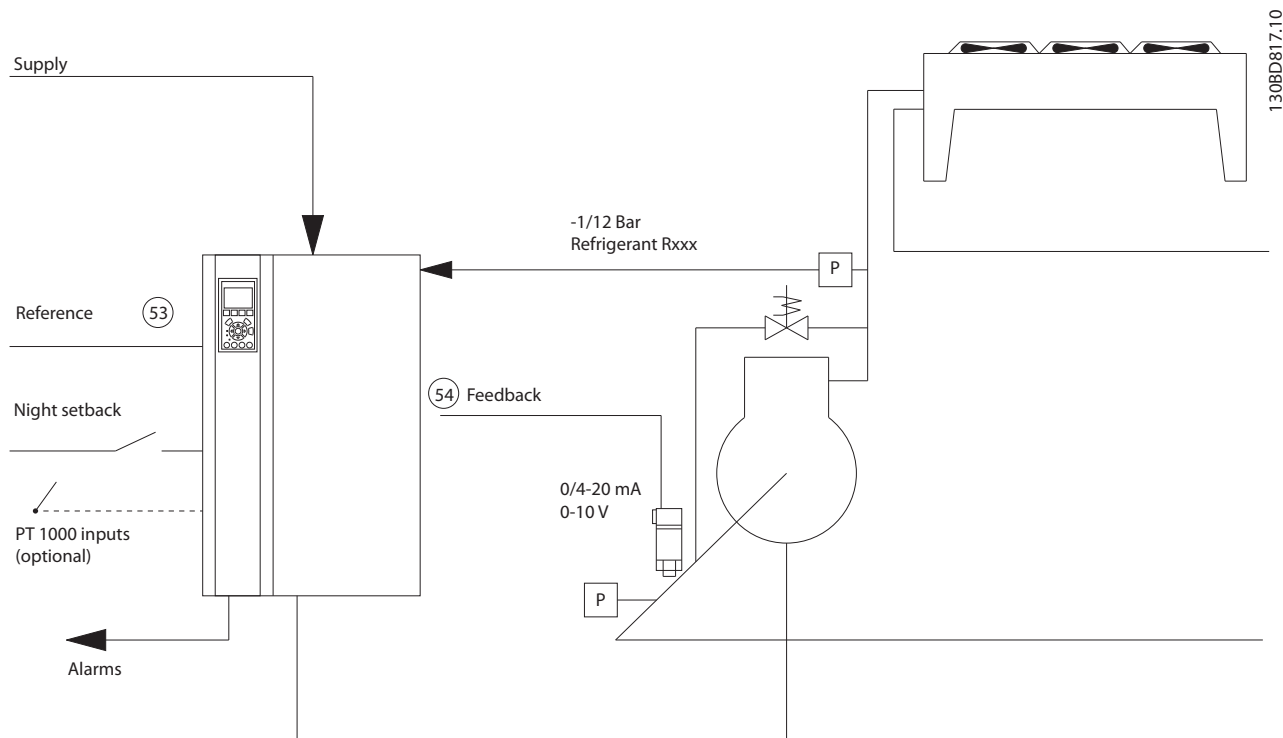

Figure 6.1 Standard Drawing of "Compressor with Internal Control"

SmartStart input:

- Bypass valve
- Recycling time (start to start)
- Min. Hz
- Max. Hz
- Setpoint
- Cut in/cut out
- 400/230 V AC
- Amps
- RPM

6.1.2 Single or Multiple Fans or Pumps

The SmartStart guides through the process of setting up of a refrigeration condenser fan or pump. Enter data about the condenser or pump and the refrigeration system on which the adjustable frequency drive will be running. All terminology and units used within the SmartStart are common refrigeration type and set-up is thus completed in 10-15 easy steps using two keys on the LCP.

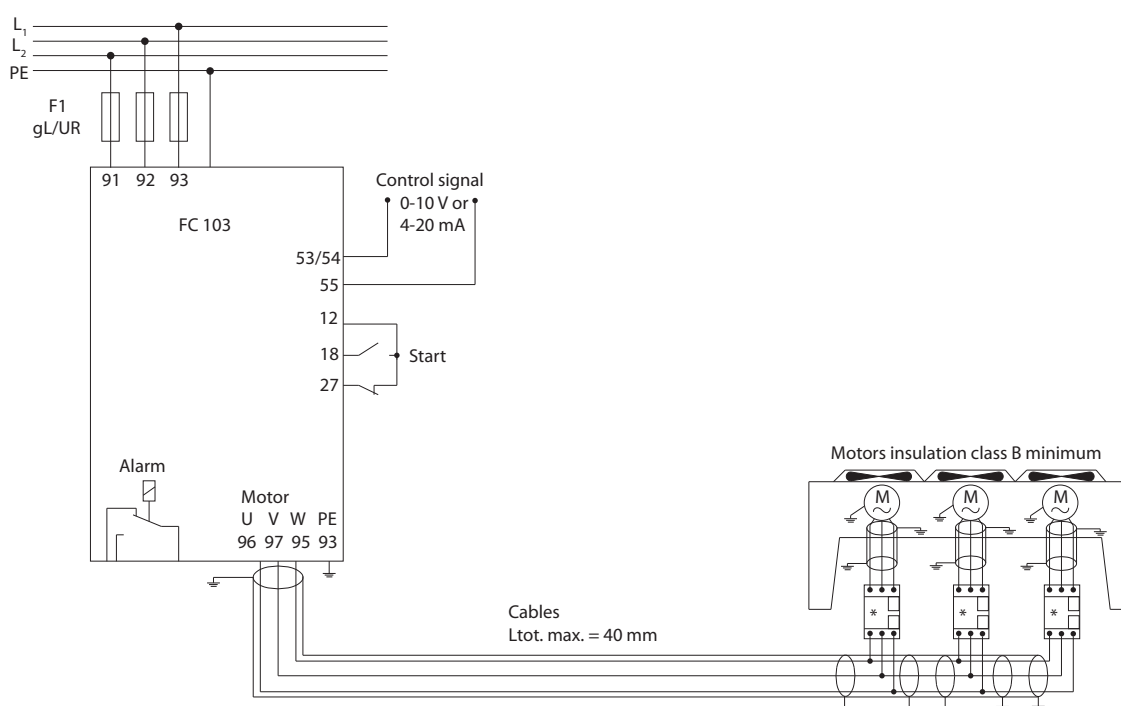

130BD824.10

Figure 6.2 Speed Control Using Analog Reference (Open-loop) – Single Fan or Pump/Multiple Fans or Pumps in Parallel

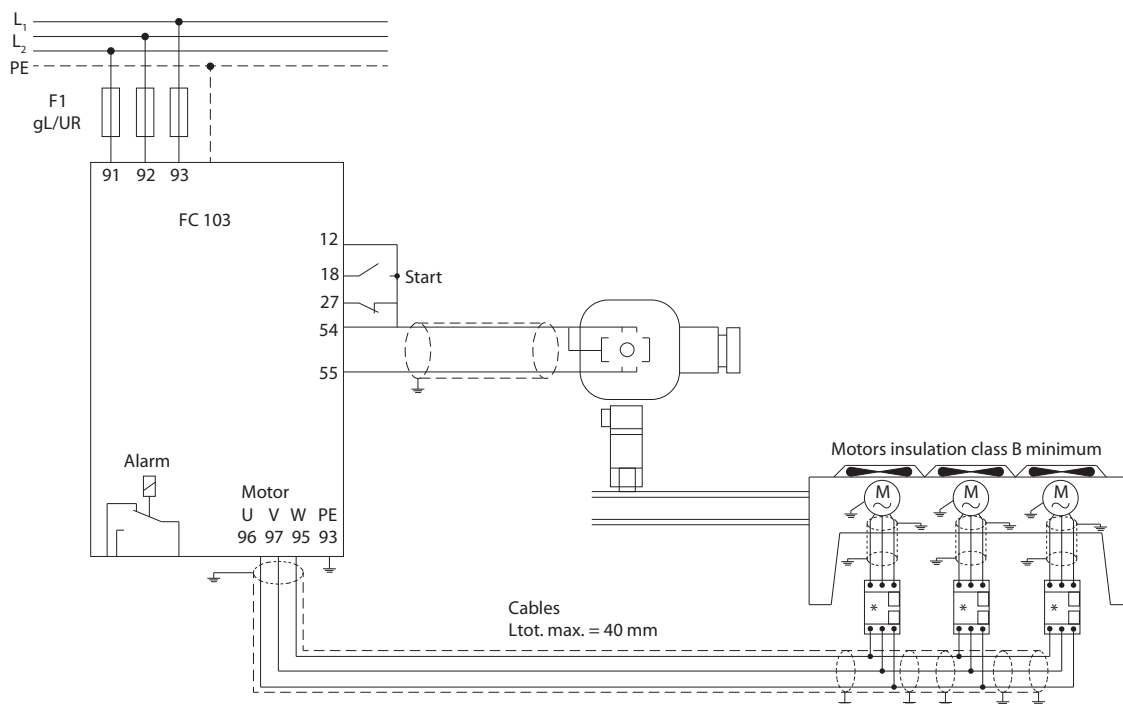

Figure 6.3 Pressure Control in Closed-loop – Stand Alone System – Single Fan or Pump/Multiple Fans or Pumps in Parallel

Recommended motor cable types are:

- LIYCY
- Lapp Oelflex 100CY 450/750 V
- Lapp Oelflex 110CY 600/1000 V
- Lapp Oelflex SERVO 2YSLCY-J9
- Lapp Oelflex SERVO 2YSLCYK-J9
- HELU TOPFLEX-EWV-2YSLCY-J
- HELU TOPFLEX-EWV-UV 2YSLCYK-J
- HELU TOPFLEX-EWV-3PLUS 2YSLCY-J
- HELU TOPFLEX-EWV-UV-3PLUS 2YSLCYK-J
- Faber Kabel EWV-Motorleitung 2YSL(St)Cyy
- nexans MOTIONLINE RHEVFLEX-EWV 2XSLSTCY-J

6.1.3 Compressor Pack

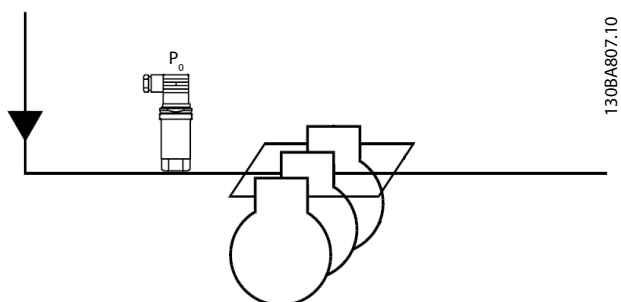

Figure 6.4 P₀ Pressure Transmitter

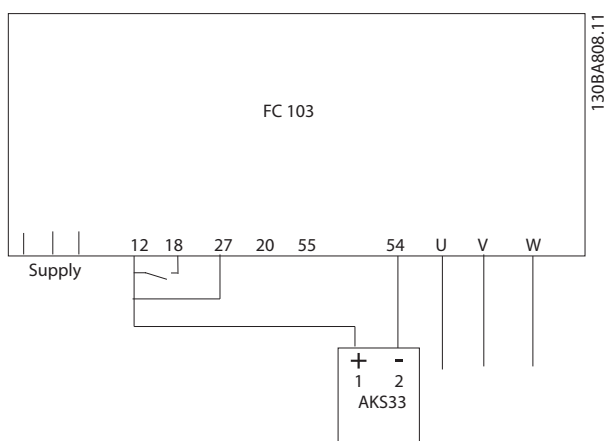

Figure 6.5 How to Connect the FC 103 and AKS33 for Closed-loop Applications

NOTICE!

To find out which parameters are relevant, run the SmartStart.

7 Maintenance, Diagnostics and Troubleshooting

This chapter includes maintenance and service guidelines, status messages, warnings and alarms and basic troubleshooting.

7.1 Maintenance and Service

Under normal operating conditions and load profiles, the adjustable frequency drive is maintenance-free throughout its designed lifetime. To prevent breakdown, danger, and damage, examine the adjustable frequency drive at regular intervals depending on the operating conditions. Replace worn or damaged parts with original spare parts or standard parts. For service and support, refer to www.danfoss.com/contact/sales_and_services/.

⚠ WARNING

HIGH VOLTAGE

Adjustable frequency drives contain high voltage when connected to AC line power. Failure to perform installation, start-up, and maintenance by qualified personnel could result in death or serious injury.

- Installation, start-up, and maintenance must be performed by qualified personnel only.

7.2 Status Messages

When the adjustable frequency drive is in status mode, status messages are generated automatically and appear in the bottom line of the display (see *Figure 7.1*).

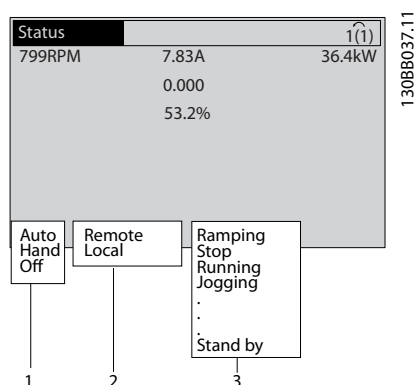

1	Operation mode (see <i>Table 7.1</i>)
2	Reference site (see <i>Table 7.2</i>)
3	Operation status (see <i>Table 7.3</i>)

Figure 7.1 Status Display

Table 7.1 to *Table 7.3* describe the displayed status messages.

Off	The adjustable frequency drive does not react to any control signal until [Auto On] or [Hand On] is pressed.
Auto On	The adjustable frequency drive is controlled from the control terminals and/or the serial communication.
	The adjustable frequency drive is controlled by the navigation keys on the LCP. Stop commands, reset, reversing, DC brake, and other signals applied to the control terminals override local control.

Table 7.1 Operation Mode

Remote	The speed reference is given from external signals, serial communication, or internal preset references.
Local	The adjustable frequency drive uses [Hand On] control or reference values from the LCP.

Table 7.2 Reference Site

AC Brake	AC Brake was selected in <i>2-10 Brake Function</i> . The AC brake overmagnetizes the motor to achieve a controlled slow-down.
AMA finish OK	Automatic motor adaptation (AMA) was carried out successfully.
AMA ready	AMA is ready to start. Press [Hand On] to start.
AMA running	AMA process is in progress.
Coast	<ul style="list-style-type: none"> • Coast inverse was selected as a function for a digital input (parameter group <i>5-1* Digital Inputs</i>). The corresponding terminal is not connected. • Coast activated by serial communication
Ctrl. Ramp-down	Control Ramp-down was selected in <i>14-10 Mains Failure</i> . <ul style="list-style-type: none"> • The AC line voltage is below the value set in <i>14-11 Mains Voltage at Mains Fault</i> at line power fault • The adjustable frequency drive ramps down the motor using a controlled ramp-down.
Current High	The adjustable frequency drive output current is above the limit set in <i>4-51 Warning Current High</i> .

Current Low	The adjustable frequency drive output current is below the limit set in <i>4-52 Warning Speed Low</i> .
DC Hold	DC Hold is selected in <i>1-80 Function at Stop</i> and a stop command is active. The motor is held by a DC current set in <i>2-00 DC Hold/ Preheat Current</i> .
DC Stop	The motor is held with a DC current (<i>2-01 DC Brake Current</i>) for a specified time (<i>2-02 DC Braking Time</i>). <ul style="list-style-type: none"> DC Brake is activated in <i>2-03 DC Brake Cut-in Speed [RPM]</i> and a stop command is active. DC Brake (inverse) is selected as a function for a digital input (parameter group <i>5-1* Digital Inputs</i>). The corresponding terminal is not active. The DC Brake is activated via serial communication.
Feedback high	The sum of all active feedbacks is above the feedback limit set in <i>4-57 Warning Feedback High</i> .
Feedback low	The sum of all active feedbacks is below the feedback limit set in <i>4-56 Warning Feedback Low</i> .
Freeze output	The remote reference is active, which holds the present speed. <ul style="list-style-type: none"> Freeze output was selected as a function for a digital input (parameter group <i>5-1* Digital Inputs</i>). The corresponding terminal is active. Speed control is only possible via the terminal functions Speed Up and Slow. Hold ramp is activated via serial communication.
Freeze output request	A freeze output command was given but the motor remains stopped until a run permissive signal is received.
Freeze ref.	<i>Freeze Reference</i> was selected as a function for a digital input (parameter group <i>5-1* Digital Inputs</i>). The corresponding terminal is active. The adjustable frequency drive saves the actual reference. Changing the reference is now only possible via terminal functions Speed Up and Slow.
Jog request	A jog command was given but the motor remains stopped until a run permissive signal is received via a digital input.

Jogging	The motor is running as programmed in <i>3-19 Jog Speed [RPM]</i> . <ul style="list-style-type: none"> <i>Jog</i> was selected as function for a digital input (parameter group <i>5-1* Digital Inputs</i>). The corresponding terminal (e.g., Terminal 29) is active. The Jog function is activated via the serial communication. The Jog function was selected as a reaction for a monitoring function (e.g., No signal). The monitoring function is active.
Motor check	In <i>1-80 Function at Stop, Motor Check</i> was selected. A stop command is active. To ensure that a motor is connected to the adjustable frequency drive, a permanent test current is applied to the motor.
Over Voltage	<i>Overvoltage control</i> was activated in <i>2-17 Overvoltage Control, [2] Enabled</i> . The connected motor supplies the adjustable frequency drive with generative energy. The overvoltage control adjusts the V/Hz ratio to run the motor in controlled mode and to prevent the adjustable frequency drive from tripping.
PowerUnit Off	(Only adjustable frequency drives with an external 24 V power supply installed). Line power supply to the adjustable frequency drive was removed, and the control card is supplied by the external 24 V.
Protection md	Protection mode is active. The unit has detected a critical status (overcurrent or overvoltage). <ul style="list-style-type: none"> To avoid tripping, switching frequency is reduced to 4 kHz. If possible, protection mode ends after approximately 10 s. Protection mode can be restricted in <i>14-26 Trip Delay at Inverter Fault</i>.
Ramping	The motor is accelerating/decelerating using the active Ramp-Up/Down. The reference, a limit value, or a standstill is not yet reached.
Ref. high	The sum of all active references is above the reference limit set in <i>4-55 Warning Reference High</i> .
Ref. low	The sum of all active references is below the reference limit set in <i>4-54 Warning Reference Low</i> .
Run on ref.	The adjustable frequency drive is running in the reference range. The feedback value matches the setpoint value.
Run request	A start command was given but the motor remains stopped until a run permissive signal is received via digital input.

Running	The motor is driven by the adjustable frequency drive.
Sleep Mode	The energy-saving function is enabled. The motor has stopped but restarts automatically when required.
Speed high	Motor speed is above the value set in 4-53 <i>Warning Speed High</i> .
Speed low	Motor speed is below the value set in 4-52 <i>Warning Speed Low</i> .
Standby	In Auto On mode, the adjustable frequency drive starts the motor with a start signal from a digital input or serial communication.
Start delay	In 1-71 <i>Start Delay</i> , a delay starting time was set. A start command is activated and the motor starts after the start delay time expires.
Start fwd/rev	Start forward and start reverse were selected as functions for two different digital inputs (parameter group 5-1* <i>Digital Inputs</i>). The motor starts in forward or reverse depending on which corresponding terminal is activated.
Stop	The adjustable frequency drive has received a stop command from the LCP, digital input or serial communication.
Trip	An alarm occurred and the motor is stopped. Once the cause of the alarm is cleared, the adjustable frequency drive can be reset manually by pressing [Reset] or remotely by control terminals or serial communication.
Trip lock	An alarm occurred and the motor is stopped. Once the cause of the alarm is cleared, power must be cycled to the adjustable frequency drive. The adjustable frequency drive can then be reset manually by pressing [Reset] or remotely by control terminals or serial communication.

Table 7.3 Operation Status

NOTICE!

In auto/remote mode, the adjustable frequency drive requires external commands to execute functions.

7.3 Warning and Alarm Types

Warnings

A warning is issued when an alarm condition is impending or when an abnormal operating condition is present and may result in the adjustable frequency drive issuing an alarm. A warning clears by itself when the abnormal condition is removed.

Alarms

Trip

An alarm is issued when the adjustable frequency drive is tripped, which means that the adjustable frequency drive suspends operation to prevent adjustable frequency drive or system damage. The motor coasts to a stop. The adjustable frequency drive logic continues to operate and monitor the adjustable frequency drive status. After the fault condition is remedied, the adjustable frequency drive can be reset. It is then ready to start operation again.

Resetting the adjustable frequency drive after trip/trip lock

A trip can be reset in any of four ways:

- Press [Reset] on the LCP
- Digital reset input command
- Serial communication reset input command
- Auto reset

Trip lock

Input power is cycled. The motor coasts to a stop. The adjustable frequency drive continues to monitor the adjustable frequency drive status. Remove input power to the adjustable frequency drive, correct the cause of the fault, and reset the adjustable frequency drive.

Warning and Alarm Displays

- A warning is displayed in the LCP along with the warning number.
- An alarm flashes along with the alarm number.

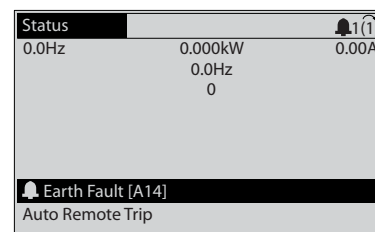

130BP086.11

Figure 7.2 Alarm Display Example

In addition to the text and alarm code in the LCP, there are three status indicator lights.

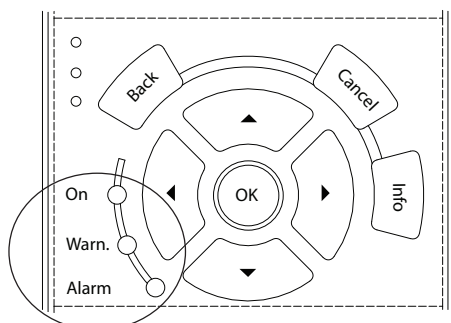

	Warning LED	Alarm LED
Warning	On	Off
Alarm	Off	On (Flashing)
Trip Lock	On	On (Flashing)

Figure 7.3 Status Indicator Lights

7.4 List of Warnings and Alarms

The warning/alarm information below defines each warning/alarm condition, provides the probable cause for the condition, and details a remedy or troubleshooting procedure.

WARNING 1, 10 Volts low

The control card voltage is below 10 V from terminal 50. Remove some of the load from terminal 50, as the 10 V supply is overloaded. Max. 15 mA or minimum 590 Ω.

A short circuit in a connected potentiometer or improper wiring of the potentiometer can cause this condition.

Troubleshooting

- Remove the wiring from terminal 50. If the warning clears, the problem is with the wiring. If the warning does not clear, replace the control card.

WARNING/ALARM 2, Live zero error

This warning or alarm only appears if programmed in 6-01 Live Zero Timeout Function. The signal on one of the analog inputs is less than 50% of the minimum value programmed for that input. Broken wiring or faulty device sending the signal can cause this condition.

Troubleshooting

- Check connections on all the analog input terminals. Control card terminals 53 and 54 for signals, terminal 55 common. MCB 101 terminals 11 and 12 for signals, terminal 10 common. MCB 109 terminals 1, 3, 5 for signals, terminals 2, 4, 6 common.
- Check that the adjustable frequency drive programming and switch settings match the analog signal type.
- Perform input terminal signal test.

WARNING/ALARM 4, Mains phase loss

A phase is missing on the supply side, or the line voltage imbalance is too high. This message also appears for a fault in the input rectifier on the adjustable frequency drive. Options are programmed at 14-12 Function at Mains Imbalance.

Troubleshooting

- Check the supply voltage and supply currents to the adjustable frequency drive.

WARNING 5, DC link voltage high

The intermediate circuit voltage (DC) is higher than the high-voltage warning limit. The limit is dependent on the adjustable frequency drive voltage rating. The unit is still active.

WARNING 6, DC link voltage low

The intermediate circuit voltage (DC) is lower than the low-voltage warning limit. The limit is dependent on the adjustable frequency drive voltage rating. The unit is still active.

WARNING/ALARM 7, DC overvoltage

If the intermediate circuit voltage exceeds the limit, the adjustable frequency drive trips after a time.

Troubleshooting

- Connect a brake resistor
- Extend the ramp time
- Change the ramp type
- Activate the functions in 2-10 Brake Function
- Increase 14-26 Trip Delay at Inverter Fault
- If the alarm/warning occurs during a power sag, use kinetic backup (14-10 Line Failure)

WARNING/ALARM 8, DC undervoltage

If the DC link voltage drops below the undervoltage limit, the adjustable frequency drive checks if a 24 V DC backup supply is connected. If no 24 V DC backup supply is connected, the adjustable frequency drive trips after a fixed time delay. The time delay varies with unit size.

Troubleshooting

- Make sure that the supply voltage matches the adjustable frequency drive voltage.
- Perform input voltage test.
- Perform soft charge circuit test.

WARNING/ALARM 9, Inverter overload

The adjustable frequency drive is about to cut out because of an overload (current too high for too long). The counter for electronic, thermal inverter protection issues a warning at 98% and trips at 100%, while giving an alarm. The adjustable frequency drive cannot be reset until the counter is below 90%.

The fault is that the adjustable frequency drive has run with more than 100% overload for too long.

Troubleshooting

- Compare the output current shown on the LCP with the adjustable frequency drive rated current.
- Compare the output current shown on the LCP with measured motor current.
- Display the thermal drive load on the LCP and monitor the value. When running above the adjustable frequency drive continuous current rating, the counter increases. When running below the adjustable frequency drive continuous current rating, the counter decreases.

WARNING/ALARM 10, Motor overload temperature

According to the electronic thermal protection (ETR), the motor is too hot. Select whether the adjustable frequency drive issues a warning or an alarm when the counter reaches 100% in *1-90 Motor Thermal Protection*. The fault occurs when the motor runs with more than 100% overload for too long.

Troubleshooting

- Check for motor overheating.
- Check if the motor is mechanically overloaded
- Check that the motor current set in 1-24 Motor Current is correct.
- Ensure that Motor data in parameters 1-20 to 1-25 are set correctly.
- If an external fan is in use, check in *1-91 Motor External Fan* that it is selected.
- Running AMA in *1-29 Automatic Motor Adaptation (AMA)* tunes the adjustable frequency drive to the motor more accurately and reduces thermal loading.

WARNING/ALARM 11, Motor thermistor over-temp

Check whether the thermistor is disconnected. Select whether the adjustable frequency drive issues a warning or an alarm in *1-90 Motor Thermal Protection*.

Troubleshooting

- Check for motor overheating.
- Check if the motor is mechanically overloaded.
- When using terminal 53 or 54, check that the thermistor is connected correctly between either terminal 53 or 54 (analog voltage input) and terminal 50 (+10 V supply). Also check that the terminal switch for 53 or 54 is set for voltage. Check *1-93 Thermistor Source* selects terminal 53 or 54.
- When using digital inputs 18 or 19, check that the thermistor is connected correctly between either terminal 18 or 19 (digital input PNP only) and terminal 50. Check *1-93 Thermistor Source* selects terminal 12 to 18, 19, 32 or 33.

WARNING/ALARM 12, Torque limit

The torque has exceeded the value in *4-16 Torque Limit Motor Mode* or the value in *4-17 Torque Limit Generator Mode*. *14-25 Trip Delay at Torque Limit* can change this warning from a warning-only condition to a warning followed by an alarm.

Troubleshooting

- If the motor torque limit is exceeded during ramp-up, extend the ramp-up time.
- If the generator torque limit is exceeded during ramp-down, extend the ramp-down time.
- If torque limit occurs while running, possibly increase the torque limit. Make sure that the system can operate safely at a higher torque.
- Check the application for excessive current draw on the motor.

WARNING/ALARM 13, Overcurrent

The inverter peak current limit (approximately 200% of the rated current) is exceeded. The warning lasts about 1.5 s, then the adjustable frequency drive trips and issues an alarm. Shock loading or quick acceleration with high inertia loads can cause this fault. If the acceleration during ramp up is quick, the fault can also appear after kinetic backup. If extended mechanical brake control is selected, trip can be reset externally.

Troubleshooting

- Remove power and check if the motor shaft can be turned.
- Make sure that the motor size matches the adjustable frequency drive.
- Check parameters 1-20 to 1-25 for correct motor data.

ALARM 14, Ground fault

There is current from the output phases to ground, either in the cable between the adjustable frequency drive and the motor or in the motor itself.

Troubleshooting

- Remove power to the adjustable frequency drive and repair the ground fault.
- Check for ground faults in the motor by measuring the resistance to ground of the motor leads and the motor with a megohmmeter.

ALARM 15, Hardware mismatch

A fitted option is not operational with the present control board hardware or software.

Record the value of the following parameters and contact Danfoss:

- 15-40 FC Type
- 15-41 Power Section
- 15-42 Voltage
- 15-43 Software Version
- 15-45 Actual Typecode String
- 15-49 SW ID Control Card
- 15-50 SW ID Power Card
- 15-60 Option Mounted
- 15-61 Option SW Version (for each option slot)

ALARM 16, Short-circuit

There is short-circuiting in the motor or motor wiring.

Remove power to the adjustable frequency drive and repair the short circuit.

WARNING/ALARM 17, Control word timeout

There is no communication to the adjustable frequency drive.

The warning is only active when *8-04 Control Word Timeout Function* is NOT set to [0] Off.

If *8-04 Control Word Timeout Function* is set to [5] Stop and Trip, a warning appears and the adjustable frequency drive ramps down until it stops then displays an alarm.

Troubleshooting

- Check connections on the serial communication cable.
- Increase *8-03 Control Word Timeout Time*
- Check the operation of the communication equipment.
- Verify a proper installation based on EMC requirements.

ALARM 18, Start failed

The speed has not been able to exceed *1-77 Compressor Start Max Speed [RPM]* during start within the allowed time. (set in *1-79 Compressor Start Max Time to Trip*). This may be caused by a blocked motor.

WARNING 23, Internal fan fault

The fan warning function is an extra protective function that checks if the fan is running/mounted. The fan warning can be disabled in *14-53 Fan Monitor ([0] Disabled)*.

For the D, E, and F-frame filters, the regulated voltage to the fans is monitored.

Troubleshooting

- Check for proper fan operation.
- Cycle power to the adjustable frequency drive and check that the fan operates briefly at start-up.
- Check the sensors on the heatsink and control card.

WARNING 24, External fan fault

The fan warning function is an extra protective function that checks if the fan is running/mounted. The fan warning can be disabled in *14-53 Fan Monitor ([0] Disabled)*.

Troubleshooting

- Check for proper fan operation.
- Cycle power to the adjustable frequency drive and check that the fan operates briefly at start-up.
- Check the sensors on the heatsink and control card.

ALARM 29, Heatsink temp

The maximum temperature of the heatsink has been exceeded. The temperature fault does not reset until the temperature falls below a defined heatsink temperature. The trip and reset points are different based on the adjustable frequency drive power size.

Troubleshooting

Check for the following conditions.

- Ambient temperature too high.
- Motor cable too long.
- Incorrect airflow clearance above and below the adjustable frequency drive.
- Blocked airflow around the adjustable frequency drive.
- Damaged heatsink fan.
- Dirty heatsink.

ALARM 30, Motor phase U missing

Motor phase U between the adjustable frequency drive and the motor is missing.

Remove power from the adjustable frequency drive and check motor phase U.

ALARM 31, Motor phase V missing

Motor phase V between the adjustable frequency drive and the motor is missing.

Remove power from the adjustable frequency drive and check motor phase V.

ALARM 32, Motor phase W missing

Motor phase W between the adjustable frequency drive and the motor is missing.

Remove power from the adjustable frequency drive and check motor phase W.

ALARM 33, Inrush fault

Too many power-ups have occurred within a short time period. Let the unit cool to operating temperature.

WARNING/ALARM 34, Fieldbus communication fault

The serial communication bus on the communication option card is not working.

WARNING/ALARM 36, Mains failure

This warning/alarm is only active if the supply voltage to the adjustable frequency drive is lost and *14-10 Mains Failure* is not set to [0] *No Function*. Check the fuses to the adjustable frequency drive and line power supply to the unit.

ALARM 38, Internal fault

When an internal fault occurs, a code number defined in *Table 7.4* is displayed.

Troubleshooting

- Cycle power
- Check that the option is properly installed
- Check for loose or missing wiring

It may be necessary to contact your Danfoss supplier or service department. Note the code number for further troubleshooting directions.

No.	Text
0	Serial port cannot be initialized. Contact your Danfoss supplier or Danfoss Service Department.
256-258	Power EEPROM data is defective or too old. Replace power card.
512-519	Internal fault. Contact your Danfoss supplier or Danfoss Service Department.
783	Parameter value outside of min/max limits
1024-1284	Internal fault. Contact your Danfoss supplier or the Danfoss Service Department.
1299	Option SW in slot A is too old.
1300	Option SW in slot B is too old.
1315	Option SW in slot A is not supported (not allowed).
1316	Option SW in slot B is not supported (not allowed).
1379-2819	Internal fault. Contact your Danfoss supplier or Danfoss Service Department.
1792	HW reset of DSP.
1793	Motor-derived parameters not transferred correctly to DSP.
1794	Power data not transferred correctly at power-up to DSP.
1795	The DSP has received too many unknown SPI messages.
1796	RAM copy error.
2561	Replace control card.
2820	LCP stack overflow.
2821	Serial port overflow.
2822	USB port overflow.
3072-5122	Parameter value is outside its limits.
5123	Option in slot A: Hardware incompatible with control board hardware.
5124	Option in slot B: Hardware incompatible with control board hardware.
5376-6231	Internal fault. Contact your Danfoss supplier or Danfoss Service Department.

Table 7.4 Internal Fault Codes

ALARM 39, Heatsink sensor

No feedback from the heatsink temperature sensor.

The signal from the IGBT thermal sensor is not available on the power card. The problem could be on the power card, on the gate drive card, or the ribbon cable between the power card and gate drive card.

WARNING 40, Overload of digital output terminal 27

Check the load connected to terminal 27 or remove short-circuit connection. Check *5-00 Digital I/O Mode* and *5-01 Terminal 27 Mode*.

WARNING 41, Overload of digital output terminal 29

Check the load connected to terminal 29 or remove short-circuit connection. Check *5-00 Digital I/O Mode* and *5-02 Terminal 29 Mode*.

WARNING 42, Overload of digital output on X30/6 or overload of digital output on X30/7

For X30/6, check the load connected to X30/6 or remove the short-circuit connection. Check *5-32 Term X30/6 Digi Out (MCB 101)*.

For X30/7, check the load connected to X30/7 or remove the short-circuit connection. Check *5-33 Term X30/7 Digi Out (MCB 101)*.

ALARM 45, Ground fault 2

Ground fault.

Troubleshooting

- Check for proper grounding and loose connections.
- Check for proper wire size.
- Check motor cables for short-circuits or leakage currents.

ALARM 46, Power card supply

The supply on the power card is out of range.

There are three power supplies generated by the switch mode power supply (SMPS) on the power card: 24 V, 5 V, ± 18 V. When powered with 24 V DC with the MCB 107 option, only the 24 V and 5 V supplies are monitored. When powered with three-phase AC line voltage, all three supplies are monitored.

Troubleshooting

- Check for a defective power card.
- Check for a defective control card.
- Check for a defective option card.
- If a 24 V DC power supply is used, verify proper supply power.

WARNING 47, 24 V supply low

The 24 V DC is measured on the control card. This alarm arises when the detected voltage of terminal 12 is lower than 18 V.

Troubleshooting

- Check for a defective control card.

WARNING 48, 1.8 V supply low

The 1.8 V DC supply used on the control card is outside of allowable limits. The power supply is measured on the control card. Check for a defective control card. If an option card is present, check for an overvoltage condition.

WARNING 49, Speed limit

When the speed is not within the specified range in *4-11 Motor Speed Low Limit [RPM]* and *4-13 Motor Speed High Limit [RPM]*, the adjustable frequency drive shows a warning. When the speed is below the specified limit in *1-86 Trip Speed Low [RPM]* (except when starting or stopping), the adjustable frequency drive trips.

ALARM 50, AMA calibration failed

Contact Danfoss supplier or Danfoss service department.

ALARM 51, AMA check U_{nom} and I_{nom}

The settings for motor voltage, motor current and motor power are wrong. Check the settings in parameters 1-20 to 1-25.

ALARM 52, AMA low I_{nom}

The motor current is too low. Check the settings.

ALARM 53, AMA motor too big

The motor is too big for the AMA to operate.

ALARM 54, AMA motor too small

The motor is too small for the AMA to operate.

ALARM 55, AMA parameter out of range

The parameter values of the motor are outside of the acceptable range. AMA cannot run.

ALARM 56, AMA interrupted by user

The user has interrupted the AMA.

ALARM 57, AMA internal fault

Try to restart AMA again. Repeated restarts can overheat the motor.

ALARM 58, AMA Internal fault

Contact the Danfoss supplier.

WARNING 59, Current limit

The current is higher than the value in *4-18 Current Limit*. Ensure that motor data in parameters 1–20 to 1–25 are set correctly. Possibly increase the current limit. Be sure that the system can operate safely at a higher limit.

WARNING 60, External interlock

A digital input signal is indicating a fault condition external to the adjustable frequency drive. An external interlock has commanded the adjustable frequency drive to trip. Clear the external fault condition. To resume normal operation, apply 24 V DC to the terminal programmed for external interlock. Reset the adjustable frequency drive.

WARNING 62, Output frequency at maximum limit

The output frequency has reached the value set in *4-19 Max Output Frequency*. Check the application to determine the cause. Possibly increase the output frequency limit. Be sure the system can operate safely at a higher output frequency. The warning clears when the output drops below the maximum limit.

WARNING/ALARM 65, Control card overtemperature

The cut-out temperature of the control card is 176 °F [80 °C].

Troubleshooting

- Check that the ambient operating temperature is within limits.
- Check for clogged filters.
- Check fan operation.
- Check the control card.

WARNING 66, Heatsink temperature low

The adjustable frequency drive is too cold to operate. This warning is based on the temperature sensor in the IGBT module.

Increase the ambient temperature of the unit. Also, a trickle amount of current can be supplied to the adjustable frequency drive whenever the motor is stopped by setting *2-00 DC Hold/Preheat Current* at 5% and *1-80 Function at Stop*.

ALARM 67, Option module configuration has changed

One or more options have either been added or removed since the last power-down. Check that the configuration change is intentional and reset the unit.

ALARM 68, Safe Stop activated

Safe Torque Off has been activated. To resume normal operation, apply 24 V DC to terminal 37, then send a reset signal (via bus, digital I/O, or by pressing [Reset]).

ALARM 69, Power card temperature

The temperature sensor on the power card is either too hot or too cold.

Troubleshooting

- Check that the ambient operating temperature is within limits.
- Check for clogged filters.
- Check fan operation.
- Check the power card.

ALARM 70, Illegal FC configuration

The control card and power card are incompatible. To check compatibility, contact the Danfoss supplier with the type code of the unit from the nameplate and the part numbers of the cards.

ALARM 80, Drive initialized to default value

Parameter settings are initialized to default settings after a manual reset. To clear the alarm, reset the unit.

ALARM 92, No-Flow

A no-flow condition has been detected in the system. *22-23 No-Flow Function* is set for alarm. Troubleshoot the system and reset the adjustable frequency drive after the fault has been cleared.

ALARM 93, Dry pump

A no-flow condition in the system with the adjustable frequency drive operating at high speed may indicate a dry pump. *22-26 Dry Pump Function* is set for alarm. Troubleshoot the system and reset the adjustable frequency drive after the fault has been cleared.

ALARM 94, End of curve

Feedback is lower than the setpoint. This may indicate leakage in the system. *22-50 End of Curve Function* is set for alarm. Troubleshoot the system and reset the adjustable frequency drive after the fault has been cleared.

ALARM 95, Broken belt

Torque is below the torque level set for no load, indicating a broken belt. *22-60 Broken Belt Function* is set for alarm. Troubleshoot the system and reset the adjustable frequency drive after the fault has been cleared.

ALARM 96, Start delayed

Motor start has been delayed due to short-cycle protection. *22-76 Interval between Starts* is enabled. Troubleshoot the system and reset the adjustable frequency drive after the fault has been cleared.

WARNING 97, Stop delayed

Stopping the motor has been delayed due to short cycle protection. *22-76 Interval between Starts* is enabled. Troubleshoot the system and reset the adjustable frequency drive after the fault has been cleared.

WARNING 98, Clock fault

Time is not set or the RTC clock has failed. Reset the clock in *0-70 Date and Time*.

WARNING 203, Missing motor

With an adjustable frequency drive operating multi-motors, an underload condition was detected. This could indicate a missing motor. Inspect the system for proper operation.

WARNING 204, Locked rotor

With an adjustable frequency drive operating multi-motors, an overload condition was detected. This could indicate a locked rotor. Inspect the motor for proper operation.

WARNING 250, New spare part

A component in the adjustable frequency drive has been replaced. Reset the adjustable frequency drive for normal operation.

WARNING 251, New type code

The power card or other components have been replaced and the type code changed. Reset to remove the warning and resume normal operation.

7.5 Troubleshooting

Symptom	Possible cause	Test	Solution
Display dark/No function	Missing input power	See <i>Table 4.3</i>	Check the input power source.
	Missing or open fuses or circuit breaker tripped	See open fuses and tripped circuit breaker in this table for possible causes.	Follow the recommendations provided.
	No power to the LCP	Check the LCP cable for proper connection or damage.	Replace the faulty LCP or connection cable.
	Shortcut on control voltage (terminal 12 or 50) or at control terminals	Check the 24 V control voltage supply for terminals 12/13 to 20-39 or 10 V supply for terminals 50 to 55.	Wire the terminals properly.
	Incompatible LCP (LCP from VLT® 2800 or 5000/6000/8000/FCD or FCM)		Use only LCP 102 (P/N 130B1107).
	Wrong contrast setting		Press [Status] + [▲]/[▼] to adjust the contrast.
	Display (LCP) is defective	Test using a different LCP.	Replace the faulty LCP or connection cable.
	Internal voltage supply fault or SMPS is defective		Contact supplier.
Intermittent display	Overloaded power supply (SMPS) due to improper control wiring or a fault within the adjustable frequency drive	To rule out a problem in the control wiring, disconnect all control wiring by removing the terminal blocks.	If the display stays lit, then the problem is in the control wiring. Check the wiring for short circuits or incorrect connections. If the display continues to cut out, follow the procedure for display dark.
Motor not running	Service switch open or missing motor connection	Check if the motor is connected and the connection is not interrupted (by a service switch or other device).	Connect the motor and check the service switch.
	No line power with 24 V DC option card	If the display is functioning but no output, check that line power is applied to the adjustable frequency drive.	Apply line power to run the unit.
	LCP Stop	Check if [Off] has been pressed.	Press [Auto On] or [Hand On] (depending on operation mode) to run the motor.
	Missing start signal (Standby)	Check <i>5-10 Terminal 18 Digital Input</i> for correct setting for terminal 18 (use default setting).	Apply a valid start signal to start the motor.
	Motor coast signal active (Coasting)	Check <i>5-12 Coast inv.</i> for correct setting for terminal 27 (use default setting).	Apply 24 V on terminal 27 or program this terminal to <i>No operation</i> .
	Wrong reference signal source	Check reference signal: Local, remote or bus reference? Preset reference active? Terminal connection correct? Scaling of terminals correct? Reference signal available?	Program correct settings. Check <i>3-13 Reference Site</i> . Set preset reference active in parameter group <i>3-1* References</i> . Check for correct wiring. Check scaling of terminals. Check reference signal.
Motor running in wrong direction	Motor rotation limit	Check that <i>4-10 Motor Speed Direction</i> is programmed correctly.	Program correct settings.
	Active reversing signal	Check if a reversing command is programmed for the terminal in parameter group <i>5-1* Digital inputs</i> .	Deactivate reversing signal.
	Wrong motor phase connection		See <i>chapter 5.5 Checking Motor Rotation</i> .

Symptom	Possible cause	Test	Solution
Motor is not reaching maximum speed	Frequency limits set wrong	Check output limits in 4-13 <i>Motor Speed High Limit [RPM]</i> , 4-14 <i>Motor Speed High Limit [Hz]</i> and 4-19 <i>Max Output Frequency</i> .	Program correct limits.
	Reference input signal not scaled correctly	Check reference input signal scaling in 6-0* <i>Analog I/O Mode</i> and parameter group 3-1* <i>References</i> . Reference limits in parameter group 3-0* <i>Reference Limits</i> .	Program correct settings.
Motor speed unstable	Possible incorrect parameter settings	Check the settings of all motor parameters, including all motor compensation settings. For closed-loop operation, check PID settings.	Check settings in parameter group 1-6* <i>Load Depen.Setting</i> . For closed-loop operation, check settings in parameter group 20-0* <i>Feedback</i> .
Motor runs rough	Possible overmagnetization	Check for incorrect motor settings in all motor parameters.	Check motor settings in parameter groups 1-2* <i>Motor Data</i> , 1-3* <i>Addl. Motor Data</i> , and 1-5* <i>Load Indep. Setting</i> .
Motor will not brake	Possible incorrect settings in the brake parameters. Possible too short ramp-down times	Check brake parameters. Check ramp time settings.	Check parameter group 2-0* <i>DC Brake</i> and 3-0* <i>Reference Limits</i> .
Open power fuses or circuit breaker trip	Phase-to-phase short	Motor or panel has a short phase-to-phase. Check motor and panel phase for shorts.	Eliminate any short circuits detected.
	Motor overload	Motor is overloaded for the application.	Perform start-up test and verify motor current is within specifications. If motor current is exceeding nameplate full load current, motor may run only with reduced load. Review the specifications for the application.
	Loose connections	Perform pre-start-up check for loose connections	Tighten loose connections.
Line power current imbalance greater than 3%	Problem with line power (See <i>Alarm 4 Mains phase loss</i> description)	Rotate input power leads into the adjustable frequency drive one position: A to B, B to C, C to A.	If imbalanced leg follows the wire, it is a power problem. Check line power supply.
	Problem with the adjustable frequency drive	Rotate input power leads into the adjustable frequency drive one position: A to B, B to C, C to A.	If imbalance leg stays on same input terminal, it is a problem with the unit. Contact the supplier.
Motor current imbalance greater than 3%	Problem with motor or motor wiring	Rotate output motor leads one position: U to V, V to W, W to U.	If imbalanced leg follows the wire, the problem is in the motor or motor wiring. Check motor and motor wiring.
	Problem with the adjustable frequency drives	Rotate output motor leads one position: U to V, V to W, W to U.	If imbalance leg stays on same output terminal, it is a problem with the unit. Contact the supplier.
Adjustable frequency drive acceleration problems	Motor data are entered incorrectly	If warnings or alarms occur, see <i>chapter 7.4 List of Warnings and Alarms</i> . Check that motor data are entered correctly	Increase the ramp-up time in 3-41 <i>Ramp 1 Ramp-up Time</i> . Increase ramp 3-80 <i>Jog</i> and 3-82 <i>Starting ramp-up time</i> . Increase current limit in 4-18 <i>Current Limit</i> . Increase torque limit in 4-16 <i>Torque Limit Motor Mode</i> .
Adjustable frequency drive deceleration problems	Motor data are entered incorrectly	If warnings or alarms occur, see <i>chapter 7.4 List of Warnings and Alarms</i> . Check that motor data are entered correctly	Increase the ramp-down time in 3-42 <i>Ramp 1 Ramp-down Time</i> . Enable overvoltage control in 2-17 <i>Over-voltage Control</i> .

Symptom	Possible cause	Test	Solution
Acoustic noise or vibration (e.g., a fan blade is making noise or vibrations at certain frequencies)	Resonances, e.g., in the motor/fan system	Bypass critical frequencies by using parameters in parameter group 4-6* <i>Speed Bypass</i> .	Check if noise and/or vibration have been reduced to an acceptable limit.
		Turn off overmodulation in 14-03 <i>Overmodulation</i> .	
		Change switching pattern and frequency in parameter group 14-0* <i>Inverter Switching</i> .	
		Increase Resonance Dampening in 1-64 <i>Resonance Dampening</i> .	

Table 7.5 Troubleshooting

8 Specifications

8.1 Electrical Data

8.1.1 Line Power Supply 3x200–240 V AC

Type Designation	P1K1	P1K5	P2K2	P3K0	P3K7
Typical Shaft Output [kW]	1.1	1.5	2.2	3.0	3.7
Typical Shaft Output [HP] at 208 V	1.5	2.0	2.9	4.0	4.9
IP20/Chassis ⁶⁾	A2	A2	A2	A3	A3
IP55/Type 12	A4/A5	A4/A5	A4/A5	A5	A5
IP66/NEMA 4X	A4/A5	A4/A5	A4/A5	A5	A5
Output current					
Continuous (3x200–240 V) [A]	6.6	7.5	10.6	12.5	16.7
Intermittent (3x200–240 V) [A]	7.3	8.3	11.7	13.8	18.4
Continuous kVA (208 V AC) [kVA]	2.38	2.70	3.82	4.50	6.00
Max. input current					
Continuous (3x200–240 V) [A]	5.9	6.8	9.5	11.3	15.0
Intermittent (3x200–240 V) [A]	6.5	7.5	10.5	12.4	16.5
Additional specifications					
Estimated power loss at rated max. load [W] ⁴⁾	63	82	116	155	185
IP20, IP21 max. cable cross-section (line power, motor, brake and load sharing) [mm ² /(AWG)]	4, 4, 4 (12, 12, 12) (min. 0.2 (24))				
IP55, IP66 max. cable cross-section (line power, motor, brake and load sharing) [mm ² /(AWG)]	4, 4, 4 (12, 12, 12)				
Max. cable cross-section with disconnect	6, 4, 4 (10, 12, 12)				
Efficiency ³⁾	0.96	0.96	0.96	0.96	0.96

Table 8.1 Line Power Supply 3x200–240 V AC - Normal overload 110% for 1 minute, P1K1-P3K7

Type Designation	P5K5	P7K5	P11K	P15K	P18K	P22K	P30K	P37K	P45K
Typical Shaft Output [kW]	5.5	7.5	11	15	18.5	22	30	37	45
Typical Shaft Output [HP] at 208 V	7.5	10	15	20	25	30	40	50	60
IP20/Chassis ⁷⁾	B3	B3	B3	B4	B4	C3	C3	C4	C4
IP21/NEMA 1	B1	B1	B1	B2	C1	C1	C1	C2	C2
IP55/Type 12	B1	B1	B1	B2	C1	C1	C1	C2	C2
IP66/NEMA 4X	B1	B1	B1	B2	C1	C1	C1	C2	C2
Output current									
Continuous (3x200–240 V) [A]	24.2	30.8	46.2	59.4	74.8	88.0	115	143	170
Intermittent (3x200–240 V) [A]	26.6	33.9	50.8	65.3	82.3	96.8	127	157	187
Continuous kVA (208 V AC) [kVA]	8.7	11.1	16.6	21.4	26.9	31.7	41.4	51.5	61.2
Max. input current									
Continuous (3x200–240 V) [A]	22.0	28.0	42.0	54.0	68.0	80.0	104.0	130.0	154.0
Intermittent (3x200–240 V) [A]	24.2	30.8	46.2	59.4	74.8	88.0	114.0	143.0	169.0
Additional Specifications									
Estimated power loss at rated max. load [W] ⁴⁾	269	310	447	602	737	845	1140	1353	1636
IP20 max. cable cross-section (line power, brake, motor and load sharing) [mm ² /(AWG)]	10, 10 (8,8,-)		35 _{r-r} (2 _{r-r} -)	35 (2)	50 (1)			150 (300 MCM)	
IP21, IP55, IP66 max. cable cross-section (line power, motor) [mm ² /(AWG)]	10, 10 (8,8,-)		35, 25, 25 (2, 4, 4)		50 (1)			150 (300 MCM)	
IP21, IP55, IP66 max. cable cross-section (brake, load sharing) [mm ² /(AWG)]	16, 10, 16 (6, 8, 6)		35 _{r-r} (2 _{r-r} -)		50 (1)			95 (3/0)	
Efficiency ³⁾	0.96	0.96	0.96	0.96	0.96	0.97	0.97	0.97	0.97

Table 8.2 Line Power Supply 3x200–240 V AC - Normal overload 110% for 1 minute, P5K5-P45K

8.1.2 Line Power Supply 3x380–480 V AC

Type Designation	P1K1	P1K5	P2K2	P3K0	P4K0	P5K5	P7K5
Typical Shaft Output [kW]	1.1	1.5	2.2	3.0	4.0	5.5	7.5
Typical Shaft Output [HP] at 460 V	1.5	2.0	2.9	4.0	5.0	7.5	10
IP20/Chassis ⁶⁾	A2	A2	A2	A2	A2	A3	A3
IP55/Type 12	A4/A5	A4/A5	A4/A5	A4/A5	A4/A5	A5	A5
IP66/NEMA 4X	A4/A5	A4/A5	A4/A5	A4/A5	A4/A5	A5	A5
Output current							
Continuous (3x380–440 V) [A]	3	4.1	5.6	7.2	10	13	16
Intermittent (3x380–440 V) [A]	3.3	4.5	6.2	7.9	11	14.3	17.6
Continuous (3x441–480 V) [A]	2.7	3.4	4.8	6.3	8.2	11	14.5
Intermittent (3x441–480 V) [A]	3.0	3.7	5.3	6.9	9.0	12.1	15.4
Continuous kVA (400 V AC) [kVA]	2.1	2.8	3.9	5.0	6.9	9.0	11.0
Continuous kVA (460 V AC) [kVA]	2.4	2.7	3.8	5.0	6.5	8.8	11.6
Max. input current							
Continuous (3x380–440 V) [A]	2.7	3.7	5.0	6.5	9.0	11.7	14.4
Intermittent (3x380–440 V) [A]	3.0	4.1	5.5	7.2	9.9	12.9	15.8
Continuous (3x441–480 V) [A]	2.7	3.1	4.3	5.7	7.4	9.9	13.0
Intermittent (3x441–480 V) [A]	3.0	3.4	4.7	6.3	8.1	10.9	14.3
Additional specifications							
Estimated power loss at rated max. load [W] ⁴⁾	58	62	88	116	124	187	255
IP20, IP21 max. cable cross-section (line power, motor, brake and load sharing) [mm ² /(AWG)] ²⁾	4, 4, 4 (12, 12, 12) (min. 0.2 (24))						
IP55, IP66 max. cable cross-section (line power, motor, brake and load sharing) [mm ² /(AWG)] ²⁾	4, 4, 4 (12, 12, 12)						
Max. cable cross-section with disconnect	6, 4, 4 (10, 12, 12)						
Efficiency ³⁾	0.96	0.97	0.97	0.97	0.97	0.97	0.97

Table 8.3 Line Power Supply 3x380–480 V AC - Normal overload 110% for 1 minute, P1K1-P7K5

Type Designation	P11K	P15K	P18K	P22K	P30K	P37K	P45K	P55K	P75K	P90K
Typical Shaft Output [kW]	11	15	18.5	22	30	37	45	55	75	90
Typical Shaft Output [HP] at 460 V	15	20	25	30	40	50	60	75	100	125
IP20/Chassis ⁷⁾	B3	B3	B3	B4	B4	B4	C3	C3	C4	C4
IP21/NEMA 1	B1	B1	B1	B2	B2	C1	C1	C1	C2	C2
IP55/Type 12	B1	B1	B1	B2	B2	C1	C1	C1	C2	C2
IP66/NEMA 4X	B1	B1	B1	B2	B2	C1	C1	C1	C2	C2
Output current										
Continuous (3x380-439 V) [A]	24	32	37.5	44	61	73	90	106	147	177
Intermittent (3x380-439 V) [A]	26.4	35.2	41.3	48.4	67.1	80.3	99	117	162	195
Continuous (3x440-480 V) [A]	21	27	34	40	52	65	80	105	130	160
Intermittent (3x440-480 V) [A]	23.1	29.7	37.4	44	61.6	71.5	88	116	143	176
Continuous kVA (400 V AC) [kVA]	16.6	22.2	26	30.5	42.3	50.6	62.4	73.4	102	123
Continuous kVA (460 V AC) [kVA]	16.7	21.5	27.1	31.9	41.4	51.8	63.7	83.7	104	128
Max. input current										
Continuous (3x380-439 V) [A]	22	29	34	40	55	66	82	96	133	161
Intermittent (3x380-439 V) [A]	24.2	31.9	37.4	44	60.5	72.6	90.2	106	146	177
Continuous (3x440-480 V) [A]	19	25	31	36	47	59	73	95	118	145
Intermittent (3x440-480 V) [A]	20.9	27.5	34.1	39.6	51.7	64.9	80.3	105	130	160
Additional specifications										
Estimated power loss at rated max. load [W] ⁴⁾	278	392	465	525	698	739	843	1083	1384	1474
IP20 max. cable cross-section (line power, brake, motor and load sharing) [mm ² /(AWG)]	16, 10, - (8, 8, -)		35, -, - (2, -, -)		35 (2)	50 (1)			150 (300 MCM)	
IP21, IP55, IP66 max. cable cross-section (line power, motor) [mm ² /(AWG)]	10, 10, 16 (6, 6, 6)		35, 25, 25 (2, 4, 4)		50 (1)				150 (300 MCM)	
IP21, IP55, IP66 max. cable cross-section (brake, load sharing) [mm ² /(AWG)]	10, 10, - (8, 8, -)		35, -, - (2, -, -)		50 (1)				95 (3/0)	
With line power disconnect switch included			16/6			35/2		35/2	70/3/0	185/kcmil350
Efficiency ³⁾	0.98	0.98	0.98	0.98	0.98	0.98	0.98	0.98	0.98	0.99

Table 8.4 Line Power Supply 3x380-480 V AC - Normal overload 110% for 1 minute, P11K-P90K

8.1.3 Line Power Supply 3x525–600 V AC

Type Designation	P1K1	P1K5	P2K2	P3K0	P3K7	P4K0	P5K5	P7K5
Typical Shaft Output [kW]	1.1	1.5	2.2	3.0	3.7	4.0	5.5	7.5
IP20/Chassis	A3	A3	A3	A3	A2	A3	A3	A3
IP21/NEMA 1	A3	A3	A3	A3	A2	A3	A3	A3
IP55/Type 12	A5	A5	A5	A5	A5	A5	A5	A5
IP66/NEMA 4X	A5	A5	A5	A5	A5	A5	A5	A5
Output current								
Continuous (3 x 525–550 V) [A]	2.6	2.9	4.1	5.2	-	6.4	9.5	11.5
Intermittent (3 x 525–550 V) [A]	2.9	3.2	4.5	5.7	-	7.0	10.5	12.7
Continuous (3x525–600 V) [A]	2.4	2.7	3.9	4.9	-	6.1	9.0	11.0
Intermittent (3x525–600 V) [A]	2.6	3.0	4.3	5.4	-	6.7	9.9	12.1
Continuous kVA (525 V AC) [kVA]	2.5	2.8	3.9	5.0	-	6.1	9.0	11.0
Continuous kVA (575 V AC) [kVA]	2.4	2.7	3.9	4.9	-	6.1	9.0	11.0
Max. input current								
Continuous (3x525–600 V) [A]	2.4	2.7	4.1	5.2	-	5.8	8.6	10.4
Intermittent (3x525–600 V) [A]	2.7	3.0	4.5	5.7	-	6.4	9.5	11.5
Additional specifications								
Estimated power loss at rated max. load [W] ⁴⁾	50	65	92	122	-	145	195	261
IP20 max. cable cross-section ⁵⁾ (line power, motor, brake and load sharing) [mm ² /(AWG)]	4, 4, 4 (12, 12, 12) (min. 0.2 (24))							
IP55, IP 66 max. cable cross-section ⁵⁾ (line power, motor, brake and load sharing) [mm ² /(AWG)]	4, 4, 4 (12, 12, 12) (min. 0.2 (24))							
Max. cable cross-section with disconnect	6, 4, 4 (12, 12, 12)							
Line power disconnect switch included	4/12							
Efficiency ³⁾	0.97	0.97	0.97	0.97	-	0.97	0.97	0.97

Table 8.5 Line Power Supply 3x525–600 V AC - Normal overload 110% for 1 minute, P1K1-P7K5

Type Designation	P11K	P15K	P18K	P22K	P30K	P37K	P45K	P55K	P75K	P90K
Typical Shaft Output [kW]	11	15	18.5	22	30	37	45	55	75	90
IP20/Chassis	B3	B3	B3	B4	B4	B4	C3	C3	C4	C4
IP21/NEMA 1	B1	B1	B1	B2	B2	C1	C1	C1	C2	C2
IP55/Type 12	B1	B1	B1	B2	B2	C1	C1	C1	C2	C2
IP66/NEMA 4X	B1	B1	B1	B2	B2	C1	C1	C1	C2	C2
Output current										
Continuous (3 x 525-550 V) [A]	19	23	28	36	43	54	65	87	105	137
Intermittent (3 x 525-550 V) [A]	21	25	31	40	47	59	72	96	116	151
Continuous (3x525-600 V) [A]	18	22	27	34	41	52	62	83	100	131
Intermittent (3x525-600 V) [A]	20	24	30	37	45	57	68	91	110	144
Continuous kVA (525 V AC) [kVA]	18.1	21.9	26.7	34.3	41	51.4	61.9	82.9	3.94 [100]	130.5
Continuous kVA (575 V AC) [kVA]	17.9	21.9	26.9	33.9	40.8	51.8	61.7	82.7	99.6	130.5
Max. input current										
Continuous (3x525-600 V) [A]	17.2	20.9	25.4	32.7	39	49	59	78.9	95.3	124.3
Intermittent (3x525-600 V) [A]	19	23	28	36	43	54	65	87	105	137
Additional specifications										
Estimated power loss at rated max. load [W] ⁴⁾	300	400	475	525	700	750	850	1100	1400	1500
IP21, IP55, IP66 max. cable cross-section (line power, brake and load sharing) [mm ² /(AWG)]	16, 10, 10 (6, 8, 8)		35, -, - (2, -, -)			50, -, - (1, -, -)			95 (4/0)	
IP21, IP55, IP66 max. cable cross-section (motor) [mm ² /(AWG)]	10, 10, - (8, 8, -)		35, 25, 25 (2, 4, 4)			50, -, - (1, -, -)			150 (300 MCM)	
IP20 max. cable cross-section (line power, brake and load sharing) [mm ² /(AWG)]	10, 10, - (8, 8, -)		35, -, - (2, -, -)			50, -, - (1, -, -)			150 (300 MCM)	
Max. cable cross-section with disconnect	16, 10, 10 (6, 8, 8)				50, 35, 35 (1, 2, 2)			95, 70, 70 (3/0, 2/0, 2/0)	185, 150, 120 (350 MCM, 300 MCM, 4/0)	
Line power disconnect switch included			16/6				35/2		70/3/0	185/kcmil350
Efficiency ³⁾	0.98	0.98	0.98	0.98	0.98	0.98	0.98	0.98	0.98	0.98

Table 8.6 Line Power Supply 3x525-600 V AC - Normal overload 110% for 1 minute, P11K-P90K

¹⁾ For type of fuse, see chapter 8.8 Fuses and Circuit Breakers.

²⁾ American Wire Gauge.

³⁾ Measured using 16 ft [5 m] shielded motor cables at rated load and rated frequency.

⁴⁾ The typical power loss is at normal load conditions and expected to be within $\pm 15\%$ (tolerance relates to variety in voltage and cable conditions).

Values are based on a typical motor efficiency. Lower efficiency motors will also add to the power loss in the adjustable frequency drive and vice versa.

If the switching frequency is raised from nominal, the power losses may rise significantly.

LCP and typical control card power consumption values are included. Further options and customer load may add up to 30 W to the losses. (Though typically only 4 W extra for a fully loaded control card or options for slot A or slot B, each).

Although measurements are made with state-of-the-art equipment, some measurement inaccuracy must be allowed for ($\pm 5\%$).

⁵⁾ The three values for the max. cable cross-section are for single core, flexible wire and flexible wire with sleeve, respectively. Motor and line cable: 300 MCM/150 mm².

⁶⁾ A2+A3 may be converted to IP21 using a conversion kit. See also Mechanical mounting and IP21/Type 1 Enclosure kit in the Design Guide.

⁷⁾ B3+4 and C3+4 may be converted to IP21 using a conversion kit. See also Mechanical mounting and IP21/Type 1 Enclosure kit in the Design Guide.

8.2 Line Power Supply

Line power supply

Supply Terminals	L1, L2, L3
Supply voltage	200–240 V $\pm 10\%$
Supply voltage	380–480 V $\pm 10\%$
Supply voltage	525–600 V $\pm 10\%$

AC line voltage low/line drop-out:

During low AC line voltage or a line drop-out, the adjustable frequency drive continues until the intermediate circuit voltage drops below the minimum stop level, which corresponds typically to 15% below the adjustable frequency drive's lowest rated supply voltage. Power-up and full torque cannot be expected at AC line voltage lower than 10% below the adjustable frequency drive's lowest rated supply voltage.

Supply frequency	50/60 Hz $\pm 5\%$
Max. temporary imbalance between line phases	3.0% of rated supply voltage
True Power Factor (λ)	≥ 0.9 nominal at rated load
Displacement Power Factor ($\cos \phi$)	Near unity (> 0.98)
Switching on input supply L1, L2, L3 (power-ups) ≤ 7.5 kW	Maximum 2 times/min.
Switching on input supply L1, L2, L3 (power-ups) 11–75 kW	Maximum 1 time/min.
Switching on input supply L1, L2, L3 (power-ups) ≥ 90 kW	Maximum 1 time/2 min.
Environment according to EN60664-1	Overvoltage category III/pollution degree 2

The unit is suitable for use on a circuit capable of delivering not more than 100,000 RMS symmetrical Amperes, 240/500/600/690 V maximum.

8.3 Motor Output and Motor Data

Motor output (U, V, W)

Output voltage	0–100% of supply voltage
Output frequency (1.1–90 kW)	0–590 ¹⁾ Hz
Switching on output	Unlimited
Ramp times	1–3600 s

¹⁾ As of software version 1.10, the output frequency of the adjustable frequency drive is limited to 590 Hz. Contact local Danfoss partner for further information.

Torque characteristics

Starting torque (Constant torque)	maximum 110% for 1 min. ¹⁾
Starting torque	maximum 135% up to 0.5 s ¹⁾
Overload torque (Constant torque)	maximum 110% for 1 min. ¹⁾

¹⁾ Percentage relates to the nominal torque.

8.4 Ambient Conditions

Environment

IP rating	IP20 ¹⁾ /Chassis, IP21 ²⁾ /Type 1, IP55/Type 12, IP66/Type 4X
Vibration test	1.0 g
Max. relative humidity	5%–93% (IEC 721-3-3; Class 3K3 (non-condensing) during operation
Aggressive environment (IEC 60068-2-43) H ₂ S test	class Kd
Ambient temperature ³⁾	Max. 122°F [50°C] (24-hour average maximum 113°F [45°C])
Minimum ambient temperature during full-scale operation	32°F [0°C]
Minimum ambient temperature at reduced performance	14°F [-10°C]
Temperature during storage/transport	-13°–+149°/158°F [-25°–+65°/70°C]
Maximum altitude above sea level without derating	3300 ft [1000 m]

Derating for high altitude, see special conditions in the Design Guide.

EMC standards, Emission	EN 61800-3
EMC standards, Immunity	EN 61800-3

See section on special conditions in the Design Guide.

¹⁾ Only for ≤ 3.7 kW (200–240 V), ≤ 7.5 kW (380–480 V)

²⁾ As enclosure kit for ≤ 3.7 kW (200–240 V), ≤ 7.5 kW (380–480 V)

³⁾ Derating for high ambient temperature, see special conditions in the Design Guide

8.5 Cable Specifications

Cable lengths and cross-sections for control cables¹⁾

Max. motor cable length, shielded	500 ft [150 m]
Max. motor cable length, non-shielded	1000 ft [300 m]
Maximum cross-section to control terminals, flexible/ rigid wire without cable end sleeves	1.5 mm ² /16 AWG
Maximum cross-section to control terminals, flexible wire with cable end sleeves	1 mm ² /18 AWG
Maximum cross-section to control terminals, flexible wire with cable end sleeves with collar	0.5 mm ² /20 AWG
Minimum cross-section to control terminals	0.25 mm ² /24 AWG

¹⁾ For power cables, see electrical data tables in chapter 8.1 Electrical Data.

8.6 Control Input/Output and Control Data

Digital inputs

Programmable digital inputs	4 (6) ¹⁾
Terminal number	18, 19, 27 ¹⁾ , 29 ¹⁾ , 32, 33,
Logic	PNP or NPN
Voltage level	0–24 V DC
Voltage level, logic '0' PNP	<5 V DC
Voltage level, logic '1' PNP	>10 V DC
Voltage level, logic '0' NPN ²⁾	>19 V DC
Voltage level, logic '1' NPN ²⁾	<14 V DC
Maximum voltage on input	28 V DC
Pulse frequency ranges (Duty cycle) Min. pulse width	0–110 kHz 4.5 ms
Input resistance, R _i	Approx. 4 kΩ

Safe Torque Off Terminal 37³⁾, ⁴⁾ (Terminal 37 is fixed PNP logic)

Voltage level	0–24 V DC
Voltage level, logic '0' PNP	<4 V DC
Voltage level, logic '1' PNP	>20 V DC
Maximum voltage on input	28 V DC
Typical input current at 24 V	50 mA rms
Typical input current at 20 V	60 mA rms
Input capacitance	400 nF

All digital inputs are galvanically isolated from the supply voltage (PELV) and other high-voltage terminals.

¹⁾ Terminals 27 and 29 can also be programmed as output.

²⁾ Except Safe Torque Off input Terminal 37.

³⁾ See chapter 4.8 Control Wiring for further information about terminal 37 and Safe Torque Off.

⁴⁾ When using a contactor with a DC coil inside in combination with Safe Torque Off, it is important to make a return way for the current from the coil when turning it off. This can be done by using a freewheel diode (or, alternatively, a 30 or 50 V MOV for quicker response time) across the coil. Typical contactors can be bought with this diode.

Analog inputs

Number of analog inputs	2
Terminal number	53, 54
Modes	Voltage or current
Mode select	Switch S201 and switch S202
Voltage mode	Switch S201/switch S202 = OFF (U)
Voltage level	-10 to +10 V (scaleable)
Input resistance, R _i	Approx. 10 kΩ
Max. voltage	±20 V
Current mode	Switch S201/switch S202 = ON (I)
Current level	0/4 to 20 mA (scaleable)
Input resistance, R _i	Approx. 200 Ω
Max. current	30 mA
Resolution for analog inputs	10 bit (+ sign)
Accuracy of analog inputs	Max. error 0.5% of full scale
Bandwidth	100 Hz

The analog inputs are galvanically isolated from the supply voltage (PELV) and other high-voltage terminals.

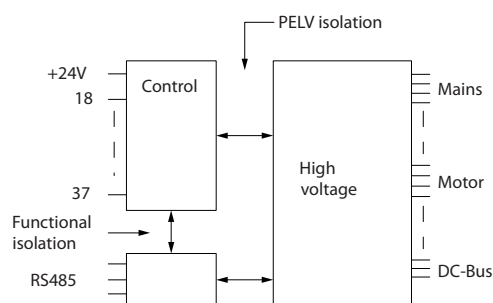

Figure 8.1 PELV Isolation of Analog Inputs

Pulse inputs

Programmable pulse	2/1
Terminal number pulse	29, 33 ¹⁾ /32 ²⁾ , 33 ²⁾
Max. frequency at terminal 29, 32, 33	110 kHz (push-pull driven)
Max. frequency at terminal 29, 32, 33	5 kHz (open collector)
Min. frequency at terminal 29, 32, 33	4 Hz
Voltage level	See chapter 8.6.1 Digital Inputs
Maximum voltage on input	28 V DC
Input resistance, R _i	Approx. 4 kΩ
Pulse input accuracy (0.1–1 kHz)	Max. error: 0.1% of full scale
Encoder input accuracy (1–11 kHz)	Max. error: 0.05% of full scale

The pulse and encoder inputs (terminals 29, 32, 33) are galvanically isolated from the supply voltage (PELV) and other high-voltage terminals.

¹⁾ Pulse inputs are 29 and 33

²⁾ Encoder inputs: 32 = A, and 33 = B

Analog output

Number of programmable analog outputs	1
Terminal number	42
Current range at analog output	0/4–20 mA
Max. load GND - analog output	500 Ω
Accuracy on analog output	Max. error: 0.5% of full scale
Resolution on analog output	12 bit

The analog output is galvanically isolated from the supply voltage (PELV) and other high-voltage terminals.

Control card, RS-485 serial communication

Terminal number	68 (P,TX+, RX+), 69 (N,TX-, RX-)
Terminal number 61	Common for terminals 68 and 69

The RS-485 serial communication circuit is functionally separated from other central circuits and galvanically isolated from the supply voltage (PELV).

Digital output

Programmable digital/pulse outputs	2
Terminal number	27, 29 ¹⁾
Voltage level at digital/frequency output	0–24 V
Max. output current (sink or source)	40 mA
Max. load at frequency output	1 kΩ
Max. capacitive load at frequency output	10 nF
Minimum output frequency at frequency output	0 Hz
Maximum output frequency at frequency output	32 kHz
Accuracy of frequency output	Max. error: 0.1% of full scale
Resolution of frequency outputs	12 bit

¹⁾ Terminal 27 and 29 can also be programmed as input.

The digital output is galvanically isolated from the supply voltage (PELV) and other high-voltage terminals.

Control card, 24 V DC output

Terminal number	12, 13
Output voltage	24 V +1, -3 V
Max. load	200 mA

The 24 V DC supply is galvanically isolated from the supply voltage (PELV), but has the same potential as the analog and digital inputs and outputs.

Relay outputs

Programmable relay outputs	
Relay 01 Terminal number	1-3 (break), 1-2 (make)
Max. terminal load (AC-1) ¹⁾ on 1-3 (NC), 1-2 (NO) (Resistive load)	240 V AC, 2 A
Max. terminal load (AC-15) ¹⁾ (Inductive load @ cosφ 0.4)	240 V AC, 0.2 A
Max. terminal load (DC-1) ¹⁾ on 1-2 (NO), 1-3 (NC) (Resistive load)	60 V DC, 1 A
Max. terminal load (DC-13) ¹⁾ (Inductive load)	24 V DC, 0.1 A
Relay 02 Terminal number	4-6 (break), 4-5 (make)
Max. terminal load (AC-1) ¹⁾ on 4-5 (NO) (Resistive load) ²⁾³⁾ Overvoltage cat. II	400 V AC, 2 A
Max. terminal load (AC-15) ¹⁾ on 4-5 (NO) (Inductive load @ cosφ 0.4)	240 V AC, 0.2 A
Max. terminal load (DC-1) ¹⁾ on 4-5 (NO) (resistive load)	80 V DC, 2 A
Max. terminal load (DC-13) ¹⁾ on 4-5 (NO) (inductive load)	24 V DC, 0.1 A
Max. terminal load (AC-1) ¹⁾ on 4-6 (NC) (resistive load)	240 V AC, 2 A
Max. terminal load (AC-15) ¹⁾ on 4-6 (NC) (Inductive load @ cosφ 0.4)	240 V AC, 0.2 A
Max. terminal load (DC-1) ¹⁾ on 4-6 (NC) (resistive load)	50 V DC, 2 A
Max. terminal load (DC-13) ¹⁾ on 4-6 (NC) (inductive load)	24 V DC, 0.1 A
Min. terminal load on 1-3 (NC), 1-2 (NO), 4-6 (NC), 4-5 (NO)	24 V DC 10 mA, 24 V AC 20 mA
Environment according to EN 60664-1	Overvoltage category III/pollution degree 2

¹⁾ IEC 60947 part 4 and 5

The relay contacts are galvanically isolated from the rest of the circuit by reinforced isolation (PELV).

²⁾ Overvoltage Category II

³⁾ UL applications 300 V AC 2A

Control card, 10 V DC output

Terminal number	50
Output voltage	10.5 V \pm 0.5 V
Max. load	15 mA

The 10 V DC supply is galvanically isolated from the supply voltage (PELV) and other high-voltage terminals.

Control characteristics

Resolution of output frequency at 0–590 Hz	\pm 0.003 Hz
Repeat accuracy of <i>Precise start/stop</i> (terminals 18, 19)	$\leq \pm$ 0.1 ms
System response time (terminals 18, 19, 27, 29, 32, 33)	\leq 2 ms
Speed control range (open-loop)	1:100 of synchronous speed
Speed control range (closed-loop)	1:1000 of synchronous speed
Speed accuracy (open-loop)	30–4000 rpm: error \pm 8 rpm
Speed accuracy (closed-loop), depending on resolution of feedback device	0–6000 rpm: error \pm 0.15 rpm

All control characteristics are based on a 4-pole asynchronous motor

Control card performance

Scan interval	1 ms
---------------	------

Control card, USB serial communication

USB standard	1.1 (full speed)
USB plug	USB type B “device” plug

Connection to PC is carried out via a standard host/device USB cable.

The USB connection is galvanically isolated from the supply voltage (PELV) and other high-voltage terminals.

The USB ground connection is not galvanically isolated from protection ground. Use only an isolated laptop as PC connection to the USB connector on the adjustable frequency drive.

8.7 Connection Tightening Torques

Enclosure	Power (hp [kW])			Torque (in-lb [Nm])			
	200–240 V	380–480 V	525–600 V	Line power	Motor	Ground	Relay
A2	1.5–3 [1.1–2.2]	1.5–5 [1.1–4.0]		15.93 [1.8]	15.93 [1.8]	26.55 [3]	5.31 [0.6]
A3	4–5 [3.0–3.7]	7.5–10 [5.5–7.5]	1.5–10 [1.1–7.5]	15.93 [1.8]	15.93 [1.8]	26.55 [3]	5.31 [0.6]
A4	1.5–3 [1.1–2.2]	1.5–5 [1.1–4.0]		15.93 [1.8]	15.93 [1.8]	26.55 [3]	5.31 [0.6]
A5	1.5–5 [1.1–3.7]	1.5–10 [1.1–7.5]	1.5–10 [1.1–7.5]	15.93 [1.8]	15.93 [1.8]	26.55 [3]	5.31 [0.6]
B1	7.5–10 [5.5–7.5]	15–20 [11–15]	15–20 [11–15]	15.93 [1.8]	15.93 [1.8]	26.55 [3]	5.31 [0.6]
B2	15 [11]	24 [18] 30 [22]	24 [18] 30 [22]	39.83 [4.5] 39.83 [4.5]	39.83 [4.5] 39.83 [4.5]	26.55 [3] 26.55 [3]	5.31 [0.6] 5.31 [0.6]
B3	7.5–10 [5.5–7.5]	15–20 [11–15]	15–20 [11–15]	15.93 [1.8]	15.93 [1.8]	26.55 [3]	5.31 [0.6]
B4	15–20 [11–15]	24–40 [18–30]	24–40 [18–30]	39.83 [4.5]	39.83 [4.5]	26.55 [3]	5.31 [0.6]
C1	20–30 [15–22]	40–60 [30–45]	40–60 [30–45]	88.51 [10]	88.51 [10]	26.55 [3]	5.31 [0.6]
C2	40–50 [30–37]	75–100 [55–75]	75–100 [55–75]	123.91/212.42 [14/24] ¹⁾	123.91/212.42 [14/24] ¹⁾	26.55 [3]	5.31 [0.6]
C3	24–30 [18–22]	50–60 [37–45]	50–60 [37–45]	88.51 [10]	88.51 [10]	26.55 [3]	5.31 [0.6]
C4	40–50 [30–37]	75–100 [55–75]	75–100 [55–75]	123.91/212.42 [14/24] ¹⁾	123.91/212.42 [14/24] ¹⁾	26.55 [3]	5.31 [0.6]

Table 8.7 Tightening of Terminals

¹⁾ For different cable dimensions x/y, where x \leq 4/0 AWG [95 mm²] and y \geq 4/0 AWG [95 mm²].

8.8 Fuses and Circuit Breakers

Use recommended fuses and/or circuit breakers on the supply side as protection in case of component breakdown inside the adjustable frequency drive (first fault).

NOTICE!

Use of fuses on the supply side is mandatory for IEC 60364 (CE) and NEC 2009 (UL) compliant installations.

Recommendations

- Fuses of the type gG
- Circuit breakers of Moeller types. When using other circuit breaker types, ensure that the energy going into the adjustable frequency drive is equal to or lower than the energy provided by Moeller types.

If recommended fuses/circuit breakers are chosen, possible damages to the adjustable frequency drive will mainly be limited to damages inside the unit. For further information, see *Application Note Fuses and Circuit Breakers, MN90T*.

The fuses below are suitable for use on a circuit capable of delivering 100,000 Arms (symmetrical), depending on the adjustable frequency drive voltage rating. With the proper fusing the adjustable frequency drive Short Circuit Current Rating (SCCR) is 100,000 Arms.

8.8.1 CE Compliance

200–240 V

Enclosure type	Power (hp [kW])	Recommended fuse size	Recommended max. fuse size	Recommended circuit breaker (Moeller)	Max. trip level [A]
A2	1.5–3 [1.1–2.2]	gG-10 (1.5–2 [1.1–1.5]) gG-16 (3 [2.2])	gG-25	PKZM0-25	25
A3	4–5 [3.0–3.7]	gG-16 (4 [3]) gG-20 (5 [3.7])	gG-32	PKZM0-25	25
B3	7.5–15 [5.5–11]	gG-25 (7.5–10 [5.5–7.5]) gG-32 (15 [11])	gG-63	PKZM4-50	50
B4	20–24 [15–18]	gG-50 (20 [15]) gG-63 (25 [18])	gG-125	NZMB1-A100	3.94 [100]
C3	30–40 [22–30]	gG-80 (30 [22]) aR-125 (40 [30])	gG-150 (22) aR-160 (30)	NZMB2-A200	150
C4	50–60 [37–45]	aR-160 (50 [37]) aR-200 (60 [45])	aR-200 (50 [37]) aR-250 (60 [45])	NZMB2-A250	250
A4	1.5–3 [1.1–2.2]	gG-10 (1.5–2 [1.1–1.5]) gG-16 (3 [2.2])	gG-32	PKZM0-25	25
A5	0.34–5 [0.25–3.7]	gG-10 (0.34–2 [0.25–1.5]) gG-16 (3–4 [2.2–3]) gG-20 (5 [3.7])	gG-32	PKZM0-25	25
B1	7.5–15 [5.5–11]	gG-25 (7.5 [5.5]) gG-32 (10–15 [7.5–11])	gG-80	PKZM4-63	63
B2	15	gG-50	gG-100	NZMB1-A100	100
C1	24–40 [18–30]	gG-63 (25 [18.5]) gG-80 (30 [22]) gG-100 (40 [30])	gG-160 (25–30 [18.5–22]) aR-160 (40 [30])	NZMB2-A200	160
C2	50–60 [37–45]	aR-160 (50 [37]) aR-200 (60 [45])	aR-200 (50 [37]) aR-250 (60 [45])	NZMB2-A250	250

Table 8.8 200–240 V, Enclosure Types A, B and C

380–480 V

Enclosure type	Power (hp [kW])	Recommended fuse size	Recommended max. fuse size	Recommended circuit breaker (Moeller)	Max. trip level [A]
A2	1.5–5 [1.1–4.0]	gG-10 (1.5–4 [1.1–3]) gG-16 (5 [4])	gG-25	PKZM0-25	25
A3	7.5–10 [5.5–7.5]	gG-16	gG-32	PKZM0-25	25
B3	15–24 [11–18]	gG-40	gG-63	PKZM4-50	50
B4	30–50 [22–37]	gG-50 (30 [22]) gG-63 (40 [30]) gG-80 (50 [37])	gG-125	NZMB1-A100	3.94 [100]
C3	60–75 [45–55]	gG-100 (60 [45]) gG-160 (75 [55])	gG-150 (60 [45]) gG-160 (75 [55])	NZMB2-A200	150
C4	100–125 [75–90]	aR-200 (100 [75]) aR-250 (125 [90])	aR-250	NZMB2-A250	250
A4	1.5–5 [1.1–4]	gG-10 (1.5–4 [1.1–3]) gG-16 (5 [4])	gG-32	PKZM0-25	25
A5	1.5–10 [1.1–7.5]	gG-10 (1.5–4 [1.1–3]) gG-16 (5–10 [4–7.5])	gG-32	PKZM0-25	25
B1	15–25 [11–18.5]	gG-40	gG-80	PKZM4-63	63
B2	30–40 [22–30]	gG-50 (30 [22]) gG-63 (40 [30])	gG-100	NZMB1-A100	100
C1	50–75 [37–55]	gG-80 (50 [37]) gG-100 (60 [45]) gG-160 (75 [55])	gG-160	NZMB2-A200	160
C2	100–125 [75–90]	aR-200 (100 [75]) aR-250 (125 [90])	aR-250	NZMB2-A250	250

Table 8.9 380–480 V, Enclosure Types A, B and C

525–600 V

Enclosure type	Power (hp [kW])	Recommended fuse size	Recommended max. fuse size	Recommended circuit breaker (Moeller)	Max. trip level [A]
A3	7.5–10 [5.5–7.5]	gG-10 (7.5 [5.5]) gG-16 (10 [7.5])	gG-32	PKZM0-25	25
B3	15–24 [11–18]	gG-25 (15 [11]) gG-32 (20–25 [15–18])	gG-63	PKZM4-50	50
B4	30–50 [22–37]	gG-40 (30 [22]) gG-50 (40 [30]) gG-63 (50 [37])	gG-125	NZMB1-A100	100
C3	60–75 [45–55]	gG-63 (60 [45]) gG-100 (75 [55])	gG-150	NZMB2-A200	150
C4	100–125 [75–90]	aR-160 (100 [75]) aR-200 (125 [90])	aR-250	NZMB2-A250	250
A5	1.5–10 [1.1–7.5]	gG-10 (1.5–7.5 [1.1–5.5]) gG-16 (10 [7.5])	gG-32	PKZM0-25	25
B1	15–24 [11–18]	gG-25 (15 [11]) gG-32 (20 [15]) gG-40 (25 [18.5])	gG-80	PKZM4-63	63
B2	30–40 [22–30]	gG-50 (30 [22]) gG-63 (40 [30])	gG-100	NZMB1-A100	100
C1	50–75 [37–55]	gG-63 (50 [37]) gG-100 (60 [45]) aR-160 (75 [55])	gG-160 (50–60 [37–45]) aR-250 (75 [55])	NZMB2-A200	160
C2	100–125 [75–90]	aR-200 (100–125 [75–90])	aR-250	NZMB2-A250	250

Table 8.10 525–600 V, Enclosure Types A, B and C

8.8.2 UL Compliance

1 x 200-240 V

Power [kW]	Max prefuse size [A]	Bussmann JFHR2	Recommended max. fuse										
			Bussmann RK1	Bussmann J	Bussmann T	Bussmann CC	Bussmann CC	Bussmann CC	SIBA RK1	Littel fuse RK1	Ferraz-Shawmut CC	Ferraz-Shawmut RK1	Ferraz-Shawmut J
1.1	15	FWX-15	KTN-R15	JKS-15	JJN-15	FNQ-R15	KTK-R15	LP-CC-15	5017906-016	KLN-R15	ATM-R15	A2K-15R	HSJ15
1.5	20	FWX-20	KTN-R20	JKS-20	JJN-20	FNQ-R20	KTK-R20	LP-CC-20	5017906-020	KLN-R20	ATM-R20	A2K-20R	HSJ20
2.2	30*	FWX-30	KTN-R30	JKS-30	JJN-30	FNQ-R30	KTK-R30	LP-CC-30	5012406-032	KLN-R30	ATM-R30	A2K-30R	HSJ30
3.0	35	FWX-35	KTN-R35	JKS-35	JJN-35				---	KLN-R35	---	A2K-35R	HSJ35
3.7	50	FWX-50	KTN-R50	JKS-50	JJN-50				5014006-050	KLN-R50	---	A2K-50R	HSJ50
5.5	60**	FWX-60	KTN-R60	JKS-60	JJN-60				5014006-063	KLN-R60	---	A2K-60R	HSJ60
7.5	80	FWX-80	KTN-R80	JKS-80	JJN-80				5014006-080	KLN-R80	---	A2K-80R	HSJ80
15	150	FWX-150	KTN-R150	JKS-150	JJN-150				2028220-150	KLN-R150		A2K-150R	HSJ150
22	200	FWX-200	KTN-R200	JKS-200	JJN-200				2028220-200	KLN-R200		A2K-200R	HSJ200

Table 8.11 1 x 200-240 V

* Siba allowed up to 32 A ; ** Siba allowed up to 63 A

3x200-240 V

Power [kW]	Recommended max. fuse					
	Bussmann Type RK1 ¹⁾	Bussmann Type J	Bussmann Type T	Bussmann Type CC	Bussmann Type CC	Bussmann Type CC
1.1	KTN-R-10	JKS-10	JJN-10	FNQ-R-10	KTK-R-10	LP-CC-10
1.5	KTN-R-15	JKS-15	JJN-15	FNQ-R-15	KTK-R-15	LP-CC-15
2.2	KTN-R-20	JKS-20	JJN-20	FNQ-R-20	KTK-R-20	LP-CC-20
3.0	KTN-R-25	JKS-25	JJN-25	FNQ-R-25	KTK-R-25	LP-CC-25
3.7	KTN-R-30	JKS-30	JJN-30	FNQ-R-30	KTK-R-30	LP-CC-30
5.5/7.5	KTN-R-50	KS-50	JJN-50	-	-	-
11	KTN-R-60	JKS-60	JJN-60	-	-	-
15	KTN-R-80	JKS-80	JJN-80	-	-	-
18.5-22	KTN-R-125	JKS-125	JJN-125	-	-	-
30	KTN-R-150	JKS-150	JJN-150	-	-	-
37	KTN-R-200	JKS-200	JJN-200	-	-	-
45	KTN-R-250	JKS-250	JJN-250	-	-	-

Table 8.12 3x200-240 V, Enclosure Types A, B and C

Power [kW]	Recommended max. fuse							
	SIBA Type RK1	Littel fuse Type RK1	Ferraz-Shawmut Type CC	Ferraz-Shawmut Type RK1 ³⁾	Bussmann Type JFHR2 ²⁾	Littel fuse JFHR2	Ferraz-Shawmut JFHR2 ⁴⁾	Ferraz-Shawmut J
1.1	5017906-010	KLN-R-10	ATM-R-10	A2K-10-R	FWX-10	-	-	HSJ-10
1.5	5017906-016	KLN-R-15	ATM-R-15	A2K-15-R	FWX-15	-	-	HSJ-15
2.2	5017906-020	KLN-R-20	ATM-R-20	A2K-20-R	FWX-20	-	-	HSJ-20
3.0	5017906-025	KLN-R-25	ATM-R-25	A2K-25-R	FWX-25	-	-	HSJ-25
3.7	5012406-032	KLN-R-30	ATM-R-30	A2K-30-R	FWX-30	-	-	HSJ-30
5.5/7.5	5014006-050	KLN-R-50	-	A2K-50-R	FWX-50	-	-	HSJ-50
11	5014006-063	KLN-R-60	-	A2K-60-R	FWX-60	-	-	HSJ-60
15	5014006-080	KLN-R-80	-	A2K-80-R	FWX-80	-	-	HSJ-80
18.5-22	2028220-125	KLN-R-125	-	A2K-125-R	FWX-125	-	-	HSJ-125
30	2028220-150	KLN-R-150	-	A2K-150-R	FWX-150	L25S-150	A25X-150	HSJ-150
37	2028220-200	KLN-R-200	-	A2K-200-R	FWX-200	L25S-200	A25X-200	HSJ-200
45	2028220-250	KLN-R-250	-	A2K-250-R	FWX-250	L25S-250	A25X-250	HSJ-250

Table 8.13 3x200-240 V, Enclosure Types A, B and C

- ¹⁾ KTS-fuses from Bussmann may substitute KTN for 240 V frequency converters.
- ²⁾ FWH-fuses from Bussmann may substitute FWX for 240 V frequency converters.
- ³⁾ A6KR fuses from FERRAZ SHAWMUT may substitute A2KR for 240 V frequency converters.
- ⁴⁾ A50X fuses from FERRAZ SHAWMUT may substitute A25X for 240 V frequency converters.

3x380-480 V

Power [kW]	Recommended max. fuse					
	Bussmann Type RK1	Bussmann Type J	Bussmann Type T	Bussmann Type CC	Bussmann Type CC	Bussmann Type CC
1.1	KTS-R-6	JKS-6	JJS-6	FNQ-R-6	KTK-R-6	LP-CC-6
1.5-2.2	KTS-R-10	JKS-10	JJS-10	FNQ-R-10	KTK-R-10	LP-CC-10
3	KTS-R-15	JKS-15	JJS-15	FNQ-R-15	KTK-R-15	LP-CC-15
4	KTS-R-20	JKS-20	JJS-20	FNQ-R-20	KTK-R-20	LP-CC-20
5.5	KTS-R-25	JKS-25	JJS-25	FNQ-R-25	KTK-R-25	LP-CC-25
7.5	KTS-R-30	JKS-30	JJS-30	FNQ-R-30	KTK-R-30	LP-CC-30
11/15	KTS-R-40	JKS-40	JJS-40	-	-	-
18	KTS-R-50	JKS-50	JJS-50	-	-	-
22	KTS-R-60	JKS-60	JJS-60	-	-	-
30	KTS-R-80	JKS-80	JJS-80	-	-	-
37	KTS-R-100	JKS-100	JJS-100	-	-	-
45	KTS-R-125	JKS-125	JJS-125	-	-	-
55	KTS-R-150	JKS-150	JJS-150	-	-	-
75	KTS-R-200	JKS-200	JJS-200	-	-	-
90	KTS-R-250	JKS-250	JJS-250	-	-	-

Table 8.14 3x380-480 V, Enclosure Types A, B and C

Power [kW]	Recommended max. fuse							
	SIBA Type RK1	Littel fuse Type RK1	Ferraz-Shawmut Type CC	Ferraz-Shawmut Type RK1	Bussmann JFHR2	Ferraz-Shawmut J	Ferraz-Shawmut JFHR2 ¹⁾	Littel fuse JFHR2
1.1-2.2	5017906-010	KLS-R-10	ATM-R-10	A6K-10-R	FWH-10	HSJ-10	-	-
3	5017906-016	KLS-R-15	ATM-R-15	A6K-15-R	FWH-15	HSJ-15	-	-
4	5017906-020	KLS-R-20	ATM-R-20	A6K-20-R	FWH-20	HSJ-20	-	-
5.5	5017906-025	KLS-R-25	ATM-R-25	A6K-25-R	FWH-25	HSJ-25	-	-
7.5	5012406-032	KLS-R-30	ATM-R-30	A6K-30-R	FWH-30	HSJ-30	-	-
11/15	5014006-040	KLS-R-40	-	A6K-40-R	FWH-40	HSJ-40	-	-
18	5014006-050	KLS-R-50	-	A6K-50-R	FWH-50	HSJ-50	-	-
22	5014006-063	KLS-R-60	-	A6K-60-R	FWH-60	HSJ-60	-	-
30	2028220-100	KLS-R-80	-	A6K-80-R	FWH-80	HSJ-80	-	-
37	2028220-125	KLS-R-100	-	A6K-100-R	FWH-100	HSJ-100	-	-
45	2028220-125	KLS-R-125	-	A6K-125-R	FWH-125	HSJ-125	-	-
55	2028220-160	KLS-R-150	-	A6K-150-R	FWH-150	HSJ-150	-	-
75	2028220-200	KLS-R-200	-	A6K-200-R	FWH-200	HSJ-200	A50-P-225	L50-S-225
90	2028220-250	KLS-R-250	-	A6K-250-R	FWH-250	HSJ-250	A50-P-250	L50-S-250

Table 8.15 3x380-480 V, Enclosure Types A, B and C

¹⁾ Ferraz-Shawmut A50QS fuses may substitute A50P fuses.

3x525-600 V

Power [kW]	Recommended max. fuse									
	Bussmann Type RK1	Bussmann Type J	Bussmann Type T	Bussmann Type CC	Bussmann Type CC	Bussmann Type CC	SIBA Type RK1	Littel fuse Type RK1	Ferraz-Shawmut Type RK1	Ferraz-Shawmut J
1.1	KTS-R-5	JKS-5	JJS-6	FNQ-R-5	KTK-R-5	LP-CC-5	5017906-005	KLS-R-005	A6K-5-R	HSJ-6
1.5-2.2	KTS-R-10	JKS-10	JJS-10	FNQ-R-10	KTK-R-10	LP-CC-10	5017906-010	KLS-R-010	A6K-10-R	HSJ-10
3	KTS-R15	JKS-15	JJS-15	FNQ-R-15	KTK-R-15	LP-CC-15	5017906-016	KLS-R-015	A6K-15-R	HSJ-15
4	KTS-R20	JKS-20	JJS-20	FNQ-R-20	KTK-R-20	LP-CC-20	5017906-020	KLS-R-020	A6K-20-R	HSJ-20
5.5	KTS-R-25	JKS-25	JJS-25	FNQ-R-25	KTK-R-25	LP-CC-25	5017906-025	KLS-R-025	A6K-25-R	HSJ-25
7.5	KTS-R-30	JKS-30	JJS-30	FNQ-R-30	KTK-R-30	LP-CC-30	5017906-030	KLS-R-030	A6K-30-R	HSJ-30
11/15	KTS-R-35	JKS-35	JJS-35	-	-	-	5014006-040	KLS-R-035	A6K-35-R	HSJ-35
18	KTS-R-45	JKS-45	JJS-45	-	-	-	5014006-050	KLS-R-045	A6K-45-R	HSJ-45
22	KTS-R-50	JKS-50	JJS-50	-	-	-	5014006-050	KLS-R-050	A6K-50-R	HSJ-50
30	KTS-R-60	JKS-60	JJS-60	-	-	-	5014006-063	KLS-R-060	A6K-60-R	HSJ-60
37	KTS-R-80	JKS-80	JJS-80	-	-	-	5014006-080	KLS-R-075	A6K-80-R	HSJ-80
45	KTS-R-100	JKS-100	JJS-100	-	-	-	5014006-100	KLS-R-100	A6K-100-R	HSJ-100
55	KTS-R-125	JKS-125	JJS-125	-	-	-	2028220-125	KLS-R-125	A6K-125-R	HSJ-125
75	KTS-R-150	JKS-150	JJS-150	-	-	-	2028220-150	KLS-R-150	A6K-150-R	HSJ-150
90	KTS-R-175	JKS-175	JJS-175	-	-	-	2028220-200	KLS-R-175	A6K-175-R	HSJ-175

Table 8.16 3x525-600 V, Enclosure Types A, B and C

8.9 Power Ratings, Weight and Dimensions

Enclosure Type [kW]	A2	A3	A4	A5	B1	B2	B3	B4	C1	C2	C3	C4
200-240 V	1.1-2.2	3.0-3.7	1.1-2.2	1.1-3.7	5.5-11	15	5.5-11	15-18.5	18.5-30	37-45	22-30	37-45
380-480 V	1.1-4.0	5.5-7.5	1.1-4.0	1.1-7.5	11-18.5	22-30	11-18.5	22-37	37-55	75-90	45-55	75-90
525-600 V	1.1-7.5	1.1-7.5	1.1-7.5	1.1-7.5	11-18.5	11-30	11-18.5	22-37	37-55	37-90	45-55	75-90
IP	20	20	21	55/66	21/55/66	21/55/66	20	20	21/55/66	21/55/66	20	20
NEMA	Chassis Type 1	Chassis Type 1	Type 1	Type 12/4X	Type 1/12/4X	Type 1/12/4X	Chassis	Chassis	Type 1/12/4X	Type 1/12/4X	Chassis	Chassis
Height (in [mm])												
Enclosure	A*	9.69 [246]	14.65 [372]	15.35 [390]	18.89 [480]	25.59 [650]	13.78 [350]	18.11 [460]	26.77 [680]	30.32 [770]	19.29 [490]	23.62 [600]
Height of backplate	A	10.55 [268]	14.76 [375]	15.35 [390]	18.89 [480]	25.59 [650]	15.77 [399]	10.51 [520]	26.77 [680]	30.32 [770]	21.65 [550]	25.98 [660]
Height with decoupling plate for serial communication bus cables	A	14.72 [374]	-	-	-	-	16.5 [419]	23.43 [595]	-	-	24.8 [630]	31.5 [800]
Distance between mounting holes	a	10.12 [257]	13.78 [350]	15.79 [401]	17.87 [454]	25.57 [624]	14.96 [380]	19.49 [495]	25.5 [648]	29.1 [739]	20.51 [521]	24.84 [631]
Width (in [mm])												
Enclosure	B	3.54 [90]	5.12 [130]	7.87 [200]	9.53 [242]	9.53 [242]	6.5 [165]	9.1 [231]	12.93 [308]	14.57 [370]	12.93 [308]	14.57 [370]
Width of backplate	B	3.54 [90]	5.12 [130]	7.87 [200]	9.53 [242]	9.53 [242]	6.5 [165]	9.1 [231]	12.93 [308]	14.57 [370]	12.93 [308]	14.57 [370]
Width of backplate with one C option	B	5.12 [130]	6.69 [170]	9.53 [242]	9.53 [242]	9.53 [242]	8.07 [205]	9.1 [231]	12.93 [308]	14.57 [370]	12.93 [308]	14.57 [370]
Distance between mounting holes	b	2.76 [70]	4.33 [110]	6.73 [171]	8.47 [215]	8.27 [210]	5.51 [140]	7.87 [200]	10.71 [272]	13.15 [334]	10.63 [270]	13 [330]
Depth** (in [mm])												
Without option A/B	C	8.07 [205]	8.07 [205]	6.89 [175]	7.87 [200]	10.24 [260]	9.76 [248]	9.53 [242]	12.21 [310]	13.19 [335]	13.11 [333]	13.11 [333]
With option A/B	C	8.66 [220]	8.66 [220]	6.89 [175]	7.87 [200]	10.24 [260]	10.32 [262]	9.53 [242]	12.21 [310]	13.19 [335]	13.11 [333]	13.11 [333]



Enclosure Type [kW]	A2	A3	A4	A5	B1	B2	B3	B4	C1	C2	C3	C4
200-240 V	1.1-2.2	3.0-3.7	1.1-2.2	1.1-3.7	5.5-11	15	5.5-11	15-18.5	18.5-30	37-45	22-30	37-45
380-480 V	1.1-4.0	5.5-7.5	1.1-4.0	1.1-7.5	11-18.5	22-30	11-18.5	22-37	37-55	75-90	45-55	75-90
525-600 V		1.1-7.5		1.1-7.5	11-18.5	11-30	11-18.5	22-37	37-55	37-90	45-55	75-90
Screw holes (in [mm])												
c	0.315 [8.0]	0.315 [8.0]	0.32 [8.2]	0.32 [8.2]	0.47 [12]	0.47 [12]	0.315 [8]	-	0.47 [12]	0.47 [12]	-	-
d	0.43 [11]	0.43 [11]	0.47 [12]	0.47 [12]	0.75 [19]	0.75 [19]	0.47 [12]	-	0.75 [19]	0.75 [19]	-	-
e	0.22 [5.5]	0.22 [5.5]	0.26 [6.5]	0.26 [6.5]	0.35 [9]	0.35 [9]	0.27 [6.8]	0.34 [8.5]	0.35 [9.0]	0.35 [9.0]	0.34 [8.5]	0.34 [8.5]
f	0.35 [9]	0.35 [9]	0.24 [6]	0.35 [9]	0.35 [9]	0.35 [9]	0.31 [7.9]	0.59 [15]	0.39 [9.8]	0.39 [9.8]	0.67 [17]	0.67 [17]
Max. weight (lbs [kg])	10.8 [4.9]	14.6 [6.6]	21.4 [9.7]	31 [14]	51 [23]	59.6 [27]	26.5 [12]	52 [23.5]	99.2 [45]	143.3 [65]	77.2 [35]	110.3 [50]

* See Figure 3.4 and Figure 3.5 for top and bottom mounting holes.
 ** Depth of enclosure will vary with different options installed.

Table 8.17 Power Ratings, Weight and Dimensions

9 Appendix

9.1 Symbols, Abbreviations and Conventions

AC	Alternating Current
AEO	Automatic Energy Optimization
AWG	American Wire Gauge
AMA	Automatic Motor Adaptation
°C	Degrees Celsius
DC	Direct Current
EMC	Electro Magnetic Compatibility
ETR	Electronic Thermal Relay
FC	Adjustable Frequency Drive
LCP	Local Control Panel
MCT	Motion Control Tool
IP	Ingress Protection
$I_{M,N}$	Nominal Motor Current
$f_{M,N}$	Nominal Motor Frequency
$P_{M,N}$	Nominal Motor Power
$U_{M,N}$	Nominal Motor Voltage
PM Motor	Permanent Magnet Motor
PELV	Protective Extra Low Voltage
PCB	Printed Circuit Board
PWM	Pulse Width Modulated
I_{LIM}	Current Limit
I_{INV}	Rated Inverter Output Current
RPM	Revolutions Per Minute
Regen	Regenerative Terminals
n_s	Synchronous Motor Speed
T_{LIM}	Torque Limit
$I_{VLT,MAX}$	The Maximum Output Current
$I_{VLT,N}$	The Rated Output Current Supplied by the Adjustable Frequency Drive

Table 9.1 Symbols and Abbreviations

Conventions

Numbered lists indicate procedures.

Bullet lists indicate other information and description of figures.

Italicized text indicates

- cross reference
- link
- parameter name

9.2 Parameter Menu Structure

0-0*	Operation / Display	Motor Construction	Compressor Min. Speed for Trip [Hz]	Max Output Frequency	5-68	Pulse Output Max Freq #X30/6
0-0*	Basic Settings					I/O Options
0-01	Language	1-10 VVCplus PM	1-87 Motor Temperature	4-19 Adj. Warnings	5-8*	AHF Cap Reconnect Delay
0-02	Motor Speed Unit	1-14 Damping Gain	1-90 Motor Thermal Protection	4-50 Warning Current Low	5-80	Bus Controlled
0-03	Regional Settings	1-15 Low Speed Filter Time Const.	1-91 Motor External Fan	4-51 Warning Current High	5-9*	Digital & Relay Bus Control
0-04	Operating State at Power-up	1-16 High Speed Filter Time Const.	1-93 Thermistor Source	4-52 Warning Speed Low	5-90	Pulse Out #27 Bus Control
0-05	Local Mode Unit	1-17 Voltage filter time const.	2-** Brakes	4-53 Warning Speed High	5-93	Pulse Out #29 Bus Control
0-1*	Set-up Operations	Motor Data	2-0* DC-Brake	4-54 Warning Reference Low	5-94	Pulse Out #27 Timeout Preset
0-10	Active Set-up	2-00 Motor Power [kW]	2-00 DC Hold/Preheat Current	4-55 Warning Reference High	5-95	Pulse Out #29 Timeout Preset
0-11	Programming Set-up	2-01 Motor Power [HP]	2-01 DC Brake Current	4-56 Warning Feedback Low	5-96	Pulse Out #X30/6 Bus Control
0-12	This Set-up Linked to	2-02 Motor Voltage	2-02 DC Braking Time	4-57 Warning Feedback High	5-97	Pulse Out #X30/6 Timeout Preset
0-13	Readout: Linked Set-ups	2-03 Motor Frequency	2-03 DC Brake Cut In Speed [RPM]	4-58 Missing Motor Phase Function	6-** Analog In/Out	
0-14	Readout: Prog. Set-ups / Channel	2-04 Motor Current	2-04 DC Brake Cut In Speed [Hz]	4-6* Speed Bypass	6-0*	Analog I/O Mode
0-2*	LCP Display	2-06 Motor Nominal Speed	2-06 Parking Current	4-60 Bypass Speed From [RPM]	6-00	Live Zero Timeout Time
0-20	Display Line 1.1 Small	2-07 Motor Cont. Rated Torque	2-07 Parking Time	4-61 Bypass Speed From [Hz]	6-01	Live Zero Timeout Function
0-21	Display Line 1.2 Small	2-1* Brake Energy Funct.	2-10 Brake Function	4-62 Bypass Speed To [RPM]	6-02	Fire Mode Live Zero Timeout Function
0-22	Display Line 1.3 Small	2-10 Automatic Motor Adaptation (AMA)	2-16 AC brake Max. Current	4-63 Bypass Speed To [Hz]		Function
0-23	Display Line 2 Large	Adv. Motor Data	2-17 Over-voltage Control	4-64 Semi-Auto Bypass Set-up	6-1*	Analog Input 53
0-24	Display Line 3 Large	3-0* Reference / Ramps	3-0* Reference Limits	5-0* Digital I/O mode	6-10	Terminal 53 Low Voltage
0-25	My Personal Menu	3-01 Rotor Resistance (Rr)	3-01 Minimum Reference	5-00 Digital I/O Mode	6-11	Terminal 53 High Voltage
0-30	LCP Custom Readout	3-02 Iron Loss Resistance (Rfe)	3-02 Maximum Reference	5-01 Terminal 27 Mode	6-12	Terminal 53 Low Current
0-31	Custom Readout Min Value	3-03 Motor Poles	3-04 Reference Function	5-02 Terminal 29 Mode	6-13	Terminal 53 High Current
0-32	Custom Readout Max Value	3-1* References	3-1* References	5-1* Digital Inputs	6-14	Terminal 53 Low Ref./Feedb. Value
0-37	Display Text 1	3-10 Back EMF at 1000 RPM	3-10 Preset Reference	5-10 Terminal 18 Digital Input	6-15	Terminal 53 High Ref./Feedb. Value
0-38	Display Text 2	3-11 Position Detection Gain	3-11 Jog Speed [Hz]	5-11 Terminal 19 Digital Input	6-16	Terminal 53 Filter Time Constant
0-39	Display Text 3	3-12 Load Indep. Setting	3-12 Motor Magnetising at Zero Speed	5-12 Terminal 27 Digital Input	6-17	Terminal 53 Live Zero
0-4*	LCP keypad	3-13 Min Speed Normal Magnetising [RPM]	3-13 Reference Site	5-13 Terminal 29 Digital Input	6-2*	Analog Input 54
0-40	[Hand on] Key on LCP	3-14 Slip Compensation	3-14 Preset Relative Reference	5-14 Terminal 32 Digital Input	6-20	Terminal 54 Low Voltage
0-41	[Off] Key on LCP	3-15 Min Speed Normal Magnetising [Hz]	3-15 Reference 1 Source	5-15 Terminal 33 Digital Input	6-21	Terminal 54 High Voltage
0-42	[Auto on] Key on LCP	3-16 Flystart Test Pulses Current	3-16 Reference 2 Source	5-16 Terminal X30/2 Digital Input	6-22	Terminal 54 Low Current
0-43	[Reset] Key on LCP	3-17 Flystart Test Pulses Frequency	3-17 Reference 3 Source	5-17 Terminal X30/3 Digital Input	6-23	Terminal 54 High Current
0-5*	Copy/Save	3-19 Load Depen. Setting	3-19 Jog Speed [RPM]	5-18 Terminal X30/4 Digital Input	6-24	Terminal 54 Low Ref./Feedb. Value
0-50	LCP Copy	3-4* Ramp 1	3-4* Ramp 1	5-19 Terminal 37 Safe Stop	6-25	Terminal 54 High Ref./Feedb. Value
0-51	Set-up Copy	3-41 Low Speed Load Compensation	3-41 Ramp 1 Ramp Up Time	5-3* Digital Outputs	6-26	Terminal 54 Filter Time Constant
0-52	Access to Main Menu w/o Password	3-42 High Speed Load Compensation	3-42 Ramp 1 Ramp Down Time	5-30 Terminal 27 Digital Output	6-27	Terminal 54 Live Zero
0-55	Personal Menu Password	3-5* Slip Compensation	3-5* Ramp 2	5-31 Terminal 29 Digital Output	6-3*	Analog Input X30/11
0-60	Access to Personal Menu w/o Password	3-51 Slip Compensation Time Constant	3-51 Ramp 2 Ramp Up Time	5-32 Term X30/6 Digi Out (MCB 101)	6-30	Terminal X30/11 Low Voltage
0-65	Access to Personal Menu w/o Password	3-52 Resonance Dampening	3-52 Ramp 2 Ramp Down Time	5-33 Term X30/7 Digi Out (MCB 101)	6-31	Terminal X30/11 High Voltage
0-66	Password	3-8* Constant	3-8* Other Ramps	5-4* Relays	6-34	Term. X30/11 Low Ref./Feedb. Value
0-67	Bus Password Access	3-81 Min. Current at Low Speed	3-81 Jog Ramp Time	5-40 Function Relay	6-35	Term. X30/11 High Ref./Feedb. Value
0-7*	Clock Settings	3-82 Start Adjustments	3-82 Quick Stop Ramp Time	5-41 On Delay, Relay	6-36	Term. X30/11 Filter Time Constant
0-70	Set Date and Time	3-9* PM Start Mode	3-82 Starting Ramp Up Time	5-42 Off Delay, Relay	6-37	Term. X30/11 Live Zero
0-71	Date Format	3-90 Start Delay	3-90 Step Size	5-50 Term. 29 Low Frequency	6-40	Terminal X30/12 Low Voltage
0-72	Time Format	3-91 Flying Start	3-91 Ramp Time	5-51 Term. 29 High Frequency	6-41	Terminal X30/12 High Voltage
0-74	DST/Summertime	3-92 Start Speed [RPM]	3-92 Power Restore	5-52 Term. 29 Low Ref./Feedb. Value	6-44	Term. X30/12 Low Ref./Feedb. Value
0-76	DST/Summertime Start	3-93 Start Speed [Hz]	3-93 Maximum Limit	5-53 Term. 29 High Ref./Feedb. Value	6-45	Term. X30/12 High Ref./Feedb. Value
0-77	DST/Summertime End	3-94 Start Current	3-94 Minimum Limit	5-54 Pulse Filter Time Constant #29	6-46	Term. X30/12 Filter Time Constant
0-79	Clock Fault	4-** Limits / Warnings	4-** Limits / Warnings	5-55 Term. 33 Low Frequency	6-47	Term. X30/12 Live Zero
0-81	Working Days	4-1* Motor Limits	4-1* Motor Limits	5-56 Term. 33 High Frequency	6-5*	Analog Output 42
0-82	Additional Working Days	4-10 Compressor Start Max Speed [Hz]	4-10 Motor Speed Direction	5-57 Term. 33 Low Ref./Feedb. Value	6-50	Terminal 42 Output
0-83	Additional Non-Working Days	4-11 Compressor Start Max Time to Trip	4-10 Motor Speed	5-58 Term. 33 High Ref./Feedb. Value	6-51	Terminal 42 Output Min Scale
0-89	Date and Time Readout	1-8* Stop Adjustments	4-11 Motor Speed Low Limit [RPM]	5-59 Pulse Filter Time Constant #33	6-52	Terminal 42 Output Max Scale
1-0*	General Settings	1-80 Function at Stop	4-12 Motor Speed Low Limit [RPM]	5-60 Terminal 27 Pulse Output Variable	6-53	Terminal 42 Output Bus Control
1-00	Configuration Mode	1-81 Min Speed for Function at Stop [RPM]	4-13 Motor Speed High Limit [RPM]	5-62 Pulse Output Max Freq #27	6-54	Terminal 42 Output Timeout Preset
1-03	Torque Characteristics	1-82 Min Speed for Function at Stop [Hz]	4-14 Torque Limit Motor Mode	5-63 Pulse Output Max Freq #29	6-6*	Analog Output X30/8
1-1*	Motor Selection	1-86 Compressor Min. Speed for Trip [RPM]	4-17 Torque Limit Generator Mode [RPM]	5-65 Pulse Output Max Freq #29	6-60	Terminal X30/8 Output
				5-66 Terminal X30/6 Pulse Output Variable	6-61	Terminal X30/8 Min. Scale
					6-62	Terminal X30/8 Max. Scale

6-63	Terminal X30/8 Output Bus Control	13-10	Comparator Operand	15-06	Reset kWh Counter	16-02	Reference [%]	16-9*	Diagnosis Readouts
6-64	Terminal X30/8 Output Timeout	13-11	Comparator Operator	15-07	Reset Running Hours Counter	16-03	Status Actual	16-90	Alarm Word
	Preset	13-12	Comparator Value	15-08	Number of Starts	16-05	Main Actual Value [%]	16-91	Alarm Word 2
	8-3* Comm. and Options	13-2* Timers		15-1* Data Log Settings		16-09	Custom Readout	16-92	Warning Word
8-0*	General Settings	13-20	SL Controller Timer	15-10	Logging Source	16-1*	Motor Status	16-93	Warning Word 2
8-01	Control Site	13-40	Logic Rule Boolean 1	15-11	Logging Interval	16-10	Power [kW]	16-94	Ext. Status Word
8-02	Control Source	13-40	Logic Rule Boolean 1	15-12	Trigger Event	16-11	Power [hp]	16-95	Ext. Status Word 2
8-03	Control Timeout Time	13-41	Logic Rule Operator 1	15-13	Logging Mode	16-12	Motor Voltage	16-96	Maintenance Word
8-04	Control Timeout Function	13-42	Logic Rule Boolean 2	15-14	Samples Before Trigger	16-13	Frequency	18-3*	Info & Readouts
8-05	End-of-Timeout Function	13-43	Logic Rule Operator 2	15-2*	Historic Log	16-14	Motor current	18-0*	Maintenance Log
8-06	Reset Control Timeout	13-44	Logic Rule Boolean 3	15-20	Historic Log: Event	16-15	Frequency [%]	18-00	Maintenance Log: Item
8-07	Diagnosis Trigger	13-5*	States	15-21	Historic Log: Value	16-16	Torque [Nm]	18-01	Maintenance Log: Action
8-1*	Control Settings	13-51	SL Controller Event	15-22	Historic Log: Time	16-17	Speed [RPM]	18-02	Maintenance Log: Time
8-10	Control Profile	13-52	SL Controller Action	15-23	Historic log: Date and Time	16-18	Motor Thermal	18-03	Maintenance Log: Date and Time
8-13	Configurable Status Word STW	14-3*	Special Functions	15-3*	Alarm Log	16-22	Torque [%]	18-3*	Inputs & Outputs
8-3*	FC Port Settings	14-0*	Inverter Switching	15-30	Alarm Log: Error Code	16-3*	Drive Status	18-30	Analog Input X42/1
8-30	Protocol	14-00	Switching Pattern	15-31	Alarm Log: Value	16-30	DC Link Voltage	18-31	Analog Input X42/3
8-31	Address	14-01	Switching Frequency	15-32	Alarm Log: Time	16-32	Brake Energy /s	18-32	Analog Input X42/5
8-32	Baud Rate	14-03	Overmodulation	15-33	Alarm Log: Date and Time	16-33	Brake Energy /2 min	18-33	Analog Out X42/7 [V]
8-33	Parity / Stop Bits	14-04	PWM Random	15-34	Alarm Log: Status	16-34	Heatsink Temp.	18-34	Analog Out X42/9 [V]
8-35	Minimum Response Delay	14-1*	Mains On/Off	15-35	Alarm Log: Alarm Text	16-35	Inverter Thermal	18-35	Analog Out X42/11 [V]
8-36	Maximum Response Delay	14-12	Function at Mains Imbalance	15-4*	Drive Identification	16-36	Inv. Norm. Current	20-3*	Drive Closed Loop
8-37	Maximum Inter-Char Delay	14-2*	Reset Functions	15-40	FC Type	16-37	Inv. Max. Current	20-0*	Feedback
8-4*	Adv. Protocol Set.	14-20	Reset Mode	15-41	Power Section	16-38	SL Controller State	20-01	Feedback 1 Source
8-40	Telegram Selection	14-21	Automatic Restart Time	15-42	Voltage	16-39	Control Card Temp.	20-01	Feedback 1 Conversion
8-45	BTM Transaction Command	14-22	Operation Mode	15-43	Software Version	16-40	Logging Buffer Full	20-02	Feedback 1 Source Unit
8-46	BTM Transaction Status	14-23	Typecode Setting	15-44	Ordered Typecode String	16-41	LCP Bottom Statusline	20-03	Feedback 2 Source
8-47	BTM Transaction	14-25	Trip Delay at Torque Limit	15-45	Actual Typecode String	16-49	Current Fault Source	20-04	Feedback 2 Conversion
8-5*	Digital/Bus	14-26	Trip Delay at Inverter Fault	15-46	Frequency Converter Ordering No	16-5*	Ref. & Feedsb.	20-05	Feedback 2 Source Unit
8-50	Coasting Select	14-28	Production Settings	15-47	Power Card Ordering No	16-50	External Reference	20-06	Feedback 3 Source
8-52	DC Brake Select	14-29	Service Code	15-48	LCP Id No	16-52	Feedback[Unit]	20-07	Feedback 3 Conversion
8-53	Start Select	14-3*	Current Limit Ctrl.	15-49	SW ID Control Card	16-53	Digi Pot Reference	20-08	Feedback 3 Source Unit
8-54	Reversing Select	14-30	Current Lim Ctrl, Proportional Gain	15-50	SW ID Power Card	16-54	Feedback 2 [Unit]	20-12	Reference/Feedback Unit
8-55	Setup Select	14-31	Current Lim Ctrl, Integration Time	15-51	Frequency Converter Serial Number	16-55	Feedback 2 [Unit]	20-2*	Feedback/Setpoint
8-56	Preset Reference Select	14-32	Current Lim Ctrl, Filter Time	15-53	Power Card Serial Number	16-56	Feedback 3 [Unit]	20-20	Feedback Function
8-8*	FC Port Diagnostics	14-4*	Energy Optimising	15-6*	Option Ident	16-6*	Inputs & Outputs	20-21	Setpoint 1
8-80	Bus Message Count	14-40	VT Level	15-60	Option Mounted	16-60	Digital Input	20-22	Setpoint 2
8-81	Bus Error Count	14-41	AEO Minimum Magnetisation	15-61	Option SW Version	16-61	Terminal 53 Switch Setting	20-23	Setpoint 3
8-82	Slave Message Count	14-42	Minimum AEO Frequency	15-62	Option Ordering No	16-62	Analog Input 53	20-25	Setpoint Type
8-83	Slave Error Count	14-43	Motor Cosphi	15-63	Option Serial No	16-63	Terminal 54 Switch Setting	20-3*	Feedback Adv. Conv
8-9*	Bus Jog / Feedback	14-5*	Environment	15-70	Option in Slot A	16-64	Analog Input 54	20-30	Refrigerant
8-94	Bus Feedback 1	14-50	RFI Filter	15-71	Slot A Option SW Version	16-65	Analog Output 42 [mA]	20-31	User Defined Refrigerant A1
8-95	Bus Feedback 2	14-51	DC Link Compensation	15-72	Option in Slot B	16-66	Digital Output [bin]	20-32	User Defined Refrigerant A2
8-96	Bus Feedback 3	14-52	Fan Control	15-73	Slot B Option SW Version	16-67	Pulse Input #29 [Hz]	20-33	User Defined Refrigerant A3
11-1*	LON Param. Access	11-2*	AK LonWorks	14-53	Fan Monitor	16-68	Pulse Input #33 [Hz]	20-4*	Thermostat/Pressostat
11-21	Store Data Values	14-55	Output Filter	15-75	Slot C0/E0 Option SW Version	16-69	Pulse Output #27 [Hz]	20-40	Thermostat/Pressostat Function
11-90	VLT Network Address	14-59	Actual Number of Inverter Units	15-76	Option in Slot C1/E1	16-70	Pulse Output #29 [Hz]	20-41	Cut-out Value
11-91	AK Service Pin	14-60	Function at Inverter Overload	15-8*	Operating Data II	16-71	Relay Output [bin]	20-7*	PID Autotuning
11-98	Alarm Text	14-61	Function at Inverter Overload	15-80	Fan Running Hours	16-72	Counter A	20-70	Closed Loop Type
11-99	Alarm Status	14-62	Inv. Overload Derate Current	15-81	Preset Fan Running Hours	16-75	Analog in X30/11	20-71	PID Performance
13-3*	Smart Logic	15-3*	Drive Information	15-9*	Parameter Info	16-76	Analog in X30/12	20-72	PID Output Change
13-0*	SLC Settings	15-0*	Operating Data	15-92	Defined Parameters	16-77	Analog Out X30/8 [mA]	20-73	Minimum Feedback Level
13-01	Start Event	15-00	Operating hours	15-99	Modified Parameters	16-8*	Fieldbus & FC Port	20-74	Maximum Feedback Level
13-02	Stop Event	15-01	Running Hours	16-80	Parameter Metadata	16-80	Fieldbus CTW 1	20-79	PID Autotuning
13-03	Reset SLC	15-02	kWh Counter	16-3*	Data Readouts	16-82	Fieldbus REF 1	20-8*	PID Basic Settings
13-1*	Comparators	15-03	Power Up's	16-00	General Status	16-84	Comm. Option STW	20-81	PID Normal/ Inverse Control
		15-04	Over Temp's	16-01	Reference [Unit]	16-85	FC Port CTW 1	20-82	PID Start Speed [RPM]
		15-05	Over Volts			16-86	FC Port REF 1	20-83	PID Start Speed [Hz]



20-84	On Reference Bandwidth	21-61	Ext. 3 Proportional Gain	23-3** Time-based Functions	25-44	Staging Speed [RPM]	26-63	Terminal X42/11 Bus Control
20-9* PID Controller		21-62	Ext. 3 Integral Time	23-0* Timed Actions	25-45	Staging Speed [Hz]	26-64	Terminal X42/11 Timeout Preset
20-91	PID Anti-Windup	21-63	Ext. 3 Differentiation Time	23-00	ON Time	Desdaging Speed [RPM]	28-3** Compressor Functions	
20-93	PID Proportional Gain	21-64	Ext. 3 Dif. Gain Limit	23-01	ON Action	Desdaging Speed [Hz]	28-1* Oil Return Management	
20-94	PID Integral Time	22-** Appl. Functions		23-02	OFF Time	Staging Speed [Hz]	28-10	Oil Return Management
20-95	PID Differentiation Time	22-0* Miscellaneous		23-03	OFF Action	Status	28-11	Low Speed Running Time
20-96	PID Diff. Gain Limit	22-00	External Interlock Delay	23-04	Occurrence	Pack Status	28-12	Low Speed Interval
21-1** Ext. Closed Loop		22-01	No-Flow Detection	23-1* Maintenance	25-81	Compressor Status	28-13	Boost Duration
21-0* Ext. CL Autotuning		22-02	Low Power Auto Set-up	23-10	Maintenance Item	Relay Status	28-2* Discharge Temperature Monitor	
21-00	Closed Loop Type	22-21	Low Power Detection	23-11	Maintenance Action	Compressor ON Time	28-20	Temperature Source
21-01	PID Performance	22-22	Low Speed Detection	23-12	Maintenance Time Base	Relay ON Time	28-21	Temperature Unit
21-02	PID Output Change	22-23	No-Flow Function	23-13	Maintenance Time Interval	Reset Relay Counters	28-24	Warning Level
21-03	Minimum Feedback Level	22-24	No-Flow Delay	23-14	Maintenance Date and Time	Inverse Interlock	28-25	Warning Action
21-04	Maximum Feedback Level	22-26	Dry Pump Function	23-1* Maintenance Reset	25-88	Pack capacity [%]	28-26	Emergency Level
21-09	PID Autotuning	22-27	Dry Pump Delay	23-15	Reset Maintenance Word	Service	28-27	Discharge Temperature
21-1* Ext. CL 1 Ref./Fb.		22-3* No-Flow Power Tuning		23-16	Maintenance Text	Compressor Interlock	28-7* Day/Night Settings	
21-10	Ext. 1 Ref./Feedback Unit	22-30	No-Flow Power	23-5* Energy Log	25-91	Manual Alternation	28-71	Day/Night Bus Indicator
21-11	Ext. 1 Minimum Reference	22-31	Power Correction Factor	23-50	Energy Log Resolution	26-** Analog I/O Option	28-72	Enable Day/Night Via Bus
21-12	Ext. 1 Maximum Reference	22-32	Low Speed [RPM]	23-51	Period Start	26-0* Analog I/O Mode	28-73	Night Setback
21-13	Ext. 1 Reference Source	22-33	Low Speed [Hz]	23-53	Energy Log	Terminal X42/1 Mode	28-74	Night Speed Drop [RPM]
21-14	Ext. 1 Feedback Source	22-34	Low Speed Power [kW]	23-54	Reset Energy Log	Terminal X42/3 Mode	28-75	Night Speed Drop Override
21-15	Ext. 1 Setpoint	22-35	Low Speed Power [HP]	23-6* Trending	26-02	Terminal X42/5 Mode	28-76	Night Speed Drop [Hz]
21-17	Ext. 1 Reference [Unit]	22-36	High Speed [Hz]	23-60	Trend Variable	26-1* Analog Input X42/1	28-8* P0 Optimization	
21-18	Ext. 1 Feedback [Unit]	22-37	High Speed [Hz]	23-61	Continuous Bin Data	Terminal X42/1 Low Voltage	28-81	dP0 Offset
21-19	Ext. 1 Output [%]	22-38	High Speed Power [kW]	23-62	Timed Bin Data	Terminal X42/1 High Voltage	28-82	P0
21-2* Ext. CL 1 PID		22-39	High Speed Power [HP]	23-63	Timed Period Start	Term. X42/1 Low Ref./Feedb. Value	28-83	P0 Setpoint
21-20	Ext. 1 Normal/Inverse Control	22-4* Sleep Mode		23-64	Timed Period Stop	Term. X42/1 High Ref./Feedb. Value	28-84	P0 Reference
21-21	Ext. 1 Proportional Gain	22-40	Minimum Run Time	23-65	Minimum Bin Value	Term. X42/1 Filter Time Constant	28-85	P0 Minimum Reference
21-22	Ext. 1 Integral Time	22-41	Minimum Sleep Time	23-66	Reset Continuous Bin Data	Term. X42/1 Live Zero	28-86	P0 Maximum Reference
21-23	Ext. 1 Differentiation Time	22-42	Wake-up Speed [RPM]	23-67	Reset Timed Bin Data	26-2* Analog Input X42/3	28-87	Most Loaded Controller
21-24	Ext. 1 Dif. Gain Limit	22-43	Wake-up Speed [Hz]	23-8* Payback Counter	26-20	Terminal X42/3 Low Voltage	28-9* Injection Control	
21-3* Ext. CL 2 Ref./Fb.		22-44	Wake-up Ref./FB Difference	23-80	Power Reference Factor	Terminal X42/3 High Voltage	28-90	Injection On
21-30	Ext. 2 Ref./Feedback Unit	22-45	Setpoint Boost	23-81	Energy Cost	Term. X42/3 Low Ref./Feedb. Value	28-91	Delayed Compressor Start
21-31	Ext. 2 Minimum Reference	22-46	Maximum Boost Time	23-82	Investment	Term. X42/3 High Ref./Feedb. Value	30-3** Special Features	
21-32	Ext. 2 Maximum Reference	22-5* End of Curve		23-83	Energy Savings	Term. X42/3 Filter Time Constant	30-2* Adv. Start Adjust	
21-33	Ext. 2 Reference Source	22-50	End of Curve Function	23-84	Cost Savings	Term. X42/3 Live Zero	30-22	Locked Rotor Protection
21-34	Ext. 2 Feedback Source	22-51	End of Curve Delay	25-5* Pack Controller	26-3* Analog Input X42/5	Terminal X42/5 Low Voltage	30-23	Locked Rotor Detection Time [s]
21-35	Ext. 2 Setpoint	22-6* Broken Belt Detection		25-0* System Settings	26-30	Terminal X42/5 Low Voltage		
21-37	Ext. 2 Reference [Unit]	22-60	Broken Belt Function	25-00	Pack Controller	Terminal X42/5 High Voltage		
21-38	Ext. 2 Feedback [Unit]	22-61	Broken Belt Torque	25-04	Compressor Cycling	Term. X42/5 Low Ref./Feedb. Value		
21-39	Ext. 2 Output [%]	22-62	Broken Belt Delay	25-06	Number of Compressors	Term. X42/5 High Ref./Feedb. Value		
21-4* Ext. CL 2 PID		22-7* Short Cycle Protection		25-2* Zone Settings	26-36	Term. X42/5 Filter Time Constant		
21-40	Ext. 2 Normal/Inverse Control	22-75	Short Cycle Protection	25-20	Neutral Zone [unit]	Term. X42/5 Live Zero		
21-41	Ext. 2 Proportional Gain	22-76	Interval between Starts	25-21	+ Zone [unit]	26-4* Analog Out X42/7		
21-42	Ext. 2 Integral Time	22-77	Minimum Run Time	25-22	- Zone [unit]	Terminal X42/7 Output		
21-43	Ext. 2 Differentiation Time	22-78	Minimum Run Time Override	25-23	Fixed Speed neutral Zone [unit]	Terminal X42/7 Min. Scale		
21-44	Ext. 2 Dif. Gain Limit	22-79	Minimum Run Time Override Value	25-24	+ Zone Delay	Terminal X42/7 Max. Scale		
21-5* Ext. CL 3 Ref./Fb.		22-8* Flow Compensation		25-25	- Zone Delay	Terminal X42/7 Bus Control		
21-50	Ext. 3 Ref./Feedback Unit	22-80	Flow Compensation	25-26	+ Zone Delay	Terminal X42/7 Timeout Preset		
21-51	Ext. 3 Minimum Reference	22-81	Square-linear Curve Approximation	25-27	- Zone Delay	26-5* Analog Out X42/9		
21-52	Ext. 3 Maximum Reference	22-82	Work Point Calculation	25-3* Staging Functions	26-50	Terminal X42/9 Output		
21-53	Ext. 3 Reference Source	22-83	Speed at No-Flow [RPM]	25-30	Stage At No-Flow	Terminal X42/9 Min. Scale		
21-54	Ext. 3 Feedback Source	22-84	Speed at No-Flow [Hz]	25-31	Stage Function	Terminal X42/9 Max. Scale		
21-55	Ext. 3 Setpoint	22-85	Speed at Design Point [RPM]	25-32	Stage Function Time	Terminal X42/9 Bus Control		
21-57	Ext. 3 Reference [Unit]	22-86	Speed at Design Point [Hz]	25-33	Stage Function	Terminal X42/9 Timeout Preset		
21-58	Ext. 3 Feedback [Unit]	22-87	Pressure at No-Flow Speed	25-34	Destage Function Time	26-6* Analog Out X42/11		
21-59	Ext. 3 Output [%]	22-88	Pressure at Rated Speed	25-4* Staging Thresholds	26-60	Terminal X42/11 Output		
21-6* Ext. CL 3 PID		22-89	Flow at Design Point	25-42	Staging Threshold	Terminal X42/11 Min. Scale		
21-60	Ext. 3 Normal/Inverse Control	22-90	Flow at Rated Speed	25-43	Destaging Threshold	Terminal X42/11 Max. Scale		

Index

A

Abbreviations..... 69

AC input..... 7, 18

AC line power..... 7, 18

AC line voltage..... 24, 36

AC waveform..... 7

Additional Resources..... 4

AEO..... 29

Alarm log..... 25

Alarms..... 38

AMA..... 30, 36, 40, 43

Analog input..... 19, 39

Analog output..... 19

Analog signal..... 39

Approvals..... 7

Auto on..... 25, 31

Auto On..... 36, 38

Auto-reset..... 24

Auxiliary equipment..... 22

B

Backplate..... 11

Brake control..... 40

Brake resistor..... 39

C

Cable routing..... 22

Certifications..... 7

Circuit breakers..... 22, 60

Clearance requirements..... 11

Closed-loop..... 21

Communication option..... 42

Conduit..... 22

Control card..... 39

Control card, USB serial communication..... 59

Control signal..... 36

Control terminal..... 25, 28

Control terminals..... 36, 38

Control wiring..... 13, 16, 20, 22

Control word timeout..... 41

Conventions..... 69

Cooling..... 11

Cooling clearance..... 22

Current limit..... 46

Current rating..... 40

D

DC current..... 7, 13, 37

DC link..... 39

Default setting..... 26

Digital input..... 20, 37, 40

Dimensions..... 67

Discharge time..... 9

Disconnect switch..... 23

Disposal instruction..... 7

E

Electrical interference..... 14

EMC..... 13

EMC interference..... 16

Exploded View..... 5

External commands..... 7, 38

External controllers..... 4

External interlock..... 20

F

Fault log..... 25

Feedback..... 21, 22, 37, 42, 44

Floating delta..... 18

Fuse..... 13, 42

Fuses..... 22, 45, 60

G

Ground connections..... 22

Ground wire..... 13

Grounded delta..... 18

Grounding..... 17, 18, 22, 23

H

Hand On..... 25

Harmonics..... 7

Heatsink..... 42

High voltage..... 8, 23, 36

I

IEC 61800-3..... 18

Initialization.....	27	Mounting.....	11, 22
Input current.....	18	Multiple adjustable frequency drives.....	13
Input disconnect.....	18	N	
Input power.....	7, 13, 16, 18, 22, 23, 38, 45	Nameplate.....	10
Input power wiring.....	22	Navigation key.....	24, 25, 27
Input signal.....	21	Navigation keys.....	36
Input terminal.....	18, 21, 23, 39	O	
Input voltage.....	23	Open-loop.....	21
Installation.....	20, 21, 22	Operation key.....	24
Installation Environments.....	10	Optional equipment.....	18, 20, 23
Intended Use.....	4	Output current.....	36, 40
Interference isolation.....	22	Output power wiring.....	22
Intermediate Circuit.....	39	Output terminal.....	23
Isolated line power.....	18	Overcurrent protection.....	13
J		Overheating.....	40
Jumper.....	20	Overtemperature.....	40
L		Overvoltage.....	37, 46
Leakage current.....	9, 13	P	
Lifting.....	11	Parameter Menu Structure.....	70
Local control.....	24, 25, 36	Phase loss.....	39
Local control panel (LCP).....	24	PM Motor.....	28
M		Potential equalization.....	14
Main menu.....	25	Power connection.....	13
Maintenance.....	36	Power factor.....	7, 22
Manual initialization.....	27	Power Ratings.....	67
MCT 10.....	19, 24	Programming.....	20, 24, 25, 26, 39
Menu key.....	24, 25	Q	
Menu structure.....	25	Qualified personnel.....	8
Modbus RTU.....	21	Quick menu.....	24, 25
Motor cable.....	13	R	
Motor cables.....	0, 17	Ramp-down time.....	46
Motor current.....	7, 24, 30, 43	Ramp-up time.....	46
Motor data.....	28, 30, 40, 43, 46	Reference.....	24, 32, 36, 37
Motor output.....	55	Remote commands.....	4
Motor power.....	13, 24, 43	Remote reference.....	37
Motor protection.....	4	Reset.....	24, 25, 27, 38, 40, 44
Motor rotation.....	30	RFI filter.....	18
Motor speed.....	27	RMS current.....	7
Motor status.....	4	RS-485 serial communication.....	21
Motor wiring.....	16, 22		

Index	Instruction Manual
Run command.....	31
Run permissive.....	37
S	
Safe Torque Off.....	21
Serial communication.....	19, 25, 36, 37, 38
Service.....	36
Setpoint.....	37
Set-up.....	25, 31
Shielded cable.....	16, 22
Shock.....	10
Short circuit.....	41
Sleep Mode.....	38
Specifications.....	21
Speed reference.....	21, 31, 36
Start-up.....	27
Status mode.....	36
Storage.....	10
Supply voltage.....	18, 19, 23, 42
Switch.....	21
Switching frequency.....	37
Symbols.....	69
System feedback.....	4
T	
Terminal 53.....	21
Terminal 54.....	21
Thermal protection.....	7
Thermistor.....	18
Thermistor control wiring.....	18
Tightening of Terminals.....	59
Torque.....	40
Torque characteristics.....	55
Torque limit.....	46
Transient protection.....	7
Trip lock.....	38
Trips.....	38
U	
Unintended start.....	8, 23
V	
Vibration.....	10
Voltage imbalance.....	39
Voltage level.....	56
VVCplus.....	28
W	
Warnings.....	38
Weight.....	67
Windmilling.....	9
Wire size.....	13
Wire sizes.....	17
Wiring schematic.....	15



www.danfoss.com/drives

.....
Danfoss shall not be responsible for any errors in catalogs, brochures or other printed material. Danfoss reserves the right to alter its products at any time without notice, provided that alterations to products already on order shall not require material changes in specifications previously agreed upon by Danfoss and the Purchaser. All trademarks in this material are property of the respective companies. Danfoss and the Danfoss logotype are trademarks of Danfoss A/S. All rights reserved.
.....

Danfoss A/S
Ulsnaes 1
DK-6300 Graasten
www.danfoss.com/drives

