



Programming Guide

VLT[®] Refrigeration Drive FC 103



Contents

1 Introduction	4
1.1 Definitions	5
1.1.1 Frequency Converter	5
1.1.2 Input	5
1.1.3 Motor	5
1.1.4 References	6
1.1.5 Miscellaneous	6
1.2 Safety	8
1.3 Electrical Wiring	10
2 How to Program	13
2.1 Local Control Panel	13
2.1.1 How to Operate Graphical LCP (GLCP)	13
2.1.2 Quick Transfer of Parameter Settings between Multiple Frequency Converters	17
2.1.3 Parameter Set-Up	17
2.1.4 Quick Menu Mode	17
2.1.5 Function Set-ups	19
2.1.6 Main Menu Mode	21
2.1.7 Parameter Selection	21
2.1.8 Changing Data	22
2.1.9 Changing a Text Value	22
2.1.10 Changing a Group of Numeric Data Values	22
2.1.11 Value, Step-by-step	22
2.1.12 Read out and Programming of Indexed Parameters	22
2.1.13 Initialization to Default Settings	22
3 Parameter Description	24
3.1 Parameter Selection	24
3.1.1 Main Menu Structure	24
3.2 Parameters: 0-** Operation and Display	24
3.3 Parameters: 1-** Load and Motor	36
3.4 Parameters: 2-** Brakes	53
3.5 Parameters: 3-** Reference/Ramps	55
3.6 Parameters: 4-** Limits/Warnings	61
3.7 Parameters: 5-** Digital In/Out	65
3.8 Parameters: 6-** Analog In/Out	79
3.9 Parameters: 8-** Communications and Options	87
3.10 Parameters: 11-** FC 103 LON	94
3.11 Parameters: 13-** Smart Logic	94
3.12 Parameters: 14-** Special Functions	106

3.13 Parameters: 15-** Frequency Converter Information	113
3.14 Parameters: 16-** Data Readouts	118
3.15 Parameters: 18-** Data Readouts 2	125
3.16 Parameters: 20-** FC Closed Loop	127
3.17 Parameters: 21-** Extended Closed Loop	137
3.18 Parameters: 22-** Application Functions	145
3.19 Parameters: 23-** Time-based Functions	159
3.20 Parameters: 25-** Pack Controller	170
3.21 Parameters: 26-** Analog I/O Option MCB 109	180
3.22 Parameters: 28-** Compressor Functions	187
3.23 Parameters: 29-** Application Functions	191
3.24 Parameters: 30-** Special Features	192
4 Parameter Lists	196
4.1 Parameter Options	196
4.1.1 Default Settings	196
4.1.2 0-** Operation and Display	197
4.1.3 1-** Load/Motor	198
4.1.4 2-** Brakes	199
4.1.5 3-** Reference/Ramps	200
4.1.6 4-** Limits/Warnings	201
4.1.7 5-** Digital In/Out	201
4.1.8 6-** Analog In/Out	203
4.1.9 8-** Communication and Options	204
4.1.10 11-** FC 103 LON	205
4.1.11 13-** Smart Logic Controller	205
4.1.12 14-** Special Functions	206
4.1.13 15-** FC Information	207
4.1.14 16-** Data Readouts	208
4.1.15 18-** Info & Readouts	210
4.1.16 20-** FC Closed Loop	210
4.1.17 21-** Ext. Closed Loop	211
4.1.18 22-** Application Functions	212
4.1.19 23-** Time Based Functions	214
4.1.20 25-** Pack Controller	214
4.1.21 26-** Analog I/O Option MCB 109	216
4.1.22 28-** Compressor Functions	217
4.1.23 29-** Compressor Functions 2	217
4.1.24 30-** Special Features	218
5 Troubleshooting	219

5.1 Status Messages	219
5.1.1 Alarms and Warnings	219
5.1.2 Alarm Words	222
5.1.3 Warning Words	223
5.1.4 Extended Status Words	224
5.1.5 Fault Messages	225
Index	229

1 Introduction

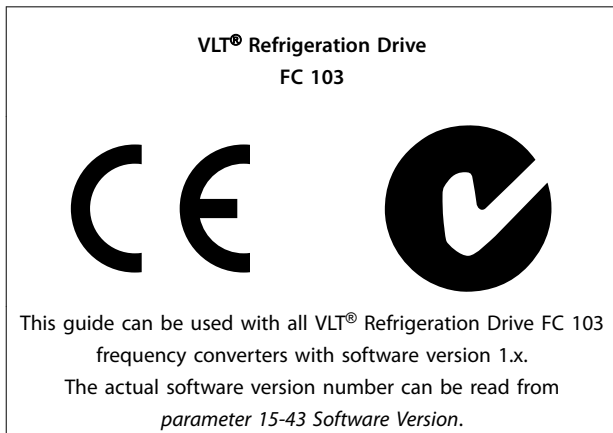

Table 1.1 Software Version

The following symbols are used in this manual.

⚠ WARNING

Indicates a potentially hazardous situation which could result in death or serious injury.

⚠ CAUTION

Indicates a potentially hazardous situation which could result in minor or moderate injury. It may also be used to alert against unsafe practices.

NOTICE

Indicates important information, including situations that may result in damage to equipment or property.

60° AVM	60° asynchronous vector modulation
A	Ampere/AMP
AC	Alternating current
AD	Air discharge
AEO	Automatic energy optimization
AI	Analog input
AIC	Ampere interrupting current
AMA	Automatic motor adaptation
AWG	American wire gauge
°C	Degrees Celsius
CB	Circuit breaker
CD	Constant discharge
CDM	Complete drive module: The frequency converter, feeding section, and auxiliaries
CE	European Conformity (European safety standards)
CM	Common mode
CT	Constant torque
DC	Direct current
DI	Digital input

DM	Differential mode
D-TYPE	Drive dependent
EMC	Electromagnetic compatibility
EMF	Electromotive force
ETR	Electronic thermal relay
°F	Degrees Fahrenheit
f _{JOG}	Motor frequency when jog function is activated
f _M	Motor frequency
f _{MAX}	Maximum output frequency, the frequency converter applies on its output
f _{MIN}	Minimum motor frequency from the frequency converter
f _{M,N}	Nominal motor frequency
FC	Frequency converter
Hiperface®	Hiperface® is a registered trademark by Stegmann
HO	High overload
hp	Horse power
HTL	HTL encoder (10–30 V) pulses - High-voltage transistor logic
Hz	Hertz
I _{INV}	Rated inverter output current
I _{LIM}	Current limit
I _{M,N}	Nominal motor current
I _{VLT,MAX}	Maximum output current
I _{VLT,N}	Rated output current supplied by the frequency converter
kHz	Kilohertz
LCP	Local control panel
lsb	Least significant bit
m	Meter
mA	Milliampere
MCM	Mille circular mil
MCT	Motion control tool
mH	Inductance in milli Henry
mm	Millimeter
ms	Millisecond
msb	Most significant bit
η _{VLT}	Efficiency of the frequency converter defined as ratio between power output and power input
nF	Capacitance in nano Farad
NLCP	Numerical local control panel
Nm	Newton meter
NO	Normal overload
n _s	Synchronous motor speed
Online/ Offline Parameters	Changes to online parameters are activated immediately after the data value is changed
P _{br,cont.}	Rated power of the brake resistor (average power during continuous braking)
PCB	Printed circuit board
PCD	Process data

PDS	Power drive system: A CDM and a motor
PELV	Protective extra low voltage
P_m	Frequency converter nominal output power as high overload (HO)
$P_{M,N}$	Nominal motor power
PM motor	Permanent magnet motor
Process PID	PID (proportional integrated differential) regulator that maintains the speed, pressure, temperature, and so on
$R_{br,nom}$	Nominal resistor value that ensures a brake power on the motor shaft of 150/160% for 1 minute
RCD	Residual current device
Regen	Regenerative terminals
R_{min}	Minimum permissible brake resistor value by frequency converter
RMS	Root mean square
RPM	Revolutions per minute
R_{rec}	Recommended brake resistor resistance of Danfoss brake resistors
s	Second
SCCR	Short circuit current rating
SFAVM	Stator flux-oriented asynchronous vector modulation
STW	Status word
SMPS	Switch mode power supply
THD	Total harmonic distortion
T_{lim}	Torque limit
TTL	TTL encoder (5 V) pulses - transistor transistor logic
$U_{M,N}$	Nominal motor voltage
UL	Underwriters Laboratories (US organization for the safety certification)
V	Volts
VT	Variable torque
VVC ⁺	Voltage vector control plus

Table 1.2 Abbreviations

Conventions

Numbered lists indicate procedures.

Bullet lists indicate other information and description of illustrations.

Italicized text indicates:

- Cross-reference.
- Link.
- Footnote.
- Parameter name, parameter group name, parameter option.

All dimensions in drawings are in mm (in).

* Indicates a default setting of a parameter.

- *VLT® Refrigeration Drive FC 103 Operating Instructions* provides information on mechanical

and electrical installation of the frequency converter.

- *VLT® Refrigeration Drive FC 103 Design Guide* holds all technical information about the frequency converter, customer design, and applications.
- *VLT® Refrigeration Drive FC 103 Programming Guide* provides information on how to program and includes complete parameter descriptions.
- *MCT 10 Set-up Software Operating Instructions* enables the user to configure the frequency converter from a Windows™-based PC environment.
- *VLT® HVAC Drive FC 102/VLT® AQUA Drive FC 202 Metasys N2, Operating Instructions*.

1.1 Definitions

1.1.1 Frequency Converter

$I_{VLT,MAX}$
Maximum output current.

$I_{VLT,N}$
Rated output current supplied by the frequency converter.

$U_{VLT,MAX}$
Maximum output voltage.

1.1.2 Input

Control command

Start and stop the connected motor with LCP and digital inputs.

Functions are divided into 2 groups.

Functions in group 1 have higher priority than functions in group 2.

Group 1	Reset, coast stop, reset and coast stop, quick stop, DC brake, stop, the [OFF] key.
Group 2	Start, pulse start, reversing, start reversing, jog, freeze output.

Table 1.3 Function Groups

1.1.3 Motor

Motor running

Torque generated on output shaft and speed from 0 RPM to maximum speed on motor.

f_{jog}
Motor frequency when the jog function is activated (via digital terminals).

f_M
Motor frequency.

f_{MAX}
Maximum motor frequency.

f_{MIN}

Minimum motor frequency.

f_{M,N}

Rated motor frequency (nameplate data).

I_M

Motor current (actual).

I_{M,N}

Rated motor current (nameplate data).

n_{M,N}

Nominal motor speed (nameplate data).

n_s

Synchronous motor speed.

$$n_s = \frac{2 \times \text{par. 1} - 23 \times 60 \text{ s}}{\text{par. 1} - 39}$$

n_{slip}

Motor slip.

P_{M,N}

Rated motor power (nameplate data in kW or hp).

T_{M,N}

Rated torque (motor).

U_M

Instant motor voltage.

U_{M,N}

Rated motor voltage (nameplate data).

Break-away torque

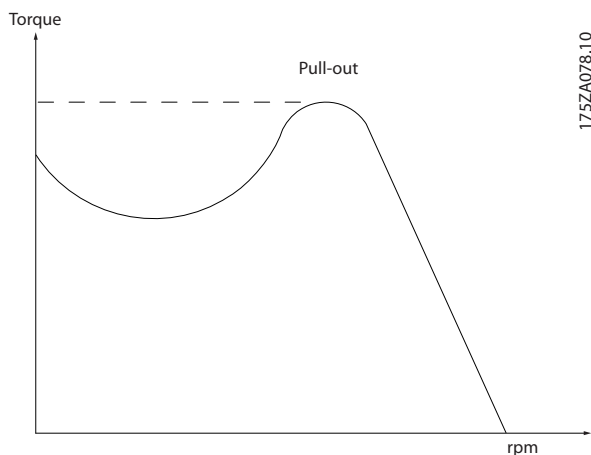

Illustration 1.1 Break-away Torque

η_{VLT}

The efficiency of the frequency converter is defined as the ratio between the power output and the power input.

Start-disable command

A stop command belonging to Group 1 control commands - see Table 1.3.

Stop command

A stop command belonging to Group 1 control commands - see Table 1.3.

1.1.4 References

Analog reference

A signal transmitted to the analog inputs 53 or 54 (voltage or current).

Binary reference

A signal transmitted to the serial communication port.

Preset reference

A defined preset reference to be set from -100% to +100% of the reference range. Selection of 8 preset references via the digital terminals.

Pulse reference

A pulse frequency signal transmitted to the digital inputs (terminal 29 or 33).

Ref_{MAX}

Determines the relationship between the reference input at 100% full scale value (typically 10 V, 20 mA) and the resulting reference. The maximum reference value is set in parameter 3-03 Maximum Reference.

Ref_{MIN}

Determines the relationship between the reference input at 0% value (typically 0 V, 0 mA, 4 mA) and the resulting reference. The minimum reference value is set in parameter 3-02 Minimum Reference.

1.1.5 Miscellaneous

Analog inputs

The analog inputs are used for controlling various functions of the frequency converter.

There are 2 types of analog inputs:
Current input, 0–20 mA, and 4–20 mA
Voltage input, -10 V DC to +10 V DC.

Analog outputs

The analog outputs can supply a signal of 0–20 mA, 4–20 mA.

Automatic motor adaptation, AMA

AMA algorithm determines the electrical parameters for the connected motor at standstill.

CT characteristics

Constant torque characteristics used for all applications such as conveyor belts, displacement pumps, and cranes.

Digital inputs

The digital inputs can be used for controlling various functions of the frequency converter.

Digital outputs

The frequency converter features 2 solid-state outputs that can supply a 24 V DC (maximum 40 mA) signal.

DSP

Digital signal processor.

ETR

Electronic thermal relay is a thermal load calculation based on present load and time. Its purpose is to estimate the motor temperature.

Hiperface®

Hiperface® is a registered trademark by Stegmann.

Initializing

If initializing is carried out (*parameter 14-22 Operation Mode*), the frequency converter returns to the default setting.

Intermittent duty cycle

An intermittent duty rating refers to a sequence of duty cycles. Each cycle consists of an on-load and an off-load period. The operation can be either periodic duty or non-periodic duty.

LCP

The local control panel makes up a complete interface for control and programming of the frequency converter. The control panel is detachable and can be installed up to 3 m (10 ft) from the frequency converter, that is, in a front panel with the installation kit option.

NLCP

Numerical local control panel interface for control and programming of the frequency converter. The display is numerical and the panel is used to show process values. The NLCP has no storage and copy functions.

lsb

Least significant bit.

msb

Most significant bit.

MCM

Short for mille circular mil, an American measuring unit for cable cross-section. 1 MCM=0.5067 mm².

Online/offline parameters

Changes to online parameters are activated immediately after the data value is changed. Press [OK] to activate changes to off-line parameters.

Process PID

The PID control maintains the required speed, pressure, temperature, and so on, by adjusting the output frequency to match the varying load.

PCD

Process control data.

Power cycle

Switch off the mains until display (LCP) is dark – then turn power on again.

Pulse input/incremental encoder

An external, digital pulse transmitter used for feeding back information on motor speed. The encoder is used in applications where great accuracy in speed control is required.

RCD

Residual current device.

Set-up

Save parameter settings in 4 set-ups. Change between the 4 parameter set-ups and edit 1 set-up, while another set-up is active.

SFAVM

Switching pattern called stator flux-oriented asynchronous vector modulation (*parameter 14-00 Switching Pattern*).

Slip compensation

The frequency converter compensates for the motor slip by giving the frequency a supplement that follows the measured motor load keeping the motor speed almost constant.

SLC

The SLC (smart logic control) is a sequence of user-defined actions executed when the associated user-defined events are evaluated as true by the SLC. (See *chapter 3.11 Parameters: 13-** Smart Logic*).

STW

Status word.

FC standard bus

Includes RS485 bus with FC protocol or MC protocol. See *parameter 8-30 Protocol*.

THD

Total harmonic distortion states the total contribution of harmonic.

Thermistor

A temperature-dependent resistor placed on the frequency converter or the motor.

Trip

A state entered in fault situations, for example if the frequency converter is subject to an overtemperature or when the frequency converter is protecting the motor, process, or mechanism. The frequency converter prevents a restart until the cause of the fault has disappeared. To cancel the trip state, restart the frequency converter. Do not use the trip state for personal safety.

Trip lock

The frequency converter enters this state in fault situations to protect itself. The frequency converter requires physical intervention, for example when there is a short circuit on the output. A trip lock can only be canceled by disconnecting mains, removing the cause of the fault, and reconnecting the frequency converter. Restart is prevented until the trip state is canceled by activating reset or, sometimes, by being programmed to reset automatically. Do not use the trip lock state for personal safety.

VT characteristics

Variable torque characteristics used for pumps and fans.

VVC+

If compared with standard voltage/frequency ratio control, voltage vector control (VVC+) improves the dynamics and the stability, both when the speed reference is changed and in relation to the load torque.

60° AVM

60° asynchronous vector modulation (parameter 14-00 Switching Pattern).

Power factor

The power factor is the relation between I_1 and I_{RMS} .

$$\text{Power factor} = \frac{\sqrt{3} \times U \times I_1 \cos\phi}{\sqrt{3} \times U \times I_{RMS}}$$

The power factor for 3-phase control:

$$\text{Power factor} = \frac{I_1 \times \cos\phi_1}{I_{RMS}} = \frac{I_1}{I_{RMS}} \text{ since } \cos\phi_1 = 1$$

The power factor indicates to which extent the frequency converter imposes a load on the mains supply.

The lower the power factor, the higher the I_{RMS} for the same kW performance.

$$I_{RMS} = \sqrt{I_1^2 + I_5^2 + I_7^2 + \dots + I_n^2}$$

In addition, a high-power factor indicates that the different harmonic currents are low.

The DC coils in the frequency converters produce a high-power factor, which minimizes the imposed load on the mains supply.

Target position

The final target position specified by positioning commands. The profile generator uses this position to calculate the speed profile.

Commanded position

The actual position reference calculated by the profile generator. The frequency converter uses the commanded position as setpoint for position PI.

Actual position

The actual position from an encoder, or a value that the motor control calculates in open loop. The frequency converter uses the actual position as feedback for position PI.

Position error

Position error is the difference between the actual position and the commanded position. The position error is the input for the position PI controller.

Position unit

The physical unit for position values.

1.2 Safety

⚠ WARNING

DISCHARGE TIME

The frequency converter contains DC-link capacitors, which can remain charged even when the frequency converter is not powered. High voltage can be present even when the warning indicator lights are off. Failure to wait the specified time after power has been removed before performing service or repair work, could result in death or serious injury.

1. Stop the motor.
2. Disconnect AC mains, permanent magnet type motors, and remote DC-link power supplies, including battery back-ups, UPS, and DC-link connections to other frequency converters.
3. Wait for the capacitors to discharge fully, before performing any service or repair work. The duration of waiting time is specified in Table 1.4.

Voltage [V]	Minimum waiting time (minutes)		
	4	7	15
200–240	0.25–3.7 kW (0.34–5 hp)	–	5.5–37 kW (7.5–50 hp)
380–500	0.25–7.5 kW (0.34–10 hp)	–	11–75 kW (15–100 hp)
525–600	0.75–7.5 kW (1–10 hp)	–	11–75 kW (15–100 hp)
525–690	–	1.5–7.5 kW (2–10 hp)	11–75 kW (15–100 hp)

Voltage [V]	Power	Minimum waiting time (minutes)
380–500	90–250 kW (125–350 hp)	20
	315–800 kW (450–1075 hp)	40
525–690	55–315 kW (frame size D) (75–450 hp)	20
	355–1200 kW (475–1600 hp)	30

Table 1.4 Discharge Time

Safety regulations

- Disconnect mains supply to the frequency converter whenever repair work is to be carried out. Check that the mains supply has been disconnected and that the necessary time has elapsed before removing motor and mains supply

plugs. For information about the discharge time, see *Table 1.4*.

- [Off] does not disconnect the mains supply and must not be used as a safety switch.
- Ground the equipment properly, protect the user against supply voltage, and protect the motor against overload in accordance with applicable national and local regulations.
- The ground leakage current exceeds 3.5 mA. Ensure correct grounding of the equipment by a certified electrical installer.
- Do not remove the plugs for the motor and mains supply while the frequency converter is connected to mains. Check that the mains supply has been disconnected and that the necessary time has elapsed before removing motor and mains plugs.
- The frequency converter has more voltage sources than L1, L2, and L3, when load sharing (linking of DC intermediate circuit) or external 24 V DC is installed. Check that all voltage sources have been disconnected and that the necessary time has elapsed before commencing repair work. For information about the discharge time, see *Table 1.4*.

NOTICE

When using the Safe Torque Off, always follow the instructions in *VLT® Frequency Converters - Safe Torque Off Operating Instructions*.

NOTICE

Control signals from, or internally within, the frequency converter may in rare cases be activated in error, be delayed, or fail to occur entirely. When used in situations where safety is critical, for example, when controlling the electromagnetic brake function of a hoist application, these control signals must not be relied on exclusively.

NOTICE

Hazardous situations must be identified by the machine builder/integrator who is responsible for considering the necessary preventive means. More monitoring and protective devices may be included, always according to valid national safety regulations, for example, law on mechanical tools and regulations for the prevention of accidents.

Protection mode

Once a hardware limit on motor current or DC-link voltage is exceeded, the frequency converter enters the protection mode. Protection mode means a change of the PWM modulation strategy and a low switching frequency to minimize losses. This continues for 10 s after the last fault and increases the reliability and the robustness of the frequency converter while re-establishing full control of the motor.

Protection mode can be disabled by setting *parameter 14-26 Trip Delay at Inverter Fault* to 0, which means that the frequency converter trips immediately if 1 of the hardware limits is exceeded.

NOTICE

Disabling protection mode in hoisting applications (*parameter 14-26 Trip Delay at Inverter Fault = 0*) is recommended.

1.3 Electrical Wiring

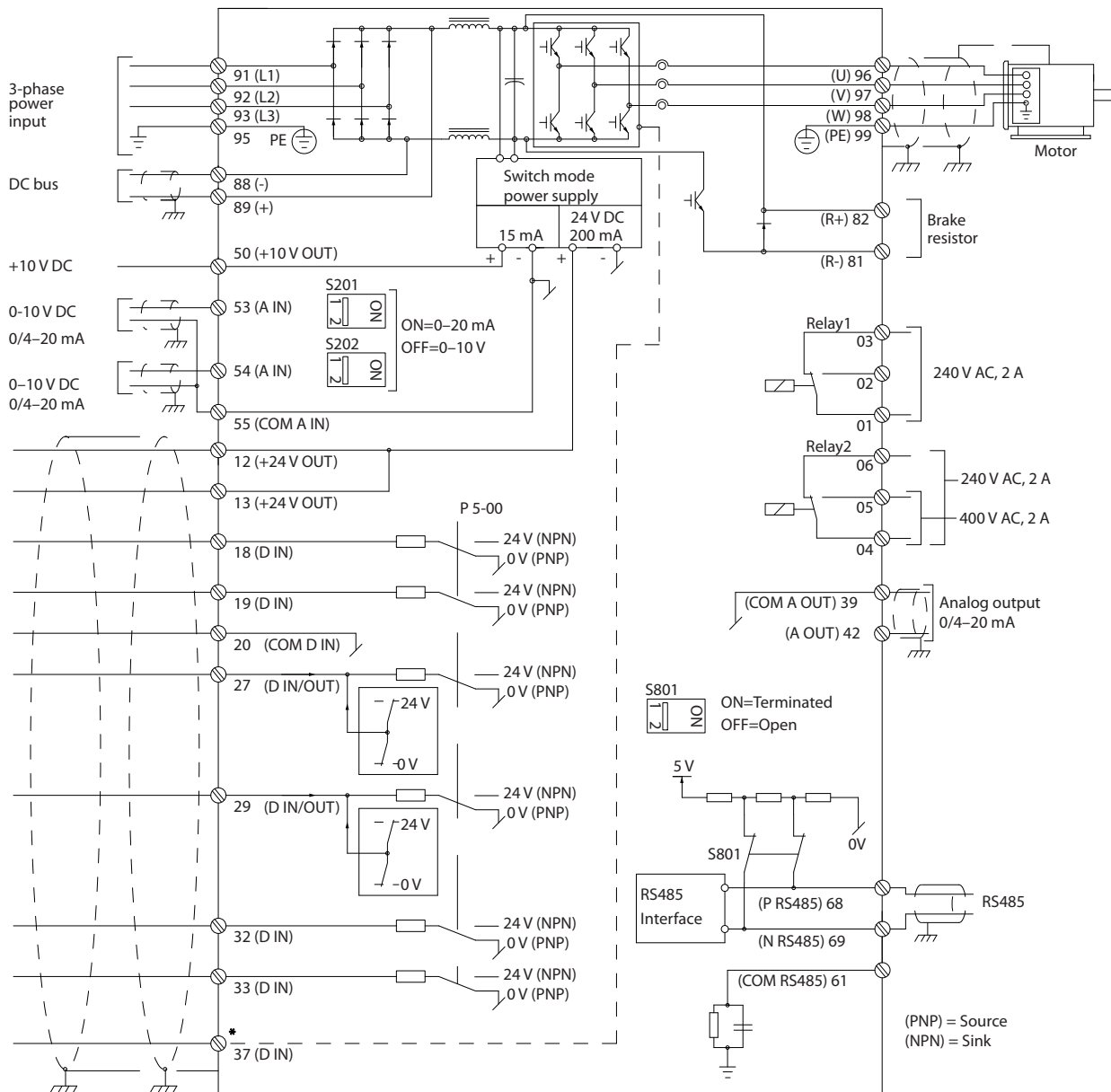

130BA544.13

Illustration 1.2 Basic Wiring Schematic Drawing

A=Analog, D=Digital

Terminal 37 is used for Safe Torque Off. For Safe Torque Off installation instructions, refer to the *VLT® Frequency Converters - Safe Torque Off Operating Instructions*.

Very long control cables and analog signals may in rare cases, and depending on installation, result in 50/60 Hz ground loops due to noise from mains supply cables.

If this occurs, it may be necessary to break the shield or insert a 100 nF capacitor between shield and enclosure.

Connect the digital and analog inputs and outputs separately to the common inputs (terminals 20, 55, and 39) of the frequency converter to avoid ground currents from both groups to affect other groups. For example, switching on the digital input may disturb the analog input signal.

Input polarity of control terminals

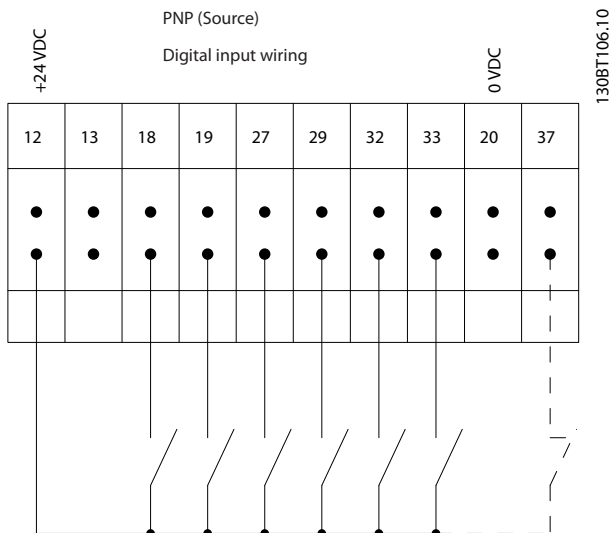

Illustration 1.3 PNP (Source)

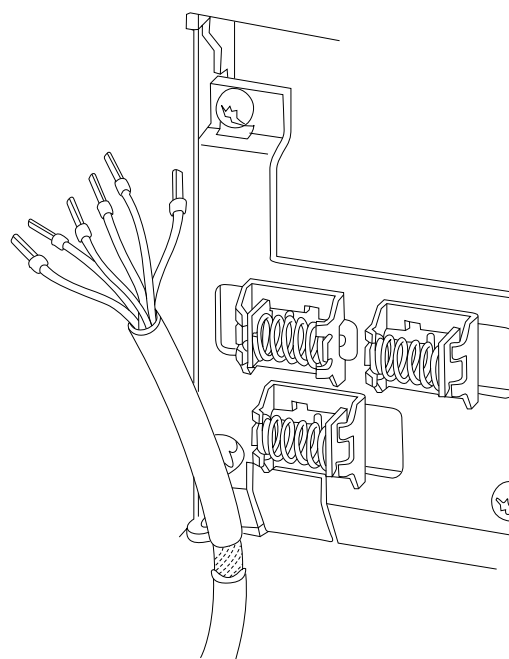

Illustration 1.5 Grounding of Shielded/Armored Control Cables

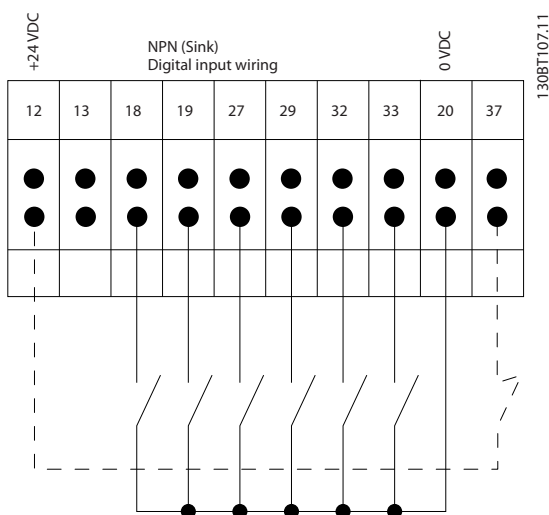
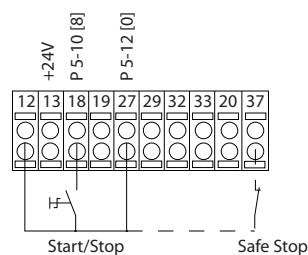

Illustration 1.4 NPN (Sink)

1.3.1 Start/Stop

Terminal 18 = parameter 5-10 Terminal 18 Digital Input [8] Start.
Terminal 27 = parameter 5-12 Terminal 27 Digital Input [0] No operation (Default [2] Coast inverse).
Terminal 37 = Safe Torque Off (where available).



NOTICE

Use shielded/armored control cables.

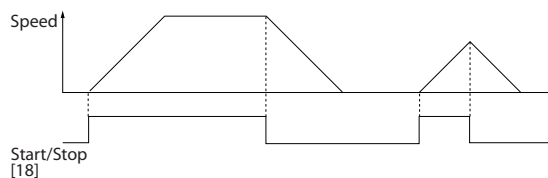

Illustration 1.6 Start/Stop

1.3.2 Pulse Start/Stop

Terminal 18 = parameter 5-10 Terminal 18 Digital Input, [9] Latched start.

Terminal 27 = parameter 5-12 Terminal 27 Digital Input, [6] Stop inverse.

Terminal 37 = Safe Torque Off (where available).

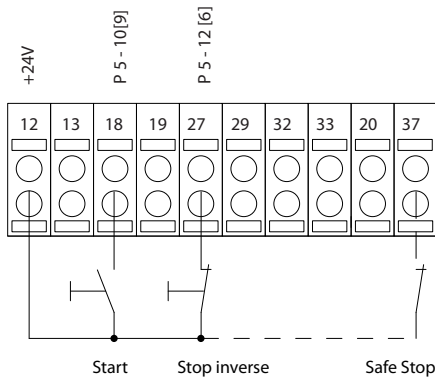

130BA156.12

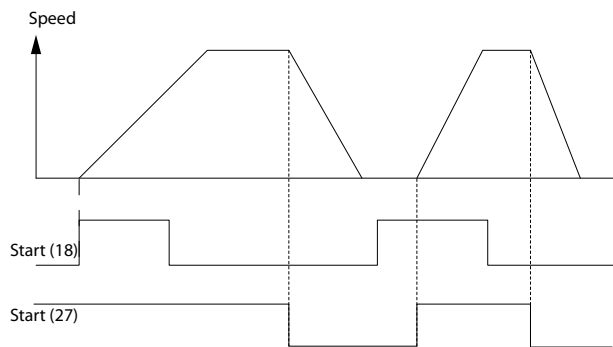

Illustration 1.7 Pulse Start/Stop

1.3.3 Speed up/Speed Down

Terminals 29/32 = Speed up/Speed down

Terminal 18 = Parameter 5-10 Terminal 18 Digital Input [9] Start (default).

Terminal 27 = Parameter 5-12 Terminal 27 Digital Input [19] Freeze reference.

Terminal 29 = Parameter 5-13 Terminal 29 Digital Input [21] Speed up.

Terminal 32 = Parameter 5-14 Terminal 32 Digital Input [22] Speed down.

NOTICE

Terminal 29 only in FC x02 (x=series type).

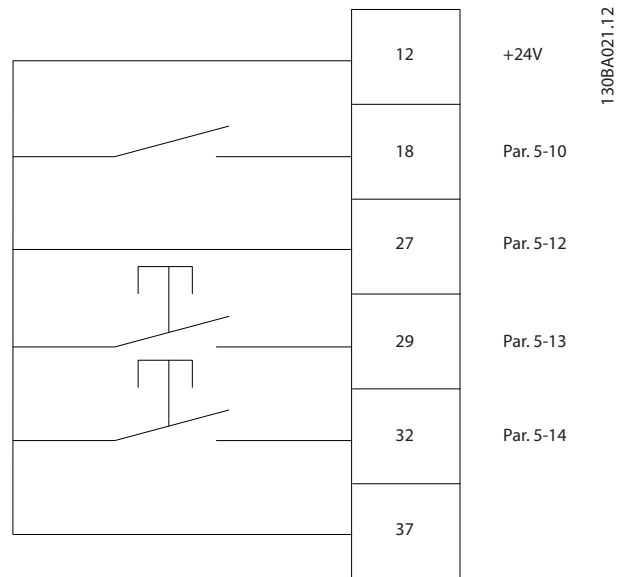

130BA021.12

Illustration 1.8 Speed up/Speed down

1.3.4 Potentiometer Reference

Voltage reference via a potentiometer

Reference source 1 = [1] Analog input 53 (default).

Terminal 53, low voltage = 0 V.

Terminal 53, high voltage = 10 V.

Terminal 53, low reference/feedback = 0 RPM.

Terminal 53, high reference/feedback = 1500 RPM.

Switch S201 = OFF (U)

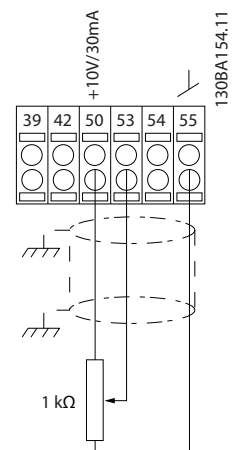
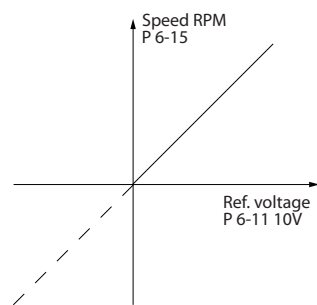

130BA154.11

Illustration 1.9 Potentiometer Reference

2 How to Program

2.1 Local Control Panel

2.1.1 How to Operate Graphical LCP (GLCP)

The GLCP is divided into 4 functional groups:

1. Graphical display with status lines.
2. Menu keys and indicator lights (LEDs) - selecting mode, changing parameters, and switching between display functions.
3. Navigation keys and indicator lights (LEDs).
4. Operation keys and indicator lights (LEDs).

Graphical display

The LCD display is backlit with a total of 6 alpha-numeric lines. All data is shown on the LCP, which can show up to 5 operating variables while in Status mode.

Display lines:

- a. **Status line**
Status messages displaying icons and graphics.
- b. **Line 1–2**
Operator data lines displaying data and variables defined or selected by the user. Press [Status] to add 1 extra line.
- c. **Status line**
Status messages displaying text.

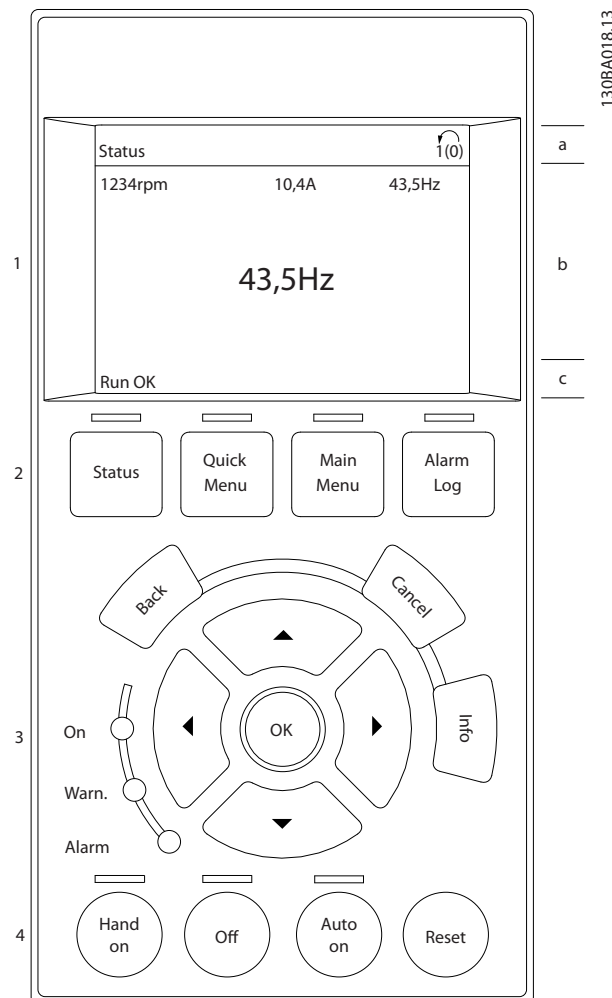

Illustration 2.1 LCP

The display is divided into 3 sections:

Top section

(a) shows the status when in Status mode, or up to 2 variables when not in Status mode, and in the case of alarm/warning.

The number of the active set-up (selected as the active set-up in *parameter 0-10 Active Set-up*) is shown. When programming in another set-up than the active set-up, the number of the set-up being programmed appears to the right in brackets.

Middle section

(b) shows up to 5 variables with related unit, regardless of status. In case of alarm/warning, the warning is shown instead of the variables.

Bottom section

(c) always shows the state of the frequency converter in status mode.

Press [Status] to toggle between 3 status readout displays.

Operating variables with different formatting are shown in each status screen.

Several values or measurements can be linked to each of the shown operating variables.

Define the values/measurements to be shown via:

- Parameter 0-20 Display Line 1.1 Small
- Parameter 0-21 Display Line 1.2 Small
- Parameter 0-22 Display Line 1.3 Small
- Parameter 0-23 Display Line 2 Large
- Parameter 0-24 Display Line 3 Large

which can be accessed via [Quick Menu], Q3 Function Set-ups, Q3-1 General Settings, Q3-13 Display Settings.

Each value/measurement readout parameter selected in parameter 0-20 Display Line 1.1 Small to parameter 0-24 Display Line 3 Large has its own scale and number of digits after a possible decimal point. Larger numeric values are shown with few digits after the decimal point.

Ex.: Current readout
5.25 A; 15.2 A 105 A.

Status display I

This readout state is standard after start-up or initialization. Press [INFO] to obtain information about the value/measurement linked to the shown operating variables (1.1, 1.2, 1.3, 2, and 3).

See the operating variables shown in the display in Illustration 2.2. 1.1, 1.2, and 1.3 are shown in small size. 2 and 3 are shown in medium size.

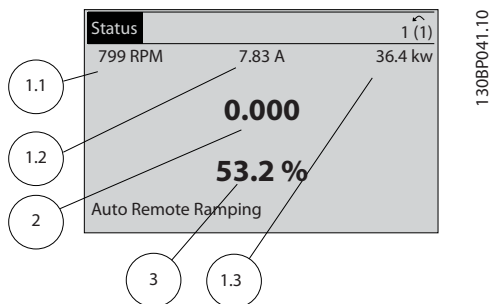

Illustration 2.2 Example of Status Display I

Status display II

See the operating variables (1.1, 1.2, 1.3, and 2) shown in the display in Illustration 2.3.

In the example, speed, motor current, motor power, and frequency are selected as variables in the first and second lines.

1.1, 1.2, and 1.3 are shown in small size. 2 is shown in large size.

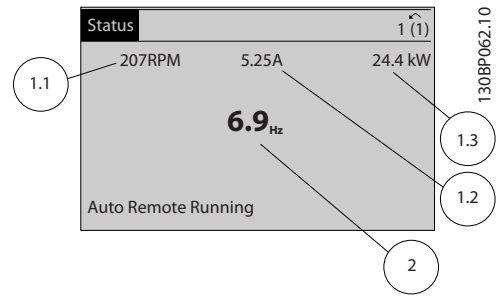

Illustration 2.3 Example of Status Display II

Status display III

This state displays the event and action of the smart logic control.

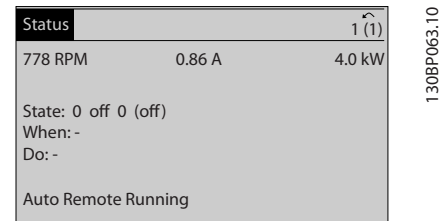

Illustration 2.4 Example of Status Display III

Display contrast adjustment

Press [Status] and [▲] for darker display.

Press [Status] and [▼] for brighter display.

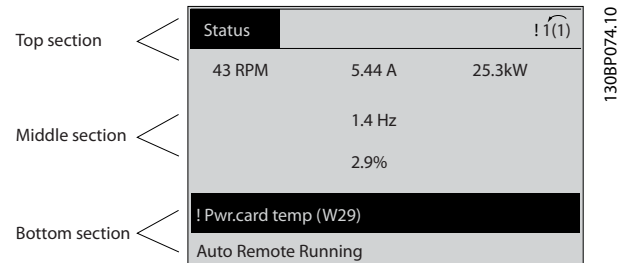

Illustration 2.5 Display Sections

Indicator lights (LEDs)

If certain threshold values are exceeded, the alarm and/or warning LED lights up. A status and alarm text appear in the display.

The On LED is activated when the frequency converter receives power from mains voltage, a DC bus terminal, or a 24 V external supply. At the same time, the backlight is on.

- Green LED/On: Control section is working.
- Yellow LED/Warn.: Indicates a warning.
- Flashing Red LED/Alarm: Indicates an alarm.

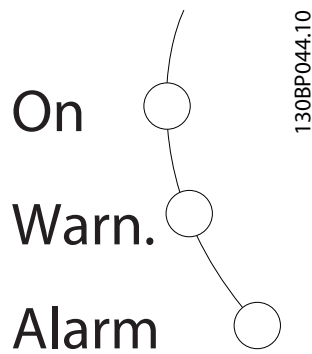

Illustration 2.6 Indicator Lights

GLCP keys**Menu keys**

The menu keys are divided into functions. The keys below the display and indicator lights are used for parameter set-up, including selection of display indication during normal operation.



Illustration 2.7 Menu Keys

[Status]

[Status] indicates the status of the frequency converter and/or the motor.

3 different readouts can be selected by pressing the [Status] key:

- 5-line readouts.
- 4-line readouts.
- Smart logic control.

Press [Status] to select the display mode or for changing back to *Display* mode from either *Quick Menu* mode, *Main Menu* mode, or *Alarm* mode. Also press [Status] to toggle between single or double readout mode.

[Quick Menu]

[Quick Menu] allows quick set-up of the frequency converter. The most common functions can be programmed here.

The Quick Menu consists of:

- My personal menu.
- Quick set-up.
- Function set-up.
- Changes made.
- Loggings.

The *Function Set-up* provides quick and easy access to all parameters required for most applications including:

- Most VAV and CAV supply and return fans.
- Cooling tower fans.
- Primary, secondary, and condenser water pumps.
- Other pump, fan, and compressor applications.

Among other features, it also includes parameters for selecting which variables to display in the LCP:

- Digital preset speeds.
- Scaling of analog references.
- Closed-loop single-zone and multi-zone applications.
- Specific functions related to fans, pumps, and compressors.

The Quick Menu parameters can be accessed immediately unless a password has been created via:

- *Parameter 0-60 Main Menu Password.*
- *Parameter 0-61 Access to Main Menu w/o Password.*
- *Parameter 0-65 Personal Menu Password.*
- *Parameter 0-66 Access to Personal Menu w/o Password.*

It is possible to switch directly between *Quick Menu* mode and *Main Menu* mode.

[Main Menu]

Press [Main Menu] to program all parameters. The main menu parameters can be accessed immediately unless a password has been created via:

- *Parameter 0-60 Main Menu Password.*
- *Parameter 0-61 Access to Main Menu w/o Password.*
- *Parameter 0-65 Personal Menu Password.*
- *Parameter 0-66 Access to Personal Menu w/o Password.*

For most applications, it is not necessary to access the main menu parameters. Instead, the *Quick Menu*, *Quick Set-up* and *Function Set-up* provide the simplest and quickest access to the most required parameters.

It is possible to switch directly between *Main Menu* mode and *Quick Menu* mode.

Parameter shortcut can be carried out by pressing [Main Menu] for 3 s. The parameter shortcut allows direct access to any parameter.

[Alarm Log]

[Alarm Log] displays an alarm list of the 10 most recent alarms (numbered A1-A10). To obtain more details about an alarm, press the navigation keys to manoeuvre to the alarm number and press [OK]. Information is shown about the condition of the frequency converter before it enters the alarm mode.

The [Alarm Log] key on the LCP allows access to both alarm log and maintenance log.

[Back]

[Back] reverts to the previous step or layer in the navigation structure.



Illustration 2.8 Back Key

[Cancel]

[Cancel] cancels the last change or command as long as the display has not been changed.



Illustration 2.9 Cancel Key

[Info]

[Info] displays information about a command, parameter, or function in any display window. [Info] provides detailed information when needed. Exit Info mode by pressing either [Info], [Back], or [Cancel].



Illustration 2.10 Info Key

Navigation Keys

The 4 navigation keys are used to navigate between the different options available in the Quick Menu, Main Menu, and Alarm Log. Press the keys to move the cursor.

[OK]

Press [OK] to select a parameter marked by the cursor and for enabling the change of a parameter.

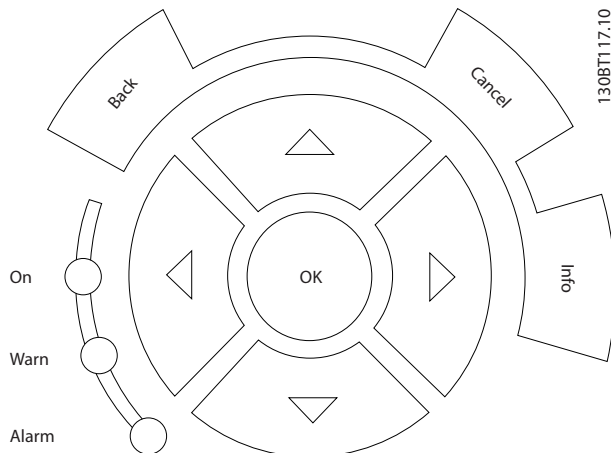

Illustration 2.11 Navigation Keys

Operation keys

Operation keys for local control are found at the bottom of the control panel.

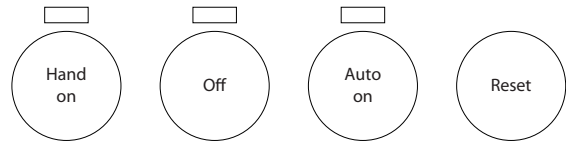

Illustration 2.12 Operation Keys

[Hand On]

[Hand On] enables control of the frequency converter via the GLCP. [Hand On] also starts the motor and allows entering the motor speed data with the navigation keys. The key can be selected as [1] Enable or [0] Disable via parameter 0-40 [Hand on] Key on LCP.

The following control signals are still active when [Hand On] is activated:

- [Hand On] - [Off] - [Auto On].
- Reset.
- Coasting stop inverse.
- Reversing.
- Set-up select lsb - Set-up select msb.
- Stop command from serial communication.
- Quick stop.
- DC brake.

NOTICE

External stop signals activated with control signals or a fieldbus override a start command via the LCP.

[Off]

[Off] stops the connected motor. The key can be selected as [1] Enabled or [0] Disabled via parameter 0-41 [Off] Key on LCP. If no external stop function is selected, and the [Off] key is inactive, the motor can only be stopped by disconnecting the mains supply.

[Auto On]

[Auto On] enables the frequency converter to be controlled via the control terminals and/or serial communication. When a start signal is applied on the control terminals and/or the bus, the frequency converter starts. The key can be selected as [1] Enabled or [0] Disabled via parameter 0-42 [Auto on] Key on LCP.

NOTICE

An active HAND-OFF-AUTO signal via the digital inputs has higher priority than the control keys [Hand On] – [Auto On].

[Reset]

Press [Reset] to reset the frequency converter after an alarm (trip). It can be selected as [1] Enable or [0] Disable via parameter 0-43 [Reset] Key on LCP.

The parameter shortcut can be carried out by pressing the [Main Menu] key for 3 s. The parameter shortcut allows direct access to any parameter.

2.1.2 Quick Transfer of Parameter Settings between Multiple Frequency Converters

Once the set-up of a frequency converter is complete, store the data in the LCP or on a PC via MCT 10 Set-up Software.

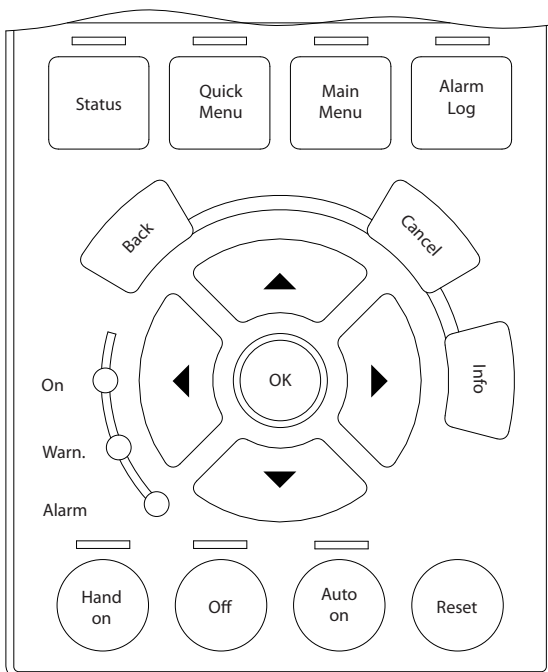

Illustration 2.13 LCP

Data storage in LCP

NOTICE

Stop the motor before performing this operation.

To store the data in the LCP:

1. Go to parameter 0-50 LCP Copy.
2. Press the [OK] key.
3. Select [1] All to LCP.
4. Press the [OK] key.

All parameter settings are now stored in the LCP indicated by the progress bar. When 100% is reached, press [OK].

Connect the LCP to another frequency converter and copy the parameter settings to this frequency converter as well.

Data transfer from LCP to frequency converter

NOTICE

Stop the motor before performing this operation.

To transfer the data from the LCP to the frequency converter:

1. Go to parameter 0-50 LCP Copy.
2. Press the [OK] key.
3. Select [2] All from LCP.
4. Press the [OK] key.

The parameter settings stored in the LCP are now transferred to the frequency converter indicated by the progress bar. When 100% is reached, press [OK].

2.1.3 Parameter Set-Up

The frequency converter can be used for practically all assignments, thus offering a significant number of parameters. The series offers a choice between 2 programming modes - the *Quick Menu* mode and the *Main Menu* mode.

The *Main Menu* provides access to all parameters. The *Quick Menu* takes the user through a few parameters making it possible to program the majority of applications. Regardless of the programming mode, parameters can be changed in both *Quick Menu* mode and in *Main Menu* mode.

2.1.4 Quick Menu Mode

Parameter data

The graphical display (GLCP) provides access to all parameters listed in the *Quick Menu*. The numeric display (NLCP) only provides access to the *Quick Set-up* parameters.

To set parameters pressing [Quick Menu] - enter or change parameter data or settings in accordance with the following procedure:

1. Press [Quick Menu].
2. Press [▲] or [▼] to find the parameter to change.
3. Press [OK].
4. Press [▲] or [▼] to select the correct parameter setting.
5. Press [OK].
6. To move to a different digit within a parameter setting, use the [◀] and [▶].

7. Highlighted area indicates digit selected for change.
8. Press [Cancel] to disregard change, or press [OK] to accept change and enter the new setting.

Example of changing parameter data

Assume that *parameter 22-60 Broken Belt Function* is set to [0] Off. To monitor the fan-belt condition, non-broken or broken, follow this procedure:

1. Press [Quick Menu].
2. Press [▼] to select *Function Set-ups*.
3. Press [OK].
4. Press [▼] to select *Application Settings*.
5. Press [OK].
6. Press [OK] again for *Fan Functions*.
7. Press [OK] to select *Broken Belt Function*.
8. Press [▼], to select [2] Trip.

If a broken fan belt is detected, the frequency converter trips.

Select Q1 My Personal Menu to display personal parameters

For example, an AHU or pump OEM may have pre-programmed personal parameters to be in *My Personal Menu* during factory commissioning to make on-site commissioning/fine-tuning simpler. These parameters are selected in *parameter 0-25 My Personal Menu*. Up to 20 different parameters can be programmed in this menu.

Select Changes Made for information about:

- The last 10 changes. Press [▲] and [▼] to scroll between the last 10 changed parameters.
- The changes made since default setting.

Loggings

Loggings show information about the display line readouts. The information is shown as graphs. Only display parameters selected in *parameter 0-20 Display Line 1.1 Small* and *parameter 0-24 Display Line 3 Large* can be viewed. Up to 120 samples can be stored in the memory for later reference.

Quick set-up

Efficient parameter set-up for refrigeration applications

The parameters can easily be set up for most refrigeration applications only by using the *Quick Set-up*. After pressing [Quick Menu], the different options in the *Quick Menu* are listed. See also *Illustration 2.14*.

Example of using the quick set-up

To set the ramp-down time to 100 s, follow this procedure:

1. Select *Quick Set-up. Parameter 0-01 Language* in Quick Set-up appears.
2. Press [▼] repeatedly until *parameter 3-42 Ramp 1 Ramp Down Time* appears with the default setting of 20 s.
3. Press [OK].
4. Press [◀] to highlight the third digit before the comma.
5. Change 0 to 1 by pressing [▲].
6. Press [▶] to highlight the digit 2.
7. Change 2 to 0 by pressing [▼].
8. Press [OK].

The new ramp-down time is now set to 100 s.

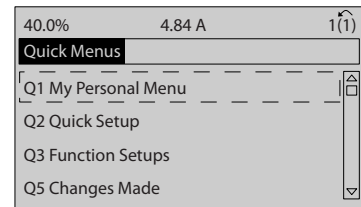

Illustration 2.14 Quick Menu View

Access the 18 most important set-up parameters of the frequency converter via *Quick Set-up*. After programming, the frequency converter is ready for operation. The 18 *Quick Set-up* parameters are shown in *Table 2.1*.

Parameter	[Units]
<i>Parameter 0-01 Language</i>	-
<i>Parameter 1-03 Torque Characteristics</i>	-
<i>Parameter 1-20 Motor Power [kW]</i>	[kW]
<i>Parameter 1-21 Motor Power [HP]</i>	[hp]
<i>Parameter 1-22 Motor Voltage</i>	[V]
<i>Parameter 1-23 Motor Frequency</i>	[Hz]
<i>Parameter 1-24 Motor Current</i>	[A]
<i>Parameter 1-25 Motor Nominal Speed</i>	[RPM]
<i>Parameter 1-39 Motor Poles</i>	-
<i>Parameter 4-12 Motor Speed Low Limit [Hz]</i>	[Hz]
<i>Parameter 4-14 Motor Speed High Limit [Hz]</i>	[Hz]
<i>Parameter 3-02 Minimum Reference</i>	-
<i>Parameter 3-03 Maximum Reference</i>	-
<i>Parameter 3-41 Ramp 1 Ramp Up Time</i>	[s]
<i>Parameter 3-42 Ramp 1 Ramp Down Time</i>	[s]
<i>Parameter 3-13 Reference Site</i>	-
<i>Parameter 5-10 Terminal 18 Digital Input</i>	-
<i>Parameter 1-29 Automatic Motor Adaptation (AMA)</i>	-

Table 2.1 Quick Set-up Parameters

2.1.5 Function Set-ups

The *function set-up* provides quick and easy access to all parameters required for most refrigeration applications including:

- Most VAV and CAV supply and return fans.
- Cooling tower fans.
- Primary pumps.
- Secondary pumps.
- Condenser water pumps.
- Other pump, fan, and compressor applications.

How to access *Function Set-up* - example

1. Turn on the frequency converter (yellow LED lights).

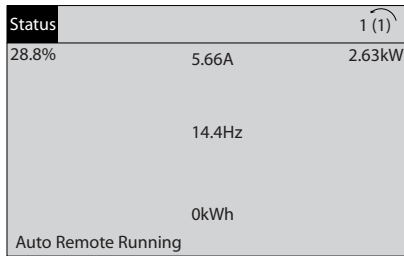

Illustration 2.15 Frequency Converter Turned On

2. Press [Quick Menus].

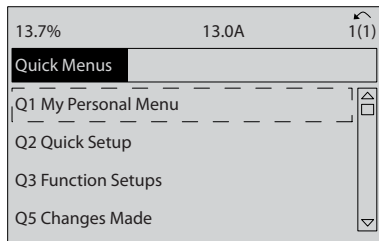

Illustration 2.16 Quick Menu Selected

3. Press [▲] and [▼] to scroll down to *Function Set-ups*. Press [OK].

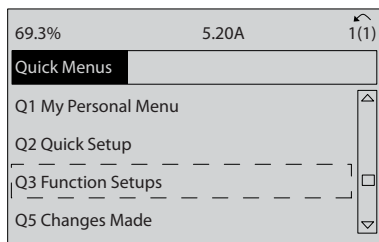

Illustration 2.17 Scrolling to Function Set-up

4. *Function Set-ups* options appear. Select *Q3-1 General Settings*. Press [OK].

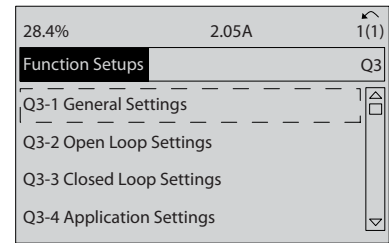

Illustration 2.18 Function Set-ups Options

5. Press [▲] and [▼] to scroll down to *Q3-11 Analog Outputs*. Press [OK].

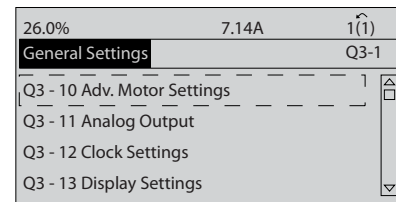

Illustration 2.19 General Settings Options

6. Select *parameter 6-50 Terminal 42 Output*. Press [OK].

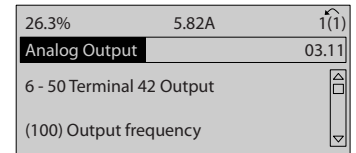

Illustration 2.20 Parameter 6-50 Terminal 42 Output Selected

7. Press [▲] and [▼] to select between the different options. Press [OK].

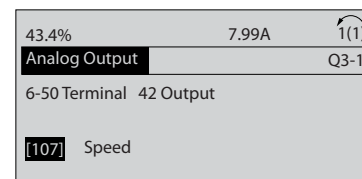

Illustration 2.21 Setting a Parameter

Function set-up parameters

The function set-up parameters are grouped in the following way:

Q3-10 Adv. Motor Settings	Q3-11 Analog Output	Q3-12 Clock Settings	Q3-13 Display Settings
Parameter 1-90 Motor Thermal Protection	Parameter 6-50 Terminal 42 Output	Parameter 0-70 Set Date and Time	Parameter 0-20 Display Line 1.1 Small
Parameter 1-93 Thermistor Source	Parameter 6-51 Terminal 42 Output Min Scale	Parameter 0-71 Date Format	Parameter 0-21 Display Line 1.2 Small
Parameter 1-29 Automatic Motor Adaptation (AMA)	Parameter 6-52 Terminal 42 Output Max Scale	Parameter 0-72 Time Format	Parameter 0-22 Display Line 1.3 Small
Parameter 14-01 Switching Frequency	–	Parameter 0-74 DST/Summertime	Parameter 0-23 Display Line 2 Large
–	–	Parameter 0-76 DST/Summertime Start	Parameter 0-24 Display Line 3 Large
–	–	Parameter 0-77 DST/Summertime End	Parameter 0-37 Display Text 1
–	–	–	Parameter 0-38 Display Text 2
–	–	–	Parameter 0-39 Display Text 3

Table 2.2 Q3-1 General Settings

Q3-2 Open Loop Settings
Parameter 1-00 Configuration Mode
Parameter 3-02 Minimum Reference
Parameter 3-03 Maximum Reference
Parameter 3-15 Reference 1 Source
Parameter 6-10 Terminal 53 Low Voltage
Parameter 6-11 Terminal 53 High Voltage
Parameter 6-14 Terminal 53 Low Ref./Feedb. Value
Parameter 6-15 Terminal 53 High Ref./Feedb. Value
Parameter 3-10 Preset Reference

Table 2.3 Q3-2 Open Loop Settings

Q3-3 Closed Loop Settings
Parameter 1-00 Configuration Mode
Parameter 20-00 Feedback 1 Source
Parameter 20-12 Reference/Feedback Unit
Parameter 6-20 Terminal 54 Low Voltage
Parameter 6-21 Terminal 54 High Voltage
Parameter 6-22 Terminal 54 Low Current
Parameter 6-23 Terminal 54 High Current
Parameter 6-24 Terminal 54 Low Ref./Feedb. Value
Parameter 6-25 Terminal 54 High Ref./Feedb. Value
Parameter 3-02 Minimum Reference
Parameter 3-03 Maximum Reference
Parameter 20-21 Setpoint 1
Parameter 20-93 PID Proportional Gain
Parameter 20-94 PID Integral Time
Parameter 3-13 Reference Site

Table 2.4 Q3-3 Closed Loop Settings

Compressor	Condenser	Single fan/pump
Parameter 22-75 Short Cycle Protection	Parameter 22-40 Minimum Run Time	Parameter 22-40 Minimum Run Time
Parameter 22-76 Interval between Starts	Parameter 22-41 Minimum Sleep Time	Parameter 22-41 Minimum Sleep Time
Parameter 22-77 Minimum Run Time	Parameter 22-42 Wake-up Speed [RPM]	Parameter 22-42 Wake-up Speed [RPM]
Parameter 20-00 Feedback 1 Source	Parameter 22-43 Wake-up Speed [Hz]	Parameter 22-43 Wake-up Speed [Hz]
Parameter 20-01 Feedback 1 Conversion	Parameter 22-44 Wake-up Ref./FB Difference	Parameter 22-44 Wake-up Ref./FB Difference
Parameter 20-02 Feedback 1 Source Unit	Parameter 20-00 Feedback 1 Source	-
Parameter 20-30 Refrigerant	Parameter 20-01 Feedback 1 Conversion	-
Parameter 20-40 Thermostat/Pressostat Function	Parameter 20-02 Feedback 1 Source Unit	-
Parameter 20-41 Cut-out Value	Parameter 20-30 Refrigerant	-
Parameter 20-42 Cut-in Value	Parameter 20-40 Thermostat/Pressostat Function	-
Parameter 25-00 Pack Controller	Parameter 20-41 Cut-out Value	-
Parameter 25-06 Number of Compressors	Parameter 20-42 Cut-in Value	-
Parameter 25-20 Neutral Zone [unit]	-	-
Parameter 25-21 + Zone [unit]	-	-
Parameter 25-22 - Zone [unit]	-	-

Table 2.5 Q3-4 Application Settings

2.1.6 Main Menu Mode

To select the *Main Menu* mode, press the [Main Menu] key. Lines 2–5 on the display show parameter groups which can be selected by pressing [▲] and [▼].

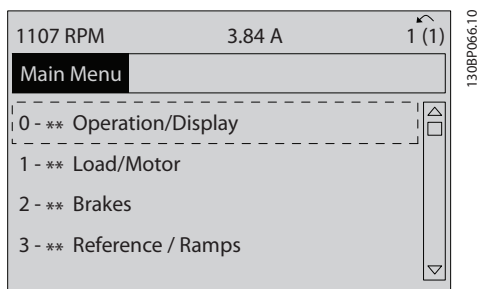

Illustration 2.22 Display Example

Each parameter has a name and a number which remain the same regardless of the programming mode. In the *Main Menu* mode, the parameters are divided into groups.

All parameters can be changed in the *Main Menu*. The configuration of the unit (*parameter 1-00 Configuration Mode*) determines other parameters available for programming. For example, selecting [3] *Process Closed Loop* enables additional parameters related to closed-loop operation. Options installed on the frequency converter enable extra parameters associated with the option.

2.1.7 Parameter Selection

In the *Main Menu* mode, the parameters are divided into groups. Press the navigation keys to select parameter group.

The following parameter groups are accessible:

Group number	Parameter group
0-**	Operation/Display
1-**	Load/Motor
2-**	Brakes
3-**	References/Ramps
4-**	Limits/Warnings
5-**	Digital In/Out
6-**	Analog In/Out
8-**	Comm. and Options
11-**	LonWorks
13-**	Smart Logic
14-**	Special Functions
15-**	Drive Information
16-**	Data Readouts
18-**	Info & Readouts
20-**	Drive Closed Loop
21-**	Ext. Closed Loop
22-**	Application Functions
23-**	Time-based Functions
25-**	Pack Controller
26-**	Analog I/O Option
28-**	Compressor Functions

Table 2.6 Parameter Groups

After selecting a parameter group, press the navigation keys to select a parameter.

The middle section on the display shows the parameter number and name, as well as the selected parameter value.

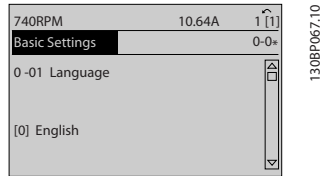

Illustration 2.23 Parameter Selection

2.1.8 Changing Data

Press [OK] to change the selected parameter. The procedure for changing data depends on whether the selected parameter represents a numerical data value or a text value.

2.1.9 Changing a Text Value

If the selected parameter is a text value, change the text value with the [▲] [▼] keys. Place the cursor on the value that should be saved and press [OK].

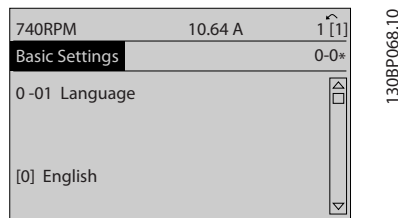

Illustration 2.24 Changing a Text Value

2.1.10 Changing a Group of Numeric Data Values

If the selected parameter represents a numeric data value, change the data value pressing the [◀] [▶] navigation keys, as well as the [▲] [▼] navigation keys. Press [◀] [▶] keys to move the cursor horizontally.

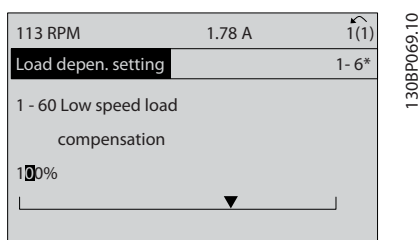

Illustration 2.25 Changing a Group of Numeric Data Values

Press the [▲] [▼] keys to change the data value. [▲] increases the data value, and [▼] decreases the data value. Place the cursor on the value to save and press [OK].

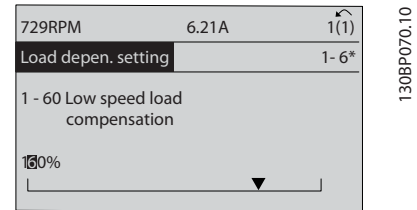

Illustration 2.26 Changing a Group of Numeric Data Values

2.1.11 Value, Step-by-step

Certain parameters can be changed step by step. This applies to:

- Parameter 1-20 Motor Power [kW].
- Parameter 1-22 Motor Voltage.
- Parameter 1-23 Motor Frequency.

The parameters are changed both as a group of numeric data values and as numeric data values that are infinitely varying.

2.1.12 Read out and Programming of Indexed Parameters

Parameters are indexed when placed in a rolling stack. *Parameter 15-30 Alarm Log: Error Code* to *parameter 15-33 Alarm Log: Date and Time* contain a fault log which can be read out. Select a parameter, press [OK], and use the [▲]/[▼] navigation keys to scroll through the value log.

Use *parameter 3-10 Preset Reference* as another example: Select the parameter, press [OK], and use the [▲]/[▼] navigation keys to scroll through the indexed values. To change the parameter value, select the indexed value and press [OK]. To change the value, press the [▲]/[▼] keys. Press [OK] to accept the new setting. Press [Cancel] to abort. Press [Back] to leave the parameter.

2.1.13 Initialization to Default Settings

Initialize the frequency converter to default settings in 2 ways.

Recommended initialization (via parameter 14-22 Operation Mode)

1. Select *parameter 14-22 Operation Mode*.
2. Press [OK].
3. Select [2] Initialization.

4. Press [OK].
5. Cut off the mains supply and wait until the display turns off.
6. Reconnect the mains supply - the frequency converter is now reset.
7. Change *parameter 14-22 Operation Mode* back to [0] Normal Operation.

NOTICE

Resets parameters selected in Personal Menu with default factory setting.

Parameter 14-22 Operation Mode initializes all except:

Parameter 14-50 RFI Filter.

Parameter 8-30 Protocol.

Parameter 8-31 Address.

Parameter 8-32 Baud Rate.

Parameter 8-35 Minimum Response Delay.

Parameter 8-36 Maximum Response Delay.

Parameter 8-37 Maximum Inter-Char Delay.

Parameter 15-00 Operating hours to *parameter 15-05 Over Volt's.*

Parameter 15-20 Historic Log: Event to *parameter 15-22 Historic Log: Time.*

Parameter 15-30 Alarm Log: Error Code to *parameter 15-32 Alarm Log: Time.*

Manual initialization

1. Disconnect from mains and wait until the display turns off.
2.
 - 2a Press [Status] - [Main Menu] - [OK] at the same time while powering up (LCP 102, graphical display).
 - 2b Press [Menu] while powering up (LCP 101, numerical display).
3. Release the keys after 5 s.
4. The frequency converter is now programmed according to default settings.

This procedure initializes all except:

- *Parameter 15-00 Operating hours.*
- *Parameter 15-03 Power Up's.*
- *Parameter 15-04 Over Temp's.*
- *Parameter 15-05 Over Volt's.*

NOTICE

Manual initialization:

- Resets serial communication.
- Resets *parameter 14-50 RFI Filter* and fault log settings.
- Removes parameters selected in *parameter 25-00 Pack Controller.*

NOTICE

After initialization and power cycling, the display does not show any information until after a couple of minutes.

3 Parameter Description

3.1 Parameter Selection

3.1.1 Main Menu Structure

Parameters for the frequency converter are grouped into various parameter groups for easy selection of the correct parameters for optimized operation of the frequency converter.

Most refrigeration applications can be programmed by pressing [Quick Menu] and selecting the parameters under *Quick Setup* and *Function Set-ups*.

Descriptions and default settings of parameters are in *chapter 4 Parameter Lists*.

Parameter groups

- 0-** Operation/Display
- 1-** Load and Motor
- 2-** Brakes
- 3-** Reference/Ramps
- 4-** Limits/Warnings
- 5-** Digital In/Out
- 6-** Analog In/Out
- 8-** Comm. and Options
- 11-** LonWorks
- 13-** Smart Logic
- 14-** Special Functions
- 15-** Drive Information
- 16-** Data Readouts
- 18-** Info & Readouts
- 20-** Drive Closed Loop
- 21-** Ext. Closed Loop
- 22-** Appl. Functions
- 23-** Time-based Functions
- 25-** Pack Controller
- 26-** Analog I/O Option
- 28-** Compressor Functions

3.2 Parameters: 0-** Operation and Display

Parameters related to the fundamental functions of the frequency converter, function of the LCP keys, and configuration of the LCP display.

0-01 Language		
Option:	Function:	
		Defines the language to be used in the display. The frequency converter is delivered with 2 different language packages. English and German are included in both packages. English cannot be erased or manipulated.
[0] *	English	Part of language packages 1–2.
[1]	Deutsch	Part of language packages 1–2.
[2]	Francais	Part of language package 1.
[3]	Dansk	Part of language package 1.
[4]	Spanish	Part of language package 1.
[5]	Italiano	Part of language package 1.
[6]	Svenska	Part of language package 1.
[7]	Nederlands	Part of language package 1.
[10]	Chinese	Part of language package 2.
[20]	Suomi	Part of language package 1.
[22]	English US	Part of language package 1.
[27]	Greek	Part of language package 1.
[28]	Bras.port	Part of language package 1.
[36]	Slovenian	Part of language package 1.
[39]	Korean	Part of language package 2.
[40]	Japanese	Part of language package 2.
[41]	Turkish	Part of language package 1.
[42]	Trad.Chinese	Part of language package 2.
[43]	Bulgarian	Part of language package 1.
[44]	Srpski	Part of language package 1.
[45]	Romanian	Part of language package 1.
[46]	Magyar	Part of language package 1.
[47]	Czech	Part of language package 1.
[48]	Polski	Part of language package 1.
[49]	Russian	Part of language package 1.
[50]	Thai	Part of language package 2.
[51]	Bahasa Indonesia	Part of language package 2.
[52]	Hrvatski	Part of language package 2.

0-02 Motor Speed Unit		
Option:	Function:	
		<p>NOTICE This parameter cannot be adjusted while the motor is running.</p> <p>The information shown in the display depends on settings in <i>parameter 0-02 Motor Speed Unit</i> and <i>parameter 0-03 Regional Settings</i>. The default settings of <i>parameter 0-02 Motor Speed Unit</i> and <i>parameter 0-03 Regional Settings</i> depend on to which region of the world the frequency converter is supplied.</p> <p>NOTICE Changing the motor speed unit resets certain parameters to their initial value. Select the motor speed unit before modifying other parameters.</p>
[0]	RPM	Select to show motor speed variables and parameters using motor speed (RPM).
[1] *	Hz	Select to show motor speed variables and parameters using output frequency (Hz).

0-03 Regional Settings		
Option:	Function:	
		<p>NOTICE This parameter cannot be adjusted while the motor is running.</p> <p>The display output depends on the settings in <i>parameter 0-02 Motor Speed Unit</i> and <i>parameter 0-03 Regional Settings</i>. The default settings of <i>parameter 0-02 Motor Speed Unit</i> and <i>parameter 0-03 Regional Settings</i> depend on which region of the world the frequency converter is supplied to. Reprogram the settings as required.</p> <p>The settings not used are made invisible.</p>
[0]	International	Sets <i>parameter 1-20 Motor Power [kW]</i> units to [kW] and the default value of <i>parameter 1-23 Motor Frequency</i> [50 Hz].
[1]	North America	Sets <i>parameter 1-21 Motor Power [HP]</i> units to [hp] and the default value of <i>parameter 1-23 Motor Frequency</i> to 60 Hz.

0-04 Operating State at Power-up		
Option:	Function:	
		Select the operating mode after reconnection of the frequency converter to mains voltage after power-down when operating in hand-on (local) mode.

0-04 Operating State at Power-up		
Option:	Function:	
[0] *	Resume	Resumes operation of the frequency converter maintaining the same local reference and the same start/stop condition (applied by [Hand On]/[Off] on the LCP or local start via a digital input as before the frequency converter was powered down.
[1]	Forced stop, ref=old	Stops the frequency converter, but at the same time retains the local speed reference before power-down in the memory. After mains voltage is reconnected and after receiving a start command (pressing [Hand On] or local start command via a digital input), the frequency converter restarts and operates at the retained speed reference.

0-05 Local Mode Unit		
Option:	Function:	
		Defines if the local reference unit is shown in terms of the motor shaft speed (in RPM/Hz) or as percent.
[0] *	As Motor Speed Unit	
[1]	%	

3.2.1 0-1* Set-up Operations

Define and control the individual parameter set-ups. The frequency converter has 4 parameter set-ups that can be programmed independently of each other. This makes the frequency converter very flexible and able to meet the requirements of many different refrigeration system control schemes, often saving the cost of external control equipment. For example, these can be used to program the frequency converter to operate according to 1 control scheme in 1 set-up (for example daytime operation) and another control scheme in another set-up (for example night setback). Alternatively, they can be used by an AHU or packaged unit OEM to identically program all their factory fitted frequency converters for different equipment models within a range to have the same parameters, and then during production/commissioning simply select a specific set-up depending on which model within that range the frequency converter is installed on. The active set-up (that is the set-up in which the frequency converter is currently operating) can be selected in *parameter 0-10 Active Set-up* and is shown in the LCP. Use [9] *Multi set-up* to switch between set-ups with the frequency converter running or stopped, via digital input or serial communication commands (for example for night setback). If it is necessary to change setups while running, ensure that *parameter 0-12 This Set-up Linked to* is programmed as required. For most refrigeration applications it is not necessary to program *parameter 0-12 This Set-up Linked to* even if change of set-

up while running is required. However, for complex applications, using the full flexibility of the multiple set-ups, programming *parameter 0-12 This Set-up Linked to* may be required. Using *parameter 0-11 Programming Set-up*, it is possible to edit parameters within any of the set-ups while continuing the frequency converter operation in its active set-up which can be a different set-up to the one being edited. Using *parameter 0-51 Set-up Copy*, it is possible to copy parameter settings between the set-ups to enable quicker commissioning if similar parameter settings are required in different set-ups.

0-10 Active Set-up		
Option:	Function:	
		Select the set-up in which the frequency converter is to operate. Use <i>parameter 0-51 Set-up Copy</i> to copy a set-up to 1 or all other set-ups. To avoid conflicting settings of the same parameter within 2 different set-ups, link the set-ups using <i>parameter 0-12 This Set-up Linked to</i> . Stop the frequency converter before switching between set-ups where parameters marked <i>not changeable during operation</i> have different values. Parameters which are <i>not changeable during operation</i> are marked FALSE in <i>chapter 4 Parameter Lists</i> .
[0]	Factory setup	Cannot be changed. It contains the Danfoss data set, and can be used as a data source when returning the other set-ups to a known state.
[1]	Set-up 1 *	[1] Set-up 1 to [4] Set-up 4 are the 4 parameter set-ups within which all parameters can be programmed.
[2]	Set-up 2	
[3]	Set-up 3	
[4]	Set-up 4	
[9]	Multi Set-up	Is used for remote set-up selections using digital inputs and the serial communication port. This set-up uses the settings from <i>parameter 0-12 This Set-up Linked to</i> .

0-11 Programming Set-up		
Option:	Function:	
		Select the set-up to be edited (that is programmed) during operation; either the active set-up or 1 of the inactive set-ups. The set-up number being edited is shown in the LCP in brackets.
[0]	Factory setup	Cannot be edited, but it is useful as a data source to return the other set-ups to a known state.

0-11 Programming Set-up		
Option:	Function:	
[1]	Set-up 1	[1] Set-up 1 to [4] Set-up 4 can be edited freely during operation, independently of the active set-up.
[2]	Set-up 2	
[3]	Set-up 3	
[4]	Set-up 4	
[9] *	Active Set-up	The set-up in which the frequency converter is operating can be edited during operation. Editing parameters in the selected set-up would normally be done from the LCP, but it is also possible from any of the serial communication ports.

0-12 This Set-up Linked to		
Option:	Function:	
		Use this parameter only if a change of set-ups is required while the motor is running. This parameter ensures that parameters which are not changeable during operation have the same setting in all relevant set-ups. To enable conflict-free changes from 1 set-up to another while the frequency converter is running, link set-ups containing parameters which are not changeable during operation. The link ensures synchronizing of the <i>not changeable during operation</i> parameter values when moving from 1 set-up to another during operation. <i>Not changeable during operation</i> parameters can be identified by the label FALSE in the parameter lists in <i>chapter 4 Parameter Lists</i> . The <i>parameter 0-12 This Set-up Linked to</i> feature is used when [9] <i>Multi set-up</i> in <i>parameter 0-10 Active Set-up</i> is selected. Use [9] <i>Multi set-up</i> to move from 1 set-up to another during operation while the motor runs. For example: Use [9] <i>Multi set-up</i> to shift from set-up 1 to set-up 2 while the motor runs. Program parameters in set-up 1 first, then ensure that set-up 1 and set-up 2 are synchronized (or linked). Synchronization can be performed in 2 ways: <ul style="list-style-type: none"> Change the edit set-up to [2] Set-up 2 in <i>parameter 0-11 Programming Set-up</i> and set <i>parameter 0-12 This Set-up Linked to</i> to [1] Set-up 1. This starts the linking (synchronizing) process.

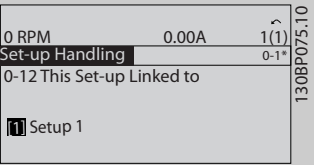
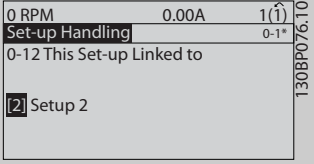
0-12 This Set-up Linked to	
Option:	Function:
	 <p>Illustration 3.1 Set-up Handling</p> <ul style="list-style-type: none"> While still in set-up 1, using <i>parameter 0-50 LCP Copy</i>, copy set-up 1 to set-up 2. Then set <i>parameter 0-12 This Set-up Linked to</i> to [2] Set-up 2. This starts the linking process.  <p>Illustration 3.2 Set-up Handling</p> <p>After the link is complete, <i>parameter 0-13 Readout: Linked Set-ups</i> reads set-ups 1 and 2 to indicate that all <i>not changeable during operation</i> parameters are now the same in set-up 1 and set-up 2. If there are changes to a <i>not changeable during operation</i> parameter in set-up 2, for example <i>parameter 1-30 Stator Resistance (Rs)</i>, they are also changed automatically in set-up 1. A switch between set-up 1 and set-up 2 during operation is now possible.</p>
[0] *	Not linked
[1]	Set-up 1
[2]	Set-up 2
[3]	Set-up 3
[4]	Set-up 4

0-13 Readout: Linked Set-ups	
Range:	Function:
0* [0 - 255]	View a list of all the set-ups linked by <i>parameter 0-12 This Set-up Linked to</i> . The parameter has 1 index for each parameter set-up. The value for each index shows which set-ups are linked to that parameter set-up.

0-13 Readout: Linked Set-ups													
Range:	Function:												
Array [5]													
	<table border="1"> <thead> <tr> <th>Index</th> <th>LCP value</th> </tr> </thead> <tbody> <tr> <td>0</td> <td>{0}</td> </tr> <tr> <td>1</td> <td>{1,2}</td> </tr> <tr> <td>2</td> <td>{1,2}</td> </tr> <tr> <td>3</td> <td>{3}</td> </tr> <tr> <td>4</td> <td>{4}</td> </tr> </tbody> </table> <p>Table 3.1 Set-up Link Example</p>	Index	LCP value	0	{0}	1	{1,2}	2	{1,2}	3	{3}	4	{4}
Index	LCP value												
0	{0}												
1	{1,2}												
2	{1,2}												
3	{3}												
4	{4}												

0-14 Readout: Prog. Set-ups / Channel	
Range:	Function:
0* [-2147483648 - 2147483647]	View the setting of <i>parameter 0-11 Programming Set-up</i> for each of the 4 different communication channels. When the number is shown in hex, as it is in the LCP, each number shows 1 channel. Numbers 1–4 show a set-up number; F stands for the factory setting, and A stands for an active set-up. The channels are, from right to left: LCP, fieldbus, USB, HPFB1.5. Example: The value AAAAAA21h means that the fieldbus channel uses set-up 2 in <i>parameter 0-11 Programming Set-up</i> , the LCP uses set-up 1, and all other channels use the active set-up.

3.2.2 0-2* LCP Display

Define the variables shown in the LCP.

NOTICE

For information on how to write display texts, refer to:

- *Parameter 0-37 Display Text 1.*
- *Parameter 0-38 Display Text 2.*
- *Parameter 0-39 Display Text 3.*

0-20 Display Line 1.1 Small	
Option:	Function:
	Select a variable for display in line 1, left position.
[37]	Display Text 1 Enables an individual text string to be written for display in the LCP, or to be read via serial communication.
[38]	Display Text 2 Enables an individual text string to be written for display in the LCP, or to be read via serial communication.

0-20 Display Line 1.1 Small		
Option:	Function:	
[39]	Display Text 3	Enables an individual text string to be written for display in the LCP, or to be read via serial communication.
[89]	Date and Time Readout	Displays the current date and time.
[953]	Profibus Warning Word	Displays PROFIBUS communication warnings.
[1397]	Alert Alarm Word	
[1398]	Alert Warning Word	
[1399]	Alert Status Word	
[1501]	Running Hours	View the number of running hours of the motor.
[1502]	kWh Counter	View the mains power consumption in kWh.
[1580]	Fan Running Hours	
[1600]	Control Word	View the control word sent from the frequency converter via the serial communication port in hex code.
[1601]	Reference [Unit]	Total reference (sum of digital/analog/preset/bus/freeze reference/catch up, and slow-down) in selected unit.
[1602]	Reference [%]	Total reference (sum of digital/analog/preset/bus/freeze reference/catch up, and slow-down) in percent.
[1603]	Status Word	Present status word
[1605]	Main Actual Value [%]	View the 2-byte word sent with the status word to the bus master reporting the main actual value.
[1609]	Custom Readout	View the user-defined readouts as defined in: <ul style="list-style-type: none"> Parameter 0-30 Custom Readout Unit. Parameter 0-31 Custom Readout Min Value. Parameter 0-32 Custom Readout Max Value.
[1610]	Power [kW]	Actual power consumed by the motor in kW.
[1611]	Power [hp]	Actual power consumed by the motor in hp.
[1612]	Motor Voltage	Voltage supplied to the motor.
[1613]	Frequency	Motor frequency, that is the output frequency from the frequency converter in Hz.

0-20 Display Line 1.1 Small		
Option:	Function:	
[1614]	Motor current	Phase current of the motor measured as effective value.
[1615]	Frequency [%]	Motor frequency, that is the output frequency from the frequency converter in percent.
[1616]	Torque [Nm]	Present motor load as a percentage of the rated motor torque.
[1617]	Speed [RPM]	Motor speed reference. Actual speed depends on slip compensation being used (compensation set in <i>parameter 1-62 Slip Compensation</i>). If not used, actual speed is the value read in the display minus motor slip.
[1618]	Motor Thermal	Thermal load on the motor, calculated by the ETR function. See also <i>parameter group 1-9* Motor Temperature</i> .
[1622]	Torque [%]	Shows the actual torque produced, in percentage.
[1624]	Calibrated Stator Resistance	
[1630]	DC Link Voltage	Intermediate circuit voltage in the frequency converter.
[1631]	System Temp.	
[1632]	Brake Energy /s	Present brake power transferred to an external brake resistor. Stated as an instant value.
[1633]	Brake Energy /2 min	Brake power transferred to an external brake resistor. The average power is calculated continuously for the most recent 120 s.
[1634]	Heatsink Temp.	Present heat sink temperature of the frequency converter. The cutout limit is $95 \pm 5 \text{ }^\circ\text{C}$ ($203 \pm 9 \text{ }^\circ\text{F}$); cutting back in occurs at $70 \pm 5 \text{ }^\circ\text{C}$ ($158 \pm 9 \text{ }^\circ\text{F}$).
[1635]	Inverter Thermal	Percentage load of the inverters.
[1636]	Inv. Nom. Current	Nominal current of the frequency converter.
[1637]	Inv. Max. Current	Maximum current of the frequency converter.
[1638]	SL Controller State	State of the event executed by the control.
[1639]	Control Card Temp.	Temperature of the control card.
[1650]	External Reference	Sum of the external reference as a percentage, that is the sum of analog/pulse/bus.
[1652]	Feedback[Unit]	Reference value from programmed digital input(s).

0-20 Display Line 1.1 Small		
Option:	Function:	
[1653]	Digi Pot Reference	View the contribution of the digital potentiometer to the actual reference feedback.
[1654]	Feedback 1 [Unit]	View the value of feedback 1. See also <i>parameter group 20-0* FC Closed Loop</i> .
[1655]	Feedback 2 [Unit]	View the value of feedback 2. See also <i>parameter group 20-0* FC Closed Loop</i> .
[1656]	Feedback 3 [Unit]	View the value of feedback 3. See also <i>parameter group 20-0* FC Closed Loop</i> .
[1660]	Digital Input	Shows the status of the digital inputs. Signal low = 0; Signal high = 1. Regarding order, see <i>parameter 16-60 Digital Input</i> . Bit 0 is at the extreme right.
[1661]	Terminal 53 Switch Setting	Setting of input terminal 53. Current = 0; Voltage = 1.
[1662]	Analog Input 53	Actual value at input 53 either as a reference or protection value.
[1663]	Terminal 54 Switch Setting	Setting of input terminal 54. Current = 0; Voltage = 1.
[1664]	Analog Input 54	Actual value at input 54 either as reference or protection value.
[1665]	Analog Output 42 [mA]	Actual value at output 42 in mA. Use <i>parameter 6-50 Terminal 42 Output</i> to select the variable to be represented by output 42.
[1666]	Digital Output [bin]	Binary value of all digital outputs.
[1667]	Pulse Input #29 [Hz]	Actual value of the frequency applied at terminal 29 as a pulse input.
[1668]	Pulse Input #33 [Hz]	Actual value of the frequency applied at terminal 33 as a pulse input.
[1669]	Pulse Output #27 [Hz]	Actual value of pulses applied to terminal 27 in digital output mode.
[1670]	Pulse Output #29 [Hz]	Actual value of pulses applied to terminal 29 in digital output mode.
[1671]	Relay Output [bin]	View the setting of all relays.
[1672]	Counter A	View the present value of counter A.
[1673]	Counter B	View the present value of counter B.
[1675]	Analog In X30/11	Actual value of the signal on input X30/11 (general purpose I/O card. Optional).
[1676]	Analog In X30/12	Actual value of the signal on input X30/12 (general purpose I/O card. Optional).
[1677]	Analog Out X30/8 [mA]	Actual value at output X30/8 (general purpose I/O card. Optional). Use

0-20 Display Line 1.1 Small		
Option:	Function:	
		<i>parameter 6-60 Terminal X30/8 Output</i> to select the variable to be shown.
[1678]	Analog Out X45/1 [mA]	
[1679]	Analog Out X45/3 [mA]	
[1680]	Fieldbus CTW 1	Control word (CTW) received from the bus master.
[1682]	Fieldbus REF 1	Main reference value sent with control word via the serial communications network, for example from the BMS, PLC, or other master controller.
[1684]	Comm. Option STW	Extended fieldbus communication option status word.
[1685]	FC Port CTW 1	Control word (CTW) received from the bus master.
[1686]	FC Port REF 1	Status word (STW) sent to the bus master.
[1690]	Alarm Word	One or more alarms in a hex code (used for serial communications).
[1691]	Alarm Word 2	One or more alarms in a hex code (used for serial communications).
[1692]	Warning Word	One or more warnings in a hex code (used for serial communications).
[1693]	Warning Word 2	One or more warnings in a hex code (used for serial communications).
[1694]	Ext. Status Word	One or more status conditions in a hex code (used for serial communications).
[1695]	Ext. Status Word 2	One or more status conditions in a hex code (used for serial communications).
[1696]	Maintenance Word	The bits reflect the status for the programmed preventive maintenance events in <i>parameter group 23-1* Maintenance</i> .
[1699]	Ext. Status Word 3	
[1830]	Analog Input X42/1	Shows the value of the signal applied to terminal X42/1 on the analog I/O card.
[1831]	Analog Input X42/3	Shows the value of the signal applied to terminal X42/3 on the analog I/O card.
[1832]	Analog Input X42/5	Shows the value of the signal applied to terminal X42/5 on the analog I/O card.
[1833]	Analog Out X42/7 [V]	Shows the value of the signal applied to terminal X42/7 on the analog I/O card.

0-20 Display Line 1.1 Small		
Option:	Function:	
[1834]	Analog Out X42/9 [V]	Shows the value of the signal applied to terminal X42/9 on the analog I/O card.
[1835]	Analog Out X42/11 [V]	Shows the value of the signal applied to terminal X42/11 on the analog I/O card.
[1857]	Air Pressure to Flow Air Flow	
[1860]	Digital Input 2	
[1870]	Mains Voltage	
[1871]	Mains Frequency	
[1872]	Mains Imbalance	
[1875]	Rectifier DC Volt.	
[2117]	Ext. 1 Reference [Unit]	The value of the reference for extended closed-loop controller 1.
[2118]	Ext. 1 Feedback [Unit]	The value of the feedback signal for extended closed-loop controller 1.
[2119]	Ext. 1 Output [%]	The value of the output from extended closed-loop controller 1.
[2137]	Ext. 2 Reference [Unit]	The value of the reference for extended closed-loop controller 2.
[2138]	Ext. 2 Feedback [Unit]	The value of the feedback signal for extended closed-loop controller 2.
[2139]	Ext. 2 Output [%]	The value of the output from extended closed-loop controller 2.
[2157]	Ext. 3 Reference [Unit]	The value of the reference for extended closed-loop controller 3.
[2158]	Ext. 3 Feedback [Unit]	The value of the feedback signal for extended closed-loop controller 3.
[2159]	Ext. 3 Output [%]	The value of the output from extended closed-loop controller 3.
[2230]	No-Flow Power	The calculated no-flow power for the actual operating speed.
[2316]	Maintenance Text	
[2580]	Pack Status	Status for the operation of the pack controller.
[2581]	Compressor Status	Status for the operation of each individual compressor controlled by the pack controller.
[2587]	Inverse Interlock	
[2588]	Pack capacity [%]	
[2827]	Discharge Temperature	
[3038]	Pressure 1	
[3048]	Pressure 2	
[9920]	Fan Ctrl deltaT	

0-20 Display Line 1.1 Small		
Option:	Function:	
[9921]	Fan Ctrl Tmean	
[9922]	Fan Ctrl NTC Cmd	
[9923]	Fan Ctrl i-term	
[9924]	Rectifier Current	
[9952]	PC Debug 0	
[9953]	PC Debug 1	
[9954]	PC Debug 2	
[9961]	FPC Debug 0	
[9962]	FPC Debug 1	
[9963]	FPC Debug 2	
[9964]	FPC Debug 3	
[9965]	FPC Debug 4	

0-21 Display Line 1.2 Small		
Option:	Function:	
Application dependent	Select a variable for display in line 1, middle position. The options are the same as listed for <i>parameter 0-20 Display Line 1.1 Small</i> .	

0-22 Display Line 1.3 Small		
Option:	Function:	
Application dependent	Select a variable for display in line 1, right position. The options are the same as listed for <i>parameter 0-20 Display Line 1.1 Small</i> .	

0-23 Display Line 2 Large		
Option:	Function:	
Application dependent	Select a variable for display in line 2. The options are the same as listed for <i>parameter 0-20 Display Line 1.1 Small</i> .	

0-24 Display Line 3 Large		
Option:	Function:	
Application dependent	Select a variable for display in line 3. The options are the same as listed for <i>parameter 0-20 Display Line 1.1 Small</i> .	

0-25 My Personal Menu		
Array [20]		
Range:	Function:	
Size related*	[0 - 9999]	Define up to 20 parameters to appear in the Q1 Personal Menu, accessible via the [Quick Menu] key on the LCP. The parameters are displayed in the Q1 Personal Menu in the order they are programmed into this array parameter. Delete parameters by setting the value to 0000. For example, this can be used to provide quick, simple access to just 1 or up to 20 parameters which require changing on a regular basis (for example, for plant maintenance reasons) or by an OEM to enable simple commissioning of their equipment.

The relation depends on the type of unit selected in *parameter 0-30 Custom Readout Unit*:

Unit type	Speed relation
Dimensionless	Linear
Speed	
Flow, volume	
Flow, mass	
Velocity	
Length	
Temperature	
Pressure	Quadratic
Power	Cubic

Table 3.2 Speed Relations for Different Unit Types

3.2.3 0-3* LCP Custom Readout

It is possible to customize the display elements for various purposes:

- Custom readout. Value proportional to speed (linear, squared, or cubed depending on unit selected in *parameter 0-30 Custom Readout Unit*).
- Display text. Text string stored in a parameter.

Custom readout

The calculated value to be shown is based on the settings in:

- *Parameter 0-30 Custom Readout Unit*.
- *Parameter 0-31 Custom Readout Min Value* (linear only).
- *Parameter 0-32 Custom Readout Max Value*.
- *Parameter 4-13 Motor Speed High Limit [RPM]*.
- *Parameter 4-14 Motor Speed High Limit [Hz]*.
- Actual speed.

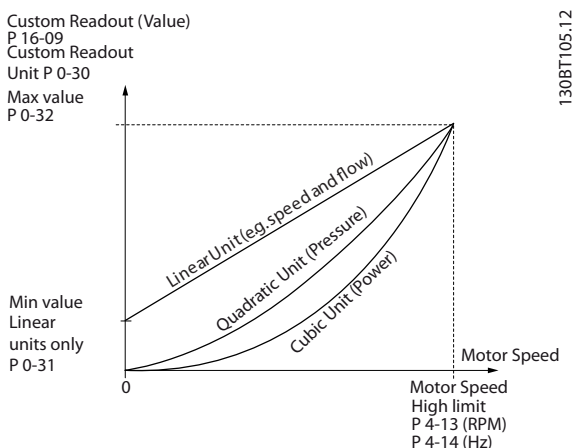

Illustration 3.3 Custom Readout

0-30 Custom Readout Unit		
Option:	Function:	
		Program a value to be shown in the LCP display. The value has a linear, squared, or cubed relation to speed. This relation depends on the unit selected (see <i>Table 3.2</i>). The actual calculated value can be read in <i>parameter 16-09 Custom Readout</i> , and/or shown in the display by selecting [1609] <i>Custom Readout</i> in <i>parameter 0-20 Display Line 1.1 Small</i> to <i>parameter 0-24 Display Line 3 Large</i> .
[0]		
[1] *	%	
[5]	PPM	
[10]	1/min	
[11]	RPM	
[12]	Pulse/s	
[20]	l/s	
[21]	l/min	
[22]	l/h	
[23]	m ³ /s	
[24]	m ³ /min	
[25]	m ³ /h	
[30]	kg/s	
[31]	kg/min	
[32]	kg/h	
[33]	t/min	
[34]	t/h	
[40]	m/s	
[41]	m/min	
[45]	m	
[60]	°C	
[70]	mbar	
[71]	bar	
[72]	Pa	
[73]	kPa	
[74]	m WG	
[80]	kW	
[120]	GPM	

0-30 Custom Readout Unit		
Option:	Function:	
[121]	gal/s	
[122]	gal/min	
[123]	gal/h	
[124]	CFM	
[125]	ft ³ /s	
[126]	ft ³ /min	
[127]	ft ³ /h	
[130]	lb/s	
[131]	lb/min	
[132]	lb/h	
[140]	ft/s	
[141]	ft/min	
[145]	ft	
[160]	°F	
[170]	psi	
[171]	lb/in ²	
[172]	in WG	
[173]	ft WG	
[180]	HP	

0-31 Custom Readout Min Value		
Range:	Function:	
Size related* [0 - 0 CustomReadoutUnit]	This parameter allows selection of the minimum value of the custom-defined readout (occurs at zero speed). It is only possible to select a value different from 0 when selecting a linear unit in <i>parameter 0-30 Custom Readout Unit</i> . For quadratic and cubic units the minimum value is 0.	

0-32 Custom Readout Max Value		
Range:	Function:	
100 Custom-ReadoutUnit*	[par. 0-31 - 999999.99 CustomReadoutUnit]	This parameter sets the maximum value to be shown when the speed of the motor has reached the set value for <i>parameter 4-13 Motor Speed High Limit [RPM]</i> or <i>parameter 4-14 Motor Speed High Limit [Hz]</i> (depends on setting in <i>parameter 0-02 Motor Speed Unit</i>).

0-37 Display Text 1		
Range:	Function:	
0* [0 - 25]	In this parameter, it is possible to write an individual text string to be shown in the LCP or to be read via serial communication. To show the text permanently, select [37] <i>Display Text 1</i> in 1 of the following parameters:	

0-37 Display Text 1		
Range:	Function:	
	<ul style="list-style-type: none"> Parameter 0-20 Display Line 1.1 Small. Parameter 0-21 Display Line 1.2 Small. Parameter 0-22 Display Line 1.3 Small. Parameter 0-23 Display Line 2 Large. Parameter 0-24 Display Line 3 Large. Parameter 0-37 Display Text 1. <p>Changing <i>parameter 12-08 Host Name</i> changes <i>parameter 0-37 Display Text 1</i> - but not vice versa.</p>	

0-38 Display Text 2		
Range:	Function:	
0* [0 - 25]	<p>In this parameter, it is possible to write an individual text string to show in the LCP or to be read via serial communication.</p> <p>To show the text permanently, select [38] <i>Display Text 2</i> in:</p> <ul style="list-style-type: none"> Parameter 0-20 Display Line 1.1 Small. Parameter 0-21 Display Line 1.2 Small. Parameter 0-22 Display Line 1.3 Small. Parameter 0-23 Display Line 2 Large. Parameter 0-24 Display Line 3 Large. <p>Press [▲] or [▼] to change a character. Press [◀] and [▶] to move the cursor. When a character is highlighted by the cursor, this character can be changed. A character can be inserted by placing the cursor between 2 characters and pressing [▲] or [▼].</p>	

0-39 Display Text 3		
Range:	Function:	
0* [0 - 25]	<p>In this parameter, it is possible to write an individual text string to show in the LCP or to be read via serial communication. To show the text permanently, select display text 3 in <i>parameter 0-20 Display Line 1.1 Small</i>, <i>parameter 0-21 Display Line 1.2 Small</i>, <i>parameter 0-22 Display Line 1.3 Small</i>, <i>parameter 0-23 Display Line 2 Large</i>, or <i>parameter 0-24 Display Line 3 Large</i>. Press [▲] or [▼] to change a character. Press [◀] and [▶] to move the cursor. When a character is highlighted by the cursor, this character can be changed. A character can be inserted by placing the cursor between 2 characters and pressing [▲] or [▼].</p>	

3.2.4 0-4* LCP Keypad

Enable, disable, and password protect individual keys on the LCP.

0-40 [Hand on] Key on LCP		
Option:	Function:	
[0]	Disabled	Select to disable the key.
[1] *	Enabled	[Hand On] key enabled.
[2]	Password	Avoid unauthorized start in hand-on mode. If <i>parameter 0-40 [Hand on] Key on LCP</i> is included in <i>My Personal Menu</i> , define the password in <i>parameter 0-65 Personal Menu Password</i> . Otherwise, define the password in <i>parameter 0-60 Main Menu Password</i> .
[9]	Enabled, ref = 0	

0-41 [Off] Key on LCP		
Option:	Function:	
[0]	Disabled	Select to disable the key.
[1] *	Enabled	[Off] key is enabled.
[2]	Password	Avoid unauthorized stop. If <i>parameter 0-41 [Off] Key on LCP</i> is included in <i>My Personal Menu</i> , define the password in <i>parameter 0-65 Personal Menu Password</i> . Otherwise, define the password in <i>parameter 0-60 Main Menu Password</i> .

0-42 [Auto on] Key on LCP		
Option:	Function:	
[0]	Disabled	Select to disable the key.
[1] *	Enabled	[Auto On] key is enabled.
[2]	Password	Avoid unauthorized start in auto-on mode. If <i>parameter 0-42 [Auto on] Key on LCP</i> is included in <i>My Personal Menu</i> , define the password in <i>parameter 0-65 Personal Menu Password</i> . Otherwise, define the password in <i>parameter 0-60 Main Menu Password</i> .

0-43 [Reset] Key on LCP		
Option:	Function:	
[0]	Disabled	Select to disable the key.
[1] *	Enabled	[Reset] key is enabled.
[2]	Password	Avoid unauthorized resetting. If <i>parameter 0-43 [Reset] Key on LCP</i> is included in <i>parameter 0-25 My Personal Menu</i> , define the password in <i>parameter 0-65 Personal Menu Password</i> . Otherwise, define the password in <i>parameter 0-60 Main Menu Password</i> .

3.2.5 0-5* Copy/Save

Copy parameters from and to the LCP. Use these parameters for saving and copying set-ups from 1 frequency converter to another.

0-50 LCP Copy		
Option:	Function:	
		NOTICE This parameter cannot be adjusted while the motor is running.
[0] *	No copy	
[1]	All to LCP	Copies all parameters in all set-ups from the frequency converter memory to the LCP memory. For service purposes, copy all parameters to the LCP after commissioning.
[2]	All from LCP	Copies all parameters in all set-ups from the LCP memory to the frequency converter memory.
[3]	Size indep. from LCP	Copies only the parameters that are independent of the motor size. Use the latest selection to program several frequency converters with the same function without disturbing motor data which are already set.
[10]	Delete LCP copy data	

0-51 Set-up Copy		
Option:	Function:	
[0] *	No copy	No function.
[1]	Copy to set-up 1	Copies all parameters in the present programming set-up (defined in <i>parameter 0-11 Programming Set-up</i>) to set-up 1.
[2]	Copy to set-up 2	Copies all parameters in the present programming set-up (defined in <i>parameter 0-11 Programming Set-up</i>) to set-up 2.
[3]	Copy to set-up 3	Copies all parameters in the present programming set-up (defined in <i>parameter 0-11 Programming Set-up</i>) to set-up 3.
[4]	Copy to set-up 4	Copies all parameters in the present programming set-up (defined in <i>parameter 0-11 Programming Set-up</i>) to set-up 4.
[9]	Copy to all	Copies the parameters in the present set-up to each of the set-ups 1 to 4.

3.2.6 0-6* Password

0-60 Main Menu Password		
Range:	Function:	
100*	[-9999 - 9999]	Define the password for access to the Main Menu via the [Main Menu] key. If <i>parameter 0-61 Access to Main Menu w/o Password</i> is set to [0] Full access, this parameter is ignored.

0-61 Access to Main Menu w/o Password		
Option:	Function:	
[0] *	Full access	Disables the password defined in <i>parameter 0-60 Main Menu Password</i> . If this option is selected, <i>parameter 0-60 Main Menu Password</i> , <i>parameter 0-65 Personal Menu Password</i> , and <i>parameter 0-66 Access to Personal Menu w/o Password</i> are ignored.
[1]	LCP: Read only	Prevents unauthorized editing of <i>Main Menu</i> parameters.
[2]	LCP: No access	Prevents unauthorized viewing and editing of <i>Main Menu</i> parameters.
[3]	Bus: Read only	
[4]	Bus: No access	
[5]	All: Read only	
[6]	All: No access	

0-65 Personal Menu Password		
Range:	Function:	
200*	[-9999 - 9999]	Define the password for access to <i>My Personal Menu</i> via the [Quick Menu] key. If <i>parameter 0-66 Access to Personal Menu w/o Password</i> is set to [0] Full access, this parameter is ignored.

0-66 Access to Personal Menu w/o Password		
If <i>parameter 0-61 Access to Main Menu w/o Password</i> is set to [0] Full access, this parameter is ignored.		
Option:	Function:	
[0] *	Full access	Disables the password defined in <i>parameter 0-65 Personal Menu Password</i> .
[1]	LCP: Read only	Prevents unauthorized editing of <i>My Personal Menu</i> -parameters.
[2]	LCP: No access	Prevents unauthorized viewing and editing of <i>My Personal Menu</i> -parameters.
[3]	Bus: Read only	
[4]	Bus: No access	
[5]	All: Read only	
[6]	All: No access	

0-67 Bus Password Access		
Range:	Function:	
0*	[0 - 9999]	Use this parameter to unlock the frequency converter via fieldbus or MCT 10 Set-up Software.

3.2.7 0-7* Clock Settings

Set the time and date of the internal clock. The internal clock can be used for timed actions, energy log, trend analysis, date/time stamps on alarms, logged data, preventive maintenance, and so on.

It is possible to program the clock for daylight saving time/summertime, weekly working days/non-working days including 20 exceptions (holidays, and so on). Although the clock settings can be set via the LCP, they can also be set along with timed actions and preventative maintenance functions using the MCT 10 Set-up Software tool.

NOTICE

The frequency converter has no back-up of the clock function and the set date/time resets to default (2000-01-01 00:00) after a power-down unless a real-time clock-module with back-up is installed. If no module with back-up is installed, only use the clock function if the frequency converter is integrated into the BMS using serial communications, with the BMS maintaining synchronization of control equipment clock times. In *parameter 0-79 Clock Fault*, it is possible to program for a warning if the clock has not been set properly, for example after a power down.

NOTICE

If mounting VLT® Analog I/O Option MCB 109, a battery back-up of the date and time is included.

0-70 Set Date and Time		
Range:	Function:	
Size related*	[0 - 0]	Sets the date and time of the internal clock. The format to be used is set in <i>parameter 0-71 Date Format</i> and <i>parameter 0-72 Time Format</i> .

0-71 Date Format		
Option:	Function:	
		Sets the date format to be used in the LCP.
[0]	YYYY-MM-DD	
[1]	DD-MM-YYYY	
[2]	MM/DD/YYYY	

0-72 Time Format		
Option:	Function:	
		Sets the time format to be used in the LCP.
[0]	24 h	
[1]	12 h	

0-74 DST/Summertime		
Option:	Function:	
		Select how to handle daylight saving time/summertime. For manual setting of DST/summertime, enter the start date and end date in <i>parameter 0-76 DST/Summertime Start</i> and <i>parameter 0-77 DST/Summertime End</i> .
[0] *	Off	
[2]	Manual	

0-76 DST/Summertime Start		
Range:	Function:	
Size related*	[0 - 0]	Sets the date and time when DST/summertime starts. The date is programmed in the format selected in <i>parameter 0-71 Date Format</i> .

0-77 DST/Summertime End		
Range:	Function:	
Size related*	[0 - 0]	Sets the date and time when DST/summertime ends. The date is programmed in the format selected in <i>parameter 0-71 Date Format</i> .

0-79 Clock Fault		
Option:	Function:	
		Enables or disables the clock warning when the clock has not been set, or has been reset due to a power-down and no back-up is installed. If VLT® Analog I/O Option MCB 109 is installed, [1] <i>Enabled</i> is default.
[0] *	Disabled	
[1]	Enabled	

0-81 Working Days		
Array [7] Array with 7 elements [0]–[6] shown below the parameter number in the display. Press [OK] and step between elements with [▲] and [▼].		
Option:	Function:	
		Set for each weekday if it is a working day or a non-working day. First element of the array is Monday. The working days are used for timed actions.
[0]	No	
[1]	Yes	

0-82 Additional Working Days		
Array [5] Array with 5 elements [0]–[4] shown below the parameter number in the display. Press [OK] and step between elements with [▲] and [▼].		
Range:	Function:	
Size related*	[0 - 0]	Defines dates for additional working days that would normally be non-working days according to <i>parameter 0-81 Working Days</i> .

0-83 Additional Non-Working Days		
Array [15] Array with 15 elements [0]–[14] shown below the parameter number in the display. Press [OK] and step between elements with [▲] and [▼].		
Range:	Function:	
Size related*	[0 - 0]	Defines dates for additional working days that would normally be non-working days according to <i>parameter 0-81 Working Days</i> .

0-89 Date and Time Readout		
Range:	Function:	
0*	[0 - 25]	Shows the current date and time. The date and time is updated continuously. The clock does not begin counting until a setting different from default has been made in <i>parameter 0-70 Set Date and Time</i> .

3.3 Parameters: 1-** Load and Motor

3.3.1 1-0* General Settings

Define whether the frequency converter operates in open loop or closed loop.

1-00 Configuration Mode		
Option:	Function:	
	<p>NOTICE</p> <p>This parameter cannot be adjusted while the motor is running.</p> <p>NOTICE</p> <p>When set to [3] Closed Loop, the commands reversing and start reversing do not reverse the motor direction.</p>	
[0]	Speed Open Loop	<p>Motor speed is determined by applying a speed reference or by setting the speed when in hand-on mode.</p> <p>Open loop is also used if the frequency converter is part of a closed-loop control system based on an external PID controller providing a speed reference signal as output.</p>
[3]	Process Closed Loop	<p>Motor speed is determined by a reference from the built-in PID controller varying the motor speed as in a closed-loop control process (for example constant pressure or flow). Configure the PID controller in <i>parameter group 20-** Feedback</i> or via the <i>Function Set-ups</i> accessed by pressing [Quick Menu].</p>

1-03 Torque Characteristics		
Option:	Function:	
[0]	Compressor CT	<p>For speed control of screw and scroll compressors. Provides a voltage which is optimized for a constant torque load characteristic of the motor in the entire range down to 10 Hz.</p>
[1]	Condenser VT	<p>For speed control of centrifugal pumps and fans. Also to be used when controlling more than 1 motor from the same frequency converter (for example, multiple condenser fans or cooling tower fans). Provides a voltage which is optimized for a squared torque load characteristic of the motor.</p>
[2]	Compressor AEO CT	<p>For optimum energy-efficient speed control of screw and scroll compressors. Provides a voltage which is optimized for a constant torque load characteristic of the motor in the entire range down to 15 Hz. In addition, the AEO feature adapts the voltage exactly to the current load situation, thereby reducing energy consumption and audible noise from</p>

1-03 Torque Characteristics		
Option:	Function:	
		<p>the motor. To obtain optimum performance, set the motor power factor cos phi correctly. This value is set in <i>parameter 14-43 Motor Cosphi</i>. The parameter has a default value which is automatically adjusted when the motor data is programmed. These settings ensure optimum motor voltage. If the motor power factor cos phi requires tuning, an AMA function can be carried out using <i>parameter 1-29 Automatic Motor Adaptation (AMA)</i>. It is rarely necessary to adjust the motor power factor parameter manually.</p>
[3]	Single fan/pump AEO VT	<p>For optimum energy-efficient speed control of centrifugal pumps and fans. Provides a voltage optimized for a squared torque load characteristic of the motor. In addition, the AEO feature adapts the voltage exactly to the current load situation, thereby reducing energy consumption and audible noise from the motor. To obtain optimum performance, set the motor power factor cos phi correctly. This value is set in <i>parameter 14-43 Motor Cosphi</i>. The parameter has a default value and is automatically adjusted when the motor data is programmed. These settings ensure optimum motor voltage. If the motor power factor cos phi requires tuning, an AMA function can be carried out using <i>parameter 1-29 Automatic Motor Adaptation (AMA)</i>. It is rarely necessary to adjust the motor power factor parameter manually.</p>

1-06 Clockwise Direction			
Option:	Function:		
		<p>NOTICE</p> <p>This parameter cannot be adjusted while the motor is running.</p> <p>This parameter defines the term clockwise corresponding to the LCP direction arrow. Used for easy change of direction of shaft rotation without swapping motor wires.</p>	
[0]	*	Normal	<p>The motor shaft turns in clockwise direction when the frequency converter is connected U⇒U, V⇒V, and W⇒W to the motor.</p>
[1]		Inverse	<p>Motor shaft turns in counterclockwise direction when the frequency converter is connected U⇒U, V⇒V, and W⇒W to the motor.</p>

3.3.2 1-1* Motor Selection

3.3.3 SynRM Motor Set-up with VVC+

This section describes how to set up a SynRM motor with VVC+.

NOTICE

The SmartStart wizard covers the basic configuration of SynRM motors.

Initial programming steps

To activate SynRM motor operation, select [5] Sync. Reluctance in parameter 1-10 Motor Construction.

Programming motor data

After performing the initial programming steps, the SynRM motor-related parameters in parameter groups 1-2* Motor Data, 1-3* Adv. Motor Data, and 1-4* Adv. Motor Data II are active.

Use the motor nameplate data and the motor datasheet to program the following parameters in the order listed:

- Parameter 1-23 Motor Frequency.
- Parameter 1-24 Motor Current.
- Parameter 1-25 Motor Nominal Speed.
- Parameter 1-26 Motor Cont. Rated Torque.

Run a complete AMA using parameter 1-29 Automatic Motor Adaptation (AMA) [1] Enable Complete AMA or enter the following parameters manually:

- Parameter 1-30 Stator Resistance (Rs).
- Parameter 1-37 d-axis Inductance (Ld).
- Parameter 1-44 d-axis Inductance Sat. (LdSat).
- Parameter 1-45 q-axis Inductance Sat. (LqSat).
- Parameter 1-48 Inductance Sat. Point.

Application-specific adjustments

Start the motor at nominal speed. If the application does not run well, check the VVC+ SynRM settings. Table 3.3 provides application-specific recommendations:

Application	Settings
Low-inertia applications $I_{Load}/I_{Motor} < 5$	Increase parameter 1-17 Voltage filter time const. by factor 5–10. Reduce parameter 1-14 Damping Gain. Reduce parameter 1-66 Min. Current at Low Speed (<100%).
Low-inertia applications $50 > I_{Load}/I_{Motor} > 5$	Keep the default values.
High-inertia applications $I_{Load}/I_{Motor} > 50$	Increase parameter 1-14 Damping Gain, parameter 1-15 Low Speed Filter Time Const., and parameter 1-16 High Speed Filter Time Const.

Application	Settings
High-load at low speed <30% (rated speed)	Increase parameter 1-17 Voltage filter time const. Increase parameter 1-66 Min. Current at Low Speed to adjust the starting torque. 100% current provides nominal torque as starting torque. Working at a current level higher than 100% for a prolonged time can cause the motor to overheat.
Dynamic applications	Increase parameter 14-41 AEO Minimum Magnetisation for highly dynamic applications. Adjusting parameter 14-41 AEO Minimum Magnetisation ensures a good balance between energy efficiency and dynamics. Adjust parameter 14-42 Minimum AEO Frequency to specify the minimum frequency at which the frequency converter should use minimum magnetization.
Motor sizes less than 18 kW	Avoid short ramp-down times.

Table 3.3 Recommendations for Various Applications

If the motor starts oscillating at a certain speed, increase parameter 1-14 Damping Gain. Increase the damping gain value in small steps. Depending on the motor, this parameter can be set to 10–100% higher than the default value.

1-10 Motor Construction		
Select the motor construction type.		
	Option:	Function:
[0] *	Asynchron	For asynchronous motors.
[1]	PM, non salient SPM	Use for non-salient PM motors.
[5]	Sync. Reluctance	Use for synchronous reluctance motors. NOTICE This option has the following firmware version limitations: <ul style="list-style-type: none"> • Version 1.42 – use this option only when flying start is enabled in parameter 1-73 Flying Start.

3.3.4 1-14 to 1-17 VVC⁺ PM

The default control parameters for VVC⁺ PM motor control core are optimized for applications and inertia load in the range of $50 > J_l/J_m > 5$. J_l is load inertia from the application and J_m is machine inertia.

For low inertia applications ($J_l/J_m < 5$), it is recommended that *parameter 1-17 Voltage filter time const.* is increased with a factor of 5–10. Sometimes, *parameter 14-08 Damping Gain Factor* should also be reduced to improve performance and stability.

For high-inertia applications ($J_l/J_m > 50$), increase *parameter 1-15 Low Speed Filter Time Const.* and *parameter 1-16 High Speed Filter Time Const.* to improve performance and stability.

For high load at low speed (<30% of rated speed), it is recommended that *parameter 1-17 Voltage filter time const.* is increased due to non-linearity in the inverter at low speed.

1-14 Damping Gain		
Range:		Function:
120 %*	[0 - 250 %]	The damping gain stabilizes the PM machine to run the PM machine smooth and stable. The value of damping gain controls the dynamic performance of the PM machine. High damping gain gives low dynamic performance, and low damping gain gives high dynamic performance. The dynamic performance is related to the machine data and load type. If the damping gain is too high or low, the control becomes unstable.

1-15 Low Speed Filter Time Const.		
Range:		Function:
Size related*	[0.01 - 20 s]	High-pass filter damping time constant determines the response time to load steps. Obtain quick control through a short damping time constant. However, if this value is too low, the control becomes unstable. This time constant is used below 10% rated speed.

1-16 High Speed Filter Time Const.		
Range:		Function:
Size related*	[0.01 - 20 s]	High-pass filter damping time constant determines the response time to load steps. Obtain quick control through a short damping time constant. However, if this value is too low, the control becomes unstable. This time constant is used above 10% rated speed.

1-17 Voltage filter time const.		
Range:		Function:
Size related*	[0.001 - 1 s]	Supply voltage filter time constant is used for reducing the influence of high frequency ripples and system resonances in the calculation of machine supply voltage. Without this filter, the ripples in the currents can distort the calculated voltage and affect the stability of the system.

3.3.5 1-2* Motor Data

This parameter group contains input data from the nameplate on the connected motor.

NOTICE

Changing the value of these parameters affects the setting of other parameters.

NOTICE

The following parameters have no effect when *parameter 1-10 Motor Construction* is set to [1] PM, non-salient SPM, [2] PM, salient IPM, [5] Sync. Reluctance:

- *Parameter 1-20 Motor Power [kW]*
- *Parameter 1-21 Motor Power [HP]*
- *Parameter 1-22 Motor Voltage*
- *Parameter 1-23 Motor Frequency*

1-20 Motor Power [kW]		
Range:		Function:
Size related*	[0.09 - 3000.00 kW]	Enter the nominal motor power in kW according to the motor nameplate data. The default value corresponds to the nominal rated output of the unit. Depending on the selections made in <i>parameter 0-03 Regional Settings</i> , either <i>parameter 1-20 Motor Power [kW]</i> or <i>parameter 1-21 Motor Power [HP]</i> is made invisible.

1-21 Motor Power [HP]		
Range:		Function:
Size related*	[0.09 - 3000.00 hp]	<p>NOTICE This parameter cannot be adjusted while the motor is running.</p> <p>Enter the nominal motor power in hp according to the motor nameplate data. The default value corresponds to the nominal rated output of the unit. Depending on the selections made in <i>parameter 0-03 Regional Settings</i>, either <i>parameter 1-20 Motor Power [kW]</i> or <i>parameter 1-21 Motor Power [HP]</i> is made invisible.</p>

1-22 Motor Voltage		
Range:		Function:
Size related*	[10 - 1000 V]	Enter the nominal motor voltage according to the motor nameplate data. The default value corresponds to the nominal rated output of the frequency converter.

1-23 Motor Frequency		
Range:		Function:
Size related*	[20 - 1000 Hz]	<p>NOTICE This parameter cannot be adjusted while the motor is running.</p> <p>Select the motor frequency value from the motor nameplate data. For 87 Hz operation with 230/400 V motors, set the nameplate data for 230 V/50 Hz. Adapt <i>parameter 4-13 Motor Speed High Limit [RPM]</i> and <i>parameter 3-03 Maximum Reference</i> to the 87 Hz application.</p>

1-24 Motor Current		
Range:		Function:
Size related*	[0.10 - 10000.00 A]	<p>NOTICE This parameter cannot be adjusted while the motor is running.</p> <p>Enter the nominal motor current value from the motor nameplate data. The data is used for calculating motor torque, motor thermal protection, and so on.</p>

1-25 Motor Nominal Speed		
Range:		Function:
Size related*	[100 - 60000 RPM]	<p>NOTICE This parameter cannot be adjusted while the motor is running.</p> <p>Enter the nominal motor speed value from the motor nameplate data. The data is used for calculating automatic motor compensations.</p>

1-26 Motor Cont. Rated Torque		
Range:		Function:
Size related*	[0.1 - 10000 Nm]	Enter the value from the motor nameplate data. The default value corresponds to the nominal rated output. This parameter is available when <i>parameter 1-10 Motor Construction</i> is set to [1] PM, non-salient SPM, that is the parameter is valid for PM and non-salient SPM motors only.

1-28 Motor Rotation Check	
Option:	Function:
	<p>⚠ WARNING HIGH VOLTAGE Frequency converters contain high voltage when connected to AC mains input, DC supply, or load sharing.</p> <ul style="list-style-type: none"> Remove mains power before disconnecting motor phase cables. <p>NOTICE Once the motor rotation check is enabled, the display shows: <i>Note! Motor may run in wrong direction.</i> Pressing [OK], [Back], or [Cancel] dismisses the message and shows a new message: <i>Press [Hand On] to start the motor. Press [Cancel] to abort.</i> Pressing [Hand On] starts the motor at 5 Hz in forward direction and the display shows: <i>Motor is running.</i> Check if motor rotation direction is correct. Press [Off] to stop the motor. Pressing [Off] stops the motor and resets <i>parameter 1-28 Motor Rotation Check</i>. If motor rotation direction is incorrect, interchange 2 motor phase cables.</p> <p>Following installation and connection of the motor, this function allows the correct motor rotation direction to be verified. Enabling this function overrides any bus commands or digital</p>

1-28 Motor Rotation Check		
Option:	Function:	
		inputs, except external interlock and Safe Torque Off (STO) (if included).
[0]	Off	Motor rotation check is not active.
[1]	Enabled	Motor rotation check is enabled.

1-29 Automatic Motor Adaptation (AMA)		
Option:	Function:	
		<p>NOTICE</p> <p>This parameter cannot be adjusted while the motor is running.</p> <p>The AMA function optimizes dynamic motor performance by automatically optimizing the advanced motor parameters (parameter 1-30 Stator Resistance (R_s) to parameter 1-35 Main Reactance (X_h)) at motor standstill.</p>
[0] *	Off	No function.
[1]	Enable Complete AMA	Performs AMA of the stator resistance R_s , the rotor resistance R_r , the stator leakage reactance X_1 , the rotor leakage reactance X_2 and the main reactance X_h .
[2]	Enable Reduced AMA	Performs a reduced AMA of the stator resistance R_s in the system only. Select this option if an LC filter is used between the frequency converter and the motor.

Activate the AMA function by pressing [Hand On] after selecting [1] Enable complete AMA or [2] Enable reduced AMA. See also the section Automatic Motor Adaptation in the design guide. After a normal sequence, the display reads: Press [OK] to finish AMA. After pressing [OK], the frequency converter is ready for operation.

NOTICE

- For the best adaptation of the frequency converter, run AMA on a cold motor.
- AMA cannot be performed while the motor is running.

NOTICE

Avoid generating external torque during AMA.

NOTICE

If 1 of the settings in parameter group 1-2* Motor Data is changed, parameter 1-30 Stator Resistance (R_s) to parameter 1-39 Motor Poles return to default settings.

NOTICE

Only run complete AMA without filter, and only run reduced AMA with filter.

See section Automatic Motor Adaptation in the design guide.

3.3.6 1-3* Adv. Motor Data

Parameters for advanced motor data. The motor data in parameter 1-30 Stator Resistance (R_s) to parameter 1-39 Motor Poles must match the relevant motor to run the motor optimally. The default settings are figures based on common motor parameter values from normal standard motors. If the motor parameters are not set correctly, a malfunction of the frequency converter system may occur. If the motor data is not known, running an AMA (automatic motor adaptation) is recommended. See the Automatic Motor Adaptation section in the design guide. The AMA sequence adjusts all motor parameters except the moment of inertia of the rotor and the iron loss resistance (parameter 1-36 Iron Loss Resistance (R_{fe})).

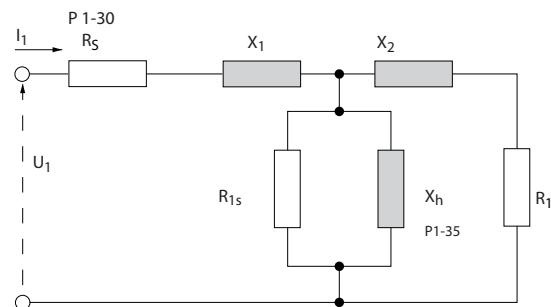

Illustration 3.4 Motor Equivalent Diagram for an Asynchronous Motor

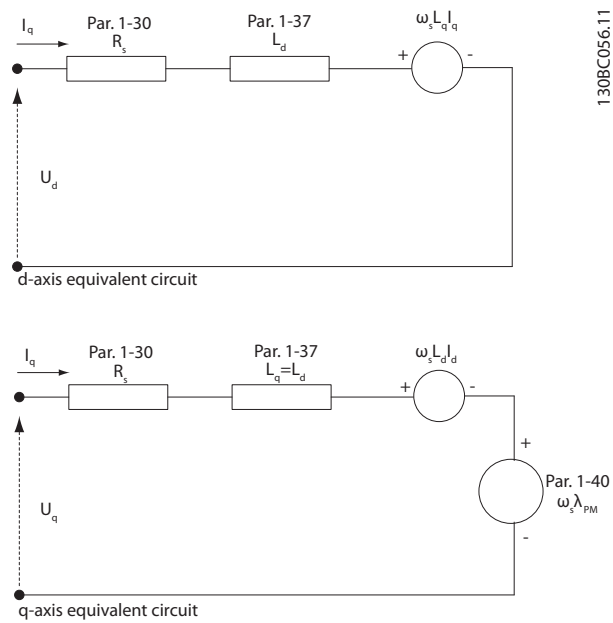

Illustration 3.5 Motor Equivalent Circuit Diagram for a PM Non-salient Motor

1-30 Stator Resistance (Rs)		
Range:	Function:	
Size related* [0.0140 - 140.0000 Ohm]	<p>NOTICE This parameter cannot be adjusted while the motor is running.</p> <p>For PM motors, see the description in parameter 1-37 d-axis Inductance (Ld). Set the stator resistance value. Enter the value from a motor datasheet or perform an AMA on a cold motor.</p>	

1-31 Rotor Resistance (Rr)		
Range:	Function:	
Size related* [0.0100 - 100.0000 Ohm]	<p>Fine-tuning R_r improves shaft performance. Set the rotor resistance value using 1 of these methods:</p> <ul style="list-style-type: none"> Run an AMA on a cold motor. The frequency converter measures the value from the motor. All compensations are reset to 100%. Enter the R_r value manually. Obtain the value from the motor supplier. Use the R_r default setting. The frequency converter establishes the setting on the basis of the motor nameplate data. 	

1-35 Main Reactance (Xh)		
Range:	Function:	
Size related* [1.0000 - 10000.0000 Ohm]	<p>NOTICE This parameter cannot be adjusted while running.</p> <p>NOTICE Parameter 1-35 Main Reactance (Xh) does not have effect when parameter 1-10 Motor Construction=[1] PM, non-salient SPM.</p> <p>Set the main reactance of the motor using 1 of these methods:</p> <ul style="list-style-type: none"> Run an AMA on a cold motor. The frequency converter measures the value from the motor. Enter the X_h value manually. Obtain the value from the motor supplier. Use the X_h default setting. The frequency converter establishes the setting on the basis of the motor nameplate data. 	

1-36 Iron Loss Resistance (Rfe)		
Range:	Function:	
Size related* [0 - 10000.0000 Ohm]	<p>NOTICE This parameter cannot be adjusted while the motor is running.</p> <p>Enter the equivalent iron loss resistance (R_{Fe}) value to compensate for iron losses in the motor. The R_{Fe} value cannot be found by performing an AMA. The R_{Fe} value is especially important in torque control applications. If R_{Fe} is unknown, leave parameter 1-36 Iron Loss Resistance (Rfe) on default setting.</p>	

1-37 d-axis Inductance (Ld)		
Range:		Function:
Size related*	[0.000 - 1000.000 mH]	<p>NOTICE</p> <p>This parameter is only active when <i>parameter 1-10 Motor Construction</i> is set to [1] PM, non-salient SPM.</p> <p>Enter the value of the d-axis inductance. Obtain the value from the PM motor datasheet.</p>

For asynchronous motor, stator resistance, and d-axis inductance values are normally described in technical specifications as between line and common (startpoint). For PM motors, they are typically described in technical specifications as between line-line. PM motors are typically built for star connection.

<i>Parameter 1-30 Stator Resistance (Rs)</i> (line to common).	This parameter gives stator winding resistance (Rs) similar to asynchronous motor stator resistance. The stator resistance is defined for line-to-common measurement. For line-line data, where stator resistance is measured between any 2 lines, divide by 2.
<i>Parameter 1-37 d-axis Inductance (Ld)</i> (line to common).	This parameter gives direct axis inductance of the PM motor. The d-axis inductance is defined for phase-to-common measurement. For line-line data, where stator resistance is measured between any 2 lines, divide by 2.
<i>Parameter 1-40 Back EMF at 1000 RPM</i> RMS (line to line value).	This parameter gives back EMF across stator terminal of PM motor at 1000 RPM mechanical speed specifically. It is defined between line-to-line and expressed in RMS value.

Table 3.4 Parameters Related to PM Motors

NOTICE

Motor manufacturers provide values for stator resistance (*parameter 1-30 Stator Resistance (Rs)*) and d-axis inductance (*parameter 1-37 d-axis Inductance (Ld)*) in technical specifications as between line and common (startpoint) or line between line. There is no general standard. The different set-ups of stator winding resistance and induction are shown in *Illustration 3.6*. Danfoss frequency converters always require the line-to-common value. The back EMF of a PM motor is defined as induced EMF developed across any of 2 phases of stator winding of a free-running motor. Danfoss frequency converters always require the line-to-line RMS value measured at 1000 RPM, mechanical speed of rotation. This is shown in *Illustration 3.7*.

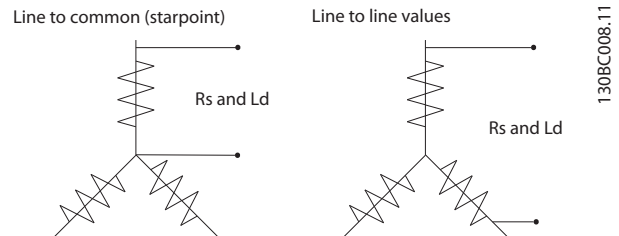

Illustration 3.6 Stator Winding Set-ups

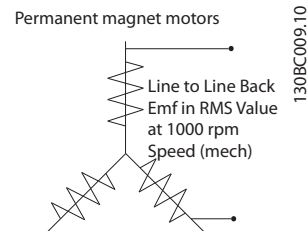

Illustration 3.7 Machine Parameter Definitions of Back EMF of PM Motors

1-38 q-axis Inductance (Lq)		
Range:		Function:
Size related*	[0.000 - 1000 mH]	<p>NOTICE</p> <p>This parameter cannot be adjusted while the motor is running.</p> <p>Set the value of the q-axis inductance. See the motor datasheet.</p>

1-39 Motor Poles														
Range:		Function:												
Size related*	[2 - 100]	<p>NOTICE This parameter cannot be adjusted while the motor is running.</p> <p>Enter the number of motor poles.</p> <table border="1"> <thead> <tr> <th>Poles</th> <th>~n_n@ 50 Hz</th> <th>~n_n@ 60 Hz</th> </tr> </thead> <tbody> <tr> <td>2</td> <td>2700–2880</td> <td>3250–3460</td> </tr> <tr> <td>4</td> <td>1350–1450</td> <td>1625–1730</td> </tr> <tr> <td>6</td> <td>700–960</td> <td>840–1153</td> </tr> </tbody> </table> <p>Table 3.5 Pole Counts and Related Frequencies</p> <p>Table 3.5 shows the pole numbers for normal speed ranges of various motor types. Define motors designed for other frequencies separately. The motor pole value is always an even number, because it refers to the total pole numbers, not pairs of poles. The frequency converter creates the initial setting of <i>parameter 1-39 Motor Poles</i> based on <i>parameter 1-23 Motor Frequency</i> and <i>parameter 1-25 Motor Nominal Speed</i>.</p>	Poles	~n _n @ 50 Hz	~n _n @ 60 Hz	2	2700–2880	3250–3460	4	1350–1450	1625–1730	6	700–960	840–1153
Poles	~n _n @ 50 Hz	~n _n @ 60 Hz												
2	2700–2880	3250–3460												
4	1350–1450	1625–1730												
6	700–960	840–1153												

1-40 Back EMF at 1000 RPM		
Range:		Function:
Size related*	[10 - 9000 V]	Set the nominal back EMF for the motor when running at 1000 RPM. This parameter is only active when <i>parameter 1-10 Motor Construction</i> is set to [1] PM, non salient SPM.

1-41 Motor Angle Offset		
Range:		Function:
0*	[-32768 - 32767]	Enter the correct offset angle between the PM motor and the index position (single-turn) of the attached encoder or resolver. The value range of 0–32768 corresponds to 0–2 x pi (radians). This parameter is only active when <i>parameter 1-10 Motor Construction</i> is set to [1] PM, non-salient SPM (Permanent Magnet Motor).

1-44 d-axis Inductance Sat. (LdSat)		
Range:		Function:
Size related*	[0 - 1000 mH]	Enter the inductance saturation of Ld. Ideally, this parameter has the same value as <i>parameter 1-37 d-axis Inductance (Ld)</i> . If the motor supplier provides an induction curve, enter the induction value at 200% of the nominal value.

1-45 q-axis Inductance Sat. (LqSat)		
Range:		Function:
Size related*	[0 - 1000 mH]	This parameter corresponds to the inductance saturation of Lq. Ideally, this parameter has the same value as <i>parameter 1-38 q-axis Inductance (Lq)</i> . If the motor supplier provides an induction curve, enter the induction value at 200% of the nominal value.

1-46 Position Detection Gain		
Range:		Function:
100 %*	[20 - 200 %]	Adjusts the amplitude of the test pulse during position detection at start. Adjust this parameter to improve the position measurement.

1-47 Torque Calibration		
Option:	Function:	
		Use this parameter to optimize the torque estimate in the full speed range. The estimated torque is based on the shaft power, $P_{\text{shaft}} = P_m - R_s \times I^2$. Make sure that the R_s value is correct. The R_s value in this formula is equal to the power loss in the motor, the cable, and the frequency converter. When this parameter is active, the frequency converter calculates the R_s value during power-up, ensuring the optimal torque estimate and optimal performance. Use this feature in cases when it is not possible to adjust <i>parameter 1-30 Stator Resistance (Rs)</i> on each frequency converter to compensate for the cable length, frequency converter losses, and the temperature deviation on the motor.
[0]	Off	
[1]	1st start after pwr-up	Calibrates at the first start-up after power-up and keeps this value until reset by a power cycle.
[2]	Every start	Calibrates at every start-up, compensating for a possible change in motor temperature since last start-up. The value is reset after a power cycle.
[3]	1st start with store	The frequency converter calibrates the torque at the first start-up after power-up. This option is used to update motor parameters: <ul style="list-style-type: none"> Parameter 1-30 Stator Resistance (Rs). Parameter 1-37 d-axis Inductance (Ld).
[4]	Every start with store	The frequency converter calibrates the torque at every start-up, compensating for a possible change in motor temperature since last start-up. This option is used to update motor parameters: <ul style="list-style-type: none"> Parameter 1-30 Stator Resistance (Rs). Parameter 1-37 d-axis Inductance (Ld).

1-48 Inductance Sat. Point		
Range:	Function:	
Size related*	[1 - 500 %]	Enter the induction saturation point.

3.3.7 1-5* Load Indep. Setting

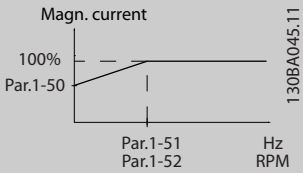
1-50 Motor Magnetisation at Zero Speed		
This parameter is not visible on the LCP.		
Range:	Function:	
100 % *	[0 - 300 %]	<p>NOTICE Parameter 1-50 Motor Magnetisation at Zero Speed has no effect when parameter 1-10 Motor Construction = [1] PM, non-salient SPM.</p> <p>Use this parameter along with parameter 1-51 Min Speed Normal Magnetising [RPM] to obtain a different thermal load on the motor when running at low speed. Enter a value which is a percentage of the rated magnetizing current. If the setting is too low, the torque on the motor shaft may be reduced.</p>  <p>Illustration 3.8 Motor Magnetization</p>

1-51 Min Speed Normal Magnetising [RPM]		
This parameter is not visible on the LCP.		
Range:	Function:	
Size related*	[10 - 300 RPM]	<p>NOTICE Parameter 1-51 Min Speed Normal Magnetising [RPM] has no effect when parameter 1-10 Motor Construction=[1] PM, non-salient SPM.</p> <p>Set the required speed for normal magnetizing current. If the speed is set lower than the motor slip speed, parameter 1-50 Motor Magnetisation at Zero Speed and parameter 1-51 Min Speed Normal Magnetising [RPM] are of no significance. Use this parameter along with parameter 1-50 Motor Magnetisation at Zero Speed. See Table 3.5.</p>

1-52 Min Speed Normal Magnetising [Hz]		
This parameter is not visible on the LCP.		
Range:	Function:	
Size related*	[0.3 - 10.0 Hz]	<p>NOTICE Parameter 1-52 Min Speed Normal Magnetising [Hz] has no effect when parameter 1-10 Motor Construction = [1] PM, non-salient SPM.</p> <p>Set the required frequency for normal magnetizing current. If the frequency is set lower than the motor slip frequency, parameter 1-50 Motor Magnetisation at Zero Speed and parameter 1-51 Min Speed Normal Magnetising [RPM] are inactive. Use this parameter along with parameter 1-50 Motor Magnetisation at Zero Speed. See Table 3.5.</p>

1-58 Flying Start Test Pulses Current		
Range:	Function:	
Size related*	[0 - 200 %]	<p>Set the magnitude of the magnetizing current for the pulses used to detect the motor direction. Higher values result in more accurate results when the frequency converter is oversized compared to the motor. The value range and function depend on parameter 1-10 Motor Construction: [0] Asynchron: [0-200%] Reducing this value reduces the generated torque. 100% means full nominal motor current. In this case, the default value is 30%. [1] PM non salient: [0-40%]. A general setting of 20% is recommended on PM motors. Higher values can give increased performance. However, on motors with back EMF higher than 300 VLL (rms) at nominal speed and high winding inductance (more than 10 mH) a lower value is recommended to avoid wrong speed estimation. The parameter is active when parameter 1-73 Flying Start is enabled.</p>

1-59 Flying Start Test Pulses Frequency		
Range:	Function:	
Size related*	[0 - 500 %]	<p>NOTICE See description of parameter 1-70 PM Start Mode for an overview of the relation between the PM Flying Start parameters.</p> <p>The parameter is active when parameter 1-73 Flying Start is enabled. The value range and function depend on parameter 1-10 Motor Construction:</p>

1-59 Flying Start Test Pulses Frequency	
Range:	Function:
	<p>[0] <i>Asynchron</i>: [0-500%] Control the percentage of the frequency for the pulses used to detect the motor direction. Increasing this value reduces the generated torque. In this mode, 100% means 2 times the slip frequency.</p> <p>[1] <i>PM non salient</i>: [0-10%] This parameter defines the motor speed (in % of nominal motor speed) below which the parking function (see <i>parameter 2-06 Parking Current</i> and <i>parameter 2-07 Parking Time</i> becomes active). This parameter is only active when <i>parameter 1-70 PM Start Mode</i> is set to [1] <i>Parking</i> and only after starting the motor.</p>

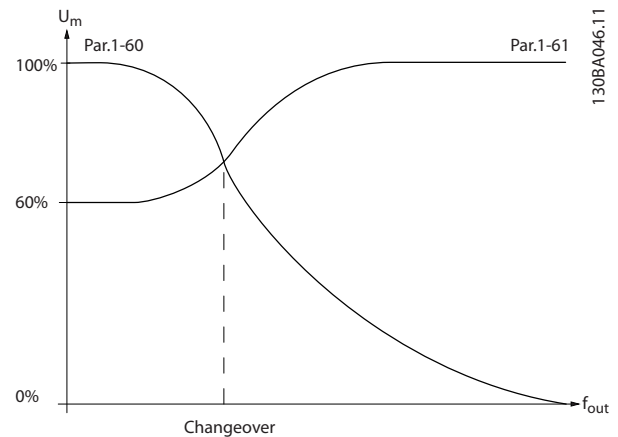

Illustration 3.9 Low Speed Load Compensation

3.3.8 1-6* Load Depend. Setting

1-60 Low Speed Load Compensation									
This parameter is not visible on the LCP.									
Range:	Function:								
100 %* [0 - 300 %]	<p>NOTICE <i>Parameter 1-60 Low Speed Load Compensation has no effect when parameter 1-10 Motor Construction = [1] PM, non-salient SPM.</i></p> <p>Enter the % value to compensate voltage in relation to load when the motor is running at low speed, and obtain the optimum U/f characteristic. The motor size determines the frequency range within which this parameter is active.</p> <table border="1"> <thead> <tr> <th>Motor size [kW]</th> <th>Change-over [Hz]</th> </tr> </thead> <tbody> <tr> <td>0.25-7.5</td> <td><10</td> </tr> <tr> <td>11-45</td> <td><5</td> </tr> <tr> <td>55-550</td> <td><3-4</td> </tr> </tbody> </table> <p>Table 3.6 Low Speed Load Compensation</p>	Motor size [kW]	Change-over [Hz]	0.25-7.5	<10	11-45	<5	55-550	<3-4
Motor size [kW]	Change-over [Hz]								
0.25-7.5	<10								
11-45	<5								
55-550	<3-4								

1-61 High Speed Load Compensation					
This parameter is not visible on the LCP.					
Range:	Function:				
100 %* [0 - 300 %]	<p>NOTICE <i>Parameter 1-61 High Speed Load Compensation has no effect when parameter 1-10 Motor Construction = [1] PM, non-salient SPM.</i></p> <p>Enter the % value to compensate voltage in relation to load when the motor is running at high speed, and obtain the optimum U/f characteristic. The motor size determines the frequency range within which this parameter is active.</p> <table border="1"> <thead> <tr> <th>Motor size</th> <th>Change-over</th> </tr> </thead> <tbody> <tr> <td>1.1-7.5 kW</td> <td>>10 Hz</td> </tr> </tbody> </table>	Motor size	Change-over	1.1-7.5 kW	>10 Hz
Motor size	Change-over				
1.1-7.5 kW	>10 Hz				

1-62 Slip Compensation	
Range:	Function:
0 %* [-500 - 500 %]	<p>NOTICE <i>Parameter 1-62 Slip Compensation has no effect when parameter 1-10 Motor Construction = [1] PM, non-salient SPM.</i></p> <p>Enter the % value for slip compensation to compensate for tolerances in the value of $n_{M,N}$. Slip compensation is calculated automatically, that is on the basis of the rated motor speed $n_{M,N}$.</p>

1-63 Slip Compensation Time Constant		
Range:		Function:
Size related*	[0.05 - 5 s]	<p>NOTICE Parameter 1-63 Slip Compensation Time Constant has no effect when parameter 1-10 Motor Construction = [1] PM, non-salient SPM.</p> <p>Enter the slip compensation reaction speed. A high value results in slow reaction, and a low value results in quick reaction. If low-frequency resonance problems arise, use a longer time setting.</p>

1-64 Resonance Dampening		
Range:		Function:
100 %*	[0 - 500 %]	<p>NOTICE Parameter 1-64 Resonance Dampening has no effect when parameter 1-10 Motor Construction=[1] PM, non-salient SPM.</p> <p>Enter the resonance damping value. Set parameter 1-64 Resonance Dampening and parameter 1-65 Resonance Dampening Time Constant to help eliminate high frequency resonance problems. To reduce resonance oscillation, increase the value of parameter 1-64 Resonance Dampening.</p>

1-65 Resonance Dampening Time Constant		
Range:		Function:
5 ms*	[5 - 50 ms]	<p>NOTICE Parameter 1-65 Resonance Dampening Time Constant has no effect when parameter 1-10 Motor Construction = [1] PM, non-salient SPM.</p> <p>Set parameter 1-64 Resonance Dampening and parameter 1-65 Resonance Dampening Time Constant to help eliminate high frequency resonance problems. Enter the time constant that provides the best dampening.</p>

1-66 Min. Current at Low Speed		
Range:		Function:
Size related*	[1 - 200 %]	<p>NOTICE Parameter 1-66 Min. Current at Low Speed has no effect if parameter 1-10 Motor Construction = [0] Asynchron.</p> <p>Enter the minimum motor current at low speed.</p>

1-66 Min. Current at Low Speed		
Range:		Function:
		Increasing this current improves developed motor torque at low speed. Low speed is here defined as speeds below 6% of the nominal motor speed (parameter 1-25 Motor Nominal Speed) in VVC+ PM Control.

3.3.9 1-7* Start Adjustments

1-70 PM Start Mode		
Option:		Function:
[0]	Rotor Detection	Suitable for all applications where the motor is known to be standing still when starting (for example conveyors, pumps, and non-wind milling fans).
[1] *	Parking	If the motor turns at a low speed (that is lower than 2–5% of the nominal speed), for example due to fans with windmilling, select [1] Parking and adjust parameter 2-06 Parking Current and parameter 2-07 Parking Time accordingly.

1-71 Start Delay		
Range:		Function:
00 s*	[0 - 300 s]	<p>Enter the time delay between the start command and the time when the frequency converter supplies power to the motor.</p> <p>This parameter is related to the start function selected in parameter 1-72 Start Function. The parameter is used for delayed start of compressor functionality in injection control. Parameter 28-91 Delayed Compressor Start controls the delayed start feature. Set the start delay value equal to or greater than the default value.</p>

1-72 Start Function		
Option:		Function:
		Select the start function during the start delay. This parameter is linked to parameter 1-71 Start Delay.
[0]	DC Hold/ Motor Preheat	Energizes motor with a DC holding current (parameter 2-00 DC Hold/Preheat Current) during the start delay time.
[1]	DC Brake	Energises motor with a DC braking current (parameter 2-01 DC Brake Current) during the start delay time.
[2]	Coast	Releases shaft coasted converter during the start delay time (inverter off). Available selections depend on parameter 1-10 Motor Construction: [0] Asynchron:

1-72 Start Function	
Option:	Function:
	[2] Coast [0] DC-hold [1] PM non-salient: [2] coast
[3] Start speed cw	
[5] VVC+/Flux clockwise	

1-73 Flying Start	
Option:	Function:
	This function enables catching a motor which is spinning freely due to a mains drop-out. When <i>parameter 1-73 Flying Start</i> is enabled, <i>parameter 1-71 Start Delay</i> has no function. Search direction for flying start is linked to the setting in <i>parameter 4-10 Motor Speed Direction</i> . [0] Clockwise: Flying start searches in clockwise direction. If not successful, a DC brake is activated. [2] Both Directions: The flying start first makes a search in the direction determined by the last reference (direction). If the speed is not found, it makes a search in the other direction. If not successful, a DC brake is activated in the time set in <i>parameter 2-02 DC Braking Time</i> . Start then takes place from 0 Hz.
[0] Disabled	Select [0] Disable if this function is not required.
[1] Enabled	Select [1] Enable to enable the frequency converter to catch and control a spinning motor. The parameter is always set to [1] Enable when <i>parameter 1-10 Motor Construction</i> =[1] PM non-salient. Important related parameters: <ul style="list-style-type: none"> Parameter 1-58 Flying Start Test Pulses Current Parameter 1-59 Flying Start Test Pulses Frequency Parameter 1-70 PM Start Mode Parameter 2-06 Parking Current Parameter 2-07 Parking Time Parameter 2-03 DC Brake Cut In Speed [RPM] Parameter 2-04 DC Brake Cut In Speed [Hz] Parameter 2-06 Parking Current Parameter 2-07 Parking Time
[2] Enabled Always	
[3] Enabled Ref. Dir.	

1-73 Flying Start	
Option:	Function:
[4] Enab. Always Ref. Dir.	

The flying-start function used for PM motors is based on an initial speed estimation. The speed is always estimated as the first thing after an active start signal is given. Based on the setting of *parameter 1-70 PM Start Mode* the following happens:

Parameter 1-70 PM Start Mode=[0] Rotor Detection:

If the speed estimate appears as greater than 0 Hz, the frequency converter catches the motor at that speed and resumes normal operation. Otherwise, the frequency converter estimates the rotor position and start normal operation from there.

Parameter 1-70 PM Start Mode=[1] Parking:

A speed estimate lower than the setting in *parameter 1-59 Flying Start Test Pulses Frequency* engages the parking function (see *parameter 2-06 Parking Current* and *parameter 2-07 Parking Time*). Otherwise, the frequency converter catches the motor at that speed and resumes normal operation. Refer to the description of *parameter 1-70 PM Start Mode* for recommended settings.

Current limitations of the flying-start principle used for PM motors:

- The speed range is up to 100% nominal speed or the field weakening speed (whichever is lowest).
- PMSM with high back EMF (>300 VLL(rms)) and high winding inductance (>10 mH) needs more time for reducing short-circuit current to 0 and may be susceptible to error in estimation.
- Current testing limited to a speed range up to 300 Hz. For certain units, the limit is 250 Hz; all 200–240 V units up to and including 2.2 kW (3 hp) and all 380–480 V units up to and including 4 kW (5 hp).
- For high-inertia applications (that is, where the load inertia is more than 30 times larger than the motor inertia), use a brake resistor to avoid overvoltage trip during high-speed engagement of the flying-start function.

1-74 Start Speed [RPM]	
Range:	Function:
Size related* [0 - 600 RPM]	Set a motor start speed. After the start signal, the output speed leaps to set value. Set the start function in <i>parameter 1-72 Start Function</i> to [3] Start speed cw, [4] Horizontal operation, or [5] VVC +/Flux clockwise, and set a start delay time in <i>parameter 1-71 Start Delay</i> .

1-75 Start Speed [Hz]		
Range:		Function:
Size related*	[0 - 500.0 Hz]	This parameter can be used for hoist applications (cone rotor). Set a motor start speed. After the start signal, the output speed leaps to the set value. Set the start function in <i>parameter 1-72 Start Function</i> to [3] <i>Start speed cw</i> , [4] <i>Horizontal operation</i> , or [5] <i>VVC*/Flux clockwise</i> , and set a start delay time in <i>parameter 1-71 Start Delay</i> .

1-76 Start Current		
Range:		Function:
0 A*	[0 - 1-24 A]	Some motors, for example cone rotor motors, need extra current/starting speed to disengage the rotor. To obtain this boost, set the required current in <i>parameter 1-76 Start Current</i> . Set <i>parameter 1-74 Start Speed [RPM]</i> . Set <i>parameter 1-72 Start Function</i> to [3] <i>Start speed cw</i> or [4] <i>Horizontal operation</i> , and set a start delay time in <i>parameter 1-71 Start Delay</i> . This parameter can be used for hoist applications (cone rotor).

1-77 Compressor Start Max Speed [RPM]		
Range:		Function:
Size related*	[0 - 4-13 RPM]	<p>NOTICE <i>Parameter 1-77 Compressor Start Max Speed [RPM] has no effect when parameter 1-10 Motor Construction = [1] PM, non-salient SPM.</i></p> <p>The parameter enables high starting torque. This is a function, where the current limit and torque limit are ignored during start of the motor. The time from the start signal is given until the speed exceeds the speed set in this parameter, becomes a start-zone where the current limit and motoric torque limit is set to what is maximum possible for the frequency converter/motor combination. This parameter is normally set to the same value as <i>parameter 4-11 Motor Speed Low Limit [RPM]</i>. When set to 0, the function is inactive. In this starting-zone, <i>parameter 3-82 Starting Ramp Up Time</i> is active to ensure extra acceleration during the start and to minimize the time where the motor is operated under the minimum speed for the application. The time without protection from the current limit and torque limit must not exceed the value set in <i>parameter 1-79 Compressor Start Max Time to Trip</i>. If the value in <i>parameter 1-79 Compressor Start Max Time to</i></p>

1-77 Compressor Start Max Speed [RPM]		
Range:		Function:
		<p><i>Trip</i> is exceeded, the frequency converter trips with <i>alarm 18, Start failed</i>.</p> <p>When this function is activated to get a fast start, <i>parameter 1-86 Compressor Min. Speed for Trip [RPM]</i> is also activated to protect the application from running below minimum motor speed, for example when in current limit.</p> <p>This function allows high starting torque and use of a fast starting ramp. To ensure the build-up of a high torque during the start, enter appropriate values for start delay/start speed/start current.</p>

1-78 Compressor Start Max Speed [Hz]		
Range:		Function:
Size related*	[0 - 4-14 Hz]	<p>NOTICE <i>Parameter 1-78 Compressor Start Max Speed [Hz] has no effect when parameter 1-10 Motor Construction = [1] PM, non-salient SPM.</i></p> <p>The parameter enables high starting torque. This is a function, where the current limit and torque limit are ignored during start of the motor. The time, from the start signal is given until the speed exceeds the speed set in this parameter, becomes a start-zone where the current limit and motoric torque limit is set to what is maximum possible for the frequency converter/motor combination. This parameter is normally set to the same value as <i>parameter 4-11 Motor Speed Low Limit [RPM]</i>. When set to 0, the function is inactive. In this starting-zone, <i>parameter 3-82 Starting Ramp Up Time</i> is active instead of <i>parameter 3-41 Ramp 1 Ramp Up Time</i> to ensure extra acceleration during the start, and to minimize the time where the motor is operated under the minimum speed for the application. The time without protection from the current limit and torque limit must not exceed the value set in <i>parameter 1-79 Compressor Start Max Time to Trip</i>. If the value of <i>parameter 1-79 Compressor Start Max Time to Trip</i> is exceeded, the frequency converter trips with <i>alarm 18, Start failed</i>.</p> <p>When this function is activated to get a fast start, <i>parameter 1-86 Compressor Min. Speed for Trip [RPM]</i> is also activated to protect the application from running below minimum motor speed, for example when in current limit.</p>

1-78 Compressor Start Max Speed [Hz]		
Range:	Function:	
	This function allows high starting torque and use of a fast starting ramp. To ensure the build-up of a high torque during the start, enter appropriate values for start delay/start speed/start current.	

1-79 Compressor Start Max Time to Trip		
Range:	Function:	
5 s* [0 - 10 s]	<p>NOTICE Parameter 1-79 Compressor Start Max Time to Trip has no effect when parameter 1-10 Motor Construction = [1] PM, non-salient SPM.</p> <p>The time from the start signal is given until the speed exceeds the speed set in parameter 1-77 Compressor Start Max Speed [RPM] must not exceed the time set in the parameter. If the time set is exceeded, the frequency converter trips with alarm 18, Start failed.</p> <p>Any time set in parameter 1-71 Start Delay for use of a start function must be executed within the time limit.</p>	

3.3.10 1-8* Stop Adjustments

1-80 Function at Stop		
Option:	Function:	
	Select the frequency converter function after a stop command or after the speed is ramped down to the settings in parameter 1-81 Min Speed for Function at Stop [RPM]. Available selections depend on parameter 1-10 Motor Construction: [0] Asynchronous: [0] Coast [1] DC hold [2] Motor check, warning [6] Motor check, alarm [1] PM non-salient: [0] Coast	
[0] *	Coast	Leaves motor in free mode.
[1]	DC Hold/ Motor Preheat	Energizes motor with a DC hold current (see parameter 2-00 DC Hold/Preheat Current).

1-81 Min Speed for Function at Stop [RPM]		
Range:	Function:	
Size related* [0 - 600 RPM]	Set the speed at which to activate parameter 1-80 Function at Stop.	

1-82 Min Speed for Function at Stop [Hz]		
Range:	Function:	
Size related* [0 - 20.0 Hz]	Set the output frequency at which to activate parameter 1-80 Function at Stop.	

1-86 Compressor Min. Speed for Trip [RPM]		
Range:	Function:	
Size related* [0 - 1500 RPM]	<p>NOTICE This parameter is only available if parameter 0-02 Motor Speed Unit is set to [11] RPM.</p> <p>Enter the low limit for the motor speed at which the frequency converter trips. If the value is 0, the function is not active. If the speed at any time after the start (or during a stop) drops below the value in the parameter, the frequency converter trips with alarm 49, Speed Limit.</p>	

1-87 Compressor Min. Speed for Trip [Hz]		
Range:	Function:	
Size related* [0 - 50 Hz]	<p>NOTICE This parameter is only available if parameter 0-02 Motor Speed Unit is set to [1] Hz.</p> <p>Enter the low limit for the motor speed at which the frequency converter trips. If the value is 0, the function is not active. If the speed at any time after the start (or during a stop) drops below the value in the parameter, the frequency converter trips with alarm 49, Speed Limit.</p>	

3.3.11 1-9* Motor Temperature

NOTICE

When using multiple motors, the electronic thermal relay on the frequency converter cannot be used to provide individual motor protection. Supply a separate motor overload for each motor.

1-90 Motor Thermal Protection		
Option:	Function:	
	The frequency converter determines the motor temperature for motor overload protection in 2 different ways: <ul style="list-style-type: none"> Via a thermistor sensor connected to 1 of the analog or digital inputs (parameter 1-93 Thermistor Source). 	

1-90 Motor Thermal Protection		
Option:	Function:	
		<p>See <i>chapter 3.3.12.1 PTC Thermistor Connection</i>.</p> <ul style="list-style-type: none"> Via calculation (ETR=electronic thermal relay) of the thermal load, based on the actual load and time. The calculated thermal load is compared with the rated motor current $I_{M,N}$ and the rated motor frequency $f_{M,N}$. The calculations estimate the need for a lower load at lower speed due to less cooling from the fan incorporated in the motor. See <i>chapter 3.3.12.2 ETR</i>. Via a mechanical thermal switch (Klixon type). See <i>chapter 3.3.12.3 Klixon</i>. The ETR provides class 20 motor overload protection in accordance with NEC.
[0]	No protection	If the motor is continuously overloaded, and no warning or trip of frequency converter is wanted.
[1]	Thermistor warning	Activates a warning when the connected thermistor in the motor reacts in the event of motor overtemperature.
[2]	Thermistor trip	Stops (trips) the frequency converter when the connected thermistor in the motor reacts in the event of motor overtemperature.
[3]	ETR warning 1	
[4]	ETR trip 1	
[5]	ETR warning 2	
[6]	ETR trip 2	
[7]	ETR warning 3	
[8]	ETR trip 3	
[9]	ETR warning 4	
[10]	ETR trip 4	

ETR functions 1-4 calculate the load when the set-up where they were selected is active. For example ETR-3 starts calculating when set-up 3 is selected. For the North American market: The ETR functions provide class 20 motor overload protection in accordance with NEC.

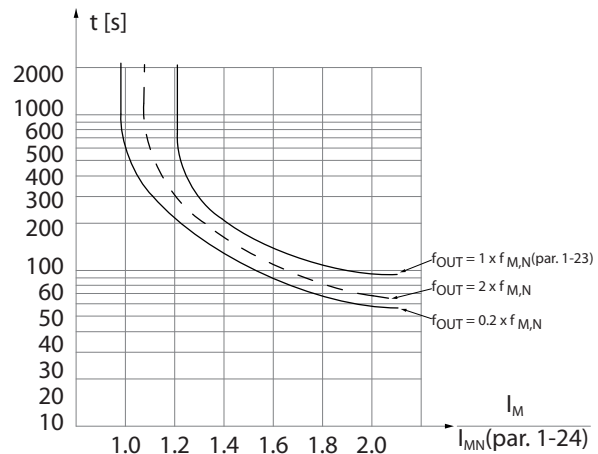

Illustration 3.10 Thermal Motor Protection

NOTICE

If the temperature of the motor is monitored through a thermistor or a KTY Sensor, the PELV is not complied with in case of short circuits between motor windings and the sensor. To comply with PELV, isolate the sensor appropriately.

NOTICE

Danfoss recommends using 24 V DC as thermistor supply voltage.

NOTICE

The ETR timer function does not work when *parameter 1-10 Motor Construction=[1] PM, non-salient SPM*.

NOTICE

For correct operation of the ETR function, the setting in *parameter 1-03 Torque Characteristics* must fit the application (see description of *parameter 1-03 Torque Characteristics*).

3.3.12.1 PTC Thermistor Connection

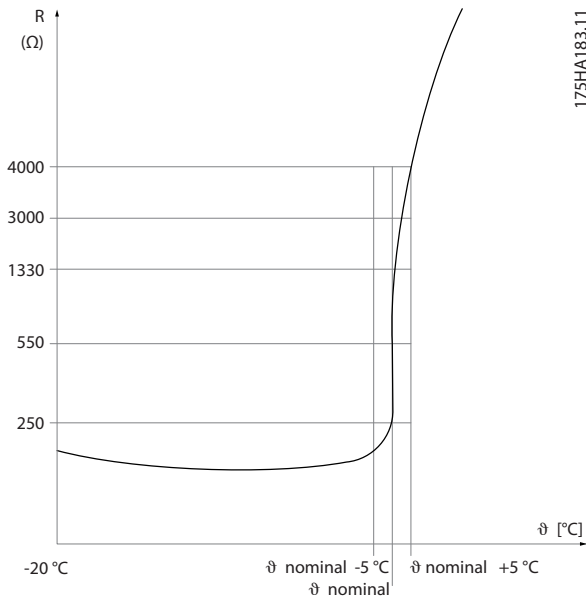

Illustration 3.11 PTC Profile

Example using a digital input and 10 V as supply

The frequency converter trips when the motor temperature is too high.

Parameter set-up:

- Set parameter 1-90 Motor Thermal Protection to [2] Thermistor Trip.
- Set parameter 1-93 Thermistor Source to [6] Digital Input.

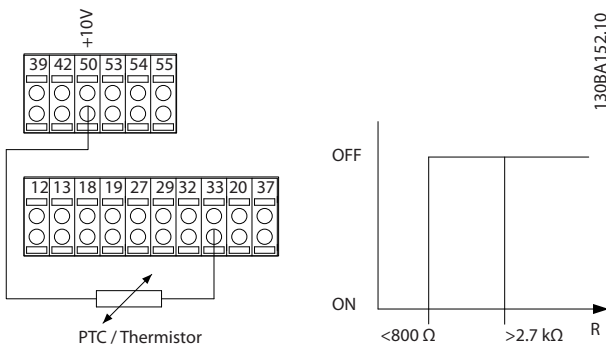

Illustration 3.12 PTC Thermistor Connection - Digital Input

Example using an analog input and 10 V as supply

The frequency converter trips when the motor temperature is too high.

Parameter set-up:

- Set parameter 1-90 Motor Thermal Protection to [2] Thermistor Trip.
- Set parameter 1-93 Thermistor Source to [2] Analog Input 54.

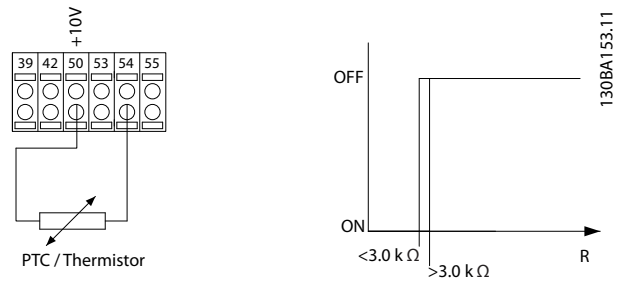

Illustration 3.13 PTC Thermistor Connection - Analog Input

Input digital/analog	Supply voltage [V]	Threshold cutout values.
Digital	10	<800 Ω⇒2.7 kΩ
Analog	10	<3.0 kΩ⇒3.0 kΩ

Table 3.7 Threshold Cutout Values

NOTICE

Check that the selected supply voltage follows the specification of the used thermistor element.

3.3.12.2 ETR

The calculations estimate the need for a lower load at lower speed due to less cooling from the fan incorporated in the motor.

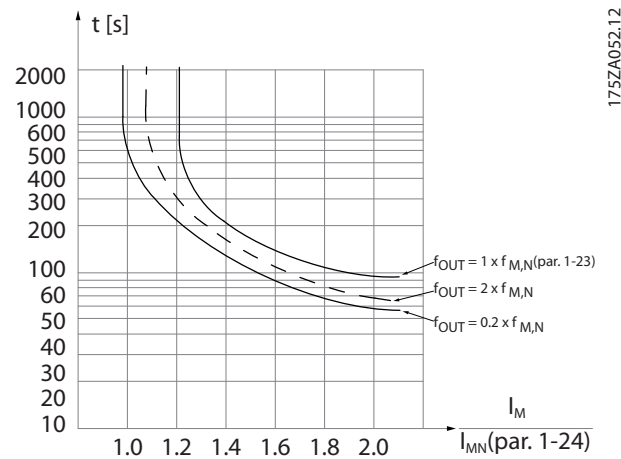

Illustration 3.14 ETR Profile

3.3.12.3 Klixon

The Klixon type thermal circuit breaker uses a KLIXON® metal dish. At a predetermined overload, the heat caused by the current through the disc causes a trip.

Example using a digital input and 24 V as supply

The frequency converter trips when the motor temperature is too high.

Parameter set-up:

- Set parameter 1-90 Motor Thermal Protection to [2] Thermistor Trip.
- Set parameter 1-93 Thermistor Source to [6] Digital Input.

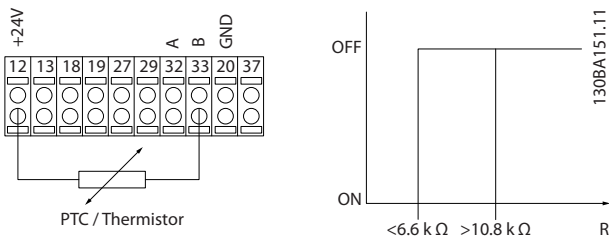

Illustration 3.15 Thermistor Connection

1-93 Thermistor Source	
Option:	Function:
[0] *	None <i>parameter 3-16 Reference 2 Source, or parameter 3-17 Reference 3 Source).</i> When using VLT® PTC Thermistor Card MCB 112, always select [0] None.
[1]	Analog Input 53
[2]	Analog Input 54
[3]	Digital input 18
[4]	Digital input 19
[5]	Digital input 32
[6]	Digital input 33

1-91 Motor External Fan	
Option:	Function:
[0] *	No No external fan is required, that is the motor is derated at low speed.
[1]	Yes Applies an external motor fan (external ventilation), so no derating of the motor is required at low speed. The upper curve in <i>Illustration 3.14</i> ($f_{out} = 1 \times f_{M,N}$) is followed if the motor current is lower than nominal motor current (see <i>parameter 1-24 Motor Current</i>). If the motor current exceeds nominal current, the operation time still decreases as if no fan was installed.

1-93 Thermistor Source	
Option:	Function:
	<p>NOTICE This parameter cannot be adjusted while the motor is running.</p> <p>NOTICE Set digital input to [0] PNP - Active at 24 V in <i>parameter 5-00 Digital I/O Mode</i>.</p> <p>Select the input to which the thermistor (PTC sensor) should be connected. An analog input option [1] <i>Analog Input 53</i> or [2] <i>Analog Input 54</i> cannot be selected if the analog input is already in use as a reference source (selected in <i>parameter 3-15 Reference 1 Source</i>,</p>

3.4 Parameters: 2-*** Brakes

3.4.1 2-0* DC brakes

Parameter group for configuring the DC brake and DC hold functions.

2-00 DC Hold/Preheat Current	
Range:	Function:
50 %* [0 - 160 %]	<p>NOTICE Parameter 2-00 DC Hold/Preheat Current has no effect when parameter 1-10 Motor Construction=[1] PM, non-salient SPM.</p> <p>NOTICE The maximum value depends on the rated motor current. Avoid 100% current for too long. It may damage the motor.</p> <p>Enter a value for holding current as a percentage of the rated motor current $I_{M,N}$ set in parameter 1-24 Motor Current. 100% DC hold current corresponds to $I_{M,N}$.</p> <p>This parameter holds the motor (holding torque) or preheats the motor.</p> <p>This parameter is active if [1] DC hold/Motor Preheat is selected in parameter 1-80 Function at Stop.</p>

2-01 DC Brake Current	
Range:	Function:
50 %* [0 - 1000 %]	<p>NOTICE The maximum value depends on the rated motor current. Avoid 100% current for too long. It may damage the motor.</p> <p>Enter a value for current as a percentage of the rated motor current $I_{M,N}$, see parameter 1-24 Motor Current. 100% DC brake current corresponds to $I_{M,N}$.</p> <p>DC brake current is applied on a stop command, when the speed is lower than the limit set in:</p> <ul style="list-style-type: none"> Parameter 2-03 DC Brake Cut In Speed [RPM]. Parameter 2-04 DC Brake Cut In Speed [Hz], when the DC brake inverse function is active, or via the serial communication port. <p>The braking current is active during the time period set in parameter 2-02 DC Braking Time.</p>

2-02 DC Braking Time	
Range:	Function:
10 s* [0 - 60 s]	Set the duration of the DC brake current set in parameter 2-01 DC Brake Current, once activated.

2-03 DC Brake Cut In Speed [RPM]	
Range:	Function:
Size related* [0 - 0 RPM]	<p>Set the DC brake cut-in speed for activation of the DC braking current set in parameter 2-01 DC Brake Current, upon a stop command.</p> <p>When parameter 1-10 Motor Construction is set to [1] PM non-salient SPM, this value is limited to 0 RPM (OFF).</p>

2-04 DC Brake Cut In Speed [Hz]	
Range:	Function:
Size related* [0 - 0.0 Hz]	<p>NOTICE Parameter 2-04 DC Brake Cut In Speed [Hz] is not effective when parameter 1-10 Motor Construction = [1] PM, non-salient SPM.</p> <p>Set the DC brake cut-in speed for activation of the DC brake current set in parameter 2-01 DC Brake Current after a stop command.</p>

2-06 Parking Current	
Range:	Function:
50 %* [0 - 1000 %]	<p>NOTICE Parameter 2-06 Parking Current and parameter 2-07 Parking Time: Only active if [1] PM, non salient SPM is selected in parameter 1-10 Motor Construction.</p> <p>Set current as percentage of rated motor current, parameter 1-24 Motor Current. Active in connection with parameter 1-73 Flying Start. The parking current is active during the time period set in parameter 2-07 Parking Time.</p>

2-07 Parking Time	
Range:	Function:
3 s* [0.1 - 60 s]	<p>Set the duration of the parking current time set in parameter 2-06 Parking Current. Active in connection with parameter 1-73 Flying Start.</p> <p>NOTICE Parameter 2-07 Parking Time is only active when [1] PM, non-salient SPM is selected in parameter 1-10 Motor Construction.</p>

3.4.2 2-1* Brake Energy Funct.

Parameter group for selecting dynamic brake parameters.
Only valid for frequency converters with brake chopper.

3

2-10 Brake Function		
Option:	Function:	
		Available options depend on <i>parameter 1-10 Motor Construction</i> : <i>[0] Asynchron:</i> <ul style="list-style-type: none"> • [0] Off • [1] Resistor brake • [2] AC brake <i>[1] PM non-salient:</i> <ul style="list-style-type: none"> • [0] Off • [1] Resistor brake
[0]	Off	No brake resistor installed.
[1]	Resistor brake	Brake resistor incorporated in the system for dissipation of excess brake energy as heat. Connecting a brake resistor allows a higher DC-link voltage during braking (generating operation). The resistor brake function is only active in frequency converters with an integral dynamic brake.
[2]	AC brake	AC brake only works in compressor torque mode in <i>parameter 1-03 Torque Characteristics</i> .

2-16 AC brake Max. Current		
Range:	Function:	
100 %* [0 - 1000.0 %]	NOTICE Parameter 2-16 AC brake Max. Current has no effect when parameter 1-10 Motor Construction = [1] PM, non-salient SPM. Enter the maximum permissible current when using AC brake to avoid overheating of motor windings.	

2-17 Over-voltage Control		
Overvoltage control (OVC) reduces the risk of the frequency converter tripping due to an overvoltage on the DC link caused by generative power from the load.		
Option:	Function:	
	NOTICE The ramp time is automatically adjusted to avoid tripping of the frequency converter.	
[0]	Disabled	No OVC required.
[2] *	Enabled	Activates OVC.

3.5 Parameters: 3-** Reference/Ramps

3.5.1 3-0* Reference Limits

3-02 Minimum Reference		
Range:		Function:
Size related*	[-999999.999 - par. 3-03 ReferenceFeed-backUnit]	Enter the minimum reference. The minimum reference is the lowest value obtainable by summing all references. The minimum reference value and unit match the configuration made in <i>parameter 1-00 Configuration Mode</i> and <i>parameter 20-12 Reference/Feedback Unit</i> .
<p>NOTICE This parameter is used in open loop only.</p>		

3-03 Maximum Reference		
Range:		Function:
Size related*	[par. 3-02 - 999999.999 ReferenceFeed-backUnit]	Enter the maximum reference. The maximum reference is the highest value obtainable by summing all references.
<p>The maximum reference unit matches the configuration selected in <i>parameter 1-00 Configuration Mode</i>: For [1] <i>Speed closed loop</i>, RPM; for [2] <i>Torque</i>, Nm.</p> <p>If [9] <i>Positioning</i> is selected in <i>parameter 1-00 Configuration Mode</i>, this parameter defines the default speed for positioning.</p>		

3-04 Reference Function		
Option:	Function:	
[0] *	Sum	Sums both external and preset reference sources.
[1]	External/ Preset	Use either the preset or the external reference source. Shift between external and preset via a command or a digital input.

3

3.5.2 3-1* References

Select the preset reference(s). Select *Preset ref. bit 0/1/2 [16], [17], or [18]* for the corresponding digital inputs in *parameter group 5-1* Digital Inputs*.

3-10 Preset Reference		
Array [8]		
Range:		Function:
0 %*	[-100 - 100 %]	Enter up to 8 different preset references (0-7) in this parameter, using array programming. The preset reference is stated as a percentage of the value Ref _{MAX} (<i>parameter 3-03 Maximum Reference</i>). When using preset references, select preset reference bit 0/1/2 [16], [17], or [18] for the corresponding digital inputs in <i>parameter group 5-1* Digital Inputs</i> .

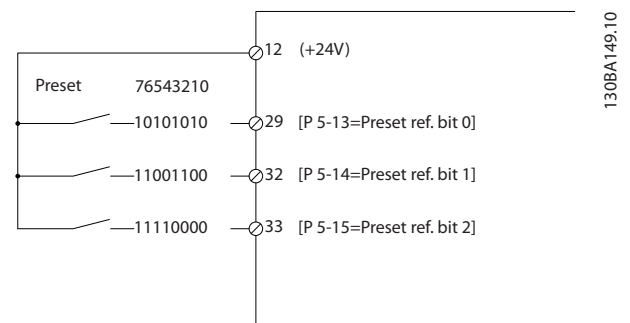
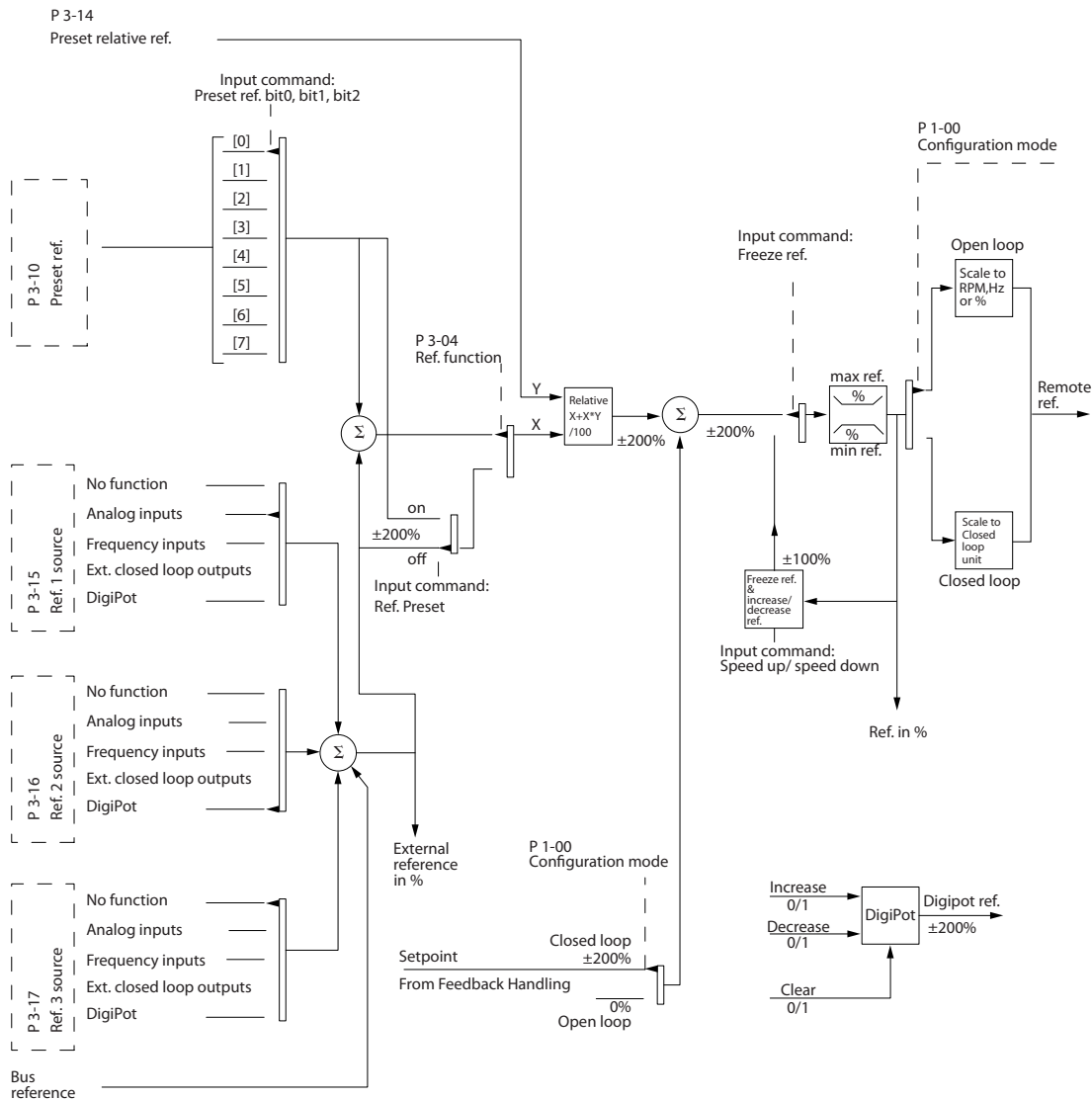

Illustration 3.16 Preset Reference Scheme



130BA357.12

Illustration 3.17 Example of Open-loop Operation and Closed-loop Operation

3-11 Jog Speed [Hz]		
Range:	Function:	
Size related*	[0 - par. 4-14 Hz]	The jog speed is a fixed output speed at which the frequency converter is running when the jog function is activated. See also <i>parameter 3-19 Jog Speed [RPM]</i> and <i>parameter 3-80 Jog Ramp Time</i> .

3-13 Reference Site		
Option:	Function:	
		Select which reference site to activate.
[0] *	Linked to Hand / Auto	Use local reference when in hand-on mode, or remote reference when in auto-on mode.
[1]	Remote	Use remote reference in both hand-on mode and auto-on mode.
[2]	Local	Use local reference in both hand-on mode and auto-on mode. NOTICE When set to [2] Local, the frequency converter starts with this setting again after a power-down.
[3]	Linked to H/A MCO	For information, see <i>VLT® Motion Control MCO 305 Operating Instructions</i> .

3-14 Preset Relative Reference		
Range:	Function:	
0 % * [-100 - 100 %]	<p>The actual reference, X, is increased or decreased with the percentage Y, set in <i>parameter 3-14 Preset Relative Reference</i>.</p> <p>This results in the actual reference Z. Actual reference (X) is the sum of the inputs selected in:</p> <ul style="list-style-type: none"> Parameter 3-15 Reference 1 Source. Parameter 3-16 Reference 2 Source. Parameter 3-17 Reference 3 Source. Parameter 8-02 Control Source. 	

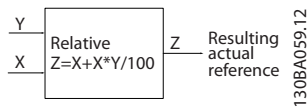

Illustration 3.18 Preset Relative Reference

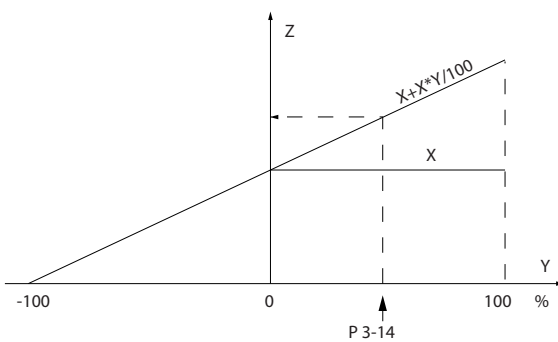

Illustration 3.19 Actual Reference

3-15 Reference 1 Source		
Option:	Function:	
	<p>NOTICE</p> <p>This parameter cannot be adjusted while the motor is running.</p> <p>Select the reference input to be used for the 1st reference signal:</p> <ul style="list-style-type: none"> Parameter 3-15 Reference 1 Source. Parameter 3-16 Reference 2 Source. Parameter 3-17 Reference 3 Source. <p>Define up to 3 different reference signals. The sum of these reference signals defines the actual reference.</p>	
[0]	No function	
[1] *	Analog Input 53	
[2]	Analog Input 54	

3-15 Reference 1 Source		
Option:	Function:	
[7]	Pulse input 29	
[8]	Pulse input 33	
[20]	Digital pot.meter	
[21]	Analog input X30/11	
[22]	Analog input X30/12	
[23]	Analog Input X42/1	
[24]	Analog Input X42/3	
[25]	Analog Input X42/5	
[30]	Ext. Closed Loop 1	
[31]	Ext. Closed Loop 2	
[32]	Ext. Closed Loop 3	

3-16 Reference 2 Source		
Option:	Function:	
	<p>NOTICE</p> <p>This parameter cannot be adjusted while the motor is running.</p> <p>Select the reference input to be used for the 2nd reference signal:</p> <ul style="list-style-type: none"> Parameter 3-15 Reference 1 Source. Parameter 3-16 Reference 2 Source. Parameter 3-17 Reference 3 Source. <p>Define up to 3 different reference signals. The sum of these reference signals defines the actual reference.</p>	
[0]	No function	
[1]	Analog Input 53	
[2]	Analog Input 54	
[7]	Pulse input 29	
[8]	Pulse input 33	
[20] *	Digital pot.meter	
[21]	Analog input X30/11	
[22]	Analog input X30/12	
[23]	Analog Input X42/1	
[24]	Analog Input X42/3	

3-16 Reference 2 Source		
Option:	Function:	
[25]	Analog Input X42/5	
[30]	Ext. Closed Loop 1	
[31]	Ext. Closed Loop 2	
[32]	Ext. Closed Loop 3	

3-17 Reference 3 Source		
Option:	Function:	
		<p>NOTICE</p> <p>This parameter cannot be adjusted while the motor is running.</p> <p>Select the reference input to be used for the 3rd reference signal:</p> <ul style="list-style-type: none"> Parameter 3-15 Reference 1 Source. Parameter 3-16 Reference 2 Source. Parameter 3-17 Reference 3 Source. <p>Define up to 3 different reference signals. The sum of these reference signals defines the actual reference.</p>
[0] *	No function	
[1]	Analog Input 53	
[2]	Analog Input 54	
[7]	Pulse input 29	
[8]	Pulse input 33	
[20]	Digital pot.meter	
[21]	Analog input X30/11	
[22]	Analog input X30/12	
[23]	Analog Input X42/1	
[24]	Analog Input X42/3	
[25]	Analog Input X42/5	
[30]	Ext. Closed Loop 1	
[31]	Ext. Closed Loop 2	
[32]	Ext. Closed Loop 3	

3-19 Jog Speed [RPM]		
Range:	Function:	
Size related*	[0 - par. 4-13 RPM]	<p>Enter a value for the jog speed n_{JOG}, which is a fixed output speed. The frequency converter runs at this speed when the jog function is activated. The maximum limit is defined in <i>parameter 4-13 Motor Speed High Limit [RPM]</i>.</p> <p>See also <i>parameter 3-11 Jog Speed [Hz]</i> and <i>parameter 3-80 Jog Ramp Time</i>.</p>

3.5.3 3-4* Ramp 1

Configure the ramp times for each of the 2 ramps (*parameter group 3-4* Ramp 1* and *parameter group 3-5* Ramp 2*).

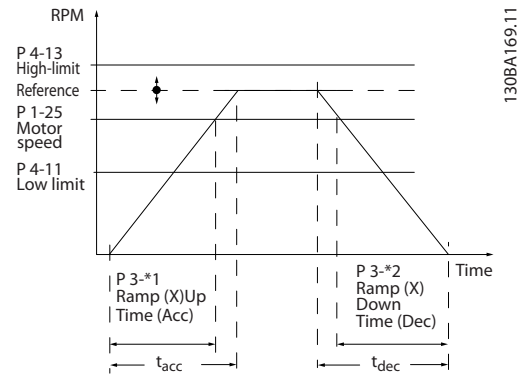

Illustration 3.20 Ramp 1

3-41 Ramp 1 Ramp Up Time		
Range:	Function:	
Size related*	[1.00 - 3600 s]	<p>Enter the ramp-up time, that is the acceleration time from 0 RPM– <i>parameter 1-25 Motor Nominal Speed</i>. Select a ramp-up time such that the output current does not exceed the current limit in <i>parameter 4-18 Current Limit</i> during ramping. See ramp-down time in <i>parameter 3-42 Ramp 1 Ramp Down Time</i>.</p> $par. 3 - 41 = \frac{t_{acc} \times n_{nom} [par. 1 - 25]}{ref [RPM]} [s]$

3-42 Ramp 1 Ramp Down Time		
Range:		Function:
Size related*	[1.00 - 3600 s]	Enter the ramp-down time, that is the deceleration time from <i>parameter 1-25 Motor Nominal Speed</i> –0 RPM. Select a ramp-down time preventing overvoltage from arising in the inverter due to regenerative operation of the motor. The ramp-down time should also be long enough to prevent that the generated current exceeds the current limit set in <i>parameter 4-18 Current Limit</i> . See ramp-up time in <i>parameter 3-41 Ramp 1 Ramp Up Time</i> .
$par. 3 - 42 = \frac{t_{dec} \times n_{nom} [par. 1 - 25]}{ref [RPM]} [s]$		

3.5.4 3-5* Ramp 2

To select ramp parameters, see *parameter group 3-4* Ramp 1*.

3-51 Ramp 2 Ramp Up Time		
Range:		Function:
Size related*	[1.00 - 3600 s]	Enter the ramp-up time, that is the acceleration time from 0 RPM– <i>parameter 1-25 Motor Nominal Speed</i> . Select a ramp-up time such that the output current does not exceed the current limit in <i>parameter 4-18 Current Limit</i> during ramping. See ramp-down time in <i>parameter 3-52 Ramp 2 Ramp Down Time</i> .
$par. 3 - 51 = \frac{t_{acc} \times n_{nom} [par. 1 - 25]}{ref [rpm]} [s]$		

3-52 Ramp 2 Ramp Down Time		
Range:		Function:
Size related*	[1.00 - 3600 s]	Enter the ramp-down time, that is the deceleration time from <i>parameter 1-25 Motor Nominal Speed</i> –0 RPM. Select a ramp-down time such that no overvoltage occurs in the inverter due to regenerative operation of the motor, and such that the generated current does not exceed the current limit set in <i>parameter 4-18 Current Limit</i> . See ramp-up time in <i>parameter 3-51 Ramp 2 Ramp Up Time</i> .
$par. 3 - 52 = \frac{t_{dec} \times n_{nom} [par. 1 - 25]}{ref [rpm]} [s]$		

3.5.5 3-8* Other Ramps

Parameters for configuring special ramps.

3-80 Jog Ramp Time		
Range:		Function:
Size related*	[1 - 3600 s]	Enter the jog ramp time, that is the acceleration/deceleration time between 0 RPM and the nominal motor speed ($n_{M,N}$) (set in <i>parameter 1-25 Motor Nominal Speed</i>). Ensure that the resulting output current required for the given jog ramp time does not exceed the current limit in <i>parameter 4-18 Current Limit</i> . The jog ramp time starts after activating a jog signal via the control panel, a selected digital input, or the serial communication port.
$par. 3 - 80 = \frac{t_{jog} \times n_{nom} [par. 1 - 25]}{jog\ speed [par. 3 - 19]} [s]$		

3

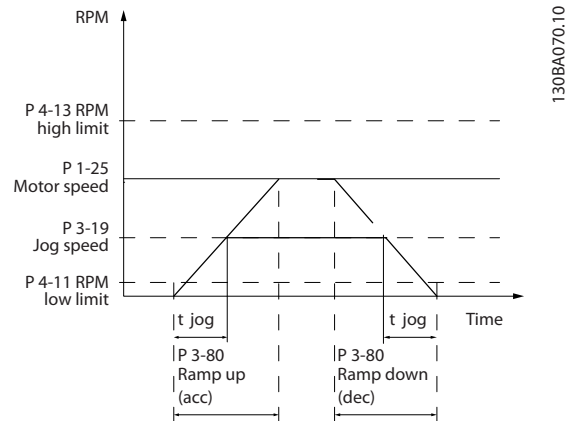

Illustration 3.21 Jog Ramp Time

3-81 Quick Stop Ramp Time		
Range:		Function:
Size related*	[1 - 3600 s]	Enter the quick stop ramp time. This is the acceleration/ deceleration time between 0 RPM and the rated motor frequency in <i>parameter 1-25 Motor Nominal Speed</i> . During ramping, the output current must not exceed the current limit in <i>parameter 4-18 Current Limit</i> .

3-82 Starting Ramp Up Time		
Range:		Function:
Size related*	[0.01 - 3600 s]	The ramp-up time is the acceleration time from 0 RPM to the nominal motor speed set in <i>parameter 3-82 Starting Ramp Up Time</i> when [0] Compressor Torque is active in <i>parameter 1-03 Torque Characteristics</i> .

3.5.6 3-9* Digital Pot.Meter

Use the digital potentiometer function to increase or decrease the actual reference by adjusting the set-up of the digital inputs using the functions increase, decrease, or clear. To activate the function, at least 1 digital input must be set to increase or decrease.

3-90 Step Size		
Range:	Function:	
0.10 % *	[0.01 - 200 %]	Enter the increment size required for increase/decrease as a percentage of the synchronous motor speed, n_s . If increase/decrease is activated, the resulting reference is increased or decreased by the value set in this parameter.

3-91 Ramp Time		
Range:	Function:	
1 s	[0 - 3600 s]	Enter the ramp time, that is the time for adjustment of the reference 0–100% of the specified digital potentiometer function (increase, decrease, or clear). If increase/decrease is activated for longer than the ramp delay period specified in <i>parameter 3-95 Ramp Delay</i> , the actual reference is ramped up/down according to this ramp time. The ramp time is defined as the time spent to adjust the reference by the step size specified in <i>parameter 3-90 Step Size</i> .

3-92 Power Restore		
Option:	Function:	
[0] *	Off	Resets the digital potentiometer reference to 0% after power-up.
[1]	On	Restores the most recent digital potentiometer reference at power-up.

3-93 Maximum Limit		
Range:	Function:	
100 %*	[-200 - 200 %]	Set the maximum allowed value for the resulting reference. This is recommended if the digital potentiometer is used for fine-tuning of the resulting reference.

3-94 Minimum Limit		
Range:	Function:	
0 %*	[-200 - 200 %]	Set the minimum allowed value for the resulting reference. This is advisable if the digital potentiometer is used for fine-tuning of the resulting reference.

3-95 Ramp Delay		
Range:	Function:	
1*	[0 - 3600]	Enter the delay required from activation of the digital potentiometer function until the frequency converter starts to ramp the reference. With a delay of 0 ms, the reference starts to ramp as soon as increase/decrease is activated. See also <i>parameter 3-91 Ramp Time</i> .

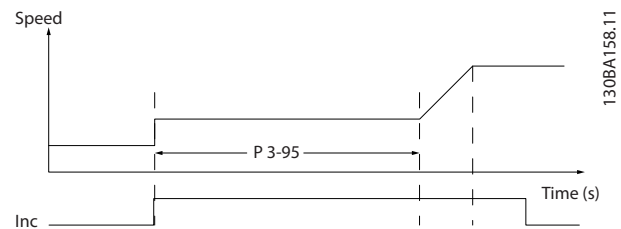

Illustration 3.22 Ramp Delay Case 1

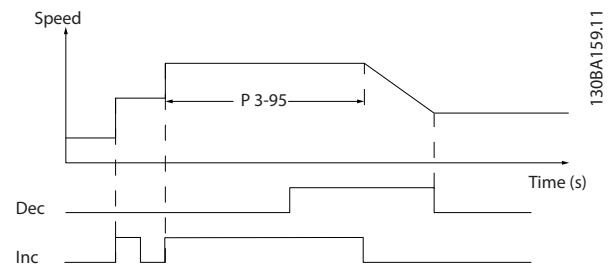

Illustration 3.23 Ramp Delay Case 2

3.6 Parameters: 4-** Limits/Warnings

3.6.1 4-1* Motor Limits

Define torque, current, and speed limits for the motor, and the reaction of the frequency converter when the limits are exceeded.

A limit may generate a message in the display. A warning always generates a message in the display or on the fieldbus. A monitoring function may initiate a warning or a trip, after which the frequency converter stops and generates an alarm message.

4-10 Motor Speed Direction		
Option:	Function:	
		<p>NOTICE</p> <p>The setting in <i>parameter 4-10 Motor Speed Direction</i> has impact on the flying start in <i>parameter 1-73 Flying Start</i>.</p> <p>Selects the motor speed direction required. Use this parameter to prevent unwanted reversing.</p>
[0] *	Clockwise	Only operation in clockwise direction is allowed.
[2]	Both directions	Operation in both clockwise and counter-clockwise direction is allowed.

4-11 Motor Speed Low Limit [RPM]		
Range:	Function:	
Size related* 4-13 RPM	[0 - par. 4-13 RPM]	Enter the minimum limit for motor speed in RPM. The motor speed low limit can be set to correspond to the minimum motor speed recommended by the manufacturer. The motor speed low limit must not exceed the setting in <i>parameter 4-13 Motor Speed High Limit [RPM]</i> .

4-12 Motor Speed Low Limit [Hz]		
Range:	Function:	
Size related* 4-14 Hz	[0 - par. 4-14 Hz]	Enter the minimum limit for motor speed in Hz. The motor speed low limit can be set to correspond to the minimum output frequency of the motor shaft. The speed low limit must not exceed the setting in <i>parameter 4-14 Motor Speed High Limit [Hz]</i> .

4-13 Motor Speed High Limit [RPM]		
Range:	Function:	
Size related* 4-11 - 60000 RPM]	[par. 4-11 - 60000 RPM]	<p>NOTICE</p> <p>Any changes in <i>parameter 4-13 Motor Speed High Limit [RPM]</i> reset the value in <i>parameter 4-53 Warning Speed High</i> to the value set in <i>parameter 4-13 Motor Speed High Limit [RPM]</i>.</p> <p>NOTICE</p> <p>Maximum output frequency cannot exceed 10% of the inverter switching frequency (<i>parameter 14-01 Switching Frequency</i>).</p> <p>Enter the maximum limit for motor speed in RPM. The motor speed high limit can be set to correspond to the manufacturer's maximum rated motor. The motor speed high limit must exceed the setting in <i>parameter 4-11 Motor Speed Low Limit [RPM]</i>.</p> <p>The parameter name appears as either <i>parameter 4-11 Motor Speed Low Limit [RPM]</i> or <i>parameter 4-12 Motor Speed Low Limit [Hz]</i>, depending on:</p> <ul style="list-style-type: none"> The settings of other parameters in the <i>Main Menu</i>. Default settings based on geographical location.

4-14 Motor Speed High Limit [Hz]		
Range:	Function:	
Size related* 4-12 - 4-19 Hz]	[par. 4-12 - 4-19 Hz]	Enter the maximum limit for motor speed in Hz. <i>Parameter 4-14 Motor Speed High Limit [Hz]</i> can be set to correspond to the manufacturer's recommended maximum motor speed. The motor speed high limit must exceed the value in <i>parameter 4-12 Motor Speed Low Limit [Hz]</i> . The output frequency must not exceed 10% of the switching frequency (<i>parameter 14-01 Switching Frequency</i>).

4-16 Torque Limit Motor Mode		
Range:	Function:	
110 %*	[0 - 1000.0 %]	Enter the maximum torque limit for motor operation. The torque limit is active in the speed range up to and including the nominal motor speed set in <i>parameter 1-25 Motor Nominal Speed</i> . To protect the motor from reaching the stalling torque, the default setting is 1.1 x the rated motor torque (calculated value). See also <i>parameter 14-25 Trip Delay at Torque Limit</i> for further details. If a setting in <i>parameter 1-00 Configuration Mode</i> to <i>parameter 1-28 Motor Rotation Check</i> is changed, <i>parameter 4-16 Torque Limit Motor Mode</i> is not automatically reset to the default setting.

4-17 Torque Limit Generator Mode		
Range:	Function:	
100 %*	[0 - 1000.0 %]	Enter the maximum torque limit for generator-mode operation. The torque limit is active in the speed range up to and including the nominal motor speed (<i>parameter 1-25 Motor Nominal Speed</i>). Refer to <i>parameter 14-25 Trip Delay at Torque Limit</i> for further details. If a setting in <i>parameter 1-00 Configuration Mode</i> to <i>parameter 1-28 Motor Rotation Check</i> is changed, <i>parameter 4-17 Torque Limit Generator Mode</i> is not automatically reset to the default settings.

4-18 Current Limit		
Range:	Function:	
Size related*	[1.0 - 1000.0 %]	Enter the current limit for motor and generator operation. To protect the motor from reaching the stalling torque, the default setting is 1.1 x the rated motor current (set in <i>parameter 1-24 Motor Current</i>). If a setting in <i>parameter 1-00 Configuration Mode</i> to <i>parameter 1-28 Motor Rotation Check</i> is changed, <i>parameter 4-16 Torque Limit Motor Mode</i> to <i>parameter 4-18 Current Limit</i> are not automatically reset to the default settings.

4-19 Max Output Frequency		
Range:	Function:	
Size related*	[1 - 590 Hz]	NOTICE This parameter cannot be adjusted while the motor is running. Enter the maximum output frequency value. <i>Parameter 4-19 Max Output Frequency</i> specifies the absolute limit on the frequency converter output frequency for improved safety in

4-19 Max Output Frequency		
Range:	Function:	
		applications where accidental overspeeding must be avoided. This absolute limit applies to all configurations and is independent of the setting in <i>parameter 1-00 Configuration Mode</i> . When <i>parameter 1-10 Motor Construction</i> is set to [1] PM non-salient SPM, the maximum value is limited to 300 Hz.

3.6.2 4-5* Adj. Warnings

Define adjustable warning limits for current, speed, reference, and feedback.

NOTICE

Not visible in the display, only in MCT 10 Set-up Software.

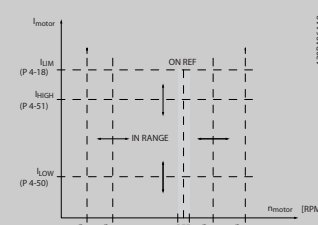
4-50 Warning Current Low		
Range:	Function:	
0 A*	[0 - par. 4-51 A]	Warnings are shown on the display, programmed output, or fieldbus.  Illustration 3.24 Low Current Limit Enter the I_{LOW} value. When the motor current drops below this limit (I_{LOW}), the display reads <i>Current low</i> . The signal outputs can be programmed to produce a status signal on terminal 27 or 29, and on relay output 01 or 02. Refer to <i>Illustration 3.24</i> .

4-51 Warning Current High		
Range:	Function:	
Size related*	[par. 4-50 - par. 16-37 A]	Enter the I_{HIGH} value. When the motor current exceeds this limit (I_{HIGH}), the display reads <i>Current high</i> . The signal outputs can be programmed to produce a status signal on terminal 27 or 29, and on relay output 01 or 02. Refer to <i>Illustration 3.24</i> .

4-52 Warning Speed Low		
Range:	Function:	
0 RPM* [0 - par. 4-53 RPM]	Enter the n_{LOW} value. When the motor speed drops below this limit (n_{LOW}), the display reads <i>Speed Low</i> . The signal outputs can be programmed to produce a status signal on terminal 27 or 29, and on relay output 01 or 02. Program the lower signal limit of the motor speed, n_{LOW} , within the normal working range of the frequency converter. Refer to the <i>Illustration 3.24</i> .	

4-53 Warning Speed High		
Range:	Function:	
Size related* [par. 4-52 - 60000 RPM]	<p>NOTICE</p> <p>Any changes in <i>parameter 4-13 Motor Speed High Limit [RPM]</i> reset the value in <i>parameter 4-53 Warning Speed High</i> to the same value as set in <i>parameter 4-13 Motor Speed High Limit [RPM]</i>.</p> <p>If a different value is needed in <i>parameter 4-53 Warning Speed High</i>, it must be set after programming of <i>parameter 4-13 Motor Speed High Limit [RPM]</i>.</p> <p>Enter the n_{HIGH} value. When the motor speed exceeds this limit (n_{HIGH}), the display reads <i>Speed high</i>. The signal outputs can be programmed to produce a status signal on terminal 27 or 29, and on relay output 01 or 02. Program the upper signal limit of the motor speed, n_{HIGH}, within the normal working range of the frequency converter. Refer to <i>Illustration 3.24</i>.</p>	

4-54 Warning Reference Low		
Range:	Function:	
-999999* [-999999.999 - par. 4-55]	Enter the lower reference limit. When the actual reference drops below this limit, the display indicates Ref_{Low} . The signal outputs can be programmed to produce a status signal on terminal 27 or 29, and on relay output 01 or 02.	

4-55 Warning Reference High		
Range:	Function:	
999999* [par. 4-54 - 999999.999]	Enter the upper reference limit. When the actual reference exceeds this limit, the display reads Ref_{High} . The signal outputs can be programmed to produce a status signal on terminal 27 or 29, and on relay output 01 or 02.	

4-56 Warning Feedback Low		
Range:	Function:	
-999999 ReferenceFeedbackUnit* [-999999.999 - par. 4-57 ReferenceFeedbackUnit]	Enter the lower feedback limit. When the feedback drops below this limit, the display reads $Feedb_{Low}$. The signal outputs can be programmed to produce a status signal on terminal 27 or 29, and on relay output 01 or 02.	

4-57 Warning Feedback High		
Range:	Function:	
999999 ReferenceFeedbackUnit* [par. 4-56 - 999999.999 ReferenceFeedbackUnit]	Enter the upper feedback limit. When the feedback exceeds this limit, the display reads $Feedb_{High}$. The signal outputs can be programmed to produce a status signal on terminal 27 or 29, and on relay output 01 or 02.	

4-58 Missing Motor Phase Function		
Option:	Function:	
	<p>NOTICE</p> <p>This parameter cannot be adjusted while the motor is running.</p> <p>Shows an alarm if motor phase is missing.</p>	
[0] Disabled	No alarm is shown if a missing motor phase occurs.	
[2] Trip 1000 ms		

4-59 Motor Check At Start		
Select whether the frequency converter performs the 3-phase motor check at start		
Option:	Function:	
[0] *	Off	
[1]	On	

3.6.3 4-6* Speed Bypass

Some systems require that certain output frequencies or speeds are avoided due to resonance problems in the system. A maximum of 4 frequency or speed ranges can be avoided.

4-60 Bypass Speed From [RPM]		
Array [4]		
Range:		Function:
Size related*	[0 - par. 4-13 RPM]	Some systems require that certain output frequencies or speeds are avoided due to resonance problems in the system. Enter the lower limits of the speeds to be avoided.

4-61 Bypass Speed From [Hz]		
Array [4]		
Range:		Function:
Size related*	[0 - par. 4-14 Hz]	Some systems require that certain output frequencies or speeds are avoided due to resonance problems in the system. Enter the lower limits of the speeds to be avoided.

4-62 Bypass Speed To [RPM]		
Array [4]		
Range:		Function:
Size related*	[0 - par. 4-13 RPM]	Some systems require that certain output frequencies or speeds are avoided due to resonance problems in the system. Enter the upper limits of the speeds to be avoided.

4-63 Bypass Speed To [Hz]		
Array [4]		
Range:		Function:
Size related*	[0 - par. 4-14 Hz]	Some systems require that certain output frequencies or speeds are avoided due to resonance problems in the system. Enter the upper limits of the speeds to be avoided.

3.6.4 Semi-Automatic Bypass Speed Set-up

Use the semi-automatic bypass speed set-up to facilitate the programming of the frequencies to be skipped due to resonances in the system.

Carry out following process:

1. Stop the motor.
2. Select [1] Enabled in parameter 4-64 Semi-Auto Bypass Set-up.
3. Press [Hand On] on the LCP to start the search for frequency bands causing resonances. The motor ramps up according to the ramp set.
4. When sweeping through a resonance band, press [OK] on the LCP when leaving the band. The actual frequency is stored as the first element in parameter 4-62 Bypass Speed To [RPM] or parameter 4-63 Bypass Speed To [Hz] (array). Repeat this for each resonance band identified at the ramp-up (maximum 4 can be adjusted).
5. When maximum speed has been reached, the motor automatically begins to ramp down. Repeat the above procedure when speed is leaving the resonance bands during the deceleration. The actual frequencies registered when pressing [OK] are stored in parameter 4-60 Bypass Speed From [RPM] or parameter 4-61 Bypass Speed From [Hz].
6. When the motor has ramped down to stop, press [OK]. Parameter 4-64 Semi-Auto Bypass Set-up automatically resets to Off. The frequency converter stays in Hand mode until [Off] or [Auto On] is pressed on the LCP.

If the frequencies for a certain resonance band are not registered in the right order (frequency values stored in parameter 4-62 Bypass Speed To [RPM] are higher than those in parameter 4-60 Bypass Speed From [RPM]), or if they do not have the same numbers of registrations for the Bypass From and Bypass To, all registrations are canceled and the following message is shown: *Collected speed areas overlapping or not completely determined. Press [Cancel] to abort.*

4-64 Semi-Auto Bypass Set-up		
Option:	Function:	
[0] *	Off	No function.
[1]	Enabled	Starts the semi-automatic bypass set-up and continues with the procedure described in chapter 3.6.4 Semi-Automatic Bypass Speed Set-up.

3.7 Parameters: 5-** Digital In/Out

Parameter group for configuring the digital input and output.

3.7.1 5-0* Digital I/O Mode

Parameters for configuring the input and output using NPN and PNP.

5-00 Digital I/O Mode		
Option:	Function:	
		<p>NOTICE This parameter cannot be adjusted while the motor is running.</p> <p>Digital inputs and programmed digital outputs are pre-programmable for operation either in PNP or NPN systems.</p>
[0] *	PNP - Active at 24V	Action on positive directional pulses (0). PNP systems are pulled down to GND.
[1]	NPN - Active at 0V	Action on negative directional pulses (1). NPN systems are pulled up to +24 V, internally in the frequency converter.

5-01 Terminal 27 Mode		
Option:	Function:	
		<p>NOTICE This parameter cannot be adjusted while the motor is running.</p>
[0] *	Input	Defines terminal 27 as a digital input.
[1]	Output	Defines terminal 27 as a digital output.

5-02 Terminal 29 Mode		
Option:	Function:	
		<p>NOTICE This parameter cannot be adjusted while the motor is running.</p>
[0] *	Input	Defines terminal 29 as a digital input.
[1]	Output	Defines terminal 29 as a digital output.

3.7.2 5-1* Digital Inputs

Parameters for configuring the input functions for the input terminals.

The digital inputs are used for selecting various functions in the frequency converter. All digital inputs can be set to the following functions:

Digital input function	Option	Terminal
No operation	[0]	All terminal 32, 33
Reset	[1]	All
Coast inverse	[2]	All
Coast and reset inverse	[3]	All
DC-brake inverse	[5]	All
Stop inverse	[6]	All
External interlock	[7]	All
Start	[8]	All terminal 18
Latched start	[9]	All
Reversing	[10]	All terminal 19
Start reversing	[11]	All
Jog	[14]	All terminal 29
Preset reference on	[15]	All
Preset ref bit 0	[16]	All
Preset ref bit 1	[17]	All
Preset ref bit 2	[18]	All
Freeze reference	[19]	All
Freeze output	[20]	All
Speed up	[21]	All
Speed down	[22]	All
Set-up select bit 0	[23]	All
Set-up select bit 1	[24]	All
Ramp bit 0	[34]	All
Mains failure inverse	[36]	All
Fire mode	[37]	-
Day/night control	[39]	-
Run permissive	[52]	-
Hand start	[53]	-
Auto start	[54]	-
DigiPot increase	[55]	All
DigiPot decrease	[56]	All
DigiPot clear	[57]	All
Reset counter A	[62]	All
Reset counter B	[65]	All
Sleep mode	[66]	-
Reset maintenance word	[78]	-
Lead compressor start	[120]	-
Lead compressor alternation	[121]	-
Compressor 1 interlock	[130]	-
Compressor 2 interlock	[131]	-
Compressor 3 interlock	[132]	-
Comp. 1 Inv. interlock	[139]	-
Comp. 2 Inv. interlock	[140]	-
Comp. 3 Inv. interlock	[141]	-

Table 3.8 Digital Input Functions

All = Terminals 18, 19, 27, 29, 32, 33, X30/2, X30/3, X30/4.
X30/X are the terminals on VLT® General Purpose I/O MCB 101.

Functions dedicated to only 1 digital input are stated in the associated parameter.

All digital inputs can be programmed to these functions:

3

[0]	No operation	No reaction to signals transmitted to terminal.
[1]	Reset	Resets frequency converter after a trip/alarm. Not all alarms can be reset.
[2]	Coast inverse	Leaves motor in free mode. Logic 0⇒coasting stop. (Default digital input 27): Coasting stop, inverted input (NC).
[3]	Coast and reset inverse	Reset and coasting stop, inverted input (NC). Leaves motor in free mode and resets the frequency converter. Logic 0⇒coasting stop and reset.
[5]	DC-brake inverse	Inverted input for DC braking (NC). Stops motor by energizing it with a DC current for a certain time period. See <i>parameter 2-01 DC Brake Current</i> to <i>parameter 2-03 DC Brake Cut In Speed [RPM]</i> . The function is only active when the value in <i>parameter 2-02 DC Braking Time</i> is different from 0. Logic 0⇒DC braking. This selection is not possible when <i>parameter 1-10 Motor Construction</i> is set to [1] PM, non salient SPM.
[6]	Stop inverse	Stop inverted function. Generates a stop function when the selected terminal goes from logical level 1 to 0. The stop is performed according to the selected ramp time in: <ul style="list-style-type: none"> Parameter 3-42 Ramp 1 Ramp Down Time. Parameter 3-52 Ramp 2 Ramp Down Time. <p>NOTICE When the frequency converter is at the torque limit and has received a stop command, it may not stop by itself. To ensure that the frequency converter stops, configure a digital output to [27] Torque limit & stop and connect this digital output to a digital input that is configured as coast.</p>
[7]	External Interlock	Same function as coasting inverse and stop inverse, but this option generates the alarm message <i>External fault</i> on the display when the terminal programmed for coast inverse has signal 0. The alarm message is also active via digital outputs and relay outputs, if programmed for external interlock. When the external interlock is removed, the alarm can be reset using a digital input or the [Reset] key. A delay can be programmed in

		<i>parameter 22-00 External Interlock Delay</i> . After applying a signal to the input, the reaction described above is delayed with the time set in <i>parameter 22-00 External Interlock Delay</i> .																																				
[8]	Start	Select start for a start/stop command. Logic 1=start, logic 0=stop. (Default: Digital input 18).																																				
[9]	Latched start	The motor starts if a pulse is applied for minimum 2 ms. The motor stops when stop inverse is activated.																																				
[10]	Reversing	Changes direction of motor shaft rotation. Select logic 1 to reverse. The reversing signal only changes the direction of rotation. It does not activate the start function. Select [2] Both directions in <i>parameter 4-10 Motor Speed Direction</i> . (Default: Digital input 19).																																				
[11]	Start reversing	Used for start/stop and for reversing on the same wire. Signals on start are not allowed at the same time.																																				
[14]	Jog	Used for activating jog speed. See <i>parameter 3-11 Jog Speed [Hz]</i> . (Default: Digital input 29)																																				
[15]	Preset reference on	Used for shifting between external reference and preset reference. It is assumed that <i>External/preset [1]</i> has been selected in <i>parameter 3-04 Reference Function</i> . Logic 0=external reference active; logic 1=1 of the 8 preset references is active.																																				
[16]	Preset ref bit 0	Enables a choice between 1 of the 8 preset references according to <i>Table 3.9</i> .																																				
[17]	Preset ref bit 1	Enables a choice between 1 of the 8 preset references according to <i>Table 3.9</i> .																																				
[18]	Preset ref bit 2	Enables a choice between 1 of the 8 preset references according to <i>Table 3.9</i> . <table border="1" data-bbox="1029 1400 1452 1736"> <thead> <tr> <th>Preset reference bit</th> <th>2</th> <th>1</th> <th>0</th> </tr> </thead> <tbody> <tr> <td>Preset reference 0</td> <td>0</td> <td>0</td> <td>0</td> </tr> <tr> <td>Preset reference 1</td> <td>0</td> <td>0</td> <td>1</td> </tr> <tr> <td>Preset reference 2</td> <td>0</td> <td>1</td> <td>0</td> </tr> <tr> <td>Preset reference 3</td> <td>0</td> <td>1</td> <td>1</td> </tr> <tr> <td>Preset reference 4</td> <td>1</td> <td>0</td> <td>0</td> </tr> <tr> <td>Preset reference 5</td> <td>1</td> <td>0</td> <td>1</td> </tr> <tr> <td>Preset reference 6</td> <td>1</td> <td>1</td> <td>0</td> </tr> <tr> <td>Preset reference 7</td> <td>1</td> <td>1</td> <td>1</td> </tr> </tbody> </table> <p>Table 3.9 Digital Inputs Preset Reference Bit</p>	Preset reference bit	2	1	0	Preset reference 0	0	0	0	Preset reference 1	0	0	1	Preset reference 2	0	1	0	Preset reference 3	0	1	1	Preset reference 4	1	0	0	Preset reference 5	1	0	1	Preset reference 6	1	1	0	Preset reference 7	1	1	1
Preset reference bit	2	1	0																																			
Preset reference 0	0	0	0																																			
Preset reference 1	0	0	1																																			
Preset reference 2	0	1	0																																			
Preset reference 3	0	1	1																																			
Preset reference 4	1	0	0																																			
Preset reference 5	1	0	1																																			
Preset reference 6	1	1	0																																			
Preset reference 7	1	1	1																																			
[19]	Freeze ref	Freezes the actual reference. The frozen reference is now the point of enable/condition for speed up and speed down to be used. If speed up/down is used, the speed change always follows ramp 2 (<i>parameter 3-51 Ramp 2 Ramp Up Time</i> and																																				

		<i>parameter 3-52 Ramp 2 Ramp Down Time</i> in the range 0– <i>parameter 3-03 Maximum Reference</i> .
[20]	Freeze output	Freezes actual motor frequency (Hz). The frozen motor frequency is now the point of enable/condition for speed up and speed down to be used. If speed up/down is used, the speed change always follows ramp 2 (<i>parameter 3-51 Ramp 2 Ramp Up Time</i> and <i>parameter 3-52 Ramp 2 Ramp Down Time</i>) in the range 0– <i>parameter 1-23 Motor Frequency</i> . NOTICE When freeze output is active, the frequency converter cannot be stopped via a low [13] start signal. Stop the frequency converter via a terminal programmed for [2] Coasting inverse or [3] Coast and reset, inverse.
[21]	Speed up	Select [21] Speed up and [22] Speed down if digital control of the up/down speed is desired (motor potentiometer). Activate this function by selecting either [19] Freeze ref or [20] Freeze output. When speed up/down is activated for less than 400 ms, the resulting reference is increased/decreased by 0.1%. If speed up/down is activated for more than 400 ms, the resulting reference follows the setting in ramping up/down <i>parameters 3-x1/3-x2</i> .
[22]	Speed down	Same as [21] Speed up.
[23]	Set-up select bit 0	Selects 1 of the 4 set-ups. Set <i>parameter 0-10 Active Set-up</i> to [9] Multi Set-up.
[24]	Set-up select bit 1	Same as [23] Set-up select bit 0. (Default: Digital input 32).
[34]	Ramp bit 0	Select which ramp to use. Logic 0 selects ramp 1, while logic 1 selects ramp 2.
[37]	Fire mode	A signal applied puts the frequency converter into fire mode and all other commands are disregarded. See <i>parameter group 24-0* Fire Mode</i> .
[39]	Day/ Night Control	Day or night indication for day/night control feature. Low voltage on the selected digital input indicates day, while high voltage indicates night.
[52]	Run Permissive	The input terminal, for which the run permissive has been programmed must be logic 1 before a start command can be accepted. Run permissive has a logic AND function related to the terminal which is programmed for [8] Start, [14] Jog, or [20] Freeze Output. To start running the motor, both conditions must be fulfilled. If run permissive is programmed on multiple terminals, [52] Run permissive only has to be logic 1 on 1 of the terminals to carry out the function. The digital output signal for run

		request ([8] Start, [14] Jog, or [20] Freeze output) programmed in <i>parameter group 5-3* Digital Outputs</i> , or <i>parameter group 5-4* Relays</i> , is not affected by run permissive. NOTICE If no run permissive signal is applied, but either run, jog, or freeze commands are activated, the status line in the display shows either Run Requested, Jog Requested, or Freeze Requested.
[53]	Hand start	A signal applied puts the frequency converter into hand-on mode as if [Hand On] was pressed on the LCP, and a normal stop command is overridden. If disconnecting the signal, the motor stops. To make any other start commands valid, assign another digital input to [54] Auto Start and apply a signal to this. The [Hand On] and [Auto On] keys on the LCP have no impact. The [Off] key on the LCP overrides [53] Hand Start and [54] Auto Start. Press either [Hand On] or [Auto On] to reactivate [53] Hand Start and [54] Auto Start. If no signal on neither [53] Hand Start nor [54] Auto Start, the motor stops regardless of any normal start command applied. If signals are applied to both [53] Hand Start and [54] Auto Start, the function is auto start. If pressing [Off] on the LCP, the motor stops regardless of signals on [53] Hand Start and [54] Auto Start.
[54]	Auto start	A signal applied puts the frequency converter into auto-on mode as if [Auto On] has been pressed. See also [53] Hand Start.
[55]	DigiPot Increase	Uses the input as an increase signal to the digital potentiometer function described in <i>parameter group 3-9* Digital Pot.Meter</i> .
[56]	DigiPot Decrease	Uses the input as a decrease signal to the digital potentiometer function described in <i>parameter group 3-9* Digital Pot.Meter</i> .
[57]	DigiPot Clear	Uses the input to clear the digital potentiometer reference described in <i>parameter group 3-9* Digital Pot.Meter</i> .
[62]	Reset Counter A	Input for reset of counter A.
[65]	Reset Counter B	Input for reset of counter B.
[66]	Sleep Mode	Forces frequency converter into sleep mode (see <i>parameter group 22-4* Sleep Mode</i>). Reacts on the rising edge of signal applied.
[78]	Reset Preventive Maintenance Word	Resets all data in <i>parameter 16-96 Maintenance Word</i> to 0.

The below setting options are all related to the pack controller. Wiring diagrams and settings for parameter, see *parameter group 25-** Pack Controller* for more details.

[120]	Lead Compressor Start	Starts or stops the lead compressor controlled by the frequency converter. A start requires that a system start signal is applied, for example to 1 of the digital inputs set for [8] Start.															
[121]	Lead Compressor Alternation	Forces alternation of the lead compressor in a pack controller. Set <i>parameter 25-50 Lead Pump Alternation</i> to either [2] At Command or [3] At Staging or At Command. Set <i>parameter 25-51 Alternation Event</i> to any option.															
[130 - 132]	Compressor 1 Interlock - Compressor 3 Interlock	Set <i>parameter 25-90 Compressor Interlock</i> to [1] On. The option depends on the setting in <i>parameter 25-06 Number of Compressors</i> . If this option is set to [0] No, compressor 1 refers to the compressor controlled by relay 1, and so on. If this option is set to [1] Yes, compressor 1 refers to the compressor controlled by the frequency converter only (without any of the built-in relays involved) and compressor 2 refers to the compressor controlled by relay 1. Variable speed compressor (lead) cannot be interlocked.															
		<table border="1"> <thead> <tr> <th>Setting in parameter group 5-1* Digital Inputs</th> <th colspan="2">Setting in parameter 25-06 Number of Compressors</th> </tr> <tr> <td></td> <th>[0] No</th> <th>[1] Yes</th> </tr> </thead> <tbody> <tr> <td>[130] Compressor 1 Interlock</td> <td>Controlled by relay 1 (only if not lead compressor)</td> <td>Controlled by the frequency converter (cannot be interlocked)</td> </tr> <tr> <td>[131] Compressor 2 Interlock</td> <td>Controlled by relay 2</td> <td>Controlled by relay 1</td> </tr> <tr> <td>[132] Compressor 3 Interlock</td> <td>Controlled by relay 3</td> <td>Controlled by relay 2</td> </tr> </tbody> </table>	Setting in parameter group 5-1* Digital Inputs	Setting in parameter 25-06 Number of Compressors			[0] No	[1] Yes	[130] Compressor 1 Interlock	Controlled by relay 1 (only if not lead compressor)	Controlled by the frequency converter (cannot be interlocked)	[131] Compressor 2 Interlock	Controlled by relay 2	Controlled by relay 1	[132] Compressor 3 Interlock	Controlled by relay 3	Controlled by relay 2
Setting in parameter group 5-1* Digital Inputs	Setting in parameter 25-06 Number of Compressors																
	[0] No	[1] Yes															
[130] Compressor 1 Interlock	Controlled by relay 1 (only if not lead compressor)	Controlled by the frequency converter (cannot be interlocked)															
[131] Compressor 2 Interlock	Controlled by relay 2	Controlled by relay 1															
[132] Compressor 3 Interlock	Controlled by relay 3	Controlled by relay 2															
		Table 3.10 Compressor 1 Interlock - Compressor 3 Interlock															
[139]	Compressor 1 Inverse Interlock	Interlocks compressor 1 from the pack controller when the signal is low and issues <i>warning 219, Compressor Interlock</i> . When inversely interlocked, compressor 1 (the lead compressor) is staged according to <i>parameter 25-23 Fixed Speed neutral Zone [unit]</i> .															

[140]	Compressor 2 Inverse Interlock	Interlocks compressor 2 from the pack controller when the signal is low and issues <i>warning 219, Compressor Interlock</i> .
[141]	Compressor 3 Inverse Interlock	Interlocks compressor 3 from the pack controller when the signal is low and issues <i>warning 219, Compressor Interlock</i> .

5-10 Terminal 18 Digital Input

The parameter contains all options and functions listed in *parameter group 5-1* Digital Inputs*.

5-11 Terminal 19 Digital Input

The parameter contains all options and functions listed in *parameter group 5-1* Digital Inputs*.

5-12 Terminal 27 Digital Input

The parameter contains all options and functions listed in *parameter group 5-1* Digital Inputs*.

5-13 Terminal 29 Digital Input

The parameter contains all options and functions listed in *parameter group 5-1* Digital Inputs*. This parameter also contains options [60] Counter A (up), [61] Counter A (down), [63] Counter B (up), and [64] Counter B (down) for smart logic control.

5-14 Terminal 32 Digital Input

The parameter contains all options and functions listed in *parameter group 5-1* Digital Inputs*. This parameter also contains options [60] Counter A (up), [61] Counter A (down), [63] Counter B (up), and [64] Counter B (down) for smart logic control.

5-15 Terminal 33 Digital Input

The parameter contains all options and functions listed in *parameter group 5-1* Digital Inputs*. This parameter also contains options [60] Counter A (up), [61] Counter A (down), [63] Counter B (up), and [64] Counter B (down) for smart logic control.

5-16 Terminal X30/2 Digital Input

This parameter is active when VLT® General Purpose I/O MCB 101 is installed in the frequency converter. The parameter contains all options and functions listed in *parameter group 5-1* Digital Inputs*.

5-17 Terminal X30/3 Digital Input

This parameter is active when VLT® General Purpose I/O MCB 101 is installed in the frequency converter. The parameter contains all options and functions listed in *parameter group 5-1* Digital Inputs*.

5-18 Terminal X30/4 Digital Input

This parameter is active when VLT® General Purpose I/O MCB 101 is installed in the frequency converter. The parameter contains all options and functions listed in *parameter group 5-1* Digital Inputs*.

5-19 Terminal 37 Safe Stop		
Use this parameter to configure the Safe Torque Off functionality. A warning message makes the frequency converter coast the motor and enables the automatic restart. An alarm message makes the frequency converter coast the motor and requires a manual restart (via a fieldbus, Digital I/O, or by pressing [RESET] on the LCP). When the VLT® PTC Thermistor Card MCB 112 is mounted, configure the PTC options to get the full benefit from the alarm handling.		
Option:	Function:	
[1]	Safe Stop Alarm	Coasts the frequency converter when Safe Torque Off is activated. Manual reset from LCP, digital input, or fieldbus.
[3]	Safe Stop Warning	Coasts the frequency converter when Safe Torque Off is activated (terminal 37 off). When the Safe Torque Off circuit is re-established, the frequency converter continues without manual reset.
[4]	PTC 1 Alarm	Coasts the frequency converter when Safe Torque Off is activated. Manual reset from LCP, digital input, or fieldbus.
[5]	PTC 1 Warning	Coasts the frequency converter when Safe Torque Off is activated (terminal 37 off). When the Safe Torque Off circuit is re-established, the frequency converter continues without manual reset, unless a digital input set to [80] PTC Card 1 is still enabled.
[6]	PTC 1 & Relay A	This option is used when the VLT® PTC Thermistor Card MCB 112 gates with a stop key through a safety relay to terminal 37. Coasts the frequency converter when Safe Torque Off is activated. Manual reset from LCP, digital input, or fieldbus.
[7]	PTC 1 & Relay W	This option is used when the VLT® PTC Thermistor Card MCB 112 gates with a stop key through a safety relay to terminal 37. Coasts the frequency converter when Safe Torque Off is activated (terminal 37 off). When the Safe Torque Off circuit is re-established, the frequency converter continues without manual reset, unless a digital input set to [80] PTC Card 1 is still enabled.
[8]	PTC 1 & Relay A/W	This option makes it possible to use a combination of alarm and warning.
[9]	PTC 1 & Relay W/A	This option makes it possible to use a combination of alarm and warning.

NOTICE

Options [4] PTC 1 Alarm to [9] PTC 1 & Relay W/A are only available when the MCB 112 is connected.

NOTICE

Selecting Auto Reset/Warning enables automatic restart of the frequency converter.

Function	Number	PTC	Relay
No Function	[0]	–	–
Safe Torque Off Alarm	[1]*	–	Safe Torque Off [A68]
Safe Torque Off Warning	[3]	–	Safe Torque Off [W68]
PTC 1 Alarm	[4]	PTC 1 Safe Torque Off [A71]	–
PTC 1 Warning	[5]	PTC 1 Safe Torque Off [W71]	–
PTC 1 & Relay A	[6]	PTC 1 Safe Torque Off [A71]	Safe Torque Off [A68]
PTC 1 & Relay W	[7]	PTC 1 Safe Torque Off [W71]	Safe Torque Off [W68]
PTC 1 & Relay A/W	[8]	PTC 1 Safe Torque Off [A71]	Safe Torque Off [W68]
PTC 1 & Relay W/A	[9]	PTC 1 Safe Torque Off [W71]	Safe Torque Off [A68]

Table 3.11 Overview of Functions, Alarms, and Warnings

W means warning and A means alarm. For further information, see Alarms and Warnings in the Troubleshooting section in the design guide or the operating instructions.

A dangerous failure related to Safe Torque Off issues *alarm 72, Dangerous Failure*.

Refer to Table 5.3.

5-20 Terminal X46/1 Digital Input

This parameter is related to the digital input on VLT® Extended Relay Card MCB 113. The parameter contains all options and functions listed in *parameter group 5-1* Digital Inputs* except for option [32] Pulse input.

5-21 Terminal X46/3 Digital Input

This parameter is related to the digital input on VLT® Extended Relay Card MCB 113. The parameter contains all options and functions listed in *parameter group 5-1* Digital Inputs* except for option [32] Pulse input.

5-22 Terminal X46/5 Digital Input

This parameter is related to the digital input on VLT® Extended Relay Card MCB 113. The parameter contains all options and functions listed in *parameter group 5-1* Digital Inputs* except for option [32] Pulse input.

5-23 Terminal X46/7 Digital Input

This parameter is related to the digital input on VLT® Extended Relay Card MCB 113. The parameter contains all options and functions listed in *parameter group 5-1* Digital Inputs* except for option [32] Pulse input.

5-24 Terminal X46/9 Digital Input

This parameter is related to the digital input on VLT® Extended Relay Card MCB 113. The parameter contains all options and functions listed in *parameter group 5-1* Digital Inputs* except for option [32] Pulse input.

5-25 Terminal X46/11 Digital Input

This parameter is related to the digital input on VLT® Extended Relay Card MCB 113. The parameter contains all options and functions listed in *parameter group 5-1* Digital Inputs* except for option [32] Pulse input.

5-26 Terminal X46/13 Digital Input

This parameter is related to the digital input on VLT® Extended Relay Card MCB 113. The parameter contains all options and functions listed in *parameter group 5-1* Digital Inputs* except for option [32] Pulse input.

3.7.3 5-3* Digital Outputs

Parameters for configuring the output functions for the output terminals. The 2 solid-state digital outputs are common for terminals 27 and 29. Set the I/O function for terminal 27 in *parameter 5-01 Terminal 27 Mode* and set the I/O function for terminal 29 in *parameter 5-02 Terminal 29 Mode*.

NOTICE

These parameters cannot be adjusted while the motor is running.

		The digital outputs can be programmed with these functions:
[0]	No operation	Default for all digital outputs and relay outputs.
[1]	Control ready	The control board receives supply voltage.
[2]	Drive ready	The frequency converter is ready for operation and applies a supply signal on the control board.
[3]	Drive ready / remote control	The frequency converter is ready for operation and is in auto-on mode.
[4]	Stand-by / no warning	The frequency converter is ready for operation. No start or stop command is given (start/disable). There are no warnings.
[5]	Running	The motor is running.
[6]	Running / no warning	The output speed is higher than the speed set in <i>parameter 1-81 Min Speed for</i>

		<i>Function at Stop [RPM]</i> . The motor is running, and there are no warnings.
[8]	Run on reference / no warning	The motor is running at reference speed.
[9]	Alarm	An alarm activates the output. There are no warnings.
[10]	Alarm or warning	An alarm or a warning activates the output.
[11]	At torque limit	The torque limit set in <i>parameter 4-16 Torque Limit Motor Mode</i> or <i>parameter 4-13 Motor Speed High Limit [RPM]</i> has been exceeded.
[12]	Out of current range	The motor current is outside the range set in <i>parameter 4-18 Current Limit</i> .
[13]	Below current, low	The motor current is lower than set in <i>parameter 4-50 Warning Current Low</i> .
[14]	Above current, high	The motor current is higher than set in <i>parameter 4-51 Warning Current High</i> .
[15]	Out of speed range	The output speed is outside the range set in <i>parameter 4-52 Warning Speed Low</i> and <i>parameter 4-53 Warning Speed High</i> .
[16]	Below speed, low	The output speed is lower than the setting in <i>parameter 4-52 Warning Speed Low</i> .
[17]	Above speed, high	The output speed is higher than the setting in <i>parameter 4-53 Warning Speed High</i> .
[18]	Out of feedback range	The feedback is outside the range set in <i>parameter 4-56 Warning Feedback Low</i> and <i>parameter 4-57 Warning Feedback High</i> .
[19]	Below feedback low	The feedback is below the limit set in <i>parameter 4-56 Warning Feedback Low</i> .
[20]	Above feedback high	The feedback is above the limit set in <i>parameter 4-57 Warning Feedback High</i> .
[21]	Thermal warning	The thermal warning turns on when the temperature exceeds the limit in the motor, the frequency converter, the brake resistor, or the thermistor.
[25]	Reverse	The motor is running (or is ready to run) clockwise when there is a logic 0 signal and counterclockwise when there is a logic 1 signal. The output changes as soon as the reversing signal is applied.
[26]	Bus OK	Active communication (no timeout) via the serial communication port.
[27]	Torque limit and stop	Use this option to perform a coasting stop and in torque limit condition. If the frequency converter has received a stop signal and is at the torque limit, the signal is logic 0.
[28]	Brake, no warning	The brake is active and there are no warnings.
[29]	Brake ready, no fault	The brake is ready for operation and there are no faults.

[30]	Brake fault (IGBT)	The output is logic 1 when the brake IGBT is short-circuited. Use this function to protect the frequency converter if there is a fault on the brake modules. Use the output/relay to cut out the main voltage from the frequency converter.
[35]	External Interlock	The external interlock function has been activated via 1 of the digital inputs.
[40]	Out of ref range	
[41]	Below reference low	
[42]	Above reference high	
[45]	Bus Ctrl	
[46]	Bus Ctrl 1 if timeout	
[47]	Bus Ctrl 0 if timeout	
[55]	Pulse output	
[60]	Comtor 0	See <i>parameter group 13-1* Comparators</i> . If comparator 0 is evaluated as TRUE, the output goes high. Otherwise, it is low.
[61]	Comtor 1	See <i>parameter group 13-1* Comparators</i> . If comparator 1 is evaluated as TRUE, the output goes high. Otherwise, it is low.
[62]	Comtor 2	See <i>parameter group 13-1* Comparators</i> . If comparator 2 is evaluated as TRUE, the output goes high. Otherwise, it is low.
[63]	Comtor 3	See <i>parameter group 13-1* Comparators</i> . If comparator 3 is evaluated as TRUE, the output goes high. Otherwise, it is low.
[64]	Comtor 4	See <i>parameter group 13-1* Comparators</i> . If comparator 4 is evaluated as TRUE, the output goes high. Otherwise, it is low.
[65]	Comtor 5	See <i>parameter group 13-1* Comparators</i> . If comparator 5 is evaluated as TRUE, the output goes high. Otherwise, it is low.
[70]	Logic Rule 0	See <i>parameter group 13-4* Logic Rules</i> . If logic rule 0 is evaluated as TRUE, the output goes high. Otherwise, it is low.
[71]	Logic Rule 1	See <i>parameter group 13-4* Logic Rules</i> . If logic rule 1 is evaluated as TRUE, the output goes high. Otherwise, it is low.
[72]	Logic Rule 2	See <i>parameter group 13-4* Logic Rules</i> . If logic rule 2 is evaluated as TRUE, the output goes high. Otherwise, it is low.
[73]	Logic Rule 3	See <i>parameter group 13-4* Logic Rules</i> . If logic rule 3 is evaluated as TRUE, the output goes high. Otherwise, it is low.
[74]	Logic Rule 4	See <i>parameter group 13-4* Logic Rules</i> . If logic rule 4 is evaluated as TRUE, the output goes high. Otherwise, it is low.
[75]	Logic Rule 5	See <i>parameter group 13-4* Logic Rules</i> . If logic rule 5 is evaluated as TRUE, the output goes high. Otherwise, it is low.

[80]	SL Digital Output A	See <i>parameter 13-52 SL Controller Action</i> . The input goes high whenever the smart logic action [38] <i>Set dig. out. A high</i> is executed. The input goes low whenever the smart logic action [32] <i>Set dig. out. A low</i> is executed.
[81]	SL Digital Output B	See <i>parameter 13-52 SL Controller Action</i> . The input goes high whenever the smart logic action [39] <i>Set dig. out. B high</i> is executed. The input goes low whenever the smart logic action [33] <i>Set dig. out. B low</i> is executed.
[82]	SL Digital Output C	See <i>parameter 13-52 SL Controller Action</i> . The input goes high whenever the smart logic action [40] <i>Set dig. out. C high</i> is executed. The input goes low whenever the smart logic action [34] <i>Set dig. out. C low</i> is executed.
[83]	SL Digital Output D	See <i>parameter 13-52 SL Controller Action</i> . The input goes high whenever the smart logic action [41] <i>Set dig. out. D high</i> is executed. The input goes low whenever the smart logic action [35] <i>Set dig. out. D low</i> is executed.
[84]	SL Digital Output E	See <i>parameter 13-52 SL Controller Action</i> . The input goes high whenever the smart logic action [42] <i>Set dig. out. E high</i> is executed. The input goes low whenever the smart logic action [36] <i>Set dig. out. E low</i> is executed.
[85]	SL Digital Output F	See <i>parameter 13-52 SL Controller Action</i> . The input goes high whenever the smart logic action [43] <i>Set dig. out. F high</i> is executed. The input goes low whenever the smart logic action [37] <i>Set dig. out. F low</i> is executed.
[160]	No alarm	The output is high when no alarm is present.
[161]	Running reverse	The output is high when the frequency converter is running counter clockwise (the logical product of the status bits running AND reverse).
[165]	Local reference active	The output is high when <i>parameter 3-13 Reference Site=[2] Local</i> or when <i>parameter 3-13 Reference Site=[0] Linked to hand auto</i> at the same time as the LCP is in hand-on mode.
[166]	Remote reference active	The output is high when <i>parameter 3-13 Reference Site = [1] Remote</i> or [0] <i>Linked to hand/auto</i> while the LCP is in auto-on mode.
[167]	Start command active	The output is high when there is an active start command (that is via digital input, bus connection, [Hand on] or [Auto on]), and no stop command is active.

[168]	Drive in hand mode	The output is high when the frequency converter is in hand-on mode (as indicated by the LED light above [Hand On]).
[169]	Drive in auto mode	The output is high when the frequency converter is in hand-on mode (as indicated by the LED light above [Auto on]).
[180]	Clock Fault	The clock function has been reset to default (2000-01-01) because of a power failure.
[181]	Preventive Maintenance	1 or more of the preventive maintenance events programmed in <i>parameter 23-10 Maintenance Item</i> has passed the time for the specified action in <i>parameter 23-11 Maintenance Action</i> .
[190]	No-Flow	A no-flow condition or minimum speed condition is detected if enabled in <i>parameter 22-21 Low Power Detection</i> and/or <i>parameter 22-22 Low Speed Detection</i> .
[191]	Dry Pump	A dry pump condition is detected. This function must be enabled in <i>parameter 22-26 Dry Pump Function</i> .
[192]	End of Curve	A compressor running with maximum speed for a defined time without reaching the set pressure is detected. To enable this function, see <i>parameter 22-50 End of Curve Function</i> .
[193]	Sleep Mode	The frequency converter/system has turned into sleep mode. See <i>parameter group 22-4* Sleep Mode</i> .
[194]	Broken Belt	A broken-belt condition is detected. This function must be enabled in <i>parameter 22-60 Broken Belt Function</i> .
[195]	Bypass Valve Control	The bypass valve control (digital/relay output in the frequency converter) is used for compressor systems to unload the compressor during start-up by using a bypass valve. After the start command is given, the bypass valve is open until the frequency converter reaches <i>parameter 4-11 Motor Speed Low Limit [RPM]</i> . After the limit has been reached, the bypass valve is closed, allowing the compressor to operate normally. This procedure is not activated again before a new start is initiated, and the frequency converter speed is 0 during the receiving of start signal. <i>Parameter 1-71 Start Delay</i> can be used to delay the motor start.

		<p>Illustration 3.25 Bypass Valve Control Principle</p>
[196]	Fire Mode	The frequency converter is operating in fire mode. See <i>parameter group 24-0* Fire Mode</i> .
[197]	Fire Mode was act.	The frequency converter was operating in fire mode, but is now back to normal operation.
[198]	Drive Bypass	To be used as signal for activating an external electromechanical bypass, switching the motor direct on line. See <i>parameter group 24-1* Drive Bypass</i> . NOTICE If enabling the drive bypass function, the frequency converter is no longer safety certified (for using the Safe Torque Off in versions where included).
[199]	Injection Control	Indicates that the digital output is used for providing the injection on-off signal. A low voltage on the selected digital output indicates injection off, and high voltage indicates injection on.

The following options are related to the pack controller.

For wiring diagrams and settings for the meter, see *parameter group 25-** Pack Controller*.

[200]	Full Capacity	All pumps running at full speed.
[201]	Compressor 1 Running	One or more of the compressors controlled by the pack controller are running. The function also depends on <i>parameter 25-06 Number of Compressors</i> . If set to [0] No, compressor 1 refers to the compressor controlled by relay 1, and so on. If set to [1] Yes, compressor 1 refers to the compressor controlled by the frequency converter only (without any of the built-in relays involved), and compressor 2 to the compressor controlled by relay 1. See <i>Table 3.12</i> .
[202]	Compressor 2 Running	See [201] Compressor 1 Running.

[203]	Compressor 3 Running	See [201] Compressor 1 Running.
-------	----------------------	---------------------------------

Setting in parameter group 5-3* Digital Outputs	Setting in parameter 25-06 Number of Compressors	
	[0] No	7[1] Yes
[201] Compressor 1 Running	Controlled by relay 1	Frequency converter controlled
[202] Compressor 2 Running	Controlled by relay 2	Controlled by relay 1
[203] Compressor 3 Running	Controlled by relay 3	Controlled by relay 2

Table 3.12 Settings

5-30 Terminal 27 Digital Output

This parameter has the options described in *parameter group 5-3* Digital Outputs*.

5-31 Terminal 29 Digital Output

This parameter has the options described in *parameter group 5-3* Digital Outputs*.

5-32 Term X30/6 Digi Out (MCB 101)

This parameter is active when VLT® General Purpose I/O MCB 101 is mounted in the frequency converter. This parameter has the options described in *parameter group 5-3* Digital Outputs*.

5-33 Term X30/7 Digi Out (MCB 101)

This parameter is active when VLT® General Purpose I/O MCB 101 is mounted in the frequency converter. This parameter has the options described in *parameter group 5-3* Digital Outputs*.

3.7.4 5-4* Relays

Parameters for configuring the timing and the output functions for the relays.

5-40 Function Relay		
Array [8] (Relay 1 [0], Relay 2 [1]) VLT® Relay Card MCB 105: Relay 7 [6], Relay 8 [7] and Relay 9 [8]. Select options to define the function of the relays. The selection of each mechanical relay is realised in an array parameter.		
Option:	Function:	
[0]	No operation	
[1]	Control Ready	
[2]	Drive ready	
[3]	Drive rdy/rem ctrl	
[4]	Standby / no warning	
[5]	Running	Default setting for relay 2.
[6]	Running / no warning	
[8]	Run on ref/no warn	
[9]	Alarm	Default setting for relay 1.
[10]	Alarm or warning	
[11]	At torque limit	

5-40 Function Relay

Array [8]
(Relay 1 [0], Relay 2 [1])
VLT® Relay Card MCB 105: Relay 7 [6], Relay 8 [7] and Relay 9 [8].
Select options to define the function of the relays.
The selection of each mechanical relay is realised in an array parameter.

Option:	Function:	
[12]	Out of current range	
[13]	Below current, low	
[14]	Above current, high	
[15]	Out of speed range	
[16]	Below speed, low	
[17]	Above speed, high	
[18]	Out of feedb. range	
[19]	Below feedback, low	
[20]	Above feedback, high	
[21]	Thermal warning	
[25]	Reverse	
[26]	Bus OK	
[27]	Torque limit & stop	
[28]	Brake, no brake war	
[29]	Brake ready, no fault	
[30]	Brake fault (IGBT)	
[33]	Safe stop active	
[35]	External Interlock	
[36]	Control word bit 11	
[37]	Control word bit 12	
[40]	Out of ref range	
[41]	Below reference, low	
[42]	Above ref, high	
[44]	Oil boost active	
[45]	Bus ctrl.	
[46]	Bus ctrl, 1 if timeout	
[47]	Bus ctrl, 0 if timeout	
[60]	Comparator 0	
[61]	Comparator 1	
[62]	Comparator 2	
[63]	Comparator 3	
[64]	Comparator 4	
[65]	Comparator 5	
[70]	Logic rule 0	
[71]	Logic rule 1	

5-40 Function Relay		
Array [8] (Relay 1 [0], Relay 2 [1]) VLT® Relay Card MCB 105: Relay 7 [6], Relay 8 [7] and Relay 9 [8]). Select options to define the function of the relays. The selection of each mechanical relay is realised in an array parameter.		
Option:	Function:	
[72]	Logic rule 2	
[73]	Logic rule 3	
[74]	Logic rule 4	
[75]	Logic rule 5	
[80]	SL digital output A	
[81]	SL digital output B	
[82]	SL digital output C	
[83]	SL digital output D	
[84]	SL digital output E	
[85]	SL digital output F	
[160]	No alarm	
[161]	Running reverse	
[165]	Local ref active	
[166]	Remote ref active	
[167]	Start command activ	
[168]	Hand mode	
[169]	Auto mode	
[180]	Clock Fault	
[181]	Prev. Maintenance	
[183]	Pre/Post Lube	
[188]	AHF Capacitor Connect	
[190]	No-Flow	
[191]	Dry Pump	
[192]	End Of Curve	
[193]	Sleep Mode	
[194]	Broken Belt	
[195]	Bypass Valve Control	
[199]	Injection Control	
[211]	Pack Comp. 1	
[212]	Pack Comp. 2	
[213]	Pack Comp. 3	
[214]	Pack Comp. 4	
[215]	Pack Comp. 5	
[216]	Pack Comp. 6	
[217]	Pack Comp. 7	

5-41 On Delay, Relay		
Array [8]. (Relay 1 [0], Relay 2 [1], Relay 3 [2], Relay 4 [3], Relay 5 [4], Relay 6 [5], Relay 7 [6], Relay 8 [7], Relay 9 [8]).		
Range:	Function:	
0.01 s*	[0.01 - 600 s]	Enter the delay of the relay cut-in time. Select 1 of the available mechanical relays and VLT® Relay Card MCB 105 in an array function. See parameter 5-40 Function Relay.

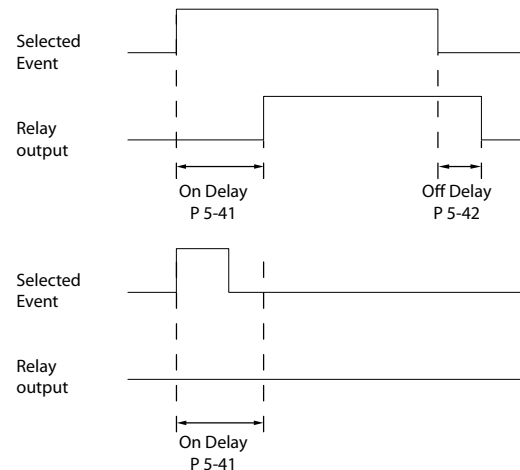

130BA171.10

Illustration 3.26 On Delay, Relay

5-42 Off Delay, Relay		
Array[20]		
Range:	Function:	
0.01 s*	[0.01 - 600 s]	Enter the delay of the relay cutout time. Select 1 of 2 internal mechanical relays in an array function. See parameter 5-40 Function Relay for details. If the selected event condition changes before a delay timer expires, the relay output is unaffected.

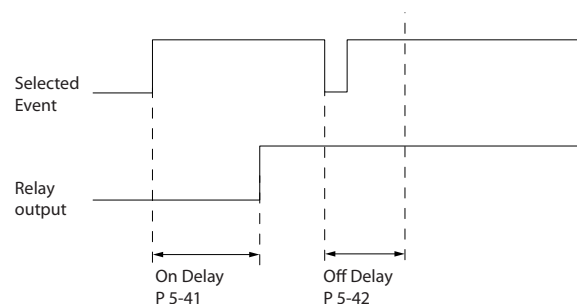

130BA172.10

Illustration 3.27 Off Delay, Relay

If the selected event condition changes before the on delay or off delay timer expires, the relay output is unaffected.

3.7.5 5-5* Pulse Input

The pulse input parameters are used to define an appropriate window for the impulse reference area by configuring the scaling and filter settings for the pulse inputs. Input terminal 29 or 33 acts as frequency reference inputs. Set terminal 29 (parameter 5-13 Terminal 29 Digital Input) or terminal 33 (parameter 5-15 Terminal 33 Digital Input) to [32] Pulse input. If terminal 29 is used as an input, set parameter 5-02 Terminal 29 Mode to [0] Input.

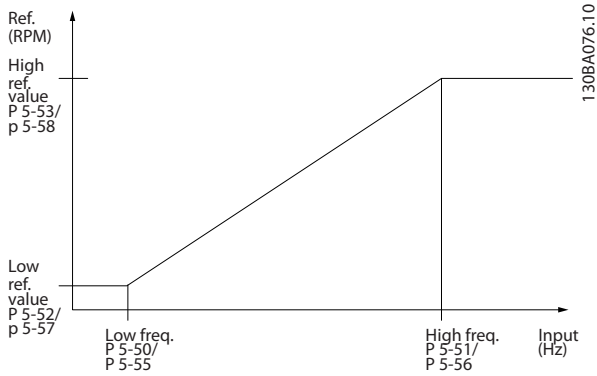

Illustration 3.28 Pulse Input

5-50 Term. 29 Low Frequency

Range:		Function:
100 Hz*	[0 - 110000 Hz]	Enter the low frequency limit corresponding to the low motor shaft speed (that is low reference value) in <i>parameter 5-52 Term. 29 Low Ref./Feedb. Value</i> . Refer to <i>Illustration 3.28</i> in this section.

5-51 Term. 29 High Frequency

Range:		Function:
100 Hz*	[0 - 110000 Hz]	Enter the high frequency limit corresponding to the high motor shaft speed (that is high reference value) in <i>parameter 5-53 Term. 29 High Ref./Feedb. Value</i> .

5-52 Term. 29 Low Ref./Feedb. Value

Range:		Function:
0*	[-999999.999 - 999999.999]	Enter the low reference value limit for the motor shaft speed [RPM]. This is also the lowest feedback value, see also <i>parameter 5-57 Term. 33 Low Ref./Feedb. Value</i> .

5-53 Term. 29 High Ref./Feedb. Value

Range:		Function:
100*	[-999999.999 - 999999.999]	Enter the high reference value [RPM] for the motor shaft speed and the high feedback value, see also <i>parameter 5-58 Term. 33 High Ref./Feedb. Value</i> .

5-54 Pulse Filter Time Constant #29

Range:		Function:
100 ms*	[1 - 1000 ms]	NOTICE This parameter cannot be adjusted while the motor is running.

5-54 Pulse Filter Time Constant #29

Range:		Function:
		Enter the pulse filter time constant. The pulse filter dampens oscillations of the feedback signal, which is an advantage if there is a lot of noise in the system. A high time constant value results in better dampening, but also increases the time delay through the filter.

5-55 Term. 33 Low Frequency

Range:		Function:
100 Hz*	[0 - 110000 Hz]	Enter the low frequency corresponding to the low motor shaft speed (that is low reference value) in <i>parameter 5-57 Term. 33 Low Ref./Feedb. Value</i> .

5-56 Term. 33 High Frequency

Range:		Function:
100 Hz*	[0 - 110000 Hz]	Enter the high frequency corresponding to the high motor shaft speed (that is high reference value) in <i>parameter 5-58 Term. 33 High Ref./Feedb. Value</i> .

5-57 Term. 33 Low Ref./Feedb. Value

Range:		Function:
0*	[-999999.999 - 999999.999]	Enter the low reference value [RPM] for the motor shaft speed. This is also the low feedback value, see also <i>parameter 5-52 Term. 29 Low Ref./Feedb. Value</i> .

5-58 Term. 33 High Ref./Feedb. Value

Range:		Function:
100*	[-999999.999 - 999999.999]	Enter the high reference value [RPM] for the motor shaft speed. See also <i>parameter 5-53 Term. 29 High Ref./Feedb. Value</i> .

5-59 Pulse Filter Time Constant #33

Range:		Function:
100 ms*	[1 - 1000 ms]	NOTICE This parameter cannot be adjusted while the motor is running. Enter the pulse filter time constant. The low-pass filter reduces the influence, and dampens oscillations on the feedback signal from the control. This is an advantage if there is a great amount of noise in the system.

3.7.6 5-6* Pulse Outputs

Parameters for configuring the scaling and output functions of pulse outputs. The pulse outputs are designated to terminals 27 or 29. Select terminal 27 output in *parameter 5-01 Terminal 27 Mode* and terminal 29 output in *parameter 5-02 Terminal 29 Mode*.

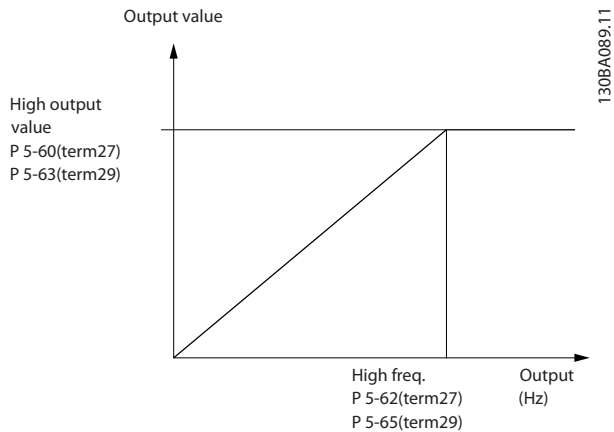

Illustration 3.29 Pulse Output

5-60 Terminal 27 Pulse Output Variable		
Select the operation variable assigned for terminal 27 readouts. This parameter has the same options as <i>parameter group 5-6* Pulse Output</i> .		
Option:	Function:	
	NOTICE This parameter cannot be adjusted while the motor is running.	
[0] *	No operation	
[45]	Bus ctrl.	
[48]	Bus ctrl., timeout	
[100]	Output frequency	
[101]	Reference	
[102]	Feedback	
[103]	Motor Current	
[104]	Torque rel to limit	
[105]	Torq relate to rated	
[106]	Power	
[107]	Speed	
[108]	Torque	
[109]	Max Out Freq	
[113]	Ext. Closed Loop 1	
[114]	Ext. Closed Loop 2	
[115]	Ext. Closed Loop 3	

5-62 Pulse Output Max Freq #27		
Range:	Function:	
	NOTICE This parameter cannot be adjusted while the motor is running.	
5000 Hz*	[0 - 32000 Hz]	Set the maximum frequency for terminal 27 corresponding to the output variable selected in <i>parameter 5-60 Terminal 27 Pulse Output Variable</i> .

5-63 Terminal 29 Pulse Output Variable		
Option:	Function:	
	NOTICE This parameter cannot be adjusted while the motor is running.	
	Select the variable for viewing on terminal 29. Same options and functions as <i>parameter group 5-6* Pulse Output</i> .	
[0] *	No operation	
[45]	Bus ctrl.	
[48]	Bus ctrl., timeout	
[100]	Output frequency	
[101]	Reference	
[102]	Feedback	
[103]	Motor Current	
[104]	Torque rel to limit	
[105]	Torq relate to rated	
[106]	Power	
[107]	Speed	
[108]	Torque	
[109]	Max Out Freq	
[113]	Ext. Closed Loop 1	
[114]	Ext. Closed Loop 2	
[115]	Ext. Closed Loop 3	

5-65 Pulse Output Max Freq #29		
Range:	Function:	
5000 Hz*	[0 - 32000 Hz]	Set the maximum frequency for terminal 29 corresponding to the output variable set in <i>parameter 5-63 Terminal 29 Pulse Output Variable</i> .

5-66 Terminal X30/6 Pulse Output Variable		
Select the variable for readout on terminal X30/6. This parameter is active when VLT® General Purpose I/O MCB 101 is installed in the frequency converter. Same options and functions as <i>parameter group 5-6* Pulse Outputs</i> .		
Option:	Function:	
[0] *	No operation	

5-66 Terminal X30/6 Pulse Output Variable		
Select the variable for readout on terminal X30/6.		
This parameter is active when VLT® General Purpose I/O MCB 101 is installed in the frequency converter.		
Same options and functions as <i>parameter group 5-6* Pulse Outputs</i> .		
Option:	Function:	
[45]	Bus ctrl.	
[48]	Bus ctrl., timeout	
[100]	Output frequency	
[101]	Reference	
[102]	Feedback	
[103]	Motor Current	
[104]	Torque rel to limit	
[105]	Torq relate to rated	
[106]	Power	
[107]	Speed	
[108]	Torque	
[109]	Max Out Freq	
[113]	Ext. Closed Loop 1	
[114]	Ext. Closed Loop 2	
[115]	Ext. Closed Loop 3	

5-68 Pulse Output Max Freq #X30/6		
Range:	Function:	
5000 Hz*	[0 - 32000 Hz]	<p>NOTICE</p> <p>This parameter cannot be adjusted while the motor is running.</p> <p>Select the maximum frequency on terminal X30/6 referring to the output variable in <i>parameter 5-66 Terminal X30/6 Pulse Output Variable</i>.</p> <p>This parameter is active when VLT® General Purpose I/O MCB 101 is installed in the frequency converter.</p>

3.7.7 5-8* I/O Options

5-80 AHF Cap Reconnect Delay		
Range:	Function:	
25 s*	[1 - 120 s]	Guarantees a minimum off-time for the capacitors. The timer starts once the AHF capacitor disconnects and has to expire before the output is allowed to be on again. It only turns on again if the frequency converter power is 20–30%.

3.7.8 5-9* Bus-Controlled

This parameter group selects digital and relay outputs via a fieldbus setting.

5-90 Digital & Relay Bus Control																																								
Range:	Function:																																							
0* [0 - 2147483647]	<p>This parameter holds the state of the digital outputs and relays that are controlled by bus.</p> <p>A logical 1 indicates that the output is high or active.</p> <p>A logical 0 indicates that the output is low or inactive.</p> <table border="1"> <tr><td>Bit 0</td><td>CC digital output, terminal 27</td></tr> <tr><td>Bit 1</td><td>CC digital output, terminal 29</td></tr> <tr><td>Bit 2</td><td>GPIO digital output, terminal X 30/6</td></tr> <tr><td>Bit 3</td><td>GPIO digital output, terminal X 30/7</td></tr> <tr><td>Bit 4</td><td>CC relay 1 output terminal</td></tr> <tr><td>Bit 5</td><td>CC relay 2 output terminal</td></tr> <tr><td>Bit 6</td><td>Option B relay 1 output terminal</td></tr> <tr><td>Bit 7</td><td>Option B relay 2 output terminal</td></tr> <tr><td>Bit 8</td><td>Option B relay 3 output terminal</td></tr> <tr><td>Bit 9–15</td><td>Reserved for future terminals</td></tr> <tr><td>Bit 16</td><td>Option C relay 1 output terminal</td></tr> <tr><td>Bit 17</td><td>Option C relay 2 output terminal</td></tr> <tr><td>Bit 18</td><td>Option C relay 3 output terminal</td></tr> <tr><td>Bit 19</td><td>Option C relay 4 output terminal</td></tr> <tr><td>Bit 20</td><td>Option C relay 5 output terminal</td></tr> <tr><td>Bit 21</td><td>Option C relay 6 output terminal</td></tr> <tr><td>Bit 22</td><td>Option C relay 7 output terminal</td></tr> <tr><td>Bit 23</td><td>Option C relay 8 output terminal</td></tr> <tr><td>Bit 24–31</td><td>Reserved for future terminals</td></tr> </table>		Bit 0	CC digital output, terminal 27	Bit 1	CC digital output, terminal 29	Bit 2	GPIO digital output, terminal X 30/6	Bit 3	GPIO digital output, terminal X 30/7	Bit 4	CC relay 1 output terminal	Bit 5	CC relay 2 output terminal	Bit 6	Option B relay 1 output terminal	Bit 7	Option B relay 2 output terminal	Bit 8	Option B relay 3 output terminal	Bit 9–15	Reserved for future terminals	Bit 16	Option C relay 1 output terminal	Bit 17	Option C relay 2 output terminal	Bit 18	Option C relay 3 output terminal	Bit 19	Option C relay 4 output terminal	Bit 20	Option C relay 5 output terminal	Bit 21	Option C relay 6 output terminal	Bit 22	Option C relay 7 output terminal	Bit 23	Option C relay 8 output terminal	Bit 24–31	Reserved for future terminals
Bit 0	CC digital output, terminal 27																																							
Bit 1	CC digital output, terminal 29																																							
Bit 2	GPIO digital output, terminal X 30/6																																							
Bit 3	GPIO digital output, terminal X 30/7																																							
Bit 4	CC relay 1 output terminal																																							
Bit 5	CC relay 2 output terminal																																							
Bit 6	Option B relay 1 output terminal																																							
Bit 7	Option B relay 2 output terminal																																							
Bit 8	Option B relay 3 output terminal																																							
Bit 9–15	Reserved for future terminals																																							
Bit 16	Option C relay 1 output terminal																																							
Bit 17	Option C relay 2 output terminal																																							
Bit 18	Option C relay 3 output terminal																																							
Bit 19	Option C relay 4 output terminal																																							
Bit 20	Option C relay 5 output terminal																																							
Bit 21	Option C relay 6 output terminal																																							
Bit 22	Option C relay 7 output terminal																																							
Bit 23	Option C relay 8 output terminal																																							
Bit 24–31	Reserved for future terminals																																							
Table 3.13 Digital Output Bits																																								

5-93 Pulse Out #27 Bus Control		
Range:	Function:	
0 %*	[0 - 100 %]	Contains the frequency to apply to the digital output terminal 27 when it is configured as bus-controlled.

5-94 Pulse Out #27 Timeout Preset		
Range:	Function:	
0 %*	[0 - 100 %]	Contains the frequency to apply to the digital output terminal 27 when it is configured as bus-controlled timeout, and timeout is detected.

5-95 Pulse Out #29 Bus Control		
Range:	Function:	
0 %*	[0 - 100 %]	Contains the frequency to apply to the digital output terminal 29 when it is configured as bus-controlled.

5-96 Pulse Out #29 Timeout Preset		
Range:	Function:	
0 %*	[0 - 100 %]	Contains the frequency to apply to the digital output terminal 29 when it is configured as bus-controlled timeout, and timeout is detected.

5-97 Pulse Out #X30/6 Bus Control		
Range:	Function:	
0 %*	[0 - 100 %]	Contains the frequency to apply to the digital output terminal 27 when it is configured as bus-controlled.

5-98 Pulse Out #X30/6 Timeout Preset		
Range:	Function:	
0 %*	[0 - 100 %]	Contains the frequency to apply to the digital output terminal 6 when it is configured as bus-controlled timeout, and timeout is detected.

3.8 Parameters: 6-** Analog In/Out

3.8.1 6-** Analog In/Out

Parameter group for configuration of the analog input and output.

3.8.2 6-0* Analog I/O Mode

Parameter group for setting up the analog I/O configuration.

The frequency converter is equipped with 2 analog inputs:

- Terminals 53
- Terminals 54

The analog inputs can be allocated freely to either voltage (0–10 V) or current input (0/4–20 mA).

NOTICE

Thermistors may be connected to either an analog or a digital input.

6-00 Live Zero Timeout Time		
Range:	Function:	
10 s* [1 - 99 s]	Enter the live zero timeout in s. Live zero timeout time is active for analog inputs, that is, terminal 53 or terminal 54, used as reference or feedback sources. If the reference signal value associated with the selected current input drops below 50% of the value set in: <ul style="list-style-type: none"> • Parameter 6-10 Terminal 53 Low Voltage. • Parameter 6-12 Terminal 53 Low Current. • Parameter 6-20 Terminal 54 Low Voltage. • Parameter 6-22 Terminal 54 Low Current. For a time period longer than the time set in parameter 6-00 Live Zero Timeout Time, the function selected in parameter 6-01 Live Zero Timeout Function is activated.	

6-01 Live Zero Timeout Function		
Option:	Function:	
	Select the timeout function. The function set in parameter 6-01 Live Zero Timeout Function is activated if the input signal on terminal 53 or 54 is below 50% of the value in: <ul style="list-style-type: none"> • Parameter 6-10 Terminal 53 Low Voltage. • Parameter 6-12 Terminal 53 Low Current. • Parameter 6-20 Terminal 54 Low Voltage. 	

6-01 Live Zero Timeout Function		
Option:	Function:	
	<ul style="list-style-type: none"> • Parameter 6-22 Terminal 54 Low Current. The function can also be activated for a time period defined in parameter 6-00 Live Zero Timeout Time. If several timeouts occur simultaneously, the frequency converter prioritizes the timeout functions as follows: <ol style="list-style-type: none"> 1. Parameter 6-01 Live Zero Timeout Function. 2. Parameter 8-04 Control Timeout Function. 	
[0] *	Off	
[1]	Freeze output	Frozen at the present value. Live zero timeout time does not apply to freeze output.
[2]	Stop	Overruled to stop.
[3]	Jogging	Overruled to jog speed.
[4]	Max. speed	Overruled to maximum speed.
[5]	Stop and trip	Overruled to stop with subsequent trip.
[21]	Min. Reference	
[22]	Max. Reference	

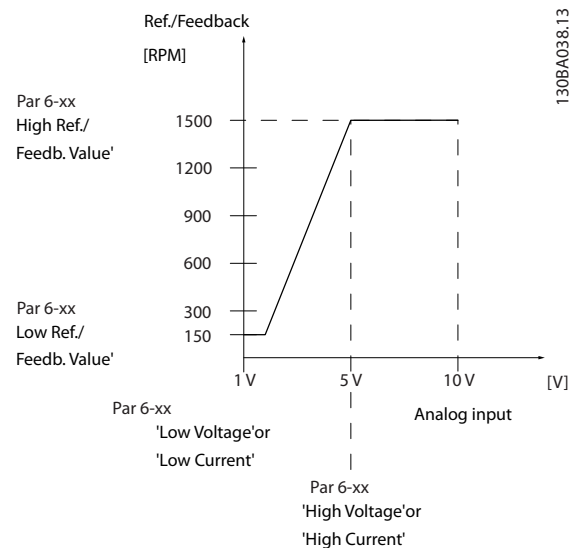

Illustration 3.30 Live Zero Conditions

3.8.3 6-1* Analog Input 1

Parameters for configuring the scaling and limits for analog input 1 (terminal 53).

6-10 Terminal 53 Low Voltage		
Range:	Function:	
0.07 V* [0 - par. 6-11 V]	NOTICE For the live zero alarms to work, <i>parameter 6-10 Terminal 53 Low Voltage</i> must have a value of 1 V or greater. Enter the low voltage value. This analog input scaling value should correspond to the low reference feedback value set in <i>parameter 6-14 Terminal 53 Low Ref./Feedb. Value</i> .	

6-11 Terminal 53 High Voltage		
Range:	Function:	
10 V* [par. 6-10 - 10 V]	Enter the high voltage value. This analog input scaling value should correspond to the high reference feedback value set in <i>parameter 6-15 Terminal 53 High Ref./Feedb. Value</i> .	

6-12 Terminal 53 Low Current		
Range:	Function:	
4 mA* [0 - par. 6-13 mA]	Enter the low current value. This reference signal should correspond to the low reference feedback value, set in <i>parameter 6-14 Terminal 53 Low Ref./Feedb. Value</i> . Set the value at >2 mA to activate the live zero timeout function in <i>parameter 6-01 Live Zero Timeout Function</i> .	

6-13 Terminal 53 High Current		
Range:	Function:	
20 mA* [par. 6-12 - 20 mA]	Enter the high current value corresponding to the high reference/feedback set in <i>parameter 6-15 Terminal 53 High Ref./Feedb. Value</i> .	

6-14 Terminal 53 Low Ref./Feedb. Value		
Range:	Function:	
0* [-999999.999 - 999999.999]	Enter the analog input scaling value that corresponds to the low voltage/low current set in <i>parameter 6-10 Terminal 53 Low Voltage</i> and <i>parameter 6-12 Terminal 53 Low Current</i> .	

6-15 Terminal 53 High Ref./Feedb. Value		
Range:	Function:	
Size related*	[-999999.999 - 999999.999]	Enter the analog input scaling value that corresponds to the high

6-15 Terminal 53 High Ref./Feedb. Value		
Range:	Function:	
		voltage/high current value set in <i>parameter 6-11 Terminal 53 High Voltage</i> and <i>parameter 6-13 Terminal 53 High Current</i> .

6-16 Terminal 53 Filter Time Constant		
Range:	Function:	
0.001 s* [0.001 - 10 s]	NOTICE This parameter cannot be adjusted while the motor is running. Enter the filter time constant. This constant is a first-order digital low-pass filter time for suppressing electrical noise in terminal 53. A high value improves dampening, but also increases the delay through the filter.	

6-17 Terminal 53 Live Zero		
Option:	Function:	
[0]	Disabled	Disables the live zero monitoring, for example if the analog outputs are used as part of a decentral I/O system (that is if these are used to feed a building management system with data, and not as part of any control functions related to the frequency converter).
[1] *	Enabled	

3.8.4 6-2* Analog Input 2

Parameters for configuring the scaling and limits for analog input 2 (terminal 54).

6-20 Terminal 54 Low Voltage		
Range:	Function:	
0.07 V* [0 - par. 6-21 V]	Enter the low voltage value. This analog input scaling value should correspond to the low reference feedback value set in <i>parameter 6-24 Terminal 54 Low Ref./Feedb. Value</i> .	

6-21 Terminal 54 High Voltage		
Range:	Function:	
10 V* [par. 6-20 - 10 V]	Enter the high voltage value. This analog input scaling value should correspond to the high reference feedback value set in <i>parameter 6-25 Terminal 54 High Ref./Feedb. Value</i> .	

6-22 Terminal 54 Low Current		
Range:	Function:	
4 mA* [0 - par. 6-23 mA]	Enter the low current value. This reference signal should correspond to the low reference feedback value, set in <i>parameter 6-24 Terminal 54 Low Ref./Feedb. Value</i> . Set the value at >2 mA to activate the live zero timeout function in <i>parameter 6-01 Live Zero Timeout Function</i> .	

6-23 Terminal 54 High Current		
Range:	Function:	
20 mA* [par. 6-22 - 20 mA]	Enter the high current value corresponding to the high reference feedback value set in <i>parameter 6-25 Terminal 54 High Ref./Feedb. Value</i> .	

6-24 Terminal 54 Low Ref./Feedb. Value		
Range:	Function:	
-1* [-999999.999 - 999999.999]	Enter the analog input scaling value that corresponds to the low voltage/low current value set in <i>parameter 6-20 Terminal 54 Low Voltage</i> and <i>parameter 6-22 Terminal 54 Low Current</i> .	

6-25 Terminal 54 High Ref./Feedb. Value		
Range:	Function:	
Size related* [-999999.999 - 999999.999]	Enter the analog input scaling value that corresponds to the high voltage/high current value set in <i>parameter 6-21 Terminal 54 High Voltage</i> and <i>parameter 6-23 Terminal 54 High Current</i> .	

6-26 Terminal 54 Filter Time Constant		
Range:	Function:	
0.001 s* [0.001 - 10 s]	<p>NOTICE This parameter cannot be adjusted while the motor is running.</p> <p>Enter the filter time constant. This is a first-order digital low-pass filter time constant for suppressing electrical noise in terminal 54. Increasing the value improves dampening but also increases the time delay through the filter.</p>	

6-27 Terminal 54 Live Zero		
Option:	Function:	
	Disables the live zero-monitoring, for example if the analog outputs are used as part of a decentral I/O system (that is if these are used to feed a building management system with data,	

6-27 Terminal 54 Live Zero		
Option:	Function:	
	and not as part of any control functions related to the frequency converter).	
[0]	Disabled	
[1] *	Enabled	

3.8.5 6-3* Analog Input 3 General Purpose I/O MCB 101

Parameter group for configuring the scale and limits for analog input 3 (X30/11) in VLT® General Purpose I/OMCB 101.

6-30 Terminal X30/11 Low Voltage		
Range:	Function:	
0.07 V* [0 - par. 6-31 V]	Sets the analog input scaling value to correspond to the low reference feedback value (set in <i>parameter 6-34 Term. X30/11 Low Ref./Feedb. Value</i>).	

6-31 Terminal X30/11 High Voltage		
Range:	Function:	
10 V* [par. 6-30 - 10 V]	Sets the analog input scaling value to correspond to the high reference feedback value (set in <i>parameter 6-35 Term. X30/11 High Ref./Feedb. Value</i>).	

6-34 Term. X30/11 Low Ref./Feedb. Value		
Range:	Function:	
0* [-999999.999 - 999999.999]	Sets the analog input scaling value to correspond to the low voltage value (set in <i>parameter 6-30 Terminal X30/11 Low Voltage</i>).	

6-35 Term. X30/11 High Ref./Feedb. Value		
Range:	Function:	
100* [-999999.999 - 999999.999]	Sets the analog input scaling value to correspond to the high-voltage value (set in <i>parameter 6-31 Terminal X30/11 High Voltage</i>).	

6-36 Term. X30/11 Filter Time Constant		
Range:	Function:	
0.001 s* [0.001 - 10 s]	<p>NOTICE This parameter cannot be adjusted while the motor is running.</p> <p>Enter the filter time constant. This constant is a first-order digital low-pass filter time for suppressing electrical noise in terminal X30/11. A high value improves dampening, but also increases the delay through the filter.</p>	

6-37 Term. X30/11 Live Zero		
Option:	Function:	
		This parameter makes it possible to disable the live zero-monitoring. For example, to be used if the analog outputs are used in a decentral I/O system (when an analog output does not fulfil any control function, but feeds a data storage device).
[0]	Disabled	
[1] *	Enabled	

3.8.6 6-4* Analog Input X30/12

Parameter group for configuring the scale and limits for analog input 4 (X30/12) placed on VLT® General Purpose I/O MCB 101.

6-40 Terminal X30/12 Low Voltage		
Range:	Function:	
0.07 V*	[0 - par. 6-41 V]	Sets the analog input scaling value to correspond to the low reference feedback value set in <i>parameter 6-44 Term. X30/12 Low Ref./Feedb. Value</i> .

6-41 Terminal X30/12 High Voltage		
Range:	Function:	
10 V*	[par. 6-40 - 10 V]	Sets the analog input scaling value to correspond to the high reference feedback value set in <i>parameter 6-45 Term. X30/12 High Ref./Feedb. Value</i> .

6-44 Term. X30/12 Low Ref./Feedb. Value		
Range:	Function:	
0*	[-999999.999 - 999999.999]	Sets the analog output scaling value to correspond to the low voltage value set in <i>parameter 6-40 Terminal X30/12 Low Voltage</i> .

6-45 Term. X30/12 High Ref./Feedb. Value		
Range:	Function:	
100*	[-999999.999 - 999999.999]	Sets the analog input scaling value to correspond to the high voltage value set in <i>parameter 6-41 Terminal X30/12 High Voltage</i> .

6-46 Term. X30/12 Filter Time Constant		
Range:	Function:	
0.001 s*	[0.001 - 10 s]	NOTICE This parameter cannot be adjusted while the motor is running. Enter the filter time constant. This constant is a first-order digital low-pass filter time for suppressing electrical noise

6-46 Term. X30/12 Filter Time Constant		
Range:	Function:	
		in terminal X30/12. A high value improves dampening, but also increases the delay through the filter.

6-47 Term. X30/12 Live Zero		
Option:	Function:	
		This parameter makes it possible to disable the live zero-monitoring. For example, to be used if the analog outputs are used in a decentral I/O system (when an analog output does not fulfil any control function, but feeds a data storage device).
[0]	Disabled	
[1] *	Enabled	

3.8.7 6-5* Analog Output 1

Parameters for configuring the scaling and limits for analog output 1, that is terminal 42. Analog outputs are current outputs: 0/4–20 mA. Common terminal (terminal 39) is the same terminal and has the same electrical potential for analog common and digital common connection. Resolution on analog output is 12 bit.

6-50 Terminal 42 Output		
Option:	Function:	
		NOTICE Values for setting the minimum reference in open loop are in <i>parameter 3-02 Minimum Reference</i> . Values for the maximum reference for open loop are in <i>parameter 3-03 Maximum Reference</i> . This parameter enables the function of terminal 42 as an analog current output. Depending on the option selected, the output is either 0–20 mA or 4–20 mA. The current value can be read out in the LCP in <i>parameter 16-65 Analog Output 42 [mA]</i> .
[0]	No operation	
[100] *	Output frequency	0–100 Hz, (0–20 mA).
[101]	Reference	Minimum reference–Maximum reference, (0–20 mA).
[102]	Feedback	
[103]	Motor Current	0–Inverter maximum current (<i>parameter 16-37 Inv. Max. Current</i>), (0–20 mA).

6-50 Terminal 42 Output		
Option:	Function:	
[104]	Torque rel to limit	0-Torque limit (<i>parameter 4-16 Torque Limit Motor Mode</i>), (0-20 mA).
[105]	Torq relate to rated	0-Motor rated torque, (0-20 mA).
[106]	Power	0-Motor rated power, (0-20 mA).
[107]	Speed	0-Speed high limit (<i>parameter 4-13 Motor Speed High Limit [RPM]</i> and <i>parameter 4-14 Motor Speed High Limit [Hz]</i>), (0-20 mA).
[108]	Torque	
[109]	Max Out Freq	
[113]	Ext. Closed Loop 1	0-100%, (0-20 mA).
[114]	Ext. Closed Loop 2	0-100%, (0-20 mA).
[115]	Ext. Closed Loop 3	0-100%, (0-20 mA).
[121]	Air pres. to Flow	
[122]	Air pres. to Flow 4-20mA	
[130]	Output freq. 4-20mA	0-100 Hz.
[131]	Reference 4-20mA	Minimum reference-Maximum reference.
[132]	Feedback 4-20mA	-200% to +200% of <i>parameter 20-14 Maximum Reference/Feedb.</i>
[133]	Motor cur. 4-20mA	0-Inverter maximum current (<i>parameter 16-37 Inv. Max. Current</i>).
[134]	Torq.% lim 4-20 mA	0-Torque limit (<i>parameter 4-16 Torque Limit Motor Mode</i>).
[135]	Torq.% nom 4-20mA	0-Motor rated torque.
[136]	Power 4-20mA	0-Motor rated power.
[137]	Speed 4-20mA	0-Speed high limit (<i>parameter 4-13 Motor Speed High Limit [RPM]</i> and <i>parameter 4-14 Motor Speed High Limit [Hz]</i>).
[138]	Torque 4-20mA	
[139]	Bus ctrl.	0-100%, (0-20 mA).
[140]	Bus ctrl. 4-20 mA	0-100%.
[141]	Bus ctrl t.o.	0-100%, (0-20 mA).
[142]	Bus ctrl t.o. 4-20mA	0-100%.
[143]	Ext. CL 1 4-20mA	0-100%.
[144]	Ext. CL 2 4-20mA	0-100%.

6-50 Terminal 42 Output		
Option:	Function:	
[145]	Ext. CL 3 4-20mA	0-100%.
[150]	Max Out Fr 4-20 mA	
[184]	Mirror AI53 mA	
[185]	Mirror AI54 mA	

6-51 Terminal 42 Output Min Scale		
Range:	Function:	
0 %* [0 - 200 %]	Scale for the minimum output (0 mA or 4 mA) of the analog signal at terminal 42. Set the value to be the percentage of the full range of the variable selected in <i>parameter 6-50 Terminal 42 Output</i> .	

6-52 Terminal 42 Output Max Scale		
Range:	Function:	
100 %* [0 - 200 %]	Scale for the maximum output (20 mA) of the analog signal at terminal 42. Set the value to be the percentage of the full range of the variable selected in <i>parameter 6-50 Terminal 42 Output</i> .	
<p>Illustration 3.31 Output Current vs Reference Variable</p>		
<p>It is possible to obtain a value lower than 20 mA at full scale by programming values >100% by using a formula as follows:</p> $20 \text{ mA} / \text{desired maximum current} \times 100 \%$ <p>i.e. $10 \text{ mA} : \frac{20 \text{ mA}}{10 \text{ mA}} \times 100 \% = 200 \%$</p>		

Example 1:
 Variable value = output frequency, range = 0-100 Hz.
 Range needed for output = 0-50 Hz.
 Output signal 0 mA or 4 mA is needed at 0 Hz (0% of range). Set *parameter 6-51 Terminal 42 Output Min Scale* to 0%.
 Output signal 20 mA is needed at 50 Hz (50% of range). Set *parameter 6-52 Terminal 42 Output Max Scale* to 50%.

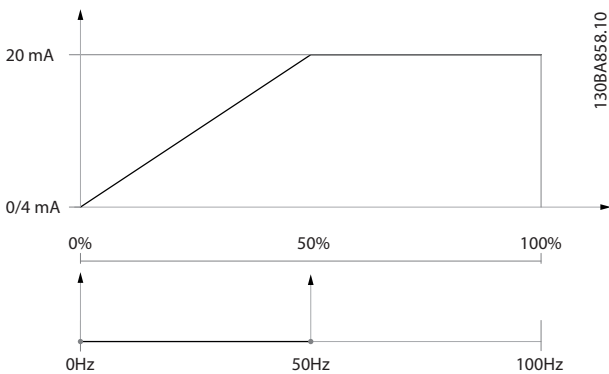

Illustration 3.32 Example 1

Example 2:

Variable = feedback, range = -200% to +200%.
 Range needed for output = 0–100%.
 Output signal 0 mA or 4 mA is needed at 0% (50% of range). Set *parameter 6-51 Terminal 42 Output Min Scale* to 50%.
 Output signal 20 mA is needed at 100% (75% of range). Set *parameter 6-52 Terminal 42 Output Max Scale* to 75%.

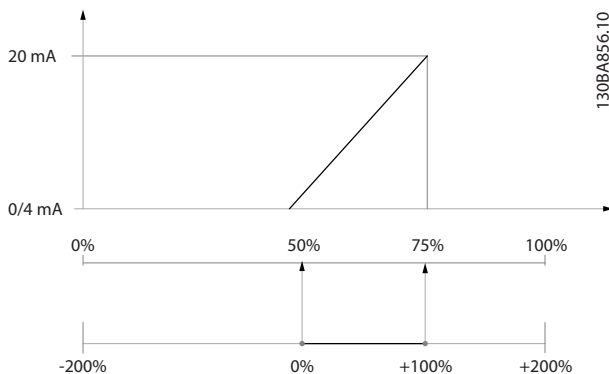

Illustration 3.33 Example 2

Example 3:

Variable value = reference, range = minimum reference–maximum reference
 Range needed for output = minimum reference (0%)–maximum reference (100%), 0–10 mA.
 Output signal 0 mA or 4 mA is needed at minimum reference. Set *parameter 6-51 Terminal 42 Output Min Scale* to 0%.
 Output signal 10 mA is needed at maximum reference (100% of range). Set *parameter 6-52 Terminal 42 Output Max Scale* to 200%.
 (20 mA/10 mA x 100%=200%).

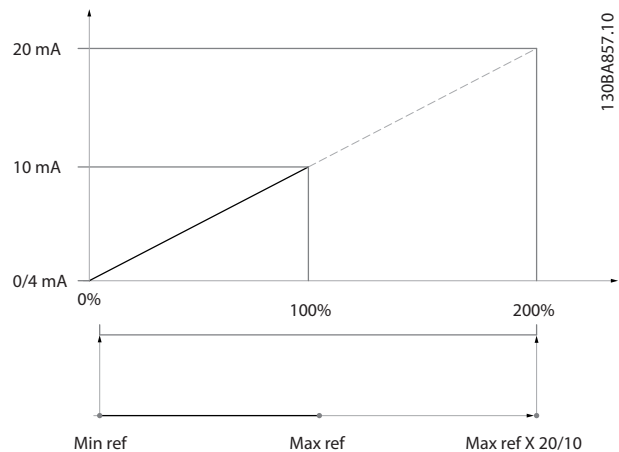

Illustration 3.34 Example 3

6-53 Terminal 42 Output Bus Control		
Range:	Function:	
0 %*	[0 - 100 %]	Holds the level of output 42 if controlled by bus.

6-54 Terminal 42 Output Timeout Preset		
Range:	Function:	
0 %*	[0 - 100 %]	Holds the preset level of output 42. If a timeout function is selected in <i>parameter 6-50 Terminal 42 Output</i> , the output is preset to this level if a fieldbus timeout occurs.

3.8.8 6-6* Analog Output 2 MCB 101

Analog outputs are current outputs: 0/4–20 mA. Common terminal (terminal X30/8) is the same terminal and electrical potential for analog common connection. Resolution on analog output is 12 bit.

6-60 Terminal X30/8 Output

Same options and functions as *parameter 6-50 Terminal 42 Output*.

6-61 Terminal X30/8 Min. Scale

Range:	Function:	
0 %*	[0 - 200 %]	Scales the minimum output of the selected analog signal on terminal X30/8. Scale the minimum value as a percentage of the maximum signal value, that is 0 mA (or 0 Hz) is required at 25% of the maximum output value and 25% is programmed. The value can never exceed the corresponding setting in <i>parameter 6-62 Terminal X30/8 Max. Scale</i> if the value is below 100%. This parameter is active when VLT® General Purpose I/O MCB 101 is mounted in the frequency converter.

6-62 Terminal X30/8 Max. Scale		
Range:	Function:	
100 %*	[0 - 200 %]	<p>Scales the maximum output of the selected analog signal on terminal X30/8. Scale the value to the required maximum value of the current signal output. Scale the output to give a lower current than 20 mA at full scale, or 20 mA at an output below 100% of the maximum signal value. If 20 mA is the required output current at a value between 0–100% of the full-scale output, program the percentage value in the parameter, that is 50%=20 mA. If a current 4–20 mA is required at maximum output (100%), calculate the percentage value as follows:</p> $20 \text{ mA} / \text{desired maximum current} \times 100\%$ <p>i.e. 10 mA: $\frac{20 \text{ mA}}{10 \text{ mA}} \times 100\% = 200\%$</p>

6-63 Terminal X30/8 Output Bus Control		
Range:	Function:	
0 %*	[0 - 100 %]	Contains the value to apply to the output terminal when it is configured as bus-controlled.

6-64 Terminal X30/8 Output Timeout Preset		
Range:	Function:	
0 %*	[0 - 100 %]	Contains the value to apply to the output terminal, when it is configured as bus-controlled timeout and timeout is detected.

6-70 Terminal X45/1 Output		
Select the output of terminal X45/1 of VLT® Extended Relay Card MCB 113.		
Option:	Function:	
[0] *	No operation	
[100]	Output frequency	
[101]	Reference	
[102]	Feedback	
[103]	Motor Current	
[104]	Torque rel to limit	
[105]	Torq relate to rated	
[106]	Power	
[107]	Speed	
[108]	Torque	
[109]	Max Out Freq	
[113]	Ext. Closed Loop 1	
[114]	Ext. Closed Loop 2	
[115]	Ext. Closed Loop 3	
[121]	Air pres. to Flow	
[122]	Air pres. to Flow 4-20mA	
[130]	Output freq. 4-20mA	
[131]	Reference 4-20mA	
[132]	Feedback 4-20mA	
[133]	Motor cur. 4-20mA	
[134]	Torq.% lim 4-20 mA	

6-70 Terminal X45/1 Output		
Select the output of terminal X45/1 of VLT® Extended Relay Card MCB 113.		
Option:	Function:	
[135]	Torq.% nom 4-20mA	
[136]	Power 4-20mA	
[137]	Speed 4-20mA	
[138]	Torque 4-20mA	
[139]	Bus ctrl.	
[140]	Bus ctrl. 4-20 mA	
[141]	Bus ctrl t.o.	
[142]	Bus ctrl t.o. 4-20mA	
[143]	Ext. CL 1 4-20mA	
[144]	Ext. CL 2 4-20mA	
[145]	Ext. CL 3 4-20mA	
[150]	Max Out Fr 4-20 mA	
[184]	Mirror AI53 mA	
[185]	Mirror AI54 mA	

6-71 Terminal X45/1 Min. Scale		
Enter the minimum scaling value of output of the analog signal on terminal X45/1.		
Range:	Function:	
0 %*	[0 - 200 %]	

6-72 Terminal X45/1 Max. Scale		
Enter the maximum scaling value of output of the analog signal on terminal X45/1.		
Range:	Function:	
100 %*	[0 - 200 %]	

6-73 Terminal X45/1 Bus Control		
Enter the output value for terminal X45/1 when the fieldbus controls the terminal.		
Range:	Function:	
0 %*	[0 - 100 %]	

6-74 Terminal X45/1 Output Timeout Preset		
Enter the output value for terminal X45/1 when the bus control timeout for the terminal is detected.		
Range:	Function:	
0 %*	[0 - 100 %]	

6-80 Terminal X45/3 Output		
Select the output of terminal X45/3 of VLT® Extended Relay Card MCB 113.		
Option:	Function:	
[0] *	No operation	
[100]	Output frequency	
[101]	Reference	
[102]	Feedback	
[103]	Motor Current	
[104]	Torque rel to limit	
[105]	Torq relate to rated	

6-80 Terminal X45/3 Output		
Select the output of terminal X45/3 of VLT® Extended Relay Card MCB 113.		
Option:		Function:
[106]	Power	
[107]	Speed	
[108]	Torque	
[109]	Max Out Freq	
[113]	Ext. Closed Loop 1	
[114]	Ext. Closed Loop 2	
[115]	Ext. Closed Loop 3	
[121]	Air pres. to Flow	
[122]	Air pres. to Flow 4-20mA	
[130]	Output freq. 4-20mA	
[131]	Reference 4-20mA	
[132]	Feedback 4-20mA	
[133]	Motor cur. 4-20mA	
[134]	Torq.% lim 4-20 mA	
[135]	Torq.% nom 4-20mA	
[136]	Power 4-20mA	
[137]	Speed 4-20mA	
[138]	Torque 4-20mA	
[139]	Bus ctrl.	
[140]	Bus ctrl. 4-20 mA	
[141]	Bus ctrl t.o.	
[142]	Bus ctrl t.o. 4-20mA	
[143]	Ext. CL 1 4-20mA	
[144]	Ext. CL 2 4-20mA	
[145]	Ext. CL 3 4-20mA	
[150]	Max Out Fr 4-20 mA	
[184]	Mirror AI53 mA	
[185]	Mirror AI54 mA	

6-81 Terminal X45/3 Min. Scale		
Enter the minimum scaling value of output of the analog signal on terminal X45/3.		
Range:		Function:
0 %*	[0 - 200 %]	

6-82 Terminal X45/3 Max. Scale		
Enter the maximum scaling value of output of the analog signal on terminal X45/3.		
Range:		Function:
100 %*	[0 - 200 %]	

6-83 Terminal X45/3 Bus Control		
Enter the output value for terminal X45/3 when the fieldbus controls the terminal.		
Range:		Function:
0 %*	[0 - 100 %]	

6-84 Terminal X45/3 Output Timeout Preset		
Enter the output value for terminal X45/3 when the bus control timeout for the terminal is detected.		
Range:		Function:
0 %*	[0 - 100 %]	

3.9 Parameters: 8-** Communications and Options

3.9.1 8-** Comm. and Options

3.9.2 8-0* General Settings

8-01 Control Site		
Option:	Function:	
		The setting in this parameter overrides the settings in <i>parameter 8-50 Coasting Select</i> to <i>parameter 8-56 Preset Reference Select</i> .
[0] *	Digital and ctrl.word	Use both digital input and control word.
[1]	Digital only	Use digital inputs only.
[2]	Controlword only	Use control word only.

8-02 Control Source		
Option:	Function:	
		<p>NOTICE</p> <p>This parameter cannot be adjusted while the motor is running.</p> <p>Select the source of the control word: 1 of 2 serial interfaces, or 4 installed options. During initial power-up, the frequency converter automatically sets this parameter to [3] Option A if it detects a valid fieldbus option installed in slot A. If the option is removed, the frequency converter detects a change in the configuration, sets <i>parameter 8-02 Control Source</i> back to default setting [1] FC Port, and the frequency converter then trips. If an option is installed after initial power-up, the setting of <i>parameter 8-02 Control Source</i> does not change but the frequency converter trips and displays <i>alarm 67, Option Changed</i>.</p>
[0]	None	
[1]	FC Port	
[2]	USB Port	
[3]	Option A	
[4]	Option B	
[5]	Option C0	
[6]	Option C1	
[30]	External Can	

8-03 Control Timeout Time		
Range:	Function:	
Size related*	[0.5 - 18000 s]	Enter the maximum time expected to pass between the reception of 2 consecutive telegrams. If this time is exceeded, it indicates that the serial communication has

8-03 Control Timeout Time		
Range:	Function:	
		<p>stopped. The function selected in <i>parameter 8-04 Control Timeout Function</i> is then carried out.</p> <p>The object list holds information on the objects that triggers the control timeout:</p> <ul style="list-style-type: none"> • Analog outputs • Binary outputs • AV0 • AV1 • AV2 • AV4 • BV1 • BV2 • BV3 • BV4 • BV5 • Multistate outputs

8-04 Control Timeout Function		
Option:	Function:	
		Select the timeout function. The timeout function is activated when the control word fails to be updated within the time period specified in <i>parameter 8-03 Control Timeout Time</i> . [20] N2 Override Release only appears after setting the Metasys N2 protocol.
[0] *	Off	
[1]	Freeze output	
[2]	Stop	
[3]	Jogging	
[4]	Max. speed	
[5]	Stop and trip	
[7]	Select setup 1	
[8]	Select setup 2	
[9]	Select setup 3	
[10]	Select setup 4	
[20]	N2 Override Release	
[21]	Min. Reference	
[22]	Max. Reference	

8-05 End-of-Timeout Function		
Option:	Function:	
		<p>Select the action after receiving a valid control word following a timeout.</p> <p>This parameter is active only when <i>parameter 8-04 Control Timeout Function</i> is set to:</p>

8-05 End-of-Timeout Function		
Option:	Function:	
		<ul style="list-style-type: none"> [7] Set-up 1. [8] Set-up 2. [9] Set-up 3. [10] Set-up 4.
[0]	Hold set-up	Retains the set-up selected in <i>parameter 8-04 Control Timeout Function</i> and shows a warning until <i>parameter 8-06 Reset Control Timeout</i> toggles. Then the frequency converter resumes its original set-up.
[1] *	Resume set-up	Resumes the set-up that was active before the timeout.

8-06 Reset Control Timeout		
Option:	Function:	
		This parameter is active only when option [0] <i>Hold set-up</i> has been selected in <i>parameter 8-05 End-of-Timeout Function</i> .
[0] *	Do not reset	Retains the set-up specified in <i>parameter 8-04 Control Timeout Function</i> : <ul style="list-style-type: none"> [7] Set-up 1. [8] Set-up 2. [9] Set-up 3. [10] Set-up 4.
[1]	Do reset	Returns the frequency converter to the original set-up following a control word timeout. When the value is set to [1] <i>Do reset</i> , the frequency converter performs the reset and immediately reverts to the [0] <i>Do not reset</i> setting.

8-07 Diagnosis Trigger		
Option:	Function:	
		To send no extended diagnosis data (EDD), select [0] <i>Disable</i> . To send EDD upon alarms, select [1] <i>Trigger on alarms</i> . To send EDD upon alarms or warnings, select [2] <i>Trigger alarm/warn</i> . Not all fieldbusses support the diagnosis functions.
[0] *	Disable	
[1]	Trigger on alarms	
[2]	Trigger alarm/warn.	

3.9.3 8-1* Ctrl. Word Settings

8-10 Control Profile		
Option:	Function:	
		Select the interpretation of the control and status words corresponding to the

8-10 Control Profile		
Option:	Function:	
		installed fieldbus. Only the selections valid for the fieldbus installed in slot A are visible in the LPC display.
[0] *	FC profile	
[1]	PROFdrive profile	
[5]	ODVA	Available only with VLT® DeviceNet MCA 104 and VLT® EtherNet IP MCA 121.
[7]	CANopen DSP 402	

8-13 Configurable Status Word STW		
Option:	Function:	
		This parameter enables configuration of bits 12–15 in the status word.
[0]	No function	
[1] *	Profile Default	The function corresponds to the profile default selected in <i>parameter 8-10 Control Profile</i> .
[2]	Alarm 68 Only	Only set if <i>alarm 68, Safe Torque Off</i> occurs.
[3]	Trip excl Alarm 68	Set if a trip occurs, except if <i>alarm 68, Safe Torque Off</i> executes the trip.
[16]	T37 DI status	The bit indicates the status of terminal 37. 0 indicates that T37 is low (Safe Torque Off). 1 indicates that T37 is high (normal).

Activate or deactivate the storing of data in non-volatile memory.

8-16 Store Data Values		
Option:	Function:	
[0] *	Off	
[1]	Store all setups	
[2]	Store all setups	

3.9.4 8-3* FC Port Settings

8-30 Protocol		
Option:	Function:	
[0]	FC	Communication according to the FC Protocol as described in the <i>VLT® Refrigeration Drive FC 103 Design Guide, chapter RS485 Installation and Set-up</i> .
[1]	FC MC	Same as [0] FC but to be used when downloading SW to the frequency converter or uploading dll file (covering information

8-30 Protocol		
Protocol selection for the integrated FC (standard) port (RS485) on the control card.		
Option:	Function:	
		regarding parameters available in the frequency converter and their inter-dependencies) to MCT 10 Set-up Software.
[2]	Modbus RTU	Communication according to the Modbus RTU protocol as described in the <i>VLT® Refrigeration Drive FC 103 Design Guide, chapter RS485 Installation and Set-up</i> .
[3]	Metasys N2	Communication protocol. The N2 software protocol is designed to be general in nature in order to accommodate the unique properties each device may have. See <i>VLT® HVAC Drive FC 102 Metasys Operating Instructions</i> .
[9]	FC option	To be used when a gateway is connected to the integrated RS485 port. Following changes take place: <ul style="list-style-type: none"> Address for the FC port is set to 1 and <i>parameter 8-31 Address</i> is now used to set the address for the gateway on the network. Baud rate for the FC port is set to a fixed value (115.200 Baud), and <i>parameter 8-32 Baud Rate</i> is now used to set the baud rate for the network port on the gateway.

NOTICE

Further details can be found in *VLT® HVAC Drive FC 102 Metasys Operating Instructions*.

8-31 Address		
Range:	Function:	
Size related*	[1 - 255]	Enter the address for the frequency converter (standard) port. Valid range: 1–126.

8-32 Baud Rate		
Option:	Function:	
		Baud rates 9600, 19200, 38400, and 76800 are valid for BACnet only. The default value depends on the FC protocol.
[0]	2400 Baud	
[1]	4800 Baud	
[2]	9600 Baud	
[3]	19200 Baud	
[4]	38400 Baud	
[5]	57600 Baud	
[6]	76800 Baud	
[7]	115200 Baud	

8-33 Parity / Stop Bits		
Option:	Function:	
		Parity and stop bits for the protocol <i>parameter 8-30 Protocol</i> using the FC port. For some of the protocols, not all options are visible. Default depends on the protocol selected.
[0]	Even Parity, 1 Stop Bit	
[1]	Odd Parity, 1 Stop Bit	
[2]	No Parity, 1 Stop Bit	
[3]	No Parity, 2 Stop Bits	

8-35 Minimum Response Delay		
Range:	Function:	
10 ms*	[5 - 10000 ms]	Specify the minimum delay time between receiving a request and transmitting a response. This is used for overcoming modem turnaround delays.

8-36 Maximum Response Delay		
Range:	Function:	
Size related*	[11 - 10001 ms]	Specify the maximum allowed delay time between transmitting a request and receiving a response. Exceeding this delay time causes control word timeout.

8-37 Maximum Inter-Char Delay		
Range:	Function:	
Size related*	[0.00 - 35.00 ms]	Specify the maximum allowed time interval between receipt of 2 bytes. This parameter activates timeout if transmission is interrupted.

3.9.5 8-4* Telegram Selection

8-40 Telegram Selection		
Option:	Function:	
		Enables use of freely configurable telegrams or standard telegrams for the FC port.
[1] *	Standard telegram 1	
[100]	None	
[101]	PPO 1	
[102]	PPO 2	
[103]	PPO 3	
[104]	PPO 4	
[105]	PPO 5	
[106]	PPO 6	
[107]	PPO 7	
[108]	PPO 8	
[200]	Custom telegram 1	

8-42 PCD Write Configuration		
Range:	Function:	
[0]	None	
[302]	Minimum Reference	
[303]	Maximum Reference	
[341]	Ramp 1 Ramp Up Time	
[342]	Ramp 1 Ramp Down Time	
[351]	Ramp 2 Ramp Up Time	
[352]	Ramp 2 Ramp Down Time	
[380]	Jog Ramp Time	
[381]	Quick Stop Ramp Time	
[411]	Motor Speed Low Limit [RPM]	
[412]	Motor Speed Low Limit [Hz]	
[413]	Motor Speed High Limit [RPM]	
[414]	Motor Speed High Limit [Hz]	
[416]	Torque Limit Motor Mode	
[417]	Torque Limit Generator Mode	
[553]	Term. 29 High Ref./Feedb. Value	
[558]	Term. 33 High Ref./Feedb. Value	
[590]	Digital & Relay Bus Control	
[593]	Pulse Out #27 Bus Control	
[595]	Pulse Out #29 Bus Control	
[597]	Pulse Out #X30/6 Bus Control	
[615]	Terminal 53 High Ref./Feedb. Value	
[625]	Terminal 54 High Ref./Feedb. Value	
[653]	Terminal 42 Output Bus Control	
[663]	Terminal X30/8 Output Bus Control	
[673]	Terminal X45/1 Bus Control	
[683]	Terminal X45/3 Bus Control	
[890]	Bus Jog 1 Speed	
[891]	Bus Jog 2 Speed	
[894]	Bus Feedback 1	
[895]	Bus Feedback 2	
[896]	Bus Feedback 3	
[1680]	Fieldbus CTW 1	

8-42 PCD Write Configuration		
Range:	Function:	
[1682]	Fieldbus REF 1	
[1685]	FC Port CTW 1	
[1686]	FC Port REF 1	
[2021]	Setpoint 1	
[2022]	Setpoint 2	
[2023]	Setpoint 3	
[2643]	Terminal X42/7 Bus Control	
[2653]	Terminal X42/9 Bus Control	
[2663]	Terminal X42/11 Bus Control	

8-43 PCD Read Configuration		
Range:	Function:	
[0]	None	
[894]	Bus Feedback 1	
[895]	Bus Feedback 2	
[896]	Bus Feedback 3	
[1397]	Alert Alarm Word	
[1398]	Alert Warning Word	
[1399]	Alert Status Word	
[1500]	Operating hours	
[1501]	Running Hours	
[1502]	kWh Counter	
[1600]	Control Word	
[1601]	Reference [Unit]	
[1602]	Reference [%]	
[1603]	Status Word	
[1605]	Main Actual Value [%]	
[1609]	Custom Readout	
[1610]	Power [kW]	
[1611]	Power [hp]	
[1612]	Motor Voltage	
[1613]	Frequency	
[1614]	Motor current	
[1615]	Frequency [%]	
[1616]	Torque [Nm]	
[1617]	Speed [RPM]	
[1618]	Motor Thermal	
[1622]	Torque [%]	
[1624]	Calibrated Stator Resistance	
[1630]	DC Link Voltage	
[1632]	Brake Energy /s	
[1633]	Brake Energy /2 min	
[1634]	Heatsink Temp.	
[1635]	Inverter Thermal	
[1638]	SL Controller State	
[1639]	Control Card Temp.	
[1650]	External Reference	
[1652]	Feedback[Unit]	
[1653]	Digi Pot Reference	
[1654]	Feedback 1 [Unit]	
[1655]	Feedback 2 [Unit]	
[1656]	Feedback 3 [Unit]	

8-43 PCD Read Configuration		
Range:	Function:	
[1660]	Digital Input	
[1661]	Terminal 53 Switch Setting	
[1662]	Analog Input 53	
[1663]	Terminal 54 Switch Setting	
[1664]	Analog Input 54	
[1665]	Analog Output 42 [mA]	
[1666]	Digital Output [bin]	
[1667]	Pulse Input #29 [Hz]	
[1668]	Pulse Input #33 [Hz]	
[1669]	Pulse Output #27 [Hz]	
[1670]	Pulse Output #29 [Hz]	
[1671]	Relay Output [bin]	
[1672]	Counter A	
[1673]	Counter B	
[1675]	Analog In X30/11	
[1676]	Analog In X30/12	
[1677]	Analog Out X30/8 [mA]	
[1678]	Analog Out X45/1 [mA]	
[1679]	Analog Out X45/3 [mA]	
[1684]	Comm. Option STW	
[1685]	FC Port CTW 1	
[1690]	Alarm Word	
[1691]	Alarm Word 2	
[1692]	Warning Word	
[1693]	Warning Word 2	
[1694]	Ext. Status Word	
[1695]	Ext. Status Word 2	
[1696]	Maintenance Word	
[1699]	Ext. Status Word 3	
[1830]	Analog Input X42/1	
[1831]	Analog Input X42/3	
[1832]	Analog Input X42/5	
[1833]	Analog Out X42/7 [V]	
[1834]	Analog Out X42/9 [V]	
[1835]	Analog Out X42/11 [V]	
[1860]	Digital Input 2	
[2827]	Discharge Temperature	

8-45 BTM Transaction Command		
Option:	Function:	
[0] *	Off	
[1]	Start Transaction	
[2]	Commit transaction	
[3]	Clear error	

8-46 BTM Transaction Status		
Option:	Function:	
[0] *	Off	
[1]	Transaction Started	
[2]	Transaction Comitting	
[3]	Transaction Timeout	
[4]	Err. Non-existing Par.	

8-46 BTM Transaction Status		
Option:	Function:	
[5]	Err. Par. Out of Range	

8-47 BTM Timeout		
Range:	Function:	
60 s*	[0 - 360 s]	

3.9.6 8-5* Digital/Bus

Parameters for configuring the control word merging.

NOTICE

These parameters are active only when *parameter 8-01 Control Site* is set to [0] Digital and control word.

8-50 Coasting Select		
Option:	Function:	
		Select the trigger for the coasting function.
[0]	Digital input	A digital input triggers the coasting function.
[1]	Bus	A serial communication port or the fieldbus triggers the coasting function.
[2]	Logic AND	The fieldbus/serial communication port and a digital input trigger the coasting function.
[3] *	Logic OR	The fieldbus/serial communication port or a digital input triggers the coasting function.

8-52 DC Brake Select		
Option:	Function:	
		Select control of the DC brake via the terminals (digital input) and/or via the fieldbus.
		NOTICE When <i>parameter 1-10 Motor Construction</i> is set to [1] PM non-salient SPM, only selection [0] Digital input is available.
[0]	Digital input	Activate a start command via a digital input.
[1]	Bus	Activate a start command via the serial communication port or fieldbus option.
[2]	Logic AND	Activate a start command via the fieldbus/serial communication port, and also via 1 of the digital inputs.
[3]	Logic OR	Activate a start command via the fieldbus/serial communication port, or via 1 of the digital inputs.

8-53 Start Select		
Option:	Function:	
		Select the trigger for the start function.
[0]	Digital input	A digital input triggers the start function.
[1]	Bus	A serial communication port or the fieldbus triggers the start function.
[2]	Logic AND	The fieldbus/serial communication port and a digital input trigger the start function.
[3] *	Logic OR	The fieldbus/serial communication port or a digital input triggers the start function.

8-54 Reversing Select		
Option:	Function:	
		<p>NOTICE</p> <p>This parameter is active only when parameter 8-01 Control Site is set to [0] Digital and control word.</p> <p>Select control of the frequency converter reverse function via the terminals (digital input) and/or via the fieldbus.</p>
[0] *	Digital input	Activates reverse command via a digital input.
[1]	Bus	Activates reverse command via the serial communication port or fieldbus option.
[2]	Logic AND	Activates reverse command via the fieldbus/serial communication port, AND via 1 of the digital inputs.
[3]	Logic OR	Activates reverse command via the fieldbus/serial communication port OR via 1 of the digital inputs.

8-55 Set-up Select		
Option:	Function:	
		Select the trigger for the set-up selection.
[0]	Digital input	A digital input triggers the set-up selection.
[1]	Bus	A serial communication port or the fieldbus triggers the set-up selection.
[2]	Logic AND	The fieldbus/serial communication port and a digital input trigger the set-up selection.
[3] *	Logic OR	The fieldbus/serial communication port or a digital input triggers the set-up selection.

8-56 Preset Reference Select		
Option:	Function:	
		Select the trigger for the preset reference selection.
[0]	Digital input	A digital input triggers the preset reference selection.

8-56 Preset Reference Select		
Option:	Function:	
[1]	Bus	A serial communication port or the fieldbus triggers the preset reference selection.
[2]	Logic AND	The fieldbus/serial communication port and a digital input trigger the preset reference selection.
[3] *	Logic OR	The fieldbus/serial communication port or a digital input triggers the preset reference selection.

3.9.7 8-8* FC Port Diagnostics

These parameters are used for monitoring the bus communication via the frequency converter port.

8-80 Bus Message Count		
Range:	Function:	
0*	[0 - 0]	This parameter shows the number of valid telegrams detected on the bus.

8-81 Bus Error Count		
Array [6]		
Range:	Function:	
0*	[0 - 0]	This parameter shows the number of telegrams with faults (for example CRC fault) detected on the bus.

8-82 Slave Message Count		
Range:	Function:	
0*	[0 - 0]	This parameter shows the number of valid telegrams addressed to the slave sent by the frequency converter.

8-83 Slave Error Count		
Range:	Function:	
0*	[0 - 0]	This parameter shows the number of error telegrams, which could not be executed by the frequency converter.

3.9.8 8-9* Bus Jog

8-90 Bus Jog 1 Speed		
Range:	Function:	
100 RPM*	[0 - par. 4-13 RPM]	Enter the jog speed. Activate this fixed jog speed via the serial port or fieldbus option.

8-91 Bus Jog 2 Speed		
Range:		Function:
Size related*	[0 - par. 4-13 RPM]	Enter the jog speed. Activate this fixed jog speed via the serial port or fieldbus option.

8-94 Bus Feedback 1		
Range:		Function:
0*	[-200 - 200]	Write feedback to this parameter via the serial communication port or fieldbus option. This parameter must be selected in <i>parameter 20-00 Feedback 1 Source</i> , <i>parameter 20-03 Feedback 2 Source</i> , or <i>parameter 20-06 Feedback 3 Source</i> as a feedback source.

8-95 Bus Feedback 2		
Range:		Function:
0*	[-200 - 200]	See <i>parameter 8-94 Bus Feedback 1</i> for further details.

8-96 Bus Feedback 3		
Range:		Function:
0*	[-200 - 200]	See <i>parameter 8-94 Bus Feedback 1</i> for further details.

3.10 Parameters: 11-** FC 103 LON

This section contains the descriptions of parameters related to LonWorks.

3.10.1 11-2* LON Param. Access

11-21 Store Data Values		
Select whether the frequency converter stores the data in non-volatile memory.		
Option:	Function:	
[0] *	Off	
[2]	Store all setups	

3.10.2 11-9* AK LonWorks

11-90 VLT Network Address		
Enter the network address of the frequency converter.		
Range:	Function:	
0*	[0 - 999]	

11-91 AK Service Pin		
Send the AK address over the network.		
Option:	Function:	
[0] *	Off	No action.
[1]	On	Send the AK address over the network.

11-98 Alarm Text		
Shows a description of the alarm.		
Range:	Function:	
0*	[0 - 32]	

11-99 Alarm Status		
Shows a status of the alarm.		
Range:	Function:	
0*	[0 - 1]	

3.11 Parameters: 13-** Smart Logic

3.11.1 13-** Prog. Features

Smart logic control (SLC) is a sequence of user-defined actions (see *parameter 13-52 SL Controller Action [x]*) executed by the SLC when the associated user-defined event (see *parameter 13-51 SL Controller Event [x]*) is evaluated as true by the SLC. Events and actions are each numbered and linked together in pairs. This means that when [0] event is fulfilled (attains the value true), [0] action is executed. After this, the conditions of [1] event are evaluated and if evaluated true, [1] action is executed and so on. Only 1 event is evaluated at any time. If an event is evaluated as false, nothing happens (in the SLC) during the current scan interval and no other events are evaluated. This means that when the SLC starts, it evaluates [0] event (and only [0] event) at each scan interval. Only when [0] event is evaluated true, the SLC executes [0] action and starts evaluating [1] event. It is possible to program from 1 to 20 events and actions.

When the last event/action has been executed, the sequence starts over again from [0] event/[0] action.

Illustration 3.35 shows an example with 3 events/actions.

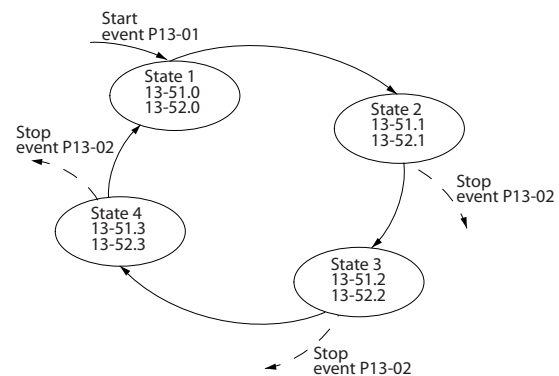

Illustration 3.35 Example with 3 Events/Actions

Starting and stopping the SLC

Start and stop the SLC by selecting [1] On or [0] Off in *parameter 13-00 SL Controller Mode*. The SLC always starts in state 0 (where it evaluates [0] event). The SLC starts when the start event (defined in *parameter 13-01 Start Event*) is evaluated as true (provided that [1] On is selected in *parameter 13-00 SL Controller Mode*). The SLC stops when the stop event (*parameter 13-02 Stop Event*) is true. *Parameter 13-03 Reset SLC* resets all SLC parameters and starts programming from scratch.

3.11.2 13-0* SLC Settings

Use the SLC settings to activate, deactivate, and reset the smart logic control sequence. The logic functions and comparators are always running in the background, which opens for separate control of digital inputs and outputs.

13-00 SL Controller Mode		
Option:	Function:	
[0]	Off	Disables the smart logic controller.
[1]	On	Enables the smart logic controller.

13-01 Start Event		
Option:	Function:	
		Select the boolean (true or false) input to activate smart logic control.
[0]	False	Enters the fixed value of false in the logic rule.
[1]	True	Enters the fixed value true in the logic rule.
[2]	Running	See <i>parameter group 5-3* Digital Outputs</i> for further description.
[3]	In range	See <i>parameter group 5-3* Digital Outputs</i> for further description.
[4]	On reference	See <i>parameter group 5-3* Digital Outputs</i> for further description.
[5]	Torque limit	See <i>parameter group 5-3* Digital Outputs</i> for further description.
[6]	Current Limit	See <i>parameter group 5-3* Digital Outputs</i> for further description.
[7]	Out of current range	See <i>parameter group 5-3* Digital Outputs</i> for further description.
[8]	Below I low	See <i>parameter group 5-3* Digital Outputs</i> for further description.
[9]	Above I high	See <i>parameter group 5-3* Digital Outputs</i> for further description.
[10]	Out of speed range	
[11]	Below speed low	See <i>parameter group 5-3* Digital Outputs</i> for further description.
[12]	Above speed high	See <i>parameter group 5-3* Digital Outputs</i> for further description.
[13]	Out of feedb. range	
[14]	Below feedb. low	
[15]	Above feedb. high	
[16]	Thermal warning	See <i>parameter group 5-3* Digital Outputs</i> for further description.
[17]	Mains out of range	See <i>parameter group 5-3* Digital Outputs</i> for further description.
[18]	Reversing	See <i>parameter group 5-3* Digital Outputs</i> for further description.
[19]	Warning	See <i>parameter group 5-3* Digital Outputs</i> for further description.

13-01 Start Event		
Option:	Function:	
[20]	Alarm (trip)	See <i>parameter group 5-3* Digital Outputs</i> for further description.
[21]	Alarm (trip lock)	See <i>parameter group 5-3* Digital Outputs</i> for further description.
[22]	Comparator 0	Use the result of comparator 0 in the logic rule.
[23]	Comparator 1	Use the result of comparator 1 in the logic rule.
[24]	Comparator 2	Use the result of comparator 2 in the logic rule.
[25]	Comparator 3	Use the result of comparator 3 in the logic rule.
[26]	Logic rule 0	Use the result of logic rule 0 in the logic rule.
[27]	Logic rule 1	Use the result of logic rule 1 in the logic rule.
[28]	Logic rule 2	Use the result of logic rule 2 in the logic rule.
[29]	Logic rule 3	Use the result of logic rule 3 in the logic rule.
[33]	Digital input DI18	Use the value of DI18 in the logic rule (High = true).
[34]	Digital input DI19	Use the value of DI19 in the logic rule (High = true).
[35]	Digital input DI27	Use the value of DI27 in the logic rule (High = true).
[36]	Digital input DI29	Use the value of DI29 in the logic rule (High = true).
[37]	Digital input DI32	Use the value of DI32 in the logic rule (High = true).
[38]	Digital input DI33	Use the value of DI33 in the logic rule (High = true).
[39]	Start command	This event is true if the frequency converter is started (either via digital input, fieldbus, or other).
[40]	Drive stopped	This event is true if the frequency converter is stopped or coasted (either via digital input, fieldbus, or other).
[41]	Reset Trip	This event is true if the frequency converter is tripped (but not trip-locked) and [Reset] is pressed.
[42]	Auto Reset Trip	This event is true if the frequency converter is tripped (but not trip-locked) and an automatic reset is issued.
[43]	OK Key	This event is true if [OK] is pressed.
[44]	Reset Key	This event is true if [Reset] is pressed.

13-01 Start Event		
Option:	Function:	
[45]	Left Key	This event is true if [◀] is pressed.
[46]	Right Key	This event is true if [▶] is pressed.
[47]	Up Key	This event is true if [▲] is pressed.
[48]	Down Key	This event is true if [▼] is pressed.
[50]	Comparator 4	Use the result of comparator 4 in the logic rule.
[51]	Comparator 5	Use the result of comparator 5 in the logic rule.
[60]	Logic rule 4	Use the result of logic rule 4 in the logic rule.
[61]	Logic rule 5	Use the result of logic rule 5 in the logic rule.

13-02 Stop Event		
Option:	Function:	
		Select the boolean (true or false) input to deactivate smart logic control.
[0]	False	Enters the fixed value of false in the logic rule.
[1]	True	Enters the fixed value true in the logic rule.
[2]	Running	See <i>parameter group 5-3* Digital Outputs</i> for further description.
[3]	In range	See <i>parameter group 5-3* Digital Outputs</i> for further description.
[4]	On reference	See <i>parameter group 5-3* Digital Outputs</i> for further description.
[5]	Torque limit	See <i>parameter group 5-3* Digital Outputs</i> for further description.
[6]	Current Limit	See <i>parameter group 5-3* Digital Outputs</i> for further description.
[7]	Out of current range	See <i>parameter group 5-3* Digital Outputs</i> for further description.
[8]	Below I low	See <i>parameter group 5-3* Digital Outputs</i> for further description.
[9]	Above I high	See <i>parameter group 5-3* Digital Outputs</i> for further description.
[10]	Out of speed range	
[11]	Below speed low	See <i>parameter group 5-3* Digital Outputs</i> for further description.
[12]	Above speed high	See <i>parameter group 5-3* Digital Outputs</i> for further description.
[13]	Out of feedb. range	See <i>parameter group 5-3* Digital Outputs</i> for further description.

13-02 Stop Event		
Option:	Function:	
[14]	Below feedb. low	See <i>parameter group 5-3* Digital Outputs</i> for further description.
[15]	Above feedb. high	See <i>parameter group 5-3* Digital Outputs</i> for further description.
[16]	Thermal warning	See <i>parameter group 5-3* Digital Outputs</i> for further description.
[17]	Mains out of range	See <i>parameter group 5-3* Digital Outputs</i> for further description.
[18]	Reversing	See <i>parameter group 5-3* Digital Outputs</i> for further description.
[19]	Warning	See <i>parameter group 5-3* Digital Outputs</i> for further description.
[20]	Alarm (trip)	See <i>parameter group 5-3* Digital Outputs</i> for further description.
[21]	Alarm (trip lock)	See <i>parameter group 5-3* Digital Outputs</i> for further description.
[22]	Comparator 0	Use the result of comparator 0 in the logic rule.
[23]	Comparator 1	Use the result of comparator 1 in the logic rule.
[24]	Comparator 2	Use the result of comparator 2 in the logic rule.
[25]	Comparator 3	Use the result of comparator 3 in the logic rule.
[26]	Logic rule 0	Use the result of logic rule 0 in the logic rule.
[27]	Logic rule 1	Use the result of logic rule 1 in the logic rule.
[28]	Logic rule 2	Use the result of logic rule 2 in the logic rule.
[29]	Logic rule 3	Use the result of logic rule 3 in the logic rule.
[30]	SL Time-out 0	Use the result of timer 0 in the logic rule.
[31]	SL Time-out 1	Use the result of timer 1 in the logic rule.
[32]	SL Time-out 2	Use the result of timer 2 in the logic rule.
[33]	Digital input DI18	Use the value of DI 18 in the logic rule (High = true).
[34]	Digital input DI19	Use the value of DI 19 in the logic rule (High = true).
[35]	Digital input DI27	Use the value of DI 27 in the logic rule (High = true).
[36]	Digital input DI29	Use the value of DI 29 in the logic rule (High = true).

13-02 Stop Event		
Option:	Function:	
[37]	Digital input DI32	Use the value of DI 32 in the logic rule (High = true).
[38]	Digital input DI33	Use the value of DI 33 in the logic rule (High = true).
[39]	Start command	This event is true if the frequency converter is started (either via digital input, fieldbus or other).
[40]	Drive stopped	This event is true if the frequency converter is stopped or coasted (either via digital input, fieldbus or other).
[41]	Reset Trip	This event is true if the frequency converter is tripped (but not trip-locked) and [Reset] is pressed.
[42]	Auto Reset Trip	This event is true if the frequency converter is tripped (but not trip-locked) and an automatic reset is issued.
[43]	OK Key	This event is true if [OK] is pressed.
[44]	Reset Key	This event is true if [Reset] is pressed.
[45]	Left Key	This event is true if [◀] is pressed.
[46]	Right Key	This event is true if [▶] is pressed.
[47]	Up Key	This event is true if [▲] is pressed.
[48]	Down Key	This event is true if [▼] is pressed.
[50]	Comparator 4	Use the result of comparator 4 in the logic rule.
[51]	Comparator 5	Use the result of comparator 5 in the logic rule.
[60]	Logic rule 4	Use the result of logic rule 4 in the logic rule.
[61]	Logic rule 5	Use the result of logic rule 5 in the logic rule.
[70]	SL Time-out 3	Use the result of timer 3 in the logic rule.
[71]	SL Time-out 4	Use the result of timer 4 in the logic rule.
[72]	SL Time-out 5	Use the result of timer 5 in the logic rule.
[73]	SL Time-out 6	Use the result of timer 6 in the logic rule.
[74]	SL Time-out 7	Use the result of timer 7 in the logic rule.
[80]	No Flow	
[81]	Dry Pump	
[82]	End of Curve	
[83]	Broken Belt	

13-03 Reset SLC		
Option:	Function:	
[0] *	Do not reset SLC	Retains programmed settings in <i>parameter group 13-** Smart Logic</i> .
[1]	Reset SLC	Resets all parameters in <i>parameter group 13-** Smart Logic</i> to default settings.

3.11.3 13-1* Comparators

13-10 Comparator Operand		
Array [5]		
Option:	Function:	
		Select the variable to be monitored by the comparator.
[0]	DISABLED	
[1]	Reference %	
[2]	Feedback %	
[3]	Motor speed	
[4]	Motor Current	
[5]	Motor torque	
[6]	Motor power	
[7]	Motor voltage	
[8]	DC-link voltage	
[9]	Motor Thermal	
[10]	Drive thermal	
[11]	Heat sink temp.	
[12]	Analog input AI53	
[13]	Analog input AI54	
[14]	Analog input AIFB10	
[15]	Analog input AIS24V	
[17]	Analog input AICCT	
[18]	Pulse input FI29	
[19]	Pulse input FI33	
[20]	Alarm number	
[21]	Warning number	
[22]	Analog input x30 11	
[23]	Analog input x30 12	
[29]	Number Of Pump Running	
[30]	Counter A	
[31]	Counter B	
[40]	Analog input x42/1	
[41]	Analog input x42/3	
[42]	Analog input x42/5	
[50]	FALSE	
[51]	TRUE	
[52]	Control ready	
[53]	Drive ready	
[54]	Running	
[55]	Reversing	
[56]	In range	
[60]	On reference	
[61]	Below reference, low	
[62]	Above ref, high	

13-10 Comparator Operand	
Array [5]	
Option:	Function:
[65]	Torque limit
[66]	Current Limit
[67]	Out of current range
[68]	Below I low
[69]	Above I high
[70]	Out of speed range
[71]	Below speed low
[72]	Above speed high
[75]	Out of feedback range
[76]	Below feedback low
[77]	Above feedback high
[80]	Thermal warning
[82]	Mains out of range
[85]	Warning
[86]	Alarm (trip)
[87]	Alarm (trip lock)
[90]	Bus OK
[91]	Torque limit & stop
[92]	Brake fault (IGBT)
[93]	Mech. brake control
[94]	Safe stop active
[100]	Comparator 0
[101]	Comparator 1
[102]	Comparator 2
[103]	Comparator 3
[104]	Comparator 4
[105]	Comparator 5
[110]	Logic rule 0
[111]	Logic rule 1
[112]	Logic rule 2
[113]	Logic rule 3
[114]	Logic rule 4
[115]	Logic rule 5
[120]	SL Time-out 0
[121]	SL Time-out 1
[122]	SL Time-out 2
[123]	SL Time-out 3
[124]	SL Time-out 4
[125]	SL Time-out 5
[126]	SL Time-out 6
[127]	SL Time-out 7
[130]	Digital input DI18
[131]	Digital input DI19
[132]	Digital input DI27
[133]	Digital input DI29
[134]	Digital input DI32
[135]	Digital input DI33
[150]	SL digital output A
[151]	SL digital output B
[152]	SL digital output C
[153]	SL digital output D

13-10 Comparator Operand	
Array [5]	
Option:	Function:
[154]	SL digital output E
[155]	SL digital output F
[160]	Relay 1
[161]	Relay 2
[180]	Local reference active
[181]	Remote reference active
[182]	Start command
[183]	Drive stopped
[185]	Drive in hand mode
[186]	Drive in auto mode
[187]	Start command given
[190]	Digital input x30/2
[191]	Digital input x30/3
[192]	Digital input x30/4
[205]	No Flow
[206]	Dry Pump
[207]	End of Curve
[208]	Broken Belt

13-11 Comparator Operator		
Array [6]		
Option:	Function:	
[0]	<	Select [0] < for the result of the evaluation to be true, when the variable selected in <i>parameter 13-10 Comparator Operand</i> is smaller than the fixed value in <i>parameter 13-12 Comparator Value</i> . The result is false, if the variable selected in <i>parameter 13-10 Comparator Operand</i> is greater than the fixed value in <i>parameter 13-12 Comparator Value</i> .
[1]	≈ (equal)	Select [1] ≈ for the result of the evaluation to be true, when the variable selected in <i>parameter 13-10 Comparator Operand</i> is approximately equal to the fixed value in <i>parameter 13-12 Comparator Value</i> .
[2]	>	Select [2] > for the inverse logic of option [0] <.
[5]	TRUE longer than..	
[6]	FALSE longer than..	
[7]	TRUE shorter than..	
[8]	FALSE shorter than..	

13-12 Comparator Value		
Array [6]		
Range:		Function:
Size related*	[-100000 - 100000]	Enter the trigger level for the variable that is monitored by this comparator. This is an array parameter containing comparator values 0-5.

3.11.4 13-2* Timers

Use the result (true or false) from timers directly to define an event (see *parameter 13-51 SL Controller Event*), or as boolean input in a logic rule (see *parameter 13-40 Logic Rule Boolean 1*, *parameter 13-42 Logic Rule Boolean 2*, or *parameter 13-44 Logic Rule Boolean 3*). A timer is only false when started by an action (for example [29] *Start timer 1*) until the timer value entered in this parameter has elapsed. Then it becomes true again. All parameters in this parameter group are array parameters with index 0-2. Select index 0 to program timer 0, select index 1 to program timer 1, and so on.

13-20 SL Controller Timer		
Array [8]		
Range:		Function:
Size related*	[0 - 0]	Enter the value to define the duration of the false output from the programmed timer.

3.11.5 13-4* Logic Rules

Combine up to 3 boolean inputs (true/false inputs) from timers, comparators, digital inputs, status bits, and events using the logical operators AND, OR, and NOT. Select boolean inputs for the calculation in *parameter 13-40 Logic Rule Boolean 1*, *parameter 13-42 Logic Rule Boolean 2*, and *parameter 13-44 Logic Rule Boolean 3*. Define the operators used to logically combine the selected inputs in *parameter 13-41 Logic Rule Operator 1* and *parameter 13-43 Logic Rule Operator 2*.

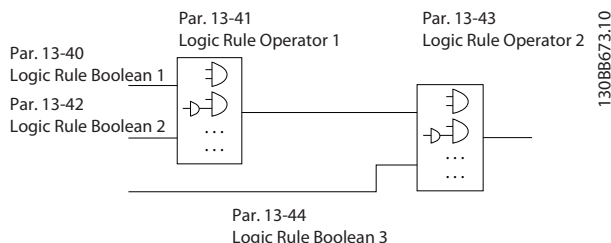

Illustration 3.36 Logic Rules

Priority of calculation

The results of *parameter 13-40 Logic Rule Boolean 1*, *parameter 13-41 Logic Rule Operator 1*, and *parameter 13-42 Logic Rule Boolean 2* are calculated first. The outcome (true/false) of this calculation is combined with the settings of *parameter 13-43 Logic Rule Operator 2* and *parameter 13-44 Logic Rule Boolean 3*, yielding the final result (true/false) of the logic rule.

13-40 Logic Rule Boolean 1		
Array [6]		
Option:		Function:
[0]	False	Enters the fixed value of false in the logic rule.
[1]	True	Enters the fixed value true in the logic rule.
[2]	Running	See <i>parameter group 5-3* Digital Outputs</i> for further description.
[3]	In range	See <i>parameter group 5-3* Digital Outputs</i> for further description.
[4]	On reference	See <i>parameter group 5-3* Digital Outputs</i> for further description.
[5]	Torque limit	See <i>parameter group 5-3* Digital Outputs</i> for further description.
[6]	Current Limit	See <i>parameter group 5-3* Digital Outputs</i> for further description.
[7]	Out of current range	See <i>parameter group 5-3* Digital Outputs</i> for further description.
[8]	Below I low	See <i>parameter group 5-3* Digital Outputs</i> for further description.
[9]	Above I high	See <i>parameter group 5-3* Digital Outputs</i> for further description.
[10]	Out of speed range	
[11]	Below speed low	See <i>parameter group 5-3* Digital Outputs</i> for further description.
[12]	Above speed high	See <i>parameter group 5-3* Digital Outputs</i> for further description.
[13]	Out of feedb. range	See <i>parameter group 5-3* Digital Outputs</i> for further description.
[14]	Below feedb. low	See <i>parameter group 5-3* Digital Outputs</i> for further description.
[15]	Above feedb. high	See <i>parameter group 5-3* Digital Outputs</i> for further description.
[16]	Thermal warning	See <i>parameter group 5-3* Digital Outputs</i> for further description.
[17]	Mains out of range	See <i>parameter group 5-3* Digital Outputs</i> for further description.
[18]	Reversing	See <i>parameter group 5-3* Digital Outputs</i> for further description.

13-40 Logic Rule Boolean 1		
Array [6]		
Option:	Function:	
[19] Warning	See <i>parameter group 5-3* Digital Outputs</i> for further description.	
[20] Alarm (trip)	See <i>parameter group 5-3* Digital Outputs</i> for further description.	
[21] Alarm (trip lock)	See <i>parameter group 5-3* Digital Outputs</i> for further description.	
[22] Comparator 0	Use the result of comparator 0 in the logic rule.	
[23] Comparator 1	Use the result of comparator 1 in the logic rule.	
[24] Comparator 2	Use the result of comparator 2 in the logic rule.	
[25] Comparator 3	Use the result of comparator 3 in the logic rule.	
[26] Logic rule 0	Use the result of logic rule 0 in the logic rule.	
[27] Logic rule 1	Use the result of logic rule 1 in the logic rule.	
[28] Logic rule 2	Use the result of logic rule 2 in the logic rule.	
[29] Logic rule 3	Use the result of logic rule 3 in the logic rule.	
[30] SL Time-out 0	Use the result of timer 0 in the logic rule.	
[31] SL Time-out 1	Use the result of timer 1 in the logic rule.	
[32] SL Time-out 2	Use the result of timer 2 in the logic rule.	
[33] Digital input DI18	Use the value of DI 18 in the logic rule (High = true).	
[34] Digital input DI19	Use the value of DI 19 in the logic rule (High = true).	
[35] Digital input DI27	Use the value of DI 27 in the logic rule (High = true).	
[36] Digital input DI29	Use the value of DI 29 in the logic rule (High = true).	
[37] Digital input DI32	Use the value of DI 32 in the logic rule (High = true).	
[38] Digital input DI33	Use the value of DI 33 in the logic rule (High = true).	
[39] Start command	This logic rule is true if the frequency converter is started either via digital input, fieldbus, or other.	

13-40 Logic Rule Boolean 1		
Array [6]		
Option:	Function:	
[40] Drive stopped	This logic rule is true if the frequency converter is stopped or coasted either via digital input, fieldbus, or other.	
[41] Reset Trip	This logic rule is true if the frequency converter is tripped (but not trip-locked) and [Reset] is pressed.	
[42] Auto Reset Trip	This logic rule is true if the frequency converter is tripped (but not trip-locked) and an automatic reset is issued.	
[43] OK Key	This logic rule is true if [OK] is pressed.	
[44] Reset Key	This logic rule is true if [Reset] is pressed.	
[45] Left Key	This logic rule is true if [◀] is pressed.	
[46] Right Key	This logic rule is true if [▶] is pressed.	
[47] Up Key	This logic rule is true if [▲] is pressed.	
[48] Down Key	This logic rule is true if [▼] is pressed.	
[50] Comparator 4	Use the result of comparator 4 in the logic rule.	
[51] Comparator 5	Use the result of comparator 5 in the logic rule.	
[60] Logic rule 4	Use the result of logic rule 4 in the logic rule.	
[61] Logic rule 5	Use the result of logic rule 5 in the logic rule.	
[70] SL Time-out 3	Use the result of timer 3 in the logic rule.	
[71] SL Time-out 4	Use the result of timer 4 in the logic rule.	
[72] SL Time-out 5	Use the result of timer 5 in the logic rule.	
[73] SL Time-out 6	Use the result of timer 6 in the logic rule.	
[74] SL Time-out 7	Use the result of timer 7 in the logic rule.	
[80] No Flow		
[81] Dry Pump		
[82] End of Curve		
[83] Broken Belt		

13-41 Logic Rule Operator 1		
Array [6]		
Option:	Function:	
	Select the 1 st logical operator to use on the boolean inputs from <i>parameter 13-40 Logic Rule Boolean 1</i> and <i>parameter 13-42 Logic Rule Boolean 2</i> .	

13-41 Logic Rule Operator 1		
Array [6]		
Option:	Function:	
		Parameter numbers in square brackets stand for the boolean inputs of parameters in <i>chapter 3.11 Parameters: 13-** Smart Logic</i> .
[0]	DISABLED	Ignores: <ul style="list-style-type: none"> Parameter 13-42 Logic Rule Boolean 2. Parameter 13-43 Logic Rule Operator 2. Parameter 13-44 Logic Rule Boolean 3.
[1]	AND	Evaluates the expression [13-40] AND [13-42].
[2]	OR	Evaluates the expression [13-40] OR [13-42].
[3]	AND NOT	Evaluates the expression [13-40] AND NOT [13-42].
[4]	OR NOT	Evaluates the expression [13-40] OR NOT [13-42].
[5]	NOT AND	Evaluates the expression NOT [13-40] AND [13-42].
[6]	NOT OR	Evaluates the expression NOT [13-40] OR [13-42].
[7]	NOT AND NOT	Evaluates the expression NOT [13-40] AND NOT [13-42].
[8]	NOT OR NOT	Evaluates the expression NOT [13-40] OR NOT [13-42].

13-42 Logic Rule Boolean 2		
Array [6]		
Option:	Function:	
		Select the 2 nd boolean (true or false) input for the selected logic rule. See <i>parameter 13-40 Logic Rule Boolean 1</i> for further descriptions of options and their functions.
[0]	False	
[1]	True	
[2]	Running	
[3]	In range	
[4]	On reference	
[5]	Torque limit	
[6]	Current Limit	
[7]	Out of current range	
[8]	Below I low	
[9]	Above I high	
[10]	Out of speed range	
[11]	Below speed low	
[12]	Above speed high	
[13]	Out of feedb. range	
[14]	Below feedb. low	
[15]	Above feedb. high	
[16]	Thermal warning	

13-42 Logic Rule Boolean 2		
Array [6]		
Option:	Function:	
[17]	Mains out of range	
[18]	Reversing	
[19]	Warning	
[20]	Alarm (trip)	
[21]	Alarm (trip lock)	
[22]	Comparator 0	
[23]	Comparator 1	
[24]	Comparator 2	
[25]	Comparator 3	
[26]	Logic rule 0	
[27]	Logic rule 1	
[28]	Logic rule 2	
[29]	Logic rule 3	
[30]	SL Time-out 0	
[31]	SL Time-out 1	
[32]	SL Time-out 2	
[33]	Digital input DI18	
[34]	Digital input DI19	
[35]	Digital input DI27	
[36]	Digital input DI29	
[37]	Digital input DI32	
[38]	Digital input DI33	
[39]	Start command	
[40]	Drive stopped	
[41]	Reset Trip	
[42]	Auto Reset Trip	
[43]	OK Key	
[44]	Reset Key	
[45]	Left Key	
[46]	Right Key	
[47]	Up Key	
[48]	Down Key	
[50]	Comparator 4	
[51]	Comparator 5	
[60]	Logic rule 4	
[61]	Logic rule 5	
[70]	SL Time-out 3	
[71]	SL Time-out 4	
[72]	SL Time-out 5	
[73]	SL Time-out 6	
[74]	SL Time-out 7	
[80]	No Flow	
[81]	Dry Pump	
[82]	End of Curve	
[83]	Broken Belt	

13-43 Logic Rule Operator 2		
Array [6]		
Option:	Function:	
	Select the 2 nd logical operator to be used on the boolean input calculated in: <ul style="list-style-type: none"> Parameter 13-40 Logic Rule Boolean 1. Parameter 13-41 Logic Rule Operator 1. Parameter 13-42 Logic Rule Boolean 2. Parameter 13-42 Logic Rule Boolean 2. [13-44] signifies the boolean input of parameter 13-44 Logic Rule Boolean 3. [13-40/13-42] signifies the boolean input calculated in: <ul style="list-style-type: none"> Parameter 13-40 Logic Rule Boolean 1. Parameter 13-41 Logic Rule Operator 1. Parameter 13-42 Logic Rule Boolean 2. 	
[0]	DISABLED	Select this option to ignore parameter 13-44 Logic Rule Boolean 3.
[1]	AND	
[2]	OR	
[3]	AND NOT	
[4]	OR NOT	
[5]	NOT AND	
[6]	NOT OR	
[7]	NOT AND NOT	
[8]	NOT OR NOT	

13-44 Logic Rule Boolean 3		
Array [6]		
Option:	Function:	
	Select the 3 rd boolean (true or false) input for the selected logic rule. See parameter 13-40 Logic Rule Boolean 1 for further descriptions of options and their functions.	
[0]	False	
[1]	True	
[2]	Running	
[3]	In range	
[4]	On reference	
[5]	Torque limit	
[6]	Current Limit	
[7]	Out of current range	
[8]	Below I low	
[9]	Above I high	
[10]	Out of speed range	
[11]	Below speed low	
[12]	Above speed high	
[13]	Out of feedb. range	

13-44 Logic Rule Boolean 3		
Array [6]		
Option:	Function:	
[14]	Below feedb. low	
[15]	Above feedb. high	
[16]	Thermal warning	
[17]	Mains out of range	
[18]	Reversing	
[19]	Warning	
[20]	Alarm (trip)	
[21]	Alarm (trip lock)	
[22]	Comparator 0	
[23]	Comparator 1	
[24]	Comparator 2	
[25]	Comparator 3	
[26]	Logic rule 0	
[27]	Logic rule 1	
[28]	Logic rule 2	
[29]	Logic rule 3	
[30]	SL Time-out 0	
[31]	SL Time-out 1	
[32]	SL Time-out 2	
[33]	Digital input DI18	
[34]	Digital input DI19	
[35]	Digital input DI27	
[36]	Digital input DI29	
[37]	Digital input DI32	
[38]	Digital input DI33	
[39]	Start command	
[40]	Drive stopped	
[41]	Reset Trip	
[42]	Auto Reset Trip	
[43]	OK Key	
[44]	Reset Key	
[45]	Left Key	
[46]	Right Key	
[47]	Up Key	
[48]	Down Key	
[50]	Comparator 4	
[51]	Comparator 5	
[60]	Logic rule 4	
[61]	Logic rule 5	
[70]	SL Time-out 3	
[71]	SL Time-out 4	
[72]	SL Time-out 5	
[73]	SL Time-out 6	
[74]	SL Time-out 7	
[80]	No Flow	
[81]	Dry Pump	
[82]	End of Curve	
[83]	Broken Belt	

3.11.6 13-5* States

13-51 SL Controller Event		
Array [20]		
Option:	Function:	
		Select the boolean input (true or false) to define the smart logic controller event. See <i>parameter 13-02 Stop Event</i> for further descriptions of options and their functions.
[0]	False	
[1]	True	
[2]	Running	
[3]	In range	
[4]	On reference	
[5]	Torque limit	
[6]	Current Limit	
[7]	Out of current range	
[8]	Below I low	
[9]	Above I high	
[10]	Out of speed range	
[11]	Below speed low	
[12]	Above speed high	
[13]	Out of feedb. range	
[14]	Below feedb. low	
[15]	Above feedb. high	
[16]	Thermal warning	
[17]	Mains out of range	
[18]	Reversing	
[19]	Warning	
[20]	Alarm (trip)	
[21]	Alarm (trip lock)	
[22]	Comparator 0	
[23]	Comparator 1	
[24]	Comparator 2	
[25]	Comparator 3	
[26]	Logic rule 0	
[27]	Logic rule 1	
[28]	Logic rule 2	
[29]	Logic rule 3	
[30]	SL Time-out 0	
[31]	SL Time-out 1	
[32]	SL Time-out 2	
[33]	Digital input DI18	
[34]	Digital input DI19	
[35]	Digital input DI27	
[36]	Digital input DI29	
[37]	Digital input DI32	
[38]	Digital input DI33	
[39]	Start command	
[40]	Drive stopped	
[41]	Reset Trip	

13-51 SL Controller Event		
Array [20]		
Option:	Function:	
[42]	Auto Reset Trip	
[43]	OK Key	
[44]	Reset Key	
[45]	Left Key	
[46]	Right Key	
[47]	Up Key	
[48]	Down Key	
[50]	Comparator 4	
[51]	Comparator 5	
[60]	Logic rule 4	
[61]	Logic rule 5	
[70]	SL Time-out 3	
[71]	SL Time-out 4	
[72]	SL Time-out 5	
[73]	SL Time-out 6	
[74]	SL Time-out 7	
[80]	No Flow	
[81]	Dry Pump	
[82]	End of Curve	
[83]	Broken Belt	

13-52 SL Controller Action		
Array [20]		
Option:	Function:	
		Select the action corresponding to the SLC event. Actions are executed when the corresponding event (defined in <i>parameter 13-51 SL Controller Event</i>) is evaluated as true. The following actions are available for selection:
[0]	Disabled	
[1]	No action	
[2]	Select set-up 1	Changes the active set-up (<i>parameter 0-10 Active Set-up</i>) to 1.
[3]	Select set-up 2	Changes the active set-up (<i>parameter 0-10 Active Set-up</i>) to 2.
[4]	Select set-up 3	Changes the active set-up (<i>parameter 0-10 Active Set-up</i>) to 3.
[5]	Select set-up 4	Changes the active set-up (<i>parameter 0-10 Active Set-up</i>) to 4. If the set-up is changed, it merges with other set-up commands coming from either the digital inputs or via a fieldbus.
[10]	Select preset ref 0	Selects preset reference 0.
[11]	Select preset ref 1	Selects preset reference 1.
[12]	Select preset ref 2	Selects preset reference 2.

13-52 SL Controller Action		
Array [20]		
Option:	Function:	
[13] Select preset ref 3	Selects preset reference 3.	
[14] Select preset ref 4	Selects preset reference 4.	
[15] Select preset ref 5	Selects preset reference 5.	
[16] Select preset ref 6	Selects preset reference 6.	
[17] Select preset ref 7	Selects preset reference 7. If the active preset reference is changed, it merges with other preset reference commands coming from either the digital inputs or via a fieldbus.	
[18] Select ramp 1	Selects ramp 1.	
[19] Select ramp 2	Selects ramp 2.	
[22] Run	Issues a start command to the frequency converter.	
[23] Run reverse	Issues a start reverse command to the frequency converter.	
[24] Stop	Issues a stop command to the frequency converter.	
[26] DC Brake	Issues a DC stop command to the frequency converter.	
[27] Coast	The frequency converter coasts immediately. All stop commands including the coast command stop the SLC.	
[28] Freeze output	Freezes the output frequency of the frequency converter.	
[29] Start timer 0	Starts timer 0, see <i>parameter 13-20 SL Controller Timer</i> for further description.	
[30] Start timer 1	Starts timer 1, see <i>parameter 13-20 SL Controller Timer</i> for further description.	
[31] Start timer 2	Starts timer 2, see <i>parameter 13-20 SL Controller Timer</i> for further description.	
[32] Set digital out A low	Any output with digital output 1 selected is low (off).	
[33] Set digital out B low	Any output with digital output 2 selected is low (off).	
[34] Set digital out C low	Any output with digital output 3 selected is low (off).	
[35] Set digital out D low	Any output with digital output 4 selected is low (off).	
[36] Set digital out E low	Any output with digital output 5 selected is low (off).	
[37] Set digital out F low	Any output with digital output 6 selected is low (off).	

13-52 SL Controller Action		
Array [20]		
Option:	Function:	
[38] Set digital out A high	Any output with digital output 1 selected is high (closed).	
[39] Set digital out B high	Any output with digital output 2 selected is high (closed).	
[40] Set digital out C high	Any output with digital output 3 selected is high (closed).	
[41] Set digital out D high	Any output with digital output 4 selected is high (closed).	
[42] Set digital out E high	Any output with digital output 5 selected is high (closed).	
[43] Set digital out F high	Any output with digital output 6 selected is high (closed).	
[50] Night Action		
[51] Day Action		
[60] Reset Counter A	Resets counter A to 0.	
[61] Reset Counter B	Resets counter B to 0.	
[70] Start Timer 3	Starts timer 3, see <i>parameter 13-20 SL Controller Timer</i> for further description.	
[71] Start Timer 4	Starts timer 4, see <i>parameter 13-20 SL Controller Timer</i> for further description.	
[72] Start Timer 5	Starts timer 5, see <i>parameter 13-20 SL Controller Timer</i> for further description.	
[73] Start Timer 6	Starts timer 6, see <i>parameter 13-20 SL Controller Timer</i> for further description.	
[74] Start Timer 7	Starts timer 7, see <i>parameter 13-20 SL Controller Timer</i> for further description.	
[80] Sleep Mode	Starts the sleep mode.	

3.11.7 13-9* User-defined Alerts and Readouts

Parameters in this group allow the configuration of application-specific messages, warnings, and alarms. Use the following parameters to configure the frequency converter to show a message and perform an action when a specific event occurs:

- *Parameter 13-90 Alert Trigger* – the event that triggers the user-defined action and message.
- *Parameter 13-91 Alert Action* – the action that the frequency converter performs when the event defined in *parameter 13-90 Alert Trigger* occurs.
- *Parameter 13-92 Alert Text* – the text that the frequency converter shows in the display when the event defined in *parameter 13-90 Alert Trigger* occurs.

For example, consider the following use case:
 If there is an active signal on digital input 32, the frequency converter shows the message *Valve 5 open* in the display and ramps down to a stop.
 To achieve this configuration, make the following settings:

- Parameter 13-90 Alert Trigger = [37] Digital input DI32.
- Parameter 13-91 Alert Action = [5] Stop & warning.
- Parameter 13-92 Alert Text = Valve 5 open.

13-90 Alert Trigger		
Array [10] Select the event that triggers the user-defined action and message.		
Option:	Function:	
[0] *	False	
[1]	True	
[18]	Reversing	
[22]	Comparator 0	
[23]	Comparator 1	
[24]	Comparator 2	
[25]	Comparator 3	
[26]	Logic rule 0	
[27]	Logic rule 1	
[28]	Logic rule 2	
[29]	Logic rule 3	
[30]	SL Time-out 0	
[31]	SL Time-out 1	
[32]	SL Time-out 2	
[33]	Digital input DI18	
[34]	Digital input DI19	
[35]	Digital input DI27	
[36]	Digital input DI29	
[37]	Digital input DI32	
[38]	Digital input DI33	
[50]	Comparator 4	
[51]	Comparator 5	
[60]	Logic rule 4	
[61]	Logic rule 5	
[70]	SL Time-out 3	
[71]	SL Time-out 4	
[72]	SL Time-out 5	
[73]	SL Time-out 6	
[74]	SL Time-out 7	

13-91 Alert Action		
Array [10] Select the action that the frequency converter performs when the event defined in <i>parameter 13-90 Alert Trigger</i> occurs.		
Option:	Function:	
[0] *	Info	
[1]	Warning	
[2]	Freeze output	
[3]	Freeze output & warn	
[4]	Stop	

13-91 Alert Action		
Array [10] Select the action that the frequency converter performs when the event defined in <i>parameter 13-90 Alert Trigger</i> occurs.		
Option:	Function:	
[5]	Stop & warning	
[6]	Jogging	
[7]	Jogging & warning	
[8]	Max speed	
[9]	Max speed & warn	
[10]	Stop and trip	
[11]	Stop and trip w manual reset	
[12]	Trip	
[13]	Trip w manual reset	
[14]	Trip Lock	

13-92 Alert Text		
Array [10] Enter the text that the frequency converter shows in the display when the event defined in <i>parameter 13-90 Alert Trigger</i> occurs.		
Range:	Function:	
Size related*	[0 - 20]	

13-97 Alert Alarm Word		
Range:	Function:	
0*	[0 - 4294967295]	Shows the alarm word of a user-defined alarm in hex code.

13-98 Alert Warning Word		
Range:	Function:	
0*	[0 - 4294967295]	Shows the warning word of a user-defined alarm in hex code.

13-99 Alert Status Word		
Range:	Function:	
0*	[0 - 4294967295]	Shows the status word of a user-defined alarm in hex code.

3.12 Parameters: 14-** Special Functions

Parameter group for configuring special frequency converter functions.

3.12.1 14-0* Inverter Switching

14-00 Switching Pattern		
Option:	Function:	
		Select the switching pattern: 60° AVM or SFAVM.
[0] *	60 AVM	
[1]	SFAVM	

14-01 Switching Frequency		
Option:	Function:	
		Select the inverter switching frequency. Changing the switching frequency can help reduce acoustic noise from the motor.
		NOTICE The output frequency value of the frequency converter must never exceed 1/10 of the switching frequency. When the motor is running, adjust the switching frequency in <i>parameter 14-01 Switching Frequency</i> until the motor is as noiseless as possible. See also <i>parameter 14-00 Switching Pattern</i> . For information about derating, see the relevant <i>design guide</i> .
[0]	1.0 kHz	
[1]	1.5 kHz	
[2]	2.0 kHz	
[3]	2.5 kHz	
[4]	3.0 kHz	
[5]	3.5 kHz	
[6]	4.0 kHz	
[7]	5.0 kHz	
[8]	6.0 kHz	
[9]	7.0 kHz	
[10]	8.0 kHz	
[11]	10.0 kHz	
[12]	12.0kHz	
[13]	14.0 kHz	
[14]	16.0kHz	

14-03 Overmodulation		
Option:	Function:	
[0]	Off	Selects no overmodulation of the output voltage to avoid torque ripple on the motor shaft.
[1] *	On	The overmodulation function generates an extra voltage of up to 8% of U_{max} output voltage without overmodulation. This extra voltage results in an extra torque of 10–12% in the middle of the oversynchronous

14-03 Overmodulation		
Option:	Function:	
		range (from 0% at nominal speed, rising to approximately 12% at double nominal speed).

14-04 PWM Random		
Option:	Function:	
[0] *	Off	No change of the acoustic motor switching noise.
[1]	On	Select to reduce the acoustic noise from the motor.

3.12.2 14-1* Mains On/Off

Parameters for configuring mains failure monitoring and handling.

14-10 Mains Failure		
Option:	Function:	
		Select the function at which the frequency converter must act, when the threshold set in <i>parameter 14-11 Mains Voltage at Mains Fault</i> has been reached or a Mains Failure Inverse command is activated via 1 of the digital inputs (<i>parameter group 5-1* Digital Inputs</i>). Only selection [0] No function, [3] Coasting, or [6] Alarm is available when <i>parameter 1-10 Motor Construction</i> is set to [1] PM non-salient SPM.
[0] *	No function	The energy left in the capacitor bank is used to drive the motor, but is discharged.
[1]	Ctrl. ramp-down	The frequency converter performs a controlled ramp down. <i>Parameter 2-10 Brake Function</i> must be set to [0] Off.
[3]	Coasting	The inverter turns off and the capacitor bank backs up the control card. Backing up control card ensures a faster restart when mains is reconnected (at short power zags).
[4]	Kinetic back-up	The frequency converter rides through by controlling speed for generative operation of the motor utilising the moment of inertia of the system as long as sufficient energy is present.
[6]	Alarm	

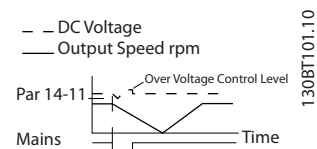

Illustration 3.37 Controlled Ramp Down - Short Mains Failure

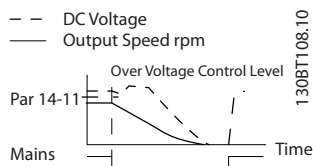

Illustration 3.38 Controlled Ramp Down, Longer Mains Failure

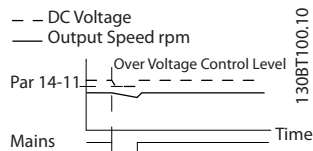

Illustration 3.39 Kinetic Back-up, Short Mains Failure

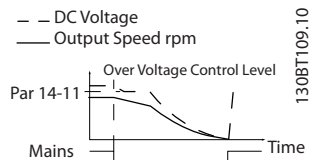

Illustration 3.40 Kinetic Back-up, Longer Mains Failure

14-11 Mains Voltage at Mains Fault		
Range:		Function:
Size related*	[180 - 600 V]	This parameter defines the threshold voltage at which the selected function in <i>parameter 14-10 Mains Failure</i> should be activated. The detection level is at a factor $\sqrt{2}$ of the value in this parameter.

14-12 Function at Mains Imbalance		
Option:	Function:	
		Operation under severe mains imbalance conditions reduces the lifetime of the motor. Conditions are considered severe if the motor is operated continuously near nominal load (for example a pump or fan running near full speed). When a severe mains imbalance is detected, select 1 of the available functions.
[0] *	Trip	Trips the frequency converter.
[1]	Warning	Issues a warning.
[2]	Disabled	No action.
[3]	Derate	Derates the frequency converter.

14-16 Kin. Backup Gain		
Range:		Function:
100 %*	[0 - 500 %]	Enter the kinetic back-up gain value in percent.

3.12.3 14-2* Trip Reset

Parameters for configuring auto reset handling, special trip handling, and control card self-test or initialization.

14-20 Reset Mode		
Option:	Function:	
		NOTICE Automatic reset is also active for resetting the Safe Torque Off function in firmware version earlier than 4.3. Select the reset function after tripping. Once reset, the frequency converter can be restarted.
[0]	Manual reset	Select this option to perform a reset via [Reset] or via the digital inputs.
[1]	Automatic reset x 1	Select [1]-[12] Automatic reset x1...x20 to perform between 1 and 20 automatic resets after tripping.
[2]	Automatic reset x 2	
[3] *	Automatic reset x 3	
[4]	Automatic reset x 4	
[5]	Automatic reset x 5	
[6]	Automatic reset x 6	
[7]	Automatic reset x 7	
[8]	Automatic reset x 8	
[9]	Automatic reset x 9	
[10]	Automatic reset x 10	
[11]	Automatic reset x 15	
[12]	Automatic reset x 20	
[13]	Infinite auto reset	Select this option for continuous resetting after tripping.

Application Tip:

If *parameter 14-20 Reset Mode* or *parameter 14-21 Automatic Restart Time* is set to auto reset after 30 s, this should be considered if a relay output is set to call for a service technician if an alarm occurs.

If *parameter 5-40 Function Relay* is set to [9] Alarm and *parameter 5-41 On Delay, Relay* to 40 s, the relay activates only at either a trip lock alarm or an alarm, which could be not auto reset. Only the relay output can be used for this. The digital outputs do not have the on-delay feature.

NOTICE

The motor may start without warning. If the specified number of automatic resets is reached within 10 minutes, the frequency converter enters [0] Manual reset mode. After the manual reset is performed, the setting of parameter 14-20 Reset Mode reverts to the original option. If the number of automatic resets is not reached within 10 minutes, or when a manual reset is performed, the internal automatic reset counter returns to 0.

14-21 Automatic Restart Time		
Range:	Function:	
60 s* [0 - 600 s]	Enter the time interval from trip to start of the automatic reset function. This parameter is active when parameter 14-20 Reset Mode is set to [1]-[13] Automatic reset.	

14-22 Operation Mode		
Option:	Function:	
		Use this parameter to specify normal operation, to perform tests, or to initialize all parameters except: <ul style="list-style-type: none"> Parameter 15-03 Power Up's. Parameter 15-04 Over Temp's. Parameter 15-05 Over Volt's. This function is active only when the power is cycled (power off/power on) to the frequency converter.
[0]	Normal operation	Normal operation of the frequency converter with the motor in the selected application.
[1]	Control card test	Tests the analog and digital inputs and outputs and the +10 V control voltage. The test requires a test connector with internal connections. <p>Use the following procedure for the control card test:</p> <ol style="list-style-type: none"> Select [1] Control card test. Disconnect the mains supply and wait for the light in the display to go out. Set switches S201 (A53) and S202 (A54)=ON/I. Insert the test plug (see Illustration 3.41). Connect to mains supply. Carry out various tests. The results are shown in the display and the frequency converter moves into an infinite loop. Parameter 14-22 Operation Mode is automatically set to [0] Normal

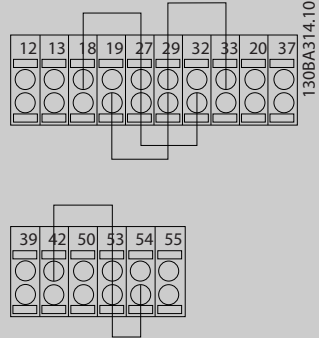
14-22 Operation Mode		
Option:	Function:	
		operation. Carry out a power cycle to start up in normal operation after a control card test. <p>If the test is OK LCP readout: Control card OK. Disconnect the mains supply and remove the test plug. The green LED on the control card lights up.</p> <p>If the test fails LCP readout: Control card I/O failure. Replace the frequency converter or control card. The red indicator light on the control card is turned on. To test the plugs, connect/group the following terminals as shown in Illustration 3.41:</p> <ul style="list-style-type: none"> (18, 27, and 32) (19, 29, and 33) (42, 53, and 54)  <p>Illustration 3.41 Wiring Control Card Test</p>
[2]	Initialisation	Resets all parameter values to default settings, except for: <ul style="list-style-type: none"> Parameter 15-03 Power Up's. Parameter 15-04 Over Temp's. Parameter 15-05 Over Volt's. The frequency converter resets during the next power-up. Parameter 14-22 Operation Mode also reverts to the default setting [0] Normal operation.
[3]	Boot mode	
[4]	Initialize all parameters	Select this option to reset all parameters (including bus and motor parameters) to default values.

14-25 Trip Delay at Torque Limit		
Range:	Function:	
60 s* [0 - 60 s]	Enter the torque limit trip delay in s. When the output torque reaches the torque limits (<i>parameter 4-16 Torque Limit Motor Mode</i> and <i>parameter 4-17 Torque Limit Generator Mode</i>), a warning is triggered. When the torque limit warning has been continuously present for the period specified in this parameter, the frequency converter trips. Disable the trip delay by setting the parameter to 60 s=OFF. Thermal frequency converter monitoring remains active.	

14-26 Trip Delay at Inverter Fault		
Range:	Function:	
Size related* [0 - 35 s]	When the frequency converter detects an overvoltage in the set time, trip is effected after the set time.	

14-28 Production Settings		
For service technicians only.		
Option:	Function:	
[0] *	No action	
[1]	Service reset	

14-29 Service Code		
Range:	Function:	
0* [-2147483647 - 2147483647]	Enter code 5000 to restore the 8 digit ordering number in <i>parameter 15-46 Frequency Converter Ordering No</i> after a power card exchange. The number should match the ordering number on the nameplate of the frequency converter.	

3.12.4 14-3* Current Limit Control

The frequency converter features an integral current limit controller which is activated when the motor current, and thus the torque, is higher than the torque limits set in *parameter 4-16 Torque Limit Motor Mode* and *parameter 4-17 Torque Limit Generator Mode*.

When the current limit is reached during motor operation or regenerative operation, the frequency converter tries to reduce torque below the preset torque limits as quickly as possible without losing control of the motor.

While the current control is active, the frequency converter can only be stopped by setting a digital input to [2] *Coast inverse* or [3] *Coast and reset inv.* Any signal on terminals 18–33 are not active until the frequency converter is no longer near the current limit.

By using a digital input set to [2] *Coast inverse* or [3] *Coast and reset inv.*, the motor does not use the ramp down time, since the frequency converter is coasted.

14-30 Current Lim Ctrl, Proportional Gain		
Range:	Function:	
100 %* [0 - 500 %]	Enter the proportional gain value for the current limit controller. Selection of a high value makes the controller react faster. Too high a setting leads to controller instability.	

14-31 Current Lim Ctrl, Integration Time		
Range:	Function:	
Size related* [0.002 - 2 s]	Controls the current limit control integration time. Setting it to a lower value makes it react faster. A setting too low leads to control instability.	

3.12.5 14-4* Energy Optimising

Parameters for adjusting the energy optimization level in both variable torque (VT) and automatic energy optimization (AEO) mode.

Automatic energy optimization is only active if *parameter 1-03 Torque Characteristics*, is set for either [2] *Auto Energy Optim. Compressor* or [3] *Auto Energy Optim. VT*.

14-40 VT Level		
Range:	Function:	
66 %* [40 - 90 %]	<p>NOTICE</p> <p>This parameter cannot be adjusted while the motor is running.</p> <p>NOTICE</p> <p>This parameter is not active when <i>parameter 1-10 Motor Construction</i> is set to [1] <i>PM non-salient SPM</i>.</p>	
	Enter the level of motor magnetization at low speed. Selection of a low value reduces energy loss in the motor, but also reduces load capability.	

14-41 AEO Minimum Magnetisation		
Range:	Function:	
Size related* [40 - 200 %]	<p>NOTICE</p> <p>This parameter is not active when <i>parameter 1-10 Motor Construction</i> is set to [1] <i>PM non-salient SPM</i>.</p>	
	Enter the minimum allowable magnetization for AEO. Selection of a low value reduces energy loss in the motor, but can also reduce resistance to sudden load changes.	

14-42 Minimum AEO Frequency		
Range:	Function:	
Size related*	[5 - 40 Hz]	<p>NOTICE</p> <p>This parameter is not active when <i>parameter 1-10 Motor Construction</i> is set to [1] <i>PM non-salient SPM</i>.</p> <p>Enter the minimum frequency at which the automatic energy optimization (AEO) is to be active.</p>

14-43 Motor Cosphi		
Range:	Function:	
Size related*	[0.40 - 0.95]	The Cos(phi) setpoint is automatically set for optimum AEO performance during AMA. This parameter should normally not be altered. However, in some situations it may be necessary to enter a new value to fine-tune.

3.12.6 14-5* Environment

NOTICE

Perform a power cycle after changing any of the parameters in *parameter group 14-5* Environment*.

These parameters help the frequency converter to operate under special environmental conditions.

14-50 RFI Filter		
Option:	Function:	
[0]	Off	Select [0] <i>Off</i> if the frequency converter is fed by an isolated mains source (IT mains). If a filter is used, select [0] <i>Off</i> during charging to prevent a high leakage current making the RCD switch. In this mode, the internal RFI filter capacitors between enclosure and the mains RFI filter circuit are cut out to reduce the ground capacity currents.
[1]	* On	Select [1] <i>On</i> to ensure that the frequency converter complies with EMC standards.

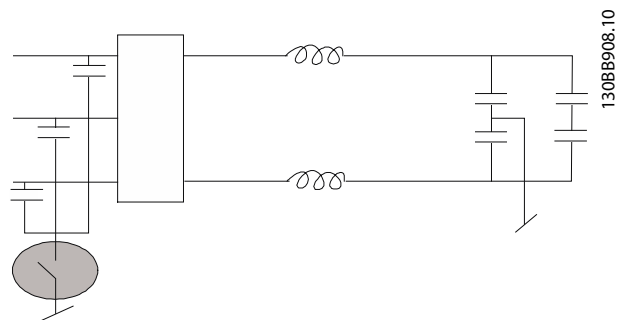

Illustration 3.42 RFI Filter

14-51 DC Link Compensation		
Option:	Function:	
		The rectified AC-DC voltage in the frequency converter's DC-link is associated with voltage ripples. These ripples can increase in magnitude with increased load. These ripples are undesirable because they can generate current and torque ripples. A compensation method is used to reduce these voltage ripples in the DC link. In general, DC-link compensation is recommended for most applications, but pay attention when operating in field weakening as it can generate speed oscillations at the motor shaft. In field weakening, turn off DC-link compensation.
[0]	Off	Disables DC-link compensation.
[1]	On	Enables DC-link compensation.

14-52 Fan Control		
Option:	Function:	
		Select the minimum speed of the main fan.
[0]	* Auto	Select [0] <i>Auto</i> to run the fan only when the internal temperature of the frequency converter is in the range 35 °C (95 °F) to approximately 55 °C (131 °F). The fan runs at low speed at 35 °C (95 °F) and at full speed at approximately 55 °C (131 °F).
[1]	On 50%	
[2]	On 75%	
[3]	On 100%	
[4]	Auto (Low temp env.)	

14-53 Fan Monitor		
Option:	Function:	
		Select the frequency converter action if a fan fault is detected.
[0]	Disabled	
[1]	* Warning	
[2]	Trip	

14-55 Output Filter		
Option:	Function:	
	<p>NOTICE This parameter cannot be adjusted while the motor is running.</p> <p>NOTICE Reset the frequency converter after selecting [2] <i>Sine-Wave Filter Fixed</i>.</p> <p>CAUTION OVERHEATING OF FREQUENCY CONVERTER Always set parameter 14-55 <i>Output Filter</i> to [2] <i>Sine-wave fixed</i> when using a sine-wave filter. Failure to do so can result in overheating of the frequency converter, which can result in personal injury and equipment damage.</p> <p>Select the type of output filter connected.</p>	
[0] *	No Filter	This is the default setting and should be used with dU/dt filters or high frequency common mode (HF-CM) filters.
[1]	Sine-Wave Filter	This setting is for backwards compatibility. It does not limit the range of the switching frequency.
[2]	Sine Wave Filter Fixed	This parameter sets a minimum allowed limit to the switching frequency and ensures that the filter is operated within the safe range of switching frequencies. Operation is possible with all control principles. The modulation pattern is set to SFAVM, which gives the lowest acoustic noise in the filter.

14-59 Actual Number of Inverter Units		
This parameter is only relevant for high-power frequency converters.		
Range:	Function:	
Size related*	[1 - 1]	Sets the actual number of operating inverter units.

3.12.7 14-6* Auto Derate

This group contains parameters for derating the frequency converter in case of high temperature.

14-60 Function at Over Temperature		
Option:	Function:	
	If either heat sink or control card temperature exceeds a factory-programmed temperature limit, a warning is activated. If the temperature increases further, select whether the frequency converter should trip (trip lock) or derate the output current.	

14-60 Function at Over Temperature		
Option:	Function:	
[0] *	Trip	The frequency converter trips (trip lock) and generate an alarm. Cycle power to reset the alarm. The motor restarts when the heat sink temperature has dropped below the alarm limit.
[1]	Derate	If the critical temperature is exceeded, the output current is reduced until the allowable temperature has been reached.

3

3.12.8 No Trip at Inverter Overload

In some pump systems, the frequency converter has not been sized properly to yield the current needed in all points of the operational flow-head characteristic. At these points, the pump needs a current higher than the rated current of the frequency converter. The frequency converter can yield 110% of the rated current continuously for 60 s. If still overloaded, the frequency converter normally trips (causing the pump to stop by coasting) and issues an alarm.

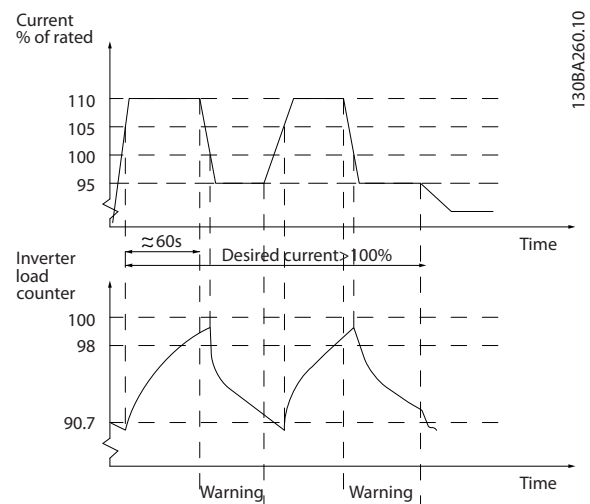

Illustration 3.43 Output Current in Overload Condition

If the pump is unable to run continuously with the demanded capacity, run it at reduced speed for a while.

Select *parameter 14-61 Function at Inverter Overload* to automatically reduce pump speed until the output current is below 100% of the rated current (set in *parameter 14-62 Inv. Overload Derate Current*). *Parameter 14-61 Function at Inverter Overload* is an alternative to letting the frequency converter trip.

The frequency converter estimates the load on the power section with an inverter load counter, which causes a warning at 98% and a reset of the warning at 90%. At the

3

value 100%, the frequency converter trips and issue an alarm.

Status for the counter can be read in *parameter 16-35 Inverter Thermal*.

If *parameter 14-61 Function at Inverter Overload* is set to [3] *Derate*, the pump speed is reduced when the counter exceeds 98%, and stays reduced until the counter has dropped below 90.7%.

If *parameter 14-62 Inv. Overload Derate Current* is set to for example 95%, a steady overload causes the pump speed to fluctuate between values corresponding to 110% and 95% of rated output current for the frequency converter.

14-61 Function at Inverter Overload		
Option:	Function:	
		Is used in case of steady overload beyond the thermal limits (110% for 60 s).
[0] *	Trip	Select [0] <i>Trip</i> to make the frequency converter trip and issue an alarm.
[1]	Derate	Reduces pump speed to decrease the load on the power section and allowing this to cool down.

14-62 Inv. Overload Derate Current		
Range:	Function:	
95 %*	[50 - 100 %]	Enter the current level (in % of rated output current for the frequency converter) when running with reduced pump speed after load on the frequency converter has exceeded the allowable limit (110% for 60 s).

14-80 Option Supplied by External 24VDC		
Option:	Function:	
		NOTICE This parameter is only changing function by performing a power cycle.
[0]	No	Select [0] <i>No</i> to use the frequency converter's 24 V DC supply.

14-80 Option Supplied by External 24VDC		
Option:	Function:	
[1] *	Yes	Select [1] <i>Yes</i> if a 24 V DC external supply is used to power the option. Inputs/outputs are galvanically isolated from the frequency converter when operated from an external supply.

14-89 Option Detection		
Selects the behavior of the frequency converter when a change in the option configuration is detected.		
Option:	Function:	
[0] *	Protect Option Config.	Freezes the current settings and prevents unwanted changes when missing or defective options are detected.
[1]	Enable Option Change	Changes frequency converter settings and is used when modifying the system configuration. This parameter setting returns to [0] <i>Protect Option Config.</i> after an option change.

14-90 Fault Level		
Use this parameter to customize fault levels.		
Option:	Function:	
[0]	Off	Use [0] <i>Off</i> with caution as it ignores all warnings and alarms for the selected source.
[1]	Warning	
[2]	Trip	Changing a fault level from default option [3] <i>Trip Lock</i> to [2] <i>Trip</i> leads to the automatic reset of the alarm. For alarms involving overcurrent, the frequency converter has a hardware protection that issues a 3 minute recovery after 2 consecutive overcurrent incidents. This hardware protection cannot be overruled.
[3]	Trip lock	
[4]	Trip w. delayed reset	

Failure	Alarm	Off	Warning	Trip	Trip w. delayed reset	Trip Lock
Inverter overloaded	9	X	D	-	-	-
Overcurrent	13	-	-	-	X	D
24 V supply low	47	X	-	-	-	D
Current limit	59	X	D	-	-	-
Locked rotor	99	-	-	X	-	D

Table 3.14 Selection of Action when Selected Alarm Appears

D means the default value. X means a possible selection.

3.13 Parameters: 15-*** Frequency Converter Information

Parameter group containing frequency converter information such as operating data, hardware configuration, and software versions.

3.13.1 15-0* Operating Data

15-00 Operating hours		
Range:	Function:	
0 h*	[0 - 2147483647 h]	View how many hours the frequency converter has run. The value is saved when the frequency converter is turned off.

15-01 Running Hours		
Range:	Function:	
0 h*	[0 - 2147483647 h]	View how many hours the motor has run. Reset the counter in <i>parameter 15-07 Reset Running Hours Counter</i> . The value is saved when the frequency converter is turned off.

15-02 kWh Counter		
Range:	Function:	
0 kWh*	[0 - 2147483647 kWh]	Registers the power consumption of the motor as an average value over 1 hour. Reset the counter in <i>parameter 15-06 Reset kWh Counter</i> .

15-03 Power Up's		
Range:	Function:	
0*	[0 - 2147483647]	View the number of times the frequency converter has been powered up.

15-04 Over Temp's		
Range:	Function:	
0*	[0 - 65535]	View the number of frequency converter temperature faults.

15-05 Over Volt's		
Range:	Function:	
0*	[0 - 65535]	View the number of frequency converter overvoltages.

15-06 Reset kWh Counter		
Option:	Function:	
[0] *	Do not reset	No reset of the kWh counter is required.
[1]	Reset counter	Press [OK] to reset the kWh counter to 0 (see <i>parameter 15-02 kWh Counter</i>).

15-07 Reset Running Hours Counter		
Option:	Function:	
[0] *	Do not reset	No reset of the running hours counter is required.
[1]	Reset counter	Select [1] <i>Reset counter</i> and press [OK] to reset the running hours counter (<i>parameter 15-01 Running Hours</i>) and <i>parameter 15-08 Number of Starts</i> to 0 (see also <i>parameter 15-01 Running Hours</i>).

15-08 Number of Starts		
Range:	Function:	
0*	[0 - 2147483647]	<p>NOTICE</p> <p>This parameter is reset when resetting <i>parameter 15-07 Reset Running Hours Counter</i>.</p> <p>This is a readout parameter only. The counter shows the number of starts and stops caused by a normal start/stop command and/or when entering/leaving sleep mode.</p>

3.13.2 15-1* Data Log Settings

The data log enables continuous logging of up to 4 data sources (*parameter 15-10 Logging Source*) at individual rates (*parameter 15-11 Logging Interval*). A trigger event (*parameter 15-12 Trigger Event*) and window (*parameter 15-14 Samples Before Trigger*) are used to start and stop the logging conditionally.

15-10 Logging Source		
Array [4]		
Option:	Function:	
		Select which variables are to be logged.
[0] *	None	
[1397]	Alert Alarm Word	
[1398]	Alert Warning Word	
[1399]	Alert Status Word	
[1600]	Control Word	
[1601]	Reference [Unit]	
[1602]	Reference [%]	
[1603]	Status Word	
[1610]	Power [kW]	
[1611]	Power [hp]	
[1612]	Motor Voltage	
[1613]	Frequency	
[1614]	Motor current	
[1616]	Torque [Nm]	
[1617]	Speed [RPM]	
[1618]	Motor Thermal	
[1624]	Calibrated Stator Resistance	

15-10 Logging Source		
Array [4]		
Option:	Function:	
[1630]	DC Link Voltage	
[1632]	Brake Energy /s	
[1633]	Brake Energy /2 min	
[1634]	Heatsink Temp.	
[1635]	Inverter Thermal	
[1650]	External Reference	
[1652]	Feedback[Unit]	
[1660]	Digital Input	
[1662]	Analog Input 53	
[1664]	Analog Input 54	
[1665]	Analog Output 42 [mA]	
[1666]	Digital Output [bin]	
[1690]	Alarm Word	
[1692]	Warning Word	
[1694]	Ext. Status Word	
[1695]	Ext. Status Word 2	
[1699]	Ext. Status Word 3	
[1860]	Digital Input 2	

15-11 Logging Interval		
Array [4]		
Range:	Function:	
Size related*	[0 - 0]	Enter the interval in ms between each sampling of the variables to be logged.

15-12 Trigger Event		
Option:	Function:	
		Selects the trigger event. When the trigger event occurs, a window is applied to freeze the log. The log then retains a specified percentage of samples before the occurrence of the trigger event (parameter 15-14 Samples Before Trigger).
[0] *	False	
[1]	True	
[2]	Running	
[3]	In range	
[4]	On reference	
[5]	Torque limit	
[6]	Current Limit	
[7]	Out of current range	
[8]	Below I low	
[9]	Above I high	
[10]	Out of speed range	
[11]	Below speed low	
[12]	Above speed high	
[13]	Out of feedb. range	
[14]	Below feedb. low	
[15]	Above feedb. high	

15-12 Trigger Event		
Option:	Function:	
[16]	Thermal warning	
[17]	Mains out of range	
[18]	Reversing	
[19]	Warning	
[20]	Alarm (trip)	
[21]	Alarm (trip lock)	
[22]	Comparator 0	
[23]	Comparator 1	
[24]	Comparator 2	
[25]	Comparator 3	
[26]	Logic rule 0	
[27]	Logic rule 1	
[28]	Logic rule 2	
[29]	Logic rule 3	
[33]	Digital input DI18	
[34]	Digital input DI19	
[35]	Digital input DI27	
[36]	Digital input DI29	
[37]	Digital input DI32	
[38]	Digital input DI33	
[50]	Comparator 4	
[51]	Comparator 5	
[60]	Logic rule 4	
[61]	Logic rule 5	

15-13 Logging Mode		
Option:	Function:	
[0] *	Log always	Select [0] Log always for continuous logging.
[1]	Log once on trigger	Select [1] Log once on trigger to conditionally start and stop logging using parameter 15-12 Trigger Event and parameter 15-14 Samples Before Trigger.

15-14 Samples Before Trigger		
Range:	Function:	
50*	[0 - 100]	Enter the percentage of all samples to be retained in the log before a trigger event occurs. See also parameter 15-12 Trigger Event and parameter 15-13 Logging Mode.

3.13.3 15-2* Historic Log

View up to 50 logged data items via the array parameters in this parameter group. Data is logged every time an event occurs (not to be confused with SLC events). Events in this context are defined as a change in 1 of the following areas:

- Digital inputs.
- Digital outputs.
- Warning word.
- Alarm word.

- Status word.
- Control word.
- Extended status word.

Events are logged with value and time stamp in ms. The time interval between 2 events depends on how often events occur (maximum once every scan time). Data logging is continuous, but if an alarm occurs, the log is saved and the values can be viewed on the display. This feature is useful, for example when carrying out service following a trip. View the historic log contained in this parameter via the serial communication port or via the display.

15-20 Historic Log: Event		
Array [50]		
Range:	Function:	
0*	[0 - 255]	View the event type of the logged events.

15-21 Historic Log: Value		
Array [50]		
Range:	Function:	
0*	[0 - 2147483647]	View the value of the logged event. Interpret the event values according to <i>Table 3.15</i> :
	Digital input	Decimal value. See <i>parameter 16-60 Digital Input</i> for description after converting to binary value.
	Digital output (not monitored in this SW release)	Decimal value. See <i>parameter 16-66 Digital Output [bin]</i> for a description after converting to binary value.
	Warning word	Decimal value. See <i>parameter 16-92 Warning Word</i> for a description.
	Alarm word	Decimal value. See <i>parameter 16-90 Alarm Word</i> for a description.
	Status word	Decimal value. See <i>parameter 16-03 Status Word</i> for a description after converting to binary value.
	Control word	Decimal value. See <i>parameter 16-00 Control Word</i> for a description.
	Extended status word	Decimal value. See <i>parameter 16-94 Ext. Status Word</i> for a description.
Table 3.15 Logged Events		

15-22 Historic Log: Time		
Array [50]		
Range:	Function:	
0 ms*	[0 - 2147483647 ms]	View the time at which the logged event occurred. Time is measured in ms since frequency converter start. The maximum value corresponds to approximately 24 days, which means that the count restarts at 0 after this time period.

15-23 Historic log: Date and Time		
Array [50]		
Range:	Function:	
Size related*	[0 - 0]	Array parameter; Date & Time 0–49: This parameter shows at which time the logged event occurred.

3.13.4 15-3* Alarm Log

Parameters in this group are array parameters, where up to 10 fault logs can be viewed. 0 is the most recent logged data, and 9 is the oldest. Fault codes, values, and time stamp can be viewed for all logged data.

15-30 Alarm Log: Error Code		
Array [10]		
Range:	Function:	
0*	[0 - 65535]	View the fault code and look up its meaning in <i>chapter 5 Troubleshooting</i> .

15-31 Alarm Log: Value		
Array [10]		
Range:	Function:	
0*	[-32767 - 32767]	View an extra description of the error. This parameter is mostly used in combination with <i>alarm 38, internal fault</i> .

15-32 Alarm Log: Time		
Array [10]		
Range:	Function:	
0 s*	[0 - 2147483647 s]	View the time when the logged event occurred. Time is measured in s from frequency converter start-up.

15-33 Alarm Log: Date and Time		
Array [10]		
Range:	Function:	
Size related*	[0 - 0]	Array parameter; Date & Time 0–9: This parameter shows at which time the logged event occurred.

15-34 Alarm Log: Status		
This parameter shows the status of the alarm:		
<ul style="list-style-type: none"> 0: Alarm inactive. 1: Alarm active. 		
Range:	Function:	
0*	[0 - 1]	

15-35 Alarm Log: Alarm Text		
Array [10]		
Range:	Function:	
0*	[0 - 32]	

3.13.5 15-4* Drive Identification

Parameters containing read-only information about the hardware and software configuration of the frequency converter.

15-40 FC Type		
Shows the FC type. The readout is identical to the frequency converter series power field of the type code definition, characters 1–6.		
Range:	Function:	
0*	[0 - 6]	

15-41 Power Section		
Shows the FC type. The readout is identical to the frequency converter series power field of the type code definition, characters 7–10.		
Range:	Function:	
0*	[0 - 20]	

15-42 Voltage		
Shows the FC type. The readout is identical to the frequency converter series power field of the type code definition, characters 11–12.		
Range:	Function:	
0*	[0 - 20]	

15-43 Software Version		
Range:	Function:	
0*	[0 - 5]	View the combined SW version (or package version) consisting of power SW and control SW.

15-44 Ordered Typecode String		
Range:	Function:	
0*	[0 - 40]	View the type code string used for reordering the frequency converter in its original configuration.

15-45 Actual Typecode String		
Range:	Function:	
0*	[0 - 40]	View the actual type code string.

15-46 Frequency Converter Ordering No		
Range:	Function:	
0*	[0 - 8]	View the 8-digit ordering number used for reordering the frequency converter in its original configuration. To restore the ordering number after the power card exchange, see <i>parameter 14-29 Service Code</i> .

15-47 Power Card Ordering No		
Range:	Function:	
0*	[0 - 8]	View the power card ordering number.

15-48 LCP Id No		
Range:	Function:	
0*	[0 - 20]	View the LCP ID number.

15-49 SW ID Control Card		
Range:	Function:	
0*	[0 - 20]	View the control card software version number.

15-50 SW ID Power Card		
Range:	Function:	
0*	[0 - 20]	View the power card software version number.

15-51 Frequency Converter Serial Number		
Range:	Function:	
0*	[0 - 10]	View the frequency converter serial number.

15-53 Power Card Serial Number		
Range:	Function:	
0*	[0 - 19]	View the power card serial number.

3.13.6 15-6* Option Ident.

This read-only parameter group contains information about the hardware and software configuration of the options installed in slots A, B, C0, and C1.

15-60 Option Mounted		
Array [8]		
Range:	Function:	
0*	[0 - 30]	Shows the type of the installed option.

15-61 Option SW Version		
Array [8]		
Range:	Function:	
0*	[0 - 20]	View the installed option software version.

15-62 Option Ordering No		
Array [8]		
Range:	Function:	
0*	[0 - 8]	Shows the ordering number for the installed options.

15-63 Option Serial No		
Array [8]		
Range:	Function:	
0*	[0 - 18]	View the installed option serial number.

15-70 Option in Slot A		
Range:	Function:	
0*	[0 - 30]	View the type code string for the option installed in slot A, and a translation of the type code string. For example, type code string AX means no option.

15-71 Slot A Option SW Version		
Range:	Function:	
0*	[0 - 20]	View the software version for the option installed in slot A.

15-72 Option in Slot B		
Range:	Function:	
0*	[0 - 30]	View the type code string for the option installed in slot B, and a translation of the type code string. For example, for type code string BX, the translation is No option.

15-73 Slot B Option SW Version		
Range:	Function:	
0*	[0 - 20]	View the software version for the option installed in slot B.

15-74 Option in Slot C0/E0		
Range:	Function:	
0*	[0 - 30]	View the type code string for the option installed in slot C, and a translation of the type code string. For example, type code string CXXXX means no option.

15-75 Slot C0/E0 Option SW Version		
Range:	Function:	
0*	[0 - 20]	View the software version for the option installed in slot C.

15-76 Option in Slot C1/E1		
Range:	Function:	
0*	[0 - 30]	Shows the typecode string for the options (CXXXX if there is no option).

15-77 Slot C1/E1 Option SW Version		
Range:	Function:	
0*	[0 - 20]	Software version for the installed option in option slot C.

15-80 Fan Running Hours		
Range:	Function:	
0 h*	[0 - 2147483647 h]	View how many hours the heat sink fan has run (increments for every hour). The value is saved when the frequency converter is turned off.

15-81 Preset Fan Running Hours		
Range:	Function:	
0 h*	[0 - 99999 h]	Enter the preset fan running hours counter, see <i>parameter 15-80 Fan Running Hours</i> . This parameter cannot be selected via the serial port, RS485.

3.13.7 15-9* Parameter Info

15-92 Defined Parameters		
Range:	Function:	
0*	[0 - 9999]	View a list of all defined parameters in the frequency converter. The list ends with 0.

15-93 Modified Parameters		
Range:	Function:	
0*	[0 - 9999]	View a list of the parameters that have been changed from their default setting. The list ends with 0. Changes may not be visible until up to 30 s after implementation.

15-99 Parameter Metadata		
Array [30]		
Range:	Function:	
0*	[0 - 9999]	This parameter contains data used by the MCT 10 Set-up Software tool.

3.14 Parameters: 16-** Data Readouts

3.14.1 16-0* General Status

16-00 Control Word		
Range:	Function:	
0*	[0 - 65535]	View the control word sent from the frequency converter via the serial communication port in hex code.

16-01 Reference [Unit]		
Range:	Function:	
0 ReferenceFeed-backUnit*	[-999999 - 999999 ReferenceFeed-backUnit]	View the present reference value applied on impulse or analog basis in the unit resulting from the configuration selected in <i>parameter 1-00 Configuration Mode</i> (Hz, Nm, or RPM).

16-02 Reference [%]		
Range:	Function:	
0 %*	[-200 - 200 %]	View the total reference. The total reference is the sum of digital, analog, preset, bus, and freeze references, plus catch up and slow down.

16-03 Status Word		
Range:	Function:	
0*	[0 - 65535]	View the status word sent from the frequency converter via the serial communication port in hex code.

16-05 Main Actual Value [%]		
Range:	Function:	
0 %*	[-100 - 100 %]	View the 2-byte word sent with the status word to the fieldbus master reporting the main actual value.

16-09 Custom Readout		
Range:	Function:	
0 CustomReadoutUnit*	[-999999.99 - 999999.99 CustomReadoutUnit]	View the user-defined readouts as defined in <i>parameter 0-30 Custom Readout Unit</i> , <i>parameter 0-31 Custom Readout Min Value</i> , and <i>parameter 0-32 Custom Readout Max Value</i> .

3.14.2 16-1* Motor Status

16-10 Power [kW]		
Range:	Function:	
0 kW*	[0 - 1000 kW]	Shows motor power in kW. The value shown is calculated based on the actual motor voltage and motor current. The value is filtered, and therefore approximately 1.3 s may pass from when an input value changes to when the data readout values change. The resolution of readout value on fieldbus is in 10 W steps.

16-11 Power [hp]		
Range:	Function:	
0 hp*	[0 - 1000 hp]	View the motor power in hp. The value shown is calculated based on the actual motor voltage and motor current. The value is filtered, and therefore approximately 1.3 ms may pass from when an input value changes to when the data readout values change.

16-12 Motor Voltage		
Range:	Function:	
0 V*	[0 - 6000 V]	View the motor voltage, a calculated value used for controlling the motor.

16-13 Frequency		
Range:	Function:	
0 Hz*	[0 - 6500 Hz]	View the motor frequency, without resonance damping.

16-14 Motor current		
Range:	Function:	
0 A*	[0 - 1856 A]	View the motor current measured as an average value, I_{RMS} . The value is filtered, and thus approximately 1.3 s may pass from when an input value changes to when the data readout values change.

16-15 Frequency [%]		
Range:	Function:	
0 %*	[-100 - 100 %]	View a 2-byte word reporting the actual motor frequency (without resonance damping) as a percentage (scale 0000–4000 hex) of <i>parameter 4-19 Max Output Frequency</i> . Set <i>parameter 9-16 PCD Read Configuration</i> index 1 to send it with the status word instead of the MAV.

16-16 Torque [Nm]		
Range:		Function:
0 Nm*	[-3000 - 3000 Nm]	View the torque value with sign, applied to the motor shaft. Linearity is not exact between 110% motor current and torque in relation to the rated torque. Some motors supply more than 160% torque. Therefore, the minimum and the maximum values depend on the maximum motor current as well as the motor used. The value is filtered, and thus approximately 1.3 s may pass from when an input changes value to when the data readout values change.

16-17 Speed [RPM]		
Range:		Function:
0 RPM*	[-30000 - 30000 RPM]	View the actual motor RPM.

16-18 Motor Thermal		
Range:		Function:
0 %*	[0 - 100 %]	View the calculated thermal load on the motor. The cutout limit is 100%. The basis for calculation is the ETR function selected in <i>parameter 1-90 Motor Thermal Protection</i> .

16-22 Torque [%]		
Range:		Function:
0 %*	[-200 - 200 %]	This is a readout parameter only. Shows the actual torque yielded in percentage of the rated torque, based on the setting of the motor size and rated speed in <i>parameter 1-20 Motor Power [kW]</i> or <i>parameter 1-21 Motor Power [HP]</i> , and <i>parameter 1-25 Motor Nominal Speed</i> . This is the value monitored by the broken-belt function set in <i>parameter group 22-6* Broken Belt Detection</i> .

16-24 Calibrated Stator Resistance		
Range:		Function:
0.0000 Ohm*	[0.0000 - 100.0000 Ohm]	Shows the calibrated stator resistance.

3.14.3 16-3* Drive Status

16-30 DC Link Voltage		
Range:		Function:
0 V*	[0 - 10000 V]	View a measured value. The value is filtered with a 30 ms time constant.

16-31 System Temp.		
Shows the highest internal system temperature.		
Range:		Function:
0 °C*	[-128 - 127 °C]	

16-32 Brake Energy /s		
Range:		Function:
0 kW*	[0 - 675000 kW]	View the brake power transmitted to an external brake resistor, stated as an instant value.

16-33 Brake Energy /2 min		
Range:		Function:
0 kW*	[0 - 500 kW]	View the brake power transmitted to an external brake resistor.

16-34 Heatsink Temp.		
Range:		Function:
0 °C*	[0 - 255 °C]	View the frequency converter heat sink temperature. The cutout limit is 90 ±5 °C (194 ±9 °F), and the motor cuts back in at 60 ±5 °C (140 ±9 °F).

16-35 Inverter Thermal		
Range:		Function:
0 %*	[0 - 100 %]	View the thermal load on the inverter. The cutout limit is 100%.

16-36 Inv. Nom. Current		
Range:		Function:
Size related*	[0.01 - 10000 A]	View the inverter nominal current, which should match the nameplate data on the connected motor. The data is used for calculation of torque, motor overload protection, and so on.

16-37 Inv. Max. Current		
Range:		Function:
Size related*	[0.01 - 10000 A]	View the inverter maximum current, which should match the nameplate data on the connected motor. The data is used for calculation of torque, motor overload protection, and so on.

16-38 SL Controller State		
Range:		Function:
0*	[0 - 100]	View the state of the event under execution by the SL controller.

16-39 Control Card Temp.		
Range:		Function:
0 °C*	[0 - 100 °C]	View the temperature on the control card, stated in °C.

16-40 Logging Buffer Full		
Option:		Function:
		View whether the logging buffer is full (see chapter 3.13.2 15-1* Data Log Settings). The logging buffer is never full when parameter 15-13 Logging Mode is set to [0] Log always.
[0] *	No	
[1]	Yes	

16-41 LCP Bottom Statusline		
Range:		Function:
0*	[0 - 50]	

16-49 Current Fault Source		
Range:		Function:
0*	[0 - 8]	The value indicates source of current fault, including: <ul style="list-style-type: none"> • Short circuit. • Overcurrent. • Imbalance of supply voltage (from left): 1 – 4 – inverter, 5–8 – rectifier, 0 – no fault recorded.

After a short circuit alarm (I_{max2}), or overcurrent alarm (I_{max1}), or imbalance of supply voltage, this contains the power card number associated with the alarm. It only holds 1 number indicating the highest priority power card number (master first). The value persists on power cycle, but if a new alarm occurs it is overwritten by the new power card number (even if it is a lower priority number). The value is only cleared when the alarm log is cleared (that is a 3-finger reset would reset the readout to 0).

3.14.4 16-5* Ref. & Feedb.

16-50 External Reference		
Range:		Function:
0*	[-200 - 200]	View the total reference, the sum of digital, analog, preset, fieldbus, and freeze references, plus catch up and slow down.

16-52 Feedback[Unit]		
Range:		Function:
0 ProcessCtrlUnit*	[-999999.999 - 999999.999 ProcessCtrlUnit]	View value of resulting feedback value after processing of feedback 1-3, see: <ul style="list-style-type: none"> • Parameter 16-54 Feedback 1 [Unit]. • Parameter 16-55 Feedback 2 [Unit]. • Parameter 16-56 Feedback 3 [Unit]. in the feedback manager.

16-52 Feedback[Unit]		
Range:		Function:
		See parameter group 20-0* Feedback. The value is limited by settings in parameter 3-02 Minimum Reference and parameter 3-03 Maximum Reference. Units as set in parameter 20-12 Reference/ Feedback Unit.

16-53 Digi Pot Reference		
Range:		Function:
0*	[-200 - 200]	View the contribution of the digital potentiometer to the actual reference.

16-54 Feedback 1 [Unit]		
Range:		Function:
0 ProcessCtrlUnit*	[-999999.999 - 999999.999 ProcessCtrlUnit]	View value of feedback 1, see parameter group 20-0* Feedback. Set the unit in parameter 20-12 Reference/ Feedback Unit.

16-55 Feedback 2 [Unit]		
Range:		Function:
0 ProcessCtrlUnit*	[-999999.999 - 999999.999 ProcessCtrlUnit]	View value of feedback 2, see parameter group 20-0* Feedback. Set the unit in parameter 20-12 Reference/ Feedback Unit.

16-56 Feedback 3 [Unit]		
Range:		Function:
0 ProcessCtrlUnit*	[-999999.999 - 999999.999 ProcessCtrlUnit]	View value of feedback 3, see parameter group 20-0* Feedback. Set the unit in parameter 20-12 Reference/ Feedback Unit.

3.14.5 16-6* Inputs and Outputs

16-60 Digital Input	
Range:	Function:
0* [0 - 65535]	View the signal states from the active digital inputs. Example: Input 18 corresponds to bit number 5, 0 = no signal, 1 = connected signal. Bit 6 works in the opposite way, on = 0, off = 1 (Safe Torque Off input).
Bit 0	Digital input terminal 33.
Bit 1	Digital input terminal 32.
Bit 2	Digital input terminal 29.
Bit 3	Digital input terminal 27.
Bit 4	Digital input terminal 19.
Bit 5	Digital input terminal 18.
Bit 6	Digital input terminal 37.
Bit 7	Digital input VLT® General Purpose I/O MCB 101 terminal X30/4.
Bit 8	Digital input VLT® General Purpose I/O MCB 101 terminal X30/3.
Bit 9	Digital input VLT® General Purpose I/O MCB 101 terminal X30/2.
Bit 10-63	Reserved for future terminals.

Table 3.16 Active Digital Inputs

Illustration 3.44 Relay Settings

16-61 Terminal 53 Switch Setting	
Option:	Function:
	View the setting of input terminal 53.
[0] *	Current
[1]	Voltage

16-62 Analog Input 53	
Range:	Function:
0* [-20 - 20]	View the actual value at input 53.

16-63 Terminal 54 Switch Setting	
Option:	Function:
	View the setting of input terminal 54.

16-63 Terminal 54 Switch Setting	
Option:	Function:
[0] *	Current
[1]	Voltage

16-64 Analog Input 54	
Range:	Function:
0* [-20 - 20]	View the actual value at input 54.

16-65 Analog Output 42 [mA]	
Range:	Function:
0* [0 - 30]	View the actual value at output 42 in mA. The value shown reflects the selection in parameter 6-50 Terminal 42 Output.

16-66 Digital Output [bin]	
Range:	Function:
0* [0 - 15]	View the binary value of all digital outputs.

16-67 Pulse Input #29 [Hz]	
Range:	Function:
0* [0 - 130000]	View the actual frequency rate on terminal 29.

16-68 Pulse Input #33 [Hz]	
Range:	Function:
0* [0 - 130000]	View the actual value of the frequency applied at terminal 33 as an impulse input.

16-69 Pulse Output #27 [Hz]	
Range:	Function:
0* [0 - 40000]	View the actual value of impulses applied to terminal 27 in digital output mode.

16-70 Pulse Output #29 [Hz]	
Range:	Function:
0* [0 - 40000]	View the actual value of pulses to terminal 29 in digital output mode.

16-71 Relay Output [bin]	
Range:	Function:
0* [0 - 511]	View the settings of all relays.

Illustration 3.45 Relay Settings

16-72 Counter A		
Range:	Function:	
0* [-2147483648 - 2147483647]	View the present value of counter A. Counters are useful as comparator operands, see <i>parameter 13-10 Comparator Operand</i> . Reset or change the value either via digital inputs (<i>parameter group 5-1* Digital Inputs</i>) or by using an SLC action (<i>parameter 13-52 SL Controller Action</i>).	

16-73 Counter B		
Range:	Function:	
0* [-2147483648 - 2147483647]	View the present value of counter B. Counters are useful as comparator operands (<i>parameter 13-10 Comparator Operand</i>). Reset or change the value either via digital inputs (<i>parameter group 5-1* Digital Inputs</i>) or by using an SLC action (<i>parameter 13-52 SL Controller Action</i>).	

16-75 Analog In X30/11		
Range:	Function:	
0* [-20 - 20]	View the actual value at input X30/11 of VLT® General Purpose I/O MCB 101.	

16-76 Analog In X30/12		
Range:	Function:	
0* [-20 - 20]	View the actual value at input X30/12 of VLT® General Purpose I/O MCB 101.	

16-77 Analog Out X30/8 [mA]		
Range:	Function:	
0* [0 - 30]	View the actual value at input X30/8 in mA.	

16-78 Analog Out X45/1 [mA]		
Range:	Function:	
0* [0 - 30]	Shows the actual output value at terminal X45/1. The value shown reflects the selection in <i>parameter 6-70 Terminal X45/1 Output</i> .	

16-79 Analog Out X45/3 [mA]		
Range:	Function:	
0* [0 - 30]	Shows the actual output value at terminal X45/3. The value shown reflects the selection in <i>parameter 6-80 Terminal X45/3 Output</i> .	

3.14.6 16-8* Fieldbus & FC Port

Parameters for reporting the bus references and control words.

16-80 Fieldbus CTW 1		
Range:	Function:	
0* [0 - 65535]	View the 2-byte control word (CTW) received from the fieldbus master. Interpretation of the control word depends on the fieldbus option installed and the control word profile selected in <i>parameter 8-10 Control Profile</i> . For more information, refer to the relevant fieldbus manual.	

16-82 Fieldbus REF 1		
Range:	Function:	
0* [-200 - 200]	View the 2-byte word sent with the control word from the fieldbus master to set the reference value. For more information, refer to the relevant fieldbus manual.	

16-84 Comm. Option STW		
Range:	Function:	
0* [0 - 65535]	Shows the status word of the extended fieldbus communication option. For more information, refer to the relevant fieldbus manual.	

16-85 FC Port CTW 1		
Range:	Function:	
0* [0 - 65535]	View the 2-byte control word (CTW) received from the fieldbus master. Interpretation of the control word depends on the fieldbus option installed and the control word profile selected in <i>parameter 8-10 Control Profile</i> .	

16-86 FC Port REF 1		
Range:	Function:	
0* [-200 - 200]	View the 2-byte status word (STW) sent to the fieldbus master. Interpretation of the status word depends on the fieldbus option installed and the control word profile selected in <i>parameter 8-10 Control Profile</i> .	

3.14.7 16-9* Diagnosis Readouts

NOTICE

When using MCT 10 Set-up Software, the readout parameters can only be read online, that is as the actual status. This means that the status is not stored in the MCT 10 Set-up Software file.

16-90 Alarm Word		
Range:	Function:	
0* [0 - 4294967295]	Shows the alarm word sent via the serial communication port in hex code.	

16-91 Alarm Word 2		
Range:	Function:	
0* [0 - 4294967295]	View the alarm word 2 sent via the serial communication port in hex code.	

16-92 Warning Word		
Range:	Function:	
0* [0 - 4294967295]	Shows the warning word sent via the serial communication port in hex code.	

16-93 Warning Word 2		
Range:	Function:	
0* [0 - 4294967295]	View the warning word 2 sent via the serial communication port in hex code.	

16-94 Ext. Status Word		
Range:	Function:	
0* [0 - 4294967295]	Returns the extended status word sent via the serial communication port in hex code.	

16-95 Ext. Status Word 2		
Range:	Function:	
0* [0 - 4294967295]	Returns the extended warning word 2 sent via the serial communication port in hex code.	

16-96 Maintenance Word		
Range:	Function:	
0* [0 - 4294967295]	Readout of the preventive maintenance word. The bits reflect the status for the programmed preventive maintenance events in <i>parameter group 23-1* Maintenance</i> . 13 bits show combinations of all the possible items: <ul style="list-style-type: none"> • Bit 0: Motor bearings. • Bit 1: Pump bearings. • Bit 2: Fan bearings. • Bit 3: Valve. • Bit 4: Pressure transmitter. 	

16-96 Maintenance Word					
Range:		Function:			
		<ul style="list-style-type: none"> • Bit 5: Flow transmitter. • Bit 6: Temperature transmitter. • Bit 7: Pump seals. • Bit 8: Fan belt. • Bit 9: Filter. • Bit 10: Frequency converter cooling fan. • Bit 11: Frequency converter system health check. • Bit 12: Warranty. • Bit 13: Maintenance Text 0. • Bit 14: Maintenance Text 1. • Bit 15: Maintenance Text 2. • Bit 16: Maintenance Text 3. • Bit 17: Maintenance Text 4. 			
Position	4⇒	Valve	Fan bearings	Pump bearings	Motor bearings
Position	3⇒	Pump seals	Temperature transmitter	Flow transmitter	Pressure transmitter
Position	2⇒	Drive system health check	Drive cooling fan	Filter	Fan belt
Position	1⇒	-	-	-	Warranty
	0 _{hex}	-	-	-	-
	1 _{hex}	-	-	-	+
	2 _{hex}	-	-	+	-
	3 _{hex}	-	-	+	+
	4 _{hex}	-	+	-	-
	5 _{hex}	-	+	-	+
	6 _{hex}	-	+	+	-
	7 _{hex}	-	+	+	+
	8 _{hex}	+	-	-	-
	9 _{hex}	+	-	-	+
	A _{hex}	+	-	+	-
	B _{hex}	+	-	+	+
	C _{hex}	+	+	-	-
	D _{hex}	+	+	-	+
	E _{hex}	+	+	+	-
	F _{hex}	+	+	+	+

Table 3.17 Maintenance Word

Example:
The preventive maintenance word shows 040A_{hex}.

3

16-96 Maintenance Word					
Range:	Function:				
	Position	1	2	3	4
	Hex value	0	4	0	A
<p>Table 3.18 Example</p> <p>The first digit 0 indicates that no items from the 4th row require maintenance.</p> <p>The 2nd digit 4 refers to the 3rd row indicating that the frequency converter cooling fan requires maintenance.</p> <p>The 3rd digit 0 indicates that no items from the 2nd row require maintenance.</p> <p>The 4th digit A refers to the top row indicating that the valve and the pump bearings require maintenance.</p>					

16-99 Ext. Status Word 3	
Returns the extended warning word 3 sent via the serial communication port in hex code.	
Range:	Function:
0*	[0 - 4294967295]

3.15 Parameters: 18-*** Data Readouts 2

3.15.1 18-0* Maintenance Log

This group contains the last 10 preventive maintenance events. Maintenance log 0 is the latest and maintenance log 9 the oldest.

By selecting 1 of the logs and pressing [OK], the maintenance item, action, and time of the occurrence are shown in *parameter 18-00 Maintenance Log: Item* – *parameter 18-03 Maintenance Log: Date and Time*.

The alarm log key allows access to both alarm log and maintenance log.

18-00 Maintenance Log: Item		
Array [10] For details about a fault code, refer to the <i>design guide</i> .		
Range:		Function:
0*	[0 - 255]	Find the meaning of the maintenance item in <i>parameter 23-10 Maintenance Item</i> .

18-01 Maintenance Log: Action		
Array [10] For details about a fault code, refer to the <i>design guide</i> .		
Range:		Function:
0*	[0 - 255]	Locate the meaning of the maintenance item in the description of <i>parameter 23-11 Maintenance Action</i> .

18-02 Maintenance Log: Time		
Array [10]		
Range:		Function:
0 s*	[0 - 2147483647 s]	Shows when the logged event occurred. Time is measured in s since last power-up.

18-03 Maintenance Log: Date and Time		
Array [10]		
Range:		Function:
Size related*	[0 - 0]	Shows when the logged event occurred. NOTICE This requires that the date and time is programmed in <i>parameter 0-70 Set Date and Time</i> . Date format depends on the setting in <i>parameter 0-71 Date Format</i> , while the time format depends on the setting in <i>parameter 0-72 Time Format</i> .

18-03 Maintenance Log: Date and Time		
Array [10]		
Range:		Function:
		NOTICE The frequency converter has no back-up of the clock function, and the set date/time resets to default (2000-01-01 00:00) after a power-down unless a real-time clock module with back-up is installed. In <i>parameter 0-79 Clock Fault</i> it is possible to program a warning in case the clock has not been set properly, for example after a power-down. Incorrect setting of the clock affects the time stamps for the maintenance events.

NOTICE

When mounting a VLT® Analog I/O MCB 109 option card, a battery back-up of date and time is included.

3.15.2 18-3* Analog I/O

Parameters for reporting the digital and analog I/O ports.

18-30 Analog Input X42/1		
Range:		Function:
0*	[-20 - 20]	Readout of the value of the signal applied to terminal X42/1 on the analog I/O card. The units of the value shown in the LCP correspond to the mode selected in <i>parameter 26-00 Terminal X42/1 Mode</i> .

18-31 Analog Input X42/3		
Range:		Function:
0*	[-20 - 20]	Readout of the value of the signal applied to terminal X42/3 on the analog I/O card. The units of the value shown in the LCP correspond to the mode selected in <i>parameter 26-01 Terminal X42/3 Mode</i> .

18-32 Analog Input X42/5		
Range:		Function:
0*	[-20 - 20]	Readout of the value of the signal applied to terminal X42/5 on the analog I/O card. The units of the value shown in the LCP correspond to the mode selected in <i>parameter 26-02 Terminal X42/5 Mode</i> .

18-33 Analog Out X42/7 [V]		
Range:	Function:	
0*	[0 - 30]	Readout of the value of the signal applied to terminal X42/7 on the analog I/O card. The value shown reflects the selection in <i>parameter 26-40 Terminal X42/7 Output</i> .

18-34 Analog Out X42/9 [V]		
Range:	Function:	
0*	[0 - 30]	Readout of the value of the signal applied to terminal X42/9 on the analog I/O card. The value shown reflects the selection in <i>parameter 26-50 Terminal X42/9 Output</i> .

18-35 Analog Out X42/11 [V]		
Range:	Function:	
0*	[0 - 30]	Readout of the value of the signal applied to terminal X42/11 on the analog I/O card. The value shown reflects the selection in <i>parameter 26-60 Terminal X42/11 Output</i> .

18-57 Air Pressure to Flow Air Flow		
Shows the air flow calculated using the measured pressure difference.		
Range:	Function:	
0 AirPresToFlowUnit*	[0 - 999999 AirPresTo-FlowUnit]	

18-70 Mains Voltage		
Shows the mains line-to-line voltage measurements. The values are RMS.		
Array values:		
<ul style="list-style-type: none"> 0: Average. 1: Phase R to S. 2: Phase S to T. 3: Phase T to R. 		
Range:	Function:	
0 V*	[0 - 1000 V]	

18-71 Mains Frequency		
Shows the mains frequency.		
Range:	Function:	
0 Hz*	[-100 - 100 Hz]	

18-72 Mains Imbalance		
Shows the maximum measured imbalance for the 3 mains line-to-line measurements.		
Range:	Function:	
0 %*	[0 - 100 %]	

18-75 Rectifier DC Volt.		
Shows the DC voltage measurement from the rectifier module.		
Range:	Function:	
0 V*	[0 - 10000 V]	

3.15.3 18-6* Inputs & Outputs 2

This group contains information about digital and analog I/O ports.

18-60 Digital Input 2		
Range:	Function:	
0*	[0 - 65535]	Shows the signal states from the active digital inputs. <ul style="list-style-type: none"> 0 = No signal. 1 = Connected signal.

3.15.4 18-7* Rectifier Status

This parameter group contains read-only parameters related to the rectifier section.

3.16 Parameters: 20-** FC Closed Loop

This parameter group is used for configuring the closed-loop PID controller that controls the output frequency of the frequency converter.

3.16.1 20-0* Feedback

This parameter group is used to configure the feedback signal for the frequency converter's closed-loop PID controller. Whether the frequency converter is in closed-loop mode or open-loop mode, the feedback signals can also be shown on the frequency converter's display, be used to control a frequency converter analog output, and be transmitted over various serial communication protocols.

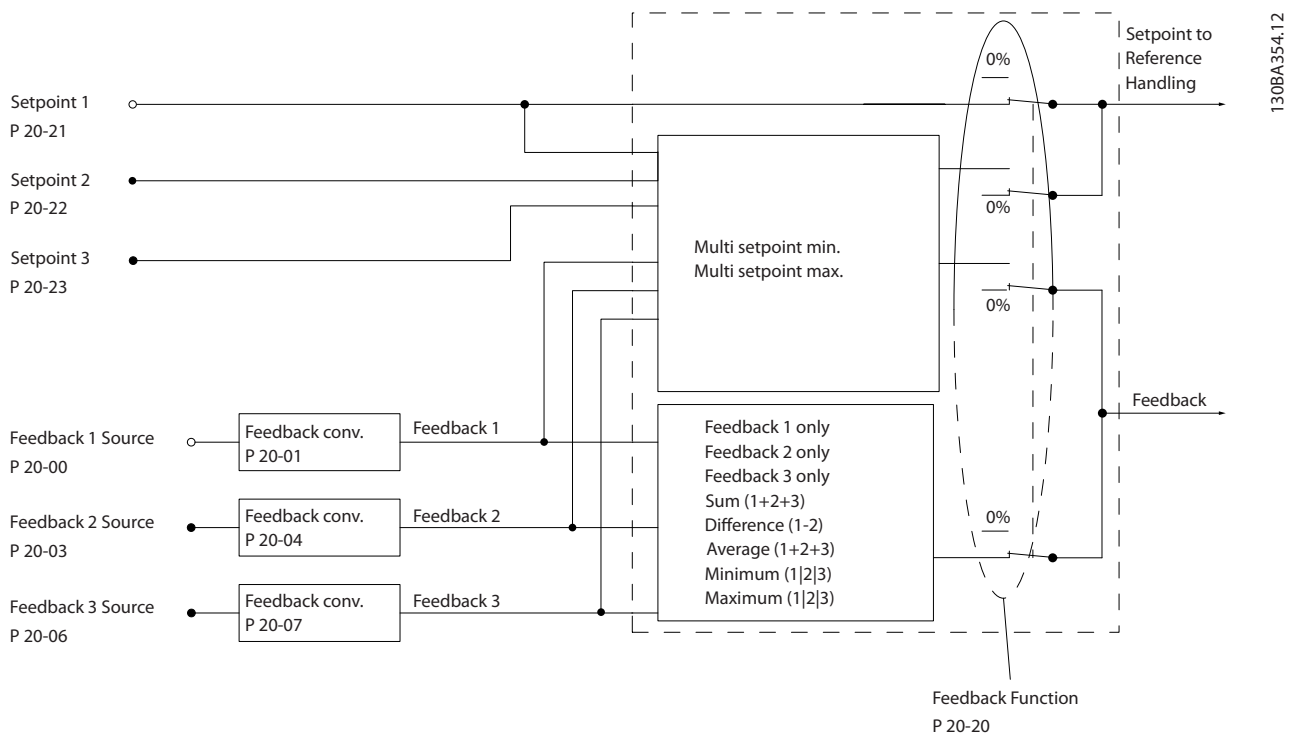

Illustration 3.46 Feedback

20-00 Feedback 1 Source	
Option:	Function:
	<p>NOTICE</p> <p>If feedback is not used, set its source to [0] No Function. Parameter 20-20 Feedback Function determines how the PID controller uses the 3 possible feedbacks.</p> <p>Up to 3 different feedback signals can be used to provide the feedback signal for the frequency converter's PID controller. This parameter defines which input is used as the source of the first feedback signal.</p>

20-00 Feedback 1 Source	
Option:	Function:
	Analog input X30/11 and analog input X30/12 refer to inputs on VLT® General Purpose I/O MCB 101.
[0]	No function
[1]	Analog Input 53
[2] *	Analog Input 54
[3]	Pulse input 29
[4]	Pulse input 33
[7]	Analog Input X30/11
[8]	Analog Input X30/12
[9]	Analog Input X42/1

20-00 Feedback 1 Source		
Option:	Function:	
[10]	Analog Input X42/3	
[11]	Analog Input X42/5	
[100]	Bus Feedback 1	
[101]	Bus Feedback 2	
[102]	Bus feedback 3	
[110]	Air Pres. to Flow	

20-01 Feedback 1 Conversion		
Option:	Function:	
		This parameter allows a conversion function to be applied to feedback 1.
[0]	Linear	No effect on the feedback.
[1]	Square root	Commonly used when a pressure sensor is used to provide flow feedback (($flow \propto \sqrt{pressure}$)).
[2]	Pressure to temperature *	Used in compressor applications to provide temperature feedback using a pressure sensor. The temperature of the refrigerant is calculated using the following formula: $Temperature = \frac{A2}{(\ln(Pe + 1) - A1) - A3},$ where A1, A2 and A3 are refrigerant-specific constants. Select the refrigerant in <i>parameter 20-30 Refrigerant</i> . <i>Parameter 20-21 Setpoint 1</i> through <i>parameter 20-23 Setpoint 3</i> allow the values of A1, A2, and A3 to be entered for a refrigerant that is not listed in <i>parameter 20-30 Refrigerant</i> .

20-02 Feedback 1 Source Unit		
Option:	Function:	
		NOTICE This parameter is only available when using pressure to temperature feedback conversion. If option [0] Linear is selected in <i>parameter 20-01 Feedback 1 Conversion</i> , the setting of any option in <i>parameter 20-02 Feedback 1 Source Unit</i> does not matter as a conversion is 1-to-1. This parameter determines the unit that is used for this feedback source, before applying the feedback conversion of <i>parameter 20-01 Feedback 1 Conversion</i> . This unit is not used by the PID controller.
[0]		
[1]	%	
[5]	PPM	
[10]	1/min	

20-02 Feedback 1 Source Unit		
Option:	Function:	
[11]	RPM	
[12]	Pulse/s	
[20]	l/s	
[21]	l/min	
[22]	l/h	
[23]	m ³ /s	
[24]	m ³ /min	
[25]	m ³ /h	
[30]	kg/s	
[31]	kg/min	
[32]	kg/h	
[33]	t/min	
[34]	t/h	
[40]	m/s	
[41]	m/min	
[45]	m	
[60]	°C	
[70]	mbar	
[71]	bar	
[72]	Pa	
[73]	kPa	
[74]	m WG	
[80]	kW	
[120]	GPM	
[121]	gal/s	
[122]	gal/min	
[123]	gal/h	
[124]	CFM	
[125]	ft ³ /s	
[126]	ft ³ /min	
[127]	ft ³ /h	
[130]	lb/s	
[131]	lb/min	
[132]	lb/h	
[140]	ft/s	
[141]	ft/min	
[145]	ft	
[160]	°F	
[170]	psi	
[171]	lb/in ²	
[172]	in WG	
[173]	ft WG	
[180]	HP	

20-03 Feedback 2 Source		
Option:	Function:	
		See <i>parameter 20-00 Feedback 1 Source</i> for details.
[0] *	No function	
[1]	Analog Input 53	
[2]	Analog Input 54	
[3]	Pulse input 29	

20-03 Feedback 2 Source		
Option:	Function:	
[4]	Pulse input 33	
[7]	Analog Input X30/11	
[8]	Analog Input X30/12	
[9]	Analog Input X42/1	
[10]	Analog Input X42/3	
[11]	Analog Input X42/5	
[100]	Bus Feedback 1	
[101]	Bus Feedback 2	
[102]	Bus feedback 3	
[110]	Air Pres. to Flow	

20-04 Feedback 2 Conversion		
Option:	Function:	
		See parameter 20-01 Feedback 1 Conversion for details.
[0] *	Linear	
[1]	Square root	
[2]	Pressure to temperature	

20-05 Feedback 2 Source Unit		
Option:	Function:	
		See parameter 20-02 Feedback 1 Source Unit for details.

20-06 Feedback 3 Source		
Option:	Function:	
		See parameter 20-00 Feedback 1 Source for details.
[0] *	No function	
[1]	Analog Input 53	
[2]	Analog Input 54	
[3]	Pulse input 29	
[4]	Pulse input 33	
[7]	Analog Input X30/11	
[8]	Analog Input X30/12	
[9]	Analog Input X42/1	
[10]	Analog Input X42/3	
[11]	Analog Input X42/5	
[100]	Bus Feedback 1	
[101]	Bus Feedback 2	
[102]	Bus feedback 3	
[110]	Air Pres. to Flow	

20-07 Feedback 3 Conversion		
Option:	Function:	
		See parameter 20-01 Feedback 1 Conversion for details.
[0] *	Linear	
[1]	Square root	
[2]	Pressure to temperature	

20-08 Feedback 3 Source Unit		
Option:	Function:	
		See parameter 20-02 Feedback 1 Source Unit for details.

20-12 Reference/Feedback Unit		
Option:	Function:	
		See parameter 20-02 Feedback 1 Source Unit for details.
[60] *	°C	
[160]	°F	

3.16.2 20-2* Feedback/Setpoint

This parameter group is used to determine how the PID controller uses the 3 possible feedback signals to control the output frequency of the frequency converter. This group is also used to store the 3 internal setpoint references.

20-20 Feedback Function		
Option:	Function:	
		This parameter determines how the 3 possible feedbacks are used to control the output frequency of the frequency converter.
[0]	Sum	<p>Sets up the PID controller to use the sum of feedback 1, feedback 2, and feedback 3 as the feedback.</p> <p>NOTICE Set any unused feedbacks to [0] No Function in</p> <ul style="list-style-type: none"> Parameter 20-00 Feedback 1 Source. Parameter 20-03 Feedback 2 Source. Parameter 20-06 Feedback 3 Source. <p>The sum of setpoint 1 and any other references that are enabled (see parameter group 3-1* References) are used as the PID controller's setpoint reference.</p>
[1]	Difference	<p>Sets up the PID controller to use the difference between feedback 1 and feedback 2 as the feedback. Feedback 3 is not used with this selection. Only setpoint 1 is used. The sum of setpoint 1 and any other references that are enabled (see parameter group 3-1* References) are used as the PID controller's setpoint reference.</p>
[2]	Average	<p>Sets up the PID controller to use the average of feedback 1, feedback 2, and feedback 3 as the feedback.</p>

20-20 Feedback Function		
Option:	Function:	
		<p>NOTICE Set any unused feedbacks to [0] No Function in</p> <ul style="list-style-type: none"> Parameter 20-00 Feedback 1 Source. Parameter 20-03 Feedback 2 Source. Parameter 20-06 Feedback 3 Source. <p>The sum of setpoint 1 and any other references that are enabled (see <i>parameter group 3-1* References</i>) are used as the PID controller's setpoint reference.</p>
[3] *	Minimum	<p>Sets up the PID controller to compare feedback 1, feedback 2, and feedback 3. The PID controller uses the lowest value as the feedback.</p> <p>NOTICE Set any unused feedbacks to [0] No Function in</p> <ul style="list-style-type: none"> Parameter 20-00 Feedback 1 Source. Parameter 20-03 Feedback 2 Source. Parameter 20-06 Feedback 3 Source. <p>Only setpoint 1 is used. The sum of setpoint 1 and any other references that are enabled (see <i>parameter group 3-1* References</i>) are used as the PID controller's setpoint reference.</p>
[4]	Maximum	<p>Sets up the PID controller to compare feedback 1, feedback 2, and feedback 3 and use the highest value as the feedback.</p> <p>NOTICE Set any unused feedbacks to [0] No Function in</p> <ul style="list-style-type: none"> Parameter 20-00 Feedback 1 Source. Parameter 20-03 Feedback 2 Source. Parameter 20-06 Feedback 3 Source. <p>Only setpoint 1 is used. The sum of setpoint 1 and any other references that are enabled (see</p>

20-20 Feedback Function		
Option:	Function:	
		<p><i>parameter group 3-1* References</i>) are used as the PID controller's setpoint reference.</p>
[5]	Multi Setpoint Min	<p>Sets up the PID controller to calculate the difference between feedback 1 and setpoint 1, feedback 2 and setpoint 2, and feedback 3 and setpoint 3. It uses the feedback/setpoint pair in which the feedback is the farthest below its corresponding setpoint reference. If all feedback signals are above their corresponding setpoints, the PID controller uses the feedback/setpoint pair with the least difference between the 2.</p> <p>NOTICE If only 2 feedback signals are used, set the non-used feedback to [0] No Function in</p> <ul style="list-style-type: none"> Parameter 20-00 Feedback 1 Source. Parameter 20-03 Feedback 2 Source. Parameter 20-06 Feedback 3 Source. <p>Note that each setpoint reference is the sum of its respective parameter value (<i>parameter 20-21 Setpoint 1, parameter 20-22 Setpoint 2, and parameter 20-23 Setpoint 3</i>) and any other references that are enabled (see <i>parameter group 3-1* References</i>).</p>
[6]	Multi Setpoint Max	<p>Sets up the PID controller to calculate the difference between feedback 1 and setpoint 1, feedback 2 and setpoint 2, and feedback 3 and setpoint 3. It uses the feedback/setpoint pair in which the feedback is farthest above its corresponding setpoint reference. If all feedback signals are below their corresponding setpoints, the PID controller uses the feedback/setpoint pair with the least difference between the 2.</p>

20-20 Feedback Function	
Option:	Function:
	<p>NOTICE</p> <p>If only 2 feedback signals are used, set the non-used feedback to [0] No Function in</p> <ul style="list-style-type: none"> Parameter 20-00 Feedback 1 Source. Parameter 20-03 Feedback 2 Source. Parameter 20-06 Feedback 3 Source. <p>Note that each setpoint reference is the sum of its respective parameter value (parameter 20-21 Setpoint 1, parameter 20-22 Setpoint 2, and parameter 20-23 Setpoint 3) and any other references that are enabled (see parameter group 3-1* References).</p>

NOTICE

Set any unused feedback to [0] No function in

- Parameter 20-00 Feedback 1 Source.
- Parameter 20-03 Feedback 2 Source.
- Parameter 20-06 Feedback 3 Source.

- Be shown on the frequency converter's display.
- Be used to control a frequency converter's analog output.
- Be transmitted over various serial communication protocols.

The frequency converter can be configured to handle multi-zone applications. 2 different multi-zone applications are supported

- Multi-zone, single setpoint
- Multi-zone, multi-setpoint

Examples 1 and 2 illustrate the difference between the 2 applications:

Example 1 – Multi-zone, single setpoint

A VAV (variable air volume) VLT® HVAC Drive system must ensure a minimum pressure at selected VAV boxes. Due to the varying pressure losses in each duct, the pressure at each VAV box cannot be assumed to be the same. The minimum pressure required is the same for all VAV boxes. This control method can be set up by setting parameter 20-20 Feedback Function to [3] Minimum, and entering the desired pressure in parameter 20-21 Setpoint 1. If any feedback is below the setpoint, the PID controller increases the fan speed. If all feedbacks are above the setpoint, the PID controller decreases the compressor speed.

The PID controller uses the feedback resulting from the function selected in parameter 20-20 Feedback Function to control the output frequency of the frequency converter. This feedback can also:

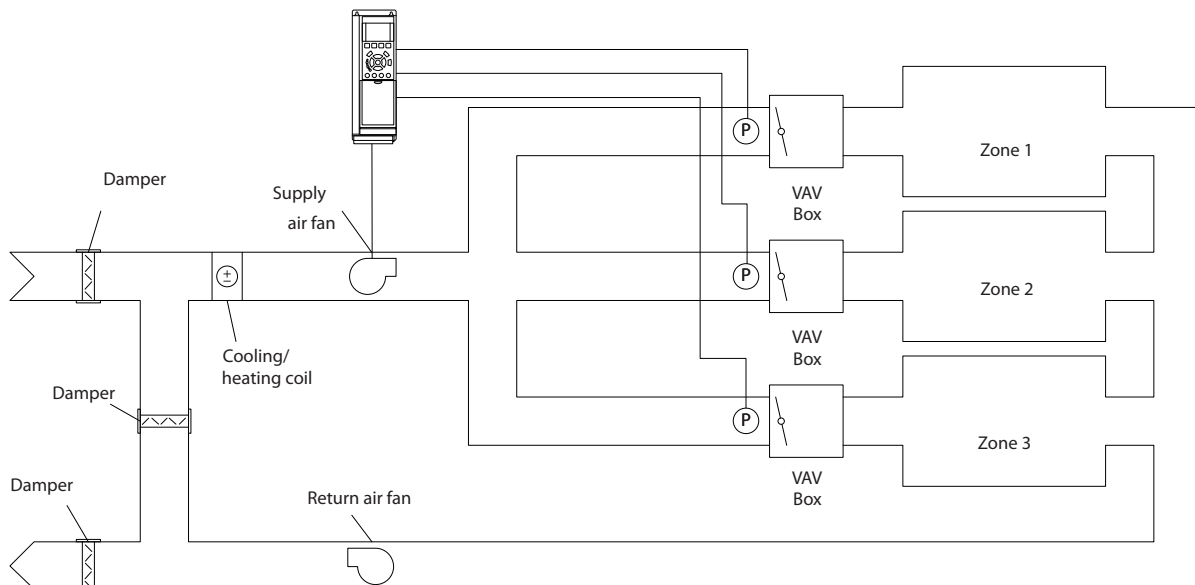

Illustration 3.47 Example, Multi-zone, Single Setpoint

130BA353.10

Example 2 – Multi-zone, multi-setpoint

The previous example illustrates the use of multi-zone, single-setpoint control. If the zones require different pressures for each VAV box, each setpoint may be specified in

- *Parameter 20-21 Setpoint 1.*
- *Parameter 20-22 Setpoint 2.*
- *Parameter 20-23 Setpoint 3.*

By selecting [5] *Multi-setpoint minimum* in *parameter 20-20 Feedback Function*, the PID controller increases the compressor speed if any one of the feedbacks is below its setpoint. If all feedbacks are above their individual setpoints, the PID controller decreases the compressor speed.

20-21 Setpoint 1		
Range:	Function:	
0 ProcessCtrlUnit*	[-999999.999 - 999999.999 ProcessCtrlUnit]	Setpoint 1 is used in closed-loop mode to enter a setpoint reference that is used by the frequency converter's PID controller. See the description of <i>parameter 20-20 Feedback Function</i> . NOTICE The setpoint reference entered here is added to any other references that are enabled (see <i>parameter group 3-1* References</i>).

20-22 Setpoint 2		
Range:	Function:	
0 ProcessCtrlUnit*	[-999999.999 - 999999.999 ProcessCtrlUnit]	Setpoint 2 is used in closed-loop mode to enter a setpoint reference for the PID controller. See the description of <i>parameter 20-20 Feedback Function</i> . NOTICE The setpoint reference entered here is added to any other references that are enabled (see <i>parameter group 3-1* References</i>).

20-23 Setpoint 3		
Range:	Function:	
0 ProcessCtrlUnit*	[-999999.999 - 999999.999 ProcessCtrlUnit]	Setpoint 3 is used in closed-loop mode to enter a setpoint reference that may be used by the frequency converter's PID controller. See the description of <i>parameter 20-20 Feedback Function</i> . NOTICE The setpoint reference entered here is added to any other references that are enabled (see <i>parameter group 3-1* References</i>).

20-25 Setpoint Type		
Select the setpoint type.		
Option:	Function:	
[0]	Fixed	
[1]	Fixed with Night Setback	
[2]	Floating	
[3]	Fixed with Night Speed	

3.16.3 20-3* Feedback Adv. Conversion

In air conditioning compressor applications it is often useful to control the system based on the temperature of the refrigerant. However, it is generally more convenient to directly measure its pressure. This parameter group allows the frequency converter's PID controller to convert refrigerant pressure measurements into temperature values.

20-30 Refrigerant		
Option:	Function:	
		Select the refrigerant used in the compressor application. This parameter must be specified correctly for the pressure to temperature conversion to be accurate. If the refrigerant used is not listed in options [0]–[6], select [7] <i>User defined</i> . Then, use <i>parameter 20-31 User Defined Refrigerant A1</i> , <i>parameter 20-32 User Defined Refrigerant A2</i> , and <i>parameter 20-33 User Defined Refrigerant A3</i> to provide A1, A2, and A3 for the equation below: $\text{Temperature} = \frac{A2}{(\ln(Pe + 1) - A1) - A3}$
[0]	User defined	
[1]	R12	
[2]	R22	
[3]	R134a	

20-30 Refrigerant		
Option:	Function:	
[4]	R502	
[5]	R717	
[6]	R13	
[7]	R13b1	
[8]	R23	
[9]	R500	
[10]	R503	
[11]	R114	
[12]	R142b	
[14]	R32	
[15]	R227	
[16]	R401A	
[17]	R507	
[18]	R402A	
[19] *	R404A	
[20]	R407C	
[21]	R407A	
[22]	R407B	
[23]	R410A	
[24]	R170	
[25]	R290	
[26]	R600	
[27]	R600a	
[28]	R744	
[29]	R1270	
[30]	R417A	
[31]	R422A	
[32]	R413A	
[33]	Isceon 29	
[34]	R427A	
[35]	R438A	
[36]	Opteon XP10	
[37]	R407F	
[38]	R1234ze	
[39]	R1234yf	

20-31 User Defined Refrigerant A1		
Range:	Function:	
10*	[8 - 12]	Use this parameter to enter the value of coefficient A1 when <i>parameter 20-30 Refrigerant</i> is set to [7] <i>User defined</i> .

20-32 User Defined Refrigerant A2		
Range:	Function:	
-2250*	[-3000 - -1500]	Use this parameter to enter the value of coefficient A2 when <i>parameter 20-30 Refrigerant</i> is set to [7] <i>User defined</i> .

20-33 User Defined Refrigerant A3		
Range:	Function:	
250*	[200 - 300]	Use this parameter to enter the value of coefficient A3 when <i>parameter 20-30 Refrigerant</i> is set to [7] <i>User defined</i> .

20-40 Thermostat/Pressostat Function		
Select the thermostat/pressostat function. Only available in a closed-loop process.		
Option:	Function:	
[0]	Disabled	
[1]	Absolute	
[2]	Relative	

20-41 Cut-out Value		
Enter the cutout value at which the compressor stops.		
Range:	Function:	
Size related*	[-999999.999 - 999999.999 Reference-FeedbackUnit]	

20-42 Cut-in Value		
Enter cut-in value at which the compressor starts.		
Range:	Function:	
Size related*	[-999999.999 - 999999.999 Reference-FeedbackUnit]	

3.16.4 20-7* PID Auto-tuning

The frequency converter PID closed-loop controller (*parameter group 20-** FC Closed Loop*) can be auto-tuned, simplifying and saving time during commissioning, while ensuring accurate PID control adjustment. To use auto-tuning, configure the frequency converter for closed loop in *parameter 1-00 Configuration Mode*.

Use a graphical local control panel (GLCP) to react to messages during the auto-tuning sequence.

Enabling *parameter 20-79 PID Autotuning* puts the frequency converter into auto-tuning mode. The LCP then shows on-screen instructions.

To start the fan/pump, press [Auto On] and apply a start signal. Adjust the speed manually by pressing [▲] or [▼] to a level where the feedback is around the system setpoint.

NOTICE

It is not possible to run the motor at maximum or minimum speed when manually adjusting the motor speed due to the need of giving the motor a step in the speed during auto-tuning.

PID auto-tuning introduces step changes while operating at a steady state and then monitors the feedback. From the feedback response, the required values for *parameter 20-93 PID Proportional Gain* and *parameter 20-94 PID Integral Time* are calculated. *Parameter 20-95 PID Differentiation Time* is set to value 0 (zero). *Parameter 20-81 PID Normal/ Inverse Control* is determined during the tuning process.

These calculated values are presented in the LCP and can be either accepted or rejected. Once accepted, the values are written to the relevant parameters and auto-tuning mode is disabled in *parameter 20-79 PID Autotuning*. Depending on the system, the time required to carry out auto-tuning could be several minutes.

Before carrying out the PID auto-tuning, set the following parameters according to the load inertia:

- *Parameter 3-41 Ramp 1 Ramp Up Time.*
- *Parameter 3-42 Ramp 1 Ramp Down Time.*

or

- *Parameter 3-51 Ramp 2 Ramp Up Time.*
- *Parameter 3-52 Ramp 2 Ramp Down Time.*

If PID auto-tuning is carried out with slow ramp times, the auto-tuned parameters typically result in very slow control. Before activating PID auto-tuning, remove excessive feedback sensor noise using the input filter (*parameter groups 6-** Analog In/Out, 5-5* Pulse Input* and *26-** Analog I/O Option MCB 109, parameter 6-16 Terminal 53 Filter Time Constant, parameter 6-26 Terminal 54 Filter Time Constant, parameter 5-54 Pulse Filter Time Constant #29, parameter 5-59 Pulse Filter Time Constant #33*) before activating PID auto-tuning. To obtain the most accurate controller parameters, carry out PID auto-tuning when the application runs in typical operation, that is with a typical load.

20-70 Closed Loop Type	
Option:	Function:
[0] *	Auto
	Select the application response speed if it is known. The default setting is sufficient for most applications. A more precise value decreases the time needed for carrying out PID adaptation. The setting has no impact on values of parameters and only affects the auto-tuning speed.
	Takes 30–60 s to complete.

20-70 Closed Loop Type	
Option:	Function:
[1]	Fast Pressure
[2]	Slow Pressure
[3]	Fast Temperature
[4]	Slow Temperature

20-71 PID Performance	
Option:	Function:
[0] *	Normal
[1]	Fast

20-72 PID Output Change	
Range:	Function:
0.10* [0.01 - 0.50]	This parameter sets the magnitude of step change during auto-tuning. The value is a percentage of full speed. That is, if maximum output frequency in <i>parameter 4-13 Motor Speed High Limit [RPM]/parameter 4-14 Motor Speed High Limit [Hz]</i> is set to 50 Hz, 0.10 is 10% of 50 Hz, which is 5 Hz. Set this parameter to a value resulting in feedback changes of 10–20% for best tuning accuracy.

20-73 Minimum Feedback Level	
Range:	Function:
-999999 ProcessCtrlUnit*	[-999999.999 - par. 20-74 ProcessCtrlUnit]

20-74 Maximum Feedback Level	
Range:	Function:
999999 ProcessCtrlUnit*	[par. 20-73 - 999999.999 ProcessCtrlUnit]

20-79 PID Autotuning		
Option:	Function:	
		This parameter starts the PID auto-tuning sequence. Once the auto-tuning has successfully completed and the settings have been accepted or rejected by pressing [OK] or [Cancel] at the end of tuning, this parameter is reset to [0] <i>Disabled</i> .
[0] *	Disabled	
[1]	Enabled	

3.16.5 20-8* PID Basic Settings

This parameter group is used to configure the basic operation of the PID controller, including how it responds to feedback that is above or below the setpoint, the speed at which it first starts functioning, and when it indicates that the system has reached the setpoint.

20-81 PID Normal/ Inverse Control		
Option:	Function:	
[0]	Normal	The frequency converter's output frequency decreases when the feedback is greater than the setpoint reference. This behaviour is common for pressure-controlled supply fan and pump applications.
[1] *	Inverse	The frequency converter's output frequency increases when the feedback is greater than the setpoint reference. This behaviour is common for temperature-controlled cooling applications, such as cooling towers.

20-82 PID Start Speed [RPM]		
Range:	Function:	
Size related* [0 - par. 4-13 RPM]		<p>NOTICE</p> <p>This parameter is only visible if <i>parameter 0-02 Motor Speed Unit is set to [0] RPM</i>.</p> <p>When the frequency converter is first started, it initially ramps up to this output speed in open-loop mode, following the active ramp-up time. When the output speed programmed is reached, the frequency converter automatically switches to closed-loop mode, and the PID controller begins to function. This is useful in applications that require quick acceleration to a minimum speed at start-up.</p>

20-83 PID Start Speed [Hz]		
Range:	Function:	
Size related* [0 - par. 4-14 Hz]		<p>NOTICE</p> <p>This parameter is only visible if <i>parameter 0-02 Motor Speed Unit is set to [1] Hz</i>.</p> <p>When the frequency converter is first started, it initially ramps up to this output frequency in open-loop mode, following the active ramp-up time. When the output frequency programmed is reached, the frequency converter automatically switches to closed-loop mode and the PID controller begins to function. This is useful in applications that require quick acceleration to a minimum speed at start-up.</p>

20-84 On Reference Bandwidth		
Range:	Function:	
5 %* [0 - 200 %]		<p>When the difference between the feedback and the setpoint reference is less than the value of this parameter, the frequency converter's display shows <i>Run on Reference</i>. This status can be communicated externally by programming the function of a digital output for [8] <i>Run on Reference/No Warning</i>. Also, for serial communications, the <i>On Reference</i> status bit of the frequency converter status word is high (value = 1).</p> <p>The <i>On Reference Bandwidth</i> is calculated as a percentage of the setpoint reference.</p>

3.16.6 20-9* PID Controller

This group provides the ability to manually adjust this PID controller. By adjusting the PID controller parameters, the control performance may be improved. See *VLT® Refrigeration Drive FC 103 Design Guide* for guidelines on adjusting the PID controller parameters.

20-91 PID Anti Windup		
Option:		Function:
		NOTICE Option [1] On is activated automatically, if 1 of the following options is selected in parameters in parameter group 21-** Ext. Closed Loop: [0] Normal, [X] Enabled Ext CLX PID.
[0]	Off	The integrator continues to change value also after output has reached 1 of the extremes. This can afterwards cause a delay of change of the output of the controller.
[1] *	On	The integrator is locked if the output of the built-in PID controller has reached 1 of the extremes (minimum or maximum value) and therefore is not able to add further changes to the value of the process parameter controlled. This allows the controller to respond more quickly when it can control the system again.

20-93 PID Proportional Gain		
Range:		Function:
0.50*	[0 - 10]	The proportional gain indicates the number of times the error between the setpoint and the feedback signal is to be applied.

20-94 PID Integral Time		
Range:		Function:
30 s*	[0.01 - 10000 s]	The integrator accumulates a contribution to the output from the PID controller as long as there is a deviation between the reference/ setpoint and feedback signals. The contribution is proportional to the size of the deviation. This ensures that the deviation (error) approaches zero. Quick response on any deviation is obtained when the integral time is set to a low value. Setting it too low, however, may cause the control to become unstable. The value set is the time needed for the integrator to add the same contribution as the proportional for a certain deviation. If the value is set to 10000, the controller acts as a pure proportional controller with a P-band based on the value set in parameter 20-93 PID Proportional Gain. When no deviation is present, the output from the proportional controller is 0.

20-95 PID Differentiation Time		
Range:		Function:
0 s*	[0 - 10 s]	The differentiator monitors the rate of change of the feedback. If the feedback is changing quickly, it adjusts the output of the PID controller to reduce the rate of change of the feedback. Quick PID controller response is obtained when this

20-95 PID Differentiation Time		
Range:		Function:
		value is large. However, if too large of a value is used, the frequency converter's output frequency may become unstable. Differentiation time is useful in situations where fast frequency converter response and precise speed control are required. It can be difficult to adjust this for proper system control. Differentiation time is not commonly used in refrigeration applications. Therefore, it is best to leave this parameter at 0 or OFF.

20-96 PID Diff. Gain Limit		
Range:		Function:
5*	[1 - 50]	The differential function of a PID controller responds to the rate of change of the feedback. As a result, an abrupt change in the feedback can cause the differential function to make a very large change in the PID controller output. This parameter limits the maximum effect that the PID controller differential function can produce. A smaller value reduces the maximum effect of the PID controller differential function. This parameter is only active when parameter 20-95 PID Differentiation Time is not set to OFF (0 s).

3.17 Parameters: 21-** Extended Closed Loop

3.17.1 21-** Ext. Closed Loop

The VLT® Refrigeration Drive FC 103 offers 3 extended closed-loop PID controllers in addition to the PID controller. These can be configured independently to control either external actuators (valves, dampers, and so on.) or be used with the internal PID controller to improve the dynamic responses to setpoint changes or load disturbances.

The extended closed-loop PID controllers may be interconnected or connected to the PID closed-loop controller to form a dual-loop configuration.

To control a modulating device (for example a valve motor), this device must be a positioning servo motor with built-in electronics accepting either a 0–10 V (signal from VLT® Analog I/O Option MCB 109) or a 0/4–20 mA (signal from control card and/or VLT® General Purpose I/O MCB 101) control signal.

The output function can be programmed in the following parameters:

- Control card, terminal 42: *Parameter 6-50 Terminal 42 Output* (setting [113]...[115] or [149]...[151], Ext. Closed Loop 1/2/3)
- VLT® General Purpose I/O MCB 101, terminal X30/8: *Parameter 6-60 Terminal X30/8 Output*, (setting [113]...[115] or [149]...[151], Ext. Closed Loop 1/2/3)
- VLT® Analog I/O Option MCB 109, terminal X42/7...11: *Parameter 26-40 Terminal X42/7 Output*, *parameter 26-50 Terminal X42/9 Output*, *parameter 26-60 Terminal X42/11 Output* (setting [113]...[115], Ext. Closed Loop 1/2/3)

VLT® General Purpose I/O MCB 101 and VLT® Analog I/O Option MCB 109 are optional cards.

3.17.2 21-0* Extended CL Autotuning

The extended closed-loop PID controllers can each be auto tuned, simplifying and saving time during commissioning, while ensuring accurate PID control adjustment.

To use PID auto tuning, configure the relevant extended PID controller for the application.

Use a graphical LCP to react on messages during the auto tuning sequence.

Enabling auto tuning, *parameter 21-09 PID Autotuning* puts the relevant PID controller into PID auto tuning mode. The LCP then provides on-screen instructions.

PID auto tuning introduces step changes and then monitors the feedback. Based on the feedback response, the following required values are calculated:

- PID proportional gain.
 - *Parameter 21-21 Ext. 1 Proportional Gain* for EXT CL 1.
 - *Parameter 21-41 Ext. 2 Proportional Gain* for EXT CL 2.
 - *Parameter 21-61 Ext. 3 Proportional Gain* for EXT CL 3.
- Integral time.
 - *Parameter 21-22 Ext. 1 Integral Time* for EXT CL 1.
 - *Parameter 21-42 Ext. 2 Integral Time* for EXT CL 2.
 - *Parameter 21-62 Ext. 3 Integral Time* for EXT CL 3 are calculated.

The PID differentiation time is set to 0 in the following parameters:

- *Parameter 21-23 Ext. 1 Differentiation Time* for EXT CL 1.
- *Parameter 21-43 Ext. 2 Differentiation Time* for EXT CL 2.
- *Parameter 21-63 Ext. 3 Differentiation Time* for EXT CL 3 are set to value 0 (zero).
- *Parameter 21-20 Ext. 1 Normal/Inverse Control* for EXT CL 1.
- *Parameter 21-40 Ext. 2 Normal/Inverse Control* for EXT CL 2.
- *Parameter 21-60 Ext. 3 Normal/Inverse Control* for EXT CL 3 are determined during the tuning process.

These calculated values are presented on the LCP and can either be accepted or rejected. Once accepted, the values are written to the relevant parameters, and PID auto tuning mode is disabled in *parameter 21-09 PID Autotuning*. Depending on the system being controlled, the time required to carry out PID auto tuning could be several minutes.

Before activating the PID auto tuning, remove excessive feedback sensor noise using the input filter (parameter groups 5-5* *Pulse Input*, 6-** *Analog In/Out* and 26-** *Analog I/O Option MCB 109*, terminal 53/54 filter time constant, and pulse filter time constant #29/33) before activating PID auto tuning.

21-00 Closed Loop Type		
Option:	Function:	
		This parameter defines the application response. The default mode should be sufficient for most applications. If the relative application speed is known, it can be selected here. This decreases the time needed for carrying out PID auto tuning. The setting has no impact on the value of the tuned parameters and is used only for the PID auto tuning sequence.
[0] *	Auto	
[1]	Fast Pressure	
[2]	Slow Pressure	
[3]	Fast Temperature	
[4]	Slow Temperature	

21-01 PID Performance		
Option:	Function:	
[0] *	Normal	Normal setting of this parameter is suitable for pressure control in fan systems.
[1]	Fast	Fast setting would generally be used in pumping systems, where a faster control response is desirable.

21-02 PID Output Change		
Range:	Function:	
0.10*	[0.01 - 0.50]	This parameter sets the magnitude of step change during auto tuning. The value is a percentage of full operating range. That is, if the maximum analog output voltage is set to 10 V, 0.10 is 10% of 10 V, which is 1 V. Set this parameter to a value resulting in feedback changes of 10–20% for best tuning accuracy.

21-03 Minimum Feedback Level		
Range:	Function:	
-999999*	[-999999.999 - par. 21-04]	Enter the minimum allowable feedback level in user units as defined in: <ul style="list-style-type: none"> Parameter 21-10 Ext. 1 Ref./ Feedback Unit for EXT CL 1. Parameter 21-30 Ext. 2 Ref./ Feedback Unit for EXT CL 2. Parameter 20-05 Feedback 2 Source Unit for EXT CL 3. <p>If the level drops below parameter 21-03 Minimum Feedback Level, PID auto tuning is aborted, and an error message appears in the display.</p>

21-04 Maximum Feedback Level		
Range:	Function:	
999999*	[par. 21-03 - 999999.999]	Enter the maximum allowable feedback level in user units as defined in: <ul style="list-style-type: none"> Parameter 21-10 Ext. 1 Ref./ Feedback Unit for EXT CL 1. Parameter 21-30 Ext. 2 Ref./ Feedback Unit for EXT CL 2. Parameter 20-05 Feedback 2 Source Unit for EXT CL 3. <p>If the level rises above parameter 21-04 Maximum Feedback Level, PID auto tuning is aborted, and an error message appears in the display.</p>

21-09 PID Autotuning		
Option:	Function:	
		This parameter enables selection of the extended PID controller to be auto-tuned and starts the PID auto tuning for that controller. Once the auto tuning has successfully completed and the settings have been accepted or rejected by pressing [OK] or [Cancel] at the end of tuning, this parameter is reset to [0] Disabled.
[0] *	Disabled	
[1]	Enabled Ext CL1 PID	
[2]	Enabled Ext CL 2 PID	
[3]	Enabled Ext CL 3 PID	

3.17.3 21-1* Closed Loop 1 Ref/Feedback

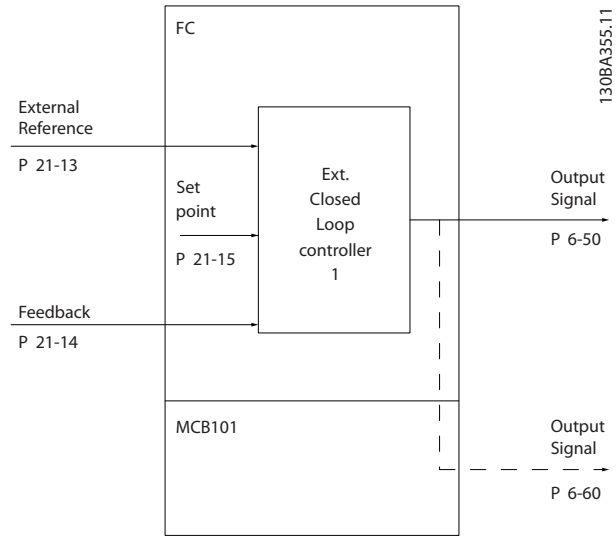

Illustration 3.48 Closed Loop 1 Ref/Feedback

21-10 Ext. 1 Ref./Feedback Unit		
Option:	Function:	
	Select the unit for the reference and feedback.	
[0]		
[1] *	%	
[5]	PPM	
[10]	1/min	
[11]	RPM	
[12]	Pulse/s	
[20]	l/s	
[21]	l/min	
[22]	l/h	
[23]	m ³ /s	
[24]	m ³ /min	
[25]	m ³ /h	
[30]	kg/s	
[31]	kg/min	
[32]	kg/h	
[33]	t/min	
[34]	t/h	
[40]	m/s	
[41]	m/min	
[45]	m	
[60]	°C	
[70]	mbar	
[71]	bar	
[72]	Pa	
[73]	kPa	
[74]	m WG	
[80]	kW	
[120]	GPM	
[121]	gal/s	
[122]	gal/min	

21-10 Ext. 1 Ref./Feedback Unit		
Option:	Function:	
[123]	gal/h	
[124]	CFM	
[125]	ft ³ /s	
[126]	ft ³ /min	
[127]	ft ³ /h	
[130]	lb/s	
[131]	lb/min	
[132]	lb/h	
[140]	ft/s	
[141]	ft/min	
[145]	ft	
[160]	°F	
[170]	psi	
[171]	lb/in ²	
[172]	in WG	
[173]	ft WG	
[180]	HP	

21-11 Ext. 1 Minimum Reference		
Range:	Function:	
0 ExtPID1Unit*	[-999999.999 - par. 21-12 ExtPID1Unit]	Select the minimum reference for the closed-loop 1 controller.

21-12 Ext. 1 Maximum Reference		
Range:	Function:	
100 ExtPID1Unit*	[par. 21-11 - 999999.999 ExtPID1Unit]	<p>NOTICE</p> <p>Set the value for <i>parameter 21-12 Ext. 1 Maximum Reference</i> before setting the values for the PID controller in <i>parameter group 20-9* PID Controller</i>.</p> <p>Select the maximum reference for the closed-loop 1 controller.</p> <p>The dynamics of the PID controller depend on the value set in this parameter. See also <i>parameter 21-21 Ext. 1 Proportional Gain</i>.</p>

21-13 Ext. 1 Reference Source		
Option:	Function:	
		This parameter defines which input on the frequency converter that should be treated as the source of the reference signal for the closed loop 1 controller. Analog input X30/11 and analog input X30/12 refer to inputs on the VLT® General Purpose I/O Card MCB 101.
[0] *	No function	
[1]	Analog Input 53	
[2]	Analog Input 54	
[7]	Pulse input 29	
[8]	Pulse input 33	
[20]	Digital pot.meter	
[21]	Analog input X30/11	
[22]	Analog input X30/12	
[23]	Analog Input X42/1	
[24]	Analog Input X42/3	
[25]	Analog Input X42/5	
[30]	Ext. Closed Loop 1	
[31]	Ext. Closed Loop 2	
[32]	Ext. Closed Loop 3	

21-14 Ext. 1 Feedback Source		
Option:	Function:	
		This parameter defines which input on the frequency converter should be treated as the source of the feedback signal for the closed-loop 1 controller. Analog input X30/11 and analog input X30/12 refer to inputs on the VLT® General Purpose I/O Card MCB 101.
[0] *	No function	
[1]	Analog Input 53	
[2]	Analog Input 54	
[3]	Pulse input 29	
[4]	Pulse input 33	
[7]	Analog Input X30/11	
[8]	Analog Input X30/12	
[9]	Analog Input X42/1	
[10]	Analog Input X42/3	
[11]	Analog Input X42/5	
[100]	Bus Feedback 1	
[101]	Bus Feedback 2	
[102]	Bus feedback 3	
[110]	Air Pres. to Flow	

21-15 Ext. 1 Setpoint		
Range:	Function:	
0 ExtPID1Unit*	[par. 21-11 - par. 21-12 ExtPID1Unit]	The setpoint reference is used in extended 1 closed loop. Ext.1

21-15 Ext. 1 Setpoint		
Range:	Function:	
		setpoint is added to the value from the Ext.1 Reference source selected in <i>parameter 21-13 Ext. 1 Reference Source</i> .

21-16 Ext. 1 PID Conversion		
Select the conversion method for integrated PID 1.		
Option:	Function:	
[0] *	Linear	
[1]	Square root	
[2]	Pressure to temperature	

21-17 Ext. 1 Reference [Unit]		
Range:	Function:	
0 ExtPID1Unit*	[-999999.999 - 999999.999 ExtPID1Unit]	Readout of the reference value for the closed-loop 1 controller.

21-18 Ext. 1 Feedback [Unit]		
Range:	Function:	
0 ExtPID1Unit*	[-999999.999 - 999999.999 ExtPID1Unit]	Readout of the feedback value for the closed-loop 1 controller.

21-19 Ext. 1 Output [%]		
Range:	Function:	
0 %*	[0 - 100 %]	Readout of the output value for the closed-loop 1 controller.

3.17.4 21-2* Closed Loop 1 PID

21-20 Ext. 1 Normal/Inverse Control		
Option:	Function:	
[0] *	Normal	Reduces the output when feedback is higher than the reference.
[1]	Inverse	Increase the output when feedback is higher than the reference.

21-21 Ext. 1 Proportional Gain		
Range:	Function:	
0.01* [0 - 10]		<p>NOTICE</p> <p>Always set <i>parameter 20-14 Maximum Reference/Feedb.</i> before setting the values for the PID controller in <i>parameter group 20-9* PID Controller</i>.</p> <p>The proportional gain indicates the number of times the error between the setpoint and the feedback signal is to be applied.</p>

If (error x gain) jumps with a value equal to what is set in *parameter 20-14 Maximum Reference/Feedb.*, the PID controller tries to change the output speed equal to what is set in *parameter 4-13 Motor Speed High Limit [RPM]/parameter 4-14 Motor Speed High Limit [Hz]*. However, the output speed is limited by this setting. The proportional band (error causing output to change from 0–100%) can be calculated with the formula

$$\left(\frac{1}{\text{Proportional Gain}}\right) \times (\text{Max Reference})$$

21-22 Ext. 1 Integral Time		
Range:		Function:
10000 s*	[0.01 - 10000 s]	Over time, the integrator accumulates a contribution to the output from the PID controller as long as there is a deviation between the reference/setpoint and feedback signals. The contribution is proportional to the size of the deviation. This ensures that the deviation (error) approaches 0. Quick response on any deviation is obtained when the integral time is set to a low value. Setting it too low, however, may cause the control to become unstable. The value set is the time needed for the integrator to add the same contribution as the proportional for a certain deviation. If the value is set to 10000, the controller acts as a pure proportional controller with a P-band based on the value set in <i>parameter 20-93 PID Proportional Gain</i> . When no deviation is present, the output from the proportional controller is 0.

21-23 Ext. 1 Differentiation Time		
Range:		Function:
0 s*	[0 - 10 s]	The differentiator does not react to a constant error. It only provides a gain when the feedback changes. The quicker the feedback changes, the stronger the gain from the differentiator.

21-24 Ext. 1 Dif. Gain Limit		
Range:		Function:
5*	[1 - 50]	Set a limit for the differentiator gain (DG). The DG increases if there are fast changes. Limit the DG to obtain a pure differentiator gain when changes are slow and a constant differentiator gain when quick changes occur.

3.17.5 21-3* Closed Loop 2 Ref/Fb

21-30 Ext. 2 Ref./Feedback Unit		
Option:	Function:	
	See <i>parameter 21-10 Ext. 1 Ref./Feedback Unit</i> for details.	
[0]		
[1] *	%	
[5]	PPM	
[10]	1/min	
[11]	RPM	
[12]	Pulse/s	
[20]	l/s	
[21]	l/min	
[22]	l/h	
[23]	m ³ /s	
[24]	m ³ /min	
[25]	m ³ /h	
[30]	kg/s	
[31]	kg/min	
[32]	kg/h	
[33]	t/min	
[34]	t/h	
[40]	m/s	
[41]	m/min	
[45]	m	
[60]	°C	
[70]	mbar	
[71]	bar	
[72]	Pa	
[73]	kPa	
[74]	m WG	
[80]	kW	
[120]	GPM	
[121]	gal/s	
[122]	gal/min	
[123]	gal/h	
[124]	CFM	
[125]	ft ³ /s	
[126]	ft ³ /min	
[127]	ft ³ /h	
[130]	lb/s	
[131]	lb/min	
[132]	lb/h	
[140]	ft/s	
[141]	ft/min	
[145]	ft	
[160]	°F	
[170]	psi	
[171]	lb/in ²	
[172]	in WG	
[173]	ft WG	
[180]	HP	

21-31 Ext. 2 Minimum Reference		
Range:	Function:	
0 ExtPID2Unit* [-999999.999 - par. 21-32 ExtPID2Unit]	See <i>parameter 21-11 Ext. 1 Minimum Reference</i> for details.	

21-32 Ext. 2 Maximum Reference		
Range:	Function:	
100 ExtPID2Unit* [par. 21-31 - 999999.999 ExtPID2Unit]	See <i>parameter 21-12 Ext. 1 Maximum Reference</i> for details.	

21-33 Ext. 2 Reference Source		
Option:	Function:	
	See <i>parameter 21-13 Ext. 1 Reference Source</i> for details.	
[0] *	No function	
[1]	Analog Input 53	
[2]	Analog Input 54	
[7]	Pulse input 29	
[8]	Pulse input 33	
[20]	Digital pot.meter	
[21]	Analog input X30/11	
[22]	Analog input X30/12	
[23]	Analog Input X42/1	
[24]	Analog Input X42/3	
[25]	Analog Input X42/5	
[30]	Ext. Closed Loop 1	
[31]	Ext. Closed Loop 2	
[32]	Ext. Closed Loop 3	

21-34 Ext. 2 Feedback Source		
Option:	Function:	
	See <i>parameter 21-14 Ext. 1 Feedback Source</i> for details.	
[0] *	No function	
[1]	Analog Input 53	
[2]	Analog Input 54	
[3]	Pulse input 29	
[4]	Pulse input 33	
[7]	Analog Input X30/11	
[8]	Analog Input X30/12	
[9]	Analog Input X42/1	
[10]	Analog Input X42/3	
[11]	Analog Input X42/5	
[100]	Bus Feedback 1	
[101]	Bus Feedback 2	
[102]	Bus feedback 3	
[110]	Air Pres. to Flow	

21-35 Ext. 2 Setpoint		
Range:	Function:	
0 ExtPID2Unit* [par. 21-31 - par. 21-32 ExtPID2Unit]	See <i>parameter 21-15 Ext. 1 Setpoint</i> for details.	

21-36 Ext. 2 PID Conversion		
Select the conversion method for integrated PID 2.		
Option:	Function:	
[0] *	Linear	
[1]	Square root	
[2]	Pressure to temperature	

21-37 Ext. 2 Reference [Unit]		
Range:	Function:	
0 ExtPID2Unit* [-999999.999 - 999999.999 ExtPID2Unit]	See <i>parameter 21-17 Ext. 1 Reference [Unit], Ext. 1 Reference [Unit]</i> , for details.	

21-38 Ext. 2 Feedback [Unit]		
Range:	Function:	
0 ExtPID2Unit* [-999999.999 - 999999.999 ExtPID2Unit]	See <i>parameter 21-18 Ext. 1 Feedback [Unit]</i> for details.	

21-39 Ext. 2 Output [%]		
Range:	Function:	
0 %* [0 - 100 %]	See <i>parameter 21-19 Ext. 1 Output [%]</i> for details.	

3.17.6 21-4* Closed Loop 2 PID

21-40 Ext. 2 Normal/Inverse Control		
Option:	Function:	
	See <i>parameter 21-20 Ext. 1 Normal/Inverse Control</i> for details.	
[0] *	Normal	
[1]	Inverse	

21-41 Ext. 2 Proportional Gain		
Range:	Function:	
0.01* [0 - 10]	See <i>parameter 21-21 Ext. 1 Proportional Gain</i> for details.	

21-42 Ext. 2 Integral Time		
Range:	Function:	
10000 s* [0.01 - 10000 s]	See <i>parameter 21-22 Ext. 1 Integral Time</i> for details.	

21-43 Ext. 2 Differentiation Time		
Range:	Function:	
0 s* [0 - 10 s]	See <i>parameter 21-23 Ext. 1 Differentiation Time</i> for details.	

21-44 Ext. 2 Dif. Gain Limit		
Range:	Function:	
5* [1 - 50]	See <i>parameter 21-24 Ext. 1 Dif. Gain Limit</i> for details.	

3.17.7 21-5* Closed Loop 3 Ref/Fb

20-05 Feedback 2 Source Unit

See parameter 20-02 Feedback 1 Source Unit for details.

Option: **Function:**

[0] *	Linear	
-------	--------	--

21-51 Ext. 3 Minimum Reference

Range: **Function:**

0 ExtPID3Unit*	[-999999.999 - par. 21-52 ExtPID3Unit]	See parameter 21-11 Ext. 1 Minimum Reference for details.
----------------	--	---

21-52 Ext. 3 Maximum Reference

Range: **Function:**

100 ExtPID3Unit*	[par. 21-51 - 999999.999 ExtPID3Unit]	See parameter 21-12 Ext. 1 Maximum Reference for details.
------------------	--	---

21-53 Ext. 3 Reference Source

Option: **Function:**

		See parameter 21-13 Ext. 1 Reference Source for details.
[0] *	No function	
[1]	Analog Input 53	
[2]	Analog Input 54	
[7]	Pulse input 29	
[8]	Pulse input 33	
[20]	Digital pot.meter	
[21]	Analog input X30/11	
[22]	Analog input X30/12	
[23]	Analog Input X42/1	
[24]	Analog Input X42/3	
[25]	Analog Input X42/5	
[30]	Ext. Closed Loop 1	
[31]	Ext. Closed Loop 2	
[32]	Ext. Closed Loop 3	

21-54 Ext. 3 Feedback Source

Option: **Function:**

		See parameter 21-14 Ext. 1 Feedback Source for details.
[0] *	No function	
[1]	Analog Input 53	
[2]	Analog Input 54	
[3]	Pulse input 29	
[4]	Pulse input 33	
[7]	Analog Input X30/11	
[8]	Analog Input X30/12	
[9]	Analog Input X42/1	
[10]	Analog Input X42/3	
[11]	Analog Input X42/5	
[100]	Bus Feedback 1	
[101]	Bus Feedback 2	

21-54 Ext. 3 Feedback Source

Option: **Function:**

[102]	Bus feedback 3	
[110]	Air Pres. to Flow	

21-55 Ext. 3 Setpoint

Range: **Function:**

0 ExtPID3Unit*	[par. 21-51 - par. 21-52 ExtPID3Unit]	See parameter 21-15 Ext. 1 Setpoint for details.
----------------	--	--

21-56 Ext. 3 PID Conversion

Select the conversion method for integrated PID 3.

Option: **Function:**

[0] *	Linear	
[1]	Square root	
[2]	Pressure to temperature	

21-57 Ext. 3 Reference [Unit]

Range: **Function:**

0 ExtPID3Unit*	[-999999.999 - 999999.999 ExtPID3Unit]	See parameter 21-17 Ext. 1 Reference [Unit] for details.
----------------	--	--

21-58 Ext. 3 Feedback [Unit]

Range: **Function:**

0 ExtPID3Unit*	[-999999.999 - 999999.999 ExtPID3Unit]	See parameter 21-18 Ext. 1 Feedback [Unit] for details.
----------------	--	---

21-59 Ext. 3 Output [%]

Range: **Function:**

0 %*	[0 - 100 %]	See parameter 21-19 Ext. 1 Output [%] for details.
------	-------------	--

3.17.8 21-6* Closed Loop 3 PID

21-60 Ext. 3 Normal/Inverse Control

Option: **Function:**

		See parameter 21-20 Ext. 1 Normal/Inverse Control for details.
[0] *	Normal	
[1]	Inverse	

21-61 Ext. 3 Proportional Gain

Range: **Function:**

0.01*	[0 - 10]	See parameter 21-21 Ext. 1 Proportional Gain for details.
-------	----------	---

21-62 Ext. 3 Integral Time

Range: **Function:**

10000 s*	[0.01 - 10000 s]	See parameter 21-22 Ext. 1 Integral Time for details.
----------	------------------	---

3

21-63 Ext. 3 Differentiation Time		
Range:	Function:	
0 s*	[0 - 10 s]	See parameter 21-23 Ext. 1 Differentiation Time for details.

21-64 Ext. 3 Dif. Gain Limit		
Range:	Function:	
5*	[1 - 50]	See parameter 21-24 Ext. 1 Dif. Gain Limit for details.

21-70 Refrigerant

Select the refrigerant for the compressor application. This parameter is important for option [2] Pressure to temperature in parameter 21-16 Ext. 1 PID Conversion, parameter 21-36 Ext. 2 PID Conversion, and parameter 21-56 Ext. 3 PID Conversion to yield correct results.

Option:	Function:	
[0]	User defined	
[1]	R12	
[2]	R22	
[3]	R134a	
[4]	R502	
[5]	R717	
[6]	R13	
[7]	R13b1	
[8]	R23	
[9]	R500	
[10]	R503	
[11]	R114	
[12]	R142b	
[14]	R32	
[15]	R227	
[16]	R401A	
[17]	R507	
[18]	R402A	
[19] *	R404A	
[20]	R407C	
[21]	R407A	
[22]	R407B	
[23]	R410A	
[24]	R170	
[25]	R290	
[26]	R600	
[27]	R600a	
[28]	R744	
[29]	R1270	
[30]	R417A	
[31]	R422A	
[32]	R413A	
[33]	Isceon 29	
[34]	R427A	
[35]	R438A	
[36]	Opteon XP10	
[37]	R407F	
[38]	R1234ze	

21-70 Refrigerant		
Select the refrigerant for the compressor application. This parameter is important for option [2] Pressure to temperature in parameter 21-16 Ext. 1 PID Conversion, parameter 21-36 Ext. 2 PID Conversion, and parameter 21-56 Ext. 3 PID Conversion to yield correct results.		
Option:	Function:	
[39]	R1234yf	

21-71 User Defined Refrigerant A1		
Use this parameter to program non-standard refrigerants. Set the coefficient A1 for the refrigerant.		
Range:	Function:	
10*	[8 - 12]	

21-72 User Defined Refrigerant A2		
Use this parameter to program non-standard refrigerants. Set the coefficient A2 for the refrigerant.		
Range:	Function:	
-2250*	[-3000 - -1500]	

21-73 User Defined Refrigerant A3		
Use this parameter to program non-standard refrigerants. Set the coefficient A3 for the refrigerant.		
Range:	Function:	
250*	[200 - 300]	

3.18 Parameters: 22-** Application Functions

This group contains parameters for monitoring refrigeration applications.

22-00 External Interlock Delay		
Range:	Function:	
0 s* [0 - 600 s]	Only relevant if 1 of the digital inputs in parameter group 5-1* Digital Inputs has been programmed for [7] External Interlock. The external interlock timer introduces a delay after the signal has been removed from the digital input programmed for external interlock, before reaction takes place.	

3.18.1 22-1* Air Pres. to Flow

Parameter group for air pressure monitoring functions.

22-10 Air Pressure to Flow Signal source		
Select the signal source for measuring the pressure difference. The frequency converter uses the difference to calculate the airflow. Use scaling for analog inputs.		
Option:	Function:	
[0] *	No function	
[1]	Analog Input 53	
[2]	Analog Input 54	
[7]	Analog Input X30/11	
[8]	Analog Input X30/12	
[9]	Analog Input X42/1	

22-10 Air Pressure to Flow Signal source		
Select the signal source for measuring the pressure difference. The frequency converter uses the difference to calculate the airflow. Use scaling for analog inputs.		
Option:	Function:	
[10]	Analog Input X42/3	
[11]	Analog Input X42/5	

22-11 Air Pressure to Flow Fan k-factor		
Enter the k-factor of the fan. The k-factor is specified by the fan manufacturer. The frequency converter uses the k-factor for the airflow calculation.		
Range:	Function:	
1000*	[1 - 10000]	

22-12 Air Pressure to Flow Air density		
Enter the air density. The frequency converter uses the air density for the airflow calculation.		
Range:	Function:	
1.2*	[0.001 - 10]	

22-13 Air Pressure to Flow Fan flow unit		
Select the unit for showing the calculated airflow.		
Option:	Function:	
[0] *	m ³ /h	
[1]	m ³ /s	

3.18.2 22-2* No-Flow Detection

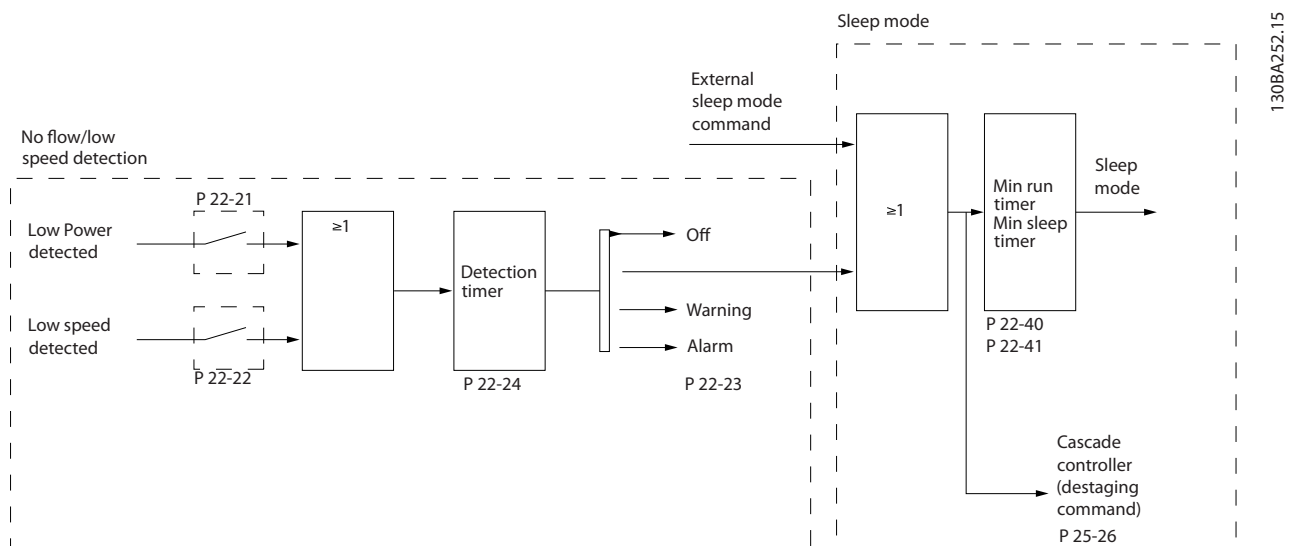

Illustration 3.49 No-flow Detection

The frequency converter includes functions for detecting if the load conditions in the system allow the motor to be stopped:

- Low-power detection.
- Low-speed detection.

One of these 2 signals must be active for a set time (*parameter 22-24 No-Flow Delay*) before selected action takes place. Possible actions to select (*parameter 22-23 No-Flow Function*):

- No action
- Warning
- Alarm
- Sleep mode

No-flow detection

This function is used for detecting a no-flow situation in compressor systems where all valves can be closed. Can be used both when controlled by the integrated PI controller in the frequency converter or an external PI controller. Program the actual configuration in *parameter 1-00 Configuration Mode*.

Configuration mode for

- Integrated PI controller: Closed loop.
- External PI controller: Open loop.

NOTICE

Carry out no-flow tuning before setting the PI controller parameters.

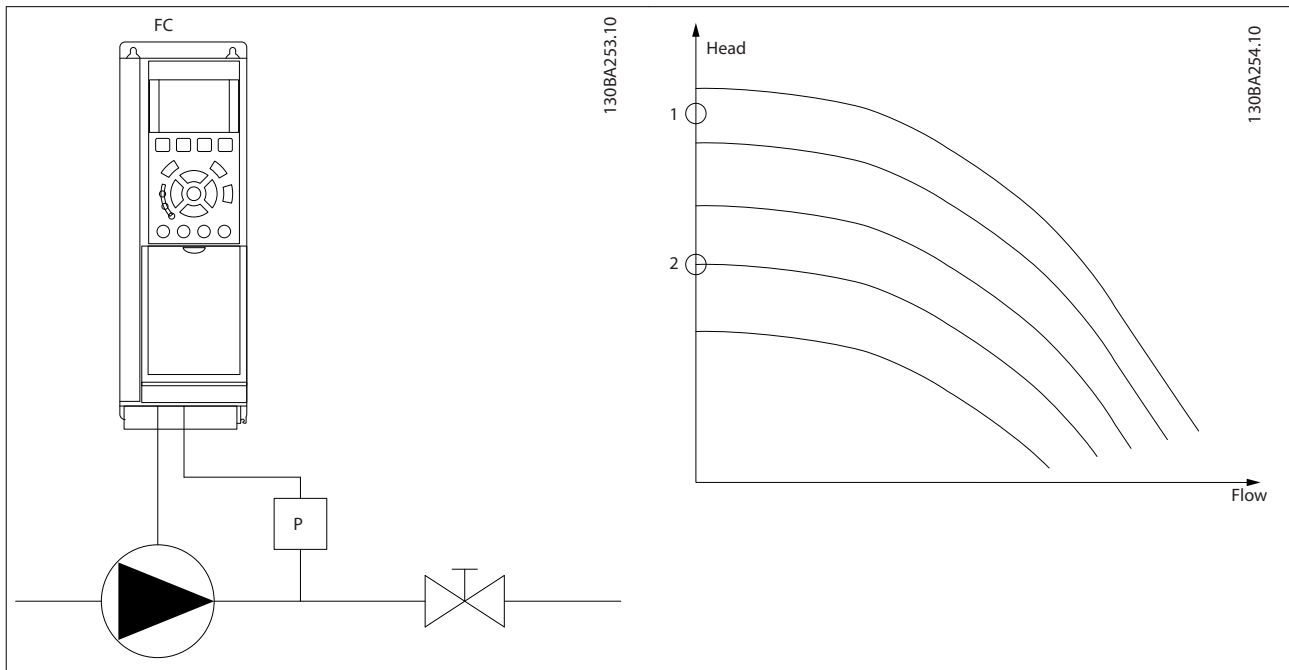

Table 3.19 No-flow Detection

No-flow detection is based on the measurement of speed and power. For a certain speed, the frequency converter calculates the power at no-flow.

This coherence is based on the adjustment of 2 sets of speed and associated power at no-flow. Monitoring power enables detection of no-flow conditions in systems with fluctuating suction pressure, or of the compressor having a flat characteristic towards low speed.

Base the 2 sets of data on measurement of power at approximately 50% and 85% of maximum speed with the valves closed. The data is programmed in *parameter group 22-3* No-Flow Power Tuning*. It is also possible to run a [0] Low Power Auto Set Up (*parameter 22-20 Low Power Auto Set-up*) automatically stepping through the commissioning process and storing the data measured. Set the frequency converter for [0] Open Loop in *parameter 1-00 Configuration Mode*, when carrying out the auto set-up, see *parameter group 22-3* No-Flow Power Tuning No-flow Power Tuning*.

NOTICE

If to use the integrated PI controller, carry out no-flow tuning before setting the PI controller parameters.

Low-speed detection

Low-speed detection gives a signal if the motor operates with minimum speed as set in *parameter 4-11 Motor Speed Low Limit [RPM]* or *parameter 4-12 Motor Speed Low Limit [Hz]*. Actions are common with no-flow detection (individual selection not possible).

The use of low-speed detection is not limited to systems with a no-flow situation. Low-speed detection can be used in any system where operation at minimum speed allows a stop of the motor until the load calls for a speed higher than minimum speed. This could, for example, be in systems with fans and compressors.

NOTICE

In compressor systems, ensure that the minimum speed in *parameter 4-11 Motor Speed Low Limit [RPM]* or *parameter 4-12 Motor Speed Low Limit [Hz]* is set high enough for detection as the compressor can run with a rather high speed even with valves closed.

Dry-pump detection

If the pump has run dry (low power consumption-high speed), no-flow detection can also be used for detecting. Can be used with both the integrated PI controller and an external PI controller.

The condition for dry-pump signal:

- Power consumption below no-flow level.

and

- Pump running at maximum speed or maximum reference open loop, whichever is lowest.

The signal must be active for a set time (*parameter 22-27 Dry Pump Delay*) before the selected action takes place.

Possible actions to select (*parameter 22-26 Dry Pump Function*):

- Warning
- Alarm

Enable and commission no-flow detection in *parameter 22-23 No-Flow Function* and *parameter group 22-3* No-Flow Power Tuning*.

22-20 Low Power Auto Set-up	
Start of auto set-up of power data for no-flow power tuning.	
Option:	Function:
[0] * Off	
[1] Enabled	<p>NOTICE Do the auto set-up when the system has reached normal operating temperature.</p> <p>NOTICE It is important that <i>parameter 4-13 Motor Speed High Limit [RPM]</i> or <i>parameter 4-14 Motor Speed High Limit [Hz]</i> is set to the maximum operational speed of the motor.</p> <p>It is important to do the auto set-up before configuring the integrated PI controller as settings are reset when changing from closed loop to open loop in <i>parameter 1-00 Configuration Mode</i>.</p> <p>NOTICE Carry out the tuning with the same settings in <i>parameter 1-03 Torque Characteristics</i> as for operation after the tuning.</p> <p>An auto set-up sequence is activated, automatically setting speed to approximately 50% and 85% of nominal motor speed (<i>parameter 4-13 Motor Speed High Limit [RPM]</i>, <i>parameter 4-14 Motor Speed High Limit [Hz]</i>). At those 2 speeds, the power consumption is automatically measured and stored.</p> <p>Before enabling auto set-up:</p> <ol style="list-style-type: none"> 1. Close valve(s) to create a no-flow condition. 2. Set the frequency converter to open loop (<i>parameter 1-00 Configuration Mode</i>). It is important also to set <i>parameter 1-03 Torque Characteristics</i>.

22-21 Low Power Detection	
Option:	Function:
[0] * Disabled	
[1] Enabled	To set the parameters in <i>parameter group 22-3* No-Flow Power Tuning</i> for proper operation, carry out the low-power detection commissioning.

22-22 Low Speed Detection	
Option:	Function:
[0] * Disabled	
[1] Enabled	Detects when the motor operates with a speed as set in <i>parameter 4-11 Motor Speed Low Limit</i>

22-22 Low Speed Detection	
Option:	Function:
	[RPM] or <i>parameter 4-12 Motor Speed Low Limit [Hz]</i> .

22-23 No-Flow Function	
Common actions for low-power detection and low-speed detection (individual selections not possible).	
Option:	Function:
[0] * Off	<p>NOTICE Do not set <i>parameter 14-20 Reset Mode</i>, to [13] <i>Infinite auto reset</i>, when <i>parameter 22-23 No-Flow Function</i> is set to [3] <i>Alarm</i>. Doing so causes the frequency converter to continuously cycle between running and stopping when a no-flow condition is detected.</p> <p>NOTICE Disable the automatic bypass function of the bypass if the frequency converter is equipped with a constant-speed bypass with an automatic bypass function starting the bypass if the frequency converter experiences a persistent alarm condition, and [3] <i>Alarm</i> is selected as the no-flow function.</p>
[1] Sleep Mode	The frequency converter enters sleep mode and stops when a no-flow condition is detected. See <i>parameter group 22-4* Sleep Mode</i> for programming options for sleep mode.
[2] Warning	The frequency converter continues to run, but activates a no-flow warning (<i>warning 92, NoFlow</i>). A digital output or a serial communication bus can communicate a warning to other equipment.
[3] Alarm	The frequency converter stops running and activates a no-flow alarm (<i>alarm 92, NoFlow</i>). A frequency converter digital output or a serial communication bus can communicate an alarm to other equipment.

22-24 No-Flow Delay	
Range:	Function:
10 s* [1 - 600 s]	Set the time that low power/low speed must stay detected to activate signal for actions. If detection disappears before the timer runs out, the timer is reset.

22-26 Dry Pump Function		
Select the action for dry-pump operation.		
Option:	Function:	
[0] *	Off	
[1]	Warning	<p>NOTICE</p> <p>To use dry-pump detection:</p> <ol style="list-style-type: none"> 1. Enable low-power detection in <i>parameter 22-21 Low Power Detection</i>. 2. Commission low-power detection using either <i>parameter group 22-3* No-flow Power Tuning No Flow Power Tuning</i>, or <i>parameter 22-20 Low Power Auto Set-up</i>. <p>NOTICE</p> <p>Do not set <i>parameter 14-20 Reset Mode</i> to [13] <i>Infinite auto reset</i>, when <i>parameter 22-26 Dry Pump Function</i> is set to [2] <i>Alarm</i>. Doing so causes the frequency converter to continuously cycle between running and stopping when a dry-pump condition is detected.</p> <p>NOTICE</p> <p>For frequency converters with constant-speed bypass If an automatic bypass function starts the bypass at persistent alarm conditions, disable the automatic bypass function, if [2] <i>Alarm</i> or [3] <i>Man. Reset Alarm</i> is selected as the dry-pump function.</p> <p>The frequency converter continues to run, but activates a dry-pump warning (<i>warning 93, Dry pump</i>). A frequency converter digital output or a serial communication bus can communicate a warning to other equipment.</p>
[2]	Alarm	The frequency converter stops running and activates a dry-pump alarm (<i>alarm 93, Dry pump</i>). A frequency converter digital output or a serial communication bus can communicate an alarm to other equipment.
[3]	Man. Reset Alarm	The frequency converter stops running and activates a dry-pump alarm (<i>alarm 93, Dry pump</i>). A frequency converter digital output or a serial communication bus can communicate an alarm to other equipment.
[4]	Stop and Trip	

22-27 Dry Pump Delay		
Range:	Function:	
10 s* [0 - 600 s]	<p>Defines for how long the dry-pump condition must be active before activating a warning or an alarm.</p> <p>The frequency converter waits for the no-flow delay time (<i>parameter 22-24 No-Flow Delay</i>) to expire before the timer for the dry-pump delay starts.</p>	

3.18.3 22-3* No-flow Power Tuning

If auto set-up is disabled in *parameter 22-20 Low Power Auto Set-up*, the tuning sequence is:

NOTICE

Set *parameter 1-03 Torque Characteristics* before tuning takes place.

1. Close the main valve to stop flow.
2. Run with motor until the system has reached normal operating temperature.
3. Press [Hand On] and adjust speed for approximately 85% of rated speed. Note the exact speed.
4. Read power consumption either by looking for actual power in the data line in the LCP or by viewing 1 of the following parameters:
 - 4a *Parameter 16-10 Power [kW]*.
 - or
 - 4b *Parameter 16-11 Power [hp]* in the Main Menu.

Note the power readout.
5. Change speed to approximately 50% of rated speed. Note the exact speed.
6. Read power consumption either by looking for actual power in the data line in the LCP or by viewing 1 of the following parameters:
 - 6a *Parameter 16-10 Power [kW]*.
 - or
 - 6b *Parameter 16-11 Power [hp]* in the Main Menu.

Note the power readout.
7. Program the speeds used in:
 - 7a *Parameter 22-32 Low Speed [RPM]*.
 - 7b *Parameter 22-33 Low Speed [Hz]*.
 - 7c *Parameter 22-36 High Speed [RPM]*.
 - 7d *Parameter 22-37 High Speed [Hz]*.
8. Program the associated power values in:

- 8a Parameter 22-34 Low Speed Power [kW].
- 8b Parameter 22-35 Low Speed Power [HP].
- 8c Parameter 22-38 High Speed Power [kW].
- 8d Parameter 22-39 High Speed Power [HP].

9. Switch back with [Auto On] or [Off].

22-30 No-Flow Power		
Range:		Function:
0 kW*	[0 - 1000 kW]	Readout of calculated no-flow power at actual speed. If power drops to the display value, the frequency converter considers the condition as a no-flow situation.

22-31 Power Correction Factor		
Range:		Function:
100 % *	[1 - 400 %]	Make corrections to the calculated power in <i>parameter 22-30 No-Flow Power</i> . If no-flow is detected when it should not be detected, decrease the setting. However, if no-flow is not detected when it should be detected, increase the setting to above 100%.

22-32 Low Speed [RPM]		
Range:		Function:
Size related*	[0 - par. 22-36 RPM]	To be used if <i>parameter 0-02 Motor Speed Unit</i> is set to [0] RPM (parameter not visible if [1] Hz is selected). Set used speed for the 50% level. This function is used for storing values necessary for tuning no-flow detection.

22-33 Low Speed [Hz]		
Range:		Function:
Size related*	[0 - par. 22-37 Hz]	To be used if <i>parameter 0-02 Motor Speed Unit</i> is set for [1] Hz (parameter not visible if [0] RPM is selected). Set used speed for the 50% level. The function is used for storing values necessary for tuning no-flow detection.

22-34 Low Speed Power [kW]		
Range:		Function:
Size related*	[0 - 5.50 kW]	To be used if <i>parameter 0-03 Regional Settings</i> is set for [0] International (parameter not visible if [1] North America is selected). Set power consumption at 50% speed level. This function is used for storing values necessary for tuning no-flow detection.

22-35 Low Speed Power [HP]		
Range:		Function:
Size related*	[0 - 7.50 hp]	To be used if <i>parameter 0-03 Regional Settings</i> is set for [1] North America

22-35 Low Speed Power [HP]		
Range:		Function:
		(parameter not visible if [0] International is selected). Set power consumption at 50% speed level. This function is used for storing values necessary for tuning no-flow detection.

22-36 High Speed [RPM]		
Range:		Function:
Size related*	[0 - par. 4-13 RPM]	To be used if <i>parameter 0-02 Motor Speed Unit</i> is set for [0] RPM (parameter not visible if [1] Hz is selected). Set used speed for the 85% level. The function is used for storing values necessary for tuning no-flow detection.

22-37 High Speed [Hz]		
Range:		Function:
Size related*	[0 - par. 4-14 Hz]	To be used if <i>parameter 0-02 Motor Speed Unit</i> is set for [1] Hz (parameter not visible if [0] RPM is selected). Set used speed for the 85% level. The function is used for storing values necessary for tuning no-flow detection.

22-38 High Speed Power [kW]		
Range:		Function:
Size related*	[0 - 5.50 kW]	To be used, if <i>parameter 0-03 Regional Settings</i> is set for [0] International (parameter not visible if [1] North America is selected). Set power consumption at 85% speed level. This function is used for storing values necessary for tuning no-flow detection.

22-39 High Speed Power [HP]		
Range:		Function:
Size related*	[0 - 7.50 hp]	To be used if <i>parameter 0-03 Regional Settings</i> is set for [1] North America (parameter not visible if [0] International is selected). Set power consumption at 85% speed level. This function is used for storing values necessary for tuning no-flow detection.

3.18.4 22-4* Sleep Mode

If the load on the system allows for stop of the motor and the load is monitored, the motor can be stopped by activating the sleep mode function. This is not a normal stop command, but ramps the motor down to 0 RPM and stops energising the motor. When in sleep mode, certain

conditions are monitored to find out when load has been applied to the system again.

Sleep mode can be activated either from the no-flow detection/minimum speed detection (must be programmed via parameters for no-flow detection, see the signal flow-diagram in *parameter group 22-2**, *No-Flow Detection*) or via an external signal applied to 1 of the digital inputs (must be programmed via the parameters for configuration of the digital inputs, *parameter group 5-1* Digital Inputs* selecting [66] *Sleep Mode*). Sleep mode is activated only when no wake-up conditions are present. To enable use of, for example, an electro-mechanical flow switch to detect a no-flow condition and activate sleep mode, the action takes place at the raising edge of the external signal applied (otherwise the frequency converter would stay in sleep mode as the signal would be steadily connected).

NOTICE

If sleep mode is to be based on no-flow detection/minimum speed, select [1] *Sleep Mode* in *parameter 22-23 No-Flow Function*.

If *parameter 25-30 Destage At No-Flow* is set for [1] *Enabled*, activating sleep mode sends a command to the cascade controller (if enabled) to start de-staging of lag pumps (fixed speed) before stopping the lead pump (variable speed).

When entering sleep mode, the lower status line in the LCP shows *Sleep Mode*.

See also signal flow chart in *parameter group 22-2* No-Flow Detection*.

There are the following ways of using the sleep mode function:

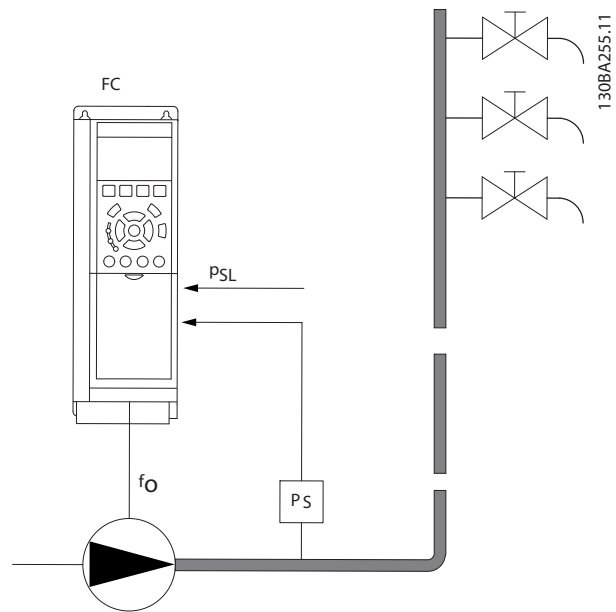

Illustration 3.50 Sleep Mode Function

1) Systems where the integrated PI controller is used for controlling pressure or temperature, for example boost systems with a pressure feedback signal applied to the frequency converter from a pressure transducer. Set *parameter 1-00 Configuration Mode* for [3] *Closed Loop* and configure the PI controller configured for desired reference and feedback signals.
Example: Boost system.

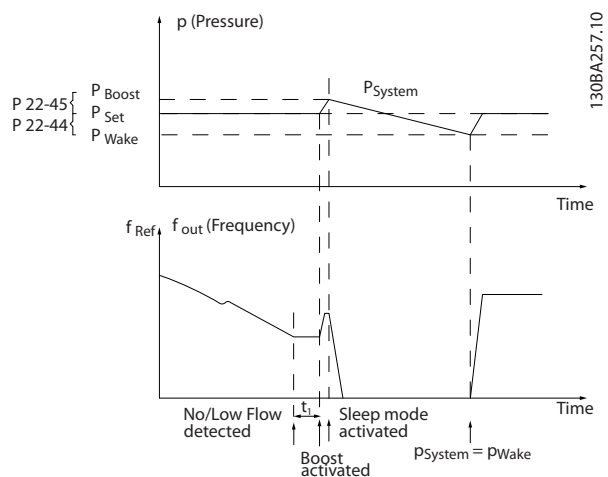

Illustration 3.51 Boost System

If no-flow is detected, the frequency converter increases the setpoint for pressure to ensure a slight overpressure in the system (boost to be set in *parameter 22-45 Setpoint Boost*).

The feedback from the pressure transducer is monitored, and when this pressure has dropped with a set percentage below the normal setpoint for pressure (P_{set}), the motor

ramps up again and the pressure reaches the set value (P_{set}).

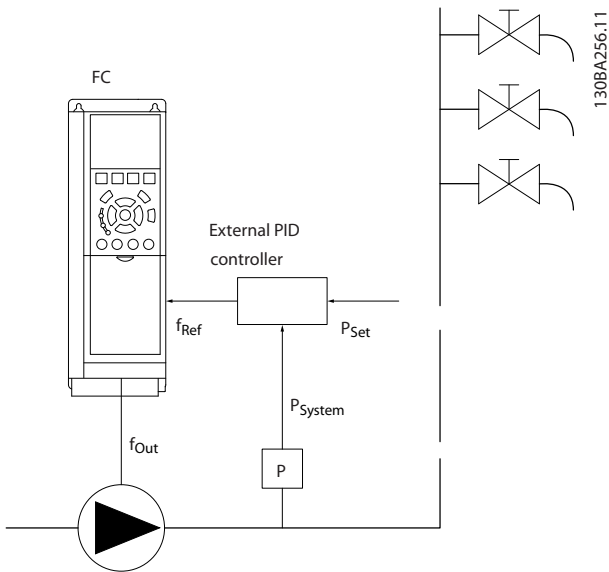

Illustration 3.52 Boost System

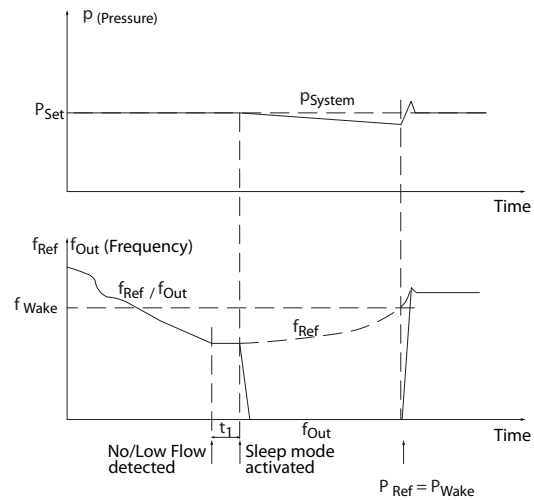

Illustration 3.53 Boost System

2) In systems where the pressure or temperature is controlled by an external PI controller, the wake-up conditions cannot be based on feedback from the pressure/temperature transducer as the setpoint is not known. In the example with a boost system, desired pressure P_{set} is not known. Set *parameter 1-00 Configuration Mode* to [0] Open Loop. Example: Boost system.

When low power or low speed is detected, the motor is stopped, but the reference signal (f_{ref}) from the external controller is still monitored. Because of the low pressure created, the controller increases the reference signal to gain pressure. When the reference signal has reached a set value, f_{wake} , the motor restarts.

The speed is set manually by an external reference signal (remote reference). Use default settings (*parameter group 22-3* No-Flow Power Tuning*) for tuning of the no-flow function.

	Internal PI controller (parameter 1-00 Configuration Mode: Closed loop)		External PI controller or manual control (parameter 1-00 Configuration Mode: Open loop)	
	Sleep mode	Wake up	Sleep mode	Wake up
No-flow detection (pumps only)	Yes	-	Yes (except manual setting of speed)	-
Low speed detection	Yes	-	Yes	-
External signal	Yes	-	Yes	-
Pressure/temperature (transmitter connected)	-	Yes	-	No
Output frequency	-	No	-	Yes

Table 3.20 Configuration Overview

NOTICE

Sleep mode is not active when local reference is active (press the navigation keys to set speed manually). See *parameter 3-13 Reference Site*. Does not work in hand-on mode. Carry out auto set-up in open loop before setting input/output in closed loop.

22-40 Minimum Run Time		
Range:	Function:	
10 s*	[0 - 600 s]	Set the minimum running time for the motor after a start command (digital input or fieldbus) before entering sleep mode.

22-41 Minimum Sleep Time		
Range:		Function:
10 s*	[0 - 600 s]	Set the minimum time for staying in sleep mode. This setting overrides any wake-up conditions.

22-42 Wake-up Speed [RPM]		
Range:		Function:
Size related*	[par. 4-11 - par. 4-13 RPM]	To be used if <i>parameter 0-02 Motor Speed Unit</i> has been set for [0] RPM (parameter not visible if [1] Hz is selected). Only to be used if <i>parameter 1-00 Configuration Mode</i> is set for [0] Open loop and an external controller applies speed reference. Set the reference speed at which the sleep mode should be canceled.

22-43 Wake-up Speed [Hz]		
Range:		Function:
Size related*	[par. 4-12 - par. 4-14 Hz]	To be used if <i>parameter 0-02 Motor Speed Unit</i> has been set for [1] Hz (parameter not visible if [0] RPM is selected). Only to be used if <i>parameter 1-00 Configuration Mode</i> is set for [0] Open Loop and speed reference is applied by an external controller controlling the pressure. Set the reference speed at which the sleep mode should be canceled.

22-44 Wake-up Ref./FB Difference		
Range:		Function:
10 % *	[0 - 100 %]	Only to be used if <i>parameter 1-00 Configuration Mode</i> is set for [3] Process Closed Loop and the integrated PI controller is used for controlling the pressure. Set the pressure drop allowed in percentage of setpoint for the pressure (P_{set}) before canceling the sleep mode.

22-45 Setpoint Boost		
Range:		Function:
0 % *	[-100 - 100 %]	Only to be used if <i>parameter 1-00 Configuration Mode</i> is set to [3] Closed Loop and the integrated PI controller is used. In systems with, for example, constant pressure control, it is advantageous to increase the system pressure before the motor is stopped. This extends the time in which the motor is stopped and helps to avoid frequent start/stop. Set the overpressure/overtemperature in percentage of setpoint for the pressure (P_{set})/ temperature before entering sleep mode. If set to 5%, the boost pressure is $P_{set} \times 1.05$. The negative values can be used, for example, in cooling tower control where a negative change is needed.

22-46 Maximum Boost Time		
Range:		Function:
60 s*	[0 - 600 s]	Only to be used if <i>parameter 1-00 Configuration Mode</i> is set to [3] Process Closed Loop and the integrated PI controller is used for controlling the pressure. Set the maximum time for which boost mode is allowed. If the set time is exceeded, sleep mode is entered, not waiting for the set boost pressure to be reached.

3.18.5 22-5* End of Curve

The end-of-curve conditions occur when a pump is yielding a too large volume to ensure the set pressure. This can occur if there is a leakage in the distribution pipe system.

The frequency converter initiates the function selected in *parameter 22-50 End of Curve Function* in the following conditions:

- The frequency converter is running at maximum speed (*parameter 4-13 Motor Speed High Limit [RPM]* or *parameter 4-14 Motor Speed High Limit [Hz]*).
- The feedback signal is less than the pressure setpoint by a value that is equal to or exceeds 2.5% of the value in *parameter 3-03 Maximum Reference*.
- The conditions are active for a time set in *parameter 22-51 End of Curve Delay*.

It is possible to get a signal on 1 of the digital outputs by selecting [192] End of Curve in *parameter group 5-3* Digital Outputs* and/or *parameter group 5-4* Relays*. The signal is present, when an end-of-curve condition occurs and the selection in *parameter 22-50 End of Curve Function* is different from [0] Off. The end-of-curve function can only be used when operating with the built-in PID controller ([3] Closed loop in *parameter 1-00 Configuration Mode*).

22-50 End of Curve Function		
Option:	Function:	
		<p>NOTICE Automatic restart resets the alarm and restarts the system.</p> <p>NOTICE Do not set <i>parameter 14-20 Reset Mode</i>, to [13] <i>Infinite auto reset</i>, when <i>parameter 22-50 End of Curve Function</i> is set to [2] <i>Alarm</i>. Doing so causes the frequency converter to continuously cycle between running and stopping when an end-of-curve condition is detected.</p> <p>NOTICE If the frequency converter is equipped with a constant speed bypass with an automatic bypass function that starts the bypass if the frequency converter experiences a persistent alarm condition, be sure to disable the automatic bypass function, if [2] <i>Alarm</i> or [3] <i>Man. Reset Alarm</i> is selected as the end-of-curve function.</p>
[0]	Off	End-of-curve monitoring is not active.
[1]	Warning	The frequency converter continues to run, but activates an end-of-curve warning (<i>warning 94, End of curve</i>). A frequency converter digital output or a serial communication bus can communicate a warning to other equipment.
[2]	Alarm	The frequency converter stops running and activates an end-of-curve alarm (<i>alarm 94, End of curve</i>). A frequency converter digital output or a serial communication bus can communicate an alarm to other equipment.
[3]	Man. Reset Alarm	The frequency converter stops running and activates an end-of-curve alarm (<i>alarm 94, End of curve</i>). A frequency converter digital output or a fieldbus can communicate an alarm to other equipment.
[4]	Stop and Trip	

22-51 End of Curve Delay		
Range:	Function:	
10 s* [0 - 600 s]		When an end-of-curve condition is detected, a timer is activated. When the time set in this parameter expires, and the end-of-curve condition is steady during the entire period, the function set in <i>parameter 22-50 End of Curve</i>

22-51 End of Curve Delay		
Range:	Function:	
		<i>Function</i> is activated. If the condition disappears before the timer expires, the timer is reset.

3.18.6 22-6* Broken Belt Detection

The broken-belt detection can be used in both closed-loop and open-loop systems for pumps, fans, and compressors. If the estimated motor torque is below the broken-belt torque value (*parameter 22-61 Broken Belt Torque*), and the frequency converter output frequency is above or equal to 15 Hz, the broken-belt function (*parameter 22-60 Broken Belt Function*) is performed.

22-60 Broken Belt Function		
Selects the action to be performed if the broken-belt condition is detected.		
Option:	Function:	
		<p>NOTICE Do not set <i>parameter 14-20 Reset Mode</i> to [13] <i>Infinite auto reset</i>, when <i>parameter 22-60 Broken Belt Function</i> is set to [2] <i>Trip</i>. Doing so causes the frequency converter to continuously cycle between running and stopping when a broken-belt condition is detected.</p> <p>NOTICE For frequency converters with constant-speed bypass. If an automatic bypass function starts the bypass at persistent alarm conditions, disable the bypass's automatic bypass function if [2] <i>Alarm</i> or [3] <i>Man. Reset Alarm</i> is selected as the broken-belt function.</p>
[0] *	Off	
[1]	Warning	The frequency converter continues to run, but activates a broken-belt warning (<i>warning 95, Broken belt</i>). A frequency converter digital output or a serial communication bus can communicate a warning to other equipment.
[2]	Trip	The frequency converter stops running and activates a broken-belt alarm (<i>alarm 95, Broken belt</i>). A frequency converter digital output or a serial communication bus can communicate an alarm to other equipment.

22-61 Broken Belt Torque		
Range:	Function:	
10 %* [0 - 100 %]		Sets the broken-belt torque as a percentage of the rated motor torque.

22-62 Broken Belt Delay		
Range:	Function:	
10 s [0 - 600 s]	Sets the time for which the broken belt conditions must be active before carrying out the action selected in <i>parameter 22-60 Broken Belt Function</i> .	

3.18.7 22-7* Short Cycle Protection

When controlling refrigeration compressors, often there is a need for limiting the numbers of starts. One way to do this is to ensure a minimum run time (time between a start and a stop) and a minimum interval between starts. This means that any normal stop command can be overridden by the minimum run time function (*parameter 22-77 Minimum Run Time*) and any normal start command (start/jog/freeze) can be overridden by the interval between starts function (*parameter 22-76 Interval between Starts*).

None of the 2 functions are active if hand-on or off modes have been activated via the LCP. If selecting hand-on or off, the 2 timers are reset to 0, and not start counting until *Auto* is pressed and an active start command applied.

NOTICE

A coast command or missing run permissive signal override both minimum run time and interval between starts functions.

22-75 Short Cycle Protection		
Option:	Function:	
[0] *	Disabled	Timer set in <i>parameter 22-76 Interval between Starts</i> is disabled.
[1]	Enabled	Timer set in <i>parameter 22-76 Interval between Starts</i> is enabled.

22-76 Interval between Starts		
Range:	Function:	
300 s* [par. 22-77 - 3600 s]	Sets the minimum time between 2 starts. Any normal start command (start/jog/freeze) is disregarded until the timer has expired.	

22-77 Minimum Run Time		
Range:	Function:	
0 s* [0 - par. 22-76 s]	<p>NOTICE Does not work in pack control mode.</p> <p>Sets the minimum run time after a normal start command (start/jog/freeze). Any normal stop command is disregarded until the set time has expired. The timer starts counting following a normal start command (start/jog/freeze).</p>	

22-77 Minimum Run Time		
Range:	Function:	
	A coast (inverse) or an external interlock command overrides the timer.	

22-78 Minimum Run Time Override		
Option:	Function:	
[0] *	Disabled	
[1]	Enabled	

22-79 Minimum Run Time Override Value		
Range:	Function:	
0 ProcessCtrlUnit* [-999999.999 - 999999.999 ProcessCtrlUnit]		

3.18.8 22-8* Flow Compensation

Sometimes it is not possible for a pressure transducer to be placed at a remote point in the system, and it can only be placed close to the fan/pump outlet. Flow compensation operates by adjusting the setpoint according to the output frequency, which is almost proportional to flow, thus compensating for higher losses at higher flow rates.

H_{DESIGN} (required pressure) is the setpoint for closed-loop (PI) operation of the frequency converter and is set as for closed-loop operation without flow compensation.

It is recommended to use slip compensation and RPM as unit.

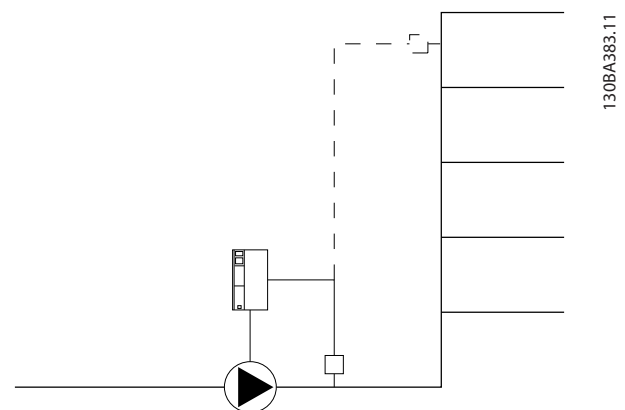

Illustration 3.54 Flow Compensation

NOTICE

When flow compensation is used with the cascade controller (*parameter group 25-** Cascade Pack Controller*), the actual setpoint does not depend on speed (flow), but on the number of pumps cut in. See *Illustration 3.55*:

There are 2 methods which can be employed, depending on whether or not the speed at system design working point is known.

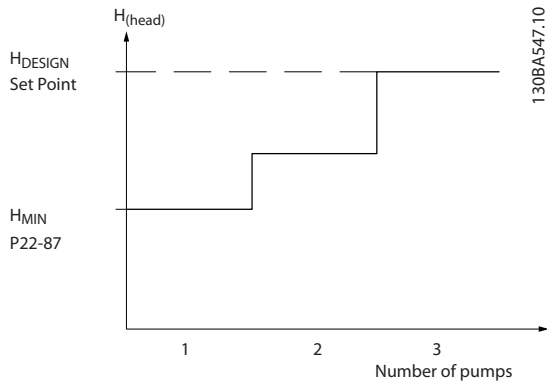

Illustration 3.55 Number of Pumps

Parameter used	Speed at design point KNOWN	Speed at design point UNKNOWN	Cascade controller
Parameter 22-80 Flow Compensation	+	+	+
Parameter 22-81 Square-linear Curve Approximation	+	+	-
Parameter 22-82 Work Point Calculation	+	+	-
Parameter 22-83 Speed at No-Flow [RPM]/ Parameter 22-84 Speed at No-Flow [Hz]	+	+	-
Parameter 22-85 Speed at Design Point [RPM]/ Parameter 22-86 Speed at Design Point [Hz]	+	-	-
parameter 22-87 Pressure at No-Flow Speed	+	+	+
Parameter 22-88 Pressure at Rated Speed	-	+	-
Parameter 22-89 Flow at Design Point	-	+	-
Parameter 22-90 Flow at Rated Speed	-	+	-

Table 3.21 Number of Pumps

22-80 Flow Compensation		
Option:	Function:	
[0] *	Disabled	Setpoint compensation not active.
[1]	Enabled	Setpoint compensation is active. Enabling this parameter allows the flow-compensated setpoint operation.

22-81 Square-linear Curve Approximation		
Range:	Function:	
100 %*	[0 - 100 %]	<p>NOTICE</p> <p>Not visible when running in pack control mode.</p> <p>Example 1</p> <p>Adjustment of this parameter allows the shape of the control curve to be adjusted.</p> <p>0 = Linear</p> <p>100% = Ideal shape (theoretical).</p>

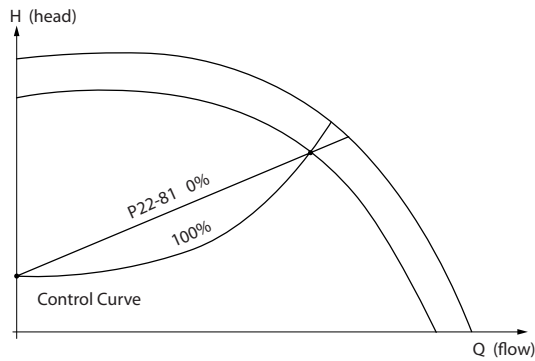

Illustration 3.56 Square-Linear Curve Approximation

130BA388.11

22-82 Work Point Calculation	
Option:	Function:
	<p>Example 1</p> <p>Illustration 3.57 Speed at System Design Working Point is Known</p> <p>From the datasheet showing characteristics for the specific equipment at different speeds, simply reading across from the H_{DESIGN} point and the Q_{DESIGN} point allows finding point A, which is the system design working point. The pump characteristics at this point should be identified and the associated speed programmed. Closing the valves and adjusting the speed until H_{MIN} has been achieved allows the speed at the no-flow point to be identified.</p> <p>Adjustment of <i>parameter 22-81 Square-linear Curve Approximation</i> then allows the shape of the control curve to be adjusted infinitely.</p> <p>Example 2</p> <p>Speed at system design working point is not known: Where the speed at system design working point is unknown, another reference point on the control curve needs to be determined based on the datasheet. By looking at the curve for the rated speed and plotting the design pressure (H_{DESIGN}, Point C), the flow at that pressure, Q_{RATED}, can be determined. Similarly, by plotting the design flow (Q_{DESIGN}, Point D), the pressure H_{DESIGN} at that flow can be determined. Knowing these 2 points on the pump curve, along</p>

22-82 Work Point Calculation	
Option:	Function:
	<p>with H_{MIN} as described above, allows the frequency converter to calculate the reference point B and thus to plot the control curve, which also includes the system design working point A.</p> <p>Illustration 3.58 Speed at System Design Working Point is not Known</p> <p>[0] Disabled Work point calculation not active. To be used if speed at design point is known.</p> <p>[1] Enabled Work point calculation is active. Enabling this parameter allows the calculation of the unknown system design working point at 50/60 Hz speed, from the input data set in:</p> <ul style="list-style-type: none"> • <i>Parameter 22-83 Speed at No-Flow [RPM].</i> • <i>Parameter 22-84 Speed at No-Flow [Hz].</i> • <i>Parameter 22-87 Pressure at No-Flow Speed.</i> • <i>Parameter 22-88 Pressure at Rated Speed.</i> • <i>Parameter 22-89 Flow at Design Point.</i> • <i>Parameter 22-90 Flow at Rated Speed.</i>

22-83 Speed at No-Flow [RPM]	
Range:	Function:
Size related*	<p>[0 - par. 22-85 RPM]</p> <p>Resolution 1 RPM.</p> <p>Enter the speed of the motor in RPM at which flow is 0 and minimum pressure H_{MIN} is achieved. Alternatively, enter the speed in Hz in <i>parameter 22-84 Speed at No-Flow [Hz]</i>. If <i>parameter 0-02 Motor Speed Unit</i> is set to RPM, <i>parameter 22-85 Speed at Design Point [RPM]</i> should also be used. Closing the valves and reducing the speed until minimum pressure H_{MIN} is achieved determines this value.</p>

22-84 Speed at No-Flow [Hz]		
Range:		Function:
Size related*	[0 - par. 22-86 Hz]	Resolution 0.033 Hz. Enter the motor speed in Hz at which flow has effectively stopped and minimum pressure H_{MIN} is achieved. Alternatively, enter the speed in RPM in <i>parameter 22-83 Speed at No-Flow [RPM]</i> . If <i>parameter 0-02 Motor Speed Unit</i> is set to Hz, <i>parameter 22-86 Speed at Design Point [Hz]</i> should also be used. Closing the valves and reducing the speed until minimum pressure H_{MIN} is achieved determines this value.

22-85 Speed at Design Point [RPM]		
Range:		Function:
Size related*	[par. 22-83 - 60000 RPM]	Resolution 1 RPM. Only visible when <i>parameter 22-82 Work Point Calculation</i> is set to [0] Disabled. Enter the motor speed in RPM at which the system design working point is achieved. Alternatively, enter the speed in Hz in <i>parameter 22-86 Speed at Design Point [Hz]</i> . If <i>parameter 0-02 Motor Speed Unit</i> is set to RPM, <i>parameter 22-83 Speed at No-Flow [RPM]</i> should also be used.

22-86 Speed at Design Point [Hz]		
Range:		Function:
Size related*	[par. 22-84 - par. 4-19 Hz]	Resolution 0.033 Hz. Only visible when <i>parameter 22-82 Work Point Calculation</i> is set to [0] Disabled. Enter the motor speed in Hz at which the system design working point is achieved. Alternatively, enter the speed in RPM in <i>parameter 22-85 Speed at Design Point [RPM]</i> . If <i>parameter 0-02 Motor Speed Unit</i> is set to Hz, <i>parameter 22-83 Speed at No-Flow [RPM]</i> should also be used.

22-87 Pressure at No-Flow Speed		
Range:		Function:
0*	[0 - par. 22-88]	Enter the pressure H_{MIN} corresponding to speed at no-flow in reference/feedback units.

22-88 Pressure at Rated Speed		
Also see <i>parameter 22-82 Work Point Calculation</i> .		
Range:		Function:
999999*	[par. 22-87 - 999999.999]	Enter the value corresponding to the pressure at rated speed, in reference/feedback units. This

22-88 Pressure at Rated Speed		
Also see <i>parameter 22-82 Work Point Calculation</i> .		
Range:		Function:
		value can be defined using the pump datasheet.

22-89 Flow at Design Point		
Also see <i>parameter 22-82 Work Point Calculation</i> .		
Range:		Function:
0*	[0 - 999999.999]	Enter the value corresponding to the flow at design point. No units necessary.

22-90 Flow at Rated Speed		
Also, see <i>parameter 22-82 Work Point Calculation</i> .		
Range:		Function:
0*	[0 - 999999.999]	Enter the value corresponding to flow at rated speed. This value can be defined using the pump datasheet.

3.19 Parameters: 23-** Time-based Functions

3.19.1 23-0* Timed Actions

Use timed actions for actions performed on a daily or weekly basis, for example different references for working hours/non-working hours. Up to 10 timed actions can be programmed in the frequency converter. Select the timed action number from the list when entering *parameter group 23-** Time-based Functions* from the LCP.

Parameter 23-00 ON Time and *parameter 23-04 Occurrence* then refer to the selected timed action number. Each timed action is divided into an ON time and an OFF time, in which 2 different actions may be performed.

Display lines 2 and 3 in the LCP show the status for timed actions mode (*parameter 0-23 Display Line 2 Large* and *parameter 0-24 Display Line 3 Large*, setting [1643] *Timed Actions Status*).

NOTICE

If commands are applied simultaneously to the digital inputs for constant OFF and constant ON, the timed actions mode changes to timed actions auto and the 2 commands are disregarded.

If *parameter 0-70 Set Date and Time* is not set or the frequency converter is set to hand-on mode or OFF mode (for example via the LCP), the timed actions mode is changed to [0] Disabled.

The timed actions have a higher priority than the same actions/commands activated by the digital inputs or the smart logic controller.

The actions programmed in timed actions are merged with corresponding actions from digital inputs, control word via bus, and smart logic controller, according to merge rules set up in *parameter group 8-5* Digital/Bus*.

NOTICE

Program the clock (*parameter group 0-7* Clock Settings*) correctly for timed actions to function.

NOTICE

When mounting VLT® Analog I/O Option MCB 109, a battery back-up of the date and time is included.

NOTICE

The PC-based configuration tool MCT 10 Set-up Software comprises a special guide for easy programming of timed actions.

23-00 ON Time		
Array [10]		
Range:		Function:
Size related*	[0 - 0]	Sets the ON time for the timed action.
<p>NOTICE</p> <p>The frequency converter has no back-up of the clock function and the set date/time resets to default (2000-01-01 00:00) after a power-down unless a real-time clock-module with back-up is installed. In <i>parameter 0-79 Clock Fault</i>, it is possible to program a warning if the clock has not been set properly, for example after a power-down.</p>		

23-01 ON Action		
Array [10]		
Option:		Function:
		Select the action during ON time. See <i>parameter 13-52 SL Controller Action</i> for descriptions of the options.
[0] *	Disabled	
[1]	No action	
[2]	Select set-up 1	
[3]	Select set-up 2	
[4]	Select set-up 3	
[5]	Select set-up 4	
[10]	Select preset ref 0	
[11]	Select preset ref 1	
[12]	Select preset ref 2	
[13]	Select preset ref 3	
[14]	Select preset ref 4	
[15]	Select preset ref 5	
[16]	Select preset ref 6	
[17]	Select preset ref 7	
[18]	Select ramp 1	
[19]	Select ramp 2	
[22]	Run	
[23]	Run reverse	
[24]	Stop	
[26]	DC Brake	
[27]	Coast	
[28]	Freeze output	
[29]	Start timer 0	
[30]	Start timer 1	
[31]	Start timer 2	
[32]	Set digital out A low	
[33]	Set digital out B low	
[34]	Set digital out C low	
[35]	Set digital out D low	
[36]	Set digital out E low	

23-01 ON Action		
Array [10]		
Option:	Function:	
[37]	Set digital out F low	
[38]	Set digital out A high	
[39]	Set digital out B high	
[40]	Set digital out C high	
[41]	Set digital out D high	
[42]	Set digital out E high	
[43]	Set digital out F high	
[50]	Night Action	
[51]	Day Action	
[60]	Reset Counter A	
[61]	Reset Counter B	
[70]	Start Timer 3	
[71]	Start Timer 4	
[72]	Start Timer 5	
[73]	Start Timer 6	
[74]	Start Timer 7	

23-02 OFF Time		
Array [10]		
Range:	Function:	
Size related*	[0 - 0]	Sets the OFF time for the timed action.
		<p>NOTICE</p> <p>The frequency converter has no back-up of the clock function and the set date/time is reset to default (2000-01-01 00:00) after a power-down unless a real-time clock module with back-up is installed. In <i>parameter 0-79 Clock Fault</i>, it is possible to program a warning if the clock has not been set properly, for example after a power-down.</p>

23-03 OFF Action		
Array [10]		
Option:	Function:	
		Select the action during OFF time. See <i>parameter 13-52 SL Controller Action</i> for descriptions of the options.
[0] *	Disabled	
[1]	No action	
[2]	Select set-up 1	
[3]	Select set-up 2	
[4]	Select set-up 3	
[5]	Select set-up 4	
[10]	Select preset ref 0	
[11]	Select preset ref 1	
[12]	Select preset ref 2	
[13]	Select preset ref 3	

23-03 OFF Action		
Array [10]		
Option:	Function:	
[14]	Select preset ref 4	
[15]	Select preset ref 5	
[16]	Select preset ref 6	
[17]	Select preset ref 7	
[18]	Select ramp 1	
[19]	Select ramp 2	
[22]	Run	
[23]	Run reverse	
[24]	Stop	
[26]	DC Brake	
[27]	Coast	
[28]	Freeze output	
[29]	Start timer 0	
[30]	Start timer 1	
[31]	Start timer 2	
[32]	Set digital out A low	
[33]	Set digital out B low	
[34]	Set digital out C low	
[35]	Set digital out D low	
[36]	Set digital out E low	
[37]	Set digital out F low	
[38]	Set digital out A high	
[39]	Set digital out B high	
[40]	Set digital out C high	
[41]	Set digital out D high	
[42]	Set digital out E high	
[43]	Set digital out F high	
[50]	Night Action	
[51]	Day Action	
[60]	Reset Counter A	
[61]	Reset Counter B	
[70]	Start Timer 3	
[71]	Start Timer 4	
[72]	Start Timer 5	
[73]	Start Timer 6	
[74]	Start Timer 7	

23-04 Occurrence		
Array [10]		
Option:	Function:	
	Select which day(s) the timed action applies to. Specify working/non-working days in: <ul style="list-style-type: none"> • <i>Parameter 0-81 Working Days.</i> • <i>Parameter 0-82 Additional Working Days.</i> • <i>Parameter 0-83 Additional Non-Working Days.</i> 	
[0] *	All days	
[1]	Working days	

23-04 Occurrence		
Array [10]		
Option:	Function:	
[2]	Non-working days	
[3]	Monday	
[4]	Tuesday	
[5]	Wednesday	
[6]	Thursday	
[7]	Friday	
[8]	Saturday	
[9]	Sunday	

3

3.19.2 23-1* Maintenance

Wear and tear calls for periodic inspection and service of elements in the application, for example motor bearings, feedback sensors, seals, and filters. With preventive maintenance, the service intervals may be programmed into the frequency converter. The frequency converter gives a message when maintenance is required. 20 preventive maintenance events can be programmed into the frequency converter.

Specify the following for each event:

- Maintenance item (for example, motor bearings).
- Maintenance action (for example, replacement).
- Maintenance time base (for example, running hours, or a specific date and time).
- Maintenance time interval or the date and time of next maintenance.

NOTICE

To disable a preventive maintenance event, set the associated *parameter 23-12 Maintenance Time Base* to [0] Disabled.

Preventive maintenance can be programmed from the LCP, but use of the PC-based MCT 10 Set-up Software is recommended.

3

ID	Name	Setup 1	Setup 2	Setup 3	Setup 4
2310.0	Maintenance Item	Motor bearings	Motor bearings	Motor bearings	Motor bearings
2310.1	Maintenance Item	Motor bearings	Motor bearings	Motor bearings	Motor bearings
2310.2	Maintenance Item	Motor bearings	Motor bearings	Motor bearings	Motor bearings
2310.3	Maintenance Item	Motor bearings	Motor bearings	Motor bearings	Motor bearings
2310.4	Maintenance Item	Motor bearings	Motor bearings	Motor bearings	Motor bearings
2310.5	Maintenance Item	Motor bearings	Motor bearings	Motor bearings	Motor bearings
2310.6	Maintenance Item	Motor bearings	Motor bearings	Motor bearings	Motor bearings
2310.7	Maintenance Item	Motor bearings	Motor bearings	Motor bearings	Motor bearings
2310.8	Maintenance Item	Motor bearings	Motor bearings	Motor bearings	Motor bearings
2310.9	Maintenance Item	Motor bearings	Motor bearings	Motor bearings	Motor bearings
2310.10	Maintenance Item	Motor bearings	Motor bearings	Motor bearings	Motor bearings
2310.11	Maintenance Item	Motor bearings	Motor bearings	Motor bearings	Motor bearings
2310.12	Maintenance Item	Motor bearings	Motor bearings	Motor bearings	Motor bearings
2310.13	Maintenance Item	Motor bearings	Motor bearings	Motor bearings	Motor bearings
2310.14	Maintenance Item	Motor bearings	Motor bearings	Motor bearings	Motor bearings
2310.15	Maintenance Item	Motor bearings	Motor bearings	Motor bearings	Motor bearings
2310.16	Maintenance Item	Motor bearings	Motor bearings	Motor bearings	Motor bearings
2310.17	Maintenance Item	Motor bearings	Motor bearings	Motor bearings	Motor bearings
2310.18	Maintenance Item	Motor bearings	Motor bearings	Motor bearings	Motor bearings
2310.19	Maintenance Item	Motor bearings	Motor bearings	Motor bearings	Motor bearings
2311.0	Maintenance Action	Lubricate	Lubricate	Lubricates	Lubricate
2311.2	Maintenance Action	Lubricate	Lubricate	Lubricates	Lubricate
2311.3	Maintenance Action	Lubricate	Lubricate	Lubricates	Lubricate
2311.4	Maintenance Action	Lubricate	Lubricate	Lubricates	Lubricate
2311.5	Maintenance Action	Lubricate	Lubricate	Lubricates	Lubricate
2311.6	Maintenance Action	Lubricate	Lubricate	Lubricates	Lubricate

Illustration 3.59 MCT 10 Set-up Software

The LCP indicates (with a wrench icon and letter M) when it is time for a preventive maintenance action and can be programmed to be indicated on a digital output in *parameter group 5-3* Digital Outputs*. The preventive maintenance status is shown in *parameter 16-96 Maintenance Word*. A preventive maintenance indication can be reset from a digital input, the FC bus, or manually from the LCP through *parameter 23-15 Reset Maintenance Word*.

A maintenance log with the latest 10 loggings can be read from *parameter group 18-0* Maintenance Log* and via the alarm log key on the LCP after selecting maintenance log.

NOTICE

The preventive maintenance events are defined in a 20-element array. Hence, each preventive maintenance event must use the same array element index in *parameter 23-10 Maintenance Item* to *parameter 23-14 Maintenance Date and Time*.

23-10 Maintenance Item	
Array [20]	
Option:	Function:
	Array with 20 elements shown below the parameter number in the display. Press [OK] and step between elements with [←], [→], [▲], and [▼].
	Select the item to be associated with the preventive maintenance event.
[1] *	Motor bearings
[2]	Fan bearings
[3]	Pump bearings
[4]	Valve
[5]	Pressure transmitter
[6]	Flow transmitter
[7]	Temperature transm.

23-10 Maintenance Item	
Array [20]	
Option:	Function:
[8]	Pump seals
[9]	Fan belt
[10]	Filter
[11]	Drive cooling fan
[12]	System health check
[13]	Warranty
[20]	Maintenance Text 0
[21]	Maintenance Text 1
[22]	Maintenance Text 2
[23]	Maintenance Text 3
[24]	Maintenance Text 4
[25]	Maintenance Text 5

23-11 Maintenance Action		
Array [20]		
Option:	Function:	
	Select the action to be associated with the preventive maintenance event.	
[1] *	Lubricate	
[2]	Clean	
[3]	Replace	
[4]	Inspect/Check	
[5]	Overhaul	
[6]	Renew	
[7]	Check	
[20]	Maintenance Text 0	
[21]	Maintenance Text 1	
[22]	Maintenance Text 2	
[23]	Maintenance Text 3	
[24]	Maintenance Text 4	
[25]	Maintenance Text 5	

23-12 Maintenance Time Base		
Array [20]		
Option:	Function:	
	Select the time base to be associated with the preventive maintenance event.	
[0] *	Disabled	Disables the preventive maintenance event.
[1]	Running Hours	The number of hours the motor has run. Running hours are not reset at power-on. Specify the maintenance time interval in <i>parameter 23-13 Maintenance Time Interval</i> .
[2]	Operating Hours	The number of hours the frequency converter has run. Operating hours are not reset at power-on. Specify the maintenance time interval in <i>parameter 23-13 Maintenance Time Interval</i> .
[3]	Date & Time	Uses the internal clock. Specify the date and time of the next maintenance occurrence in <i>parameter 23-14 Maintenance Date and Time</i> .

23-13 Maintenance Time Interval		
Array [20]		
Range:	Function:	
1 h*	[1 - 2147483647 h]	Set the interval associated with the current preventive maintenance event. This parameter is only used if [1] <i>Running Hours</i> or [2] <i>Operating Hours</i> is selected in <i>parameter 23-12 Maintenance Time Base</i> . The timer is reset from <i>parameter 23-15 Reset Maintenance Word</i> .
Example		
A preventive maintenance event is set up Monday at 8:00. <i>Parameter 23-12 Maintenance Time Base</i> is [2] <i>Operating hours</i> and		

23-13 Maintenance Time Interval		
Array [20]		
Range:	Function:	
	<i>parameter 23-13 Maintenance Time Interval</i> is 7 x 24 hours=168 hours. Next maintenance event is indicated the following Monday at 8:00. If this maintenance event is not reset until Tuesday at 9:00, the next occurrence is the following Tuesday at 9:00.	

23-14 Maintenance Date and Time		
Array [20]		
Range:	Function:	
Size related*	[0 - 0]	Set the date and time for next maintenance occurrence if the preventive maintenance event is based on date/time. Date format depends on the setting in <i>parameter 0-71 Date Format</i> while the time format depends on the setting in <i>parameter 0-72 Time Format</i> .
NOTICE		
The frequency converter has no back-up of the clock function and the set date/time is reset to default (2000-01-01 00:00) after a power-down. In <i>parameter 0-79 Clock Fault</i> , it is possible to program a warning if the clock has not been set properly, for example after a power-down. Set the time at least 1 hour later than actual time.		
NOTICE		
When mounting a VLT® Analog I/O option MCB 109 option card, a battery back-up of the date and time is included.		

23-15 Reset Maintenance Word		
Option:	Function:	
	<p>NOTICE</p> <p>When messages are reset - maintenance item, action, and maintenance date/time are not canceled. Parameter 23-12 Maintenance Time Base is set to [0] Disabled.</p> <p>Set this parameter to [1] Do reset to reset the maintenance word in parameter 16-96 Maintenance Word and reset the message shown in the LCP. This parameter changes back to [0] Do not reset when pressing [OK].</p>	
[0] *	Do not reset	
[1]	Do reset	

23-16 Maintenance Text		
Array [6]		
Range:	Function:	
0*	[0 - 20]	6 individual texts (Maintenance Text 0...Maintenance Text 5) can be written for use in either parameter 23-10 Maintenance Item or parameter 23-11 Maintenance Action. The text is written according to the guidelines in parameter 0-37 Display Text 1.

3.19.3 23-5* Energy Log

The frequency converter is continuously accumulating the consumption of the motor controlled, based on the actual power yielded by the frequency converter.

This data can be used for an energy log function allowing the user to compare and structure the information about the energy consumption related to time.

There are 2 functions:

- Data related to a pre-programmed period, defined by a set date and time for start.
- Data related to a predefined period back in time, for example last 7 days within the pre-programmed period.

For each of the above 2 functions, the data is stored in a number of counters allowing for selecting time frame and a split on hours, days, or weeks.

The period/split (resolution) can be set in parameter 23-50 Energy Log Resolution.

The data is based on the value registered by the kWh counter in the frequency converter. This counter value can

be read in parameter 15-02 kWh Counter containing the accumulated value since the first power-up or latest reset of the counter (parameter 15-06 Reset kWh Counter).

All data for the energy log is stored in counters, which can be read from parameter 23-53 Energy Log.

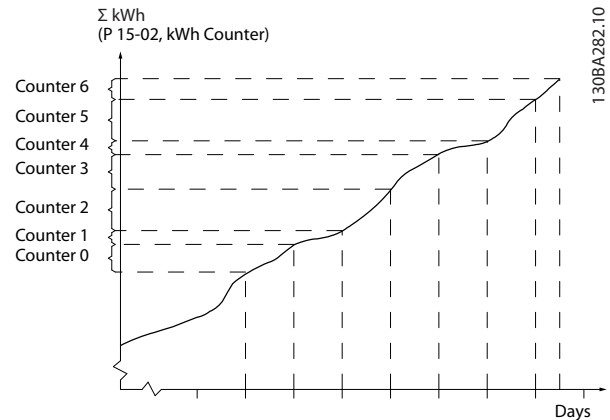

Illustration 3.60 Energy Log Graph

Counter 00 always contains the oldest data. A counter covers a period from XX:00 to XX:59 if hours or 00:00 to 23:59 if days.

If logging either the last hours or last days, the counters shift contents at XX:00 every hour or at 00:00 every day. The counter with highest index is always subject to update (containing data for the actual hour since XX:00 or the actual day since 00:00).

The contents of counters can be shown as bars on the LCP. Select Quick Menu, Loggings, Energy Log: Trending Continued Bin/Trending Timed Bin/Trending Comparison.

23-50 Energy Log Resolution		
Option:	Function:	
	<p>NOTICE</p> <p>The frequency converter has no back-up of the clock function and the set date/time resets to default (2000-01-01 00:00) after a power-down unless a real-time clock-module with back-up is installed. Consequently, the logging is stopped until date/time is readjusted in parameter 0-70 Set Date and Time. In parameter 0-79 Clock Fault it is possible to program a warning if the clock has not been set properly, for example after a power-down.</p> <p>Select the type of period for logging consumption: [0] Hour of Day, [1] Day of Week, or [2] Day of Month. The counters contain the logging data from the</p>	

23-50 Energy Log Resolution		
Option:	Function:	
		programmed date/time for start (<i>parameter 23-51 Period Start</i>) and the numbers of hours/days as programmed for (<i>parameter 23-50 Energy Log Resolution</i>). The logging starts on the date programmed in <i>parameter 23-51 Period Start</i> and continues until 1 day/week/month has passed. The counters contain data for 1 day, 1 week, or 5 weeks back in time, and up to the actual time. The logging starts at the date programmed in <i>parameter 23-51 Period Start</i> . In all cases, the period split refers to operating hours (time where frequency converter is powered up).
[0]	Hour of Day	
[1]	Day of Week	
[2]	Day of Month	
[5] *	Last 24 Hours	
[6]	Last 7 Days	
[7]	Last 5 Weeks	

23-51 Period Start		
Range:	Function:	
Size related* [0 - 0]	<p>NOTICE</p> <p>When mounting VLT® Analog I/O option MCB 109, a battery back-up of the date and time is included.</p> <p>Set the date and time at which the energy log starts updating the counters. First, data is stored in counter [00] and start at the time/date programmed in this parameter.</p> <p>Date format depends on setting in <i>parameter 0-71 Date Format</i> and time format on setting in <i>parameter 0-72 Time Format</i>.</p>	

23-53 Energy Log		
Array [31]		
Range:	Function:	
0* [0 - 4294967295]	<p>NOTICE</p> <p>All counters are automatically reset when changing the setting in <i>parameter 23-50 Energy Log Resolution</i>. At overflow, the update of the counters stops at maximum value.</p>	

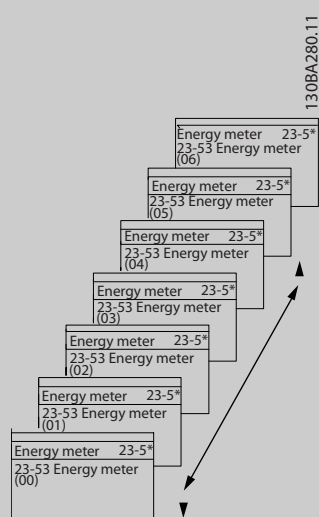
23-53 Energy Log		
Array [31]		
Range:	Function:	
	<p>NOTICE</p> <p>When mounting VLT® Analog I/O Option MCB 109 option card, a battery back-up of the date and time is included.</p> <p>Array with a number of elements equal to the number of counters ([00]-[xx] below parameter number in display). Press [OK] and step between elements with [▲] and [▼].</p> <p>Array elements:</p>  <p>Illustration 3.61 Energy Log</p> <p>Data from the latest period is stored in the counter with the highest index. At power-down, all counter values are stored and resumed at next power-up.</p>	

23-54 Reset Energy Log		
Option:	Function:	
	Select [1] Do reset to reset all values in the energy log-counters shown in <i>parameter 23-53 Energy Log</i> . After pressing OK, the setting of the parameter value automatically changes to [0] Do not reset.	
[0] *	Do not reset	
[1]	Do reset	

3.19.4 23-6* Trending

Trending is used to monitor a process variable over a period of time and record how often the data fall into each of 10 user-defined data ranges. This is a convenient tool to obtain a quick overview indicating where to focus on improvement of operation.

2 sets of data for trending can be created to make it possible to compare current values for a selected operating variable with data for a certain reference period, for the same variable. This reference period can be pre-programmed (*parameter 23-63 Timed Period Start* and *parameter 23-64 Timed Period Stop*). The 2 sets of data can be read from *parameter 23-61 Continuous Bin Data* (current) and *parameter 23-62 Timed Bin Data* (reference).

It is possible to create trending for following operation variables:

- Power.
- Current.
- Output frequency.
- Motor speed.

The trending function includes 10 counters (forming a bin) for each set of data containing the numbers of registrations reflecting how often the operating variable is within each of 10 pre-defined intervals. The sorting is based on a relative value of the variable.

The relative value for the operating variable is determined as:

- Actual/rated x 100% - for power and current.
- Actual/max x 100% - for output frequency and motor speed.

The size of each interval can be adjusted individually, but is 10% for each as default. Power and current can exceed rated value, but those registrations are included in 90–100% (MAX) counter.

equal 13%, the counter 10 to <20% is updated with the value 1. If the value stays at 13% for 10 s, 10 is added to the counter value.

The contents of counters can be shown as bars on the LCP. Select *Quick Menu*⇒*Loggings: Trending Continued Bin/Trending Timed Bin/Trending Comparison*.

NOTICE

The counters start counting whenever the frequency converter is powered up. Power cycle shortly after a reset zeros the counters. EEPROM data are updated once per hour.

23-60 Trend Variable		
Option:	Function:	
		Select the required operating variable to be monitored for trending.
[0] *	Power [kW]	Power yielded to the motor. Reference for the relative value is the rated motor power programmed in <i>parameter 1-20 Motor Power [kW]</i> or <i>parameter 1-21 Motor Power [HP]</i> . The actual value can be read in <i>parameter 16-10 Power [kW]</i> or <i>parameter 16-11 Power [hp]</i> .
[1]	Current [A]	Output current to the motor. Reference for the relative value is the rated motor current programmed in <i>parameter 1-24 Motor Current</i> . The actual value can be read in <i>parameter 16-14 Motor current</i> .
[2]	Frequency [Hz]	Output frequency to the motor. Reference for the relative value is the maximum output frequency programmed in <i>parameter 4-14 Motor Speed High Limit [Hz]</i> . The actual value can be read in <i>parameter 16-13 Frequency</i> .
[3]	Motor Speed [RPM]	Reference for the relative value is the maximum motor speed programmed in <i>parameter 4-13 Motor Speed High Limit [RPM]</i> .

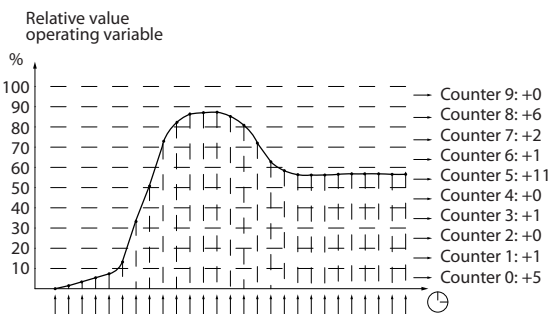

Illustration 3.62 Time and Relative Values

Once a second, the value of the operating variable selected is registered. If a value has been registered to

23-61 Continuous Bin Data	
Range:	Function:
0* [0 - 4294967295]	<p>Array with 10 elements ([0]-[9] below parameter number in display). Press [OK] and step between elements with [▲] and [▼].</p> <p>10 counters with the frequency of occurrence for the operating variable monitored, sorted according to the following intervals:</p> <ul style="list-style-type: none"> • Counter [0]: 0-<10%. • Counter [1]: 10-<20%. • Counter [2]: 20-<30%. • Counter [3]: 30-<40%. • Counter [4]: 40-<50%. • Counter [5]: 50-<60%. • Counter [6]: 60-<70%. • Counter [7]: 70-<80%. • Counter [8]: 80-<90%. • Counter [9]: 90-<100% or max. <p>The above minimum limits for the intervals are the default limits. These can be changed in <i>parameter 23-65 Minimum Bin Value</i>.</p> <p>Starts to count when the frequency converter is powered up for the first time. All counters can be reset to 0 in <i>parameter 23-66 Reset Continuous Bin Data</i>.</p>

23-62 Timed Bin Data	
Range:	Function:
0* [0 - 4294967295]	<p>Array with 10 elements ([0]-[9] below parameter number in display). Press [OK] and step between elements with [▲] and [▼].</p> <p>10 counters with the frequency of occurrence for the operating data monitored sorted according to the intervals as for <i>parameter 23-61 Continuous Bin Data</i>.</p> <p>Starts to count at the date/time programmed in <i>parameter 23-63 Timed Period Start</i>, and stops at the time/date programmed in <i>parameter 23-64 Timed Period Stop</i>. All counters can be reset to 0 in <i>parameter 23-67 Reset Timed Bin Data</i>.</p>

23-63 Timed Period Start	
Range:	Function:
Size related* [0 - 0]	<p>NOTICE</p> <p>The frequency converter has no back-up of the clock function and the set date/time is reset to default (2000-01-01 00:00) after a power-down unless a real-time clock-module with back-up is installed. Consequently, the logging is stopped until date/time is readjusted in <i>parameter 0-70 Set Date and Time</i>. In <i>parameter 0-79 Clock Fault</i> it is possible to program a warning if in case the clock has not been set properly, for example after a power-down.</p> <p>NOTICE</p> <p>When mounting VLT® Analog I/O option MCB 109, a battery back-up of the date and time is included.</p> <p>Set the date and time at which the trending starts the update of the timed bin counters.</p> <p>Date format depends on setting in <i>parameter 0-71 Date Format</i>, and time format on setting in <i>parameter 0-72 Time Format</i>.</p>

23-64 Timed Period Stop	
Range:	Function:
Size related* [0 - 0]	<p>NOTICE</p> <p>When mounting VLT® Analog I/O Option MCB 109, a battery back-up of the date and time is included.</p> <p>Set the date and time at which the trend analyses must stop updating the timed bin counters.</p> <p>Date format depends on the setting in <i>parameter 0-71 Date Format</i>, and time format on the setting in <i>parameter 0-72 Time Format</i>.</p>

23-65 Minimum Bin Value		
Range:	Function:	
Size related* [0 - 100 %]	Array with 10 elements ([0]–[9] below parameter number in display). Press [OK] and step between elements with [▲] and [▼]. Set the minimum limit for each interval in <i>parameter 23-61 Continuous Bin Data</i> and <i>parameter 23-62 Timed Bin Data</i> . Example: If selecting [1] counter and changing setting from 10% to 12%, [0] counter is based on the interval 0 to <12% and [1] counter on interval 12 to <20%.	

23-66 Reset Continuous Bin Data		
Option:	Function:	
[0] *	Do not reset	Select [1] Do reset to reset all values in <i>parameter 23-61 Continuous Bin Data</i> . After pressing [OK], the setting of the parameter value automatically changes to [0] Do not reset.

23-66 Reset Continuous Bin Data		
Option:	Function:	
[1]	Do reset	

23-67 Reset Timed Bin Data		
Option:	Function:	
		Select [1] Do reset to reset all counters in <i>parameter 23-62 Timed Bin Data</i> . After pressing [OK], the setting of the parameter value automatically changes to [0] Do not reset.
[0] *	Do not reset	
[1]	Do reset	

3.19.5 23-8* Payback Counter

The frequency converter includes a feature which can give a rough calculation on payback in cases where the frequency converter has been installed in an existing plant to ensure energy savings. Reference for the savings is a set value to represent the average power yielded before the upgrade with variable speed control.

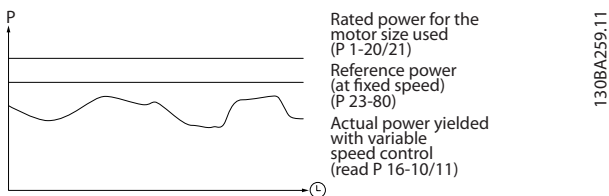

Illustration 3.63 Variable Speed Control

The difference between the reference power at fixed speed and the actual power yielded with speed control represent the actual saving.

As value for the fixed speed case, the rated motor size (kW) is multiplied with a factor (set in %) representing the power produced at fixed speed. The difference between this reference power and the actual power is accumulated and stored. The difference in energy can be read in *parameter 23-83 Energy Savings*.

The accumulated value for the difference in power consumption is multiplied with the energy cost in local currency and the investment is subtracted. This calculation for cost savings can also be read in *parameter 23-84 Cost Savings*.

$$\begin{aligned}
 \text{Cost Savings} = & \left\{ \sum_{t=0}^t \left[(\text{Rated Motor Power} * \text{Power Reference Factor}) \right. \right. \\
 & \left. \left. - \text{Actual Power Consumption} \right] * \text{Energy Cost} \right\} \\
 & - \text{Investment Cost}
 \end{aligned}$$

Breakeven (payback) occurs when the value read in the parameter turns from negative to positive.

It is not possible to reset the energy savings counter, but the counter can be stopped any time by setting *parameter 23-80 Power Reference Factor* to 0.

Parameter for settings		Parameters for readout	
Rated motor power	<i>Parameter 1-20 Motor Power [kW]</i>	Energy savings	<i>Parameter 23-83 Energy Savings</i>
Power reference factor in %	<i>Parameter 23-80 Power Reference Factor</i>	Actual power	<i>Parameter 16-10 Power [kW], parameter 16-11 Power [hp]</i>
Energy cost per kWh	<i>Parameter 23-81 Energy Cost</i>	Cost savings	<i>Parameter 23-84 Cost Savings</i>
Investment	<i>Parameter 23-82 Investment</i>		

Table 3.22 Parameter Overview

23-80 Power Reference Factor		
Range:	Function:	
100 % *	[0 - 100 %]	Set the percentage of the rated motor size (set in <i>parameter 1-20 Motor Power [kW]</i> or <i>parameter 1-21 Motor Power [HP]</i>), which shows the average power yielded at the time running with fixed speed (before upgrade with variable speed control). Set a value different from 0 to start counting.

23-81 Energy Cost		
Range:	Function:	
1*	[0 - 999999.99]	Set the actual cost for a kWh in local currency. If the energy cost is changed later on, it impacts the calculation for the entire period.

23-82 Investment		
Range:	Function:	
0*	[0 - 999999999]	Set the value of the investment spent on upgrading the plant with speed control, in same currency as used in <i>parameter 23-81 Energy Cost</i> .

23-83 Energy Savings		
Range:	Function:	
0 kWh*	[0 - 0 kWh]	This parameter allows a readout of the accumulated difference between the reference power and the actual output power. If motor size is set in hp (<i>parameter 1-21 Motor Power [HP]</i>), the equivalent kW value is used for the energy savings.

23-84 Cost Savings		
Range:	Function:	
0*	[0 - 2147483647]	This parameter allows a readout of the calculation based on the above equation (in local currency).

3.20 Parameters: 25-**-** Pack Controller

3.20.1 25-**-** Pack Controller

Parameters for configuring the basic pack controller for sequence control of multiple compressors. For a more application-oriented description and wiring examples, see *Application Examples, Basic Pack Controller* in the *design guide*.

3

To configure the pack controller to the actual system and the desired control strategy, follow the sequence, starting with *parameter group 25-0* System Settings* and next *parameter group 25-5* Alternation Settings*. These parameters can normally be set in advance.

Parameters in parameter groups *25-2* Zone Settings*, *25-3* Staging Functions*, and *25-4* Staging settings* often depend on the dynamic of the system and final adjustments to be done at the commissioning of the plant.

Usually, only parameter groups *25-0* System Settings* and *25-2* Zone Settings* need adjustment.

NOTICE

The pack controller is supposed to operate in closed loop controlled by the built-in PI controller ([3] *Process Closed Loop* selected in *parameter 1-00 Configuration Mode*). If [0] *Speed Open Loop* is selected in *parameter 1-00 Configuration Mode*, all fixed speed compressors are destaged, but the variable speed compressor is still controlled by the frequency converter, now as an open-loop configuration:

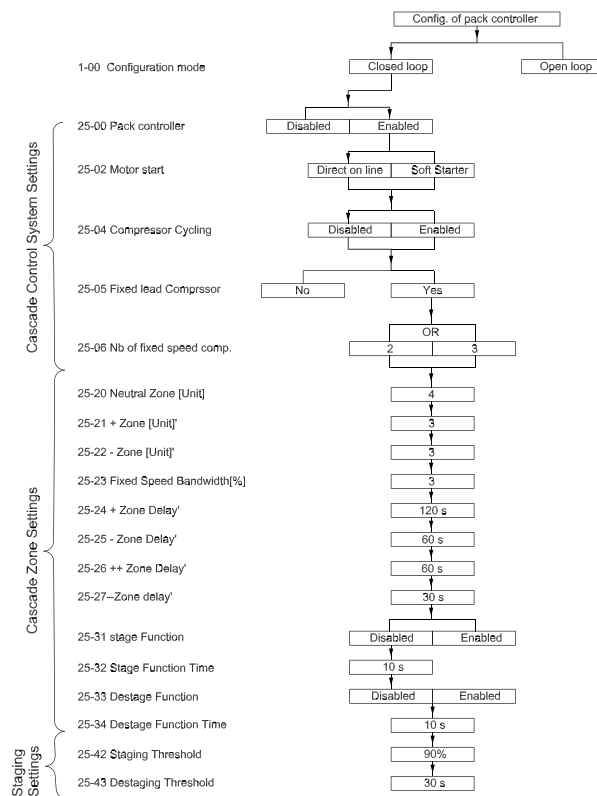

Illustration 3.64 Pack Controller Sample Set-up

3.20.2 25-0* System Settings

Parameters related to control principles and configuration of the system.

25-00 Pack Controller		
Option:	Function:	
		For operation of multiple device systems where capacity is adapted to actual load with speed control combined with on/off control of the devices. For simplicity, only compressor systems are described.
[0] *	Disabled	The pack controller is not active. All built-in relays assigned to compressor motors in the pack function are de-energized. If a variable speed compressor is connected to the frequency converter directly (not controlled by a built-in relay), this compressor is controlled as a single-compressor system.
[1]	Enabled	The pack controller is active and stages/destages compressors according to load on the system.

NOTICE

This parameter can only be [1] Enabled, if parameter 22-75 Short Cycle Protection is set to [0] Disabled.

25-02 Motor Start		
Option:	Function:	
		Motors are connected to mains directly with a contactor or with a soft starter. When the value of parameter 25-02 Motor Start is set to an option other than [0] Direct on Line, then parameter 25-50 Lead Pump Alternation is automatically set to the default of [0] Direct on Line.
[0] *	Direct on Line	Each fixed speed pump is connected to mains directly via a contactor.
[1]	Soft Starter	Each fixed speed pump is connected to mains via a soft starter.
[2]	Star-Delta	Fixed pumps connected with star-delta starters are staged in the same way as pumps connected with soft starters. They are destaged in the same way as pumps connected directly to mains.

25-04 Pump Cycling		
Option:	Function:	
		To provide equal hours of operation with fixed speed compressors, the compressor used can be cycled. The selection of compressor cycling is either first in – last out or equal running hours for each compressor.
[0] *	Disabled	The fixed speed compressors are connected in the order 1–2 and disconnected in the order 2–1 (first in–last out).

25-04 Pump Cycling		
Option:	Function:	
[1]	Enabled	The fixed speed compressors are connected/disconnected to have equal running hours for each compressor.

25-05 Fixed Lead Compressor		
Option:	Function:	
		Fixed lead compressor is a configuration when the variable speed compressor is connected directly to the frequency converter, and if a contactor is applied between frequency converter and compressor, this contactor is not controlled by the frequency converter. If operating with parameter 25-50 Lead Pump Alternation set to other than [0] Off, set this parameter to [0] No.
[0]	No	The lead compressor function can alternate between the compressors controlled by the 2 built-in relays. Connect 1 compressor to the built-in relay 1, and the other compressor to relay 2. The compressor function (pack compressor1 and pack compressor2) is automatically assigned to the relays (maximum 2 compressors can in this case be controlled by the frequency converter).
[1] *	Yes	The lead compressor is fixed (no alternation) and connected directly to the frequency converter. The parameter 25-50 Lead Pump Alternation is automatically set to [0] Off. Built-in relays relay 1 and relay 2 can be assigned to separate fixed speed compressors. In total, 3 compressors can be controlled by the frequency converter.

25-06 Number of Compressors		
Range:	Function:	
		The number of compressors connected to the pack controller including the variable speed compressor. If the variable speed compressor is connected directly to the frequency converter and the other fixed speed compressors (lag compressors) are controlled by the 2 built-in relays, 3 compressors can be controlled. If both the variable speed and fixed speed compressors are controlled by built-in relays, only 2 compressors can be connected.
2* - 6]	[2 - 6]	If parameter 25-06 Number of Compressors is set to 2 compressors, the set-up is: 1 variable speed compressor and 1 fixed speed compressor, both controlled by built-in relay. If parameter 25-06 Number of Compressors is set to 3 compressors, the set-up is: 1 variable speed compressor and 2 fixed speed compressors, all controlled by the built-in relay. Up to 6 compressor can be controlled using the VLT® Extended Relay Card MCB 113.

3.20.3 25-2* Zone Settings

Parameters for setting the bandwidth within which the pressure is allowed to operate before staging/destaging fixed speed compressors. Also includes various timers to stabilize the control.

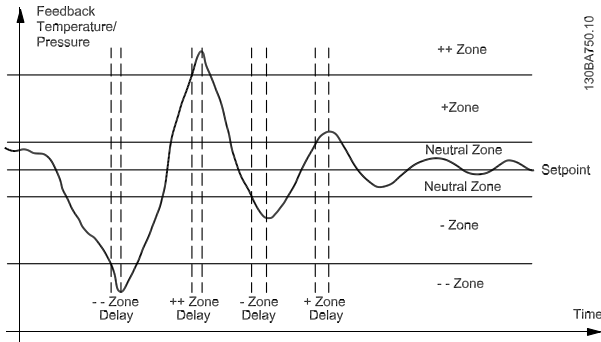

Illustration 3.65 Zone Settings

The fixed speed compressor(s) is staged/destaged if the actual feedback is 1 of the zones outside the neutral zone for more than the delay time set for this zone. If the actual feedback is in the ++zone or --zone, the compressor(s) is staged/destaged at the time the first delay timer runs out. The ++zone delay should always be shorter than the +zone delay to make it active.

25-20 Neutral Zone [unit]		
Range:	Function:	
4 Reference-FeedbackUnit*	[0 - 9999.99 ReferenceFeed-backUnit]	Set the neutral zone (NZ) to accommodate normal system pressure fluctuations. In pack control systems, to avoid frequent switching of fixed speed compressors, the reference system pressure is typically kept within a zone rather than at a constant level. The unit of the neutral zone is the same as selected in <i>parameter 20-12 Reference/Feedback Unit</i> . The neutral zone is defined in the following way: If the setpoint is -20 °C (4 °F) and the neutral zone is 4 °C (39 °F), a

25-20 Neutral Zone [unit]		
Range:	Function:	
		suction pressure equivalent to a temperature -24 °C to -16 °C (-11 °F to 3 °F) is tolerated. No staging or destaging occurs within this zone.

25-21 + Zone [unit]		
Range:	Function:	
3 ReferenceFeed-backUnit*	[0 - 9999.99 ReferenceFeed-backUnit]	When a large and quick change in the system demand occurs, the system pressure rapidly changes and a quicker staging or destaging of a fixed speed compressor is necessary. The +zone defines the range where the +zone delay is active. Do not set the +zone value too close to 0 to avoid frequent stagings at momentary pressure changes. See <i>parameter 25-26 ++ Zone Delay</i> . To avoid unintended staging during the commissioning and fine-tuning of the controller, start with the +zone value beyond any expected pressure peak. This implicitly disables the override function for pressure peaks. When the fine-tuning is complete, set the +zone value to the required value. For example, use 3 °C (37 °F) as the initial value.

25-22 - Zone [unit]		
Range:	Function:	
3 ReferenceFeed-backUnit*	[0 - 9999.99 ReferenceFeed-backUnit]	When a large and quick change in the system demand occurs, the system pressure rapidly changes and a quicker staging or destaging of a fixed speed compressor is necessary. The -zone defines the range where the -zone delay is active.

25-22 - Zone [unit]		
Range:		Function:
		<p>Do not set the -zone value too close to 0 to avoid frequent stagings at momentary pressure changes. See <i>parameter 25-27 -- Zone Delay</i>.</p> <p>To avoid unintended staging during the commissioning and fine-tuning of the controller, start with the -zone value beyond any expected pressure drop. This implicitly disables the override function for pressure drops. When the fine-tuning is complete, set the -zone value to the required value. For example, use 3 °C as the initial value.</p>

25-23 Fixed Speed neutral Zone [unit]		
Range:		Function:
4 ReferenceFeed-backUnit*	[0 - 9999.99 ReferenceFeed-backUnit]	<p>When the pack control system is running normally and the frequency converter issues a trip alarm, it is important to maintain the system head. The pack controller does this by continuing to stage/destage fixed speed compressors on and off. When only a fixed speed compressor runs, keeping the head at the setpoint requires frequent staging and destaging. To avoid frequent staging and destaging, the frequency converter uses a wider fixed speed bandwidth (FSBW) instead of SBW. If an alarm occurs, stop the fixed speed compressors by pressing [Off], or [Hand On], or set the signal programmed for start on a digital input to low.</p> <p>If the issued alarm is a trip lock alarm then the pack controller stops the system</p>

25-23 Fixed Speed neutral Zone [unit]		
Range:		Function:
		<p>immediately by cutting out all the fixed speed compressors. This is the same as emergency stop (coast/coast inverse command) for the pack controller.</p>

25-24 + Zone Delay		
Range:		Function:
120 s*	[0 - 3000 s]	<p>When the pressure in the system exceeds the neutral zone value for a moment, immediate staging of a fixed speed compressor may cause damage to equipment. The +zone delay delays the staging of a fixed speed compressor. If the pressure gets within the neutral zone before the timer has elapsed, the timer is reset and no staging occurs.</p>

25-25 - Zone Delay		
Range:		Function:
60 s*	[0 - 3000 s]	<p>When the pressure in the system drops below the neutral zone value for a moment, immediate destaging of a fixed speed compressor may cause damage to equipment. The -zone delay delays the destaging of a fixed speed compressor. If the pressure gets within the neutral zone before the timer has elapsed, the timer is reset and no destaging occurs.</p>

25-26 ++ Zone Delay		
Range:		Function:
60 s*	[0 - 300 s]	<p>Staging a fixed speed compressor creates a momentary pressure peak in the system, and the pressure may exceed the sum of the neutral zone value and the +zone value. If the pressure peak is short, the frequency converter should not destage a compressor. The ++zone delay prevents staging until the system pressure is stabilized and normal control is established. Set the delay to a value that allows the system to stabilize after staging.</p> <p>Since +zone delay may be too long to react to a high-pressure peak, the ++zone delay should be shorter than the +zone delay. The 60 s factory setting is appropriate in most applications. In highly dynamic systems, use a shorter time.</p>

25-27 -- Zone Delay		
Range:	Function:	
30 s*	[0 - 300 s]	Destaging a fixed speed compressor creates a momentary pressure drop in the system, and the pressure may exceed the sum of the neutral zone value and the -zone value. If the pressure drop is short, the frequency converter should not destage a compressor. The --zone delay prevents destaging until the system pressure is stabilized and normal control is established. Set the delay to a value that allows the system to stabilize after destaging. Since -zone delay may be too long to react to a high-pressure drop, the --zone delay should be shorter than the -zone delay. The 60 s factory setting is appropriate in most applications. In highly dynamic systems, use a shorter time.

25-28 Override Bandwidth Ramp Time		
Enter the override bandwidth ramp time.		
Range:	Function:	
Size related*	[0.0 - 3600 s]	

3.20.4 25-3* Staging Functions

Parameters for setting the staging and destaging functions and avoiding frequent staging and destaging of fixed speed compressors.

25-30 Destage At No-Flow		
Enable or disable the destage at no-flow function. When enabled, the frequency converter destages fixed speed compressors 1 at a time when there is a no-flow condition.		
Option:	Function:	
[0] *	Disabled	
[1]	Enabled	

25-31 Stage Function		
Enable or disable the stage function.		
Option:	Function:	
[0] *	Disabled	
[1]	Enabled	

25-32 Stage Function Time		
Range:	Function:	
15 s*	[0 - 300 s]	The stage function time is programmed to avoid frequent staging of the fixed speed pumps. The stage function time starts if it is [1] Enabled by parameter 25-31 Stage Function, and when the variable speed pump runs at motor speed high limit, parameter 4-13 Motor Speed High Limit [RPM] or parameter 4-14 Motor Speed High Limit [Hz], with at least 1 fixed speed pump in the stop position. When the programmed value of the timer expires, a fixed speed pump is staged.

25-33 Destage Function		
Option:	Function:	
		The destage function ensures that the minimum number of compressors is running to save energy. If the destage function is set to [0] Disabled, parameter 25-34 Destage Function Time is not be activated.
[0] *	Disabled	
[1]	Enabled	

25-34 Destage Function Time		
Range:	Function:	
15 s*	[0 - 300 s]	The destage function timer is programmable to avoid frequent staging/destaging of the fixed speed pumps. The destage function time starts when the adjustable speed pump is running at parameter 4-11 Motor Speed Low Limit [RPM] or parameter 4-12 Motor Speed Low Limit [Hz], with 1 or more fixed speed pumps in operation and system requirements satisfied. In this situation, the adjustable speed pump contributes a little to the system. When the programmed value of the timer expires, a stage is removed, avoiding dead head water circulation in the adjustable speed pump.

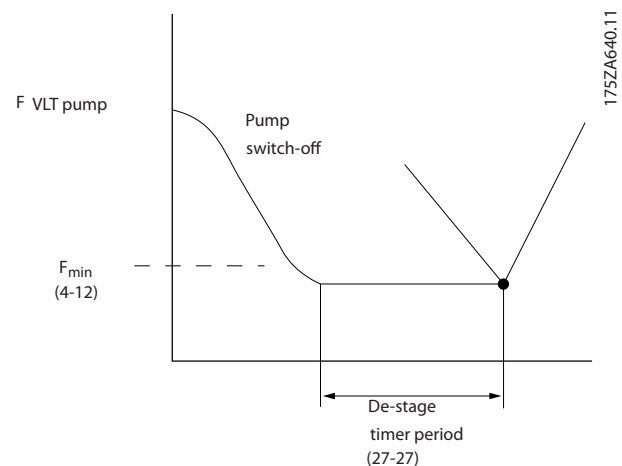

Illustration 3.66 Destage Function Time

3.20.5 25-4* Staging Settings

Parameters determining conditions for staging/destaging the compressors.

25-42 Staging Threshold

To prevent an overshoot of pressure, the variable speed compressor ramps down to a lower speed when adding a fixed speed compressor. When the variable speed compressor reaches the staging speed, the fixed speed compressor is staged. The frequency converter calculates the speed of the variable speed compressor when the cut-in point of the fixed speed compressor occurs using the staging threshold. The staging threshold is the ratio of *parameter 4-11 Motor Speed Low Limit [RPM]* or *parameter 4-12 Motor Speed Low Limit [Hz]* to *parameter 4-13 Motor Speed High Limit [RPM]* or *parameter 4-14 Motor Speed High Limit [Hz]* expressed in percent. Staging threshold ranges from:

$$\eta_{STAGE\%} = \frac{\eta_{LOW}}{\eta_{HIGH}} \times 100\%$$

to 100%, where n_{LOW} is the motor speed low limit, and n_{HIGH} is the motor speed high limit.

130BA733.10

Range:

Function:

Size related*	[0 - 100 %]	
---------------	--------------	--

25-43 Destaging Threshold

To prevent an undershoot of pressure, the variable speed compressor ramps up to a higher speed before removing a fixed speed compressor. When the variable speed compressor reaches the destaging speed, the fixed speed compressor is destaged. The frequency converter calculates the speed of the variable speed compressor when the destaging of the fixed speed compressor occurs using the destaging threshold. The destaging threshold is the ratio of *parameter 4-11 Motor Speed Low Limit [RPM]* or *parameter 4-12 Motor Speed Low Limit [Hz]* to *parameter 4-13 Motor Speed High Limit [RPM]* or *parameter 4-14 Motor Speed High Limit [Hz]* expressed in percent. Destaging threshold ranges from:

$$\eta_{STAGE\%} = \frac{\eta_{LOW}}{\eta_{HIGH}} \times 100\%$$

to 100%, where n_{LOW} is the motor speed low limit, and n_{HIGH} is the motor speed high limit.

130BA367.10

Range:

Function:

Size related*	[0 - 100 %]	
---------------	--------------	--

25-44 Staging Speed [RPM]

Readout of the calculated value for staging speed. When adding a fixed speed compressor to prevent an overshoot of pressure, the variable speed compressor ramps down to a lower speed. When the variable speed compressor reaches the staging speed, the fixed speed compressor is staged. Staging speed calculation is based on *parameter 25-42 Staging Threshold* and *parameter 4-13 Motor Speed High Limit [RPM]*. Staging speed is calculated with the following formula:

$$\eta_{STAGE} = \eta_{HIGH} \frac{\eta_{STAGE\%}}{100}$$

where n_{HIGH} is the motor speed high limit and $n_{STAGE100\%}$ is the value of staging threshold.

Range:

Function:

0 RPM*	[000 - 30000 RPM]	
--------	-------------------	--

25-45 Staging Speed [Hz]

Option:	Function:
0 N/A	Readout of the below calculated value for staging speed. When adding a fixed speed compressor to prevent an overshoot of pressure, the variable speed compressor ramps down to a lower speed. When the variable speed compressor reaches the staging speed, the fixed speed compressor is staged on. Staging speed calculation is based on <i>parameter 25-42 Staging Threshold</i> and <i>parameter 4-14 Motor Speed High Limit [Hz]</i> .

25-45 Staging Speed [Hz]

Option: Function:

	<p>Staging speed is calculated with the following formula:</p> $n_{STAGE} = n_{HIGH} \frac{n_{STAGE\%}}{100}$ <p>where n_{HIGH} is motor speed high limit and $n_{STAGE100\%}$ is the value of the staging threshold.</p>
--	---

25-46 Destaging Speed [RPM]

Readout of the below calculated value for destaging speed. When removing a fixed speed compressor to prevent an undershoot of pressure, the variable speed compressor ramps up to a higher speed. When the variable speed compressor reaches the destaging speed, the fixed speed compressor is destaged. Destaging speed is calculated based on *parameter 25-43 Destaging Threshold* and *parameter 4-13 Motor Speed High Limit [RPM]*.

Destaging speed is calculated with the following formula:

$$n_{DESTAGE} = n_{HIGH} \frac{n_{DESTAGE\%}}{100}$$

where n_{HIGH} is motor speed high limit and $n_{DESTAGE100\%}$ is the value of the destaging threshold.

Range: Function:

0 RPM*	[000 - 30000 RPM]
--------	-------------------

25-47 Destaging Speed [Hz]

Readout of the below calculated value for destaging speed. When removing a fixed speed compressor to prevent an undershoot of pressure, the variable speed compressor ramps up to a higher speed. When the variable speed compressor reaches the destaging speed, the fixed speed compressor is destaged. Destaging speed is calculated based on *parameter 25-43 Destaging Threshold* and *parameter 4-14 Motor Speed High Limit [Hz]*.

Destaging speed is calculated with the following formula:

$$n_{DESTAGE} = n_{HIGH} \frac{n_{DESTAGE\%}}{100}$$

where n_{HIGH} is motor speed high limit and $n_{DESTAGE100\%}$ is the value of the destaging threshold.

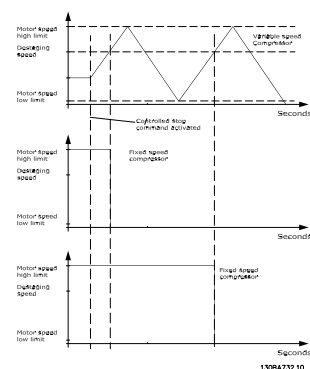

Illustration 3.67 Destaging Speed

Range: Function:

0 Hz*	[0 - 6500 Hz]
-------	---------------

3.20.6 25-5* Alternation Settings

Parameters for defining the conditions for alternation of the variable speed pump (lead), if selected as control strategy.

25-50 Lead Pump Alternation		
Option:	Function:	
		<p>NOTICE</p> <p>If <i>parameter 25-05 Fixed Lead Compressor</i> is set to [1] Yes, it is only possible to select [0] Off.</p> <p>Lead pump alternation equalizes the use of pumps by periodically changing the pump that is speed-controlled. This ensures that pumps are equally used over time. Alternation equalizes the usage of pumps by always selecting the pump with the lowest number of hours run to stage on next.</p>
[0]	Off	No alternation of lead pump function takes place. It is not possible to set this parameter to options other than [0] Off if <i>parameter 25-02 Motor Start</i> is set other than [0] Direct on Line.
[1]	At staging	Alternation of the lead pump function takes place when staging another pump.
[2]	At command	Alternation of the lead pump function takes place at an external command signal or a pre-programmed event. See <i>parameter 25-51 Alternation Event</i> for available options.
[3]	At staging or command	Alternation of the variable speed (lead) pump takes place at staging or according to [2] At command.

25-51 Alternation Event		
Option:	Function:	
		This parameter is only active if the options [2] <i>At Command</i> or [3] <i>At Staging or Command</i> have been selected in <i>parameter 25-50 Lead Pump Alternation</i> . If an alternation event is selected, the alternation of lead pump takes place every time the event occurs.
[0] *	External	Alternation takes place when a signal is applied to 1 of the digital inputs on the terminal strip and this input has been assigned to [121] <i>Lead Pump Alternation</i> in <i>parameter group 5-1*, Digital Inputs</i> .
[1]	Alternation Time Interval	Alternation takes place every time <i>parameter 25-52 Alternation Time Interval</i> expires.
[2]	Sleep Mode	Alternation takes place each time the lead pump goes into sleep mode. Set <i>parameter 20-23 Setpoint 3</i> to [1] <i>Sleep Mode</i> or apply an external signal for this function.
[3]	Predefined Time	Alternation takes place at a defined time of the day. If <i>parameter 25-54 Alternation Predefined Time</i> is set, the alternation is carried out every day at the specified time. Default time is midnight (00:00 or 12:00AM depending on the time format).

25-52 Alternation Time Interval		
Range:	Function:	
24 h*	[1 - 999 h]	If selecting [1] <i>Alternation Time Interval</i> in <i>parameter 25-51 Alternation Event</i> , the alternation of the variable speed pump takes place every time the alternation time interval expires (can be checked in <i>parameter 25-53 Alternation Timer Value</i>).

25-53 Alternation Timer Value		
Range:	Function:	
0*	[0 - 7]	Readout parameter for the alternation time interval value set in <i>parameter 25-52 Alternation Time Interval</i> .

25-54 Alternation Predefined Time		
Range:	Function:	
Size related*	[0 - 0]	If selecting [3] <i>Predefined Time</i> in <i>parameter 25-51 Alternation Event</i> , the variable speed pump alternation is carried out every day at the specified time set in alternation predefined time. Default time is midnight (00:00 or 12:00AM depending on the time format).

25-55 Alternate if Load < 50%		
Option:	Function:	
		<p>NOTICE</p> <p>Only valid if <i>parameter 25-50 Lead Pump Alternation</i> is different from [0] <i>Off</i>.</p> <p>If selecting [1] <i>Enabled</i>, the pump alternation can only occur if the capacity is equal to or below 50%. The capacity calculation is the ratio of running pumps (including the variable speed pump) to the total number of available pumps (including variable speed pump, but not those that are interlocked).</p> $Capacity = \frac{N_{RUNNING}}{N_{TOTAL}} \times 100\%$ <p>For the basic cascade controller, all pumps are of equal size.</p>
[0]	Disabled	The lead pump alternation takes place at any pump capacity.
[1] *	Enabled	The lead pump function is alternated only if the number of pumps running are providing less than 50% of total pump capacity.

25-56 Staging Mode at Alternation		
Option:	Function:	
		<p>This parameter is only active if the option selected in <i>parameter 25-50 Lead Pump Alternation</i> is different from [0] <i>Off</i>.</p> <p>2 types of staging and destaging of pumps are possible. Slow transfer makes staging and destaging smooth. Quick transfer makes staging and destaging as fast as possible; the variable speed pump is just cut out (coasted).</p>
[0] *	Slow	At alternation, the variable speed pump is ramped up to maximum speed and then ramped down to a standstill.
[1]	Quick	At alternation, the variable speed pump is ramped up to maximum speed and then coasted to standstill.

Illustration 3.67 is an example of the slow transfer-staging. The variable speed pump (top graph) and 1 fixed speed pump (bottom graph) run before the staging command. When the [0] *Slow* transfer command is activated, an alternation is carried out by ramping the variable speed pump to *parameter 4-13 Motor Speed High Limit [RPM]* or *parameter 4-14 Motor Speed High Limit [Hz]*, and then decelerated to zero speed. After a delay before starting next pump (*parameter 25-58 Run Next Pump Delay*), the next lead pump (middle graph) is accelerated and another original lead pump (top graph) is added after the delay before running on mains (*parameter 25-59 Run on Mains Delay*) as a fixed speed pump. The next lead pump (middle

graph) is decelerated to motor speed low limit and then allowed to vary speed to maintain system pressure.

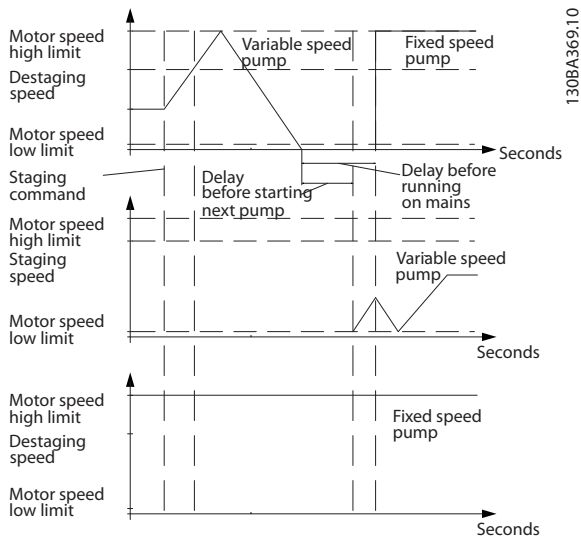

Illustration 3.67 Staging Mode at Alternation

130BA369.10

25-58 Run Next Pump Delay		
Range:	Function:	
0.1 s* [0.1 - 5 s]	This parameter is only active if the option selected in <i>parameter 25-50 Lead Pump Alternation</i> is different from [0] Off. This parameter sets the time between stopping the old variable speed pump and starting another pump as a new variable speed pump. Refer to <i>parameter 25-56 Staging Mode at Alternation</i> for description of staging and alternation.	

25-59 Run on Mains Delay		
Range:	Function:	
0.5 s* [par. 25-58 - 5 s]	This parameter is only active if the option selected in <i>parameter 25-50 Lead Pump Alternation</i> , is different from [0] Off. This parameter sets the time between stopping the old variable speed pump and starting this pump as a new fixed speed pump. Refer to <i>Illustration 3.67</i> for description of staging and alternation.	

3.20.7 25-8* Status

Readout parameters informing about the operating status of the pack controller and the compressors controlled.

25-80 Pack Status		
Readout of the status of the pack controller.		
Range:	Function:	
0*	[0 - 25]	

25-81 Compressor Status		
Range:	Function:	
0*	[0 - 25]	This parameter shows the status for the number of compressors selected in <i>parameter 25-06 Number of Compressors</i> . It is a readout of the status for each of the compressors showing a string, which consists of compressor number and the current status of the compressor. Example: Readout is 1:D 2:O. This means that compressor 1 is running, and the speed is controlled by the frequency converter, and compressor 2 is stopped.

25-82 Lead Compressor		
Range:	Function:	
0*	[0 - par. 25-06]	Readout parameter for the actual variable speed compressor in the system. The lead compressor parameter is updated to reflect the current variable speed compressor in the system when an alternation takes place. If no lead compressor is selected (pack controller disabled or all pumps interlocked), the display shows NONE.

25-83 Relay Status		
Array [2]		
Option:	Function:	
	Read out of the status for each of the relays assigned to control the compressors. Every element in the array represents a relay. If a relay is activated, the corresponding element is set to On. If a relay is deactivated, the corresponding element is set to Off.	
On		
Off		

25-84 Compressor ON Time		
Array [2]		
Range:	Function:	
0 h*	[0 - 2147483647 h]	Readout of the value for compressor ON time. The pack controller has separate counters for the compressors and for the relays that control the compressors. Compressor ON time monitors the operating hours of each compressor. The value of each compressor ON time counter can be reset to 0 by writing in the parameter, for example, if the compressor is replaced in case of service.

25-85 Relay ON Time

Array [2]

0 h*	[0 – 2147483647 h]	Readout of the value for relay ON time. The pack controller has separate counters for the compressors and for the relays that control the compressors. Compressor cycling is always done based on the relay counters, otherwise it would always use the new compressor if a compressor is replaced and its value in <i>parameter 25-84 Compressor ON Time</i> is reset. To use <i>parameter 25-04 Pump Cycling</i> , the pack controller is monitoring the relay ON time.
---------	--------------------------	---

25-86 Reset Relay Counters

Option: **Function:**

[0] *	Do not reset	
[1]	Do reset	Resets all elements in <i>parameter 25-85 Relay ON Time</i> .

25-87 Inverse Interlock

Shows the inverse interlock status of the connected compressors. The binary value shows compressor 1 rightmost and compressor 8 leftmost.

Range: **Function:**

0*	[0 - 255]	
----	-----------	--

25-88 Pack capacity [%]

Shows how much current the configured pack of compressors or condensers utilizes.

Range: **Function:**

0 %*	[0 - 0 %]	
------	-----------	--

3.20.8 25-9* Service

Parameters used in case of service on 1 or more of the compressors controlled.

25-90 Compressor Interlock

Array [2]

Option: **Function:**

		In this parameter, it is possible to disable 1 or more of the fixed lead compressors. For example, the compressor is not selected for staging even if it is the next compressor in the operation sequence. It is not possible to disable the lead compressor with the compressor interlock command. The digital input interlocks are selected as <i>[130 – 132] Compressor 1-3 Interlock</i> in <i>parameter group 5-1* Digital Inputs</i> .
[0] *	Off	The compressor is active for staging/destaging.
[1]	On	The compressor interlock command is given. If a compressor is running, it is immediately destaged. If the compressor is not running, it is not allowed to stage.

25-91 Manual Alternation

Range: **Function:**

0*	[0 - par. 25-06]	Readout parameter for the actual variable speed pump in the system. When an alternation takes place, the lead pump parameter is updated to reflect the current variable speed pump in the system. If no lead pump is selected (cascade controller disabled or all pumps interlocked), the display shows N1.
----	---------------------	---

3.21 Parameters: 26-** Analog I/O Option
MCB 109

3.21.1 26-** Analog I/O Option MCB 109

3

VLT® Analog I/O Option MCB 109 extends the functionality of VLT® Refrigeration Drive FC 103 frequency converters, by adding a number of additional, programmable analog inputs and outputs. This could be especially useful in building management system installations where the frequency converter may be used as decentral I/O, obviating the need for an outstation and thus reducing cost.

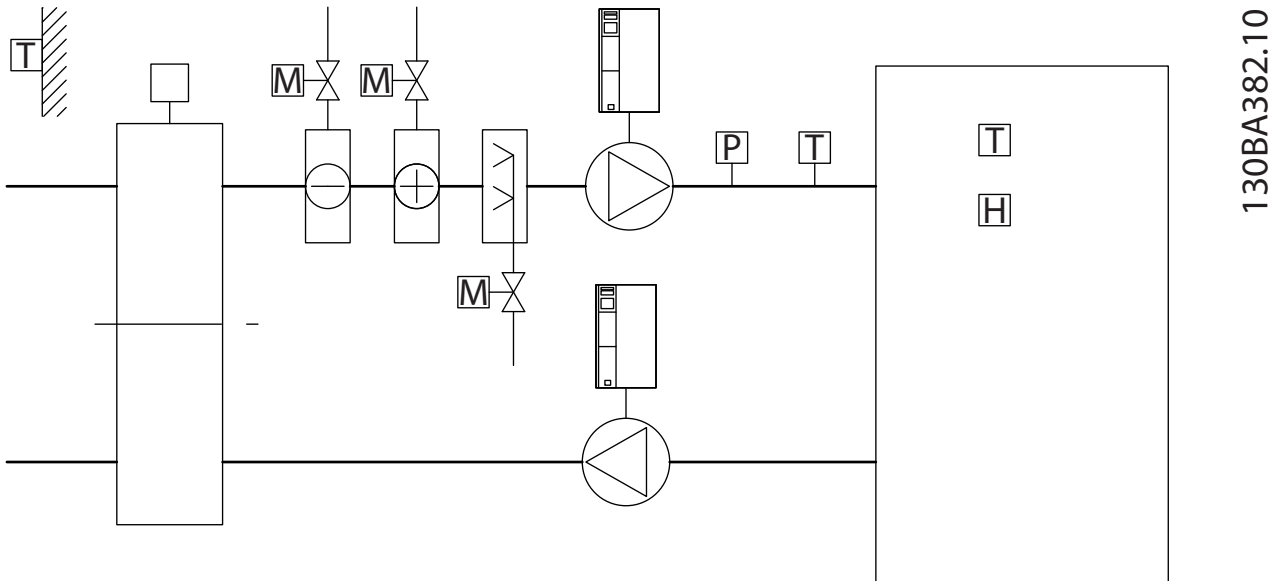

Illustration 3.68 Analog I/O Option MCB 109

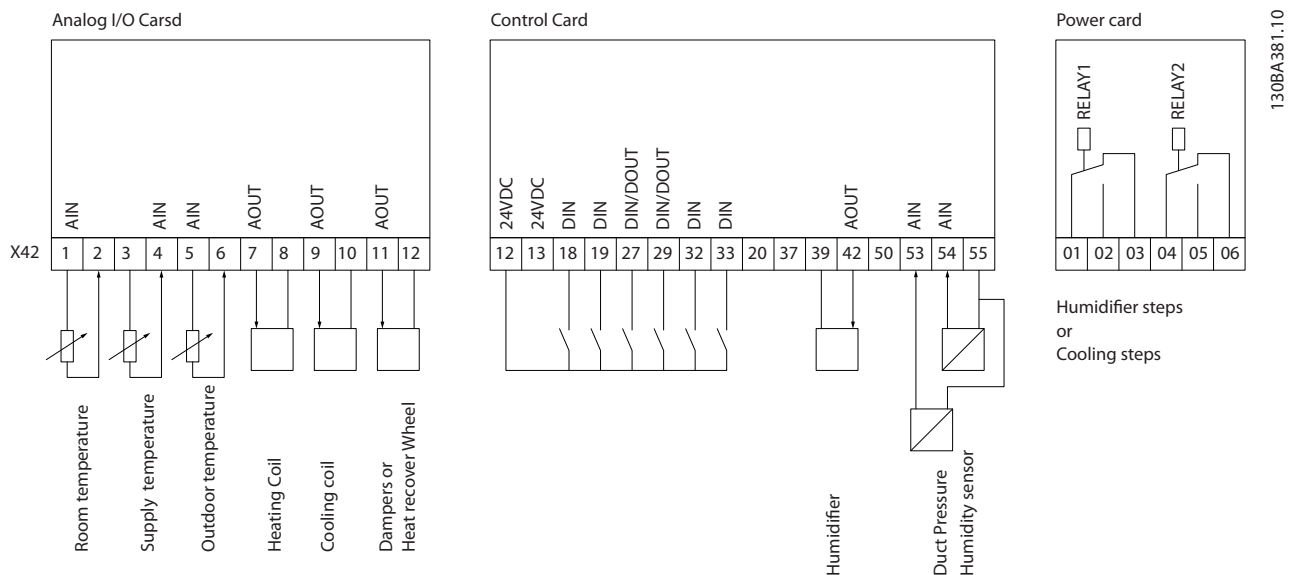

Illustration 3.69 Analog I/O Option MCB 109

Illustration 3.68 shows a typical air handling unit (AHU). As can be seen, the addition of the analog I/O option offers the possibility to control all of the functions from the frequency converter, such as inlet-, return- and exhaust dampers, or heating/cooling coils with temperature and pressure measurements being read by the frequency converter.

NOTICE

The maximum current for the analog outputs 0–10 V is 1 mA.

NOTICE

Where live zero monitoring is used, it is important that any analog inputs not being used for the frequency converter, that is, being used as part of the building management system decentral I/O, should have their live zero-function disabled.

Terminal	Parameters	Terminal	Parameters	Terminal	Parameters
Analog inputs		Analog inputs		Relays	
X42/1	Parameter 26-00 Terminal X42/1 Mode, 26-1*	53	6-1*	Relay 1 terminal 1, 2, 3	5-4*
X42/3	Parameter 26-01 Terminal X42/3 Mode, 26-2*	54	6-2*	Relay 2 terminal 4, 5, 6	5-4*
X42/5	Parameter 26-02 Terminal X42/5 Mode, 26-3*	–	–	–	–
Analog outputs		Analog output			
X42/7	26-4*	42	6-5*	–	–
X42/9	26-5*	–	–	–	–
X42/11	26-6*	–	–	–	–

Table 3.23 Relevant Parameters

It is also possible to read the analog inputs, write to the analog outputs, and control the relays, using communication via the serial bus. In this instance, these are the relevant parameters.

Terminal	Parameters	Terminal	Parameters	Terminal	Parameters
Analog inputs (read)		Analog inputs (read)		Relays	
X42/1	Parameter 18-30 Analog Input X42/1	53	Parameter 16-62 Analog Input 53	Relay 1 terminal 1, 2, 3	Parameter 16-71 Relay Output [bin]
X42/3	Parameter 18-31 Analog Input X42/3	54	Parameter 16-64 Analog Input 54	Relay 2 terminal 4, 5, 6	Parameter 16-71 Relay Output [bin]
X42/5	Parameter 18-32 Analog Input X42/5	–	–	–	–
Analog outputs (write)		Analog output (write)			
X42/7	Parameter 18-33 Analog Out X42/7 [V]	42	Parameter 6-53 Terminal 42 Output Bus Control	<p>NOTICE Enable the relay outputs via control word bit 11 (relay 1) and bit 12 (relay 2).</p>	
X42/9	Parameter 18-34 Analog Out X42/9 [V]	–	–		
X42/11	Parameter 18-35 Analog Out X42/11 [V]	–	–		

Table 3.24 Relevant Parameters

Setting of on-board real-time clock

The analog I/O option incorporates a real-time clock with battery back-up. This can be used as back-up of the clock function included in the frequency converter as standard. See *chapter 3.2.7 0-7* Clock Settings*.

The analog I/O option can be used for the control of devices such as actuators or valves using the extended closed-loop facility, thus removing control from the building management system. See *parameter group 21-** Extended Closed Loop*. There are 3 independent closed-loop PID controllers.

26-00 Terminal X42/1 Mode	
Option:	Function:
	<p>Terminal X42/1 can be programmed as an analog input accepting a voltage or input from either Pt1000 (1000 Ω at 0 °C (32 °F)) or Ni 1000 (1000 Ω at 0 °C (32 °F)) temperature sensors. Select the mode.</p> <p>[2] Pt 1000 [°C] and [4] Ni 1000 [°C] if operating in Celsius, or [3] Pt 1000 [°F] and [5] Ni 1000 [°F] if operating in Fahrenheit.</p> <p>NOTICE</p> <p>If the input is not in use, set it for voltage.</p> <p>If set for temperature and used as feedback, set the unit for either Celsius or Fahrenheit.</p> <ul style="list-style-type: none"> Parameter 20-12 Reference/Feedback Unit. Parameter 21-10 Ext. 1 Ref./Feedback Unit. Parameter 21-30 Ext. 2 Ref./Feedback Unit. Parameter 20-05 Feedback 2 Source Unit.
[1] *	Voltage
[2]	Pt 1000 [°C]
[3]	Pt 1000 [°F]
[4]	Ni 1000 [°C]
[5]	Ni 1000 [°F]

26-01 Terminal X42/3 Mode	
Option:	Function:
	<p>Terminal X42/3 can be programmed as an analog input accepting a voltage or input from either Pt 1000 or Ni 1000 temperature sensors. Select the mode.</p> <p>[2] Pt 1000 [°C] and [4] Ni 1000 [°C] if operating in Celsius, or [3] Pt 1000 [°F] and [5] Ni 1000 [°F] if operating in Fahrenheit.</p> <p>NOTICE</p> <p>If the input is not in use, set it for voltage.</p> <p>If set for temperature and used as feedback, set the unit for either Celsius or Fahrenheit</p> <ul style="list-style-type: none"> Parameter 20-12 Reference/Feedback Unit. Parameter 21-10 Ext. 1 Ref./Feedback Unit. Parameter 21-30 Ext. 2 Ref./Feedback Unit.

26-01 Terminal X42/3 Mode	
Option:	Function:
	<ul style="list-style-type: none"> Parameter 20-05 Feedback 2 Source Unit.
[1] *	Voltage
[2]	Pt 1000 [°C]
[3]	Pt 1000 [°F]
[4]	Ni 1000 [°C]
[5]	Ni 1000 [°F]

26-02 Terminal X42/5 Mode	
Option:	Function:
	<p>Terminal X42/5 can be programmed as an analog input accepting a voltage or input from either Pt 1000 (1000 Ω at 0 °C) or Ni 1000 (1000 Ω at 0 °C) temperature sensors. Select the mode.</p> <p>[2] Pt 1000 [°C] and [4] Ni 1000 [°C] if operating in Celsius, or [3] Pt 1000 [°F] and [5] Ni 1000 [°F] if operating in Fahrenheit.</p> <p>NOTICE</p> <p>If the input is not in use, set it for voltage.</p> <p>If set for temperature and used as feedback, set the unit for either Celsius or Fahrenheit:</p> <ul style="list-style-type: none"> Parameter 20-12 Reference/Feedback Unit. Parameter 21-10 Ext. 1 Ref./Feedback Unit. Parameter 21-30 Ext. 2 Ref./Feedback Unit. Parameter 20-05 Feedback 2 Source Unit.
[1] *	Voltage
[2]	Pt 1000 [°C]
[3]	Pt 1000 [°F]
[4]	Ni 1000 [°C]
[5]	Ni 1000 [°F]

3.21.2 26-1* Analog Input X42/1

26-10 Terminal X42/1 Low Voltage	
Range:	Function:
0.07 V* [0 - par. 6-31 V]	Enter the low voltage value. This analog input scaling value should correspond to the low reference/feedback value set in parameter 26-14 Term. X42/1 Low Ref./Feedb. Value.

26-11 Terminal X42/1 High Voltage		
Range:	Function:	
10 V* [par. 6-30 - 10 V]	Enter the high-voltage value. This analog input scaling value should correspond to the high reference/feedback value set in <i>parameter 26-15 Term. X42/1 High Ref./Feedb. Value.</i>	

26-14 Term. X42/1 Low Ref./Feedb. Value		
Range:	Function:	
0* [-999999.999 - 999999.999]	Enter the analog input scaling value that corresponds to the low-voltage value set in <i>parameter 26-10 Terminal X42/1 Low Voltage.</i>	

26-15 Term. X42/1 High Ref./Feedb. Value		
Range:	Function:	
100* [-999999.999 - 999999.999]	Enter the analog input scaling value that corresponds to the high-voltage value set in <i>parameter 26-11 Terminal X42/1 High Voltage.</i>	

26-16 Term. X42/1 Filter Time Constant		
Range:	Function:	
0.001 s* [0.001 - 10 s]	<p>NOTICE</p> <p>This parameter cannot be adjusted while the motor is running.</p> <p>This is a first-order digital low-pass filter time constant for suppressing noise in terminal X42/1. A high time constant value improves dampening, but also increases the time delay through the filter.</p>	

26-17 Term. X42/1 Live Zero		
Option:	Function:	
	This parameter makes it possible to enable the live zero monitoring, for example, where the analog input is the frequency converter control, rather than being used as a decentral I/O system, such as a building management system.	
[0]	Disabled	
[1] *	Enabled	

3.21.3 26-2* Analog Input X42/3

26-20 Terminal X42/3 Low Voltage		
Range:	Function:	
0.07 V* [0 - par. 6-31 V]	Enter the low voltage value. This analog input scaling value should correspond to the low reference/feedback value set in	

26-20 Terminal X42/3 Low Voltage		
Range:	Function:	
	<i>parameter 26-24 Term. X42/3 Low Ref./Feedb. Value.</i>	

26-21 Terminal X42/3 High Voltage		
Range:	Function:	
10 V* [par. 6-30 - 10 V]	Enter the high-voltage value. This analog input scaling value should correspond to the high reference/feedback value set in <i>parameter 26-25 Term. X42/3 High Ref./Feedb. Value.</i>	

26-24 Term. X42/3 Low Ref./Feedb. Value		
Range:	Function:	
0* [-999999.999 - 999999.999]	Enter the analog input scaling value that corresponds to the low voltage value set in <i>parameter 26-20 Terminal X42/3 Low Voltage.</i>	

26-25 Term. X42/3 High Ref./Feedb. Value		
Range:	Function:	
100* [-999999.999 - 999999.999]	Enter the analog input scaling value that corresponds to the high-voltage value set in <i>parameter 26-21 Terminal X42/3 High Voltage.</i>	

26-26 Term. X42/3 Filter Time Constant		
Range:	Function:	
0.001 s* [0.001 - 10 s]	<p>NOTICE</p> <p>This parameter cannot be adjusted while the motor is running.</p> <p>Enter the time constant. This is a first-order digital low-pass filter time constant for suppressing noise in terminal X42/3. A high time constant value improves dampening, but also increases the time delay through the filter.</p>	

26-27 Term. X42/3 Live Zero		
Option:	Function:	
	This parameter makes it possible to enable the live zero monitoring, for example, where the analog input is the frequency converter control, rather than being used as a decentral I/O system, such as a building management system.	
[0]	Disabled	
[1] *	Enabled	

3.21.4 26-3* Analog Input X42/5

26-30 Terminal X42/5 Low Voltage		
Range:	Function:	
0.07 V* [0 - par. 6-31 V]	Enter the low voltage value. This analog input scaling value should correspond to the low reference/feedback value set in <i>parameter 26-34 Term. X42/5 Low Ref./Feedb. Value</i> .	

26-31 Terminal X42/5 High Voltage		
Range:	Function:	
10 V* [par. 6-30 - 10 V]	Enter the high-voltage value. This analog input scaling value should correspond to the high reference/feedback value set in <i>parameter 26-35 Term. X42/5 High Ref./Feedb. Value</i> .	

26-34 Term. X42/5 Low Ref./Feedb. Value		
Range:	Function:	
0* [-999999.999 - 999999.999]	Enter the analog input scaling value that corresponds to the low-voltage value set in <i>parameter 26-30 Terminal X42/5 Low Voltage</i> .	

26-35 Term. X42/5 High Ref./Feedb. Value		
Range:	Function:	
100* [-999999.999 - 999999.999]	Enter the analog input scaling value that corresponds to the high-voltage value set in <i>parameter 26-21 Terminal X42/3 High Voltage</i> .	

26-36 Term. X42/5 Filter Time Constant		
Range:	Function:	
0.001 s* [0.001 - 10 s]	<p>NOTICE</p> <p>This parameter cannot be adjusted while the motor is running.</p> <p>This is a first-order digital low-pass filter time constant for suppressing noise in terminal X42/5. A high time constant value improves dampening, but also increases the time delay through the filter.</p>	

26-37 Term. X42/5 Live Zero		
Option:	Function:	
	Enable or disable the live zero monitoring.	
[0]	Disabled	
[1] *	Enabled	

3.21.5 26-4* Analog Input X42/7

26-40 Terminal X42/7 Output		
Option:	Function:	
		Set the function of terminal X42/7 as an analog current output.
[0] *	No operation	
[100]	Output frequency	0–100 Hz, (0–10 V).
[101]	Reference	Minimum reference–maximum reference, (0–10 V).
[102]	Feedback	-200% to +200% of <i>parameter 3-03 Maximum Reference</i> , (0–10 V).
[103]	Motor Current	0–inverter maximum current (<i>parameter 16-37 Inv. Max. Current</i>), (0–10 V).
[104]	Torque rel to limit	0–torque limit (<i>parameter 4-16 Torque Limit Motor Mode</i>), (0–10 V).
[105]	Torq relate to rated	0–motor rated torque, (0–10 V).
[106]	Power	0–motor rated power, (0–10 V).
[107]	Speed	0–speed high limit (<i>parameter 4-13 Motor Speed High Limit [RPM]</i> and <i>parameter 4-14 Motor Speed High Limit [Hz]</i>), (0–10 V).
[108]	Torque	
[109]	Max Out Freq	
[113]	Ext. Closed Loop 1	0–100%, (0–10 V).
[114]	Ext. Closed Loop 2	0–100%, (0–10 V).
[115]	Ext. Closed Loop 3	0–100%, (0–10 V).
[121]	Air pres. to Flow	
[139]	Bus ctrl.	0–100%, (0–10 V).
[141]	Bus ctrl t.o.	0–100%, (0–10 V).

26-41 Terminal X42/7 Min. Scale		
Range:	Function:	
0 %* [0 - 200 %]	Scale the minimum output of the selected analog signal at terminal X42/7, as a percentage of the maximum signal level, example, if 0 V (or 0 Hz) is required at 25% of the maximum output value, program 25%. Scaling values up to 100% can never be higher than the corresponding setting in <i>parameter 26-42 Terminal X42/7 Max. Scale</i> . See principle graph for <i>parameter 6-51 Terminal 42 Output Min Scale</i> .	

26-42 Terminal X42/7 Max. Scale		
Range:	Function:	
100 %*	[0 - 200 %]	Scale the maximum output of the selected analog signal at terminal X42/7. Set the value to the maximum value of the voltage signal output. Scale the output to give a voltage lower than 10 V at full scale; or 10 V at an output below 100% of the maximum signal value. If 10 V is the required output current at a value between 0–100% of the full-scale output, program the percentage value in the parameter, that is 50%=10 V. If a voltage 0–10 V is required at maximum output, calculate the percentage as follows: $\left(\frac{10V}{\text{desired maximum voltage}} \right) \times 100\%$ that is $5V: \frac{10V}{5V} \times 100\% = 200\%$ See <i>Illustration 3.31</i> .

26-43 Terminal X42/7 Bus Control		
Range:	Function:	
0 %*	[0 - 100 %]	Holds the level of terminal X42/7 if controlled by bus.

26-44 Terminal X42/7 Timeout Preset		
Range:	Function:	
0 %*	[0 - 100 %]	Holds the preset level of terminal X42/7. If a fieldbus and a timeout function are selected in <i>parameter 26-50 Terminal X42/9 Output</i> , the output presets to this level.

26-50 Terminal X42/9 Output		
Option:	Function:	
[106]	Power	0–motor rated power, (0–10 V).
[107]	Speed	0–speed high limit (<i>parameter 4-13 Motor Speed High Limit [RPM]</i> and <i>parameter 4-14 Motor Speed High Limit [Hz]</i>), (0–10 V).
[108]	Torque	
[109]	Max Out Freq	
[113]	Ext. Closed Loop 1	0–100%, (0–10 V).
[114]	Ext. Closed Loop 2	0–100%, (0–10 V).
[115]	Ext. Closed Loop 3	0–100%, (0–10 V).
[121]	Air pres. to Flow	
[139]	Bus ctrl.	0–100%, (0–10 V).
[141]	Bus ctrl t.o.	0–100%, (0–10 V).

26-51 Terminal X42/9 Min. Scale		
For more information, see <i>parameter 6-51 Terminal 42 Output Min Scale</i> .		
Range:	Function:	
0 %*	[0 - 200 %]	Scale the minimum output of the selected analog signal at terminal X42/9, as a percentage of the maximum signal level, example, if 0 V is required at 25% of the maximum output value, program 25%. Scaling values up to 100% can never be higher than the corresponding setting in <i>parameter 26-52 Terminal X42/9 Max. Scale</i> .

3.21.6 26-5* Analog Input X42/9

26-50 Terminal X42/9 Output		
Option:	Function:	
		Set the function of terminal X42/9.
[0] *	No operation	
[100]	Output frequency	0–100 Hz, (0–10 V).
[101]	Reference	Minimum reference–maximum reference, (0–10 V).
[102]	Feedback	-200% to +200% of <i>parameter 3-03 Maximum Reference</i> , (0–10 V).
[103]	Motor Current	0–inverter maximum current (<i>parameter 16-37 Inv. Max. Current</i>), (0–10 V).
[104]	Torque rel to limit	0–torque limit (<i>parameter 4-16 Torque Limit Motor Mode</i>), (0–10 V).
[105]	Torq relate to rated	0–motor rated torque, (0–10 V).

26-52 Terminal X42/9 Max. Scale		
See <i>Illustration 3.31</i> .		
Range:	Function:	
100 %*	[0 - 200 %]	Scale the maximum output of the selected analog signal at terminal X42/9. Set the value to the maximum value of the voltage signal output. Scale the output to give a voltage lower than 10 V at full scale; or 10 V at an output below 100% of the maximum signal value. If 10 V is the required output current at a value between 0–100% of the full-scale output, program the percentage value in the parameter, that is, 50%=10 V. If a voltage 0–10 V is required at maximum output, calculate the percentage as follows: that is $5V: \frac{10V}{5V} \times 100\% = 200\%$

26-53 Terminal X42/9 Bus Control		
Range:	Function:	
0 %*	[0 - 100 %]	Holds the level of terminal X42/9 if controlled by bus.

26-54 Terminal X42/9 Timeout Preset		
Range:		Function:
0 %*	[0 - 100 %]	Holds the preset level of terminal X42/9. If a fieldbus and a timeout function are selected in <i>parameter 26-60 Terminal X42/11 Output</i> , the output presets to this level.

3.21.7 26-6* Analog Input X42/11

26-60 Terminal X42/11 Output		
Option:		Function:
		Set the function of terminal X42/11.
[0] *	No operation	
[100]	Output frequency	0–100 Hz, (0–10 V).
[101]	Reference	Minimum reference–maximum reference, (0–10 V).
[102]	Feedback	-200% to +200% of <i>parameter 3-03 Maximum Reference</i> , (0–10 V).
[103]	Motor Current	0–inverter maximum current (<i>parameter 16-37 Inv. Max. Current</i>), (0–10 V).
[104]	Torque rel to limit	0–torque limit (<i>parameter 4-16 Torque Limit Motor Mode</i>), (0–10 V).
[105]	Torq relate to rated	0–motor rated torque, (0–0 V).
[106]	Power	0–motor rated power, (0–10 V).
[107]	Speed	0–speed high limit (<i>parameter 4-13 Motor Speed High Limit [RPM]</i> and <i>parameter 4-14 Motor Speed High Limit [Hz]</i>), (0–10 V).
[108]	Torque	
[109]	Max Out Freq	
[113]	Ext. Closed Loop 1	0–100%, (0–10 V).
[114]	Ext. Closed Loop 2	0–100%, (0–10 V).
[115]	Ext. Closed Loop 3	0–100%, (0–10 V).
[121]	Air pres. to Flow	
[139]	Bus ctrl.	0–100%, (0–10 V).
[141]	Bus ctrl t.o.	0–100%, (0–10 V).

26-61 Terminal X42/11 Min. Scale		
For more information, see <i>parameter 6-51 Terminal 42 Output Min Scale</i> .		
Range:		Function:
0 %*	[0 - 200 %]	Scale the minimum output of the selected analog signal at terminal X42/11 as a percentage of the maximum signal level. For

26-61 Terminal X42/11 Min. Scale		
For more information, see <i>parameter 6-51 Terminal 42 Output Min Scale</i> .		
Range:		Function:
		example, if 0 V is required at 25% of the maximum output value, program 25%. Scaling values up to 100% can never be higher than the corresponding setting in <i>parameter 26-62 Terminal X42/11 Max. Scale</i> .

26-62 Terminal X42/11 Max. Scale		
See <i>Illustration 3.31</i> .		
Range:		Function:
100 %*	[0 - 200 %]	Scale the maximum output of the selected analog signal at terminal X42/9. Set the value to the maximum value of the voltage signal output. Scale the output to give a voltage lower than 10 V at full scale; or 10 V at an output below 100% of the maximum signal value. For example, if 10 V is the required output current at a value between 0–100% of the full-scale output, program the percentage value in the parameter, that is, 50%=10 V. If a voltage 0–10 V is required at maximum output, calculate the percentage as follows: $\left(\frac{10V}{\text{desired maximum voltage}}\right) \times 100\%$ that is $5V: \frac{10V}{5V} \times 100\% = 200\%$

26-63 Terminal X42/11 Bus Control		
Range:		Function:
0 %*	[0 - 100 %]	Holds the level of terminal X42/11 if controlled by bus.

26-64 Terminal X42/11 Timeout Preset		
Range:		Function:
0 %*	[0 - 100 %]	Holds the preset level of terminal X42/11. If a fieldbus and a timeout function are selected, the output presets to this level.

3.22 Parameters: 28-** Compressor Functions

3.22.1 28-1* Oil Return Management

Insufficient lubrication can be the result of oil deposits in pipes and bends. To avoid oil deposits, increase velocity for short periods at regular time intervals or ensure adequate oil return when velocity is too low.

Oil return management allows to program oil return mechanisms. With oil return management enabled, the frequency converter performs oil return by boosting the compressor speed to 4200 RPM (70 Hz) for a selected duration. Program the duration in *parameter 28-13 Boost Duration*. The boosts are performed at fixed time intervals (programmed in *parameter 28-12 Fixed Boost Interval*) or if the compressor speed is less than 3000 RPM (50 Hz) for a time longer than selected in *parameter 28-11 Low Speed Running Time*, whichever occurs first. The maximum time between 2 consecutive oil return boosts is defined in *parameter 28-12 Fixed Boost Interval*. A text message on the LCP indicates oil return boosts.

NOTICE

If *parameter 4-13 Motor Speed High Limit [RPM]* or *parameter 4-14 Motor Speed High Limit [Hz]* is set to the boost speed 4200 RPM, an oil boost may cause unwanted staging or destaging if *parameter group 25-** Pack Controller* is active.

28-10 Oil Return Management

Option: **Function:**

[0] *	Off	No function
[1]	On	Oil return mechanism is active.

28-11 Low Speed Running Time

Range: **Function:**

60 min*	[1 – 1440 min]	Running at low speeds for extended periods may result in inadequate oil return to the compressor crankcase. Set this parameter to the maximum running time the compressor is allowed to run at a speed below 3000 RPM/50 Hz. An oil return boost is performed each time the compressor is running at a low speed for this time.
---------	----------------	---

28-12 Fixed Boost Interval

Range: **Function:**

24 h *	[1 – 168 h]	An oil return boost is performed at fixed time intervals to complement the oil return boosts triggered by inadequate flow speeds (<i>parameter 28-11 Low Speed Running Time</i>). The fixed interval boosts ensure that oil return boosts are performed even when no boosts occurred
--------	-------------	--

28-12 Fixed Boost Interval

Range: **Function:**

		due to low flow speed (<i>parameter 28-11 Low Speed Running Time</i>).
--	--	--

28-13 Boost Duration

Range: **Function:**

30 s *	[10 – 120 s]	Enter the duration of oil return boosts.
--------	--------------	--

28-14 Adequate oil return speed [RPM]

Enter the minimum speed at which the oil is returned to the compressor. If the speed is lower than this value, the frequency converter triggers the ORM function.

Range: **Function:**

Size related*	[0 - par. 28-16 RPM]	
---------------	----------------------	--

28-15 Adequate oil return speed [Hz]

Enter the minimum speed at which the oil is returned to the compressor. If the speed is lower than this value, the frequency converter triggers the ORM function.

Range: **Function:**

Size related*	[0 - par. 28-17 Hz]	
---------------	---------------------	--

28-16 Oil boost speed [RPM]

Enter the speed to which the frequency converter speeds up when it returns oil to the compressor.

Range: **Function:**

Size related*	[par. 28-14 - par. 4-13 RPM]	
---------------	-------------------------------	--

28-17 Oil boost speed [Hz]

Enter the speed to which the frequency converter speeds up when it returns oil to the compressor.

Range: **Function:**

Size related*	[par. 28-15 - par. 4-14 Hz]	
---------------	------------------------------	--

28-18 Cancel oil boost at low feedback

Enter the minimum feedback level at which the oil boost functions. If the feedback level is lower than the value of this parameter, the oil boost is canceled.

Range: **Function:**

-999999.999	[-999999.999 - par. 28-19 ProcessCtrlUnit]	
ProcessCtrlUnit*		

28-19 Cancel oil boost at high feedback

Enter the maximum feedback level at which the oil boost functions. If the feedback level exceeds the value of this parameter, the oil boost is canceled.

Range: **Function:**

999999.999	[par. 28-18 - 999999.999	
ProcessCtrlUnit*	ProcessCtrlUnit]	

3.22.2 28-2* Discharge Temperature Monitor

Use the discharge temperature monitor (DTM) to prevent the discharge temperature from reaching dangerous levels.

3

Two temperature levels of increasing severity can be programmed. These levels are warning level (set in *parameter 28-24 Warning Level*) and emergency level (set in *parameter 28-26 Emergency Level*) in the order of increasing severity. Each level corresponds to a particular set of preventive actions.

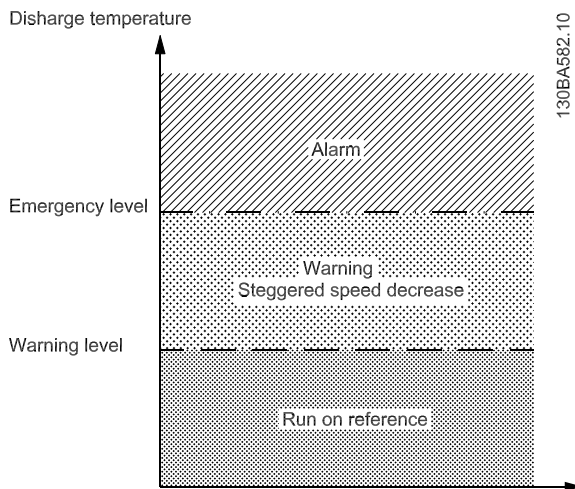

Illustration 3.70 Discharge Temperature Levels

To prevent damaging the compressor, discharge temperatures above the emergency level cause an alarm and an immediate trip.

Discharge temperatures below warning level are normal. The discharge temperature is passively monitored without affecting frequency converter operations.

Discharge temperatures in the range from warning level to emergency level trigger a warning and an action set by *parameter 28-25 Warning Action*. The action can be [0] No action or [1] Decrease cooling. If the option is [1] Decrease cooling, the cooling is decreased as a preventive action in an attempt to lower the discharge temperature.

The [1] Decrease cooling option lowers the shaft speed step-wise until the discharge temperature either drops below the warning level or exceeds the emergency level. Each step represents a 3-minute period during which the maximum allowed shaft speed is 10 Hz lower than the previous step. The initial step occurs when the discharge temperature rises above the warning level. The current

shaft speed becomes the basis for the 10 Hz speed reduction.

The speed steps enforce maximum shaft speeds. If the reference corresponds to a lesser speed, the frequency converter sets the speed to the reference. If the reference corresponds to a higher speed, the speed is limited to the maximum shaft speed for the current step.

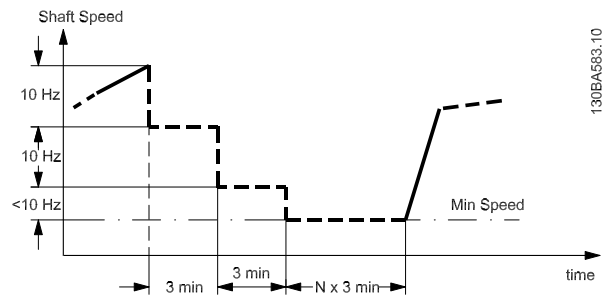

Illustration 3.71 Speed Steps

NOTICE

If the pack controller is active, unwanted staging or destaging may occur if the discharge temperature monitor reduces the speed to *parameter 4-11 Motor Speed Low Limit [RPM]* or *parameter 4-12 Motor Speed Low Limit [Hz]*.

28-20 Temperature Source

Option: Function:

		Select the input terminal to which the discharge temperature measurement device is connected.
[0]	None	No source. The discharge temperature monitor is not active.
[1]	Analog input 53	The measurement device is connected to input terminal 53. Program <i>parameter 6-10 Terminal 53 Low Voltage</i> to <i>parameter 6-15 Terminal 53 High Ref./Feedb. Value</i> to match the characteristics of the device.
[2]	Analog input 54	The measurement device is connected to input terminal 54. Program <i>parameter 6-20 Terminal 54 Low Voltage</i> to <i>parameter 6-25 Terminal 54 High Ref./Feedb. Value</i> to match the characteristics of the device.

28-21 Temperature Unit

Option: Function:

		Selects the unit of the discharge temperature.
[60]	*	°C
[160]		°F

28-24 Warning Level
Range:
Function:

130*	[10– <i>parameter 28-26 Emergency Level</i>]	Select the temperature at which a warning is issued. The action selected in <i>parameter 28-25 Warning Action</i> becomes active at this temperature. Enter the temperature in the unit selected in <i>parameter 28-21 Temperature Unit</i> .
------	--	---

28-25 Warning Action
Option:
Function:

		Select what the frequency converter does for discharge temperatures above the value programmed in <i>parameter 28-21 Temperature Unit</i> but below the value programmed in <i>parameter 28-26 Emergency Level</i> .
[0]	None	No action. Only a warning is issued.
[1]*	Decrease cooling	A warning is issued and the motor speed is lowered in steps of 10 Hz every 3 minutes until the temperature either drops below the level programmed in <i>parameter 28-24 Warning Level</i> or exceeds the level programmed in <i>parameter 28-26 Emergency Level</i> .

28-26 Emergency Level
Range:
Function:

145*	[<i>parameter 28-24 Warning Level</i> -300]	Enter the temperature at which an alarm is issued. Enter the temperature in the unit programmed in <i>parameter 28-21 Temperature Unit</i> .
------	--	--

28-27 Discharge Temperature
Range:
Function:

0*	[-2147483648 – 2147483648]	Returns the actual value of the discharge temperature.
----	----------------------------	--

3.22.3 28-7* Day/Night Control

In the day-night control mode, the compressor runs at a normal speed during the day time and with increased setpoint during night time. The condenser fans run at normal speed during the day time and with reduced maximum speed limit during the night time. There are 3 sources of day or night indication in the frequency converter. They are: Digital input (*parameter group 5-1* Digital Inputs*), timed actions (*parameter group 23-** Time-based Functions*), and LON bus (*parameter group 28-7* Day/Night Settings*).

The day-night control action is active if *parameter 20-25 Setpoint Type* is set to [1] *Fixed with Night Setback*.

28-71 Day/ Night Bus Indicator
Range:
Function:

0*	[0 - 1]	This parameter receives signals from the LON bus periodically to indicate day or night. This is a read-only parameter on LCP. 1 indicates night and 0 indicates day.
----	---------	--

28-72 Enable Day/ Night via Bus
Range:
Function:

0*	[0 - 1]	This parameter enables or disables <i>parameter 28-71 Day/Night Bus Indicator</i> . If this parameter is set to [0] <i>Disable</i> then the value in <i>parameter 28-71 Day/Night Bus Indicator</i> is discarded in day-night control. If this parameter is set to [1] <i>Enable</i> then the value in <i>parameter 28-71 Day/Night Bus Indicator</i> is considered in day-night control. Use a fieldbus or digital inputs for the day-night indication.
----	---------	--

28-73 Night Setback
Range:
Function:

0*	[0 – (3-03 – 3-02)]	Enter the value by which the compressor setpoint increases during night.
----	----------------------	--

28-74 Night Speed Drop
Range:
Function:

0*	[0 – (4-13 – 4-11)]	Enter the value by which the maximum speed limit of the condenser fans is lowered during night. The range of the value is from 0 to difference of <i>parameter 4-13 Motor Speed High Limit [RPM]</i> and <i>parameter 4-11 Motor Speed Low Limit [RPM]</i> .
----	----------------------	--

28-75 Night Speed Drop Override
Range:
Function:

0*	[-1000000.000 – 1000000.000]	Enter the limit for the condenser feedback (pressure) when the night action is active. If condenser feedback is more than the value in this parameter, the night action is deactivated (if already active) and day action is activated. Value 0 in this parameter means that night speed drop is active regardless of the condenser pressure.
----	-------------------------------	---

28-76 Night Speed Drop [Hz]

Enter the maximum speed limit decrement that becomes active at night.

Range:
Function:

Size related*	[0 - 50 Hz]	
---------------	--------------	--

3.22.4 28-8* P0 Optimization

VLT® Refrigeration Drive FC 103 supports the VLT® Refrigeration Drive P0 Optimization feature. This enables automatic adaptation of the suction pressure to match the actual load on the system.

To enable this function, set *parameter 20-25 Setpoint Type* to [2] *Floating*. The frequency converter now accepts setpoint changes from the LON bus. The frequency converter ensures the minimum and maximum limits for the feedback suction pressure.

28-81 dP0 Offset

Range:	Function:
-999999.9 - 999999.9	□ The value of the parameter is added to the setpoint if <i>parameter 20-25 Setpoint Type</i> is set to [2] <i>Floating</i> . The unit of the parameter is shown as °K. The feedback is expected to be a pressure converted to an equivalent temperature via the pressure-to-temperature conversion functions available in <i>parameter 20-01 Feedback 1 Conversion</i> , <i>parameter 20-03 Feedback 2 Source</i> , or <i>parameter 20-06 Feedback 3 Source</i> .

28-82 P0

Range:	Function:
-999999.999 - 999999.999	□ The feedback pressure measured on the analog inputs, converted to an equivalent temperature.

28-83 P0 Setpoint

Range:	Function:
-999999.999 - 999999.999	□ The setpoint of the frequency converter excluding any offset in <i>parameter 28-81 dP0 Offset</i> .

28-84 P0 Reference

Range:	Function:
-999999.999 - 999999.999	□ The sum of the setpoint of the frequency converter (<i>parameter 28-83 P0 Setpoint</i>) and the offset in <i>parameter 28-81 dP0 Offset</i> .

28-85 P0 Minimum Reference

Range:	Function:
-999999 - 999999	□ The largest negative offset value that can be entered in <i>parameter 28-81 dP0 Offset</i> without exceeding the minimum reference value in <i>parameter 3-02 Minimum Reference</i> . The value is rounded to the nearest larger integer. If a numerically larger value is entered, the sum of the offset and the setpoint is clipped to the value of <i>parameter 3-02 Minimum Reference</i> .

28-86 P0 Maximum Reference

Range:	Function:
-999999 - 999999	□ The largest positive offset value that can be entered in <i>parameter 28-81 dP0 Offset</i> without exceeding the maximum reference value in <i>parameter 3-03 Maximum Reference</i> . The value is rounded to the nearest smaller integer. If a numerically larger value is entered, the sum of the offset and the setpoint is clipped to the value of <i>parameter 3-03 Maximum Reference</i> .

28-87 Most Loaded Controller

Range:	Function:
0*	[0 - 120]

Shows the number of the controller that is loaded the most.

3.22.5 28-9* Injection Control

The injection on/off signal is a forced close signal for the case controllers (controllers that turn display cases off). The signal is distributed by the following means: Hard-wired through a digital output/relay or soft-wired via fieldbus by gateway or system manager.

28-90 injection_on

Range:	Function:
0*	[0 - 1]

Sends the injection on/off signal over the LON bus. Value 0 stands for injection OFF, value 1 stands for injection ON.

28-91 Delayed Compressor Start

Range:	Function:
0*	[0 - 1]

If this parameter is set to 1, the injection control feature controls the delayed start of the compressor using *parameter 1-71 Start Delay*. If this parameter is set to 0, only *parameter 1-71 Start Delay* controls the delayed start of the compressor. If *parameter 28-91 Delayed Compressor Start* is set to 1 and injection is OFF, the start of the compressor is delayed by the time set in *parameter 1-71 Start Delay*. If *parameter 28-91 Delayed Compressor Start* is set to 1 and injection is ON, the start of the compressor is not delayed. If *parameter 28-91 Delayed Compressor Start* is set to 0, the injection controller feature does not affect the delayed start of the compressor. Delayed start of the compressor is not active during the short cycle protection.

3.23 Parameters: 29-** Application Functions

3.23.1 29-4* Pre/Post-Lube Function

Use the pre/post-lube function in the following applications:

- A motor requires lubrication of its mechanical parts before and while it runs to prevent damage and wear. This is especially the case when the motor has not been running for a long time.
- An application requires external fans to run.

The function makes the frequency converter signal an external device for a user-defined period of time. A start delay can be configured with *parameter 1-71 Start Delay*. With this delay the pre-lube function runs while the motor is stopped.

For information about the pre/post lube function options, see the following parameters:

- *Parameter 29-40 Pre/Post Lube Function.*
- *Parameter 29-41 Pre Lube Time.*
- *Parameter 29-42 Post Lube Time.*

Consider the following use case:

- A lubricating device starts the lubrication at the time when the frequency converter receives the start command.
- The frequency converter starts the motor. The lubrication device is still running.
- After a certain time, the frequency converter stops the lubrication device.

See *Illustration 3.72*.

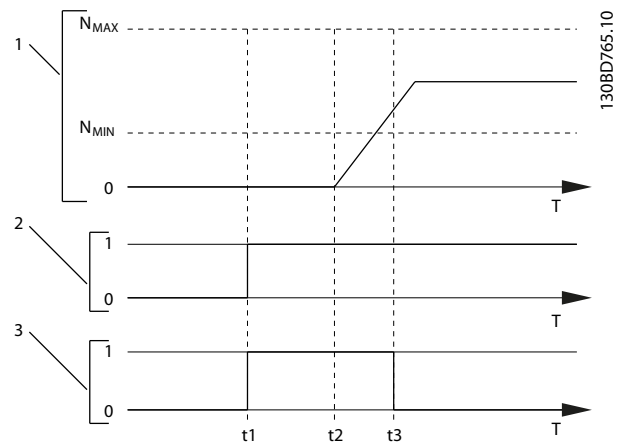

1	Speed curve
2	Start command (for example terminal 18)
3	Pre-lube output signal
t ₁	Start command issued (for example terminal 18 is set active). The start delay timer (<i>parameter 1-71 Start Delay</i>) and the pre-lube timer (<i>parameter 29-41 Pre Lube Time</i>).
t ₂	The start delay timer expires. The frequency converter starts to ramp up.
t ₃	The pre-lube timer (<i>parameter 29-41 Pre Lube Time</i>) expires.

Illustration 3.72 Pre/Post Lube Function Example

29-40 Pre/Post Lube Function		
Select when the pre/post-lube function is active. Use <i>parameter 1-71 Start Delay</i> to set the delay before the frequency converter starts to ramp up.		
Option:	Function:	
[0] *	Disabled	
[1]	Pre Lube Only	
[2]	Pre & Running	
[3]	Pre & Running & Post	

29-41 Pre Lube Time		
Range:	Function:	
10 s* [0 - 600 s]	Enter how long the pre-lube function is active. Use only when option [1] <i>Pre Lube Only</i> is selected in <i>parameter 29-40 Pre/Post Lube Function</i> .	

29-42 Post Lube Time		
Range:	Function:	
10 s* [0 - 600 s]	Enter how long the post-lube function is on after the motor stops. Use only when option [3] <i>Pre & Running & Post</i> is selected in <i>parameter 29-40 Pre/Post Lube Function</i> .	

3.24 Parameters: 30-** Special Features

30-22 Locked Rotor Protection		
Available for PM motors only, in VVC ⁺ open-loop mode.		
Option: Function:		
[0]	Off	
[1]	On	Protects the motor from the locked rotor condition. The control algorithm detects a possible locked rotor condition in motor and trips the frequency converter to protect the motor.

30-23 Locked Rotor Detection Time [s]		
Available for PM motors only, in flux sensorless-mode and VVC ⁺ open-loop mode.		
Range:		Function:
Size related*	[0.05 - 1 s]	Time period for detecting the locked rotor condition. A low parameter value leads to faster detection.

30-30 Pressure Transmitter		
Select which input the frequency converter uses for high and low pressure monitoring.		
Option:		Function:
[0] *	No function	
[1]	Analog Input 53	
[2]	Analog Input 54	
[7]	Analog Input X30/11	
[8]	Analog Input X30/12	
[9]	Analog Input X42/1	
[10]	Analog Input X42/3	
[11]	Analog Input X42/5	

30-31 Pressure Conversion		
Select how the frequency converter converts the signal from analog inputs. [0] <i>Linear</i> - the output is proportional to the input. [1] <i>Square root</i> - square root conversion is applied. [2] <i>Pressure to temperature</i> - the pressure is converted to temperature using refrigerant in <i>parameter 20-30 Refrigerant</i> and using temperature unit in <i>parameter 30-33 Temperature Unit</i> .		
Option:		Function:
[0] *	Linear	
[1]	Square root	
[2]	Pressure to temperature	

30-32 Pressure Source Unit		
Select the unit for pressure source monitoring.		
Option:		Function:
[0]		
[1]	%	
[5]	PPM	
[10]	1/min	
[11]	RPM	
[12]	Pulse/s	
[20]	l/s	

30-32 Pressure Source Unit		
Select the unit for pressure source monitoring.		
Option:		Function:
[21]	l/min	
[22]	l/h	
[23]	m ³ /s	
[24]	m ³ /min	
[25]	m ³ /h	
[30]	kg/s	
[31]	kg/min	
[32]	kg/h	
[33]	t/min	
[34]	t/h	
[40]	m/s	
[41]	m/min	
[45]	m	
[60]	°C	
[70]	mbar	
[71] *	bar	
[72]	Pa	
[73]	kPa	
[74]	m WG	
[80]	kW	
[120]	GPM	
[121]	gal/s	
[122]	gal/min	
[123]	gal/h	
[124]	CFM	
[125]	ft ³ /s	
[126]	ft ³ /min	
[127]	ft ³ /h	
[130]	lb/s	
[131]	lb/min	
[132]	lb/h	
[140]	ft/s	
[141]	ft/min	
[145]	ft	
[160]	°F	
[170]	psi	
[171]	lb/in ²	
[172]	in WG	
[173]	ft WG	
[180]	HP	

30-33 Temperature Unit		
Select the temperature unit for pressure to temperature conversion in <i>parameter 30-31 Pressure Conversion</i> .		
Option:		Function:
[0]		
[1]	%	
[5]	PPM	
[10]	1/min	
[11]	RPM	
[12]	Pulse/s	

30-33 Temperature Unit		
Select the temperature unit for pressure to temperature conversion in <i>parameter 30-31 Pressure Conversion</i> .		
Option:	Function:	
[20]	l/s	
[21]	l/min	
[22]	l/h	
[23]	m ³ /s	
[24]	m ³ /min	
[25]	m ³ /h	
[30]	kg/s	
[31]	kg/min	
[32]	kg/h	
[33]	t/min	
[34]	t/h	
[40]	m/s	
[41]	m/min	
[45]	m	
[60]	°C	
[70]	mbar	
[71]	bar	
[72]	Pa	
[73]	kPa	
[74]	m WG	
[80]	kW	
[120]	GPM	
[121]	gal/s	
[122]	gal/min	
[123]	gal/h	
[124]	CFM	
[125]	ft ³ /s	
[126]	ft ³ /min	
[127]	ft ³ /h	
[130]	lb/s	
[131]	lb/min	
[132]	lb/h	
[140]	ft/s	
[141]	ft/min	
[145]	ft	
[160]	°F	
[170]	psi	
[171]	lb/in ²	
[172]	in WG	
[173]	ft WG	
[180]	HP	

30-34 High Pres. Stop		
If pressure or temperature exceeds the value of this parameter, pack is stopped.		
Range:	Function:	
999999.999 HplpResultUnit0*	[par. 30-36 - 999999.999 HplpResultUnit0]	

30-35 High Pres. Start		
If the pack was stopped because pressure or temperature exceeded the value in <i>parameter 30-34 High Pres. Stop</i> , the pressure or temperature must be less than the value in this parameter for the pack to start again.		
Range:	Function:	
Size related*	[par. 30-37 - par. 30-34 HplpResultUnit0]	

30-36 Low Pres. Stop		
If pressure or temperature is lower than the value of this parameter value, pack is stopped.		
Range:	Function:	
-999999.999 HplpResultUnit0*	[-999999.999 - par. 30-34 HplpResultUnit0]	

30-37 Low Pres. Start		
If the pack was stopped because pressure or temperature was lower than the value in <i>parameter 30-36 Low Pres. Stop</i> , the pressure or temperature must exceed the value in this parameter for the pack to start again.		
Range:	Function:	
Size related*	[par. 30-36 - par. 30-35 HplpResultUnit0]	

30-38 Pressure 1		
Shows the calculated pressure or temperature for high/low pressure monitor 1.		
Range:	Function:	
0 HplpResultUnit0*	[-999999.999 - 999999.999 HplpResultUnit0]	

30-40 Pressure Transmitter		
Select the analog input for high and low pressure/temperature monitoring.		
Option:	Function:	
[0] *	No function	
[1]	Analog Input 53	
[2]	Analog Input 54	
[7]	Analog Input X30/11	
[8]	Analog Input X30/12	
[9]	Analog Input X42/1	
[10]	Analog Input X42/3	
[11]	Analog Input X42/5	

30-41 Pressure Conversion		
Select how the frequency converter converts the signal from analog inputs.		
Option:	Function:	
[0] *	Linear	The output is proportional to the input.
[1]	Square root	Square root conversion is applied.

30-41 Pressure Conversion		
Select how the frequency converter converts the signal from analog inputs.		
Option:	Function:	
[2]	Pressure to temperature	The pressure is converted to temperature using refrigerant in <i>parameter 20-30 Refrigerant</i> and using temperature unit in <i>parameter 30-43 Temperature Unit</i> .

30-42 Pressure Source Unit		
Select the unit for pressure source monitoring.		
Option:	Function:	
[0]		
[1]	%	
[5]	PPM	
[10]	1/min	
[11]	RPM	
[12]	Pulse/s	
[20]	l/s	
[21]	l/min	
[22]	l/h	
[23]	m ³ /s	
[24]	m ³ /min	
[25]	m ³ /h	
[30]	kg/s	
[31]	kg/min	
[32]	kg/h	
[33]	t/min	
[34]	t/h	
[40]	m/s	
[41]	m/min	
[45]	m	
[60]	°C	
[70]	mbar	
[71] *	bar	
[72]	Pa	
[73]	kPa	
[74]	m WG	
[80]	kW	
[120]	GPM	
[121]	gal/s	
[122]	gal/min	
[123]	gal/h	
[124]	CFM	
[125]	ft ³ /s	
[126]	ft ³ /min	
[127]	ft ³ /h	
[130]	lb/s	
[131]	lb/min	
[132]	lb/h	
[140]	ft/s	
[141]	ft/min	
[145]	ft	

30-42 Pressure Source Unit		
Select the unit for pressure source monitoring.		
Option:	Function:	
[160]	°F	
[170]	psi	
[171]	lb/in ²	
[172]	in WG	
[173]	ft WG	
[180]	HP	

30-43 Temperature Unit		
Select the temperature unit for pressure to temperature conversion in <i>parameter 30-41 Pressure Conversion</i> .		
Option:	Function:	
[0]		
[1]	%	
[5]	PPM	
[10]	1/min	
[11]	RPM	
[12]	Pulse/s	
[20]	l/s	
[21]	l/min	
[22]	l/h	
[23]	m ³ /s	
[24]	m ³ /min	
[25]	m ³ /h	
[30]	kg/s	
[31]	kg/min	
[32]	kg/h	
[33]	t/min	
[34]	t/h	
[40]	m/s	
[41]	m/min	
[45]	m	
[60]	°C	
[70]	mbar	
[71]	bar	
[72]	Pa	
[73]	kPa	
[74]	m WG	
[80]	kW	
[120]	GPM	
[121]	gal/s	
[122]	gal/min	
[123]	gal/h	
[124]	CFM	
[125]	ft ³ /s	
[126]	ft ³ /min	
[127]	ft ³ /h	
[130]	lb/s	
[131]	lb/min	
[132]	lb/h	
[140]	ft/s	
[141]	ft/min	

30-43 Temperature Unit		
Select the temperature unit for pressure to temperature conversion in <i>parameter 30-41 Pressure Conversion</i> .		
Option:	Function:	
[145]	ft	
[160]	°F	
[170]	psi	
[171]	lb/in ²	
[172]	in WG	
[173]	ft WG	
[180]	HP	

30-44 High Pres. Stop		
If pressure or temperature exceeds the value of this parameter, pack is stopped.		
Range:	Function:	
999999.999 HplpResultUnit1*	[par. 30-46 - 999999.999 HplpResultUnit1]	

30-45 High Pres. Start		
If pressure or temperature is less than the value in this parameter and exceeds the value in <i>parameter 30-45 High Pres. Start</i> , the pack is started.		
Range:	Function:	
Size related*	[par. 30-47 - par. 30-44 HplpResultUnit1]	

30-46 Low Pres. Stop		
If pressure or temperature is lower than the value of this parameter value, pack is stopped.		
Range:	Function:	
-999999.999 HplpResultUnit1*	[-999999.999 - par. 30-44 HplpResultUnit1]	

30-47 Low Pres. Start		
If pressure or temperature is lower than the value in <i>parameter 30-46 Low Pres. Stop</i> and then exceeds the value in this parameter, pack is started.		
Range:	Function:	
Size related*	[par. 30-46 - par. 30-45 HplpResultUnit1]	

30-48 Pressure 2		
Shows the calculated pressure or temperature for high/low pressure monitor 2.		
Range:	Function:	
0 HplpResultUnit1*	[-999999.999 - 999999.999 HplpResultUnit1]	

30-49 Pressure Stop Ramp Time		
Enter the time allocated for ramping down, if pressure or temperature is outside thresholds configured in parameter groups <i>30-3* High/Low Pres. Stop 1</i> and <i>30-4* High/Low Pres. Stop 2</i> .		
Range:	Function:	
Size related*	[0 - 3600 s]	

30-50 Heat Sink Fan Mode		
Option:	Function:	
[0] Simple Profile	Select how the heat sink fan responds to operating conditions. The simple profile is a passive fan control based on the current temperature state of the frequency converter. This option represents the classic operating behavior of the fans.	

4 Parameter Lists

4.1 Parameter Options

4.1.1 Default Settings

Changes during operation

TRUE means that the parameter can be changed while the frequency converter is in operation. FALSE means that the frequency converter must be stopped before a change can be made.

4-set-up

All set-ups: The parameter can be set individually in each of the 4 set-ups, that is 1 single parameter can have 4 different data values.

1 set-up: Data value is the same in all set-ups.

N/A

No default value available.

Conversion index

This number refers to a conversion figure used when writing or reading via a frequency converter.

Conv. index	100	75	74	70	67	6	5	4	3	2	1	0	-1	-2	-3	-4	-5	-6
Conv. factor	1	3600000	3600	60	1/60	1000000	100000	10000	1000	100	10	1	0.1	0.01	0.001	0.0001	0.00001	0.000001

Table 4.1 Conversion Index

Data type	Description	Type
2	Integer 8	Int8
3	Integer 16	Int16
4	Integer 32	Int32
5	Unsigned 8	UInt8
6	Unsigned 16	UInt16
7	Unsigned 32	UInt32
9	Visible String	VisStr
33	Normalised value 2 bytes	N2
35	Bit sequence of 16 boolean variables	V2
54	Time difference w/o date	TimD

Table 4.2 Conversion Index Description

4.1.2 0-** Operation and Display

Parameter #	Parameter description	Default value	4 set-up	Change during operation	Conversion index	Type
0-0* Basic Settings						
0-01	Language	[0] English	1 set-up	TRUE	-	Uint8
0-02	Motor Speed Unit	[1] Hz	2 set-ups	FALSE	-	Uint8
0-03	Regional Settings	ExpressionLimit	2 set-ups	FALSE	-	Uint8
0-04	Operating State at Power-up	[0] Resume	All set-ups	TRUE	-	Uint8
0-05	Local Mode Unit	[0] As Motor Speed Unit	2 set-ups	FALSE	-	Uint8
0-1* Set-up Operations						
0-10	Active Set-up	[1] Set-up 1	1 set-up	TRUE	-	Uint8
0-11	Programming Set-up	[9] Active Set-up	All set-ups	TRUE	-	Uint8
0-12	This Set-up Linked to	[0] Not linked	All set-ups	FALSE	-	Uint8
0-13	Readout: Linked Set-ups	0 N/A	All set-ups	FALSE	0	Uint16
0-14	Readout: Prog. Set-ups / Channel	0 N/A	All set-ups	TRUE	0	Int32
0-2* LCP Display						
0-20	Display Line 1.1 Small	ExpressionLimit	All set-ups	TRUE	-	Uint16
0-21	Display Line 1.2 Small	ExpressionLimit	All set-ups	TRUE	-	Uint16
0-22	Display Line 1.3 Small	ExpressionLimit	All set-ups	TRUE	-	Uint16
0-23	Display Line 2 Large	ExpressionLimit	All set-ups	TRUE	-	Uint16
0-24	Display Line 3 Large	ExpressionLimit	All set-ups	TRUE	-	Uint16
0-25	My Personal Menu	ExpressionLimit	1 set-up	TRUE	0	Uint16
0-3* LCP Custom Readout						
0-30	Custom Readout Unit	[1] %	All set-ups	TRUE	-	Uint8
0-31	Custom Readout Min Value	ExpressionLimit	All set-ups	TRUE	-2	Int32
0-32	Custom Readout Max Value	100 CustomReadoutUnit	All set-ups	TRUE	-2	Int32
0-37	Display Text 1	0 N/A	1 set-up	TRUE	0	VisStr[25]
0-38	Display Text 2	0 N/A	1 set-up	TRUE	0	VisStr[25]
0-39	Display Text 3	0 N/A	1 set-up	TRUE	0	VisStr[25]
0-4* LCP Keypad						
0-40	[Hand on] Key on LCP	[1] Enabled	All set-ups	TRUE	-	Uint8
0-41	[Off] Key on LCP	[1] Enabled	All set-ups	TRUE	-	Uint8
0-42	[Auto on] Key on LCP	[1] Enabled	All set-ups	TRUE	-	Uint8
0-43	[Reset] Key on LCP	[1] Enabled	All set-ups	TRUE	-	Uint8
0-5* Copy/Save						
0-50	LCP Copy	[0] No copy	All set-ups	FALSE	-	Uint8
0-51	Set-up Copy	[0] No copy	All set-ups	FALSE	-	Uint8
0-6* Password						
0-60	Main Menu Password	100 N/A	1 set-up	TRUE	0	Int16
0-61	Access to Main Menu w/o Password	[0] Full access	1 set-up	TRUE	-	Uint8
0-65	Personal Menu Password	200 N/A	1 set-up	TRUE	0	Int16
0-66	Access to Personal Menu w/o Password	[0] Full access	1 set-up	TRUE	-	Uint8
0-67	Bus Password Access	0 N/A	All set-ups	TRUE	0	Uint16
0-7* Clock Settings						
0-70	Set Date and Time	ExpressionLimit	All set-ups	TRUE	0	TimeOfDay
0-71	Date Format	ExpressionLimit	1 set-up	TRUE	-	Uint8
0-72	Time Format	ExpressionLimit	1 set-up	TRUE	-	Uint8
0-74	DST/Summertime	[0] Off	1 set-up	TRUE	-	Uint8
0-76	DST/Summertime Start	ExpressionLimit	1 set-up	TRUE	0	TimeOfDay
0-77	DST/Summertime End	ExpressionLimit	1 set-up	TRUE	0	TimeOfDay

Parameter #	Parameter description	Default value	4 set-up	Change during operation	Conversion index	Type
0-79	Clock Fault	[0] Disabled	1 set-up	TRUE	-	UInt8
0-81	Working Days	ExpressionLimit	1 set-up	TRUE	-	UInt8
0-82	Additional Working Days	ExpressionLimit	1 set-up	TRUE	0	TimeOfDay
0-83	Additional Non-Working Days	ExpressionLimit	1 set-up	TRUE	0	TimeOfDay
0-89	Date and Time Readout	0 N/A	All set-ups	TRUE	0	VisStr[25]

4

4.1.3 1-** Load/Motor

Parameter #	Parameter description	Default value	4 set-up	Change during operation	Conversion index	Type
1-0* General Settings						
1-00	Configuration Mode	ExpressionLimit	All set-ups	TRUE	-	UInt8
1-03	Torque Characteristics	[0] Compressor CT	All set-ups	TRUE	-	UInt8
1-06	Clockwise Direction	[0] Normal	All set-ups	FALSE	-	UInt8
1-1* Motor Selection						
1-10	Motor Construction	[0] Asynchron	All set-ups	FALSE	-	UInt8
1-1* VVC+ PM/SYN RM						
1-14	Damping Gain	120 %	All set-ups	TRUE	0	Int16
1-15	Low Speed Filter Time Const.	ExpressionLimit	All set-ups	TRUE	-2	UInt16
1-16	High Speed Filter Time Const.	ExpressionLimit	All set-ups	TRUE	-2	UInt16
1-17	Voltage filter time const.	ExpressionLimit	All set-ups	TRUE	-3	UInt16
1-2* Motor Data						
1-20	Motor Power [kW]	ExpressionLimit	All set-ups	FALSE	1	UInt32
1-21	Motor Power [HP]	ExpressionLimit	All set-ups	FALSE	-2	UInt32
1-22	Motor Voltage	ExpressionLimit	All set-ups	FALSE	0	UInt16
1-23	Motor Frequency	ExpressionLimit	All set-ups	FALSE	0	UInt16
1-24	Motor Current	ExpressionLimit	All set-ups	FALSE	-2	UInt32
1-25	Motor Nominal Speed	ExpressionLimit	All set-ups	FALSE	67	UInt16
1-26	Motor Cont. Rated Torque	ExpressionLimit	All set-ups	FALSE	-1	UInt32
1-28	Motor Rotation Check	[0] Off	All set-ups	FALSE	-	UInt8
1-29	Automatic Motor Adaptation (AMA)	[0] Off	All set-ups	FALSE	-	UInt8
1-3* Adv. Motor Data						
1-30	Stator Resistance (Rs)	ExpressionLimit	All set-ups	FALSE	-4	UInt32
1-31	Rotor Resistance (Rr)	ExpressionLimit	All set-ups	FALSE	-4	UInt32
1-35	Main Reactance (Xh)	ExpressionLimit	All set-ups	FALSE	-4	UInt32
1-36	Iron Loss Resistance (Rfe)	ExpressionLimit	All set-ups	FALSE	-3	UInt32
1-37	d-axis Inductance (Ld)	ExpressionLimit	All set-ups	FALSE	-6	Int32
1-38	q-axis Inductance (Lq)	ExpressionLimit	All set-ups	FALSE	-6	Int32
1-39	Motor Poles	ExpressionLimit	All set-ups	FALSE	0	UInt8
1-40	Back EMF at 1000 RPM	ExpressionLimit	All set-ups	FALSE	0	UInt16
1-41	Motor Angle Offset	0 N/A	All set-ups	FALSE	0	Int16
1-44	d-axis Inductance Sat. (LdSat)	ExpressionLimit	All set-ups	FALSE	-6	Int32
1-45	q-axis Inductance Sat. (LqSat)	ExpressionLimit	All set-ups	FALSE	-6	Int32
1-46	Position Detection Gain	100 %	All set-ups	TRUE	0	UInt16
1-47	Torque Calibration	ExpressionLimit	All set-ups	TRUE	-	UInt8
1-48	Inductance Sat. Point	ExpressionLimit	All set-ups	TRUE	0	Int16
1-5* Load Indep. Setting						
1-50	Motor Magnetisation at Zero Speed	100 %	All set-ups	TRUE	0	UInt16
1-51	Min Speed Normal Magnetising [RPM]	ExpressionLimit	All set-ups	TRUE	67	UInt16
1-52	Min Speed Normal Magnetising [Hz]	ExpressionLimit	All set-ups	TRUE	-1	UInt16
1-58	Flying Start Test Pulses Current	ExpressionLimit	All set-ups	FALSE	0	UInt16

Parameter #	Parameter description	Default value	4 set-up	Change during operation	Conversion index	Type
1-59	Flying Start Test Pulses Frequency	ExpressionLimit	All set-ups	FALSE	0	Uint16
1-6* Load Depen. Setting						
1-60	Low Speed Load Compensation	100 %	All set-ups	TRUE	0	Int16
1-61	High Speed Load Compensation	100 %	All set-ups	TRUE	0	Int16
1-62	Slip Compensation	0 %	All set-ups	TRUE	0	Int16
1-63	Slip Compensation Time Constant	ExpressionLimit	All set-ups	TRUE	-2	Uint16
1-64	Resonance Dampening	100 %	All set-ups	TRUE	0	Uint16
1-65	Resonance Dampening Time Constant	5 ms	All set-ups	TRUE	-3	Uint8
1-66	Min. Current at Low Speed	ExpressionLimit	All set-ups	TRUE	0	Uint8
1-7* Start Adjustments						
1-70	PM Start Mode	[1] Parking	All set-ups	TRUE	-	Uint8
1-71	Start Delay	00 s	All set-ups	TRUE	-1	Uint16
1-72	Start Function	ExpressionLimit	All set-ups	TRUE	-	Uint8
1-73	Flying Start	ExpressionLimit	All set-ups	FALSE	-	Uint8
1-74	Start Speed [RPM]	ExpressionLimit	All set-ups	TRUE	67	Uint16
1-75	Start Speed [Hz]	ExpressionLimit	All set-ups	TRUE	-1	Uint16
1-76	Start Current	0 A	All set-ups	TRUE	-2	Uint32
1-77	Compressor Start Max Speed [RPM]	ExpressionLimit	All set-ups	TRUE	67	Uint16
1-78	Compressor Start Max Speed [Hz]	ExpressionLimit	All set-ups	TRUE	-1	Uint16
1-79	Compressor Start Max Time to Trip	5 s	All set-ups	TRUE	-1	Uint8
1-8* Stop Adjustments						
1-80	Function at Stop	[0] Coast	All set-ups	TRUE	-	Uint8
1-81	Min Speed for Function at Stop [RPM]	ExpressionLimit	All set-ups	TRUE	67	Uint16
1-82	Min Speed for Function at Stop [Hz]	ExpressionLimit	All set-ups	TRUE	-1	Uint16
1-86	Compressor Min. Speed for Trip [RPM]	ExpressionLimit	All set-ups	TRUE	67	Uint16
1-87	Compressor Min. Speed for Trip [Hz]	ExpressionLimit	All set-ups	TRUE	-1	Uint16
1-9* Motor Temperature						
1-90	Motor Thermal Protection	ExpressionLimit	All set-ups	TRUE	-	Uint8
1-91	Motor External Fan	[0] No	All set-ups	TRUE	-	Uint8
1-93	Thermistor Source	[0] None	All set-ups	TRUE	-	Uint8

4.1.4 2-** Brakes

Parameter #	Parameter description	Default value	4 set-up	Change during operation	Conversion index	Type
2-0* DC-Brake						
2-00	DC Hold/Preheat Current	50 %	All set-ups	TRUE	0	Uint8
2-01	DC Brake Current	50 %	All set-ups	TRUE	0	Uint16
2-02	DC Braking Time	10 s	All set-ups	TRUE	-1	Uint16
2-03	DC Brake Cut In Speed [RPM]	ExpressionLimit	All set-ups	TRUE	67	Uint16
2-04	DC Brake Cut In Speed [Hz]	ExpressionLimit	All set-ups	TRUE	-1	Uint16
2-06	Parking Current	50 %	All set-ups	TRUE	0	Uint16
2-07	Parking Time	3 s	All set-ups	TRUE	-1	Uint16
2-1* Brake Energy Funct.						
2-10	Brake Function	ExpressionLimit	All set-ups	TRUE	-	Uint8
2-16	AC brake Max. Current	100 %	All set-ups	TRUE	-1	Uint32
2-17	Over-voltage Control	[2] Enabled	All set-ups	TRUE	-	Uint8

4.1.5 3-** Reference/Ramps

4

Parameter #	Parameter description	Default value	4 set-up	Change during operation	Conversion index	Type
3-0* Reference Limits						
3-02	Minimum Reference	ExpressionLimit	All set-ups	TRUE	-3	Int32
3-03	Maximum Reference	ExpressionLimit	All set-ups	TRUE	-3	Int32
3-04	Reference Function	[0] Sum	All set-ups	TRUE	-	UInt8
3-1* References						
3-10	Preset Reference	0 %	All set-ups	TRUE	-2	Int16
3-11	Jog Speed [Hz]	ExpressionLimit	All set-ups	TRUE	-1	UInt16
3-13	Reference Site	[0] Linked to Hand / Auto	All set-ups	TRUE	-	UInt8
3-14	Preset Relative Reference	0 %	All set-ups	TRUE	-2	Int32
3-15	Reference 1 Source	[1] Analog Input 53	All set-ups	TRUE	-	UInt8
3-16	Reference 2 Source	[20] Digital pot.meter	All set-ups	TRUE	-	UInt8
3-17	Reference 3 Source	[0] No function	All set-ups	TRUE	-	UInt8
3-19	Jog Speed [RPM]	ExpressionLimit	All set-ups	TRUE	67	UInt16
3-4* Ramp 1						
3-41	Ramp 1 Ramp Up Time	ExpressionLimit	All set-ups	TRUE	-2	UInt32
3-42	Ramp 1 Ramp Down Time	ExpressionLimit	All set-ups	TRUE	-2	UInt32
3-5* Ramp 2						
3-51	Ramp 2 Ramp Up Time	ExpressionLimit	All set-ups	TRUE	-2	UInt32
3-52	Ramp 2 Ramp Down Time	ExpressionLimit	All set-ups	TRUE	-2	UInt32
3-8* Other Ramps						
3-80	Jog Ramp Time	ExpressionLimit	All set-ups	TRUE	-2	UInt32
3-81	Quick Stop Ramp Time	ExpressionLimit	2 set-ups	TRUE	-2	UInt32
3-82	Starting Ramp Up Time	ExpressionLimit	2 set-ups	TRUE	-2	UInt32
3-9* Digital Pot.Meter						
3-90	Step Size	0.10 %	All set-ups	TRUE	-2	UInt16
3-91	Ramp Time	1 s	All set-ups	TRUE	-2	UInt32
3-92	Power Restore	[0] Off	All set-ups	TRUE	-	UInt8
3-93	Maximum Limit	100 %	All set-ups	TRUE	0	Int16
3-94	Minimum Limit	0 %	All set-ups	TRUE	0	Int16
3-95	Ramp Delay	1 N/A	All set-ups	TRUE	-3	TimD

4.1.6 4-** Limits/Warnings

Parameter #	Parameter description	Default value	4 set-up	Change during operation	Conversion index	Type
4-1* Motor Limits						
4-10	Motor Speed Direction	[0] Clockwise	All set-ups	FALSE	-	Uint8
4-11	Motor Speed Low Limit [RPM]	ExpressionLimit	All set-ups	TRUE	67	Uint16
4-12	Motor Speed Low Limit [Hz]	ExpressionLimit	All set-ups	TRUE	-1	Uint16
4-13	Motor Speed High Limit [RPM]	ExpressionLimit	All set-ups	TRUE	67	Uint16
4-14	Motor Speed High Limit [Hz]	ExpressionLimit	All set-ups	TRUE	-1	Uint16
4-16	Torque Limit Motor Mode	110 %	All set-ups	TRUE	-1	Uint16
4-17	Torque Limit Generator Mode	100 %	All set-ups	TRUE	-1	Uint16
4-18	Current Limit	ExpressionLimit	All set-ups	TRUE	-1	Uint32
4-19	Max Output Frequency	ExpressionLimit	All set-ups	FALSE	-1	Uint16
4-5* Adj. Warnings						
4-50	Warning Current Low	0 A	All set-ups	TRUE	-2	Uint32
4-51	Warning Current High	I _{max} VLT (P1637)	All set-ups	TRUE	-2	Uint32
4-52	Warning Speed Low	0 RPM	All set-ups	TRUE	67	Uint16
4-53	Warning Speed High	ExpressionLimit	All set-ups	TRUE	67	Uint16
4-54	Warning Reference Low	-999999 N/A	All set-ups	TRUE	-3	Int32
4-55	Warning Reference High	999999 N/A	All set-ups	TRUE	-3	Int32
4-56	Warning Feedback Low	-999999 Reference-FeedbackUnit	All set-ups	TRUE	-3	Int32
4-57	Warning Feedback High	999999 Reference-FeedbackUnit	All set-ups	TRUE	-3	Int32
4-58	Missing Motor Phase Function	ExpressionLimit	All set-ups	TRUE	-	Uint8
4-59	Motor Check At Start	[0] Off	All set-ups	TRUE	-	Uint8
4-6* Speed Bypass						
4-60	Bypass Speed From [RPM]	ExpressionLimit	All set-ups	TRUE	67	Uint16
4-61	Bypass Speed From [Hz]	ExpressionLimit	All set-ups	TRUE	-1	Uint16
4-62	Bypass Speed To [RPM]	ExpressionLimit	All set-ups	TRUE	67	Uint16
4-63	Bypass Speed To [Hz]	ExpressionLimit	All set-ups	TRUE	-1	Uint16
4-64	Semi-Auto Bypass Set-up	[0] Off	All set-ups	FALSE	-	Uint8

4.1.7 5-** Digital In/Out

Parameter #	Parameter description	Default value	4 set-up	Change during operation	Conversion index	Type
5-0* Digital I/O mode						
5-00	Digital I/O Mode	[0] PNP - Active at 24V	All set-ups	FALSE	-	Uint8
5-01	Terminal 27 Mode	[0] Input	All set-ups	TRUE	-	Uint8
5-02	Terminal 29 Mode	[0] Input	All set-ups	TRUE	-	Uint8
5-1* Digital Inputs						
5-10	Terminal 18 Digital Input	ExpressionLimit	All set-ups	TRUE	-	Uint8
5-11	Terminal 19 Digital Input	ExpressionLimit	All set-ups	TRUE	-	Uint8
5-12	Terminal 27 Digital Input	ExpressionLimit	All set-ups	TRUE	-	Uint8
5-13	Terminal 29 Digital Input	ExpressionLimit	All set-ups	TRUE	-	Uint8
5-14	Terminal 32 Digital Input	ExpressionLimit	All set-ups	TRUE	-	Uint8
5-15	Terminal 33 Digital Input	ExpressionLimit	All set-ups	TRUE	-	Uint8
5-16	Terminal X30/2 Digital Input	ExpressionLimit	All set-ups	TRUE	-	Uint8
5-17	Terminal X30/3 Digital Input	ExpressionLimit	All set-ups	TRUE	-	Uint8
5-18	Terminal X30/4 Digital Input	ExpressionLimit	All set-ups	TRUE	-	Uint8
5-19	Terminal 37 Safe Stop	ExpressionLimit	1 set-up	TRUE	-	Uint8

Parameter #	Parameter description	Default value	4 set-up	Change during operation	Conversion index	Type
5-20	Terminal X46/1 Digital Input	ExpressionLimit	All set-ups	TRUE	-	Uint8
5-21	Terminal X46/3 Digital Input	ExpressionLimit	All set-ups	TRUE	-	Uint8
5-22	Terminal X46/5 Digital Input	ExpressionLimit	All set-ups	TRUE	-	Uint8
5-23	Terminal X46/7 Digital Input	ExpressionLimit	All set-ups	TRUE	-	Uint8
5-24	Terminal X46/9 Digital Input	ExpressionLimit	All set-ups	TRUE	-	Uint8
5-25	Terminal X46/11 Digital Input	ExpressionLimit	All set-ups	TRUE	-	Uint8
5-26	Terminal X46/13 Digital Input	ExpressionLimit	All set-ups	TRUE	-	Uint8
5-3* Digital Outputs						
5-30	Terminal 27 Digital Output	[0] No operation	All set-ups	TRUE	-	Uint8
5-31	Terminal 29 Digital Output	[0] No operation	All set-ups	TRUE	-	Uint8
5-32	Term X30/6 Digi Out (MCB 101)	[0] No operation	All set-ups	TRUE	-	Uint8
5-33	Term X30/7 Digi Out (MCB 101)	[0] No operation	All set-ups	TRUE	-	Uint8
5-4* Relays						
5-40	Function Relay	ExpressionLimit	All set-ups	TRUE	-	Uint8
5-41	On Delay, Relay	0.01 s	All set-ups	TRUE	-2	Uint16
5-42	Off Delay, Relay	0.01 s	All set-ups	TRUE	-2	Uint16
5-5* Pulse Input						
5-50	Term. 29 Low Frequency	100 Hz	All set-ups	TRUE	0	Uint32
5-51	Term. 29 High Frequency	100 Hz	All set-ups	TRUE	0	Uint32
5-52	Term. 29 Low Ref./Feedb. Value	0 N/A	All set-ups	TRUE	-3	Int32
5-53	Term. 29 High Ref./Feedb. Value	100 N/A	All set-ups	TRUE	-3	Int32
5-54	Pulse Filter Time Constant #29	100 ms	All set-ups	FALSE	-3	Uint16
5-55	Term. 33 Low Frequency	100 Hz	All set-ups	TRUE	0	Uint32
5-56	Term. 33 High Frequency	100 Hz	All set-ups	TRUE	0	Uint32
5-57	Term. 33 Low Ref./Feedb. Value	0 N/A	All set-ups	TRUE	-3	Int32
5-58	Term. 33 High Ref./Feedb. Value	100 N/A	All set-ups	TRUE	-3	Int32
5-59	Pulse Filter Time Constant #33	100 ms	All set-ups	FALSE	-3	Uint16
5-6* Pulse Output						
5-60	Terminal 27 Pulse Output Variable	[0] No operation	All set-ups	TRUE	-	Uint8
5-62	Pulse Output Max Freq #27	5000 Hz	All set-ups	TRUE	0	Uint32
5-63	Terminal 29 Pulse Output Variable	[0] No operation	All set-ups	TRUE	-	Uint8
5-65	Pulse Output Max Freq #29	5000 Hz	All set-ups	TRUE	0	Uint32
5-66	Terminal X30/6 Pulse Output Variable	[0] No operation	All set-ups	TRUE	-	Uint8
5-68	Pulse Output Max Freq #X30/6	5000 Hz	All set-ups	TRUE	0	Uint32
5-8* I/O Options						
5-80	AHF Cap Reconnect Delay	25 s	2 set-ups	TRUE	0	Uint16
5-9* Bus Controlled						
5-90	Digital & Relay Bus Control	0 N/A	All set-ups	TRUE	0	Uint32
5-93	Pulse Out #27 Bus Control	0 %	All set-ups	TRUE	-2	N2
5-94	Pulse Out #27 Timeout Preset	0 %	1 set-up	TRUE	-2	Uint16
5-95	Pulse Out #29 Bus Control	0 %	All set-ups	TRUE	-2	N2
5-96	Pulse Out #29 Timeout Preset	0 %	1 set-up	TRUE	-2	Uint16
5-97	Pulse Out #X30/6 Bus Control	0 %	All set-ups	TRUE	-2	N2
5-98	Pulse Out #X30/6 Timeout Preset	0 %	1 set-up	TRUE	-2	Uint16

4.1.8 6-** Analog In/Out

Parameter #	Parameter description	Default value	4 set-up	Change during operation	Conversion index	Type
6-0* Analog I/O Mode						
6-00	Live Zero Timeout Time	10 s	All set-ups	TRUE	0	Uint8
6-01	Live Zero Timeout Function	[0] Off	All set-ups	TRUE	-	Uint8
6-1* Analog Input 53						
6-10	Terminal 53 Low Voltage	0.07 V	All set-ups	TRUE	-2	Int16
6-11	Terminal 53 High Voltage	10 V	All set-ups	TRUE	-2	Int16
6-12	Terminal 53 Low Current	4 mA	All set-ups	TRUE	-5	Int16
6-13	Terminal 53 High Current	20 mA	All set-ups	TRUE	-5	Int16
6-14	Terminal 53 Low Ref./Feedb. Value	0 N/A	All set-ups	TRUE	-3	Int32
6-15	Terminal 53 High Ref./Feedb. Value	ExpressionLimit	All set-ups	TRUE	-3	Int32
6-16	Terminal 53 Filter Time Constant	0.001 s	All set-ups	TRUE	-3	Uint16
6-17	Terminal 53 Live Zero	[1] Enabled	All set-ups	TRUE	-	Uint8
6-2* Analog Input 54						
6-20	Terminal 54 Low Voltage	0.07 V	All set-ups	TRUE	-2	Int16
6-21	Terminal 54 High Voltage	10 V	All set-ups	TRUE	-2	Int16
6-22	Terminal 54 Low Current	4 mA	All set-ups	TRUE	-5	Int16
6-23	Terminal 54 High Current	20 mA	All set-ups	TRUE	-5	Int16
6-24	Terminal 54 Low Ref./Feedb. Value	-1 N/A	All set-ups	TRUE	-3	Int32
6-25	Terminal 54 High Ref./Feedb. Value	ExpressionLimit	All set-ups	TRUE	-3	Int32
6-26	Terminal 54 Filter Time Constant	0.001 s	All set-ups	TRUE	-3	Uint16
6-27	Terminal 54 Live Zero	[1] Enabled	All set-ups	TRUE	-	Uint8
6-3* Analog Input X30/11						
6-30	Terminal X30/11 Low Voltage	0.07 V	All set-ups	TRUE	-2	Int16
6-31	Terminal X30/11 High Voltage	10 V	All set-ups	TRUE	-2	Int16
6-34	Term. X30/11 Low Ref./Feedb. Value	0 N/A	All set-ups	TRUE	-3	Int32
6-35	Term. X30/11 High Ref./Feedb. Value	100 N/A	All set-ups	TRUE	-3	Int32
6-36	Term. X30/11 Filter Time Constant	0.001 s	All set-ups	TRUE	-3	Uint16
6-37	Term. X30/11 Live Zero	[1] Enabled	All set-ups	TRUE	-	Uint8
6-4* Analog Input X30/12						
6-40	Terminal X30/12 Low Voltage	0.07 V	All set-ups	TRUE	-2	Int16
6-41	Terminal X30/12 High Voltage	10 V	All set-ups	TRUE	-2	Int16
6-44	Term. X30/12 Low Ref./Feedb. Value	0 N/A	All set-ups	TRUE	-3	Int32
6-45	Term. X30/12 High Ref./Feedb. Value	100 N/A	All set-ups	TRUE	-3	Int32
6-46	Term. X30/12 Filter Time Constant	0.001 s	All set-ups	TRUE	-3	Uint16
6-47	Term. X30/12 Live Zero	[1] Enabled	All set-ups	TRUE	-	Uint8
6-5* Analog Output 42						
6-50	Terminal 42 Output	[100] Output frequency	All set-ups	TRUE	-	Uint8
6-51	Terminal 42 Output Min Scale	0 %	All set-ups	TRUE	-2	Int16
6-52	Terminal 42 Output Max Scale	100 %	All set-ups	TRUE	-2	Int16
6-53	Terminal 42 Output Bus Control	0 %	All set-ups	TRUE	-2	N2
6-54	Terminal 42 Output Timeout Preset	0 %	1 set-up	TRUE	-2	Uint16
6-6* Analog Output X30/8						
6-60	Terminal X30/8 Output	[0] No operation	All set-ups	TRUE	-	Uint8
6-61	Terminal X30/8 Min. Scale	0 %	All set-ups	TRUE	-2	Int16
6-62	Terminal X30/8 Max. Scale	100 %	All set-ups	TRUE	-2	Int16
6-63	Terminal X30/8 Output Bus Control	0 %	All set-ups	TRUE	-2	N2
6-64	Terminal X30/8 Output Timeout Preset	0 %	1 set-up	TRUE	-2	Uint16
6-7* Analog Output X45/1						

Parameter #	Parameter description	Default value	4 set-up	Change during operation	Conversion index	Type
6-70	Terminal X45/1 Output	[0] No operation	All set-ups	TRUE	-	Uint8
6-71	Terminal X45/1 Min. Scale	0 %	All set-ups	TRUE	-2	Int16
6-72	Terminal X45/1 Max. Scale	100 %	All set-ups	TRUE	-2	Int16
6-73	Terminal X45/1 Bus Control	0 %	All set-ups	TRUE	-2	N2
6-74	Terminal X45/1 Output Timeout Preset	0 %	1 set-up	TRUE	-2	Uint16
6-8* Analog Output X45/3						
6-80	Terminal X45/3 Output	[0] No operation	All set-ups	TRUE	-	Uint8
6-81	Terminal X45/3 Min. Scale	0 %	All set-ups	TRUE	-2	Int16
6-82	Terminal X45/3 Max. Scale	100 %	All set-ups	TRUE	-2	Int16
6-83	Terminal X45/3 Bus Control	0 %	All set-ups	TRUE	-2	N2
6-84	Terminal X45/3 Output Timeout Preset	0 %	1 set-up	TRUE	-2	Uint16

4.1.9 8-** Communication and Options

Parameter #	Parameter description	Default value	4 set-up	Change during operation	Conversion index	Type
8-0* General Settings						
8-01	Control Site	[0] Digital and ctrl.word	All set-ups	TRUE	-	Uint8
8-02	Control Source	ExpressionLimit	All set-ups	TRUE	-	Uint8
8-03	Control Timeout Time	ExpressionLimit	1 set-up	TRUE	-1	Uint32
8-04	Control Timeout Function	[0] Off	1 set-up	TRUE	-	Uint8
8-05	End-of-Timeout Function	[1] Resume set-up	1 set-up	TRUE	-	Uint8
8-06	Reset Control Timeout	[0] Do not reset	All set-ups	TRUE	-	Uint8
8-07	Diagnosis Trigger	[0] Disable	2 set-ups	TRUE	-	Uint8
8-1* Control Settings						
8-10	Control Profile	[0] FC profile	All set-ups	TRUE	-	Uint8
8-13	Configurable Status Word STW	[1] Profile Default	All set-ups	TRUE	-	Uint8
8-16	Store Data Values	[0] Off	All set-ups	TRUE	-	Uint8
8-3* FC Port Settings						
8-30	Protocol	[0] FC	1 set-up	TRUE	-	Uint8
8-31	Address	ExpressionLimit	1 set-up	TRUE	0	Uint8
8-32	Baud Rate	ExpressionLimit	1 set-up	TRUE	-	Uint8
8-33	Parity / Stop Bits	ExpressionLimit	1 set-up	TRUE	-	Uint8
8-35	Minimum Response Delay	10 ms	1 set-up	TRUE	-3	Uint16
8-36	Maximum Response Delay	ExpressionLimit	1 set-up	TRUE	-3	Uint16
8-37	Maximum Inter-Char Delay	ExpressionLimit	1 set-up	TRUE	-5	Uint16
8-4* Adv. Protocol Set.						
8-40	Telegram Selection	[1] Standard telegram 1	2 set-ups	TRUE	-	Uint8
8-42	PCD Write Configuration	ExpressionLimit	2 set-ups	TRUE	-	Uint16
8-43	PCD Read Configuration	ExpressionLimit	2 set-ups	TRUE	-	Uint16
8-45	BTM Transaction Command	[0] Off	All set-ups	FALSE	-	Uint8
8-46	BTM Transaction Status	[0] Off	All set-ups	TRUE	-	Uint8
8-47	BTM Timeout	60 s	1 set-up	FALSE	0	Uint16
8-5* Digital/Bus						
8-50	Coasting Select	[3] Logic OR	All set-ups	TRUE	-	Uint8
8-52	DC Brake Select	ExpressionLimit	All set-ups	TRUE	-	Uint8
8-53	Start Select	[3] Logic OR	All set-ups	TRUE	-	Uint8
8-54	Reversing Select	[0] Digital input	All set-ups	TRUE	-	Uint8

Parameter #	Parameter description	Default value	4 set-up	Change during operation	Conversion index	Type
8-55	Set-up Select	[3] Logic OR	All set-ups	TRUE	-	Uint8
8-56	Preset Reference Select	[3] Logic OR	All set-ups	TRUE	-	Uint8
8-8* FC Port Diagnostics						
8-80	Bus Message Count	0 N/A	All set-ups	TRUE	0	Uint32
8-81	Bus Error Count	0 N/A	All set-ups	TRUE	0	Uint32
8-82	Slave Message Count	0 N/A	All set-ups	TRUE	0	Uint32
8-83	Slave Error Count	0 N/A	All set-ups	TRUE	0	Uint32
8-9* Bus Jog / Feedback						
8-90	Bus Jog 1 Speed	100 RPM	All set-ups	TRUE	67	Uint16
8-91	Bus Jog 2 Speed	ExpressionLimit	All set-ups	TRUE	67	Uint16
8-94	Bus Feedback 1	0 N/A	1 set-up	TRUE	0	N2
8-95	Bus Feedback 2	0 N/A	1 set-up	TRUE	0	N2
8-96	Bus Feedback 3	0 N/A	1 set-up	TRUE	0	N2

4.1.10 11-** FC 103 LON

Parameter #	Parameter description	Default value	4 set-up	Change during operation	Conversion index	Type
11-2* LON Param. Access						
11-21	Store Data Values	[0] Off	All set-ups	TRUE	-	Uint8
11-9* AK LonWorks						
11-90	VLT Network Address	0 N/A	1 set-up	TRUE	0	Uint16
11-91	AK Service Pin	[0] Off	1 set-up	TRUE	-	Uint8
11-98	Alarm Text	0 N/A	All set-ups	FALSE	0	VisStr[32]
11-99	Alarm Status	0 N/A	All set-ups	FALSE	0	Uint8

4.1.11 13-** Smart Logic Controller

Parameter #	Parameter description	Default value	4 set-up	Change during operation	Conversion index	Type
13-0* SLC Settings						
13-00	SL Controller Mode	ExpressionLimit	2 set-ups	TRUE	-	Uint8
13-01	Start Event	ExpressionLimit	2 set-ups	TRUE	-	Uint8
13-02	Stop Event	ExpressionLimit	2 set-ups	TRUE	-	Uint8
13-03	Reset SLC	[0] Do not reset SLC	All set-ups	TRUE	-	Uint8
13-1* Comparators						
13-10	Comparator Operand	ExpressionLimit	2 set-ups	TRUE	-	Uint8
13-11	Comparator Operator	ExpressionLimit	2 set-ups	TRUE	-	Uint8
13-12	Comparator Value	ExpressionLimit	2 set-ups	TRUE	-3	Int32
13-2* Timers						
13-20	SL Controller Timer	ExpressionLimit	1 set-up	TRUE	-3	TimD
13-4* Logic Rules						
13-40	Logic Rule Boolean 1	ExpressionLimit	2 set-ups	TRUE	-	Uint8
13-41	Logic Rule Operator 1	ExpressionLimit	2 set-ups	TRUE	-	Uint8
13-42	Logic Rule Boolean 2	ExpressionLimit	2 set-ups	TRUE	-	Uint8
13-43	Logic Rule Operator 2	ExpressionLimit	2 set-ups	TRUE	-	Uint8
13-44	Logic Rule Boolean 3	ExpressionLimit	2 set-ups	TRUE	-	Uint8
13-5* States						
13-51	SL Controller Event	ExpressionLimit	2 set-ups	TRUE	-	Uint8
13-52	SL Controller Action	ExpressionLimit	2 set-ups	TRUE	-	Uint8

Parameter #	Parameter description	Default value	4 set-up	Change during operation	Conversion index	Type
13-9* User Defined Alerts						
13-90	Alert Trigger	[0] False	2 set-ups	TRUE	-	UInt8
13-91	Alert Action	[0] Info	2 set-ups	TRUE	-	UInt8
13-92	Alert Text	ExpressionLimit	2 set-ups	TRUE	0	VisStr[20]
13-9* User Defined Readouts						
13-97	Alert Alarm Word	0 N/A	All set-ups	FALSE	0	UInt32
13-98	Alert Warning Word	0 N/A	All set-ups	FALSE	0	UInt32
13-99	Alert Status Word	0 N/A	All set-ups	FALSE	0	UInt32

4.1.12 14-** Special Functions

Parameter #	Parameter description	Default value	4 set-up	Change during operation	Conversion index	Type
14-0* Inverter Switching						
14-00	Switching Pattern	[0] 60 AVM	All set-ups	TRUE	-	UInt8
14-01	Switching Frequency	ExpressionLimit	All set-ups	TRUE	-	UInt8
14-03	Overmodulation	[1] On	All set-ups	FALSE	-	UInt8
14-04	PWM Random	[0] Off	All set-ups	TRUE	-	UInt8
14-1* Mains On/Off						
14-10	Mains Failure	[0] No function	All set-ups	FALSE	-	UInt8
14-11	Mains Voltage at Mains Fault	ExpressionLimit	All set-ups	TRUE	0	UInt16
14-12	Function at Mains Imbalance	[0] Trip	All set-ups	TRUE	-	UInt8
14-16	Kin. Backup Gain	100 %	All set-ups	TRUE	0	UInt32
14-2* Reset Functions						
14-20	Reset Mode	[3] Automatic reset x 3	All set-ups	TRUE	-	UInt8
14-21	Automatic Restart Time	60 s	All set-ups	TRUE	0	UInt16
14-22	Operation Mode	[0] Normal operation	All set-ups	TRUE	-	UInt8
14-25	Trip Delay at Torque Limit	60 s	All set-ups	TRUE	0	UInt8
14-26	Trip Delay at Inverter Fault	ExpressionLimit	All set-ups	TRUE	0	UInt8
14-28	Production Settings	[0] No action	All set-ups	TRUE	-	UInt8
14-29	Service Code	0 N/A	All set-ups	TRUE	0	Int32
14-3* Current Limit Ctrl.						
14-30	Current Lim Ctrl, Proportional Gain	100 %	All set-ups	FALSE	0	UInt16
14-31	Current Lim Ctrl, Integration Time	ExpressionLimit	All set-ups	FALSE	-3	UInt16
14-4* Energy Optimising						
14-40	VT Level	66 %	All set-ups	FALSE	0	UInt8
14-41	AEO Minimum Magnetisation	ExpressionLimit	All set-ups	TRUE	0	UInt8
14-42	Minimum AEO Frequency	ExpressionLimit	All set-ups	TRUE	0	UInt8
14-43	Motor Cosphi	ExpressionLimit	All set-ups	TRUE	-2	UInt16
14-5* Environment						
14-50	RFI Filter	[1] On	1 set-up	FALSE	-	UInt8
14-51	DC Link Compensation	ExpressionLimit	All set-ups	TRUE	-	UInt8
14-52	Fan Control	[0] Auto	All set-ups	TRUE	-	UInt8
14-53	Fan Monitor	[1] Warning	All set-ups	TRUE	-	UInt8
14-55	Output Filter	[0] No Filter	1 set-up	FALSE	-	UInt8
14-59	Actual Number of Inverter Units	ExpressionLimit	1 set-up	FALSE	0	UInt8
14-6* Auto Derate						
14-60	Function at Over Temperature	[0] Trip	All set-ups	TRUE	-	UInt8
14-61	Function at Inverter Overload	[0] Trip	All set-ups	TRUE	-	UInt8
14-62	Inv. Overload Derate Current	95 %	All set-ups	TRUE	0	UInt16

Parameter #	Parameter description	Default value	4 set-up	Change during operation	Conversion index	Type
14-8* Options						
14-80	Option Supplied by External 24VDC	[1] Yes	2 set-ups	FALSE	-	UInt8
14-89	Option Detection	[0] Protect Option Config.	1 set-up	TRUE	-	UInt8
14-9* Fault Settings						
14-90	Fault Level	ExpressionLimit	1 set-up	TRUE	-	UInt8

4.1.13 15-** FC Information

Parameter #	Parameter description	Default value	4 set-up	Change during operation	Conversion index	Type
15-0* Operating Data						
15-00	Operating hours	0 h	All set-ups	FALSE	74	UInt32
15-01	Running Hours	0 h	All set-ups	FALSE	74	UInt32
15-02	kWh Counter	0 kWh	All set-ups	FALSE	75	UInt32
15-03	Power Up's	0 N/A	All set-ups	FALSE	0	UInt32
15-04	Over Temp's	0 N/A	All set-ups	FALSE	0	UInt16
15-05	Over Volt's	0 N/A	All set-ups	FALSE	0	UInt16
15-06	Reset kWh Counter	[0] Do not reset	All set-ups	TRUE	-	UInt8
15-07	Reset Running Hours Counter	[0] Do not reset	All set-ups	TRUE	-	UInt8
15-08	Number of Starts	0 N/A	All set-ups	FALSE	0	UInt32
15-1* Data Log Settings						
15-10	Logging Source	0	2 set-ups	TRUE	-	UInt16
15-11	Logging Interval	ExpressionLimit	2 set-ups	TRUE	-3	TimD
15-12	Trigger Event	[0] False	1 set-up	TRUE	-	UInt8
15-13	Logging Mode	[0] Log always	2 set-ups	TRUE	-	UInt8
15-14	Samples Before Trigger	50 N/A	2 set-ups	TRUE	0	UInt8
15-2* Historic Log						
15-20	Historic Log: Event	0 N/A	All set-ups	FALSE	0	UInt8
15-21	Historic Log: Value	0 N/A	All set-ups	FALSE	0	UInt32
15-22	Historic Log: Time	0 ms	All set-ups	FALSE	-3	UInt32
15-23	Historic log: Date and Time	ExpressionLimit	All set-ups	FALSE	0	TimeOfDay
15-3* Alarm Log						
15-30	Alarm Log: Error Code	0 N/A	All set-ups	FALSE	0	UInt16
15-31	Alarm Log: Value	0 N/A	All set-ups	FALSE	0	Int16
15-32	Alarm Log: Time	0 s	All set-ups	FALSE	0	UInt32
15-33	Alarm Log: Date and Time	ExpressionLimit	All set-ups	FALSE	0	TimeOfDay
15-34	Alarm Log: Status	0 N/A	All set-ups	FALSE	0	UInt8
15-35	Alarm Log: Alarm Text	0 N/A	All set-ups	FALSE	0	VisStr[32]
15-4* Drive Identification						
15-40	FC Type	0 N/A	All set-ups	FALSE	0	VisStr[6]
15-41	Power Section	0 N/A	All set-ups	FALSE	0	VisStr[20]
15-42	Voltage	0 N/A	All set-ups	FALSE	0	VisStr[20]
15-43	Software Version	0 N/A	All set-ups	FALSE	0	VisStr[5]
15-44	Ordered Typecode String	0 N/A	All set-ups	FALSE	0	VisStr[40]
15-45	Actual Typecode String	0 N/A	All set-ups	FALSE	0	VisStr[40]
15-46	Frequency Converter Ordering No	0 N/A	All set-ups	FALSE	0	VisStr[8]
15-47	Power Card Ordering No	0 N/A	All set-ups	FALSE	0	VisStr[8]
15-48	LCP Id No	0 N/A	All set-ups	FALSE	0	VisStr[20]
15-49	SW ID Control Card	0 N/A	All set-ups	FALSE	0	VisStr[20]
15-50	SW ID Power Card	0 N/A	All set-ups	FALSE	0	VisStr[20]
15-51	Frequency Converter Serial Number	0 N/A	All set-ups	FALSE	0	VisStr[10]

Parameter #	Parameter description	Default value	4 set-up	Change during operation	Conversion index	Type
15-53	Power Card Serial Number	0 N/A	All set-ups	FALSE	0	VisStr[19]
15-6* Option Ident						
15-60	Option Mounted	0 N/A	All set-ups	FALSE	0	VisStr[30]
15-61	Option SW Version	0 N/A	All set-ups	FALSE	0	VisStr[20]
15-62	Option Ordering No	0 N/A	All set-ups	FALSE	0	VisStr[8]
15-63	Option Serial No	0 N/A	All set-ups	FALSE	0	VisStr[18]
15-70	Option in Slot A	0 N/A	All set-ups	FALSE	0	VisStr[30]
15-71	Slot A Option SW Version	0 N/A	All set-ups	FALSE	0	VisStr[20]
15-72	Option in Slot B	0 N/A	All set-ups	FALSE	0	VisStr[30]
15-73	Slot B Option SW Version	0 N/A	All set-ups	FALSE	0	VisStr[20]
15-74	Option in Slot C0/E0	0 N/A	All set-ups	FALSE	0	VisStr[30]
15-75	Slot C0/E0 Option SW Version	0 N/A	All set-ups	FALSE	0	VisStr[20]
15-76	Option in Slot C1/E1	0 N/A	All set-ups	FALSE	0	VisStr[30]
15-77	Slot C1/E1 Option SW Version	0 N/A	All set-ups	FALSE	0	VisStr[20]
15-8* Operating Data II						
15-80	Fan Running Hours	0 h	All set-ups	TRUE	74	Uint32
15-81	Preset Fan Running Hours	0 h	All set-ups	TRUE	74	Uint32
15-9* Parameter Info						
15-92	Defined Parameters	0 N/A	All set-ups	FALSE	0	Uint16
15-93	Modified Parameters	0 N/A	All set-ups	FALSE	0	Uint16
15-99	Parameter Metadata	0 N/A	All set-ups	FALSE	0	Uint16

4.1.14 16-** Data Readouts

Parameter #	Parameter description	Default value	4 set-up	Change during operation	Conversion index	Type
16-0* General Status						
16-00	Control Word	0 N/A	All set-ups	FALSE	0	V2
16-01	Reference [Unit]	0 ReferenceFeed-backUnit	All set-ups	FALSE	-3	Int32
16-02	Reference [%]	0 %	All set-ups	FALSE	-1	Int16
16-03	Status Word	0 N/A	All set-ups	FALSE	0	V2
16-05	Main Actual Value [%]	0 %	All set-ups	FALSE	-2	N2
16-09	Custom Readout	0 CustomReadoutUnit	All set-ups	FALSE	-2	Int32
16-1* Motor Status						
16-10	Power [kW]	0 kW	All set-ups	FALSE	1	Int32
16-11	Power [hp]	0 hp	All set-ups	FALSE	-2	Int32
16-12	Motor Voltage	0 V	All set-ups	FALSE	-1	Uint16
16-13	Frequency	0 Hz	All set-ups	FALSE	-1	Uint16
16-14	Motor current	0 A	All set-ups	FALSE	-2	Int32
16-15	Frequency [%]	0 %	All set-ups	FALSE	-2	N2
16-16	Torque [Nm]	0 Nm	All set-ups	FALSE	-1	Int32
16-17	Speed [RPM]	0 RPM	All set-ups	FALSE	67	Int32
16-18	Motor Thermal	0 %	All set-ups	FALSE	0	Uint8
16-22	Torque [%]	0 %	All set-ups	FALSE	0	Int16
16-24	Calibrated Stator Resistance	0.0000 Ohm	All set-ups	TRUE	-4	Uint32
16-3* Drive Status						
16-30	DC Link Voltage	0 V	All set-ups	FALSE	0	Uint16
16-31	System Temp.	0 °C	All set-ups	TRUE	100	Int8
16-32	Brake Energy /s	0 kW	All set-ups	FALSE	0	Uint32
16-33	Brake Energy /2 min	0 kW	All set-ups	FALSE	0	Uint32

Parameter #	Parameter description	Default value	4 set-up	Change during operation	Conversion index	Type
16-34	Heatsink Temp.	0 °C	All set-ups	FALSE	100	Uint8
16-35	Inverter Thermal	0 %	All set-ups	FALSE	0	Uint8
16-36	Inv. Nom. Current	ExpressionLimit	All set-ups	FALSE	-2	Uint32
16-37	Inv. Max. Current	ExpressionLimit	All set-ups	FALSE	-2	Uint32
16-38	SL Controller State	0 N/A	All set-ups	FALSE	0	Uint8
16-39	Control Card Temp.	0 °C	All set-ups	FALSE	100	Uint8
16-40	Logging Buffer Full	[0] No	All set-ups	TRUE	-	Uint8
16-41	LCP Bottom Statusline	0 N/A	All set-ups	TRUE	0	VisStr[50]
16-49	Current Fault Source	0 N/A	All set-ups	TRUE	0	Uint8
16-5* Ref. & Feedb.						
16-50	External Reference	0 N/A	All set-ups	FALSE	-1	Int16
16-52	Feedback[Unit]	0 ProcessCtrlUnit	All set-ups	FALSE	-3	Int32
16-53	Digi Pot Reference	0 N/A	All set-ups	FALSE	-2	Int16
16-54	Feedback 1 [Unit]	0 ProcessCtrlUnit	All set-ups	FALSE	-3	Int32
16-55	Feedback 2 [Unit]	0 ProcessCtrlUnit	All set-ups	FALSE	-3	Int32
16-56	Feedback 3 [Unit]	0 ProcessCtrlUnit	All set-ups	FALSE	-3	Int32
16-6* Inputs & Outputs						
16-60	Digital Input	0 N/A	All set-ups	FALSE	0	Uint16
16-61	Terminal 53 Switch Setting	[0] Current	All set-ups	FALSE	-	Uint8
16-62	Analog Input 53	0 N/A	All set-ups	FALSE	-3	Int32
16-63	Terminal 54 Switch Setting	[0] Current	All set-ups	FALSE	-	Uint8
16-64	Analog Input 54	0 N/A	All set-ups	FALSE	-3	Int32
16-65	Analog Output 42 [mA]	0 N/A	All set-ups	FALSE	-3	Int16
16-66	Digital Output [bin]	0 N/A	All set-ups	FALSE	0	Int16
16-67	Pulse Input #29 [Hz]	0 N/A	All set-ups	FALSE	0	Int32
16-68	Pulse Input #33 [Hz]	0 N/A	All set-ups	FALSE	0	Int32
16-69	Pulse Output #27 [Hz]	0 N/A	All set-ups	FALSE	0	Int32
16-70	Pulse Output #29 [Hz]	0 N/A	All set-ups	FALSE	0	Int32
16-71	Relay Output [bin]	0 N/A	All set-ups	FALSE	0	Int16
16-72	Counter A	0 N/A	All set-ups	TRUE	0	Int32
16-73	Counter B	0 N/A	All set-ups	TRUE	0	Int32
16-75	Analog In X30/11	0 N/A	All set-ups	FALSE	-3	Int32
16-76	Analog In X30/12	0 N/A	All set-ups	FALSE	-3	Int32
16-77	Analog Out X30/8 [mA]	0 N/A	All set-ups	FALSE	-3	Int16
16-78	Analog Out X45/1 [mA]	0 N/A	All set-ups	FALSE	-3	Int16
16-79	Analog Out X45/3 [mA]	0 N/A	All set-ups	FALSE	-3	Int16
16-8* Fieldbus & FC Port						
16-80	Fieldbus CTW 1	0 N/A	All set-ups	FALSE	0	V2
16-82	Fieldbus REF 1	0 N/A	All set-ups	FALSE	0	N2
16-84	Comm. Option STW	0 N/A	All set-ups	FALSE	0	V2
16-85	FC Port CTW 1	0 N/A	All set-ups	FALSE	0	V2
16-86	FC Port REF 1	0 N/A	All set-ups	FALSE	0	N2
16-9* Diagnosis Readouts						
16-90	Alarm Word	0 N/A	All set-ups	FALSE	0	Uint32
16-91	Alarm Word 2	0 N/A	All set-ups	FALSE	0	Uint32
16-92	Warning Word	0 N/A	All set-ups	FALSE	0	Uint32
16-93	Warning Word 2	0 N/A	All set-ups	FALSE	0	Uint32
16-94	Ext. Status Word	0 N/A	All set-ups	FALSE	0	Uint32
16-95	Ext. Status Word 2	0 N/A	All set-ups	FALSE	0	Uint32
16-96	Maintenance Word	0 N/A	All set-ups	FALSE	0	Uint32
16-99	Ext. Status Word 3	0 N/A	All set-ups	FALSE	0	Uint32

4.1.15 18-** Info & Readouts

Parameter #	Parameter description	Default value	4 set-up	Change during operation	Conversion index	Type
18-0* Maintenance Log						
18-00	Maintenance Log: Item	0 N/A	All set-ups	FALSE	0	UInt8
18-01	Maintenance Log: Action	0 N/A	All set-ups	FALSE	0	UInt8
18-02	Maintenance Log: Time	0 s	All set-ups	FALSE	0	UInt32
18-03	Maintenance Log: Date and Time	ExpressionLimit	All set-ups	FALSE	0	TimeOfDay
18-3* Inputs & Outputs						
18-30	Analog Input X42/1	0 N/A	All set-ups	FALSE	-3	Int32
18-31	Analog Input X42/3	0 N/A	All set-ups	FALSE	-3	Int32
18-32	Analog Input X42/5	0 N/A	All set-ups	FALSE	-3	Int32
18-33	Analog Out X42/7 [V]	0 N/A	All set-ups	FALSE	-3	Int16
18-34	Analog Out X42/9 [V]	0 N/A	All set-ups	FALSE	-3	Int16
18-35	Analog Out X42/11 [V]	0 N/A	All set-ups	FALSE	-3	Int16
18-5* Ref. & Feedb.						
18-57	Air Pressure to Flow Air Flow	0 AirPresToFlowUnit	All set-ups	TRUE	0	UInt32
18-6* Inputs & Outputs 2						
18-60	Digital Input 2	0 N/A	All set-ups	FALSE	0	UInt16
18-7* Rectifier Status						
18-70	Mains Voltage	0 V	All set-ups	TRUE	0	UInt16
18-71	Mains Frequency	0 Hz	All set-ups	TRUE	-1	Int16
18-72	Mains Imbalance	0 %	All set-ups	TRUE	-1	UInt16
18-75	Rectifier DC Volt.	0 V	All set-ups	TRUE	0	UInt16

4.1.16 20-** FC Closed Loop

Parameter #	Parameter description	Default value	4 set-up	Change during operation	Conversion index	Type
20-0* Feedback						
20-00	Feedback 1 Source	[2] Analog Input 54	All set-ups	TRUE	-	UInt8
20-01	Feedback 1 Conversion	[2] Pressure to temperature	All set-ups	FALSE	-	UInt8
20-02	Feedback 1 Source Unit	ExpressionLimit	All set-ups	TRUE	-	UInt8
20-03	Feedback 2 Source	[0] No function	All set-ups	TRUE	-	UInt8
20-04	Feedback 2 Conversion	[0] Linear	All set-ups	FALSE	-	UInt8
20-05	Feedback 2 Source Unit	ExpressionLimit	All set-ups	TRUE	-	UInt8
20-06	Feedback 3 Source	[0] No function	All set-ups	TRUE	-	UInt8
20-07	Feedback 3 Conversion	[0] Linear	All set-ups	FALSE	-	UInt8
20-08	Feedback 3 Source Unit	ExpressionLimit	All set-ups	TRUE	-	UInt8
20-12	Reference/Feedback Unit	ExpressionLimit	All set-ups	TRUE	-	UInt8
20-2* Feedback/Setpoint						
20-20	Feedback Function	[3] Minimum	All set-ups	TRUE	-	UInt8
20-21	Setpoint 1	0 ProcessCtrlUnit	All set-ups	TRUE	-3	Int32
20-22	Setpoint 2	0 ProcessCtrlUnit	All set-ups	TRUE	-3	Int32
20-23	Setpoint 3	0 ProcessCtrlUnit	All set-ups	TRUE	-3	Int32
20-25	Setpoint Type	ExpressionLimit	All set-ups	TRUE	-	UInt8
20-3* Feedback Adv. Conv						
20-30	Refrigerant	[19] R404A	All set-ups	TRUE	-	UInt8
20-31	User Defined Refrigerant A1	10 N/A	All set-ups	TRUE	-4	UInt32
20-32	User Defined Refrigerant A2	-2250 N/A	All set-ups	TRUE	-2	Int32
20-33	User Defined Refrigerant A3	250 N/A	All set-ups	TRUE	-3	UInt32
20-4* Thermostat/Pressostat						

Parameter #	Parameter description	Default value	4 set-up	Change during operation	Conversion index	Type
20-40	Thermostat/Pressostat Funktion	ExpressionLimit	All set-ups	TRUE	-	Uint8
20-41	Cut-out Value	ExpressionLimit	All set-ups	TRUE	-3	Int32
20-42	Cut-in Value	ExpressionLimit	All set-ups	TRUE	-3	Int32
20-7* PID Autotuning						
20-70	Closed Loop Type	[0] Auto	2 set-ups	TRUE	-	Uint8
20-71	PID Performance	[0] Normal	2 set-ups	TRUE	-	Uint8
20-72	PID Output Change	0.10 N/A	2 set-ups	TRUE	-2	Uint16
20-73	Minimum Feedback Level	-999999 ProcessCtrlUnit	2 set-ups	TRUE	-3	Int32
20-74	Maximum Feedback Level	999999 ProcessCtrlUnit	2 set-ups	TRUE	-3	Int32
20-79	PID Autotuning	[0] Disabled	All set-ups	TRUE	-	Uint8
20-8* PID Basic Settings						
20-81	PID Normal/ Inverse Control	[1] Inverse	All set-ups	TRUE	-	Uint8
20-82	PID Start Speed [RPM]	ExpressionLimit	All set-ups	TRUE	67	Uint16
20-83	PID Start Speed [Hz]	ExpressionLimit	All set-ups	TRUE	-1	Uint16
20-84	On Reference Bandwidth	5 %	All set-ups	TRUE	0	Uint8
20-9* PID Controller						
20-91	PID Anti Windup	[1] On	All set-ups	TRUE	-	Uint8
20-93	PID Proportional Gain	0.50 N/A	All set-ups	TRUE	-2	Uint16
20-94	PID Integral Time	30 s	All set-ups	TRUE	-2	Uint32
20-95	PID Differentiation Time	0 s	All set-ups	TRUE	-2	Uint16
20-96	PID Diff. Gain Limit	5 N/A	All set-ups	TRUE	-1	Uint16

4.1.17 21-** Ext. Closed Loop

Parameter #	Parameter description	Default value	4 set-up	Change during operation	Conversion index	Type
21-0* Ext. CL Autotuning						
21-00	Closed Loop Type	[0] Auto	2 set-ups	TRUE	-	Uint8
21-01	PID Performance	[0] Normal	2 set-ups	TRUE	-	Uint8
21-02	PID Output Change	0.10 N/A	2 set-ups	TRUE	-2	Uint16
21-03	Minimum Feedback Level	-999999 N/A	2 set-ups	TRUE	-3	Int32
21-04	Maximum Feedback Level	999999 N/A	2 set-ups	TRUE	-3	Int32
21-09	PID Autotuning	[0] Disabled	All set-ups	TRUE	-	Uint8
21-1* Ext. CL 1 Ref./Fb.						
21-10	Ext. 1 Ref./Feedback Unit	[1] %	All set-ups	TRUE	-	Uint8
21-11	Ext. 1 Minimum Reference	0 ExtPID1Unit	All set-ups	TRUE	-3	Int32
21-12	Ext. 1 Maximum Reference	100 ExtPID1Unit	All set-ups	TRUE	-3	Int32
21-13	Ext. 1 Reference Source	[0] No function	All set-ups	TRUE	-	Uint8
21-14	Ext. 1 Feedback Source	[0] No function	All set-ups	TRUE	-	Uint8
21-15	Ext. 1 Setpoint	0 ExtPID1Unit	All set-ups	TRUE	-3	Int32
21-16	Ext. 1 PID Conversion	[0] Linear	All set-ups	TRUE	-	Uint8
21-17	Ext. 1 Reference [Unit]	0 ExtPID1Unit	All set-ups	TRUE	-3	Int32
21-18	Ext. 1 Feedback [Unit]	0 ExtPID1Unit	All set-ups	TRUE	-3	Int32
21-19	Ext. 1 Output [%]	0 %	All set-ups	TRUE	0	Int32
21-2* Ext. CL 1 PID						
21-20	Ext. 1 Normal/Inverse Control	[0] Normal	All set-ups	TRUE	-	Uint8
21-21	Ext. 1 Proportional Gain	0.01 N/A	All set-ups	TRUE	-2	Uint16
21-22	Ext. 1 Integral Time	10000 s	All set-ups	TRUE	-2	Uint32
21-23	Ext. 1 Differentiation Time	0 s	All set-ups	TRUE	-2	Uint16
21-24	Ext. 1 Dif. Gain Limit	5 N/A	All set-ups	TRUE	-1	Uint16

Parameter #	Parameter description	Default value	4 set-up	Change during operation	Conversion index	Type
21-3* Ext. CL 2 Ref./Fb.						
21-30	Ext. 2 Ref./Feedback Unit	[1] %	All set-ups	TRUE	-	UInt8
21-31	Ext. 2 Minimum Reference	0 ExtPID2Unit	All set-ups	TRUE	-3	Int32
21-32	Ext. 2 Maximum Reference	100 ExtPID2Unit	All set-ups	TRUE	-3	Int32
21-33	Ext. 2 Reference Source	[0] No function	All set-ups	TRUE	-	UInt8
21-34	Ext. 2 Feedback Source	[0] No function	All set-ups	TRUE	-	UInt8
21-35	Ext. 2 Setpoint	0 ExtPID2Unit	All set-ups	TRUE	-3	Int32
21-36	Ext. 2 PID Conversion	[0] Linear	All set-ups	TRUE	-	UInt8
21-37	Ext. 2 Reference [Unit]	0 ExtPID2Unit	All set-ups	TRUE	-3	Int32
21-38	Ext. 2 Feedback [Unit]	0 ExtPID2Unit	All set-ups	TRUE	-3	Int32
21-39	Ext. 2 Output [%]	0 %	All set-ups	TRUE	0	Int32
21-4* Ext. CL 2 PID						
21-40	Ext. 2 Normal/Inverse Control	[0] Normal	All set-ups	TRUE	-	UInt8
21-41	Ext. 2 Proportional Gain	0.01 N/A	All set-ups	TRUE	-2	UInt16
21-42	Ext. 2 Integral Time	10000 s	All set-ups	TRUE	-2	UInt32
21-43	Ext. 2 Differentiation Time	0 s	All set-ups	TRUE	-2	UInt16
21-44	Ext. 2 Dif. Gain Limit	5 N/A	All set-ups	TRUE	-1	UInt16
21-5* Ext. CL 3 Ref./Fb.						
21-50	Ext. 3 Ref./Feedback Unit	[1] %	All set-ups	TRUE	-	UInt8
21-51	Ext. 3 Minimum Reference	0 ExtPID3Unit	All set-ups	TRUE	-3	Int32
21-52	Ext. 3 Maximum Reference	100 ExtPID3Unit	All set-ups	TRUE	-3	Int32
21-53	Ext. 3 Reference Source	[0] No function	All set-ups	TRUE	-	UInt8
21-54	Ext. 3 Feedback Source	[0] No function	All set-ups	TRUE	-	UInt8
21-55	Ext. 3 Setpoint	0 ExtPID3Unit	All set-ups	TRUE	-3	Int32
21-56	Ext. 3 PID Conversion	[0] Linear	All set-ups	TRUE	-	UInt8
21-57	Ext. 3 Reference [Unit]	0 ExtPID3Unit	All set-ups	TRUE	-3	Int32
21-58	Ext. 3 Feedback [Unit]	0 ExtPID3Unit	All set-ups	TRUE	-3	Int32
21-59	Ext. 3 Output [%]	0 %	All set-ups	TRUE	0	Int32
21-6* Ext. CL 3 PID						
21-60	Ext. 3 Normal/Inverse Control	[0] Normal	All set-ups	TRUE	-	UInt8
21-61	Ext. 3 Proportional Gain	0.01 N/A	All set-ups	TRUE	-2	UInt16
21-62	Ext. 3 Integral Time	10000 s	All set-ups	TRUE	-2	UInt32
21-63	Ext. 3 Differentiation Time	0 s	All set-ups	TRUE	-2	UInt16
21-64	Ext. 3 Dif. Gain Limit	5 N/A	All set-ups	TRUE	-1	UInt16
21-7* Ext. Feedb. Adv. Conversion						
21-70	Refrigerant	[19] R404A	All set-ups	TRUE	-	UInt8
21-71	User Defined Refrigerant A1	10 N/A	All set-ups	TRUE	-4	UInt32
21-72	User Defined Refrigerant A2	-2250 N/A	All set-ups	TRUE	-2	Int32
21-73	User Defined Refrigerant A3	250 N/A	All set-ups	TRUE	-3	UInt32

4.1.18 22-** Application Functions

Parameter #	Parameter description	Default value	4 set-up	Change during operation	Conversion index	Type
22-0* Miscellaneous						
22-00	External Interlock Delay	0 s	All set-ups	TRUE	0	UInt16
22-1* Air Pres. to Flow						
22-10	Air Pressure to Flow Signal source	[0] No function	All set-ups	TRUE	-	UInt8
22-11	Air Pressure to Flow Fan k-factor	1000 N/A	All set-ups	TRUE	0	UInt16
22-12	Air Pressure to Flow Air density	1.2 N/A	All set-ups	TRUE	-3	UInt16
22-13	Air Pressure to Flow Fan flow unit	[0] m ³ /h	All set-ups	TRUE	-	UInt8
22-2* No-Flow Detection						

Parameter #	Parameter description	Default value	4 set-up	Change during operation	Conversion index	Type
22-20	Low Power Auto Set-up	[0] Off	All set-ups	FALSE	-	Uint8
22-21	Low Power Detection	[0] Disabled	All set-ups	TRUE	-	Uint8
22-22	Low Speed Detection	[0] Disabled	All set-ups	TRUE	-	Uint8
22-23	No-Flow Function	[0] Off	All set-ups	TRUE	-	Uint8
22-24	No-Flow Delay	10 s	All set-ups	TRUE	0	Uint16
22-26	Dry Pump Function	[0] Off	All set-ups	TRUE	-	Uint8
22-27	Dry Pump Delay	10 s	All set-ups	TRUE	0	Uint16
22-3* No-Flow Power Tuning						
22-30	No-Flow Power	0 kW	All set-ups	TRUE	1	Uint32
22-31	Power Correction Factor	100 %	All set-ups	TRUE	0	Uint16
22-32	Low Speed [RPM]	ExpressionLimit	All set-ups	TRUE	67	Uint16
22-33	Low Speed [Hz]	ExpressionLimit	All set-ups	TRUE	-1	Uint16
22-34	Low Speed Power [kW]	ExpressionLimit	All set-ups	TRUE	1	Uint32
22-35	Low Speed Power [HP]	ExpressionLimit	All set-ups	TRUE	-2	Uint32
22-36	High Speed [RPM]	ExpressionLimit	All set-ups	TRUE	67	Uint16
22-37	High Speed [Hz]	ExpressionLimit	All set-ups	TRUE	-1	Uint16
22-38	High Speed Power [kW]	ExpressionLimit	All set-ups	TRUE	1	Uint32
22-39	High Speed Power [HP]	ExpressionLimit	All set-ups	TRUE	-2	Uint32
22-4* Sleep Mode						
22-40	Minimum Run Time	10 s	All set-ups	TRUE	0	Uint16
22-41	Minimum Sleep Time	10 s	All set-ups	TRUE	0	Uint16
22-42	Wake-up Speed [RPM]	ExpressionLimit	All set-ups	TRUE	67	Uint16
22-43	Wake-up Speed [Hz]	ExpressionLimit	All set-ups	TRUE	-1	Uint16
22-44	Wake-up Ref./FB Difference	10 %	All set-ups	TRUE	0	Int8
22-45	Setpoint Boost	0 %	All set-ups	TRUE	0	Int8
22-46	Maximum Boost Time	60 s	All set-ups	TRUE	0	Uint16
22-5* End of Curve						
22-50	End of Curve Function	[0] Off	All set-ups	TRUE	-	Uint8
22-51	End of Curve Delay	10 s	All set-ups	TRUE	0	Uint16
22-6* Broken Belt Detection						
22-60	Broken Belt Function	[0] Off	All set-ups	TRUE	-	Uint8
22-61	Broken Belt Torque	10 %	All set-ups	TRUE	0	Uint8
22-62	Broken Belt Delay	10 s	All set-ups	TRUE	0	Uint16
22-7* Short Cycle Protection						
22-75	Short Cycle Protection	[0] Disabled	All set-ups	TRUE	-	Uint8
22-76	Interval between Starts	300 s	All set-ups	TRUE	0	Uint16
22-77	Minimum Run Time	0 s	All set-ups	TRUE	0	Uint16
22-78	Minimum Run Time Override	[0] Disabled	All set-ups	FALSE	-	Uint8
22-79	Minimum Run Time Override Value	0 ProcessCtrlUnit	All set-ups	TRUE	-3	Int32
22-8* Flow Compensation						
22-80	Flow Compensation	[0] Disabled	All set-ups	TRUE	-	Uint8
22-81	Square-linear Curve Approximation	100 %	All set-ups	TRUE	0	Uint8
22-82	Work Point Calculation	[0] Disabled	All set-ups	TRUE	-	Uint8
22-83	Speed at No-Flow [RPM]	ExpressionLimit	All set-ups	TRUE	67	Uint16
22-84	Speed at No-Flow [Hz]	ExpressionLimit	All set-ups	TRUE	-1	Uint16
22-85	Speed at Design Point [RPM]	ExpressionLimit	All set-ups	TRUE	67	Uint16
22-86	Speed at Design Point [Hz]	ExpressionLimit	All set-ups	TRUE	-1	Uint16
22-87	Pressure at No-Flow Speed	0 N/A	All set-ups	TRUE	-3	Int32
22-88	Pressure at Rated Speed	999999 N/A	All set-ups	TRUE	-3	Int32
22-89	Flow at Design Point	0 N/A	All set-ups	TRUE	-3	Int32
22-90	Flow at Rated Speed	0 N/A	All set-ups	TRUE	-3	Int32

4.1.19 23-** Time Based Functions

Parameter #	Parameter description	Default value	4 set-up	Change during operation	Conversion index	Type
23-0* Timed Actions						
23-00	ON Time	ExpressionLimit	2 set-ups	TRUE	0	TimeOfDay-WoDate
23-01	ON Action	[0] Disabled	2 set-ups	TRUE	-	Uint8
23-02	OFF Time	ExpressionLimit	2 set-ups	TRUE	0	TimeOfDay-WoDate
23-03	OFF Action	[0] Disabled	2 set-ups	TRUE	-	Uint8
23-04	Occurrence	[0] All days	2 set-ups	TRUE	-	Uint8
23-1* Maintenance						
23-10	Maintenance Item	[1] Motor bearings	1 set-up	TRUE	-	Uint8
23-11	Maintenance Action	[1] Lubricate	1 set-up	TRUE	-	Uint8
23-12	Maintenance Time Base	[0] Disabled	1 set-up	TRUE	-	Uint8
23-13	Maintenance Time Interval	1 h	1 set-up	TRUE	74	Uint32
23-14	Maintenance Date and Time	ExpressionLimit	1 set-up	TRUE	0	TimeOfDay
23-1* Maintenance Reset						
23-15	Reset Maintenance Word	[0] Do not reset	All set-ups	TRUE	-	Uint8
23-16	Maintenance Text	0 N/A	1 set-up	TRUE	0	VisStr[20]
23-5* Energy Log						
23-50	Energy Log Resolution	[5] Last 24 Hours	2 set-ups	TRUE	-	Uint8
23-51	Period Start	ExpressionLimit	2 set-ups	TRUE	0	TimeOfDay
23-53	Energy Log	0 N/A	All set-ups	TRUE	0	Uint32
23-54	Reset Energy Log	[0] Do not reset	All set-ups	TRUE	-	Uint8
23-6* Trending						
23-60	Trend Variable	[0] Power [kW]	2 set-ups	TRUE	-	Uint8
23-61	Continuous Bin Data	0 N/A	All set-ups	TRUE	0	Uint32
23-62	Timed Bin Data	0 N/A	All set-ups	TRUE	0	Uint32
23-63	Timed Period Start	ExpressionLimit	2 set-ups	TRUE	0	TimeOfDay
23-64	Timed Period Stop	ExpressionLimit	2 set-ups	TRUE	0	TimeOfDay
23-65	Minimum Bin Value	ExpressionLimit	2 set-ups	TRUE	0	Uint8
23-66	Reset Continuous Bin Data	[0] Do not reset	All set-ups	TRUE	-	Uint8
23-67	Reset Timed Bin Data	[0] Do not reset	All set-ups	TRUE	-	Uint8
23-8* Payback Counter						
23-80	Power Reference Factor	100 %	2 set-ups	TRUE	0	Uint8
23-81	Energy Cost	1 N/A	2 set-ups	TRUE	-2	Uint32
23-82	Investment	0 N/A	2 set-ups	TRUE	0	Uint32
23-83	Energy Savings	0 kWh	All set-ups	TRUE	75	Int32
23-84	Cost Savings	0 N/A	All set-ups	TRUE	0	Int32

4.1.20 25-** Pack Controller

Parameter #	Parameter description	Default value	4 set-up	Change during operation	Conversion index	Type
25-0* System Settings						
25-00	Pack Controller	[0] Disabled	2 set-ups	FALSE	-	Uint8
25-02	Motor Start	[0] Direct on Line	2 set-ups	FALSE	-	Uint8
25-04	Pump Cycling	[0] Disabled	All set-ups	TRUE	-	Uint8
25-05	Fixed Lead Compressor	[1] Yes	2 set-ups	FALSE	-	Uint8
25-06	Number of Compressors	2 N/A	2 set-ups	FALSE	0	Uint8
25-2* Zone Settings						

Parameter #	Parameter description	Default value	4 set-up	Change during operation	Conversion index	Type
25-20	Neutral Zone [unit]	4 ReferenceFeed-backUnit	All set-ups	TRUE	-2	UInt32
25-21	+ Zone [unit]	3 ReferenceFeed-backUnit	All set-ups	TRUE	-2	UInt32
25-22	- Zone [unit]	3 ReferenceFeed-backUnit	All set-ups	TRUE	-2	UInt32
25-23	Fixed Speed neutral Zone [unit]	4 ReferenceFeed-backUnit	All set-ups	TRUE	-2	UInt32
25-24	+ Zone Delay	120 s	All set-ups	TRUE	0	UInt32
25-25	- Zone Delay	60 s	All set-ups	TRUE	0	UInt32
25-26	++ Zone Delay	60 s	All set-ups	TRUE	0	UInt32
25-27	-- Zone Delay	30 s	All set-ups	TRUE	0	UInt32
25-28	Override Bandwidth Ramp Time	ExpressionLimit	All set-ups	TRUE	-2	UInt32
25-3* Staging Functions						
25-30	Destage At No-Flow	[0] Disabled	All set-ups	TRUE	-	UInt8
25-31	Stage Function	[0] Disabled	All set-ups	TRUE	-	UInt8
25-32	Stage Function Time	15 s	All set-ups	TRUE	0	UInt16
25-33	Destage Function	[0] Disabled	All set-ups	TRUE	-	UInt8
25-34	Destage Function Time	15 s	All set-ups	TRUE	0	UInt16
25-4* Staging Settings						
25-42	Staging Threshold	ExpressionLimit	All set-ups	TRUE	0	UInt8
25-43	Destaging Threshold	ExpressionLimit	All set-ups	TRUE	0	UInt8
25-44	Staging Speed [RPM]	0 RPM	All set-ups	TRUE	67	UInt16
25-45	Staging Speed [Hz]	0 Hz	All set-ups	TRUE	-1	UInt16
25-46	Destaging Speed [RPM]	0 RPM	All set-ups	TRUE	67	UInt16
25-47	Destaging Speed [Hz]	0 Hz	All set-ups	TRUE	-1	UInt16
25-5* Alternation Settings						
25-50	Lead Pump Alternation	[0] Off	All set-ups	TRUE	-	UInt8
25-51	Alternation Event	[0] External	All set-ups	TRUE	-	UInt8
25-52	Alternation Time Interval	24 h	All set-ups	TRUE	74	UInt16
25-53	Alternation Timer Value	0 N/A	All set-ups	TRUE	0	VisStr[7]
25-54	Alternation Predefined Time	ExpressionLimit	All set-ups	TRUE	0	TimeOfDay-WoDate
25-55	Alternate if Load < 50%	[1] Enabled	All set-ups	TRUE	-	UInt8
25-56	Staging Mode at Alternation	[0] Slow	All set-ups	TRUE	-	UInt8
25-58	Run Next Pump Delay	0.1 s	All set-ups	TRUE	-1	UInt16
25-59	Run on Mains Delay	0.5 s	All set-ups	TRUE	-1	UInt16
25-8* Status						
25-80	Pack Status	0 N/A	All set-ups	TRUE	0	VisStr[25]
25-81	Compressor Status	0 N/A	All set-ups	TRUE	0	VisStr[25]
25-82	Lead Compressor	0 N/A	All set-ups	TRUE	0	UInt8
25-83	Relay Status	0 N/A	All set-ups	TRUE	0	VisStr[4]
25-84	Compressor ON Time	0 h	All set-ups	TRUE	74	UInt32
25-85	Relay ON Time	0 h	All set-ups	TRUE	74	UInt32
25-86	Reset Relay Counters	[0] Do not reset	All set-ups	TRUE	-	UInt8
25-87	Inverse Interlock	0 N/A	All set-ups	TRUE	0	UInt16
25-88	Pack capacity [%]	0 %	All set-ups	TRUE	0	UInt16
25-9* Service						
25-90	Compressor Interlock	[0] Off	All set-ups	TRUE	-	UInt8
25-91	Manual Alternation	0 N/A	All set-ups	TRUE	0	UInt8

4.1.21 26-** Analog I/O Option MCB 109

4

Parameter #	Parameter description	Default value	4 set-up	Change during operation	Conversion index	Type
26-0* Analog I/O Mode						
26-00	Terminal X42/1 Mode	[1] Voltage	All set-ups	TRUE	-	Uint8
26-01	Terminal X42/3 Mode	[1] Voltage	All set-ups	TRUE	-	Uint8
26-02	Terminal X42/5 Mode	[1] Voltage	All set-ups	TRUE	-	Uint8
26-1* Analog Input X42/1						
26-10	Terminal X42/1 Low Voltage	0.07 V	All set-ups	TRUE	-2	Int16
26-11	Terminal X42/1 High Voltage	10 V	All set-ups	TRUE	-2	Int16
26-14	Term. X42/1 Low Ref./Feedb. Value	0 N/A	All set-ups	TRUE	-3	Int32
26-15	Term. X42/1 High Ref./Feedb. Value	100 N/A	All set-ups	TRUE	-3	Int32
26-16	Term. X42/1 Filter Time Constant	0.001 s	All set-ups	TRUE	-3	Uint16
26-17	Term. X42/1 Live Zero	[1] Enabled	All set-ups	TRUE	-	Uint8
26-2* Analog Input X42/3						
26-20	Terminal X42/3 Low Voltage	0.07 V	All set-ups	TRUE	-2	Int16
26-21	Terminal X42/3 High Voltage	10 V	All set-ups	TRUE	-2	Int16
26-24	Term. X42/3 Low Ref./Feedb. Value	0 N/A	All set-ups	TRUE	-3	Int32
26-25	Term. X42/3 High Ref./Feedb. Value	100 N/A	All set-ups	TRUE	-3	Int32
26-26	Term. X42/3 Filter Time Constant	0.001 s	All set-ups	TRUE	-3	Uint16
26-27	Term. X42/3 Live Zero	[1] Enabled	All set-ups	TRUE	-	Uint8
26-3* Analog Input X42/5						
26-30	Terminal X42/5 Low Voltage	0.07 V	All set-ups	TRUE	-2	Int16
26-31	Terminal X42/5 High Voltage	10 V	All set-ups	TRUE	-2	Int16
26-34	Term. X42/5 Low Ref./Feedb. Value	0 N/A	All set-ups	TRUE	-3	Int32
26-35	Term. X42/5 High Ref./Feedb. Value	100 N/A	All set-ups	TRUE	-3	Int32
26-36	Term. X42/5 Filter Time Constant	0.001 s	All set-ups	TRUE	-3	Uint16
26-37	Term. X42/5 Live Zero	[1] Enabled	All set-ups	TRUE	-	Uint8
26-4* Analog Out X42/7						
26-40	Terminal X42/7 Output	[0] No operation	All set-ups	TRUE	-	Uint8
26-41	Terminal X42/7 Min. Scale	0 %	All set-ups	TRUE	-2	Int16
26-42	Terminal X42/7 Max. Scale	100 %	All set-ups	TRUE	-2	Int16
26-43	Terminal X42/7 Bus Control	0 %	All set-ups	TRUE	-2	N2
26-44	Terminal X42/7 Timeout Preset	0 %	1 set-up	TRUE	-2	Uint16
26-5* Analog Out X42/9						
26-50	Terminal X42/9 Output	[0] No operation	All set-ups	TRUE	-	Uint8
26-51	Terminal X42/9 Min. Scale	0 %	All set-ups	TRUE	-2	Int16
26-52	Terminal X42/9 Max. Scale	100 %	All set-ups	TRUE	-2	Int16
26-53	Terminal X42/9 Bus Control	0 %	All set-ups	TRUE	-2	N2
26-54	Terminal X42/9 Timeout Preset	0 %	1 set-up	TRUE	-2	Uint16
26-6* Analog Out X42/11						
26-60	Terminal X42/11 Output	[0] No operation	All set-ups	TRUE	-	Uint8
26-61	Terminal X42/11 Min. Scale	0 %	All set-ups	TRUE	-2	Int16
26-62	Terminal X42/11 Max. Scale	100 %	All set-ups	TRUE	-2	Int16
26-63	Terminal X42/11 Bus Control	0 %	All set-ups	TRUE	-2	N2
26-64	Terminal X42/11 Timeout Preset	0 %	1 set-up	TRUE	-2	Uint16

4.1.22 28-** Compressor Functions

Parameter #	Parameter description	Default value	4 set-up	Change during operation	Conversion index	Type
28-1* Oil Return Management						
28-10	Oil Return Management	[0] Off	All set-ups	FALSE	-	Uint8
28-11	Low Speed Running Time	60 min	All set-ups	TRUE	70	Uint16
28-12	Fixed Boost Interval	24 h	All set-ups	TRUE	74	Uint8
28-13	Boost Duration	30 s	All set-ups	FALSE	0	Uint8
28-14	Adequate oil return speed [RPM]	ExpressionLimit	All set-ups	TRUE	67	Uint16
28-15	Adequate oil return speed [Hz]	ExpressionLimit	All set-ups	TRUE	-1	Uint16
28-16	Oil boost speed [RPM]	ExpressionLimit	All set-ups	TRUE	67	Uint16
28-17	Oil boost speed [Hz]	ExpressionLimit	All set-ups	TRUE	-1	Uint16
28-18	Cancel oil boost at low feedback	-999999.999 ProcessCtrlUnit	2 set-ups	TRUE	-3	Int32
28-19	Cancel oil boost at high feedback	999999.999 ProcessCtrlUnit	2 set-ups	TRUE	-3	Int32
28-2* Discharge Temperature Monitor						
28-20	Temperature Source	[0] None	All set-ups	FALSE	-	Uint8
28-21	Temperature Unit	[60] °C	All set-ups	FALSE	-	Uint8
28-24	Warning Level	130 N/A	All set-ups	FALSE	0	Uint16
28-25	Warning Action	[1] Decrease cooling	All set-ups	FALSE	-	Uint8
28-26	Emergency Level	145 N/A	All set-ups	FALSE	0	Uint16
28-27	Discharge Temperature	0 DTM_ReadoutUnit	All set-ups	TRUE	0	Int32
28-7* Day/Night Settings						
28-71	Day/Night Bus Indicator	[0] Day	All set-ups	TRUE	-	Uint8
28-72	Enable Day/Night Via Bus	[0] Disabled	All set-ups	TRUE	-	Uint8
28-73	Night Setback	0 ReferenceFeed- backUnit	All set-ups	TRUE	-3	Int32
28-74	Night Speed Drop [RPM]	ExpressionLimit	All set-ups	TRUE	67	Uint16
28-75	Night Speed Drop Override	0 N/A	All set-ups	TRUE	-3	Int32
28-76	Night Speed Drop [Hz]	ExpressionLimit	All set-ups	TRUE	-1	Uint16
28-8* P0 Optimization						
28-81	dP0 Offset	0 K	All set-ups	TRUE	-1	Int32
28-82	P0	0 K	All set-ups	TRUE	-3	Int32
28-83	P0 Setpoint	0 K	All set-ups	TRUE	-3	Int32
28-84	P0 Reference	0 K	All set-ups	TRUE	-3	Int32
28-85	P0 Minimum Reference	0 K	All set-ups	TRUE	0	Int32
28-86	P0 Maximum Reference	0 K	All set-ups	TRUE	0	Int32
28-87	Most Loaded Controller	0 N/A	All set-ups	TRUE	0	Int16
28-9* Injection Control						
28-90	Injection On	[0] Off	All set-ups	TRUE	-	Uint8
28-91	Delayed Compressor Start	[0] No	All set-ups	TRUE	-	Uint8

4.1.23 29-** Compressor Functions 2

Parameter #	Parameter description	Default value	4 set-up	Change during operation	Conversion index	Type
29-4* Pre/Post Lube						
29-40	Pre/Post Lube Function	[0] Disabled	All set-ups	TRUE	-	Uint8
29-41	Pre Lube Time	10 s	All set-ups	TRUE	0	Uint16
29-42	Post Lube Time	10 s	All set-ups	TRUE	0	Uint16

4.1.24 30-** Special Features

4

Parameter #	Parameter description	Default value	4 set-up	Change during operation	Conversion index	Type
30-2* Adv. Start Adjust						
30-22	Locked Rotor Protection	ExpressionLimit	All set-ups	TRUE	-	Uint8
30-23	Locked Rotor Detection Time [s]	ExpressionLimit	All set-ups	TRUE	-2	Uint8
30-3* High/Low Pres. Stop 1						
30-30	Pressure Transmitter	[0] No function	All set-ups	TRUE	-	uint8
30-31	Pressure Conversion	[0] Linear	All set-ups	TRUE	-	uint8
30-32	Pressure Source Unit	[71] bar	All set-ups	TRUE	-	uint8
30-33	Temperature Unit	ExpressionLimit	All set-ups	TRUE	-	Uint8
30-34	High Pres. Stop	999999.999 HplpResultUnit0	All set-ups	TRUE	-3	Int32
30-35	High Pres. Start	hplp_max_pressure 0 (P3034)	All set-ups	TRUE	-3	Int32
30-36	Low Pres. Stop	-999999.999 HplpResultUnit0	All set-ups	TRUE	-3	Int32
30-37	Low Pres. Start	hplp_min_pressure 0 (P3036)	All set-ups	TRUE	-3	Int32
30-38	Pressure 1	0 HplpResultUnit0	All set-ups	TRUE	-3	Int32
30-4* High/Low Pres. Stop 2						
30-40	Pressure Transmitter	[0] No function	All set-ups	TRUE	-	uint8
30-41	Pressure Conversion	[0] Linear	All set-ups	TRUE	-	uint8
30-42	Pressure Source Unit	[71] bar	All set-ups	TRUE	-	uint8
30-43	Temperature Unit	ExpressionLimit	All set-ups	TRUE	-	Uint8
30-44	High Pres. Stop	999999.999 HplpResultUnit1	All set-ups	TRUE	-3	Int32
30-45	High Pres. Start	hplp_max_pressure 1 (P3044)	All set-ups	TRUE	-3	Int32
30-46	Low Pres. Stop	-999999.999 HplpResultUnit1	All set-ups	TRUE	-3	Int32
30-47	Low Pres. Start	hplp_min_pressure 1 (P3046)	All set-ups	TRUE	-3	Int32
30-48	Pressure 2	0 HplpResultUnit1	All set-ups	TRUE	-3	Int32
30-4* High/Low Pres. Ramp						
30-49	Pressure Stop Ramp Time	ExpressionLimit	All set-ups	TRUE	-2	Uint32
30-5* Unit Configuration						
30-50	Heat Sink Fan Mode	ExpressionLimit	2 set-ups	TRUE	-	uint8

5 Troubleshooting

5.1 Status Messages

5.1.1 Alarms and Warnings

A warning or an alarm is signalled by the relevant LED on the front of the frequency converter and indicated by a code on the display.

A warning remains active until its cause is no longer present. Under certain circumstances, operation of the motor may still be continued. Warning messages may be critical, but are not necessarily so.

If an alarm occurs, the frequency converter trips. Reset alarms to restart operation once their cause has been rectified. Reset the alarm in any of the following ways:

- By pressing [Reset].
- Via a digital input with the reset function.
- Via serial communication/optional fieldbus.
- By resetting automatically using the auto-reset function, see *parameter 14-20 Reset Mode*.

NOTICE

After a manual reset pressing [Reset], press [Auto On] to restart the motor.

If an alarm cannot be reset, maybe the cause has not been rectified, or the alarm is trip-locked (see also *Table 5.1*).

Alarms that are trip-locked offer additional protection, meaning that the mains supply must be switched off before the alarm can be reset. After being switched back on, the frequency converter is no longer blocked and may be reset as described above, once the cause has been rectified.

Alarms that are not trip-locked can also be reset using the automatic reset function in *parameter 14-20 Reset Mode*.

WARNING

AUTOMATIC WAKE-UP

The automatic reset function may trigger the automatic wake-up of the frequency converter and the motor may start running. Before performing the automatic reset function, ensure that the running motor does not cause damage or injury.

If a warning and alarm is marked against a code in *Table 5.1*, this means that either a warning occurs before an alarm, or it can be specified whether it is a warning or an alarm that is to be displayed for a given fault.

This is possible, for instance, in *parameter 1-90 Motor Thermal Protection*. After an alarm or trip, the motor carries on coasting, and the alarm and warning flash on the frequency converter. Once the problem has been rectified, only the alarm continues flashing.

No.	Description	Warning	Alarm/Trip	Alarm/Trip Lock	Parameter Reference
1	10 Volts low	X			
2	Live zero error	(X)	(X)		<i>Parameter 6-01 Live Zero Timeout Function</i>
3	No motor	(X)			<i>Parameter 1-80 Function at Stop</i>
4	Mains phase loss	(X)	(X)	(X)	<i>Parameter 14-12 Function at Mains Imbalance</i>
5	DC link voltage high	X			
6	DC link voltage low	X			
7	DC over voltage	X	X		
8	DC under voltage	X	X		
9	Inverter overloaded	X	X		
10	Motor ETR over temperature	(X)	(X)		<i>Parameter 1-90 Motor Thermal Protection</i>
11	Motor thermistor over temperature	(X)	(X)		<i>Parameter 1-90 Motor Thermal Protection</i>
12	Torque limit	X	X		
13	Over Current	X	X	X	
14	Earth fault	X	X	X	
15	Incomp. HW		X	X	

No.	Description	Warning	Alarm/Trip	Alarm/Trip Lock	Parameter Reference
16	Short Circuit		X	X	
17	Control word timeout	(X)	(X)		<i>Parameter 8-04 Control Timeout Function</i>
18	Start Failed				
19	Discharge Temperature High				
23	Internal fans				
24	External fans				
29	Power board over temp	X	X	X	
30	Motor phase U missing	(X)	(X)	(X)	<i>Parameter 4-58 Missing Motor Phase Function</i>
31	Motor phase V missing	(X)	(X)	(X)	<i>Parameter 4-58 Missing Motor Phase Function</i>
32	Motor phase W missing	(X)	(X)	(X)	<i>Parameter 4-58 Missing Motor Phase Function</i>
33	Inrush fault		X	X	
34	Fieldbus communication fault	X	X		
36	Mains failure				
38	Internal fault		X	X	
40	Overload T27				
41	Overload T29				
42	Overload X30/6-7				
47	24 V supply low	X	X	X	
48	1.8 V supply low		X	X	
49	Speed limit				
50	AMA calibration failed		X		
51	AMA check U_{nom} and I_{nom}		X		
52	AMA low I_{nom}		X		
53	AMA motor too big		X		
54	AMA motor too small		X		
55	AMA parameter out of range		X		
56	AMA interrupted by user		X		
57	AMA timeout		X		
58	AMA internal fault	X	X		
59	Current limit	X			
60	External interlock				
62	Output Frequency at Maximum Limit	X			
64	Voltage Limit	X			
65	Control Board Over-temperature	X	X	X	
66	Heat sink Temperature Low	X			
67	Option Configuration has Changed		X		
68	Safe Stop Activated		X		
70	Illegal FC configuration				
80	Drive Initialised to Default Value		X		
92	No-Flow	X	X		<i>Parameter group 22-2* No-Flow Detection</i>
93	Dry Pump	X	X		<i>Parameter group 22-2* No-Flow Detection</i>
94	End of Curve	X	X		<i>Parameter group 22-5* End of Curve</i>
95	Broken Belt	X	X		<i>Parameter group 22-6* Broken Belt Detection</i>
96	Start Delayed	X			<i>Parameter group 22-7* Short Cycle Protection</i>

No.	Description	Warning	Alarm/Trip	Alarm/Trip Lock	Parameter Reference
97	Stop Delayed	X			Parameter group 22-7* Short Cycle Protection
98	Clock Fault	X			Parameter group 0-7* Clock Settings
250	New spare part				
251	New type code				

Table 5.1 Alarm/Warning Code List
(X) Dependent on parameter

Warning	yellow
Alarm	flashing red
Trip locked	yellow and red

Table 5.2 LED Indication

Bit	Hex	Dec	Alarm word	Warning word	Extended status word
0	00000001	1	Brake Check	Brake Check	Ramping
1	00000002	2	Pwr. Card Temp	Pwr. Card Temp	AMA Running
2	00000004	4	Earth Fault	Earth Fault	Start CW/CCW
3	00000008	8	Ctrl.Card Temp	Ctrl.Card Temp	Slow Down
4	00000010	16	Ctrl. Word TO	Ctrl. Word TO	Catch Up
5	00000020	32	Over Current	Over Current	Feedback High
6	00000040	64	Torque Limit	Torque Limit	Feedback Low
7	00000080	128	Motor Th Over	Motor Th Over	Output Current High
8	00000100	256	Motor ETR Over	Motor ETR Over	Output Current Low
9	00000200	512	Inverter Overld.	Inverter Overld.	Output Freq High
10	00000400	1024	DC under Volt	DC under Volt	Output Freq Low
11	00000800	2048	DC over Volt	DC over Volt	Brake Check OK
12	00001000	4096	Short Circuit	DC Voltage Low	Braking Max
13	00002000	8192	Inrush Fault	DC Voltage High	Braking
14	00004000	16384	Mains ph. Loss	Mains ph. Loss	Out of Speed Range
15	00008000	32768	AMA Not OK	No Motor	OVC Active
16	00010000	65536	Live Zero Error	Live Zero Error	-
17	00020000	131072	Internal Fault	10V Low	-
18	00040000	262144	Brake Overload	Brake Overload	-
19	00080000	524288	U phase Loss	Brake Resistor	-
20	00100000	1048576	V phase Loss	Brake IGBT	-
21	00200000	2097152	W phase Loss	Speed Limit	-
22	00400000	4194304	Fieldbus Fault	Fieldbus Fault	-
23	00800000	8388608	24 V Supply Low	24V Supply Low	-
24	01000000	16777216	Mains Failure	Mains Failure	-
25	02000000	33554432	1.8V Supply Low	Current Limit	-
26	04000000	67108864	Brake Resistor	Low Temp	-
27	08000000	134217728	Brake IGBT	Voltage Limit	-
28	10000000	268435456	Option Change	Unused	-
29	20000000	536870912	Drive Initialised	Unused	-
30	40000000	1073741824	Safe Stop	Unused	-

Table 5.3 Description of Alarm Word, Warning Word, and Extended Status Word

The alarm words, warning words, and extended status words can be read out via serial bus or optional fieldbus for diagnosis. See also *parameter 16-90 Alarm Word*, *parameter 16-92 Warning Word*, and *parameter 16-94 Ext. Status Word*.

Description of alarm word 2 and warning word 2				
Bit	Hex	Dec	Alarm word 2	Warning word 2
0	00000001	1	–	Start Delayed
1	00000002	2	–	Stop Delayed
9	00000200	512	Discharge Temperature High	Discharge Temperature High
10	00000400	1024	Start Failed	–
11	00000800	2048	Speed Limit	–

Table 5.4 Compressor Specific Alarms and Warnings

5.1.2 Alarm Words

5

Bit (hex)	Alarm word (parameter 16-90 Alarm Word)
00000001	–
00000002	Power card overtemperature
00000004	Earth fault
00000008	–
00000010	Control word timeout
00000020	Overcurrent
00000040	–
00000080	Motor thermistor overtemperature
00000100	Motor ETR overtemperature
00000200	Inverter overloaded
00000400	DC-link undervoltage
00000800	DC-link overvoltage
00001000	Short circuit
00002000	–
00004000	Mains phase loss
00008000	AMA not OK
00010000	Live zero error
00020000	Internal fault
00040000	–
00080000	Motor phase U is missing
00100000	Motor phase V is missing
00200000	Motor phase W is missing
00800000	Control voltage fault
01000000	–
02000000	VDD, supply low
04000000	Brake resistor short circuit
08000000	Brake chopper fault
10000000	Earth fault DESAT
20000000	Drive initialised
40000000	Safe Stop [A68]
80000000	–

Table 5.5 Parameter 16-90 Alarm Word

Bit (hex)	Alarm word 2 (parameter 16-91 Alarm Word 2)
00000001	–
00000002	Reserved
00000004	Service trip, typecode/sparepart
00000008	Reserved
00000010	Reserved
00000020	–
00000040	–
00000080	–
00000100	Broken belt
00000200	Not used
00000400	Not used
00000800	Reserved
00001000	Reserved
00002000	Reserved
00004000	Reserved
00008000	Reserved
00010000	Reserved
00020000	Not used
00040000	Fans error
00080000	ECB error
00100000	Reserved
00200000	Reserved
00400000	Reserved
00800000	Reserved
01000000	Reserved
02000000	Reserved
04000000	Reserved
08000000	Reserved
10000000	Reserved
20000000	Reserved
40000000	PTC 1 safe stop [A71]
80000000	Dangerous failure [A72]

Table 5.6 Parameter 16-91 Alarm Word 2

5.1.3 Warning Words

Bit (Hex)	Warning word (parameter 16-92 Warning Word)
00000001	–
00000002	Power card overtemperature
00000004	Earth fault
00000008	–
00000010	Control word timeout
00000020	Overcurrent
00000040	–
00000080	Motor thermistor overtemperature
00000100	Motor ETR overtemperature
00000200	Inverter overloaded
00000400	DC-link undervoltage
00000800	DC-link overvoltage
00001000	–
00002000	–
00004000	Mains phase loss
00008000	No motor
00010000	Live zero error
00020000	–
00040000	–
00080000	–
00100000	–
00200000	–
00400000	–
00800000	–
01000000	–
02000000	Current limit
04000000	–
08000000	–
10000000	–
20000000	–
40000000	Safe stop [W68]
80000000	Not used

Table 5.7 Parameter 16-92 Warning Word

Bit (Hex)	Warning word 2 (parameter 16-93 Warning Word 2)
00000001	–
00000002	–
00000004	Clock failure
00000008	Reserved
00000010	Reserved
00000020	–
00000040	–
00000080	End-of-curve
00000100	Broken belt
00000200	Not used
00000400	Reserved
00000800	Reserved
00001000	Reserved
00002000	Reserved
00004000	Reserved
00008000	Reserved
00010000	Reserved
00020000	Not used
00040000	Fans warning
00080000	–
00100000	Reserved
00200000	Reserved
00400000	Reserved
00800000	Reserved
01000000	Reserved
02000000	Reserved
04000000	Reserved
08000000	Reserved
10000000	Reserved
20000000	Reserved
40000000	PTC 1 safe stop [W71]
80000000	Reserved

Table 5.8 Parameter 16-93 Warning Word 2

5.1.4 Extended Status Words

5

Bit (hex)	Extended status word (parameter 16-94 Ext. Status Word)
00000001	Ramping
00000002	AMA tuning
00000004	Start CW/CCW
00000008	Not used
00000010	Not used
00000020	Feedback high
00000040	Feedback low
00000080	Output current high
00000100	Output current low
00000200	Output frequency high
00000400	Output frequency low
00000800	Brake check OK
00001000	Braking maximumm
00002000	Braking
00004000	Out of speed range
00008000	OVC active
00010000	AC brake
00020000	Password timelock
00040000	Password protection
00080000	Reference high
00100000	Reference low
00200000	Local reference/remote reference
00400000	Reserved
00800000	Reserved
01000000	Reserved
02000000	Reserved
04000000	Reserved
08000000	Reserved
10000000	Reserved
20000000	Reserved
40000000	Reserved
80000000	Reserved

Table 5.9 Parameter 16-94 Ext. Status Word

Bit (hex)	Extended status word 2 (parameter 16-95 Ext. Status Word 2)
00000001	Off
00000002	Hand/auto
00000004	Not used
00000008	Not used
00000010	Not used
00000020	Relay 123 active
00000040	Start prevented
00000080	Control ready
00000100	Drive ready
00000200	Quick stop
00000400	DC Brake
00000800	Stop
00001000	Standby
00002000	Freeze output request
00004000	Freeze output
00008000	Jog request
00010000	Jog
00020000	Start request
00040000	Start
00080000	Start applied
00100000	Start delay
00200000	Sleep
00400000	Sleep boost
00800000	Running
01000000	Bypass
02000000	Fire mode
04000000	Reserved
08000000	Reserved
10000000	Reserved
20000000	Reserved
40000000	Reserved
80000000	Reserved

Table 5.10 Parameter 16-95 Ext. Status Word 2

5.1.5 Fault Messages

WARNING 1, 10 Volts low

The 10 V voltage from terminal 50 on the control card is below 10 V.
Remove some of the load from terminal 50, as the 10 V supply is overloaded. Maximum 15 mA or minimum 590 Ω.

WARNING/ALARM 2, Live zero error

The signal on terminal 53 or 54 is less than 50% of the value set in *parameter 6-10 Terminal 53 Low Voltage*, *parameter 6-12 Terminal 53 Low Current*, *parameter 6-20 Terminal 54 Low Voltage*, or *parameter 6-22 Terminal 54 Low Current*.

WARNING/ALARM 3, No motor

No motor has been connected to the output of the frequency converter.

WARNING/ALARM 4, Mains phase loss

A phase is missing on the supply side, or the mains voltage imbalance is too high.
This message also appears in case of a fault in the input rectifier on the frequency converter.
Check the supply voltage and supply currents to the frequency converter.

WARNING 5, DC link voltage high

The intermediate circuit voltage (DC) is higher than the overvoltage limit of the control system. The frequency converter is still active.

WARNING 6, DC link voltage low

The intermediate circuit voltage (DC) is below the undervoltage limit of the control system. The frequency converter is still active.

WARNING/ALARM 7, DC over voltage

If the intermediate circuit voltage exceeds the limit, the frequency converter trips after a time.

Troubleshooting:

- Select [2] *Enable* in *parameter 2-17 Over-voltage Control*.
- Extend the ramp time.
- Activate functions in *parameter 2-10 Brake Function*.
- Increase *parameter 14-26 Trip Delay at Inverter Fault*.

Selecting OVC function extends the ramp times.

FC 103	3x200–240 V AC	3x380–500 V AC
	[V DC]	[V DC]
Undervoltage	185	373
Voltage warning low	205	410
Voltage warning high (without/with brake)	390/405	810/840
Overvoltage	410	855
The voltages stated are the intermediate circuit voltage of the frequency converter with a tolerance of ±5 %. The corresponding mains voltage is the intermediate circuit voltage (DC-link) divided by 1.35		

Table 5.11 Alarm/Warning Limits

WARNING/ALARM 8, DC under voltage

If the intermediate circuit voltage (DC) drops below the voltage warning low limit (see *Table 5.11*), the frequency converter checks if 24 V back-up supply is connected. If no 24 V backup supply is connected, the frequency converter trips after a given time depending on the unit. To check whether the supply voltage matches the frequency converter, see *General Specifications* in the *VLT® Refrigeration Drive FC 103 Design Guide*.

WARNING/ALARM 9, Inverter overloaded

The frequency converter is about to cut out because of an overload (too high current for too long). The counter for electronic, thermal inverter protection gives a warning at 98% and trips at 100%, while giving an alarm. The frequency converter cannot be reset until the counter is below 90%.
The fault is that the frequency converter is overloaded by more than nominal current for too long.

WARNING/ALARM 10, Motor ETR over temperature

According to the electronic thermal protection (ETR), the motor is too hot. Select if the frequency converter issues a warning or an alarm when the counter reaches 100% in *parameter 1-90 Motor Thermal Protection*. The fault is that the motor is overloaded by more than nominal current for too long. Check that *parameter 1-24 Motor Current* is set correctly.

WARNING/ALARM 11, Motor thermistor over temp

The thermistor or the thermistor connection is disconnected. Select if the frequency converter issues a warning or an alarm in *parameter 1-90 Motor Thermal Protection*. Check that the thermistor is connected correctly between terminal 53 or 54 (analog voltage input) and terminal 50 (+ 10 V supply), or between terminal 18 or 19 (digital input PNP only) and terminal 50. If a KTY sensor is used, check for correct connection between terminal 54 and 55.

WARNING/ALARM 12, Torque limit

The torque is higher than the value in *parameter 4-16 Torque Limit Motor Mode* (in motor operation) or the torque is higher than the value in *parameter 4-17 Torque Limit Generator Mode* (in regenerative operation).

WARNING/ALARM 13, Over Current

The inverter peak current limit (approximately 200% of the rated current) is exceeded. The warning lasts approximately 8–12 s, then the frequency converter trips and issues an alarm. Turn off the frequency converter and check if the motor shaft can be turned and if the motor size matches the frequency converter.

ALARM 14, Earth fault

There is a discharge from the output phases to ground, either in the cable between the frequency converter and the motor or in the motor itself.

Troubleshooting:

- Turn off the frequency converter and remove the ground fault.

ALARM 15, Incomplete hardware

A fitted option is not handled by the present control board (hardware or software).

ALARM 16, Short-circuit

There is short-circuiting in the motor or on the motor terminals.

Troubleshooting:

- Turn off the frequency converter and remove the short-circuit.

WARNING/ALARM 17, Control word timeout

There is no communication to the frequency converter. The warning is only active when *parameter 8-04 Control Timeout Function* is NOT set to [0] Off.

If *parameter 8-04 Control Timeout Function* is set to [5] Stop and Trip, a warning appears and the frequency converter ramps down to zero speed, while giving an alarm.

Parameter 8-03 Control Timeout Time could possibly be increased.

ALARM 18, Start Failed

The speed has not been able to exceed *parameter 1-77 Compressor Start Max Speed [RPM]* during the start within the allowed time *parameter 1-79 Compressor Start Max Time to Trip*. This may be caused by a blocked rotor.

WARNING 19, Discharge Temperature High

The discharge temperature exceeds the level programmed in *parameter 28-24 Warning Level*. If so programmed in *parameter 28-25 Warning Action*, the frequency converter lowers the speed of the compressor in an attempt to lower the discharge temperature.

ALARM 19, Discharge Temperature High

The discharge temperature exceeds the level programmed in *parameter 28-26 Emergency Level*.

WARNING 23, Internal fans

External fans have failed due to defect hardware or fans not mounted.

WARNING 24, External fan fault

The fan warning function is an extra protection function that checks if the fan is running/mounted. The fan warning can be disabled in *parameter 14-53 Fan Monitor*, [0] Disabled.

WARNING/ALARM 29, Drive over temperature

If the enclosure protection rating is IP00, IP20/Nema 1, or IP21/TYPE 1, the cutout temperature of the heat sink is 95 °C +5 °C (203 °F + 41 °F). The temperature fault cannot be reset, until the temperature of the heat sink is below 70 °C (158 °F).

The fault could be:

- Ambient temperature too high.
- Too long motor cable.

ALARM 30, Motor phase U missing

Motor phase U between the frequency converter and the motor is missing.

Troubleshooting:

- Turn off the frequency converter and check motor phase U.

ALARM 31, Motor phase V missing

Motor phase V between the frequency converter and the motor is missing.

Troubleshooting:

- Turn off the frequency converter and check motor phase V.

ALARM 32, Motor phase W missing

Motor phase W between the frequency converter and the motor is missing.

Troubleshooting:

- Turn off the frequency converter and check motor phase W.

ALARM 33, Inrush fault

Too many power-ups have occurred within a short time period. See *General Specifications* in the *VLT® Refrigeration Drive FC 103 Design Guide* for the allowed number of power-ups within 1 minute.

WARNING/ALARM 34, Fieldbus communication fault

The fieldbus on the communication option card is not working.

WARNING/ALARM 36, Mains failure

This warning/alarm is only active if the supply voltage to the frequency converter is lost and *parameter 14-10 Mains Failure* is NOT set to [0] No function.

Troubleshooting:

- Check the fuses to the frequency converter.

ALARM 38, Internal fault

Contact the local Danfoss supplier.

WARNING 40, Overload of Digital Output Terminal 27**Troubleshooting:**

- Check the load connected to terminal 27 or remove short-circuit connection.
- Check *parameter 5-00 Digital I/O Mode* and *parameter 5-01 Terminal 27 Mode*.

WARNING 41, Overload of Digital Output Terminal 29**Troubleshooting:**

- Check the load connected to terminal 29 or remove short-circuit connection.
- Check *parameter 5-00 Digital I/O Mode* and *parameter 5-02 Terminal 29 Mode*.

WARNING 42, Overload of Digital Output On X30/6**Troubleshooting:**

- Check the load connected to X30/6 or remove short-circuit connection.
- Check *parameter 5-32 Term X30/6 Digi Out (MCB 101)*.

WARNING 42, Overload of Digital Output On X30/7**Troubleshooting:**

- Check the load connected to X30/7 or remove short-circuit connection.
- Check *parameter 5-33 Term X30/7 Digi Out (MCB 101)*.

WARNING 47, 24 V supply low

The external 24 V DC back-up power supply may be overloaded, otherwise contact the Danfoss supplier.

ALARM 48, 1.8 V supply low

Contact the Danfoss supplier.

WARNING 49, Speed limit

When the speed is not within the specified range in *parameter 4-11 Motor Speed Low Limit [RPM]* and *parameter 4-13 Motor Speed High Limit [RPM]*, the frequency converter shows a warning. When the speed is below the specified limit in *parameter 1-86 Compressor Min. Speed for Trip [RPM]* (except when starting or stopping), the frequency converter trips.

ALARM 50, AMA calibration failed

Contact the Danfoss supplier.

ALARM 51, AMA check U_{nom} and I_{nom}

The setting of motor voltage, motor current, and motor power is presumably wrong.

Troubleshooting:

- Check the settings.

ALARM 52, AMA low I_{nom}

The motor current is too low.

Troubleshooting:

- Check the settings.

ALARM 53, AMA motor too big

The motor is too big for the AMA to be carried out.

ALARM 54, AMA motor too small

The motor is too small for the AMA to be carried out.

ALARM 55, AMA par. out of range

The parameter values found from the motor are outside acceptable range.

ALARM 56, AMA interrupted by user

The AMA has been interrupted by the user.

ALARM 57, AMA timeout

Try to start the AMA again a number of times, until the AMA is carried out. Note that repeated runs may heat the motor to a level where the resistance R_s and R_r are increased. In most cases, however, this is not critical.

WARNING/ALARM 58, AMA internal fault

Contact the Danfoss supplier.

WARNING 59, Current limit

The current is higher than the value in *parameter 4-18 Current Limit*.

WARNING 60, External Interlock

External interlock has been activated. To resume normal operation, apply 24 V DC to the terminal programmed for external interlock and reset the frequency converter (via bus, digital I/O, or by pressing [Reset]).

WARNING 62, Output Frequency at Maximum Limit

The output frequency is limited by the value set in *Parameter 4-19 Max Output Frequency*.

WARNING 64, Voltage Limit

The load and speed combination demands a motor voltage higher than the actual DC-link voltage.

WARNING/ALARM/TRIP 65, Control Card Over Temperature

Control card overtemperature: The cutout temperature of the control card is 80 °C (176 °F).

WARNING 66, Heatsink Temperature Low

The heat sink temperature is measured as 0 °C (32 °F). This could indicate that the temperature sensor is defective, and thus the fan speed is increased to the maximum if the power part or control card is very hot.

ALARM 67, Option Configuration has Changed

One or more options has either been added or removed since the last power-down.

ALARM 68, Safe Stop

Safe Torque Off has been activated. To resume normal operation, apply 24 V DC to terminal 37 then send a reset signal (via bus, digital I/O, or by pressing [Reset]).

ALARM 70, Illegal Frequency Converter Configuration

Actual combination of control board and power board is illegal.

ALARM 80, Drive Initialized to Default Value

Parameter settings are initialized to default setting after a manual (3-finger) reset or via *parameter 14-22 Operation Mode*.

If the temperature is below 15 °C (15 °C) the warning is present.

WARNING/ALARM 92, NoFlow

A no-flow situation has been detected for the system. See *parameter group 22-2* No-Flow Detection*.

WARNING/ALARM 93, Dry Pump

A no-flow situation and high speed indicates that the pump has run dry. See *parameter group 22-2* No-Flow Detection*.

WARNING/ALARM 94, End of Curve

Feedback stays lower than the setpoint, which may indicate a leakage in the pipe system. See *parameter group 22-5* End of Curve*.

WARNING/ALARM 95, Broken Belt

Torque is below the torque level set for no load indicating a broken belt. See *parameter group 22-6* Broken Belt Detection*.

WARNING 96, Start Delayed

Start of the motor has been delayed due to short cycle protection being active. See *parameter group 22-7* Short Cycle Protection*.

WARNING 97, Stop Delayed

Stop of the motor has been delayed due to short cycle protection being active. See *parameter group 22-7* Short Cycle Protection*.

WARNING 98, Clock Fault

Date and time has not been set or any back-up mounted has failed. See *parameter group 0-7* Clock Settings*.

ALARM 250, New Spare Part

The power or switch mode power supply has been exchanged. The frequency converter type code must be restored in the EEPROM. Select the correct type code in *parameter 14-23 Typecode Setting* according to the label on unit. Remember to select Save to EEPROM to complete.

ALARM 251, New Type Code

The frequency converter has a new type code.

Index

A

Abbreviations.....	4
AEO.....	4
see also <i>Automatic energy optimization</i>	
Alarm log.....	115
AMA.....	4
see also <i>Automatic motor adaptation</i>	
Analog output.....	84
Auto derate.....	111
Auto energy optimization compressor.....	36
Auto energy optimization VT.....	36
Automatic energy optimization.....	4
see also <i>AEO</i>	
Automatic motor adaptation.....	4
see also <i>AMA</i>	

B

Brake	
energy functions.....	54
resistor.....	4
DC brake.....	53
Break-away torque.....	6
Broken-belt detection.....	154

C

Changing parameter data.....	18
Clock settings.....	34
Coast.....	5
Coasting.....	16
Configuration.....	88
Control cables.....	11
Conventions.....	5
Cooling.....	50, 51
Current	
limit.....	4
limit control.....	109
Rated output current.....	4

D

Data log settings.....	113
Data readout.....	118
Default settings.....	22, 196
Diagnosis.....	123
Discharge time.....	8
Dry pump function.....	149

E

Efficiency.....	4
End-of-curve.....	153
Energy log.....	164
Energy savings.....	109
ETR.....	4, 119
Extended CL autotuning.....	137

F

Fault messages.....	225
FC closed loop.....	127
Feedback.....	127, 129
Fieldbus jog.....	92
Flow compensation.....	155
Freeze output.....	5
Frequency converter identification.....	116
Frequency converter status.....	119
Function set-up.....	19

G

General settings.....	36, 87
General status.....	118
Graphical display.....	13

I

I/O option.....	77
Identification, frequency converter.....	116
Indexed parameters.....	22
Initialization.....	22
Inputs	
Analog I/O mode.....	79
Analog input.....	6, 80, 82
Analog input scaling value.....	183
Digital I/O mode.....	65
Digital input.....	179
Digital inputs.....	65
Inverter switching.....	106

J

Jog.....	5
----------	---

L

Language package.....	24
LCP.....	4, 5, 7, 17, 187
see also <i>Local control panel</i>	
LCP copy/save.....	33
LCP custom readout.....	31

LCP display.....	27	PID autotuning.....	133
LED.....	13, 14	PID basic settings.....	135
Load dependent settings.....	45	PID controller.....	135
Local control panel.....	4	Port diagnostics.....	92
see also <i>LCP</i>		Potentiometer reference.....	12
Local reference.....	25, 58	Pre-lube.....	191
Log.....	114	Protection mode.....	9
Logging.....	18	Protocol.....	88
Logic rule.....	99	Pulse outputs.....	76
Low-power detection.....	148	Pulse start/stop.....	12
Low-speed detection.....	148		
M		Q	
Main menu mode.....	15, 17, 21	Quick menu mode.....	15, 17
Main menu structure.....	24		
Main reactance.....	40	R	
Mains on/off.....	106	Ramp.....	59
Mains supply.....	8	RCD.....	5, 7
Maintenance log.....	125	Reference.....	120
Manual initialization.....	23	Reference limit.....	55
MCB 109.....	180	Relay output.....	70
Modulation.....	4, 5		
Motor		S	
data.....	38	Safety precautions.....	8
limit.....	61	Serial communication.....	6
overload protection.....	50	Short cycle protection.....	155
speed, rated.....	6	Sleep mode.....	150
speed, synchronous.....	6	Software version.....	4
status.....	118	Special functions.....	106
temperature.....	49	Speed bypass.....	64
		Speed up/speed down.....	12
N		Start adjustments.....	46
Night speed drop override.....	189	Start delay.....	46
No-flow detection.....	145	Start function.....	46
		Start/stop.....	11
O		Stator leakage reactance.....	40
Operating data.....	113	Status.....	15
Operating mode.....	25	Status message.....	13
Overload		Stop adjustments.....	49
Inverter overload, no trip.....	111	Symbols.....	4
P			
Parameter data.....	17	T	
Parameter information.....	117	Thermal load.....	44, 119
Parameter options.....	196	Thermistor.....	7, 50
Parameter selection.....	21	Timed actions.....	159
Parameter set-up.....	17	Timer.....	99
Password.....	34		
PELV.....	5		

Torque
 Constant torque..... 4
 limit..... 5
 Variable torque..... 5
Trip reset..... 107

V

Voltage
 reference via a potentiometer..... 12
VVC+..... 5, 8



.....
Danfoss can accept no responsibility for possible errors in catalogues, brochures and other printed material. Danfoss reserves the right to alter its products without notice. This also applies to products already on order provided that such alterations can be made without subsequential changes being necessary in specifications already agreed. All trademarks in this material are property of the respective companies. Danfoss and the Danfoss logotype are trademarks of Danfoss A/S. All rights reserved.
.....

Danfoss A/S
Ulsnaes 1
DK-6300 Graasten
vlt-drives.danfoss.com

