

Installation Instruction: MCD Profibus Module

Order Code: 175G9001

1. Important User Information

Observe all necessary safety precautions when controlling the soft starter remotely. Alert personnel that machinery may start without warning.

It is the installer's responsibility to follow all instructions in this manual and to follow correct electrical practice.

2. Installation



CAUTION

Remove mains and control voltage from the soft starter before attaching or removing accessories. Failure to do so may damage the equipment.

1. Remove control power and mains supply from the soft starter.
2. Attach the module to the soft starter as illustrated.
3. Set the module address to match the address set in the Master configuration tool.
4. Apply control power to the soft starter.
5. Insert the network connector and power up the module.

2.2. Physical Installation

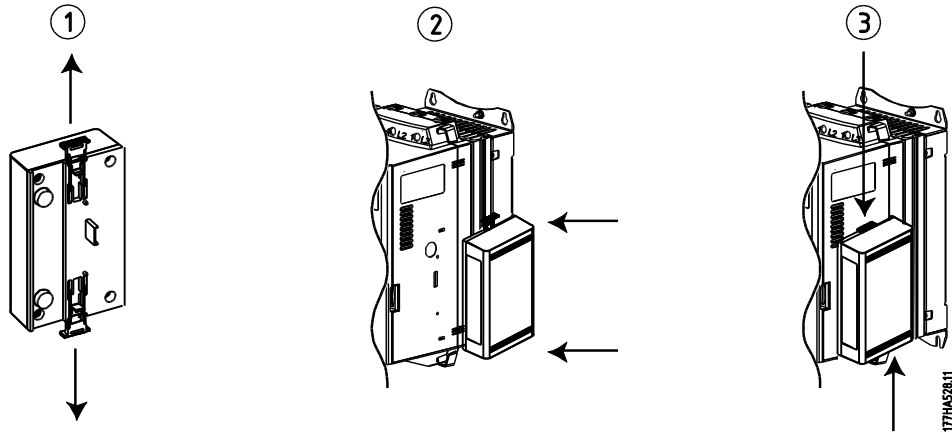
1. Fully pull out the top and bottom retaining clips on the module.
2. Line up the module with the comms port slot.
3. Push in the top and bottom retaining clips to secure the module to the starter.



Remove the Profibus Module using the following procedure:

1. Remove control power and mains supply from the soft starter.
2. Disconnect all field wiring from the module.
3. Fully pull out the top and bottom retaining clips on the module.
4. Pull the module away from the soft starter.

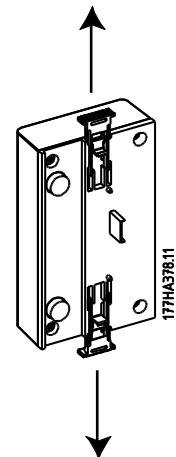

3. Configuration

Import the latest .gsd file into your Master configuration tool. This file is available from www.danfoss.com/drives.

If your Master uses on-screen icons, two graphic bitmap files are available from the website. SSPM_N.bmp indicates normal mode. SSPM_D.bmp indicates diagnostic mode.



N.B.!:

The Profibus Module has a slave address range of 0 to 99.

If the Profibus network fails, the module will leave data exchange mode after the network watchdog timeout period has expired. This timeout period is set at the Master configuration tool.

A Communication Timeout parameter in the GSD file sets how soon after this event the soft starter will be forced into a trip state.

The user can adjust the Communication Timeout parameter in the GSD file to any setting between 0 and 100 seconds. The default setting is 10 seconds.



N.B.!:

If the Communication Timeout parameter is set to 0, the current state of the soft starter will remain unchanged on a network failure. This gives the user the option of operating the soft starter via local control, but is NOT failsafe.

4. Adjustment

Before powering up the Profibus Module, set the two rotary switches so that the module address matches the address set in your Master configuration tool (the diagram shows the factory default setting for the rotary switches).

The module automatically detects the network data rate.

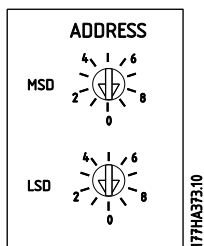

5. Connection

The module connects to the Profibus network via a standard 9-pin Sub-D connector.

The Profibus Module can be powered either through the network cable or externally (24 VDC).

MCD 200: For the Profibus Module to accept serial commands, a link must be fitted across terminals A1-N2 on the soft starter.

In order for the MCD 500 to accept commands from the serial network, the soft starter must be in Auto On mode and links must be fitted to terminals 17, 18 and 25, 18.

In Hand On mode, the starter will not accept commands from the serial network but the starter's status can still be monitored.

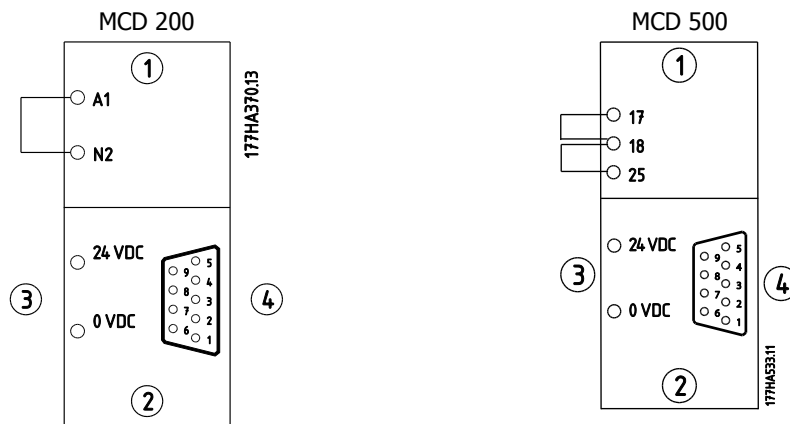

①	MCD 200	①	MCD 500 (Auto On mode) 17, 18: Stop 25, 18: Reset
②	Profibus Module	②	Profibus Module
③	External 24 VDC supply required if not powered through bus	③	External 24 VDC supply required if not powered through bus
④	9-pin Sub-D connector to Profibus network	④	9-pin Sub-D connector to Profibus network

9-pin Sub-D connector

Pin No.	Assignment
1	Shield
2	24 VDC negative (optional)
3	RxD/TxD-P
4	Not used
5	DGND
6	VP (end of bus slave only)
7	24 VDC positive (optional)
8	RxD/TxD/-N
9	DGND



N.B.!:

If MCD 500 parameter 3-2 *Comms in Remote* is set to Disable Comms in Remote, the starter will not accept start or stop commands from the serial network (the starter will still accept reset commands and allow status monitoring).

6. Power Status LED (Red) and Bus Status LED (Green)

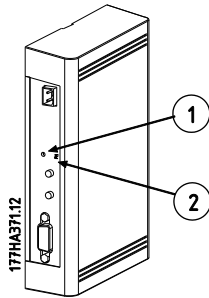

		OFF	ON
①	Power status (red)	Module not powered up	Module powered up and ready to go online
②	Bus status (green)	No connection, offline or data exchange failure	Module online and in data exchange state



N.B.!:

If communication fails between the module and the network, the Bus Status LED will go off. When communication is restored, the Bus Status LED will come back on.



N.B.!:

When a communications failure occurs, the soft starter may trip if the Communication Timeout parameter for the network is set greater than zero. When communication is restored, the soft starter must be reset.

7. Data Structures

The GSD file contains three operating modules, supporting data I/O structures as follows:

Data Structure	Basic Module	Extended Module	Parameter Upload/Download Module
Soft Starter Control I/O on page 5	✓	✓	✓
Soft Starter Monitoring I/O on page 6	✗	✓	✓
Soft Starter Programming I/O on page 9	✗	✗	✓

The Basic Module allows the user to start and stop the soft starter and read limited information on operating status.

The Extended Module defines additional bytes allowing the user to read soft starter operating data such as actual motor current and motor temperature.

The Parameter Upload/Download Module allows the user to read and write soft starter parameter values (only applicable to MCD 500 soft starters).

8. Soft Starter Control I/O Data Structure

Master > Slave control word is structured as follows:

Byte 0							
Bit 7	Bit 6	Bit 5	Bit 4	Bit 3	Bit 2	Bit 1	Bit 0
<i>Reserved</i>	<i>Reserved</i>	<i>Reserved</i>	Quick stop	Motor set		<i>Reserved</i>	<i>Reserved</i>
Byte 1							
Bit 7	Bit 6	Bit 5	Bit 4	Bit 3	Bit 2	Bit 1	Bit 0
<i>Reserved</i>	<i>Reserved</i>	<i>Reserved</i>	<i>Reserved</i>	Reset	<i>Reserved</i>	<i>Reserved</i>	Fwd run

8.1. Quick stop bit

When Fwd run bit changes from 1 to 0:

0 = stop action will be a soft stop (as selected on the soft starter).

1 = stop action will be a quick stop (i.e. coast to stop).



N.B.!

The Quick stop bit must be set to 0 before the soft starter can perform a start.

8.2. Motor set bits

Selects which parameter set to use when starting:

0 = selected from soft starter remote input (programmable input must be set to 'Motor Set Select')

1 = soft starter primary motor set (ensure soft starter programmable input is not set to 'Motor Set Select')

2 = soft starter secondary motor set (ensure soft starter programmable input is not set to 'Motor Set Select')

3 = *Reserved*

Slave > Master status word is structured as follows:

Byte 0							
Bit 7	Bit 6	Bit 5	Bit 4	Bit 3	Bit 2	Bit 1	Bit 0
Ramping	Hand On	Motor current (% FLC) ¹					
Byte 1							
Bit 7	Bit 6	Bit 5	Bit 4	Bit 3	Bit 2	Bit 1	Bit 0
<i>Reserved</i>	<i>Reserved</i>	<i>Reserved</i>	<i>Reserved</i>	Warning	Fault	On	Ready

¹ Motor current (% FLC) represents current as a percentage of the set motor full load current. A maximum value of 63 represents 200% full load current. To convert this value to a readable percentage, divide by 0.315.

Ready is set when the soft starter is ready to start the motor.

On is set when the soft starter is starting, running or soft stopping the motor.

Warning is set when the soft starter detects a warning condition.

Fault is set when the soft starter has tripped.

Ramping is set when the soft starter is starting or soft stopping the motor.

Hand On is set when the soft starter is set to Hand On mode.

9. Soft Starter Monitoring I/O Data Structure

Master > Slave output byte is structured as follows:

Byte 2
Operating data request (Data request numbers 1 to 14)

Slave > Master input bytes, in response to an operating data request, are structured as follows:

Byte 2
Echo data request number
Byte 3
Bits 7 to 1 <i>Reserved</i> Bit 0 = 1: Invalid data request number
Byte 4
Data value - high byte
Byte 5
Data value - low byte



N.B.!:

An invalid data request number will result in the invalid data request number bit being set = 1.

Data values are defined as follows:

Data Request Number	Data Value High Byte	Data Value Low Byte
0	<i>Reserved</i>	
1	Soft starter product type code ¹	Soft starter software version number
2	Trip/Warning code	Soft starter status
3 ²	Average current (high byte)	Average current (low byte)
4 ³	Motor 2 temperature	Motor 1 temperature
5	<i>Reserved</i>	Percentage power factor
6	Power (kW)	
7	Power (kVA)	
8	Average voltage	
9 ²	L1 current	
10	L2 current	
11	L3 current	
12	L1 voltage	
13	L2 voltage	
14	L3 voltage	
15	Software major version number	Software minor revision number
16	<i>Reserved</i>	Digital input state

¹ Product type code:

- 4 = MCD 200
- 7 = MCD 500

² For models MCD5-0428C and smaller this value will be 10 times greater than the value displayed on the LCP.

³ Motor temperature is calculated using the soft starter thermal modelling.



N.B.!:

Data request numbers 5 to 11 are only valid for MCD 500 starters. MCD 200 starters will return zero values.

9.1. Soft starter status

The low byte data value of data request number 2 reports soft starter status.

Bits 0 to 3 function as follows:

Value (decimal) Bits 0 to 3	Soft Starter Status
0	Unknown (communication error between module and soft starter)
1	Ready to start (waiting)
2	Starting (soft starting)
3	Running (running – full voltage at the motor)
4	Stopping (soft stopping)
5	Not ready (restart or thermal delay and Run simulation)
6	Fault (tripped)
7 ¹	Menu or Logs Menu open
8 ¹	Jog Forward (slow speed)
9 ¹	Jog Reverse (slow speed)

¹ Only available on MCD 500 soft starters.

Bits 4 to 7 function as follows:

Bit Number	Function
Bit 4	Set if positive phase sequence detected (Bit 6 must = 1)
Bit 5	Set if average current exceeds Motor FLC setting
Bit 6	Set after first start once phase sequence has been confirmed
Bit 7	Set if a communication failure occurs between module and soft starter

9.2. Power

Input bytes for data request numbers 6 and 7 are defined as follows:

	Bit 7	Bit 6	Bit 5	Bit 4	Bit 3	Bit 2	Bit 1	Bit 0
High Byte	Power scale factor				Power high nibble			
Low Byte	Power low byte							

Powerscale functions as follows:

- 0 = multiply Power by 10 to get W
- 1 = multiply Power by 100 to get W
- 2 = Power is represented in kW
- 3 = multiply Power by 10 to get kW

9.3. Digital Input State

The low byte of data request number 16 reports digital input state as follows (0 = open, 1 = closed):

	Bit 7	Bit 6	Bit 5	Bit 4	Bit 3	Bit 2	Bit 1	Bit 0
Low Byte	<i>Reserved</i>				Input A	Reset	Stop	Start

9.4. Trip Codes

Data request number 2 high byte indicates the soft starter trip or warning code. Details are as follows:

Trip Code	Trip Type	MCD 201	MCD 202	MCD 500
1	Excess start time		■	■
2	Motor overload (thermal model)		■	■
3	Motor thermistor		■	■
4	Current imbalance		■	■
5	Frequency (Mains supply)	■	■	■
6	Phase sequence		■	■
7	Instantaneous overcurrent			■
8	Power loss/Power circuit	■	■	■
9	Undercurrent			■
10	Heatsink overtemperature			■
11	Motor connection			■
12	Input A trip			■
13	FLC too high (FLC out of range)			■
14	Unsupported option (function not available in inside delta)			■
15	Starter communication (between module and soft starter)	■	■	■
16	Network communication (between module and network)	■	■	■
17	Internal fault x (where x is the fault code detailed in the table below).			■
23	Parameter out of Range			■
25	Bypass fail (bypass contactor)			■
26	L1 phase loss			■
27	L2 phase loss			■
28	L3 phase loss			■
29	L1-T1 shorted			■
30	L2-T2 shorted			■
31	L3-T3 shorted			■
33★	Time-overcurrent (Bypass overload)		■	■
35	Battery/clock			■
36	Thermistor circuit			■
255	No trip	■	■	■

★ For MCD 500, time-overcurrent protection is only available on internally bypassed models.

9.4.1. Internal Fault x

The table below details the internal fault code associated with trip code 17.

Internal fault	Message displayed on the LCP
70, 71, 72	Current Read Err Lx
73	Power On in Simulation mode
74, 75, 76	Motor connection Tx
77, 78, 79	Firing fail SCRx
80, 81, 82	VZC Fail Px
83	Low Control Volts
84 to 98	Internal fault X Contact your local supplier with the fault code (X).

10. Soft Starter Programming I/O Data Structure

The Soft Starter Programming I/O Data Structure allows the user to upload (read) and download (write) soft starter parameter values over the network.

Master > Slave output bytes are structured as follows.

	Bit 7	Bit 6	Bit 5	Bit 4	Bit 3	Bit 2	Bit 1	Bit 0
Byte 3	Parameter number to read/write							
Byte 4	<i>Reserved</i>	<i>Reserved</i>	<i>Reserved</i>	<i>Reserved</i>	<i>Reserved</i>	Write parameter	Read parameter	<i>Reserved</i>
Byte 5	High byte parameter value to write to soft starter/ zero data values for read							
Byte 6	Low byte parameter value to write to soft starter/ zero data values for read							

Slave > Master input bytes are structured as follows.

	Bit 7	Bit 6	Bit 5	Bit 4	Bit 3	Bit 2	Bit 1	Bit 0
Byte 6	Echo parameter number							
Byte 7	<i>Reserved</i>	<i>Reserved</i>	<i>Reserved</i>	Parameter access level	Write access denied	Invalid parameter value	Invalid parameter number	
Byte 8	High byte parameter value read from soft starter							
Byte 9	Low byte parameter value read from soft starter							

Parameter access level is defined as follows:

- 0 = Read only
- 1 = Operator (MCD 500 parameter groups 1 to 8)
- 2 = Supervisor (MCD 500 parameter groups 15 and 16)
- 3 = Commissioning (MCD 500 parameter group 20)



N.B.!:

This operating module only functions with MCD 500 soft starters.

11. Profibus Diagnostic Telegram and Flag

The Profibus Module supports external diagnostics. The following telegram will be sent to the Master if the soft starter trips or if a parameter is changed at the soft starter.

Diagnostic Telegram Data Structure	
Byte 0	User diagnostic length (Always set = 3)
Byte 1	Trip code
Byte 2	Changed parameter number (MCD 500 only)

11.1. Profibus Trip Code

When the soft starter trips, a diagnostic flag is set at the Master and the trip code is reported in Byte 1. When the soft starter is reset, the diagnostic flag and trip code data are reset = 0, provided the trip condition does not still exist (see *Soft Starter Monitoring I/O Data Structure* on page 6 for trip codes).

11.2. Changed Parameter Number

If a parameter is changed via the LCP, the affected parameter number is reported in Byte 2. When the Master reads or writes the changed parameter, Byte 2 is reset = 0.

A changed parameter number does not set a diagnostic flag.

12. Profibus Freeze Mode

The Profibus Module supports Freeze Mode.

In Freeze Mode, inputs are only updated with new data from the soft starter when another Freeze action is carried out. An Un-Freeze action returns the Profibus Module to normal operation.

13. Profibus Sync Mode

The Profibus Module supports Sync Mode.

In Sync Mode, commands to the soft starter are not processed until another Sync action is carried out. An Un-Sync action returns the Profibus Module to normal operation.

14. Profibus Clear Mode

If the Master sends a global Clear command, the Profibus Module will send a Quick Stop command to the soft starter.

15. Specifications

Enclosure

Dimensions 40 mm (W) x 166 mm (H) x 90 mm (D)
 Weight 250 g
 Protection IP20

Mounting

Spring-action plastic mounting clips (x 2)

Connections

Soft starter 6-way pin assembly
 Contacts Gold flash
 Network DB9 female
 External power supply 2-way removable screw type
 Maximum cable size 2.5 mm²

Settings

Network address
 Setting MSD and LSD rotary switches
 Range 0 to 99
 Data rate
 Setting Auto-detect
 Range 9.6 kb/s ~ 12.0 Mb/s

Power

Consumption (steady state, maximum) 35 mA at 24 VDC
 Reverse polarity protected
 Galvanically isolated

Certification

C✓ IEC 60947-4-2
 CE IEC 60947-4-2
 Profibus International



