

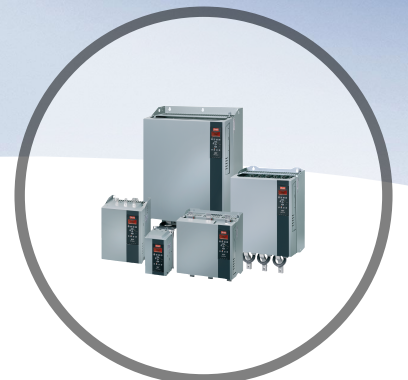

Operating Guide EtherNet/IP Module

VLT® Compact Starter MCD 201/MCD 202

VLT® Soft Starter MCD 500



Contents

1 Introduction	3
1.1 Purpose of the Manual	3
1.2 Additional Resources	3
1.3 Product Overview	3
1.4 Approvals and Certifications	3
1.5 Disposal	3
1.6 Symbols, Abbreviations, and Conventions	4
2 Safety	5
3 Installation	7
3.1 Installation Procedure	7
4 Connection	8
4.1 Soft Starter Connection	8
4.2 Network Connection	8
4.2.1 Ethernet Ports	8
4.2.2 Cables	8
4.2.3 EMC Precautions	9
4.2.4 Network Establishment	9
4.3 Addressing	9
5 Device Configuration	10
5.1 Configuration Overview	10
5.2 On-board Web Server	10
5.3 Ethernet Device Configuration Tool	10
6 Operation	12
6.1 Scanner Configuration	12
6.1.1 EDS File	12
6.2 LEDs	12
7 Packet Structures	13
7.1 Ensuring Safe and Successful Control	13
7.2 Cyclic Operation	13
7.2.1 Assembly Objects	13
7.2.2 Control Commands	13
7.2.2.1 Receiving Control Data from the Controller	13
7.2.2.2 Control Word (Write-only)	13
7.2.2.3 Command Examples	14
7.2.3 Status Information	14

7.2.3.1 Reading Status Information from the Soft Starter	14
7.2.3.2 Status Word (Read-only)	15
7.2.3.3 Trip Codes	15
7.3 Acyclic Operation	16
7.3.1 Class 0X01 Identity Object	16
7.3.2 Vendor-specific Objects	16
7.3.2.1 Class 100 Objects (Read/Write)	16
7.3.2.2 Class 101 Objects (Read/Write)	17
7.3.2.3 Class 103 Objects (Read-only)	17
7.3.2.4 Class 104 Objects (Read-only)	18
7.3.3 Supported Services for Vendor-specific Objects	18
7.3.3.1 Set Attribute Single	18
7.3.3.2 Get Attribute Single	19
7.3.3.3 Status Codes for Acyclic Services	20
8 Network Design	21
8.1 Star Topology	21
8.2 Line Topology	21
8.3 Ring Topology	21
8.4 Combined Topologies	22
9 Specifications	23
Index	24

1 Introduction

1.1 Purpose of the Manual

This installation guide provides information for the installation of the EtherNet/IP option module for VLT® Compact Starter MCD 201/MCD 202 and VLT® Soft Starter MCD 500. The installation guide is intended for use by qualified personnel. Users are assumed to be familiar with:

- VLT® soft starters.
- EtherNet/IP technology.
- PC or PLC that is used as a master in the system.

Read the instructions before installation and ensure that the instructions for safe installation are observed.

VLT® is a registered trademark.

EtherNet/IP™ is a trademark of ODVA, Inc.

1.2 Additional Resources

Resources available for the soft starter and optional equipment:

- The *VLT® Compact Starter MCD 200 Operating Instructions* provide the necessary information for getting the soft starter up and running.
- The *VLT® Soft Starter MCD 500 Operating Guide* provides the necessary information for getting the soft starter up and running.

Supplementary publications and manuals are available from Danfoss. See drives.danfoss.com/knowledge-center/technical-documentation/ for listings.

1.3 Product Overview

1.3.1 Intended Use

This installation guide relates to EtherNet/IP Module for VLT® soft starters.

The EtherNet/IP interface is designed to communicate with any system complying with the CIP EtherNet/IP standard. EtherNet/IP provides users with the network tools to deploy standard Ethernet technology for manufacturing applications while enabling internet and enterprise connectivity.

EtherNet/IP Module is intended for use with:

- VLT® Compact Starter MCD 201/MCD 202, 24 V AC/V DC and 110/240 V AC control voltage.
- VLT® Soft Starter MCD 500, all models.

NOTICE

The EtherNet/IP Module is NOT suitable for use with the MCD 201/MCD 202 compact starters using 380/440 V AC control voltage.

NOTICE

LOSS OF WARRANTY

The EtherNet/IP Module supports a field update function for its internal software. This function is for authorized service personnel only. Misuse may cause permanent failure of the module. Unauthorized use voids the product warranty.

The EtherNet/IP Module allows a Danfoss soft starter to connect to an Ethernet network and be controlled or monitored using an Ethernet communication model.

The EtherNet/IP Module operates at the application layer.

Familiarity with Ethernet protocols and networks is required to operate the EtherNet/IP Module successfully. In case of difficulties when using this device with third-party products, including PLCs, scanners, and commissioning tools, contact the relevant supplier.

1.4 Approvals and Certifications



More approvals and certifications are available. For more information, contact a local Danfoss partner.

1.5 Disposal

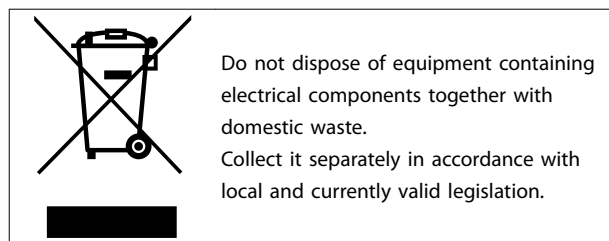

1.6 Symbols, Abbreviations, and Conventions

Abbreviation	Definition
CIP™	Common industrial protocol
DHCP	Dynamic host configuration protocol
EMC	Electromagnetic compatibility
IP	Internet protocol
LCP	Local control panel
LED	Light-emitting diode
PC	Personal computer
PLC	Programmable logic controller

Table 1.1 Symbols and Abbreviations

Conventions

Numbered lists indicate procedures.

Bullet lists indicate other information and description of illustrations.

Italicized text indicates:

- Cross-reference.
- Link.
- Parameter name.
- Parameter group name.
- Parameter option.

2 Safety

The following symbols are used in this manual:

⚠ WARNING

Indicates a potentially hazardous situation that could result in death or serious injury.

⚠ CAUTION

Indicates a potentially hazardous situation that could result in minor or moderate injury. It can also be used to alert against unsafe practices.

NOTICE

Indicates important information, including situations that can result in damage to equipment or property.

The examples and diagrams in this manual are included solely for illustrative purposes. The information contained in this manual is subject to change at any time and without prior notice. Responsibility or liability is never accepted for direct, indirect, or consequential damage resulting from the use or application of this equipment.

NOTICE

Before changing any parameter settings, save the current parameter to a file using MCD PC Software or the *Save User Set* function.

⚠ WARNING

ELECTRICAL SHOCK HAZARD

VLT® Soft Starters MCD 500 contain dangerous voltages when connected to mains voltage. Only a qualified electrician should carry out the electrical installation. Improper installation of the motor or the soft starter can cause equipment failure, serious injury, or death. Follow the guidelines in this manual and local electrical safety codes.

Models MCD5-0360C ~ MCD5-1600C:

Treat the busbar and heat sink as live parts whenever the unit has mains voltage connected (including when the soft starter is tripped or waiting for a command).

⚠ WARNING

PROPER GROUNDING

Disconnect the soft starter from mains voltage before carrying out repair work.

It is the responsibility of the person installing the soft starter to provide proper grounding and branch circuit protection according to local electrical safety codes.

Do not connect power factor correction capacitors to the output of the VLT® Soft Starter MCD 500. If static power factor correction is employed, it must be connected to the supply side of the soft starter.

⚠ WARNING

IMMEDIATE START

In auto-on mode, the motor can be controlled remotely (via remote inputs) while the soft starter is connected to mains.

MCD5-0021B ~ MCD5-961B:

Transportation, mechanical shock, or rough handling may cause the bypass contactor to latch into the On state. To prevent the motor from starting immediately on first commissioning or operation after transportation, always ensure that the control supply is applied before the power. Applying control supply before power ensures that the contactor state is initialized.

⚠ WARNING

SAFETY OF PERSONNEL

The soft starter is not a safety device and does not provide electrical isolation or disconnection from the supply.

- If isolation is required, the soft starter must be installed with a main contactor.
- Do not rely on the start and stop functions for safety of personnel. Faults occurring in the mains supply, the motor connection, or the electronics of the soft starter can cause unintended motor starts or stops.
- If faults occur in the electronics of the soft starter, a stopped motor may start. A temporary fault in the supply mains or loss of motor connection can also cause a stopped motor to start.

To provide safety of personnel and equipment, control the isolation device through an external safety system.

NOTICE

Use the *auto-start* feature with caution. Read all the notes related to *auto-start* before operation.

2

3 Installation

3.1 Installation Procedure

CAUTION
EQUIPMENT DAMAGE

Remove mains and control voltage from the soft starter before attaching or removing accessories. Failure to do so may damage the equipment.

Installing the EtherNet/IP option:

1. Remove control power and mains supply from the soft starter.
2. Fully pull out the top and bottom retaining clips on the module (A).
3. Line up the module with the communication port slot (B).
4. Push in the top and bottom retaining clips to secure the module to the soft starter (C).
5. Connect Ethernet port 1 or port 2 on the module to the network.
6. Apply control power to the soft starter.

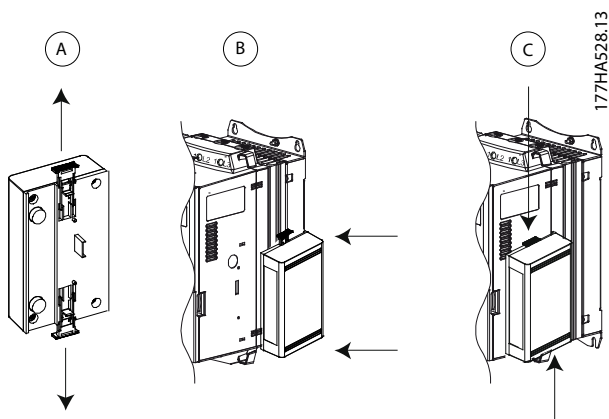

Illustration 3.1 Installing the EtherNet/IP Option

Remove the module from the soft starter:

1. Remove control power and mains supply from the soft starter.
2. Disconnect all external wiring from the module.
3. Fully pull out the top and bottom retaining clips on the module (A).
4. Pull the module away from the soft starter.

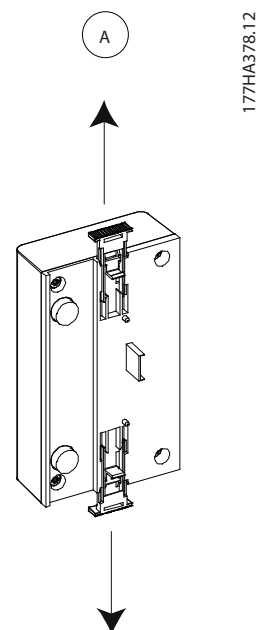

Illustration 3.2 Removing the EtherNet/IP Option

4 Connection

4.1 Soft Starter Connection

The EtherNet/IP Module is powered from the soft starter.

VLT® Compact Starter MCD 201/MCD 202

For the EtherNet/IP Module to accept fieldbus commands, fit a link across terminals N1–N2 on the soft starter.

VLT® Soft Starter MCD 500

If the MCD 500 has to be operated in reset mode, input links are required across terminals 17 and 25 to 18. In hand-on mode, links are not required.

EtherNet/IP Module Connections

NOTICE

FOR MCD 500 ONLY

Control via the fieldbus communication network is always enabled in local control mode and can be enabled or disabled in remote control mode (*parameter 3-2 Comms in Remote*). See the relevant soft starter *operating guide* for parameter details.

MCD 201/202		MCD 500	
1	N1, N2: Stop input	1	(Auto-on mode) 17, 18: Stop input 25, 18: Reset input
2	EtherNet/IP Module	2	EtherNet/IP Module
3	RJ45 Ethernet ports	3	RJ45 Ethernet ports

Table 4.1 Connection Diagrams

4.2 Network Connection

4.2.1 Ethernet Ports

The EtherNet/IP Module has 2 Ethernet ports. If only 1 connection is required, either port can be used.

4.2.2 Cables

Suitable cables for EtherNet/IP Module connection:

- Category 5
- Category 5e
- Category 6
- Category 6e

4.2.3 EMC Precautions

To minimize electromagnetic interference, Ethernet cables should be separated from motor and mains cables by 200 mm (7.9 in).

The Ethernet cable must cross the motor and mains cables at an angle of 90°.

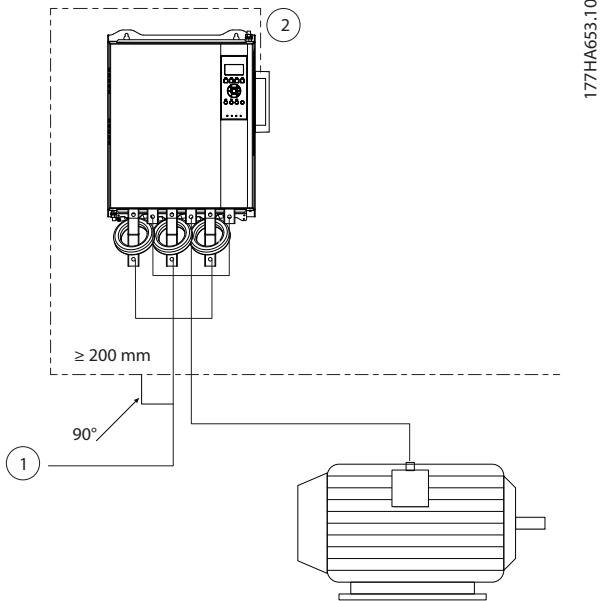

1	3-phase supply
2	Ethernet cable

Illustration 4.1 Correct Running of Ethernet Cables

4.2.4 Network Establishment

The controller must establish communication directly with each device before the device can participate in the network.

4.3 Addressing

Each device in a network is addressed using a MAC address and an IP address and can be assigned a symbolic name associated with the MAC address.

- The factory default is a static IP address (192.168.1.2). The module also supports BootP and DHCP addressing.
- The symbolic name is optional and must be configured within the device.
- The MAC address is fixed within the device and is printed on a label on the front of the module.

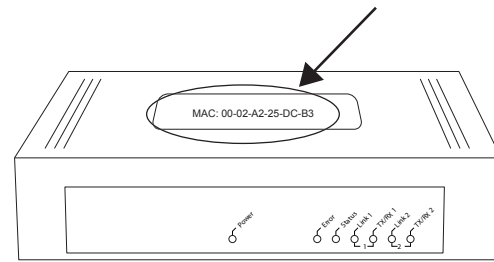

Illustration 4.2 MAC ID Location

5 Device Configuration

5.1 Configuration Overview

The EtherNet/IP Module is configured with a static IP address as default. To avoid IP address conflict and to ensure successful employment, connect the module directly to a PC or laptop to configure the IP address before connecting to the network. To configure the IP address, or to enable BootP or DHCP addressing, use the on-board web server.

NOTICE

The error LED flashes whenever the device is receiving power but is not connected to a network. The error LED flashes throughout the configuration process.

5.2 On-board Web Server

Ethernet attributes can be configured directly in the EtherNet/IP Module using the on-board web server.

NOTICE

The web server only accepts connections from within the same subnet domain.

To configure the device using the on-board web server:

1. Attach the module to a soft starter.
2. Connect Ethernet port 1 or port 2 on the module to the network.
3. Apply control power to the soft starter.
4. Start a browser on the PC and enter the device address, followed by /ipconfig. The default address for a new EtherNet/IP Module is 192.168.1.2.

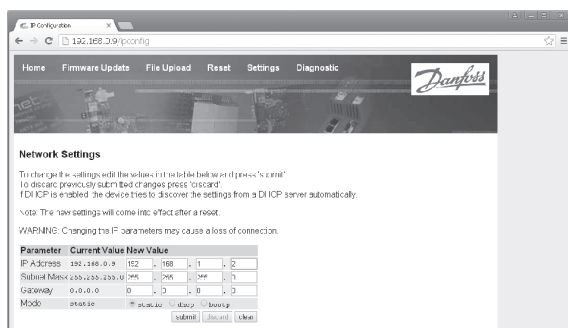

Illustration 5.1 Entering Network Settings

5. Edit the settings as required.
6. Click *Submit* to save the new settings.

7. If prompted, enter username and password.

7a Username: danfoss

7b Password: danfoss

NOTICE

If an IP address is changed and the record of it is lost, use the Ethernet Device Configuration Tool to scan the network and identify the module.

NOTICE

If changing the subnet mask, the server is unable to communicate with the module after the new settings are saved.

5.3 Ethernet Device Configuration Tool

If the IP address is unknown, or if the subnet mask of the web server does not match, use the Ethernet Device Configuration Tool to connect to the EtherNet/IP Module.

Changes made via the Ethernet Device Configuration Tool cannot be stored permanently in the module and are lost when control power is cycled. Use the Ethernet Device Configuration Tool to change the IP address settings temporarily, then use the new address to connect to the module using the on-board web server to save the settings permanently.

Download the Ethernet Device Configuration Tool. To install the software, administrator privileges are required on the PC.

Downloading the tool:

1. Go to drives.danfoss.com/services/pc-tools to find the tool.
2. Make sure to have administrator privileges on the PC before starting the installation.
3. Accept the End-User License Agreement.
4. Click Yes on the User account control dialog box.

NOTICE

If the PC has a firewall enabled, add the tool to the list of authorized programs.

Configuring the device using the Ethernet Device Configuration Tool:

1. Attach the module to a soft starter.
2. Connect Ethernet port 1 or port 2 on the module to the network.
3. Apply control power to the soft starter.

4. Start the Ethernet Device Configuration Tool.

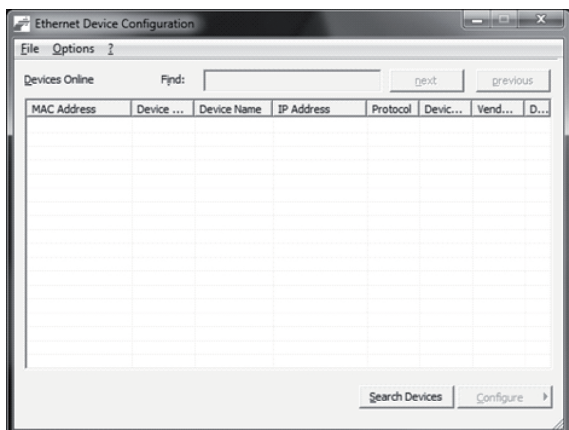

177HA623.10

Illustration 5.2 Starting the Tool

6. To set a static IP address, click *Configure* and select *Set IP address*.

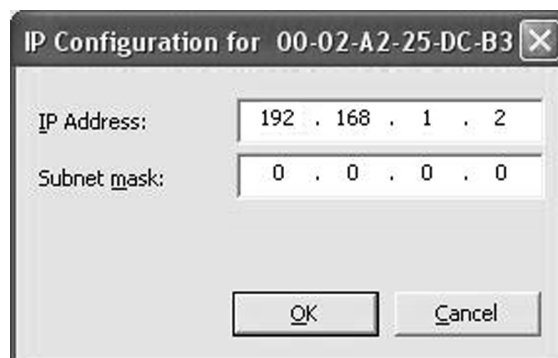

177HA642.10

Illustration 5.4 Setting a Static IP Address

5. Click *Search Devices*.
 - 5a The software searches for connected devices.

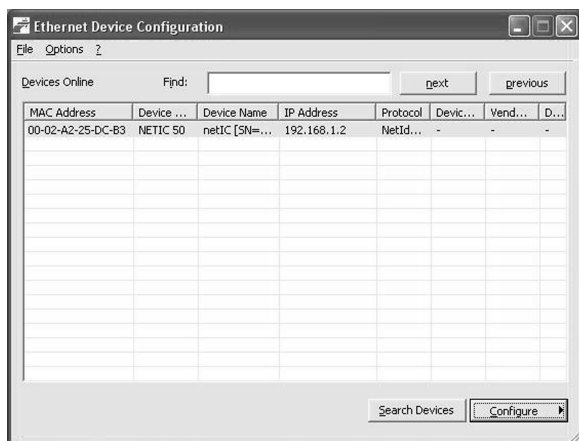

177HA641.10

Illustration 5.3 The Tool Shows the Connected Devices

6 Operation

The EtherNet/IP Module is conformance tested to ODVA. For successful operation, the scanner must also support all functions and interfaces described in this manual.

6.1 Scanner Configuration

6.1.1 EDS File

Download the EDS file from drives.danfoss.com/services/pc-tools. The EDS file contains all required attributes of the EtherNet/IP Module.

Once the EDS file is loaded, the individual EtherNet/IP Module must be defined.

6.2 LEDs

6

LED name	LED status	Description
Power	Off	The module is not powered up.
	On	The module receives power.
Error	Off	The module is not powered up or does not have an IP address.
	Flashing	Connection timeout.
	On	Duplicate IP address.
Status	Off	The module is not powered up or does not have an IP address
	Flashing	The module has obtained an IP address but has not established any network connections.
	On	Communication has been established.
Link x	Off	No network connection.
	On	Connected to a network.
TX/RX x	Flashing	Transmitting or receiving data.

Table 6.1 Feedback LEDs

7 Packet Structures

7.1 Ensuring Safe and Successful Control

Data written to the EtherNet/IP Module remains in its register until the data is overwritten or the module is reinitialized. The EtherNet/IP Module does not transfer successive duplicate commands to the soft starter.

- If the soft starter is started via fieldbus communication but stopped via the LCP or a remote input, an identical start command cannot be used to restart the soft starter.
- If the soft starter is controlled via the LCP or the remote inputs (and via fieldbus communications), a control command should be immediately followed by a status query to confirm that the command has been actioned.

NOTICE

Functions available only in VLT® Soft Starter MCD 500:

- Parameter management
- Dual motor control
- Digital inputs
- Jog
- Current measurement in amperes
- Power information
- Warnings

NOTICE

VLT® Compact Starter MCD 201 open-loop soft starters do not support motor current and motor temperature information.

7.2 Cyclic Operation

This section lists requirements related to cyclic services for the EtherNet/IP Module. The EtherNet/IP Module uses both implicit (I/O) and explicit messaging, with a cyclic trigger (minimum cyclic interval = 1 ms).

7.2.1 Assembly Objects

The EtherNet/IP Module supports the assembly objects listed in *Table 7.1*.

Assembly instances	Description	Maximum size	Type
104	Originator→target	2 (4) bytes	Integer
154	Target→originator	6 (12) bytes	Integer

Table 7.1 Assembly Objects

7.2.2 Control Commands

7.2.2.1 Receiving Control Data from the Controller

The EtherNet/IP Module uses output assembly instance 104d in assembly class 0x04 to receive control data from the controller. This is the only valid assembly instance.

Byte	Function ¹⁾	Details
0	Control word	See <i>chapter 7.2.2.2 Control Word (Write-only)</i> for details.
1		
2	Reserved	Must be 0.
3		

Table 7.2 Valid Assembly Instance

1) All fields are in littleendian format.

7.2.2.2 Control Word (Write-only)

Use the structure in *Table 7.3* to send a control command to the soft starter.

Byte	Bit	Function	
0	0–5	Reserved	Must be 0.
	6	Run	0 = Stop command 1 = Start command
	7	Reset	Changing this bit from 0 to 1 resets a trip.
1	0–4	Reserved	Must be 0.
	5	Motor set select	0 = Use primary motor set when starting ¹⁾ 1 = Use secondary motor set when starting ¹⁾
	6–7	Reserved	Must be 0.

Table 7.3 Control Word Structure

1) Ensure that the programmable input is not set to motor set select before using this function.

7.2.2.3 Command Examples

Byte	Value	Description
Command: Start a soft starter		
0	<ul style="list-style-type: none"> • 0b11000000 (0XC0) or • 0b01000000 (0X40) 	0bX1000000, where X represents 0 or 1 in the reset field.
Command: Select primary or secondary motor settings		
1	<ul style="list-style-type: none"> • 0b00000000 (0X0) or • 0b00100000 (0X20) 	Select primary motor settings. Select secondary motor settings.
Command: Reset a soft starter		
0	<ul style="list-style-type: none"> • 0b11000000 (0XC0) or • 0b10000000 (0X80) 	The reset only occurs when the previous reset bit is 0, otherwise the value of 1 is ignored.
Command: Stop a soft starter		
0	0bX0000000	

Table 7.4 Control Commands

7.2.3 Status Information

7.2.3.1 Reading Status Information from the Soft Starter

The EtherNet/IP Module uses input assembly instance 154d in assembly class 0X04 to send status information to the controller. This is the only valid assembly instance.

Byte	Function	Details
0	Status word	See <i>chapter 7.2.3.2 Status Word (Read-only)</i> for details.
1		
2	Reserved	Must be 0.
3		
4	Motor current	Measured current is represented as a 32-bit value to 2 decimal places: 0000001 hex = 0.01 A 0000064 hex = 1.00 A 0010D47 hex = 689.35 A
5		
6		
7		
8	Trip code	See <i>chapter 7.2.3.3 Trip Codes</i> .
9		
10	Reserved	Must be 0.
11		

Table 7.5 Status Information

7.2.3.2 Status Word (Read-only)

Use the structure in *Table 7.6* to query the status of the soft starter.

Bit	Function	Details	MCD 201	MCD 202	MCD 500
0	Ready	0 = Start or stop command not acceptable 1 = Start or stop command acceptable	✓	✓	✓
1	Control from net	0 = Program mode 1 = Control from net			✓
2	Coasting	0 = Coasting 1 = Enabled	✓	✓	✓
3	Trip	0 = Not tripped 1 = Tripped	✓	✓	✓
4	Reserved	Must be 0			
5	Reserved	Must be 0			
6	Reserved	Must be 0			
7	Warning	0 = No warning 1 = Warning			✓
8	Ramping	0 = Not at full voltage (non-bypassed) 1 = Running (full voltage at the motor)	✓	✓	✓
9	Local/remote	0 = Local control 1 = Remote control			✓
10	Reserved	Must be 0			
11	On	0 = Unknown, not ready, ready to start, or tripped 1 = Starting, running, stopping, or jogging	✓	✓	✓
12	Reserved	Must be 0			
13	Reserved	Must be 0			
14	Reserved	Must be 0			
15	Temperature limit	0 = Motor operating below normal operating temperature 1 = Motor operating above normal operating temperature	✓	✓	✓

Table 7.6 Status Commands

7.2.3.3 Trip Codes

The trip code is reported in bytes 2–3 and 17 of the status word.

Trip code	Description	MCD 201	MCD 202	MCD 500
0	No trip	✓	✓	✓
11	Input A trip			✓
20	Motor overload		✓	✓
21	Heat sink overtemperature			✓
23	L1 phase loss			✓
24	L2 phase loss			✓
25	L3 phase loss			✓
26	Current imbalance		✓	✓
28	Instantaneous overcurrent			✓
29	Undercurrent			✓
50	Power loss	✓	✓	✓
54	Phase sequence		✓	✓
55	Frequency	✓	✓	✓
60	Unsupported option (function not available in inside delta)			✓
61	FLC too high			✓
62	Parameter out of range			✓

Trip code	Description	MCD 201	MCD 202	MCD 500
70	Miscellaneous, including: Current read err Lx ATTENTION! Remove mains volts Motor connection Tx Firing fail Px VZC fail Px Low control volts			✓
75	Motor thermistor		✓	✓
101	Excess start time		✓	✓
102	Motor connection			✓
103	Shorted SCR			✓
113	Starter communication (between module and soft starter)	✓	✓	✓
114	Network communication (between module and network)	✓	✓	✓
115	L1-T1 shorted			✓
116	L2-T2 shorted			✓
117	L3-T3 shorted			✓
118	Motor 2 overload			✓
119 ¹⁾	Time-overcurrent (bypass overload)		✓	✓
121	Battery/clock			✓
122	Thermistor circuit			✓

Table 7.7 Trip Codes

1) For VLT® Soft Starter MCD 500, time-overcurrent protection is only available on internally bypassed models.

7.3 Acyclic Operation

This section provides information on objects, instances, and attributes for acyclic operation. It also lists the requirements related to acyclic services for the EtherNet/IP Module.

7.3.1 Class 0X01 Identity Object

The EtherNet/IP Module supports the attributes for identity objects listed in Table 7.8.

Attribute	Function	Description
1	Vendor	Supported
2	Device type	The attribute value is 12d
3	Product code	Supported
4	Revision: Major, minor	Revision value set in the EDS file
5	Status	Status of the netIC module
6	Serial number	Serial number of the netIC module
7	Product name	Supported

Table 7.8 Identity Object Attributes

7.3.2 Vendor-specific Objects

The EtherNet/IP Module supports vendor-specific class objects 100, 101, 103, and 104.

7.3.2.1 Class 100 Objects (Read/Write)

Object name	Class	Instance	Attribute
Motor full load current	100	101	100
Locked rotor time	100	102	100
Start mode	100	103	100
Current limit	100	104	100
Initial current	100	105	100
Start ramp time	100	106	100
Kickstart level	100	107	100
Kickstart time	100	108	100
Excess start time	100	109	100
Stop mode	100	110	100
Stop time	100	111	100
Adaptive control gain	100	112	100
Adaptive start profile	100	113	100
Adaptive stop profile	100	114	100
Brake torque	100	115	100
Brake time	100	116	100
Phase sequence	100	117	100
Current imbalance	100	118	100
Current imbalance delay	100	119	100
Undercurrent	100	120	100
Undercurrent delay	100	121	100
Instantaneous overcurrent	100	122	100
Instantaneous overcurrent delay	100	123	100
Frequency check	100	124	100
Frequency variation	100	125	100
Frequency delay	100	126	100

Object name	Class	Instance	Attribute
Restart delay	100	127	100
Motor temperature check	100	128	100
Local/remote	100	129	100
Comms in remote	100	130	100
Input A function	100	131	100
Input A name	100	132	100
Input A trip	100	133	100
Input A trip delay	100	134	100
Input A initial delay	100	135	100
Remote reset logic	100	136	100
Relay A function	100	137	100
Relay A on delay	100	138	100
Relay A off delay	100	139	100
Relay B function	100	140	100
Relay B on delay	100	141	100
Relay B off delay	100	142	100
Relay C function	100	143	100
Relay C on delay	100	144	100
Relay C off delay	100	145	100
Low current flag	100	146	100
High current flag	100	147	100
Motor temperature flag	100	148	100
Analog output A	100	149	100
Analog A scale	100	150	100
Analog A maximum adjustment	100	151	100
Analog A minimum adjustment	100	152	100
Auto-start type	100	153	100
Auto-start time	100	154	100
Auto-stop type	100	155	100
Auto-stop time	100	156	100
Auto-reset action	100	157	100
Maximum resets	100	158	100
Reset delay groups A&B	100	159	100
Reset delay group C	100	160	100
Motor FLC-2	100	161	100
Locked rotor time-2	100	162	100
Start mode-2	100	163	100
Current limit-2	100	164	100
Initial current-2	100	165	100
Start ramp-2	100	166	100
Kickstart level-2	100	167	100
Kickstart time-2	100	168	100
Excess start time-2	100	169	100
Stop mode-2	100	170	100
Stop time-2	100	171	100
Adaptive control gain-2	100	172	100
Adaptive start profile-2	100	173	100
Adaptive stop profile-2	100	174	100
Brake torque-2	100	175	100
Brake time-2	100	176	100
Language	100	177	100
User screen - top left	100	178	100
User screen - top right	100	179	100

Object name	Class	Instance	Attribute
User screen - bottom left	100	180	100
User screen - bottom right	100	181	100
Graph timebase	100	182	100
Graph maximum adjustment	100	183	100
Graph minimum adjustment	100	184	100
Mains reference voltage	100	185	100
Access code	100	186	100
Adjustment lock	100	187	100
Emergency run	100	188	100
Current calibration	100	189	100
Main contactor time	100	190	100
Bypass contactor time	100	191	100
Motor connection	100	192	100
Jog torque	100	193	100
Motor overload	100	194	100
Current imbalance	100	195	100
Undercurrent	100	196	100
Instaneaneous overcurrent	100	197	100
Frequency	100	198	100
Heat sink overtemperature	100	199	100

Table 7.9 Class 100 Objects

7.3.2.2 Class 101 Objects (Read/Write)

Object name	Class	Instance	Attribute
Excess start time	101	100	100
Input A trip	101	101	100
Motor thermistor	101	102	100
Starter communication	101	103	100
Network communication	101	104	100
Battery/clock	101	105	100
Low control volts	101	106	100
Comms timeout	101	107	100
Tracking gain	101	108	100
Tracking gain-2	101	109	100
Frequency detect	101	110	100
Bypass protection	101	111	100
Pedestal detect	101	112	100

Table 7.10 Class 101 Objects

7.3.2.3 Class 103 Objects (Read-only)

Object name	Class	Instance	Attribute
Binary protocol version	103	100	100
Product type code	103	101	100
Minor software version	103	102	100
Major software version	103	103	100
Soft starter model	103	104	100
Parameter changed	103	105	100
Num parameter	103	106	100
Parameter value	103	107	100

Object name	Class	Instance	Attribute
Access type	103	108	100
Starter state	103	109	100
Warning	103	110	100
Initialized	103	111	100
Reserved	103	112	100
Parameters have changed	103	113	100
Phase sequence	103	114	100
Trip/warning code	103	115	100
Current	103	116	100
Current % of FLC	103	117	100
Motor 1 temperature	103	118	100
Motor 2 temperature	103	119	100
Power (W)	103	120	100
Power scale	103	121	100
% power factor	103	122	100
Voltage (refers to mains reference voltage)	103	123	100
Phase 1 current	103	124	100
Phase 2 current	103	125	100
Phase 3 current	103	126	100
Phase 1 voltage (refers to mains reference voltage)	103	127	100
Phase 2 voltage (refers to mains reference voltage)	103	128	100
Phase 3 voltage (refers to mains reference voltage)	103	129	100
Minor revision	103	130	100
Major revision	103	131	100

Table 7.11 Class 103 Objects

7.3.2.4 Class 104 Objects (Read-only)

Object name	Class	Instance	Attribute
Major software version	104	101	100
Minor software version	104	102	100
Major software version	104	103	100
Minor software version	104	104	100
Major software version	104	105	100
Minor software version	104	106	100
Major software version	104	107	100
Minor software version	104	108	100
Model	104	109	100
Control variant	104	110	100
Backplane variant	104	111	100
Actual motor current	104	112	100
Variant high byte	104	113	100
Customer	104	114	100

Table 7.12 Class 104 Objects

7.3.3 Supported Services for Vendor-specific Objects

This section describes the operational instructions to carry out acyclic services on class objects 100, 101, 103, and 104.

The EtherNet/IP Module supports the services for vendor-specific objects in *Table 7.13*.

Service code	Function	Description
0x01	Get attribute all	Only supported for class 0x01 identity object
0x10	Set attribute single	Supported
0x0E	Get attribute single	Supported

Table 7.13 Supported Services

7.3.3.1 Set Attribute Single

To set an attribute, use the service code 0x10 (set attribute single). For details on returned status codes, see *chapter 7.3.3.3 Status Codes for Acyclic Services*.

Illustration 7.1 shows the successful writing of *parameter 1-01 Motor Full Load Current* (Class 100, Instance 101).

NOTICE

Class and service code are written in hexadecimal values, while instance is in decimal values.

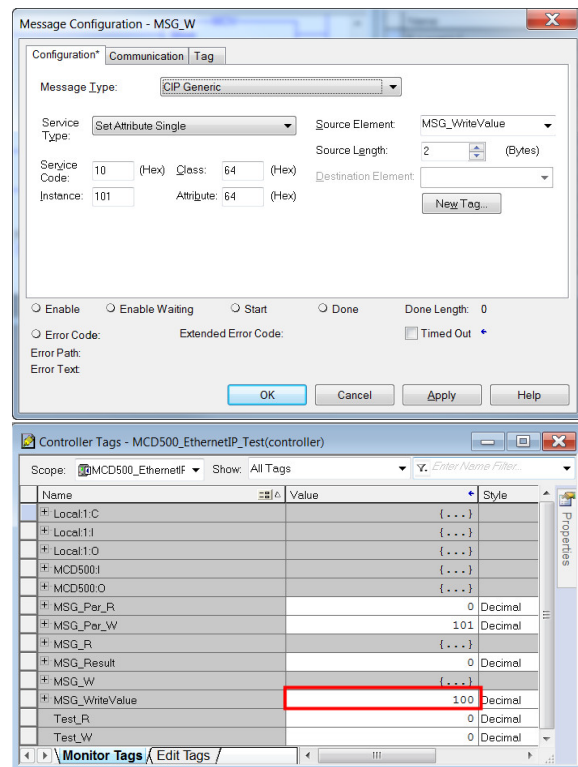

177HA681.11

Illustration 7.1 Example: Setting the Value of Class 0x64 Instance 101 - Successful

Writing to a parameter that does not exist (or is read-only) results in an error.

Illustration 7.2 shows the example of an attempt to write to a non-existing parameter (Class 101, Instance 113).

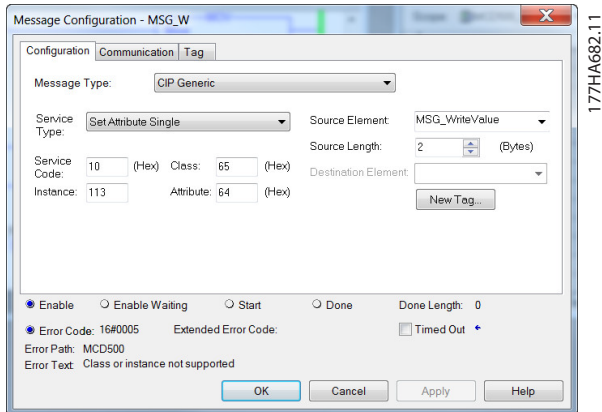

Illustration 7.2 Example: Setting the Value of Class 0x65 Instance 113 - Error

7.3.3.2 Get Attribute Single

To get an attribute, use the service code 0x0E (get attribute single). For details on returned status codes, see chapter 7.3.3.3 Status Codes for Acyclic Services.

Illustration 7.3 shows the successful reading of parameter 1-09 Excess Start Time (Class 100, Instance 109).

NOTICE

Class and service code are written in hexadecimal values, while instance is in decimal values.

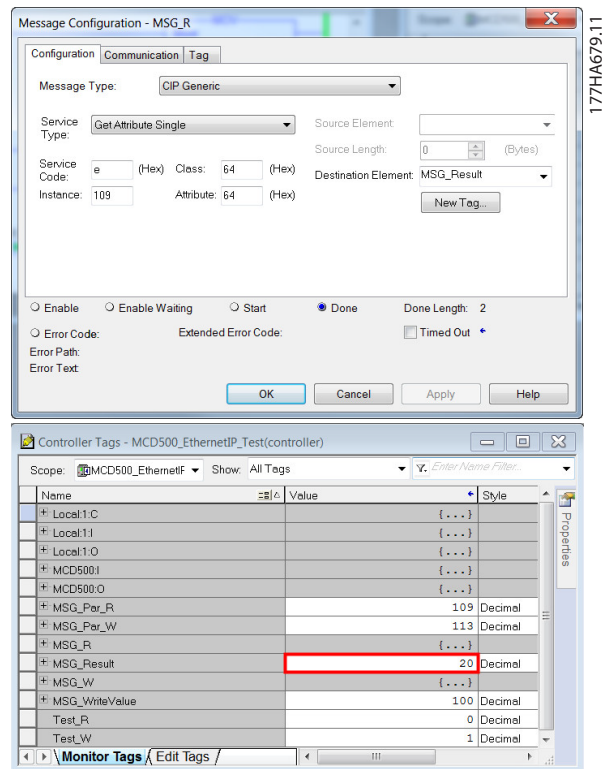

Illustration 7.3 Example: Retrieving the Value of Class 0x64, Instance 109 - Successful

Reading a parameter that does not exist results in an error. Illustration 7.4 shows the example of an attempt to read a non-existing parameter (Class 101, Instance 113).

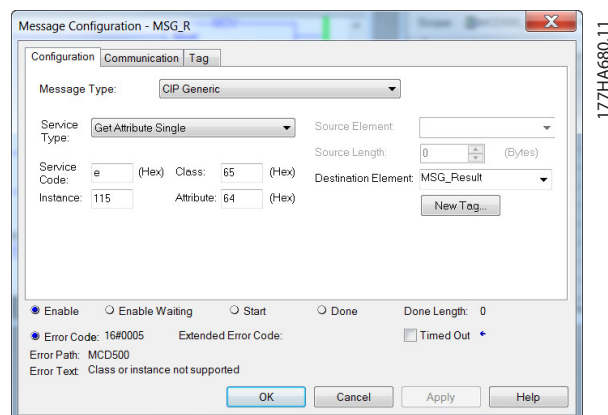

Illustration 7.4 Example: Retrieving the Value of Class 0x65, Instance 113 - Error

7.3.3.3 Status Codes for Acyclic Services

Status code	Status name	Comments
0x00	Success	This code is returned after successful execution of the service, that is <ul style="list-style-type: none"> • When the register mapped for service Get attribute single is successfully read. • When the register mapped for service Set attribute single is successfully set.
0x03	Invalid parameter value	–
0x05	Path destination unknown	The mapped register does not exist.
0x08	Service not supported	The requested service is not available for this Object class/instance.
0x09	Invalid attribute value	This code only applies to the service Set attribute single. It is returned if the value is out of range for the mapped register.
0x0E	Attribute not settable	This code only applies to the service Set attribute single. It is returned if the mapped register is read-only.
0x14	Attribute not supported	The attribute specified in the request is not supported.
0x16	Object does not exist	The object specified does not exist in the device.

Table 7.14 Status Codes, Get/Set Attribute Single

8 Network Design

The EtherNet/IP Module supports star, line, and ring topologies.

8.1 Star Topology

In a star network, all controllers and devices connect to a central network switch.

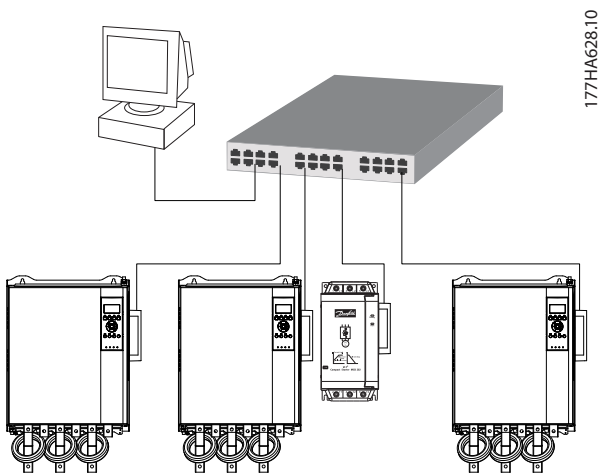

177HA628.10

Illustration 8.1 Star Network Topology

8.2 Line Topology

In a line network, the controller connects directly to 1 port of the first EtherNet/IP Module. The 2nd Ethernet port of the EtherNet/IP Module connects to another module, which in turn connects to another module until all devices are connected.

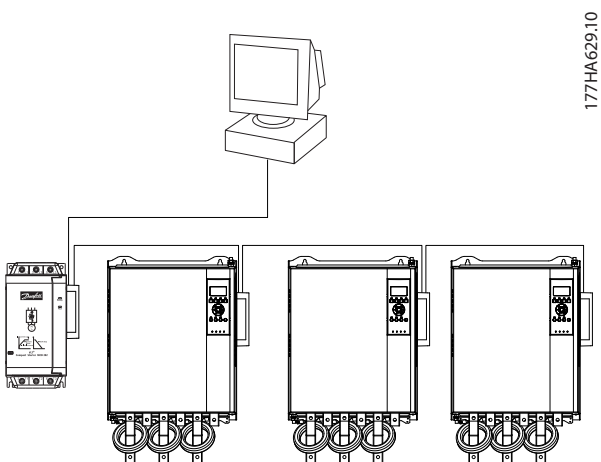

177HA629.10

Illustration 8.2 Line Network Topology

NOTICE

The EtherNet/IP Module has an integrated switch to allow data to pass through in line topology. The EtherNet/IP Module must be receiving control power from the soft starter for the switch to operate.

NOTICE

If the connection between 2 devices is interrupted, the controller cannot communicate with devices after the interruption point.

NOTICE

Each connection adds a delay to communication with the next module. The maximum number of devices in a line network is 32. Exceeding this number may reduce the reliability of the network.

8.3 Ring Topology

In a ring topology network, the controller connects to the 1st EtherNet/IP Module via a network switch. The 2nd Ethernet port of the EtherNet/IP Module connects to another module, which in turn connects to another module until all devices are connected. The final module connects back to the switch.

The EtherNet/IP Module supports beacon-based ring node configuration.

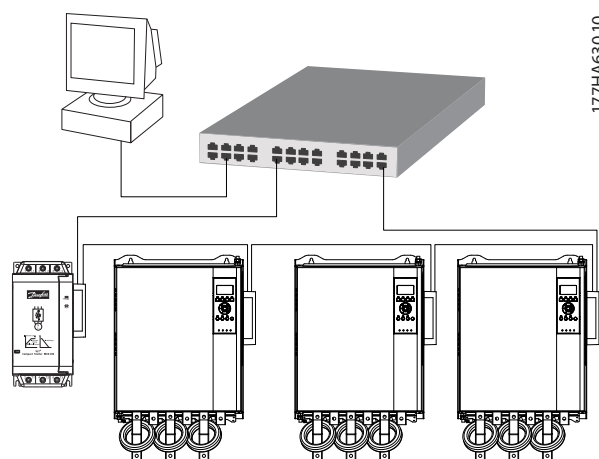

177HA630.10

Illustration 8.3 Ring Network Topology

NOTICE

The network switch must support loss of line detection.

8.4 Combined Topologies

A single network can include both star and line components.

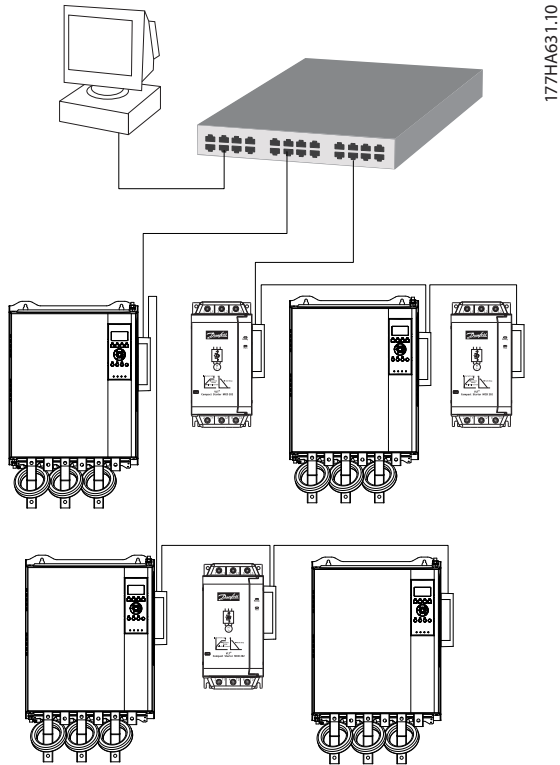

177HA63.1.10

8

Illustration 8.4 Combined Star/Line Network Topology

9 Specifications

Enclosure	
Dimensions, W x H x D [mm (in)]	40 x 166 x 90 (1.6 x 6.5 x 3.5)
Weight	250 g (8.8 Oz)
Protection	IP20
Mounting	
Spring-action plastic mounting clips	2
Connections	
Soft starter	6-way pin assembly
Contacts	Gold flash
Networks	RJ45
Settings	
IP address	BootP, automatically assigned, configurable
Device name	Configurable
Network	
Link speed	10 Mbps, 100 Mbps (auto-detect)
Full duplex	
Auto crossover	
Power	
Consumption (steady state, maximum)	35 mA at 24 V DC
Reverse polarity protected	
Galvanically isolated	
Certification	
RCM	IEC 60947-4-2
CE	IEC 60947-4-2
ODVA	EtherNet/IP conformance tested
Environmental	
Operating temperature	-10 to +60 °C (14–140 °F), above 40 °C (104 °F) with derating
Storage temperature	-25 to +60 °C (-13 to +140 °F)
Humidity	5–95% relative humidity
Pollution degree	Pollution degree 3
Vibration	IEC 60068-2-6

Index

A

Abbreviations.....	4
Acyclic service.....	16
Additional resources.....	3
Approvals.....	3
Assembly class.....	13, 14
Assembly instance.....	14
Assembly object.....	13
Auto-on mode.....	5

B

Bus bar.....	5
--------------	---

C

Cable	
category.....	8
Ethernet cable.....	9
Capacitors	
Power factor correction capacitor.....	5
Certifications.....	3
Class object.....	16
Commands	
Control.....	13, 14
Start.....	13, 15
Status.....	15
Stop.....	13, 15
Connections.....	23
Contactors	
Bypass contactor.....	5
Main contactor.....	5
Control command.....	13, 14
Control word.....	13
Control word structure.....	13
Conventions.....	4
Cyclic service.....	13

D

Dimensions.....	23
-----------------	----

E

Electromagnetic interference.....	9
Ethernet attribute.....	10

H

Heat sink.....	5
----------------	---

I

Identity object.....	16
Inputs	
Remote.....	5
Installing EtherNet/IP option.....	7
Intended use.....	3
IP address.....	9, 10, 12, 23
IP address conflict.....	10

L

LED	
Description.....	12
LED.....	4
Name.....	12
Status.....	12

M

MAC address.....	9
Motor	
connection.....	5

N

Network	
Auto crossover.....	23
Full duplex.....	23
Line.....	21
Link speed.....	23
Ring.....	21
Star.....	21

Q

Qualified personnel.....	3
--------------------------	---

R

Removing EtherNet/IP Option.....	7
Reset mode.....	8

S

Start command.....	13, 15
Status command.....	15
Status word.....	14
Stop command.....	13, 15
Subnet mask.....	10
Supply.....	5
Symbols.....	4

T

Terminals	
N1.....	8
N2.....	8

W

Weight..... 23



.....
Danfoss can accept no responsibility for possible errors in catalogues, brochures and other printed material. Danfoss reserves the right to alter its products without notice. This also applies to products already on order provided that such alterations can be made without subsequential changes being necessary in specifications already agreed. All trademarks in this material are property of the respective companies. Danfoss and the Danfoss logotype are trademarks of Danfoss A/S. All rights reserved.
.....

Danfoss A/S
Ulsnaes 1
DK-6300 Graasten
vlt-drives.danfoss.com

