



Design Guide

VLT[®] HVAC Basic Drive FC 101



Contents

1 Introduction	5
1.1 Purpose of the Manual	5
1.2 Document and Software Version	5
1.3 Safety Symbols	5
1.4 Abbreviations	5
1.5 Additional Resources	6
1.6 Definitions	6
1.7 Power Factor	8
2 Product Overview	9
2.1 Safety	9
2.2 CE Labeling	10
2.3 Air Humidity	11
2.4 Aggressive Environments	12
2.5 Vibration and Shock	12
2.6 Advantages	12
2.7 Control Structures	26
2.7.1 Control Principle	26
2.7.2 Control Structure Open-loop	26
2.7.3 PM/EC+ Motor Control	26
2.7.4 Local (Hand On) and Remote (Auto On) Control	27
2.7.5 Control Structure Closed-loop	28
2.7.6 Feedback Conversion	28
2.7.7 Reference Handling	29
2.7.8 Closed-loop Set-up Wizard	31
2.7.9 Tuning the Drive Closed-loop Controller	34
2.7.10 Manual PI Adjustment	34
2.8 General Aspects of EMC	35
2.8.1 Emission Requirements	36
2.9 Galvanic Isolation (PELV)	41
2.10 Ground Leakage Current	42
2.11 Extreme Running Conditions	42
3 Selection	45
3.1 Options and Accessories	45
3.1.1 Local Control Panel (LCP)	45
3.1.2 Mounting of LCP in Panel Front	45
3.1.3 IP21/TYP E 1 Enclosure Kit	46

3.1.4 Decoupling Plate	48
4 How to Order	49
4.1 Configuration	49
4.2 Ordering Numbers	51
5 How to Install	54
5.1 Mechanical Dimensions	54
5.1.1 Adjustable Frequency Drive Dimensions	54
5.1.2 Shipping Dimensions	57
5.2 Electrical Data	58
5.2.1 Electrical Installation in General	59
5.2.2 Connecting to Line Power and Motor	60
5.2.3 Fuses and Circuit Breakers	67
5.2.5 Control Terminals	72
6 How to Program	73
6.1 Programming with MCT 10 Set-up Software	73
6.2 Local Control Panel (LCP)	73
6.3 Menus	74
6.3.1 Status Menu	74
6.3.2 Quick Menu	74
6.3.3 Start-up Wizard for Open-loop Applications	74
6.3.4 Main Menu	84
6.4 Quick Transfer of Parameter Settings between Multiple Adjustable Frequency Drives	84
6.5 Readout and Programming of Indexed Parameters	84
6.6 Initialize the Adjustable Frequency Drive to Default Settings in Two Ways	85
7 RS-485 Installation and Set-up	86
7.1 RS-485	86
7.1.1 Overview	86
7.1.2 Network Connection	86
7.1.3 Adjustable Frequency Drive Hardware Set-up	87
7.1.4 Adjustable Frequency Drive Parameter Settings for Modbus Communication	87
7.1.5 EMC Precautions	88
7.2 Adjustable Frequency Protocol Overview	88
7.3 Network Configuration	88
7.4 FC Protocol Message Framing Structure	89

7.4.1 Content of a Character (byte)	89
7.4.2 Message Structure	89
7.4.3 Message Length (LGE)	89
7.4.4 Adjustable Frequency Drive Address (ADR)	89
7.4.5 Data Control Byte (BCC)	89
7.4.6 The Data Field	90
7.4.7 The PKE Field	91
7.4.8 Parameter Number (PNU)	91
7.4.9 Index (IND)	91
7.4.10 Parameter Value (PWE)	92
7.4.11 Data Types Supported by the Adjustable Frequency Drive	92
7.4.12 Conversion	92
7.4.13 Process Words (PCD)	92
7.5 Examples	92
7.6 Modbus RTU Overview	93
7.6.1 Assumptions	93
7.6.2 What the User Should Already Know	93
7.6.3 Modbus RTU Overview	93
7.6.4 Adjustable Frequency Drive with Modbus RTU	94
7.7 Network Configuration	94
7.8 Modbus RTU Message Framing Structure	94
7.8.1 Adjustable Frequency Drive with Modbus RTU	94
7.8.2 Modbus RTU Message Structure	95
7.8.3 Start/Stop Field	95
7.8.4 Address Field	95
7.8.5 Function Field	95
7.8.6 Data Field	95
7.8.7 CRC Check Field	96
7.8.8 Coil Register Addressing	96
7.8.9 How to Control the Adjustable Frequency Drive	98
7.8.10 Function Codes Supported by Modbus RTU	98
7.8.11 Modbus Exception Codes	98
7.9 How to Access Parameters	99
7.9.1 Parameter Handling	99
7.9.2 Storage of Data	99
7.9.3 IND	99
7.9.4 Text Blocks	99
7.9.5 Conversion Factor	99

7.9.6 Parameter Values	99
7.10 Examples	99
7.10.1 Read Coil Status (01 HEX)	99
7.10.2 Force/Write Single Coil (05 HEX)	100
7.10.3 Force/Write Multiple Coils (0F HEX)	101
7.10.4 Read Holding Registers (03 HEX)	101
7.10.5 Preset Single Register (06 HEX)	102
7.10.6 Preset Multiple Registers (10 HEX)	102
7.11 Danfoss FC Control Profile	103
7.11.1 Control Word According to FC Profile (8-10 Protocol = FC profile)	103
7.11.2 Status Word According to FC Profile (STW) (8-30 Protocol = FC profile)	104
7.11.3 Bus Speed Reference Value	105
8 General Specifications and Troubleshooting	106
8.1 Line Power Supply Specifications	106
8.1.1 Line Power Supply 3x200–240 V AC	106
8.1.2 Line Power Supply 3x380–480 V AC	107
8.1.3 Line Power Supply 3x380–480 V AC	111
8.1.4 Line Power Supply 3x525–600 V AC	113
8.2 General Specifications	114
8.3 Acoustic Noise or Vibration	117
8.4 dU/Dt	118
8.5 Derating according to Ambient Temperature and Switching Frequency	120
Index	126

1 Introduction

1.1 Purpose of the Manual

This design guide provides information on how to select, commission and order an adjustable frequency drive. It provides information about the mechanical and electrical installation.

The design guide is intended for use by qualified personnel.

Read and follow the design guide to use the adjustable frequency drive safely and professionally, and pay particular attention to the safety instructions and general warnings.

1.2 Document and Software Version

This manual is regularly reviewed and updated. All suggestions for improvement are welcome. *Table 1.1* shows the document version and the corresponding software version.

Edition	Remarks	Software version
MG18C5xx	Replaces MG18C4xx	2.51

Table 1.1 Document and Software Version

1.3 Safety Symbols

The following symbols are used in this document.

⚠ WARNING

Indicates a potentially hazardous situation which could result in death or serious injury.

⚠ CAUTION

Indicates a potentially hazardous situation which could result in minor or moderate injury. It may also be used to alert against unsafe practices.

NOTICE!

Indicates important information, including situations that may result in damage to equipment or property.

1.4 Abbreviations

Alternating current	AC
American wire gauge	AWG
Ampere/AMP	A
Automatic Motor Adaptation	AMA
Current limit	I_{LIM}
Degrees Celsius	°C
Direct current	DC
Electro Magnetic Compatibility	EMC
Electronic Thermal Relay	ETR
Adjustable Frequency Drive	FC
Gram	g
Hertz	Hz
Kilohertz	kHz
Local Control Panel	LCP
Meter	m
Millihenry Inductance	mH
Milliamper	mA
Millisecond	ms
Minute	min
Motion Control Tool	MCT
Nanofarad	nF
Newton Meters	Nm
Nominal motor current	$I_{M,N}$
Nominal motor frequency	$f_{M,N}$
Nominal motor power	$P_{M,N}$
Nominal motor voltage	$U_{M,N}$
Protective Extra Low Voltage	PELV
Printed Circuit Board	PCB
Rated Inverter Output Current	I_{INV}
Revolutions Per Minute	RPM
Regenerative terminals	Regen
Second	s
Synchronous Motor Speed	n_s
Torque limit	T_{LIM}
Volts	V
The maximum output current	$I_{DRIVE,MAX}$
The rated output current supplied by the adjustable frequency drive	$I_{DRIVE,N}$

Table 1.2 Abbreviations

1.5 Additional Resources

1.6 Definitions

Adjustable Frequency Drive

$I_{DRIVE,MAX}$

The maximum output current.

$I_{DRIVE,N}$

The rated output current supplied by the adjustable frequency drive.

$U_{DRIVE,MAX}$

The maximum output voltage.

Input

The connected motor can start and stop with LCP and the digital inputs. Functions are divided into two groups. Functions in group 1 have higher priority than functions in group 2.	Group 1	Reset, Coasting stop, Reset and Coasting stop, Quick Stop, DC braking, Stop and the [Off] key.
	Group 2	Start, Pulse start, Reversing, Start reversing, Jog and Freeze output

Table 1.3 Control Commands

Motor

f_{JOG}

The motor frequency when the jog function is activated (via digital terminals).

f_M

The motor frequency.

f_{MAX}

The maximum motor frequency.

f_{MIN}

The minimum motor frequency.

$f_{M,N}$

The rated motor frequency (nameplate data).

I_M

The motor current.

$I_{M,N}$

The rated motor current (nameplate data).

$n_{M,N}$

The rated motor speed (nameplate data).

$P_{M,N}$

The rated motor power (nameplate data).

U_M

The instantaneous motor voltage.

$U_{M,N}$

The rated motor voltage (nameplate data).

Break-away torque

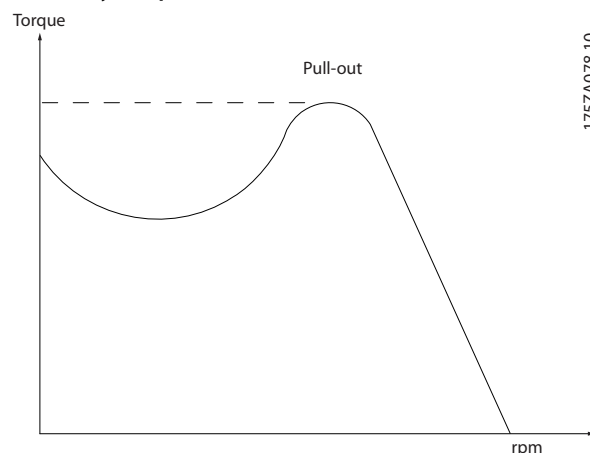

Figure 1.1 Break-away torque

η_{DRIVE}

The efficiency of the adjustable frequency drive is defined as the ratio between the power output and the power input.

Start-disable command

A stop command belonging to the group 1 control commands, see Table 1.3.

Stop command

See Control commands.

References

Analog reference

A signal transmitted to the analog inputs 53 or 54, can be voltage or current.

Bus reference

A signal transmitted to the serial communication port (drive port).

Preset reference

A defined preset reference to be set from -100% to +100% of the reference range. Selection of eight preset references via the digital terminals.

RefMAX

Determines the relationship between the reference input at 100% full scale value (typically 10 V, 20 mA) and the resulting reference. The maximum reference value set in 3-03 Maximum Reference

RefMIN

Determines the relationship between the reference input at 0% value (typically 0 V, 0 mA, 4 mA) and the resulting reference. The minimum reference value set in 3-02 Minimum Reference

Miscellaneous**Analog inputs**

The analog inputs are used for controlling various functions of the adjustable frequency drive.

There are two types of analog inputs:

Current input, 0–20 mA and 4–20 mA

Voltage input, 0–10 V DC.

Analog outputs

The analog outputs can supply a signal of 0–20 mA, 4–20 mA, or a digital signal.

Automatic Motor Adaptation, AMA

AMA algorithm determines the electrical parameters for the connected motor at standstill.

Digital inputs

The digital inputs can be used for controlling various functions of the adjustable frequency drive.

Digital outputs

The adjustable frequency drive features two solid state outputs that can supply a 24 V DC (max. 40 mA) signal.

Relay outputs

The adjustable frequency drive features two programmable relay outputs.

ETR

Electronic Thermal Relay is a thermal load calculation based on present load and time. Its purpose is to estimate the motor temperature.

Initializing

If initialization is carried out (*14-22 Operation Mode*), the programmable parameters of the adjustable frequency drive return to their default settings.

Initializing; *14-22 Operation Mode* does not initialize communication parameters.

Intermittent duty cycle

An intermittent duty rating refers to a sequence of duty cycles. Each cycle consists of an on-load and an off-load period. The operation can be either periodic duty or non-periodic duty.

Keypad

The keypad makes up a complete interface for control and programming of the adjustable frequency drive. The keypad is detachable and can be installed up to 10 ft [3 m] from the adjustable frequency drive i.e., in a front panel using the installation kit option.

lsb

Least significant bit.

MCM

Short for Mille Circular Mil, an American measuring unit for cable cross-section. 1 MCM \equiv 0.5067 mm².

msb

Most significant bit.

Online/offline parameters

Changes to online parameters are activated immediately after the data value is changed. Press [OK] to activate off-line parameters.

PI controller

The PI controller maintains the desired speed, pressure, temperature, etc. by adjusting the output frequency to match the varying load.

RCD

Residual Current Device.

Set-up

Parameter settings in two set-ups can be saved. Change between the four parameter set-ups and edit one set-up, while another set-up is active.

Slip compensation

The adjustable frequency drive compensates for the motor slip by giving the frequency a supplement that follows the measured motor load, keeping the motor speed almost constant.

Smart Logic Control (SLC)

The SLC is a sequence of user-defined actions executed when the associated user-defined events are evaluated as true by the SLC.

Thermistor

A temperature-dependent resistor placed where the temperature is to be monitored (adjustable frequency drive or motor).

Trip

A state entered in fault situations, e.g., if the adjustable frequency drive is subject to an overtemperature or when the adjustable frequency drive is protecting the motor, process or mechanism. Restart is prevented until the cause of the fault has disappeared and the trip state is canceled by activating reset or, in some cases, by being programmed to reset automatically. Trip may not be used for personal safety.

Trip locked

A state entered in fault situations when the adjustable frequency drive is protecting itself and requiring physical intervention, for example, if the adjustable frequency drive is subject to a short circuit on the output. A locked trip can only be canceled by cutting off line power, removing the cause of the fault, and reconnecting the adjustable frequency drive. Restart is prevented until the trip state is canceled by activating reset or, in some cases, by being programmed to reset automatically. The trip-lock function may not be used as a personal safety measure.

VT Characteristics

Variable torque characteristics used for pumps and fans.

VVC^{plus}

Compared with standard voltage/frequency ratio control, Voltage Vector Control (VVC^{plus}) improves the dynamics and stability, both when the speed reference is changed and in relation to the load torque.

1.7 Power Factor

The power factor is the relation between I_1 and I_{RMS} .

$$\text{Power factor} = \frac{\sqrt{3} \times U \times I_1 \times \text{COS}\phi}{\sqrt{3} \times U \times I_{RMS}}$$

The power factor for 3-phase control:

$$= \frac{I_1 \times \text{COS}\phi}{I_{RMS}} = \frac{I_1}{I_{RMS}} \text{ since } \text{COS}\phi = 1$$

The power factor indicates to which extent the adjustable frequency drive imposes a load on the line power supply. The lower the power factor, the higher the I_{RMS} for the same kW performance.

$$I_{RMS} = \sqrt{I_1^2 + I_5^2 + I_7^2 + \dots + I_n^2}$$

In addition, a high power factor indicates that the different harmonic currents are low.

The adjustable frequency drive's built-in DC coils produce a high power factor, which minimizes the imposed load on the line power supply.

2 Product Overview

2.1 Safety

2.1.1 Safety Note

⚠ WARNING

DANGEROUS VOLTAGE

The voltage of the adjustable frequency drive is dangerous whenever connected to line power. Incorrect installation of the motor, adjustable frequency drive or serial communication bus may cause death, serious personal injury or damage to the equipment. Consequently, the instructions in this manual, as well as national and local rules and safety regulations, must be complied with.

Safety Regulations

1. Disconnect the adjustable frequency drive from line power if repair work is to be carried out. Make sure that the line power supply has been disconnected and that the necessary time has passed before removing motor and line power plugs.
2. The [Off/Reset] key does not disconnect the equipment from line power and is thus not to be used as a safety switch.
3. Correct protective grounding of the equipment must be established, the user must be protected against supply voltage, and the motor must be protected against overload in accordance with applicable national and local regulations.
4. The ground leakage currents are higher than 3.5 mA.
5. Protection against motor overload is set by *1-90 Motor Thermal Protection*. If this function is desired, set *1-90 Motor Thermal Protection* to data value [4], [6], [8], [10] *ETR trip* or data value [3], [5], [7], [9] *ETR warning*.
Note: The function is initialized at 1.16 x rated motor current and rated motor frequency. For the North American market: The ETR functions provide class 20 motor overload protection in accordance with NEC.

Safety Regulations

6. Do not remove the plugs for the motor and line power supply while the adjustable frequency drive is connected to line power. Make sure that the line power supply has been disconnected and that the necessary time has elapsed before removing motor and line power plugs.
7. Check that all voltage inputs have been disconnected and that the necessary time has elapsed before commencing repair work.

Installation at high altitudes

⚠ CAUTION

At altitudes above 6,600 ft [2 km], contact Danfoss regarding PELV.

⚠ WARNING

UNINTENDED START

1. The motor can be brought to a stop with digital commands, bus commands, references or a local stop, while the adjustable frequency drive is connected to line power. These stop functions are not sufficient to avoid unintended start and thus prevent personal injury.
2. While parameters are being changed, the motor may start. Consequently, always activate the stop key [Off/Reset] before modifying data.
3. A motor that has been stopped may start if faults occur in the electronics of the adjustable frequency drive, or if a temporary overload or a fault in the line power or the motor connection ceases.

⚠ WARNING

HIGH VOLTAGE

Adjustable frequency drives contain high voltage when connected to AC line power. Installation, start-up, and maintenance should be performed by qualified personnel only. Failure to perform installation, start-up, and maintenance by qualified personnel could result in death or serious injury.

⚠ WARNING

UNINTENDED START

When the adjustable frequency drive is connected to AC line power, the motor may start at any time. The adjustable frequency drive, motor, and any driven equipment must be in operational readiness. Failure to be in operational readiness when the adjustable frequency drive is connected to AC line power could result in death, serious injury, equipment, or property damage.

⚠ WARNING

DISCHARGE TIME

Adjustable frequency drives contain DC link capacitors that can remain charged even when the adjustable frequency drive is not powered. To avoid electrical hazards, disconnect AC line power, any permanent magnet type motors, and any remote DC link power supplies, including battery backups, UPS and DC link connections to other adjustable frequency drives. Wait for the capacitors to fully discharge before performing any service or repair work. The wait time required is listed in the *Discharge Time* table. Failure to wait for the specified period of time after power has been removed to do service or repair could result in death or serious injury.

Voltage [V]	Power range hp [kW]	Minimum waiting time [min]
3x200	0.34–5 [0.25–3.7]	4
3x200	7.5–60 [5.5–45]	15
3x400	5–10 [0.37–7.5]	4
3x400	15–125 [11–90]	15
3x600	3–10 [2.2–7.5]	4
3x600	15–125 [11–90]	15

Table 2.1 Discharge Time

2.1.2 Disposal Instruction

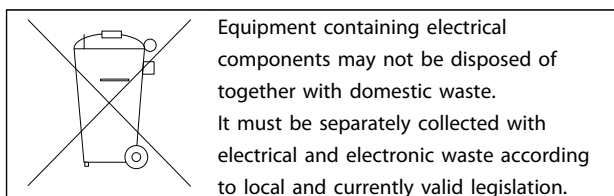

2.2 CE Labeling

2.2.1 CE Conformity and Labeling

What is CE Conformity and Labeling?

The purpose of CE-labeling is to avoid technical trade obstacles within EFTA and the EU. The EU has introduced the CE label as a simple way of showing whether a product complies with the relevant EU directives. The CE label says nothing about the specifications or quality of the product. Adjustable frequency drives are regulated by three EU directives:

The machinery directive (98/37/EEC)

All machines with critical moving parts are covered by the machinery directive of January 1, 1995. Since an adjustable frequency drive is largely electrical, it does not fall under the Machinery Directive. However, if an adjustable frequency drive is supplied for use in a machine, Danfoss provides information on safety aspects relating to the adjustable frequency drive. Danfoss do this by means of a manufacturer's declaration.

The low-voltage directive (73/23/EEC)

Adjustable frequency drives must be CE-labeled in accordance with the Low-voltage Directive of January 1, 1997. The directive applies to all electrical equipment and appliances used in the 50–1,000 V AC and the 75–1,500 V DC voltage ranges. Danfoss CE labels in accordance with the directive and issues a declaration of conformity upon request.

The EMC directive (89/336/EEC)

EMC is short for electromagnetic compatibility. The presence of electromagnetic compatibility means that the mutual interference between different components/appliances does not affect the way the appliances work. The EMC directive came into effect January 1, 1996. Danfoss CE labels in accordance with the directive and issues a declaration of conformity upon request. To carry out EMC-compatible installation, see the instructions in this Design Guide. In addition, Danfoss specifies which standards our products comply with. Danfoss offers the filters presented in the specifications and provides other types of assistance to ensure the optimum EMC result.

The adjustable frequency drive is most often used by professionals of the trade as a complex component forming part of a larger appliance, system or installation. It must be noted that the responsibility for the final EMC properties of the appliance, system or installation rests with the installer.

2.2.2 What is Covered

The "Guidelines on the Application of Council Directive 89/336/EEC" issued by the EU outline three typical situations for using an adjustable frequency drive. See chapter 2.2.3 *Danfoss Adjustable Frequency Drive and CE-Labeling* for EMC coverage and CE labeling.

1. The adjustable frequency drive is sold directly to the end-consumer. The adjustable frequency drive is, for example, sold to a DIY market. The end-consumer is a layman. He installs the adjustable frequency drive himself for use with a hobby machine, a kitchen appliance, etc. For such applications, the adjustable frequency drive must be CE-labeled in accordance with the EMC directive.
2. The adjustable frequency drive is sold for installation in a plant. The plant is assembled by professionals of the trade. It could be a production plant or a heating/ventilation plant designed and installed by professionals of the trade. Neither the adjustable frequency drive nor the finished plant has to be CE-labeled under the EMC directive. However, the unit must comply with the basic EMC requirements of the directive. This is ensured by using components, appliances, and systems that are CE-labeled under the EMC directive.
3. The adjustable frequency drive is sold as part of a complete system. The system is being marketed as complete and could, for example, be an air-conditioning system. The complete system must be CE-labeled in accordance with the EMC directive. The manufacturer can ensure CE-labeling under the EMC directive either by using CE-labeled components or by testing the EMC of the system. If only CE-labeled components are chosen, the entire system does not have to be tested.

2.2.3 Danfoss Adjustable Frequency Drive and CE-Labeling

CE-labeling is a positive feature when used for its original purpose, that is, to facilitate trade within the EU and EFTA.

However, CE-labeling may cover many different specifications. Check what a given CE label specifically covers.

The covered specifications can be very different and a CE label may therefore give the installer a false feeling of security when using an adjustable frequency drive as a component in a system or an appliance.

Danfoss CE-labels the adjustable frequency drives in accordance with the low-voltage directive. This means that if the adjustable frequency drive is installed correctly, Danfoss guarantees compliance with the low-voltage directive. Danfoss issues a declaration of conformity that confirms our CE-labeling in accordance with the low-voltage directive.

The CE label also applies to the EMC directive provided that the instructions for EMC-compatible installation and filtering are followed. On this basis, a declaration of conformity in accordance with the EMC directive is issued.

The Design Guide provides detailed instructions for installation to ensure EMC-compatible installation. Furthermore, Danfoss specifies which of our different products are in compliance.

Danfoss provides other types of assistance that can help to obtain the best EMC result.

2.2.4 Compliance with EMC Directive 89/336/EEC

As mentioned, the adjustable frequency drive is mostly used by professionals of the trade as a complex component forming part of a larger appliance, system or installation. It must be noted that the responsibility for the final EMC properties of the appliance, system or installation rests with the installer. As an aid to the installer, Danfoss has prepared EMC installation guidelines for the Power Drive system. The standards and test levels stated for Power Drive systems are complied with if the EMC-compatible instructions for installation are followed.

2.3 Air Humidity

The adjustable frequency drive has been designed to meet the IEC/EN 60068-2-3 standard, EN 50178 9.4.2.2 at 122 °F [50 °C].

2.4 Aggressive Environments

An adjustable frequency drive contains many mechanical and electronic components. All are to some extent vulnerable to environmental effects.

CAUTION

The adjustable frequency drive should not be installed in environments with airborne liquids, particles or gases capable of affecting and damaging the electronic components. Failure to take the necessary protective measures increases the risk of stoppages, thus reducing the life of the adjustable frequency drive.

Liquids can be carried through the air and condense in the adjustable frequency drive and may cause corrosion of components and metal parts. Steam, oil, and salt water may cause corrosion of components and metal parts. In such environments, use equipment with enclosure rating IP54. As an extra protection, coated printed circuit boards can be ordered as an option. (Standard on some power sizes.)

Airborne particles such as dust may cause mechanical, electrical or thermal failure in the adjustable frequency drive. A typical indicator of excessive levels of airborne particles is the presence of dust particles around the adjustable frequency drive fan. In dusty environments, use equipment with enclosure rating IP54 or a cabinet for IP20/TYPE 1 equipment.

In environments with high temperatures and humidity, corrosive gases such as sulphur, nitrogen, and chlorine compounds causes chemical processes on the adjustable frequency drive components.

Such chemical reactions rapidly affect and damage the electronic components. In such environments, mount the equipment in a cabinet with fresh air ventilation, keeping aggressive gases away from the adjustable frequency drive. An extra protection in such areas is a coating of the printed circuit boards, which can be ordered as an option.

NOTICE

Mounting adjustable frequency drives in aggressive environments increases the risk of stoppages and considerably reduces the life of the adjustable frequency drive.

Before installing the adjustable frequency drive, check the ambient air for liquids, particles and gases. This is done by observing existing installations in this environment. Typical indicators of harmful airborne liquids are water or oil on metal parts, or corrosion of metal parts.

Excessive dust particle levels are often found on installation cabinets and existing electrical installations. One indicator of aggressive airborne gases is the blackening of copper rails and cable ends on existing installations.

2.5 Vibration and Shock

The adjustable frequency drive has been tested according to the procedure based on the shown standards, *Table 2.2*

The adjustable frequency drive complies with requirements that exist for units mounted on the walls and floors of production premises, as well as in panels bolted to walls or floors.

IEC/EN 60068-2-6	Vibration (sinusoidal) - 1970
IEC/EN 60068-2-64	Vibration, broad-band random

Table 2.2 Standards

2.6 Advantages

2.6.1 Why use an adjustable frequency drive for controlling fans and pumps?

An adjustable frequency drive takes advantage of the fact that centrifugal fans and pumps follow the laws of proportionality for such fans and pumps. For further information, see *chapter 2.6.3 Example of Energy Savings*.

2.6.2 The Clear Advantage - Energy Savings

The clear advantage of using an adjustable frequency drive for controlling the speed of fans or pumps lies in the electricity savings.

When comparing with alternative control systems and technologies, an adjustable frequency drive is the optimum energy control system for controlling fan and pump systems.

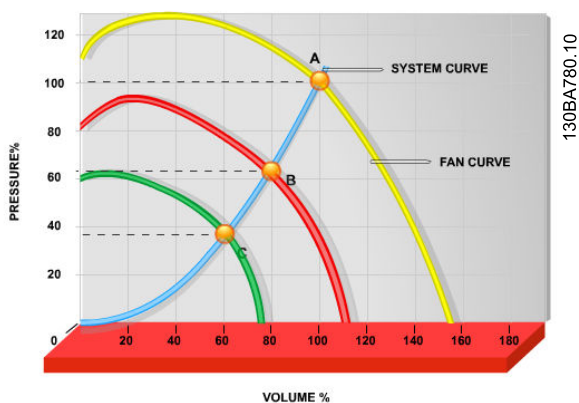

Figure 2.1 Fan Curves (A, B, and C) for Reduced Fan Volumes

If the system in question only needs to be able to supply a flow that corresponds to 100% a few days in a year, while the average is below 80% of the rated flow for the remainder of the year, the amount of energy saved is even more than 50%.

Figure 2.3 describes the dependence of flow, pressure and power consumption on RPM.

Q=Flow	P=Power
Q ₁ =Rated flow	P ₁ =Rated power
Q ₂ =Reduced flow	P ₂ =Reduced power
H=Pressure	n=Speed regulation
H ₁ =Rated pressure	n ₁ =Rated speed
H ₂ =Reduced pressure	n ₂ =Reduced speed

Table 2.3 The Laws of Proportionality

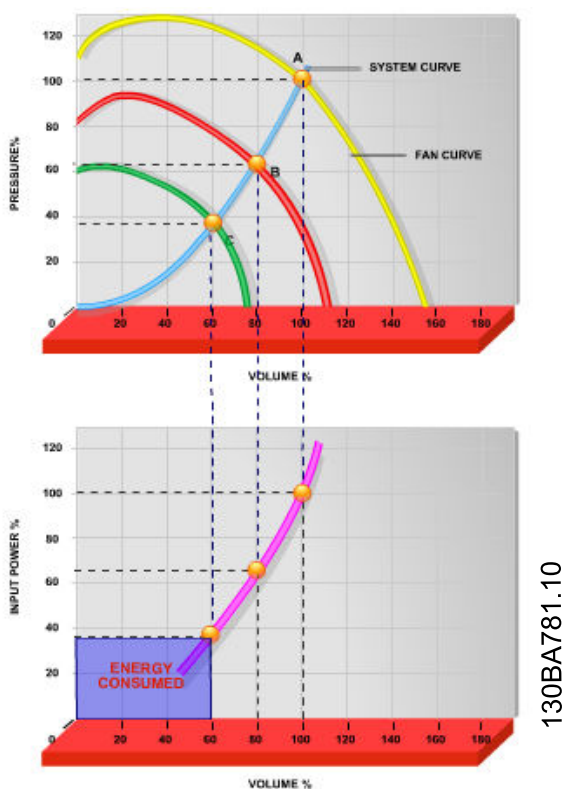

Figure 2.2 When using an adjustable frequency drive to reduce fan capacity to 60%, more than 50% energy savings may be obtained in typical applications.

2.6.3 Example of Energy Savings

As shown in Figure 2.3, the flow is controlled by changing the RPM. By reducing the rated speed by only 20%, the flow is also reduced by 20%. This is because the flow is directly proportional to the RPM. The consumption of electricity, however, is reduced by 50%.

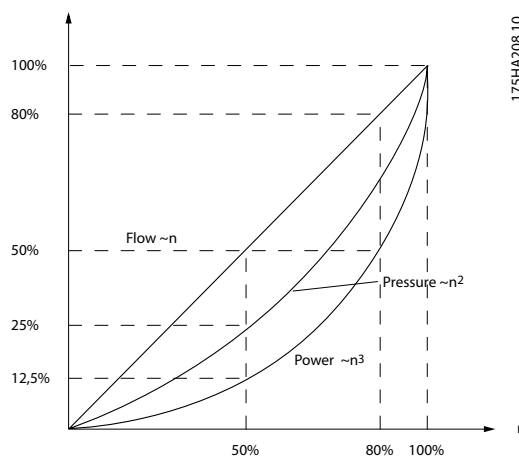

Figure 2.3 Laws of Proportionality

$$\text{Flow: } \frac{Q_1}{Q_2} = \frac{n_1}{n_2}$$

$$\text{Pressure: } \frac{H_1}{H_2} = \left(\frac{n_1}{n_2}\right)^2$$

$$\text{Power: } \frac{P_1}{P_2} = \left(\frac{n_1}{n_2}\right)^3$$

2.6.4 Comparison of Energy Savings

The Danfoss adjustable frequency drive solution offers major savings compared with traditional energy saving solutions. This is because the adjustable frequency drive is able to control fan speed according to thermal load on the system and the fact that the adjustable frequency drive has a built-in facility that enables the adjustable frequency drive to function as a building management system or BMS.

Figure 2.5 shows typical energy savings obtainable with three well-known solutions when fan volume is reduced to, e.g., 60%.

2

As the graph shows, more than 50% energy savings can be achieved in typical applications.

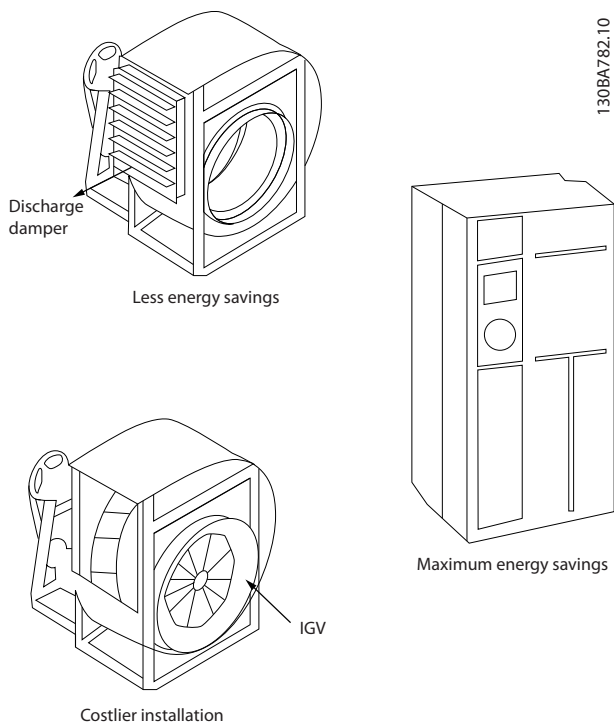

Figure 2.4 The Three Common Energy Saving Systems

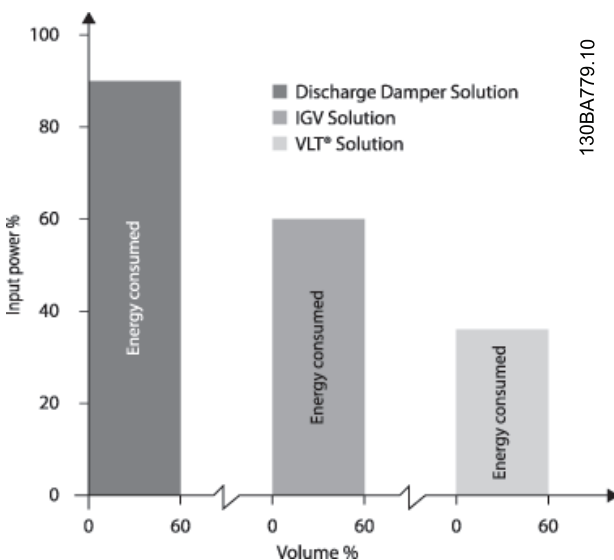

Figure 2.5 Energy Savings

Discharge dampers reduce power consumption somewhat. Inlet guide vans offer a 40% reduction but are expensive to install. The Danfoss adjustable frequency drive solution reduces energy consumption with more than 50% and is easy to install.

2.6.5 Example with Varying Flow over 1 Year

This example is calculated based on pump characteristics obtained from a pump datasheet. The result obtained shows energy savings in excess of 50% at the given flow distribution over a year. The pay back period depends on the price per kWh and price of the adjustable frequency drive. In this example, it is less than a year when compared with valves and constant speed.

Energy savings

$$P_{\text{shaft}} = P_{\text{shaft output}}$$

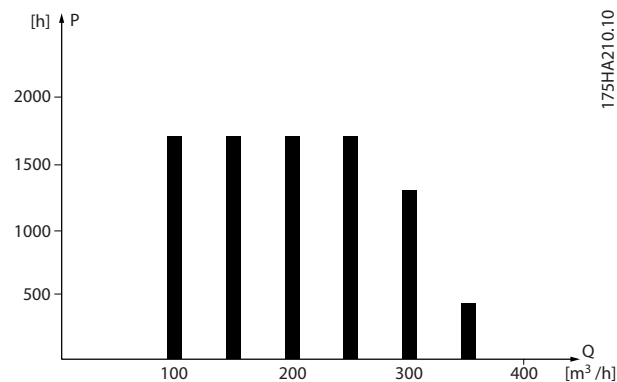

Figure 2.6 Flow Distribution over 1 Year

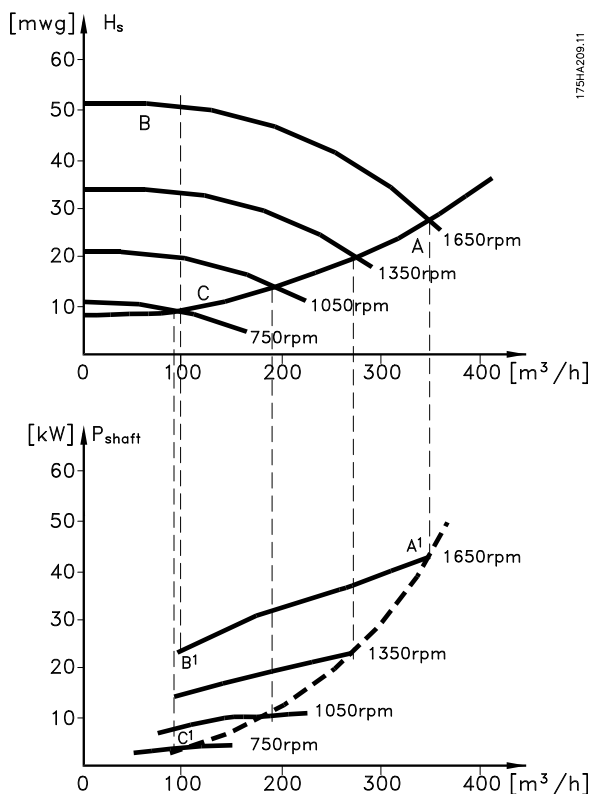

Figure 2.7 Energy

m ³ /h	Distribution		Valve regulation		Adjustable frequency drive control	
	%	Hours	Power	Consumption	Power	Consumption
			A ₁ - B ₁	kWh	A ₁ - C ₁	kWh
350	5	438	42.5	18.615	42.5	18.615
300	15	1314	38.5	50.589	29.0	38.106
250	20	1752	35.0	61.320	18.5	32.412
200	20	1752	31.5	55.188	11.5	20.148
150	20	1752	28.0	49.056	6.5	11.388
100	20	1752	23.0	40.296	3.5	6.132
Σ	100	8760		275.064		26.801

Table 2.4 Result

2.6.6 Better Control

If an adjustable frequency drive is used for controlling the flow or pressure of a system, improved control is obtained. An adjustable frequency drive can vary the speed of the fan or pump, obtaining variable control of flow and pressure.

Furthermore, an adjustable frequency drive can quickly adapt the speed of the fan or pump to new flow or pressure conditions in the system.

Simple control of process (flow, level or pressure) utilizing the built-in PI control.

2.6.7 Star/Delta Starter or Soft Starter not Required

When larger motors are started, it is necessary in many countries to use equipment that limits the start-up current. In more traditional systems, a star/delta starter or soft starter is widely used. Such motor starters are not required if an adjustable frequency drive is used.

As illustrated in Figure 2.8, an adjustable frequency drive does not consume more than rated current.

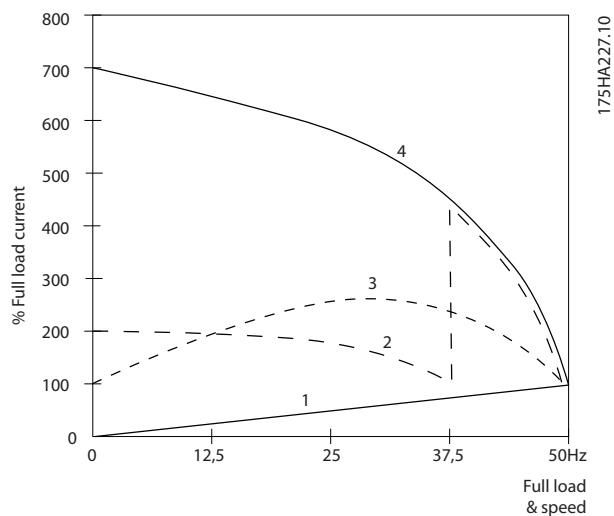

Figure 2.8 Start-up Current

1	VLT® HVAC Basic Drive FC 101
2	Star/delta starter
3	Soft-starter
4	Start directly on line power

Table 2.5 Legend to Figure 2.8

2

2.6.8 Using an Adjustable Frequency Drive Saves Money

Example chapter 2.6.9 Without an Adjustable Frequency Drive shows that a lot of equipment is not required when an adjustable frequency drive is used. It is possible to calculate the cost of installing the two different systems. In the example, the two systems can be established at roughly the same price.

2.6.9 Without an Adjustable Frequency Drive

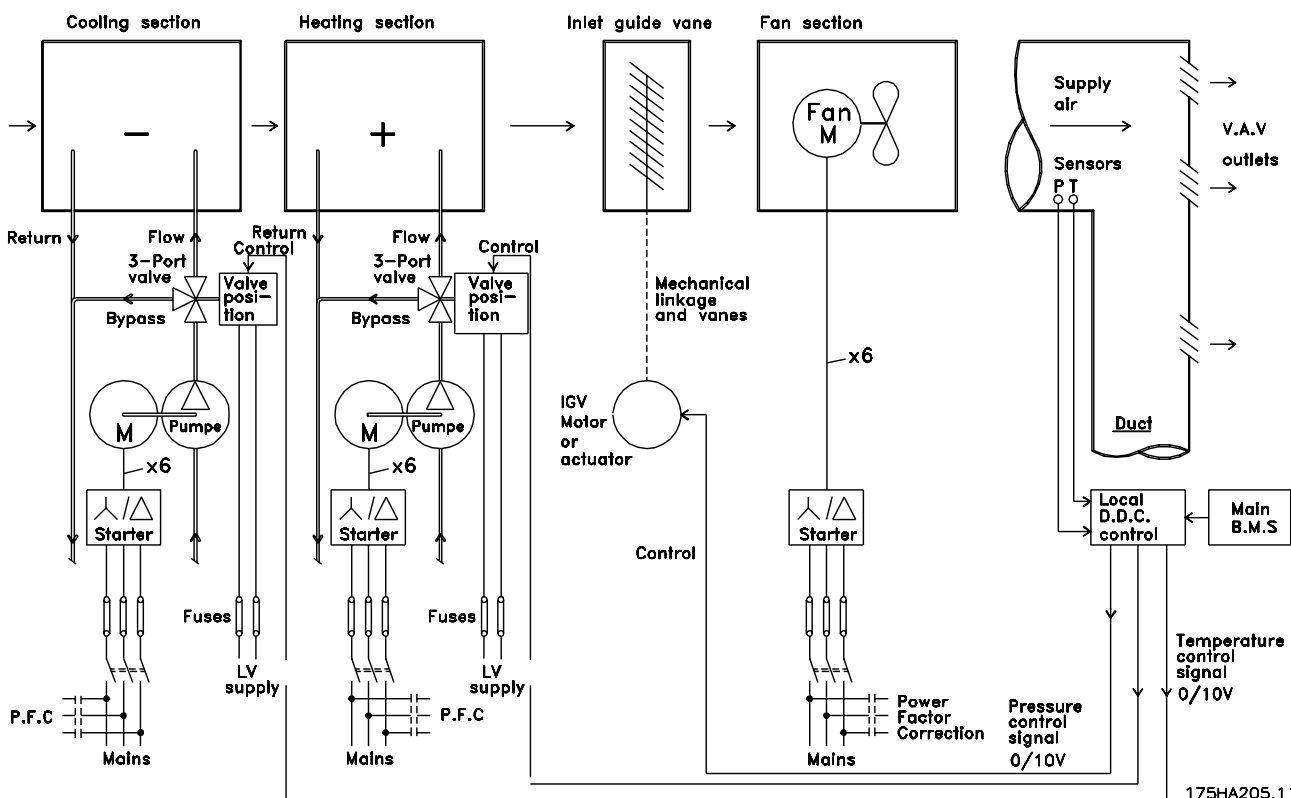

Figure 2.9 Traditional Fan System

D.D.C.	Direct Digital Control
E.M.S.	Energy Management system
V.A.V.	Variable Air Volume
Sensor P	Pressure
Sensor T	Temperature

Table 2.6 Abbreviations used in Figure 2.9

2.6.10 With an Adjustable Frequency Drive

175HA206.11

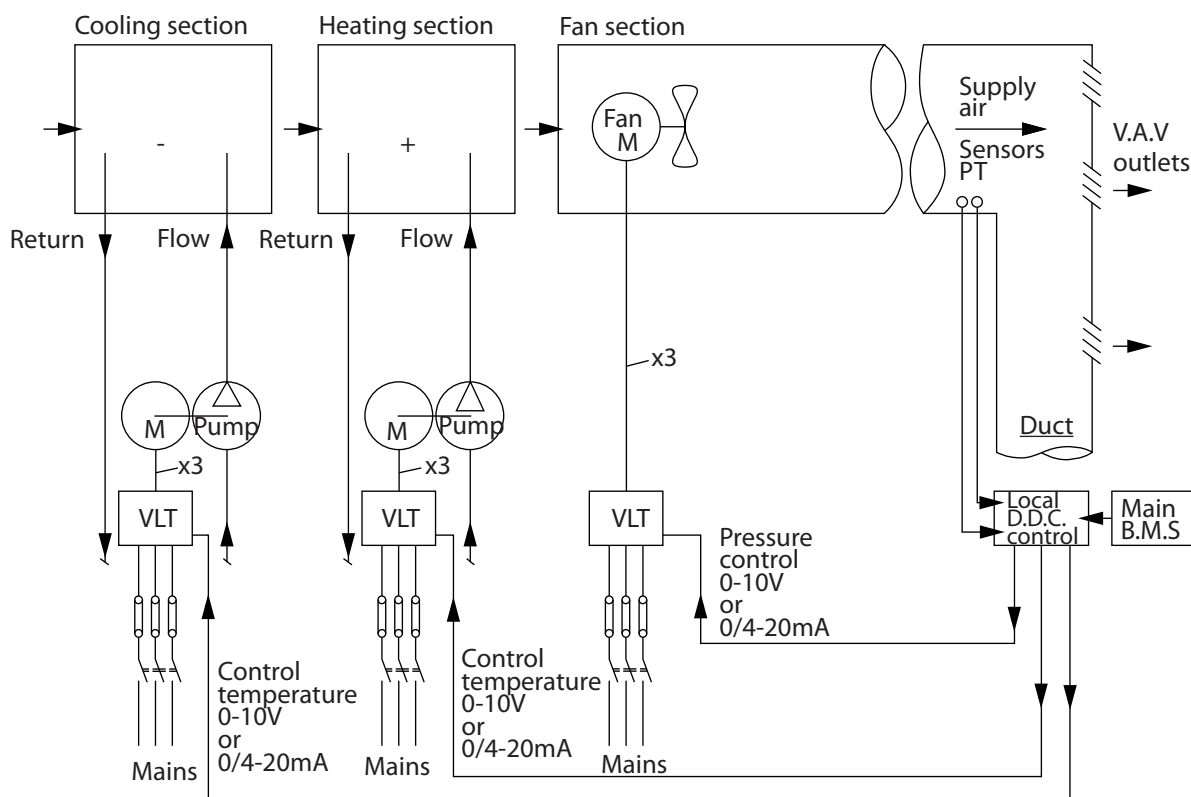

Figure 2.10 Fan System Controlled by Adjustable Frequency Drives

D.D.C.	Direct Digital Control
E.M.S.	Energy Management system
V.A.V.	Variable Air Volume
Sensor P	Pressure
Sensor T	Temperature

Table 2.7 Abbreviations used in Figure 2.10

2.6.11 Application Examples

The next pages provide typical examples of applications within HVAC.

For further information about a given application, ask the Danfoss supplier for an information sheet that gives a full description of the application. The following application notes can be downloaded from the Danfoss web page, www.danfoss.com/BusinessAreas/DrivesSolutions/Documentations/Technical+Documentation.htm.

Variable Air Volume

Ask for *The Drive to...Improving Variable Air Volume Ventilation Systems, MN60A.*

Constant Air Volume

Ask for *The Drive to...Improving Constant Air Volume Ventilation Systems, MN60B.*

Cooling Tower Fan

Ask for *The Drive to...Improving fan control on cooling towers, MN60C.*

Condenser pumps

Ask for *The Drive to...Improving condenser water pumping systems, MN60F.*

Primary pumps

Ask for *The Drive to...Improve your primary pumping in primary/secondary pumping systems, MN60D.*

Secondary pumps

Ask for *The Drive to...Improve your secondary pumping in primary/secondary pumping systems, MN60E.*

2.6.12 Variable Air Volume

VAV or Variable Air Volume systems control both the ventilation and temperature to satisfy the requirements of a building. Central VAV systems are considered to be the most energy efficient method to air condition buildings. By designing central systems instead of distributed systems, greater efficiency can be obtained.

The efficiency comes from utilizing larger fans and larger chillers which have much higher efficiencies than small motors and distributed air-cooled chillers. Savings are also seen from the decreased maintenance requirements.

2.6.13 The VLT Solution

While dampers and IGVs work to maintain a constant pressure in the ductwork, an adjustable frequency drive solution saves much more energy and reduces the complexity of the installation. Instead of creating an artificial pressure drop or causing a decrease in fan efficiency, the adjustable frequency drive decreases the speed of the fan to provide the flow and pressure required by the system.

Centrifugal devices such as fans behave according to the centrifugal laws. This means the fans decrease the pressure and flow they produce as their speed is reduced. Their power consumption is thereby significantly reduced.

The PI controller of the VLT® HVAC Basic Drive can be used to eliminate the need for additional controllers.

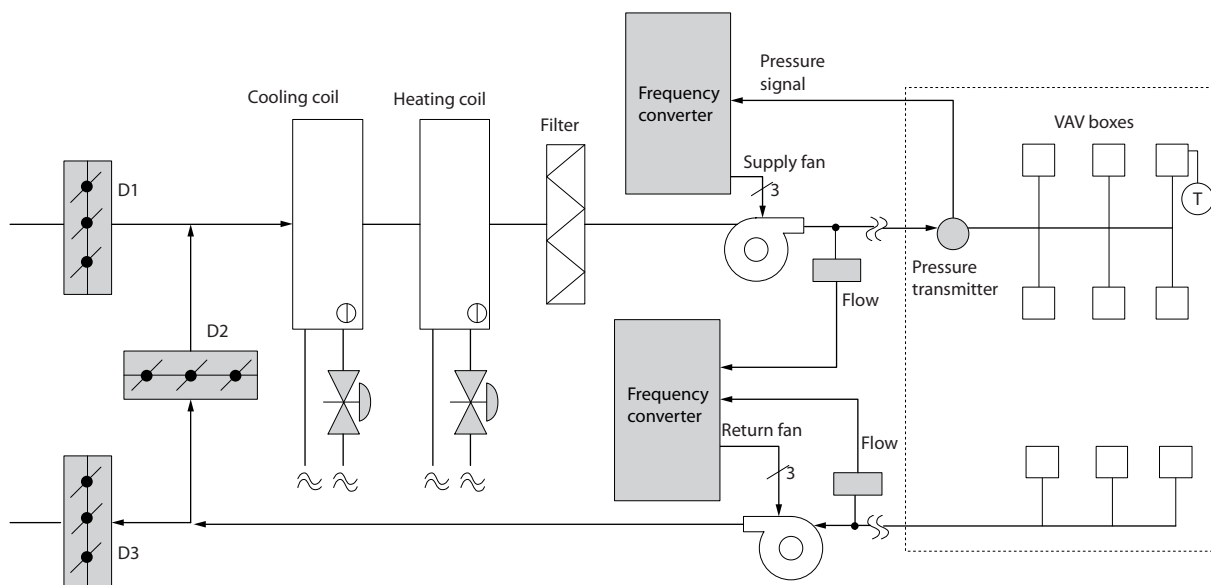

1308B455.10

Figure 2.11 Variable Air Volume

2.6.14 Constant Air Volume

CAV or Constant Air Volume systems are central ventilation systems usually used to supply large common zones with the minimum amounts of fresh tempered air. They preceded VAV systems and are therefore found in older multi-zoned commercial buildings as well. These systems preheat amounts of fresh air utilizing Air Handling Units (AHUs) with a heating coil, and many are also used to air condition buildings and have a cooling coil. Fan coil units are frequently used to assist in the heating and cooling requirements in the individual zones.

2.6.15 The VLT Solution

With an adjustable frequency drive, significant energy savings can be obtained while maintaining decent control of the building. Temperature sensors or CO₂ sensors can be used as feedback signals to adjustable frequency drives. Whether controlling temperature, air quality, or both, a CAV system can be controlled to operate based on actual building conditions. As the number of people in the controlled area decreases, the need for fresh air decreases. The CO₂ sensor detects lower levels and decreases the supply fans speed. The return fan modulates to maintain a static pressure setpoint or fixed difference between the supply and return air flows.

With temperature control (especially used in air conditioning systems), as the outside temperature varies and the number of people in the controlled zone changes, different cooling requirements arise. As the temperature decreases below the setpoint, the supply fan can decrease its speed. The return fan modulates to maintain a static pressure setpoint. By decreasing the air flow, energy used to heat or cool the fresh air is also reduced, adding further savings. Several features of the Danfoss dedicated adjustable frequency drive can be utilized to improve the performance of the CAV system. One concern of controlling a ventilation system is poor air quality. The programmable minimum frequency can be set to maintain a minimum amount of supply air, regardless of the feedback or reference signal. The adjustable frequency drive also includes one PI controller, which allows monitoring both temperature and air quality. Even if the temperature requirement is satisfied, the adjustable frequency drive maintains enough supply air to satisfy the air quality sensor. The controller is capable of monitoring and comparing two feedback signals to control the return fan by maintaining a fixed differential air flow between the supply and return ducts as well.

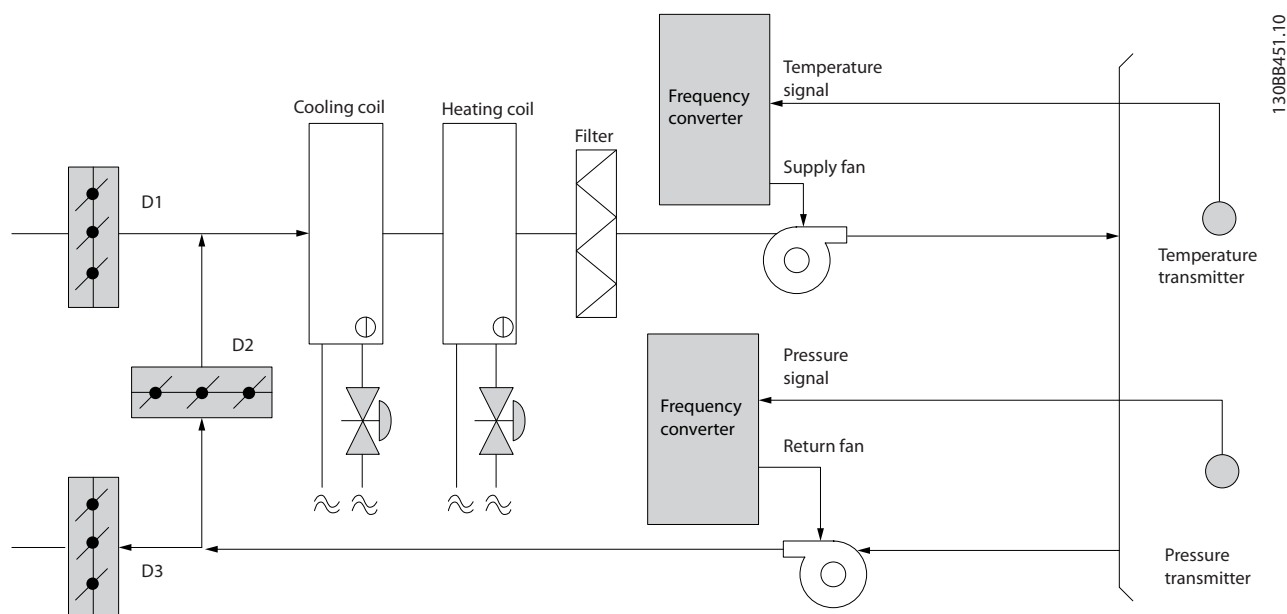

Figure 2.12 Constant Air Volume

2.6.16 Cooling Tower Fan

Cooling tower fans cool condenser water in water-cooled chiller systems. Water-cooled chillers provide the most efficient means of creating chilled water. They are as much as 20% more efficient than air-cooled chillers. Depending on climate, cooling towers are often the most energy efficient method of cooling the condenser water from chillers.

They cool the condenser water by evaporation.

The condenser water is sprayed into the cooling tower until the cooling towers “fill” to increase its surface area. The tower fan blows air through the fill and sprayed water to aid in the evaporation. Evaporation removes energy from the water, thus dropping its temperature. The cooled water collects in the cooling towers basin, where it is pumped back into the chiller's condenser, and the cycle is then repeated.

2.6.17 The VLT Solution

With an adjustable frequency drive, the cooling towers fans can be set to the speed required to maintain the condenser water temperature. The adjustable frequency drives can also be used to turn the fan on and off as needed.

Several features of the Danfoss dedicated adjustable frequency drive, the HVAC adjustable frequency drive can be utilized to improve the performance of cooling tower fans applications. As the cooling tower fans drop below a certain speed, the effect the fan has on cooling the water becomes insignificant. Also, when utilizing a gear box to frequency control the tower fan, a minimum speed of 40–50% may be required.

The customer programmable minimum frequency setting is available to maintain this minimum frequency even as the feedback or speed reference calls for lower speeds.

Also as a standard feature, the adjustable frequency drive can be programmed to enter a “sleep” mode and stop the fan until a higher speed is required. Additionally, some cooling tower fans have undesirable frequencies that may cause vibrations. These frequencies can easily be avoided by programming the bypass frequency ranges in the adjustable frequency drive.

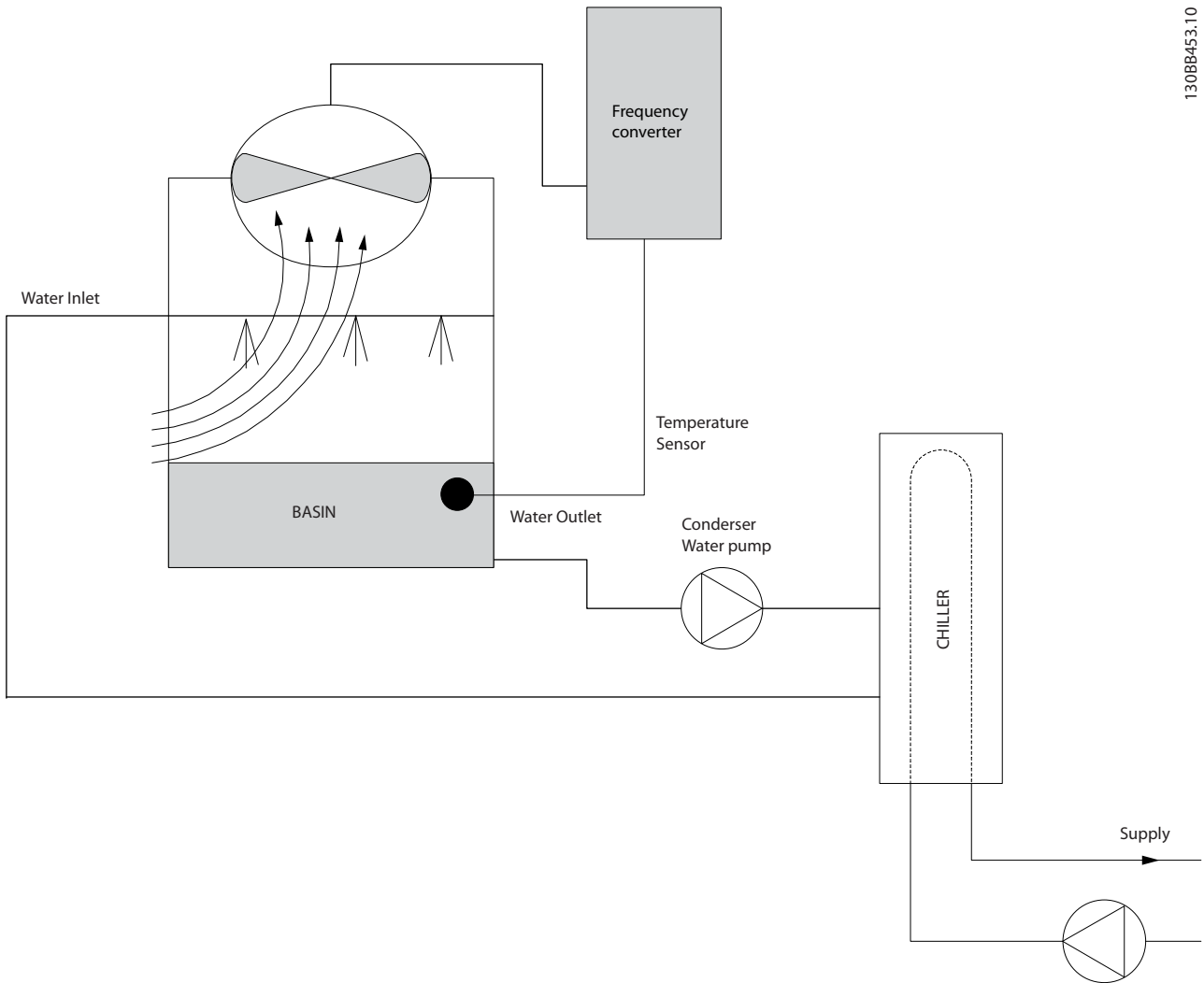

Figure 2.13 Cooling Tower Fan

2

2.6.18 Condenser Pumps

Condenser water pumps are primarily used to circulate water through the condenser section of water cooled chillers and their associated cooling tower. The condenser water absorbs the heat from the chiller's condenser section and releases it into the atmosphere in the cooling tower. These systems are used to provide the most efficient means of creating chilled water, and they are as much as 20% more efficient than air cooled chillers.

2.6.19 The VLT Solution

Adjustable frequency drives can be added to condenser water pumps instead of balancing the pumps with a throttling valve or trimming the pump impeller.

Using an adjustable frequency drive instead of a throttling valve simply saves the energy that would have been absorbed by the valve. This can amount to savings of 15–20% or more. Trimming the pump impeller is irreversible, thus if the conditions change and higher flow is required the impeller must be replaced.

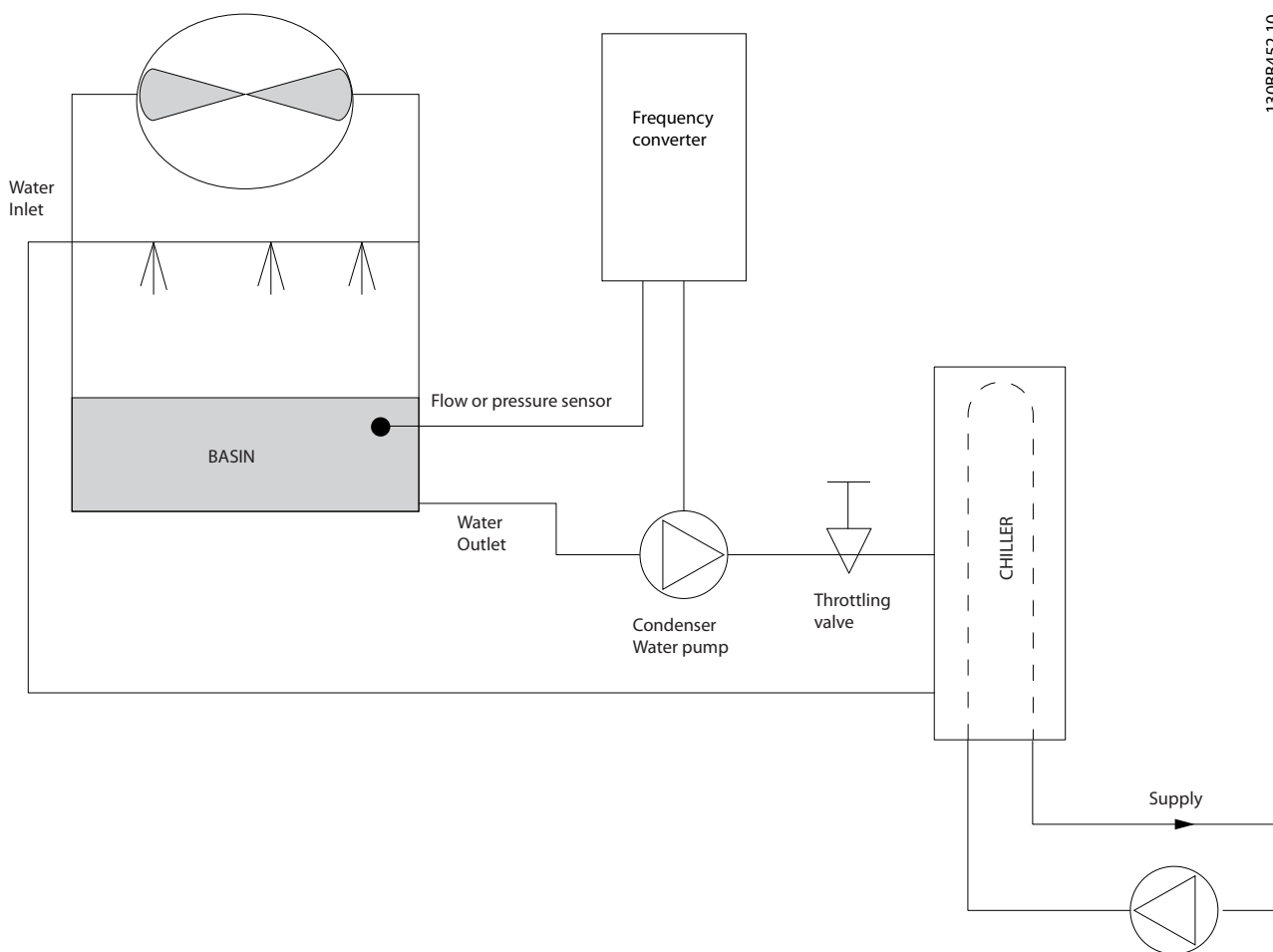

Figure 2.14 Condenser Pumps

2.6.20 Primary Pumps

Primary pumps in a primary/secondary pumping system can be used to maintain a constant flow through devices that encounter operation or control difficulties when exposed to variable flow. The primary/secondary pumping technique decouples the “primary” production loop from the “secondary” distribution loop. This allows devices such as chillers to obtain constant design flow and operate properly while allowing the rest of the system to vary in flow.

As the evaporator flow rate decreases in a chiller, the chilled water begins to become over-chilled. As this happens, the chiller attempts to decrease its cooling capacity. If the flow rate drops far enough, or too quickly, the chiller cannot shed its load sufficiently and the chiller’s safety trips the chiller requiring a manual reset. This situation is common in large installations especially when two or more chillers are installed in parallel if primary/secondary pumping is not utilized.

2.6.21 The VLT Solution

Depending on the size of the system and the size of the primary loop, the energy consumption of the primary loop can become substantial.

An adjustable frequency drive can be added to the primary system to replace the throttling valve and/or trimming of the impellers, leading to reduced operating expenses. Two control methods are common:

Flow meter

Because the desired flow rate is known and constant, a flow meter installed at the discharge of each chiller can be used to control the pump directly. Using the built-in PI controller, the adjustable frequency drive always maintains the appropriate flow rate, even compensating for the changing resistance in the primary piping loop as chillers and their pumps are staged on and off.

Local speed determination

The operator simply decreases the output frequency until the design flow rate is achieved.

Using an adjustable frequency drive to decrease the pump speed is very similar to trimming the pump impeller, except it does not require any labor and the pump efficiency remains higher. The balancing contractor simply decreases the speed of the pump until the proper flow rate is achieved and leaves the speed fixed. The pump operates at this speed any time the chiller is staged on. Because the primary loop does not have control valves or other devices that can cause the system curve to change and the variance due to staging pumps and chillers on and off is usually small, this fixed speed remains appropriate. In the event the flow rate needs to be increased later in the life of the system, the adjustable frequency drive can simply increase the pump speed instead of requiring a new pump impeller.

2.6.22 Secondary Pumps

Secondary pumps in a primary/secondary chilled water pumping system distribute the chilled water to the loads from the primary production loop. The primary/secondary pumping system is used to hydraulically de-couple one piping loop from another. In this case, the primary pump is used to maintain a constant flow through the chillers while allowing the secondary pumps to vary in flow, increase control and save energy.

If the primary/secondary design concept is not used and a variable volume system is designed, the chiller cannot shed its load properly when the flow rate drops far enough or too quickly. The chiller's low evaporator temperature safety then trips the chiller, requiring a manual reset. This situation is common in large installations, especially when two or more chillers are installed in parallel.

2.6.23 The VLT Solution

While the primary-secondary system with two-way valves improves energy savings and eases system control problems, the true energy savings and control potential is realized by adding adjustable frequency drives.

With the proper sensor location, the addition of adjustable frequency drives allows the pumps to vary their speed to follow the system curve instead of the pump curve.

This results in the elimination of wasted energy and eliminates most of the over-pressurization to which two-way valves can be subjected.

As the monitored loads are reached, the two-way valves close down. This increases the differential pressure measured across the load and two-way valve. As this differential pressure starts to rise, the pump is slowed to maintain the control head also called setpoint value. This setpoint value is calculated by summing the pressure drop of the load and two-way valve together under design conditions.

NOTICE!

When running multiple pumps in parallel, they must run at the same speed to maximize energy savings, either with individual dedicated drives or one adjustable frequency drive running multiple pumps in parallel.

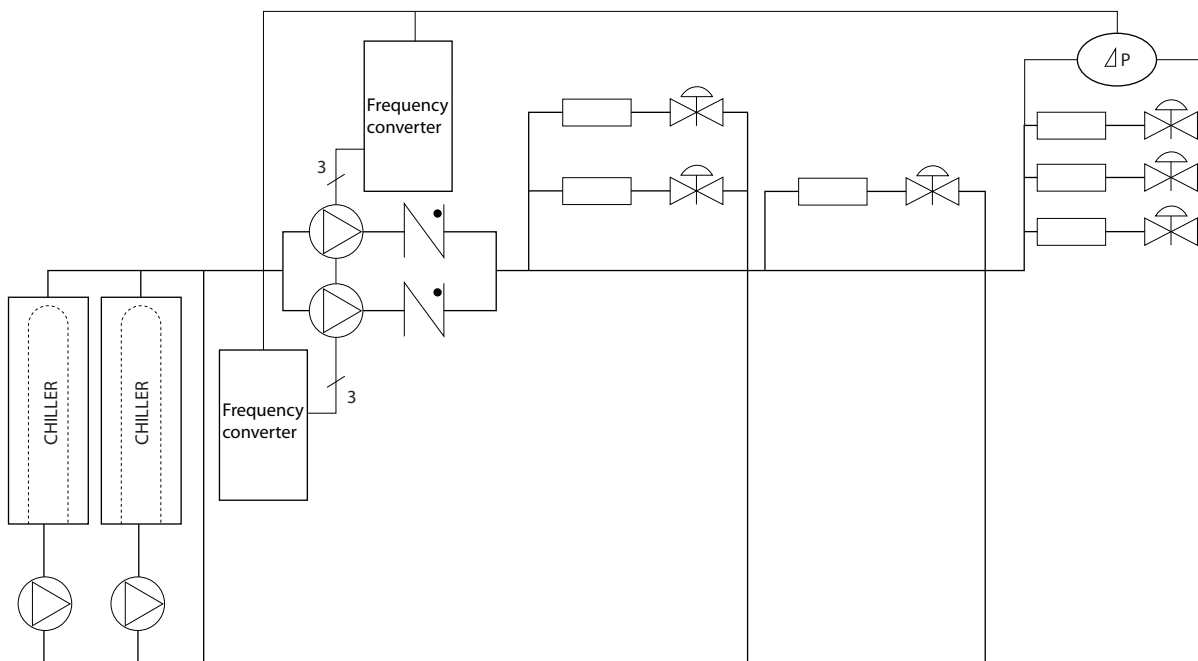

1308B454.10

Figure 2.16 Secondary Pumps

2.7 Control Structures

2.7.1 Control Principle

1-00 Configuration Mode can be selected if open-loop or closed-loop is to be used.

2.7.2 Control Structure Open-loop

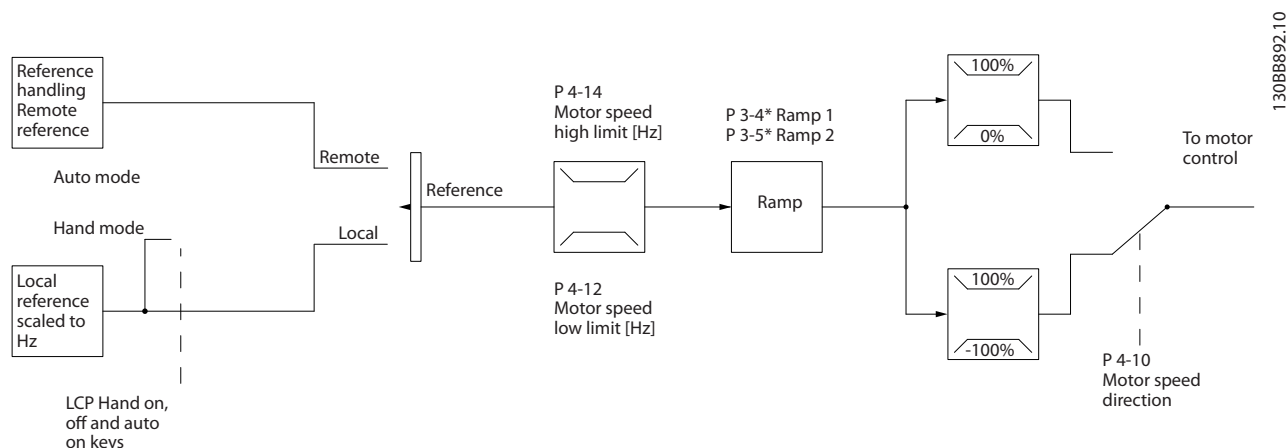

Figure 2.17 Open-loop Structure

In the configuration shown in *Figure 2.17*, 1-00 Configuration Mode is set to [0] Open-loop. The resulting reference from the reference handling system or the local reference is received and fed through the ramp limitation and speed limitation before being sent to the motor control. The output from the motor control is then limited by the maximum frequency limit.

2.7.3 PM/EC+ Motor Control

The Danfoss EC+ concept provides the possibility for using high efficient PM motors (permanent magnet motors) in IEC standard frame size operated by Danfoss adjustable frequency drives.

The commissioning procedure is comparable to the existing one for asynchronous (induction) motors by utilizing the Danfoss VVC^{plus} PM control strategy.

Customer advantages:

- Free choice of motor technology (permanent magnet or induction motor)
- Installation and operation as known on induction motors
- Manufacturer independent when selecting system components (e.g., motors)
- Best system efficiency by selecting best components
- Possible retrofit of existing installations
- Power range: 45 kW (200 V), 0.37–90 kW (400 V), 90 kW (600 V) for induction motors and 0.37–22 kW (400 V) for PM motors

Current limitations for PM motors:

- Currently only supported up to 22 kW
- Currently limited to non-salient type PM motors
- LC filters not supported together with PM motors
- Overvoltage control algorithm is not supported with PM motors
- Kinetic backup algorithm is not supported with PM motors
- Support reduced AMA of the stator resistance R_s in the system only
- No stall detection
- No ETR function

2.7.4 Local (Hand On) and Remote (Auto On) Control

The adjustable frequency drive can be operated manually via the local control panel (LCP) or remotely via analog/digital inputs or serial bus. If allowed in *0-40 [Hand on] Key on LCP*, *0-44 [Off/Reset] Key on LCP*, and *0-42 [Auto on] Key on LCP*, it is possible to start and stop the adjustable frequency drive by LCP using the [Hand On] and [Off/Reset] keys. Alarms can be reset via the [Off/Reset] key.

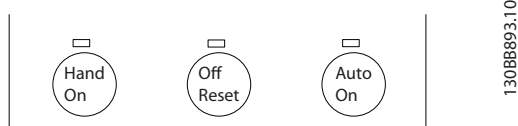

Figure 2.18 LCP Keys

Local reference forces the configuration mode to open-loop, independent on the setting of *1-00 Configuration Mode*.

Local Reference is restored at power-down.

2.7.5 Control Structure Closed-loop

The internal controller allows the adjustable frequency drive to become an integral part of the controlled system. The adjustable frequency drive receives a feedback signal from a sensor in the system. It then compares this feedback to a setpoint reference value and determines the error, if any, between these two signals. It then adjusts the speed of the motor to correct this error.

For example, consider a pump application where the speed of a pump is to be controlled so that the static pressure in a pipe is constant. The desired static pressure value is supplied to the adjustable frequency drive as the setpoint reference. A static pressure sensor measures the actual static pressure in the pipe and supplies this to the adjustable frequency drive as a feedback signal. If the feedback signal is greater than the setpoint reference, the adjustable frequency drive slows down to reduce the pressure. In a similar way, if the pipe pressure is lower than the setpoint reference, the adjustable frequency drive automatically speed up to increase the pressure provided by the pump.

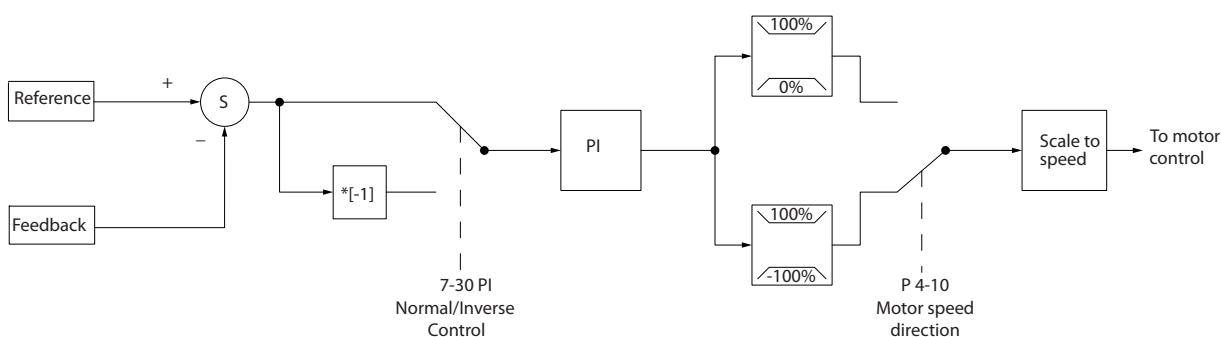

Figure 2.19 Control Structure Closed-loop

While the default values for the adjustable frequency drive’s closed-loop controller often provides satisfactory performance, the control of the system can often be optimized by adjusting some of the closed-loop controller’s parameters.

2.7.6 Feedback Conversion

In some applications, it may be useful to convert the feedback signal. One example of this is using a pressure signal to provide flow feedback. Since the square root of pressure is proportional to flow, the square root of the pressure signal yields a value proportional to the flow. See Figure 2.20.

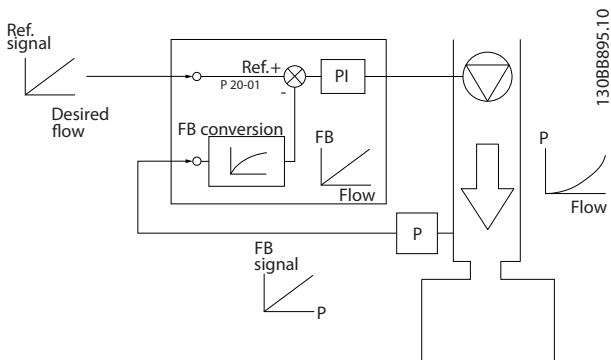

Figure 2.20 Feedback Signal Conversion

2.7.7 Reference Handling

Details for Open-loop and Closed-loop Operation

1308B9001.3

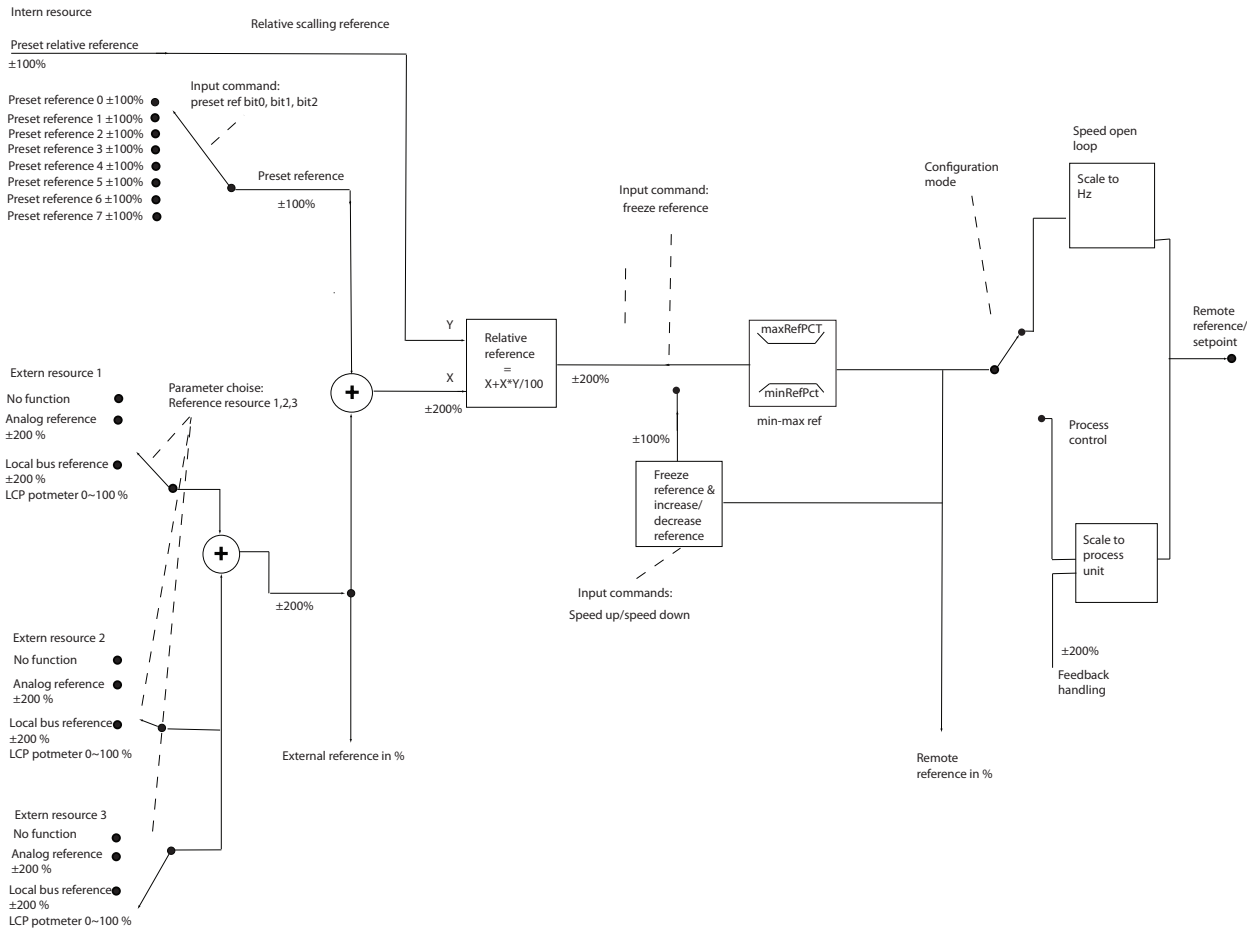

Figure 2.21 Block Diagram Showing Remote Reference

The remote reference is comprised of:

- Preset references
- External references (analog inputs and serial communication bus references)
- The preset relative reference
- Feedback controlled setpoint

Up to eight preset references can be programmed in the adjustable frequency drive. The active preset reference can be selected using digital inputs or the serial communications bus. The reference can also be supplied externally, most commonly from an analog input. This external source is selected by one of the three Reference Source parameters (3-15 *Reference 1 Source*, 3-16 *Reference 2 Source* and 3-17 *Reference 3 Source*). All reference resources and the bus reference are added to produce the total external reference. The external reference, the preset reference or the sum of the two can be selected to be the active reference. Finally, this reference can be scaled by using 3-14 *Preset Relative Reference*.

The scaled reference is calculated as follows:

$$\text{Reference} = X + X \times \left(\frac{Y}{100}\right)$$

Where X is the external reference, the preset reference or the sum of these and Y is 3-14 *Preset Relative Reference* in [%].

If Y, 3-14 *Preset Relative Reference*, is set to 0%, the reference is not affected by the scaling.

2.7.8 Closed-loop Set-up Wizard

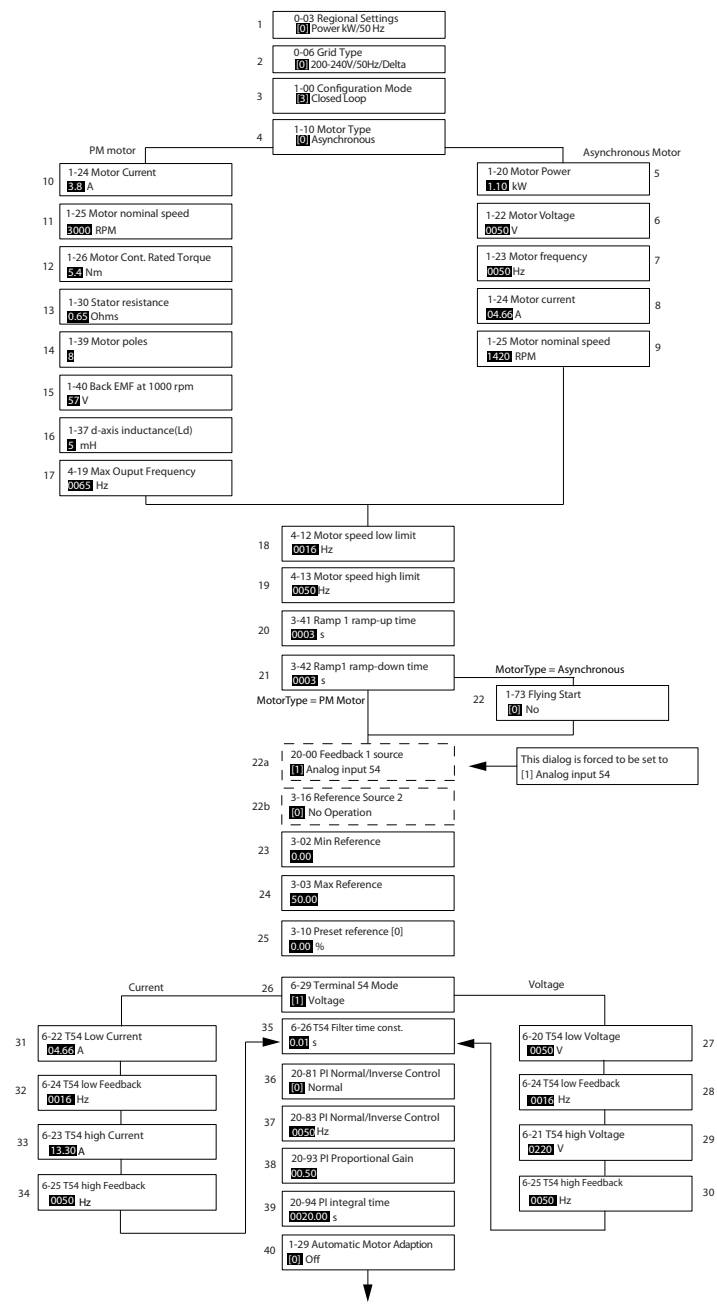

Figure 2.22 Closed-loop Set-up Wizard

Closed-loop Set-up Wizard

Parameter	Range	Default	Function
0-03 Regional Settings	[0] International [1] US	0	
0-06 GridType	[0] -[[132] see start-up wizard for open-loop application	Size selected	Select operating mode for restart upon reconnection of the adjustable frequency drive to AC line voltage after power-down.
1-00 Configuration Mode	[0] Open-loop [3] Closed-loop	0	Change this parameter to Closed-loop.
1-10 Motor Construction	*[0] Motor construction [1] PM, non-salient SPM	[0] Asynchron	Setting the parameter value might change these parameters: 1-01 Motor Control Principle 1-03 Torque Characteristics 1-14 Damping Gain 1-15 Low Speed Filter Time Const 1-16 High Speed Filter Time Const 1-17 Voltage filter time const 1-20 Motor Power 1-22 Motor Voltage 1-23 Motor Frequency 1-25 Motor Nominal Speed 1-26 Motor Cont. Rated Torque 1-30 Stator Resistance (Rs) 1-33 Stator Leakage Reactance (X1) 1-35 Main Reactance (Xh) 1-37 d-axis Inductance (Ld) 1-39 Motor Poles 1-40 Back EMF at 1000 RPM 1-66 Min. Current at Low Speed 1-72 Start Function 1-73 Flying Start 4-19 Max Output Frequency 4-58 Missing Motor Phase Function
1-20 Motor Power	0.09–110 kW	Size related	Enter motor power from nameplate data.
1-22 Motor Voltage	50.0–1000.0 V	Size related	Enter motor voltage from nameplate data.
1-23 Motor Frequency	20.0–400.0 Hz	Size related	Enter motor frequency from nameplate data.
1-24 Motor Current	0.0–10000.00 A	Size related	Enter motor current from nameplate data.
1-25 Motor Nominal Speed	100.0–9999.0 RPM	Size related	Enter motor nominal speed from nameplate data.
1-26 Motor Cont. Rated Torque	0.1–1000.0	Size related	This parameter is available only when 1-10 Motor Construction Design is set to [1] PM, non-salient SPM. NOTICE! Changing this parameter affects the settings of other parameters.
1-29 Automatic Motor Adaption (AMA)		Off	Performing an AMA optimizes motor performance.
1-30 Stator Resistance (Rs)	0.000–99.990	Size related	Set the stator resistance value.

Parameter	Range	Default	Function
1-37 d-axis Inductance (Ld)	0–1000	Size related	Enter the value of the d-axis inductance. Obtain the value from the permanent magnet motor data sheet. The de-axis inductance cannot be found by performing an AMA.
1-39 Motor Poles	2–100	4	Enter the number of motor pole.
1-40 Back EMF at 1000 RPM	10–9000	Size related	Line-Line RMS back EMF voltage at 1000 RPM
1-73 Flying Start	[0] Disabled [1] Enabled	0	Select [1] <i>Enable</i> to enable the adjustable frequency drive to catch a spinning motor, e.g., in fan applications. When PM is selected, Flying Start is enabled.
3-02 Minimum Reference	-4999–4999	0	The minimum reference is the lowest value obtainable by summing all references.
3-03 Maximum Reference	-4999–4999	50	The maximum reference is the highest value obtainable by summing all references.
3-10 Preset Reference	-100–100%	0	Enter the setpoint.
3-41 Ramp 1 Ramp Up Time	0.05–3600.0 s	Size related	Ramp-up time from 0 to rated 1-23 <i>Motor Frequency</i> if Asynchron motor is selected; ramp-up time from 0 to 1-25 <i>Motor Nominal Speed</i> if PM motor is selected.
3-42 Ramp 1 Ramp Down Time	0.05–3600.0 s	Size related	Ramp-down time from rated 1-23 <i>Motor Frequency</i> to 0 if Asynchron motor is selected; ramp-down time from 1-25 <i>Motor Nominal Speed</i> to 0 if PM motor is selected.
4-12 Motor Speed Low Limit [Hz]	0.0–400 Hz	0.0 Hz	Enter the minimum limit for low speed.
4-14 Motor Speed High Limit [Hz]	0–400 Hz	65 Hz	Enter the minimum limit for high speed.
4-19 Max Output Frequency	0–400	Size related	Enter the maximum output frequency value.
6-20 Terminal 54 Low Voltage	0–10 V	0.07 V	Enter the voltage that corresponds to the low reference value.
6-21 Terminal 54 High Voltage	0–10 V	10 V	Enter the voltage that corresponds to the low high reference value.
6-22 Terminal 54 Low Current	0–20 mA	4	Enter the current that corresponds to the high reference value.
6-23 Terminal 54 High Current	0–20 mA	20	Enter the current that corresponds to the high reference value.
6-24 Terminal 54 Low Ref./Feedb. Value	-4999–4999	0	Enter the feedback value that corresponds to the voltage or current set in 6-20 <i>Terminal 54 Low Voltage</i> /6-22 <i>Terminal 54 Low Current</i>
6-25 Terminal 54 High Ref./Feedb. Value	-4999–4999	50	Enter the feedback value that corresponds to the voltage or current set in 6-21 <i>Terminal 54 High Voltage</i> /6-23 <i>Terminal 54 High Current</i>
6-26 Terminal 54 Filter Time Constant	0–10 s	0.01	Enter the filter time constant.
6-29 Terminal 54 mode	[0] Current [1] Voltage	1	Select if terminal 54 is used for current or voltage input.
20-81 PI Normal/ Inverse Control	[0] Normal [1] Inverse	0	Select [0] <i>Normal</i> to set the process control to increase the output speed when the process error is positive. Select [1] <i>Inverse</i> to reduce the output speed.
20-83 PI Start Speed [Hz]	0–200 Hz	0	Enter the motor speed to be attained as a start signal for commencement of PI control.

Parameter	Range	Default	Function
20-93 PI Proportional Gain	0–10	0.01	Enter the process controller proportional gain. Quick control is obtained at high amplification. However, if amplification is too great, the process may become unstable.
20-94 PI Integral Time	0.1–999.0 s	999.0 s	Enter the process controller integral time. Obtain quick control through a short integral time, though if the integral time is too short, the process becomes unstable. An excessively long integral time disables the integral action.

Table 2.8 Closed-loop Set-up Wizard

2.7.9 Tuning the Drive Closed-loop Controller

Once the adjustable frequency drive's closed-loop controller has been set up, the performance of the controller should be tested. In many cases, its performance may be acceptable using the default values of *20-93 PI Proportional Gain* and *20-94 PI Integral Time*. However, in some cases it may be helpful to optimize these parameter values to provide faster system response while still controlling speed overshoot.

2.7.10 Manual PI Adjustment

1. Start the motor.
2. Set *20-93 PI Proportional Gain* to 0.3 and increase it until the feedback signal begins to oscillate. If necessary, start and stop the adjustable frequency drive or make step changes in the setpoint reference to attempt to cause oscillation. Next reduce the PI proportional gain until the feedback signal stabilizes. Then reduce the proportional gain by 40–60%.
3. Set *20-94 PI Integral Time* to 20 s and reduce it until the feedback signal begins to oscillate. If necessary, start and stop the adjustable frequency drive or make step changes in the setpoint reference to attempt to cause oscillation. Next, increase the PI integral time until the feedback signal stabilizes. Then increase of the integral time by 15–50%.

2.8 General Aspects of EMC

Electrical interference is usually conducted at frequencies in the range 150 kHz to 30 MHz. Airborne interference from the adjustable frequency drive system in the range 30 MHz to 1 GHz is generated from the inverter, motor cable, and the motor.

As shown in *Figure 2.23*, capacitive currents in the motor cable coupled with a high dU/dt from the motor voltage generate leakage currents.

The use of a shielded motor cable increases the leakage current (see *Figure 2.23*) because shielded cables have higher capacitance to ground than non-shielded cables. If the leakage current is not filtered, it causes greater interference on the line power in the radio frequency range below approximately 5 MHz. Since the leakage current (I_1) is carried back to the unit through the shielding (I_3), there will in principle only be a small electro-magnetic field (I_4) from the shielded motor cable according to the figure below.

The shield reduces the radiated interference, but increases the low-frequency interference in the line power supply. The motor cable screen must be connected to the adjustable frequency drive enclosure as well as to the motor enclosure. This is best done by using integrated shield clamps so as to avoid twisted shield ends (pigtailed). These increase the shield impedance at higher frequencies, which reduces the shield effect and increases the leakage current (I_4).

If a shielded cable is used for serial communication bus, relay, control cable, signal interface and brake, the shield must be mounted on the enclosure at both ends. In some situations, however, it is necessary to break the shield to avoid current loops.

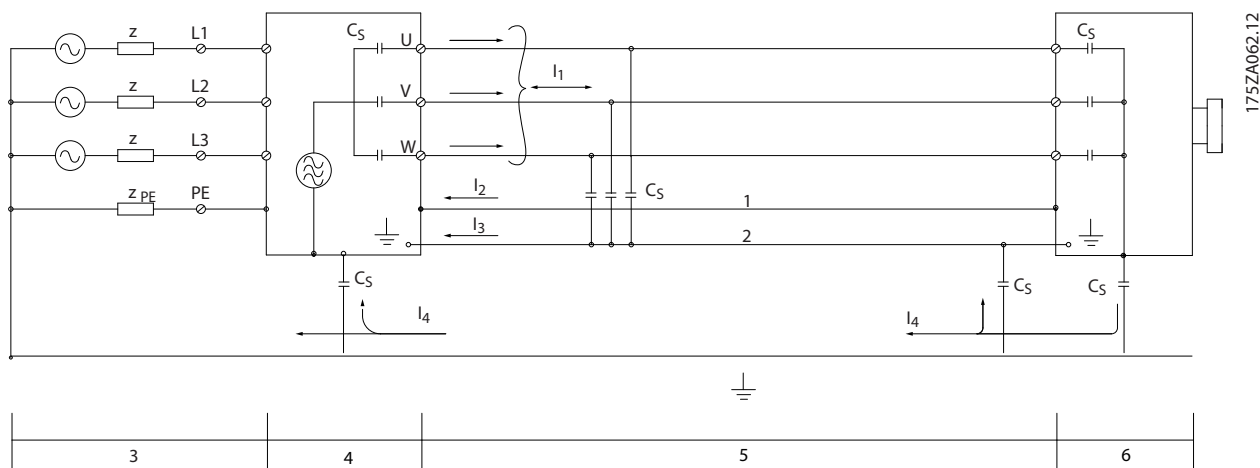

Figure 2.23 Situation that Generates Leakage Currents

If the shield is to be placed on a mounting plate for the adjustable frequency drive, the mounting plate must be made of metal, because the shield currents have to be conveyed back to the unit. Moreover, ensure good electrical contact from the mounting plate through the mounting screws to the adjustable frequency driver chassis.

When non-shielded cables are used, some emission requirements are not complied with, although the immunity requirements are observed.

In order to reduce the interference level from the entire system (unit+installation), make motor and brake cables as short as possible. Avoid placing cables with a sensitive signal level alongside motor and brake cables. Radio interference higher than 50 MHz (airborne) is especially generated by the control electronics. See *chapter 5.2.4 EMC-compatible Electrical Installation* for more information on EMC.

2.8.1 Emission Requirements

According to the EMC product standard for adjustable frequency drives, EN/IEC 61800-3:2004 the EMC requirements depend on the intended use of the adjustable frequency drive. The EMC product standard defines four categories. The four categories and the requirements for line power supply voltage conducted emissions are defined in *Table 2.9*.

Category	Definition	Conducted emission requirement according to the limits given in EN 55011
C1	Adjustable frequency drives installed in the first environment (home and office) with a supply voltage less than 1000 V.	Class B
C2	Adjustable frequency drives installed in the first environment (home and office) with a supply voltage less than 1000 V, which are neither plug-in nor movable and are intended to be installed and commissioned by a professional.	Class A Group 1
C3	Adjustable frequency drives installed in the second environment (industrial) with a supply voltage lower than 1000 V.	Class A Group 2
C4	Adjustable frequency drives installed in the second environment with a supply voltage equal to or above 1000 V or rated current equal to or above 400 A or intended for use in complex systems.	No limit line. An EMC plan should be made.

Table 2.9 Emission Requirements

When the generic (conducted) emission standards are used, the adjustable frequency drives are required to comply with the following limits

Environment	Generic standard	Conducted emission requirement according to the limits given in EN 55011
First environment (home and office)	EN/IEC 61000-6-3 Emission standard for residential, commercial and light industrial environments.	Class B
Second environment (industrial environment)	EN/IEC 61000-6-4 Emission standard for industrial environments.	Class A Group 1

Table 2.10 Limits at Generic Emission Standards

2.8.2 EMC Test Results

The following test results have been obtained using a system with an adjustable frequency drive, a shielded control cable, a control box with potentiometer, as well as a motor shielded cable.

RFI Filter Type	Conduct emission. Maximum shielded cable length [m]						Radiated emission			
	Industrial environment				Housing, trades and light industries		Industrial environment		Housing, trades and light industries	
	EN 55011 Class A2		EN 55011 Class A1		EN 55011 Class B		EN 55011 Class A1		EN 55011 Class B	
	Without external filter	With external filter	Without external filter	With external filter	Without external filter	With external filter	Without external filter	With external filter	Without external filter	With external filter
H4 RFI filter (Class A1)										
0.34–15 hp [0.25–11 kW] 3x200– 240 V IP20			25	50		20	Yes	Yes		No
0.5–30 hp [0.37–22 kW] 3x380– 480 V IP20			25	50		20	Yes	Yes		No
H2 RFI filter (Class A2)										
20–60 hp [15–45 kW] 3x200– 240 V IP20	25						No		No	
40–125 hp [30–90 kW] 3x380– 480 V IP20	25						No		No	
1–25 [0.75–18.5 kW] 3x380– 480 V IP54	25						Yes			
30–125 hp [22–90 kW] 3x380– 480 V IP54	25						No		No	

Table 2.11 Test Results

RFI Filter Type	Conduct emission. Maximum shielded cable length [m]						Radiated emission			
	Industrial environment				Housing, trades and light industries		Industrial environment		Housing, trades and light industries	
	EN 55011 Class A2		EN 55011 Class A1		EN 55011 Class B		EN 55011 Class A1		EN 55011 Class B	
	Without external filter	With external filter	Without external filter	With external filter	Without external filter	With external filter	Without external filter	With external filter	Without external filter	With external filter
H3 RFI filter (Class A1/B)										
20–60 hp [15–45 kW] 3x200– 240 V IP20			50		20		Yes		No	
40–125 hp [30–90 kW] 3x380– 480 V IP20			50		20		Yes		No	
1–25 [0.75–18.5 kW] 3x380– 480 V IP54			25		10		Yes			
30–125 hp [22–90 kW] 3x380– 480 V IP54			25		10		Yes		No	

Table 2.12 Test Results

2.8.3 General Aspects of Harmonics Emission

An adjustable frequency drive takes up a non-sinusoidal current from the line power, which increases the input current I_{RMS} . A non-sinusoidal current is transformed by means of a Fourier analysis and split up into sine-wave currents with different frequencies, i.e., different harmonic currents I_n with 50 Hz as the basic frequency:

	I_1	I_5	I_7
Hz	50	250	350

Table 2.13 Harmonic Currents

The harmonics do not affect the power consumption directly but increase the heat losses in the installation (transformer, cables). Consequently, in plants with a high percentage of rectifier load, maintain harmonic currents at a low level to prevent an overload of the transformer and high temperature in the cables.

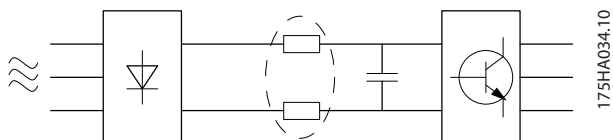

Figure 2.24 Harmonic Currents

NOTICE!

Some of the harmonic currents might disturb communication equipment connected to the same transformer or cause resonance in connection with power-factor correction batteries.

To ensure low harmonic currents, the adjustable frequency drive is equipped with intermediate circuit coils as standard. This normally reduces the input current I_{RMS} by 40%.

The voltage distortion on the line power supply voltage depends on the size of the harmonic currents multiplied by the line power impedance for the frequency in question. The total voltage distortion THD is calculated on the basis of the individual voltage harmonics using this formula:

$$THD\% = \sqrt{U_5^2 + U_7^2 + \dots + U_N^2}$$

(U_N % of U)

2.8.4 Harmonics Emission Requirements

Equipment connected to the public supply network

Options	Definition
1	IEC/EN 61000-3-2 Class A for 3-phase balanced equipment (for professional equipment only up to 1 kW total power).
2	IEC/EN 61000-3-12 Equipment 16 A-75 A and professional equipment as from 1 kW up to 16 A phase current.

Table 2.14 Connected Equipment

2.8.5 Harmonics Test Results (Emission)

Power sizes up to PK75 in T4 and P3K7 in T2 complies with IEC/EN 61000-3-2 Class A. Power sizes from P1K1 and up to P18K in T2 and up to P90K in T4 complies with IEC/EN 61000-3-12, Table 4.

	Individual Harmonic Current I_n/I_1 (%)			
	I_5	I_7	I_{11}	I_{13}
Actual 0.34–15 hp [0.25–11 kW], IP20, 200 V (typical)	32.6	16.6	8.0	6.0
Limit for $R_{sce} \geq 120$	40	25	15	10
	Harmonic current distortion factor (%)			
	THD		PWHD	
Actual 0.34–15 hp [0.25–11 kW], 200 V (typical)	39		41.4	
Limit for $R_{sce} \geq 120$	48		46	

Table 2.15 Harmonic Current 0.34–15 hp [0.25–11 kW], 200 V

	Individual Harmonic Current I_n/I_1 (%)			
	I_5	I_7	I_{11}	I_{13}
Actual 0.5–30 hp [0.37–22 kW], IP20, 380–480 V (typical)	36.7	20.8	7.6	6.4
Limit for $R_{sce} \geq 120$	40	25	15	10
	Harmonic current distortion factor (%)			
	THD		PWHD	
Actual 0.5–30 hp [0.37–22 kW], 380–480 V (typical)	44.4		40.8	
Limit for $R_{sce} \geq 120$	48		46	

Table 2.16 Harmonic Current 0.5–30 hp [0.37–22 kW], 380–480 V

	Individual Harmonic Current I_n/I_1 (%)			
	I_5	I_7	I_{11}	I_{13}
Actual 40–125 hp [30–90 kW], IP20, 380–480 V (typical)	36.7	13.8	6.9	4.2
Limit for $R_{sce} \geq 120$	40	25	15	10
	Harmonic current distortion factor (%)			
	THD		PWHD	
Actual 40–125 hp [30–90 kW] 380–480 V (typical)	40.6		28.8	
Limit for $R_{sce} \geq 120$	48		46	

Table 2.17 Harmonic Current 40–125 hp [30–90 kW], 380–480 V

	Individual Harmonic Current I_n/I_1 (%)			
	I_5	I_7	I_{11}	I_{13}
Actual 3–20 hp [2.2–15 kW], IP20, 525–600 V (typical)	48	25	7	5
Limit for $R_{sce} \geq 120$	40	25	15	10
	Harmonic current distortion factor (%)			
	THD		PWHD	
Actual 3–20 hp [2.2–15 kW], 525–600 V (typical)	55		27	

Table 2.18 Harmonic Current 3–20 hp [2.2–15 kW], 525–600 V

	Individual Harmonic Current I_n/I_1 (%)			
	I_5	I_7	I_{11}	I_{13}
Actual 25–125 hp [18.5–90 kW], IP20, 525–600 V (typical)	48.8	24.7	6.3	5
Limit for $R_{sce} \geq 120$	40	25	15	10
	Harmonic current distortion factor (%)			
	THD		PWHD	
Actual 25–125 hp [18.5–90 kW], 525–600 V (typical)	55.7		25.3	

Table 2.19 Harmonic Current 25–125 hp [18.5–90 kW], 525–600 V

	Individual Harmonic Current I_n/I_1 (%)			
	I_5	I_7	I_{11}	I_{13}
Actual 30–125 hp [22–90 kW], IP54, 400 V (typical)	36.3	14	7	4.3
Limit for $R_{sce} \geq 120$	40	25	15	10
	Harmonic current distortion factor (%)			
	THD		PWHD	
Actual 30–125 hp [22–90 kW], IP54, 400 V (typical)	40.1		27.1	
Limit for $R_{sce} \geq 120$	48		46	

Table 2.20 Harmonic Current 30–125 hp [22–90 kW], 400 V

	Individual Harmonic Current I_n/I_1 (%)			
	I_5	I_7	I_{11}	I_{13}
Actual 1–25 hp [0.75–18.5 kW], IP54, 380–480 V (typical)	36.7	20.8	7.6	6.4
Limit for $R_{sce} \geq 120$	40	25	15	10
	Harmonic current distortion factor (%)			
	THD		PWHD	
Actual 1–25 hp [0.75–18.5 kW], IP54, 380–480 V (typical)	44.4		40.8	
Limit for $R_{sce} \geq 120$	48		46	

Table 2.21 Harmonic Current 1–25 hp [0.75–18.5 kW], 380–480 V

	Individual Harmonic Current I_n/I_1 (%)			
	I_5	I_7	I_{11}	I_{13}
Actual 20–60 hp [15–45 kW], IP20, 200 V (typical)	26.7	9.7	7.7	5
Limit for $R_{sce} \geq 120$	40	25	15	10
	Harmonic current distortion factor (%)			
	THD		PWHD	
Actual 20–60 hp [15–45 kW], 200 V (typical)	30.3		27.6	
Limit for $R_{sce} \geq 120$	48		46	

Table 2.22 Harmonic Current 20–60 hp [15–45 kW], 200 V

Provided that the short-circuit power of the supply S_{sc} is greater than or equal to:

$$S_{sc} = \sqrt{3} \times R_{SCE} \times U_{line\ power} \times I_{equ} = \sqrt{3} \times 120 \times 400 \times I_{equ}$$

at the interface point between the user's supply and the public system (R_{SCE}).

It is the responsibility of the installer or user of the equipment to ensure, by consultation with the distribution network operator if necessary, that the equipment is connected only to a supply with a short-circuit power S_{sc} greater than or equal to that specified above. Other power sizes can be connected to the public supply network by consultation with the distribution network operator.

Compliance with various system level guidelines: The harmonic current data in *Table 2.15* to *Table 2.22* are given in accordance with IEC/EN 61000-3-12 with reference to the Power Drive Systems product standard. They may be used as the basis for calculation of the harmonic currents' influence on the power supply system and for the documentation of compliance with relevant regional guidelines: IEEE 519 -1992; G5/4.

2.8.6 Immunity Requirements

The immunity requirements for adjustable frequency drives depend on the environment where they are installed. The requirements for the industrial environment are higher than the requirements for the home and office environment. All Danfoss adjustable frequency drives comply with the requirements for the industrial environment and consequently comply also with the lower requirements for home and office environment with a large safety margin.

2.9 Galvanic Isolation (PELV)

2.9.1 PELV - Protective Extra Low Voltage

PELV offers protection by way of extra low voltage. Protection against electric shock is ensured when the electrical supply is of the PELV type and the installation is made as described in local/national regulations on PELV supplies.

All control terminals and relay terminals 01-03/04-06 comply with PELV (Protective Extra Low Voltage) (Does not apply to grounded Delta leg above 440 V).

Galvanic (ensured) isolation is obtained by fulfilling requirements for higher isolation and by providing the relevant creepage/clearance distances. These requirements are described in the EN 61800-5-1 standard.

The components that make up the electrical isolation, as described, also comply with the requirements for higher isolation and the relevant test as described in EN 61800-5-1.

The PELV galvanic isolation can be shown in *Figure 2.26*.

To maintain PELV all connections made to the control terminals must be PELV, e.g., thermistor must be reinforced/double insulated.

0.25–22 kW

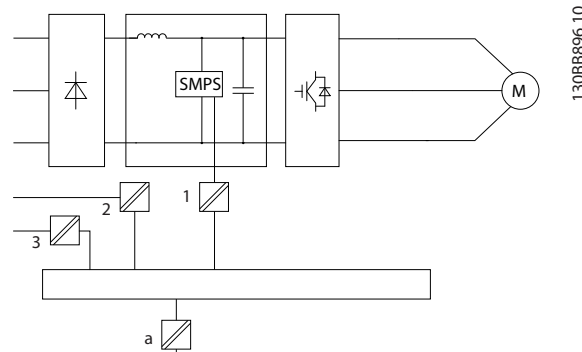

Figure 2.25 Galvanic Isolation

1	Power supply (SMPS)
2	Optocouplers, communication between AOC and BOC
3	Custom relays
a	Control card terminals

Table 2.23 Legend to *Figure 2.25*

30–90 kW

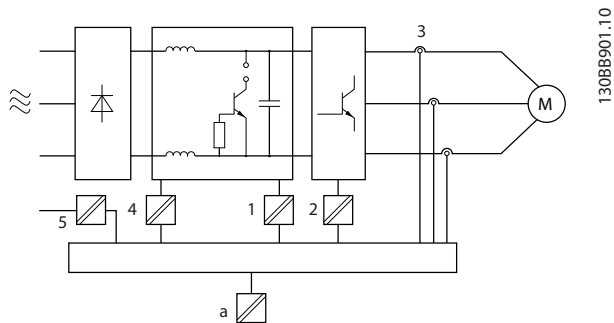

Figure 2.26 Galvanic Isolation

1	Power supply (SMPS) incl. signal isolation of UDC, indicating the intermediate current voltage
2	Gate drive that runs the IGBTs (trigger transformers/opto-couplers)
3	Current transducers
4	Internal soft-charge, RFI and temperature measurement circuits
5	Custom relays
a	Control card terminals

Table 2.24 Legend to Figure 2.26

The functional galvanic isolation (see Figure 2.25) is for the RS-485 standard bus interface.

CAUTION

Installation at high altitude:
At altitudes above 6,600 ft [2 km], contact Danfoss regarding PELV.

2.10 Ground Leakage Current

WARNING

DISCHARGE TIME

Touching the electrical parts could be fatal - even after the equipment has been disconnected from line power. Also make sure that other voltage inputs have been disconnected, such as load sharing (linkage of DC intermediate circuit), as well as the motor connection for kinetic backup. Before touching any electrical parts, wait at least the amount of time indicated in the Table 2.1. Shorter time is allowed only if indicated on the nameplate for the specific unit.

NOTICE

Leakage Current

The ground leakage current from the adjustable frequency drive exceeds 3.5 mA. To ensure that the ground cable has a good mechanical connection to the ground connection, the cable cross-section must be at least 10 mm² Cu or 16 mm² Al or two rated ground wires terminated separately.

Residual Current Device protection RCD

This product can cause a DC current in the protective conductor. Where a residual current device (RCD) is used for protection in case of direct or indirect contact, only an RCD of Type B is allowed on the supply side of this product. Otherwise, another protective measure must be applied, such as separation from the environment by double or reinforced insulation, or isolation from the supply system by a transformer. See also Application Note *Protection against Electrical Hazards, MN90G*. Protective grounding of the adjustable frequency drive and the use of RCDs must always follow national and local regulations.

2.11 Extreme Running Conditions

Short circuit (motor phase – phase)

Current measurement in each of the three motor phases or in the DC link, protects the adjustable frequency drive against short circuits. A short circuit between two output phases causes an overcurrent in the inverter. The inverter is turned off individually when the short circuit current exceeds the permitted value (Alarm 16 Trip Lock). To protect the adjustable frequency drive against a short circuit at the load sharing and brake outputs see the design guidelines.

Switching on the output

Switching on the output between the motor and the adjustable frequency drive is fully permitted. The adjustable frequency drive is not damaged in any way by switching on the output. However, fault messages may appear.

Motor-generated overvoltage

The voltage in the intermediate circuit is increased when the motor acts as a generator. This occurs in following cases:

1. The load drives the motor (at constant output frequency from the adjustable frequency drive), that is the load generates energy.

2. During deceleration ("ramp-down") if the moment of inertia is high, the friction is low and the ramp-down time is too short for the energy to be dissipated as a loss in the adjustable frequency drive, the motor and the installation.
3. Incorrect slip compensation setting (1-62 Slip Compensation) may cause higher DC link voltage.

The control unit may attempt to correct the ramp if possible (2-17 Over-voltage Control.)
 The inverter turns off to protect the transistors and the intermediate circuit capacitors when a certain voltage level is reached.

Line drop-out

During a line drop-out, the adjustable frequency drive keeps running until the intermediate circuit voltage drops below the minimum stop level, which is typically 15% below the adjustable frequency drive's lowest rated supply voltage. The AC line voltage before the drop-out and the motor load determine how long it takes for the inverter to coast.

2.11.1 Motor Thermal Protection

This is the way Danfoss protects the motor from being overheated. It is an electronic feature that simulates a bimetal relay based on internal measurements. The characteristic is shown in Figure 2.27.

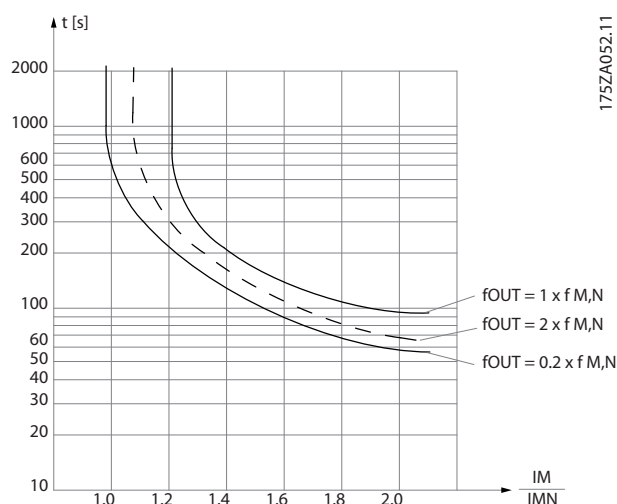

Figure 2.27 Motor Thermal Protection Characteristic

The X-axis show the ratio between I_{motor} and $I_{motor\ nominal}$. The Y-axis is showing the time in seconds before the ETR cuts off and trips the adjustable frequency drive. The curves are showing the characteristic nominal speed at twice the nominal speed and at 0.2x the nominal speed.

It is clear that at lower speed the ETR cuts off at lower heat due to less cooling of the motor. In that way, the motors are protected from being overheated even at low speeds. The ETR feature calculates the motor temperature based on the actual current and speed.

The thermistor cut-out value is $>3\ k\Omega$.

Integrate a thermistor (PTC sensor) in the motor for winding protection.

Motor protection can be implemented using a range of techniques: PTC sensor in motor windings; mechanical thermal switch (Klixon type); or Electronic Thermal Relay (ETR).

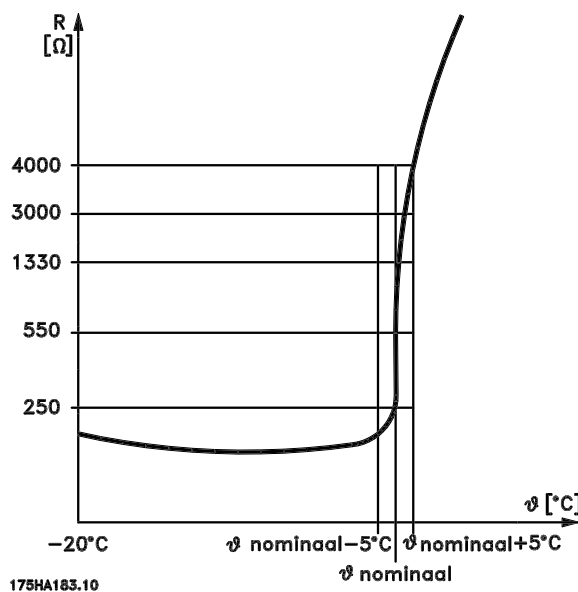

Figure 2.28 Trip due to High Motor Temperature

Using a digital input and 10 V as power supply:
 Example: The adjustable frequency drive trips when the motor temperature is too high.

Parameter set-up:

Set 1-90 Motor Thermal Protection to [2] Thermistor Trip

Set 1-93 Thermistor Source to [6] Digital Input 29

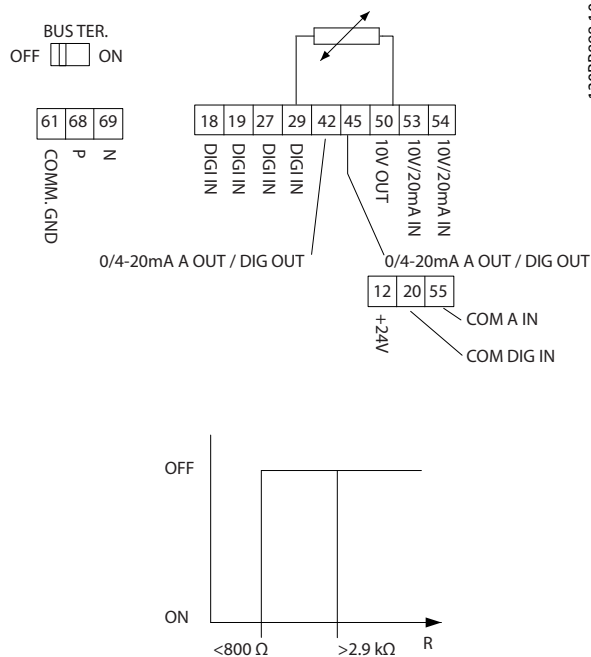

Figure 2.29 Digital Input/10 V Power Supply

Using an analog input and 10 V as power supply:
 Example: The adjustable frequency drive trips when the motor temperature is too high.

Parameter set-up:

Set 1-90 Motor Thermal Protection to [2] Thermistor Trip

Set 1-93 Thermistor Source to [2] Analog Input 54

NOTICE!

Do not set Analog Input 54 as reference source.

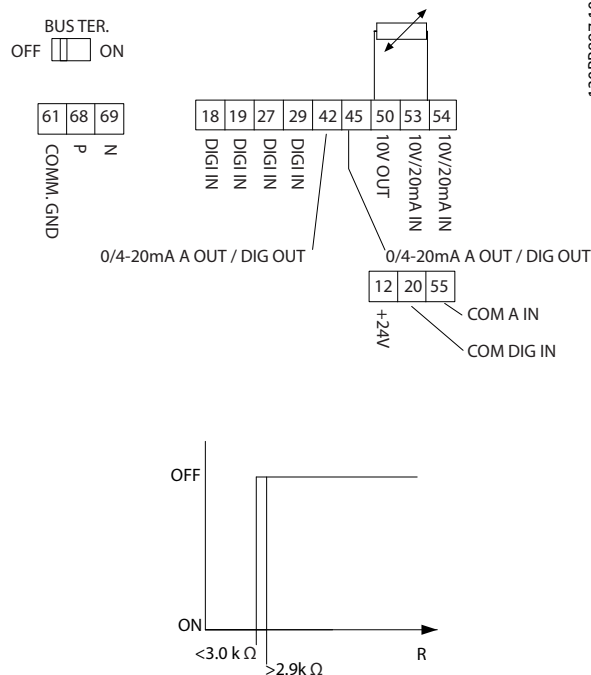

Figure 2.30 Analog Input/10 V Power Supply

Input	Supply Voltage [V]	Threshold Cut-out Values [Ω]
Digital	10	<math>< 800 \Rightarrow 2.9 k</math>
Analog	10	<math>< 800 \Rightarrow 2.9 k</math>

Table 2.25 Supply Voltage

NOTICE!

Check that the selected supply voltage follows the specification of the used thermistor element.

Summary

With the ETR, the motor is protected for being overheated and there is no need for any further motor protection. That means when the motor is heated up, the ETR timer controls for how long time the motor can run at the high temperature before it is stopped to prevent over heating. If the motor is overloaded without reaching the temperature, the ETR shuts of the motor.

ETR is activated in 1-90 Motor Thermal Protection.

3 Selection

3.1 Options and Accessories

3.1.1 Local Control Panel (LCP)

Ordering no.	Description
132B0200	LCP for all IP20 units

Table 3.1 Ordering Number

Enclosure	IP55 front
Max. cable length to unit	10 ft [3 m]
Communication std.	RS-485

Table 3.2 Technical Data

3.1.2 Mounting of LCP in Panel Front

Step 1

Fit gasket on LCP.

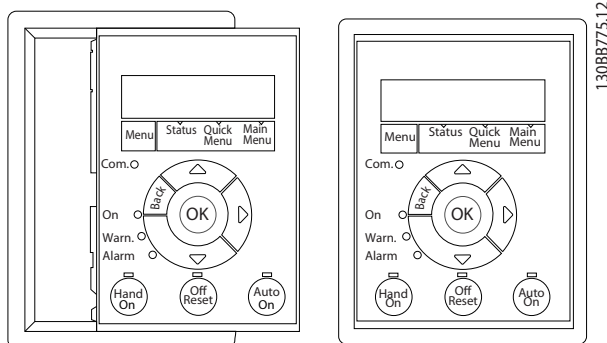

Figure 3.1 Fit Gasket

Step 2

Place LCP on panel, see dimensions of hole on Figure 3.2.

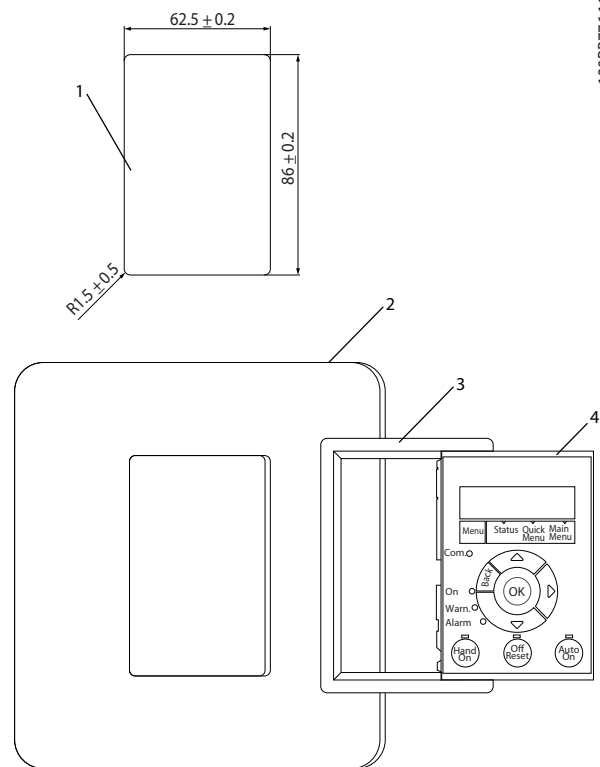

Figure 3.2 Place LCP on Panel

3

Step 3

Place bracket on back of the LCP, then slide down. Tighten screws and connect cable female side to LCP.

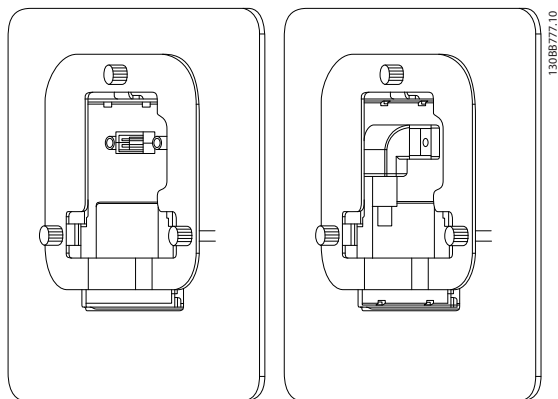

Figure 3.3 Place Bracket on LCP

Step 4

Connect cable to adjustable frequency drive.

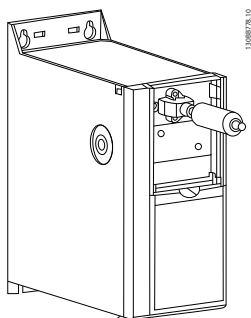

Figure 3.4 Connect Cable

NOTICE!

Use the provided thread cutting screws to fasten connector to the adjustable frequency drive, tightening torque 11.51 in-lb [1.3 Nm].

3.1.3 IP21/TYPE 1 Enclosure Kit

IP21/TYPE 1 is an optional enclosure element available for IP20 units.

If the enclosure kit is used, an IP20 unit is upgraded to comply with enclosure IP21/TYPE 1.

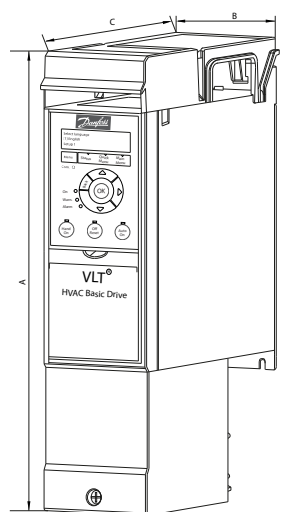

Figure 3.5 H1-H5

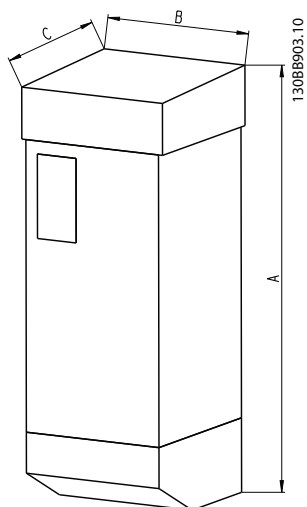

Figure 3.6 Dimensions

Frame	IP class	Power			Height (in [mm]) A	Width (in [mm]) B	Depth (in [mm]) C	IP21 kit ordering no.	Type 1 kit ordering no.
		3 x 200–240 V	3 x 380–480 V	3 x 525–600 V					
H1	IP20	0.34–2 hp [0.25–1.5 kW]	0.5–2 hp [0.37–1.5 kW]		11.54 [293]	3.19 [81]	6.81 [173]	132B0212	132B0222
H2	IP20	3 hp [2.2 kW]	3–5 hp [2.2–4 kW]		12.68 [322]	3.78 [96]	7.68 [195]	132B0213	132B0223
H3	IP20	4 hp [3.7 kW]	7.5–10 hp [5.5–7.5 kW]		13.62 [346]	4.17 [106]	8.27 [210]	132B0214	132B0224
H4	IP20	7.5–10 hp [5.5–7.5 kW]	15–20 hp [11–15 kW]		14.72 [374]	5.55 [141]	9.65 [245]	132B0215	132B0225
H5	IP20	15 hp [11 kW]	25–30 hp [18.5–22 kW]		16.46 [418]	6.34 [161]	10.24 [260]	132B0216	132B0226
H6	IP20	20–25 hp [15–18.5 kW]	40–60 hp [30–45 kW]	25–40 hp [18.5–30 kW]	26.1 [663]	10.24 [260]	9.53 [242]	132B0217	132B0217
H7	IP20	30–40 hp [22–30 kW]	75–100 hp [55–75 kW]	50–75 hp [37–55 kW]	31.77 [807]	12.95 [329]	13.19 [335]	132B0218	132B0218
H8	IP20	50–60 hp [37–45 kW]	125 hp [90 kW]	100–125 hp [75–90 kW]	37.13 [943]	15.35 [390]	13.19 [335]	132B0219	132B0219
H9	IP20			3–10 hp [2.2–7.5 kW]	14.65 [372]	5.12 [130]	8.07 [205]	132B0220	132B0220
H10	IP20			15–20 hp [11–15 kW]	18.7 [475]	6.5 [165]	9.8 [249]	132B0221	132B0221

Table 3.3 Enclosure Kit Specifications

3.1.4 Decoupling Plate

Use the decoupling plate for EMC correct installation.

Shown here on an H3 enclosure.

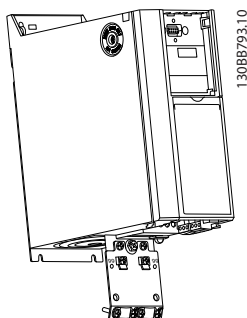

Figure 3.7 Decoupling Plate

Frame	IP class	Power (hp [kW])			Decoupling plate
		3 x 200–240 V	3 x 380–480 V	3 x 525–600 V	
H1	IP20	0.34–2 [0.25–1.5]	0.5–2 [0.37–1.5]		132B0202
H2	IP20	3 [2.2]	3–5 [2.2–4]		132B0202
H3	IP20	5 [3.7]	7.5–10 [5.5–7.5]		132B0204
H4	IP20	7.5–10 [5.5–7.5]	15–20 [11–15]		132B0205
H5	IP20	15 [11]	25–30 [18.5–22]		130B0205
H6	IP20	20–25 [15–18.5]	40 [30]	25–40 [18.5–30]	132B0207
H6	IP20		50–60 [37–45]		132B0242
H7	IP20	30–40 [22–30]	75 [55]	50–75 [37–55]	132B0208
H7	IP20		100 [75]		132B0243
H8	IP20	50–60 [37–45]	125 [90]	100–125 [75–90]	132B0209

Table 3.4 Decoupling Plate Specifications

NOTICE!

For H9 and H10 adjustable frequency drives, the decoupling plates are included in the accessory bag.

4 How to Order

4.1 Configuration

4.1.1 Drive Configurator

It is possible to design an adjustable frequency drive according to the application requirements by using the ordering number system.

Adjustable frequency drives can be ordered as standard or with internal options by using a type code string, e.g.,

FC-101PK25T2E20H4XXCXXSXXXXAXBXXXXDX

Use the Internet-based Drive Configurator to configure the right adjustable frequency drive for the right application and generate the type code string. The Drive Configurator automatically generates an 8-digit sales number to be delivered to your local sales office.

Furthermore, a project list with several products can be established and sent to Danfoss sales representative.

4.1.2 Type Code String

1 2 3 4 5 6 7 8 9 10 11 12 13 14 15 16 17 18 19 20 21 22 23 24 25 26 27 28 29 30 31 32 33 34 35 36 37 38 39
 F C - 1 0 1 P T H X X X S X X X A X B X C X X X X D X

13088899.10

Figure 4.1 Type Code

4

Description	Pos.	Possible choice
Product group & FC series	1–6	FC 101
Power rating	7–10	0.25–90 kW (PK25–P90K)
Number of phases	11	Three phases (T)
AC line voltage	11–12	T2: 200–240 V AC T4: 380–480 V AC T6: 525–600 V AC
Enclosure	13–15	E20: IP20/Chassis P20: IP20/Chassis with backplate E5A: IP54 P5A: IP54 with backplate
RFI filter	16–17	H1: RFI filter class A1/B H2: RFI filter class A2 H3: RFI filter class A1/B (reduced cable length) H4: RFI filter class A1
Brake	18	X: No brake chopper included
Display	19	A: Alpha Numeric Local Control Panel X: No Local Control Panel
Coating PCB	20	X: No coated PCB C: Coated PCB
Line power option	21	X: No line power option
Adaption	22	X: No adaption
Adaption	23	X: No adaption
Software release	24–27	SXXXX: Latest release - standard software
Software language	28	X: Standard
A options	29–30	AX: No A options
B options	31–32	BX: No B options
C0 options MCO	33–34	CX: No C options
C1 options	35	X: No C1 options
C option software	36–37	XX: No options
D options	38–39	DX: No D0 options

Table 4.1 Type Code Descriptions

4.2 Ordering Numbers

4.2.1 Ordering Numbers: Options and Accessories

	Enclosure frame size AC line voltage	H1	H2	H3	H4	H5	H6 [kW/Hp]		H7 [kW/Hp]		H8
		[kW/Hp]	[kW/Hp]	[kW/Hp]	[kW/Hp]	[kW/Hp]					[kW/Hp]
	T2 (200– 240 V AC)	0.25–1.5/ 0.33–2	2.2/3	3.7/5	5.5–7.5/ 7.5–10	11/15	15–18.5/ 20		22–30/ 30		37–45/ 50–60
	T4 (380– 480 V AC)	0.37–1.5/ 0.5–2	2.2–4/ 3–5.4	5.5–7.5/ 7.5–10	11–15/ 15–20	18.5–22/ 25–30	30/40	37–45/ 50–60	55/75	75/100	90/125
	T6 (525– 600 V AC)						18.5–30/ 30		37–55/ 60		75–90/ 120–125
Description											
LCP		132B0200									
LCP panel mounting kit IP55 incl. 10 ft [3 m] cable		132B0201									
Decoupling plate		132B0202	132B0202	132B0204	132B0205	132B0205	132B0207	132B0242	132B0208	132B0243	132B0209
IP21 option		132B0212	132B0213	132B0214	132B0215	132B0216	132B0217		132B0218		132B0219
Nema Type 1 Kit		132B0222	132B0223	132B0224	132B0225	132B0226	132B0217		132B0218		132B0219

Table 4.2 Options and Accessories

4.2.2 Harmonic Filters

4

3x380–480 V 50 Hz					
Power [kW]	Drive input current Continuous [A]	Default switching frequency [kHz]	THID level [%]	Order number filter IP00	Code number filter IP20
22	41.5	4	4	130B1397	130B1239
30	57	4	3	130B1398	130B1240
37	70	4	3	130B1442	130B1247
45	84	3	3	130B1442	130B1247
55	103	3	5	130B1444	130B1249
75	140	3	4	130B1445	130B1250
90	176	3	4	130B1445	130B1250

Table 4.3 AHF Filters (5% current distortion)

3x380–480 V 50 Hz					
Power [kW]	Drive input current Continuous [A]	Default switching frequency [kHz]	THID level [%]	Order number filter IP00	Code number filter IP20
22	41.5	4	6	130B1274	130B1111
30	57	4	6	130B1275	130B1176
37	70	4	9	130B1291	130B1201
45	84	3	9	130B1291	130B1201
55	103	3	9	130B1292	130B1204
75	140	3	8	130B1294	130B1213
90	176	3	8	130B1294	130B1213

Table 4.4 AHF Filters (10% current distortion)

3x440–480 V 60 Hz					
Power [kW]	Drive input current Continuous [A]	Default switching frequency [kHz]	THID level [%]	Order number filter IP00	Code number filter IP20
22	34.6	4	3	130B1792	130B1757
30	49	4	3	130B1793	130B1758
37	61	4	3	130B1794	130B1759
45	73	3	4	130B1795	130B1760
55	89	3	4	130B1796	130B1761
75	121	3	5	130B1797	130B1762
90	143	3	5	130B1798	130B1763

Table 4.5 AHF Filters (5% current distortion)

3x440–480 V 60 Hz					
Power [kW]	Drive input current Continuous [A]	Default switching frequency [kHz]	THID level [%]	Order number filter IP00	Code number filter IP20
22	34.6	4	6	130B1775	130B1487
30	49	4	8	130B1776	130B1488
37	61	4	7	130B1777	130B1491
45	73	3	9	130B1778	130B1492
55	89	3	8	130B1779	130B1493
75	121	3	9	130B1780	130B1494
90	143	3	10	130B1781	130B1495

Table 4.6 AHF Filters (10% current distortion)

4.2.3 External RFI Filter

External filters to fulfill A1 50 m/B1 20 m.

Power (hp [kW]) Size 380-480 V	Type	A	B	C	D	E	F	G	H	I	J	K	L1	Torque [Nm]	Weight [kg]	Ordering Number
0.5-3 [0.37-2.2]	FN3258-7-45	190	40	70	160	180	20	4.5	1	10.6	M5	20	31	0.7-0.8	0.5	132B0244
4-10 [3-7.5]	FN3258-16-45	250	45	70	220	235	25	4.5	1	10.6	M5	22.5	31	0.7-0.8	0.8	132B0245
15-20 [11-15]	FN3258-30-47	270	50	85	240	255	30	5.4	1	10.6	M5	25	40	1.9-2.2	1.2	132B0246
25-30 [18.5-22]	FN3258-42-47	310	50	85	280	295	30	5.4	1	10.6	M5	25	40	1.9-2.2	1.4	132B0247

Table 4.7 RFI Filters - Details

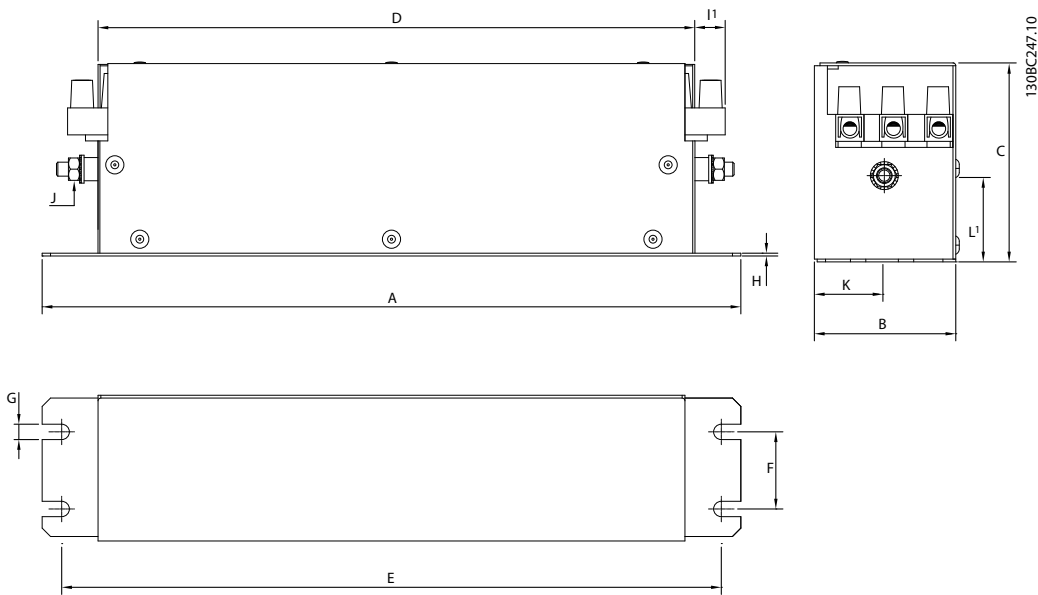
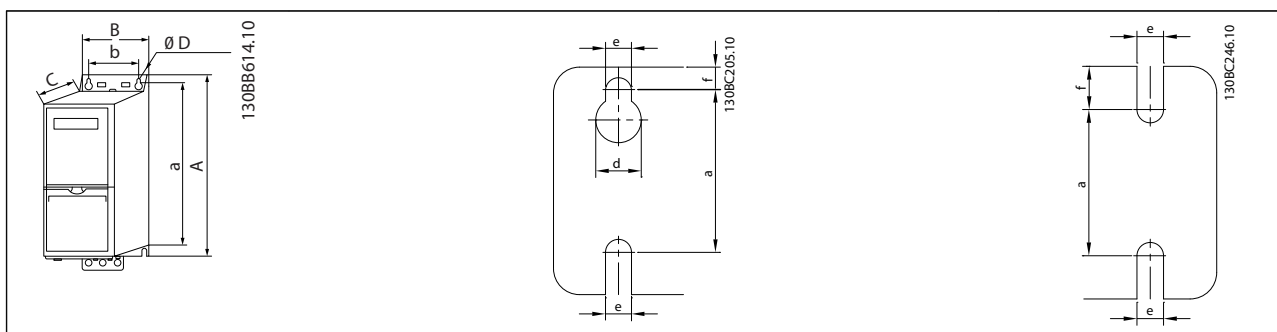

Figure 4.2 RFI Filter

5 How to Install

5.1 Mechanical Dimensions

5.1.1 Adjustable Frequency Drive Dimensions



Enclosure		Power (hp [kW])			Height (in [mm])			Width (in [mm])		Depth (in [mm])	Mounting hole (in [mm])			Max. Weight
Frame	IP Class	3x 200–240 V	3x 380–480 V	3x 525–600 V	A	A ¹	a	B	b	C	d	e	f	lb [kg]
H1	IP20	0.34–2 [0.25–1.5]	0.5–2 [0.37–1.5]		7.68 [195]	10.75 [273]	7.21 [183]	2.95 [75]	2.21 [56]	6.61 [168]	0.35 [9]	0.18 [4.5]	0.21 [5.3]	4.63 [2.1]
H2	IP20	3 [2.2]	3–5 [2.2–4.0]		8.94 [227]	11.93 [303]	8.35 [212]	3.54 [90]	2.56 [65]	7.48 [190]	0.43 [11]	0.22 [5.5]	0.29 [7.4]	7.5 [3.4]
H3	IP20	5 [3.7]	7.5–10 [5.5–7.5]		8.86 [255]	12.95 [329]	9.45 [240]	3.94 [100]	2.91 [74]	8.11 [206]	0.43 [11]	0.22 [5.5]	0.32 [8.1]	9.92 [4.5]
H4	IP20	7.5–10 [5.5–7.5]	15–20 [11–15]		11.65 [296]	14.13 [359]	10.83 [275]	5.32 [135]	4.13 [105]	9.49 [241]	0.5 [12.6]	0.28 [7]	0.33 [8.4]	17.42 [7.9]
H5	IP20	15 [11]	25–30 [18.5–22]		13.15 [334]	15.83 [402]	12.36 [314]	5.91 [150]	4.72 [120]	8.86 [255]	0.5 [12.6]	0.28 [7]	0.34 [8.5]	20.94 [9.5]
H6	IP20	20–25 [15–18.5]	40–60 [30–45]	25–40 [18.5–30]	20.4 [518]	23.43/ 25 [595/ 635] (60 hp [45 kW])	19.50 [495]	9.41 [239]	7.87 [200]	9.53 [242]	-	0.34 [8.5]	0.60 [15]	54.01 [24.5]
H7	IP20	30–40 [22–30]	75–100 [55–75]	50–75 [37–55]	21.65 [550]	24.8/ 27.17 [630/ 690] (100 hp [75 kW])	20.51 [521]	12.32 [313]	10.63 [270]	13.19 [335]	-	0.34 [8.5]	0.68 [17]	79.37 [36]
H8	IP20	50–60 [37–45]	125 [90]	100–125 [75–90]	25.98 [660]	31.5 [800]	24.84 [631]	14.76 [375]	12.99 [330]	13.19 [335]	-	0.34 [8.5]	0.68 [17]	112.44 [51]
H9	IP20			3–10 [2.2–7.5]	10.59 [269]	14.72 [374]	10.12 [257]	5.12 [130]	4.33 [110]	8.07 [205]	15 [11]	0.22 [5.5]	0.35 [9]	14.6 [6.6]
H10	IP20			15–20 [11–15]	15.71 [399]	16.5 [419]	14.96 [380]	6.5 [165]	5.51 [140]	9.76 [248]	0.47 [12]	0.28 [6.8]	0.3 [7.5]	26.46 [12]

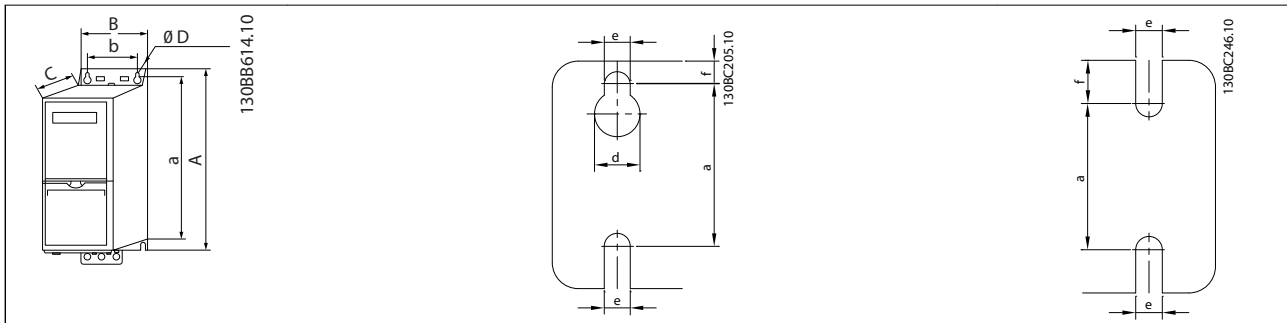

Enclosure		Power (hp [kW])			Height (in [mm])			Width (in [mm])		Depth (in [mm])	Mounting hole (in [mm])			Max. Weight
Frame	IP Class	3x 200–240 V	3x 380–480 V	3x 525–600 V	A	A ¹	a	B	b	C	d	e	f	lb [kg]
I2	IP54		1–5 [0.75–4.0]		13.07 [332]	-	12.54 [318.5]	4.53 [115]	2.91 [74]	8.86 [225]	0.43 [11]	0.22 [5.5]	0.35 [9]	11.69 [5.3]
I3	IP54		7.5–10 [5.5–7.5]		14.49 [368]	-	13.94 [354]	5.32 [135]	3.50 [89]	9.33 [237]	0.47 [12]	0.26 [6.5]	0.37 [9.5]	15.87 [7.2]
I4	IP54		15–25 [11–18.5]		18.74 [476]	-	18.11 [460]	7.1 [180]	5.24 [133]	11.42 [290]	0.47 [12]	0.26 [6.5]	0.37 [9.5]	30.42 [13.8]
I6	IP54		30–50 [22–37]		25.59 [650]	-	24.57 [624]	9.53 [242]	8.27 [210]	10.24 [260]	0.75 [19]	0.35 [9]	0.35 [9]	59.53 [27]
I7	IP54		60–75 [45–55]		26.77 [680]	-	25.51 [648]	12.13 [308]	10.71 [272]	12.21 [310]	0.75 [19]	0.35 [9]	0.39 [9.8]	99.21 [45]
I8	IP54		100–125 [75–90]		30.32 [770]	-	29.1 [739]	15.57 [370]	13.15 [334]	13.19 [335]	19	9	0.39 [9.8]	2.56 [65]

Table 5.1 Dimensions

¹ Including decoupling plate

The dimensions are only for the physical units, but when installing in an application it is necessary to add space for free air passage both above and below the units. The amount of space for free air passage is listed in *Table 5.2*:

Enclosure		Clearance [mm]	
Frame	IP class	Above unit	Below unit
H1	20	100	100
H2	20	100	100
H3	20	100	100
H4	20	100	100
H5	20	100	100
H6	20	200	200
H7	20	200	200
H8	20	225	225
H9	20	100	100
H10	20	200	200
I2	54	100	100
I3	54	100	100
I4	54	100	100
I6	54	200	200
I7	54	200	200
I8	54	225	225

Table 5.2 Clearance Needed for Free Air Passage

5.1.2 Shipping Dimensions

Enclosure frame size	H1	H2	H3	H4	H5	H6	H7	H8	H9	H10	I2	I3	I4	I5	I6	I7	I8	
AC line voltage																		
T2 (200–240 V AC) [kW/HP]	0.25–1.5/ 0.33–2	2.2/3	3.7/5	5.5–7.5/ 7.5–10	11/15	15–18.5/ 20	22–30/ 30–40	37–45/ 50–60										
T4 (380–480 V AC) [kW/HP]	0.37–1.5/ 0.5–2	2.2–4/ 3–5.4	5.5–7.5/ 7.5–10	11–15/ 15–20	18.5–22/ 25–30	30–45/ 40–60	55–75/ 73–100	90/ 125			0.75/ 1.0–5.0	5.5–7.5/ 7.5–10	11–18.5/ 15–25	11–18.5/ 15–25	22–37/ 30–50	45–55/ 60–70	75–90/ 125	
T6 (525–600 V AC) [kW/HP]						18.5–30/ 30–40	37–55/ 60–70	75–90/ 100–125	2.2–7.5/ 3.0–10	11–15/ 15–20								
IP frame	IP20																	
Maximum weight [kg]	2.1	3.4	4.5	7.9	9.5	24.5	36	51	6.6	11.5	6.1	7.8	13.8	23.3	28.3	41.5	60.5	
Shipping dimensions	IP54																	
Height [mm/inch]	255/10.0	300/ 11.8	330/ 13.0	380/ 15.0	420 / 16.5	850	850	850	380	500	440	470	588	850	850	850	950	
Width [mm/inch]	154/6.1	170/ 6.7	188/ 7.4	250/ 9.8	290/ 11.4	370	410	490	290	330	200	240	285	370	370	410	490	
Depth [mm/inch]	235/9.3	260/ 10.2	282/ 11.1	375/ 14.8	375/ 14.8	460	540	490	200	350	300	330	385	460	460	540	490	

Table 5.3 Dimensions

5.1.3 Field Mounting

IP21/TYPE 1 kits are recommended.

5.2 Electrical Data

5

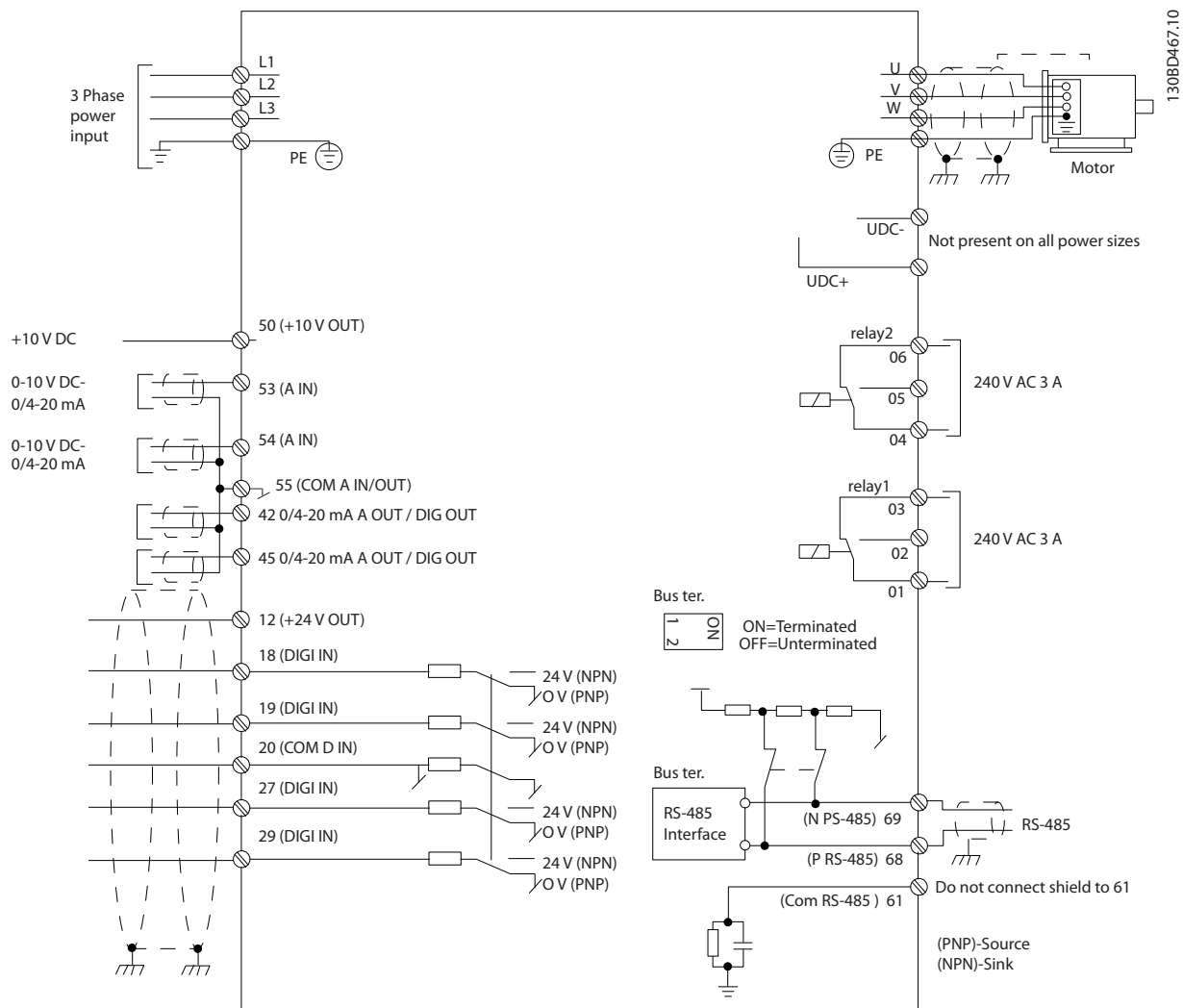

Figure 5.1 Basic Wiring Schematic Drawing

NOTICE!

There is no access to UDC- and UDC+ on the following units:

IP20 380–480 V 40–125 hp [30–90 kW]

IP20 200–240 V 20–60 hp [15–45 kW]

IP20 525–600 V 3–125 hp [2.2–90 kW]

IP54 380–480 V 30–125 hp [22–90 kW]

5.2.1 Electrical Installation in General

All cabling must comply with national and local regulations on cable cross-sections and ambient temperature. Copper conductors required, (167 °F [75 °C]) recommended.

Frame	IP class	Power (hp [kW])		Torque (in-lb [Nm])					
		3x200–240 V	3x380–480 V	Line	Motor	DC connection	Control terminals	Ground	Relay
H1	IP20	0.34–2 [0.25–1.5]	0.5–2 [0.37–1.5]	12.39 [1.4]	7.08 [0.8]	7.08 [0.8]	4.43 [0.5]	7.08 [0.8]	4.43 [0.5]
H2	IP20	3 [2.2]	3–5 [2.2–4]	12.39 [1.4]	7.08 [0.8]	7.08 [0.8]	4.43 [0.5]	7.08 [0.8]	4.43 [0.5]
H3	IP20	5 [3.7]	7.5–10 [5.5–7.5]	12.39 [1.4]	7.08 [0.8]	7.08 [0.8]	4.43 [0.5]	7.08 [0.8]	4.43 [0.5]
H4	IP20	7.5–10 [5.5–7.5]	15–20 [11–15]	12.39 [1.2]	12.39 [1.2]	12.39 [1.2]	4.43 [0.5]	7.08 [0.8]	4.43 [0.5]
H5	IP20	15 [11]	25–30 [18.5–22]	12.39 [1.2]	12.39 [1.2]	12.39 [1.2]	4.43 [0.5]	7.08 [0.8]	4.43 [0.5]
H6	IP20	11–25 [15–18]	40–60 [30–45]	0.18 [4.5]	0.18 [4.5]	-	4.43 [0.5]	26.55 [3]	4.43 [0.5]
H7	IP20	30–40 [22–30]	75 [55]	88.51 [10]	88.51 [10]	-	4.43 [0.5]	26.55 [3]	4.43 [0.5]
H7	IP20	-	2.95 [75]	123.91 [14]	123.91 [14]	-	4.43 [0.5]	26.55 [3]	4.43 [0.5]
H8	IP20	50–60 [37–45]	125 [90]	212.42 [24] ²	212.42 [24] ²	-	4.43 [0.5]	26.55 [3]	4.43 [0.5]

Table 5.4 Enclosure H1-H8

Frame	IP class	Power (hp [kW])		Torque (in-lb [Nm])					
		3x380–480 V	Line	Motor	DC connection	Control terminals	Ground	Relay	
I2	IP54	1– 5 [0.75–4.0]	12.39 [1.4]	7.08 [0.8]	7.08 [0.8]	4.43 [0.5]	7.08 [0.8]	4.43 [0.5]	
I3	IP54	7.5–10 [5.5–7.5]	12.39 [1.4]	7.08 [0.8]	7.08 [0.8]	4.43 [0.5]	7.08 [0.8]	4.43 [0.5]	
I4	IP54	15–25 [11–18.5]	12.39 [1.4]	7.08 [0.8]	7.08 [0.8]	4.43 [0.5]	7.08 [0.8]	4.43 [0.5]	
I6	IP54	30–50 [22–37]	0.18 [4.5]	0.18 [4.5]	-	4.43 [0.5]	26.55 [3]	5.31 [0.6]	
I7	IP54	60–75 [45–55]	88.51 [10]	88.51 [10]	-	4.43 [0.5]	26.55 [3]	5.31 [0.6]	
I8	IP54	100–125 [75–90]	123.91/212.42 [14/24] ¹	123.91/212.42 [14/24] ¹	-	4.43 [0.5]	26.55 [3]	5.31 [0.6]	

Table 5.5 Enclosure I1-I8

Frame	IP class	Power (hp [kW])		Torque (in-lb [Nm])					
		3x525–600 V	Line	Motor	DC connection	Control terminals	Ground	Relay	
H9	IP20	3–10 [2.2–7.5]	15.93 [1.8]	15.93 [1.8]	Not recommended	4.43 [0.5]	26.55 [3]	5.31 [0.6]	
H10	IP20	15–20 [11–15]	15.93 [1.8]	15.93 [1.8]	Not recommended	4.43 [0.5]	26.55 [3]	5.31 [0.6]	
H6	IP20	25–40 [18.5–30]	0.18 [4.5]	0.18 [4.5]	-	4.43 [0.5]	26.55 [3]	4.43 [0.5]	
H7	IP20	50–75 [37–55]	88.51 [10]	88.51 [10]	-	4.43 [0.5]	26.55 [3]	4.43 [0.5]	
H8	IP20	100–125 [75–90]	123.91/212.42 [14/24] ¹	123.91/212.42 [14/24] ¹	-	4.43 [0.5]	26.55 [3]	4.43 [0.5]	

Table 5.6 Details of Tightening Torques

¹ Cable dimensions $\leq 0.1472 \text{ in}^2$ [95 mm²]

² Cable dimensions $> 0.1472 \text{ in}^2$ [95 mm²]

5.2.2 Connecting to Line Power and Motor

The adjustable frequency drive is designed to operate all standard 3-phased asynchronous motors. For maximum cross-section on wires, see *chapter 8.2 General Specifications*.

- Use a shielded/armored motor cable to comply with EMC emission specifications, and connect this cable to both the decoupling plate and the motor metal.
- Keep motor cable as short as possible to reduce the noise level and leakage currents.
- For further details on mounting of the decoupling plate, see *FC 101 Decoupling Plate Mounting Instruction*.
- Also see *EMC-compatible Installation in the VLT® HVAC Basic Design Guide*.

1. Mount the ground wires to the ground terminal.
2. Connect the motor to terminals U, V and W.
3. Mount line power supply to terminals L1, L2 and L3 and tighten.

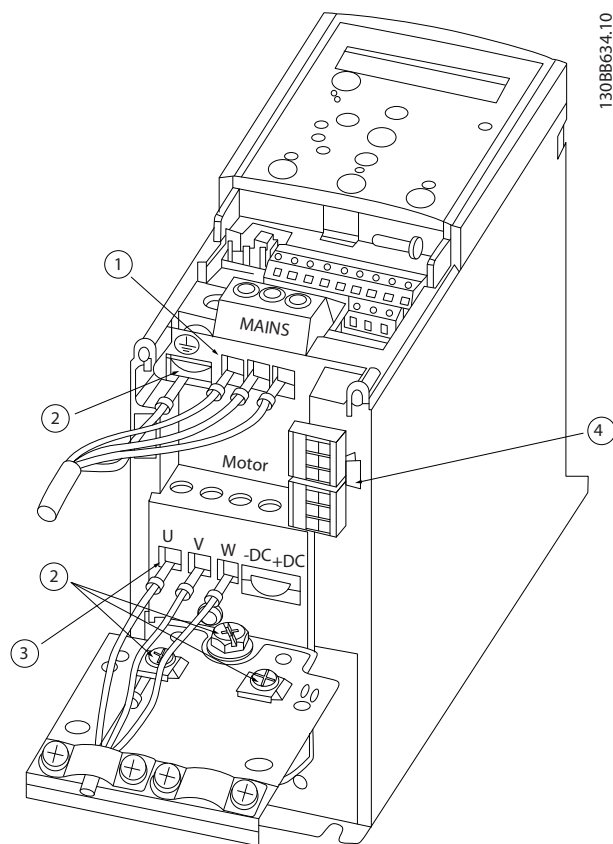

Figure 5.2 H1-H5 Frame
 IP20 200–240 V 0.34–15 hp [0.25–11 kW] and IP20 380–480 V
 0.5–30 hp [0.37–22 kW].

1	Line
2	Ground
3	Motor
4	Relays

Table 5.7 Legend to Figure 5.2

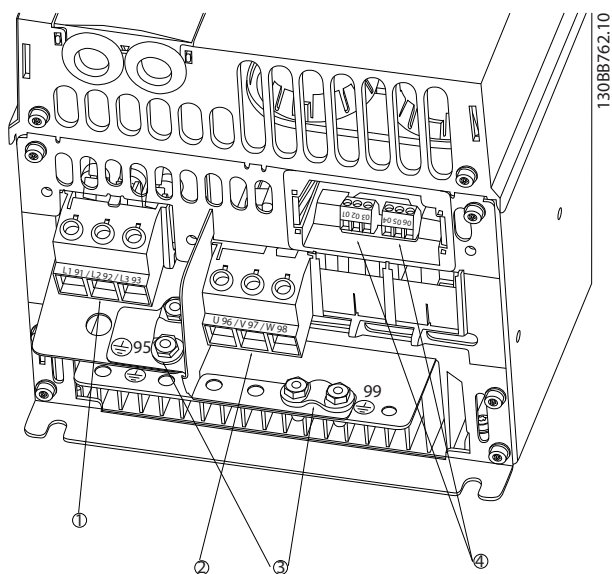

Figure 5.3 H6 Frame

IP20 380–480 V 40–60 hp [30–45 kW]
 IP20 200–240 V 20–25 hp [15–18.5 kW]
 IP20 525–600 V 30–40 hp [22–30 kW]

1	Line
2	Motor
3	Ground
4	Relays

Table 5.8 Legend to Figure 5.3

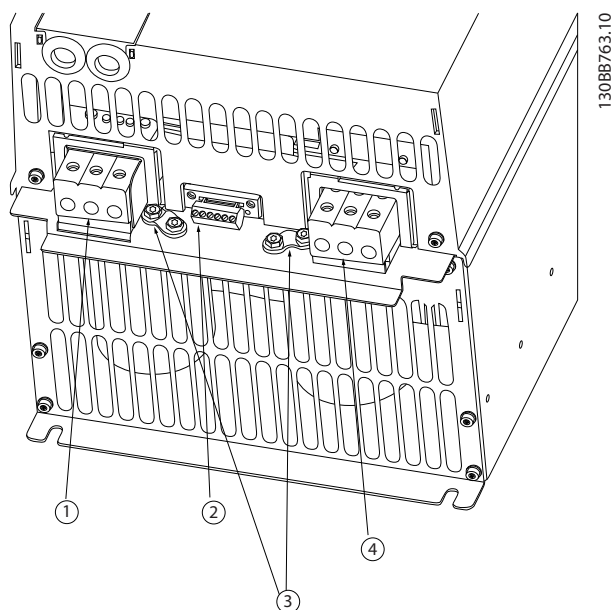

Figure 5.4 H7 Frame

IP20 380–480 V 75–100 hp [55–75 kW]
 IP20 200–240 V 30–40 hp [22–30 kW]
 IP20 525–600 V 60–75 hp [45–55 kW]

1	Line
2	Relays
3	Ground
4	Motor

Table 5.9 Legend to Figure 5.4

5

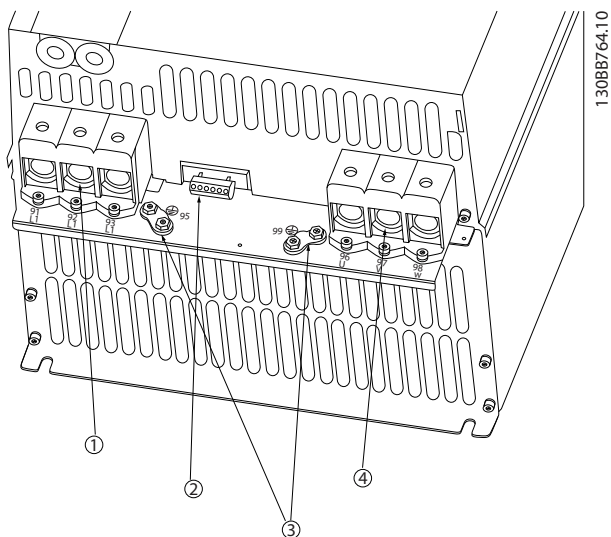

Figure 5.5 H8 Frame
 IP20 380-480 V 125 hp [90 kW]
 IP20 200-240 V 50-60 hp [37-45 kW]
 IP20 525-600 V 100-125 hp [75-90 kW]

1	Line
2	Relays
3	Ground
4	Motor

Table 5.10 Legend to

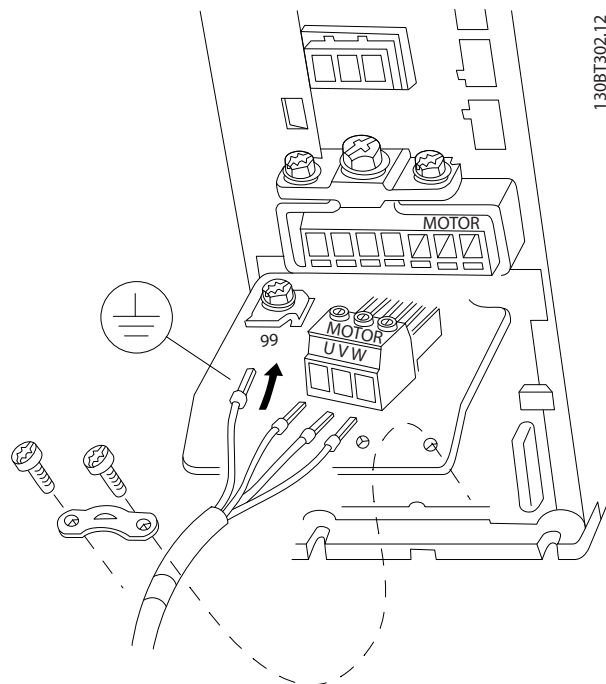

Figure 5.6 H9 Frame
 IP20 600 V 3-10 hp [2.2-7.5 kW]

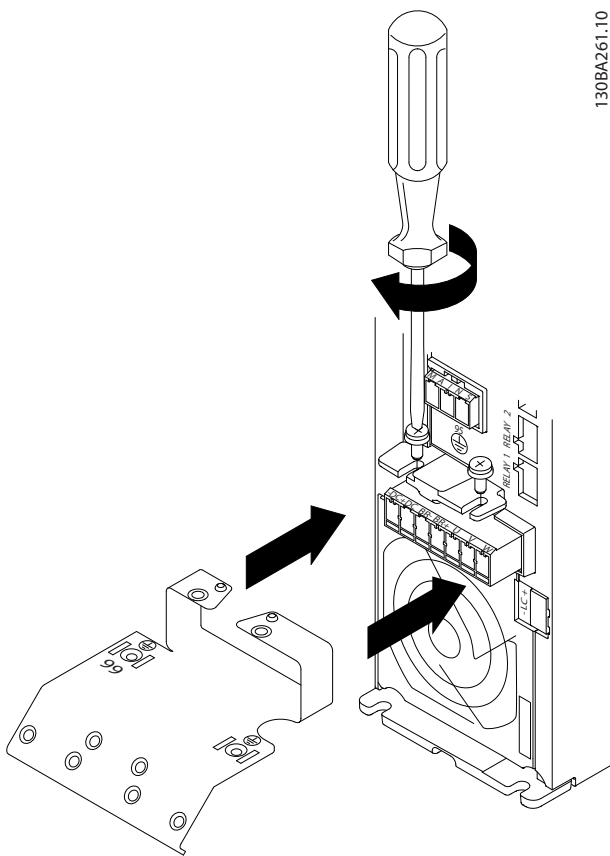

Figure 5.7 Mount the two screws in the mounting plate, slide it into place and tighten fully

130BA261.10

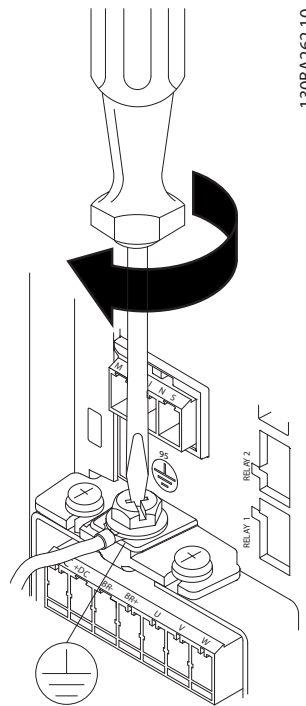

Figure 5.8 When mounting cables, first mount and tighten ground cable.

130BA262.10

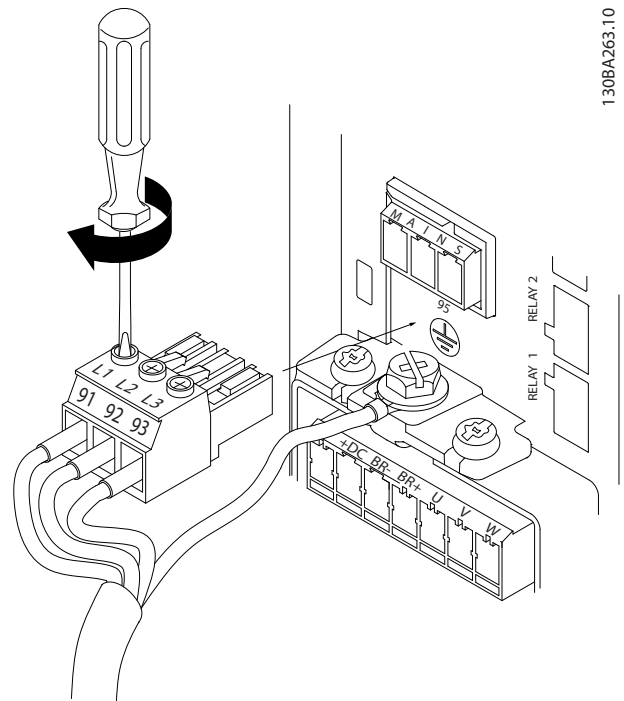

Figure 5.9 Mount line power plug and tighten wires

130BA263.10

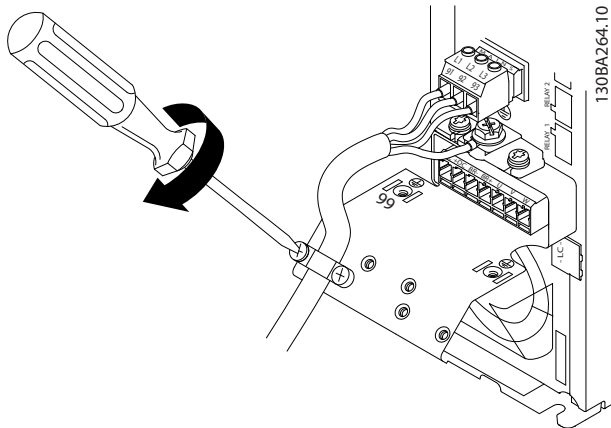

Figure 5.10 Tighten support bracket on line power wires.

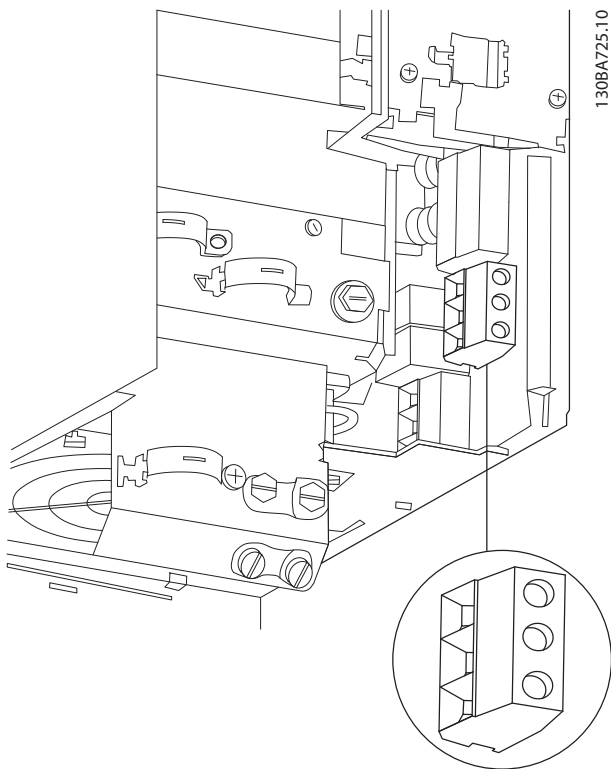

Figure 5.11 H10 Frame
IP20 600 V 15–20 hp [11–15 kW]

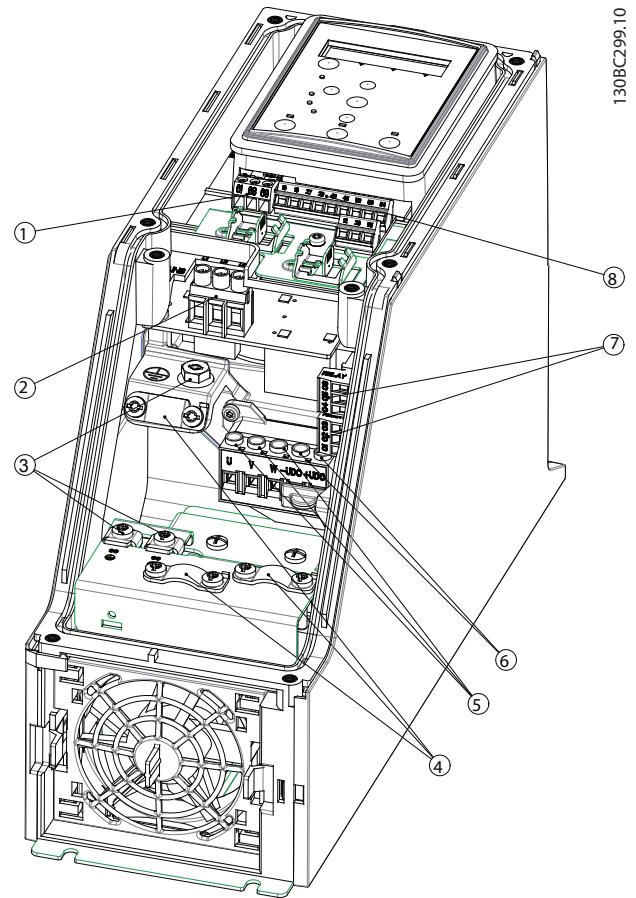

Figure 5.12 I2 Frame
IP54 380–480 V 1–5 hp [0.75–4.0 kW]

1	RS-485
2	Line in
3	Ground
4	Wire clamps
5	Motor
6	UDC
7	Relays
8	I/O

Table 5.11 Legend to Figure 5.12

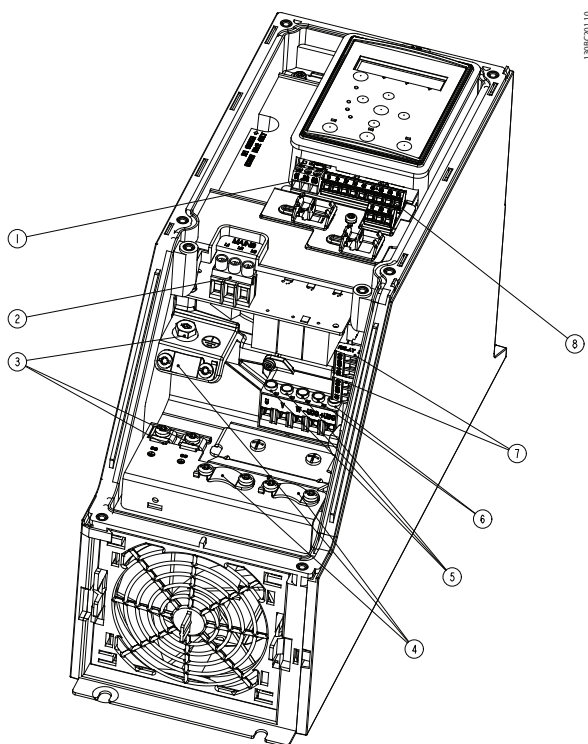

Figure 5.13 I3 Frame
IP54 380–480 V 75–100 hp [5.5–7.5 kW]

1	RS-485
2	Line in
3	Ground
4	Wire clamps
5	Motor
6	UDC
7	Relays
8	I/O

Table 5.12 Legend to Figure 5.13

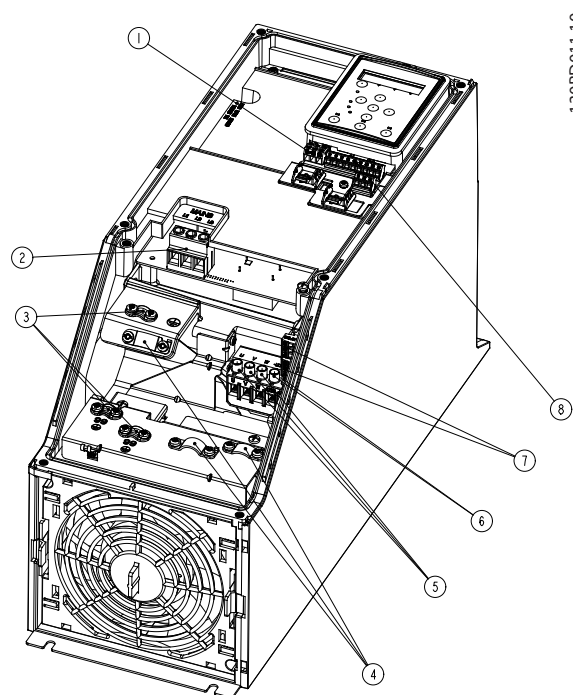

Figure 5.14 I4 Frame
IP54 380–480 V 1–5 hp [0.75–4.0 kW]

1	RS-485
2	Line in
3	Ground
4	Wire clamps
5	Motor
6	UDC
7	Relays
8	I/O

Table 5.13 Legend to Figure 5.14

5

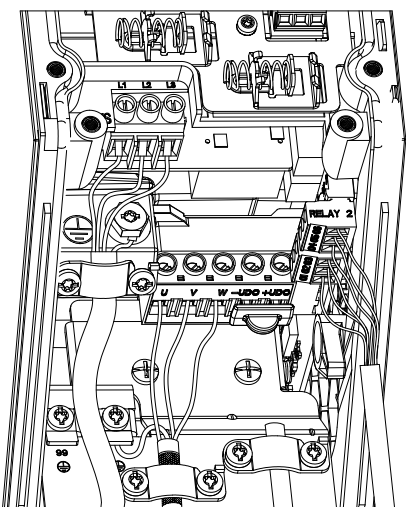
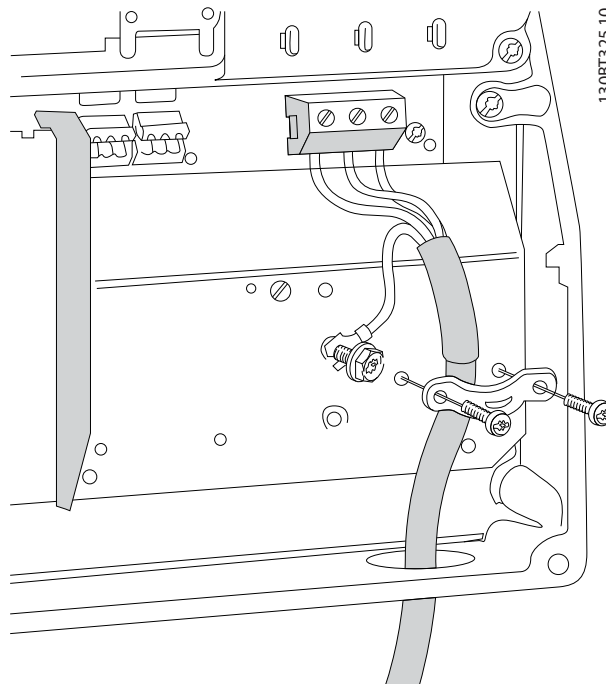

Figure 5.15 IP54 I2-I3-I4 frame

130BC203.10



130BT325.10

Figure 5.17 I6 Frame
IP54 380-480 V 30-50 hp [22-37 kW]

130BT326.10

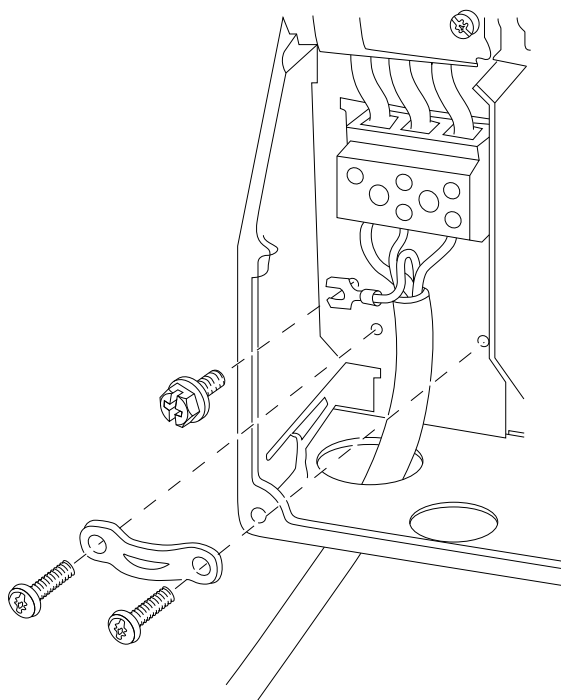

Figure 5.16 I6 Frame
IP54 380-480 V 30-50 hp [22-37 kW]

130BA215.10

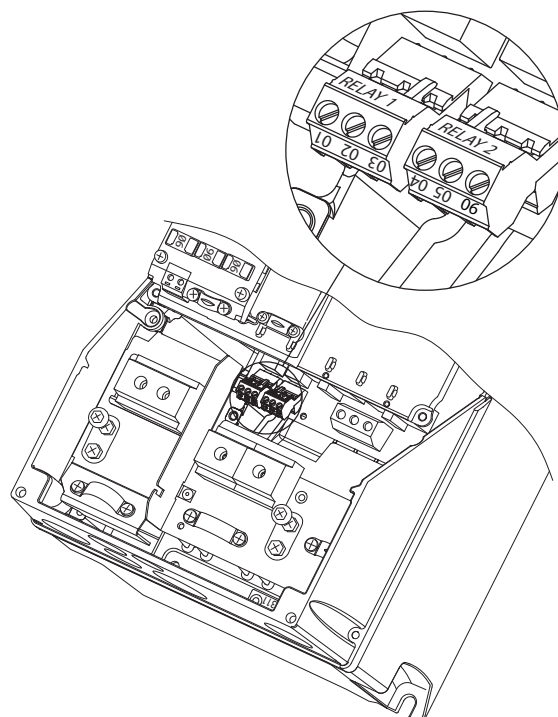

Figure 5.18 I6 Frame
IP54 380-480 V 30-50 hp [22-37 kW]

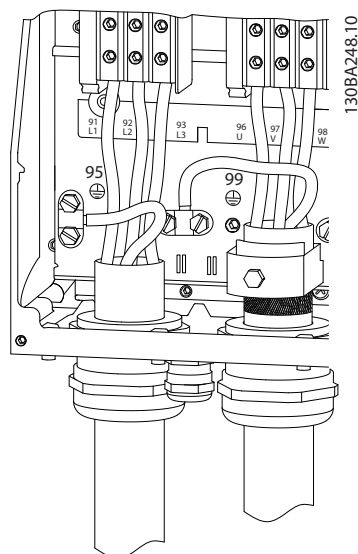

Figure 5.19 I7, I8 Frame
 IP54 380–480 V 60–75 hp [45–55 kW]
 IP54 380–480 V 100–125 hp [75–90 kW]

5.2.3 Fuses and Circuit Breakers

Branch circuit protection

To protect the installation against electrical and fire hazard, all branch circuits in an installation, switch gear, machines, etc., must be short-circuit and overcurrent protected according to national and local regulations.

Short circuit protection

Danfoss

Overcurrent protection

Provide overload protection to avoid overheating of the cables in the installation. Overcurrent protection must always be carried out according to local and national regulations. Circuit breakers and fuses must be designed for protection in a circuit capable of supplying a maximum of 100,000 A_{rms} (symmetrical), 480 V maximum.

UL/Non-UL compliance

Use the circuit breakers or fuses listed in *Table 5.14* to ensure compliance with UL or IEC 61800-5-1.

Circuit breakers must be designed for protection in a circuit capable of supplying a maximum of 10,000 A_{rms} (symmetrical), 480 V maximum.

NOTICE!

In the event of malfunction, failure to follow the protection recommendation may result in damage to the adjustable frequency drive.

	Circuit Breaker		Fuse				
	UL	Non-UL	UL				Non-UL
Power [kW]			Bussmann Type RK5	Bussmann Type RK1	Bussmann Type J	Bussmann Type T	Max fuse Type G
3x200-240 V IP20							
0.25			FRS-R-10	KTN-R10	JKS-10	JJN-10	10
0.37			FRS-R-10	KTN-R10	JKS-10	JJN-10	10
0.75			FRS-R-10	KTN-R10	JKS-10	JJN-10	10
1.5			FRS-R-10	KTN-R10	JKS-10	JJN-10	10
2.2			FRS-R-15	KTN-R15	JKS-15	JJN-15	16
3.7			FRS-R-25	KTN-R25	JKS-25	JJN-25	25
5.5			FRS-R-50	KTN-R50	JKS-50	JJN-50	50
7.5			FRS-R-50	KTN-R50	JKS-50	JJN-50	50
11			FRS-R-80	KTN-R80	JKS-80	JJN-80	65
15	Cutler-Hammer EGE3100FFG	Moeller NZMB1- A125	FRS-R-100	KTN-R100	JKS-100	JJN-100	125
18.5			FRS-R-100	KTN-R100	JKS-100	JJN-100	125
22	Cutler-Hammer JGE3150FFG	Moeller NZMB1- A160	FRS-R-150	KTN-R150	JKS-150	JJN-150	160
30			FRS-R-150	KTN-R150	JKS-150	JJN-150	160
37	Cutler-Hammer JGE3200FFG	Moeller NZMB1- A200	FRS-R-200	KTN-R200	JKS-200	JJN-200	200
45			FRS-R-200	KTN-R200	JKS-200	JJN-200	200

Table 5.14 Circuit Breakers and Fuses

	Circuit Breaker		Fuse				
	UL	Non-UL	UL				Non-UL
Power [kW]			Bussmann Type RK5	Bussmann Type RK1	Bussmann Type J	Bussmann Type T	Max fuse Type G
3x380–480 V IP20							
0.37			FRS-R-10	KTS-R10	JKS-10	JJS-10	10
0.75			FRS-R-10	KTS-R10	JKS-10	JJS-10	10
1.5			FRS-R-10	KTS-R10	JKS-10	JJS-10	10
2.2			FRS-R-15	KTS-R15	JKS-15	JJS-15	16
3			FRS-R-15	KTS-R15	JKS-15	JJS-15	16
4			FRS-R-15	KTS-R15	JKS-15	JJS-15	16
5.5			FRS-R-25	KTS-R25	JKS-25	JJS-25	25
7.5			FRS-R-25	KTS-R25	JKS-25	JJS-25	25
11			FRS-R-50	KTS-R50	JKS-50	JJS-50	50
15			FRS-R-50	KTS-R50	JKS-50	JJS-50	50
18.5			FRS-R-80	KTS-R80	JKS-80	JJS-80	65
22			FRS-R-80	KTS-R80	JKS-80	JJS-80	65
30	Cutler-Hammer EGE3125FFG	Moeller NZMB1- A125	FRS-R-125	KTS-R125	JKS-R125	JJS-R125	80
37			FRS-R-125	KTS-R125	JKS-R125	JJS-R125	100
45			FRS-R-125	KTS-R125	JKS-R125	JJS-R125	125
55	Cutler-Hammer JGE3200FFG	Moeller NZMB1- A200	FRS-R-200	KTS-R200	JKS-R200	JJS-R200	150
75			FRS-R-200	KTS-R200	JKS-R200	JJS-R200	200
90	Cutler-Hammer JGE3250FFG	Moeller NZMB2- A250	FRS-R-250	KTS-R250	JKS-R250	JJS-R250	250
3x525–600 V IP20							
2.2			FRS-R-20	KTS-R20	JKS-20	JJS-20	20
3			FRS-R-20	KTS-R20	JKS-20	JJS-20	20
5 [3.7]			FRS-R-20	KTS-R20	JKS-20	JJS-20	20
5.5			FRS-R-20	KTS-R20	JKS-20	JJS-20	20
7.5			FRS-R-20	KTS-R20	JKS-20	JJS-20	30
11			FRS-R-30	KTS-R30	JKS-30	JJS-30	35
15			FRS-R-30	KTS-R30	JKS-30	JJS-30	35
18.5	Cutler-Hammer EGE3080FFG	Cutler-Hammer EGE3080FFG	FRS-R-80	KTN-R80	JKS-80	JJS-80	80
22			FRS-R-80	KTN-R80	JKS-80	JJS-80	80
30			FRS-R-80	KTN-R80	JKS-80	JJS-80	80
37	Cutler-Hammer JGE3125FFG	Cutler-Hammer JGE3125FFG	FRS-R-125	KTN-R125	JKS-125	JJS-125	125
45			FRS-R-125	KTN-R125	JKS-125	JJS-125	125
55			FRS-R-125	KTN-R125	JKS-125	JJS-125	125
75	Cutler-Hammer JGE3200FAG	Cutler-Hammer JGE3200FAG	FRS-R-200	KTN-R200	JKS-200	JJS-200	200
90			FRS-R-200	KTN-R200	JKS-200	JJS-200	200
3x380–480 V IP54							
0.75		PKZM0-16	FRS-R-10	KTS-R-10	JKS-10	JJS-10	16
1.5		PKZM0-16	FRS-R-10	KTS-R-10	JKS-10	JJS-10	16
2.2		PKZM0-16	FRS-R-15	KTS-R-15	JKS-15	JJS-15	16
3		PKZM0-16	FRS-R-15	KTS-R-15	JKS-15	JJS-15	16
4		PKZM0-16	FRS-R-15	KTS-R-15	JKS-15	JJS-15	16
5.5		PKZM0-25	FRS-R-25	KTS-R-25	JKS-25	JJS-25	25
7.5		PKZM0-25	FRS-R-25	KTS-R-25	JKS-25	JJS-25	25
11		PKZM4-63	FRS-R-50	KTS-R-50	JKS-50	JJS-50	63
15		PKZM4-63	FRS-R-50	KTS-R-50	JKS-50	JJS-50	63

	Circuit Breaker		Fuse				
	UL	Non-UL	UL				Non-UL
Power [kW]			Bussmann Type RK5	Bussmann Type RK1	Bussmann Type J	Bussmann Type T	Max fuse Type G
18.5		PKZM4-63	FRS-R-80	KTS-R-80	JKS-80	JJS-80	63
22	Moeller NZMB1-A125		FRS-R-80	KTS-R-80	JKS-80	JJS-80	125
30			FRS-R-125	KTS-R-125	JKS-125	JJS-125	125
37			FRS-R-125	KTS-R-125	JKS-125	JJS-125	125
45	Moeller NZMB2-A160		FRS-R-125	KTS-R-125	JKS-125	JJS-125	160
55			FRS-R-200	KTS-R-200	JKS-200	JJS-200	160
75	Moeller NZMB2-A250		FRS-R-200	KTS-R-200	JKS-200	JJS-200	200
90			FRS-R-250	KTS-R-250	JKS-200	JJS-200	200

Table 5.15 Circuit Breakers and Fuses

5.2.4 EMC-compatible Electrical Installation

General points to be observed to ensure EMC-compatible electrical installation.

- Use only shielded/armored motor cables and shielded/armored control cables.
- Connect the shield to ground at both ends.
- Avoid installation with twisted shield ends (pigtailed), since this ruins the shielding effect at high frequencies. Use the cable clamps provided instead.
- It is important to ensure good electrical contact from the installation plate through the installation screws to the metal cabinet of the adjustable frequency drive.
- Use starwashers and galvanically conductive installation plates.
- Do not use shielded/armored motor cables in the installation cabinets.

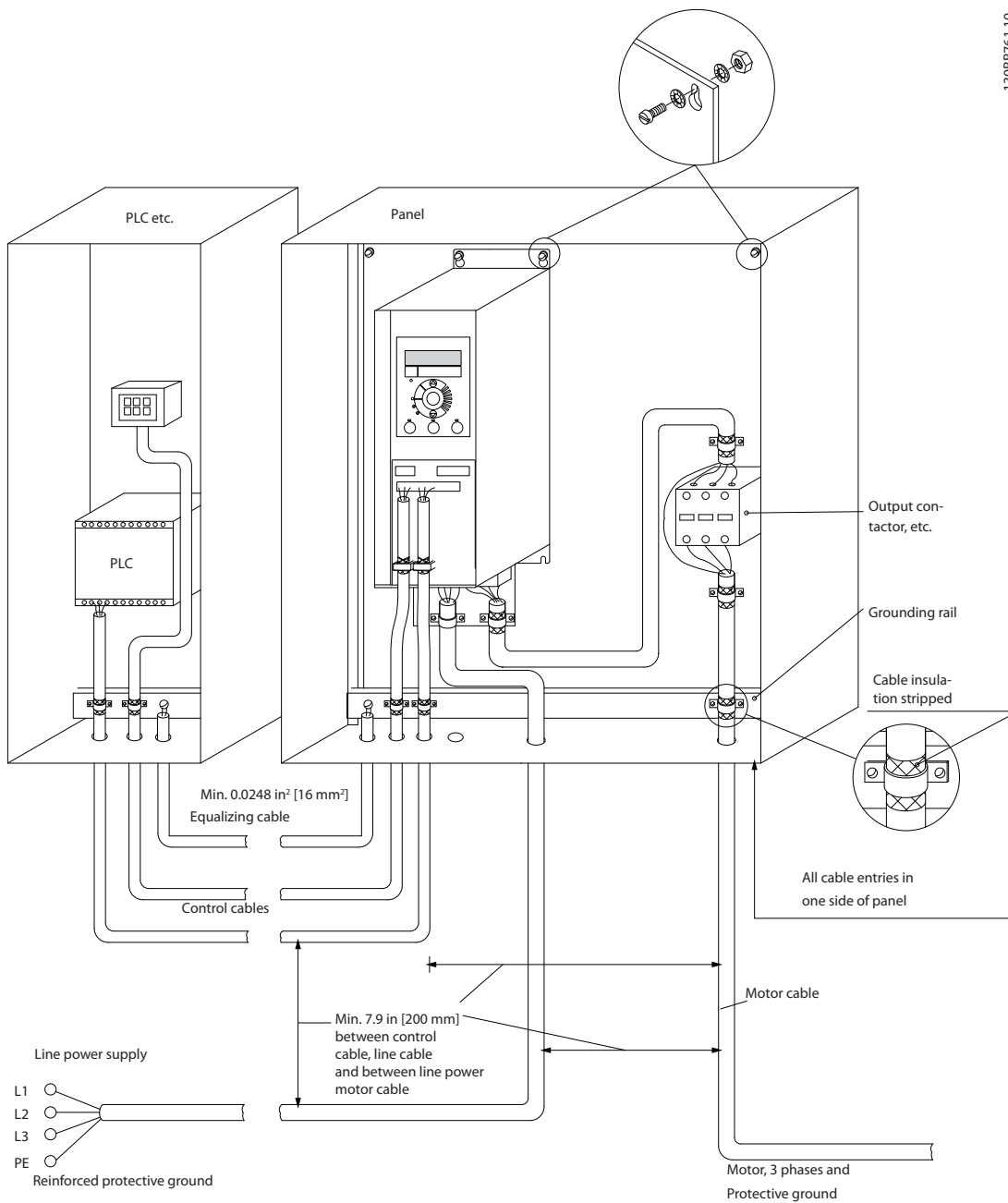

Figure 5.20 EMC-compatible Electrical Installation

NOTICE!

For North America, use metal conduits instead of shielded cables.

5.2.5 Control Terminals

IP20 200–240 V 0.34–15 hp [0.25–11 kW] and IP20 380–480 V 0.5–30 hp [0.37–22 kW]:

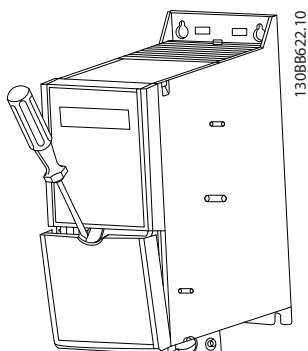

Figure 5.21 Location of Control Terminals

1. Place a screwdriver behind the terminal cover to activate snap.
2. Tilt the screwdriver outwards to open the cover.

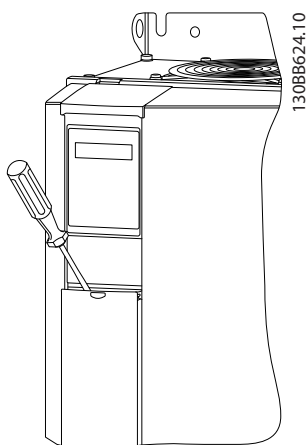

Figure 5.22 IP20 380–480 V 40–125 hp [30–90 kW]

1. Place a screwdriver behind the terminal cover to activate snap.
2. Tilt the screwdriver outwards to open the cover.

Digital input 18, 19 and 27 mode is set in 5-00 *Digital Input Mode* (PNP is default value) and digital input 29 mode is set in 5-03 *Digital Input 29 Mode* (PNP is default value).

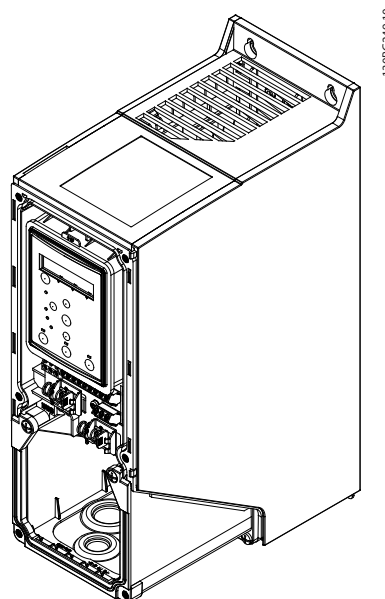

Figure 5.23 IP54 400 V 1–10 hp [0.75–7.5 kW]

1. Remove the front cover.

Control terminals

Figure 5.24 shows all control terminals of the adjustable frequency drive. Applying Start (term. 18), connection between terminal 12-27 and an analog reference (term. 53 or 54 and 55) make the adjustable frequency drive run.

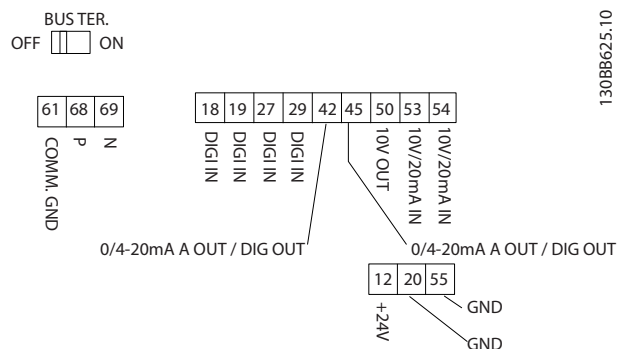

Figure 5.24 Control Terminals

6 How to Program

6.1 Programming with MCT 10 Set-up Software

The adjustable frequency drive can be programmed from a PC via RS-485 COM port by using the MCT 10 Set-up Software. This software can either be ordered using code number 130B1000 or downloaded from www.danfoss.com/BusinessAreas/DrivesSolutions/softwaredownload.

6.2 Local Control Panel (LCP)

The LCP is divided into four functional sections.

- A. Display
- B. Menu key
- C. Navigation keys and LEDs
- D. Operation keys and LEDs

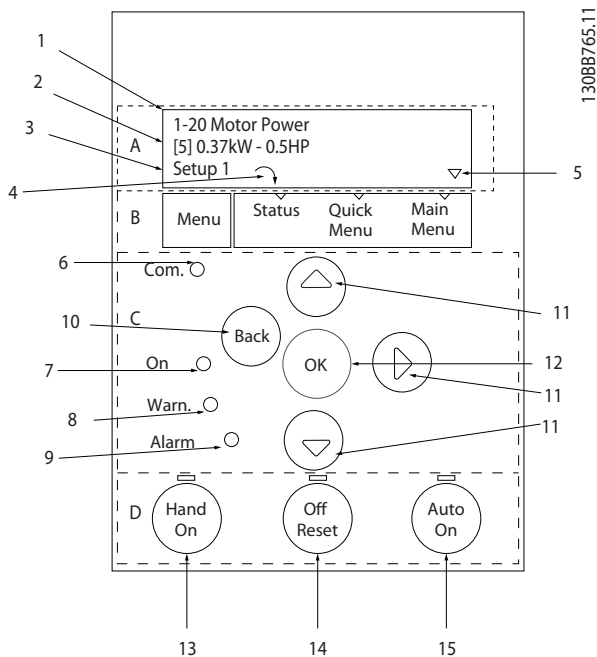

Figure 6.1 Local Control Panel (LCP)

A. Display

The LCD display is backlit with two alphanumeric lines. All data is displayed on the LCP.

Information can be read from the display.

1	Parameter number and name.
2	Parameter value.
3	Set-up number shows the active set-up and the edit set-up. If the same set-up acts as both the active and edit set-up, only that set-up number is shown (factory setting). When active and edit set-up differ, both numbers are shown in the display (Set-up 12). The flashing number indicates the edit set-up.
4	Motor direction is shown to the bottom left of the display – indicated by a small arrow pointing either clockwise or counter-clockwise.
5	The triangle indicates if the LCP is in status quick menu or main menu.

Table 6.1 Legend to Figure 6.1

B. Menu key

Press [Menu] to select between status, quick menu or main menu.

C. Navigation keys and LEDs

6	Com LED: Flashes when bus communication is communicating.
7	Green LED/On: Control section is working.
8	Yellow LED/Warn.: Indicates a warning.
9	Flashing Red LED/Alarm: Indicates an alarm.
10	[Back]: For moving to the previous step or layer in the navigation structure.
11	[▲] [▼] [▶]: For navigating between parameter groups, parameters and within parameters. Can also be used for setting local reference.
12	[OK]: For selecting a parameter and for accepting changes to parameter settings.

Table 6.2 Legend to Figure 6.1

D. Operation keys and LEDs

13	[Hand On]: Starts the motor and enables control of the adjustable frequency drive via the LCP.
14	[Off/Reset]: Stops the motor (Off). If in alarm mode, the alarm is reset.
15	[Auto On]: The adjustable frequency drive is controlled either via control terminals or serial communication.

Table 6.3 Legend to Figure 6.1

6.3 Menus

6.3.1 Status Menu

In the Status menu, the selection options are:

- Motor Frequency [Hz], 16-13 Frequency
- Motor Current [A], 16-14 Motor current
- Motor Speed Reference in Percentage [%], 16-02 Reference [%]
- Feedback, 16-52 Feedback[Unit]
- Motor Power [kW] (if 0-03 Regional Settings is set to [1] North America, Motor Power is shown in the unit of hp instead of kW), 16-10 Power [kW] for kW, 16-11 Power [hp] for hp
- Custom Readout 16-09 Custom Readout

6.3.2 Quick Menu

Use the Quick Menu to program the most common VLT® HVAC Basic Drive functions. The Quick Menu consists of:

- Wizard for open-loop applications
- Closed-loop set-up wizard
- Motor set-up
- Changes made

6.3.3 Start-up Wizard for Open-loop Applications

The built-in wizard menu guides the installer through the set-up of the adjustable frequency drive to an open-loop application. An open-loop application is here an application with a start signal, analog reference (voltage or current) and optionally also relay signals (but no feedback signal from the process applied).

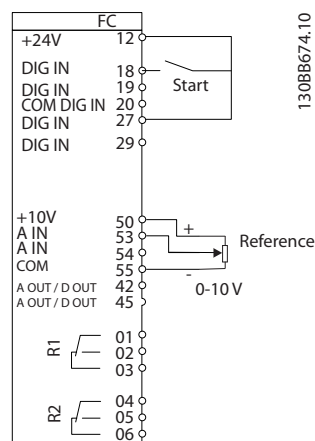

Figure 6.2 Set-up of the Adjustable Frequency Drive

The wizard is initially shown after power-up until any parameter has been changed. The wizard can always be accessed again through the Quick Menu. Press [OK] to start the wizard. Press [Back] to return to the status screen.

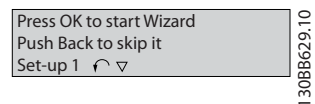

Figure 6.3 Wizard

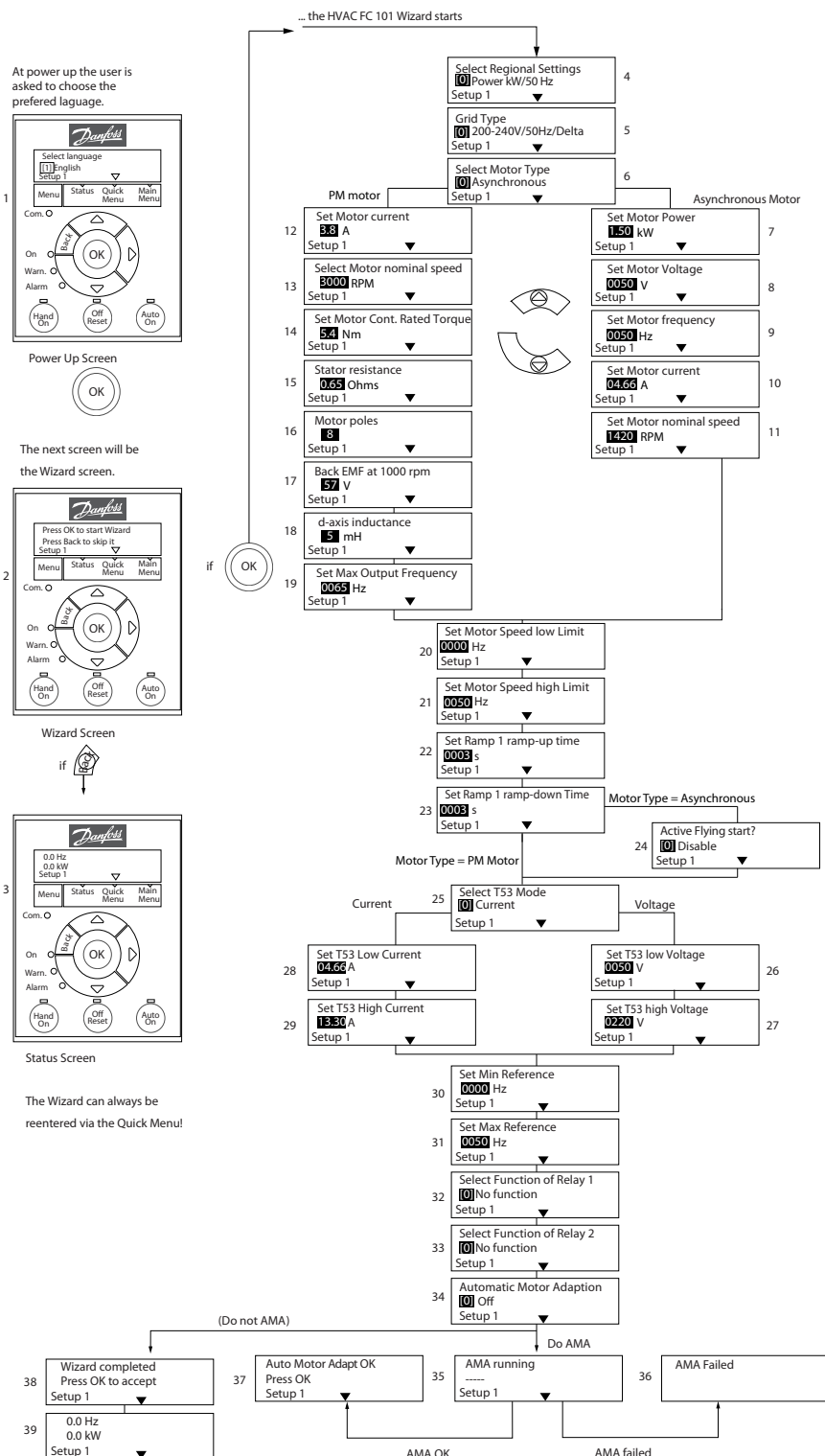

Figure 6.4 Open-loop Set-up Wizard

Start-up Wizard for Open-loop Applications

Parameter	Range	Default	Function
0-03 Regional Settings	[0] International [1] US	0	
0-06 GridType	[0] 200–240 V/50 Hz/IT grid [1] 200–240 V/50 Hz/Delta [2] 200–240 V/50 Hz [10] 380–440 V/50 Hz/IT grid [11] 380–440 V/50 Hz/Delta [12] 380–440 V/50 Hz [20] 440–480 V/50 Hz/IT grid [21] 440–480 V/50 Hz/Delta [22] 440–480 V/50 Hz [30] 525–600 V/50 Hz/IT grid [31] 525–600 V/50 Hz/Delta [32] 525–600 V/50 Hz [100] 200–240 V/60 Hz/IT grid [101] 200–240 V/60 Hz/Delta [102] 200–240 V/60 Hz [110] 380–440 V/60 Hz/IT grid [111] 380–440 V/60 Hz/Delta [112] 380–440 V/60 Hz [120] 440–480 V/60 Hz/IT grid [121] 440–480 V/60 Hz/Delta [122] 440–480 V/60 Hz [130] 525–600 V/60 Hz/IT grid [131] 525–600 V/60 Hz/Delta [132] 525–600 V/60 Hz	Size related	Select operating mode for restart upon reconnection of the adjustable frequency drive to AC line voltage after power-down.
1-10 Motor Construction	*[0] Asynchron [1] PM, non-salient SPM	[0] Asynchron	Setting the parameter value might change these parameters: 1-01 Motor Control Principle 1-03 Torque Characteristics 1-14 Damping Gain 1-15 Low Speed Filter Time Const 1-16 High Speed Filter Time Const 1-17 Voltage filter time const 1-20 Motor Power 1-22 Motor Voltage 1-23 Motor Frequency 1-24 Motor Current 1-25 Motor Nominal Speed 1-26 Motor Cont. Rated Torque 1-30 Stator Resistance (Rs) 1-33 Stator Leakage Reactance (X1) 1-35 Main Reactance (Xh) 1-37 d-axis Inductance (Ld) 1-39 Motor Poles 1-40 Back EMF at 1000 RPM 1-66 Min. Current at Low Speed 1-72 Start Function 1-73 Flying Start 4-19 Max Output Frequency 4-58 Missing Motor Phase Function

Parameter	Range	Default	Function
1-20 Motor Power	0.12–110 kW/0.16–150 hp	Size related	Enter motor power from nameplate data.
1-22 Motor Voltage	50.0–1000.0 V	Size related	Enter motor voltage from nameplate data.
1-23 Motor Frequency	20.0–400.0 Hz	Size related	Enter motor frequency from nameplate data.
1-24 Motor Current	0.01–10000.00 A	Size related	Enter motor current from nameplate data.
1-25 Motor Nominal Speed	100.0–9999.0 RPM	Size related	Enter motor nominal speed from nameplate data.
1-26 Motor Cont. Rated Torque	0.1–1000.0	Size related	This parameter is available only when <i>1-10 Motor Construction Design</i> is set to <i>[1] PM, non-salient SPM</i> . NOTICE! Changing this parameter affects the settings of other parameters.
1-29 Automatic Motor Adaption (AMA)	See 1-29 Automatic Motor Adaption (AMA)	Off	Performing an AMA optimizes motor performance.
1-30 Stator Resistance (Rs)	0.000–99.990	Size related	Set the stator resistance value.
1-37 d-axis Inductance (Ld)	0–1000	Size related	Enter the value of the d-axis inductance. Obtain the value from the permanent magnet motor data sheet. The de-axis inductance cannot be found by performing an AMA.
1-39 Motor Poles	2–100	4	Enter the number of motor poles.
1-40 Back EMF at 1000 RPM	10–9000	Size related	Line-Line RMS back EMF voltage at 1000 RPM.
1-73 Flying Start			When PM is selected, Flying Start is enabled and cannot disable.
1-73 Flying Start	[0] Disabled [1] Enabled	0	Select <i>[1] Enable</i> to enable the adjustable frequency drive to catch a motor spinning due to line drop-out. Select <i>[0] Disable</i> if this function is not required. When is enabled <i>1-71 Start Delay</i> and <i>1-72 Start Function</i> have no function. is active in VVC ^{plus} mode only.
3-02 Minimum Reference	-4999–4999	0	The minimum reference is the lowest value obtainable by summing all references.
3-03 Maximum Reference	-4999–4999	50	The maximum reference is the lowest obtainable by summing all references.
3-41 Ramp 1 Ramp Up Time	0.05–3600.0 s	Size related	Ramp-up time from 0 to rated <i>1-23 Motor Frequency</i> if Asynchron motor is selected; ramp-up time from 0 to <i>1-25 Motor Nominal Speed</i> if PM motor is selected.
3-42 Ramp 1 Ramp Down Time	0.05–3600.0 s	Size related	Ramp-down time from rated <i>1-23 Motor Frequency</i> to 0 if Asynchron motor is selected; ramp-down time from <i>1-25 Motor Nominal Speed</i> to 0 if PM motor is selected.
4-12 Motor Speed Low Limit [Hz]	0.0–400 Hz	0 Hz	Enter the minimum limit for low speed.
4-14 Motor Speed High Limit [Hz]	0.0–400 Hz	65 Hz	Enter the maximum limit for high speed.
4-19 Max Output Frequency	0–400	Size related	Enter the maximum output frequency value.

Parameter	Range	Default	Function
5-40 Function Relay [0] Function relay	See 5-40 Function Relay	Alarm	Select the function to control output relay 1.
5-40 Function Relay [1] Function relay	See 5-40 Function Relay	Drive running	Select the function to control output relay 2.
6-10 Terminal 53 Low Voltage	0–10 V	0.07 V	Enter the voltage that corresponds to the low reference value.
6-11 Terminal 53 High Voltage	0–10 V	10 V	Enter the voltage that corresponds to the high reference value.
6-12 Terminal 53 Low Current	0–20 mA	4	Enter the current that corresponds to the low reference value.
6-13 Terminal 53 High Current	0–20 mA	20	Enter the current that corresponds to the high reference value.
6-19 Terminal 53 mode	[0] Current [1] Voltage	1	Select if terminal 53 is used for current or voltage input.

Table 6.4 Open-loop Application

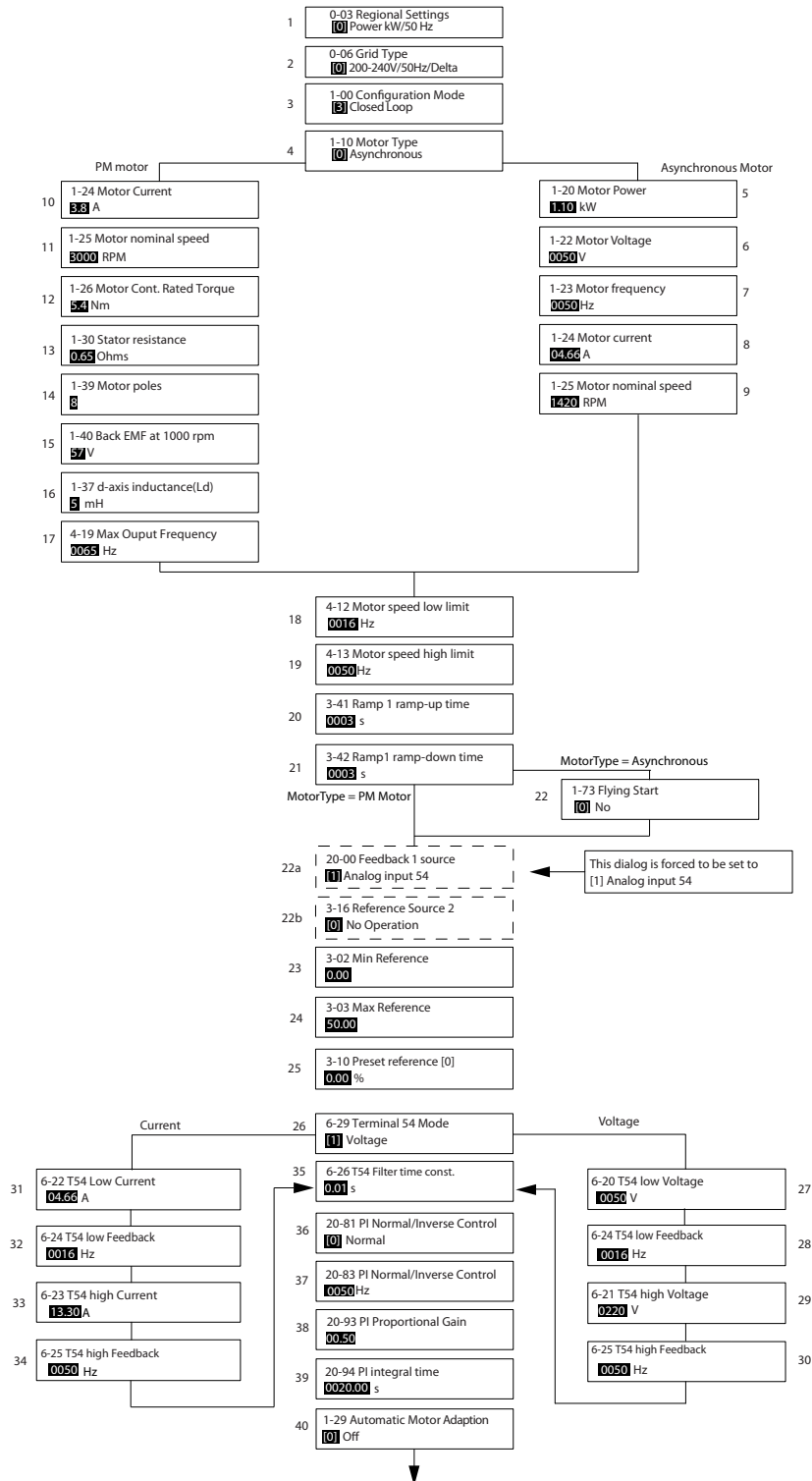

Figure 6.5 Closed-loop Set-up Wizard

Closed-loop Set-up Wizard

Parameter	Range	Default	Function
0-03 Regional Settings	[0] International [1] US	0	
0-06 GridType	[0] -[[132] see start-up wizard for open-loop application	Size selected	Select operating mode for restart upon reconnection of the adjustable frequency drive to AC line voltage after power-down.
1-00 Configuration Mode	[0] Open-loop [3] Closed-loop	0	Change this parameter to Closed-loop.
1-10 Motor Construction	*[0] Motor construction [1] PM, non-salient SPM	[0] Asynchron	Setting the parameter value might change these parameters: 1-01 Motor Control Principle 1-03 Torque Characteristics 1-14 Damping Gain 1-15 Low Speed Filter Time Const 1-16 High Speed Filter Time Const 1-17 Voltage filter time const 1-20 Motor Power 1-22 Motor Voltage 1-23 Motor Frequency 1-25 Motor Nominal Speed 1-26 Motor Cont. Rated Torque 1-30 Stator Resistance (Rs) 1-33 Stator Leakage Reactance (X1) 1-35 Main Reactance (Xh) 1-37 d-axis Inductance (Ld) 1-39 Motor Poles 1-40 Back EMF at 1000 RPM 1-66 Min. Current at Low Speed 1-72 Start Function 1-73 Flying Start 4-19 Max Output Frequency 4-58 Missing Motor Phase Function
1-20 Motor Power	0.09–110 kW	Size related	Enter motor power from nameplate data.
1-22 Motor Voltage	50.0–1000.0 V	Size related	Enter motor voltage from nameplate data.
1-23 Motor Frequency	20.0–400.0 Hz	Size related	Enter motor frequency from nameplate data.
1-24 Motor Current	0.0–10000.00 A	Size related	Enter motor current from nameplate data.
1-25 Motor Nominal Speed	100.0–9999.0 RPM	Size related	Enter motor nominal speed from nameplate data.
1-26 Motor Cont. Rated Torque	0.1–1000.0	Size related	This parameter is available only when <i>1-10 Motor Construction Design</i> is set to [1] <i>PM, non-salient SPM</i> . NOTICE! Changing this parameter affects the settings of other parameters.
1-29 Automatic Motor Adaption (AMA)		Off	Performing an AMA optimizes motor performance.
1-30 Stator Resistance (Rs)	0.000–99.990	Size related	Set the stator resistance value.

Parameter	Range	Default	Function
1-37 d-axis Inductance (Ld)	0–1000	Size related	Enter the value of the d-axis inductance. Obtain the value from the permanent magnet motor data sheet. The de-axis inductance cannot be found by performing an AMA.
1-39 Motor Poles	2–100	4	Enter the number of motor poles.
1-40 Back EMF at 1000 RPM	10–9000	Size related	Line-Line RMS back EMF voltage at 1000 RPM.
1-73 Flying Start	[0] Disabled [1] Enabled	0	Select [1] <i>Enable</i> to enable the adjustable frequency drive to catch a spinning motor, e.g., in fan applications. When PM is selected, Flying Start is enabled.
3-02 Minimum Reference	-4999–4999	0	The minimum reference is the lowest value obtainable by summing all references.
3-03 Maximum Reference	-4999–4999	50	The maximum reference is the highest value obtainable by summing all references.
3-10 Preset Reference	-100–100%	0	Enter the setpoint.
3-41 Ramp 1 Ramp Up Time	0.05–3600.0 s	Size related	Ramp-up time from 0 to rated 1-23 <i>Motor Frequency</i> if Asynchron motor is selected; ramp-up time from 0 to 1-25 <i>Motor Nominal Speed</i> if PM motor is selected.
3-42 Ramp 1 Ramp Down Time	0.05–3600.0 s	Size related	Ramp-down time from rated 1-23 <i>Motor Frequency</i> to 0 if Asynchron motor is selected; ramp-down time from 1-25 <i>Motor Nominal Speed</i> to 0 if PM motor is selected.
4-12 Motor Speed Low Limit [Hz]	0.0–400 Hz	0.0 Hz	Enter the minimum limit for low speed.
4-14 Motor Speed High Limit [Hz]	0–400 Hz	65 Hz	Enter the minimum limit for high speed.
4-19 Max Output Frequency	0–400	Size related	Enter the maximum output frequency value.
6-29 Terminal 54 mode	[0] Current [1] Voltage	1	Select if terminal 54 is used for current or voltage input.
6-20 Terminal 54 Low Voltage	0–10 V	0.07 V	Enter the voltage that corresponds to the low reference value.
6-21 Terminal 54 High Voltage	0–10 V	10 V	Enter the voltage that corresponds to the low high reference value.
6-22 Terminal 54 Low Current	0–20 mA	4	Enter the current that corresponds to the high reference value.
6-23 Terminal 54 High Current	0–20 mA	20	Enter the current that corresponds to the high reference value.
6-24 Terminal 54 Low Ref./Feedb. Value	-4999–4999	0	Enter the feedback value that corresponds to the voltage or current set in 6-20 <i>Terminal 54 Low Voltage</i> /6-22 <i>Terminal 54 Low Current</i>
6-25 Terminal 54 High Ref./Feedb. Value	-4999–4999	50	Enter the feedback value that corresponds to the voltage or current set in 6-21 <i>Terminal 54 High Voltage</i> /6-23 <i>Terminal 54 High Current</i>
6-26 Terminal 54 Filter Time Constant	0–10 s	0.01	Enter the filter time constant.
20-81 PI Normal/ Inverse Control	[0] Normal [1] Inverse	0	Select [0] <i>Normal</i> to set the process control to increase the output speed when the process error is positive. Select [1] <i>Inverse</i> to reduce the output speed.
20-83 PI Start Speed [Hz]	0–200 Hz	0	Enter the motor speed to be attained as a start signal for commencement of PI control.

Parameter	Range	Default	Function
20-93 PI Proportional Gain	0–10	0.01	Enter the process controller proportional gain. Quick control is obtained at high amplification. However, if amplification is too great, the process may become unstable.
20-94 PI Integral Time	0.1–999.0 s	999.0 s	Enter the process controller integral time. Obtain quick control through a short integral time, though if the integral time is too short, the process becomes unstable. An excessively long integral time disables the integral action.

Table 6.5 Closed-loop Application

6

Motor Set-up

The Quick Menu Motor Set-up guides you through the needed motor parameters.

Parameter	Range	Default	Function
0-03 Regional Settings	[0] International [1] US	0	
0-06 GridType	[0] -[132] see start-up wizard for open-loop application	Size selected	Select operating mode for restart upon reconnection of the adjustable frequency drive to AC line voltage after power-down.
1-10 Motor Construction	*[0] Motor construction [1] PM, non-salient SPM	[0] Asynchron	
1-20 Motor Power	0.12–110 kW/0.16–150 hp	Size related	Enter motor power from nameplate data
1-22 Motor Voltage	50.0–1000.0 V	Size related	Enter motor voltage from nameplate data
1-23 Motor Frequency	20.0–400.0 Hz	Size related	Enter motor frequency from nameplate data
1-24 Motor Current	0.01–10000.00 A	Size related	Enter motor current from nameplate data
1-25 Motor Nominal Speed	100.0–9999.0 RPM	Size related	Enter motor nominal speed from nameplate data
1-26 Motor Cont. Rated Torque	0.1–1000.0	Size related	This parameter is available only when <i>1-10 Motor Construction Design</i> is set to <i>[1] PM, non-salient SPM</i> . NOTICE! Changing this parameter affects the settings of other parameters
1-30 Stator Resistance (Rs)	0.000–99.990	Size related	Set the stator resistance value
1-37 d-axis Inductance (Ld)	0–1000	Size related	Enter the value of the d-axis inductance. Obtain the value from the permanent magnet motor data sheet. The de-axis inductance cannot be found by performing an AMA.
1-39 Motor Poles	2–100	4	Enter the number of motor poles
1-40 Back EMF at 1000 RPM	10–9000	Size related	Line-Line RMS back EMF voltage at 1000 RPM

Parameter	Range	Default	Function
1-73 Flying Start	[0] Disabled [1] Enabled	0	Select [1] <i>Enable</i> to enable the adjustable frequency drive to catch a spinning motor
3-41 Ramp 1 Ramp Up Time	0.05–3600.0 s	Size related	Ramp-up time from 0 to rated <i>1-23 Motor Frequency</i>
3-42 Ramp 1 Ramp Down Time	0.05–3600.0 s	Size related	Ramp-down time from rated <i>1-23 Motor Frequency</i> to 0
4-12 Motor Speed Low Limit [Hz]	0.0–400 Hz	0.0 Hz	Enter the minimum limit for low speed
4-14 Motor Speed High Limit [Hz]	0.0–400 Hz	2.56 [65]	Enter the maximum limit for high speed
4-19 Max Output Frequency	0–400	Size related	Enter the maximum output frequency value

Table 6.6 Motor Parameters

Changes Made

Changes Made lists all parameters changed since factory setting. Only the changed parameters in current edit-setup are listed in changes made.

If the parameter's value is changed back to the factory settings from another different value, the parameter will NOT be listed in Changes Made.

1. Press [Menu] to enter the Quick Menu until indicator in display is placed above Quick Menu.
2. Press [▲] [▼] to select either wizard, closed-loop set-up, motor set-up or changes made, then press [OK].
3. Press [▲] [▼] to browse through the parameters in the Quick Menu.
4. Press [OK] to select a parameter.
5. Press [▲] [▼] to change the value of a parameter setting.
6. Press [OK] to accept the change.
7. Press either [Back] twice to enter "Status", or press [Menu] once to enter "Main Menu".

6.3.4 Main Menu

[Main Menu] is used for access to and programming of all parameters. The Main Menu parameters can be accessed readily unless a password has been created via *0-60 Main Menu Password*.

For the majority of VLT[®] HVAC Basic Drive applications, it is not necessary to access the Main Menu parameters but instead the Quick Menu provides the simplest and quickest access to the typical required parameters.

The Main Menu accesses all parameters.

1. Press [Menu] until indicator in display is placed above "Main Menu".
2. Press [▲] [▼] to browse through the parameter groups.
3. Press [OK] to select a parameter group.
4. Press [▲] [▼] to browse through the parameters in the specific group.
5. Press [OK] to select the parameter.
6. Press [▲] [▼] to set/change the parameter value.

Press [Back] to go back one level.

6.4 Quick Transfer of Parameter Settings between Multiple Adjustable Frequency Drives

Once the set-up of an adjustable frequency drive is complete, Danfoss recommends to store the data in the LCP or on a PC via MCT 10 Set-up Software tool.

Data transfer from adjustable frequency drive to LCP:



Stop the motor before performing this operation.

1. Go to *0-50 LCP Copy*
2. Press [OK]
3. Select *[1] All to LCP*
4. Press [OK]

Connect the LCP to another adjustable frequency drive and copy the parameter settings to this adjustable frequency drive as well.

Data transfer from LCP to adjustable frequency drive:



Stop the motor before performing this operation.

1. Go to *0-50 LCP Copy*
2. Press [OK]
3. Select *[2] All from LCP*
4. Press [OK]

6.5 Readout and Programming of Indexed Parameters

Select the parameter, press [OK], and press [▲]/[▼] to scroll through the indexed values. To change the parameter value, select the indexed value and press [OK]. Change the value by pressing [▲]/[▼]. Press [OK] to accept the new setting. Press [Cancel] to abort. Press [Back] to leave the parameter.

6.6 Initialize the Adjustable Frequency Drive to Default Settings in Two Ways

Recommended initialization (via 14-22 Operation Mode)

1. Select 14-22 Operation Mode.
2. Press [OK].
3. Select [2] Initialization and Press [OK].
4. Cut off the line power supply and wait until the display turns off.
5. Reconnect the line power supply - the adjustable frequency drive is now reset.

Except the following parameters:

- 8-30 Protocol
- 8-31 Address
- 8-32 Baud Rate
- 8-33 Parity / Stop Bits
- 8-35 Minimum Response Delay
- 8-36 Maximum Response Delay
- 8-37 Maximum Inter-char delay
- 8-70 BACnet Device Instance
- 8-72 MS/TP Max Masters
- 8-73 MS/TP Max Info Frames
- 8-74 "I am" Service
- 8-75 Intialisation Password
- 15-00 Operating hours to 15-05 Over Volt's
- 15-03 Power Up's
- 15-04 Over Temp's
- 15-05 Over Volt's
- 15-30 Alarm Log: Error Code
- 15-4* Drive identification parameters
- 1-06 Clockwise Direction

Two finger initialization

1. Power off the adjustable frequency drive.
2. Press [OK] and [Menu].
3. Power up the adjustable frequency drive while still pressing the keys above for 10 s.
4. The adjustable frequency drive is now reset, except the following parameters:
 - 15-00 Operating hours
 - 15-03 Power Up's
 - 15-04 Over Temp's
 - 15-05 Over Volt's
 - 15-4* Drive identification parameters

Initialization of parameters is confirmed by AL80 in the display after the power cycle.

7 RS-485 Installation and Set-up

7.1 RS-485

7.1.1 Overview

RS-485 is a two-wire bus interface compatible with multi-drop network topology, that is, nodes can be connected as a bus, or via drop cables from a common trunk line. A total of 32 nodes can be connected to one network segment.

Repeaters divide network segments.

NOTICE!

Each repeater functions as a node within the segment in which it is installed. Each node connected within a given network must have a unique node address across all segments.

Terminate each segment at both ends using either the termination switch (S801) of the adjustable frequency drives or a biased termination resistor network. Always use shielded twisted pair (STP) cable for bus cabling, and always follow good common installation practice.

Low-impedance ground connection of the shield at every node is important, including at high frequencies. Thus, connect a large surface of the shield to ground, for example, with a cable clamp or a conductive cable connector. It may be necessary to apply potential-equalizing cables to maintain the same ground potential throughout the network - particularly in installations with long cables.

To prevent impedance mismatch, always use the same type of cable throughout the entire network. When connecting a motor to the adjustable frequency drive, always use shielded motor cable.

Cable	Shielded twisted pair (STP)
Impedance [Ω]	120
Cable length (ft [m])	Max. 4,000 ft [1200 m] (including drop lines) Max. 1,650 ft [500 m] station-to-station

Table 7.1 Cable

7.1.2 Network Connection

Connect the adjustable frequency drive to the RS-485 network as follows (see also *Figure 7.1*):

1. Connect signal wires to terminal 68 (P+) and terminal 69 (N-) on the main control board of the adjustable frequency drive.
2. Connect the cable shield to the cable clamps.

NOTICE!

Shielded, twisted-pair cables are recommended to reduce noise between conductors.

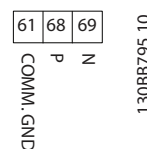

Figure 7.1 Network Connection

7.1.3 Adjustable Frequency Drive Hardware Set-up

Use the terminator dip switch on the main control board of the adjustable frequency drive to terminate the RS-485 bus.

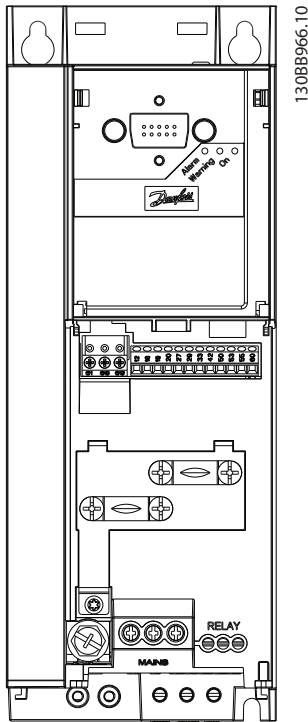

Figure 7.2 Terminator Switch Factory Setting

The factory setting for the dip switch is OFF.

7.1.4 Adjustable Frequency Drive Parameter Settings for Modbus Communication

Define the RS-485 Communication Set-up

Parameter	Function
8-30 Protocol	Select the application protocol to run on the RS-485 interface.
8-31 Address	Set the node address. NOTICE! The address range depends on the protocol selected in <i>8-30 Protocol</i>
8-32 Baud Rate	Set the baud rate. NOTICE! The default baud rate depends on the protocol selected in <i>8-30 Protocol</i>
8-33 Parity / Stop Bits	Set the parity and number of stop bits. NOTICE! The default selection depends on the protocol selected in <i>8-30 Protocol</i>
8-35 Minimum Response Delay	Specify a minimum delay time between receiving a request and transmitting a response. This function is for overcoming modem turnaround delays.
8-36 Maximum Response Delay	Specify a maximum delay time between transmitting a request and receiving a response.
8-37 Maximum Inter-char delay	If transmission is interrupted, specify a maximum delay time between two received bytes to ensure timeout.

Table 7.2 Modbus Communication Parameter Settings

7.1.5 EMC Precautions

To achieve interference-free operation of the RS-485 network, Danfoss recommends the following EMC precautions.

NOTICE!

Observe relevant national and local regulations, for example regarding protective ground connection. To avoid coupling of high-frequency noise between the cables, the RS-485 communication cable must be kept away from motor and brake resistor cables. Normally, a distance of 8 inches [200 mm] is sufficient, but Danfoss recommends keeping the greatest possible distance between the cables. Especially where cables run in parallel over long distances. When crossing is unavoidable, the RS-485 cable must cross motor and brake resistor cables at an angle of 90°.

7.2 Adjustable Frequency Protocol Overview

The FC protocol, also referred to as FC bus or Standard bus, is the Danfoss standard serial communication bus. It defines an access technique according to the master-follower principle for communications via a serial bus. One master and a maximum of 126 followers can be connected to the bus. The master selects the individual followers via an address character in the message. A follower itself can never transmit without first being requested to do so, and direct message transfer between the individual followers is not possible. Communications occur in half-duplex mode.

The master function cannot be transferred to another node (single-master system).

The physical layer is RS-485, thus utilizing the RS-485 port built into the adjustable frequency drive. The FC protocol supports different message formats:

- A short format of 8 bytes for process data.
- A long format of 16 bytes that also includes a parameter channel.
- A format used for texts.

7.2.1 FC with Modbus RTU

The FC protocol provides access to the control word and bus reference of the adjustable frequency drive.

The Control Word allows the Modbus master to control several important functions of the adjustable frequency drive.

- Start
- Stop of the adjustable frequency drive in various ways:
 - Coast stop
 - Quick stop
 - DC Brake stop
 - Normal (ramp) stop
- Reset after a fault trip
- Run at various preset speeds
- Run in reverse
- Change of the active set-up
- Control of the two relays built into the adjustable frequency drive

The bus reference is commonly used for speed control. It is also possible to access the parameters, read their values, and where possible, write values to them. This permits a range of control options, including controlling the setpoint of the adjustable frequency drive when its internal PI controller is used.

7.3 Network Configuration

7.3.1 Adjustable Frequency Drive Set-up

Set the following parameters to enable the FC protocol for the adjustable frequency drive.

Parameter	Setting
8-30 Protocol	FC
8-31 Address	1-126
8-32 Baud Rate	2,400-115,200
8-33 Parity / Stop Bits	Even parity, 1 stop bit (default)

Table 7.3

7.4 FC Protocol Message Framing Structure

7.4.1 Content of a Character (byte)

Each character transferred begins with a start bit. Then 8 data bits are transferred, corresponding to a byte. Each character is secured via a parity bit. This bit is set at "1" when it reaches parity. Parity is when there is an equal number of 1s in the 8 data bits and the parity bit in total. A stop bit completes a character, thus consisting of 11 bits in all.

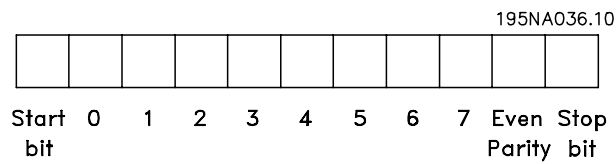

Figure 7.3 Content of a Character

7.4.2 Message Structure

Each message has the following structure:

1. Start character (STX)=02 Hex
2. A byte denoting the message length (LGE)
3. A byte denoting the adjustable frequency drive address (ADR)

A number of data bytes (variable, depending on the type of message) follows.

A data control byte (BCC) completes the message.



Figure 7.4

7.4.3 Message Length (LGE)

The message length is the number of data bytes plus the address byte ADR and the data control byte BCC.

4 data bytes	LGE=4+1+1=6 bytes
12 data bytes	LGE=12+1+1=14 bytes
Messages containing texts	10 ¹⁾ +n bytes

Table 7.4 Length of Messages

¹⁾ The 10 represents the fixed characters, while the "n" is variable (depending on the length of the text).

7.4.4 Adjustable Frequency Drive Address (ADR)

Address format 1-126

Bit 7=1 (address format 1-126 active)

Bit 0-6=adjustable frequency drive address 1-126

Bit 0-6=0 Broadcast

The follower returns the address byte unchanged to the master in the response message.

7.4.5 Data Control Byte (BCC)

The checksum is calculated as an XOR-function. Before the first byte in the message is received, the calculated checksum is 0.

7.4.6 The Data Field

The structure of data blocks depends on the type of message. There are three message types and the type applies for both control messages (master⇒follower) and response messages (follower⇒master).

The three types of message are:

Process block (PCD)

The PCD is made up of a data block of four bytes (two words) and contains:

- Control word and reference value (from master to follower)
- Status word and present output frequency (from follower to master)



130BA269.10

Figure 7.5 Process Block

Parameter block

The parameter block is used to transfer parameters between master and follower. The data block is made up of 12 bytes (6 words) and also contains the process block.

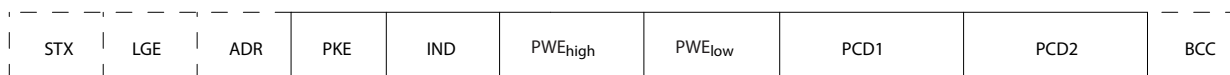

130BA271.10

Figure 7.6 Parameter Block

Text block

The text block is used to read or write texts via the data block.

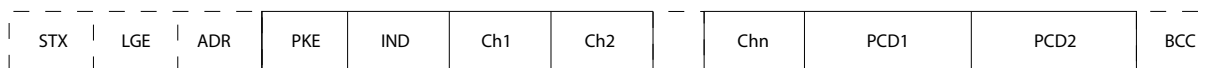

130BA270.10

Figure 7.7 Text Block

7.4.7 The PKE Field

The PKE field contains two subfields: Parameter command and response (AK) and Parameter number (PNU):

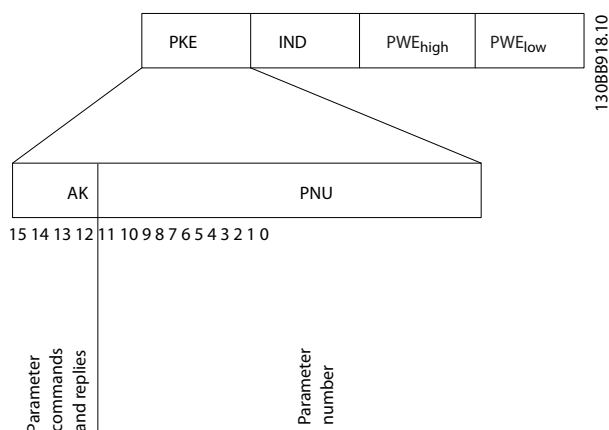

Figure 7.8 PKE Field

Bits no. 12-15 transfer parameter commands from master to follower and return processed follower responses to the master.

Parameter commands master ⇒ follower				
Bit no.				Parameter command
15	14	13	12	
0	0	0	0	No command
0	0	0	1	Read parameter value
0	0	1	0	Write parameter value in RAM (word)
0	0	1	1	Write parameter value in RAM (double word)
1	1	0	1	Write parameter value in RAM and EEPROM (double word)
1	1	1	0	Write parameter value in RAM and EEPROM (word)
1	1	1	1	Read text

Table 7.5 Parameter Commands

Response follower ⇒ master				
Bit no.				Response
15	14	13	12	
0	0	0	0	No response
0	0	0	1	Parameter value transferred (word)
0	0	1	0	Parameter value transferred (double word)
0	1	1	1	Command cannot be performed
1	1	1	1	text transferred

Table 7.6 Response

If the command cannot be performed, the follower sends this response:

0111 Command cannot be performed

- and issues the following fault report in the parameter value:

Error code	+ Specification
0	Illegal Parameter Number
1	Parameter cannot be changed.
2	Upper or lower limit exceeded
3	Subindex corrupted
4	No Array
5	Wrong Data Type
6	Not used
7	Not used
9	Description element not available
11	No parameter write access
15	No text available
17	Not while Running
18	Other error
100	
>100	
130	No bus access for this parameter
131	Write to factory set-up not possible
132	No LCP access
252	Unknown viewer
253	Request not supported
254	Unknown attribute
255	No error

Table 7.7 Follower Report

7.4.8 Parameter Number (PNU)

Bits no. 0-11 transfer parameter numbers. The function of the relevant parameter is defined in the parameter description in *chapter 6 How to Program*.

7.4.9 Index (IND)

The index is used with the parameter number to read/write-access parameters with an index, for example, *15-30 Alarm Log: Error Code*. The index consists of 2 bytes; a low byte, and a high byte.

Only the low byte is used as an index.

7.4.10 Parameter Value (PWE)

The parameter value block consists of two words (4 bytes), and the value depends on the defined command (AK). The master prompts for a parameter value when the PWE block contains no value. To change a parameter value (write), write the new value in the PWE block and send from the master to the follower.

When a follower responds to a parameter request (read command), the present parameter value in the PWE block is transferred and returned to the master. If a parameter contains several data options, e.g., *0-01 Language*, select the data value by entering the value in the PWE block. Serial communication is only capable of reading parameters containing data type 9 (text string).

15-40 FC Type to *15-53 Power Card Serial Number* contain data type 9.

For example, read the unit size and AC line voltage range in *15-40 FC Type*. When a text string is transferred (read), the length of the message is variable, and the texts are of different lengths. The message length is defined in the second byte of the message (LGE). When using text transfer, the index character indicates whether it is a read or a write command.

To read a text via the PWE block, set the parameter command (AK) to 'F' Hex. The index character high-byte must be "4".

7.4.11 Data Types Supported by the Adjustable Frequency Drive

Unsigned means that there is no operational sign in the message.

Data types	Description
3	Integer 16
4	Integer 32
5	Unsigned 8
6	Unsigned 16
7	Unsigned 32
9	Text string

Table 7.8 Data Types

7.4.12 Conversion

The various attributes of each parameter are displayed in the chapter *Parameter Lists* in the *Programming Guide*. Parameter values are transferred as whole numbers only. Conversion factors are therefore used to transfer decimals.

4-12 Motor Speed Low Limit [Hz] has a conversion factor of 0.1.

To preset the minimum frequency to 10 Hz, transfer the value 100. A conversion factor of 0.1 means that the value transferred is multiplied by 0.1. The value 100 is thus perceived as 10.0.

Conversion index	Conversion factor
74	0.1
2	100
1	10
0	1
-1	0.1
-2	0.01
-3	0.001
-4	0.0001
-5	0.00001

Table 7.9 Conversion

7.4.13 Process Words (PCD)

The block of process words is divided into two blocks of 16 bits, which always occur in the defined sequence.

PCD 1	PCD 2
Control message (master⇒ follower Control word)	Reference value
Control message (follower⇒ master) Status word	Present output frequency

Table 7.10 Process Words (PCD)

7.5 Examples

7.5.1 Writing a Parameter Value

Change *4-14 Motor Speed High Limit [Hz]* to 100 Hz. Write the data in EEPROM.

PKE=E19E Hex - Write single word in *4-14 Motor Speed High Limit [Hz]*:

IND=0000 Hex

PWEHIGH=0000 Hex

PWELOW=03E8 Hex

Data value 1000, corresponding to 100 Hz, see *chapter 7.4.12 Conversion*.

The message looks like this:

E19E	H	0000	H	0000	H	03E8	H
PKE		IND		PWE _{high}		PWE _{low}	

Figure 7.9 Message

130BA092.10

NOTICE!

4-14 Motor Speed High Limit [Hz] is a single word, and the parameter command for write in EEPROM is "E". Parameter 4-14 is 19E in hexadecimal.

The response from the follower to the master is:

119E	H	0000	H	0000	H	03E8	H
PKE		IND		PWE _{high}		PWE _{low}	

Figure 7.10 Response from Master

130BA093.10

7.5.2 Reading a Parameter Value

Read the value in *3-41 Ramp 1 Ramp Up Time*

PKE=1155 Hex - Read parameter value in *3-41 Ramp 1 Ramp Up Time*
 IND=0000 Hex
 PWE_{HIGH}=0000 Hex
 PWE_{LOW}=0000 Hex

1155	H	0000	H	0000	H	0000	H
PKE		IND		PWE _{high}		PWE _{low}	

Figure 7.11 Message

130BA094.10

If the value in *3-41 Ramp 1 Ramp Up Time* is 10 s, the response from the follower to the master is:

1155	H	0000	H	0000	H	03E8	H
PKE		IND		PWE _{high}		PWE _{low}	

Figure 7.12 Response

130BA267.10

3E8 Hex corresponds to 1000 decimal. The conversion index for *3-41 Ramp 1 Ramp Up Time* is -2, that is, 0.01. *3-41 Ramp 1 Ramp Up Time* is of the type *Unsigned 32*.

7.6 Modbus RTU Overview

7.6.1 Assumptions

Danfoss assumes that the installed controller supports the interfaces in this document, and strictly observes all requirements and limitations stipulated in the controller and adjustable frequency drive.

7.6.2 What the User Should Already Know

The Modbus RTU (Remote Terminal Unit) is designed to communicate with any controller that supports the interfaces defined in this document. It is assumed that the user has full knowledge of the capabilities and limitations of the controller.

7.6.3 Modbus RTU Overview

Regardless of the type of physical communication networks, the Modbus RTU Overview describes the process a controller uses to request access to another device. This process includes how the Modbus RTU responds to requests from another device, and how errors are detected and reported. It also establishes a common format for the layout and contents of message fields. During communications over a Modbus RTU network, the protocol determines:

- How each controller learns its device address
- Recognizes a message addressed to it
- Determines which actions to take
- Extracts any data or other information contained in the message

If a reply is required, the controller constructs the reply message and sends it.

Controllers communicate using a master-follower technique in which only the master can initiate transactions (called queries). Followers respond by supplying the requested data to the master, or by taking the action requested in the query.

The master can address individual followers, or can initiate a broadcast message to all followers. Followers return a response to queries that are addressed to them individually. No responses are returned to broadcast queries from the master. The Modbus RTU protocol establishes the format for the master's query by providing the device (or broadcast) address, a function code defining the requested action, any data to be sent, and an error-checking field. The follower's response message is also constructed using Modbus protocol. It contains fields confirming the action taken, any data to be returned and an error-checking field. If an error occurs in receipt of the message, or if the follower is unable to perform the requested action, the follower constructs an error message, and send it in response, or a timeout occurs.

7.6.4 Adjustable Frequency Drive with Modbus RTU

The adjustable frequency drive communicates in Modbus RTU format over the built-in RS-485 interface. Modbus RTU provides access to the control word and bus reference of the adjustable frequency drive.

The control word allows the Modbus master to control several important functions of the adjustable frequency drive:

- Start
- Stop of the adjustable frequency drive in various ways:
 - Coast stop
 - Quick stop
 - DC Brake stop
 - Normal (ramp) stop
- Reset after a fault trip
- Run at a variety of preset speeds
- Run in reverse
- Change the active set-up
- Control the adjustable frequency drive's built-in relay

The bus reference is commonly used for speed control. It is also possible to access the parameters, read their values, and where possible, write values to them. This permits a range of control options, including controlling the setpoint of the adjustable frequency drive when its internal PI controller is used.

7.7 Network Configuration

To enable Modbus RTU on the adjustable frequency drive, set the following parameters:

Parameter	Setting
8-30 Protocol	Modbus RTU
8-31 Address	1-247
8-32 Baud Rate	2400-115200
8-33 Parity / Stop Bits	Even parity, 1 stop bit (default)

Table 7.11 Network Configuration

7.8 Modbus RTU Message Framing Structure

7.8.1 Adjustable Frequency Drive with Modbus RTU

The controllers are set up to communicate on the Modbus network using RTU (Remote Terminal Unit) mode, with each byte in a message containing two 4-bit hexadecimal characters. The format for each byte is shown in *Table 7.12*.

Start bit	Data byte								Stop/parity	Stop

Table 7.12 Format for Each Byte

Coding System	8-bit binary, hexadecimal 0-9, A-F. 2 hexadecimal characters contained in each 8-bit field of the message
Bits Per Byte	1 start bit 8 data bits, least significant bit sent first 1 bit for even/odd parity; no bit for no parity 1 stop bit if parity is used; 2 bits if no parity
Error Check Field	Cyclical Redundancy Check (CRC)

7.8.2 Modbus RTU Message Structure

The transmitting device places a Modbus RTU message into a frame with a known beginning and ending point. This allows receiving devices to begin at the start of the message, read the address portion, determine which device is addressed (or all devices, if the message is broadcast), and to recognize when the message is completed. Partial messages are detected, and errors are set as a result. Characters for transmission must be in hexadecimal 00 to FF format in each field. The adjustable frequency drive continuously monitors the network bus, also during 'silent' intervals. When the first field (the address field) is received, each adjustable frequency drive or device decodes it to determine which device is being addressed. Modbus RTU messages addressed to zero are broadcast messages. No response is permitted for broadcast messages. A typical message frame is shown in *Table 7.13*.

Start	Address	Function	Data	CRC check	End
T1-T2-T3-T4	8 bits	8 bits	N x 8 bits	16 bits	T1-T2-T3-T4

Table 7.13 Typical Modbus RTU Message Structure

7.8.3 Start/Stop Field

Messages start with a silent period of at least 3.5 character intervals. This is implemented as a multiple of character intervals at the selected network baud rate (shown as Start T1-T2-T3-T4). The first field to be transmitted is the device address. Following the last transmitted character, a similar period of at least 3.5 character intervals marks the end of the message. A new message can begin after this period. The entire message frame must be transmitted as a continuous stream. If a silent period of more than 1.5 character intervals occurs before completion of the frame, the receiving device flushes the incomplete message and assumes that the next byte is the address field of a new message. Similarly, if a new message begins before 3.5 character intervals after a previous message, the receiving device considers it a continuation of the previous message. This causes a timeout (no response from the follower), since the value in the final CRC field is not valid for the combined messages.

7.8.4 Address Field

The address field of a message frame contains 8 bits. Valid follower device addresses are in the range of 0–247 decimal. The individual follower devices are assigned addresses in the range of 1–247. (0 is reserved for broadcast mode, which all followers recognize.) A master addresses a follower by placing the follower address in the address field of the message. When the follower sends its response, it places its own address in this address field to let the master know which follower is responding.

7.8.5 Function Field

The function field of a message frame contains 8 bits. Valid codes are in the range of 1-FF. Function fields are used to send messages between master and follower. When a message is sent from a master to a follower device, the function code field tells the follower what kind of action to perform. When the follower responds to the master, it uses the function code field to indicate either a normal (error-free) response, or that some kind of error occurred (called an exception response). For a normal response, the follower simply echoes the original function code. For an exception response, the follower returns a code that is equivalent to the original function code with its most significant bit set to logic 1. In addition, the follower places a unique code into the data field of the response message. This tells the master what kind of error occurred, or the reason for the exception. Also refer to *chapter 7.8.10 Function Codes Supported by Modbus RTU* and *chapter 7.8.11 Modbus Exception Codes*.

7.8.6 Data Field

The data field is constructed using sets of two hexadecimal digits, in the range of 00 to FF hexadecimal. These are made up of one RTU character. The data field of messages sent from a master to follower device contains additional information which the follower must use to take the action defined by the function code. This can include items such as coil or register addresses, the quantity of items to be handled and the count of actual data bytes in the field.

7.8.7 CRC Check Field

Messages include an error-checking field, operating based on a Cyclical Redundancy Check (CRC) method. The CRC field checks the contents of the entire message. It is applied regardless of any parity check method used for the individual characters of the message. The CRC value is calculated by the transmitting device, which appends the CRC as the last field in the message. The receiving device recalculates a CRC during receipt of the message and compares the calculated value to the actual value received in the CRC field. If the two values are unequal, a bus timeout results. The error-checking field contains a 16-bit binary value implemented as two 8-bit bytes. When this is done, the low-order byte of the field is appended first, followed by the high-order byte. The CRC high-order byte is the last byte sent in the message.

7.8.8 Coil Register Addressing

In Modbus, all data are organized in coils and holding registers. Coils hold a single bit, whereas holding registers hold a 2-byte word (that is 16 bits). All data addresses in Modbus messages are referenced to zero. The first occurrence of a data item is addressed as item number zero. For example: The coil known as 'coil 1' in a programmable controller is addressed as coil 0000 in the data address field of a Modbus message. Coil 127 decimal is addressed as coil 007EHEX (126 decimal). Holding register 40001 is addressed as register 0000 in the data address field of the message. The function code field already specifies a 'holding register' operation. Therefore, the '4XXXX' reference is implicit. Holding register 40108 is addressed as register 006BHEX (107 decimal).

Coil Number	Description	Signal Direction
1-16	Adjustable frequency drive control word (see <i>Table 7.15</i>)	Master to follower
17-32	Adjustable frequency drive speed or setpoint reference Range 0x0–0xFFFF (-200% ... -200%)	Master to follower
33-48	Adjustable frequency drive status word (see <i>Table 7.15</i> and <i>Table 7.16</i>)	Follower to master
49-64	Open-loop mode: Adjustable frequency drive output frequency Closed-loop mode: Adjustable frequency drive feedback signal	Follower to master
65	Parameter write control (master to follower)	
	0=	Parameter changes are written to the RAM of the adjustable frequency drive.
	1=	Parameter changes are written to the RAM and EEPROM of the adjustable frequency drive.
66-65536	Reserved	

Table 7.14 Coil Register

Coil	0	1
01	Preset reference LSB	
02	Preset reference MSB	
03	DC brake	No DC brake
04	Coast stop	No coast stop
05	Quick stop	No quick stop
06	Freeze freq.	No freeze freq.
07	Ramp stop	Start
08	No reset	Reset
09	No jog	Jog
10	Ramp 1	Ramp 2
11	Data not valid	Data valid
12	Relay 1 off	Relay 1 on
13	Relay 2 off	Relay 2 on
14	Set up LSB	
15		
16	No reversing	Reversing

Coil	0	1
33	Control not ready	Control ready
34	Adjustable frequency drive not ready	Adjustable frequency drive ready
35	Coasting stop	Safety closed
36	No alarm	Alarm
37	Not used	Not used
38	Not used	Not used
39	Not used	Not used
40	No warning	Warning
41	Not at reference	At reference
42	Hand mode	Auto mode
43	Out of freq. range	In frequency range
44	Stopped	Running
45	Not used	Not used
46	No voltage warning	Voltage warning
47	Not in current limit	Current limit
48	No thermal warning	Thermal warning

Table 7.15 Adjustable Frequency Drive Control Word (FC Profile)

Table 7.16 Adjustable Frequency Drive Status Word (FC Profile)

Bus address	Bus register ¹	PLC Register	Content	Access	Description
0	1	40001	Reserved		Reserved for Legacy Drives VLT 5000 and VLT 2800
1	2	40002	Reserved		Reserved for Legacy Drives VLT 5000 and VLT 2800
2	3	40003	Reserved		Reserved for Legacy Drives VLT 5000 and VLT 2800
3	4	40004	Free		
4	5	40005	Free		
5	6	40006	Modbus conf	Read/Write	TCP only. Reserved for Modbus TCP (p12-28 and 12-29 - store in EEPROM, etc.)
6	7	40007	Last error code	Read only	Error code received from parameter database, refer to WHAT 38295 for details
7	8	40008	Last error register	Read only	Address of register with which last error occurred, refer to WHAT 38296 for details
8	9	40009	Index pointer	Read/Write	Sub index of parameter to be accessed. Refer to WHAT 38297 for details
9	10	40010	FC par. 0-01	Dependent on parameter access	Parameter 0-01 (Modbus Register=10 parameter number 20 bytes space reserved pr parameter in Modbus Map
19	20	40020	FC par. 0-02	Dependent on parameter access	Parameter 0-02 20 bytes space reserved pr parameter in Modbus Map
29	30	40030	FC par. xx-xx	Dependent on parameter access	Parameter 0-03 20 bytes space reserved pr parameter in Modbus Map

Table 7.17 Adress/Registers

¹⁾ Value written in Modbus RTU message must be one, or less than register number, e.g., read Modbus Register 1 by writing value 0 in message.

7.8.9 How to Control the Adjustable Frequency Drive

This section describes codes which can be used in the function and data fields of a Modbus RTU message.

7.8.10 Function Codes Supported by Modbus RTU

Modbus RTU supports use of the following function codes in the function field of a message.

Function	Function Code
Read coils	1 hex
Read holding registers	3 hex
Write single coil	5 hex
Write single register	6 hex
Write multiple coils	F hex
Write multiple registers	10 hex
Get comm. event counter	B hex
Report follower ID	11 hex

Table 7.18 Function Codes

Function	Function Code	Sub-function code	Sub-function
Diagnostics	8	1	Restart communication
		2	Return diagnostic register
		10	Clear counters and diagnostic register
		11	Return bus message count
		12	Return bus communication error count
		13	Return bus exception error count
		14	Return follower message count

Table 7.19 Function Codes

7.8.11 Modbus Exception Codes

For a full explanation of the structure of an exception code response, refer to *chapter 7.8.5 Function Field*.

Code	Name	Meaning
1	Illegal function	The function code received in the query is not an allowable action for the server (or follower). This may be because the function code is only applicable to newer devices and was not implemented in the unit selected. It could also indicate that the server (or follower) is in the wrong state to process a request of this type, for example, because it is not configured and is being asked to return register values.
2	Illegal data address	The data address received in the query is not an allowable address for the server (or follower). More specifically, the combination of reference number and transfer length is invalid. For a controller with 100 registers, a request with offset 96 and length 4 would succeed, a request with offset 96 and length 5 generates exception 02.
3	Illegal data value	A value contained in the query data field is not an allowable value for server (or follower). This indicates a fault in the structure of the remainder of a complex request, such as that the implied length is incorrect. It specifically does NOT mean that a data item submitted for storage in a register has a value outside the expectation of the application program, since the Modbus protocol is unaware of the significance of any particular value of any particular register.
4	Follower device failure	An unrecoverable error occurred while the server (or follower) was attempting to perform the requested action.

Table 7.20 Modbus Exception Codes

7.9 How to Access Parameters

7.9.1 Parameter Handling

The PNU (Parameter Number) is translated from the register address contained in the Modbus read or write message. The parameter number is translated to Modbus as (10 x parameter number) DECIMAL. Example: Reading 3-12 *Catch up/slow-down value* (16 bit): The holding register 3120 holds the parameters value. A value of 1352 (Decimal) means that the parameter is set to 12.52%.

Reading 3-14 *Preset Relative Reference* (32 bit): The holding registers 3410 and 3411 hold the parameters value. A value of 11300 (decimal), means that the parameter is set to 1113.00 S.

For information on the parameters, size and converting index, consult the product relevant programming guide.

7.9.2 Storage of Data

The Coil 65 decimal determines whether data written to the adjustable frequency drive are stored in EEPROM and RAM (coil 65=1) or only in RAM (coil 65=0).

7.9.3 IND

Some parameters in the adjustable frequency drive are array parameters, e.g., 3-10 *Preset Reference*. Since the Modbus does not support arrays in the Holding registers, the adjustable frequency drive has reserved the Holding register 9 as pointer to the array. Before reading or writing an array parameter, set the holding register 9. Setting holding register to the value of 2, causes all following read/write to array parameters to be to the index 2.

7.9.4 Text Blocks

Parameters stored as text strings are accessed in the same way as the other parameters. The maximum text block size is 20 characters. If a read request for a parameter is for more characters than the parameter stores, the response is truncated. If the read request for a parameter is for fewer characters than the parameter stores, the response is padded with spaces.

7.9.5 Conversion Factor

The different attributes for each parameter can be seen in the section on factory settings. Since a parameter value can only be transferred as a whole number, a conversion factor must be used to transfer decimals.

7.9.6 Parameter Values

Standard data types

Standard data types are int16, int32, uint8, uint16 and uint32. They are stored as 4x registers (40001–4FFFF). The parameters are read using function 03HEX "Read Holding Registers." Parameters are written using the function 6HEX "Preset Single Register" for one register (16 bits), and the function 10 HEX "Preset Multiple Registers" for two registers (32 bits). Readable sizes range from one register (16 bits) up to ten registers (20 characters).

Non standard data types

Non-standard data types are text strings and are stored as 4x registers (40001–4FFFF). The parameters are read using function 03HEX "Read Holding Registers" and written using function 10HEX "Preset Multiple Registers." Readable sizes range from one register (two characters) up to ten registers (20 characters).

7.10 Examples

The following examples illustrate various Modbus RTU commands.

7.10.1 Read Coil Status (01 HEX)

Description

This function reads the ON/OFF status of discrete outputs (coils) in the adjustable frequency drive. Broadcast is never supported for reads.

Query

The query message specifies the starting coil and quantity of coils to be read. Coil addresses start at zero, that is, coil 33 is addressed as 32.

Example of a request to read coils 33–48 (Status Word) from follower device 01.

Field Name	Example (HEX)
Follower Address	01 (adjustable frequency drive address)
Function	01 (read coils)
Starting Address HI	00
Starting Address LO	20 (32 decimals) Coil 33
No. of Points HI	00
No. of Points LO	10 (16 decimals)
Error Check (CRC)	-

Table 7.21 Query

Response

The coil status in the response message is packed as one coil per bit of the data field. Status is indicated as: 1=ON; 0=OFF. The LSB of the first data byte contains the coil addressed in the query. The other coils follow toward the high order end of this byte and from 'low-order to high-order' in subsequent bytes.

If the returned coil quantity is not a multiple of 8, the remaining bits in the final data byte is padded with zeros (toward the high order end of the byte). The Byte Count field specifies the number of complete bytes of data.

Field Name	Example (HEX)
Follower Address	01 (adjustable frequency drive address)
Function	01 (read coils)
Byte Count	02 (2 bytes of data)
Data (Coils 40-33)	07
Data (Coils 48-41)	06 (STW=0607hex)
Error Check (CRC)	-

Table 7.22 Response

NOTICE!

Coils and registers are addressed explicit with an off-set of -1 in Modbus.

For example, Coil 33 is addressed as Coil 32.

7.10.2 Force/Write Single Coil (05 HEX)

Description

This function forces the coil to either ON or OFF. When broadcast the function forces the same coil references in all attached followers.

Query

The query message specifies the coil 65 (parameter write control) to be forced. Coil addresses start at zero, that is, coil 65 is addressed as 64. Force Data=00 00HEX (OFF) or FF 00HEX (ON).

Field Name	Example (HEX)
Follower Address	01 (adjustable frequency drive address)
Function	05 (write single coil)
Coil Address HI	00
Coil Address LO	40 (64 decimal) Coil 65
Force Data HI	FF
Force Data LO	00 (FF 00=ON)
Error Check (CRC)	-

Table 7.23 Query

Response

The normal response is an echo of the query, which is returned after the coil state has been forced.

Field Name	Example (HEX)
Follower Address	01
Function	05
Force Data HI	FF
Force Data LO	00
Quantity of Coils HI	00
Quantity of Coils LO	01
Error Check (CRC)	-

Table 7.24 Response

7.10.3 Force/Write Multiple Coils (0F HEX)

Description

This function forces each coil in a sequence of coils to either ON or OFF. When broadcasting the function forces the same coil references in all attached followers.

Query

The query message specifies the coils 17 to 32 (speed setpoint) to be forced.

Field Name	Example (HEX)
Follower Address	01 (adjustable frequency drive address)
Function	0F (write multiple coils)
Coil Address HI	00
Coil Address LO	10 (coil address 17)
Quantity of Coils HI	00
Quantity of Coils LO	10 (16 coils)
Byte Count	02
Force Data HI (Coils 8-1)	20
Force Data LO (Coils 16-9)	00 (ref.=2000 hex)
Error Check (CRC)	-

Table 7.25 Query

Response

The normal response returns the follower address, function code, starting address, and quantity of coils forced.

Field Name	Example (HEX)
Follower Address	01 (adjustable frequency drive address)
Function	0F (write multiple coils)
Coil Address HI	00
Coil Address LO	10 (coil address 17)
Quantity of Coils HI	00
Quantity of Coils LO	10 (16 coils)
Error Check (CRC)	-

Table 7.26 Response

7.10.4 Read Holding Registers (03 HEX)

Description

This function reads the contents of holding registers in the follower.

Query

The query message specifies the starting register and quantity of registers to be read. Register addresses start at zero, that is, registers 1-4 are addressed as 0-3.

Example: Read 3-03 *Maximum Reference*, register 03030.

Field Name	Example (HEX)
Follower Address	01
Function	03 (read holding registers)
Starting Address HI	0B (Register address 3029)
Starting Address LO	05 (Register address 3029)
No. of Points HI	00
No. of Points LO	02 - (3-03 <i>Maximum Reference</i> is 32 bits long, i.e., two registers)
Error Check (CRC)	-

Table 7.27 Query

Response

The register data in the response message are packed as two bytes per register, with the binary contents right justified within each byte. For each register, the first byte contains the high-order bits and the second contains the low-order bits.

Field Name	Example (HEX)
Follower Address	01
Function	03
Byte Count	04
Data HI (Register 3030)	00
Data LO (Register 3030)	16
Data HI (Register 3031)	E3
Data LO (Register 3031)	60
Error Check (CRC)	-

Table 7.28 Response

7.10.5 Preset Single Register (06 HEX)

Description

This function presets a value into a single holding register.

Query

The query message specifies the register reference to be preset. Register addresses start at zero, that is, register 1 is addressed as 0.

Example: Write to *1-00 Configuration Mode*, register 1000.

Field Name	Example (HEX)
Follower Address	01
Function	06
Register Address HI	03 (Register address 999)
Register Address LO	E7 (Register address 999)
Preset Data HI	00
Preset Data LO	01
Error Check (CRC)	-

Table 7.29 Query

Response

The normal response is an echo of the query, returned after the register contents have been passed.

Field Name	Example (HEX)
Follower Address	01
Function	06
Register Address HI	03
Register Address LO	E7
Preset Data HI	00
Preset Data LO	01
Error Check (CRC)	-

Table 7.30 Response

7.10.6 Preset Multiple Registers (10 HEX)

Description

This function presets values into a sequence of holding registers.

Query

The query message specifies the register references to be preset. Register addresses start at zero, that is, register 1 is addressed as 0. Example of a request to preset two registers (set *1-24 Motor Current* to 738 (7.38 A).

Field Name	Example (HEX)
Follower Address	01
Function	10
Starting Address HI	04
Starting Address LO	19
No. of Registers HI	00
No. of registers LO	02
Byte Count	04
Write Data HI (Register 4: 1049)	00
Write Data LO (Register 4: 1049)	00
Write Data HI (Register 4: 1050)	02
Write Data LO (Register 4: 1050)	E2
Error Check (CRC)	-

Table 7.31 Query

Response

The normal response returns the follower address, function code, starting address, and quantity of registers preset.

Field Name	Example (HEX)
Follower Address	01
Function	10
Starting Address HI	04
Starting Address LO	19
No. of Registers HI	00
No. of registers LO	02
Error Check (CRC)	-

Table 7.32 Response

7.11 Danfoss FC Control Profile

7.11.1 Control Word According to FC Profile (8-10 Protocol = FC profile)

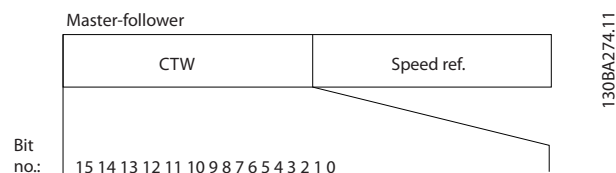

Figure 7.13 Control Word According to FC Profile

Bit	Bit value=0	Bit value=1
00	Reference value	external selection lsb
01	Reference value	external selection msb
02	DC brake	Ramp
03	Coasting	No coasting
04	Quick stop	Ramp
05	Hold output frequency	use ramp
06	Ramp stop	Start
07	No function	Reset
08	No function	Jog
09	Ramp 1	Ramp 2
10	Data invalid	Data valid
11	Relay 01 open	Relay 01 active
12	Relay 02 open	Relay 02 active
13	Parameter set-up	selection lsb
15	No function	Reverse

Table 7.33 Control Word According to FC Profile

Explanation of the control bits

Bits 00/01

Bits 00 and 01 are used to select between the four reference values, which are pre-programmed in 3-10 *Preset Reference* according to the Table 7.34.

Programmed ref. value	Parameter	Bit 01	Bit 00
1	3-10 <i>Preset Reference</i> [0]	0	0
2	3-10 <i>Preset Reference</i> [1]	0	1
3	3-10 <i>Preset Reference</i> [2]	1	0
4	3-10 <i>Preset Reference</i> [3]	1	1

Table 7.34 Control Bits

NOTICE!

Make a selection in 8-56 *Preset Reference Select* to define how Bit 00/01 gates with the corresponding function on the digital inputs.

Bit 02, DC brake

Bit 02='0' leads to DC braking and stop. Set braking current and duration in 2-01 *DC Brake Current* and 2-02 *DC Braking Time*.

Bit 02='1' leads to ramping.

Bit 03, Coasting

Bit 03='0': The adjustable frequency drive immediately "lets go" of the motor (the output transistors are "shut off"), and it coasts to a standstill.

Bit 03='1': The adjustable frequency drive starts the motor if the other starting conditions are met.

Make a selection in 8-50 *Coasting Select* to define how Bit 03 gates with the corresponding function on a digital input.

Bit 04, Quick stop

Bit 04='0': Makes the motor speed ramp down to stop (set in 3-81 *Quick Stop Ramp Time*).

Bit 05, Hold output frequency

Bit 05='0': The present output frequency (in Hz) freezes. Change the frozen output frequency only with the digital inputs (5-10 *Terminal 18 Digital Input* to 5-13 *Terminal 29 Digital Input*) programmed to *Speed up*=21 and *Slow-down*=22.

NOTICE!

If Freeze output is active, the adjustable frequency drive can only be stopped by the following:

- Bit 03 Coasting stop
- Bit 02 DC braking
- Digital input (5-10 *Terminal 18 Digital Input* to 5-13 *Terminal 29 Digital Input*) programmed to *DC braking*=5, *Coasting stop*=2, or *Reset and coasting stop*=3.

Bit 06, Ramp stop/start

Bit 06='0': Causes a stop and makes the motor speed ramp down to stop via the selected ramp-down parameter. Bit 06='1': Permits the adjustable frequency drive to start the motor if the other starting conditions are met.

Make a selection in 8-53 *Start Select* to define how Bit 06 Ramp stop/start gates with the corresponding function on a digital input.

Bit 07, Reset

Bit 07='0': No reset.

Bit 07='1': Resets a trip. Reset is activated on the signal's leading edge, that is, when changing from logic '0' to logic '1'.

Bit 08, Jog

Bit 08='1': The output frequency is determined by 3-11 *Jog Speed [Hz]*.

Bit 09, Selection of ramp 1/2

Bit 09="0": Ramp 1 is active (3-41 Ramp 1 Ramp Up Time to 3-42 Ramp 1 Ramp Down Time).

Bit 09="1": Ramp 2 (3-51 Ramp 2 Ramp Up Time to 3-52 Ramp 2 Ramp Down Time) is active.

Bit 10, Data not valid/Data valid

Tell the adjustable frequency drive whether to use or ignore the control word.

Bit 10="0": The control word is ignored.

Bit 10="1": The control word is used. This function is relevant because the message always contains the control word, regardless of the message type. Turn off the control word if not wanting to use it when updating or reading parameters.

Bit 11, Relay 01

Bit 11="0": Relay not activated.

Bit 11="1": Relay 01 activated provided that Control word bit 11=36 is chosen in 5-40 Function Relay.

Bit 12, Relay 02

Bit 12="0": Relay 02 is not activated.

Bit 12="1": Relay 02 is activated provided that Control word bit 12=37 is chosen in 5-40 Function Relay.

Bit 13, Selection of set-up

Use bit 13 to select from the two menu set-ups according to Table 7.35.

Set-up	Bit 13
1	0
2	1

The function is only possible when Multi Set-ups=9 is selected in 0-10 Active Set-up.

Make a selection in 8-55 Set-up Select to define how Bit 13 gates with the corresponding function on the digital inputs.

Bit 15 Reverse

Bit 15="0": No reversing.

Bit 15="1": Reversing. In the default setting, reversing is set to digital in 8-54 Reversing Select. Bit 15 causes reversing only when Serial communication, Logic or Logic and is selected.

7.11.2 Status Word According to FC Profile (STW) (8-30 Protocol = FC profile)

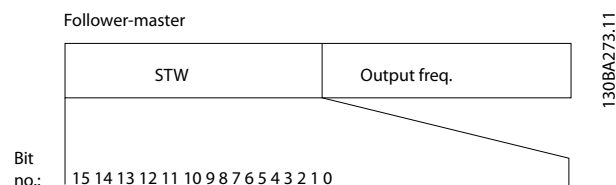

Figure 7.14 Status Word

Bit	Bit=0	Bit=1
00	Control not ready	Control ready
01	Drive not ready	Drive ready
02	Coasting	Enable
03	No error	Trip
04	No error	Error (no trip)
05	Reserved	-
06	No error	Triplock
07	No warning	Warning
08	Speed ≠ reference	Speed=reference
09	Local operation	Bus control
10	Out of frequency limit	Frequency limit OK
11	No operation	In operation
12	Drive OK	Stopped, auto start
13	Voltage OK	Voltage exceeded
14	Torque OK	Torque exceeded
15	Timer OK	Timer exceeded

Table 7.35 Status Word According to FC Profile

Explanation of the status bits

Bit 00, Control not ready/ready

Bit 00="0": The adjustable frequency drive trips.

Bit 00="1": The adjustable frequency drive controls are ready, but the power component does not necessarily receive any power supply (in case of external 24 V supply to controls).

Bit 01, Drive ready

Bit 01="0": The adjustable frequency drive is not ready.

Bit 01="1": The adjustable frequency drive is ready for operation but the coasting command is active via the digital inputs or via serial communication.

Bit 02, Coasting stop

Bit 02="0": The adjustable frequency drive releases the motor.

Bit 02="1": The adjustable frequency drive starts the motor with a start command.

Bit 03, No error/trip

Bit 03='0': The adjustable frequency drive is not in fault mode. Bit 03='1': The adjustable frequency drive trips. To re-establish operation, press [Reset].

Bit 04, No error/error (no trip)

Bit 04='0': The adjustable frequency drive is not in fault mode. Bit 04='1': The adjustable frequency drive shows an error but does not trip.

Bit 05, Not used

Bit 05 is not used in the status word.

Bit 06, No error / tripllock

Bit 06='0': The adjustable frequency drive is not in fault mode. Bit 06='1': The adjustable frequency drive is tripped and locked.

Bit 07, No warning/warning

Bit 07='0': There are no warnings. Bit 07='1': A warning has occurred.

Bit 08, Speed# reference/speed=reference

Bit 08='0': The motor is running but the present speed is different from the preset speed reference. It might, for example, be the case when the speed ramps up/down during start/stop.

Bit 08='1': The motor speed matches the preset speed reference.

Bit 09, Local operation/bus control

Bit 09='0': [Off/Reset] is activated on the control unit or *Local control* in 3-13 Reference Site is selected. It is not possible to control the adjustable frequency drive via serial communication.

Bit 09='1' It is possible to control the adjustable frequency drive via the serial communication bus/serial communication.

Bit 10, Out of frequency limit

Bit 10='0': The output frequency has reached the value in 4-12 *Motor Speed Low Limit [Hz]* or 4-14 *Motor Speed High Limit [Hz]*.

Bit 10='1': The output frequency is within the defined limits.

Bit 11, No operation/in operation

Bit 11='0': The motor is not running.

Bit 11='1': The coasting has a start signal or the output frequency is greater than 0 Hz.

Bit 12, Drive OK/stopped, autostart

Bit 12='0': There is no temporary overtemperature on the inverter.

Bit 12='1': The inverter stops because of overtemperature but the unit does not trip and resumes operation once the overtemperature stops.

Bit 13, Voltage OK/limit exceeded

Bit 13='0': There are no voltage warnings.

Bit 13='1': The DC voltage in the intermediate circuit of the adjustable frequency drive is too low or too high.

Bit 14, Torque OK/limit exceeded

Bit 14='0': The motor current is lower than the torque limit selected in 4-18 *Current Limit*.

Bit 14='1': The torque limit in 4-18 *Current Limit* is exceeded.

Bit 15, Timer OK/limit exceeded

Bit 15='0': The timers for motor thermal protection and thermal protection are not exceeded 100%.

Bit 15='1': One of the timers exceeds 100%.

7.11.3 Bus Speed Reference Value

Speed reference value is transmitted to the adjustable frequency drive in a relative value expressed as %. The value is transmitted in the form of a 16-bit word; in integers (0–32767) the value 16384 (4000 Hex) corresponds to 100%. Negative figures are formatted by means of 2's complement. The Actual Output frequency (MAV) is scaled in the same way as the bus reference.

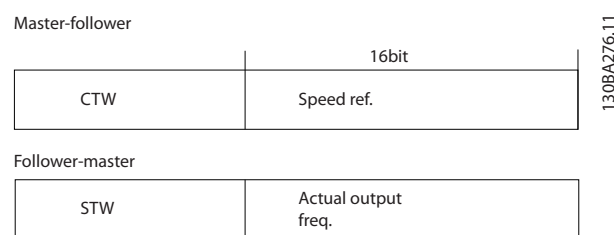

Figure 7.15 Actual Output Frequency (MAV)

The reference and MAV are scaled as follows:

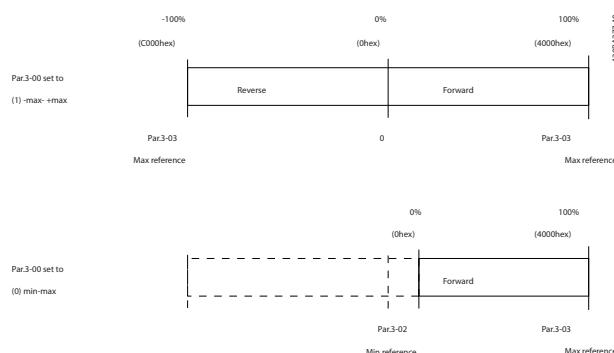

Figure 7.16 Reference and MAV

8 General Specifications and Troubleshooting

8.1 Line Power Supply Specifications

8.1.1 Line Power Supply 3x200–240 V AC

Adjustable frequency drive	PK25	PK37	PK75	P1K5	P2K2	P3K7	P5K5	P7K5	P11K	P15K	P18K	P22K	P30K	P37K	P45K
Typical shaft output [kW]	0.25	0.37	0.75	1.5	2.2	3.7	5.5	7.5	11.0	15.0	18.5	22.0	30.0	37.0	45.0
Typical shaft output [hp]	0.33	0.5	1.0	2.0	3.0	5.0	7.5	10.0	15.0	20.0	25.0	30.0	40.0	50.0	60.0
IP20 frame	H1	H1	H1	H1	H2	H3	H4	H4	H5	H6	H6	H7	H7	H8	H8
Max. cable size in terminals (line power, motor) [mm ² /AWG]	4/10	4/10	4/10	4/10	4/10	4/10	16/6	16/6	16/6	35/2	35/2	50/1	50/1	95/0	120/(4/0)
Output current															
104 °F [40 °C] ambient temperature															
Continuous (3x200–240 V) [A]	1.5	2.2	4.2	6.8	9.6	15.2	22.0	28.0	42.0	59.4	74.8	88.0	115.0	143.0	170.0
Intermittent (3x200–240 V) [A]	1.7	2.4	4.6	7.5	10.6	16.7	24.2	30.8	46.2	65.3	82.3	96.8	126.5	157.3	187.0
Max. input current															
Continuous 3x200–240 V [A]	1.1	1.6	2.8	5.6	8.6/7.2	14.1/12.0	21.0/18.0	28.3/24.0	41.0/38.2	52.7	65.0	76.0	103.7	127.9	153.0
Intermittent (3x200–240 V) [A]	1.2	1.8	3.1	6.2	9.5/7.9	15.5/13.2	23.1/19.8	31.1/26.4	45.1/42.0	58.0	71.5	83.7	114.1	140.7	168.3
Max. electrical fuses	See chapter 5.2.3 Fuses and Circuit Breakers														
Estimated power loss [W], Best case/typical ¹⁾	12/14	15/18	21/26	48/60	80/102	97/120	182/204	229/268	369/386	512	697	879	1149	1390	1500
Weight enclosure IP20 lb [kg]	4.41 [2.0]	4.41 [2.0]	4.41 [2.0]	4.63 [2.1]	7.5 [3.4]	9.92 [4.5]	17.42 [7.9]	17.42 [7.9]	20.94 [9.5]	54.01 [24.5]	54.01 [24.5]	79.37 [36.0]	79.37 [36.0]	112.44 [51.0]	112.44 [51.0]
Efficiency [%], best case/typical ¹⁾	97.0/96.5	97.3/96.8	98.0/97.6	97.6/97.0	97.1/96.3	97.9/97.4	97.3/97.0	98.5/97.1	97.2/97.1	97.0	97.1	96.8	97.1	97.1	97.3
Output current															
122 °F [50 °C] ambient temperature															
Continuous (3x200–240 V) [A]	1.5	1.9	3.5	6.8	9.6	13.0	19.8	23.0	33.0	41.6	52.4	61.6	80.5	100.1	119
Intermittent (3x200–240 V) [A]	1.7	2.1	3.9	7.5	10.6	14.3	21.8	25.3	36.3	45.8	57.6	67.8	88.6	110.1	130.9

Table 8.1 3x200–240 V AC, PK25–P45K

¹⁾ At rated load conditions

8.1.2 Line Power Supply 3x380–480 V AC

Adjustable frequency drive	PK37	PK75	P1K5	P2K2	P3K0	P4K0	P5K5	P7K5	P11K	P15K
Typical shaft output [kW]	0.37	0.75	1.5	2.2	3.0	4.0	5.5	7.5	11.0	15.0
Typical shaft output [hp]	0.5	1.0	2.0	3.0	4.0	5.0	7.5	10.0	15.0	20.0
IP20 frame	H1	H1	H1	H2	H2	H2	H3	H3	H4	H4
Max. cable size in terminals (line power, motor) [mm ² /AWG]	4/10	4/10	4/10	4/10	4/10	4/10	4/10	4/10	16/6	16/6
Output current - 104 °F [40 °C] ambient temperature										
Continuous (3x380–440 V) [A]	1.2	2.2	3.7	5.3	7.2	9.0	12.0	15.5	23.0	31.0
Intermittent (3x380–440 V) [A]	1.3	2.4	4.1	5.8	7.9	9.9	13.2	17.1	25.3	34.0
Continuous (3x440–480 V) [A]	1.1	2.1	3.4	4.8	6.3	8.2	11.0	14.0	21.0	27.0
Intermittent (3x440–480 V) [A]	1.2	2.3	3.7	5.3	6.9	9.0	12.1	15.4	23.1	29.7
Max. input current										
Continuous (3x380–440 V) [A]	1.2	2.1	3.5	4.7	6.3	8.3	11.2	15.1	22.1	29.9
Intermittent (3x380–440 V) [A]	1.3	2.3	3.9	5.2	6.9	9.1	12.3	16.6	24.3	32.9
Continuous (3x440–480 V) [A]	1.0	1.8	2.9	3.9	5.3	6.8	9.4	12.6	18.4	24.7
Intermittent (3x440–480 V) [A]	1.1	2.0	3.2	4.3	5.8	7.5	10.3	13.9	20.2	27.2
Max. electrical fuses	See chapter 5.2.3 Fuses and Circuit Breakers									
Estimated power loss [W], best case/typical ¹⁾	13/15	16/21	46/57	46/58	66/83	95/118	104/131	159/198	248/274	353/379
Weight enclosure IP20 lb [kg]	4.41 [2.0]	4.41 [2.0]	4.63 [2.1]	7.28 [3.3]	7.28 [3.3]	7.5 [3.4]	9.48 [4.3]	9.92 [4.5]	17.42 [7.9]	17.42 [7.9]
Efficiency [%], best case/typical ¹⁾	97.8/ 97.3	98.0/ 97.6	97.7/ 97.2	98.3/ 97.9	98.2/ 97.8	98.0/ 97.6	98.4/ 98.0	98.2/ 97.8	98.1/ 97.9	98.0/ 97.8
Output current - 122 °F [50 °C] ambient temperature										
Continuous (3x380–440 V) [A]	1.04	1.93	3.7	4.85	6.3	8.4	10.9	14.0	20.9	28.0
Intermittent (3x380–440 V) [A]	1.1	2.1	4.07	5.4	6.9	9.2	12.0	15.4	23.0	30.8
Continuous (3x440–480 V) [A]	1.0	1.8	3.4	4.4	5.5	7.5	10.0	12.6	19.1	24.0
Intermittent (3x440–480 V) [A]	1.1	2.0	3.7	4.8	6.1	8.3	11.0	13.9	21.0	26.4

Table 8.2 3x380–480 V AC, PK37–P11K, H1–H4

1) At rated load conditions

Adjustable frequency drive	P18K	P22K	P30K	P37K	P45K	P55K	P75K	P90K
Typical shaft output [kW]	18.5	22.0	30.0	37.0	45.0	55.0	75.0	90.0
Typical shaft output [hp]	25.0	30.0	40.0	50.0	60.0	70.0	100.0	125.0
IP20 frame	H5	H5	H6	H6	H6	H7	H7	H8
Max. cable size in terminals (line power, motor) [mm ² /AWG]	16/6	16/6	35/2	35/2	35/2	50/1	95/0	120/250 MCM
Output current - 104 °F [40 °C] ambient temperature								
Continuous (3x380–440 V) [A]	37.0	42.5	61.0	73.0	90.0	106.0	147.0	177.0
Intermittent (3x380–440 V) [A]	40.7	46.8	67.1	80.3	99.0	116.0	161.0	194.0
Continuous (3x440–480 V) [A]	34.0	40.0	52.0	65.0	80.0	105.0	130.0	160.0
Intermittent (3x440–480 V) [A]	37.4	44.0	57.2	71.5	88.0	115.0	143.0	176.0
Max. input current								
Continuous (3x380–440 V) [A]	35.2	41.5	57.0	70.0	84.0	103.0	140.0	166.0
Intermittent (3x380–440 V) [A]	38.7	45.7	62.7	77.0	92.4	113.0	154.0	182.0
Continuous (3x440–480 V) [A]	29.3	34.6	49.2	60.6	72.5	88.6	120.9	142.7
Intermittent (3x440–480 V) [A]	32.2	38.1	54.1	66.7	79.8	97.5	132.9	157.0
Max. electrical fuses								
Estimated power loss [W], best case/typical ¹⁾	412/456	475/523	733	922	1067	1133	1733	2141
Weight enclosure IP20 lb [kg]	20.94 [9.5]	20.94 [9.5]	54.01 [24.5]	54.01 [24.5]	54.01 [24.5]	79.37 [36.0]	79.37 [36.0]	112.44 [51.0]
Efficiency [%], best case/typical ¹⁾	98.1/97.9	98.1/97.9	97.8	97.7	98	98.2	97.8	97.9
Output current - 122 °F [50 °C] ambient temperature								
Continuous (3x380–440 V) [A]	34.1	38.0	48.8	58.4	72.0	74.2	102.9	123.9
Intermittent (3x380–440 V) [A]	37.5	41.8	53.7	64.2	79.2	81.6	113.2	136.3
Continuous (3x440–480 V) [A]	31.3	35.0	41.6	52.0	64.0	73.5	91.0	112.0
Intermittent (3x440–480 V) [A]	34.4	38.5	45.8	57.2	70.4	80.9	100.1	123.2

Table 8.3 3x380–480 V AC, P18K–P90K, H5–H8

1) At rated load conditions

Adjustable frequency drive	PK75	P1K5	P2K2	P3K0	P4K0	P5K5	P7K5	P11K	P15K	P18K
Typical shaft output [kW]	0.75	1.5	2.2	3.0	4.0	5.5	7.5	11	15	18.5
Typical shaft output [hp]	1.0	2.0	3.0	4.0	5.0	7.5	10.0	15	20	25
IP54 frame	I2	I2	I2	I2	I2	I3	I3	I4	I4	I4
Max. cable size in terminals (line power, motor) [mm ² /AWG]	4/10	4/10	4/10	4/10	4/10	4/10	4/10	16/6	16/6	16/6
Output current										
104 °F [40 °C] ambient temperature										
Continuous (3x380–440 V) [A]	2.2	3.7	5.3	7.2	9.0	12.0	15.5	23.0	31.0	37.0
Intermittent (3x380–440 V) [A]	2.4	4.1	5.8	7.9	9.9	13.2	17.1	25.3	34.0	40.7
Continuous (3x440–480 V) [A]	2.1	3.4	4.8	6.3	8.2	11.0	14.0	21.0	27.0	34.0
Intermittent (3x440–480 V) [A]	2.3	3.7	5.3	6.9	9.0	12.1	15.4	23.1	29.7	37.4
Max. input current										
Continuous (3x380–440 V) [A]	2.1	3.5	4.7	6.3	8.3	11.2	15.1	22.1	29.9	35.2
Intermittent (3x380–440 V) [A]	2.3	3.9	5.2	6.9	9.1	12.3	16.6	24.3	32.9	38.7
Continuous (3x440–480 V) [A]	1.8	2.9	3.9	5.3	6.8	9.4	12.6	18.4	24.7	29.3
Intermittent (3 x 440–480 V) [A]	2.0	3.2	4.3	5.8	7.5	10.3	13.9	20.2	27.2	32.2
Max. electrical fuses	See chapter 5.2.3 Fuses and Circuit Breakers									
Estimated power loss [W], best case/typical ¹⁾	21/ 16	46/ 57	46/ 58	66/ 83	95/ 118	104/ 131	159/ 198	248/ 274	353/ 379	412/ 456
Weight enclosure IP54 [kg]	0.21 [5.3]	0.21 [5.3]	0.21 [5.3]	0.21 [5.3]	0.21 [5.3]	15.87 [7.2]	15.87 [7.2]	30.42 [13.8]	30.42 [13.8]	30.42 [13.8]
Efficiency [%], best case/typical ¹⁾	98.0/ 97.6	97.7/ 97.2	98.3/ 97.9	98.2/ 97.8	98.0/ 97.6	98.4/ 98.0	98.2/ 97.8	98.1/ 97.9	98.0/ 97.8	98.1/ 97.9
Output current - 122 °F [50 °C] ambient temperature										
Continuous (3x380–440 V) [A]	1.93	3.7	4.85	6.3	7.5	10.9	14.0	20.9	28.0	33.0
Intermittent (3x380–440 V) [A]	2.1	4.07	5.4	6.9	9.2	12.0	15.4	23.0	30.8	36.3
Continuous (3x440–480 V) [A]	1.8	3.4	4.4	5.5	6.8	10.0	12.6	19.1	24.0	30.0
Intermittent (3x440–480 V) [A]	2.0	3.7	4.8	6.1	8.3	11.0	13.9	21.0	26.4	33.0

Table 8.4 3x380–480 V AC, PK75–P18K, I2–I4

1) At rated load conditions

Adjustable frequency drive	P22K	P30K	P37K	P45K	P55K	P75K	P90K
Typical shaft output [kW]	22.0	30.0	37.0	45.0	55.0	75.0	90.0
Typical shaft output [hp]	30.0	40.0	50.0	60.0	70.0	100.0	125.0
IP54 frame	I6	I6	I6	I7	I7	I8	I8
Max. cable size in terminals (line power, motor) [mm ² /AWG]	35/2	35/2	35/2	50/1	50/1	95/(3/0)	120/(4/0)
Output current							
104 °F [40 °C] ambient temperature							
Continuous (3x380–440 V) [A]	44.0	61.0	73.0	90.0	106.0	147.0	177.0
Intermittent (3x380–440 V) [A]	48.4	67.1	80.3	99.0	116.6	161.7	194.7
Continuous (3x440–480 V) [A]	40.0	52.0	65.0	80.0	105.0	130.0	160.0
Intermittent (3x440–480 V) [A]	44.0	57.2	71.5	88.0	115.5	143.0	176.0
Max. input current							
Continuous (3x380–440 V) [A]	41.8	57.0	70.3	84.2	102.9	140.3	165.6
Intermittent (3x380–440 V) [A]	46.0	62.7	77.4	92.6	113.1	154.3	182.2
Continuous (3x440–480 V) [A]	36.0	49.2	60.6	72.5	88.6	120.9	142.7
Intermittent (3 x 440–480 V) [A]	39.6	54.1	66.7	79.8	97.5	132.9	157.0
Max. electrical fuses							
Estimated power loss [W], best case/typical ¹⁾	496	734	995	840	1099	1520	1781
Weight enclosure IP54 [kg]	59.53 [27]	59.53 [27]	59.53 [27]	99.21 [45]	99.21 [45]	143.3 [65]	143.3 [65]
Efficiency [%], best case/Typical ¹⁾	98.0	97.8	97.6	98.3	98.2	98.1	98.3
Output current - 122 °F [50 °C] ambient temperature							
Continuous (3x380–440 V) [A]	35.2	48.8	58.4	63.0	74.2	102.9	123.9
Intermittent (3x380–440 V) [A]	38.7	53.9	64.2	69.3	81.6	113.2	136.3
Continuous (3x440–480 V) [A]	32.0	41.6	52.0	56.0	73.5	91.0	112.0
Intermittent (3x440–480 V) [A]	35.2	45.8	57.2	61.6	80.9	100.1	123.2

Table 8.5 3x380–480 V AC, P11K–P90K, I6–I8

1) At rated load conditions

8.1.3 Line Power Supply 3x380–480 V AC

Adjustable frequency drive	PK75	P1K5	P2K2	P3K0	P4K0	P5K5	P7K5	P11K	P15K
Typical shaft output [kW]	0.75	1.5	2.2	3.0	4.0	5.5	7.5	11	15
Typical shaft output [hp]	1.0	2.0	3.0	4.0	5.0	7.5	10.0	15	20
IP54 frame	I2	I2	I2	I2	I2	I3	I3	I4	I4
Max. cable size in terminals (line power, motor) [mm ² /AWG]	4/10	4/10	4/10	4/10	4/10	4/10	4/10	16/6	16/6
Output current									
104 °F [40 °C] ambient temperature									
Continuous (3x380–440 V) [A]	2.2	3.7	5.3	7.2	9.0	12.0	15.5	23.0	31.0
Intermittent (3x380–440 V) [A]	2.4	4.1	5.8	7.9	9.9	13.2	17.1	25.3	34.0
Continuous (3x440–480 V) [A]	2.1	3.4	4.8	6.3	8.2	11.0	14.0	21.0	27.0
Intermittent (3x440–480 V) [A]	2.3	3.7	5.3	6.9	9.0	12.1	15.4	23.1	29.7
Max. input current									
Continuous (3x380–440 V) [A]	2.1	3.5	4.7	6.3	8.3	11.2	15.1	22.1	29.9
Intermittent (3x380–440 V) [A]	2.3	3.9	5.2	6.9	9.1	12.3	16.6	24.3	32.9
Continuous (3x440–480 V) [A]	1.8	2.9	3.9	5.3	6.8	9.4	12.6	18.4	24.7
Intermittent (3 x 440–480 V) [A]	2.0	3.2	4.3	5.8	7.5	10.3	13.9	20.2	27.2
Max. electrical fuses	See chapter 5.2.3 Fuses and Circuit Breakers								
Estimated power loss [W, Best case/typical ¹⁾]	21/ 16	46/ 57	46/ 58	66/ 83	95/ 118	104/ 131	159/ 198	248/ 274	353/ 379
Weight enclosure IP54 [kg]	0.21 [5.3]	0.21 [5.3]	0.21 [5.3]	0.21 [5.3]	0.21 [5.3]	15.87 [7.2]	15.87 [7.2]	30.42 [13.8]	30.42 [13.8]
Efficiency [%], Best case/Typical ¹⁾	98.0/ 97.6	97.7/ 97.2	98.3/ 97.9	98.2/ 97.8	98.0/ 97.6	98.4/ 98.0	98.2/ 97.8	98.1/ 97.9	98.0/ 97.8
Output current									
122 °F [50 °C] ambient temperature									
Continuous (3x380–440 V) [A]	1.93	3.7	4.85	6.3	7.5	10.9	14.0	20.9	28.0
Intermittent (3x380–440 V) [A]	2.1	4.07	5.4	6.9	9.2	12.0	15.4	23.0	30.8
Continuous (3x440–480 V) [A]	1.8	3.4	4.4	5.5	6.8	10.0	12.6	19.1	24.0
Intermittent (3x440–480 V) [A]	2.0	3.7	4.8	6.1	8.3	11.0	13.9	21.0	26.4

Table 8.6 PK75–P15K

1) At rated load conditions

Adjustable frequency drive	P18K	P22K	P30K	P37K	P45K	P55K	P75K	P90K
Typical shaft output [kW]	18.5	22.0	30.0	37.0	45.0	55.0	75.0	90.0
Typical shaft output [hp]	25	30.0	40.0	50.0	60.0	70.0	100.0	125.0
IP54 frame	I4	I6	I6	I6	I7	I7	I8	I8
Max. cable size in terminals (line power, motor) [mm ² /AWG]	16/6	35/2	35/2	35/2	50/1	50/1	95/(3/0)	120/(4/0)
Output current								
104 °F [40 °C] ambient temperature								
Continuous (3x380–440 V) [A]	37.0	44.0	61.0	73.0	90.0	106.0	147.0	177.0
Intermittent (3x380–440 V) [A]	40.7	48.4	67.1	80.3	99.0	116.6	161.7	194.7
Continuous (3x440–480 V) [A]	34.0	40.0	52.0	65.0	80.0	105.0	130.0	160.0
Intermittent (3x440–480 V) [A]	37.4	44.0	57.2	71.5	88.0	115.5	143.0	176.0
Max. input current								
Continuous (3x380–440 V) [A]	35.2	41.8	57.0	70.3	84.2	102.9	140.3	165.6
Intermittent (3x380–440 V) [A]	38.7	46.0	62.7	77.4	92.6	113.1	154.3	182.2
Continuous (3x440–480 V) [A]	29.3	36.0	49.2	60.6	72.5	88.6	120.9	142.7
Intermittent (3 x 440–480 V) [A]	32.2	39.6	54.1	66.7	79.8	97.5	132.9	157.0
Max. electrical fuses								
Estimated power loss [W], Best case/typical ¹⁾	412/ 456	496	734	995	840	1099	1520	1781
Weight enclosure IP54 [kg]	13.8	27	27	27	45	45	65	65
Efficiency [%], Best case/Typical ¹⁾	98.1/ 97.9	98.0	97.8	97.6	98.3	98.2	98.1	98.3
Output current								
122 °F [50 °C] ambient temperature								
Continuous (3x380–440 V) [A]	33.0	35.2	48.8	58.4	63.0	74.2	102.9	123.9
Intermittent (3x380–440 V) [A]	36.3	38.7	53.9	64.2	69.3	81.6	113.2	136.3
Continuous (3x440–480 V) [A]	30.0	32.0	41.6	52.0	56.0	73.5	91.0	112.0
Intermittent (3x440–480 V) [A]	33.0	35.2	45.8	57.2	61.6	80.9	100.1	123.2

Table 8.7 P18K–P90K

1) At rated load conditions

8.1.4 Line Power Supply 3x525–600 V AC

Adjustable frequency drive	P2K2	P3K0	P3K7	P5K5	P7K5	P11K	P15K	P18K	P22K	P30K	P37K	P45K	P55K	P75K	P90K
Typical shaft output [kW]	2.2	3.0	3.7	5.5	7.5	11.0	15.0	18.5	22.0	30.0	37	45.0	55.0	75.0	90.0
Typical shaft output [hp]	3.0	4.0	5.0	7.5	10.0	15.0	20.0	25.0	30.0	40.0	50.0	60.0	70.0	100.0	125.0
IP20 frame	H9	H9	H9	H9	H9	H10	H10	H6	H6	H6	H7	H7	H7	H8	H8
Max. cable size in terminals (line power, motor) [mm ² /AWG]	4/10	4/10	4/10	4/10	4/10	10/8	10/8	35/2	35/2	35/2	50/1	50/1	50/1	95/0	120/ (4/0)
Output current - 104 °F [40 °C] ambient temperature															
Continuous (3 x 525–550 V) [A]	4.1	5.2	6.4	9.5	11.5	19.0	23.0	28.0	36.0	43.0	54.0	65.0	87.0	105.0	137.0
Intermittent (3 x 525–550 V) [A]	4.5	5.7	7.0	10.5	12.7	20.9	25.3	30.8	39.6	47.3	59.4	71.5	95.7	115.5	150.7
Continuous (3x551–600 V) [A]	3.9	4.9	6.1	9.0	11.0	18.0	22.0	27.0	34.0	41.0	52.0	62.0	83.0	100.0	131.0
Intermittent (3x551–600 V) [A]	4.3	5.4	6.7	9.9	12.1	19.8	24.2	29.7	37.4	45.1	57.2	68.2	91.3	110.0	144.1
Max. input current															
Continuous (3 x 525–550 V) [A]	3.7	5.1	5.0	8.7	11.9	16.5	22.5	27.0	33.1	45.1	54.7	66.5	81.3	109.0	130.9
Intermittent (3 x 525–550 V) [A]	4.1	5.6	6.5	9.6	13.1	18.2	24.8	29.7	36.4	49.6	60.1	73.1	89.4	119.9	143.9
Continuous (3x551–600 V) [A]	3.5	4.8	5.6	8.3	11.4	15.7	21.4	25.7	31.5	42.9	52.0	63.3	77.4	103.8	124.5
Intermittent (3x551–600 V) [A]	3.9	5.3	6.2	9.2	12.5	17.3	23.6	28.3	34.6	47.2	57.2	69.6	85.1	114.2	137.0
Max. electrical fuses	See chapter 5.2.3 Fuses and Circuit Breakers														
Estimated power loss [W], best case/typical ¹⁾	65	90	110	132	180	216	294	385	458	542	597	727	1092	1380	1658
Weight enclosure IP54 [kg]	14.6 [6.6]	14.6 [6.6]	14.6 [6.6]	14.6 [6.6]	14.6 [6.6]	25.35 [11.5]	25.35 [11.5]	54.01 [24.5]	54.01 [24.5]	54.01 [24.5]	79.37 [36.0]	79.37 [36.0]	79.37 [36.0]	112. 44 [51.0]	112. 44 [51.0]
Efficiency [%], best case/typical ¹⁾	97.9	97	97.9	98.1	98.1	98.4	98.4	98.4	98.4	98.5	98.5	98.7	98.5	98.5	98.5
Output current - 122 °F [50 °C] ambient temperature															
Continuous (3 x 525–550 V) [A]	2.9	3.6	4.5	6.7	8.1	13.3	16.1	19.6	25.2	30.1	37.8	45.5	60.9	73.5	95.9
Intermittent (3 x 525–550 V) [A]	3.2	4.0	4.9	7.4	8.9	14.6	17.7	21.6	27.7	33.1	41.6	50.0	67.0	80.9	105.5
Continuous (3x551–600 V) [A]	2.7	3.4	4.3	6.3	7.7	12.6	15.4	18.9	23.8	28.7	36.4	43.3	58.1	70.0	91.7
Intermittent (3x551–600 V) [A]	3.0	3.7	4.7	6.9	8.5	13.9	16.9	20.8	26.2	31.6	40.0	47.7	63.9	77.0	100.9

Table 8.8 3x525–600 V AC, P2K2–P90K, H6–H10

1) At rated load conditions

8.2 General Specifications

Protection and features

- Electronic thermal motor protection against overload.
- Temperature monitoring of the heatsink ensures that the adjustable frequency drive trips in case of overtemperature.
- The adjustable frequency drive is protected against short-circuits between motor terminals U, V, W.
- When a motor phase is missing, the adjustable frequency drive trips and issues an alarm.
- When a line phase is missing, the adjustable frequency drive trips or issues a warning (depending on the load).
- Monitoring of the intermediate circuit voltage ensures that the adjustable frequency drive trips when the intermediate circuit voltage is too low or too high.
- The adjustable frequency drive is protected against ground faults on motor terminals U, V, W.

Line power supply (L1, L2, L3)

Supply voltage	200–240 V \pm 10%
Supply voltage	380–480 V \pm 10%
Supply voltage	525–600 V \pm 10%
Supply frequency	50/60 Hz
Max. temporary imbalance between line phases	3.0% of rated supply voltage
True Power Factor (λ)	\geq 0.9 nominal at rated load
Displacement Power Factor ($\cos\phi$) near unity	(>0.98)
Switching on the input supply L1, L2, L3 (power-ups) enclosure frame H1-H5, I2, I3, I4	Max. 2 times/min.
Switching on the input supply L1, L2, L3 (power-ups) enclosure frame H6-H8, I6-I8	Max. 1 time/min.
Environment according to EN 60664-1	overvoltage category III/pollution degree 2
The unit is suitable for use on a circuit capable of delivering not more than 100,000 RMS symmetrical Amperes, 240/480 V maximum.	

Motor output (U, V, W)

Output voltage	0–100% of supply voltage
Output frequency	0–200 Hz (VVC ^{plus}), 0–400 Hz (u/f)
Switching on output	Unlimited
Ramp times	0.05–3600 s

Cable lengths and cross-sections

Max. motor cable length, shielded/armored (EMC-compatible installation)	See chapter 2.8.2 EMC Test Results
Max. motor cable length, non-shielded/unarmored	50 m
Max. cross-section to motor, line power*	
Cross-section DC terminals for filter feedback on enclosure frame H1-H3, I2, I3, I4	4 mm ² /11 AWG
Cross-section DC terminals for filter feedback on enclosure frame H4-H5	16 mm ² /6 AWG
Maximum cross-section to control terminals, rigid wire	2.5 mm ² /14 AWG)
Maximum cross-section to control terminals, flexible cable	2.5 mm ² /14 AWG)
Minimum cross-section to control terminals	0.05 mm ² /30 AWG

*See chapter 8.1.2 Line Power Supply 3x380–480 V AC for more information.

Digital inputs	
Programmable digital inputs	4
Terminal number	18, 19, 27, 29
Logic	PNP or NPN
Voltage level	0–24 V DC
Voltage level, logic '0' PNP	<5 V DC
Voltage level, logic '1' PNP	>10 V DC
Voltage level, logic '0' NPN	>19 V DC
Voltage level, logic '1' NPN	<14 V DC
Maximum voltage on input	28 V DC
Input resistance, R_i	Approx. 4 k Ω
Digital input 29 as thermistor input	Fault: >2.9 k Ω and no fault: <800 Ω
Digital input 29 as Pulse input	Max frequency 32 kHz Push-Pull Driven & 5 kHz (O.C.)

Analog inputs	
Number of analog inputs	2
Terminal number	53, 54
Terminal 53 mode	Parameter 6-19: 1=voltage, 0=current
Terminal 54 mode	Parameter 6-29: 1=voltage, 0=current
Voltage level	0–10 V
Input resistance, R_i	Approx. 10 k Ω
Max. voltage	20 V
Current level	0/4 to 20 mA (scalable)
Input resistance, R_i	<500 Ω
Max. current	29 mA

Analog output	
Number of programmable analog outputs	2
Terminal number	42, 45 ¹⁾
Current range at analog output	0/4–20 mA
Max. load to common at analog output	500 Ω
Max. voltage at analog output	17 V
Accuracy on analog output	Max. error: 0.4% of full scale
Resolution on analog output	10 bit

¹⁾ Terminal 42 and 45 can also be programmed as digital outputs.

Digital output	
Number of digital outputs	2
Terminal number	42, 45 ¹⁾
Voltage level at digital output	17 V
Max. output current at digital output	20 mA
Max. load at digital output	1 k Ω

¹⁾ Terminals 42 and 45 can also be programmed as analog output.

Control card, RS-485 serial communication^{A)}

Terminal number	68 (P, TX+, RX+), 69 (N, TX-, RX-)
Terminal number	61 Common for terminals 68 and 69

Control card, 24 V DC output

Terminal number	12
Max. load	80 mA

Relay output

Programmable relay output	2
Relay 01 and 02	01-03 (NC), 01-02 (NO), 04-06 (NC), 04-05 (NO)
Max. terminal load (AC-1) ¹⁾ on 01-02/04-05 (NO) (Resistive load)	250 V AC, 3 A
Max. terminal load (AC-15) ¹⁾ on 01-02/04-05 (NO) (Inductive load @ cosφ 0.4)	250 V AC, 0.2 A
Max. terminal load (DC-1) ¹⁾ on 01-02/04-05 (NO) (Resistive load)	30 V DC, 2 A
Max. terminal load (DC-13) ¹⁾ on 01-02/04-05 (NO) (Inductive load)	24 V DC, 0.1 A
Max. terminal load (AC-1) ¹⁾ on 01-03/04-06 (NC) (Resistive load)	250 V AC, 3 A
Max. terminal load (AC-15) ¹⁾ on 01-03/04-06 (NC) (Inductive load @ cosφ 0.4)	250 V AC, 0.2 A
Max. terminal load (DC-1) ¹⁾ on 01-03/04-06 (NC) (Resistive load)	30 V DC, 2 A
Min. terminal load on 01-03 (NC), 01-02 (NO) 24 V DC 10 mA, 24 V AC 20 mA	
Environment according to EN 60664-1	Overvoltage category III/pollution degree 2

¹⁾ IEC 60947 parts 4 and 5.

 Control card, 10 V DC output^{A)}

Terminal number	50
Output voltage	10.5 V ±0.5 V
Max. load	25 mA

^{A)} All inputs, outputs, circuits, DC supplies and relay contacts are galvanically isolated from the supply voltage (PELV) and other high-voltage terminals.

Surroundings

Enclosure	IP20
Enclosure kit available	IP21, TYPE 1
Vibration test	1.0 g
Max. relative humidity	5%–95% (IEC 60721-3-3; Class 3K3 (non-condensing) during operation)
Aggressive environment (IEC 60721-3-3), coated (standard) frame H1-H5	Class 3C3
Aggressive environment (IEC 60721-3-3), non-coated frame H6-H10	Class 3C2
Aggressive environment (IEC 60721-3-3), coated (optional) frame H6-H10	Class 3C3
Aggressive environment (IEC 60721-3-3), non-coated frame I2-I8	Class 3C2
Test method according to IEC 60068-2-43 H2S (10 days)	
Ambient temperature	See max. output current at 104/122 °F [40/50 °C] in <i>chapter 8.1.2 Line Power Supply 3x380–480 V AC</i>

Derating for high ambient temperature, see *chapter 8.5 Derating according to Ambient Temperature and Switching Frequency* *chapter 8.5 Derating according to Ambient Temperature and Switching Frequency*.

Minimum ambient temperature during full-scale operation	32 °F [0 °C]
Minimum ambient temperature at reduced performance	-4 °F [-20 °C]
Minimum ambient temperature at reduced performance	14 °F [-10 °C]
Temperature during storage/transport	-22 to +149/158 °F [-30 to +65/70 °C]
Maximum altitude above sea level without derating	3,300 ft [1000 m]
Maximum altitude above sea level with derating	10,000 ft [3000 m]
Derating for high altitude, see	
Safety standards	EN/IEC 61800-5-1, UL 508C
EMC standards, Emission	EN 61800-3, EN 61000-6-3/4, EN 55011, IEC 61800-3
EMC standards, Immunity	EN 61800-3, EN 61000-3-12, EN 61000-6-1/2, EN 61000-4-2, EN 61000-4-3, EN 61000-4-4, EN 61000-4-5, EN 61000-4-6

8.3 Acoustic Noise or Vibration

If the motor or the equipment driven by the motor, e.g., a fan blade, is making noise or vibrations at certain frequencies, try the following:

- Speed Bypass, parameter group 4-6* *Speed Bypass*
- Overmodulation, 14-03 *Overmodulation* set to [0] *Off*
- Switching pattern and switching frequency parameter group 14-0* *Inverter Switching*
- Resonance Dampening, 1-64 *Resonance Dampening*

The acoustic noise from the adjustable frequency drive comes from three sources:

1. DC intermediate circuit coils
2. Integral fan
3. RFI filter choke

Frame	Level [dBA]
H1	57.3
H2	59.5
H3	53.8
H4	64
H5	63.7
H6	71.5
H7	67.5 (75 kW 71.5 dB)
H8	73.5
H9	60
H10	62.9
I2	50.2
I3	54
I4	60.8
I6	70
I7	62
I8	65.6

Table 8.9 Typical Values Measured at a Distance of 3.3 ft [1 m] from the Unit

8.4 dU/Dt

	Cable length (ft [m])	AC line voltage [V]	Rise time [usec]	V _{peak} [kV]	dU/dt [kV/usec]
200 V 0.36 hp [0.25 kW]	16.4 [5]	240	0.121	0.498	3.256
	82 [25]	240	0.182	0.615	2.706
	164 [50]	240	0.258	0.540	1.666
200 V 0.5 hp [0.37 kW]	16.4 [5]	240	0.121	0.498	3.256
	82 [25]	240	0.182	0.615	2.706
	164 [50]	240	0.258	0.540	1.666
200 V 1 hp [0.75 kW]	16.4 [5]	240	0.121	0.498	3.256
	82 [25]	240	0.182	0.615	2.706
	164 [50]	240	0.258	0.540	1.666
200 V 2 hp [1.5 kW]	16.4 [5]	240	0.121	0.498	3.256
	82 [25]	240	0.182	0.615	2.706
	164 [50]	240	0.258	0.540	1.666
200 V 3 hp [2.2 kW]	16.4 [5]	240	0.18	0.476	2.115
	82 [25]	240	0.230	0.615	2.141
	164 [50]	240	0.292	0.566	1.550
200 V 5 hp [3.7 kW]	16.4 [5]	240	0.168	0.570	2.714
	82 [25]	240	0.205	0.615	2.402
	164 [50]	240	0.252	0.620	1.968
200 V 7.5 hp [5.5 kW]	16.4 [5]	240	0.128	0.445	2781
	82 [25]	240	0.224	0.594	2121
	164 [50]	240	0.328	0.596	1454
200 V 10 hp [7.5 kW]	16.4 [5]	240	0.18	0.502	2244
	82 [25]	240	0.22	0.598	2175
	164 [50]	240	0.292	0.615	1678
200 V 15 hp [11 kW]	118 [36]	240	0.176	0.56	2545
	164 [50]	240	0.216	0.599	2204
400 V 5 hp [0.37 kW]	16.4 [5]	400	0.160	0.808	4.050
	82 [25]	400	0.240	1.026	3.420
	164 [50]	400	0.340	1.056	2.517
400 V 1 hp [0.75 kW]	16.4 [5]	400	0.160	0.808	4.050
	82 [25]	400	0.240	1.026	3.420
	164 [50]	400	0.340	1.056	2.517
400 V 2 hp [1.5 kW]	16.4 [5]	400	0.160	0.808	4.050
	82 [25]	400	0.240	1.026	3.420
	164 [50]	400	0.340	1.056	2.517
400 V 3 hp [2.2 kW]	16.4 [5]	400	0.190	0.760	3.200
	82 [25]	400	0.293	1.026	2.801
	164 [50]	400	0.422	1.040	1.971
400 V 5 hp [3.0 kW]	16.4 [5]	400	0.190	0.760	3.200
	82 [25]	400	0.293	1.026	2.801
	164 [50]	400	0.422	1.040	1.971
400 V 5 hp [4.0 kW]	16.4 [5]	400	0.190	0.760	3.200
	82 [25]	400	0.293	1.026	2.801
	164 [50]	400	0.422	1.040	1.971
400 V 7.5 hp [5.5 kW]	16.4 [5]	400	0.168	0.81	3.857
	82 [25]	400	0.239	1.026	3.434
	164 [50]	400	0.328	1.05	2.560

	Cable length (ft [m])	AC line voltage [V]	Rise time [usec]	V _{peak} [kV]	dU/dt [kV/usec]
400 V 10 hp [7.5 kW]	16.4 [5]	400	0.168	0.81	3.857
	82 [25]	400	0.239	1.026	3.434
	164 [50]	400	0.328	1.05	2.560
400 V 15 hp [11 kW]	16.4 [5]	400	0.116	0.69	4871
	82 [25]	400	0.204	0.985	3799
	164 [50]	400	0.316	1.01	2563
400 V 20 hp [15 kW]	16.4 [5]	400	0.139	0.864	4.955
	164 [50]	400	0.338	1.008	2.365
400 V 25 hp [18.5 kW]	16.4 [5]	400	0.132	0.88	5.220
	82 [25]	400	0.172	1.026	4.772
	164 [50]	400	0.222	1.00	3.603
400 V 30 hp [22 kW]	16.4 [5]	400	0.132	0.88	5.220
	82 [25]	400	0.172	1.026	4.772
	164 [50]	400	0.222	1.00	3.603
400 V 40 hp [30 kW]	32.8 [10]	400	0.376	0.92	1.957
	164 [50]	400	0.536	0.97	1.448
	328 [100]	400	0.696	0.95	1.092
	492 [150]	400	0.8	0.965	0.965
	32.8 [10]	480	0.384	1.2	2.5
	164 [50]	480	0.632	1.18	1.494
	328 [100]	480	0.712	1.2	1.348
	492 [150]	480	0.832	1.17	1.125
	32.8 [10]	500	0.408	1.24	2.431
	164 [50]	500	0.592	1.29	1.743
	328 [100]	500	0.656	1.28	1.561
	492 [150]	500	0.84	1.26	1.2
400 V 50 hp [37 kW]	32.8 [10]	400	0.276	0.928	2.69
	164 [50]	400	0.432	1.02	1.889
	32.8 [10]	480	0.272	1.17	3.441
	164 [50]	480	0.384	1.21	2.521
	32.8 [10]	500	0.288	1.2	3.333
	164 [50]	500	0.384	1.27	2.646
400 V 60 hp [45 kW]	32.8 [10]	400	0.3	0.936	2.496
	164 [50]	400	0.44	0.924	1.68
	328 [100]	400	0.56	0.92	1.314
	492 [150]	400	0.8	0.92	0.92
	32.8 [10]	480	0.3	1.19	3.173
	164 [50]	480	0.4	1.15	2.3
	328 [100]	480	0.48	1.14	1.9
	492 [150]	480	0.72	1.14	1.267
	32.8 [10]	500	0.3	1.22	3.253
	164 [50]	500	0.38	1.2	2.526
	328 [100]	500	0.56	1.16	1.657
	492 [150]	500	0.74	1.16	1.254
400 V 75 hp [55 kW]	32.8 [10]	400	0.46	1.12	1.948
		480	0.468	1.3	2.222
400 V 100 hp [75 kW]	32.8 [10]	400	0.502	1.048	1.673
		480	0.52	1.212	1.869
		500	0.51	1.272	1.992

	Cable length (ft [m])	AC line voltage [V]	Rise time [usec]	V _{peak} [kV]	dU/dt [kV/usec]
400 V 90 kW	32.8 [10]	400	0.402	1.108	2.155
		400	0.408	1.288	2.529
		400	0.424	1.368	2.585
600 V 10 hp [7.5 kW]	16.4 [5]	525	0.192	0.972	4.083
	164 [50]	525	0.356	1.32	2.949
	16.4 [5]	600	0.184	1.06	4.609
	164 [50]	600	0.42	1.49	2.976

Table 8.10

8.5 Derating according to Ambient Temperature and Switching Frequency

The ambient temperature measured over 24 hours should be at least 9 °F [5 °C] lower than the max. ambient temperature. If the adjustable frequency drive is operated at a high ambient temperature, the continuous output current should be decreased.

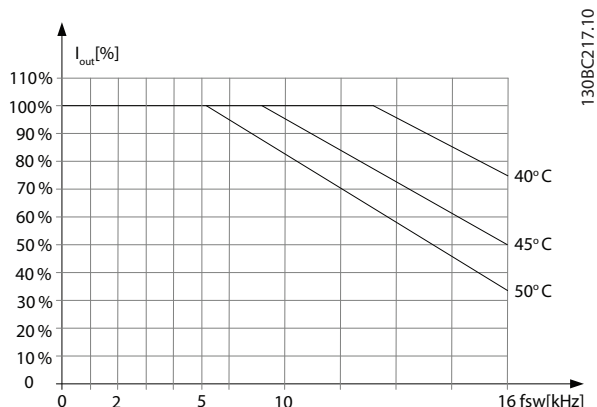

Figure 8.1 200 V IP20 H1 0.34-1 hp [0.25-0.75 kW]

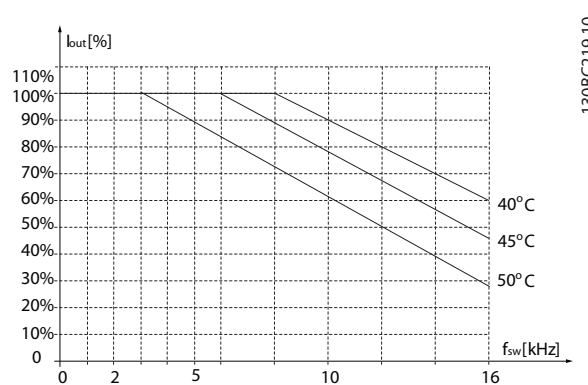

Figure 8.3 200 V IP20 H2 3 hp [2.2 kW]

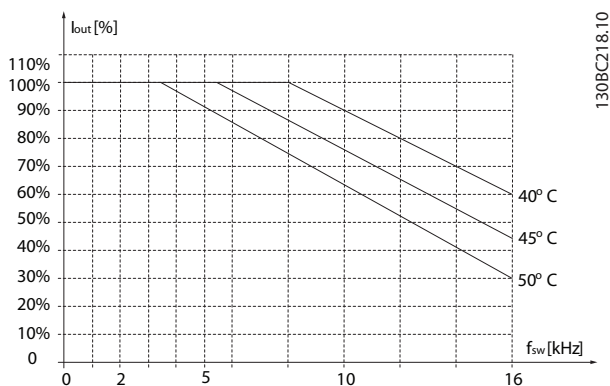

Figure 8.2 400 V IP20 H1 0.5-2 hp [0.37-1.5 kW]

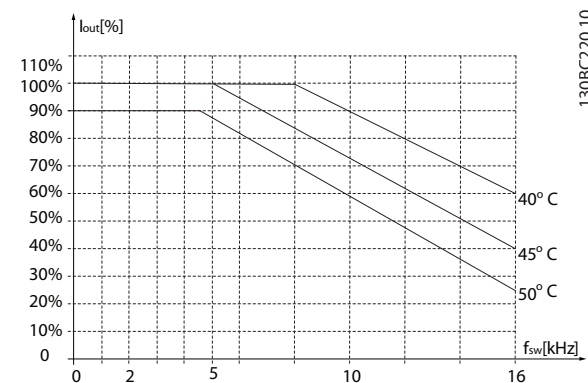

Figure 8.4 400 V IP20 H2 3-5 hp [2.2-4.0 kW]

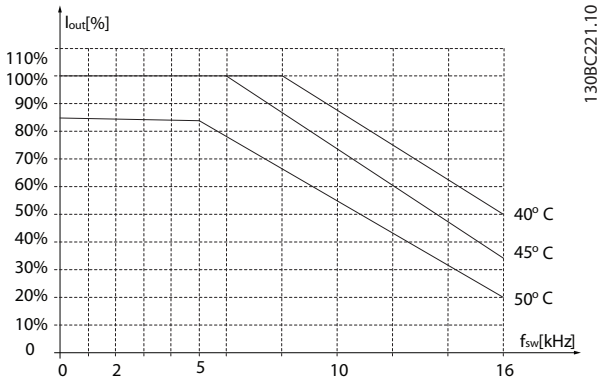

Figure 8.5 200 V IP20 H3 5 hp [3.7 kW]

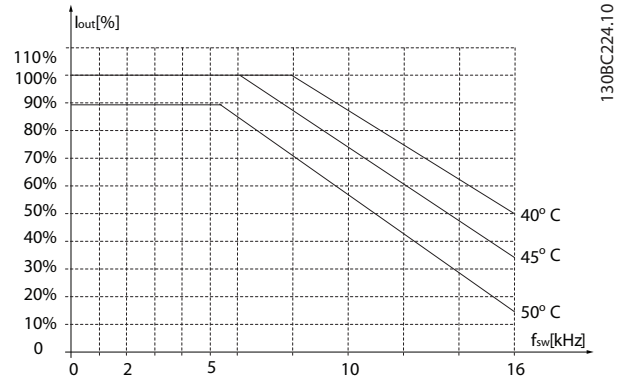

Figure 8.8 400 V IP20 H4 15-20 hp [11-15 kW]

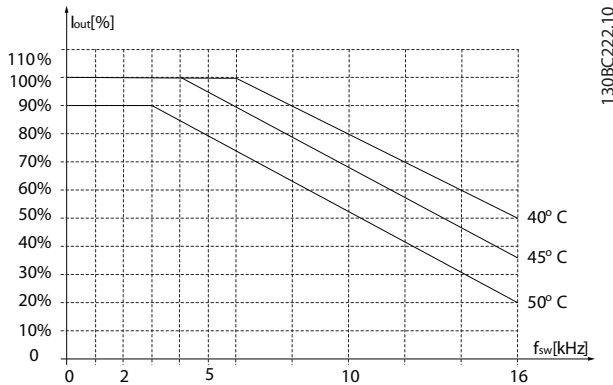

Figure 8.6 400 V IP20 H3 7.5-10 hp [5.5-7.5 kW]

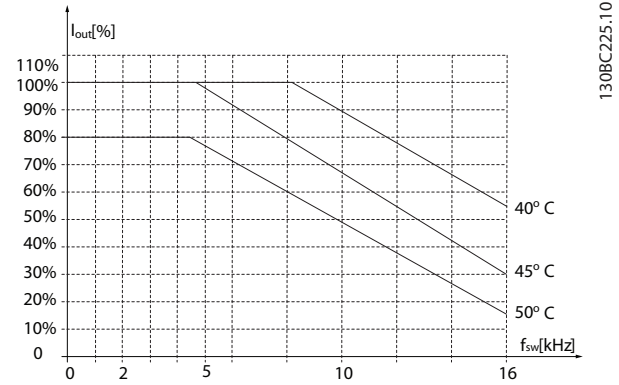

Figure 8.9 200 V IP20 H5 15 hp [11 kW]

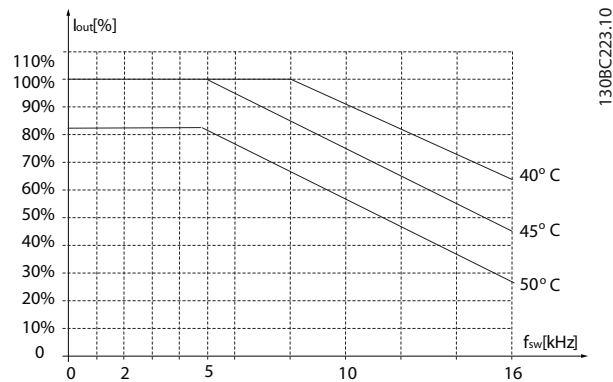

Figure 8.7 200 V IP20 H4 7.5-10 hp [5.5-7.5 kW]

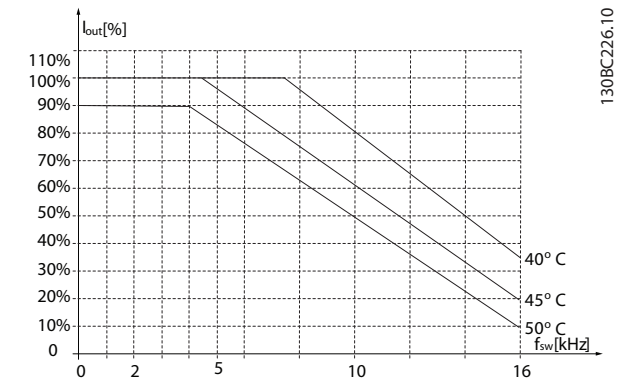

Figure 8.10 400 V IP20 H5 25-30 hp [18.5-22 kW]

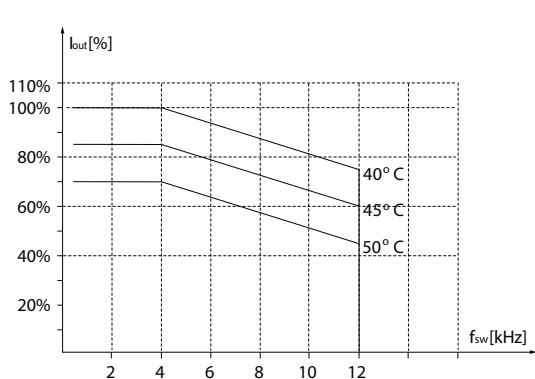

Figure 8.11 200 V IP20 H6 20–25 hp [15–18.5 kW]

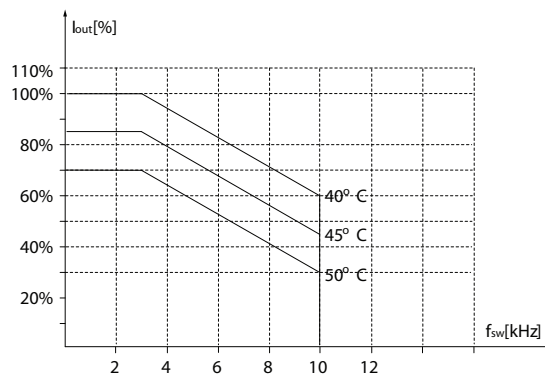

Figure 8.14 600 V IP20 H6 30–40 hp [22–30 kW]

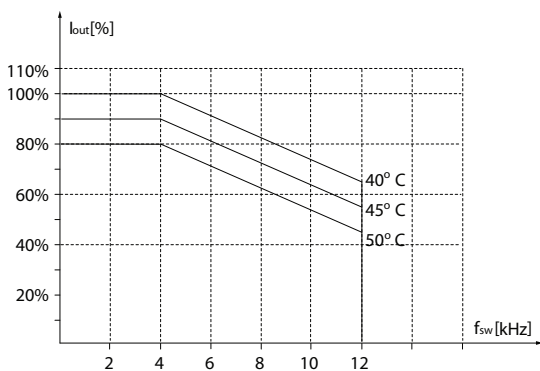

Figure 8.12 400 V IP20 H6 40–50 hp [30–37 kW]

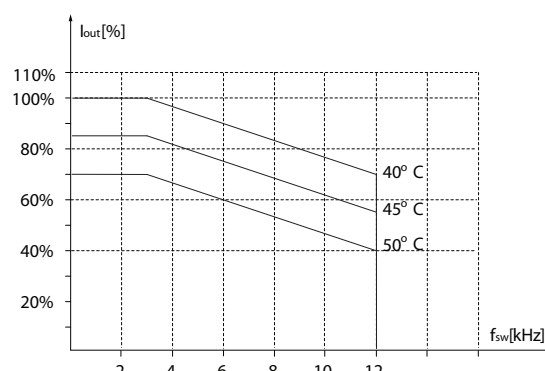

Figure 8.15 200 V IP20 H7 30–40 hp [22–30 kW]

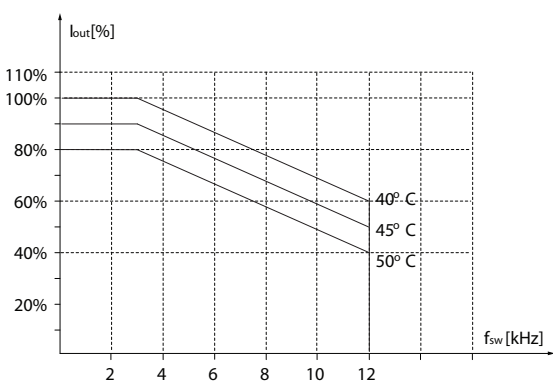

Figure 8.13 400 V IP20 H6 60 hp [45 kW]

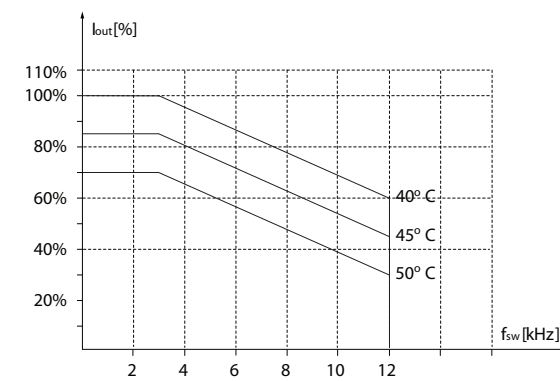

Figure 8.16 400 V IP20 H7 75–100 hp [55–75 kW]

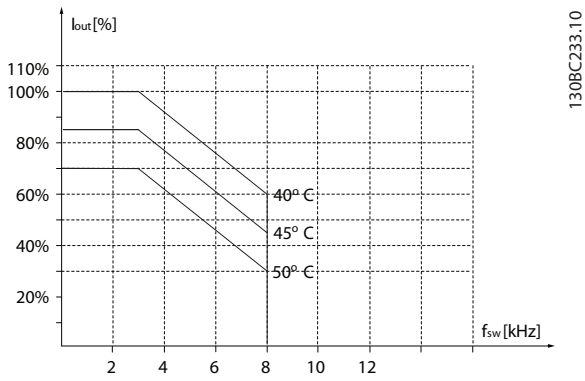

Figure 8.17 600 V IP20 H7 60–75 hp [45–55 kW]

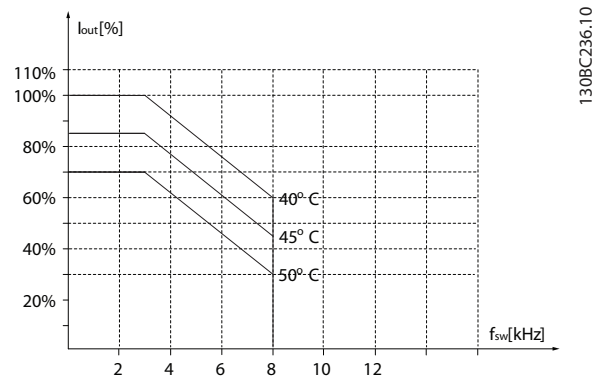

Figure 8.20 600 V IP20 H8 100–125 hp [75–90 kW]

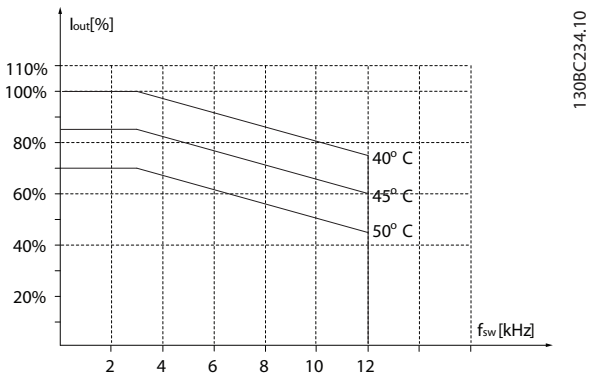

Figure 8.18 200 V IP20 H8 50–60 hp [37–45 kW]

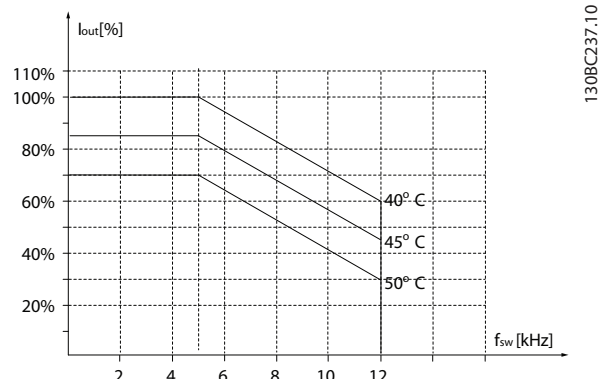

Figure 8.21 600 V IP20 H9 3–4 hp [2.2–3 kW]

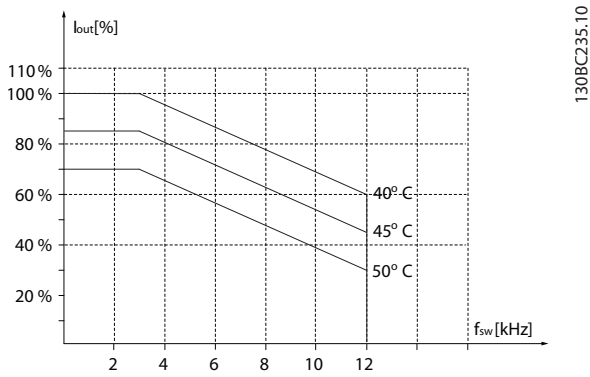

Figure 8.19 400 V IP20 H8 125 hp [90 kW]

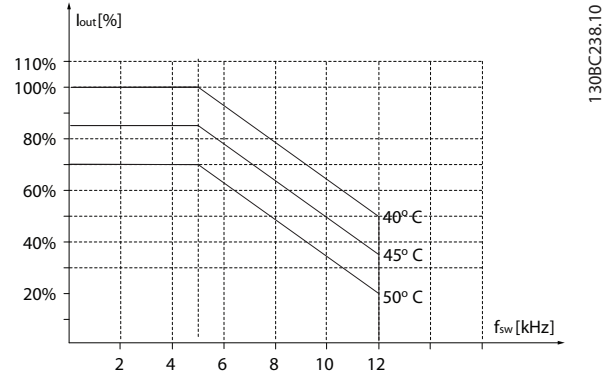

Figure 8.22 600 V IP20 H9 7.5–10 hp [5.5–7.5 kW]

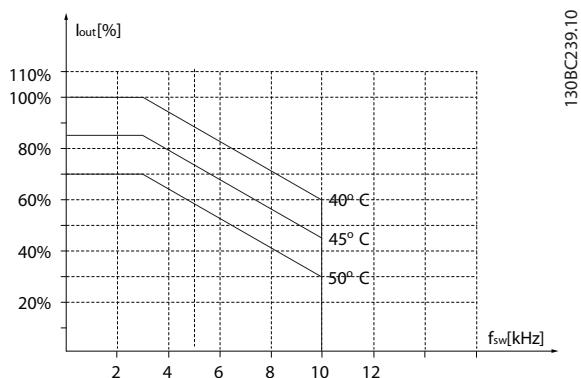

Figure 8.23 600 V IP20 H10 15-20 hp [11-15 kW]

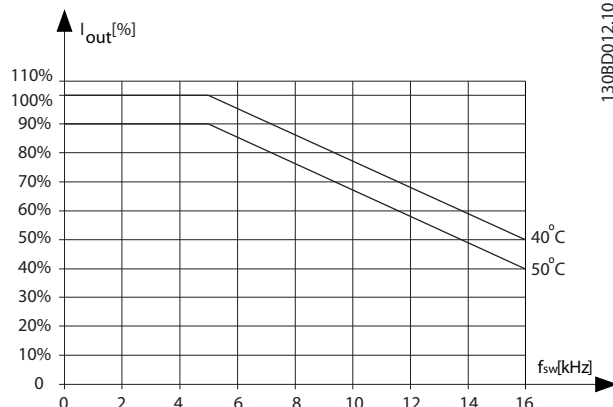

Figure 8.26 400 V IP54 I4 15-25 hp [11-18.5 kW]

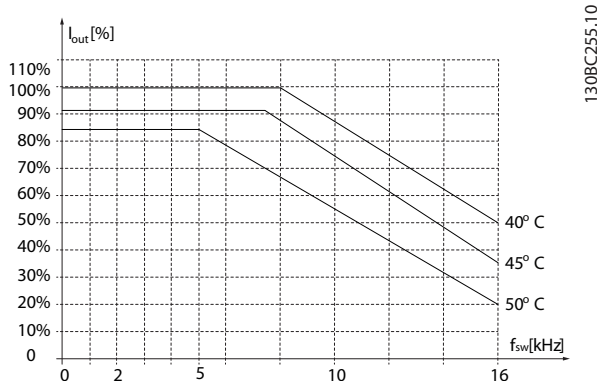

Figure 8.24 400 V IP54 I2 1-5 hp [0.75-4.0 kW]

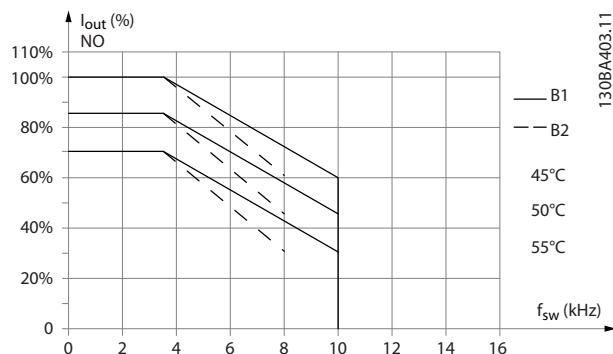

Figure 8.27 400 V IP54 I5 15-25 hp [11-18.5 kW]

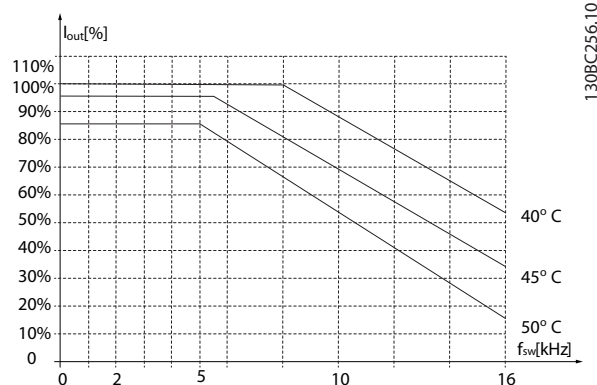

Figure 8.25 400 V IP54 I3 7.5-10 hp [5.5-7.5 kW]

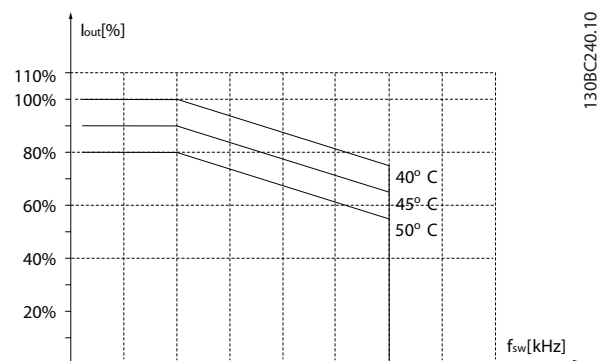

Figure 8.28 400 V IP54 I6 30-40 hp [22-30 kW]

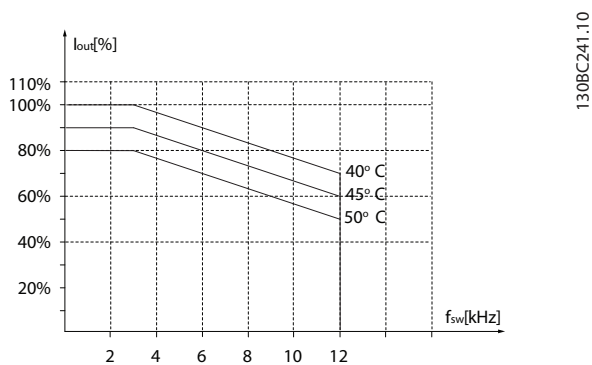

Figure 8.29 400 V IP54 I6 50 hp [37 kW]

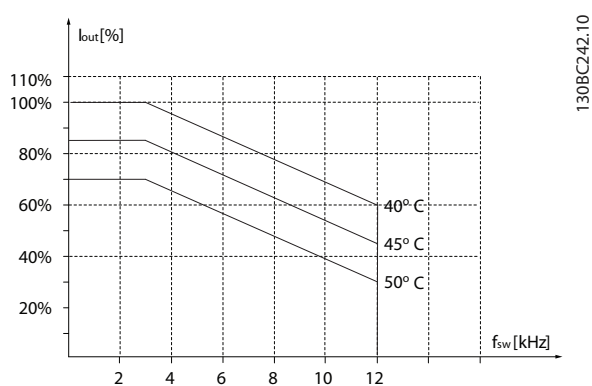

Figure 8.30 400 V IP54 I7 60–75 hp [45–55 kW]

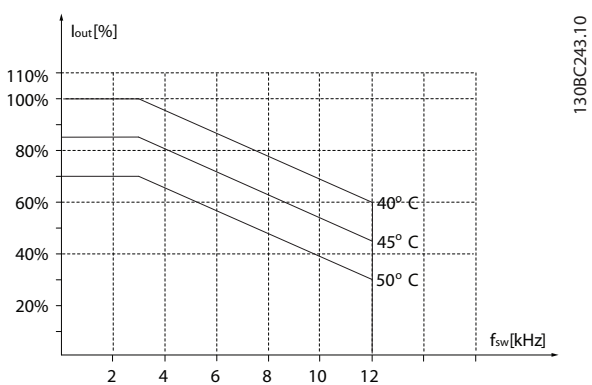

Figure 8.31 400 V IP54 I8 100–125 hp [75–90 kW]

Index

A

Abbreviations..... 5

Acoustic Noise..... 117

Adjustable Frequency Drive Hardware Set-up..... 87

Adjustable Frequency Drive Set-up..... 88

Advanced Vector Control..... 6

Aggressive Environments..... 12

Air Humidity..... 11

Analog inputs..... 6, 115

Analog Inputs..... 6

Analog output..... 115

Application Examples..... 17

B

Balancing contractor..... 23

Better Control..... 15

Break-away torque..... 6

Building Management System, BMS..... 14

Bypass frequency ranges..... 20

C

Cable lengths and cross-sections..... 114

CAV system..... 19

CE Conformity and Labeling..... 10

Central VAV systems..... 18

Changes made..... 74

Changes Made..... 84

Closed-loop set-up wizard..... 74

Closed-loop Set-up Wizard..... 31, 74

CO2 sensor..... 19

Coasting..... 6, 103, 104

Comparison of Energy Savings..... 13

Condenser Pumps..... 22

Connecting to Line Power and Motor..... 60

Constant Air Volume..... 19

Control card, 10 V DC output..... 116

Control card, 24 V DC output..... 116

Control card, RS-485 serial communication..... 115

Control potential..... 25

Control Structure Closed-loop..... 28

Control Structure Open-loop..... 26

Control Terminals..... 72

Control Word..... 103

Controlling Fans and Pumps..... 12

Cooling Tower Fan..... 20

D

Dampers..... 18

DANGEROUS VOLTAGE..... 9

Data Types Supported by the Adjustable Frequency Drive..... 92

DC brake..... 103

Decoupling Plate..... 48

Definitions..... 6

Differential pressure..... 25

Digital inputs..... 115

Digital output..... 115

Discharge Time..... 10

Display..... 73

Disposal Instruction..... 10

Drive Configurator..... 49

E

Electrical Installation in General..... 59

Electrical Overview..... 58

EMC Directive 89/336/EEC..... 11

EMC Precautions..... 88

EMC-compatible Electrical Installation..... 70

EMC-compatible Installation..... 70

Emission Requirements..... 36

Energy savings..... 14

Energy Savings..... 12

Evaporator flow rate..... 23

Example of Energy Savings..... 13

Extreme Running Conditions..... 42

F

FC Profile..... 103

FC with Modbus RTU..... 88

Feedback Conversion..... 28

Field Mounting..... 58

Flow meter..... 23

Freeze output..... 6

Function Codes..... 98

Fuses and Circuit Breakers..... 67

G

Galvanic Isolation.....	41
General Aspects of EMC Emissions.....	35
General Aspects of Harmonics Emission.....	38
General Specifications.....	114
Ground Leakage Current.....	42

H

Harmonics Emission Requirements.....	39
Harmonics Test Results (Emission).....	39
Hold output frequency.....	103
How to Order.....	49
How to Program.....	73

I

IGVs.....	18
Immunity Requirements.....	41
Index (IND).....	91
Initialize the Adjustable Frequency Drive.....	85
Installation at high altitudes.....	9
Intermediate circuit.....	42, 117
IP21/TYPE 1 Enclosure Kit.....	46

J

Jog.....	6, 103
----------	--------

K

Keypad.....	7
-------------	---

L

Laws of Proportionality.....	13
LCP.....	6, 27
LCP Copy.....	84
Leakage Current.....	42
Line drop-out.....	43
Line power supply.....	8
Line power supply (L1, L2, L3).....	114
Line Power Supply 3x200–240 V AC.....	106
Line Power Supply 3x380–480 V AC.....	107, 111
Line Power Supply 3x525–600 V AC.....	113
Local (Hand On) and Remote (Auto On) Control.....	27
Local Control Panel (LCP).....	73
Local speed determination.....	23

Low evaporator temperature.....	23
---------------------------------	----

M

Main Menu.....	84
Manual PI Adjustment.....	34
Menu Key.....	73
Menus.....	74
Message Length (LGE).....	89
Modbus Communication.....	87
Modbus Exception Codes.....	98
Modbus RTU.....	94
Modbus RTU Overview.....	93
Moment of inertia.....	42
Motor output (U, V, W).....	114
Motor phases.....	42
Motor protection.....	114
Motor set-up.....	74
Motor thermal protection.....	105
Motor Thermal Protection.....	43
Motor-generated overvoltage.....	42
Multiple pumps.....	25

N

Navigation keys and indicator lights (LEDs).....	73
Network Configuration.....	94
Network Connection.....	86

O

Operation keys and indicator lights (LEDs).....	73
Options and Accessories.....	45, 51
Overcurrent protection.....	67

P

Parameter Number (PNU).....	91
Parameter Values.....	99
Payback period.....	14
PELV - Protective Extra Low Voltage.....	41
Power Factor.....	8
Primary Pumps.....	23
Programmable minimum frequency setting.....	20
Programming with.....	73
Protection.....	12, 41, 42, 67
Protection and Features.....	114
Protocol Overview.....	88

Public supply network.....	39		
Pump impeller.....	22		
Q			
Quick Menu.....	74		
Quick Transfer of Parameter Settings between Multiple Adjustable Frequency Drives.....	84		
R			
Rated motor speed.....	6		
RCD.....	6, 42		
Read Holding Registers (03 HEX).....	101		
Readout and Programming of Indexed Parameters.....	84		
Recommended initialization.....	85		
Reference Handling.....	29		
Relay output.....	116		
Residual Current Device.....	42		
RS-485.....	86		
RS-485 Installation and Set-up.....	86		
S			
Safety Note.....	9		
Safety Regulations.....	9		
Secondary Pumps.....	25		
Serial communication port.....	6		
Short circuit (motor phase – phase).....	42		
Soft starter.....	15		
Star/Delta Starter.....	15		
Start-up Wizard for Open-loop Applications.....	74		
Status.....	74		
Status Word.....	104		
Surroundings.....	116		
Switching on the input supply.....	114		
Switching on the output.....	42		
T			
The EMC directive (89/336/EEC).....	10		
The low-voltage directive (73/23/EEC).....	10		
The machinery directive (98/37/EEC).....	10		
Thermistor.....	6		
Throttling valve.....	22		
Tuning the Drive Closed-loop Controller.....	34		
Two finger initialization.....	85		
Type Code String.....	50		
U			
UL compliance.....	67		
UNINTENDED START.....	9		
Using an Adjustable Frequency Drive Saves Money.....	16		
V			
Variable Air Volume.....	18		
Variable control of flow and pressure.....	15		
Varying Flow over 1 Year.....	14		
VAV.....	18		
Vibration and Shock.....	12		
Vibrations.....	20		
VVCplus.....	8		
W			
What is Covered.....	11		
Wizard for open-loop applications.....	74		



www.danfoss.com/drives

.....
Danfoss shall not be responsible for any errors in catalogs, brochures or other printed material. Danfoss reserves the right to alter its products at any time without notice, provided that alterations to products already on order shall not require material changes in specifications previously agreed upon by Danfoss and the Purchaser. All trademarks in this material are property of the respective companies. Danfoss and the Danfoss logotype are trademarks of Danfoss A/S. All rights reserved.
.....

