



Quick Guide

VLT[®] HVAC Basic Drive FC 111



Contents

1 Introduction	2
1.1 Purpose of the Quick Guide	2
1.2 Additional Resources	2
1.3 Manual and Software Version	2
1.4 Disposal	2
2 Safety	3
2.1 Safety Symbols	3
2.2 Qualified Personnel	3
2.3 Safety Precautions	3
2.4 Motor Thermal Protection	4
3 Installation	5
3.1 Mechanical Installation	5
3.2 Electrical Installation	6
4 Programming	15
4.1 Local Control Panel (LCP)	15
4.2 Set-up Wizard	16
4.3 Parameter List	30
5 Cascade Controller	33
5.1 Introduction	33
5.2 System Status and Operation	34
5.3 Start/Stop Conditions	34
5.4 Cascade Controller Wizard	35
5.5 Cascade Controller Connection	36
6 Warnings and Alarms	37
6.1 List of Warnings and Alarms	37
6.2 List of LCP Errors	39
7 Specifications	40
7.1 Mains Supply 3x380–480 V	40
7.2 EMC Emission Test Results	42
7.3 Special Conditions	43
7.4 General Technical Data	44

1 Introduction

1.1 Purpose of the Quick Guide

The quick guide provides information for safe installation and commissioning of the frequency converter.

The quick guide is intended for use by qualified personnel. Read and follow the quick guide to use the frequency converter safely and professionally, and pay particular attention to the safety instructions and general warnings. Keep this quick guide available with the frequency converter.

VLT® is a registered trademark.

1.2 Additional Resources

- *VLT® HVAC Basic Drive FC 101 Programming Guide* provides information on how to programme and includes complete parameter descriptions.
- *VLT® HVAC Basic Drive FC 101 Design Guide* provides all technical information about the frequency converter, customer design, and applications. It also lists options and accessories.

The technical documentation is available in electronic form on the documentation CD that is shipped with the product, or in print at the local Danfoss sales office.

MCT 10 Set-up Software Support

Download the software from www.danfoss.com/BusinessAreas/DrivesSolutions/Software+MCT10/MCT10+Downloads.htm.

During the installation process of the software, enter access code 81462700 to activate the FC 111 functionality. A licence key is not required for using the FC 111 functionality.

The latest software does not always contain the latest updates for frequency converters. Contact the local sales office for the latest frequency converter updates (in the form of *.upd files), or download the frequency converter updates from www.danfoss.com/BusinessAreas/DrivesSolutions/fc101driveupdates.

1.3 Manual and Software Version

This manual is regularly reviewed and updated. All suggestions for improvement are welcome.

Edition	Remarks	Software version
MG18F5xx	Replaces MG18F4xx. This edition includes contents that are related to the new software version 62.7x.	62.7x

1.4 Disposal



Equipment containing electrical components must not be disposed of together with domestic waste. It must be separately collected with electrical and electronic waste according to local and currently valid legislation.

2 Safety

2.1 Safety Symbols

The following symbols are used in this document:

⚠ WARNING

Indicates a potentially hazardous situation that could result in death or serious injury.

⚠ CAUTION

Indicates a potentially hazardous situation that could result in minor or moderate injury. It can also be used to alert against unsafe practices.

NOTICE

Indicates important information, including situations that can result in damage to equipment or property.

2.2 Qualified Personnel

Correct and reliable transport, storage, installation, operation, and maintenance are required for the trouble-free and safe operation of the frequency converter. Only qualified personnel are allowed to install or operate this equipment.

Qualified personnel are defined as trained staff, who are authorised to install, commission, and maintain equipment, systems, and circuits in accordance with pertinent laws and regulations. Additionally, the personnel must be familiar with the instructions and safety measures described in this manual.

2.3 Safety Precautions

⚠ WARNING

HIGH VOLTAGE

Frequency converters contain high voltage when connected to AC mains input, DC supply, or load sharing. Failure to perform installation, start-up, and maintenance by qualified personnel can result in death or serious injury.

- Only qualified personnel must perform installation, start-up, and maintenance.

⚠ WARNING

UNINTENDED START

When the frequency converter is connected to AC mains, DC supply, or load sharing, the motor may start at any time. Unintended start during programming, service, or repair work can result in death, serious injury, or property damage. Start the motor with an external switch, a fieldbus command, an input reference signal from the local control panel (LCP), via remote operation using MCT 10 Set-up Software, or after a cleared fault condition.

To prevent unintended motor start:

- Disconnect the frequency converter from the mains.
- Press [Off/Reset] on the LCP before programming parameters.
- Ensure that the frequency converter is fully wired and assembled when it is connected to AC mains, DC supply, or load sharing.

⚠ WARNING

DISCHARGE TIME!

Frequency converters contain DC-link capacitors that can remain charged even when the frequency converter is not powered. To avoid electrical hazards, disconnect AC mains, any permanent magnet type motors, and any remote DC-link supplies, including battery back-ups, UPS, and DC-link connections to other frequency converters. Wait for the capacitors to fully discharge before performing any service or repair work. The waiting time is listed in *Table 2.1*. Failure to wait the specified time after power has been removed before doing service or repair could result in death or serious injury.

Voltage [V]	Power range [kW]	Minimum waiting time (minutes)
3x400	0.37–7.5	4
3x400	11–90	15

Table 2.1 Discharge Time

⚠ WARNING

LEAKAGE CURRENT HAZARD

Leakage currents exceed 3.5 mA. Failure to ground the frequency converter properly can result in death or serious injury.

- Ensure the correct grounding of the equipment by a certified electrical installer.

⚠ WARNING**EQUIPMENT HAZARD**

Contact with rotating shafts and electrical equipment can result in death or serious injury.

- Ensure that only trained and qualified personnel perform installation, start-up, and maintenance.
- Ensure that electrical work conforms to national and local electrical codes.
- Follow the procedures in this manual.

⚠ CAUTION**INTERNAL FAILURE HAZARD**

An internal failure in the frequency converter can result in serious injury, when the frequency converter is not properly closed.

- Ensure that all safety covers are in place and securely fastened before applying power.

2.4 Motor Thermal Protection

Set *parameter 1-90 Motor Thermal Protection* to [4] *ETR trip 1* to enable the motor thermal protection function.

3 Installation

3.1 Mechanical Installation

3.1.1 Side-by-side Installation

The frequency converter can be mounted side-by-side but requires the clearance above and below for cooling.

NOTICE

When the IP21/NEMA Type1 option kit is mounted, ensure a distance of 50 mm (2 in) between the units.

		Power [kW(hp)]	Clearance above/ below [mm(in)]
Size	IP class	3x380–480 V	
H1	IP20	0.37–1.5 (0.5–2)	100 (4)
H2	IP20	2.2–4 (3–5)	100 (4)
H3	IP20	5.5–7.5 (7.5–10)	100 (4)
H4	IP20	11–15 (15–20)	100 (4)
H5	IP20	18.5–22 (25–30)	100 (4)
H6	IP20	30–45 (40–60)	200 (7.9)
H7	IP20	55–75 (70–100)	200 (7.9)
H8	IP20	90 (125)	225 (8.9)

Table 3.1 Clearance Required for Cooling

3.1.2 Frequency Converter Dimensions

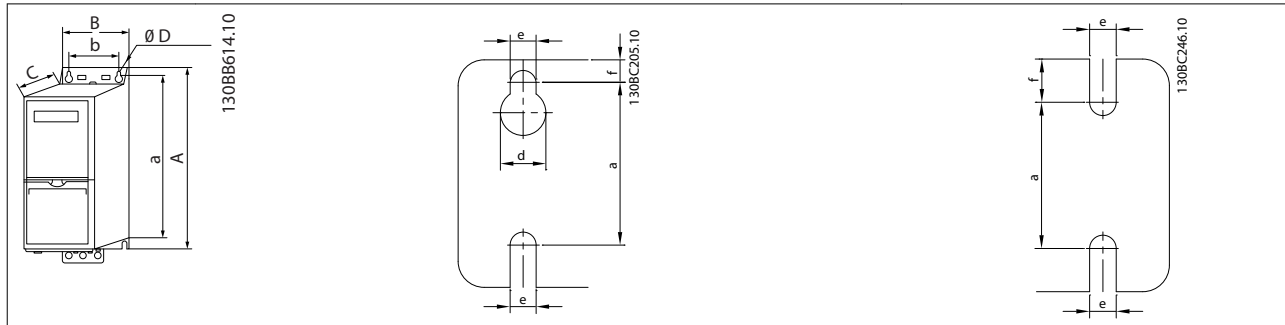

Enclosure		Power [kW(hp)]	Height [mm(in)]			Width [mm(in)]		Depth [mm(in)]	Mounting hole [mm(in)]			Maximum weight
Size	IP class	3x380–480 V	A	A ¹	a	B	b	C	d	e	f	kg(lb)
H1	IP20	0.37–1.5 (0.5–2)	195 (7.7)	273 (10.7)	183 (7.2)	75 (3.0)	56 (2.2)	168 (6.6)	9 (0.35)	4.5 (0.18)	5.3 (0.21)	2.1 (4.6)
H2	IP20	2.2–4.0 (3–5)	227 (8.9)	303 (11.9)	212 (8.3)	90 (3.5)	65 (2.6)	190 (7.5)	11 (0.43)	5.5 (0.22)	7.4 (0.29)	3.4 (7.5)
H3	IP20	5.5–7.5 (7.5–10)	255 (10.0)	329 (13.0)	240 (9.4)	100 (3.9)	74 (2.9)	206 (8.1)	11 (0.43)	5.5 (0.22)	8.1 (0.32)	4.5 (9.9)
H4	IP20	11–15 (15–20)	296 (11.7)	359 (14.1)	275 (10.8)	135 (5.3)	105 (4.1)	241 (9.5)	12.6 (0.50)	7 (0.28)	8.4 (0.33)	7.9 (17.4)
H5	IP20	18.5–22 (25–30)	334 (13.1)	402 (15.8)	314 (12.4)	150 (5.9)	120 (4.7)	255 (10)	12.6 (0.50)	7 (0.28)	8.5 (0.33)	9.5 (20.9)
H6	IP20	30–45 (40–60)	518 (20.4)	595 (23.4)/635 (25) (45 kW)	495 (19.5)	239 (9.4)	200 (7.9)	242 (9.5)	–	8.5 (0.33)	15 (0.6)	24.5 (54)

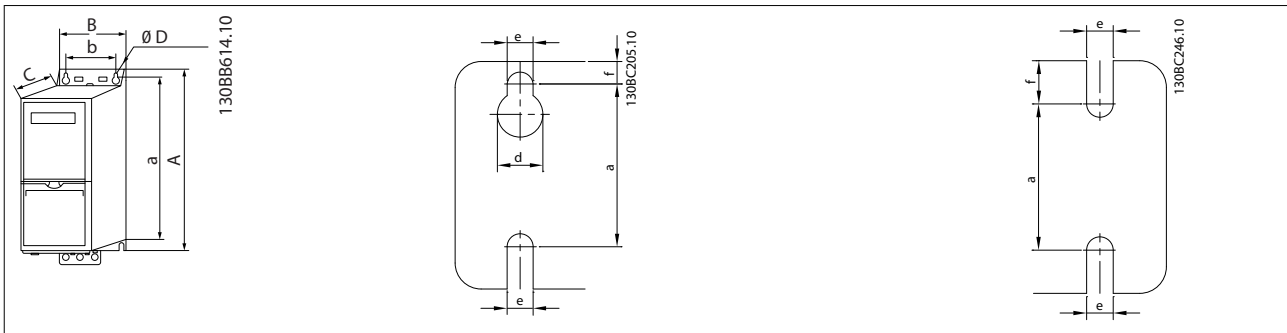

Enclosure		Power [kW(hp)]	Height [mm(in)]			Width [mm(in)]		Depth [mm(in)]	Mounting hole [mm(in)]			Maximum weight
Size	IP class	3x380–480 V	A	A ¹⁾	a	B	b	C	d	e	f	kg(lb)
H7	IP20	55–75 (70–100)	550 (21.7)	630 (24.8)/690 (27.2) (75 kW)	521 (20.5)	313 (12.3)	270 (10.6)	335 (13.2)	–	8.5 (0.33)	17 (0.67)	36 (79)
H8	IP20	90 (125)	660 (26)	800 (31.5)	631 (24.8)	375 (14.8)	330 (13)	335 (13.2)	–	8.5 (0.33)	17 (0.67)	51 (112)

1) Including decoupling plate

The dimensions are only for the physical units.

NOTICE

When installing in an application, allow space above and below the units for cooling. The amount of space for free air passage is listed in *Table 3.1*.

Table 3.2 Dimensions, Enclosure Sizes H1–H8

3.2 Electrical Installation

3.2.1 Electrical Installation in General

All cabling must comply with national and local regulations on cable cross-sections and ambient temperature. Copper conductors are required. 75 °C (167 °F) is recommended.

Enclosure size	IP class	Power [kW(hp)] 3x380–480 V	Torque [Nm(in-lb)]					
			Mains	Motor	DC connection	Control terminals	Ground	Relay
H1	IP20	0.37–1.5 (0.5–2)	0.8 (7)	0.8 (7)	0.8 (7)	0.5 (4)	0.8 (7)	0.5 (4)
H2	IP20	2.2–4.0 (3–5)	0.8 (7)	0.8 (7)	0.8 (7)	0.5 (4)	0.8 (7)	0.5 (4)
H3	IP20	5.5–7.5 (7.5–10)	0.8 (7)	0.8 (7)	0.8 (7)	0.5 (4)	0.8 (7)	0.5 (4)
H4	IP20	11–15 (15–20)	1.2 (11)	1.2 (11)	1.2 (11)	0.5 (4)	0.8 (7)	0.5 (4)
H5	IP20	18.5–22 (25–30)	1.2 (11)	1.2 (11)	1.2 (11)	0.5 (4)	0.8 (7)	0.5 (4)
H6	IP20	30–45 (40–60)	4.5 (40)	4.5 (40)	–	0.5 (4)	3 (27)	0.5 (4)
H7	IP20	55 (70)	10 (89)	10 (89)	–	0.5 (4)	3 (27)	0.5 (4)
H7	IP20	75 (100)	14 (124)	14 (124)	–	0.5 (4)	3 (27)	0.5 (4)
H8	IP20	90 (125)	24 (212) ¹⁾	24 (212) ¹⁾	–	0.5 (4)	3 (27)	0.5 (4)

Table 3.3 Tightening Torques for Enclosure Sizes H1–H8, 3x380–480 V

1) Cable dimensions >95 mm²

3.2.2 IT Mains

CAUTION

IT Mains

Installation on isolated mains source, that is, IT mains. Ensure that the supply voltage does not exceed 440 V (3x380–480 V units) when connected to mains.

For 380–480 V, IP20, 0.37–22 kW (0.5–30 hp) units, open the RFI switch by removing the screw on the side of the frequency converter when at IT grid.

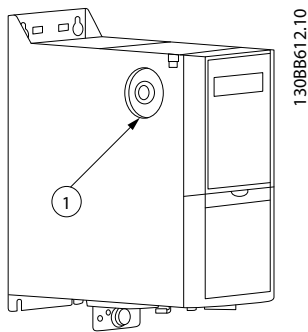

1	EMC screw
---	-----------

Illustration 3.1 IP20, 0.37–22 kW (0.5–30 hp), 380–480 V

For 380–480 V, 30–90 kW units, set *parameter 14-50 RFI Filter* to [0] Off when operating in IT mains.

NOTICE

If reinserted, use only M3x12 screw.

3.2.3 Connecting to Mains and Motor

The frequency converter is designed to operate all standard 3-phase asynchronous motors. For maximum cross-section on cables, see *chapter 7.4 General Technical Data*.

- Use a shielded/armored motor cable to comply with EMC emission specifications, and connect this cable to both the decoupling plate and the motor.
- Keep the motor cable as short as possible to reduce the noise level and leakage currents.
- For further details on mounting the decoupling plate, see *VLT® HVAC Basic Drive FC 101 Decoupling Plate Mounting Instruction*.
- Also see *chapter 3.2.5 EMC-correct Electrical Installation*.

1. Mount the ground cables to the ground terminal.
2. Connect the motor to terminals U, V, and W, and tighten the screws according to the torques specified in *chapter 3.2.1 Electrical Installation in General*.
3. Connect the mains supply to terminals L1, L2, and L3, and tighten the screws according to the torques specified in *chapter 3.2.1 Electrical Installation in General*.

Relays and terminals on enclosure sizes H1–H5

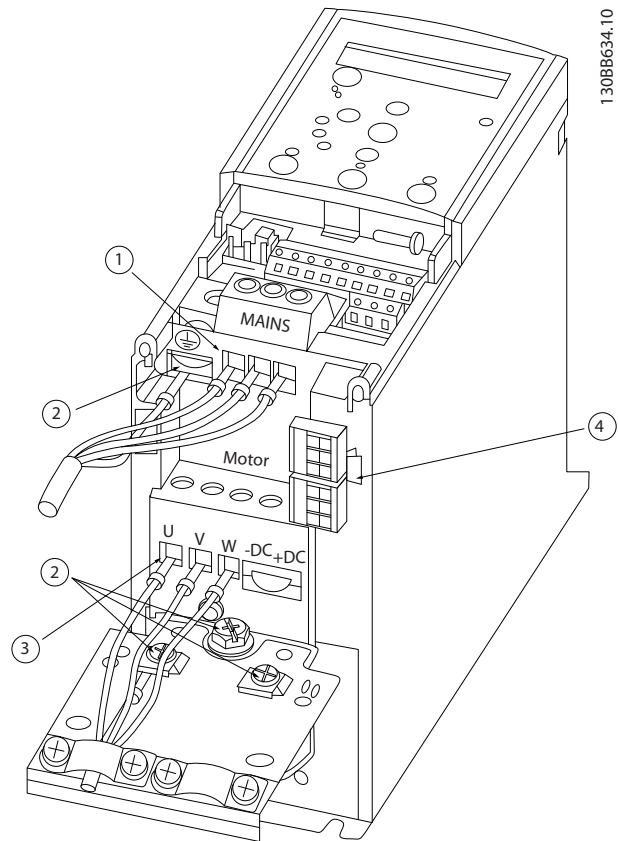

1	Mains
2	Ground
3	Motor
4	Relays

Illustration 3.2 Enclosure Sizes H1–H5
IP20, 380–480 V, 0.37–22 kW (0.5–30 hp)

3

Relays and terminals on enclosure size H6

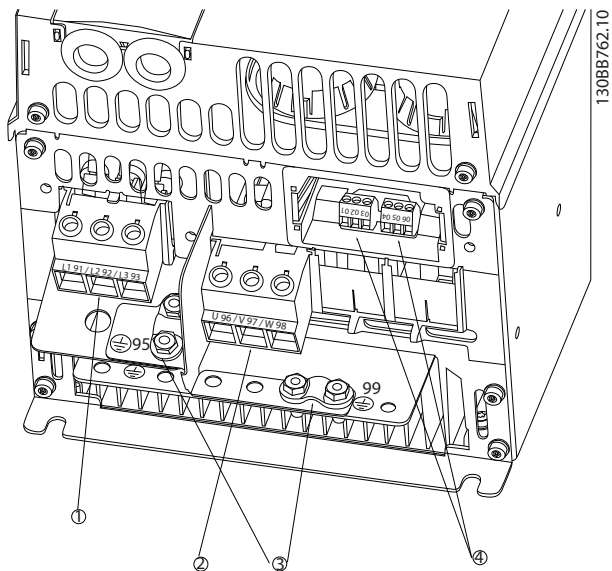

1	Mains
2	Motor
3	Ground
4	Relays

Illustration 3.3 Enclosure Size H6
IP20, 380–480 V, 30–45 kW (40–60 hp)

Relays and terminals on enclosure size H7

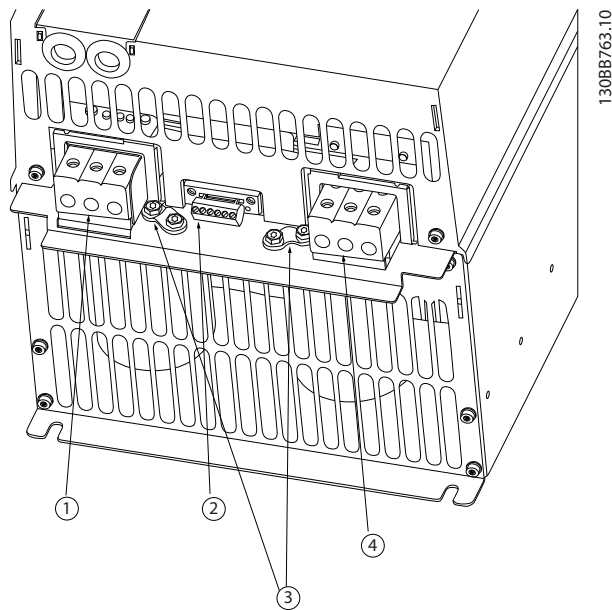

1	Mains
2	Relays
3	Ground
4	Motor

Illustration 3.4 Enclosure Size H7
IP20, 380–480 V, 55–75 kW (70–100 hp)

Relays and terminals on enclosure size H8

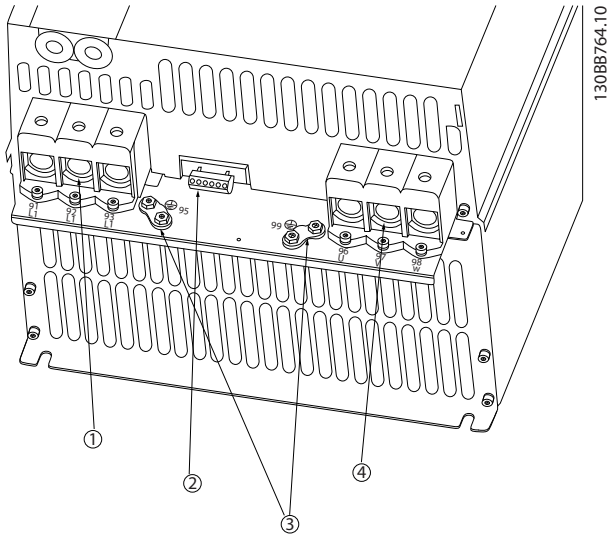

1	Mains
2	Relays
3	Ground
4	Motor

Illustration 3.5 Enclosure Size H8
IP20, 380–480 V, 90 kW (125 hp)

3.2.4 Fuses and Circuit Breakers

Branch circuit protection

To protect the installation against electrical and fire hazards, protect all branch circuits in an installation, switch gear, machines, and so on, against short circuit and overcurrent according to national and local regulations.

Short-circuit protection

To protect service personnel or other equipment if an internal failure in the unit or short circuit on DC-link occurs, Danfoss recommends using the fuses and circuit breakers listed in *Table 3.4*. The frequency converter provides full protection against short-circuit on the motor.

Overcurrent protection

Provide overload protection to avoid overheating of the cables in the installation. Carry out overcurrent protection according to local and national regulations. Design circuit breakers and fuses for protection in a circuit capable of supplying a maximum of 100000 A_{rms} (symmetrical), 480 V maximum.

UL/non-UL compliance

Use the circuit breakers or fuses listed in *Table 3.4*, to ensure compliance with UL or IEC 61800-5-1.

Design circuit breakers for protection in a circuit capable of supplying a maximum of 10000 A_{rms} (symmetrical), 480 V maximum.



If malfunction occurs, failure to follow the protection recommendation may result in damage to the frequency converter.

	Circuit breaker		Fuse				
	UL	Non-UL	UL				Non-UL
			Bussmann Type RK5	Bussmann Type RK1	Bussmann Type J	Bussmann Type T	Maximum fuse Type G
Power [kW(hp)]	-						
3x380-480 V IP20							
0.37 (0.5)	-		FRS-R-10	KTS-R10	JKS-10	JJS-10	10
0.75 (1)	-		FRS-R-10	KTS-R10	JKS-10	JJS-10	10
1.5 (2)	-		FRS-R-10	KTS-R10	JKS-10	JJS-10	10
2.2 (3)	-		FRS-R-15	KTS-R15	JKS-15	JJS-15	16
3 (4)	-		FRS-R-15	KTS-R15	JKS-15	JJS-15	16
4 (5)	-		FRS-R-15	KTS-R15	JKS-15	JJS-15	16
5.5 (7.5)	-		FRS-R-25	KTS-R25	JKS-25	JJS-25	25
7.5 (10)	-		FRS-R-25	KTS-R25	JKS-25	JJS-25	25
11 (15)	-		FRS-R-50	KTS-R50	JKS-50	JJS-50	50
15 (20)	-		FRS-R-50	KTS-R50	JKS-50	JJS-50	50
18.5 (25)	-		FRS-R-80	KTS-R80	JKS-80	JJS-80	65
22 (30)	-		FRS-R-80	KTS-R80	JKS-80	JJS-80	65
30 (40)	Cutler-Hammer EGE3125FFG	Moeller NZMB1- A125	FRS-R-125	KTS-R125	JKS-R125	JJS-R125	80
37 (50)			FRS-R-125	KTS-R125	JKS-R125	JJS-R125	100
45 (60)			FRS-R-125	KTS-R125	JKS-R125	JJS-R125	125
55 (70)	Cutler-Hammer JGE3200FFG	Moeller NZMB1- A200	FRS-R-200	KTS-R200	JKS-R200	JJS-R200	150
75 (100)			FRS-R-200	KTS-R200	JKS-R200	JJS-R200	200
90 (125)	Cutler-Hammer JGE3250FFG	Moeller NZMB2- A250	FRS-R-250	KTS-R250	JKS-R250	JJS-R250	250

Table 3.4 Circuit Breakers and Fuses

3.2.5 EMC-correct Electrical Installation

General points to be observed to ensure EMC-correct electrical installation:

- Use only screened/armoured motor cables and screened/armoured control cables.
- Ground the screen at both ends.
- Avoid installation with twisted screen ends (pigtails), because it reduces the screening effect at high frequencies. Use the cable clamps provided.
- Ensure the same potential between the frequency converter and the ground potential of PLC.
- Use star washers and galvanically conductive installation plates.

3

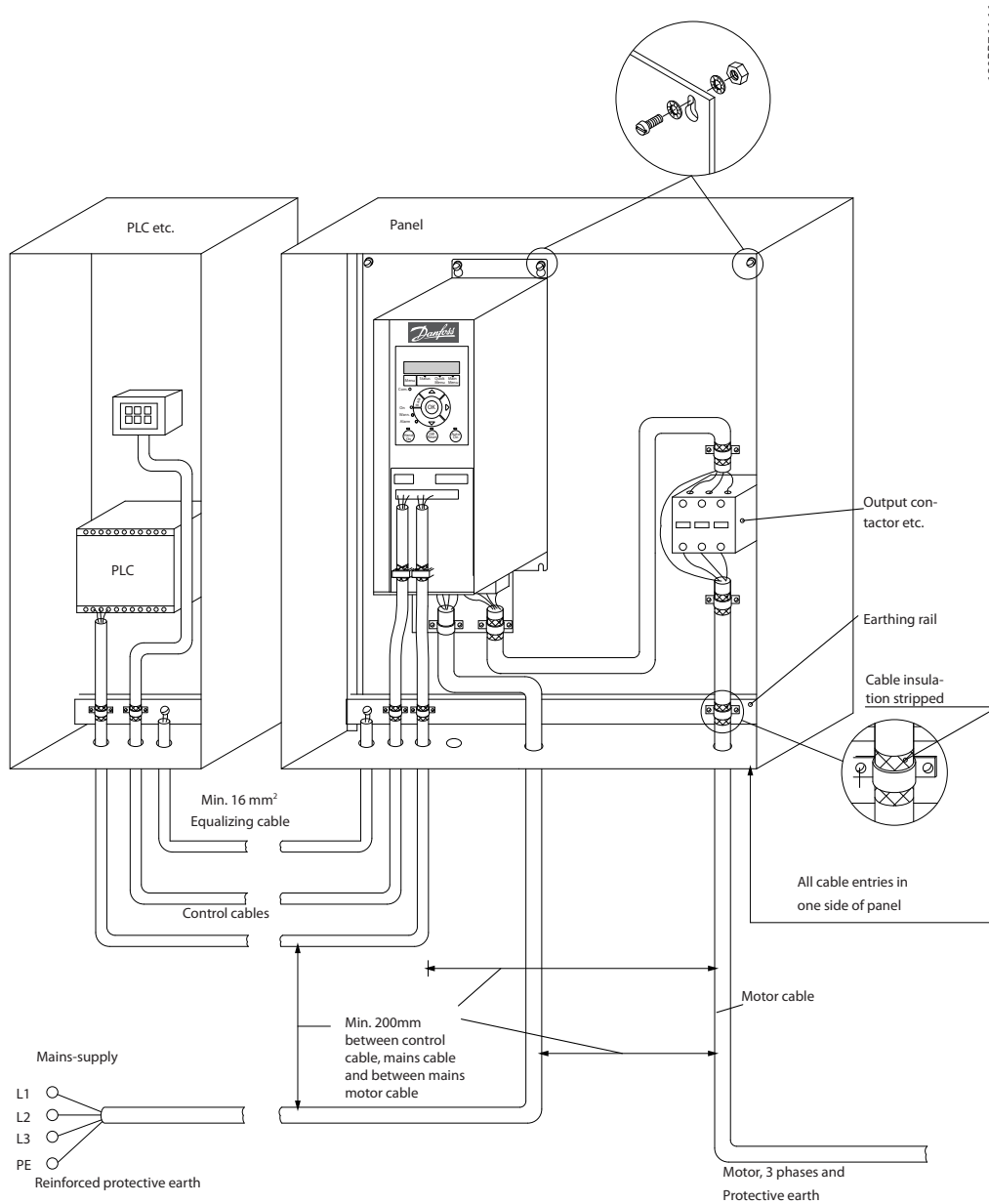

Illustration 3.6 EMC-correct Electrical Installation

3.2.6 Control Terminals

Remove the terminal cover to access the control terminals.

Use a flat-edged screwdriver to push down the lock lever of the terminal cover under the LCP, then remove the terminal cover, as shown in *Illustration 3.7*.

3

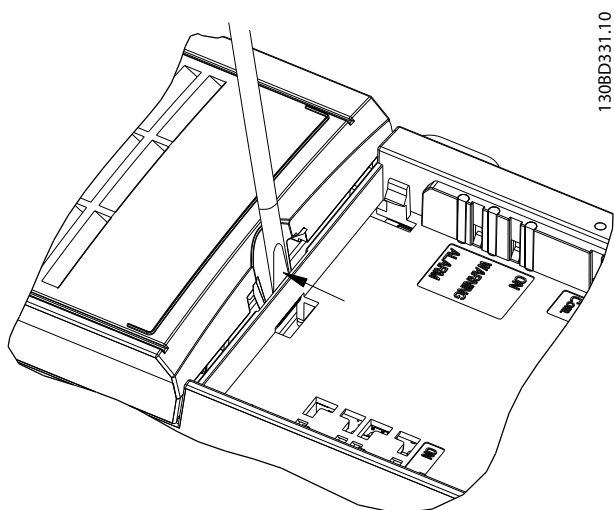

Illustration 3.7 Removing the Terminal Cover

Illustration 3.8 shows all the frequency converter control terminals. Applying start (terminal 18), connection between terminals 12–27, and an analog reference (terminal 53 or 54 and 55) make the frequency converter run.

The digital input mode of terminal 18, 19, and 27 is set in *parameter 5-00 Digital Input Mode* (PNP is default value). The digital input mode for terminal 29 is set in *parameter 5-03 Digital Input 29 Mode* (PNP is default value).

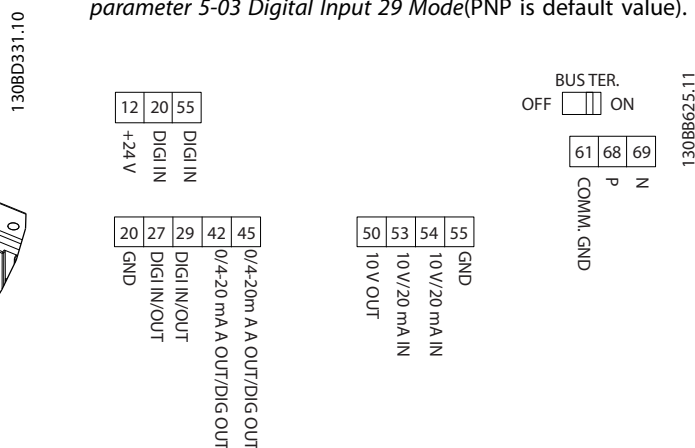

Illustration 3.8 Control Terminals

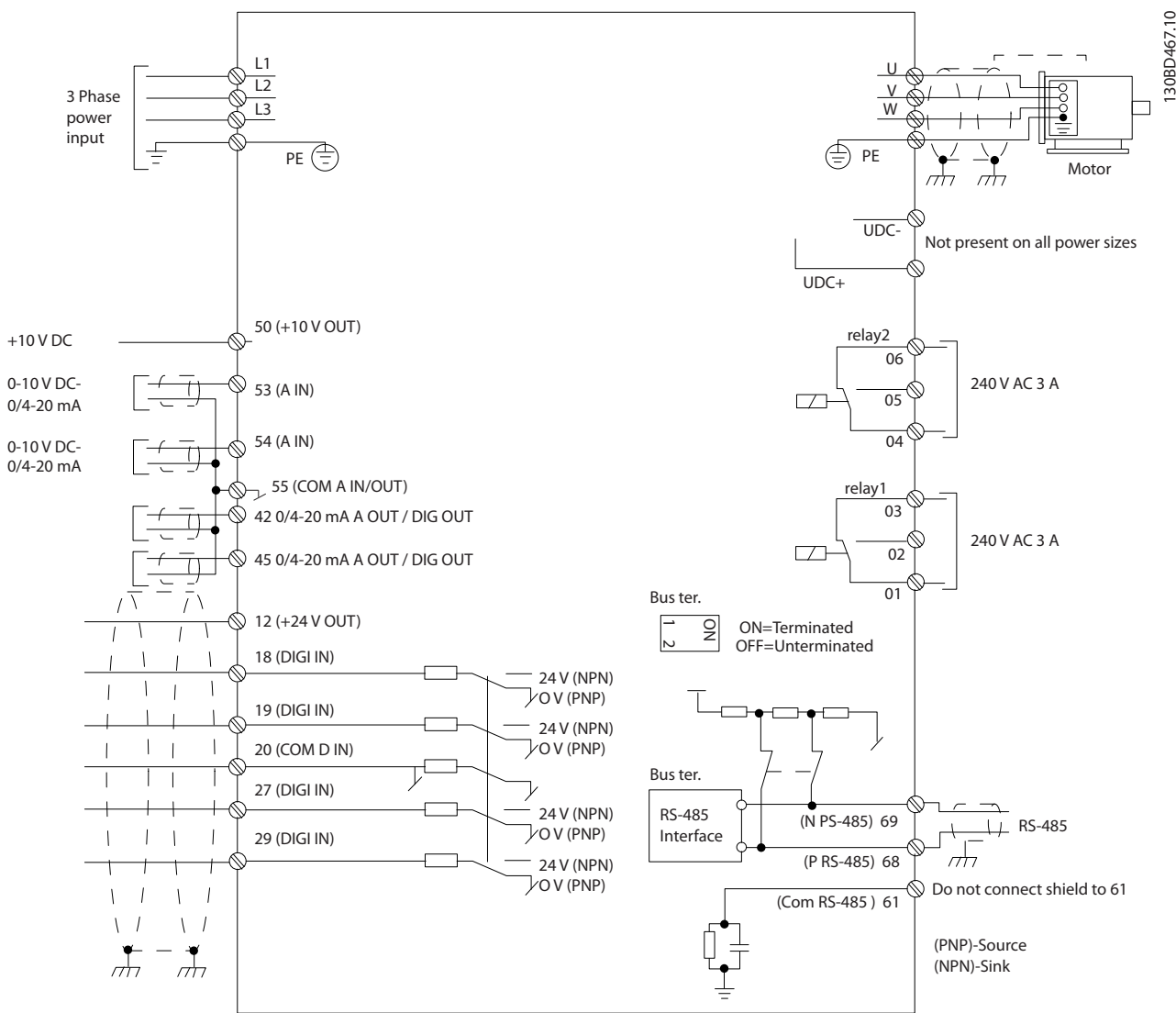

Illustration 3.9 Basic Wiring Schematic Drawing

NOTICE

There is no access to UDC- and UDC+ on the following units:

- IP20, 380–480 V, 30–90 kW (40–125 hp)

3.2.7 Acoustic Noise or Vibration

If the motor or the equipment driven by the motor - for example, a fan - is making noise or vibrations at certain frequencies, configure the following parameters or parameter groups to reduce or eliminate the noise or vibrations:

3

- Parameter group *4-6* Speed Bypass*.
- Set *parameter 14-03 Overmodulation* to *[0] Off*.
- Switching pattern and switching frequency parameter group *14-0* Inverter Switching*.
- *Parameter 1-64 Resonance Dampening*.

4 Programming

4.1 Local Control Panel (LCP)

The frequency converter can be programmed from the LCP, or from a PC via the RS485 COM port by installing the MCT 10 Set-up Software. Refer to *chapter 1.2 Additional Resources* for more details about the software.

The LCP is divided into 4 functional sections.

- A. Display
- B. Menu key
- C. Navigation keys and indicator lights
- D. Operation keys and indicator lights

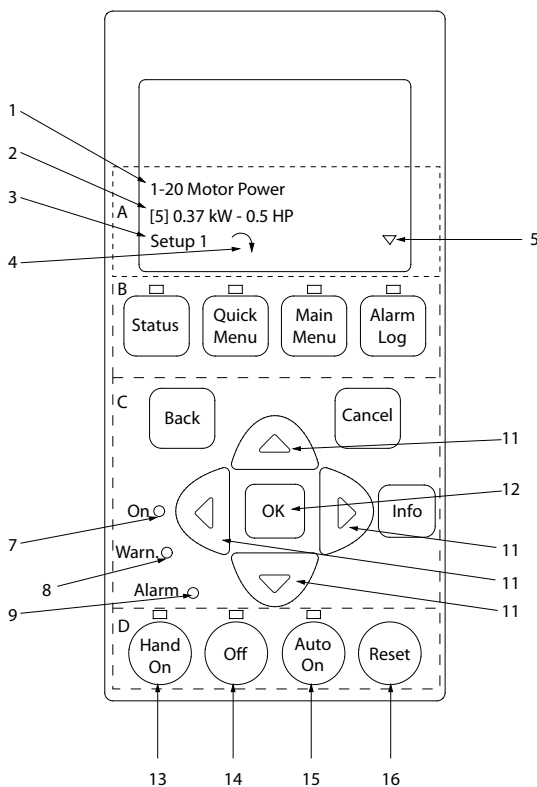

130BB765.12

Illustration 4.1 Local Control Panel (LCP)

A. Display

The LCD-display is illuminated with 2 alphanumeric lines. All data is displayed on the LCP.

Illustration 4.1 describes the information that can be read from the display.

1	Parameter number and name.
2	Parameter value.
3	Set-up number shows the active set-up and the edit set-up. If the same set-up acts as both active and edit set-up, only that set-up number is shown (factory setting). When active and edit set-up differ, both numbers are shown in the display (set-up 12). The number flashing, indicates the edit set-up.
4	Motor direction is shown to the bottom left of the display – indicated by a small arrow pointing either clockwise or counterclockwise.
5	The triangle indicates if the LCP is in <i>Status</i> , <i>Quick Menu</i> , or <i>Main Menu</i> .

Table 4.1 Legend to Illustration 4.1, Part I

B. Menu key

Press [Menu] to select among *Status*, *Quick Menu*, or *Main Menu*.

C. Navigation keys and indicator lights

6	Com. LED: Flashes when bus communication is communicating.
7	Green LED/On: Control section is working correctly.
8	Yellow LED/Warn.: Indicates a warning.
9	Flashing Red LED/Alarm: Indicates an alarm.
10	[Back]: For moving to the previous step or layer in the navigation structure.
11	[▲] [▼] [▶]: For navigating among parameter groups and parameters, as well as within parameters. They can also be used for setting local reference.
12	[OK]: For selecting a parameter and for accepting changes to parameter settings.

Table 4.2 Legend to Illustration 4.1, Part II

D. Operation keys and indicator lights

13	[Hand On]: Starts the motor and enables control of the frequency converter via the LCP. NOTICE [2] coast inverse is the default option for parameter 5-12 Terminal 27 Digital Input. If there is no 24 V supply to terminal 27, [Hand On] does not start the motor. Connect terminal 12 to terminal 27.
14	[Off/Reset]: Stops the motor (Off). If in alarm mode, the alarm is reset.
15	[Auto On]: The frequency converter is controlled either via control terminals or serial communication.

Table 4.3 Legend to Illustration 4.1, Part III

4

4.2 Set-up Wizard

The built-in wizard menu guides the installer through the set-up of the frequency converter in a clear and structured manner for open-loop and closed-loop applications, and quick motor settings.

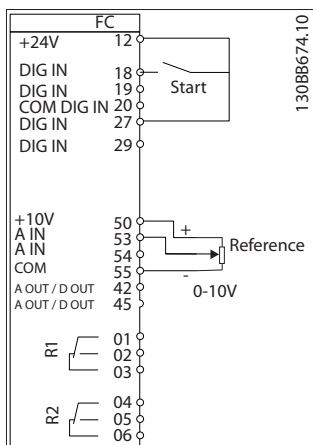

Illustration 4.2 Frequency Converter Wiring

The wizard is displayed after power-up until any parameter has been changed. The wizard can always be accessed again through the quick menu. Press [OK] to start the wizard. Press [Back] to return to the status view.

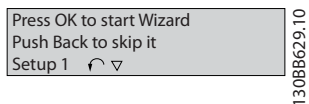
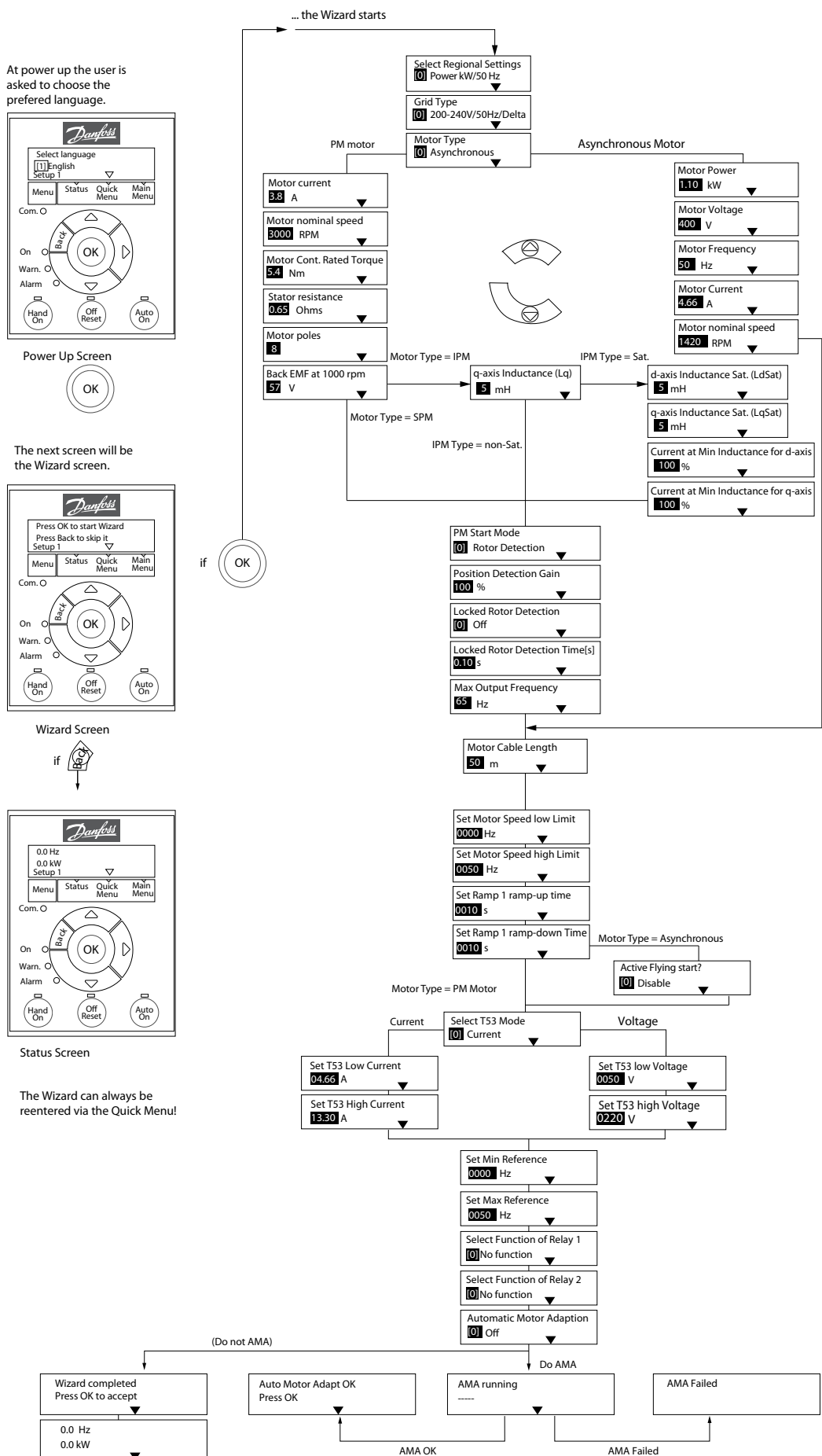
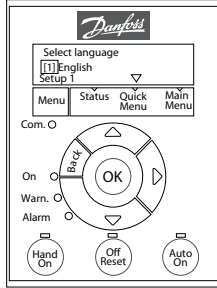

Illustration 4.3 Start-up/Quit Wizard



At power up the user is asked to choose the preferred language.



Power Up Screen



The next screen will be the Wizard screen.

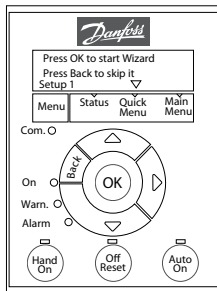

Wizard Screen

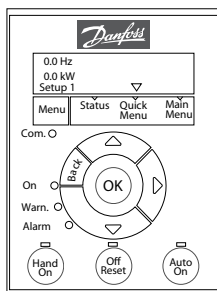

Status Screen

The Wizard can always be reentered via the Quick Menu!

Illustration 4.4 Set-up Wizard for Open-loop Applications

Parameter 1-46 Position Detection Gain and parameter 1-70 PM Start Mode are available in software version 2.80 and subsequent versions.

Set-up Wizard for Open-loop Applications

4

Parameter	Option	Default	Usage
Parameter 0-03 Regional Settings	[0] International [1] US	[0] International	
Parameter 0-06 GridType	[0] 200–240 V/50 Hz/IT-grid [1] 200–240 V/50 Hz/Delta [2] 200–240 V/50 Hz [10] 380–440 V/50 Hz/IT-grid [11] 380–440 V/50 Hz/Delta [12] 380–440 V/50 Hz [20] 440–480 V/50 Hz/IT-grid [21] 440–480 V/50 Hz/Delta [22] 440–480 V/50 Hz [30] 525–600 V/50 Hz/IT-grid [31] 525–600 V/50 Hz/Delta [32] 525–600 V/50 Hz [100] 200–240 V/60 Hz/IT-grid [101] 200–240 V/60 Hz/Delta [102] 200–240 V/60 Hz [110] 380–440 V/60 Hz/IT-grid [111] 380–440 V/60 Hz/Delta [112] 380–440 V/60 Hz [120] 440–480 V/60 Hz/IT-grid [121] 440–480 V/60 Hz/Delta [122] 440–480 V/60 Hz [130] 525–600 V/60 Hz/IT-grid [131] 525–600 V/60 Hz/Delta [132] 525–600 V/60 Hz	Size related	Select the operating mode for restart after reconnection of the frequency converter to mains voltage after power down.

Parameter	Option	Default	Usage
Parameter 1-10 Motor Construction	*[0] Asynchron [1] PM, non-salient SPM [2] PM, salient IPM, non Sat. [3] PM, salient IPM, Sat.	[0] Asynchron	Setting the parameter value might change these parameters: <ul style="list-style-type: none"> • Parameter 1-01 Motor Control Principle. • Parameter 1-03 Torque Characteristics. • Parameter 1-08 Motor Control Bandwidth. • Parameter 1-14 Damping Gain. • Parameter 1-15 Low Speed Filter Time Const.. • Parameter 1-16 High Speed Filter Time Const.. • Parameter 1-17 Voltage filter time const.. • Parameter 1-20 Motor Power. • Parameter 1-22 Motor Voltage. • Parameter 1-23 Motor Frequency. • Parameter 1-24 Motor Current. • Parameter 1-25 Motor Nominal Speed. • Parameter 1-26 Motor Cont. Rated Torque. • Parameter 1-30 Stator Resistance (Rs). • Parameter 1-33 Stator Leakage Reactance (X1). • Parameter 1-35 Main Reactance (Xh). • Parameter 1-37 d-axis Inductance (Ld). • Parameter 1-38 q-axis Inductance (Lq). • Parameter 1-39 Motor Poles. • Parameter 1-40 Back EMF at 1000 RPM. • Parameter 1-44 d-axis Inductance Sat. (LdSat). • Parameter 1-45 q-axis Inductance Sat. (LqSat). • Parameter 1-46 Position Detection Gain. • Parameter 1-48 Current at Min Inductance for d-axis. • Parameter 1-49 Current at Min Inductance for q-axis. • Parameter 1-66 Min. Current at Low Speed. • Parameter 1-70 PM Start Mode. • Parameter 1-72 Start Function. • Parameter 1-73 Flying Start. • Parameter 1-80 Function at Stop. • Parameter 1-82 Min Speed for Function at Stop [Hz]. • Parameter 1-90 Motor Thermal Protection. • Parameter 2-00 DC Hold/Motor Preheat Current. • Parameter 2-01 DC Brake Current. • Parameter 2-02 DC Braking Time. • Parameter 2-04 DC Brake Cut In Speed. • Parameter 2-10 Brake Function. • Parameter 4-14 Motor Speed High Limit [Hz]. • Parameter 4-19 Max Output Frequency. • Parameter 4-58 Missing Motor Phase Function. • Parameter 14-65 Speed Derate Dead Time Compensation.

Parameter	Option	Default	Usage
Parameter 1-20 Motor Power	0.12–110 kW/0.16–150 hp	Size related	Enter the motor power from the nameplate data.
Parameter 1-22 Motor Voltage	50–1000 V	Size related	Enter the motor voltage from the nameplate data.
Parameter 1-23 Motor Frequency	20–400 Hz	Size related	Enter the motor frequency from the nameplate data.
Parameter 1-24 Motor Current	0.01–10000.00 A	Size related	Enter the motor current from the nameplate data.
Parameter 1-25 Motor Nominal Speed	50–9999 RPM	Size related	Enter the motor nominal speed from the nameplate data.
Parameter 1-26 Motor Cont. Rated Torque	0.1–1000.0 Nm	Size related	This parameter is available when <i>parameter 1-10 Motor Construction</i> is set to options that enable permanent motor mode. NOTICE Changing this parameter affects the settings of other parameters.
Parameter 1-29 Automatic Motor Adaption (AMA)	See <i>parameter 1-29 Automatic Motor Adaption (AMA)</i> .	Off	Performing an AMA optimises motor performance.
Parameter 1-30 Stator Resistance (Rs)	0.000–99.990 Ohm	Size related	Set the stator resistance value.
Parameter 1-37 d-axis Inductance (Ld)	0.000–1000.000 mH	Size related	Enter the value of the d-axis inductance. Obtain the value from the permanent magnet motor datasheet. The d-axis inductance cannot be found by performing an AMA.
Parameter 1-38 q-axis Inductance (Lq)	0.000–1000.000 mH	Size related	Enter the value of the q-axis inductance.
Parameter 1-39 Motor Poles	2–100	4	Enter the number of motor poles.
Parameter 1-40 Back EMF at 1000 RPM	10–9000 V	Size related	Line-line RMS back EMF voltage at 1000 RPM.
Parameter 1-42 Motor Cable Length	0–100 m	50 m	Enter the motor cable length.
Parameter 1-44 d-axis Inductance Sat. (LdSat)	0.000–1000.000 mH	Size related	This parameter corresponds to the inductance saturation of Ld. Ideally, this parameter has the same value as <i>parameter 1-37 d-axis Inductance (Ld)</i> . However, if the motor supplier provides an induction curve, enter the induction value, which is 200% of the nominal current.
Parameter 1-45 q-axis Inductance Sat. (LqSat)	0.000–1000.000 mH	Size related	This parameter corresponds to the inductance saturation of Lq. Ideally, this parameter has the same value as <i>parameter 1-38 q-axis Inductance (Lq)</i> . However, if the motor supplier provides an induction curve, enter the induction value, which is 200% of the nominal current.
Parameter 1-46 Position Detection Gain	20–200%	100%	Adjusts the height of the test pulse during position detection at start (valid from software version 2.80).
Parameter 1-48 Current at Min Inductance for d-axis	20–200%	100%	Enter the inductance saturation point.
Parameter 1-49 Current at Min Inductance for q-axis	20–200%	100%	This parameter specifies the saturation curve of the d- and q-inductance values. From 20% to 100% of this parameter, the inductances are linearly approximated due to parameters <i>parameter 1-37 d-axis Inductance (Ld)</i> , <i>parameter 1-38 q-axis Inductance (Lq)</i> , <i>parameter 1-44 d-axis Inductance Sat. (LdSat)</i> , and <i>parameter 1-45 q-axis Inductance Sat. (LqSat)</i> .

Parameter	Option	Default	Usage
Parameter 1-70 PM Start Mode	[0] Rotor Detection [1] Parking	[0] Rotor Detection	Valid from software version 2.80.
Parameter 1-73 Flying Start	[0] Disabled [0] Disabled	[0] Disabled	Select [1] Enabled to enable the frequency converter to catch a motor spinning due to mains drop-out. Select [0] Disabled if this function is not required. When this parameter is set to [1] Enabled, parameter 1-71 Start Delay and parameter 1-72 Start Function are not functional. Parameter 1-73 Flying Start is active in VVC ⁺ mode only.
Parameter 3-02 Minimum Reference	-4999.000–4999.000	0	The minimum reference is the lowest value obtainable by summing all references.
Parameter 3-03 Maximum Reference	-4999.000–4999.000	50	The maximum reference is the lowest obtainable by summing all references.
Parameter 3-41 Ramp 1 Ramp Up Time	0.05–3600.00 s	Size related	If asynchronous motor is selected, the ramp-up time is from 0 to rated parameter 1-23 Motor Frequency; if PM motor is selected, the ramp-up time is from 0 to parameter 1-25 Motor Nominal Speed.
Parameter 3-42 Ramp 1 Ramp Down Time	0.05–3600.00 s	Size related	For asynchronous motors, the ramp-down time is from rated parameter 1-23 Motor Frequency to 0; For PM motors, the ramp-down time is from parameter 1-25 Motor Nominal Speed to 0.
Parameter 4-12 Motor Speed Low Limit [Hz]	0.0–400.0 Hz	0 Hz	Enter the minimum limit for low speed.
Parameter 4-14 Motor Speed High Limit [Hz]	0.0–400.0 Hz	100 Hz	Enter the maximum limit for high speed.
Parameter 4-19 Max Output Frequency	0.0–400.0 Hz	100 Hz	Enter the maximum output frequency value.
Parameter 5-40 Function Relay	See parameter 5-40 Function Relay.	[9] Alarm	Select the function to control output relay 1.
Parameter 5-40 Function Relay	See parameter 5-40 Function Relay.	[5] Drive running	Select the function to control output relay 2.
Parameter 6-10 Terminal 53 Low Voltage	0.00–10.00 V	0.07 V	Enter the voltage that corresponds to the low reference value.
Parameter 6-11 Terminal 53 High Voltage	0.00–10.00 V	10 V	Enter the voltage that corresponds to the high reference value.
Parameter 6-12 Terminal 53 Low Current	0.00–20.00 mA	4 mA	Enter the current that corresponds to the low reference value.
Parameter 6-13 Terminal 53 High Current	0.00–20.00 mA	20 mA	Enter the current that corresponds to the high reference value.
Parameter 6-19 Terminal 53 mode	[0] Current [1] Voltage	[1] Voltage	Select if terminal 53 is used for current or voltage input.
Parameter 30-22 Locked Rotor Detection	[0] Off [1] On	[0] Off	–
Parameter 30-23 Locked Rotor Detection Time [s]	0.05–1 s	0.10 s	–

Table 4.4 Set-up Wizard for Open-loop Applications

Set-up Wizard for Closed-loop Applications

4

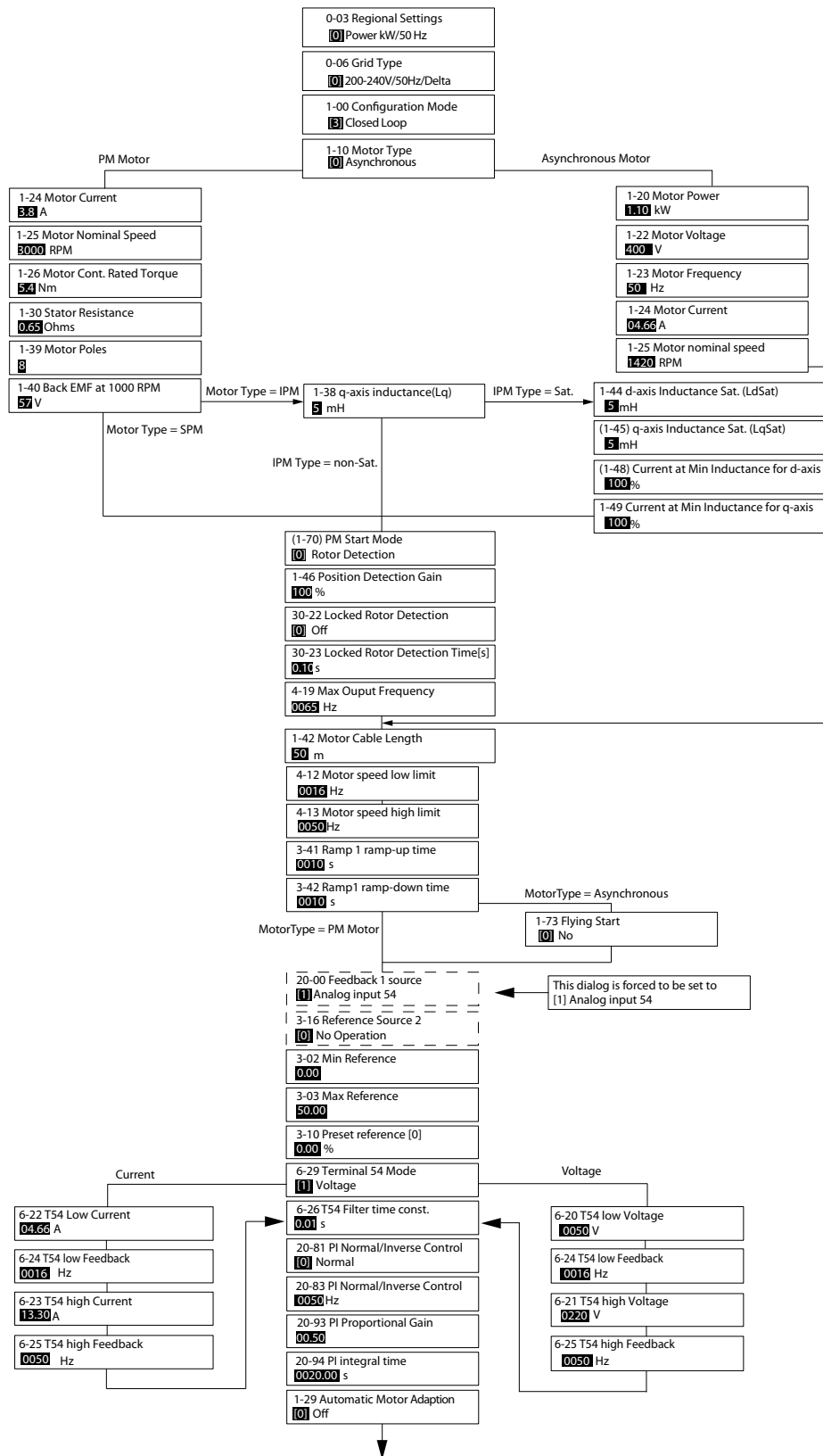

1308C402.11

Illustration 4.5 Set-up Wizard for Closed-loop Applications

Parameter 1-46 Position Detection Gain and parameter 1-70 PM Start Mode are available in software version 2.80 and subsequent versions.

Parameter	Range	Default	Usage
<i>Parameter 0-03 Regional Settings</i>	<i>[0] International [1] US</i>	<i>[0] International</i>	–
<i>Parameter 0-06 GridType</i>	<i>[0]–[132] see Table 4.4.</i>	<i>Size selected</i>	Select the operating mode for restart after reconnection of the frequency converter to mains voltage after power down.
<i>Parameter 1-00 Configuration Mode</i>	<i>[0] Open loop [3] Closed loop</i>	<i>[0] Open loop</i>	Select <i>[3] Closed loop</i> .

Parameter	Range	Default	Usage
Parameter 1-10 Motor Construction	<p>*[0] Asynchron</p> <p>[1] PM, non-salient SPM</p> <p>[2] PM, salient IPM, non Sat.</p> <p>[3] PM, salient IPM, Sat.</p>	[0] Asynchron	<p>Setting the parameter value might change these parameters:</p> <ul style="list-style-type: none"> • Parameter 1-01 Motor Control Principle. • Parameter 1-03 Torque Characteristics. • Parameter 1-08 Motor Control Bandwidth. • Parameter 1-14 Damping Gain. • Parameter 1-15 Low Speed Filter Time Const.. • Parameter 1-16 High Speed Filter Time Const.. • Parameter 1-17 Voltage filter time const.. • Parameter 1-20 Motor Power. • Parameter 1-22 Motor Voltage. • Parameter 1-23 Motor Frequency. • Parameter 1-24 Motor Current. • Parameter 1-25 Motor Nominal Speed. • Parameter 1-26 Motor Cont. Rated Torque. • Parameter 1-30 Stator Resistance (Rs). • Parameter 1-33 Stator Leakage Reactance (X1). • Parameter 1-35 Main Reactance (Xh). • Parameter 1-37 d-axis Inductance (Ld). • Parameter 1-38 q-axis Inductance (Lq). • Parameter 1-39 Motor Poles. • Parameter 1-40 Back EMF at 1000 RPM. • Parameter 1-44 d-axis Inductance Sat. (LdSat). • Parameter 1-45 q-axis Inductance Sat. (LqSat). • Parameter 1-46 Position Detection Gain. • Parameter 1-48 Current at Min Inductance for d-axis. • Parameter 1-49 Current at Min Inductance for q-axis. • Parameter 1-66 Min. Current at Low Speed. • Parameter 1-70 PM Start Mode. • Parameter 1-72 Start Function. • Parameter 1-73 Flying Start. • Parameter 1-80 Function at Stop. • Parameter 1-82 Min Speed for Function at Stop [Hz]. • Parameter 1-90 Motor Thermal Protection. • Parameter 2-00 DC Hold/Motor Preheat Current. • Parameter 2-01 DC Brake Current. • Parameter 2-02 DC Braking Time. • Parameter 2-04 DC Brake Cut In Speed. • Parameter 2-10 Brake Function. • Parameter 4-14 Motor Speed High Limit [Hz]. • Parameter 4-19 Max Output Frequency. • Parameter 4-58 Missing Motor Phase Function. • Parameter 14-65 Speed Derate Dead Time Compensation.

Parameter	Range	Default	Usage
Parameter 1-20 Motor Power	0.09–110 kW	Size related	Enter the motor power from the nameplate data.
Parameter 1-22 Motor Voltage	50–1000 V	Size related	Enter the motor voltage from the nameplate data.
Parameter 1-23 Motor Frequency	20–400 Hz	Size related	Enter the motor frequency from the nameplate data.
Parameter 1-24 Motor Current	0–10000 A	Size related	Enter the motor current from the nameplate data.
Parameter 1-25 Motor Nominal Speed	50–9999 RPM	Size related	Enter the motor nominal speed from the nameplate data.
Parameter 1-26 Motor Cont. Rated Torque	0.1–1000.0 Nm	Size related	This parameter is available when <i>parameter 1-10 Motor Construction</i> is set to options that enable permanent motor mode. NOTICE Changing this parameter affects the settings of other parameters.
Parameter 1-29 Automatic Motor Adaption (AMA)		Off	Performing an AMA optimises motor performance.
Parameter 1-30 Stator Resistance (Rs)	0–99.990 Ohm	Size related	Set the stator resistance value.
Parameter 1-37 d-axis Inductance (Ld)	0.000–1000.000 mH	Size related	Enter the value of the d-axis inductance. Obtain the value from the permanent magnet motor datasheet. The d-axis inductance cannot be found by performing an AMA.
Parameter 1-38 q-axis Inductance (Lq)	0.000–1000.000 mH	Size related	Enter the value of the q-axis inductance.
Parameter 1-39 Motor Poles	2–100	4	Enter the number of motor poles.
Parameter 1-40 Back EMF at 1000 RPM	10–9000 V	Size related	Line-line RMS back EMF voltage at 1000 RPM.
Parameter 1-42 Motor Cable Length	0–100 m	50 m	Enter the motor cable length.
Parameter 1-44 d-axis Inductance Sat. (LdSat)	0.000–1000.000 mH	Size related	This parameter corresponds to the inductance saturation of Ld. Ideally, this parameter has the same value as <i>parameter 1-37 d-axis Inductance (Ld)</i> . However, if the motor supplier provides an induction curve, enter the induction value, which is 200% of the nominal current.
Parameter 1-45 q-axis Inductance Sat. (LqSat)	0.000–1000.000 mH	Size related	This parameter corresponds to the inductance saturation of Lq. Ideally, this parameter has the same value as <i>parameter 1-38 q-axis Inductance (Lq)</i> . However, if the motor supplier provides an induction curve, enter the induction value, which is 200% of the nominal current.
Parameter 1-46 Position Detection Gain	20–200%	100%	Adjusts the height of the test pulse during position detection at start (valid from software version 2.80).
Parameter 1-48 Current at Min Inductance for d-axis	20–200%	100%	Enter the inductance saturation point.
Parameter 1-49 Current at Min Inductance for q-axis	20–200%	100%	This parameter specifies the saturation curve of the d- and q-inductance values. From 20% to 100% of this parameter, the inductances are linearly approximated due to parameters <i>parameter 1-37 d-axis Inductance (Ld)</i> , <i>parameter 1-38 q-axis Inductance (Lq)</i> , <i>parameter 1-44 d-axis Inductance Sat. (LdSat)</i> , and <i>parameter 1-45 q-axis Inductance Sat. (LqSat)</i> .
Parameter 1-70 PM Start Mode	[0] Rotor Detection [1] Parking	[0] Rotor Detection	Valid from software version 2.80.

Parameter	Range	Default	Usage
Parameter 1-73 Flying Start	[0] Disabled [1] Enabled	[0] Disabled	Select [1] Enabled to enable the frequency converter to catch a spinning motor in, for example, fan applications. When PM is selected, this parameter is enabled.
Parameter 3-02 Minimum Reference	-4999.000–4999.000	0	The minimum reference is the lowest value obtainable by summing all references.
Parameter 3-03 Maximum Reference	-4999.000–4999.000	50	The maximum reference is the highest value obtainable by summing all references.
Parameter 3-10 Preset Reference	-100–100%	0	Enter the setpoint.
Parameter 3-41 Ramp 1 Ramp Up Time	0.05–3600.0 s	Size related	Ramp-up time from 0 to rated <i>parameter 1-23 Motor Frequency</i> for asynchronous motors; ramp-up time from 0 to <i>parameter 1-25 Motor Nominal Speed</i> for PM motors.
Parameter 3-42 Ramp 1 Ramp Down Time	0.05–3600.0 s	Size related	Ramp-down time from rated <i>parameter 1-23 Motor Frequency</i> to 0 for asynchronous motors; ramp-down time from <i>parameter 1-25 Motor Nominal Speed</i> to 0 for PM motors.
Parameter 4-12 Motor Speed Low Limit [Hz]	0.0–400.0 Hz	0.0 Hz	Enter the minimum limit for low speed.
Parameter 4-14 Motor Speed High Limit [Hz]	0.0–400.0 Hz	100 Hz	Enter the minimum limit for high speed.
Parameter 4-19 Max Output Frequency	0.0–400.0 Hz	100 Hz	Enter the maximum output frequency value.
Parameter 6-20 Terminal 54 Low Voltage	0.00–10.00 V	0.07 V	Enter the voltage that corresponds to the low reference value.
Parameter 6-21 Terminal 54 High Voltage	0.00–10.00 V	10.00 V	Enter the voltage that corresponds to the high reference value.
Parameter 6-22 Terminal 54 Low Current	0.00–20.00 mA	4.00 mA	Enter the current that corresponds to the low reference value.
Parameter 6-23 Terminal 54 High Current	0.00–20.00 mA	20.00 mA	Enter the current that corresponds to the high reference value.
Parameter 6-24 Terminal 54 Low Ref./Feedb. Value	-4999–4999	0	Enter the feedback value that corresponds to the voltage or current set in <i>parameter 6-20 Terminal 54 Low Voltage/parameter 6-22 Terminal 54 Low Current</i> .
Parameter 6-25 Terminal 54 High Ref./Feedb. Value	-4999–4999	50	Enter the feedback value that corresponds to the voltage or current set in <i>parameter 6-21 Terminal 54 High Voltage/parameter 6-23 Terminal 54 High Current</i> .
Parameter 6-26 Terminal 54 Filter Time Constant	0.00–10.00 s	0.01	Enter the filter time constant.
Parameter 6-29 Terminal 54 mode	[0] Current [1] Voltage	[1] Voltage	Select if terminal 54 is used for current or voltage input.
Parameter 20-81 PI Normal/Inverse Control	[0] Normal [1] Inverse	[0] Normal	Select [0] Normal to set the process control to increase the output speed when the process error is positive. Select [1] Inverse to reduce the output speed.
Parameter 20-83 PI Start Speed [Hz]	0–200 Hz	0 Hz	Enter the motor speed to be attained as a start signal for commencement of PI control.
Parameter 20-93 PI Proportional Gain	0.00–10.00	0.01	Enter the process controller proportional gain. Quick control is obtained at high amplification. However, if amplification is too high, the process may become unstable.
Parameter 20-94 PI Integral Time	0.1–999.0 s	999.0 s	Enter the process controller integral time. Obtain quick control through a short integral time, though if the integral time is too short, the process becomes unstable. An excessively long integral time disables the integral action.
Parameter 30-22 Locked Rotor Detection	[0] Off [1] On	[0] Off	–

Parameter	Range	Default	Usage
Parameter 30-23 Locked Rotor Detection Time [s]	0.05–1.00 s	0.10 s	–

Table 4.5 Set-up Wizard for Closed-loop Applications
Motor set-up

The motor set-up wizard guides users through the needed motor parameters.

Parameter	Range	Default	Usage
Parameter 0-03 Regional Settings	[0] International [1] US	0	–
Parameter 0-06 GridType	[0]–[132] see Table 4.4.	Size related	Select the operating mode for restart after reconnection of the frequency converter to mains voltage after power down.

Parameter	Range	Default	Usage
Parameter 1-10 Motor Construction	*[0] Asynchron [1] PM, non-salient SPM [2] PM, salient IPM, non Sat. [3] PM, salient IPM, Sat.	[0] Asynchron	Setting the parameter value might change these parameters: <ul style="list-style-type: none"> • Parameter 1-01 Motor Control Principle. • Parameter 1-03 Torque Characteristics. • Parameter 1-08 Motor Control Bandwidth. • Parameter 1-14 Damping Gain. • Parameter 1-15 Low Speed Filter Time Const.. • Parameter 1-16 High Speed Filter Time Const.. • Parameter 1-17 Voltage filter time const.. • Parameter 1-20 Motor Power. • Parameter 1-22 Motor Voltage. • Parameter 1-23 Motor Frequency. • Parameter 1-24 Motor Current. • Parameter 1-25 Motor Nominal Speed. • Parameter 1-26 Motor Cont. Rated Torque. • Parameter 1-30 Stator Resistance (Rs). • Parameter 1-33 Stator Leakage Reactance (X1). • Parameter 1-35 Main Reactance (Xh). • Parameter 1-37 d-axis Inductance (Ld). • Parameter 1-38 q-axis Inductance (Lq). • Parameter 1-39 Motor Poles. • Parameter 1-40 Back EMF at 1000 RPM. • Parameter 1-44 d-axis Inductance Sat. (LdSat). • Parameter 1-45 q-axis Inductance Sat. (LqSat). • Parameter 1-46 Position Detection Gain. • Parameter 1-48 Current at Min Inductance for d-axis. • Parameter 1-49 Current at Min Inductance for q-axis. • Parameter 1-66 Min. Current at Low Speed. • Parameter 1-70 PM Start Mode. • Parameter 1-72 Start Function. • Parameter 1-73 Flying Start. • Parameter 1-80 Function at Stop. • Parameter 1-82 Min Speed for Function at Stop [Hz]. • Parameter 1-90 Motor Thermal Protection. • Parameter 2-00 DC Hold/Motor Preheat Current. • Parameter 2-01 DC Brake Current. • Parameter 2-02 DC Braking Time. • Parameter 2-04 DC Brake Cut In Speed. • Parameter 2-10 Brake Function. • Parameter 4-14 Motor Speed High Limit [Hz]. • Parameter 4-19 Max Output Frequency. • Parameter 4-58 Missing Motor Phase Function. • Parameter 14-65 Speed Derate Dead Time Compensation.

Parameter	Range	Default	Usage
Parameter 1-20 Motor Power	0.12–110 kW/0.16–150 hp	Size related	Enter the motor power from the nameplate data.
Parameter 1-22 Motor Voltage	50–1000 V	Size related	Enter the motor voltage from the nameplate data.
Parameter 1-23 Motor Frequency	20–400 Hz	Size related	Enter the motor frequency from the nameplate data.
Parameter 1-24 Motor Current	0.01–10000.00 A	Size related	Enter the motor current from the nameplate data.
Parameter 1-25 Motor Nominal Speed	50–9999 RPM	Size related	Enter the motor nominal speed from the nameplate data.
Parameter 1-26 Motor Cont. Rated Torque	0.1–1000.0 Nm	Size related	This parameter is available when <i>parameter 1-10 Motor Construction</i> is set to options that enable permanent motor mode. NOTICE Changing this parameter affects the settings of other parameters.
Parameter 1-30 Stator Resistance (Rs)	0–99.990 Ohm	Size related	Set the stator resistance value.
Parameter 1-37 d-axis Inductance (Ld)	0.000–1000.000 mH	Size related	Enter the value of the d-axis inductance. Obtain the value from the permanent magnet motor datasheet. The d-axis inductance cannot be found by performing an AMA.
Parameter 1-38 q-axis Inductance (Lq)	0.000–1000.000 mH	Size related	Enter the value of the q-axis inductance.
Parameter 1-39 Motor Poles	2–100	4	Enter the number of motor poles.
Parameter 1-40 Back EMF at 1000 RPM	10–9000 V	Size related	Line-line RMS back EMF voltage at 1000 RPM.
Parameter 1-42 Motor Cable Length	0–100 m	50 m	Enter the motor cable length.
Parameter 1-44 d-axis Inductance Sat. (LdSat)	0.000–1000.000 mH	Size related	This parameter corresponds to the inductance saturation of Ld. Ideally, this parameter has the same value as <i>parameter 1-37 d-axis Inductance (Ld)</i> . However, if the motor supplier provides an induction curve, enter the induction value, which is 200% of the nominal current.
Parameter 1-45 q-axis Inductance Sat. (LqSat)	0.000–1000.000 mH	Size related	This parameter corresponds to the inductance saturation of Lq. Ideally, this parameter has the same value as <i>parameter 1-38 q-axis Inductance (Lq)</i> . However, if the motor supplier provides an induction curve, enter the induction value, which is 200% of the nominal current.
Parameter 1-46 Position Detection Gain	20–200%	100%	Adjusts the height of the test pulse during position detection at start (valid from software version 2.80).
Parameter 1-48 Current at Min Inductance for d-axis	20–200%	100%	Enter the inductance saturation point.
Parameter 1-49 Current at Min Inductance for q-axis	20–200%	100%	This parameter specifies the saturation curve of the d- and q-inductance values. From 20% to 100% of this parameter, the inductances are linearly approximated due to parameters <i>parameter 1-37 d-axis Inductance (Ld)</i> , <i>parameter 1-38 q-axis Inductance (Lq)</i> , <i>parameter 1-44 d-axis Inductance Sat. (LdSat)</i> , and <i>parameter 1-45 q-axis Inductance Sat. (LqSat)</i> .
Parameter 1-70 PM Start Mode	[0] Rotor Detection [1] Parking	[0] Rotor Detection	Valid from software version 2.80.
Parameter 1-73 Flying Start	[0] Disabled [1] Enabled	[0] Disabled	Select [1] Enabled to enable the frequency converter to catch a spinning motor.
Parameter 3-41 Ramp 1 Ramp Up Time	0.05–3600.0 s	Size related	Ramp-up time from 0 to rated <i>parameter 1-23 Motor Frequency</i> .

Parameter	Range	Default	Usage
Parameter 3-42 Ramp 1 Ramp Down Time	0.05–3600.0 s	Size related	Ramp-down time from rated parameter 1-23 Motor Frequency to 0.
Parameter 4-12 Motor Speed Low Limit [Hz]	0.0–400.0 Hz	0.0 Hz	Enter the minimum limit for low speed.
Parameter 4-14 Motor Speed High Limit [Hz]	0.0–400.0 Hz	100.0 Hz	Enter the maximum limit for high speed.
Parameter 4-19 Max Output Frequency	0.0–400.0 Hz	100.0 Hz	Enter the maximum output frequency value.
Parameter 30-22 Locked Rotor Detection	[0] Off [1] On	[0] Off	–
Parameter 30-23 Locked Rotor Detection Time [s]	0.05–1.00 s	0.10 s	–

Table 4.6 Motor Set-up Wizard Settings
Changes made

The *Changes Made* function lists all parameters changed from default settings.

- The list shows only parameters that have been changed in the current edit set-up.
- Parameters that have been reset to default values are not listed.
- The message *Empty* indicates that no parameters have been changed.

4.3 Parameter List
Changing parameter settings

1. Press the [Menu] key to enter the *Quick Menu* until the indicator in the display is placed above *Quick Menu*.
2. Press [▲] [▼] to select the wizard, closed-loop set-up, motor set-up, or changes made, then press [OK].
3. Press [▲] [▼] to browse through the parameters in the *Quick Menu*.
4. Press [OK] to select a parameter.
5. Press [▲] [▼] to change the value of a parameter setting.
6. Press [OK] to accept the change.
7. Press either [Back] twice to enter *Status*, or press [Menu] once to enter the *Main Menu*.

The main menu accesses all parameters

1. Press the [Menu] key until the indicator in the display is placed above *Main Menu*.
2. Press [▲] [▼] to browse through the parameter groups.
3. Press [OK] to select a parameter group.
4. Press [▲] [▼] to browse through the parameters in the specific group.
5. Press [OK] to select the parameter.
6. Press [▲] [▼] to set/change the parameter value.

0-0*	Operation / Display	1-44	d-axis Inductance Sat. (LdSat)	4-4*	Limits / Warnings	6-2*	Analog Input 54	8-84	Slave Messages Sent
0-0*	Basic Settings	1-45	q-axis Inductance Sat. (LqSat)	4-1*	Motor Limits	6-20	Terminal 54 Low Voltage	8-85	Slave Timeout Errors
0-01	Language	1-46	Position Detection Gain	4-10	Motor Speed Direction	6-21	Terminal 54 High Voltage	8-88	Reset FC port Diagnostics
0-03	Regional Settings	1-48	Current at Min Inductance for d-axis	4-12	Motor Speed Low Limit [Hz]	6-22	Terminal 54 Low Current	8-9*	Bus Feedback
0-04	Operating State at Power-up	1-49	Current at Min Inductance for q-axis	4-14	Motor Speed High Limit [Hz]	6-23	Terminal 54 High Current	8-94	Bus Feedback 1
0-06	GridType	1-5*	Load Indep. Setting	4-18	Current Limit	6-24	Terminal 54 Low Ref./Feedb. Value	8-95	Bus Feedback 2
0-07	Auto DC Braking	1-50	Motor Magnetisation at Zero Speed	4-19	Max Output Frequency	6-25	Terminal 54 High Ref./Feedb. Value	13-0*	Smart Logic
0-1*	Set-up Operations	1-52	Min Speed Normal Magnetising [Hz]	4-4*	Adj. Warnings 2	6-26	Terminal 54 Filter Time Constant	13-0*	SLC Settings
0-10	Active Set-up	1-55	U/f Characteristic - U	4-40	Warning Freq. Low	6-29	Terminal 54 mode	13-00	SL Controller Mode
0-11	Programming Set-up	1-56	U/f Characteristic - F	4-41	Warning Freq. High	6-7*	Terminal 54 mode	13-01	Start Event
0-12	Link Setups	1-5*	Load Depen. Setting	4-5*	Adj. Warnings	6-70	Analog/Digital Output 45	13-02	Stop Event
0-3*	LCP Custom Readout	1-62	Slip Compensation	4-50	Warning Current Low	6-71	Terminal 45 Analog Output	13-03	Reset SLC
0-30	Custom Readout Unit	1-63	Slip Compensation Time Constant	4-51	Warning Current High	6-72	Terminal 45 Digital Output	13-1*	Comparators
0-31	Custom Readout Min Value	1-64	Resonance Dampening	4-54	Warning Reference Low	6-73	Terminal 45 Output Min Scale	13-10	Comparator Operand
0-32	Custom Readout Max Value	1-65	Resonance Dampening Time Constant	4-55	Warning Reference High	6-74	Terminal 45 Output Max Scale	13-11	Comparator Operator
0-37	Display Text 1	1-66	Min. Current at Low Speed	4-56	Warning Feedback Low	6-9*	Terminal 42 Output Bus Control	13-12	Comparator Value
0-38	Display Text 2	1-7*	Start Adjustments	4-57	Warning Feedback High	6-9*	Analog/Digital Output 42	13-2*	Timers
0-39	Display Text 3	1-70	PM Start Mode	4-58	Missing Motor Phase Function	6-90	Terminal 42 Mode	13-20	SL Controller Timer
0-4*	LCP Keypad	1-71	Start Delay	4-6*	Speed Bypass	6-91	Terminal 42 Analog Output	13-4*	Logic Rules
0-40	[Hand on] Key on LCP	1-72	Start Function	4-61	Bypass Speed From [Hz]	6-92	Terminal 42 Digital Output	13-40	Logic Rule Boolean 1
0-42	[Auto on] Key on LCP	1-73	Flying Start	4-63	Bypass Speed To [Hz]	6-93	Terminal 42 Output Min Scale	13-41	Logic Rule Operator 1
0-44	[Off/Reset] Key on LCP	1-8*	Stop Adjustments	4-64	Semi-Auto Bypass Set-up	6-94	Terminal 42 Output Max Scale	13-42	Logic Rule Boolean 2
0-5*	Copy/Save	1-80	Function at Stop	5-*	Digital In/Out	6-96	Terminal 42 Output Bus Control	13-43	Logic Rule Operator 2
0-50	LCP Copy	1-82	Min. Speed for Function at Stop [Hz]	5-0*	Digital I/O mode	8-*	Comm. and Options	13-44	Logic Rule Boolean 3
0-51	Set-up Copy	1-9*	Motor Temperature	5-00	Digital Input Mode	8-0*	General Settings	13-5*	States
0-6*	Password	1-90	Motor Thermal Protection	5-03	Digital Input 29 Mode	8-01	Control Site	13-51	SL Controller Event
0-60	Main Menu Password	1-93	Thermistor Source	5-1*	Digital Inputs	8-02	Control Source	13-52	SL Controller Action
1-0*	Load and Motor	2-0*	Brakes	5-11	Terminal 18 Digital Input	8-03	Control Timeout Time	14-0*	Special Functions
1-00	Configuration Mode	2-00	DC Hold/Motor Preheat Current	5-10	Terminal 19 Digital Input	8-04	Control Timeout Function	14-0*	Inverter Switching
1-01	Motor Control Principle	2-01	DC Brake Current	5-12	Terminal 27 Digital Input	8-3*	FC Port Settings	14-01	Switching Frequency
1-03	Torque Characteristics	2-02	DC Braking Time	5-13	Terminal 29 Digital Input	8-30	Protocol	14-03	Overmodulation
1-06	Clockwise Direction	2-04	DC Brake Cut In Speed	5-3*	Digital Outputs	8-31	Address	14-08	Damping Gain Factor
1-08	Motor Control Bandwidth	2-06	Parking Current	5-34	On Delay, Digital Output	8-32	Baud Rate	14-09	Dead Time Bias Current Level
1-1*	Motor Selection	2-07	Parking Time	5-35	Off Delay, Digital Output	8-33	Parity / Stop Bits	14-1*	Mains On/Off
1-10	Motor Construction	2-1*	Brake Energy Funct.	5-40	Function Relay	8-35	Minimum Response Delay	14-10	Mains Failure
1-14	Damping Gain	2-10	Brake Function	5-41	On Delay, Relay	8-36	Maximum Response Delay	14-11	Mains Voltage at Mains Fault
1-15	Low Speed Filter Time Const	2-16	AC Brake, Max current	5-42	Off Delay, Relay	8-37	Maximum Inter-char delay	14-12	Function at Mains Imbalance
1-16	High Speed Filter Time Const	2-17	Over-voltage Control	5-5*	Pulse Input	8-4*	FC MC protocol set	14-2*	Reset Functions
1-17	Voltage filter time const	3-0*	Reference / Ramps	5-50	Term. 29 Low Frequency	8-42	PCD Write Configuration	14-20	Reset Mode
1-2*	Motor Data	3-0*	Reference Limits	5-50	Term. 29 High Frequency	8-43	PCD Read Configuration	14-21	Automatic Restart Time
1-20	Motor Power	3-02	Minimum Reference	5-51	Term. 29 High Frequency	8-5*	Digital/Bus	14-22	Operation Mode
1-22	Motor Voltage	3-03	Maximum Reference	5-52	Term. 29 Low Ref./Feedb. Value	8-50	Coasting Select	14-27	Action At Inverter Fault
1-23	Motor Frequency	3-1*	References	5-53	Term. 29 High Ref./Feedb. Value	8-51	Quick Stop Select	14-29	Service Code
1-24	Motor Current	3-10	Preset Reference	5-9*	Bus Controlled	8-52	DC Brake Select	14-4*	Energy Optimising
1-25	Motor Nominal Speed	3-11	Jog Speed [Hz]	5-90	Digital & Relay Bus Control	8-53	Start Select	14-40	VT Level
1-26	Motor Cont. Rated Torque	3-14	Preset Relative Reference	6-0*	Analog In/Out	8-54	Reversing Select	14-41	AEO Minimum Magnetisation
1-29	Automatic Motor Adaptation (AMA)	3-15	Reference 1 Source	6-00	Live Zero Timeout Time	8-55	Set-up Select	14-50	RFI Filter
1-3*	Adv. Motor Data	3-16	Reference 2 Source	6-01	Live Zero Timeout Function	8-56	Preset Reference Select	14-51	DC-Link Voltage Compensation
1-30	Stator Resistance (Rs)	3-17	Reference 3 Source	6-02	Fire Mode Live Zero Timeout Function	8-70	BACnet	14-52	Fan Control
1-33	Stator Leakage Reactance (Xl)	3-4*	Ramp 1	6-1*	Analog Input 53	8-72	BACnet Device Instance	14-53	Fan Monitor
1-35	Main Reactance (Xh)	3-41	Ramp 1 Ramp Up Time	6-10	Terminal 53 Low Voltage	8-73	M5/TP Max Masters	14-55	Output Filter
1-37	d-axis Inductance (Ld)	3-42	Ramp 1 Ramp Down Time	6-11	Terminal 53 High Voltage	8-74	"I am" Service	14-6*	Auto Derate
1-38	q-axis Inductance (Lq)	3-5*	Ramp 2	6-12	Terminal 53 Low Current	8-75	Initialisation Password	14-63	Min Switch Frequency
1-39	Motor Poles	3-51	Ramp 2 Ramp Up Time	6-13	Terminal 53 High Current	8-8*	FC Port Diagnostics	14-64	Dead Time Compensation Zero Current Level
1-4*	Adv. Motor Data II	3-52	Ramp 2 Ramp Down Time	6-14	Terminal 53 Low Ref./Feedb. Value	8-80	Bus Message Count	14-65	Speed Derate Dead Time Compensation
1-40	Back EMF at 1000 RPM	3-8*	Other Ramps	6-15	Terminal 53 High Ref./Feedb. Value	8-81	Bus Error Count		
1-42	Motor Cable Length	3-80	Jog Ramp Time	6-16	Terminal 53 Filter Time Constant	8-82	Slave Messages Rcvd		
1-43	Motor Cable Length Feet	3-81	Quick Stop Ramp Time	6-19	Terminal 53 mode	8-83	Slave Error Count		

14-9* Fault Settings	16-6* Inputs & Outputs	24-0* Fire Mode
14-90 Fault Level	16-60 Digital Input	24-00 FM Function
15** Drive Information	16-61 Terminal 53 Setting	24-01 Fire Mode Configuration
15-0* Operating Data	16-62 Analog Input AI53	24-05 FM Preset Reference
15-00 Operating hours	16-63 Terminal 54 Setting	24-06 Fire Mode Reference Source
15-01 Running Hours	16-64 Analog Input AI54	24-07 Fire Mode Feedback Source
15-02 kWh Counter	16-65 Analog Output AO42 [mA]	24-09 FM Alarm Handling
15-03 Power Up's	16-66 Digital Output	24-1* Drive Bypass
15-04 Over Temp's	16-67 Pulse Input #29 [Hz]	24-10 Drive Bypass Function
15-05 Over Volts	16-71 Relay Output [bin]	24-11 Drive Bypass Delay Time
15-06 Reset kWh Counter	16-72 Counter A	25** Cascade Controller
15-07 Reset Running Hours Counter	16-73 Counter B	25-00 Cascade Controller
15-3* Alarm Log	16-79 Analog Output AO45	25-04 Pump Cycling
15-30 Alarm Log: Error Code	16-8* Fieldbus & FC Port	25-05 Fixed Lead Pump
15-31 InternalFaultReason	16-86 FC Port REF 1	25-06 Number of Pumps
15-4* Drive Identification	16-9* Diagnosis Readouts	25-20 Staging Bandwidth
15-40 FC Type	16-90 Alarm Word	25-21 Override Bandwidth
15-41 Power Section	16-91 Alarm Word 2	25-22 Fixed Speed Bandwidth
15-42 Voltage	16-92 Warning Word	25-23 SBW Staging Delay
15-43 Software Version	16-93 Warning Word 2	25-24 SBW Destaging Delay
15-44 Ordered TypeCode	16-94 Ext. Status Word	25-25 OBW Time
15-45 Actual Typecode String	16-95 Ext. Status Word 2	25-27 Stage Function
15-46 Drive Ordering No	18** Info & Readouts	25-28 Stage Function Time
15-48 LCP Id No	18-1* Fire Mode Log	25-29 Destage Function
15-49 SW ID Control Card	18-10 FireMode Log:Event	25-30 Destage Function Time
15-50 SW ID Power Card	20** Drive Closed Loop	25-42 Staging Threshold
15-51 Drive Serial Number	20-0* Feedback	25-43 Destaging Threshold
15-53 Power Card Serial Number	20-00 Feedback 1 Source	25-45 Staging Speed [Hz]
15-59 CSIV Filename	20-01 Feedback 1 Conversion	25-47 Destaging Speed [Hz]
16** Data Readouts	20-03 (20-03) Feedback 2 Source	25-50 Lead Pump Alternation
16-0* General Status	20-04 Feedback 2 Conversion	25-51 Alternation Event
16-00 Control Word	20-2* Feedback/Setpoint	25-52 Alternation Time Interval
16-01 Reference [Unit]	20-20 Feedback Function	25-53 Alternation Timer Value
16-02 Reference [%]	20-48 Sleep Delay Time	25-55 Alternate if Load <= 50%
16-03 Status Word	20-49 Wake-Up Delay Time	25-56 Staging Mode at Alternation
16-05 Main Actual Value [%]	20-8* PI Basic Settings	25-57 Relays per Pump
16-09 Custom Readout	20-81 PI Normal/ Inverse Control	25-58 Run Next Pump Delay
16-1* Motor Status	20-83 PI Start Speed [Hz]	25-59 Run on Mains Delay
16-10 Power [kW]	20-84 On Reference Bandwidth	25-80 Cascade Status
16-11 Power [hp]	20-9* PI Controller	25-81 Pump Status
16-12 Motor Voltage	20-91 PI Anti Windup	25-84 Pump ON Time
16-13 Frequency	20-93 PI Proportional Gain	25-90 Pump Interlock
16-14 Motor current	20-94 PI Integral Time	30** Special Features
16-15 Frequency [%]	20-97 PI Feed Forward Factor	30-2* Adv. Start Adjust
16-16 Torque [Nm]	22** Appl. Functions	30-22 Locked Rotor Detection
16-18 Motor Thermal	22-02 Sleepmode CL Control Mode	30-23 Locked Rotor Detection Time [s]
16-22 Torque [%]	22-4* Sleep Mode	
16-3* Drive Status	22-40 Minimum Run Time	
16-30 DC Link Voltage	22-41 Minimum Sleep Time	
16-34 Heatsink Temp.	22-43 Wake-Up Speed [Hz]	
16-35 Inverter Thermal	22-44 Wake-Up Ref/FB Diff	
16-36 Inv. Nom. Current	22-45 Setpoint Boost	
16-37 Inv. Max. Current	22-46 Maximum Boost Time	
16-38 SL Controller State	22-47 Sleep Speed [Hz]	
16-5* Ref. & Feeds	22-6* Broken Belt Detection	
16-50 External Reference	22-60 Broken Belt Function	
16-52 Feedback[Unit]	22-61 Broken Belt Torque	
16-54 Feedback 1 [Unit]	22-62 Broken Belt Delay	
16-55 Feedback 2 [Unit]	24** Appl. Functions 2	

5 Cascade Controller

5.1 Introduction

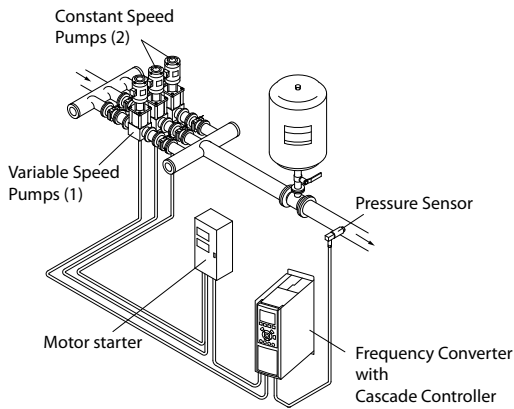

130BA362.10

Illustration 5.1 Cascade Controller

The cascade controller is used for pump applications where a certain pressure (head) or level needs to be maintained over a wide dynamic range. Running a large pump at variable speed over a wide for range is not an ideal solution because of low pump efficiency and because there is a practical limit of about 25% rated full load speed for running a pump.

In the cascade controller, the frequency converter controls a variable speed motor as the variable speed pump (lead) and can stage up to 2 additional constant speed pumps on and off. By varying the speed of the initial pump, variable speed control of the entire system is provided, which maintains constant pressure while eliminating pressure surges, resulting in reduced system stress and quieter operation in pumping systems.

Fixed lead pump

The motors must be of equal size. The cascade controller allows the frequency converter to control up to 5 equal size pumps using the 2 built-in relays of the frequency converter and terminals 27, 29 (digital input/digital output). When the variable pump (lead) is connected directly to the frequency converter, the other 4 pumps are controlled by the 2 built-in relays and terminals 27, 29 (digital input/digital output). Lead pump alternation cannot be selected when lead pump is fixed.

Lead pump alternation

The motors must be of equal size. This function makes it possible to cycle the frequency converter between the pumps in the system (when *parameter 25-57 Relays per Pump* = 1, the maximum pump is 4. When *parameter 25-57 Relays per Pump* = 2, the maximum pump is 3). In this operation, the run time between pumps is equalised reducing the required pump maintenance and

increasing reliability and lifetime of the system. The alternation of the lead pump can take place at a command signal or at staging (adding lag pump).

The command can be a manual alternation or an alternation event signal. If the alternation event is selected, the lead pump alternation takes place every time the event occurs. Selections include whenever an alternation timer expires, when the lead pump goes into sleep mode. Staging is determined by the actual system load.

When *parameter 25-55 Alternate if Load <= 50%* = 1, if load >50%, alternation does not happen. If load <50%, alternation happens. When *parameter 25-55 Alternate if Load <= 50%* = 0, alternation happens regardless of the load. The total pump capacity is determined as lead pump plus lag speed pumps capacities.

Bandwidth management

In cascade control systems, to avoid frequent switching of fixed speed pumps, the desired system pressure is kept within a bandwidth rather than at a constant level. The staging bandwidth provides the required bandwidth for operation. When a large and quick change in system pressure occurs, the override bandwidth overrides the staging bandwidth to prevent immediate response to a short duration pressure change. An override bandwidth timer can be programmed to prevent staging until the system pressure has stabilised and normal control established.

When the cascade controller is enabled and running normally, and the frequency converter issues a trip alarm, the system head is maintained by staging and destaging fixed speed pumps. To prevent frequent staging and destaging, and to minimise pressure fluctuations, use a wider fixed speed bandwidth instead of the staging bandwidth.

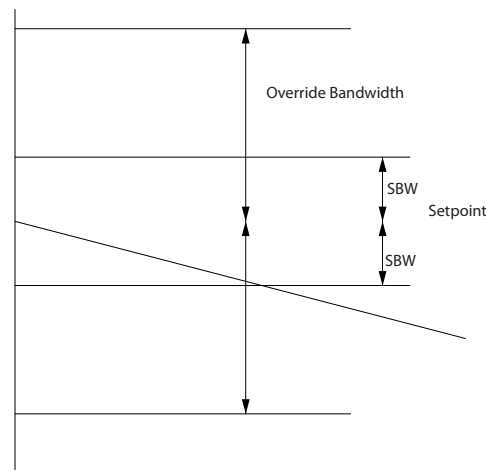

175ZA673.10

Illustration 5.2 Bandwidth

5.2 System Status and Operation

Only when lead pump is working, the frequency converter can go into sleep mode. When the cascade controller is enabled, the operation status for each pump and the cascade controller is displayed in *parameter 25-81 Pump Status* and *parameter 25-80 Cascade Status* on the LCP. The cascade controller information displayed includes:

- Pumps status, is a readout of the status for the relays assigned to each pump. The display shows pumps that are disabled, off, running on the frequency converter, or running on the mains/motor starter.
- Cascade status, is a readout of the status for the cascade controller. The display shows that if cascade controller is disabled, all pumps are running off, fixed speed pumps are being staged/de-staged, and lead pump alternation is occurring.

5.3 Start/Stop Conditions

See 5-1* *Digital Inputs*.

Digital input commands	Variable speed pump (lead)	Fixed speed pumps (lag)
Start (SYSTEM START/STOP)	Ramps up (if stopped and there is a demand)	Staging (if stopped and there is a demand)
Lead oup start	Ramps up if SYSTEM START is active	Not affected
Coast (EMERGENCY STOP)	Coast to stop	Cut out (correspond relays, terminal 27/29 and 42/45)
External interlock	Coast to stop	Cut out (built-in relays are de-energised)

Table 5.1 Commands Assigned to Digital Inputs

LCP keys	Variable speed pump (lead)	Fixed speed pumps (lag)
[Hand On]	Ramps up (if stopped by a normal stop command) or stays in operation if already running	Destaging (if running)
[Off]	Ramps down	Destaging
[Auto On]	Starts and stops according to commands via terminals or serial bus. Cascade controller only works when the frequency converter is in <i>Auto On</i> mode.	Staging/Destaging

Table 5.2 LCP Key Functions

5.4 Cascade Controller Wizard

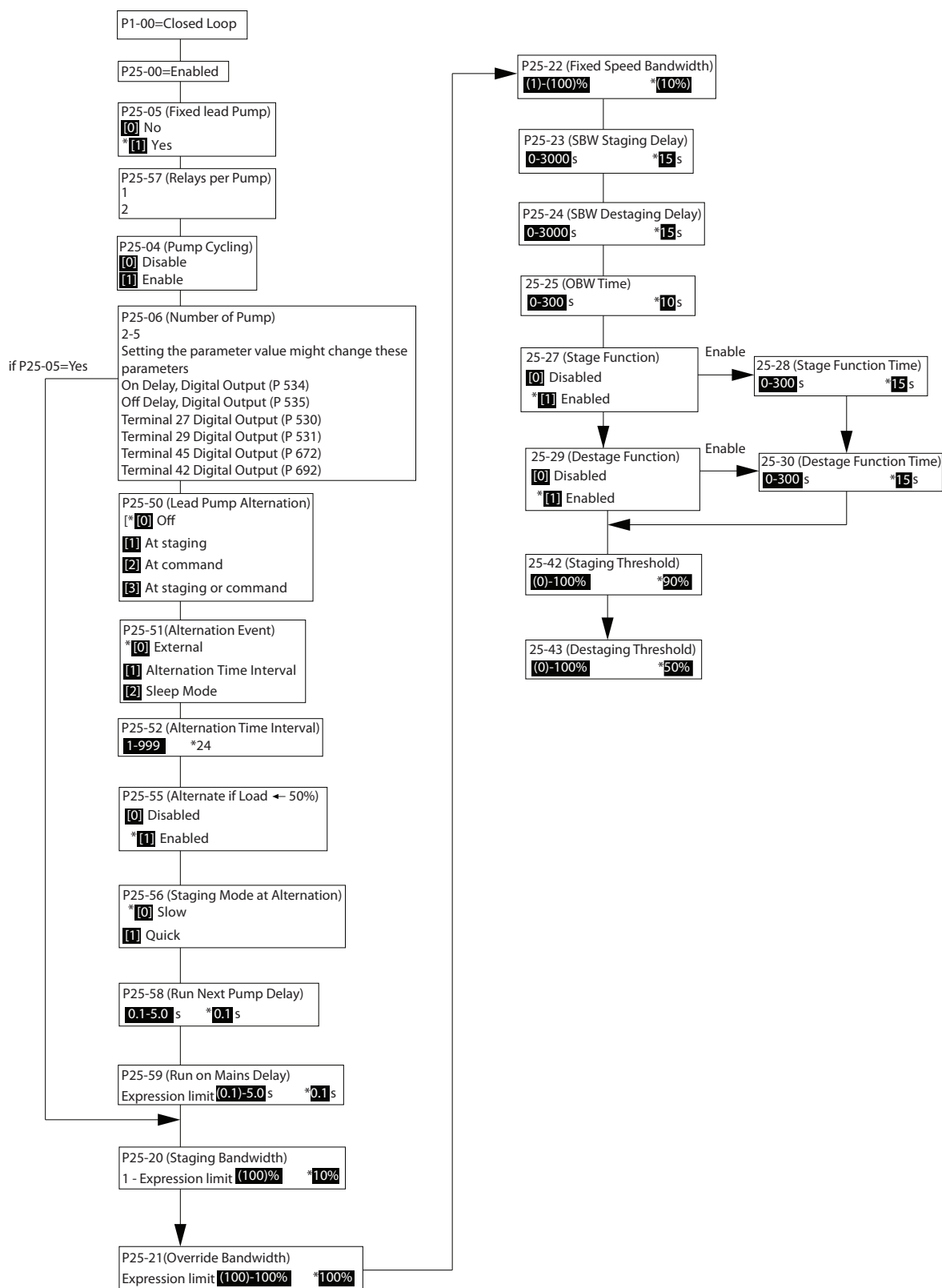

130BD161.10

Illustration 5.3 Cascade Controller Wizard (Recommended Logistic)

5.5 Cascade Controller Connection

1 pump, 1 relay mode: When parameter 25-57 Relays per Pump=1

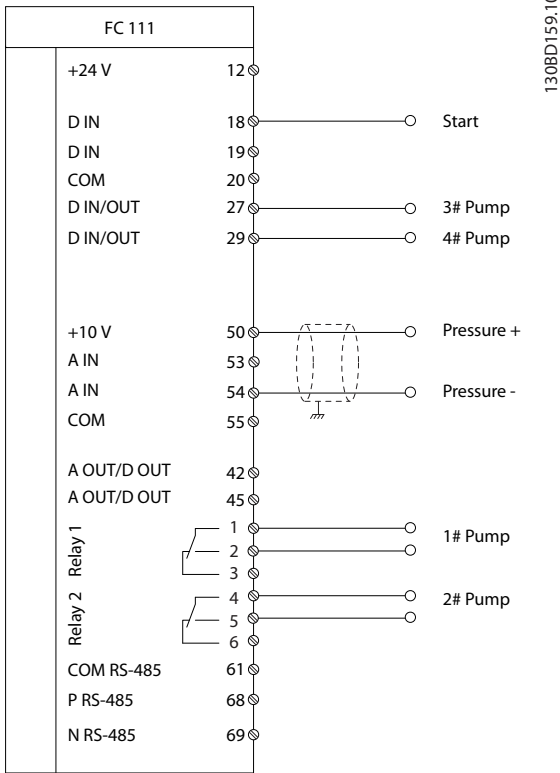

1308BD159.10

Illustration 5.4 1 Pump, 1 Relay Mode

Every pump operation is controlled by 1 output.

1. When parameter 25-04 Pump Cycling=[0] Disable: Maximum 5 pumps.
2. When parameter 25-04 Pump Cycling=[1] Enable: Maximum 4 pumps.
3. 2 relays and 2 digital outputs are available.

1 pump, 2 relay mode: When parameter 25-57 Relays per Pump=2

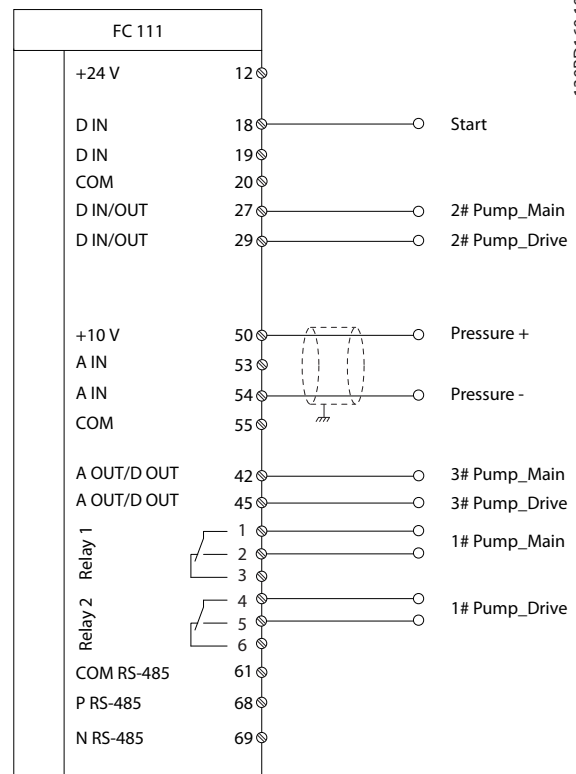

1308BD160.10

Illustration 5.5 1 Pump, 2 Relay Mode

Every pump operation is controlled by 2 outputs.

1. Dedicated PLC not necessary as control
2. When parameter 25-04 Pump Cycling = [0] Disable: no pump.
3. When parameter 25-04 Pump Cycling = [1] Enable: Maximum 3 pumps.
4. 2 relays, 2 digital outputs and 2 analog outputs are available.

6 Warnings and Alarms

6.1 List of Warnings and Alarms

Fault number	Alarm/warning bit number	Fault text	Warning	Alarm	Trip locked	Cause of problem
2	16	Live zero error	X	X	-	Signal on terminal 53 or 54 is less than 50% of the value set in <i>parameter 6-10 Terminal 53 Low Voltage</i> , <i>parameter 6-12 Terminal 53 Low Current</i> , <i>parameter 6-20 Terminal 54 Low Voltage</i> , or <i>parameter 6-22 Terminal 54 Low Current</i> . See also parameter group 6-0* <i>Analog I/O Mode</i> .
4	14	Mains ph. loss	X	X	X	Missing phase on the supply side or too high voltage imbalance. Check the supply voltage. See <i>parameter 14-12 Function at Mains Imbalance</i> .
7	11	DC over volt	X	X	-	DC-link voltage exceeds the limit.
8	10	DC under volt	X	X	-	DC-link voltage drops below <i>voltage warning low</i> limit.
9	9	Inverter overload	X	X	-	More than 100% load for a long time.
10	8	Motor ETR over	X	X	-	The motor is too hot due to more than 100% load for a long time. See <i>parameter 1-90 Motor Thermal Protection</i> .
11	7	Motor th over	X	X	-	The thermistor or thermistor connection is disconnected. See <i>parameter 1-90 Motor Thermal Protection</i> .
13	5	Over Current	X	X	X	Inverter peak current limit is exceeded.
14	2	Earth Fault	-	X	X	Discharge from output phases to ground.
16	12	Short Circuit	-	X	X	Short-circuit in motor or on motor terminals.
17	4	Ctrl. word TO	X	X	-	No communication to frequency converter. See parameter group 8-0* <i>General Settings</i> .
24	50	Fan Fault	X	X	-	The heat sink cooling fan is not working (only on 400 V, 30–90 kW units).
30	19	U phase loss	-	X	X	Motor phase U is missing. Check the phase. See <i>parameter 4-58 Missing Motor Phase Function</i> .
31	20	V phase loss	-	X	X	Motor phase V is missing. Check the phase. See <i>parameter 4-58 Missing Motor Phase Function</i> .
32	21	W phase loss	-	X	X	Motor phase W is missing. Check the phase. See <i>parameter 4-58 Missing Motor Phase Function</i> .
38	17	Internal fault	-	X	X	Contact the local Danfoss supplier.
44	28	Earth Fault	-	X	X	Discharge from output phases to ground, using the value of <i>parameter 15-31 Alarm Log Value</i> if possible.
46	33	Control Voltage Fault	-	X	X	Control voltage is low. Contact the local Danfoss supplier.
47	23	24 V supply low	X	X	X	24 V DC supply may be overloaded.
50		AMA calibration failed	-	X	-	Contact the local Danfoss supplier.
51	15	AMA U _{nom} , I _{nom}	-	X	-	The setting of motor voltage, motor current, and motor power is wrong. Check the settings.
52	-	AMA low Inom	-	X	-	The motor current is too low. Check the settings.
53	-	AMA big motor	-	X	-	The motor is too large to perform AMA.
54	-	AMA small mot	-	X	-	The motor is too small to perform AMA.
55	-	AMA par. range	-	X	-	The parameter values found from the motor are outside the acceptable range.
56	-	AMA user interrupt	-	X	-	The AMA is manually interrupted.

Fault number	Alarm/warning bit number	Fault text	Warning	Alarm	Trip locked	Cause of problem
57	-	AMA timeout	-	X	-	Try to restart the AMA a number of times, until the AMA is carried out. NOTICE Repeated runs may heat the motor to a level where the resistance R_s and R_r are increased. In most cases, this situation is not critical.
58	-	AMA internal	X	X	-	Contact the local Danfoss supplier.
59	25	Current limit	X	-	-	The current is higher than the value in <i>parameter 4-18 Current Limit</i> .
60	44	External Interlock	-	X	-	External interlock has been activated. To resume normal operation, apply 24 V DC to the terminal programmed for external interlock and reset the frequency converter (via serial communication, digital I/O, or by pressing reset key on keypad).
66	26	Heat sink Temperature Low	X	-	-	This warning is based on the temperature sensor in the IGBT module (on 400 V, 30-90 kW units).
69	1	Pwr. Card Temp	X	X	X	The temperature sensor on the power card exceeds the upper or lower limits.
70	36	Illegal FC configuration	-	X	X	The control card and power card are not matched.
79	-	Illegal power section configuration	X	X	-	Internal fault. Contact the local Danfoss supplier.
80	29	Drive initialised	-	X	-	All parameter settings are initialised to default settings.
87	47	Auto DC Braking	X	-	-	The frequency converter is auto DC braking.
95	40	Broken Belt	X	X	-	Torque is below the torque level set for no load, indicating a broken belt. See parameter group 22-6* <i>Broken Belt Detection</i> .
126	-	Motor Rotating	-	X	-	High back EMF voltage. Stop the rotor of the PM motor.
200	-	Fire Mode	X	-	-	Fire mode has been activated.
202	-	Fire Mode Limits Exceeded	X	-	-	Fire mode has suppressed 1 or more warranty voiding alarms.
250	-	New spare part	-	X	X	The power or switch mode power supply has been exchanged (on 400 V, 30-90 kW units). Contact the local Danfoss supplier.
251	-	New type code	-	X	X	The frequency converter has a new type code (on 400 V, 30-90 kW units). Contact the local Danfoss supplier.

Table 6.1 Warnings and Alarms

6.2 List of LCP Errors

LCP errors are not warnings or alarms. They do not affect the operation of the frequency converter. *Illustration 6.1* shows an LCP error on the LCP.

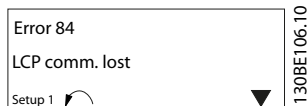

Illustration 6.1 LCP Error Example

LCP error code	Error message	Description
Err 84	LCP comm. Lost	Communication between the LCP and the frequency converter is lost.
Err 85	Button disabled	The LCP key is disabled. One of the LCP keys has been disabled in parameter group 0-4* LCP Keypad.
Err 86	LCP copy failed	Data copy failure. This error occurs when data is copied from frequency converter to LCP, or from LCP to frequency converter (<i>parameter 0-50 LCP Copy</i>).
Err 88	Data not compatible	LCP data incompatible. This error occurs when data is being copied from LCP to frequency converter (<i>parameter 0-50 LCP Copy</i>). The typical reason is that data is moved between frequency converter and LCP that have major software differences.
Err 89	Read only	Parameter read only. An operation is issued via LCP to write a value to a parameter that is read-only.
Err 90	Database busy	The parameter database of the frequency converter is busy.
Err 91	Parameter invalid	The parameter value that is input via the LCP is invalid.
Err 92	Exceeds limits	The parameter value that is input via the LCP exceeds limits.
Err 93	Motor is running	The LCP copy operation cannot be performed when the frequency converter is running.
Err 95	Not while running	The parameter cannot be changed while the frequency converter is running.
Err 96	Password rejected	The password that is input via the LCP is incorrect.

Table 6.2 LCP Error List

7 Specifications

7.1 Mains Supply 3x380–480 V

Frequency converter	PK37	PK75	P1K5	P2K2	P3K0	P4K0	P5K5	P7K5	P11K	P15K
Typical shaft output [kW]	0.37	0.75	1.5	2.2	3.0	4.0	5.5	7.5	11.0	15.0
Typical shaft output [hp]	0.5	1.0	2.0	3.0	4.0	5.0	7.5	10.0	15.0	20.0
Protection rating IP20	H1	H1	H1	H2	H2	H2	H3	H3	H4	H4
Maximum cable size in terminals (mains, motor) [mm ² (AWG)]	4 (10)	4 (10)	4 (10)	4 (10)	4 (10)	4 (10)	4 (10)	4 (10)	16 (6)	16 (6)
Output current - 40 °C (104 °F) ambient temperature										
Continuous (3x380–440 V) [A]	1.2	2.2	3.7	5.3	7.2	9.0	12.0	15.5	23.0	31.0
Intermittent (3x380–440 V) [A]	1.3	2.4	4.1	5.8	7.9	9.9	13.2	17.1	25.3	34.0
Continuous (3x441–480 V) [A]	1.1	2.1	3.4	4.8	6.3	8.2	11.0	14.0	21.0	27.0
Intermittent (3x441–480 V) [A]	1.2	2.3	3.7	5.3	6.9	9.0	12.1	15.4	23.1	29.7
Maximum input current										
Continuous (3x380–440 V) [A]	1.2	2.1	3.5	4.7	6.3	8.3	11.2	15.1	22.1	29.9
Intermittent (3x380–440 V) [A]	1.3	2.3	3.9	5.2	6.9	9.1	12.3	16.6	24.3	32.9
Continuous (3x441–480 V) [A]	1.0	1.8	2.9	3.9	5.3	6.8	9.4	12.6	18.4	24.7
Intermittent (3x441–480 V) [A]	1.1	2.0	3.2	4.3	5.8	7.5	10.3	13.9	20.2	27.2
Maximum mains fuses	See chapter 3.2.4 Fuses and Circuit Breakers.									
Estimated power loss [W], best case/typical ¹⁾	13/15	16/21	46/57	46/58	66/83	95/118	104/131	159/198	248/274	353/379
Weight enclosure protection rating IP20 [kg (lb)]	2.0 (4.4)	2.0 (4.4)	2.1 (4.6)	3.3 (7.3)	3.3 (7.3)	3.4 (7.5)	4.3 (9.5)	4.5 (9.9)	7.9 (17.4)	7.9 (17.4)
Efficiency [%], best case/typical ²⁾	97.8/97.3	98.0/97.6	97.7/97.2	98.3/97.9	98.2/97.8	98.0/97.6	98.4/98.0	98.2/97.8	98.1/97.9	98.0/97.8
Output current - 50 °C (122 °F) ambient temperature										
Continuous (3x380–440 V) [A]	1.04	1.93	3.7	4.85	6.3	8.4	10.9	14.0	20.9	28.0
Intermittent (3x380–440 V) [A]	1.1	2.1	4.07	5.4	6.9	9.2	12.0	15.4	23.0	30.8
Continuous (3x441–480 V) [A]	1.0	1.8	3.4	4.4	5.5	7.5	10.0	12.6	19.1	24.0
Intermittent (3x441–480 V) [A]	1.1	2.0	3.7	4.8	6.1	8.3	11.0	13.9	21.0	26.4

Table 7.1 3x380–480 V AC, 0.37–15 kW (0.5–20 hp), Enclosure Sizes H1–H4

1) Applies for dimensioning of frequency converter cooling. If the switching frequency is higher than the default setting, the power losses may increase. LCP and typical control card power consumptions are included. For power loss data according to EN 50598-2, refer to www.danfoss.com/vltenerefficiency.

2) Efficiency measured at nominal current. For energy efficiency class, see chapter 7.4.1 Ambient Conditions. For part load losses, see www.danfoss.com/vltenerefficiency.

Frequency converter	P18K	P22K	P30K	P37K	P45K	P55K	P75K	P90K
Typical shaft output [kW]	18.5	22.0	30.0	37.0	45.0	55.0	75.0	90.0
Typical shaft output [hp]	25.0	30.0	40.0	50.0	60.0	70.0	100.0	125.0
Protection rating IP20	H5	H5	H6	H6	H6	H7	H7	H8
Maximum cable size in terminals (mains, motor) [mm ² (AWG)]	16 (6)	16 (6)	35 (2)	35 (2)	35 (2)	50 (1)	95 (0)	120 (250MCM)
Output current - 40 °C (104 °F) ambient temperature								
Continuous (3x380–440 V)[A]	37.0	42.5	61.0	73.0	90.0	106.0	147.0	177.0
Intermittent (3x380–440 V) [A]	40.7	46.8	67.1	80.3	99.0	116.0	161.0	194.0
Continuous (3x441–480 V) [A]	34.0	40.0	52.0	65.0	80.0	105.0	130.0	160.0
Intermittent (3x441–480 V) [A]	37.4	44.0	57.2	71.5	88.0	115.0	143.0	176.0
Maximum input current								
Continuous (3x380–440 V) [A]	35.2	41.5	57.0	70.0	84.0	103.0	140.0	166.0
Intermittent (3x380–440 V) [A]	38.7	45.7	62.7	77.0	92.4	113.0	154.0	182.0
Continuous (3x441–480 V) [A]	29.3	34.6	49.2	60.6	72.5	88.6	120.9	142.7
Intermittent (3x441–480 V) [A]	32.2	38.1	54.1	66.7	79.8	97.5	132.9	157.0
Maximum mains fuses	See chapter 3.2.4 Fuses and Circuit Breakers.							
Estimated power loss [W], best case/typical ¹⁾	412/456	475/523	733	922	1067	1133	1733	2141
Weight enclosure protection rating IP20 [kg (lb)]	9.5 (20.9)	9.5 (20.9)	24.5 (54)	24.5 (54)	24.5 (54)	36.0 (79.4)	36.0 (79.4)	51.0 (112.4)
Efficiency [%], best case/typical ²⁾	98.1/97.9	98.1/97.9	97.8	97.7	98	98.2	97.8	97.9
Output current - 50 °C (122 °F) ambient temperature								
Continuous (3x380–440 V) [A]	34.1	38.0	48.8	58.4	72.0	74.2	102.9	123.9
Intermittent (3x380–440 V) [A]	37.5	41.8	53.7	64.2	79.2	81.6	113.2	136.3
Continuous (3x441–480 V) [A]	31.3	35.0	41.6	52.0	64.0	73.5	91.0	112.0
Intermittent (3x441–480 V) [A]	34.4	38.5	45.8	57.2	70.4	80.9	100.1	123.2

Table 7.2 3x380–480 V AC, 18.5–90 kW (25–125 hp), Enclosure Sizes H5–H8

1) Applies for dimensioning of frequency converter cooling. If the switching frequency is higher than the default setting, the power losses may increase. LCP and typical control card power consumptions are included. For power loss data according to EN 50598-2, refer to www.danfoss.com/vlteneregyefficiency.

2) Efficiency measured at nominal current. For energy efficiency class, see chapter 7.4.1 Ambient Conditions. For part load losses, see www.danfoss.com/vlteneregyefficiency.

7.2 EMC Emission Test Results

The test results in *Table 7.3* were obtained using a system with a frequency converter, a screened control cable, a control box with potentiometer, and a screened motor cable.

RFI filter type	Conduct emission. Maximum screened cable length [m]						Radiated emission			
	Industrial environment		Class B		Class A Group 1		Class A Group 1		Class B	
EN 55011	Class A Group 2 Industrial environment	Class A Group 1 Industrial environment	Class B Housing, trades and light industries		Class A Group 1 Industrial environment		Class A Group 1 Industrial environment		Class B Housing, trades and light industries	
EN/IEC 61800-3	Category C3 Second environment Industrial	Category C2 First environment Home and office	Category C1 First environment Home and office		Category C2 First environment Home and office		Category C2 First environment Home and office		Category C1 First environment Home and office	
	Without external filter	With external filter	Without external filter	With external filter	Without external filter	With external filter	Without external filter	With external filter	Without external filter	With external filter
H4 RFI filter (EN55011 A1, EN/IEC61800-3 C2)										
0.37–22 kW 3x380–480 V IP20	–	–	25	50	–	20	Yes	Yes	–	No
H2 RFI filter (EN 55011 A2, EN/IEC 61800-3 C3)										
30–90 kW 3x380–480 V IP20	25	–	–	–	–	–	No	–	No	–
H3 RFI filter (EN55011 A1/B, EN/IEC 61800-3 C2/C1)										
30–90 kW 3x380–480 V IP20	–	–	50	–	20	–	Yes	–	No	–

Table 7.3 EMC Emission Test Results

7.3 Special Conditions

NOTICE

Do not use IP20/IP21 FC 111 units in dusty or humid environments. See *chapter 7.4 General Technical Data* for details.

7.3.1 Derating for Ambient Temperature and Switching Frequency

Ensure that the ambient temperature measured over 24 hours is at least 5 °C lower than the maximum ambient temperature that is specified for the frequency converter. If the frequency converter is operated at a high ambient temperature, decrease the continuous output current. For derating curve, see *VLT® HVAC Basic Drive FC 101 Design Guide*.

7.3.2 Derating for Low Air Pressure and High Altitudes

The cooling capability of air is decreased at low air pressure. For altitudes above 2000 m (6562 ft), contact Danfoss regarding PELV. Below 1000 m (3281 ft) altitude, no derating is necessary. For altitudes above 1000 m (3281 ft), decrease the ambient temperature or the maximum output current. Decrease the output by 1% per 100 m (328 ft) altitude above 1000 m (3281 ft) or reduce the maximum ambient temperature by 1 °C per 200 m (656 ft).

7.4 General Technical Data

Protection and features

- Electronic motor thermal protection against overload.
- Temperature monitoring of the heat sink ensures that the frequency converter trips in case of overtemperature.
- The frequency converter is protected against short circuits between motor terminals U, V, W.
- When a motor phase is missing, the frequency converter trips and issues an alarm.
- When a mains phase is missing, the frequency converter trips or issues a warning (depending on the load).
- Monitoring of the DC-link voltage ensures that the frequency converter trips when the DC-link voltage is too low or too high.
- The frequency converter is protected against ground faults on motor terminals U, V, W.

Mains supply (L1, L2, L3)

Supply voltage	380–480 V ±10%
Supply frequency	50/60 Hz
Maximum imbalance temporary between mains phases	3.0% of rated supply voltage
True power factor (λ)	≥0.9 nominal at rated load
Displacement power factor ($\cos\phi$) near unity	(>0.98)
Switching on the input supply L1, L2, L3 (power-ups) enclosure sizes H1–H5	Maximum 2 times/min.
Switching on the input supply L1, L2, L3 (power-ups) enclosure sizes H6–H8	Maximum 1 time/min.
Environment according to EN 60664-1	Overvoltage category III/pollution degree 2
The unit is suitable for use on a circuit capable of delivering not more than 100000 A _{rms} symmetrical Amperes, 240/480 V maximum.	

Motor output (U, V, W)

Output voltage	0–100% of supply voltage
Output frequency	0–200 Hz (VVC ⁺), 0–400 Hz (u/f)
Switching on output	Unlimited
Ramp times	0.05–3600 s

Cable length and cross-section

Maximum motor cable length, screened/armoured (EMC-correct installation)	See <i>chapter 7.2 EMC Emission Test Results</i>
Maximum motor cable length, unscreened/unarmoured	50 m
Maximum cross-section to motor, mains ¹⁾	
Cross-section DC terminals for filter feedback on enclosure sizes H1–H3, I2, I3, I4	4 mm ² /11 AWG
Cross-section DC terminals for filter feedback on enclosure sizes H4–H5	16 mm ² /6 AWG
Maximum cross-section to control terminals, rigid wire	2.5 mm ² /14 AWG
Maximum cross-section to control terminals, flexible cable	2.5 mm ² /14 AWG
Minimum cross-section to control terminals	0.05 mm ² /30 AWG

1) See *chapter 7.1 Mains Supply 3x380–480 V* for more information

Digital inputs

Programmable digital inputs	4
Terminal number	18, 19, 27, 29
Logic	PNP or NPN
Voltage level	0–24 V DC
Voltage level, logic 0 PNP	<5 V DC
Voltage level, logic 1 PNP	>10 V DC
Voltage level, logic 0 NPN	>19 V DC
Voltage level, logic 1 NPN	<14 V DC
Maximum voltage on input	28 V DC
Input resistance, R _i	Approximately 4 kΩ
Digital input 29 as thermistor input	Fault: >2.9 kΩ and no fault: <800 Ω
Digital input 29 as pulse input	Maximum frequency 32 kHz push-pull-driven & 5 kHz (O.C.)

Analog inputs

Number of analog inputs	2
Terminal number	53, 54
Terminal 53 mode	Parameter 6-19 Terminal 53 mode: 1=voltage, 0=current
Terminal 54 mode	Parameter 6-29 Terminal 54 mode: 1=voltage, 0=current
Voltage level	0–10 V
Input resistance, R_i	Approximately 10 k Ω
Maximum voltage	20 V
Current level	0/4 to 20 mA (scalable)
Input resistance, R_i	<500 Ω
Maximum current	29 mA
Resolution on analog input	10 bit

Analog output

Number of programmable analog outputs	2
Terminal number	42, 45 ¹⁾
Current range at analog output	0/4–20 mA
Maximum load to common at analog output	500 Ω
Maximum voltage at analog output	17 V
Accuracy on analog output	Maximum error: 0.4% of full scale
Resolution on analog output	10 bit

1) Terminal 42 and 45 can also be programmed as digital outputs.

Digital output

Number of digital outputs	4
Terminals 27 and 29	
Terminal number	27, 29 ¹⁾
Voltage level at digital output	0–24 V
Maximum output current (sink and source)	40 mA
Terminals 42 and 45	
Terminal number	42, 45 ²⁾
Voltage level at digital output	17 V
Maximum output current at digital output	20 mA
Maximum load at digital output	1 k Ω

1) Terminals 27 and 29 can also be programmed as input.

2) Terminals 42 and 45 can also be programmed as analog output.

The digital outputs are galvanically isolated from the supply voltage (PELV) and other high-voltage terminals.

Control card, RS485 serial communication

Terminal number	68 (P, TX+, RX+), 69 (N, TX-, RX-)
Terminal number	61 common for terminals 68 and 69

Control card, 24 V DC output

Terminal number	12
Maximum load	80 mA

Relay output

Programmable relay output	2
Relay 01 and 02	01-03 (NC), 01-02 (NO), 04-06 (NC), 04-05 (NO)
Maximum terminal load (AC-1) ¹⁾ on 01-02/04-05 (NO) (Resistive load)	250 V AC, 3 A
Maximum terminal load (AC-15) ¹⁾ on 01-02/04-05 (NO) (Inductive load @ cosφ 0.4)	250 V AC, 0.2 A
Maximum terminal load (DC-1) ¹⁾ on 01-02/04-05 (NO) (Resistive load)	30 V DC, 2 A
Maximum terminal load (DC-13) ¹⁾ on 01-02/04-05 (NO) (Inductive load)	24 V DC, 0.1 A
Maximum terminal load (AC-1) ¹⁾ on 01-03/04-06 (NC) (Resistive load)	250 V AC, 3 A
Maximum terminal load (AC-15) ¹⁾ on 01-03/04-06 (NC) (Inductive load @ cosφ 0.4)	250 V AC, 0.2 A
Maximum terminal load (DC-1) ¹⁾ on 01-03/04-06 (NC) (Resistive load)	30 V DC, 2 A
Minimum terminal load on 01-03 (NC), 01-02 (NO)	24 V DC 10 mA, 24 V AC 20 mA
Environment according to EN 60664-1	Overtoltage category III/pollution degree 2

1) IEC 60947 parts 4 and 5.

Control card, 10 V DC output

Terminal number	50
Output voltage	10.5 V ±0.5 V
Maximum load	25 mA

Ambient conditions

Enclosure protection rating	IP20, IP54
Enclosure kit available	IP21, TYPE 1
Vibration test	1.0 g
Maximum relative humidity	5%-95% (IEC 60721-3-3; Class 3K3 (non-condensing) during operation
Aggressive environment (IEC 60721-3-3), coated (standard) enclosure sizes H1-H5	Class 3C3
Aggressive environment (IEC 60721-3-3), non-coated enclosure sizes H6-H10	Class 3C2
Aggressive environment (IEC 60721-3-3), coated (optional) enclosure sizes H6-H10	Class 3C3
Aggressive environment (IEC 60721-3-3), non-coated enclosure sizes I2-I8	Class 3C2
Test method according to IEC 60068-2-43 H2S (10 days)	
Ambient temperature ¹⁾	See maximum output current at 40/50 °C in <i>chapter 7.1 Mains Supply 3x380-480 V</i> .

Minimum ambient temperature during full-scale operation	0 °C
Minimum ambient temperature at reduced performance	-20 °C
Minimum ambient temperature at reduced performance	-10 °C
Temperature during storage/transport	-30 to +65/70 °C
Maximum altitude above sea level without derating	1000 m
Maximum altitude above sea level with derating	3000 m
Derating for high altitude, see <i>chapter 7.3.2 Derating for Low Air Pressure and High Altitudes</i> .	
Safety standards	EN/IEC 61800-5-1, UL 508C
EMC standards, Emission	EN 61800-3, EN 61000-6-3/4, EN 55011, IEC 61800-3 EN 61800-3, EN 61000-3-12, EN 61000-6-1/2, EN 61000-4-2, EN 61000-4-3, EN 61000-4-4,
EMC standards, Immunity	EN 61000-4-5, EN 61000-4-6
Energy efficiency class	IE2

1) Refer to *Special Conditions in the design guide* for:

- Derating for high ambient temperature.
- Derating for high altitude.

2) Determined according to EN 50598-2 at:

- Rated load.
- 90% rated frequency.
- Switching frequency factory setting.
- Switching pattern factory setting.



.....
Danfoss can accept no responsibility for possible errors in catalogues, brochures and other printed material. Danfoss reserves the right to alter its products without notice. This also applies to products already on order provided that such alterations can be made without subsequential changes being necessary in specifications already agreed. All trademarks in this material are property of the respective companies. Danfoss and the Danfoss logotype are trademarks of Danfoss A/S. All rights reserved.
.....

Danfoss A/S
Ulsnaes 1
DK-6300 Graasten
vlt-drives.danfoss.com

