



# Quick Guide

## TR150 and TR170

### SAFETY WARNING

Only qualified personnel should install and service the equipment. The installation, starting up, and servicing of heating, ventilating, and air-conditioning equipment can be hazardous and requires specific knowledge and training. Improperly installed, adjusted or altered equipment by an unqualified person could result in death or serious injury. When working on the equipment, observe all precautions in the literature and on the tags, stickers, and labels that are attached to the equipment.

**Contents**

<b>1 Introduction</b>	<b>3</b>
1.1 Purpose of the Quick Guide	3
1.2 Additional Resources	3
1.3 Document and Software Version	3
1.4 Certificates and Approvals	3
1.5 Disposal	3
<b>2 Safety</b>	<b>4</b>
2.1 Safety Symbols	4
2.2 Qualified Personnel	4
2.3 Safety	4
2.4 Motor Thermal Protection	5
<b>3 Installation</b>	<b>6</b>
3.1 Mechanical Installation	6
3.1.1 Side-by-side Installation	6
3.1.2 Frequency Converter Dimensions	7
3.2 Electrical Installation	8
3.2.1 IT Mains	9
3.2.2 Connecting to Mains and Motor	9
3.2.3 Fuses and Circuit Breakers	13
3.2.4 EMC-correct Electrical Installation	14
3.2.5 Control Terminals	16
3.2.6 Acoustic Noise or Vibration	17
<b>4 Programming</b>	<b>18</b>
4.1 Keypad	18
4.2 Set-up Wizard	19
4.3 Parameter List	33
<b>5 Warnings and Alarms</b>	<b>36</b>
<b>6 Specifications</b>	<b>38</b>
6.1 Mains Supply	38
6.1.1 3x200–240 V AC	38
6.1.2 3x380–480 V AC	40
6.1.3 3x525–600 V AC	42
6.2 EMC Emission Test Results	43
6.2.1 EMC Emission Test Results	43
6.3 Special Conditions	44
6.3.1 Derating for Ambient Temperature and Switching Frequency	44

6.3.2 Derating for Low Air Pressure and High Altitudes	44
6.4 General Technical Data	44
6.4.1 Mains Supply (L1, L2, L3)	44
6.4.2 Motor Output (U, V, W)	44
6.4.3 Cable Length and Cross-section	44
6.4.4 Digital Inputs	45
6.4.5 Analog Inputs	45
6.4.6 Analog Output	45
6.4.7 Control Card, RS485 Serial Communication	46
6.4.8 Control Card, 24 V DC Output	46
6.4.9 Relay Output	46
6.4.10 Ambient Conditions	47
<b>Index</b>	<b>48</b>

# 1 Introduction

## 1.1 Purpose of the Quick Guide

The Quick guide provides information for safe installation and commissioning of the frequency converter.

The Quick guide is intended for use by qualified personnel. Read and follow the Quick guide to use the frequency converter safely and professionally, and pay particular attention to the safety instructions and general warnings. Keep this operating guide available with the frequency converter at all times.

## 1.2 Additional Resources

### Trane Drive Utility (TDU) support

Download the software from [www.trane.com/vfd](http://www.trane.com/vfd).

During the installation process of the software, enter CD key 52314600. A license key is not required for basic operation. For advanced features enter license key 11131111.

The latest software does not always contain the latest updates for frequency converters. Contact the local sales office for the latest frequency converter updates (in the form of \*.upd files), or download the frequency converter updates from [www.tranedrives.com](http://www.tranedrives.com).

## 1.3 Document and Software Version

The manual is regularly reviewed and updated. All suggestions for improvement are welcome.

Edition	Remarks	Software version
BAS-SVX58C-EN	Update due to new SW & HW version.	4.2

Software version 4.0x and higher introduced variable speed cooling fans for longer life and reduced fan noise under many operating conditions. Introduction of this feature required new control cards that are not compatible with older versions of software. Refer to *Table 1.1* for hardware/software compatibility.

Frame Size	Approximate date of production conversion	Old version	New version
H1, H2, H3, H4, H5	Week 26, 2018	Must use software	Must use software
H6, H7, H8, H9, H10	Week 37, 2018	version 3.xx or below	version 4.xx or higher

Table 1.1 Hardware and Software Compatibility

## 1.4 Certificates and Approvals

Certification		IP20
EC Declaration of Conformity		✓
UL Listed		✓
RCM		✓
AHRI		✓

Table 1.2 Certificates and Approvals

The frequency converter complies with UL 508C thermal memory retention requirements. For more information, refer to the section *Motor Thermal Protection* in the product-specific *design guide*.

## 1.5 Disposal

	<p>Equipment containing electrical components must not be disposed of together with domestic waste.</p> <p>It must be separately collected with electrical and electronic waste according to local and currently valid legislation.</p>
--	---

## 2 Safety

### 2.1 Safety Symbols

The following symbols are used in this document:

#### **▲WARNING**

Indicates a potentially hazardous situation that could result in death or serious injury.

#### **▲CAUTION**

Indicates a potentially hazardous situation that could result in minor or moderate injury. It can also be used to alert against unsafe practices.

#### **NOTICE**

Indicates important information, including situations that can result in damage to equipment or property.

### 2.2 Qualified Personnel

Correct and reliable transport, storage, installation, operation, and maintenance are required for the trouble-free and safe operation of the frequency converter. Only qualified personnel are allowed to install or operate this equipment.

Qualified personnel are defined as trained staff, who are authorized to install, commission, and maintain equipment, systems, and circuits in accordance with pertinent laws and regulations. Also, the personnel must be familiar with the instructions and safety measures described in this guide.

### 2.3 Safety

#### **▲WARNING**

##### **HIGH VOLTAGE**

Drives contain high voltage when connected to AC mains input, DC supply, or load sharing. Failure to perform installation, start-up, and maintenance by qualified personnel can result in death or serious injury.

- Only qualified personnel must perform installation, start-up, and maintenance.
- Before performing any service or repair work, use an appropriate voltage measuring device to make sure that there is no remaining voltage on the drive.

#### **▲WARNING**

##### **UNINTENDED START**

When the frequency converter is connected to AC mains, DC supply, or load sharing, the motor may start at any time. Unintended start during programming, service, or repair work can result in death, serious injury, or property damage. Start the motor with an external switch, a fieldbus command, an input reference signal from the local control panel (LCP), via remote operation using MCT 10 software, or after a cleared fault condition.

To prevent unintended motor start:

- Disconnect the frequency converter from the mains.
- Press [Off/Reset] on the LCP before programming parameters.
- Ensure that the frequency converter is fully wired and assembled when it is connected to AC mains, DC supply, or load sharing.

#### **▲WARNING**

##### **DISCHARGE TIME**

The frequency converter contains DC-link capacitors, which can remain charged even when the frequency converter is not powered. High voltage can be present even when the warning LED indicator lights are off. Failure to wait the specified time after power has been removed before performing service or repair work can result in death or serious injury.

- Stop the motor.
- Disconnect AC mains and remote DC-link power supplies, including battery back-ups, UPS, and DC-link connections to other frequency converters.
- Disconnect or lock PM motor.
- Wait for the capacitors to discharge fully. The minimum duration of waiting time is specified in *Table 2.1*.
- Before performing any service or repair work, use an appropriate voltage measuring device to make sure that the capacitors are fully discharged.

Voltage [V]	Power range [kW (hp)]	Minimum waiting time (minutes)
3x200	0.25–3.7 (0.33–5)	4
3x200	5.5–11 (7–15)	15
3x400	0.37–7.5 (0.5–10)	4
3x400	11–90 (15–125)	15
3x600	1.5–7.5 (2–10)	4
3x600	11–90 (15–125)	15

Table 2.1 Discharge Time

**⚠ WARNING**

**LEAKAGE CURRENT HAZARD**

Leakage currents exceed 3.5 mA. Failure to ground the drive properly can result in death or serious injury.

- Ensure the correct grounding of the equipment by a certified electrical installer.

**⚠ WARNING**

**EQUIPMENT HAZARD**

Contact with rotating shafts and electrical equipment can result in death or serious injury.

- Ensure that only trained and qualified personnel perform installation, start-up, and maintenance.
- Ensure that electrical work conforms to national and local electrical codes.
- Follow the procedures in this manual.

**⚠ CAUTION**

**INTERNAL FAILURE HAZARD**

An internal failure in the drive can result in serious injury when the drive is not properly closed.

- Ensure that all safety covers are in place and securely fastened before applying power.

2.4 Motor Thermal Protection

Set parameter 1-90 Motor Thermal Protection to [4] ETR trip 1 to enable the motor thermal protection function.

## 3 Installation

### 3.1 Mechanical Installation

#### 3.1.1 Side-by-side Installation

The frequency converter can be mounted side by side but requires the clearance above and below for cooling.

Size	IP class	Power [kW (hp)]			Clearance above/below [mm (in)]
		3x200–240 V	3x380–480 V	3x525–600 V	
<b>TR150</b>					
H1	IP20	0.25–1.5 (0.33–2)	0.37–1.5 (0.5–2)	–	100 (4)
H2	IP20	2.2 (3)	2.2–4 (3–5)	–	100 (4)
H3	IP20	3.7 (5)	5.5–7.5 (7.5–10)	–	100 (4)
H4	IP20	5.5–7.5 (7.5–10)	11–15 (15–20)	–	100 (4)
H5	IP20	11 (15)	18.5–22 (25–30)	–	100 (4)
H6	IP20	15–18.5 (20–25)	30–45 (40–60)	18.5–30 (25–40)	200 (7.9)
H7	IP20	22–30 (30–40)	55–75 (70–100)	37–55 (50–70)	200 (7.9)
H8	IP20	37–45 (50–60)	90 (125)	75–90 (100–125)	225 (8.9)
H9	IP20	–	–	2.2–7.5 (3–10)	100 (4)
H10	IP20	–	–	11–15 (15–20)	200 (7.9)
<b>TR170</b>					
H2	IP20	1.5 (2)	1.5(2)	–	100 (4)
H9	IP20	–	–	1.5 (2)	100 (4)

Table 3.1 Clearance Required for Cooling

#### **NOTICE**

With IP21/NEMA Type1 option kit mounted, a distance of 50 mm (2 in) between the units is required.

### 3.1.2 Frequency Converter Dimensions

Enclosure		Power [kW (hp)]			Height [mm (in)]			Width [mm (in)]		Depth [mm (in)]	Mounting hole [mm (in)]			Maximum weight
Size	IP class	3x 200–240 V	3x 380–480 V	3x 525–600 V	A	A <sup>1)</sup>	a	B	b	C	d	e	f	kg (lb)
<b>TR150</b>														
H1	IP20	0.25–1.5 (0.33–2.0)	0.37–1.5 (0.5–2.0)	–	195 (7.7)	273 (10.7)	183 (7.2)	75 (3.0)	56 (2.2)	168 (6.6)	9 (0.35)	4.5 (0.18)	5.3 (0.21)	2.1 (4.6)
H2	IP20	2.2 (3.0)	2.2–4.0 (3.0–5.0)	–	227 (8.9)	303 (11.9)	212 (8.3)	90 (3.5)	65 (2.6)	190 (7.5)	11 (0.43)	5.5 (0.22)	7.4 (0.29)	3.4 (7.5)
H3	IP20	3.7 (5.0)	5.5–7.5 (7.5–10)	–	255 (10.0)	329 (13.0)	240 (9.4)	100 (3.9)	74 (2.9)	206 (8.1)	11 (0.43)	5.5 (0.22)	8.1 (0.32)	4.5 (9.9)
H4	IP20	5.5–7.5 (7.5–10)	11–15 (15–20)	–	296 (11.7)	359 (14.1)	275 (10.8)	135 (5.3)	105 (4.1)	241 (9.5)	12.6 (0.50)	7 (0.28)	8.4 (0.33)	7.9 (17.4)
H5	IP20	11 (15)	18.5–22 (25–30)	–	334 (13.1)	402 (15.8)	314 (12.4)	150 (5.9)	120 (4.7)	255 (10)	12.6 (0.50)	7 (0.28)	8.5 (0.33)	9.5 (20.9)
H6	IP20	15–18.5 (20–25)	30–45 (40–60)	18.5–30 (25–40)	518 (20.4)	595 (23.4)/635 (25) (45 kW)	495 (19.5)	239 (9.4)	200 (7.9)	242 (9.5)	–	8.5 (0.33)	15 (0.6)	24.5 (54)
H7	IP20	22–30 (30–40)	55–75 (70–100)	37–55 (50–70)	550 (21.7)	630 (24.8)/690 (27.2) (75 kW)	521 (20.5)	313 (12.3)	270 (10.6)	335 (13.2)	–	8.5 (0.33)	17 (0.67)	36 (79)
H8	IP20	37–45 (50–60)	90 (125)	75–90 (100–125)	660 (26)	800 (31.5)	631 (24.8)	375 (14.8)	330 (13)	335 (13.2)	–	8.5 (0.33)	17 (0.67)	51 (112)
H9	IP20	–	–	2.2–7.5 (3.0–10)	269 (10.6)	374 (14.7)	257 (10.1)	130 (5.1)	110 (4.3)	205 (8)	11 (0.43)	5.5 (0.22)	9 (0.35)	6.6 (14.6)
H10	IP20	–	–	11–15 (15–20)	399 (15.7)	419 (16.5)	380 (15)	165 (6.5)	140 (5.5)	248 (9.8)	12 (0.47)	6.8 (0.27)	7.5 (0.30)	12 (26.5)
<b>TR170</b>														
H2	IP20	2.2 (3)	2.2–4.0 (3–5)	–	227 (8.9)	303 (11.9)	212 (8.3)	90 (3.5)	65 (2.6)	190 (7.5)	11 (0.43)	5.5 (0.22)	7.4 (0.29)	3.4 (7.5)
H9	IP20	–	–	1.5–7.5 (2–10)	269 (10.6)	374 (14.7)	257 (10.1)	130 (5.1)	110 (4.3)	205 (8.0)	11 (0.43)	5.5 (0.22)	9 (0.35)	6.6 (14.6)

<sup>1)</sup> Including decoupling plate  
 The dimensions are only for the physical units.

**NOTE**  
 When installing in an application, allow space above and below the units for cooling. The amount of space for free air passage is listed in Table 3.1.

Table 3.2 Dimensions



### 3.2 Electrical Installation

All cabling must comply with national and local regulations on cable cross-sections and ambient temperature. Copper conductors are required. 75 °C (167 °F) is recommended. For TR170 drives operating in ambients over 50 °C (122 °F), copper conductors rated 80 °C (176 °F) or higher are recommended.

**3**

Enclosure size	IP class	Power [kW (hp)]		Torque [Nm (in-lb)]					
		3x200–240 V	3x380–480 V	Mains	Motor	DC connection	Control terminals	Ground	Relay
<b>TR150</b>									
H1	IP20	0.25–1.5 (0.33–2.0)	0.37–1.5 (0.5–2.0)	0.8 (7.0)	0.8 (7.0)	0.8 (7.0)	0.5 (4.0)	0.8 (7.0)	0.5 (4.0)
H2	IP20	2.2 (3.0)	2.2–4.0 (3.0–5.0)	0.8 (7.0)	0.8 (7.0)	0.8 (7.0)	0.5 (4.0)	0.8 (7.0)	0.5 (4.0)
H3	IP20	3.7 (5.0)	5.5–7.5 (7.5–10)	0.8 (7.0)	0.8 (7.0)	0.8 (7.0)	0.5 (4.0)	0.8 (7.0)	0.5 (4.0)
H4	IP20	5.5–7.5 (7.5–10)	11–15 (15–20)	1.2 (11)	1.2 (11)	1.2 (11)	0.5 (4.0)	0.8 (7.0)	0.5 (4.0)
H5	IP20	11 (15)	18.5–22 (25–30)	1.2 (11)	1.2 (11)	1.2 (11)	0.5 (4.0)	0.8 (7.0)	0.5 (4.0)
H6	IP20	15–18.5 (20–25)	30–45 (40–60)	4.5 (40)	4.5 (40)	–	0.5 (4.0)	3 (27)	0.5 (4.0)
H7	IP20	22–30 (30–40)	55 (70)	10 (89)	10 (89)	–	0.5 (4.0)	3 (27)	0.5 (4.0)
H7	IP20	–	75 (100)	14 (124)	14 (124)	–	0.5 (4.0)	3 (27)	0.5 (4.0)
H8	IP20	37–45 (50–60)	90 (125)	24 (212) <sup>1)</sup>	24 (212) <sup>1)</sup>	–	0.5 (4.0)	3 (27)	0.5 (4.0)
<b>TR170</b>									
H2	IP20	1.5 (2.0)	1.5 (2.0)	0.8 (7.0)	0.8 (7.0)	0.8 (7.0)	0.5 (4.0)	0.8 (7.0)	0.5 (4.0)

**Table 3.3 Tightening Torques for Enclosure Sizes H1–H8, 3x200–240 V & 3x380–480 V**

Enclosure size	IP class	Power [kW (hp)]		Torque [N · m (in-lb)]					
		3x525–600 V	Mains	Motor	DC connection	Control terminals	Ground	Relay	
<b>TR150</b>									
H9	IP20	2.2–7.5 (3.0–10)	1.8 (16)	1.8 (16)	Not recommended	0.5 (4.0)	3 (27)	0.6 (5.0)	
H10	IP20	11–15 (15–20)	1.8 (16)	1.8 (16)	Not recommended	0.5 (4.0)	3 (27)	0.6 (5.0)	
H6	IP20	18.5–30 (25–40)	4.5 (40)	4.5 (40)	–	0.5 (4.0)	3 (27)	0.5 (4.0)	
H7	IP20	37–55 (50–70)	10 (89)	10 (89)	–	0.5 (4.0)	3 (27)	0.5 (4.0)	
H8	IP20	75–90 (100–125)	14 (124)/24 (212) <sup>2)</sup>	14 (124)/24 (212) <sup>2)</sup>	–	0.5 (4.0)	3 (27)	0.5 (4.0)	
<b>TR170</b>									
H9	IP20	1.5 (2.0)	1.8 (16)	1.8 (16)	Not recommended	0.5 (4.0)	3 (27)	0.6 (5.0)	

**Table 3.4 Tightening Torques for Enclosure Sizes H6–H10, 3x525–600 V**

1) Cable dimensions >95 mm<sup>2</sup>

2) Cable dimensions ≤95 mm<sup>2</sup>

### 3.2.1 IT Mains

## CAUTION

### IT Mains

Installation on isolated mains source, that is, IT mains. Ensure that the supply voltage does not exceed 440 V (3x380–480 V units) when connected to mains.

On IP20, 200–240 V, 0.25–11 kW (0.33–15 hp) and 380–480 V, IP20, 0.37–22 kW (0.5–30 hp) units, open the RFI switch by removing the screw on the side of the frequency converter when at IT grid.

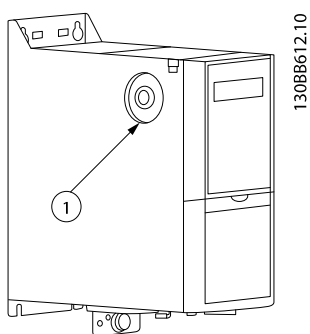

1	EMC screw
---	-----------

Illustration 3.1 IP20, 200–240 V, 0.25–11 kW (0.33–15 hp), IP20, 0.37–22 kW (0.5–30 hp), 380–480 V

On 400 V, 30–90 kW (40–125 hp) and 600 V units, set parameter 14-50 RFI Filter to [0] Off when operating in IT mains.

For IP54, 400 V, 0.75–18.5 kW (1.0–25 hp) units, the EMC screw is inside the frequency converter, as shown in Illustration 3.2.

## NOTICE

If reinserted, use only M3x12 screw.

### 3.2.2 Connecting to Mains and Motor

The frequency converter is designed to operate all standard 3-phase asynchronous motors. For maximum cross-section on cables, see chapter 6.4 General Technical Data.

- Use a shielded/armored motor cable to comply with EMC emission specifications and connect this cable to both the decoupling plate and the motor.
- Keep the motor cable as short as possible to reduce the noise level and leakage currents.

- For further details on mounting the decoupling plate, see *Decoupling Plate Mounting Instruction*.
  - Also see *EMC-Correct Installation* in the *TR150 and TR170 Design Guide*.
1. Mount the ground cables to the ground terminal.
  2. Connect the motor to terminals U, V, and W, and then tighten the screws according to the torques specified in chapter 3.2.1 *Electrical Installation in General*.
  3. Connect the mains supply to terminals L1, L2, and L3, and then tighten the screws according to the torques specified in chapter 3.2.1 *Electrical Installation in General*.

### Relays and terminals on enclosure sizes H1–H5

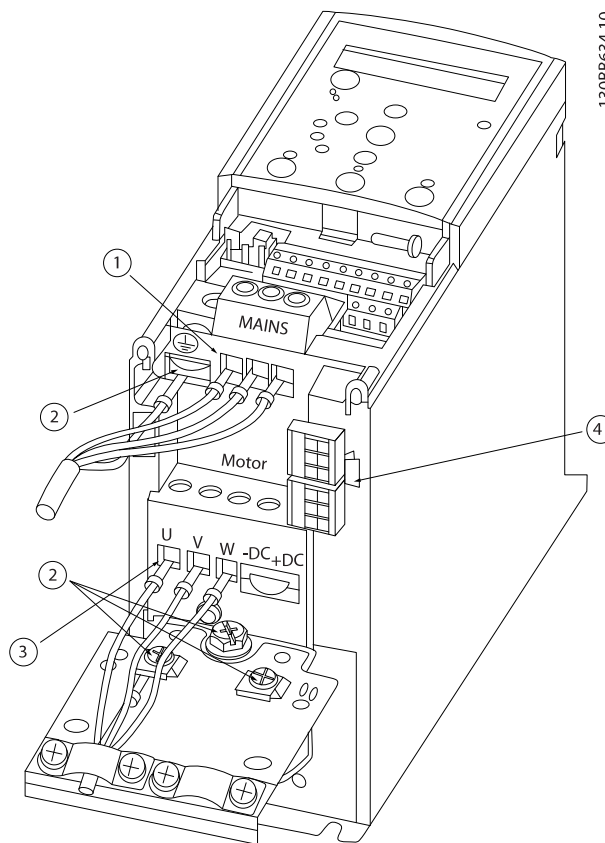

1	Mains
2	Ground
3	Motor
4	Relays

Illustration 3.2 Enclosure Sizes H1–H5  
IP20, 200–240 V, 0.25–11 kW (0.33–15 hp)  
IP20, 380–480 V, 0.37–22 kW (0.5–30 hp)

## Installation

3

Relays and terminals on enclosure size H6

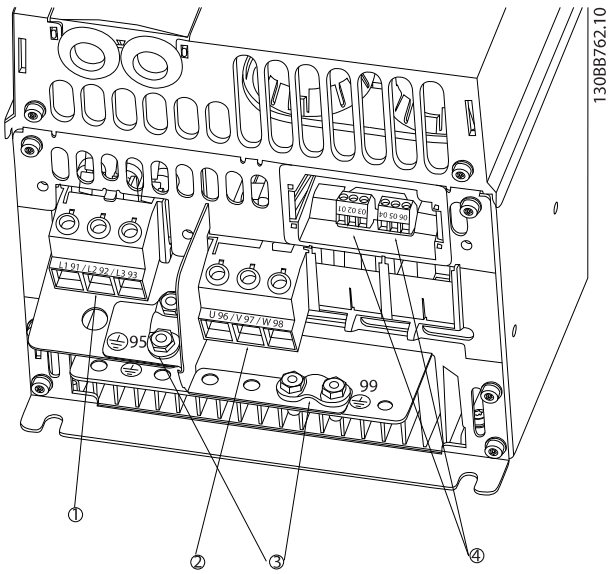

1	Mains
2	Motor
3	Ground
4	Relays

Illustration 3.3 Enclosure Size H6

IP20, 380–480 V, 30–45 kW (40–60 hp)  
 IP20, 200–240 V, 15–18.5 kW (20–25 hp)  
 IP20, 525–600 V, 22–30 kW (30–40 hp)

Relays and terminals on enclosure size H7

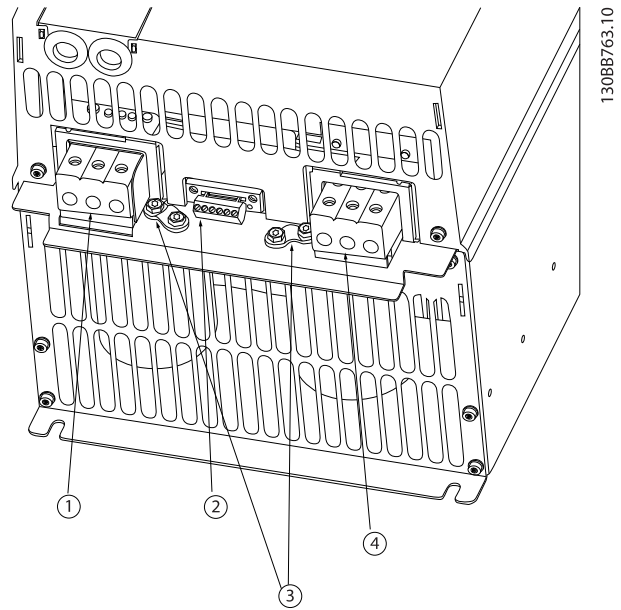

1	Mains
2	Relays
3	Ground
4	Motor

Illustration 3.4 Enclosure Size H7

IP20, 380–480 V, 55–75 kW (70–100 hp)  
 IP20, 200–240 V, 22–30 kW (30–40 hp)  
 IP20, 525–600 V, 45–55 kW (60–70 hp)

Relays and terminals on enclosure size H8

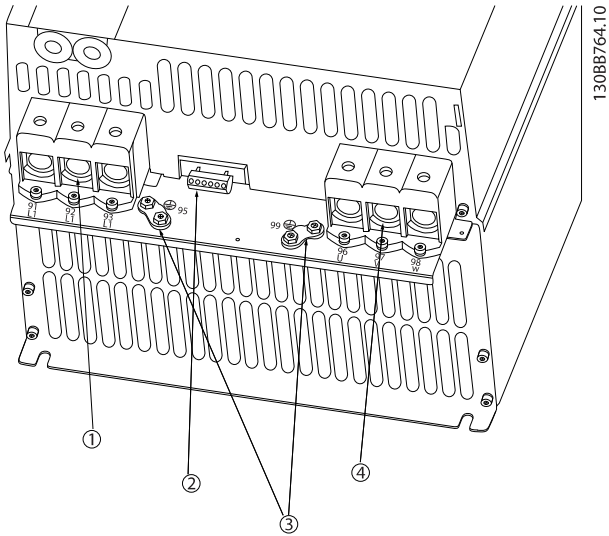

1	Mains
2	Relays
3	Ground
4	Motor

**Illustration 3.5 Enclosure Size H8**  
 IP20, 380–480 V, 90 kW (125 hp)  
 IP20, 200–240 V, 37–45 kW (50–60 hp)  
 IP20, 525–600 V, 75–90 kW (100–125 hp)

Connecting to mains and motor for enclosure size H9

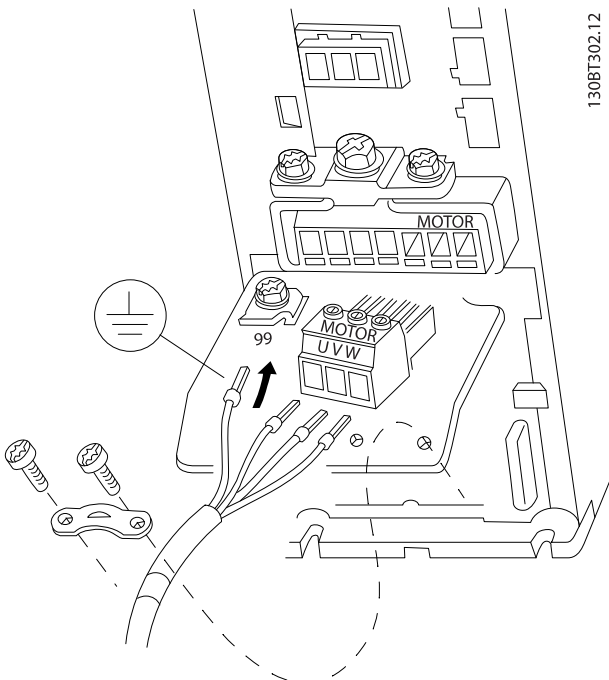

**Illustration 3.6 Connecting the Frequency Converter to the Motor, Enclosure Size H9**  
 IP20, 600 V, 1.5–7.5 kW (2.0–10 hp)

Complete the following steps to connect the mains cables for enclosure size H9. Use the tightening torques described in chapter 3.2.1 *Electrical Installation in General*.

1. Slide the mounting plate into place and tighten the 2 screws as shown in *Illustration 3.7*.

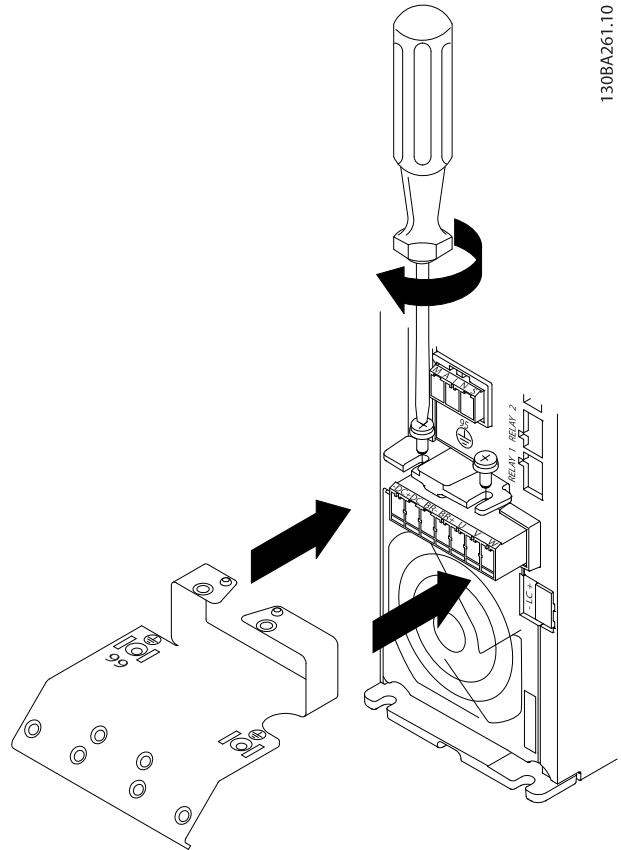

**Illustration 3.7 Mounting the Mounting Plate**

## Installation

3

2. Mount the ground cable as shown in *Illustration 3.8*.

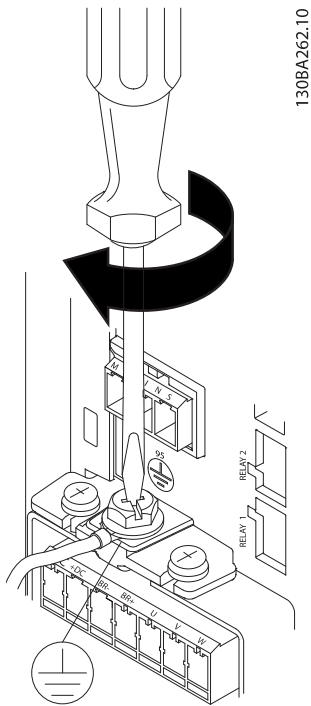

Illustration 3.8 Mounting the Ground Cable

3. Insert the mains cables to the mains plug and tighten the screws as shown in *Illustration 3.9*.

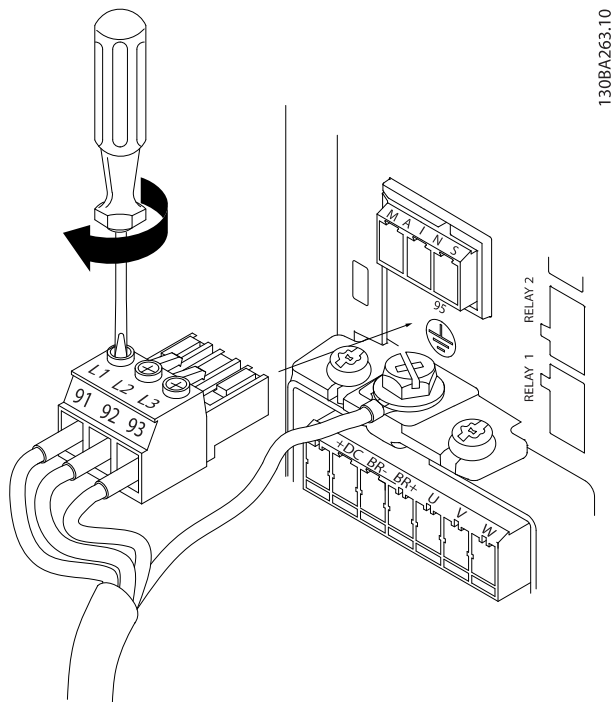

Illustration 3.9 Mounting the Mains Plug

4. Mount the support bracket across the mains cables and tighten the screws as shown in *Illustration 3.10*.

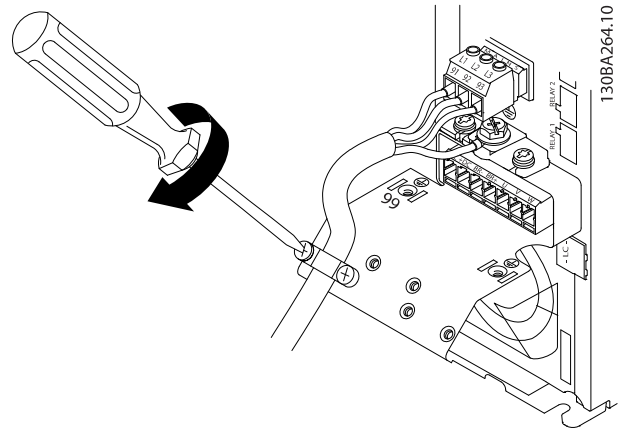

Illustration 3.10 Mounting the Support Bracket

### Relays and terminals on enclosure size H10

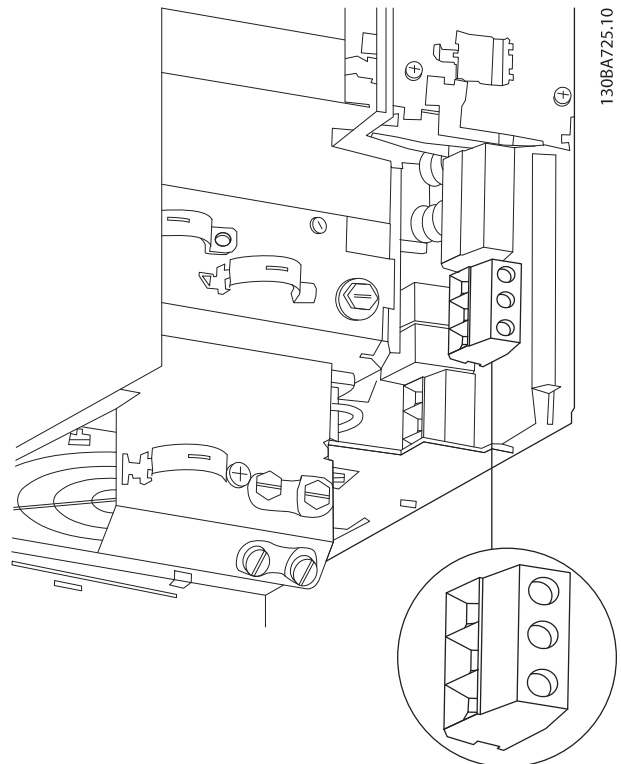

Illustration 3.11 Enclosure Size H10  
IP20, 600 V, 11–15 kW (15–20 hp)

### 3.2.3 Fuses and Circuit Breakers

#### Branch circuit protection

To prevent fire hazards, protect the branch circuits in an installation - switch gear, machines, and so on - against short circuits and overcurrent. Follow national and local regulations.

#### Overcurrent protection

Provide overload protection to avoid overheating of the cables in the installation. Overcurrent protection must always be carried out according to local and national regulations. Circuit breakers and fuses must be designed for protection in a circuit capable of supplying a maximum of 100000  $A_{rms}$ (symmetrical), 480 V maximum.

#### UL/Non-UL compliance

To ensure compliance with UL or IEC 61800-5-1, use the circuit breakers or fuses listed in *Table 3.5*.

Circuit breakers must be designed for protection in a circuit capable of supplying a maximum of 10000  $A_{rms}$  (symmetrical), 480 V maximum.

#### **NOTICE**

In the event of malfunction, failure to follow the protection recommendation may result in damage to the frequency converter.

Power [kW (hp)]	Circuit breaker		Fuse						
	UL	Non-UL	UL				Non-UL		
			Bussmann Type RK5	Bussmann Type RK1	Bussmann Type J	Bussmann Type T	Max fuse Type G		
<b>3x200–240 V IP20</b>									
0.25 (0.33)	-	-	FRS-R-10	KTN-R10	JKS-10	JJN-10	10		
0.37 (0.5)			FRS-R-10	KTN-R10	JKS-10	JJN-10	10		
0.75 (1.0)			FRS-R-10	KTN-R10	JKS-10	JJN-10	10		
1.5 (2.0)			FRS-R-10	KTN-R10	JKS-10	JJN-10	10		
2.2 (3.0)			FRS-R-15	KTN-R15	JKS-15	JJN-15	16		
3.7 (5.0)			FRS-R-25	KTN-R25	JKS-25	JJN-25	25		
5.5 (7.5)			FRS-R-50	KTN-R50	JKS-50	JJN-50	50		
7.5 (10)			FRS-R-50	KTN-R50	JKS-50	JJN-50	50		
11 (15)			FRS-R-80	KTN-R80	JKS-80	JJN-80	65		
15 (20)			Cutler-Hammer EGE3100FFG	Moeller NZMB1- A125	FRS-R-100	KTN-R100	JKS-100	JJN-100	125
18.5 (25)			FRS-R-100	KTN-R100	JKS-100	JJN-100	125		
22 (30)	Cutler-Hammer JGE3150FFG	Moeller NZMB1- A160	FRS-R-150	KTN-R150	JKS-150	JJN-150	160		
30 (40)			FRS-R-150	KTN-R150	JKS-150	JJN-150	160		
37 (50)	Cutler-Hammer JGE3200FFG	Moeller NZMB1- A200	FRS-R-200	KTN-R200	JKS-200	JJN-200	200		
45 (60)			FRS-R-200	KTN-R200	JKS-200	JJN-200	200		
<b>3x380–480 V IP20</b>									
0.37 (0.5)	-	-	FRS-R-10	KTS-R10	JKS-10	JJS-10	10		
0.75 (1.0)			FRS-R-10	KTS-R10	JKS-10	JJS-10	10		
1.5 (2.0)			FRS-R-10	KTS-R10	JKS-10	JJS-10	10		
2.2 (3.0)			FRS-R-15	KTS-R15	JKS-15	JJS-15	16		
3.0 (4.0)			FRS-R-15	KTS-R15	JKS-15	JJS-15	16		
4.0 (5.0)			FRS-R-15	KTS-R15	JKS-15	JJS-15	16		
5.5 (7.5)			FRS-R-25	KTS-R25	JKS-25	JJS-25	25		
7.5 (10)			FRS-R-25	KTS-R25	JKS-25	JJS-25	25		
11 (15)			FRS-R-50	KTS-R50	JKS-50	JJS-50	50		
15 (20)			FRS-R-50	KTS-R50	JKS-50	JJS-50	50		
18.5 (25)			FRS-R-80	KTS-R80	JKS-80	JJS-80	65		
22 (30)			FRS-R-80	KTS-R80	JKS-80	JJS-80	65		
30 (40)			Cutler-Hammer EGE3125FFG	Moeller NZMB1- A125	FRS-R-125	KTS-R125	JKS-R125	JJS-R125	80
37 (50)					FRS-R-125	KTS-R125	JKS-R125	JJS-R125	100
45 (60)					FRS-R-125	KTS-R125	JKS-R125	JJS-R125	125

	Circuit breaker		Fuse				
	UL	Non-UL	UL				Non-UL
Power [kW (hp)]			Bussmann Type RK5	Bussmann Type RK1	Bussmann Type J	Bussmann Type T	Max fuse Type G
55 (70)	Cutler-Hammer JGE3200FFG	Moeller NZMB1- A200	FRS-R-200	KTS-R200	JKS-R200	JJS-R200	150
75 (100)			FRS-R-200	KTS-R200	JKS-R200	JJS-R200	200
90 (125)	Cutler-Hammer JGE3250FFG	Moeller NZMB2- A250	FRS-R-250	KTS-R250	JKS-R250	JJS-R250	250
<b>3x525–600 V IP20</b>							
1.5 (2.0)	-	-	FRS-R-20	KTS-R20	JKS-20	JJS-20	20
2.2 (3.0)			FRS-R-20	KTS-R20	JKS-20	JJS-20	20
3.0 (4.0)			FRS-R-20	KTS-R20	JKS-20	JJS-20	20
3.7 (5.0)			FRS-R-20	KTS-R20	JKS-20	JJS-20	20
5.5 (7.5)			FRS-R-20	KTS-R20	JKS-20	JJS-20	20
7.5 (10)			FRS-R-20	KTS-R20	JKS-20	JJS-20	30
11 (15)	-	-	FRS-R-30	KTS-R30	JKS-30	JJS-30	35
15 (20)			FRS-R-30	KTS-R30	JKS-30	JJS-30	35
18.5 (25)	Cutler-Hammer EGE3080FFG	Cutler-Hammer EGE3080FFG	FRS-R-80	KTS-R80	JKS-80	JJS-80	80
22 (30)			FRS-R-80	KTS-R80	JKS-80	JJS-80	80
30 (40)			FRS-R-80	KTS-R80	JKS-80	JJS-80	80
37 (50)	Cutler-Hammer JGE3125FFG	Cutler-Hammer JGE3125FFG	FRS-R-125	KTS-R125	JKS-125	JJS-125	125
45 (60)			FRS-R-125	KTS-R125	JKS-125	JJS-125	125
55 (70)			FRS-R-125	KTS-R125	JKS-125	JJS-125	125
75 (100)	Cutler-Hammer JGE3200FAG	Cutler-Hammer JGE3200FAG	FRS-R-200	KTS-R200	JKS-200	JJS-200	200
90 (125)		-	FRS-R-200	KTS-R200	JKS-200	JJS-200	200

**Table 3.5 Circuit Breaker and Fuses**

### 3.2.4 EMC-correct Electrical Installation

General points to be observed to ensure EMC-correct electrical installation:

- Use only shielded/armored motor cables and shielded/armored control cables.
- Ground the shield at both ends.
- Avoid installation with twisted shield ends (pigtailed), because it reduces the shielding effect at high frequencies. Use the cable clamps provided.
- Ensure the same potential between the frequency converter and the ground potential of PLC.
- Use star washers and galvanically conductive installation plates.

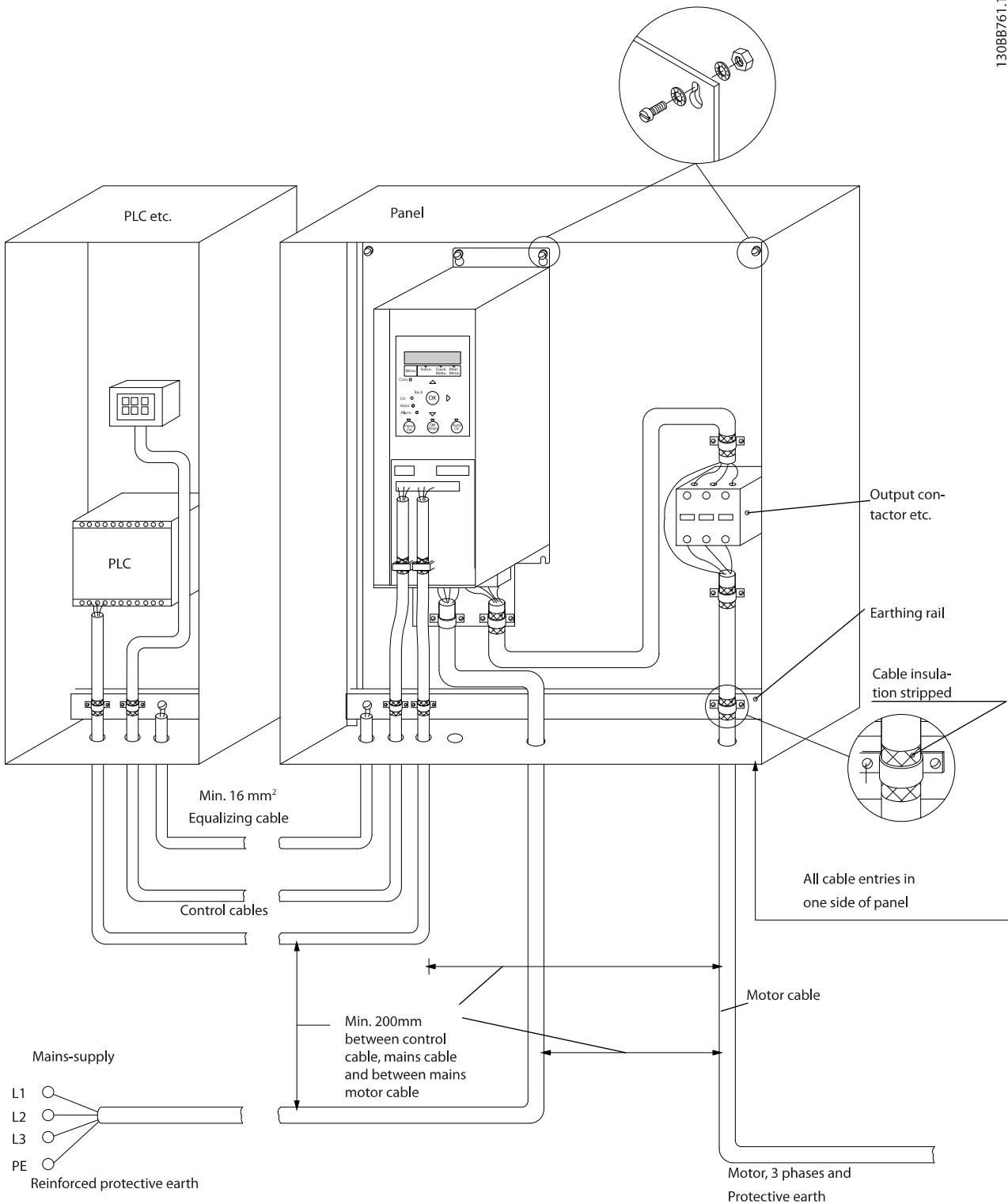

Illustration 3.12 EMC-correct Electrical Installation



### 3.2.5 Control Terminals

Remove the terminal cover to access the control terminals.

Use a flat-edged screwdriver to push down the lock lever of the terminal cover under the LCP, then remove the terminal cover as shown in *Illustration 3.13*.

For IP20 units, remove the front cover after the terminal cover is removed.

3

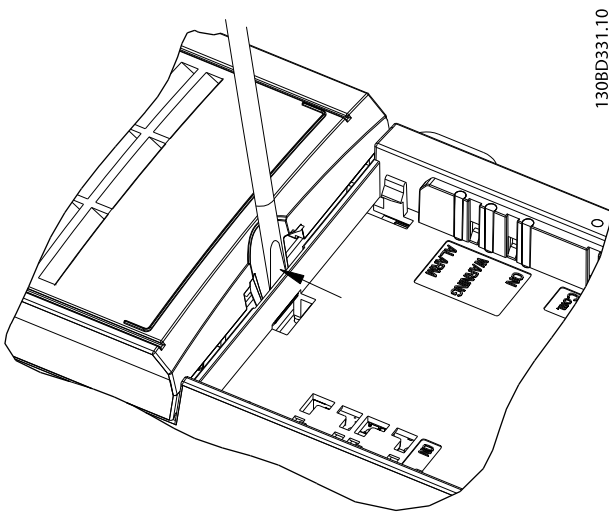

Illustration 3.13 Removing the Terminal Cover

*Illustration 3.14* shows all the frequency converter control terminals. Applying start (terminal 18), connection between terminals 12-27, and an analog reference (terminal 53 or 54, and 55) make the frequency converter run.

The digital input mode of terminal 18, 19, and 27 is set in *parameter 5-00 Digital Input Mode* (PNP is default value). Digital input 29 mode is set in *parameter 5-03 Digital Input 29 Mode* (PNP is default value).

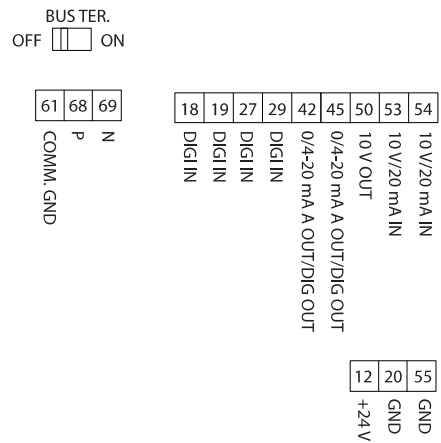

Illustration 3.14 Control Terminals

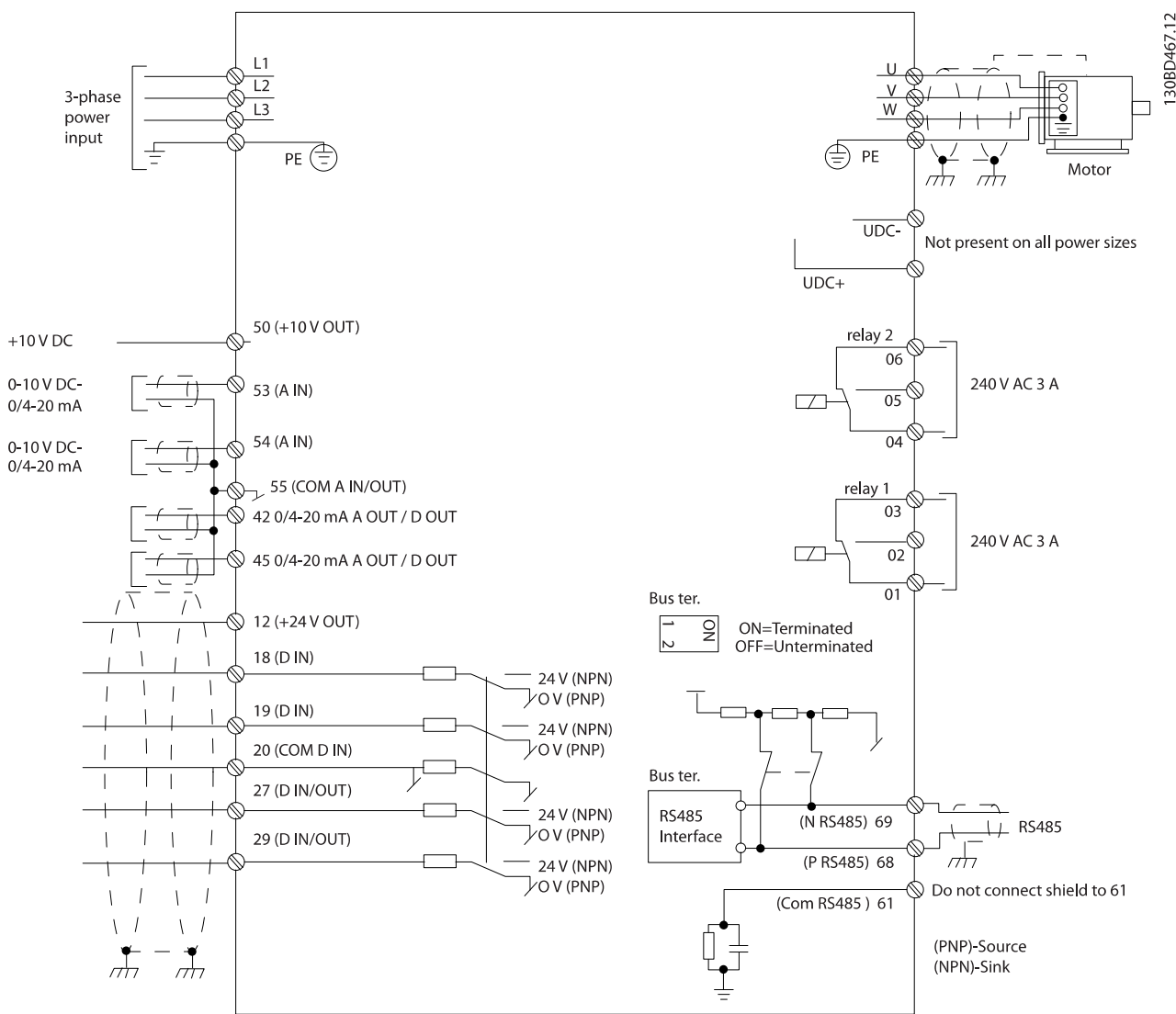

Illustration 3.15 Basic Wiring Schematic Drawing

**NOTICE**

There is no access to UDC- and UDC+ on the following units:

- IP20, 380–480 V, 30–90 kW (40–125 hp)
- IP20, 200–240 V, 15–45 kW (20–60 hp)
- IP20, 525–600 V, 1.5–90 kW (2.0–125 hp)
- IP54, 380–480 V, 22–90 kW (30–125 hp)

3.2.6 Acoustic Noise or Vibration

If the motor or the equipment driven by the motor - for example, a fan - is making noise or vibrations at certain frequencies, configure the following parameters or parameter groups to reduce or eliminate the noise or vibrations:

- *Parameter group 4-6\* Speed Bypass.*
- *Set parameter 14-03 Overmodulation to [0] Off.*

- *Switching pattern and switching frequency parameter group 14-0\* Inverter Switching.*
- *Parameter 1-64 Resonance Damping.*

## 4 Programming

### 4.1 Keypad

The frequency converter can be programmed from the Keypad or from a PC via the RS485 COM port by installing the Trane Drive Utility (TDU). Refer to *chapter 1.2 Additional Resources* for more details about the software.

The keypad is divided into 4 functional sections.

- A. Display
- B. Menu key
- C. Navigation keys and indicator lights
- D. Operation keys and indicator lights

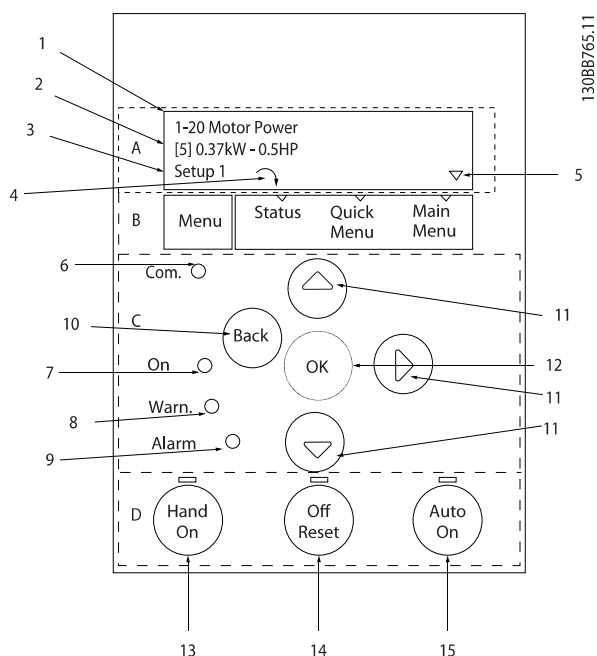

Illustration 4.1 Keypad

#### A. Display

The LCD display is illuminated with 2 alphanumeric lines. All data is shown on the keypad.

Illustration 4.1 describes the information that can be read from the display.

1	Parameter number and name.
2	Parameter value.
3	Set-up number shows the active set-up and the edit set-up. If the same set-up acts as both active and edit set-up, only that set-up number is shown (factory setting). When active and edit set-up differ, both numbers are shown in the display (set-up 12). The number flashing indicates the edit set-up.
4	Motor direction is shown to the bottom left of the display – indicated by a small arrow pointing either clockwise or counterclockwise.
5	The triangle indicates if the keypad is in Status, Quick Menu, or Main Menu.

Table 4.1 Legend to Illustration 4.1, Part I

#### B. Menu key

Press [Menu] to select among Status, Quick Menu, or Main Menu.

#### C. Navigation keys and indicator lights

6	Com. LED: Flashes during bus communication.
7	Green LED/On: Control section is working correctly.
8	Yellow LED/Warn.: Indicates a warning.
9	Flashing Red LED/Alarm: Indicates an alarm.
10	[Back]: For moving to the previous step or layer in the navigation structure.
11	[▲] [▼] [▶] [◀]: For navigating among parameter groups and parameters, and within parameters. They can also be used for setting local reference.
12	[OK]: For selecting a parameter and for accepting changes to parameter settings.

Table 4.2 Legend to Illustration 4.1, Part II

#### D. Operation keys and indicator lights

13	[Hand On]: Starts the motor and enables control of the frequency converter via the keypad. <b>NOTICE</b> [2] Coast inverse is the default option for parameter 5-12 Terminal 27 Digital Input. If there is no 24 V supply to terminal 27, [Hand On] does not start the motor. Connect terminal 12 to terminal 27.
14	[Off/Reset]: Stops the motor (Off). If in alarm mode, the alarm is reset.
15	[Auto On]: The frequency converter is controlled either via control terminals or serial communication.

Table 4.3 Legend to Illustration 4.1, Part III

## 4.2 Set-up Wizard

The built-in wizard menu guides the installer through the set-up of the frequency converter in a clear and structured manner for open-loop applications, closed-loop applications, and quick motor settings.

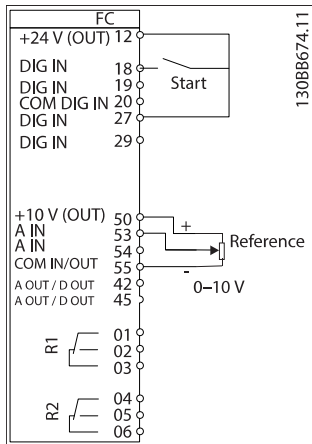

Illustration 4.2 Frequency Converter Wiring

The wizard is shown after power-up until any parameter has been changed. The wizard can always be accessed again through the quick menu. Press [OK] to start the wizard. Press [Back] to return to the status view.

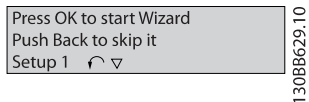

Illustration 4.3 Start-up/Quit Wizard

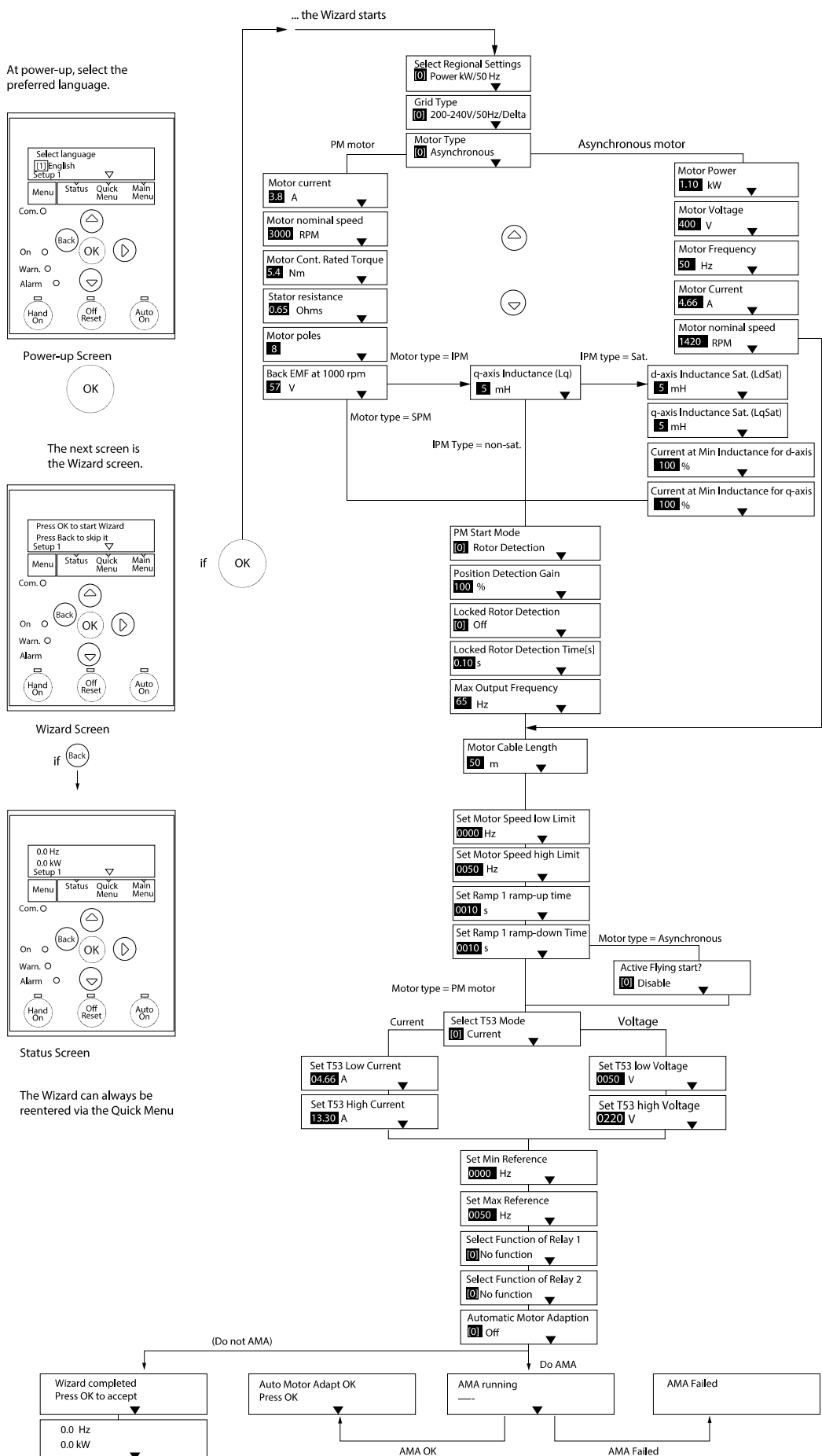

Illustration 4.4 Set-up Wizard for Open-loop Applications

Set-up Wizard for Open-loop Applications

Parameter	Option	Default	Usage
Parameter 0-03 Regional Settings	[0] International [1] US	[0] International	–
Parameter 0-06 GridType	[0] 200–240 V/50 Hz/IT-grid [1] 200–240 V/50 Hz/Delta [2] 200–240 V/50 Hz [10] 380–440 V/50 Hz/IT-grid [11] 380–440 V/50 Hz/Delta [12] 380–440 V/50 Hz [20] 440–480 V/50 Hz/IT-grid [21] 440–480 V/50 Hz/Delta [22] 440–480 V/50 Hz [30] 525–600 V/50 Hz/IT-grid [31] 525–600 V/50 Hz/Delta [32] 525–600 V/50 Hz [100] 200–240 V/60 Hz/IT-grid [101] 200–240 V/60 Hz/Delta [102] 200–240 V/60 Hz [110] 380–440 V/60 Hz/IT-grid [111] 380–440 V/60 Hz/Delta [112] 380–440 V/60 Hz [120] 440–480 V/60 Hz/IT-grid [121] 440–480 V/60 Hz/Delta [122] 440–480 V/60 Hz [130] 525–600 V/60 Hz/IT-grid [131] 525–600 V/60 Hz/Delta [132] 525–600 V/60 Hz	Size related	Select the operating mode for restart after reconnection of the frequency converter to mains voltage after power-down.

Parameter	Option	Default	Usage
Parameter 1-10 Motor Construction	*[0] Asynchron [1] PM, non-salient SPM [3] PM, salient IPM	[0] Asynchron	Setting the parameter value might change these parameters: <ul style="list-style-type: none"> <li>• Parameter 1-01 Motor Control Principle.</li> <li>• Parameter 1-03 Torque Characteristics.</li> <li>• Parameter 1-08 Motor Control Bandwidth.</li> <li>• Parameter 1-14 Damping Gain.</li> <li>• Parameter 1-15 Low Speed Filter Time Const.</li> <li>• Parameter 1-16 High Speed Filter Time Const.</li> <li>• Parameter 1-17 Voltage filter time const.</li> <li>• Parameter 1-20 Motor Power.</li> <li>• Parameter 1-22 Motor Voltage.</li> <li>• Parameter 1-23 Motor Frequency.</li> <li>• Parameter 1-24 Motor Current.</li> <li>• Parameter 1-25 Motor Nominal Speed.</li> <li>• Parameter 1-26 Motor Cont. Rated Torque.</li> <li>• Parameter 1-30 Stator Resistance (Rs).</li> <li>• Parameter 1-33 Stator Leakage Reactance (X1).</li> <li>• Parameter 1-35 Main Reactance (Xh).</li> <li>• Parameter 1-37 d-axis Inductance (Ld).</li> <li>• Parameter 1-38 q-axis Inductance (Lq).</li> <li>• Parameter 1-39 Motor Poles.</li> <li>• Parameter 1-40 Back EMF at 1000 RPM.</li> <li>• Parameter 1-44 d-axis Inductance Sat. (LdSat).</li> <li>• Parameter 1-45 q-axis Inductance Sat. (LqSat).</li> <li>• Parameter 1-46 Position Detection Gain.</li> <li>• Parameter 1-48 Current at Min Inductance for d-axis.</li> <li>• Parameter 1-49 Current at Min Inductance for q-axis.</li> <li>• Parameter 1-66 Min. Current at Low Speed.</li> <li>• Parameter 1-70 Start Mode.</li> <li>• Parameter 1-72 Start Function.</li> <li>• Parameter 1-73 Flying Start.</li> <li>• Parameter 1-80 Function at Stop.</li> <li>• Parameter 1-82 Min Speed for Function at Stop [Hz].</li> <li>• Parameter 1-90 Motor Thermal Protection.</li> <li>• Parameter 2-00 DC Hold/Motor Preheat Current.</li> <li>• Parameter 2-01 DC Brake Current.</li> <li>• Parameter 2-02 DC Braking Time.</li> <li>• Parameter 2-04 DC Brake Cut In Speed.</li> <li>• Parameter 2-10 Brake Function.</li> <li>• Parameter 4-14 Motor Speed High Limit [Hz].</li> <li>• Parameter 4-19 Max Output Frequency.</li> <li>• Parameter 4-58 Missing Motor Phase Function.</li> <li>• Parameter 14-65 Speed Derate Dead Time Compensation.</li> </ul>

Parameter	Option	Default	Usage
Parameter 1-20 Motor Power	0.12–110 kW/0.16–150 hp	Size related	Enter the motor power from the nameplate data.
Parameter 1-22 Motor Voltage	50–1000 V	Size related	Enter the motor voltage from the nameplate data.
Parameter 1-23 Motor Frequency	20–400 Hz	Size related	Enter the motor frequency from the nameplate data.
Parameter 1-24 Motor Current	0.01–10000.00 A	Size related	Enter the motor current from the nameplate data.
Parameter 1-25 Motor Nominal Speed	50–9999 RPM	Size related	Enter the motor nominal speed from the nameplate data.
Parameter 1-26 Motor Cont. Rated Torque	0.1–1000.0 Nm	Size related	This parameter is available when <i>parameter 1-10 Motor Construction</i> is set to options that enable permanent magnet motor mode. <b>NOTICE</b> Changing this parameter affects the settings of other parameters.
Parameter 1-29 Automatic Motor Adaption (AMA)	See <i>parameter 1-29 Automatic Motor Adaption (AMA)</i> .	Off	Performing an AMA optimizes motor performance.
Parameter 1-30 Stator Resistance (Rs)	0.000–99.990 Ω	Size related	Set the stator resistance value.
Parameter 1-37 d-axis Inductance (Ld)	0.000–1000.000 mH	Size related	Enter the value of the d-axis inductance. Obtain the value from the permanent magnet motor datasheet.
Parameter 1-38 q-axis Inductance (Lq)	0.000–1000.000 mH	Size related	Enter the value of the q-axis inductance.
Parameter 1-39 Motor Poles	2–100	4	Enter the number of motor poles.
Parameter 1-40 Back EMF at 1000 RPM	10–9000 V	Size related	Line-line RMS back EMF voltage at 1000 RPM.
Parameter 1-42 Motor Cable Length	0–100 m	50 m	Enter the motor cable length.
Parameter 1-44 d-axis Inductance Sat. (LdSat)	0.000–1000.000 mH	Size related	This parameter corresponds to the inductance saturation of Ld. Ideally, this parameter has the same value as <i>parameter 1-37 d-axis Inductance (Ld)</i> . However, if the motor supplier provides an induction curve, enter the induction value, which is 200% of the nominal current.
Parameter 1-45 q-axis Inductance Sat. (LqSat)	0.000–1000.000 mH	Size related	This parameter corresponds to the inductance saturation of Lq. Ideally, this parameter has the same value as <i>parameter 1-38 q-axis Inductance (Lq)</i> . However, if the motor supplier provides an induction curve, enter the induction value, which is 200% of the nominal current.
Parameter 1-46 Position Detection Gain	20–200%	100%	Adjusts the height of the test pulse during position detection at start.
Parameter 1-48 Current at Min Inductance for d-axis	20–200%	100%	Enter the inductance saturation point.
Parameter 1-49 Current at Min Inductance for q-axis	20–200%	100%	This parameter specifies the saturation curve of the d- and q-inductance values. From 20–100% of this parameter, the inductances are linearly approximated due to <i>parameter 1-37 d-axis Inductance (Ld)</i> , <i>parameter 1-38 q-axis Inductance (Lq)</i> , <i>parameter 1-44 d-axis Inductance Sat. (LdSat)</i> , and <i>parameter 1-45 q-axis Inductance Sat. (LqSat)</i> .
Parameter 1-70 Start Mode	[0] Rotor Detection [1] Parking	[0] Rotor Detection	Select the PM motor start mode.



## Programming

4

Parameter	Option	Default	Usage
Parameter 1-73 Flying Start	[0] Disabled [1] Enabled	[0] Disabled	Select [1] Enabled to enable the frequency converter to catch a motor spinning due to mains drop-out. Select [0] Disabled if this function is not required. When this parameter is set to [1] Enabled, parameter 1-71 Start Delay and parameter 1-72 Start Function are not functional. Parameter 1-73 Flying Start is active in VVC <sup>+</sup> mode only.
Parameter 3-02 Minimum Reference	-4999.000–4999.000	0	The minimum reference is the lowest value obtainable by summing all references.
Parameter 3-03 Maximum Reference	-4999.000–4999.000	50	The maximum reference is the highest value obtainable by summing all references.
Parameter 3-41 Ramp 1 Ramp Up Time	0.05–3600.00 s	Size related	If asynchronous motor is selected, the ramp-up time is from 0 to rated parameter 1-23 Motor Frequency. If PM motor is selected, the ramp-up time is from 0 to parameter 1-25 Motor Nominal Speed.
Parameter 3-42 Ramp 1 Ramp Down Time	0.05–3600.00 s	Size related	For asynchronous motors, the ramp-down time is from rated parameter 1-23 Motor Frequency to 0. For PM motors, the ramp-down time is from parameter 1-25 Motor Nominal Speed to 0.
Parameter 4-12 Motor Speed Low Limit [Hz]	0.0–400.0 Hz	0 Hz	Enter the minimum limit for low speed.
Parameter 4-14 Motor Speed High Limit [Hz]	0.0–400.0 Hz	100 Hz	Enter the maximum limit for high speed.
Parameter 4-19 Max Output Frequency	0.0–400.0 Hz	100 Hz	Enter the maximum output frequency value. If parameter 4-19 Max Output Frequency is set lower than parameter 4-14 Motor Speed High Limit [Hz], parameter 4-14 Motor Speed High Limit [Hz] is set equal to parameter 4-19 Max Output Frequency automatically.
Parameter 5-40 Function Relay	See parameter 5-40 Function Relay.	[9] Alarm	Select the function to control output relay 1.
Parameter 5-40 Function Relay	See parameter 5-40 Function Relay.	[5] Drive running	Select the function to control output relay 2.
Parameter 6-10 Terminal 53 Low Voltage	0.00–10.00 V	0.07 V	Enter the voltage that corresponds to the low reference value.
Parameter 6-11 Terminal 53 High Voltage	0.00–10.00 V	10 V	Enter the voltage that corresponds to the high reference value.
Parameter 6-12 Terminal 53 Low Current	0.00–20.00 mA	4 mA	Enter the current that corresponds to the low reference value.
Parameter 6-13 Terminal 53 High Current	0.00–20.00 mA	20 mA	Enter the current that corresponds to the high reference value.
Parameter 6-19 Terminal 53 mode	[0] Current [1] Voltage	[1] Voltage	Select if terminal 53 is used for current or voltage input.
Parameter 30-22 Locked Rotor Protection	[0] Off [1] On	[0] Off	–
Parameter 30-23 Locked Rotor Detection Time [s]	0.05–1 s	0.10 s	–

Table 4.4 Set-up Wizard for Open-loop Applications

Set-up Wizard for Closed-loop Applications

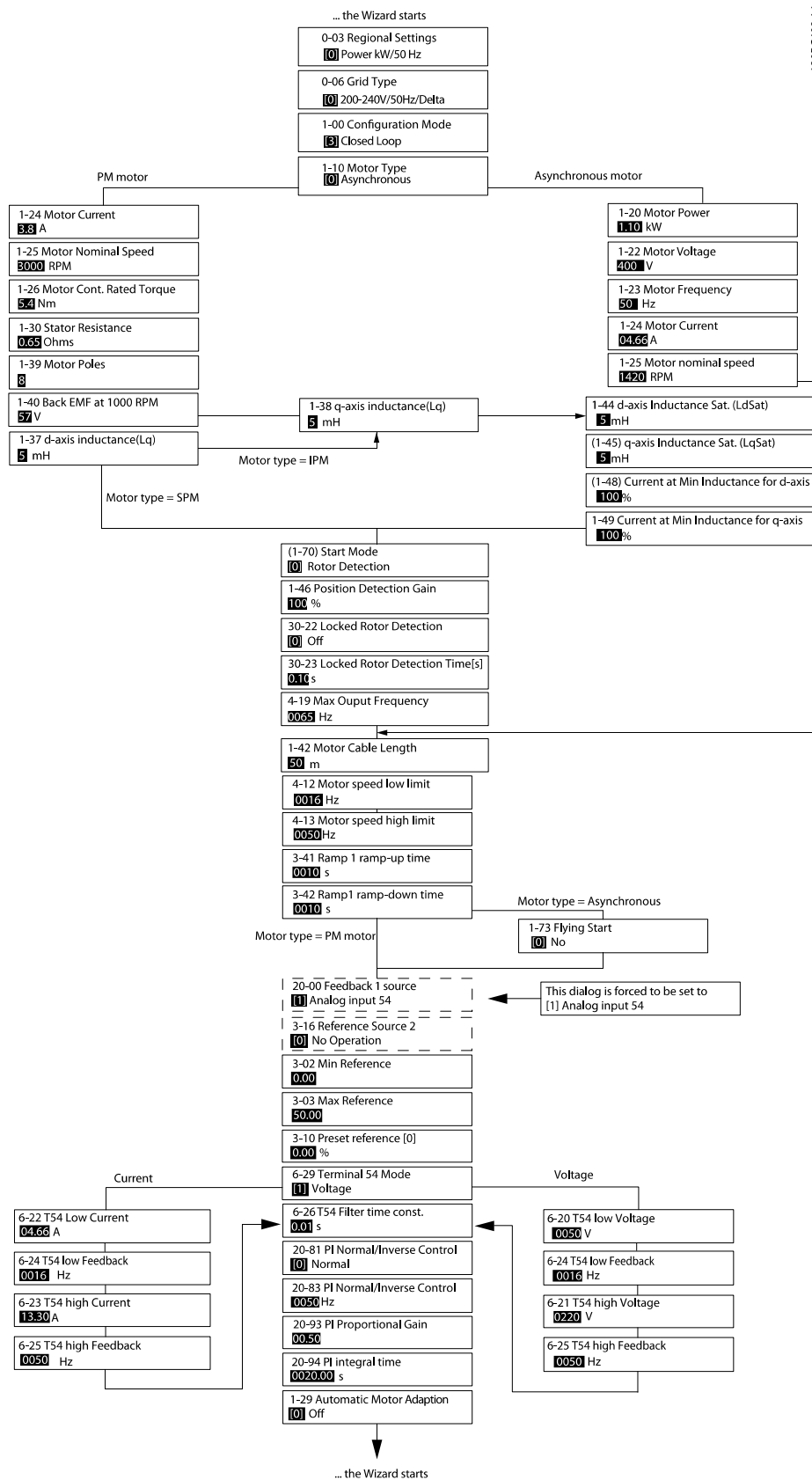

Illustration 4.5 Set-up Wizard for Closed-loop Applications

---

**Programming**

---

Parameter	Range	Default	Usage
<i>Parameter 0-03 Regional Settings</i>	<i>[0] International [1] US</i>	<i>[0] International</i>	–
<i>Parameter 0-06 GridType</i>	<i>[0]–[132] see Table 4.4.</i>	<i>Size selected</i>	Select the operating mode for restart after reconnection of the frequency converter to mains voltage after power-down.
<i>Parameter 1-00 Configuration Mode</i>	<i>[0] Open loop [3] Closed loop</i>	<i>[0] Open loop</i>	Select <i>[3] Closed loop</i> .

**4**

Parameter	Range	Default	Usage
Parameter 1-10 Motor Construction	*[0] Asynchron [1] PM, non-salient SPM [3] PM, salient IPM	[0] Asynchron	<p>Setting the parameter value might change these parameters:</p> <ul style="list-style-type: none"> <li>• Parameter 1-01 Motor Control Principle.</li> <li>• Parameter 1-03 Torque Characteristics.</li> <li>• Parameter 1-08 Motor Control Bandwidth.</li> <li>• Parameter 1-14 Damping Gain.</li> <li>• Parameter 1-15 Low Speed Filter Time Const.</li> <li>• Parameter 1-16 High Speed Filter Time Const.</li> <li>• Parameter 1-17 Voltage filter time const.</li> <li>• Parameter 1-20 Motor Power.</li> <li>• Parameter 1-22 Motor Voltage.</li> <li>• Parameter 1-23 Motor Frequency.</li> <li>• Parameter 1-24 Motor Current.</li> <li>• Parameter 1-25 Motor Nominal Speed.</li> <li>• Parameter 1-26 Motor Cont. Rated Torque.</li> <li>• Parameter 1-30 Stator Resistance (Rs).</li> <li>• Parameter 1-33 Stator Leakage Reactance (X1).</li> <li>• Parameter 1-35 Main Reactance (Xh).</li> <li>• Parameter 1-37 d-axis Inductance (Ld).</li> <li>• Parameter 1-38 q-axis Inductance (Lq).</li> <li>• Parameter 1-39 Motor Poles.</li> <li>• Parameter 1-40 Back EMF at 1000 RPM.</li> <li>• Parameter 1-44 d-axis Inductance Sat. (LdSat).</li> <li>• Parameter 1-45 q-axis Inductance Sat. (LqSat).</li> <li>• Parameter 1-46 Position Detection Gain.</li> <li>• Parameter 1-48 Current at Min Inductance for d-axis.</li> <li>• Parameter 1-49 Current at Min Inductance for q-axis.</li> <li>• Parameter 1-66 Min. Current at Low Speed.</li> <li>• Parameter 1-70 Start Mode.</li> <li>• Parameter 1-72 Start Function.</li> <li>• Parameter 1-73 Flying Start.</li> <li>• Parameter 1-80 Function at Stop.</li> <li>• Parameter 1-82 Min Speed for Function at Stop [Hz].</li> <li>• Parameter 1-90 Motor Thermal Protection.</li> <li>• Parameter 2-00 DC Hold/Motor Preheat Current.</li> <li>• Parameter 2-01 DC Brake Current.</li> <li>• Parameter 2-02 DC Braking Time.</li> <li>• Parameter 2-04 DC Brake Cut In Speed.</li> <li>• Parameter 2-10 Brake Function.</li> <li>• Parameter 4-14 Motor Speed High Limit [Hz].</li> <li>• Parameter 4-19 Max Output Frequency.</li> <li>• Parameter 4-58 Missing Motor Phase Function.</li> <li>• Parameter 14-65 Speed Derate Dead Time Compensation.</li> </ul>

## Programming

4

Parameter	Range	Default	Usage
Parameter 1-20 Motor Power	0.09–110 kW	Size related	Enter the motor power from the nameplate data.
Parameter 1-22 Motor Voltage	50–1000 V	Size related	Enter the motor voltage from the nameplate data.
Parameter 1-23 Motor Frequency	20–400 Hz	Size related	Enter the motor frequency from the nameplate data.
Parameter 1-24 Motor Current	0–10000 A	Size related	Enter the motor current from the nameplate data.
Parameter 1-25 Motor Nominal Speed	50–9999 RPM	Size related	Enter the motor nominal speed from the nameplate data.
Parameter 1-26 Motor Cont. Rated Torque	0.1–1000.0 Nm	Size related	This parameter is available when <i>parameter 1-10 Motor Construction</i> is set to options that enable permanent magnet motor mode. <b>NOTICE</b> Changing this parameter affects the settings of other parameters.
Parameter 1-29 Automatic Motor Adaption (AMA)		Off	Performing an AMA optimizes motor performance.
Parameter 1-30 Stator Resistance (Rs)	0–99,990 Ω	Size related	Set the stator resistance value.
Parameter 1-37 d-axis Inductance (Ld)	0.000–1000.000 mH	Size related	Enter the value of the d-axis inductance. Obtain the value from the permanent magnet motor datasheet.
Parameter 1-38 q-axis Inductance (Lq)	0.000–1000.000 mH	Size related	Enter the value of the q-axis inductance.
Parameter 1-39 Motor Poles	2–100	4	Enter the number of motor poles.
Parameter 1-40 Back EMF at 1000 RPM	10–9000 V	Size related	Line-line RMS back EMF voltage at 1000 RPM.
Parameter 1-42 Motor Cable Length	0–100 m	50 m	Enter the motor cable length.
Parameter 1-44 d-axis Inductance Sat. (LdSat)	0.000–1000.000 mH	Size related	This parameter corresponds to the inductance saturation of Ld. Ideally, this parameter has the same value as <i>parameter 1-37 d-axis Inductance (Ld)</i> . However, if the motor supplier provides an induction curve, enter the induction value, which is 200% of the nominal current.
Parameter 1-45 q-axis Inductance Sat. (LqSat)	0.000–1000.000 mH	Size related	This parameter corresponds to the inductance saturation of Lq. Ideally, this parameter has the same value as <i>parameter 1-38 q-axis Inductance (Lq)</i> . However, if the motor supplier provides an induction curve, enter the induction value, which is 200% of the nominal current.
Parameter 1-46 Position Detection Gain	20–200%	100%	Adjusts the height of the test pulse during position detection at start.
Parameter 1-48 Current at Min Inductance for d-axis	20–200%	100%	Enter the inductance saturation point.
Parameter 1-49 Current at Min Inductance for q-axis	20–200%	100%	This parameter specifies the saturation curve of the d- and q-inductance values. From 20–100% of this parameter, the inductances are linearly approximated due to <i>parameter 1-37 d-axis Inductance (Ld)</i> , <i>parameter 1-38 q-axis Inductance (Lq)</i> , <i>parameter 1-44 d-axis Inductance Sat. (LdSat)</i> , and <i>parameter 1-45 q-axis Inductance Sat. (LqSat)</i> .
Parameter 1-70 Start Mode	[0] Rotor Detection [1] Parking	[0] Rotor Detection	Select the PM motor start mode.
Parameter 1-73 Flying Start	[0] Disabled [1] Enabled	[0] Disabled	Select [1] Enabled to enable the frequency converter to catch a spinning motor in, for example, fan applications. When PM is selected, this parameter is enabled.

Parameter	Range	Default	Usage
Parameter 3-02 Minimum Reference	-4999.000–4999.000	0	The minimum reference is the lowest value obtainable by summing all references.
Parameter 3-03 Maximum Reference	-4999.000–4999.000	50	The maximum reference is the highest value obtainable by summing all references.
Parameter 3-10 Preset Reference	-100–100%	0	Enter the setpoint.
Parameter 3-41 Ramp 1 Ramp Up Time	0.05–3600.0 s	Size related	Ramp-up time from 0 to rated <i>parameter 1-23 Motor Frequency</i> for asynchronous motors. Ramp-up time from 0 to <i>parameter 1-25 Motor Nominal Speed</i> for PM motors.
Parameter 3-42 Ramp 1 Ramp Down Time	0.05–3600.0 s	Size related	Ramp-down time from rated <i>parameter 1-23 Motor Frequency</i> to 0 for asynchronous motors. Ramp-down time from <i>parameter 1-25 Motor Nominal Speed</i> to 0 for PM motors.
Parameter 4-12 Motor Speed Low Limit [Hz]	0.0–400.0 Hz	0.0 Hz	Enter the minimum limit for low speed.
Parameter 4-14 Motor Speed High Limit [Hz]	0.0–400.0 Hz	100 Hz	Enter the maximum limit for high speed.
Parameter 4-19 Max Output Frequency	0.0–400.0 Hz	100 Hz	Enter the maximum output frequency value. If <i>parameter 4-19 Max Output Frequency</i> is set lower than <i>parameter 4-14 Motor Speed High Limit [Hz]</i> , <i>parameter 4-14 Motor Speed High Limit [Hz]</i> is set equal to <i>parameter 4-19 Max Output Frequency</i> automatically.
Parameter 6-20 Terminal 54 Low Voltage	0.00–10.00 V	0.07 V	Enter the voltage that corresponds to the low reference value.
Parameter 6-21 Terminal 54 High Voltage	0.00–10.00 V	10.00 V	Enter the voltage that corresponds to the high reference value.
Parameter 6-22 Terminal 54 Low Current	0.00–20.00 mA	4.00 mA	Enter the current that corresponds to the low reference value.
Parameter 6-23 Terminal 54 High Current	0.00–20.00 mA	20.00 mA	Enter the current that corresponds to the high reference value.
Parameter 6-24 Terminal 54 Low Ref./Feedb. Value	-4999–4999	0	Enter the feedback value that corresponds to the voltage or current set in <i>parameter 6-20 Terminal 54 Low Voltage/parameter 6-22 Terminal 54 Low Current</i> .
Parameter 6-25 Terminal 54 High Ref./Feedb. Value	-4999–4999	50	Enter the feedback value that corresponds to the voltage or current set in <i>parameter 6-21 Terminal 54 High Voltage/parameter 6-23 Terminal 54 High Current</i> .
Parameter 6-26 Terminal 54 Filter Time Constant	0.00–10.00 s	0.01	Enter the filter time constant.
Parameter 6-29 Terminal 54 mode	[0] Current [1] Voltage	[1] Voltage	Select if terminal 54 is used for current or voltage input.
Parameter 20-81 PI Normal/Inverse Control	[0] Normal [1] Inverse	[0] Normal	Select [0] <i>Normal</i> to set the process control to increase the output speed when the process error is positive. Select [1] <i>Inverse</i> to reduce the output speed.
Parameter 20-83 PI Start Speed [Hz]	0–200 Hz	0 Hz	Enter the motor speed to be attained as a start signal for commencement of PI control.
Parameter 20-93 PI Proportional Gain	0.00–10.00	0.01	Enter the process controller proportional gain. Quick control is obtained at high amplification. However, if amplification is too high, the process may become unstable.
Parameter 20-94 PI Integral Time	0.1–999.0 s	999.0 s	Enter the process controller integral time. Obtain quick control through a short integral time, though if the integral time is too short, the process becomes unstable. An excessively long integral time disables the integral action.
Parameter 30-22 Locked Rotor Protection	[0] Off [1] On	[0] Off	–

---

**Programming**

---

Parameter	Range	Default	Usage
Parameter 30-23 Locked Rotor Detection Time [s]	0.05–1.00 s	0.10 s	–

**Table 4.5 Set-up Wizard for Closed-loop Applications**

**Motor set-up**

The motor set-up wizard guides users through the needed motor parameters.

**4**

Parameter	Range	Default	Usage
Parameter 0-03 Regional Settings	[0] International [1] US	0	–
Parameter 0-06 GridType	[0]–[132] see Table 4.4.	Size related	Select the operating mode for restart after reconnection of the frequency converter to mains voltage after power-down.

Parameter	Range	Default	Usage
Parameter 1-10 Motor Construction	*[0] Asynchron [1] PM, non-salient SPM [3] PM, salient IPM	[0] Asynchron	<p>Setting the parameter value might change these parameters:</p> <ul style="list-style-type: none"> <li>• Parameter 1-01 Motor Control Principle.</li> <li>• Parameter 1-03 Torque Characteristics.</li> <li>• Parameter 1-08 Motor Control Bandwidth.</li> <li>• Parameter 1-14 Damping Gain.</li> <li>• Parameter 1-15 Low Speed Filter Time Const.</li> <li>• Parameter 1-16 High Speed Filter Time Const.</li> <li>• Parameter 1-17 Voltage filter time const.</li> <li>• Parameter 1-20 Motor Power.</li> <li>• Parameter 1-22 Motor Voltage.</li> <li>• Parameter 1-23 Motor Frequency.</li> <li>• Parameter 1-24 Motor Current.</li> <li>• Parameter 1-25 Motor Nominal Speed.</li> <li>• Parameter 1-26 Motor Cont. Rated Torque.</li> <li>• Parameter 1-30 Stator Resistance (Rs).</li> <li>• Parameter 1-33 Stator Leakage Reactance (X1).</li> <li>• Parameter 1-35 Main Reactance (Xh).</li> <li>• Parameter 1-37 d-axis Inductance (Ld).</li> <li>• Parameter 1-38 q-axis Inductance (Lq).</li> <li>• Parameter 1-39 Motor Poles.</li> <li>• Parameter 1-40 Back EMF at 1000 RPM.</li> <li>• Parameter 1-44 d-axis Inductance Sat. (LdSat).</li> <li>• Parameter 1-45 q-axis Inductance Sat. (LqSat).</li> <li>• Parameter 1-46 Position Detection Gain.</li> <li>• Parameter 1-48 Current at Min Inductance for d-axis.</li> <li>• Parameter 1-49 Current at Min Inductance for q-axis.</li> <li>• Parameter 1-66 Min. Current at Low Speed.</li> <li>• Parameter 1-70 Start Mode.</li> <li>• Parameter 1-72 Start Function.</li> <li>• Parameter 1-73 Flying Start.</li> <li>• Parameter 1-80 Function at Stop.</li> <li>• Parameter 1-82 Min Speed for Function at Stop [Hz].</li> <li>• Parameter 1-90 Motor Thermal Protection.</li> <li>• Parameter 2-00 DC Hold/Motor Preheat Current.</li> <li>• Parameter 2-01 DC Brake Current.</li> <li>• Parameter 2-02 DC Braking Time.</li> <li>• Parameter 2-04 DC Brake Cut In Speed.</li> <li>• Parameter 2-10 Brake Function.</li> <li>• Parameter 4-14 Motor Speed High Limit [Hz].</li> <li>• Parameter 4-19 Max Output Frequency.</li> <li>• Parameter 4-58 Missing Motor Phase Function.</li> <li>• Parameter 14-65 Speed Derate Dead Time Compensation.</li> </ul>



## Programming

4

Parameter	Range	Default	Usage
Parameter 1-20 Motor Power	0.12–110 kW/0.16–150 hp	Size related	Enter the motor power from the nameplate data.
Parameter 1-22 Motor Voltage	50–1000 V	Size related	Enter the motor voltage from the nameplate data.
Parameter 1-23 Motor Frequency	20–400 Hz	Size related	Enter the motor frequency from the nameplate data.
Parameter 1-24 Motor Current	0.01–10000.00 A	Size related	Enter the motor current from the nameplate data.
Parameter 1-25 Motor Nominal Speed	50–9999 RPM	Size related	Enter the motor nominal speed from the nameplate data.
Parameter 1-26 Motor Cont. Rated Torque	0.1–1000.0 Nm	Size related	This parameter is available when <i>parameter 1-10 Motor Construction</i> is set to options that enable permanent magnet motor mode. <b>NOTICE</b> Changing this parameter affects the settings of other parameters.
Parameter 1-30 Stator Resistance (Rs)	0–99.990 Ω	Size related	Set the stator resistance value.
Parameter 1-37 d-axis Inductance (Ld)	0.000–1000.000 mH	Size related	Enter the value of the d-axis inductance. Obtain the value from the permanent magnet motor datasheet.
Parameter 1-38 q-axis Inductance (Lq)	0.000–1000.000 mH	Size related	Enter the value of the q-axis inductance.
Parameter 1-39 Motor Poles	2–100	4	Enter the number of motor poles.
Parameter 1-40 Back EMF at 1000 RPM	10–9000 V	Size related	Line-line RMS back EMF voltage at 1000 RPM.
Parameter 1-42 Motor Cable Length	0–100 m	50 m	Enter the motor cable length.
Parameter 1-44 d-axis Inductance Sat. (LdSat)	0.000–1000.000 mH	Size related	This parameter corresponds to the inductance saturation of Ld. Ideally, this parameter has the same value as <i>parameter 1-37 d-axis Inductance (Ld)</i> . However, if the motor supplier provides an induction curve, enter the induction value, which is 200% of the nominal current.
Parameter 1-45 q-axis Inductance Sat. (LqSat)	0.000–1000.000 mH	Size related	This parameter corresponds to the inductance saturation of Lq. Ideally, this parameter has the same value as <i>parameter 1-38 q-axis Inductance (Lq)</i> . However, if the motor supplier provides an induction curve, enter the induction value, which is 200% of the nominal current.
Parameter 1-46 Position Detection Gain	20–200%	100%	Adjusts the height of the test pulse during position detection at start.
Parameter 1-48 Current at Min Inductance for d-axis	20–200%	100%	Enter the inductance saturation point.
Parameter 1-49 Current at Min Inductance for q-axis	20–200%	100%	This parameter specifies the saturation curve of the d- and q-inductance values. From 20–100% of this parameter, the inductances are linearly approximated due to <i>parameter 1-37 d-axis Inductance (Ld)</i> , <i>parameter 1-38 q-axis Inductance (Lq)</i> , <i>parameter 1-44 d-axis Inductance Sat. (LdSat)</i> , and <i>parameter 1-45 q-axis Inductance Sat. (LqSat)</i> .
Parameter 1-70 Start Mode	[0] Rotor Detection [1] Parking	[0] Rotor Detection	Select the PM motor start mode.
Parameter 1-73 Flying Start	[0] Disabled [1] Enabled	[0] Disabled	Select [1] Enabled to enable the frequency converter to catch a spinning motor.
Parameter 3-41 Ramp 1 Ramp Up Time	0.05–3600.0 s	Size related	Ramp-up time from 0 to rated <i>parameter 1-23 Motor Frequency</i> .
Parameter 3-42 Ramp 1 Ramp Down Time	0.05–3600.0 s	Size related	Ramp-down time from rated <i>parameter 1-23 Motor Frequency</i> to 0.

Parameter	Range	Default	Usage
Parameter 4-12 Motor Speed Low Limit [Hz]	0.0–400.0 Hz	0.0 Hz	Enter the minimum limit for low speed.
Parameter 4-14 Motor Speed High Limit [Hz]	0.0–400.0 Hz	100.0 Hz	Enter the maximum limit for high speed.
Parameter 4-19 Max Output Frequency	0.0–400.0 Hz	100.0 Hz	Enter the maximum output frequency value. If parameter 4-19 Max Output Frequency is set lower than parameter 4-14 Motor Speed High Limit [Hz], parameter 4-14 Motor Speed High Limit [Hz] is set equal to parameter 4-19 Max Output Frequency automatically.
Parameter 30-22 Locked Rotor Protection	[0] Off [1] On	[0] Off	–
Parameter 30-23 Locked Rotor Detection Time [s]	0.05–1.00 s	0.10 s	–

**Table 4.6 Motor Set-up Wizard Settings**
**Changes made**

The changes made function lists all parameters changed from default settings.

- The list shows only parameters that have been changed in the current edit set-up.
- Parameters that have been reset to default values are not listed.
- The message *Empty* indicates that no parameters have been changed.

**Changing parameter settings**

1. To enter the Quick Menu, press the [Menu] key until the indicator in the display is placed above Quick Menu.
2. Press [▲] [▼] to select the wizard, closed-loop set-up, motor set-up, or changes made.
3. Press [OK].
4. Press [▲] [▼] to browse through the parameters in the Quick Menu.
5. Press [OK] to select a parameter.
6. Press [▲] [▼] to change the value of a parameter setting.
7. Press [OK] to accept the change.
8. Press either [Back] twice to enter Status, or press [Menu] once to enter the Main Menu.

**The main menu accesses all parameters**

1. Press the [Menu] key until the indicator in the display is placed above Main Menu.
2. Press [▲] [▼] to browse through the parameter groups.
3. Press [OK] to select a parameter group.
4. Press [▲] [▼] to browse through the parameters in the specific group.
5. Press [OK] to select the parameter.
6. Press [▲] [▼] to set/change the parameter value.
7. Press [OK] to accept the change.

**4.3 Parameter List**

# Programming

4

<b>0-0*</b>	<b>Operation / Display</b>	1-43	Motor Cable Length Feet	3-8*	Other Ramps	6-15	Terminal 53 High Ref./Feedb. Value	8-8*	FC Port Diagnostics
0-0*	Basic Settings	1-44	d-axis Inductance Sat. (LdSat)	3-80	Jog Ramp Time	6-16	Terminal 53 Filter Time Constant	8-80	Bus Message Count
0-01	Language	1-45	q-axis Inductance Sat. (LqSat)	3-81	Quick-Stop Ramp Time	6-19	Terminal 53 mode	8-81	Bus Error Count
0-03	Regional Settings	1-46	Position Detection Gain	<b>4-1*</b>	<b>Limits / Warnings</b>	<b>6-2*</b>	<b>Analog Input 54</b>	8-82	Slave Messages Rcvd
0-04	Operating State at Power-up	1-48	Current at Min Inductance for d-axis	4-1*	Motor Limits	6-20	Terminal 54 Low Voltage	8-83	Slave Messages Sent
0-06	GridType	1-49	Current at Min Inductance for q-axis	4-10	Motor Speed Direction	6-21	Terminal 54 High Voltage	8-84	Slave Timeout Errors
0-07	Auto DC Braking	1-5*	<b>Load Indep. Setting</b>	4-12	Motor Speed Low Limit [Hz]	6-22	Terminal 54 Low Current	8-85	Slave Timeout Errors
0-10	Active Set-up	1-50	Motor Magnetisation at Zero Speed	4-14	Motor Speed High Limit [Hz]	6-23	Terminal 54 High Current	8-88	Reset FC port Diagnostics
0-11	Programming Set-up	1-52	Min Speed Normal Magnetising [Hz]	4-18	Current Limit	6-24	Terminal 54 High Ref./Feedb. Value	8-9*	Bus Feedback
0-12	Link Setups	1-55	Uf Characteristic - U	4-19	Max Output Frequency	6-25	Terminal 54 High Ref./Feedb. Value	8-94	Bus Feedback 1
0-3*	<b>LCP Custom Readout</b>	1-56	Uf Characteristic - F	4-4*	Adj. Warnings 2	6-26	Terminal 54 Filter Time Constant	8-95	Bus Feedback 2
0-30	Custom Readout Unit	1-6*	<b>Load Depen. Setting</b>	4-40	Warning Freq. Low	6-29	Terminal 54 mode	<b>13-3**</b>	<b>Smart Logic</b>
0-31	Custom Readout Min Value	1-62	Slip Compensation	4-41	Warning Freq. High	6-7*	<b>Analog/Digital Output 45</b>	<b>13-0*</b>	<b>SLC Settings</b>
0-32	Custom Readout Max Value	1-63	Slip Compensation Time Constant	4-5*	Adj. Warnings	6-70	Terminal 45 Mode	13-00	SL Controller Mode
0-37	Display Text 1	1-64	Resonance Dampening	4-50	Warning Current Low	6-71	Terminal 45 Analog Output	13-01	Start Event
0-38	Display Text 2	1-65	Resonance Dampening Time Constant	4-51	Warning Current High	6-72	Terminal 45 Digital Output	13-02	Stop Event
0-39	Display Text 3	1-66	Min. Current at Low Speed	4-54	Warning Reference Low	6-73	Terminal 45 Output Min Scale	13-03	Reset SLC
0-4*	<b>LCP Keypad</b>	1-7*	<b>Start Adjustments</b>	4-55	Warning Reference High	6-74	Terminal 45 Output Max Scale	<b>13-1*</b>	<b>Comparators</b>
0-40	[Hand on] Key on LCP	1-70	Start Mode	4-56	Warning Feedback Low	6-76	Terminal 45 Output Bus Control	13-10	Comparator Operator
0-42	[Auto on] Key on LCP	1-71	Start Delay	4-57	Warning Feedback High	6-9*	<b>Analog/Digital Output 42</b>	13-11	Comparator Operator
0-44	[Off/Reset] Key on LCP	1-72	Start Function	4-58	Missing Motor Phase Function	6-90	Terminal 42 Mode	13-12	Comparator Value
0-5*	<b>Copy/Save</b>	1-73	Flying Start	4-6*	Speed Bypass	6-91	Terminal 42 Analog Output	<b>13-2*</b>	<b>Timers</b>
0-50	LCP Copy	1-8*	<b>Stop Adjustments</b>	4-61	Bypass Speed From [Hz]	6-92	Terminal 42 Digital Output	13-20	SL Controller Timer
0-51	Set-up Copy	1-80	Function at Stop	4-63	Bypass Speed To [Hz]	6-93	Terminal 42 Output Min Scale	<b>13-4*</b>	<b>Logic Rules</b>
0-6*	<b>Password</b>	1-82	Min Speed for Function at Stop [Hz]	4-64	Semi-Auto Bypass Set-up	6-96	Terminal 42 Output Max Scale	13-40	Logic Rule Boolean 1
0-60	Main Menu Password	1-9*	AC Brake Gain	<b>5-*</b>	<b>Digital In/Out</b>	6-94	Terminal 42 Output Bus Control	13-41	Logic Rule Operator 1
0-61	Access to Main Menu w/o Password	1-90	Motor Temperature	5-0*	Digital I/O Mode	6-98	Drive Type	13-42	Logic Rule Boolean 2
<b>1-0*</b>	<b>Load and Motor</b>	1-90	Motor Thermal Protection	5-00	Digital Input Mode	<b>8-*</b>	<b>Comm. and Options</b>	13-43	Logic Rule Operator 2
1-0*	General Settings	1-93	Thermistor Source	5-03	Digital Input 29 Mode	8-0*	General Settings	13-44	Logic Rule Boolean 3
1-00	Configuration Mode	<b>2-3**</b>	<b>Brakes</b>	5-1*	Digital Inputs	8-01	Control Site	<b>13-5*</b>	<b>States</b>
1-01	Motor Control Principle	2-0*	DC-Brake	5-10	Terminal 18 Digital Input	8-02	Control Source	13-51	SL Controller Event
1-03	Torque Characteristics	2-00	DC Hold/Motor Preheat Current	5-11	Terminal 19 Digital Input	8-03	Control Timeout Time	13-52	SL Controller Action
1-06	Clockwise Direction	2-01	DC Brake Current	5-12	Terminal 27 Digital Input	8-04	Control Timeout Function	<b>14-3**</b>	<b>Special Functions</b>
1-08	Motor Control Bandwidth	2-02	DC Braking Time	5-13	Terminal 29 Digital Input	<b>8-3*</b>	<b>FC Port Settings</b>	<b>14-0*</b>	<b>Inverter Switching</b>
1-1*	<b>Motor Selection</b>	2-04	DC Brake Cut In Speed	5-3*	<b>Digital Outputs</b>	8-30	Protocol	14-01	Switching Frequency
1-10	Motor Construction	2-06	Parking Current	5-34	On Delay, Digital Output	8-31	Address	14-03	Overmodulation
1-14	Damping Gain	2-07	Parking Time	5-35	Off Delay, Digital Output	8-32	Baud Rate	14-07	Dead Time Compensation Level
1-15	Low Speed Filter Time Const.	<b>2-1*</b>	<b>Brake Energy Funct.</b>	5-4*	Relays	8-33	Parity / Stop Bits	14-08	Damping Gain Factor
1-16	High Speed Filter Time Const.	2-10	Brake Function	5-40	Function Relay	8-35	Minimum Response Delay	14-09	Dead Time Bias Current Level
1-17	Voltage filter time const.	2-16	AC Brake, Max current	5-41	On Delay, Relay	8-36	Maximum Response Delay	<b>14-1*</b>	<b>Mains Failure</b>
<b>1-2*</b>	<b>Motor Data</b>	2-17	Over-voltage Control	5-42	Off Delay, Relay	8-37	Maximum Inter-char delay	14-10	Mains Failure
1-20	Motor Power	2-19	Over-voltage Gain	5-5*	Pulse Input	8-4*	<b>FC MC protocol set</b>	14-11	Mains Fault Voltage Level
1-22	Motor Voltage	<b>3-0*</b>	<b>Reference Limits</b>	5-50	Term. 29 Low Frequency	8-42	PCD Write Configuration	14-12	Response to Mains Imbalance
1-23	Motor Frequency	3-02	Minimum Reference	5-51	Term. 29 High Frequency	8-43	PCD Read Configuration	14-15	Kin. Back-up Trip Recovery Level
1-24	Motor Current	3-03	Maximum Reference	5-52	Term. 29 Low Ref./Feedb. Value	<b>8-5*</b>	<b>Digital/Bus</b>	<b>14-2*</b>	<b>Reset Functions</b>
1-25	Motor Nominal Speed	3-1*	References	5-53	Term. 29 High Ref./Feedb. Value	8-50	Coasting Select	14-20	Reset Mode
1-26	Motor Cont. Rated Torque	3-10	Preset Reference	5-90	<b>Bus Controlled</b>	8-51	Quick Stop Select	14-21	Automatic Restart Time
1-29	Automatic Motor Adaptation (AMA)	3-11	Jog Speed [Hz]	<b>6-*</b>	<b>Analog In/Out</b>	8-52	DC Brake Select	14-22	Operation Mode
1-30	Stator Resistance (Rs)	3-14	Preset Relative Reference	6-00	Live Zero Timeout Time	8-54	Reversing Select	14-23	Typecode Setting
1-33	Stator Leakage Reactance (X1)	3-15	Reference 1 Source	6-01	Live Zero Timeout Function	8-55	Set-up Select	14-27	Action At Inverter Fault
1-35	Main Reactance (Xh)	3-16	Reference 2 Source	6-02	Fire Mode Live Zero Timeout Function	8-56	Preset Reference Select	14-28	Production Settings
1-37	d-axis Inductance (Ld)	3-17	Reference 3 Source	6-1*	<b>Analog Input 53</b>	<b>8-7*</b>	<b>BACnet</b>	<b>14-3*</b>	<b>Current Limit Ctrl.</b>
1-38	q-axis Inductance (Lq)	3-41	Ramp 1	6-10	Terminal 53 Low Voltage	8-70	BACnet Device Instance	14-30	Current Lim Ctrl, Proportional Gain
1-39	Motor Poles	3-42	Ramp 1 Ramp Up Time	6-11	Terminal 53 High Voltage	8-72	MS/TP Max Masters	14-31	Current Lim Ctrl, Integration Time
<b>1-4*</b>	<b>Adv. Motor Data II</b>	3-45	Ramp 2	6-12	Terminal 53 Low Current	8-73	MS/TP Max Info Frames	14-32	Current Lim Ctrl, Filter Time
1-40	Back EMF at 1000 RPM	3-51	Ramp 2 Ramp Up Time	6-13	Terminal 53 High Current	8-74	"I am" Service	<b>14-4*</b>	<b>Energy Optimising</b>
1-42	Motor Cable Length	3-52	Ramp 2 Ramp Down Time	6-14	Terminal 53 Low Ref./Feedb. Value	8-75	Initialisation Password	14-40	VT Level
						8-79	Protocol Firmware version	14-41	AE0 Minimum Magnetisation

14-44	d-axis current optimization for iPM	16-11	Power [hp]	20-2*	Feedback/Setpoint	24-07	Fire Mode Feedback Source
14-5*	Environment	16-12	Motor Voltage	20-20	Feedback Function	24-09	FM Alarm Handling
14-50	RFI Filter	16-13	Frequency	20-21	Setpoint 1	24-1*	Drive Bypass
14-51	DC-Link Voltage Compensation	16-14	Motor current	20-6*	Sensorless	24-10	Drive Bypass Function
14-52	Fan Control	16-15	Frequency [%]	20-60	Sensorless Unit	24-11	Drive Bypass Delay Time
14-53	Fan Monitor	16-16	Torque [Nm]	20-69	Sensorless Information	30-**	Special Features
14-55	Output Filter	16-17	Speed [RPM]	20-8*	PI Basic Settings	30-2*	Adv. Start Adjust
14-6*	Auto Derate	16-18	Motor Thermal	20-81	PI Normal/ Inverse Control	30-22	Locked Rotor Protection
14-61	Function at Inverter Overload	16-22	Torque [%]	20-83	PI Start Speed [Hz]	30-23	Locked Rotor Detection Time [s]
14-63	Min Switch Frequency	16-26	Power Filtered [kW]	20-84	On Reference Bandwidth	30-5*	Unit Configuration
14-64	Dead Time Compensation Zero Current Level	16-27	Power Filtered [hp]	20-9*	PI Controller	30-58	LockPassword
14-65	Speed Derate Dead Time Compensation	16-3*	Drive Status	20-91	PI Anti Windup		
		16-30	DC Link Voltage	20-93	PI Proportional Gain		
		16-34	Heatsink Temp.	20-94	PI Integral Time		
14-9*	Fault Settings	16-35	Inverter Thermal	20-97	PI Feed Forward Factor		
14-90	Fault Level	16-36	Inv. Nom. Current	22-**	Appli. Functions		
15-**	Drive Information	16-37	Inv. Max. Current	22-0*	Miscellaneous		
15-0*	Operating Data	16-38	SL Controller State	22-01	Power Filter Time		
15-00	Operating hours	16-5*	Ref. & Feeds	22-02	Sleepmode CL Control Mode		
15-01	Running Hours	16-50	External Reference	22-2*	No-Flow Detection		
15-02	kWh Counter	16-52	Feedback[Unit]	22-23	No-Flow Function		
15-03	Power Up's	16-54	Feedback 1 [Unit]	22-24	No-Flow Delay		
15-04	Over Temp's	16-55	Feedback 2 [Unit]	22-3*	No-Flow Power Tuning		
15-05	Over Volt's	16-6*	Inputs & Outputs	22-30	No-Flow Power		
15-06	Reset kWh Counter	16-60	Digital Input	22-31	Power Correction Factor		
15-07	Reset Running Hours Counter	16-61	Terminal 29 [Hz]	22-33	Low Speed [Hz]		
15-3*	Alarm Log	16-62	Analog input 53	22-34	Low Speed Power [kW]		
15-30	Alarm Log: Error Code	16-63	Terminal 54 Setting	22-37	High Speed [Hz]		
15-31	InternalFaultReason	16-64	Analog input 54	22-38	High Speed Power [kW]		
15-4*	Drive Identification	16-65	Analog output 42 [mA]	22-4*	Sleep Mode		
15-40	FC Type	16-66	Digital Output	22-40	Minimum Run Time		
15-41	Power Section	16-67	Pulse input 29 [Hz]	22-41	Minimum Sleep Time		
15-42	Voltage	16-71	Relay output	22-43	Wake-Up Speed [Hz]		
15-43	Software Version	16-72	Counter A	22-44	Wake-Up Ref./FB Diff		
15-44	Ordered TypeCode	16-73	Counter B	22-45	Setpoint Boost		
15-45	Actual Typecode String	16-79	Analog output 45 [mA]	22-46	Maximum Boost Time		
15-46	Drive Ordering No	16-8*	Fieldbus & FC Port	22-47	Sleep Speed [Hz]		
15-48	LCP Id No	16-86	FC Port REF 1	22-48	Sleep Delay Time		
15-49	SW ID Control Card	16-9*	Diagnosis Readouts	22-49	Wake-Up Delay Time		
15-50	SW ID Power Card	16-90	Alarm Word	22-6*	Broken Belt Detection		
15-51	Drive Serial Number	16-91	Alarm Word 2	22-60	Broken Belt Function		
15-52	OEM Information	16-92	Warning Word	22-61	Broken Belt Torque		
15-53	Power Card Serial Number	16-93	Warning Word 2	22-62	Broken Belt Delay		
15-57	File Version	16-94	Ext. Status Word	22-8*	Flow Compensation		
15-59	Filename	16-95	Ext. Status Word 2	22-80	Flow Compensation		
15-9*	Parameter Info	16-97	Alarm Word 3	22-81	Square-linear Curve Approximation		
15-92	Defined Parameters	16-98	Warning Word 3	22-82	Work Point Calculation		
15-97	Application Type	18-**	Info & Readouts	22-84	Speed at No-Flow [Hz]		
15-98	Drive Identification	18-1*	Fire Mode Log	22-86	Speed at Design Point [Hz]		
16-**	Data Readouts	18-10	FireMode Log:Event	22-87	Pressure at No-Flow Speed		
16-0*	General Status	18-5*	Ref. & Feeds	22-88	Pressure at Rated Speed		
16-00	Control Word	18-50	Sensorless Readout [unit]	22-89	Flow at Design Point		
16-01	Reference [Unit]	20-0*	Drive Closed Loop	22-90	Flow at Rated Speed		
16-02	Reference [%]	20-0*	Feedback	24-**	Appli. Functions 2		
16-03	Status Word	20-00	Feedback 1 Source	24-0*	Fire Mode		
16-05	Main Actual Value [%]	20-01	Feedback 1 Conversion	24-00	FM Function		
16-09	Custom Readout	20-03	Feedback 2 Source	24-01	Fire Mode Configuration		
16-1*	Motor Status	20-04	Feedback 2 Conversion	24-05	FM Preset Reference		
16-10	Power [kW]	20-12	Reference/Feedback Unit	24-06	Fire Mode Reference Source		

## 5 Warnings and Alarms

5

Fault number	Alarm/warning bit number	Fault text	Warning	Alarm	Trip locked	Cause of problem
2	16	Live zero error	X	X	-	The signal on terminal 53 or 54 is less than 50% of the value set in <i>parameter 6-10 Terminal 53 Low Voltage</i> , <i>parameter 6-12 Terminal 53 Low Current</i> , <i>parameter 6-20 Terminal 54 Low Voltage</i> , or <i>parameter 6-22 Terminal 54 Low Current</i> . See also <i>parameter group 6-0* Analog I/O Mode</i> .
4	14	Mains ph. loss	X	X	X	Missing phase on the supply side or too high voltage imbalance. Check the supply voltage. See <i>parameter 14-12 Response to Mains Imbalance</i> .
7	11	DC over volt	X	X	-	DC-link voltage exceeds the limit.
8	10	DC under volt	X	X	-	DC-link voltage drops below voltage warning low-limit.
9	9	Inverter overload	X	X	-	More than 100% load for a long time.
10	8	Motor ETR over	X	X	-	The motor is too hot due to more than 100% load for a long time. See <i>parameter 1-90 Motor Thermal Protection</i> .
11	7	Motor th over	X	X	-	Thermistor or thermistor connection is disconnected. See <i>parameter 1-90 Motor Thermal Protection</i> .
13	5	Over Current	X	X	X	Inverter peak current limit is exceeded.
14	2	Earth Fault	-	X	X	Discharge from output phases to ground.
16	12	Short Circuit	-	X	X	Short circuit in motor or on motor terminals.
17	4	Ctrl. word TO	X	X	-	No communication to frequency converter. See <i>parameter group 8-0* General Settings</i> .
24	50	Fan Fault	X	X	-	The heat sink cooling fan is not working (only on 400 V, 30–90 kW units).
30	19	U phase loss	-	X	X	Motor phase U is missing. Check the phase. See <i>parameter 4-58 Missing Motor Phase Function</i> .
31	20	V phase loss	-	X	X	Motor phase V is missing. Check the phase. See <i>parameter 4-58 Missing Motor Phase Function</i> .
32	21	W phase loss	-	X	X	Motor phase W is missing. Check the phase. See <i>parameter 4-58 Missing Motor Phase Function</i> .
38	17	Internal fault	-	X	X	Contact the local Trane supplier.
44	28	Earth Fault	-	X	X	Discharge from output phases to ground, using the value of <i>parameter 15-31 InternalFaultReason</i> if possible.
46	33	Control Voltage Fault	-	X	X	Control voltage is low. Contact the local Trane supplier.
47	23	24 V supply low	X	X	X	24 V DC supply may be overloaded.
50		AMA calibration failed	-	X	-	Contact the local Trane supplier.
51	15	AMA Unom,Inom	-	X	-	The setting of motor voltage, motor current, and motor power is wrong. Check the settings.
52	-	AMA low Inom	-	X	-	The motor current is too low. Check the settings.
53	-	AMA big motor	-	X	-	The motor is too big to perform AMA.
54	-	AMA small mot	-	X	-	The motor is too small to perform AMA.
55	-	AMA par. range	-	X	-	The parameter values found from the motor are outside the acceptable range.
56	-	AMA user interrupt	-	X	-	The AMA has been interrupted by the user.

Fault number	Alarm/warning bit number	Fault text	Warning	Alarm	Trip locked	Cause of problem
57	-	AMA timeout	-	X	-	Try to start the AMA again a number of times, until the AMA is carried out. <b>NOTICE</b> Repeated runs may heat the motor to a level where the resistance $R_s$ and $R_r$ are increased. In most cases, however, this is not critical.
58	-	AMA internal	X	X	-	Contact the local Trane supplier.
59	25	Current limit	X	-	-	The current is higher than the value in <i>parameter 4-18 Current Limit</i> .
60	44	External Interlock	-	X	-	External interlock has been activated. To resume normal operation, apply 24 V DC to the terminal programmed for external interlock and reset the frequency converter (via serial communication, digital I/O, or by pressing the [Reset] key on the LCP).
66	26	Heat sink Temperature Low	X	-	-	This warning is based on the temperature sensor in the IGBT module (on 400 V, 30–90 kW (40–125 hp) and 600 V units).
69	1	Pwr. Card Temp	X	X	X	The temperature sensor on the power card exceeds the upper or lower limits.
70	36	Illegal FC configuration	-	X	X	The control card and power card are not matched.
79	-	Illegal power section configuration	X	X	-	Internal fault. Contact the local Trane supplier.
80	29	Drive initialised	-	X	-	All parameter settings are initialized to default settings.
87	47	Auto DC Braking	X	-	-	The frequency converter is auto DC braking.
95	40	Broken Belt	X	X	-	Torque is below the torque level set for no load, indicating a broken belt. See <i>parameter group 22-6* Broken Belt Detection</i> .
126	-	Motor Rotating	-	X	-	High back EMF voltage. Stop the rotor of the PM motor.
200	-	Fire Mode	X	-	-	Fire mode has been activated.
202	-	Fire Mode Limits Exceeded	X	-	-	Fire mode has suppressed 1 or more warranty voiding alarms.
250	-	New sparepart	-	X	X	The power or switch mode power supply has been exchanged (on 400 V, 30–90 kW (40–125 hp) and 600 V units). Contact the local Trane supplier.
251	-	New Typecode	-	X	X	The frequency converter has a new type code (on 400 V, 30–90 kW (40–125 hp) and 600 V units). Contact the local Trane supplier.

**Table 5.1 Warnings and Alarms**

## 6 Specifications

### 6.1 Mains Supply

#### 6.1.1 3x200–240 V AC

Frequency converter	TR150							
	PK25	PK37	PK75	P1K5	P2K2	P3K7	P5K5	P7K5
Typical shaft output [kW]	0.25	0.37	0.75	1.5	2.2	3.7	5.5	7.5
Typical shaft output [hp]	0.33	0.5	1.0	2.0	3.0	5.0	7.5	10.0
Protection rating IP20	H1	H1	H1	H1	H2	H3	H4	H4
Maximum cable size in terminals (mains, motor) [mm <sup>2</sup> (AWG)]	4 (10)	4 (10)	4 (10)	4 (10)	4 (10)	4 (10)	16 (6)	16 (6)
<b>Output current</b>								
<b>40 °C (104 °F) ambient temperature</b>								
Continuous (3x200–240 V) [A]	1.5	2.2	4.2	6.8	9.6	15.2	22.0	28.0
Intermittent (3x200–240 V) [A]	1.7	2.4	4.6	7.5	10.6	16.7	24.2	30.8
<b>Maximum input current</b>								
Continuous 3x200–240 V) [A]	1.1	1.6	2.8	5.6	8.6/ 7.2	14.1/ 12.0	21.0/ 18.0	28.3/ 24.0
Intermittent (3x200–240 V) [A]	1.2	1.8	3.1	6.2	9.5/ 7.9	15.5/ 13.2	23.1/ 19.8	31.1/ 26.4
Maximum mains fuses	See chapter 3.2.3 Fuses and Circuit Breakers.							
Estimated power loss [W], Best case/typical <sup>1)</sup>	12/ 14	15/ 18	21/ 26	48/ 60	80/ 102	97/ 120	182/ 204	229/ 268
Weight enclosure protection rating IP20 [kg (lb)]	2.0 (4.4)	2.0 (4.4)	2.0 (4.4)	2.1 (4.6)	3.4 (7.5)	4.5 (9.9)	7.9 (17.4)	7.9 (17.4)
Efficiency [%], best case/ typical <sup>2)</sup>	97.0/ 96.5	97.3/ 96.8	98.0/ 97.6	97.6/ 97.0	97.1/ 96.3	97.9/ 97.4	97.3/ 97.0	98.5/ 97.1
<b>Output current</b>								
<b>50 °C (122 °F) ambient temperature</b>								
Continuous (3x200–240 V) [A]	1.5	1.9	3.5	6.8	9.6	13.0	19.8	23.0
Intermittent (3x200–240 V) [A]	1.7	2.1	3.9	7.5	10.6	14.3	21.8	25.3

**Table 6.1 3x200–240 V AC, 0.25–7.5 kW (0.33–10 hp)**

1) Applies for dimensioning of frequency converter cooling. If the switching frequency is higher than the default setting, the power losses may increase. Keypad and typical control card power consumptions are included.

2) Efficiency measured at nominal current. For energy efficiency class, see chapter 6.4.10 Ambient Conditions.

Frequency converter	TR150							TR170
	P11K	P15K	P18K	P22K	P30K	P37K	P45K	P1K5
Typical shaft output [kW]	11.0	15.0	18.5	22.0	30.0	37.0	45.0	1.5
Typical shaft output [hp]	15.0	20.0	25.0	30.0	40.0	50.0	60.0	2.0
Protection rating IP20	H5	H6	H6	H7	H7	H8	H8	H2
Maximum cable size in terminals (mains, motor) [mm <sup>2</sup> (AWG)]	16 (6)	35 (2)	35 (2)	50 (1)	50 (1)	95 (0)	120 (4/0)	4 (10)
<b>Output current</b>								
<b>40 °C (104 °F) ambient temperature</b>								
Continuous (3x200–240 V) [A]	42.0	59.4	74.8	88.0	115.0	143.0	170.0	6.8
Intermittent (3x200–240 V) [A]	46.2	65.3	82.3	96.8	126.5	157.3	187.0	7.5
<b>Maximum input current</b>								
Continuous 3x200–240 V) [A]	41.0/ 38.2	52.7	65.0	76.0	103.7	127.9	153.0	5.6
Intermittent (3x200–240 V) [A]	45.1/ 42.0	58.0	71.5	83.7	114.1	140.7	168.3	6.2
Maximum mains fuses	See chapter 3.2.3 Fuses and Circuit Breakers							
Estimated power loss [W], Best case/ typical <sup>1)</sup>	369/ 386	512	697	879	1149	1390	1500	48/ 60
Weight enclosure protection rating IP20 [kg (lb)]	9.5 (20.9)	24.5 (54)	24.5 (54)	36.0 (79.4)	36.0 (79.4)	51.0 (112.4)	51.0 (112.4)	3.4 (7.5)
Efficiency [%], best case/ typical <sup>2)</sup>	97.2/ 97.1	97.0	97.1	96.8	97.1	97.1	97.3	97.6 97.0
<b>Output current</b>								
<b>50 °C (122 °F) ambient temperature</b>								<b>70 °C (158 °F)</b>
Continuous (3x200–240 V) [A]	33.0	41.6	52.4	61.6	80.5	100.1	119	6.8
Intermittent (3x200–240 V) [A]	36.3	45.8	57.6	67.8	88.6	110.1	130.9	7.5

**Table 6.2 3x200–240 V AC, 11–45 kW (15–60 hp)**

1) Applies for dimensioning of frequency converter cooling. If the switching frequency is higher than the default setting, the power losses may increase. Keypad and typical control card power consumptions are included.

2) Efficiency measured at nominal current. For energy efficiency class, see chapter 6.4.10 Ambient Conditions.



## Specifications

### 6.1.2 3x380–480 V AC

Frequency converter	TR150										TR170
	PK37	PK75	P1K5	P2K2	P3K0	P4K0	P5K5	P7K5	P11K	P15K	P1K5
Typical shaft output [kW]	0.37	0.75	1.5	2.2	3.0	4.0	5.5	7.5	11.0	15.0	1.5
Typical shaft output [hp]	0.5	1.0	2.0	3.0	4.0	5.0	7.5	10.0	15.0	20.0	2.0
Protection rating IP20	H1	H1	H1	H2	H2	H2	H3	H3	H4	H4	H2
Maximum cable size in terminals (mains, motor) [mm <sup>2</sup> (AWG)]	4 (10)	4 (10)	4 (10)	4 (10)	4 (10)	4 (10)	4 (10)	4 (10)	16 (6)	16 (6)	4 (10)
<b>Output current - 40 °C (104 °F) ambient temperature</b>											
Continuous (3x380–440 V)[A]	1.2	2.2	3.7	5.3	7.2	9.0	12.0	15.5	23.0	31.0	3.7
Intermittent (3x380–440 V) [A]	1.3	2.4	4.1	5.8	7.9	9.9	13.2	17.1	25.3	34.0	4.1
Continuous (3x441–480 V) [A]	1.1	2.1	3.4	4.8	6.3	8.2	11.0	14.0	21.0	27.0	3.4
Intermittent (3x441–480 V) [A]	1.2	2.3	3.7	5.3	6.9	9.0	12.1	15.4	23.1	29.7	3.7
<b>Maximum input current</b>											
Continuous (3x380–440 V) [A]	1.2	2.1	3.5	4.7	6.3	8.3	11.2	15.1	22.1	29.9	3.5
Intermittent (3x380–440 V) [A]	1.3	2.3	3.9	5.2	6.9	9.1	12.3	16.6	24.3	32.9	3.9
Continuous (3x441–480 V) [A]	1.0	1.8	2.9	3.9	5.3	6.8	9.4	12.6	18.4	24.7	2.9
Intermittent (3x441–480 V) [A]	1.1	2.0	3.2	4.3	5.8	7.5	10.3	13.9	20.2	27.2	3.2
Maximum mains fuses	See chapter 3.2.3 Fuses and Circuit Breakers.										
Estimated power loss [W], best case/typical <sup>1)</sup>	13/15	16/21	46/57	46/58	66/83	95/118	104/131	159/198	248/274	353/379	46/57
Weight enclosure protection rating IP20 [kg (lb)]	2.0 (4.4)	2.0 (4.4)	2.1 (4.6)	3.3 (7.3)	3.3 (7.3)	3.4 (7.5)	4.3 (9.5)	4.5 (9.9)	7.9 (17.4)	7.9 (17.4)	3.3/ (7.3)
Efficiency [%], best case/typical <sup>2)</sup>	97.8/97.3	98.0/97.6	97.7/97.2	98.3/97.9	98.2/97.8	98.0/97.6	98.4/98.0	98.2/97.8	98.1/97.9	98.0/97.8	97.7/97.2
<b>Output current - 50 °C (122 °F) ambient temperature</b>											<b>70 °C (158°F)</b>
Continuous (3x380–440 V) [A]	1.04	1.93	3.7	4.85	6.3	8.4	10.9	14.0	20.9	28.0	3.7
Intermittent (3x380–440 V) [A]	1.1	2.1	4.07	5.4	6.9	9.2	12.0	15.4	23.0	30.8	4.07
Continuous (3x441–480 V) [A]	1.0	1.8	3.4	4.4	5.5	7.5	10.0	12.6	19.1	24.0	3.4
Intermittent (3x441–480 V) [A]	1.1	2.0	3.7	4.8	6.1	8.3	11.0	13.9	21.0	26.4	3.7

**Table 6.3 3x380–480 V AC, 0.37–15 kW (0.5–20 hp), Enclosure Sizes H1–H4**

1) Applies for dimensioning of frequency converter cooling. If the switching frequency is higher than the default setting, the power losses may increase. Keypad and typical control card power consumptions are included.

2) Typical: under rated condition.

Best case: the optimal condition is adopted, such as the higher input voltage and lower switching frequency.

Frequency converter	TR 150							
	P18K	P22K	P30K	P37K	P45K	P55K	P75K	P90K
Typical shaft output [kW]	18.5	22.0	30.0	37.0	45.0	55.0	75.0	90.0
Typical shaft output [hp]	25.0	30.0	40.0	50.0	60.0	70.0	100.0	125.0
Enclosure protection rating IP20	H5	H5	H6	H6	H6	H7	H7	H8
Maximum cable size in terminals (mains, motor) [mm <sup>2</sup> (AWG)]	16 (6)	16 (6)	35 (2)	35 (2)	35 (2)	50 (1)	95 (0)	120 (250MCM)
<b>Output current - 40 °C (104 °F) ambient temperature</b>								
Continuous (3x380–440 V)[A]	37.0	42.5	61.0	73.0	90.0	106.0	147.0	177.0
Intermittent (3x380–440 V) [A]	40.7	46.8	67.1	80.3	99.0	116.0	161.0	194.0
Continuous (3x441–480 V) [A]	34.0	40.0	52.0	65.0	80.0	105.0	130.0	160.0
Intermittent (3x441–480 V) [A]	37.4	44.0	57.2	71.5	88.0	115.0	143.0	176.0
<b>Maximum input current</b>								
Continuous (3x380–440 V) [A]	35.2	41.5	57.0	70.0	84.0	103.0	140.0	166.0
Intermittent (3x380–440 V) [A]	38.7	45.7	62.7	77.0	92.4	113.0	154.0	182.0
Continuous (3x441–480 V) [A]	29.3	34.6	49.2	60.6	72.5	88.6	120.9	142.7
Intermittent (3x441–480 V) [A]	32.2	38.1	54.1	66.7	79.8	97.5	132.9	157.0
Maximum mains fuses	See chapter 3.2.3 Fuses and Circuit Breakers.							
Estimated power loss [W], best case/typical <sup>1)</sup>	412/456	475/523	733	922	1067	1133	1733	2141
Weight enclosure protection rating IP20 [kg (lb)]	9.5 (20.9)	9.5 (20.9)	24.5 (54)	24.5 (54)	24.5 (54)	36.0 (79.4)	36.0 (79.4)	51.0 (112.4)
Efficiency [%], best case/typical <sup>2)</sup>	98.1/97.9	98.1/97.9	97.8	97.7	98	98.2	97.8	97.9
<b>Output current - 50 °C (122 °F) ambient temperature</b>								
Continuous (3x380–440 V) [A]	34.1	38.0	48.8	58.4	72.0	74.2	102.9	123.9
Intermittent (3x380–440 V) [A]	37.5	41.8	53.7	64.2	79.2	81.6	113.2	136.3
Continuous (3x441–480 V) [A]	31.3	35.0	41.6	52.0	64.0	73.5	91.0	112.0
Intermittent (3x441–480 V) [A]	34.4	38.5	45.8	57.2	70.4	80.9	100.1	123.2

**Table 6.4 3x380–480 V AC, 18.5–90 kW (25–125 hp), Enclosure Sizes H5–H8**

1) Applies for dimensioning of frequency converter cooling. If the switching frequency is higher than the default setting, the power losses may increase. Keypad and typical control card power consumptions are included.

2) Efficiency measured at nominal current. For energy efficiency class, see chapter 6.4.10 Ambient Conditions.

## Specifications

### 6.1.3 3x525–600 V AC

Frequency converter	TR150															TR170
	P2K2	P3K0	P3K7	P5K5	P7K5	P11K	P15K	P18K	P22K	P30K	P37K	P45K	P55K	P75K	P90 K	P1K5
Typical shaft output [kW]	2.2	3.0	3.7	5.5	7.5	11.0	15.0	18.5	22.0	30.0	37	45.0	55.0	75.0	90.0	1.5
Typical shaft output [hp]	3.0	4.0	5.0	7.5	10.0	15.0	20.0	25.0	30.0	40.0	50.0	60.0	70.0	100.0	125.0	2.0
Protection rating IP20	H9	H9	H9	H9	H9	H10	H10	H6	H6	H6	H7	H7	H7	H8	H8	H9
Maximum cable size in terminals (mains, motor) [mm <sup>2</sup> (AWG)]	4 (10)	4 (10)	4 (10)	4 (10)	4 (10)	10 (8)	10 (8)	35 (2)	35 (2)	35 (2)	50 (1)	50 (1)	50 (1)	95 (0)	120 (4/0)	4 (10)
<b>Output current - 40 °C (104 °F) ambient temperature</b>																
Continuous (3x525–550 V) [A]	4.1	5.2	6.4	9.5	11.5	19.0	23.0	28.0	36.0	43.0	54.0	65.0	87.0	105.0	137.0	2.9
Intermittent (3x525–550 V) [A]	4.5	5.7	7.0	10.5	12.7	20.9	25.3	30.8	39.6	47.3	59.4	71.5	95.7	115.5	150.7	3.2
Continuous (3x551–600 V) [A]	3.9	4.9	6.1	9.0	11.0	18.0	22.0	27.0	34.0	41.0	52.0	62.0	83.0	100.0	131.0	2.7
Intermittent (3x551–600 V) [A]	4.3	5.4	6.7	9.9	12.1	19.8	24.2	29.7	37.4	45.1	57.2	68.2	91.3	110.0	144.1	3.0
<b>Maximum input current</b>																
Continuous (3x525–550 V) [A]	3.7	5.1	5.0	8.7	11.9	16.5	22.5	27.0	33.1	45.1	54.7	66.5	81.3	109.0	130.9	2.6
Intermittent (3x525–550 V) [A]	4.1	5.6	6.5	9.6	13.1	18.2	24.8	29.7	36.4	49.6	60.1	73.1	89.4	119.9	143.9	2.9
Continuous (3x551–600 V) [A]	3.5	4.8	5.6	8.3	11.4	15.7	21.4	25.7	31.5	42.9	52.0	63.3	77.4	103.8	124.5	2.4
Intermittent (3x551–600 V) [A]	3.9	5.3	6.2	9.2	12.5	17.3	23.6	28.3	34.6	47.2	57.2	69.6	85.1	114.2	137.0	2.6
Maximum mains fuses	See chapter 3.2.3 Fuses and Circuit Breakers.															
Estimated power loss [W], best case/typical <sup>1)</sup>	65	90	110	132	180	216	294	385	458	542	597	727	1092	1380	1658	63
Weight enclosure protection rating IP54 [kg (lb)]	6.6 (14.6)	6.6 (14.6)	6.6 (14.6)	6.6 (14.6)	6.6 (14.6)	11.5 (25.3)	11.5 (25.3)	24.5 (54)	24.5 (54)	24.5 (54)	36.0 (79.3)	36.0 (79.3)	36.0 (79.3)	51.0 (112.4)	51.0 (112.4)	6.6 (14.6)
Efficiency [%], best case/typical <sup>2)</sup>	97.9	97	97.9	98.1	98.1	98.4	98.4	98.4	98.4	98.5	98.5	98.7	98.5	98.5	98.5	96.0
<b>Output current - 50 °C (122 °F) ambient temperature</b>																
Continuous (3x525–550 V) [A]	2.9	3.6	4.5	6.7	8.1	13.3	16.1	19.6	25.2	30.1	37.8	45.5	60.9	73.5	95.9	2.9
Intermittent (3x525–550 V) [A]	3.2	4.0	4.9	7.4	8.9	14.6	17.7	21.6	27.7	33.1	41.6	50.0	67.0	80.9	105.5	3.2
Continuous (3x551–600 V) [A]	2.7	3.4	4.3	6.3	7.7	12.6	15.4	18.9	23.8	28.7	36.4	43.3	58.1	70.0	91.7	2.7
Intermittent (3x551–600 V) [A]	3.0	3.7	4.7	6.9	8.5	13.9	16.9	20.8	26.2	31.6	40.0	47.7	63.9	77.0	100.9	3.0

**Table 6.5 3x525–600 V AC, 2.2–90 kW (3–125 hp), Enclosure Sizes H6–H10**

1) Applies for dimensioning of frequency converter cooling. If the switching frequency is higher than the default setting, the power losses may increase. Keypad and typical control card power consumptions are included.

2) Efficiency measured at nominal current. For energy efficiency class, see chapter 6.4.10 Ambient Conditions.

## 6.2 EMC Emission Test Results

### 6.2.1 EMC Emission Test Results

The following test results have been obtained using a system with a frequency converter, a shielded control cable, a control box with potentiometer, and a shielded motor cable.

RFI Filter Type	Conduct emission. Maximum shielded cable length [m(ft)]						Radiated emission			
	Industrial environment				Housing, trades and light industries		Industrial environment		Housing, trades and light industries	
EN 55011	Class A Group 2		Class A Group 1		Class B		Class A Group 1		Class B	
EN/IEC 61800-3	Category C3 Second environment Industrial		Category C2 First environment Home and office		Category C1 First environment Home and office		Category C2 First environment Home and office		Category C1 First environment Home and office	
	Without external filter	With external filter	Without external filter	With external filter	Without external filter	With external filter	Without external filter	With external filter	Without external filter	With external filter
<b>H4 RFI filter (EN55011 A1, EN/IEC61800-3 C2)</b>										
0.25–11 kW (0.33–15 HP) 3x200–240 V IP20	–	–	25 (82)	50 (164)	–	20 (66)	Yes	Yes	–	No
0.37–22 kW (0.5–30 HP) 3x380–480 V IP20	–	–	25 (82)	50 (164)	–	20 (66)	Yes	Yes	–	No
<b>H2 RFI filter (EN 55011 A2, EN/IEC 61800-3 C3)</b>										
15–45 kW (20–60 HP) 3x200–240 V IP20	25 (82)	–	–	–	–	–	No	–	No	–
30–90 kW 3x380–480 V IP20	25 (82)	–	–	–	–	–	No	–	No	–
<b>H3 RFI filter (EN55011 A1, EN/IEC 61800-3 C1)</b>										
15–45 kW (20–60 HP) 3x200–240 V IP20	–	–	50 (164)	–	20 (66)	–	Yes	–	No	–
30–90 kW (40–125 HP) 3x380–480 V IP20	–	–	50 (164)	–	20 (66)	–	Yes	–	No	–

Table 6.6 EMC Test Results

## 6.3 Special Conditions

### 6.3.1 Derating for Ambient Temperature and Switching Frequency

Ensure that the ambient temperature measured over 24 hours is at least 5 °C (41 °F) lower than the maximum ambient temperature that is specified for the frequency converter. If the frequency converter is operated at a high ambient temperature, decrease the continuous output current. For derating curve, see *TR150 and TR170 Design Guide*.

### 6.3.2 Derating for Low Air Pressure and High Altitudes

The cooling capability of air is decreased at low air pressure. For altitudes above 2000 m (6562 ft), contact Trane regarding PELV. Below 1000 m (3281 ft) altitude, derating is not necessary. For altitudes above 1000 m (3281 ft), decrease the ambient temperature or the maximum output current. Decrease the output by 1% per 100 m (328 ft) altitude above 1000 m (3281 ft) or reduce the maximum ambient temperature by 1 °C (33.8 °F) per 200 m (656 ft).

## 6.4 General Technical Data

### Protection and features

- Electronic motor thermal protection against overload.
- Temperature monitoring of the heat sink ensures that the frequency converter trips if there is overtemperature.
- The frequency converter is protected against short circuits between motor terminals U, V, W.
- When a motor phase is missing, the frequency converter trips and issues an alarm.
- When a mains phase is missing, the frequency converter trips or issues a warning (depending on the load).
- Monitoring of the DC-link voltage ensures that the frequency converter trips when the DC-link voltage is too low or too high.
- The frequency converter is protected against ground faults on motor terminals U, V, W.

### 6.4.1 Mains Supply (L1, L2, L3)

Supply voltage	200–240 V ±10%
Supply voltage	380–480 V ±10%
Supply voltage	525–600 V ±10%
Supply frequency	50/60 Hz
Maximum imbalance temporary between mains phases	3.0% of rated supply voltage
True power factor ( $\lambda$ )	≥0.9 nominal at rated load
Displacement power factor ( $\cos\phi$ ) near unity	(>0.98)
Switching on the input supply L1, L2, L3 (power-ups) enclosure sizes H1–H5	Maximum 1 time/30 s
Switching on the input supply L1, L2, L3 (power-ups) enclosure sizes H6–H10	Maximum 1 time/minute
Environment according to EN 60664-1	Overvoltage category III/pollution degree 2
The unit is suitable for use on a circuit capable of delivering not more than 100000 A <sub>rms</sub> symmetrical Amperes, 240/480 V maximum.	

### 6.4.2 Motor Output (U, V, W)

Output voltage	0–100% of supply voltage
Output frequency	0–400 Hz
Switching on output	Unlimited
Ramp times	0.05–3600 s

### 6.4.3 Cable Length and Cross-section

Maximum motor cable length, shielded/armored (EMC-correct installation)	See <i>chapter 6.2.1 EMC Emission Test Results</i> <i>chapter 6.2 EMC Emission Test Results</i>
Maximum motor cable length, unshielded/unarmored	50 m (164 ft)
Maximum cross-section to motor, mains <sup>1)</sup>	

Cross-section DC terminals for filter feedback on enclosure sizes H1–H3, I2, I3, I4	4 mm <sup>2</sup> /11 AWG
Cross-section DC terminals for filter feedback on enclosure sizes H4–H5	16 mm <sup>2</sup> /6 AWG
Maximum cross-section to control terminals, rigid wire	2.5 mm <sup>2</sup> /14 AWG
Maximum cross-section to control terminals, flexible cable	2.5 mm <sup>2</sup> /14 AWG
Minimum cross-section to control terminals	0.05 mm <sup>2</sup> /30 AWG

1) See *chapter 6.1.2 3x380–480 V AC* for more information.

#### 6.4.4 Digital Inputs

Programmable digital inputs	4
Terminal number	18, 19, 27, 29
Logic	PNP or NPN
Voltage level	0–24 V DC
Voltage level, logic 0 PNP	<5 V DC
Voltage level, logic 1 PNP	>10 V DC
Voltage level, logic 0 NPN	>19 V DC
Voltage level, logic 1 NPN	<14 V DC
Maximum voltage on input	28 V DC
Input resistance, R <sub>i</sub>	Approximately 4 kΩ
Digital input 29 as thermistor input	Fault: >2.9 kΩ and no fault: <800 Ω
Digital input 29 as pulse input	Maximum frequency 32 kHz push-pull-driven & 5 kHz (O.C.)

#### 6.4.5 Analog Inputs

Number of analog inputs	2
Terminal number	53, 54
Terminal 53 mode	<i>Parameter 16-61 Terminal 53 Setting: 1 = voltage, 0 = current</i>
Terminal 54 mode	<i>Parameter 16-63 Terminal 54 Setting: 1 = voltage, 0 = current</i>
Voltage level	0–10 V
Input resistance, R <sub>i</sub>	Approximately 10 kΩ
Maximum voltage	20 V
Current level	0/4–20 mA (scalable)
Input resistance, R <sub>i</sub>	<500 Ω
Maximum current	29 mA
Resolution on analog input	10 bit

#### 6.4.6 Analog Output

Number of programmable analog outputs	2
Terminal number	42, 45 <sup>1)</sup>
Current range at analog output	0/4–20 mA
Maximum load to common at analog output	500 Ω
Maximum voltage at analog output	17 V
Accuracy on analog output	Maximum error: 0.4% of full scale
Resolution on analog output	10 bit

1) *Terminals 42 and 45 can also be programmed as digital outputs.*

#### Digital outputs

Number of digital outputs	4
<b>Terminals 27 and 29</b>	
Terminal number	27, 29 <sup>1)</sup>
Voltage level at digital output	0–24 V
Maximum output current (sink and source)	40 mA
<b>Terminals 42 and 45</b>	
Terminal number	42, 45 <sup>2)</sup>
Voltage level at digital output	17 V
Maximum output current at digital output	20 mA

## Specifications

Maximum load at digital output 1 k $\Omega$

1) Terminals 27 and 29 can also be programmed as input. Terminal 29 can also be programmed as pulse input.

2) Terminals 42 and 45 can also be programmed as analog output.

The digital outputs are galvanically isolated from the supply voltage (PELV) and other high voltage terminals.

### 6.4.7 Control Card, RS485 Serial Communication

Terminal number 68 (P, TX+, RX+), 69 (N, TX-, RX-)

Terminal number 61 common for terminals 68 and 69

### 6.4.8 Control Card, 24 V DC Output

Terminal number 12

Maximum load 80 mA

### 6.4.9 Relay Output

Programmable relay outputs 2

Relay 01 and 02 (enclosure size H1–H5 & I2–I4) 01–03 (NC), 01–02 (NO), 04–06 (NC), 04–05 (NO)

Maximum terminal load (AC-1)<sup>1)</sup> on 01–02/04–05 (NO) (resistive load) 250 V AC, 3 A

Maximum terminal load (AC-15)<sup>1)</sup> on 01–02/04–05 (NO) (inductive load @  $\cos\phi$  0.4)<sup>2)</sup> 250 V AC, 0.2 A

Maximum terminal load (DC-1)<sup>1)</sup> on 01–02/04–05 (NO) (resistive load) 30 V DC, 2 A

Maximum terminal load (DC-13)<sup>1)</sup> on 01–02/04–05 (NO) (inductive load)<sup>2)</sup> 24 V DC, 0.1 A

Maximum terminal load (AC-1)<sup>1)</sup> on 01–03/04–06 (NC) (resistive load) 250 V AC, 3 A

Maximum terminal load (AC-15)<sup>1)</sup> on 01–03/04–06 (NC) (inductive load @  $\cos\phi$  0.4)<sup>2)</sup> 250 V AC, 0.2 A

Maximum terminal load (DC-1)<sup>1)</sup> on 01–03/04–06 (NC) (resistive load) 30 V DC, 2 A

Minimum terminal load on 01–03 (NC), 01–02 (NO) 24 V DC 10 mA, 24 V AC 20 mA

Environment according to EN 60664-1 Overvoltage category III/pollution degree 2

1) IEC 60947 parts 4 and 5. Endurance of the relay varies with different load type, switching current, ambient temperature, driving configuration, working profile, and so forth. It is recommended to mount a snubber circuit when connecting inductive loads to the relays.

2) Only frame sizes H6–H10 and I6–I8.

Programmable relay outputs

Relay 01 terminal number (enclosure size H9) 01–03 (NC), 01–02 (NO)

Maximum terminal load (AC-1)<sup>1)</sup> on 01–03 (NC), 01–02 (NO) (resistive load) 240 V AC, 2 A

Maximum terminal load (AC-15)<sup>1)</sup> (inductive load @  $\cos\phi$  0.4) 240 V AC, 0.2 A

Maximum terminal load (DC-1)<sup>1)</sup> on 01–02 (NO), 01–03 (NC) (resistive load) 60 V DC, 1 A

Maximum terminal load (DC-13)<sup>1)</sup> (inductive load) 24 V DC, 0.1 A

Relay 01 and 02 terminal number (enclosure size H6, H7, H8, H9 (relay 2 only), H10, and I6–I8) 01–03 (NC), 01–02 (NO), 04–06 (NC), 04–05 (NO)

Maximum terminal load (AC-1)<sup>1)</sup> on 04–05 (NO) (resistive load)<sup>2)3)</sup> 400 V AC, 2 A

Maximum terminal load (AC-15)<sup>1)</sup> on 04–05 (NO) (inductive load @  $\cos\phi$  0.4) 240 V AC, 0.2 A

Maximum terminal load (DC-1)<sup>1)</sup> on 04–05 (NO) (resistive load) 80 V DC, 2 A

Maximum terminal load (DC-13)<sup>1)</sup> on 04–05 (NO) (inductive load) 24 V DC, 0.1 A

Maximum terminal load (AC-1)<sup>1)</sup> on 04–06 (NC) (resistive load) 240 V AC, 2 A

Maximum terminal load (AC-15)<sup>1)</sup> on 04–06 (NC) (inductive load @  $\cos\phi$  0.4) 240 V AC, 0.2 A

Maximum terminal load (DC-1)<sup>1)</sup> on 04–06 (NC) (resistive load) 50 V DC, 2 A

Maximum terminal load (DC-13)<sup>1)</sup> on 04–06 (NC) (inductive load) 24 V DC, 0.1 A

Minimum terminal load on 01–03 (NC), 01–02 (NO), 04–06 (NC), 04–05 (NO) 24 V DC 10 mA, 24 V AC 20 mA

Environment according to EN 60664-1 Overvoltage category III/pollution degree 2

1) IEC 60947 parts 4 and 5. Endurance of the relay varies with different load type, switching current, ambient temperature, driving configuration, working profile, and so forth. It is recommended to mount a snubber circuit when connecting inductive loads to the relays.

2) Overvoltage Category II.

3) UL applications 300 V AC 2 A.

Control Card, 10 V DC Output

Terminal number	50
Output voltage	10.5 V $\pm$ 0.5 V
Maximum load	25 mA

### 6.4.10 Ambient Conditions

Enclosure protection rating	IP20, IP54 (Not for outdoor installation)
Enclosure kit available	IP21, TYPE 1
Vibration test	1.0 g
Maximum relative humidity	5–95% (IEC 60721-3-3; Class 3K3 (non-condensing)) during operation
Aggressive environment (IEC 60721-3-3), coated (standard) enclosure sizes H1–H5	Class 3C3
Aggressive environment (IEC 60721-3-3), non-coated enclosure sizes H6–H10	Class 3C2
Aggressive environment (IEC 60721-3-3), coated (optional) enclosure sizes H6–H10	Class 3C3
Aggressive environment (IEC 60721-3-3), non-coated enclosure sizes I2–I8	Class 3C2
Test method according to IEC 60068-2-43 H2S (10 days)	
Ambient temperature <sup>1)</sup>	See maximum output current at 40/50/70 °C (104/122/158 °F) in <i>chapter 6.1.2 3x380–480 V AC</i> .
Minimum ambient temperature during full-scale operation	0 °C (32 °F)
Minimum ambient temperature at reduced performance, enclosure sizes H1–H5 and I2–I4	-20 °C (-4 °F)
Minimum ambient temperature at reduced performance, enclosure sizes H6–H10 and I6–I8	-10 °C (14 °F)
Temperature during storage/transport	-30 to +65/70 °C (-22 to +149/158°F)
Maximum altitude above sea level without derating	1000 m (3281 ft)
Maximum altitude above sea level with derating	3000 m (9843 ft)
Derating for high altitude, see <i>chapter 6.3.2 Derating for Low Air Pressure and High Altitudes</i> .	
Safety standards	EN/IEC 61800-5-1, UL 508C
EMC standards, Emission	EN 61800-3, EN 61000-6-3/4, EN 55011, IEC 61800-3 EN 61800-3, EN 61000-3-12, EN 61000-6-1/2, EN 61000-4-2, EN 61000-4-3, EN 61000-4-4,
EMC standards, Immunity	EN 61000-4-5, EN 61000-4-6
Energy efficiency class <sup>2)</sup>	IE2

1) Refer to *Special Conditions in the design guide* for:

- Derating for high ambient temperature.
- Derating for high altitude.

2) Determined according to EN 50598-2 at:

- Rated load.
- 90% rated frequency.
- Switching frequency factory setting.
- Switching pattern factory setting.



## Index

<b>A</b>	
Ambient condition.....	47
<b>C</b>	
Cable	
length.....	44
Circuit breaker.....	13
Connecting to motor.....	9
Control card	
Control card 10 V DC output.....	47
Control card 24 V DC output.....	46
RS485 serial communication.....	46
Cross-section.....	44
<b>D</b>	
Discharge time.....	4
Display.....	18
Disposal instruction.....	3
<b>E</b>	
Efficiency.....	40
Electrical installation.....	8
Energy efficiency.....	38, 39, 41, 42
Energy efficiency class.....	47
<b>F</b>	
Fuse.....	13
<b>H</b>	
High voltage.....	4
<b>I</b>	
Indicator light.....	18
Inputs	
Analog input.....	45
Digital input.....	45
Installation.....	14
<b>K</b>	
Keypad.....	18
<b>L</b>	
L1, L2, L3.....	44
Leakage current.....	5
Load sharing.....	4
<b>M</b>	
Mains supply (L1, L2, L3).....	44
Mains supply 3x200–240 V AC.....	38, 39
Mains supply 3x380–480 V AC.....	40
Mains supply 3x525–600 V AC.....	42
Menu key.....	18
Motor	
overload protection.....	44
Output (U, V, W).....	44
<b>N</b>	
Navigation key.....	18
<b>O</b>	
Operation key.....	18
Outputs	
Analog output.....	45
Digital output.....	45
Overcurrent protection.....	13
<b>P</b>	
Programming	
Programming.....	18
Protection.....	13, 44
<b>Q</b>	
Qualified personnel.....	4
<b>S</b>	
Safety.....	5
Side-by-side installation.....	6
<b>T</b>	
Terminals	
Terminal 50.....	47
Thermal protection.....	3
<b>U</b>	
UL compliance.....	13
Unintended start.....	4
<b>W</b>	
Warning and alarm list.....	36
Wiring schematic.....	17





Ingersoll Rand (NYSE:IR) advances the quality of life by creating comfortable, sustainable and efficient environments. Our people and our family of brands—including Club Car®, Ingersoll Rand®, Thermo King® and Trane®—work together to enhance the quality and comfort of air in homes and buildings; transport and protect food and perishables; and increase industrial productivity and efficiency. We are a global business committed to a world of sustainable progress and enduring results.



[ingersollrand.com](http://ingersollrand.com)

Ingersoll Rand has a policy of continuous product and product data improvement and reserves the right to change design and specifications without notice.  
We are committed to using environmentally conscious print practices.

BAS-SVX58C-EN 20 Jan 2019  
Supersedes BAS-SVX58B-EN (Sep 2016)

©2019 Ingersoll Rand

