



# Programming Guide

## TR150 and TR170

### SAFETY WARNING

Only qualified personnel should install and service the equipment. The installation, starting up, and servicing of heating, ventilating, and air-conditioning equipment can be hazardous and requires specific knowledge and training. Improperly installed, adjusted or altered equipment by an unqualified person could result in death or serious injury. When working on the equipment, observe all precautions in the literature and on the tags, stickers, and labels that are attached to the equipment.

## Contents

<b>1 Introduction</b>	<b>3</b>
1.1 Purpose of the Manual	3
1.2 Document and Software Version	3
1.3 Safety Symbols	3
1.4 Safety Precautions	3
1.5 Additional Resources	4
1.6 Definitions	5
1.7 Electrical Overview	7
<b>2 Programming</b>	<b>8</b>
2.1 Introduction	8
2.2 Keypad	8
2.3 Menus	9
2.3.1 Status Menu	9
2.3.2 Quick Menu	9
2.3.3 Main Menu	23
2.4 Quick Transfer of Parameter Settings between Multiple Frequency Converters	23
2.5 Readout and Programming of Indexed Parameters	24
2.6 Initialization to Default Settings	24
<b>3 Parameters</b>	<b>25</b>
3.1 Main Menu - Operation and Display - Group 0	25
3.2 Main Menu - Load and Motor - Group 1	29
3.3 Main Menu - Brakes - Group 2	39
3.4 Main Menu - Reference/Ramps - Group 3	40
3.5 Main Menu - Limits/Warnings - Group 4	42
3.6 Main Menu - Digital In/Out - Group 5	45
3.7 Main Menu - Analog In/Out - Group 6	54
3.8 Main Menu - Communications and Options - Group 8	60
3.9 Main Menu - Smart Logic - Group 13	66
3.10 Main Menu - Special Functions - Group 14	74
3.11 Main Menu - Drive Information - Group 15	78
3.12 Main Menu - Data Readouts - Group 16	80
3.13 Main Menu - Data Readouts 2 - Group 18	84
3.14 Main Menu - FC Closed Loop - Group 20	84
3.15 Main Menu - Application Functions - Group 22	87
3.16 Main Menu - Application Functions 2 - Group 24	94
3.17 Main Menu - Special Features - Group 30	97
<b>4 Troubleshooting</b>	<b>98</b>

4.1 Introduction to Alarms and Warnings	98
4.2 Alarm Words	100
4.3 Warning Words	100
4.4 Extended Status Words	101
4.5 List of Warnings and Alarms	101
4.6 List of Keypad Errors	104
<b>5 Parameter Lists</b>	<b>105</b>
5.1 Parameter Options	105
5.1.1 Default Settings	105
5.1.2 0-** Operation/Display	106
5.1.3 1-** Load and Motor	106
5.1.4 2-** Brakes	108
5.1.5 3-** Reference/Ramps	108
5.1.6 4-** Limits/Warnings	109
5.1.7 5-** Digital In/Out	109
5.1.8 6-** Analog In/Out	110
5.1.9 8-** Comm. and Options	111
5.1.10 13-** Smart Logic	112
5.1.11 14-** Special Functions	112
5.1.12 15-** Drive Information	113
5.1.13 16-** Data Readouts	114
5.1.14 18-** Info & Readouts	115
5.1.15 20-** Drive Closed Loop	115
5.1.16 22-** Appl. Functions	116
5.1.17 24-** Appl. Functions 2	117
5.1.18 30-** Special Features	117
<b>Index</b>	<b>118</b>

# 1 Introduction

## 1.1 Purpose of the Manual

This programming guide provides information for advanced programming of the frequency converter. It provides a complete overview and description of all parameters.

The programming guide is intended for use by qualified personnel.

To operate the frequency converter safely and professionally, read and follow the programming guide, and pay particular attention to the safety instructions and general warnings.

## 1.2 Document and Software Version

This manual is regularly reviewed and updated. All suggestions for improvement are welcome.

Edition	Remarks	Software version
BAS-SVP16C-EN	Update to new software version.	4.2x

Table 1.1 Document and Software Version

Software version 4.0x and higher introduced variable speed cooling fans for longer life and reduced fan noise under many operating conditions. Introduction of this feature required new control cards that are not compatible with older versions of software. Refer to *Table 1.2* for hardware/software compatibility.

Frame Size	Approximate date of production conversion	Old version	New version
H1, H2, H3, H4, H5	Week 26, 2018	Must use software version 3.xx or below	Must use software version 4.xx or higher
H6, H7, H8, H9, H10	Week 37, 2018		

Table 1.2 Hardware and Software Compatibility

## 1.3 Safety Symbols

The following symbols are used in this guide:



Indicates a potentially hazardous situation that could result in death or serious injury.



Indicates a potentially hazardous situation that could result in minor or moderate injury. It can also be used to alert against unsafe practices.



Indicates important information, including situations that can result in damage to equipment or property.

## 1.4 Safety Precautions



### HIGH VOLTAGE

Drives contain high voltage when connected to AC mains input, DC supply, or load sharing. Failure to perform installation, start-up, and maintenance by qualified personnel can result in death or serious injury.

- Only qualified personnel must perform installation, start-up, and maintenance.
- Before performing any service or repair work, use an appropriate voltage measuring device to make sure that there is no remaining voltage on the drive.



### UNINTENDED START

When the drive is connected to AC mains, DC supply, or load sharing, the motor can start at any time. Unintended start during programming, service, or repair work can result in death, serious injury, or property damage. The motor can start with an external switch, a fieldbus command, an input reference signal from the keypad or LOP, via remote operation using Trane Drive Utility (TDU), or after a cleared fault condition.

To prevent unintended motor start:

- Press [Off/Reset] on the keypad before programming parameters.
- Disconnect the drive from the mains.
- Completely wire and assemble the drive, motor, and any driven equipment before connecting the drive to AC mains, DC supply, or load sharing.

**⚠ WARNING**

**DISCHARGE TIME**

The frequency converter contains DC-link capacitors, which can remain charged even when the frequency converter is not powered. High voltage can be present even when the warning LED indicator lights are off. Failure to wait the specified time after power has been removed before performing service or repair work can result in death or serious injury.

- Stop the motor.
- Disconnect AC mains and remote DC-link power supplies, including battery back-ups, UPS, and DC-link connections to other frequency converters.
- Disconnect or lock PM motor.
- Wait for the capacitors to discharge fully. The minimum duration of waiting time is specified in *Table 1.3*.
- Before performing any service or repair work, use an appropriate voltage measuring device to make sure that the capacitors are fully discharged.

Voltage [V]	Power range [kW (hp)]	Minimum waiting time (minutes)
3x200	0.25–3.7 (0.33–5)	4
3x200	5.5–11 (7–15)	15
3x400	0.37–7.5 (0.5–10)	4
3x400	11–90 (15–125)	15
3x600	1.5–7.5 (2–10)	4
3x600	11–90 (15–125)	15

Table 1.3 Discharge Time

**⚠ WARNING**

**LEAKAGE CURRENT HAZARD**

Leakage currents exceed 3.5 mA. Failure to ground the drive properly can result in death or serious injury.

- Ensure the correct grounding of the equipment by a certified electrical installer.

**⚠ WARNING**

**EQUIPMENT HAZARD**

Contact with rotating shafts and electrical equipment can result in death or serious injury.

- Ensure that only trained and qualified personnel perform installation, start-up, and maintenance.
- Ensure that electrical work conforms to national and local electrical codes.
- Follow the procedures in this manual.

**⚠ CAUTION**

**INTERNAL FAILURE HAZARD**

An internal failure in the drive can result in serious injury when the drive is not properly closed.

- Ensure that all safety covers are in place and securely fastened before applying power.

1.5 Additional Resources

- *TR150 and TR170 Quick Guide* provides basic information on mechanical dimensions, installation, and programming.
- *TR150 and TR170 Design Guide* provides information on how to design motor control systems.
- The Trane Drive Energy Analysis Program is available at [www.TraneDrives.com](http://www.TraneDrives.com). The software allows energy consumption comparisons of HVAC fans and pumps driven by Trane frequency converters and alternative methods of flow control. Use this tool to project the costs, savings, and payback of using Trane frequency converters on HVAC fans, pumps, and cooling towers.

It is also available online at: [www.trane.com/vfd](http://www.trane.com/vfd).

**Trane Drive Utility (TDU) support**

Download the software from [www.trane.com/vfd](http://www.trane.com/vfd).

During the installation process of the software, enter CD key 52314600. A license key is not required for basic operation. For advanced features enter license key 11131111.

The latest software does not always contain the latest updates for frequency converters. Contact the local sales office for the latest frequency converter updates (in the form of \*.upd files), or download the frequency converter updates from [www.tranedrives.com](http://www.tranedrives.com).

## 1.6 Definitions

### Frequency converter

#### $I_{DRIVE, MAX}$

The maximum output current.

#### $I_{DRIVE, N}$

The rated output current supplied by the frequency converter.

#### $U_{DRIVE, MAX}$

The maximum output voltage.

### Input

The connected motor can start and stop via keypad and digital inputs. Functions are divided into 2 groups, as described in *Table 1.4*. Functions in group 1 have higher priority than functions in group 2.

Group 1	Reset, coast stop, reset and coast stop, quick stop, DC brake, stop, and [Off].
Group 2	Start, pulse start, reversing, start reversing, jog, and freeze output.

Table 1.4 Control Commands

### Motor

#### $f_{JOG}$

The motor frequency when the jog function is activated (via digital terminals).

#### $f_M$

The motor frequency.

#### $f_{MAX}$

The maximum motor frequency.

#### $f_{MIN}$

The minimum motor frequency.

#### $f_{M,N}$

The rated motor frequency (nameplate data).

#### $I_M$

The motor current.

#### $I_{M,N}$

The rated motor current (nameplate data).

#### $n_{M,N}$

The nominal motor speed (nameplate data).

#### $P_{M,N}$

The rated motor power (nameplate data).

#### $U_M$

The instantaneous motor voltage.

#### $U_{M,N}$

The rated motor voltage (nameplate data).

### Break-away torque

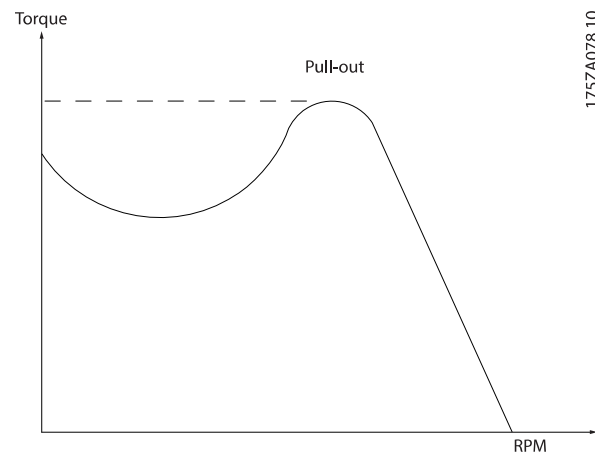

175ZA078:10

Illustration 1.1 Break-away Torque

### $\eta_{DRIVE}$

The efficiency of the frequency converter is defined as the ratio between the power output and the power input.

### Start-disable command

A stop command belonging to the group 1 control commands, see *Table 1.4*.

### Stop command

See *Table 1.4*.

### Analog reference

A signal transmitted to the analog inputs 53 or 54. It can be voltage or current.

- Current input: 0–20 mA and 4–20 mA
- Voltage input: 0–10 V DC

### Bus reference

A signal transmitted to the serial communication port (drive port).

### Preset reference

A defined preset reference to be set from -100% to +100% of the reference range. Selection of 8 preset references via the digital terminals.

### $Ref_{MAX}$

Determines the relationship between the reference input at 100% full scale value (typically 10 V, 20 mA) and the resulting reference. The maximum reference value set in *parameter 3-03 Maximum Reference*.

### $Ref_{MIN}$

Determines the relationship between the reference input at 0% value (typically 0 V, 0 mA, 4 mA) and the resulting reference. The minimum reference value is set in *parameter 3-02 Minimum Reference*.

### Analog inputs

The analog inputs are used for controlling various functions of the frequency converter.

There are 2 types of analog inputs:

- Current input: 0–20 mA and 4–20 mA
- Voltage input: 0–10 V DC

**Analog outputs**

The analog outputs can supply a signal of 0–20 mA, 4–20 mA, or a digital signal.

**Automatic motor adaptation, AMA**

The AMA algorithm determines the electrical parameters for the connected motor at standstill and compensates for the resistance based on the length of the motor cable.

**Digital inputs**

The digital inputs can be used for controlling various functions of the frequency converter.

**Digital outputs**

The frequency converter provides 2 solid-state outputs that can supply a 24 V DC (maximum 40 mA) signal.

**Relay outputs**

The frequency converter provides 2 programmable relay outputs.

**ETR**

Electronic thermal relay is a thermal load calculation based on present load and time. Its purpose is to estimate the motor temperature and prevent overheating of the motor.

**Initializing**

If initializing is carried out (*parameter 14-22 Operation Mode*), the programmable parameters of the frequency converter return to their default settings.

*Parameter 14-22 Operation Mode* does not initialize communication parameters, fault log, or fire mode log.

**Intermittent duty cycle**

An intermittent duty rating refers to a sequence of duty cycles. Each cycle consists of an on-load and an off-load period. The operation can be either periodic duty or non-periodic duty.

**Keypad**

The keypad makes up a complete interface for control and programming of the frequency converter. The keypad is detachable on IP20 units and fixed on IP54 units. It can be installed up to 3 m (9.8 ft) from the frequency converter, that is, in a front panel with the installation kit option.

**Lsb**

Least significant bit.

**MCM**

Short for mille circular mil, an American measuring unit for cable cross-section. 1 MCM = 0.5067 mm<sup>2</sup>.

**Msb**

Most significant bit.

**On-line/Off-line parameters**

Changes to on-line parameters are activated immediately after the data value is changed. Press [OK] to activate off-line parameters.

**PI controller**

The PI controller maintains the desired speed, pressure, temperature, and so on, by adjusting the output frequency to match the varying load.

**RCD**

Residual current device.

**Set-up**

Parameter settings in 2 set-ups can be saved. Change between the 2 parameter set-ups and edit 1 set-up, while another set-up is active.

**Slip compensation**

The frequency converter compensates for the motor slip by giving the frequency a supplement that follows the measured motor load keeping the motor speed almost constant.

**Smart logic control (SLC)**

The SLC is a sequence of user-defined actions executed when the associated user-defined events are evaluated as true by the SLC.

**Thermistor**

A temperature-dependent resistor placed where the temperature is to be monitored (frequency converter or motor).

**Trip**

A state entered in fault situations, for example, if the frequency converter is subject to an overtemperature or when the frequency converter is protecting the motor, process, or mechanism. Restart is prevented until the cause of the fault does not exist and the trip state is canceled by activating reset or, sometimes, by being programmed to reset automatically. Do not use trip for personal safety.

**Trip lock**

A state entered in fault situations when the frequency converter is protecting itself and requiring physical intervention, for example, if the frequency converter is subject to a short circuit on the output. A locked trip can only be canceled by cutting off mains, removing the cause of the fault, and reconnecting the frequency converter. Restart is prevented until the trip state is canceled by activating reset or, sometimes, by being programmed to reset automatically. Do not use trip lock for personal safety.

**VT characteristics**

Variable torque characteristics used for pumps and fans.

**VVC<sup>+</sup>**

If compared with standard voltage/frequency ratio control, voltage vector control (VVC<sup>+</sup>) improves the dynamics and the stability, both when the speed reference is changed and in relation to the load torque.

### 1.7 Electrical Overview

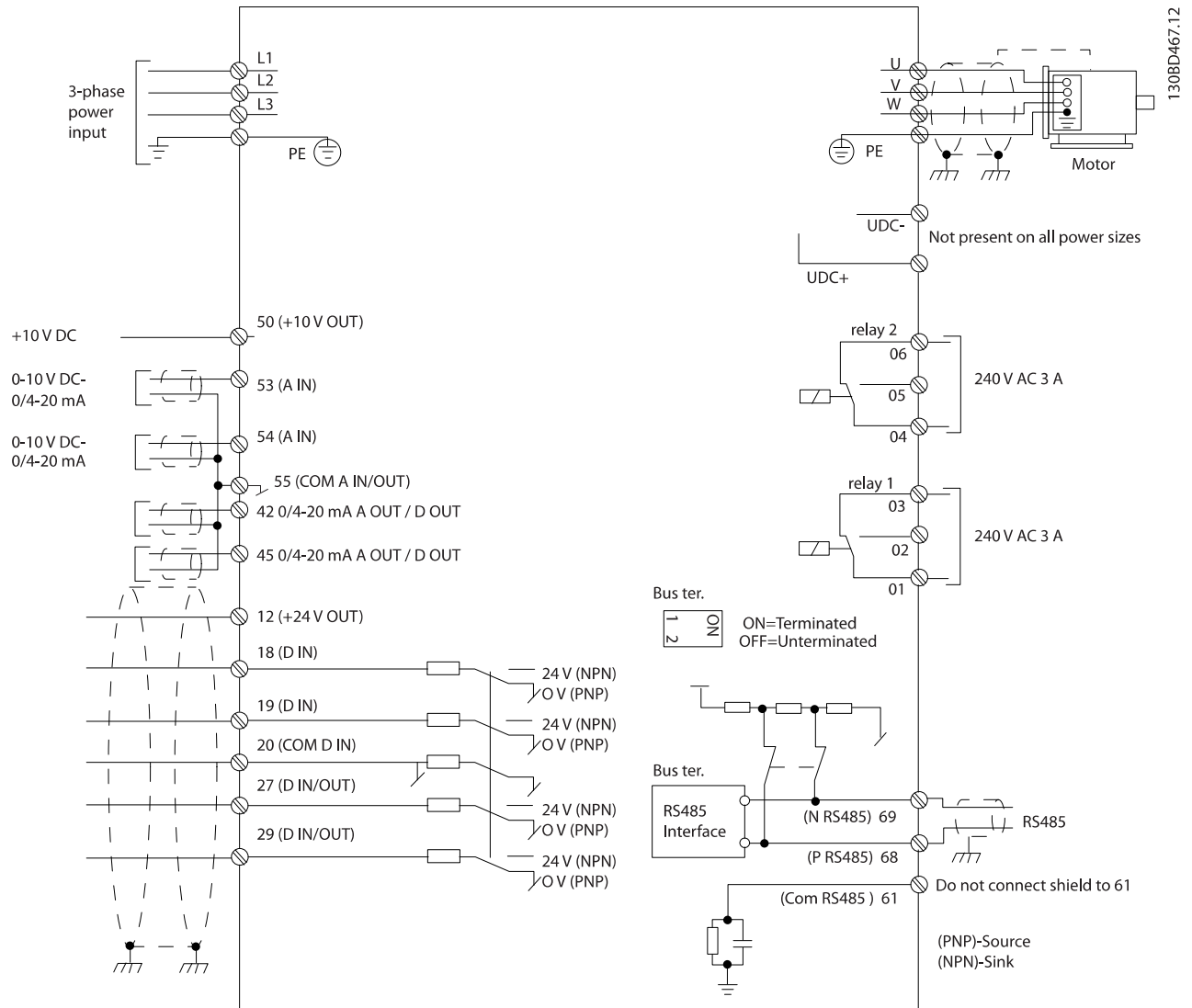

Illustration 1.2 Basic Wiring Schematic Drawing

### NOTICE

There is no access to UDC- and UDC+ on the following units:

- IP20, 380–480 V, 30–90 kW (40–125 hp)
- IP20, 200–240 V, 15–45 kW (20–60 hp)
- IP20, 525–600 V, 1.5–90 kW (2.0–125 hp)
- IP54, 380–480 V, 22–90 kW (30–125 hp)



## 2 Programming

### 2

### 2.1 Introduction

The frequency converter can be programmed from the Keypad or from a PC via the RS485 COM port by installing the Trane Drive Utility (TDU). Refer to *chapter 1.5 Additional Resources* for more details about the software.

### 2.2 Keypad

The keypad is divided into 4 functional sections.

- A. Display
- B. Menu key
- C. Navigation keys and indicator lights
- D. Operation keys and indicator lights

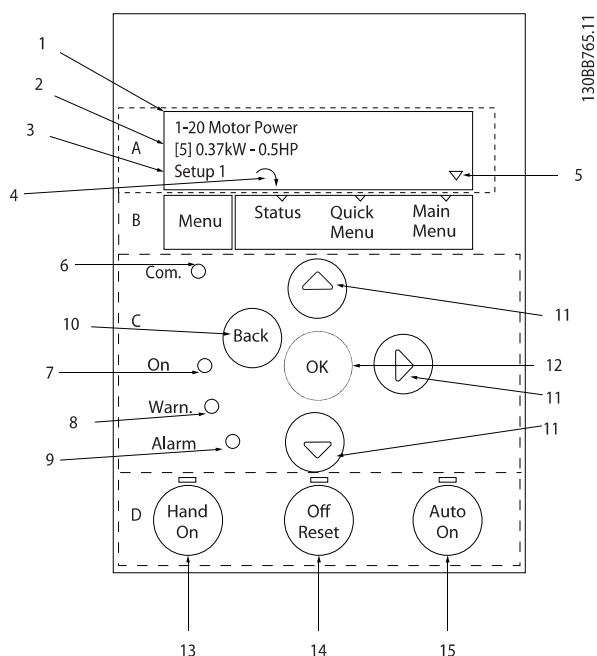

Illustration 2.1 Keypad

#### A. Display

The LCD display is illuminated with 2 alphanumeric lines. All data is shown on the keypad.

Illustration 2.1 describes the information that can be read from the display.

1	Parameter number and name.
2	Parameter value.
3	Set-up number shows the active set-up and the edit set-up. If the same set-up acts as both active and edit set-up, only that set-up number is shown (factory setting). When active and edit set-up differ, both numbers are shown in the display (set-up 12). The number flashing indicates the edit set-up.
4	Motor direction is shown to the bottom left of the display – indicated by a small arrow pointing either clockwise or counterclockwise.
5	The triangle indicates if the keypad is in Status, Quick Menu, or Main Menu.

Table 2.1 Legend to Illustration 2.1, Part I

#### B. Menu key

Press [Menu] to select among Status, Quick Menu, or Main Menu.

#### C. Navigation keys and indicator lights

6	Com. LED: Flashes during bus communication.
7	Green LED/On: Control section is working correctly.
8	Yellow LED/Warn.: Indicates a warning.
9	Flashing Red LED/Alarm: Indicates an alarm.
10	[Back]: For moving to the previous step or layer in the navigation structure.
11	[▲] [▼] [▶]: For navigating among parameter groups and parameters, and within parameters. They can also be used for setting local reference.
12	[OK]: For selecting a parameter and for accepting changes to parameter settings.

Table 2.2 Legend to Illustration 2.1, Part II

#### D. Operation keys and indicator lights

13	[Hand On]: Starts the motor and enables control of the frequency converter via the keypad. <b>NOTICE</b> [2] Coast inverse is the default option for parameter 5-12 Terminal 27 Digital Input. If there is no 24 V supply to terminal 27, [Hand On] does not start the motor. Connect terminal 12 to terminal 27.
14	[Off/Reset]: Stops the motor (Off). If in alarm mode, the alarm is reset.
15	[Auto On]: The frequency converter is controlled either via control terminals or serial communication.

Table 2.3 Legend to Illustration 2.1, Part III

## 2.3 Menus

### 2.3.1 Status Menu

In the *Status* menu, the selection options are:

- Motor frequency [Hz], *parameter 16-13 Frequency*.
- Motor current [A], *parameter 16-14 Motor current*.
- Motor speed reference in percentage [%], *parameter 16-02 Reference [%]*.
- Feedback, *parameter 16-52 Feedback[Unit]*.
- Motor power, *parameter 16-10 Power [kW]* for kW, *parameter 16-11 Power [hp]* for hp. If *parameter 0-03 Regional Settings* is set to [1] North America, motor power is shown in hp instead of kW.
- Custom readout, *parameter 16-09 Custom Readout*.
- Motor Speed [RPM], *parameter 16-17 Speed [RPM]*.

again through the quick menu. Press [OK] to start the wizard. Press [Back] to return to the status view.



Illustration 2.3 Start-up/Quit Wizard

### 2.3.2 Quick Menu

Use the Quick Menu to program the most common functions. The Quick Menu consists of:

- Wizard for open loop applications. See *Illustration 2.4* for details.
- Wizard for closed loop applications. See *Illustration 2.5* for details.
- Motor set-up. See *Table 2.6* for details.
- Changes made.

The built-in wizard menu guides the installer through the set-up of the frequency converter in a clear and structured manner for open-loop applications, closed-loop applications, and quick motor settings.

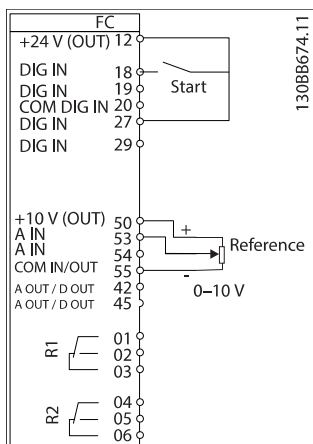
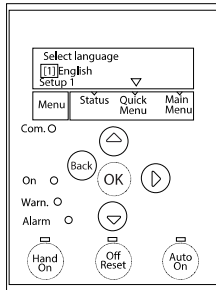

Illustration 2.2 Frequency Converter Wiring

The wizard is shown after power-up until any parameter has been changed. The wizard can always be accessed

At power-up, select the preferred language.



Power-up Screen



The next screen is the Wizard screen.

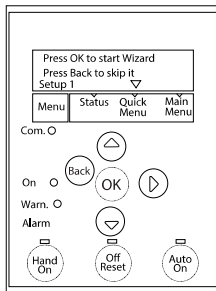

Wizard Screen

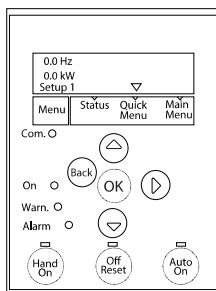

Status Screen

The Wizard can always be reentered via the Quick Menu

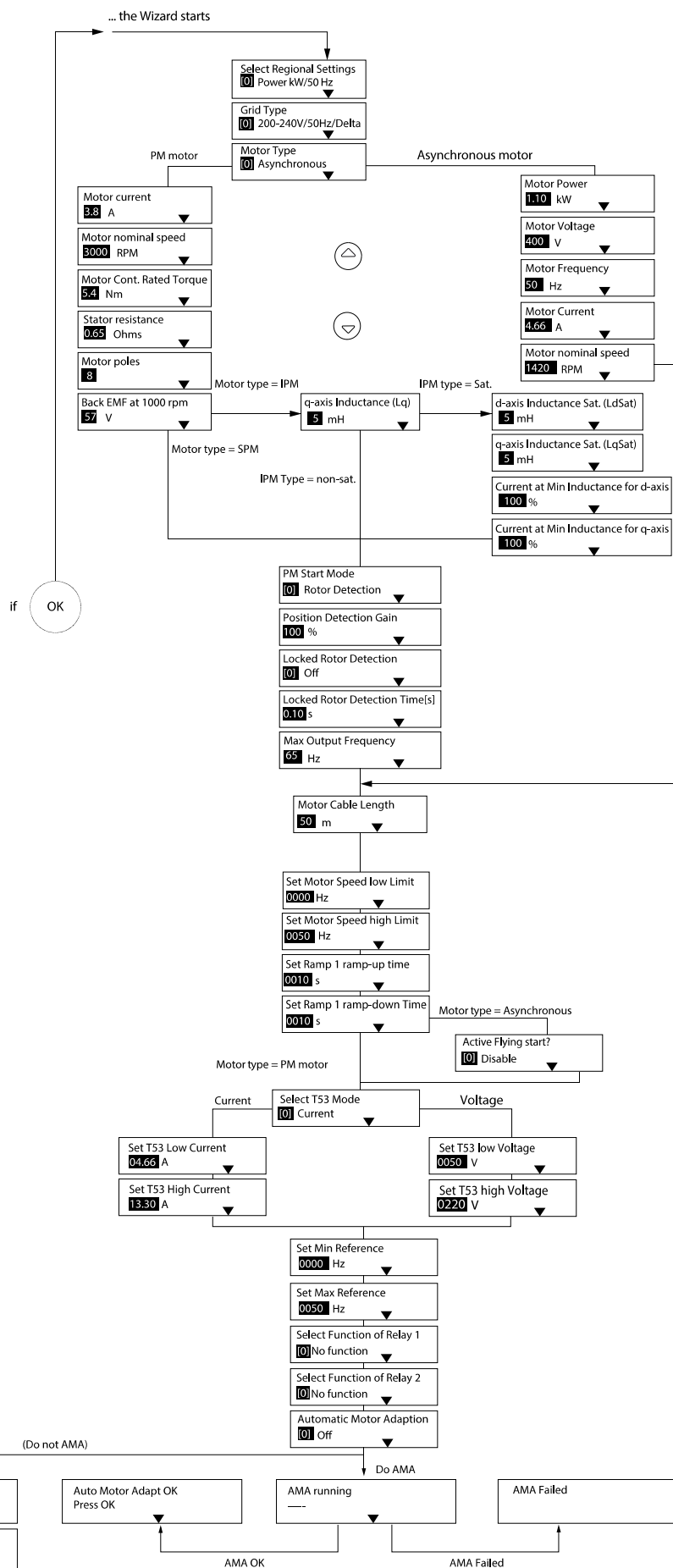

130BC244.14

Illustration 2.4 Set-up Wizard for Open-loop Applications

Set-up Wizard for Open-loop Applications

Parameter	Option	Default	Usage
Parameter 0-03 Regional Settings	[0] International [1] US	[0] International	–
Parameter 0-06 GridType	[0] 200–240 V/50 Hz/IT-grid [1] 200–240 V/50 Hz/Delta [2] 200–240 V/50 Hz [10] 380–440 V/50 Hz/IT-grid [11] 380–440 V/50 Hz/Delta [12] 380–440 V/50 Hz [20] 440–480 V/50 Hz/IT-grid [21] 440–480 V/50 Hz/Delta [22] 440–480 V/50 Hz [30] 525–600 V/50 Hz/IT-grid [31] 525–600 V/50 Hz/Delta [32] 525–600 V/50 Hz [100] 200–240 V/60 Hz/IT-grid [101] 200–240 V/60 Hz/Delta [102] 200–240 V/60 Hz [110] 380–440 V/60 Hz/IT-grid [111] 380–440 V/60 Hz/Delta [112] 380–440 V/60 Hz [120] 440–480 V/60 Hz/IT-grid [121] 440–480 V/60 Hz/Delta [122] 440–480 V/60 Hz [130] 525–600 V/60 Hz/IT-grid [131] 525–600 V/60 Hz/Delta [132] 525–600 V/60 Hz	Size related	Select the operating mode for restart after reconnection of the frequency converter to mains voltage after power-down.

Parameter	Option	Default	Usage
Parameter 1-10 Motor Construction	*[0] Asynchron [1] PM, non-salient SPM [3] PM, salient IPM	[0] Asynchron	<p>Setting the parameter value might change these parameters:</p> <ul style="list-style-type: none"> <li>• Parameter 1-01 Motor Control Principle.</li> <li>• Parameter 1-03 Torque Characteristics.</li> <li>• Parameter 1-08 Motor Control Bandwidth.</li> <li>• Parameter 1-14 Damping Gain.</li> <li>• Parameter 1-15 Low Speed Filter Time Const.</li> <li>• Parameter 1-16 High Speed Filter Time Const.</li> <li>• Parameter 1-17 Voltage filter time const.</li> <li>• Parameter 1-20 Motor Power.</li> <li>• Parameter 1-22 Motor Voltage.</li> <li>• Parameter 1-23 Motor Frequency.</li> <li>• Parameter 1-24 Motor Current.</li> <li>• Parameter 1-25 Motor Nominal Speed.</li> <li>• Parameter 1-26 Motor Cont. Rated Torque.</li> <li>• Parameter 1-30 Stator Resistance (Rs).</li> <li>• Parameter 1-33 Stator Leakage Reactance (X1).</li> <li>• Parameter 1-35 Main Reactance (Xh).</li> <li>• Parameter 1-37 d-axis Inductance (Ld).</li> <li>• Parameter 1-38 q-axis Inductance (Lq).</li> <li>• Parameter 1-39 Motor Poles.</li> <li>• Parameter 1-40 Back EMF at 1000 RPM.</li> <li>• Parameter 1-44 d-axis Inductance Sat. (LdSat).</li> <li>• Parameter 1-45 q-axis Inductance Sat. (LqSat).</li> <li>• Parameter 1-46 Position Detection Gain.</li> <li>• Parameter 1-48 Current at Min Inductance for d-axis.</li> <li>• Parameter 1-49 Current at Min Inductance for q-axis.</li> <li>• Parameter 1-66 Min. Current at Low Speed.</li> <li>• Parameter 1-70 Start Mode.</li> <li>• Parameter 1-72 Start Function.</li> <li>• Parameter 1-73 Flying Start.</li> <li>• Parameter 1-80 Function at Stop.</li> <li>• Parameter 1-82 Min Speed for Function at Stop [Hz].</li> <li>• Parameter 1-90 Motor Thermal Protection.</li> <li>• Parameter 2-00 DC Hold/Motor Preheat Current.</li> <li>• Parameter 2-01 DC Brake Current.</li> <li>• Parameter 2-02 DC Braking Time.</li> <li>• Parameter 2-04 DC Brake Cut In Speed.</li> <li>• Parameter 2-10 Brake Function.</li> <li>• Parameter 4-14 Motor Speed High Limit [Hz].</li> <li>• Parameter 4-19 Max Output Frequency.</li> <li>• Parameter 4-58 Missing Motor Phase Function.</li> <li>• Parameter 14-65 Speed Derate Dead Time Compensation.</li> </ul>

Parameter	Option	Default	Usage
Parameter 1-20 Motor Power	0.12–110 kW/0.16–150 hp	Size related	Enter the motor power from the nameplate data.
Parameter 1-22 Motor Voltage	50–1000 V	Size related	Enter the motor voltage from the nameplate data.
Parameter 1-23 Motor Frequency	20–400 Hz	Size related	Enter the motor frequency from the nameplate data.
Parameter 1-24 Motor Current	0.01–10000.00 A	Size related	Enter the motor current from the nameplate data.
Parameter 1-25 Motor Nominal Speed	50–9999 RPM	Size related	Enter the motor nominal speed from the nameplate data.
Parameter 1-26 Motor Cont. Rated Torque	0.1–1000.0 Nm	Size related	This parameter is available when <i>parameter 1-10 Motor Construction</i> is set to options that enable permanent magnet motor mode. <b>NOTICE</b> Changing this parameter affects the settings of other parameters.
Parameter 1-29 Automatic Motor Adaption (AMA)	See <i>parameter 1-29 Automatic Motor Adaption (AMA)</i> .	Off	Performing an AMA optimizes motor performance.
Parameter 1-30 Stator Resistance (Rs)	0.000–99.990 Ω	Size related	Set the stator resistance value.
Parameter 1-37 d-axis Inductance (Ld)	0.000–1000.000 mH	Size related	Enter the value of the d-axis inductance. Obtain the value from the permanent magnet motor datasheet.
Parameter 1-38 q-axis Inductance (Lq)	0.000–1000.000 mH	Size related	Enter the value of the q-axis inductance.
Parameter 1-39 Motor Poles	2–100	4	Enter the number of motor poles.
Parameter 1-40 Back EMF at 1000 RPM	10–9000 V	Size related	Line-line RMS back EMF voltage at 1000 RPM.
Parameter 1-42 Motor Cable Length	0–100 m	50 m	Enter the motor cable length.
Parameter 1-44 d-axis Inductance Sat. (LdSat)	0.000–1000.000 mH	Size related	This parameter corresponds to the inductance saturation of Ld. Ideally, this parameter has the same value as <i>parameter 1-37 d-axis Inductance (Ld)</i> . However, if the motor supplier provides an induction curve, enter the induction value, which is 200% of the nominal current.
Parameter 1-45 q-axis Inductance Sat. (LqSat)	0.000–1000.000 mH	Size related	This parameter corresponds to the inductance saturation of Lq. Ideally, this parameter has the same value as <i>parameter 1-38 q-axis Inductance (Lq)</i> . However, if the motor supplier provides an induction curve, enter the induction value, which is 200% of the nominal current.
Parameter 1-46 Position Detection Gain	20–200%	100%	Adjusts the height of the test pulse during position detection at start.
Parameter 1-48 Current at Min Inductance for d-axis	20–200%	100%	Enter the inductance saturation point.
Parameter 1-49 Current at Min Inductance for q-axis	20–200%	100%	This parameter specifies the saturation curve of the d- and q-inductance values. From 20–100% of this parameter, the inductances are linearly approximated due to <i>parameter 1-37 d-axis Inductance (Ld)</i> , <i>parameter 1-38 q-axis Inductance (Lq)</i> , <i>parameter 1-44 d-axis Inductance Sat. (LdSat)</i> , and <i>parameter 1-45 q-axis Inductance Sat. (LqSat)</i> .
Parameter 1-70 Start Mode	[0] Rotor Detection [1] Parking	[0] Rotor Detection	Select the PM motor start mode.

Parameter	Option	Default	Usage
Parameter 1-73 Flying Start	[0] Disabled [1] Enabled	[0] Disabled	Select [1] Enabled to enable the frequency converter to catch a motor spinning due to mains drop-out. Select [0] Disabled if this function is not required. When this parameter is set to [1] Enabled, parameter 1-71 Start Delay and parameter 1-72 Start Function are not functional. Parameter 1-73 Flying Start is active in VVC <sup>+</sup> mode only.
Parameter 3-02 Minimum Reference	-4999.000–4999.000	0	The minimum reference is the lowest value obtainable by summing all references.
Parameter 3-03 Maximum Reference	-4999.000–4999.000	50	The maximum reference is the highest value obtainable by summing all references.
Parameter 3-41 Ramp 1 Ramp Up Time	0.05–3600.00 s	Size related	If asynchronous motor is selected, the ramp-up time is from 0 to rated parameter 1-23 Motor Frequency. If PM motor is selected, the ramp-up time is from 0 to parameter 1-25 Motor Nominal Speed.
Parameter 3-42 Ramp 1 Ramp Down Time	0.05–3600.00 s	Size related	For asynchronous motors, the ramp-down time is from rated parameter 1-23 Motor Frequency to 0. For PM motors, the ramp-down time is from parameter 1-25 Motor Nominal Speed to 0.
Parameter 4-12 Motor Speed Low Limit [Hz]	0.0–400.0 Hz	0 Hz	Enter the minimum limit for low speed.
Parameter 4-14 Motor Speed High Limit [Hz]	0.0–400.0 Hz	100 Hz	Enter the maximum limit for high speed.
Parameter 4-19 Max Output Frequency	0.0–400.0 Hz	100 Hz	Enter the maximum output frequency value. If parameter 4-19 Max Output Frequency is set lower than parameter 4-14 Motor Speed High Limit [Hz], parameter 4-14 Motor Speed High Limit [Hz] is set equal to parameter 4-19 Max Output Frequency automatically.
Parameter 5-40 Function Relay	See parameter 5-40 Function Relay.	[9] Alarm	Select the function to control output relay 1.
Parameter 5-40 Function Relay	See parameter 5-40 Function Relay.	[5] Drive running	Select the function to control output relay 2.
Parameter 6-10 Terminal 53 Low Voltage	0.00–10.00 V	0.07 V	Enter the voltage that corresponds to the low reference value.
Parameter 6-11 Terminal 53 High Voltage	0.00–10.00 V	10 V	Enter the voltage that corresponds to the high reference value.
Parameter 6-12 Terminal 53 Low Current	0.00–20.00 mA	4 mA	Enter the current that corresponds to the low reference value.
Parameter 6-13 Terminal 53 High Current	0.00–20.00 mA	20 mA	Enter the current that corresponds to the high reference value.
Parameter 6-19 Terminal 53 mode	[0] Current [1] Voltage	[1] Voltage	Select if terminal 53 is used for current or voltage input.
Parameter 30-22 Locked Rotor Protection	[0] Off [1] On	[0] Off	–
Parameter 30-23 Locked Rotor Detection Time [s]	0.05–1 s	0.10 s	–

**Table 2.4 Set-up Wizard for Open-loop Applications**

Set-up Wizard for Closed-loop Applications

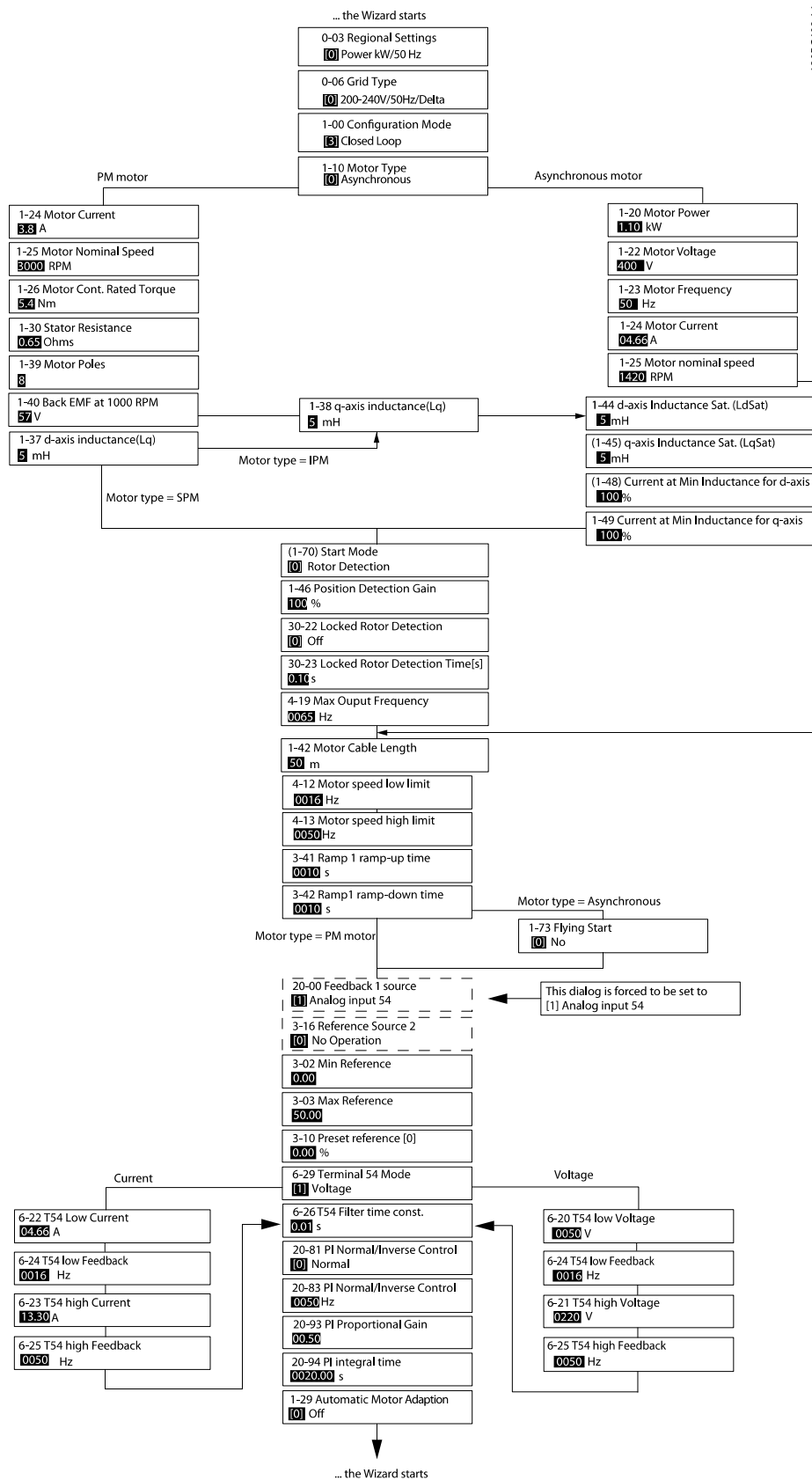

Illustration 2.5 Set-up Wizard for Closed-loop Applications



<b>Parameter</b>	<b>Range</b>	<b>Default</b>	<b>Usage</b>
<i>Parameter 0-03 Regional Settings</i>	<i>[0] International [1] US</i>	<i>[0] International</i>	–
<i>Parameter 0-06 GridType</i>	<i>[0]–[132] see Table 2.4.</i>	<i>Size selected</i>	Select the operating mode for restart after reconnection of the frequency converter to mains voltage after power-down.
<i>Parameter 1-00 Configuration Mode</i>	<i>[0] Open loop [3] Closed loop</i>	<i>[0] Open loop</i>	Select <i>[3] Closed loop</i> .

Parameter	Range	Default	Usage
Parameter 1-10 Motor Construction	*[0] Asynchron [1] PM, non-salient SPM [3] PM, salient IPM	[0] Asynchron	<p>Setting the parameter value might change these parameters:</p> <ul style="list-style-type: none"> <li>• Parameter 1-01 Motor Control Principle.</li> <li>• Parameter 1-03 Torque Characteristics.</li> <li>• Parameter 1-08 Motor Control Bandwidth.</li> <li>• Parameter 1-14 Damping Gain.</li> <li>• Parameter 1-15 Low Speed Filter Time Const.</li> <li>• Parameter 1-16 High Speed Filter Time Const.</li> <li>• Parameter 1-17 Voltage filter time const.</li> <li>• Parameter 1-20 Motor Power.</li> <li>• Parameter 1-22 Motor Voltage.</li> <li>• Parameter 1-23 Motor Frequency.</li> <li>• Parameter 1-24 Motor Current.</li> <li>• Parameter 1-25 Motor Nominal Speed.</li> <li>• Parameter 1-26 Motor Cont. Rated Torque.</li> <li>• Parameter 1-30 Stator Resistance (Rs).</li> <li>• Parameter 1-33 Stator Leakage Reactance (X1).</li> <li>• Parameter 1-35 Main Reactance (Xh).</li> <li>• Parameter 1-37 d-axis Inductance (Ld).</li> <li>• Parameter 1-38 q-axis Inductance (Lq).</li> <li>• Parameter 1-39 Motor Poles.</li> <li>• Parameter 1-40 Back EMF at 1000 RPM.</li> <li>• Parameter 1-44 d-axis Inductance Sat. (LdSat).</li> <li>• Parameter 1-45 q-axis Inductance Sat. (LqSat).</li> <li>• Parameter 1-46 Position Detection Gain.</li> <li>• Parameter 1-48 Current at Min Inductance for d-axis.</li> <li>• Parameter 1-49 Current at Min Inductance for q-axis.</li> <li>• Parameter 1-66 Min. Current at Low Speed.</li> <li>• Parameter 1-70 Start Mode.</li> <li>• Parameter 1-72 Start Function.</li> <li>• Parameter 1-73 Flying Start.</li> <li>• Parameter 1-80 Function at Stop.</li> <li>• Parameter 1-82 Min Speed for Function at Stop [Hz].</li> <li>• Parameter 1-90 Motor Thermal Protection.</li> <li>• Parameter 2-00 DC Hold/Motor Preheat Current.</li> <li>• Parameter 2-01 DC Brake Current.</li> <li>• Parameter 2-02 DC Braking Time.</li> <li>• Parameter 2-04 DC Brake Cut In Speed.</li> <li>• Parameter 2-10 Brake Function.</li> <li>• Parameter 4-14 Motor Speed High Limit [Hz].</li> <li>• Parameter 4-19 Max Output Frequency.</li> <li>• Parameter 4-58 Missing Motor Phase Function.</li> <li>• Parameter 14-65 Speed Derate Dead Time Compensation.</li> </ul>

Parameter	Range	Default	Usage
Parameter 1-20 Motor Power	0.09–110 kW	Size related	Enter the motor power from the nameplate data.
Parameter 1-22 Motor Voltage	50–1000 V	Size related	Enter the motor voltage from the nameplate data.
Parameter 1-23 Motor Frequency	20–400 Hz	Size related	Enter the motor frequency from the nameplate data.
Parameter 1-24 Motor Current	0–10000 A	Size related	Enter the motor current from the nameplate data.
Parameter 1-25 Motor Nominal Speed	50–9999 RPM	Size related	Enter the motor nominal speed from the nameplate data.
Parameter 1-26 Motor Cont. Rated Torque	0.1–1000.0 Nm	Size related	This parameter is available when <i>parameter 1-10 Motor Construction</i> is set to options that enable permanent magnet motor mode. <b>NOTICE</b> Changing this parameter affects the settings of other parameters.
Parameter 1-29 Automatic Motor Adaption (AMA)		Off	Performing an AMA optimizes motor performance.
Parameter 1-30 Stator Resistance (Rs)	0–99,990 Ω	Size related	Set the stator resistance value.
Parameter 1-37 d-axis Inductance (Ld)	0.000–1000.000 mH	Size related	Enter the value of the d-axis inductance. Obtain the value from the permanent magnet motor datasheet.
Parameter 1-38 q-axis Inductance (Lq)	0.000–1000.000 mH	Size related	Enter the value of the q-axis inductance.
Parameter 1-39 Motor Poles	2–100	4	Enter the number of motor poles.
Parameter 1-40 Back EMF at 1000 RPM	10–9000 V	Size related	Line-line RMS back EMF voltage at 1000 RPM.
Parameter 1-42 Motor Cable Length	0–100 m	50 m	Enter the motor cable length.
Parameter 1-44 d-axis Inductance Sat. (LdSat)	0.000–1000.000 mH	Size related	This parameter corresponds to the inductance saturation of Ld. Ideally, this parameter has the same value as <i>parameter 1-37 d-axis Inductance (Ld)</i> . However, if the motor supplier provides an induction curve, enter the induction value, which is 200% of the nominal current.
Parameter 1-45 q-axis Inductance Sat. (LqSat)	0.000–1000.000 mH	Size related	This parameter corresponds to the inductance saturation of Lq. Ideally, this parameter has the same value as <i>parameter 1-38 q-axis Inductance (Lq)</i> . However, if the motor supplier provides an induction curve, enter the induction value, which is 200% of the nominal current.
Parameter 1-46 Position Detection Gain	20–200%	100%	Adjusts the height of the test pulse during position detection at start.
Parameter 1-48 Current at Min Inductance for d-axis	20–200%	100%	Enter the inductance saturation point.
Parameter 1-49 Current at Min Inductance for q-axis	20–200%	100%	This parameter specifies the saturation curve of the d- and q-inductance values. From 20–100% of this parameter, the inductances are linearly approximated due to <i>parameter 1-37 d-axis Inductance (Ld)</i> , <i>parameter 1-38 q-axis Inductance (Lq)</i> , <i>parameter 1-44 d-axis Inductance Sat. (LdSat)</i> , and <i>parameter 1-45 q-axis Inductance Sat. (LqSat)</i> .
Parameter 1-70 Start Mode	[0] Rotor Detection [1] Parking	[0] Rotor Detection	Select the PM motor start mode.
Parameter 1-73 Flying Start	[0] Disabled [1] Enabled	[0] Disabled	Select [1] Enabled to enable the frequency converter to catch a spinning motor in, for example, fan applications. When PM is selected, this parameter is enabled.

Parameter	Range	Default	Usage
Parameter 3-02 Minimum Reference	-4999.000–4999.000	0	The minimum reference is the lowest value obtainable by summing all references.
Parameter 3-03 Maximum Reference	-4999.000–4999.000	50	The maximum reference is the highest value obtainable by summing all references.
Parameter 3-10 Preset Reference	-100–100%	0	Enter the setpoint.
Parameter 3-41 Ramp 1 Ramp Up Time	0.05–3600.0 s	Size related	Ramp-up time from 0 to rated <i>parameter 1-23 Motor Frequency</i> for asynchronous motors. Ramp-up time from 0 to <i>parameter 1-25 Motor Nominal Speed</i> for PM motors.
Parameter 3-42 Ramp 1 Ramp Down Time	0.05–3600.0 s	Size related	Ramp-down time from rated <i>parameter 1-23 Motor Frequency</i> to 0 for asynchronous motors. Ramp-down time from <i>parameter 1-25 Motor Nominal Speed</i> to 0 for PM motors.
Parameter 4-12 Motor Speed Low Limit [Hz]	0.0–400.0 Hz	0.0 Hz	Enter the minimum limit for low speed.
Parameter 4-14 Motor Speed High Limit [Hz]	0.0–400.0 Hz	100 Hz	Enter the maximum limit for high speed.
Parameter 4-19 Max Output Frequency	0.0–400.0 Hz	100 Hz	Enter the maximum output frequency value. If <i>parameter 4-19 Max Output Frequency</i> is set lower than <i>parameter 4-14 Motor Speed High Limit [Hz]</i> , <i>parameter 4-14 Motor Speed High Limit [Hz]</i> is set equal to <i>parameter 4-19 Max Output Frequency</i> automatically.
Parameter 6-20 Terminal 54 Low Voltage	0.00–10.00 V	0.07 V	Enter the voltage that corresponds to the low reference value.
Parameter 6-21 Terminal 54 High Voltage	0.00–10.00 V	10.00 V	Enter the voltage that corresponds to the high reference value.
Parameter 6-22 Terminal 54 Low Current	0.00–20.00 mA	4.00 mA	Enter the current that corresponds to the low reference value.
Parameter 6-23 Terminal 54 High Current	0.00–20.00 mA	20.00 mA	Enter the current that corresponds to the high reference value.
Parameter 6-24 Terminal 54 Low Ref./Feedb. Value	-4999–4999	0	Enter the feedback value that corresponds to the voltage or current set in <i>parameter 6-20 Terminal 54 Low Voltage/parameter 6-22 Terminal 54 Low Current</i> .
Parameter 6-25 Terminal 54 High Ref./Feedb. Value	-4999–4999	50	Enter the feedback value that corresponds to the voltage or current set in <i>parameter 6-21 Terminal 54 High Voltage/parameter 6-23 Terminal 54 High Current</i> .
Parameter 6-26 Terminal 54 Filter Time Constant	0.00–10.00 s	0.01	Enter the filter time constant.
Parameter 6-29 Terminal 54 mode	[0] Current [1] Voltage	[1] Voltage	Select if terminal 54 is used for current or voltage input.
Parameter 20-81 PI Normal/Inverse Control	[0] Normal [1] Inverse	[0] Normal	Select [0] <i>Normal</i> to set the process control to increase the output speed when the process error is positive. Select [1] <i>Inverse</i> to reduce the output speed.
Parameter 20-83 PI Start Speed [Hz]	0–200 Hz	0 Hz	Enter the motor speed to be attained as a start signal for commencement of PI control.
Parameter 20-93 PI Proportional Gain	0.00–10.00	0.01	Enter the process controller proportional gain. Quick control is obtained at high amplification. However, if amplification is too high, the process may become unstable.
Parameter 20-94 PI Integral Time	0.1–999.0 s	999.0 s	Enter the process controller integral time. Obtain quick control through a short integral time, though if the integral time is too short, the process becomes unstable. An excessively long integral time disables the integral action.
Parameter 30-22 Locked Rotor Protection	[0] Off [1] On	[0] Off	–

Parameter	Range	Default	Usage
Parameter 30-23 Locked Rotor Detection Time [s]	0.05–1.00 s	0.10 s	–

**Table 2.5 Set-up Wizard for Closed-loop Applications**
**Motor set-up**

The motor set-up wizard guides users through the needed motor parameters.

Parameter	Range	Default	Usage
Parameter 0-03 Regional Settings	[0] International [1] US	0	–
Parameter 0-06 GridType	[0]–[132] see Table 2.4.	Size related	Select the operating mode for restart after reconnection of the frequency converter to mains voltage after power-down.

Parameter	Range	Default	Usage
Parameter 1-10 Motor Construction	*[0] Asynchron [1] PM, non-salient SPM [3] PM, salient IPM	[0] Asynchron	<p>Setting the parameter value might change these parameters:</p> <ul style="list-style-type: none"> <li>Parameter 1-01 Motor Control Principle.</li> <li>Parameter 1-03 Torque Characteristics.</li> <li>Parameter 1-08 Motor Control Bandwidth.</li> <li>Parameter 1-14 Damping Gain.</li> <li>Parameter 1-15 Low Speed Filter Time Const.</li> <li>Parameter 1-16 High Speed Filter Time Const.</li> <li>Parameter 1-17 Voltage filter time const.</li> <li>Parameter 1-20 Motor Power.</li> <li>Parameter 1-22 Motor Voltage.</li> <li>Parameter 1-23 Motor Frequency.</li> <li>Parameter 1-24 Motor Current.</li> <li>Parameter 1-25 Motor Nominal Speed.</li> <li>Parameter 1-26 Motor Cont. Rated Torque.</li> <li>Parameter 1-30 Stator Resistance (Rs).</li> <li>Parameter 1-33 Stator Leakage Reactance (X1).</li> <li>Parameter 1-35 Main Reactance (Xh).</li> <li>Parameter 1-37 d-axis Inductance (Ld).</li> <li>Parameter 1-38 q-axis Inductance (Lq).</li> <li>Parameter 1-39 Motor Poles.</li> <li>Parameter 1-40 Back EMF at 1000 RPM.</li> <li>Parameter 1-44 d-axis Inductance Sat. (LdSat).</li> <li>Parameter 1-45 q-axis Inductance Sat. (LqSat).</li> <li>Parameter 1-46 Position Detection Gain.</li> <li>Parameter 1-48 Current at Min Inductance for d-axis.</li> <li>Parameter 1-49 Current at Min Inductance for q-axis.</li> <li>Parameter 1-66 Min. Current at Low Speed.</li> <li>Parameter 1-70 Start Mode.</li> <li>Parameter 1-72 Start Function.</li> <li>Parameter 1-73 Flying Start.</li> <li>Parameter 1-80 Function at Stop.</li> <li>Parameter 1-82 Min Speed for Function at Stop [Hz].</li> <li>Parameter 1-90 Motor Thermal Protection.</li> <li>Parameter 2-00 DC Hold/Motor Preheat Current.</li> <li>Parameter 2-01 DC Brake Current.</li> <li>Parameter 2-02 DC Braking Time.</li> <li>Parameter 2-04 DC Brake Cut In Speed.</li> <li>Parameter 2-10 Brake Function.</li> <li>Parameter 4-14 Motor Speed High Limit [Hz].</li> <li>Parameter 4-19 Max Output Frequency.</li> <li>Parameter 4-58 Missing Motor Phase Function.</li> <li>Parameter 14-65 Speed Derate Dead Time Compensation.</li> </ul>

Parameter	Range	Default	Usage
Parameter 1-20 Motor Power	0.12–110 kW/0.16–150 hp	Size related	Enter the motor power from the nameplate data.
Parameter 1-22 Motor Voltage	50–1000 V	Size related	Enter the motor voltage from the nameplate data.
Parameter 1-23 Motor Frequency	20–400 Hz	Size related	Enter the motor frequency from the nameplate data.
Parameter 1-24 Motor Current	0.01–10000.00 A	Size related	Enter the motor current from the nameplate data.
Parameter 1-25 Motor Nominal Speed	50–9999 RPM	Size related	Enter the motor nominal speed from the nameplate data.
Parameter 1-26 Motor Cont. Rated Torque	0.1–1000.0 Nm	Size related	This parameter is available when <i>parameter 1-10 Motor Construction</i> is set to options that enable permanent magnet motor mode. <b>NOTICE</b> Changing this parameter affects the settings of other parameters.
Parameter 1-30 Stator Resistance (Rs)	0–99.990 Ω	Size related	Set the stator resistance value.
Parameter 1-37 d-axis Inductance (Ld)	0.000–1000.000 mH	Size related	Enter the value of the d-axis inductance. Obtain the value from the permanent magnet motor datasheet.
Parameter 1-38 q-axis Inductance (Lq)	0.000–1000.000 mH	Size related	Enter the value of the q-axis inductance.
Parameter 1-39 Motor Poles	2–100	4	Enter the number of motor poles.
Parameter 1-40 Back EMF at 1000 RPM	10–9000 V	Size related	Line-line RMS back EMF voltage at 1000 RPM.
Parameter 1-42 Motor Cable Length	0–100 m	50 m	Enter the motor cable length.
Parameter 1-44 d-axis Inductance Sat. (LdSat)	0.000–1000.000 mH	Size related	This parameter corresponds to the inductance saturation of Ld. Ideally, this parameter has the same value as <i>parameter 1-37 d-axis Inductance (Ld)</i> . However, if the motor supplier provides an induction curve, enter the induction value, which is 200% of the nominal current.
Parameter 1-45 q-axis Inductance Sat. (LqSat)	0.000–1000.000 mH	Size related	This parameter corresponds to the inductance saturation of Lq. Ideally, this parameter has the same value as <i>parameter 1-38 q-axis Inductance (Lq)</i> . However, if the motor supplier provides an induction curve, enter the induction value, which is 200% of the nominal current.
Parameter 1-46 Position Detection Gain	20–200%	100%	Adjusts the height of the test pulse during position detection at start.
Parameter 1-48 Current at Min Inductance for d-axis	20–200%	100%	Enter the inductance saturation point.
Parameter 1-49 Current at Min Inductance for q-axis	20–200%	100%	This parameter specifies the saturation curve of the d- and q-inductance values. From 20–100% of this parameter, the inductances are linearly approximated due to <i>parameter 1-37 d-axis Inductance (Ld)</i> , <i>parameter 1-38 q-axis Inductance (Lq)</i> , <i>parameter 1-44 d-axis Inductance Sat. (LdSat)</i> , and <i>parameter 1-45 q-axis Inductance Sat. (LqSat)</i> .
Parameter 1-70 Start Mode	[0] Rotor Detection [1] Parking	[0] Rotor Detection	Select the PM motor start mode.
Parameter 1-73 Flying Start	[0] Disabled [1] Enabled	[0] Disabled	Select [1] Enabled to enable the frequency converter to catch a spinning motor.
Parameter 3-41 Ramp 1 Ramp Up Time	0.05–3600.0 s	Size related	Ramp-up time from 0 to rated <i>parameter 1-23 Motor Frequency</i> .
Parameter 3-42 Ramp 1 Ramp Down Time	0.05–3600.0 s	Size related	Ramp-down time from rated <i>parameter 1-23 Motor Frequency</i> to 0.

Parameter	Range	Default	Usage
Parameter 4-12 Motor Speed Low Limit [Hz]	0.0–400.0 Hz	0.0 Hz	Enter the minimum limit for low speed.
Parameter 4-14 Motor Speed High Limit [Hz]	0.0–400.0 Hz	100.0 Hz	Enter the maximum limit for high speed.
Parameter 4-19 Max Output Frequency	0.0–400.0 Hz	100.0 Hz	Enter the maximum output frequency value. If parameter 4-19 Max Output Frequency is set lower than parameter 4-14 Motor Speed High Limit [Hz], parameter 4-14 Motor Speed High Limit [Hz] is set equal to parameter 4-19 Max Output Frequency automatically.
Parameter 30-22 Locked Rotor Protection	[0] Off [1] On	[0] Off	–
Parameter 30-23 Locked Rotor Detection Time [s]	0.05–1.00 s	0.10 s	–

Table 2.6 Motor Set-up Wizard Settings

**Changes made**

The changes made function lists all parameters changed from default settings.

- The list shows only parameters that have been changed in the current edit set-up.
- Parameters that have been reset to default values are not listed.
- The message *Empty* indicates that no parameters have been changed.

**Changing parameter settings**

1. To enter the Quick Menu, press the [Menu] key until the indicator in the display is placed above Quick Menu.
2. Press [▲] [▼] to select the wizard, closed-loop set-up, motor set-up, or changes made.
3. Press [OK].
4. Press [▲] [▼] to browse through the parameters in the Quick Menu.
5. Press [OK] to select a parameter.
6. Press [▲] [▼] to change the value of a parameter setting.
7. Press [OK] to accept the change.
8. Press either [Back] twice to enter Status, or press [Menu] once to enter the Main Menu.

**The main menu accesses all parameters**

1. Press the [Menu] key until the indicator in the display is placed above Main Menu.
2. Press [▲] [▼] to browse through the parameter groups.
3. Press [OK] to select a parameter group.
4. Press [▲] [▼] to browse through the parameters in the specific group.
5. Press [OK] to select the parameter.
6. Press [▲] [▼] to set/change the parameter value.

7. Press [OK] to accept the change.

**2.3.3 Main Menu**

Press [Menu] to access the main menu and program all parameters. The main menu parameters can be accessed readily unless a password has been created via parameter 0-60 Main Menu Password.

For most applications, it is not necessary to access the main menu parameters. The quick menu provides the simplest and quickest access to the typically required parameters.

**2.4 Quick Transfer of Parameter Settings between Multiple Frequency Converters**

When the set-up of a frequency converter is completed, store the data in the keypad or on a PC via Trane Drive Utility (TDU).

**Data transfer from the frequency converter to the Keypad**

1. Go to parameter 0-50 LCP Copy.
2. Press [OK].
3. Select [1] All to LCP.
4. Press [OK].

Connect the Keypad to another frequency converter and copy the parameter settings to this frequency converter as well.

**Data transfer from the Keypad to the frequency converter**

1. Go to parameter 0-50 LCP Copy.
2. Press [OK].
3. Select [2] All from LCP.
4. Press [OK].



## 2.5 Readout and Programming of Indexed Parameters

Select the parameter, press [OK], and press [▲]/[▼] to scroll through the indexed values. To change the parameter value, select the indexed value and press [OK]. Change the value by pressing [▲]/[▼]. Press [OK] to accept the new setting. Press [Cancel] to abort. Press [Back] to leave the parameter.

## 2.6 Initialization to Default Settings

There are 2 ways to initialize the frequency converter to the default settings.

### Recommended initialization

1. Select *parameter 14-22 Operation Mode*.
2. Press [OK].
3. Select [2] *Initialisation* and Press [OK].
4. Power off the frequency converter and wait until the display turns off.
5. Reconnect the mains supply. The frequency converter is now reset, except for the following parameters:
  - *Parameter 1-06 Clockwise Direction*
  - *Parameter 8-30 Protocol*
  - *Parameter 8-31 Address*
  - *Parameter 8-32 Baud Rate*
  - *Parameter 8-33 Parity / Stop Bits*
  - *Parameter 8-35 Minimum Response Delay*
  - *Parameter 8-36 Maximum Response Delay*
  - *Parameter 8-37 Maximum Inter-char delay*
  - *Parameter 8-70 BACnet Device Instance*
  - *Parameter 8-72 MS/TP Max Masters*
  - *Parameter 8-73 MS/TP Max Info Frames*
  - *Parameter 8-74 "I am" Service*
  - *Parameter 8-75 Intialisation Password*
  - *Parameter 15-00 Operating hours to parameter 15-05 Over Volt's*
  - *Parameter 15-03 Power Up's*
  - *Parameter 15-04 Over Temp's*
  - *Parameter 15-05 Over Volt's*
  - *Parameter 15-30 Alarm Log: Error Code*
  - *Parameter group 15-4\* Drive identification*
  - *Parameter 18-10 FireMode Log:Event*

### 2-finger initialization

The other way to initialize the frequency converter to default settings is through 2-finger initialization:

1. Power off the frequency converter.
2. Press [OK] and [Menu].
3. Power up the frequency converter while still pressing the keys for 10 s.
4. The frequency converter is now reset, except for the following parameters:
  - *Parameter 1-06 Clockwise Direction*
  - *Parameter 15-00 Operating hours*
  - *Parameter 15-03 Power Up's*
  - *Parameter 15-04 Over Temp's*
  - *Parameter 15-05 Over Volt's*
  - *Parameter group 15-4\* Drive identification*
  - *Parameter 18-10 FireMode Log:Event*

Initialization of parameters is confirmed by *alarm 80, Drive initialised* in the display after the power cycle.

### 3 Parameters

The \* in parameter numbers indicates a group or subgroup of parameters for which the first 1 or 2 numbers are the same. For example, 0-\*\* indicate the group of parameters that all start with 0. 0-0\* indicates the subgroup of parameters that share the first 2 numbers, which is 0-0.

An asterisk (\*) after an option number indicates the default option. For example, [0]\* English is the default option for parameter 0-01 Language.

#### 3.1 Main Menu - Operation and Display - Group 0

Parameters related to the fundamental functions of the frequency converter, function of the keypad keys, and configuration of the keypad display.

##### 3.1.1 0-0\* Basic Settings

0-01 Language		
Option:	Function:	
		Defines the language to be used in the display.
[0] *	English	
[1]	Deutsch	
[2]	Francais	
[3]	Dansk	
[4]	Spanish	
[5]	Italiano	
[28]	Bras.port	
[255]	Numeric prg.	

0-03 Regional Settings		
Option:	Function:	
		<b>NOTICE</b> This parameter cannot be adjusted while the motor is running.  To meet the needs for different default settings in different parts of the world, parameter 0-03 Regional Settings is implemented in the frequency converter. The selected setting influences the default setting of the motor nominal frequency.
[0] *	International	Sets the default value of parameter 1-23 Motor Frequency to 50 Hz.

0-03 Regional Settings		
Option:	Function:	
[1]	North America	Sets the default value of parameter 1-23 Motor Frequency to 60 Hz.

0-04 Operating State at Power-up		
Select the operating mode after reconnection of the frequency converter to mains voltage after power-down when operating in Hand (local) mode.		
Option:	Function:	
[0] *	Resume	Resumes operation of the frequency converter, maintaining the same local reference and the same start/stop condition (applied by [Hand On]/[Off] on the keypad or local start via a digital input) as before the frequency converter was powered down.
[1]	Forced stop, ref=old	Uses saved reference [1] to stop the frequency converter, but at the same time retains the local speed reference in memory before powering down. After mains voltage is reconnected, and after receiving a start command (pressing [Hand On] key or using the local start command via a digital input), the frequency converter restarts and operates at the retained speed reference.

0-06 GridType		
Option:	Function:	
		Select the grid type of the supply voltage/frequency. <b>NOTICE</b> Not all options are supported in all power sizes.  IT Grid is a supply mains, where there are no connections to ground.  Delta is a supply mains where the secondary part of the transformer is delta connected and 1 phase is connected to ground.
[0]	200-240V/50Hz/IT-grid	
[1]	200-240V/50Hz/Delta	

0-06 GridType		
Option:	Function:	
[2]	200-240V/ 50Hz	
[10]	380-440V/ 50Hz/IT-grid	
[11]	380-440V/ 50Hz/Delta	
[12]	380-440V/ 50Hz	
[20]	440-480V/ 50Hz/IT-grid	
[21]	440-480V/ 50Hz/Delta	
[22]	440-480V/ 50Hz	
[30]	525-600V/ 50Hz/IT-grid	
[31]	525-600V/ 50Hz/Delta	
[32]	525-600V/ 50Hz	
[100]	200-240V/ 60Hz/IT-grid	
[101]	200-240V/ 60Hz/Delta	
[102]	200-240V/ 60Hz	
[110]	380-440V/ 60Hz/IT-grid	
[111]	380-440V/ 60Hz/Delta	
[112]	380-440V/ 60Hz	
[120]	440-480V/ 60Hz/IT-grid	
[121]	440-480V/ 60Hz/Delta	
[122]	440-480V/ 60Hz	
[130]	525-600V/ 60Hz/IT-grid	
[131]	525-600V/ 60Hz/Delta	
[132]	525-600V/ 60Hz	

0-07 Auto DC Braking		
Protective function against overvoltage at coast.		
Option:	Function:	
		<b>NOTICE</b> Can cause PWM when coasted.
[0]	Off	This function is not active.

0-07 Auto DC Braking		
Protective function against overvoltage at coast.		
Option:	Function:	
[1] *	On	This function is active.

### 3.1.2 0-1\* Define and Set-up Operations

A complete set of all parameters controlling the frequency converter is called a set-up. The frequency converter contains 2 set-ups: Set-up 1 and set-up 2. Furthermore, a fixed set of factory settings can be copied into 1 or both set-ups.

Some of the advantages of having more than 1 set-up in the frequency converter are:

- Run the motor in 1 set-up (active set-up) while updating parameters in another set-up (edit set-up).
- Connect the 2 motors (1 at a time) to the frequency converter. Motor data for the 2 motors can be placed in the 2 set-ups.
- Rapidly change settings of the frequency converter and/or the motor while the motor is running. For example, ramp time or preset references via bus or digital inputs.

The active set-up can be set as multi set-up, where the active set-up is selected via input on a digital input terminal and/or via the bus control word.

To copy set-up 1 to set-up 2, or copy set-up 2 to set-up 1, use *parameter 0-51 Set-up Copy*. To avoid conflicting settings of the same parameter within 2 different set-ups, link the set-ups using *parameter 0-12 Link Setups*. Stop the frequency converter before switching between set-ups where parameters marked *not changeable during operation* have different values.

Parameters that are *not changeable during operation* are marked *false* in *chapter 5 Parameter Lists*.

0-10 Active Set-up		
Select the set-up in which the frequency converter operates.		
Option:	Function:	
[1] *	Set-up 1	Set-up 1 is active.
[2]	Set-up 2	Set-up 2 is active.
[9]	Multi Set-up	Used for remote set-up selections via digital inputs and the serial communication port. This set-up uses the settings from <i>parameter 0-12 Link Setups</i> .

0-11 Programming Set-up		
The number of the set-up being edited is shown in the keypad, flashing.		
Option:	Function:	
[1]	Set-up 1	Edit set-up 1.
[2]	Set-up 2	Edit set-up 2.
[9] *	Active Set-up	Edit parameters in the set-up selected via digital I/Os.

0-12 Link Setups		
Option:	Function:	
		If the set-ups are not linked, a change between them is not possible while the motor is running.
[0]	Not linked	When selecting a different set-up for operation, the set-up change does not occur until the motor is coasted.
[20] *	Linked	Copies <i>not changeable during operation</i> parameters from 1 set-up to the other. It is possible to switch set-ups while the motor is running.

### 3.1.3 0-3\* keypad Custom Readout and Display Text

It is possible to customize the display elements for various purposes.

#### Custom readout

The calculated value to be shown is based on settings in *parameter 0-30 Custom Readout Unit*, *parameter 0-31 Custom Readout Min Value* (linear only), *parameter 0-32 Custom Readout Max Value*, *parameter 4-14 Motor Speed High Limit [Hz]*, and actual speed.

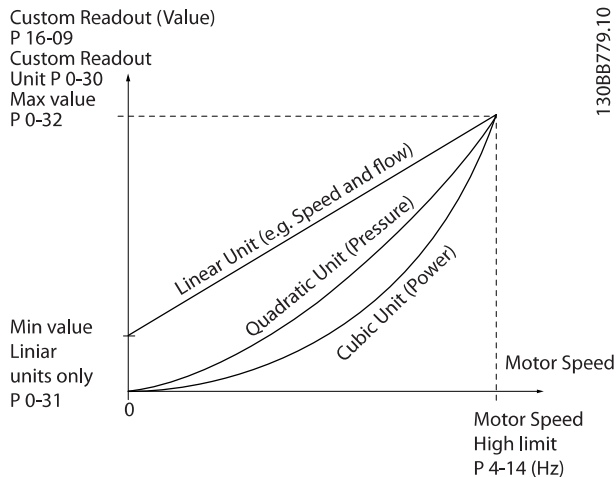

Illustration 3.1 Custom Readout

The relation depends on the type of unit selected in *parameter 0-30 Custom Readout Unit*:

Unit type	Speed relation
Dimensionless	Linear
Speed	
Flow, volume	
Flow, mass	
Velocity	
Length	
Temperature	Quadratic
Pressure	
Power	Cubic

Table 3.1 Speed Relation

0-30 Custom Readout Unit		
Program a value to be shown in the display of the keypad. The value has a linear, squared, or cubed relation to speed. This relation depends on the unit selected (see Table 3.1). The actual calculated value can be read in <i>parameter 16-09 Custom Readout</i> .		
Option:	Function:	
[0]	None	
[1] *	%	
[5]	PPM	
[10]	l/Min	
[11]	RPM	
[12]	Pulse/s	
[20]	l/s	
[21]	l/min	
[22]	l/h	
[23]	m <sup>3</sup> /s	
[24]	m <sup>3</sup> /min	
[25]	m <sup>3</sup> /h	
[30]	kg/s	
[31]	kg/min	
[32]	kg/h	
[33]	t/min	
[34]	t/h	
[40]	m/s	
[41]	m/min	
[45]	m	
[60]	Degree Celsius	
[70]	mbar	
[71]	bar	
[72]	Pa	
[73]	kPa	
[74]	m Wg	
[80]	kW	
[120]	GPM	
[121]	gal/s	
[122]	gal/min	
[123]	gal/h	
[124]	CFM	
[127]	ft <sup>3</sup> /h	

0-30 Custom Readout Unit		
Program a value to be shown in the display of the keypad. The value has a linear, squared, or cubed relation to speed. This relation depends on the unit selected (see <i>Table 3.1</i> ). The actual calculated value can be read in <i>parameter 16-09 Custom Readout</i> .		
Option:	Function:	
[140]	ft/s	
[141]	ft/min	
[160]	Degree Fahr	
[170]	psi	
[171]	lb/in2	
[172]	in WG	
[173]	ft WG	
[180]	hp	

0-31 Custom Readout Min Value		
Range:	Function:	
0 Custom-ReadoutUnit*	[ 0 - 999999.99 CustomReadoutUnit]	This parameter sets the minimum value of the custom-defined readout (occurs at 0 speed). It is only possible to select a value different from 0 when selecting a linear unit in <i>parameter 0-30 Custom Readout Unit</i> . For quadratic and cubic units, the minimum value is 0.

0-32 Custom Readout Max Value		
Range:	Function:	
100 Custom-ReadoutUnit*	[ 0.0 - 999999.99 CustomReadoutUnit]	This parameter sets the maximum value to be shown when the speed of the motor has reached the set value for <i>parameter 4-14 Motor Speed High Limit [Hz]</i> .

0-37 Display Text 1		
Range:	Function:	
	[0 - 0 ]	Use this parameter to write an individual text string to be read via serial communication. Device ID can be included. Only used when running BACnet.

0-38 Display Text 2		
Range:	Function:	
	[0 - 0 ]	Use this parameter to write an individual text string to be read via serial communication. Only used when running BACnet.

0-39 Display Text 3		
Range:	Function:	
	[0 - 0 ]	Use this parameter to write an individual text string to be read via serial communication.

0-39 Display Text 3		
Range:	Function:	
		Only used when running BACnet.

### 3.1.4 0-4\* Keypad

Enable, disable, and password protect individual keys on the keypad.

0-40 [Hand on] Key on LCP		
Option:	Function:	
[0]	Disabled	To avoid unintended start of the frequency converter in <i>hand-on mode</i> , select [0] Disabled.
[1] *	Enabled	[Hand On] is enabled.

0-42 [Auto on] Key on LCP		
Option:	Function:	
[0]	Disabled	To avoid unintended start of the frequency converter from the keypad, select [0] Disabled.
[1] *	Enabled	[Auto On] is enabled.

0-44 [Off/Reset] Key on LCP		
Option:	Function:	
[0]	Disabled	Disable the off/reset key.
[1] *	Enabled	Enable both off and reset functions.
[7]	Enable Reset Only	Enable the reset function, and disable the off function to avoid unintended stop of the frequency converter.

### 3.1.5 0-5\* Copy/Save

Copy parameter settings between set-ups and to/from the keypad.

0-50 LCP Copy		
Option:	Function:	
[0] *	No copy	
[1]	All to LCP	Copies all parameters in all set-ups from the frequency converter memory to the keypad memory. For service purposes, copy all parameters to the Keypad after commissioning.
[2]	All from LCP	Copies all parameters in all set-ups from the keypad memory to the frequency converter memory.
[3]	Size indep. from LCP	Copies only the parameters that are independent of the motor size. The latter selection can be used to

0-50 LCP Copy		
Option:	Function:	
		program several frequency converters with the same function without disturbing motor data that is already set.
[10]	Delete LCP copy data	Delete copied parameters in keypad. This function requires that Keypad version is greater than or equal to V11.00.

0-51 Set-up Copy		
Option:	Function:	
[0] *	No copy	No function.
[1]	Copy from setup 1	Copy from set-up 1 to set-up 2.
[2]	Copy from setup 2	Copy from set-up 2 to set-up 1.
[9]	Copy from Factory setup	Copy factory setting to programming set-up (selected in <i>parameter 0-11 Programming Set-up</i> ).

### 3.1.6 0-6\* Password

0-60 Main Menu Password		
Range:	Function:	
0*	[0 - 999 ]	Define the password for access to the <i>Main Menu</i> via the [Main Menu] key. Setting the value to 0 disables the password function. This parameter hides after a password is defined.

0-61 Access to Main Menu w/o Password		
Option:	Function:	
[0] *	Full access	Disable the password defined in <i>parameter 0-60 Main Menu Password</i> .
[1]	LCP: Read only	Prevent unauthorized editing of <i>Main Menu</i> parameters.
[2]	LCP: No access	Prevent unauthorized viewing and editing of <i>Main Menu</i> parameters.
[3]	Bus: Read only	
[5]	All: Read only	

## 3.2 Main Menu - Load and Motor - Group 1

Parameters related to the motor nameplate load compensations and application load type.

### 3.2.1 1-0\* General Settings

1-00 Configuration Mode		
Option:	Function:	
		<b>NOTICE</b> This parameter cannot be adjusted while the motor is running.
[0] *	Open Loop	Motor speed is determined by applying a speed reference or by setting the wanted speed when in hand-on mode. Open loop is also used if the frequency converter is part of a closed-loop control system based on an external PI controller providing a speed reference signal as output.
[3]	Process Closed Loop	<b>NOTICE</b> When set for <i>Closed Loop</i> , the commands <i>Reversing</i> and <i>Start Reversing</i> do not reverse the direction of the motor.  A reference from the built-in PI controller determines the motor speed. The built-in PI controller varies the motor speed as of a closed-loop control process (for example, constant pressure or flow). Configure the PI controller in <i>parameter group 20-** Drive Closed Loop</i> .

1-01 Motor Control Principle		
Option:	Function:	
[0]	U/f	<b>NOTICE</b> When running U/f, control slip and load compensations are not included.  Used for parallel-connected motors and/or special motor applications. Set the U/f settings in <i>parameter 1-55 U/f Characteristic - U</i> and <i>parameter 1-56 U/f Characteristic - F</i> .

1-01 Motor Control Principle		
Option:	Function:	
[1] *	VVC+	<p><b>NOTICE</b></p> <p>When <i>parameter 1-10 Motor Construction</i> is set to PM-enabled options, only VVC+ option is available.</p> <p>Normal running mode, including slip and load compensations.</p>

1-03 Torque Characteristics		
Option:	Function:	
[1] *	Variable Torque	For speed control of centrifugal pumps and fans. Also to be used when controlling more than 1 motor from the same frequency converter (for example, multiple condenser fans or cooling tower fans). Provides a voltage that is optimized for a squared torque load characteristic of the motor.
[3]	Auto Energy Optim.	For optimum energy efficient speed control of centrifugal pumps and fans, it provides a voltage that is optimized for a squared torque load characteristic of the motor. In addition, the AEO feature adapts the voltage exactly to the current load situation, thereby reducing energy consumption and audible noise from the motor.

1-06 Clockwise Direction		
Option:	Function:	
		<p><b>NOTICE</b></p> <p>This parameter cannot be adjusted while the motor is running.</p> <p>This parameter defines the term <i>clockwise</i> corresponding to the keypad direction arrow. Used for easy change of direction of shaft rotation without swapping motor wires.</p>
[0] *	Normal	The motor shaft turns in clockwise direction when frequency converter is connected U⇒U; V⇒V; and W⇒W to motor.
[1]	Inverse	The motor shaft turns in counter-clockwise direction when frequency converter is connected U⇒U; V⇒V; and W⇒W to motor.

1-08 Motor Control Bandwidth		
Option:	Function:	
[0]	High	Suitable for highly dynamic response.
[1] *	Medium	Suitable for smooth steady-state operation.
[2]	Low	Suitable for smooth steady-state operation with lowest dynamic response.
[3]	Adaptive 1	Suitable for smooth steady-state operation with extra active damping.
[4]	Adaptive 2	This is an alternative to [3] <i>Adaptive 1</i> , which focuses on low-inductance PM motors.

### 3.2.2 1-10 to 1-13 Motor Selection

#### **NOTICE**

This parameter group cannot be adjusted while the motor is running.

The following parameters are active ('x') depending on the setting of *parameter 1-10 Motor Construction*.

<i>Parameter 1-10 Motor Construction</i>	[0] Asynchron	[1] PM, non-salient SPM	[3] PM, salient IPM, Sat.
<i>Parameter 1-00 Configuration Mode</i>	x	x	x
<i>Parameter 1-03 Torque Characteristics</i>	x		
<i>Parameter 1-06 Clockwise Direction</i>	x	x	x
<i>Parameter 1-08 Motor Control Bandwidth</i>	x	x	x
<i>Parameter 1-14 Damping Gain</i>		x	x
<i>Parameter 1-15 Low Speed Filter Time Const.</i>		x	x
<i>Parameter 1-16 High Speed Filter Time Const.</i>		x	x
<i>Parameter 1-17 Voltage filter time const.</i>		x	x
<i>Parameter 1-20 Motor Power [kW]</i>	x		
<i>Parameter 1-22 Motor Voltage</i>	x		
<i>Parameter 1-23 Motor Frequency</i>	x		
<i>Parameter 1-24 Motor Current</i>	x	x	x
<i>Parameter 1-25 Motor Nominal Speed</i>	x	x	x
<i>Parameter 1-26 Motor Cont. Rated Torque</i>		x	x

Parameter 1-10 Motor Construction	[0] Asynchron	[1] PM, non-salient SPM	[3] PM, salient IPM, Sat.
Parameter 1-29 Automatic Motor Adaption (AMA)	x	x	x
Parameter 1-30 Stator Resistance (Rs)	x	x	x
Parameter 1-33 Stator Leakage Reactance (X1)	x		
Parameter 1-35 Main Reactance (Xh)	x		
Parameter 1-37 d-axis Inductance (Ld)		x	x
Parameter 1-38 q-axis Inductance (Lq)			x
Parameter 1-39 Motor Poles	x	x	x
Parameter 1-40 Back EMF at 1000 RPM		x	x
Parameter 1-42 Motor Cable Length	x	x	x
Parameter 1-43 Motor Cable Length Feet	x	x	x
Parameter 1-44 d-axis Inductance Sat. (LdSat)			x
Parameter 1-45 q-axis Inductance Sat. (LqSat)			x
Parameter 1-46 Position Detection Gain		x	x
Parameter 1-48 Current at Min Inductance for d-axis			x
Parameter 1-49 Current at Min Inductance for q-axis			x
Parameter 1-50 Motor Magnetisation at Zero Speed	x		
Parameter 1-52 Min Speed Normal Magnetising [Hz]	x		
Parameter 1-55 U/f Characteristic - U	x		
Parameter 1-56 U/f Characteristic - F	x		
Parameter 1-62 Slip Compensation	x		
Parameter 1-63 Slip Compensation Time Constant	x		
Parameter 1-64 Resonance Dampening	x		
Parameter 1-65 Resonance Dampening Time Constant	x		
Parameter 1-66 Min. Current at Low Speed		x	x
Parameter 1-70 Start Mode		x	x
Parameter 1-71 Start Delay	x	x	x
parameter 1-72 Start Function	x	x	x
Parameter 1-73 Flying Start	x	x	x
Parameter 1-80 Function at Stop	x	x	x

Parameter 1-10 Motor Construction	[0] Asynchron	[1] PM, non-salient SPM	[3] PM, salient IPM, Sat.
Parameter 1-90 Motor Thermal Protection	x	x	x
parameter 2-00 DC Hold Current	x	x	x
Parameter 2-01 DC Brake Current	x	x	x
Parameter 2-02 DC Braking Time	x	x	x
Parameter 2-04 DC Brake Cut In Speed [Hz]	x	x	x
Parameter 2-06 Parking Current		x	x
Parameter 2-07 Parking Time		x	x
Parameter 2-10 Brake Function	x	x	x
Parameter 2-16 AC brake Max. Current	x		
Parameter 2-17 Over-voltage Control	x	x	x
Parameter 4-10 Motor Speed Direction	x	x	x
Parameter 4-14 Motor Speed High Limit [Hz]	x	x	x
Parameter 4-18 Current Limit	x	x	x
Parameter 4-19 Max Output Frequency	x	x	x
Parameter 4-58 Missing Motor Phase Function	x	x	x
Parameter 14-01 Switching Frequency	x	x	x
Parameter 14-03 Overmodulation	x	x	x
Parameter 14-07 Dead Time Compensation Level	x	x	x
Parameter 14-08 Damping Gain Factor	x	x	x
Parameter 14-09 Dead Time Bias Current Level	x	x	x
Parameter 14-10 Mains Failure	x	x	x
Parameter 14-11 Mains Fault Voltage Level	x	x	x
Parameter 14-12 Function at Mains Imbalance	x	x	x
Parameter 14-27 Action At Inverter Fault	x	x	x
Parameter 14-40 VT Level	x	x	x
Parameter 14-41 AEO Minimum Magnetisation	x	x	x
Parameter 14-44 d-axis current optimization for IPM			x
Parameter 14-50 RFI Filter	x		
Parameter 14-51 DC-Link Voltage Compensation	x	x	x
Parameter 14-55 Output Filter	x	x	x
Parameter 14-64 Dead Time Compensation Zero Current Level	x	x	x



Parameter 1-10 Motor Construction	[0] Asynchron	[1] PM, non-salient SPM	[3] PM, salient IPM, Sat.
Parameter 14-65 Speed Derate Dead Time Compensation	x	x	x
Parameter 30-22 Locked Rotor Protection		x	x
Parameter 30-23 Locked Rotor Detection Time [s]		x	x

Table 3.2 Active Parameters

1-10 Motor Construction		
Option:	Function:	
[0] * Asynchron	For asynchronous motors.	
[1] PM, non-salient SPM	For permanent magnet (PM) motors with surface-mounted (non-salient) magnets. Refer to <i>parameter 1-14 Damping Gain</i> to <i>parameter 1-17 Voltage filter time const.</i> for details about optimizing the motor operation.	
[3] PM, salient IPM, Sat.	For permanent magnet (PM) motors with interior (salient) magnets, with inductance saturation control.	

### 3.2.3 1-14 to 1-17 VVC<sup>+</sup> PM

The default control parameters for VVC<sup>+</sup> PM motor control core are optimized for applications and inertia load in the range of  $50 > J_l/J_m > 5$ .  $J_l$  is load inertia from the application and  $J_m$  is machine inertia.

For low inertia applications ( $J_l/J_m < 5$ ), it is recommended that *parameter 1-17 Voltage filter time const.* is increased with a factor of 5–10. Sometimes, *parameter 14-08 Damping Gain Factor* should also be reduced to improve performance and stability.

For high-inertia applications ( $J_l/J_m > 50$ ), increase *parameter 1-15 Low Speed Filter Time Const.* and *parameter 1-16 High Speed Filter Time Const.* to improve performance and stability.

For high load at low speed (<30% of rated speed), it is recommended that *parameter 1-17 Voltage filter time const.* is increased due to non-linearity in the inverter at low speed.

1-14 Damping Gain		
Range:	Function:	
120 %*	[0 - 250 %]	The parameter stabilizes the PM motor to ensure smooth and stable operation. The value of damping gain controls the dynamic performance of the PM motor. Low damping gain results in high dynamic performance and a high value results in a low dynamic

1-14 Damping Gain		
Range:	Function:	
		performance. The dynamic performance is related to the motor data and load type. If the damping gain is too high or low, the control becomes unstable.

1-15 Low Speed Filter Time Const.		
Range:	Function:	
Size related*	[0.01 - 20 s]	High-pass filter damping time constant determines the response time to load steps. Obtain quick control through a short damping time constant. However, if this value is too short, the control becomes unstable. This time constant is used below 10% rated speed.

1-16 High Speed Filter Time Const.		
Range:	Function:	
Size related*	[0.01 - 20 s]	High-pass filter damping time constant determines the response time to load steps. Obtain quick control through a short damping time constant. However, if this value is too short, the control becomes unstable. This time constant is used above 10% rated speed.

1-17 Voltage filter time const.		
Range:	Function:	
Size related*	[0.001 - 1 s]	Machine supply voltage filter time constant is used for reducing the influence of high frequency ripples and system resonances in the calculation of machine supply voltage. Without this filter, the ripples in the currents can distort the calculated voltage and affect the stability of the system.

### 3.2.4 1-2\* Motor Data I

This parameter group comprises input data from the nameplate on the connected motor.

**NOTICE**

These parameters cannot be adjusted while the motor is running.

**NOTICE**

Changing the value of these parameters affects the setting of other parameters.

1-20 Motor Power		
Enter the nominal motor power in kW/hp according to the motor nameplate data. The default value corresponds to the nominal rated output of the unit.		
This parameter cannot be adjusted while the motor is running.		
Option:	Function:	
[2]	0.12 kW - 0.16 hp	
[3]	0.18 kW - 0.25 hp	
[4]	0.25 kW - 0.33 hp	
[5]	0.37 kW - 0.5 hp	
[6]	0.55 kW - 0.75 hp	
[7]	0.75 kW - 1 hp	
[8]	1.1 kW - 1.5 hp	
[9]	1.5 kW - 2 hp	
[10]	2.2 kW - 3 hp	
[11]	3 kW - 4 hp	
[12]	3.7 kW - 5 hp	
[13]	4 kW - 5.4 hp	
[14]	5.5 kW - 7.5 hp	
[15]	7.5 kW - 10 hp	
[16]	11 kW - 15 hp	
[17]	15 kW - 20 hp	
[18]	18.5 kW - 25 hp	
[19]	22 kW - 30 hp	
[20]	30 kW - 40 hp	
[21]	37 kW - 50 hp	
[22]	45 kW - 60 hp	
[23]	55 kW - 75 hp	
[24]	75 kW - 100 hp	
[25]	90 kW - 120 hp	

1-20 Motor Power		
Enter the nominal motor power in kW/hp according to the motor nameplate data. The default value corresponds to the nominal rated output of the unit.		
This parameter cannot be adjusted while the motor is running.		
Option:	Function:	
[26]	110 kW - 150 hp	

1-22 Motor Voltage		
Range:	Function:	
Size related*	[50 - 1000 V]	Enter the nominal motor voltage according to the motor nameplate data. The default value corresponds to the nominal rated output of the unit.

1-23 Motor Frequency		
Range:	Function:	
Size related*	[20 - 400 Hz]	Select the motor frequency value from the motor nameplate data. For 87 Hz operation with 230/400 V motors, set the nameplate data for 230 V/50 Hz. Adapt <i>parameter 4-14 Motor Speed High Limit [Hz]</i> and <i>parameter 3-03 Maximum Reference</i> to the 87 Hz application.

1-24 Motor Current		
Range:	Function:	
Size related*	[0.01 - 1000.00 A]	Enter the nominal motor current value from the motor nameplate data. This data is used for calculating motor torque, motor thermal protection, and so on.

1-25 Motor Nominal Speed		
Range:	Function:	
Size related*	[50 - 60000 RPM]	Enter the nominal motor speed value from the motor nameplate data. This data is used for calculating automatic motor compensations.

1-26 Motor Cont. Rated Torque		
Range:	Function:	
Size related*	[0.1 - 100000.0 Nm]	<b>NOTICE</b> Changing this parameter affects settings of other parameters.  This parameter is available only when <i>parameter 1-10 Motor</i>

1-26 Motor Cont. Rated Torque		
Range:	Function:	
		<i>Construction</i> is set to options that enable permanent motor mode.
1-29 Automatic Motor Adaption (AMA)		
Option:	Function:	
		<p><b>NOTICE</b></p> <p>This parameter cannot be adjusted while the motor is running.</p> <p>The AMA function optimizes dynamic motor performance by automatically optimizing the advanced motor parameters while the motor is stationary.</p>
[0] *	Off	No function
[1]	Enable Complete AMA	<p>When <i>parameter 1-10 Motor Construction</i> is set to [0] <i>Asynchron</i>, perform AMA of <i>parameter 1-30 Stator Resistance (Rs)</i>, <i>parameter 1-33 Stator Leakage Reactance (X1)</i>, and <i>parameter 1-35 Main Reactance (Xh)</i>.</p> <p>When <i>parameter 1-10 Motor Construction</i> is set to options that enable permanent motors, perform AMA of <i>parameter 1-30 Stator Resistance (Rs)</i>, and <i>parameter 1-37 d-axis Inductance (Ld)</i>.</p> <p><b>NOTICE</b></p> <p>Terminal 27 Digital Input (<i>parameter 5-12 Terminal 27 Digital Input</i>) has coast inverse as the default setting. This means that AMA cannot be performed if there is no 24 V to terminal 27.</p>
[2]	Enable Reduced AMA	Performs a reduced AMA of the stator resistance $R_s$ in the system only. Select this option if an LC filter is used between the frequency converter and the motor.

**NOTICE**

When *parameter 1-10 Motor Construction* is set to options that enable permanent motor mode, the only option available is [1] *Enable Complete AMA*.

Activate the AMA function by pressing [Hand On] after selecting [1] *Enable Complete AMA* or [2] *Enable Reduced AMA*. After a normal sequence, the display reads: *Press [OK] to finish AMA*. After pressing [OK], the frequency converter is ready for operation.

**NOTICE**

- For the best adaptation of the frequency converter, run AMA on a cold motor.
- AMA cannot be performed while the motor is running.
- AMA cannot be performed on a motor with a bigger power rating than the frequency converter, for example, when a 5.5 kW (7.4 hp) motor is connected to a 4 kW (5.4 hp) frequency converter.

**NOTICE**

Avoid generating external torque during AMA.

**NOTICE**

If one of the settings in *parameter group 1-2\* Motor Data* is changed, the advanced motor parameters, *parameter 1-30 Stator Resistance (Rs)* to *parameter 1-39 Motor Poles*, return to default setting.

**NOTICE**

Perform a full AMA without filter only, while reduced AMA should be run with a filter.

### 3.2.5 1-3\* Motor Data II

This parameter group comprises input data from the nameplate on the connected motor.

**NOTICE**

These parameters cannot be adjusted while the motor is running.

1-30 Stator Resistance (Rs)		
Range:	Function:	
Size related*	[ 0.0 - 9999.000 Ohm]	Set the stator resistance value. Enter the value from a motor datasheet or perform an AMA on a cold motor.

1-33 Stator Leakage Reactance (X1)		
Range:	Function:	
Size related*	[ 0.0 - 9999.000 Ohm]	Set stator leakage reactance of motor.

1-35 Main Reactance (Xh)		
Range:		Function:
Size related*	[ 0.0 - 9999.00 Ohm]	Set the main reactance of the motor using 1 of these methods: <ul style="list-style-type: none"> <li>Run an AMA on a cold motor. The frequency converter measures the value from the motor.</li> <li>Enter the <math>X_h</math> value manually. Obtain the value from the motor supplier.</li> <li>Use the <math>X_h</math> default setting. The frequency converter establishes the setting based on the motor nameplate data.</li> </ul>

1-37 d-axis Inductance (Ld)		
Range:		Function:
Size related*	[ 0 - 65535 mH]	Obtain the value from the permanent magnet motor datasheet.

1-38 q-axis Inductance (Lq)		
Range:		Function:
Size related*	[ 0.000 - 65535 mH]	Set the value of the q-axis inductance. Obtain the value from the permanent magnet motor datasheet. The value cannot be changed when the motor is running.

1-39 Motor Poles		
Range:		Function:
Size related*	[ 2 - 100 ]	Enter the number of motor poles. The motor pole value is always an even number, because it refers to the total pole number, not pairs of poles.

### 3.2.6 1-4\* Motor Data III

This parameter group comprises input data from the nameplate on the connected motor.

#### **NOTICE**

These parameters cannot be adjusted while the motor is running.

1-40 Back EMF at 1000 RPM		
Range:		Function:
Size related*	[ 1 - 9000 V]	Line-line RMS back EMF voltage at 1000 RPM.

1-42 Motor Cable Length		
Range:		Function:
50 m*	[ 0 - 100 m]	Set the motor cable length during commissioning.

1-43 Motor Cable Length Feet		
Range:		Function:
164 ft*	[ 0 - 328 ft]	Set the motor cable length during commissioning.

1-44 d-axis Inductance Sat. (LdSat)		
Range:		Function:
Size related*	[ 0 - 65535 mH]	This parameter corresponds to the inductance saturation of Ld. Ideally, this parameter has the same value as <i>parameter 1-37 d-axis Inductance (Ld)</i> . However, if the motor supplier provides an induction curve, enter the induction value here, which is 200% of the nominal current.

1-45 q-axis Inductance Sat. (LqSat)		
Range:		Function:
Size related*	[ 0 - 65535 mH]	This parameter corresponds to the inductance saturation of Lq. Ideally, this parameter has the same value as <i>parameter 1-38 q-axis Inductance (Lq)</i> . However, if the motor supplier provides an induction curve, enter the induction value here, which is 200% of the nominal current.

1-46 Position Detection Gain		
Range:		Function:
100 %*	[ 20 - 200 %]	Use this parameter to adjust the height of the test pulse during position detection at start. This parameter is valid from software version 2.80.

1-48 Current at Min Inductance for d-axis		
Range:		Function:
100 %*	[ 20 - 200 %]	Use this parameter to set the inductance saturation point.

1-49 Current at Min Inductance for q-axis		
Range:		Function:
100 %*	[ 20 - 200 %]	This parameter specifies the saturation curve of the q-inductance values. From 20–100% of this parameter, the inductances are linearly approximated due to <i>parameter 1-37 d-axis Inductance (Ld)</i> , <i>parameter 1-38 q-axis</i>

1-49 Current at Min Inductance for q-axis		
Range:	Function:	
		Inductance ( $L_q$ ), parameter 1-44 d-axis Inductance Sat. ( $L_dSat$ ), and parameter 1-45 q-axis Inductance Sat. ( $L_qSat$ ). Below and above they are specified by the corresponding parameters. Parameters are related to the motor nameplate load compensations, the application load type, and the electronic brake function for quick stop/hold of the motor.

### 3.2.7 1-5\* Load Indep. Setting

Parameters for load-independent motor settings.

1-50 Motor Magnetisation at Zero Speed		
Range:	Function:	
100 %*	[0 - 300 %]	Use this parameter along with parameter 1-52 Min Speed Normal Magnetising [Hz] to obtain a different thermal load on the motor when running at low speed. Enter a value that is a percentage of the rated magnetizing current. If the setting is too low, the torque on the motor shaft may be reduced.
		<p><b>Illustration 3.2 Motor Magnetization</b></p>

1-52 Min Speed Normal Magnetising [Hz]		
Range:	Function:	
1 Hz*	[0.1 - 10.0 Hz]	Set the required frequency for normal magnetizing current. Use this parameter along with parameter 1-50 Motor Magnetisation at Zero Speed. See Illustration 3.2.

1-55 U/f Characteristic - U		
Range:	Function:	
Array [6]		
Size related*	[0 - 999 V]	Enter voltage at each frequency point to form a U/f characteristic matching the motor. Frequency

1-55 U/f Characteristic - U		
Range:	Function:	
Array [6]		
		points are defined in parameter 1-56 U/f Characteristic - F.

1-56 U/f Characteristic - F		
Range:	Function:	
Array[6]		
Size related*	[0 - 400.0 Hz]	Enter frequency points to form a U/f characteristic matching the motor. Voltage at each point is defined in parameter 1-55 U/f Characteristic - U.
		Make a U/f characteristic based on 6 definable voltages and frequencies, see Illustration 3.3. Simplify U/f characteristics by merging 2 or more points (voltages and frequencies). Set the points at equal values.
		<p><b>Illustration 3.3 U/f Characteristic</b></p>

### 3.2.8 1-6\* Load Depen. Setting

Parameters for adjusting the load-dependent motor settings.

1-62 Slip Compensation		
Range:	Function:	
Size related*	[-400 - 400 %]	Enter the % value for slip compensation to compensate for tolerances in the value of $n_{M,N}$ . Slip compensation is calculated automatically, which is based on the nominal motor speed $n_{M,N}$ .

1-63 Slip Compensation Time Constant		
Range:	Function:	
0.1 s*	[0.05 - 5 s]	Enter the slip compensation reaction speed. A high value results in slow reaction, and a low value results in quick reaction. If low-frequency resonance problems occur, use a longer time setting.

1-64 Resonance Dampening		
Range:		Function:
100 %*	[0 - 500 %]	Enter the resonance damping value. Set <i>parameter 1-64 Resonance Dampening</i> and <i>parameter 1-65 Resonance Dampening Time Constant</i> to help eliminate high-frequency resonance problems. To reduce resonance oscillation, increase the value of <i>parameter 1-64 Resonance Dampening</i> .

1-65 Resonance Dampening Time Constant		
Range:		Function:
0.005 s*	[0.001 - 0.050 s]	Set <i>parameter 1-64 Resonance Dampening</i> and <i>parameter 1-65 Resonance Dampening Time Constant</i> to help eliminate high-frequency resonance problems. Enter the time constant that provides the best dampening.

1-66 Min. Current at Low Speed		
Range:		Function:
50 %*	[0 - 120 %]	Applies to PM motors only. Increasing the minimum current improves motor torque at low speed, but also reduces efficiency.

### 3.2.9 1-7\* Start Adjustments

Parameters for configuring special motor start features.

1-70 Start Mode		
<p>This parameter is valid since software version 2.80 and later versions. Use this parameter to select the PM motor start mode which is to initialize the VVC<sup>+</sup> control core for previously free-running PM motors. This parameter is active for PM motors in VVC<sup>+</sup> mode only if the motor is stopped (or running at low speed).</p>		
Option:	Function:	
[0]	Rotor Detection	The rotor detection function estimates the electrical angle of the rotor and uses the angle as a starting point. This option is the standard selection for automation frequency converter applications. If the flying start function detects that motor is running at low speed or is stopped, the frequency converter can detect the rotor position (the angle). The frequency converter then starts the motor from that angle.

1-70 Start Mode		
<p>This parameter is valid since software version 2.80 and later versions. Use this parameter to select the PM motor start mode which is to initialize the VVC<sup>+</sup> control core for previously free-running PM motors. This parameter is active for PM motors in VVC<sup>+</sup> mode only if the motor is stopped (or running at low speed).</p>		
Option:	Function:	
[1] *	Parking	The parking function applies DC current across the stator winding and rotates the rotor to electrical zero position. This function is typically selected for HVAC applications. If the flying start function detects that motor is running at low speed or is stopped, the frequency converter sends out a DC current to park the motor at an angle. The frequency converter then starts the motor from that angle.

1-71 Start Delay		
Range:		Function:
0 s*	[0 - 10 s]	This parameter enables a delay of the starting time. The frequency converter begins with the start function selected in <i>parameter 1-72 Start Function</i> . Set the start delay time until acceleration is to begin.

1-72 Start Function		
Option:	Function:	
[0]	DC Hold/delay time	The motor is energized with <i>parameter 2-00 DC Hold/Motor Preheat Current</i> during start delay time.
[2] *	Coast/delay time	The is coasted during start delay time ( off).

1-73 Flying Start		
<p>This function makes it possible to catch a motor that is spinning freely due to a mains drop-out. Flying start searches in clockwise direction only. If not successful, a DC brake is activated. If PM-enabled options are selected, parking is carried out if the speed is below 2.5–5% of nominal speed, in the time set in <i>parameter 2-07 Parking Time</i>.</p> <p>If the speed estimate comes out below 2.5–5% of nominal speed, the parking function is engaged (see <i>parameter 2-06 Parking Current</i> and <i>parameter 2-07 Parking Time</i>). Otherwise, the frequency converter catches the motor at that speed and resumes normal operation.</p> <p>The flying start function used for PM motors is based on an initial speed estimation. The speed is always estimated as the first thing after an active start signal is given.</p> <p>Current limitations of the flying start principle used for PM motors:</p> <ul style="list-style-type: none"> <li>• The speed range is up to 100% nominal speed or the field weakening speed (whichever is lowest).</li> <li>• For high inertia applications (that is, where the load inertia is more than 30 times larger than the motor inertia).</li> </ul>		
<b>Option:</b>	<b>Function:</b>	
[0]	Disabled	
[1]	Enabled	

### 3.2.10 1-8\* Stop Adjustments

Parameters for configuring special motor stop features.

1-80 Function at Stop		
Option:	Function:	
		Select this function after a stop command or after the speed is ramped down to the settings in <i>parameter 1-82 Min Speed for Function at Stop [Hz]</i> .
[0] *	Coast	Leaves the motor in free mode.
[1]	DC hold / Motor Preheat	Energizes the motor with a DC hold current (see <i>parameter 2-00 DC Hold/Motor Preheat Current</i> ).

1-82 Min Speed for Function at Stop [Hz]		
Range:	Function:	
0 Hz*	[0 - 20 Hz]	Set the output frequency at which to activate <i>parameter 1-80 Function at Stop</i> .

1-88 AC Brake Gain		
Range:	Function:	
1.4*	[1.0 - 2.0 ]	This parameter is used to set AC brake power capability (set ramp-down time when inertia is constant). In the condition that the

1-88 AC Brake Gain		
Range:	Function:	
		DC-link voltage is not higher than DC-link voltage warning value, the generator torque can be adjusted with this parameter.

### 3.2.11 1-9\* Motor Temperature

Parameters for configuring the temperature protection features for the motor.

1-90 Motor Thermal Protection		
Option:	Function:	
		Using , the motor temperature is calculated based on frequency, current, and time. Trane recommends using the function, if a thermistor is not present. The functionality is the same for asynchronous motors and PM motors.
[0]	No protection	Disables temperature monitoring.
[1]	Thermistor warning	A thermistor gives a warning if the upper limit of motor temperature range is exceeded.
[2]	Thermistor trip	If the upper limit of motor temperature range is exceeded, a thermistor gives an alarm and makes the frequency converter trip.
[3]	ETR warning 1	If the calculated upper limit of the motor temperature range is exceeded, a warning occurs.
[4] *	ETR trip 1	Start motor thermal calculation based on actual load and time as well as motor frequency only when the motor current is above 110% of the nominal motor current.
[22]	ETR Trip - Extended Detection	Start motor thermal calculation based on actual load and time as well as motor frequency when the motor current is above 110% of the nominal motor current. Another situation is to start motor thermal calculation when the motor current is less than 110% of the nominal motor current and trigger current limit.

1-93 Thermistor Source		
Option:	Function:	
		<p><b>NOTICE</b> This parameter cannot be adjusted while the motor is running.</p> <p>Select the input at which the thermistor (PTC sensor) should be connected. When using an analog input, the same analog cannot be used as a reference in <i>parameter 3-15 Reference Resource 1</i> to <i>parameter 3-17 Reference Resource 3</i>, <i>parameter 20-00 Feedback 1 Source</i>, <i>parameter 20-03 Feedback 2 Source</i>, <i>parameter 24-06 Fire Mode Reference Source</i>, and <i>parameter 24-07 Fire Mode Feedback Source</i>.</p>
[0] *	None	Do not set thermistor source.
[1]	Analog input AI53	Use analog input 53 as thermistor source.
[6]	Digital input 29	Use digital input 29 as thermistor source.

2-01 DC Brake Current		
Range:	Function:	
50 %*	[0 - 150 %]	<p><b>NOTICE</b> <b>MOTOR OVERHEATING</b> The maximum value depends on the rated motor current. To avoid motor damage caused by overheating, do not run at 100% for too long.</p> <p>Set current as % of rated motor current, <i>parameter 1-24 Motor Current</i>. When speed is below the limit set in <i>parameter 2-04 DC Brake Cut In Speed</i>, or when the DC-brake inverse function is active (in <i>parameter group 5-1* Digital Inputs</i> set to [5] DC-brake inverse; or via the serial port), a DC-brake current is applied on a stop command. See <i>parameter 2-02 DC Braking Time</i> for duration.</p>

2-02 DC Braking Time		
Range:	Function:	
10 s*	[0 - 60 s]	Set the duration of the DC brake current set in <i>parameter 2-01 DC Brake Current</i> , once activated.

2-04 DC Brake Cut In Speed		
Range:	Function:	
0 Hz*	[0 - 500 Hz]	This parameter is for setting the DC-brake cut-in speed at which <i>parameter 2-01 DC Brake Current</i> is to be active with a stop command.

2-06 Parking Current		
Range:	Function:	
100 %*	[0 - 150 %]	<p>Set current as percentage of rated motor current, <i>parameter 1-24 Motor Current</i>. Active with <i>parameter 1-73 Flying Start</i>. The parking current is active during the time period set in <i>parameter 2-07 Parking Time</i>.</p> <p><b>NOTICE</b> <i>Parameter 2-06 Parking Current</i> is only active when 1 of the PM motor construction options is selected in <i>parameter 1-10 Motor Construction</i>.</p>

### 3.3 Main Menu - Brakes - Group 2

#### 3.3.1 2-0\* DC Brakes

Parameters for configuring the DC brake and DC hold functions.

2-00 DC Hold/Motor Preheat Current		
Range:	Function:	
50 %*	[0 - 160 %]	<p><b>NOTICE</b> <b>MOTOR OVERHEATING</b> The maximum value depends on the rated motor current. To avoid motor damage caused by overheating, do not run at 100% for too long.</p> <p>Set holding current as a percentage of the rated motor current <math>I_{M,N}</math> in <i>parameter 1-24 Motor Current</i>. <i>Parameter 2-00 DC Hold/Motor Preheat Current</i> holds the motor function (holding torque) or preheats the motor. This parameter is active if DC hold is selected in <i>parameter 1-72 Start Function [0] DC Hold/delay time</i> or <i>parameter 1-80 Function at Stop [1] DC hold/Motor Preheat</i>.</p>



2-07 Parking Time		
Range:		Function:
3 s*	[0.1 - 60 s]	Set the duration of the parking current time set in <i>parameter 2-06 Parking Current</i> . Active with <i>parameter 1-73 Flying Start</i> .
<p><b>NOTICE</b></p> <p><i>Parameter 2-07 Parking Time is only active when options of parameter 1-10 Motor Construction are set to enable PM motors.</i></p>		

### 3.3.2 2-1\* Brake Energy Function

Parameter group for selecting dynamic brake parameters.

2-10 Brake Function		
Option:		Function:
[0] *	Off	The brake resistor is not active.
[2]	AC brake	AC brake is active.

2-16 AC Brake, Max current		
Range:		Function:
100 %*	[0 - 160 %]	Enter the maximum permissible current when using the AC brake to avoid overheating motor windings.

2-17 Over-voltage Control		
Option:		Function:
		Select whether to enable OVC during ramp down, which reduces the risk of frequency converter trip due to overvoltage on the DC link caused by generative power from load.
[0]	Disabled	No OVC required.
[1]	Enabled (not at stop)	Activates OVC when the frequency converter is not in the stop state.
[2] *	Enabled	Activates OVC.
<p><b>NOTICE</b></p> <p>The ramp time is automatically adjusted to avoid tripping of the frequency converter.</p>		

## 3.4 Main Menu–Reference/Ramps–Group 3

### 3.4.1 3-0\* Reference Limits

Parameters for setting the reference unit, limits, and ranges.

Also see *parameter group 20-0\* Feedback* for information on settings in closed loop.

3-02 Minimum Reference		
Range:		Function:
0*	[-4999–4999]	The minimum reference is the lowest value obtainable by summing all references.

3-03 Maximum Reference		
Range:		Function:
Size related*	[-4999.0 - 4999 Reference-FeedbackUnit]	The maximum reference is the highest value obtainable by summing all references. The maximum reference unit matches the selection of configuration in <i>parameter 1-00 Configuration Mode</i> .

### 3.4.2 3-1\* References

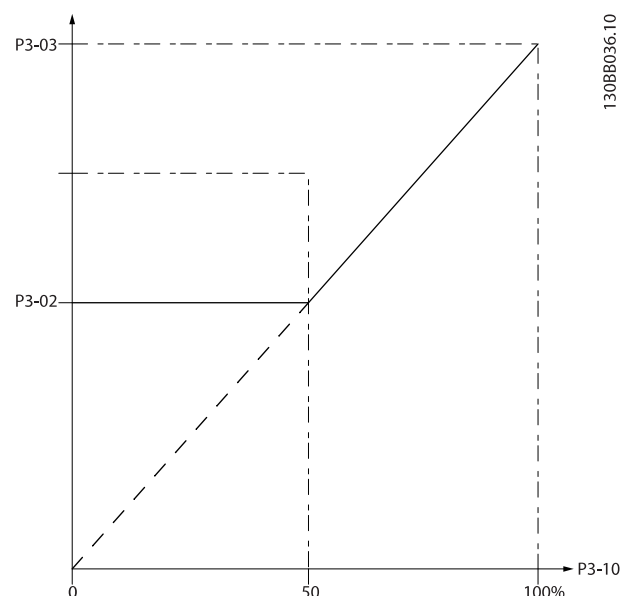

Illustration 3.4 References

3-10 Preset Reference		
Range:		Function:
0 %*	[-100 - 100 %]	Enter up to 8 different preset references (0–7) in this parameter, using array programming. For selecting dedicated references, select <i>preset reference bit 0/1/2 [16]</i> ,

3-10 Preset Reference		
Range:		Function:
		[17], or [18] for the corresponding digital inputs in <i>parameter group 5-1* Digital Inputs</i> .

3-11 Jog Speed [Hz]		
Range:		Function:
5 Hz*	[ 0 - 500.0 Hz]	The jog speed is a fixed output speed at which the frequency converter runs when the jog function is activated. See also <i>parameter 3-80 Jog Ramp Time</i> .

3-14 Preset Relative Reference		
Range:		Function:
0 %*	[-100 - 100 %]	<p>Define the fixed value in % to be added to the variable value defined in <i>parameter 3-18 Relative Scaling Reference Resource</i>.</p> <p>The sum of fixed and variable values (labeled Y in <i>Illustration 3.5</i>) is multiplied by actual reference (labeled X in <i>Illustration 3.5</i>). This product is added to actual reference <math>X + X \times \frac{Y}{100}</math></p> <div style="text-align: center;"> <p>Relative <math>Z = X + X \times Y / 100</math> Resulting actual reference</p> </div> <p><b>Illustration 3.5 Preset Relative Reference</b></p>

3-15 Reference 1 Source		
Select the input to be used for the 1 <sup>st</sup> reference signal. <i>Parameter 3-15 Reference 1 Source, parameter 3-16 Reference 2 Source, and parameter 3-17 Reference 3 Source</i> define up to 3 different reference signals. The sum of these reference signals defines the actual reference.		
Option:	Function:	
[0]	No function	
[1] *	Analog Input 53	
[2]	Analog Input 54	
[7]	Pulse input 29	
[11]	Local bus reference	

3-16 Reference 2 Source		
Select the input to be used for the 2 <sup>nd</sup> reference signal. <i>Parameter 3-15 Reference 1 Source, parameter 3-16 Reference 2 Source, and parameter 3-17 Reference 3 Source</i> define up to 3 different reference signals. The sum of these reference signals defines the actual reference. See also <i>parameter 1-93 Thermistor Source</i> .		
Option:	Function:	
[0]	No function	
[1]	Analog Input 53	
[2] *	Analog Input 54	
[7]	Pulse input 29	
[11]	Local bus reference	

3-17 Reference 3 Source		
Select the reference input to be used for the 3 <sup>rd</sup> reference signal. <i>Parameter 3-15 Reference 1 Source, parameter 3-16 Reference 2 Source, and parameter 3-17 Reference 3 Source</i> define up to 3 different reference signals. The sum of these reference signals defines the actual reference.		
Option:	Function:	
[0]	No function	
[1]	Analog Input 53	
[2]	Analog Input 54	
[7]	Pulse input 29	
[11] *	Local bus reference	

### 3.4.3 3-4\* Ramp 1

Configure the ramp time parameters for each of the 2 ramps (*parameter group 3-4\* Ramp 1 and parameter group 3-5\* Ramp 2*). The ramp time is preset to the minimum value of 10 ms for all power sizes.

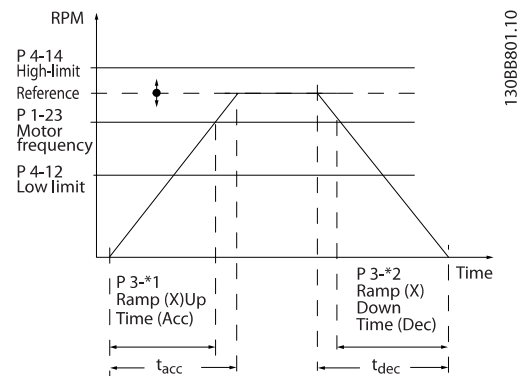

Illustration 3.6 Ramps

3-41 Ramp 1 Ramp Up Time		
Range:		Function:
Size related*	[0.05 - 3600 s]	Enter acceleration time from 0 Hz to <i>parameter 1-23 Motor Frequency</i> if asynchronous motor is selected. Enter acceleration time from 0 RPM, to <i>parameter 1-25 Motor Nominal Speed</i> if PM motor is selected. Select a ramp-up time such that the output current does not exceed the current limit in <i>parameter 4-18 Current Limit</i> during ramping. See ramp-down time in <i>parameter 3-42 Ramp 1 Ramp Down Time</i> .

3-42 Ramp 1 Ramp Down Time		
Range:		Function:
Size related*	[0.05 - 3600 s]	If asynchronous motor is selected, enter deceleration time from <i>parameter 1-23 Motor Frequency</i> to 0 Hz. If PM motor is selected, enter deceleration time from <i>parameter 1-25 Motor Nominal Speed</i> to 0 RPM. Select a ramp-down time to avoid tripping on overvoltage in the DC-link.

### 3.4.4 3-5\* Ramp 2

This parameter group configures ramp 2 parameters.

3-51 Ramp 2 Ramp Up Time		
Range:		Function:
Size related*	[0.05 - 3600 s]	If asynchronous motor is selected, enter acceleration time from 0 Hz to <i>parameter 1-23 Motor Frequency</i> . If PM motor is selected, enter acceleration time from 0 RPM to <i>parameter 1-25 Motor Nominal Speed</i> . Select a ramp-up time such that the output current does not exceed the current limit in <i>parameter 4-18 Current Limit</i> during ramping up.

3-52 Ramp 2 Ramp Down Time		
Range:		Function:
Size related*	[0.05 - 3600 s]	Enter deceleration time from <i>parameter 1-25 Motor Nominal Speed</i> to 0 RPM. Select a ramp-down time such that the output current does not exceed the current limit in <i>parameter 4-18 Current Limit</i> during ramping down.

### 3.4.5 3-8\* Other Ramps

3-80 Jog Ramp Time		
Range:		Function:
Size related*	[0.05 - 3600 s]	Enter the jog ramp time, which is the acceleration/deceleration time between 0 Hz to <i>parameter 1-23 Motor Frequency</i> . Ensure that the resulting output current required for the given jog ramp time does not exceed the current limit in <i>parameter 4-18 Current Limit</i> . The jog ramp time starts after activation of a jog signal via the control panel, a selected digital input, or the serial communication port.

3-81 Quick Stop Ramp Time		
Range:		Function:
Size related*	[0.05 - 3600 s]	Enter the quick stop ramp time from the <i>parameter 1-23 Motor Frequency</i> to 0 Hz. During ramping, no overvoltage may occur in the inverter, nor may the generated current exceed the limit in <i>parameter 4-18 Current Limit</i> . Quick stop is activated with a signal on a selected digital input or via the serial communication port.

## 3.5 Main Menu - Limits/Warnings - Group 4

### 3.5.1 4-1\* Motor Limits

Define current and speed limits for the motor, and the reaction of the frequency converter when the limits are exceeded.

4-10 Motor Speed Direction		
Option:		Function:
[0]	Clockwise	<b>NOTICE</b> The setting in <i>parameter 4-10 Motor Speed Direction</i> has impact on <i>parameter 1-73 Flying Start</i> .  Only operation in clockwise direction is allowed.
[2] *	Both directions	Operation in both clockwise and counterclockwise directions is allowed.

4-12 Motor Speed Low Limit [Hz]		
Range:		Function:
0 Hz*	[ 0 - 400.0 Hz]	Enter the minimum limit for motor speed. The motor speed low limit can be set to correspond to the minimum output frequency of the motor shaft. The speed low limit must not exceed the setting in <i>parameter 4-14 Motor Speed High Limit [Hz]</i> .

4-14 Motor Speed High Limit [Hz]		
Range:		Function:
Size related*	[ 0.1 - 400.0 Hz]	Enter the maximum limit for motor speed. It can be set to match the recommended maximum motor speed. The motor speed high limit must exceed the value in <i>parameter 4-12 Motor Speed Low Limit [Hz]</i> . Motor speed high limit cannot be set higher than <i>parameter 4-19 Max Output Frequency</i> .

4-18 Current Limit		
Range:		Function:
110 %*	[0 - 1000 %]	Enter the current limit for motor and generator operation (in % of rated motor current). If the value is higher than maximum rated output from frequency converter, current is still limited to the maximum output current of the frequency converter. If a setting in <i>parameter 1-00 Configuration Mode</i> to <i>parameter 1-25 Motor Nominal Speed</i> is changed, <i>parameter 4-18 Current Limit</i> is not automatically reset to the default setting.

4-19 Max Output Frequency		
Range:		Function:
Size related*	[ 0 - 400 Hz]	Enter the maximum output frequency, which defines the absolute limit on the frequency converter output frequency for improved safety in applications where unintended overspeeding must be avoided. This absolute limit applies to all configurations and is independent of the setting in <i>parameter 1-00 Configuration Mode</i> . When <i>parameter 1-10 Motor Construction</i> is set to one of the options enabling PM motor

4-19 Max Output Frequency		
Range:		Function:
		construction, the maximum limit of <i>parameter 4-19 Max Output Frequency</i> might be limited by the setting of <i>parameter 1-40 Back EMF at 1000 RPM</i> due to avoid a too high Back EMF, which can damage the frequency converter. If <i>parameter 4-19 Max Output Frequency</i> is set lower than <i>parameter 4-14 Motor Speed High Limit [Hz]</i> , the value of <i>parameter 4-14 Motor Speed High Limit [Hz]</i> is adjusted to the same value of <i>parameter 4-19 Max Output Frequency</i> automatically.

### 3.5.2 4-4\* Adjustable Warnings 2

4-40 Warning Freq. Low		
Range:		Function:
Size related*	[ 0 - 500 Hz]	Use this parameter to set a lower limit for the frequency range. When the motor speed drops below this limit, the display reads <i>SPEED LOW</i> . Warning bit 10 is set in <i>parameter 16-94 Ext. Status Word</i> . The output relay or the digital output can be configured to indicate this warning. The keypad warning indicator light is not turned on when this parameter set limit is reached.

4-41 Warning Freq. High		
Range:		Function:
Size related*	[ 0 - 500 Hz]	Use this parameter to set a higher limit for the frequency range. When the motor speed exceeds this limit, the display reads <i>SPEED HIGH</i> . Warning bit 9 is set in <i>parameter 16-94 Ext. Status Word</i> . The output relay or the digital output can be configured to indicate this warning. The keypad warning indicator light is not turned on when this parameter set limit is reached.

### 3.5.3 4-5\* Adj. Warnings

Define adjustable warning limits for current. Warnings are shown on the display, programmed output, or fieldbus.

4-50 Warning Current Low		
Range:		Function:
0 A	[ 0 - 500 A]	Enter the I <sub>LOW</sub> value. When the motor current drops below this limit, a bit in the status word is set. This value can also be programmed to produce a signal on the digital output or the relay output.

4-51 Warning Current High		
Range:		Function:
Size related*	[ 0.0 - 500.00 A]	Enter the I <sub>HIGH</sub> value. When the motor current exceeds this limit, a bit in the status word is set. This value can also be programmed to produce a signal on the digital output or the relay output.

4-54 Warning Reference Low		
Range:		Function:
-4999*	[-4999 - 4999 ]	Enter the lower reference limit. When the actual reference drops below this limit, the display indicates Ref <sub>Low</sub> . Warning bit 20 is set in <i>parameter 16-94 Ext. Status Word</i> . The output relay or the digital output can be configured to indicate this warning. The keypad warning indicator light is not turned on when this parameter set limit is reached.

4-55 Warning Reference High		
Range:		Function:
4999*	[-4999 - 4999 ]	Use this parameter to set a higher limit for the reference range. When the actual reference exceeds this limit, the display reads <i>Reference High</i> . Warning bit 19 is set in <i>parameter 16-94 Ext. Status Word</i> . The output relay or the digital output can be configured to indicate this warning. The keypad warning indicator light is not turned on when this parameter set limit is reached.

4-56 Warning Feedback Low		
Range:		Function:
-4999 ProcessCtrl Unit*	[-4999 - 4999 ProcessCtrlUnit ]	Use this parameter to set a lower limit for the feedback range. When the feedback drops below this limit, the display reads <i>Feedback Low</i> . Warning bit 6 is set in <i>parameter 16-94 Ext. Status Word</i> .

4-56 Warning Feedback Low		
Range:		Function:
		The output relay or digital output can be configured to indicate this warning. The keypad warning indicator light is not turned on when this parameter set limit is reached.

4-57 Warning Feedback High		
Range:		Function:
4999 ProcessCtrl Unit*	[-4999 - 4999 ProcessCtrlUnit ]	Use this parameter to set a higher limit for the feedback range. When the feedback exceeds this limit, the display reads <i>Feedback High</i> . Warning bit 5 is set in <i>parameter 16-94 Ext. Status Word</i> . The output relay or digital output can be configured to indicate this warning. The keypad warning indicator light is not turned on when this parameter set limit is reached.

4-58 Missing Motor Phase Function		
Option:		Function:
[0]	Off	No alarm is shown if a missing motor phase occurs.
[1] *	On	An alarm is shown if a missing motor phase occurs.

### 3.5.4 4-6\* Speed Bypass

Define the speed bypass areas for the ramps. 3 frequency ranges can be avoided.

4-61 Bypass Speed From [Hz]		
Array[3]		
Range:		Function:
0 Hz	[ 0 - 500 Hz]	Enter the lower limits of the speeds to be avoided. Some systems call for avoiding certain output speeds due to resonance problems in the system.

4-63 Bypass Speed To [Hz]		
Array[3]		
Range:		Function:
0 Hz*	[ 0 - 500 Hz]	Some systems call for avoiding certain output speeds due to resonance problems in the system. Enter the upper limits of the speeds to be avoided.

### 3.5.5 Semi-Automatic Bypass Speed Set-up

Use the semi-automatic bypass speed set-up to facilitate the programming of the frequencies to be skipped due to resonances in the system.

**Procedure:**

1. Stop the motor.

**NOTICE**

Adjust the ramp times in *parameter 3-41 Ramp 1 Ramp Up Time* and *parameter 3-42 Ramp 1 Ramp Down Time*.

2. Select [1] Enabled in *parameter 4-64 Semi-Auto Bypass Set-up*.
3. Press [Hand On] to start the search for frequency bands causing resonances. The motor ramps up according to the ramp set.

**NOTICE**

Terminal 27 digital input *parameter 5-12 Terminal 27 Digital Input* has [2] Coast inverse as default setting. If there is no 24 V to terminal 27, [Hand On] does not start the motor. If so, connect terminal 12 to terminal 27.

4. When sweeping through a resonance band, press [OK] on the keypad when leaving the band. The actual frequency is stored as the first element in *parameter 4-63 Bypass Speed To [Hz]* (array). Repeat this procedure for each resonance band identified at the ramp-up (maximum of 3 can be adjusted).
5. When maximum speed has been reached, the motor automatically begins to ramp down. Repeat this procedure when speed is leaving the resonance bands during the deceleration. The actual frequencies registered when pressing [OK] are stored in *parameter 4-61 Bypass Speed From [Hz]*.
6. When the motor has ramped down to stop, press [OK]. The *parameter 4-64 Semi-Auto Bypass Set-up* automatically resets to off. The frequency converter stays in hand on mode until [Off] or [Auto On] is pressed.

If the frequencies for a certain resonance band are not registered in the right order (frequency values stored in *parameter 4-63 Bypass Speed To [Hz]* are  $\geq$  the values in *parameter 4-61 Bypass Speed From [Hz]*), or if they do not have the same numbers of registrations for the *parameter 4-61 Bypass Speed From [Hz]* and *parameter 4-63 Bypass Speed To [Hz]*, all registrations are canceled and the following message is shown: *Collected speed areas overlapping or not determined. Press [Cancel] to abort.*

4-64 Semi-Auto Bypass Set-up		
Option:	Function:	
[0] *	Off	
[1]	Enable	If this option is selected, speed ranges are automatically swept to identify bands of resonances.

### 3.6 Main Menu - Digital In/Out - Group 5

#### 3.6.1 5-0\* Digital I/O Mode

Parameters for configuring the input and output using NPN and PNP.

**NOTICE**

These parameters cannot be adjusted while the motor is running.

5-00 Digital Input Mode		
Option:	Function:	
		Set NPN or PNP mode for digital inputs 18, 19, and 27. Digital input mode.
[0] *	PNP	Action on positive directional pulses (0). PNP systems are pulled down to ground (GND).
[1]	NPN	Action on negative directional pulses (1). NPN systems are pulled up to +24 V, internally in the frequency converter.

5-03 Digital Input 29 Mode		
Option:	Function:	
[0] *	PNP	Set to PNP mode for digital inputs 29.
[1]	NPN	Set to NPN mode for digital inputs 29.

#### 3.6.2 5-1\* Digital Inputs

Parameters for configuring the input functions for the input terminals.

The digital inputs are used for selecting various functions in the frequency converter. All digital inputs can be set to the following functions:

Digital input function	Description
[0] No operation	No reaction to signals transmitted to the terminal.
[1] Reset	Resets the frequency converter after a trip/alarm. Trip lock alarms can be reset.

Digital input function	Description
[2] <i>Coast inverse</i>	Leaves the motor in free mode. Logic 0→coast stop.
[3] <i>Coast and reset inverse</i>	Reset and coast stop inverted input (NC). Leaves the motor in free mode and resets the frequency converter. Logic 0→coast stop and reset.
[4] <i>Quick stop inverse</i>	Inverted input (NC). Generates a stop in accordance with the quick-stop ramp time set in <i>parameter 3-81 Quick Stop Ramp Time</i> . After ramping down, the shaft is in free mode.
[5] <i>DC brake inverse</i>	Inverted input for DC braking (NC). Stops the motor by energizing it with DC current for a certain time period, see <i>parameter 2-01 DC Brake Current</i> . The function is only active when the value in <i>parameter 2-02 DC Braking Time</i> is different from 0. This selection is not possible when <i>parameter 1-10 Motor Construction</i> is set to [1] <i>PM non-salient SPM</i> .
[6] <i>Stop inverse</i>	The stop inverse function generates the stop function when the selected terminal goes from logical level 1 to 0 (not latched). Stop is performed according to selected ramp time.
[7] <i>External Interlock</i>	Same function as coast stop, inverse, but external interlock generates the alarm message <i>external fault</i> on the display when the terminal programmed for coast inverse is logic 0. If programmed for external interlock, the alarm message is also active via digital outputs and relay outputs. If the cause for the external interlock is removed, the alarm can be reset using a digital input, fieldbus, or the [Reset] key.
[8] <i>Start</i>	Select start for a start/stop command. Logic 1 = start, logic 0 = stop. (Default digital input 18).
[9] <i>Latched start</i>	If a pulse is applied for a minimum of 2 ms, the motor starts. The motor stops when stop inverse is activated.
[10] <i>Reversing</i>	Change direction of motor shaft rotation. The reversing signal only changes the direction of rotation, it does not activate the start function. Select [2] <i>Both directions</i> in <i>parameter 4-10 Motor Speed Direction</i> . 0 = normal, 1 = reversing.
[11] <i>Start reversing</i>	Use for start/stop and for reversing at the same time. Signals on [8] <i>start</i> are not allowed at the same time. 0 = stop, 1 = start reversing.

Digital input function	Description
[14] <i>Jog</i>	Used for activating jog speed. See <i>parameter 3-11 Jog Speed [Hz]</i> . (Default digital input 29).
[16] <i>Preset ref bit 0</i>	Enables a selection of 1 of the 8 preset references according to <i>Table 3.4</i> .
[17] <i>Preset ref bit 1</i>	Enables a selection of 1 of the 8 preset references according to <i>Table 3.4</i> .
[18] <i>Preset ref bit 2</i>	Enables a selection of 1 of the 8 preset references according to <i>Table 3.4</i> .
[19] <i>Freeze reference</i>	Freeze actual reference. The frozen reference is now the point of enable/condition for speed up and speed down to be used. If speed up/speed down is used, a speed change always follows ramp 2 ( <i>parameter 3-51 Ramp 2 Ramp Up Time</i> and <i>parameter 3-52 Ramp 2 Ramp Down Time</i> ) in the range <i>parameter 3-02 Minimum Reference</i> - <i>parameter 3-03 Maximum Reference</i> .
[20] <i>Freeze output</i>	Freezes actual reference. The frozen reference is now the point of enable/condition for speed up and speed down to be used. If speed up/speed down is used, the speed change always follows ramp 2.
[21] <i>Speed up</i>	For digital control of the up/down speed (motor potentiometer). Activate this function by selecting either freeze reference or freeze output. When speed up is activated for less than 400 ms, the resulting reference is increased by 0.1%. If speed up is activated for more than 400 ms, the resulting reference ramps according to ramp 1 in <i>parameter 3-41 Ramp 1 Ramp Up Time</i> .
[22] <i>Speed down</i>	Same as [21] <i>Speed up</i> , but reference decreases.
[23] <i>Set-up select bit 0</i>	Selects 1 of the 2 set-ups. Set <i>parameter 0-10 Active Set-up</i> to multi set-up.
[32] <i>Pulse Input</i>	Select pulse input when using a pulse sequence as either reference or feedback. Scaling is done in <i>parameter group 5-5* Pulse Input</i> . Available only for terminal 29.
[34] <i>Ramp bit 0</i>	Select which ramp to use. Logic 0 selects ramp 1, while logic 1 selects ramp 2.
[37] <i>Fire mode</i>	A signal applied puts the frequency converter into fire mode and disregards all other commands. See <i>parameter group 24-0* Fire Mode</i> .

Digital input function	Description
[52] Run permissive	<p>The input terminal, for which the run permissive is programmed, must be logic 1 before a start command can be accepted. Run permissive has a logic AND function related to the terminal, which is programmed for [8] Start, [14] Jog, or [20] Freeze Output. To start running the motor, both conditions must be fulfilled. If run permissive is programmed on multiple terminals, run permissive only has to be logic 1 on 1 of the terminals for the function to be carried out. Run permissive does not affect the digital output signal for run request ([8] Start, [14] Jog, or [20] Freeze Output) programmed in parameter group 5-3* Digital Outputs, or parameter group 5-4* Relays.</p> <p><b>NOTICE</b> If no run permissive signal is applied but either run, jog, or freeze commands is activated, the status line in the display shows either <i>Run Requested</i>, <i>Jog Requested</i>, or <i>Freeze Requested</i>.</p>
[53] Hand Start	<p>A signal applied puts the frequency converter into hand on mode as if [Hand On] is pressed and a normal stop command is overridden. If the signal is disconnected, the motor stops. To make any other start commands valid, assign another digital input to Auto Start and apply a signal. The [Hand On] and [Auto On] keys have no impact. The [Off] key overrides Hand Start and Auto Start. Press either [Hand On] or [Auto On] to reactivate Hand Start and Auto Start. If there is no signal on Hand Start or Auto Start, the motor stops regardless of any normal start command applied. If a signal is applied to both Hand Start and Auto Start, the function is Auto Start.</p>
[54] Auto start	<p>A signal applied puts the frequency converter into Auto mode as if [Auto On] is pressed. See also [53] Hand Start.</p>
[60] Counter A (up)	Input for increment counting in the SLC counter.
[61] Counter A (down)	Input for decrement counting in the SLC counter.
[62] Reset Counter A	Input for reset of counter A.
[63] Counter B (up)	Input for increment counting in the SLC counter.

Digital input function	Description
[64] Counter B (down)	Input for decrement counting in the SLC counter.
[65] Reset Counter B	Input for reset of counter B.
[101] Sleep	A signal applied puts the frequency converter into sleep mode.

Table 3.3 Digital Input Functions

Selected preset reference:	Preset reference bit 2	Preset reference bit 1	Preset reference bit 0
Preset reference 0	0	0	0
Preset reference 1	0	0	1
Preset reference 2	0	1	0
Preset reference 3	0	1	1
Preset reference 4	1	0	0
Preset reference 5	1	0	1
Preset reference 6	1	1	0
Preset reference 7	1	1	1

Table 3.4 Selected Preset Reference

5-10 Terminal 18 Digital Input		
Parameter for configuring the input function on input terminal 18. Refer to Table 3.3 for setting options.		
Option:	Function:	
[0]	No operation	
[1]	Reset	
[2]	Coast inverse	
[3]	Coast and reset inverse	
[4]	Quick stop inverse	
[5]	DC-brake inverse	
[6]	Stop inverse	
[7]	External Interlock	
[8] *	Start	
[9]	Latched start	
[10]	Reversing	
[11]	Start reversing	
[14]	Jog	
[16]	Preset ref bit 0	



5-10 Terminal 18 Digital Input		
Parameter for configuring the input function on input terminal 18. Refer to <i>Table 3.3</i> for setting options.		
Option:	Function:	
[17]	Preset ref bit 1	
[18]	Preset ref bit 2	
[19]	Freeze reference	
[20]	Freeze output	
[21]	Speed up	
[22]	Speed down	
[23]	Set-up select bit 0	
[34]	Ramp bit 0	
[37]	Fire Mode	
[52]	Run permissive	
[53]	Hand start	
[54]	Auto start	
[60]	Counter A (up)	
[61]	Counter A (down)	
[62]	Reset Counter A	
[63]	Counter B (up)	
[64]	Counter B (down)	
[65]	Reset Counter B	
[101]	Sleep	
[120]	Lead Pump Start	
[121]	Lead Pump Alternation	
[130]	Pump 1 Interlock	
[131]	Pump 2 Interlock	
[132]	Pump 3 Interlock	
[133]	Pump 4 Interlock	
[134]	Pump 5 Interlock	

5-11 Terminal 19 Digital Input		
Parameter for configuring the input function on input terminal 19.		
Option:	Function:	
[0] *	No operation	
[1]	Reset	
[2]	Coast inverse	
[3]	Coast and reset inverse	

5-11 Terminal 19 Digital Input		
Parameter for configuring the input function on input terminal 19.		
Option:	Function:	
[4]	Quick stop inverse	
[5]	DC-brake inverse	
[6]	Stop inverse	
[7]	External Interlock	
[8]	Start	
[9]	Latched start	
[10]	Reversing	
[11]	Start reversing	
[14]	Jog	
[16]	Preset ref bit 0	
[17]	Preset ref bit 1	
[18]	Preset ref bit 2	
[19]	Freeze reference	
[20]	Freeze output	
[21]	Speed up	
[22]	Speed down	
[23]	Set-up select bit 0	
[34]	Ramp bit 0	
[37]	Fire Mode	
[52]	Run permissive	
[53]	Hand start	
[54]	Auto start	
[60]	Counter A (up)	
[61]	Counter A (down)	
[62]	Reset Counter A	
[63]	Counter B (up)	
[64]	Counter B (down)	
[65]	Reset Counter B	
[101]	Sleep	
[120]	Lead Pump Start	
[121]	Lead Pump Alternation	
[130]	Pump 1 Interlock	
[131]	Pump 2 Interlock	
[132]	Pump 3 Interlock	
[133]	Pump 4 Interlock	

5-11 Terminal 19 Digital Input		
Parameter for configuring the input function on input terminal 19.		
<b>Option:</b>		<b>Function:</b>
[134]	Pump 5 Interlock	

5-12 Terminal 27 Digital Input		
Parameter for configuring the input function on input terminal 27. When <i>parameter 0-03 Regional Settings</i> is set to [0] <i>International</i> , the default value is [2] <i>Coast inverse</i> . When <i>parameter 0-03 Regional Settings</i> is set to [1] <i>North America</i> , the default value is [7] <i>External Interlock</i> .		
<b>Option:</b>		<b>Function:</b>
[0]	No operation	
[1]	Reset	
[2]	Coast inverse	
[3]	Coast and reset inverse	
[4]	Quick stop inverse	
[5]	DC-brake inverse	
[6]	Stop inverse	
[7]	External Interlock	
[8]	Start	
[9]	Latched start	
[10]	Reversing	
[11]	Start reversing	
[14]	Jog	
[16]	Preset ref bit 0	
[17]	Preset ref bit 1	
[18]	Preset ref bit 2	
[19]	Freeze reference	
[20]	Freeze output	
[21]	Speed up	
[22]	Speed down	
[23]	Set-up select bit 0	
[34]	Ramp bit 0	
[37]	Fire Mode	
[52]	Run permissive	
[53]	Hand start	
[54]	Auto start	
[60]	Counter A (up)	
[61]	Counter A (down)	
[62]	Reset Counter A	
[63]	Counter B (up)	
[64]	Counter B (down)	

5-12 Terminal 27 Digital Input		
Parameter for configuring the input function on input terminal 27. When <i>parameter 0-03 Regional Settings</i> is set to [0] <i>International</i> , the default value is [2] <i>Coast inverse</i> . When <i>parameter 0-03 Regional Settings</i> is set to [1] <i>North America</i> , the default value is [7] <i>External Interlock</i> .		
<b>Option:</b>		<b>Function:</b>
[65]	Reset Counter B	
[101]	Sleep	
[120]	Lead Pump Start	
[121]	Lead Pump Alternation	
[130]	Pump 1 Interlock	
[131]	Pump 2 Interlock	
[132]	Pump 3 Interlock	
[133]	Pump 4 Interlock	
[134]	Pump 5 Interlock	

5-13 Terminal 29 Digital Input		
Parameter for configuring the input function on input terminal 29.		
<b>Option:</b>		<b>Function:</b>
[0]	No operation	
[1]	Reset	
[2]	Coast inverse	
[3]	Coast and reset inverse	
[4]	Quick stop inverse	
[5]	DC-brake inverse	
[6]	Stop inverse	
[7]	External Interlock	
[8]	Start	
[9]	Latched start	
[10]	Reversing	
[11]	Start reversing	
[14] *	Jog	
[16]	Preset ref bit 0	
[17]	Preset ref bit 1	
[18]	Preset ref bit 2	
[19]	Freeze reference	
[20]	Freeze output	
[21]	Speed up	
[22]	Speed down	

5-13 Terminal 29 Digital Input		
Parameter for configuring the input function on input terminal 29.		
Option:	Function:	
[23]	Set-up select bit 0	
[32]	Pulse input	
[34]	Ramp bit 0	
[37]	Fire Mode	
[52]	Run permissive	
[53]	Hand start	
[54]	Auto start	
[60]	Counter A (up)	
[61]	Counter A (down)	
[62]	Reset Counter A	
[63]	Counter B (up)	
[64]	Counter B (down)	
[65]	Reset Counter B	
[101]	Sleep	
[120]	Lead Pump Start	
[121]	Lead Pump Alternation	
[130]	Pump 1 Interlock	
[131]	Pump 2 Interlock	
[132]	Pump 3 Interlock	
[133]	Pump 4 Interlock	
[134]	Pump 5 Interlock	

5-34 On Delay, Digital Output		
Range:	Function:	
0.01 s*	[0 - 600 s]	Enter the delay time before the digital output is switched on. The digital output (terminal 42/45) condition must not be interrupted during the delay time.

5-35 Off Delay, Digital Output		
Range:	Function:	
0.01 s*	[0 - 600 s]	Enter the delay time before the digital output is switched off. The digital output (terminal 42/45) condition must not be interrupted during the delay time.

### 3.6.3 5-4\* Relays

Parameters for configuring the timing and the output functions for the relays.

5-40 Function Relay		
<b>Array (Relay 1 [0], Relay 2 [1])</b>		
Select options to define the function of the relays.		
The selection of each mechanical relay is realized in an array parameter. When <i>parameter 0-03 Regional Settings</i> is set to [0] <i>International</i> , the default value is [9] <i>Alarm</i> . When <i>parameter 0-03 Regional Settings</i> is set to [1] <i>North America</i> , the default value is [160] <i>No alarm</i> .		
Option:	Function:	
[0]	No operation	
[1]	Control Ready	The control board receives supply voltage.
[2]	Drive ready	The frequency converter is ready for operation and applies a supply signal on the control board.
[3]	Drive ready/ remote control	The frequency converter is ready for operation in auto mode.
[4]	Standby / no warning	The frequency converter is ready for operation. No start or stop command is given. No warnings are present.
[5]	Drive running	The motor runs.
[6]	Running / no warning	The motor runs, and no warnings are present.
[7]	Run in range/no warning	The motor runs within the programmed current ranges, see <i>parameter 4-50 Warning Current Low</i> and <i>parameter 4-51 Warning Current High</i> . No warnings are present.
[8]	Run on ref/no warning	The motor runs at reference speed and with no warnings.
[9]	Alarm	An alarm activates output.
[10]	Alarm or warning	An alarm or warning activates output.
[12]	Out of current range	The motor current is outside the ranges set in <i>parameter 4-50 Warning Current Low</i> and <i>parameter 4-51 Warning Current High</i> .
[13]	Below current, low	The motor current is lower than the limit set in <i>parameter 4-50 Warning Current Low</i> .
[14]	Above current, high	The motor current is higher than the limit set in <i>parameter 4-51 Warning Current High</i> .

5-40 Function Relay		
<b>Array (Relay 1 [0], Relay 2 [1])</b>		
Select options to define the function of the relays.		
The selection of each mechanical relay is realized in an array parameter. When <i>parameter 0-03 Regional Settings</i> is set to [0] <i>International</i> , the default value is [9] <i>Alarm</i> . When <i>parameter 0-03 Regional Settings</i> is set to [1] <i>North America</i> , the default value is [160] <i>No alarm</i> .		
Option:	Function:	
[16]	Below speed, low	The frequency converter output speed is lower than the limit set in <i>parameter 4-40 Warning Freq. Low</i> .
[17]	Above speed, high	The frequency converter output speed is higher than the limit set in <i>parameter 4-41 Warning Freq. High</i> .
[19]	Below feedback, low	The feedback is lower than the limit set in <i>parameter 4-56 Warning Feedback Low</i> .
[20]	Above feedback, high	The feedback is higher than the limit set in <i>parameter 4-57 Warning Feedback High</i> .
[21]	Thermal warning	The thermal warning turns on when the temperature exceeds the limit in motor, frequency converter, or thermistor.
[22]	Ready, no thermal warning	The frequency converter is ready for operation and no thermal warning is present.
[23]	Remote, ready, no thermal warning	The frequency converter is ready for operation in auto mode, and no thermal warning is present.
[24]	Ready, Voltage OK	The frequency converter is ready for operation and mains voltage is within the specified voltage range.
[25]	Reverse	The motor runs/is ready to run clockwise when logic = 0 and counterclockwise when logic = 1. Output changes as soon as reversing signal is applied.
[26]	Bus OK	Active communication (no timeout) via serial communication port.
[35]	External Interlock	See digital input.
[36]	Control word bit 11	Bit 11 in control word controls the relay.
[37]	Control word bit 12	Bit 12 in control word controls the relay.
[41]	Below reference, low	The reference is lower than the limit set in <i>parameter 4-54 Warning Reference Low</i> .

5-40 Function Relay		
<b>Array (Relay 1 [0], Relay 2 [1])</b>		
Select options to define the function of the relays.		
The selection of each mechanical relay is realized in an array parameter. When <i>parameter 0-03 Regional Settings</i> is set to [0] <i>International</i> , the default value is [9] <i>Alarm</i> . When <i>parameter 0-03 Regional Settings</i> is set to [1] <i>North America</i> , the default value is [160] <i>No alarm</i> .		
Option:	Function:	
[42]	Above ref, high	The reference is higher than the limit set in <i>parameter 4-55 Warning Reference High</i> .
[45]	Bus Control	The output is configured in <i>parameter 5-90 Digital &amp; Relay Bus Control</i> .
[60]	Comparator 0	See <i>parameter group 13-1* Comparators</i> . If comparator 0 is evaluated as <i>true</i> , the output goes high. Otherwise, it is low.
[61]	Comparator 1	See <i>parameter group 13-1* Comparators</i> . If comparator 1 is evaluated as <i>true</i> , the output goes high. Otherwise, it is low.
[62]	Comparator 2	See <i>parameter group 13-1* Comparators</i> . If comparator 2 is evaluated as <i>true</i> , the output goes high. Otherwise, it is low.
[63]	Comparator 3	See <i>parameter group 13-1* Comparators</i> . If comparator 3 is evaluated as <i>true</i> , the output goes high. Otherwise, it is low.
[64]	Comparator 4	See <i>parameter group 13-1* Comparators</i> . If comparator 4 is evaluated as <i>true</i> , the output goes high. Otherwise, it is low.
[65]	Comparator 5	See <i>parameter group 13-1* Comparators</i> . If comparator 5 is evaluated as <i>true</i> , the output goes high. Otherwise, it is low.
[70]	Logic rule 0	See <i>parameter group 13-4* Logic Rules</i> . If logic rule 0 is evaluated as <i>true</i> , the output goes high. Otherwise, it is low.
[71]	Logic rule 1	See <i>parameter group 13-4* Logic Rules</i> . If logic rule 1 is evaluated as <i>true</i> , the output goes high. Otherwise, it is low.
[72]	Logic rule 2	See <i>parameter group 13-4* Logic Rules</i> . If logic rule 2 is evaluated as <i>true</i> , the output goes high. Otherwise, it is low.

5-40 Function Relay		
<b>Array (Relay 1 [0], Relay 2 [1])</b>		
Select options to define the function of the relays. The selection of each mechanical relay is realized in an array parameter. When <i>parameter 0-03 Regional Settings</i> is set to [0] <i>International</i> , the default value is [9] <i>Alarm</i> . When <i>parameter 0-03 Regional Settings</i> is set to [1] <i>North America</i> , the default value is [160] <i>No alarm</i> .		
Option:	Function:	
[73]	Logic rule 3	See <i>parameter group 13-4* Logic Rules</i> . If logic rule 3 is evaluated as <i>true</i> , the output goes high. Otherwise, it is low.
[74]	Logic rule 4	See <i>parameter group 13-4* Logic Rules</i> . If logic rule 4 is evaluated as <i>true</i> , the output goes high. Otherwise, it is low.
[75]	Logic rule 5	See <i>parameter group 13-4* Logic Rules</i> . If logic rule 5 is evaluated as <i>true</i> , the output goes high. Otherwise, it is low.
[80]	SL digital output A	See <i>parameter 13-52 SL Controller Action</i> . The input goes high whenever the smart logic action [38] <i>Set dig. out. A high</i> is executed. The input goes low whenever the smart logic [32] <i>Action Set dig. out. A low</i> is executed.
[81]	SL digital output B	See <i>parameter 13-52 SL Controller Action</i> . The input goes high whenever the smart logic action [39] <i>Set dig. out. B high</i> is executed. The input goes low whenever the smart logic [33] <i>Action Set dig. out. B low</i> is executed.
[82]	SL digital output C	See <i>parameter 13-52 SL Controller Action</i> . The input goes high whenever the smart logic action [40] <i>Set dig. out. C high</i> is executed. The input goes low whenever the smart logic [34] <i>Action Set dig. out. C low</i> is executed.
[83]	SL digital output D	See <i>parameter 13-52 SL Controller Action</i> . The input goes high whenever the smart logic [41] <i>Action Set dig. out. D high</i> is executed. The input goes low whenever the smart logic [35] <i>Action Set dig. out. D low</i> is executed.
[160]	No alarm	The output is high when no alarm is present.

5-40 Function Relay		
<b>Array (Relay 1 [0], Relay 2 [1])</b>		
Select options to define the function of the relays. The selection of each mechanical relay is realized in an array parameter. When <i>parameter 0-03 Regional Settings</i> is set to [0] <i>International</i> , the default value is [9] <i>Alarm</i> . When <i>parameter 0-03 Regional Settings</i> is set to [1] <i>North America</i> , the default value is [160] <i>No alarm</i> .		
Option:	Function:	
[161]	Running reverse	The output is high when the frequency converter is running counterclockwise (the logical product of the status bits running and reverse).
[165]	Local ref. active	The output is high when local reference is activated by the [Hand On] key on the keypad or by hand-on command of digital input.
[166]	Remote ref. active	The output is high when remote reference is activated by the [Auto On] key on the keypad or by auto-on command of digital input.
[167]	Start command activ	The output is high when there is an active start command (that is, via digital input bus connection or [Hand On] or [Auto On], and no stop command is active).
[168]	Drive in hand mode	The output is high when the frequency converter is in hand On mode (as indicated by the LED light above [Hand On]).
[169]	Drive in auto mode	The output is high when the frequency converter is in auto On mode (as indicated by the LED light above [Auto On]).
[190]	No-Flow	A no-flow condition has been detected. See <i>parameter group 22-2* No-Flow Detection</i> .
[193]	Sleep Mode	The frequency converter/system has entered sleep mode. See <i>parameter group 22-4* Sleep Mode</i> .
[194]	Broken Belt Function	A broken-belt condition has been detected. Enable the function in <i>parameter 22-60 Broken Belt Function</i> .
[196]	Fire Mode	The frequency converter is operating in fire mode. See <i>parameter group 24-0* Fire Mode</i> .
[198]	Drive Bypass	To be used as a signal for activating an external electromechanical bypass, switching the motor directly on line.

5-40 Function Relay		
<b>Array (Relay 1 [0], Relay 2 [1])</b>		
Select options to define the function of the relays. The selection of each mechanical relay is realized in an array parameter. When <i>parameter 0-03 Regional Settings</i> is set to [0] <i>International</i> , the default value is [9] <i>Alarm</i> . When <i>parameter 0-03 Regional Settings</i> is set to [1] <i>North America</i> , the default value is [160] <i>No alarm</i> .		
<b>Option:</b>	<b>Function:</b>	
	See <i>parameter group 24-1* Drive Bypass</i> .	
[211]	Cascade Pump 1	
[212]	Cascade Pump 2	
[213]	Cascade Pump 3	
[214]	Cascade Pump 4	
[215]	Cascade Pump 5	

5-41 On Delay, Relay		
Array [2]		
<b>Range:</b>	<b>Function:</b>	
0.01 s*	[0.01 - 600 s]	Enter the delay of the relay cut-in time. Select 1 of 2 internal mechanical relays in an array function. See <i>parameter 5-40 Function Relay</i> for details.

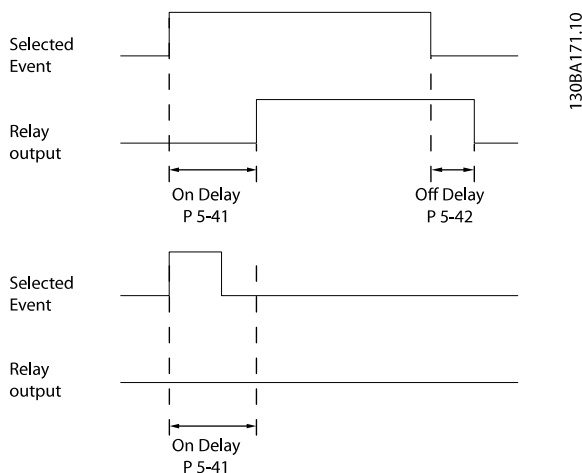

Illustration 3.7 On Delay, Relay

5-42 Off Delay, Relay		
Array[2]		
<b>Range:</b>	<b>Function:</b>	
0.01 s*	[0.01 - 600 s]	Enter the delay of the relay cutout time. Select 1 of 2 internal

5-42 Off Delay, Relay		
Array[2]		
<b>Range:</b>	<b>Function:</b>	
	mechanical relays in an array function. See <i>parameter 5-40 Function Relay</i> for details. If the selected event condition changes before a delay timer expires, the relay output is unaffected.	

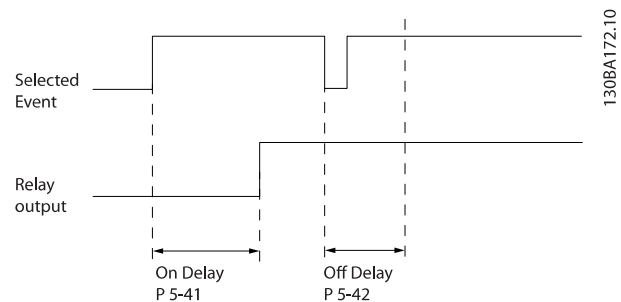

Illustration 3.8 Off Delay, Relay

If the selected event condition changes before the on delay or off delay timer expires, the relay output is unaffected.

### 3.6.4 5-5\* Pulse Input

The pulse input parameters are used to define an appropriate window for the impulse reference area by configuring the scaling and filter settings for the pulse inputs. Input terminals 29 or 33 act as frequency reference inputs. Set terminal 29 (*parameter 5-13 Terminal 29 Digital Input*) or terminal 33 (*parameter 5-15 Terminal 33 Digital Input*) to [32] *Pulse input*. If terminal 29 is used as an input, set *parameter 5-01 Terminal 27 Mode* to [0] *Input*.

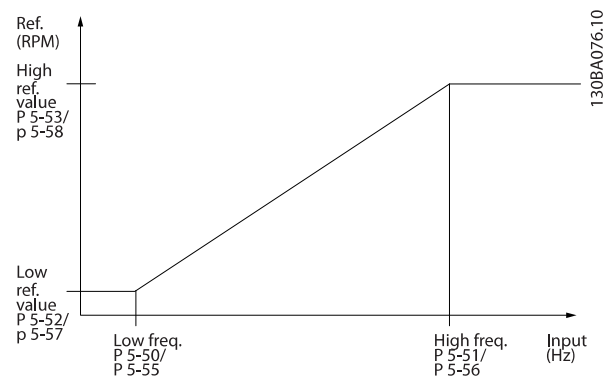

Illustration 3.9 Pulse Input

5-50 Term. 29 Low Frequency		
Range:		Function:
20 Hz*	[20 - 31999 Hz]	Enter the low frequency limit corresponding to the low motor shaft speed (that is low reference value) in <i>parameter 5-52 Term. 29 Low Ref./Feedb. Value</i> . See <i>Illustration 3.9</i> .

5-51 Term. 29 High Frequency		
Range:		Function:
32000 Hz*	[21 - 32000 Hz]	Enter the high frequency limit corresponding to the high motor shaft speed (that is high reference value) in <i>parameter 5-53 Term. 29 High Ref./Feedb. Value</i> .

5-52 Term. 29 Low Ref./Feedb. Value		
Range:		Function:
0*	[-4999 - 4999 ]	Enter the low reference value limit for the motor shaft speed [RPM]. This is also the lowest feedback value. Set terminal 29 to digital input ( <i>parameter 5-13 Terminal 29 Digital Input = applicable value</i> ).

5-53 Term. 29 High Ref./Feedb. Value		
Range:		Function:
Size related*	[-4999 - 4999 ]	Enter the high reference value [RPM] for the motor shaft speed and the high feedback value. Select terminal 29 as a digital input ( <i>parameter 5-13 Terminal 29 Digital Input = applicable value</i> ).

### 3.6.5 5-9\* Bus Controlled

This parameter group selects digital and relay outputs via a fieldbus setting.

5-90 Digital & Relay Bus Control		
Range:		Function:
0*	[0 - 0xFFFFFFFF ]	This parameter holds the state of the bus-controlled digital outputs and relays. A logical 1 indicates that the output is high or active. A logical 0 indicates that the output is low or inactive.

Bit 0-3	Reserved
Bit 4	Relay 1 output terminal
Bit 6-23	Reserved
Bit 24	Terminal 42 digital output
Bit 26-31	Reserved

Table 3.5 Bit Functions

### 3.7 Main Menu - Analog In/Out - Group 6

Parameter group for setting up the analog I/O configuration and the digital output.

The frequency converter provides 2 analog inputs:

- Terminal 53.
- Terminal 54.

The analog inputs can be freely allocated to either voltage (0-10 V) or current input (0/4-20 mA).

#### 3.7.1 6-0\* Analog I/O Mode

6-00 Live Zero Timeout Time		
Range:		Function:
10 s*	[1 - 99 s]	Enter the timeout time.

6-01 Live Zero Timeout Function		
Select the timeout function. The function set in <i>parameter 6-01 Live Zero Timeout Function</i> is activated if the input signal on terminal 53 or 54 is below 50% of the value in <i>parameter 6-10 Terminal 53 Low Voltage</i> , <i>parameter 6-12 Terminal 53 Low Current</i> , <i>parameter 6-20 Terminal 54 Low Voltage</i> , or <i>parameter 6-22 Terminal 54 Low Current</i> for a time period defined in <i>parameter 6-00 Live Zero Timeout Time</i> .		
Option:	Function:	
[0] *	Off	
[1]	Freeze output	
[2]	Stop	
[3]	Jogging	
[4]	Max. speed	
[5]	Stop and trip	

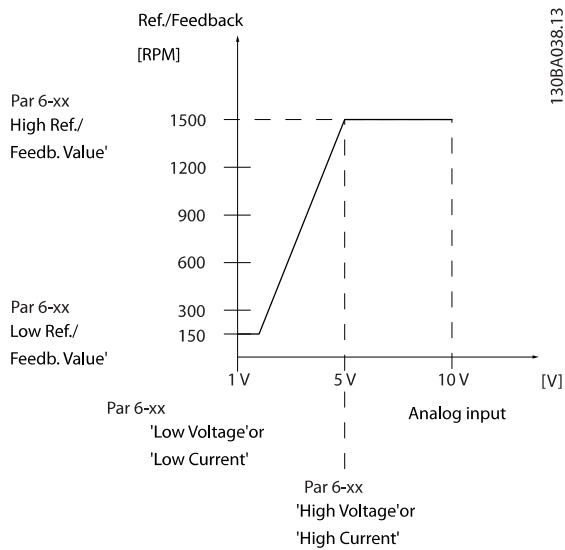

Illustration 3.10 Live Zero Timeout Function

6-02 Fire Mode Live Zero Timeout Function		
Option:	Function:	
		Select the timeout function when the fire mode is active. The function set in this parameter is activated if the input signal on analog inputs is below 50% of the low value for a time period defined in <i>parameter 6-00 Live Zero Timeout Time</i> .
[0] *	Off	
[1]	Freeze output	
[2]	Stop	
[3]	Jogging	
[4]	Max. speed	

### 3.7.2 6-1\* Analog Input 53

Parameters for configuring the scaling and limits for analog input 53 (terminal 53).

6-10 Terminal 53 Low Voltage		
Range:	Function:	
0.07 V*	[0 - 10 V]	Enter the voltage (V) that corresponds to <i>parameter 6-14 Terminal 53 Low Ref./Feedb. Value</i> . To activate <i>parameter 6-01 Live Zero Timeout Function</i> , set the value to >1 V.

6-11 Terminal 53 High Voltage		
Range:	Function:	
10 V*	[0 - 10 V]	Enter the voltage (V) that corresponds to the high reference value (set in

6-11 Terminal 53 High Voltage		
Range:	Function:	
		<i>parameter 6-15 Terminal 53 High Ref./Feedb. Value</i> ).

6-12 Terminal 53 Low Current		
Range:	Function:	
4 mA*	[0 - 20 mA]	Enter the low current value. This reference signal corresponds to the low reference/feedback value that is set in <i>parameter 6-14 Terminal 53 Low Ref./Feedb. Value</i> . To activate <i>parameter 6-01 Live Zero Timeout Function</i> , set the value to >2 mA.

6-13 Terminal 53 High Current		
Range:	Function:	
20 mA*	[0 - 20 mA]	Enter the high current value corresponding to the high reference/feedback set in <i>parameter 6-15 Terminal 53 High Ref./Feedb. Value</i> .

6-14 Terminal 53 Low Ref./Feedb. Value		
Range:	Function:	
0*	[-4999 - 4999 ]	Enter the reference or feedback value that corresponds to the voltage or current set in <i>parameter 6-10 Terminal 53 Low Voltage</i> to <i>parameter 6-12 Terminal 53 Low Current</i> .

6-15 Terminal 53 High Ref./Feedb. Value		
Range:	Function:	
Size related*	[-4999 - 4999 ]	Enter the reference or feedback value that corresponds to the voltage or current set in <i>parameter 6-11 Terminal 53 High Voltage</i> to <i>parameter 6-13 Terminal 53 High Current</i> .

6-16 Terminal 53 Filter Time Constant		
Range:	Function:	
0.01 s*	[0.01 - 10 s]	Enter the time constant. This constant is a first-order digital low-pass filter time constant for suppressing electrical noise in terminal 53. A high time constant value improves dampening, but also increases the time delay through the filter.



6-19 Terminal 53 mode		
Select whether terminal 53 is used for current or voltage input.		
Option:	Function:	
[0]	Current mode	
[1] *	Voltage mode	

### 3.7.3 6-2\* Analog Input 54

Parameters for configuring the scaling and limits for analog input 54 (terminal 54).

6-20 Terminal 54 Low Voltage		
Range:	Function:	
0.07 V*	[0 - 10 V]	Enter the voltage (V) that corresponds to the low reference value (set in <i>parameter 6-24 Terminal 54 Low Ref./Feedb. Value</i> ). To activate <i>parameter 6-01 Live Zero Timeout Function</i> , set the value to >1 V.

6-21 Terminal 54 High Voltage		
Range:	Function:	
10 V*	[0 - 10 V]	Enter the voltage (V) that corresponds to the high reference value (set in <i>parameter 6-25 Terminal 54 High Ref./Feedb. Value</i> ).

6-22 Terminal 54 Low Current		
Range:	Function:	
4 mA*	[0 - 20 mA]	Enter the low current value. This reference signal corresponds to the low reference/feedback value set in <i>parameter 6-24 Terminal 54 Low Ref./Feedb. Value</i> . To activate the live zero timeout function in <i>parameter 6-01 Live Zero Timeout Function</i> , set the value to >2 mA.

6-23 Terminal 54 High Current		
Range:	Function:	
20 mA*	[0 - 20 mA]	Enter the high current value corresponding to the high reference/feedback value set in <i>parameter 6-25 Terminal 54 High Ref./Feedb. Value</i> .

6-24 Terminal 54 Low Ref./Feedb. Value		
Range:	Function:	
0*	[-4999 - 4999 ]	Enter the reference or feedback value that corresponds to the voltage or current set in <i>parameter 6-21 Terminal 54 High</i>

6-24 Terminal 54 Low Ref./Feedb. Value		
Range:	Function:	
		<i>Voltage/parameter 6-22 Terminal 54 Low Current.</i>

6-25 Terminal 54 High Ref./Feedb. Value		
Range:	Function:	
Size related*	[-4999 - 4999 ]	Enter the reference or feedback value that corresponds to the voltage or current set in <i>parameter 6-21 Terminal 54 High Voltage/parameter 6-23 Terminal 54 High Current.</i>

6-26 Terminal 54 Filter Time Constant		
Range:	Function:	
0.01 s*	[0.01 - 10 s]	Enter the time constant, which is a first-order digital low-pass filter time constant for suppressing electrical noise in terminal 54. A high time constant value improves dampening, but also increases the time delay through the filter.

6-29 Terminal 54 mode		
Option:	Function:	
		Select if terminal 54 is used for current input or voltage input.
[0]	Current mode	
[1] *	Voltage mode	

### 3.7.4 6-7\* Analog/Digital Output 45

Parameters for configuring the scaling and limits for analog/digital output terminal 45. Analog outputs are current outputs: 0/4–20 mA. Resolution on analog output is 12 bit. Analog output terminals can also be set up as digital output.

6-70 Terminal 45 Mode		
Set terminal 45 to act as analog output or as digital output.		
Option:	Function:	
[0] *	0-20 mA	
[1]	4-20 mA	
[2]	Digital Output	

6-71 Terminal 45 Analog Output		
Option:	Function:	
		Select the function of terminal 45 as an analog current output. See also <i>parameter 6-70 Terminal 45 Mode</i> .
[254]	DC-link voltage	<ul style="list-style-type: none"> <li>T2/S2, 200–400 V</li> <li>T4, 400–800 V</li> </ul>

**6-71 Terminal 45 Analog Output**

Option:	Function:
	<ul style="list-style-type: none"> <li>T5, 400–1000 V</li> <li>T6, 500–1000 V</li> </ul>
[0] *	No operation
[100]	Output frequency 0–100 Hz
[101]	Reference Min <sub>Ref</sub> –Max <sub>Ref</sub>
[102]	Feedback Min <sub>FB</sub> –Max <sub>FB</sub>
[103]	Motor Current 0–I <sub>max</sub>
[106]	Power 0–P <sub>nom</sub>
[139]	Bus Control 0–100%
[254]	DC Link Voltage 0–65535 V

**6-72 Terminal 45 Digital Output**

Option:	Function:
	Select the function of terminal 45 as a digital current output. See also <i>parameter 6-70 Terminal 45 Mode</i> . See <i>parameter 5-40 Function Relay</i> for description of the options.
[0] *	No operation
[1]	Control Ready
[2]	Drive ready
[3]	Drive ready/ remote control
[4]	Standby / no warning
[5]	Drive running
[6]	Running / no warning
[7]	Run in range/no warning
[8]	Run on ref/no warning
[9]	Alarm
[10]	Alarm or warning
[12]	Out of current range
[13]	Below current, low
[14]	Above current, high
[16]	Below speed, low
[17]	Above speed, high
[19]	Below feedback, low
[20]	Above feedback, high

**6-72 Terminal 45 Digital Output**

Option:	Function:
[21]	Thermal warning
[22]	Ready, no thermal warning
[23]	Remote, ready, no thermal warning
[24]	Ready, Voltage OK
[25]	Reverse
[26]	Bus OK
[35]	External Interlock
[36]	Control word bit 11
[37]	Control word bit 12
[41]	Below reference, low
[42]	Above ref, high
[45]	Bus Control
[60]	Comparator 0
[61]	Comparator 1
[62]	Comparator 2
[63]	Comparator 3
[64]	Comparator 4
[65]	Comparator 5
[70]	Logic rule 0
[71]	Logic rule 1
[72]	Logic rule 2
[73]	Logic rule 3
[74]	Logic rule 4
[75]	Logic rule 5
[80]	SL digital output A
[81]	SL digital output B
[82]	SL digital output C
[83]	SL digital output D
[160]	No alarm
[161]	Running reverse
[165]	Local ref. active
[166]	Remote ref. active
[167]	Start command activ

6-72 Terminal 45 Digital Output		
Option:	Function:	
[168]	Drive in hand mode	
[169]	Drive in auto mode	
[190]	No-Flow	
[193]	Sleep Mode	
[194]	Broken Belt Function	
[196]	Fire Mode	
[198]	Drive Bypass	

6-73 Terminal 45 Output Min Scale		
Range:	Function:	
0 %*	[0 - 200 %]	Scale for the minimum output (0 mA or 4 mA) of the analog signal at terminal 45. Set the value to be the percentage of the full range of the variable selected in <i>parameter 6-71 Terminal 45 Analog Output</i> .

6-74 Terminal 45 Output Max Scale		
Range:	Function:	
100 %*	[0 - 200 %]	Scale for the maximum output (20 mA) of the analog signal at terminal 45. Set the value to be the percentage of the full range of the variable selected in <i>parameter 6-71 Terminal 45 Analog Output</i> .

Current (mA)

20

0/4

0% Analogue Output 100% Variable

output Min Scale Max Scale for output example: Power

par. 6-73 par. 6-74

**Illustration 3.11 Output Maximum Scale**

6-76 Terminal 45 Output Bus Control		
Range:	Function:	
0*	[0 - 16384 ]	Holds the level of analog output if controlled by bus.

### 3.7.5 6-9\* Analog/Digital Output 42

Parameters for configuring the limits for analog/digital output terminal 42. Analog outputs are current outputs: 0/4–20 mA. Resolution on analog outputs is 12 bit. Analog output terminals can also be set up as digital output.

6-90 Terminal 42 Mode		
Set terminal 42 to act as analog output or as digital output.		
Option:	Function:	
[0] *	0-20 mA	
[1]	4-20 mA	
[2]	Digital Output	

6-91 Terminal 42 Analog Output		
Option:	Function:	
		Select the function of terminal 42 as an analog current output. See also <i>parameter 6-90 Terminal 42 Mode</i> .
[254]	DC-link voltage	<ul style="list-style-type: none"> <li>T2/S2, 200–400 V</li> <li>T4, 400–800 V</li> <li>T5, 400–1000 V</li> <li>T6, 500–1000 V</li> </ul>
[0] *	No operation	
[100]	Output frequency	0–100 Hz
[101]	Reference	Min <sub>Ref.</sub> – Max <sub>Ref.</sub>
[102]	Feedback	Min <sub>FB</sub> – Max <sub>FB</sub>
[103]	Motor Current	0–I <sub>max</sub>
[106]	Power	0–P <sub>nom</sub>
[139]	Bus Control	0–100%
[184]	Mirror AI53 mA	0–20
[185]	Mirror AI54 mA	0–20
[254]	DC Link Voltage	0–65535 V

6-92 Terminal 42 Digital Output		
Option:	Function:	
		Select the function of terminal 42 as an analog current output. See also <i>parameter 6-90 Terminal 42 Mode</i> . See <i>parameter 5-40 Function Relay</i> for description of the choices.
[0] *	No operation	
[1]	Control Ready	
[2]	Drive ready	
[3]	Drive ready/ remote control	
[4]	Standby / no warning	
[5]	Drive running	
[6]	Running / no warning	
[7]	Run in range/no warning	

6-92 Terminal 42 Digital Output		
Option:	Function:	
[8]	Run on ref/no warning	
[9]	Alarm	
[10]	Alarm or warning	
[12]	Out of current range	
[13]	Below current, low	
[14]	Above current, high	
[16]	Below speed, low	
[17]	Above speed, high	
[19]	Below feedback, low	
[20]	Above feedback, high	
[21]	Thermal warning	
[22]	Ready, no thermal warning	
[23]	Remote, ready, no thermal warning	
[24]	Ready, Voltage OK	
[25]	Reverse	
[26]	Bus OK	
[35]	External Interlock	
[36]	Control word bit 11	
[37]	Control word bit 12	
[41]	Below reference, low	
[42]	Above ref, high	
[45]	Bus Control	
[60]	Comparator 0	
[61]	Comparator 1	
[62]	Comparator 2	
[63]	Comparator 3	
[64]	Comparator 4	
[65]	Comparator 5	
[70]	Logic rule 0	
[71]	Logic rule 1	
[72]	Logic rule 2	
[73]	Logic rule 3	
[74]	Logic rule 4	

6-92 Terminal 42 Digital Output		
Option:	Function:	
[75]	Logic rule 5	
[80]	SL digital output A	
[81]	SL digital output B	
[82]	SL digital output C	
[83]	SL digital output D	
[160]	No alarm	
[161]	Running reverse	
[165]	Local ref. active	
[166]	Remote ref. active	
[167]	Start command activ	
[168]	Drive in hand mode	
[169]	Drive in auto mode	
[190]	No-Flow	
[193]	Sleep Mode	
[194]	Broken Belt Function	
[196]	Fire Mode	
[198]	Drive Bypass	

6-93 Terminal 42 Output Min Scale		
Range:	Function:	
0 %*	[0 - 200 %]	Scale for the minimum output (0 mA or 4 mA) of the analog signal at terminal 42. Set the value to be the percentage of the full range of the variable selected in <i>parameter 6-91 Terminal 42 Analog Output</i> .

6-94 Terminal 42 Output Max Scale		
Range:	Function:	
100 %*	[0 - 200 %]	Scale for the maximum output (20 mA) of the scaling at terminal 42. Set the value to be the percentage of the full range of the variable selected in <i>parameter 6-91 Terminal 42 Analog Output</i> .

6-94 Terminal 42 Output Max Scale		
Range:		Function:
		<p>130BB772.10</p> <p><b>Illustration 3.12 Output Maximum Scale</b></p>

6-96 Terminal 42 Output Bus Control		
Range:		Function:
0*	[0 - 16384 ]	Hold the analog output at terminal 42 if controlled by bus.

### 3.8 Main Menu - Communications and Options - Group 8

#### 3.8.1 8-0\* General Settings

8-01 Control Site		
Option:		Function:
		This parameter overrules settings in <i>parameter 8-50 Coasting Select</i> to <i>parameter 8-56 Preset Reference Select</i> .
[0] *	Digital and ctrl.word	Control by using both digital input and control word.
[1]	Digital only	Control by using digital inputs only.
[2]	Controlword only	Control by using control word only.

8-02 Control Source		
Option:		Function:
		<p><b>NOTICE</b></p> <p>This parameter cannot be adjusted while the motor is running.</p> <p>Select the source of the control word.</p>
[0]	None	
[1] *	FC Port	

8-03 Control Timeout Time		
Range:		Function:
Size related*	[0.1 - 6500 s]	Enter the maximum time expected to pass between the reception of 2 consecutive telegrams. If this time is exceeded, it indicates that the serial communication has stopped. The function selected in <i>parameter 8-04 Control Timeout Function</i> is carried out.

8-04 Control Timeout Function		
Option:		Function:
		Select the timeout function. The timeout function is activated when the control word fails to be updated within the time period specified in <i>parameter 8-03 Control Timeout Time</i> .
[0] *	Off	
[1]	Freeze output	
[2]	Stop	
[3]	Jogging	
[4]	Max. speed	
[5]	Stop and trip	
[20]	N2 Override Release	This option is valid only when the protocol is N2.

#### 3.8.2 8-3\* Drive

8-30 Protocol		
Option:		Function:
		Select the protocol for the integrated RS485 port.
[0] *	FC	Communication according to the Drive Protocol.
[2]	Modbus RTU	Communication according to the Modbus RTU protocol.
[3]	Metasys N2	Communication protocol. The N2 software protocol is designed to be general in nature to accommodate the unique properties each device may have.
[4]	FLN	Communication according to the FLN protocol.
[5]	BACNet	Communication according to the BACNet protocol.

8-31 Address		
Range:		Function:
Size related*	[ 0.0 - 247 ]	Enter the address for the RS485 port. Valid range: 1-126 for FC-bus OR 1-247 for Modbus.

8-32 Baud Rate		
Option:	Function:	
		Select the baud rate for the RS485 port Default refers to the FC protocol. Changing the protocol in <i>parameter 8-30 Protocol</i> may change the baud rate. Changing protocol in <i>parameter 8-30 Protocol</i> may change the baud rate.
[0]	2400 Baud	
[1]	4800 Baud	Default setting for FLN.
[2]	9600 Baud	Default setting for: <ul style="list-style-type: none"> <li>• BACnet.</li> <li>• Metasys N2.</li> </ul>
[3]	19200 Baud	Default setting for Modbus RTU.
[4]	38400 Baud	
[5]	57600 Baud	
[6]	76800 Baud	
[7]	115200 Baud	

8-33 Parity / Stop Bits		
Option:	Function:	
		Parity and stop bits for the protocol using the FC port. For some of the protocols, not all options are available. Default refers to the FC protocol. Changing protocol in <i>parameter 8-30 Protocol</i> may change the baud rate.
[0]	Even Parity, 1 Stop Bit	
[1]	Odd Parity, 1 Stop Bit	
[2]	No Parity, 1 Stop Bit	
[3]	No Parity, 2 Stop Bits	

8-35 Minimum Response Delay		
Range:	Function:	
Size related* [ 0.0010 - 0.5 s]		Specify the minimum delay time between receiving a request and transmitting a response. This is used for overcoming modem turnaround delays.

8-36 Maximum Response Delay		
Range:	Function:	
Size related* [ 0.1 - 10.0 s]		Specify the maximum permissible delay time between receiving a

8-36 Maximum Response Delay		
Range:	Function:	
		request and transmitting the response. If this time is exceeded, no response is returned.

8-37 Maximum Inter-char delay		
Range:	Function:	
Size related* [ 0.005 - 0.025 s]		Specify the maximum delay time between 2 characters in a message. Exceeding this delay time causes the message to be discarded.

### 3.8.3 8-4\* FC MC Protocol Set

This parameter group is for PCD write and read configurations.

#### 8-42 PCD Write Configuration

Different parameters can be assigned to PCD 3–10 of the PPOs (the number of PCDs depends on the PPO type). The values in PCD 3–10 are written to the selected parameters as data values.

Option:	Function:	
[0]	None	
[1]	[302] Minimum Reference	
[2]	[303] Maximum Reference	
[3]	[341] Ramp 1 Ramp up time	
[4]	[342] Ramp 1 Ramp down time	
[5]	[351] Ramp 2 Ramp up time	
[6]	[352] Ramp 2 Ramp down time	
[7]	[380] Jog Ramp Time	
[8]	[381] Quick Stop Time	
[9]	[412] Motor Speed Low Limit [Hz]	
[10]	[414] Motor Speed High Limit [Hz]	
[11]	[590] Digital & Relay Bus Control	
[12]	[676] Terminal45 Output Bus Control	
[13]	[696] Terminal 42 Output Bus Control	
[14]	[894] Bus Feedback 1	
[15]	FC Port CTW	
[16]	FC Port REF	
[17]	[2021] Setpoint 1	

#### 8-43 PCD Read Configuration

Different parameters can be assigned to PCD 3–10 of the PPOs (the number of PCDs depends on the PPO type). PCD 3–10 hold the actual data value of the selected parameters.

Option:	Function:	
[0]	None	

8-43 PCD Read Configuration		
Different parameters can be assigned to PCD 3–10 of the PPOs (the number of PCDs depends on the PPO type). PCD 3–10 hold the actual data value of the selected parameters.		
Option:	Function:	
[1]	[1500] Operation Hours	
[2]	[1501] Running Hours	
[3]	[1502] kWh Counter	
[4]	[1600] Control Word	
[5]	[1601] Reference [Unit]	
[6]	[1602] Reference %	
[7]	[1603] Status Word	
[8]	[1605] Main Actual Value [%]	
[9]	[1609] Custom Readout	
[10]	[1610] Power [kW]	
[11]	[1611] Power [hp]	
[12]	[1612] Motor Voltage	
[13]	[1613] Frequency	
[14]	[1614] Motor Current	
[15]	[1615] Frequency [%]	
[16]	[1618] Motor Thermal	
[17]	[1630] DC Link Voltage	
[18]	[1634] Heatsink Temp.	
[19]	[1635] Inverter Thermal	
[20]	[1638] SL Controller State	
[21]	[1650] External Reference	
[22]	[1652] Feedback [Unit]	

8-43 PCD Read Configuration		
Different parameters can be assigned to PCD 3–10 of the PPOs (the number of PCDs depends on the PPO type). PCD 3–10 hold the actual data value of the selected parameters.		
Option:	Function:	
[23]	[1660] Digital Input 18,19,27,33	
[24]	[1661] Terminal 53 Switch Setting	
[25]	[1662] Analog input 53	
[26]	[1663] Terminal 54 Switch Setting	
[27]	[1664] Analog input 54	
[28]	[1665] Analog output 42 [mA]	
[29]	[1671] Relay output	
[30]	[1672] Counter A	
[31]	[1673] Counter B	
[32]	[1690] Alarm Word	
[33]	[1692] Warning Word	
[34]	[1694] Ext. Status Word	

### 3.8.4 8-5\* Digital/Bus

Parameters for configuring the control word digital/bus merging.

8-50 Coasting Select		
Select control of the coasting function via the terminals (digital input) and/or via the bus.		
Option:	Function:	
		<b>NOTICE</b> This parameter is active only when <i>parameter 8-01 Control Site</i> is set to [0] Digital and control word.
[0]	Digital input	Activates coast via a digital input.
[1]	Bus	Activates coast via the serial communication port.

8-50 Coasting Select		
Select control of the coasting function via the terminals (digital input) and/or via the bus.		
Option:	Function:	
[2]	Logic AND	Activates coast via the fieldbus/ serial communication port, and via 1 of the digital inputs.
[3] *	Logic OR	Activates coast via the serial communication port or via 1 of the digital inputs.

8-51 Quick Stop Select		
Select control of the quick stop function via the terminals (digital input) and/or via the bus.		
Option:	Function:	
		<b>NOTICE</b> This parameter is active only when <i>parameter 8-01 Control Site</i> is set to [0] Digital and control word.
[0]	Digital input	Activates quick stop via a digital input.
[1]	Bus	Activates quick stop via the serial communication port.
[2]	Logic AND	Activates quick stop via the serial communication port and via 1 of the digital inputs.
[3] *	Logic OR	Activates quick stop via the serial communication port or via 1 of the digital inputs.

8-52 DC Brake Select		
Option:	Function:	
		<b>NOTICE</b> This parameter is active only when <i>parameter 8-01 Control Site</i> is set to [0] Digital and control word.  Select control of the DC brake via the terminals (digital input).
[0]	Digital input	Activates DC brake via a digital input.
[1]	Bus	Activates DC brake via the serial communication port.
[2]	Logic AND	Activates DC brake via the serial communication port and via 1 of the digital inputs.

8-52 DC Brake Select		
Option:	Function:	
[3]	Logic OR	Activates DC brake via the serial communication port or via 1 of the digital inputs.

8-53 Start Select		
Select control of the frequency converter start function via the terminals (digital input).		
Option:	Function:	
		<b>NOTICE</b> This parameter is active only when <i>parameter 8-01 Control Site</i> is set to [0] Digital and control word.
[0]	Digital input	Activates a start command via a digital input.
[1]	Bus	Activates a start command via the serial communication port or fieldbus options.
[2]	Logic AND	Activates a start command via the serial communication port and via 1 of the digital inputs.
[3] *	Logic OR	Activates a start command via the serial communication port or via 1 of the digital inputs.

8-54 Reversing Select		
Select control of the frequency converter reverse function via the terminals (digital input) and/or via the serial communication port.		
Option:	Function:	
		<b>NOTICE</b> This parameter is active only when <i>parameter 8-01 Control Site</i> is set to [0] Digital and control word.
[0] *	Digital input	Activates a reverse command via a digital input.
[1]	Bus	Activates a reverse command via the serial communication port.
[2]	Logic AND	Activates a reverse command via the serial communication port and via 1 of the digital inputs.
[3]	Logic OR	Activates a reverse command via the serial communication port or via 1 of the digital inputs.



8-55 Set-up Select		
Select control of the frequency converter set-up selection via the terminals (digital input) and/or via the serial communication port.		
Option:	Function:	
		<b>NOTICE</b> This parameter is active only when parameter 8-01 Control Site is set to [0] Digital and control word.
[0]	Digital input	Activates the set-up selection via a digital input.
[1]	Bus	Activates the set-up selection via the serial communication port.
[2]	Logic AND	Activates the set-up selection via the serial communication port and via 1 of the digital inputs.
[3] *	Logic OR	Activate the set-up selection via the serial communication port or via 1 of the digital inputs.

8-56 Preset Reference Select		
Select control of the frequency converter preset reference selection via the terminals (digital input) and/or via the serial communication port.		
Option:	Function:	
[0]	Digital input	Activates the preset reference selection via a digital input.
[1]	Bus	Activates the preset reference selection via the serial communication port.
[2]	Logic AND	Activates the preset reference selection via the serial communication port and via 1 of the digital inputs.
[3] *	Logic OR	Activates the preset reference selection via the serial communication port or via 1 of the digital inputs.

### 3.8.5 8-7\* BACnet

8-70 BACnet Device Instance		
Range:	Function:	
1*	[0 - 4194303 ]	Enter a unique ID number for the BACnet device.

8-72 MS/TP Max Masters		
Range:	Function:	
127*	[0 - 127 ]	Define the address of the master, which holds the highest address in

8-72 MS/TP Max Masters		
Range:	Function:	
		this network. Decreasing this value optimizes polling for the token.

8-73 MS/TP Max Info Frames		
Range:	Function:	
1*	[1 - 65534 ]	Define how many info/data frames the device is allowed to send while holding the token.

8-74 "I am" Service		
Option:	Function:	
[0] *	Send at power-up	Select when the device should send the I-Am service message only at power-up.
[1]	Continuously	Select when the device should send the I-Am service message continuously with an interval of approximately 1 minute.

8-75 Intialisation Password		
Range:	Function:	
admin*	[1 - 1 ]	Enter the password needed for execution of Drive Re-initialization from BACnet.

8-79 Protocol Firmware version		
Array[5]		
Range:	Function:	
Size related*	[0 - 655 ]	Firmware revision of frequency converter is in index 0, Modbus is in index 1, Metasys N2 is in index 2, FLN is in index 3, BACnet is in index 4.

### 3.8.6 8-8\* FC Port Diagnostics

These parameters are used for monitoring the bus communication via the Drive port.

8-80 Bus Message Count		
Range:	Function:	
0*	[0 - 4294967295 ]	This parameter shows the number of valid telegrams detected on the bus.

8-81 Bus Error Count		
Range:	Function:	
0*	[0 - 4294967295 ]	This parameter shows the number of telegrams with faults (for example, CRC fault), detected on the bus.

8-82 Slave Messages Rcvd		
Range:		Function:
0*	[0 - 4294967295 ]	This parameter shows the number of valid telegrams addressed to the slave, sent by the frequency converter.

8-83 Slave Error Count		
Range:		Function:
0*	[0 - 4294967295 ]	This parameter shows the number of error telegrams, which the frequency converter could not execute.

8-84 Slave Messages Sent		
Range:		Function:
0*	[0 - 4294967295 ]	This parameter shows the number of messages sent from the slave.

8-85 Slave Timeout Errors		
Range:		Function:
0*	[0 - 4294967295 ]	This parameter shows the number of slave timeout errors.

8-88 Reset FC port Diagnostics		
Option:		Function:
[0] *	Do not reset	
[1]	Reset counter	

### 3.8.7 8-9\* Bus Feedback

8-94 Bus Feedback 1		
Range:		Function:
0*	[-32768 - 32767 ]	Write feedback to this parameter via the serial communication port. Select this parameter in <i>parameter 20-00 Feedback 1 Source</i> or <i>parameter 20-03 Feedback 2 Source</i> as a feedback source. Hex value 4000 h corresponds to 100% feedback/range is $\pm 200\%$ .

8-95 Bus Feedback 2		
Range:		Function:
0*	[-32768 - 32767 ]	Write a feedback to this parameter via the serial communication port. This parameter must be selected in <i>parameter 20-00 Feedback 1 Source</i> or <i>parameter 20-03 Feedback 2 Source</i> as a feedback source. The hexadecimal value 4000 h corresponds to $\pm 200\%$ in 100% feedback/range.

### 3.9 Main Menu - Smart Logic - Group 13

#### 3.9.1 13-\*\* Prog. Features

Smart logic control (SLC) is a sequence of user-defined actions (see *parameter 13-52 SL Controller Action [x]*) executed by the SLC when the SLC evaluates the associated user-defined event (see *parameter 13-51 SL Controller Event [x]*) as true.

Events and actions are each numbered and linked in pairs. This means that when [0] event is fulfilled (attains the value true), [0] action is executed. After executing this action, the conditions of [1] event is evaluated. If it is evaluated as true, [1] action is executed, and so on. Only 1 event is evaluated at any time. If an event is evaluated as false, nothing happens (in the SLC) during the current scan interval and no other events are evaluated. This means that when the SLC starts, it evaluates [0] event (and only [0] event) each scan interval. Only when [0] event is evaluated as true, the SLC executes [0] action and starts evaluating [1] event. It is possible to program from 1–20 events and actions. When the last event/action has been executed, the sequence starts over again from [0] event/[0] action.

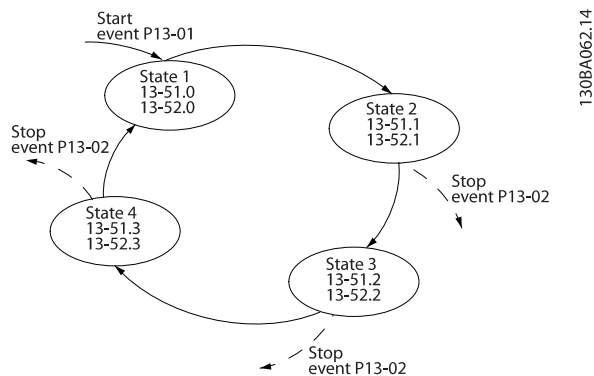

Illustration 3.13 Example with 3 Event/Actions

#### Starting and stopping the SLC

To start or stop the SLC, select [1] On or [2] Off in *parameter 13-00 SL Controller Mode*. The SLC always starts in state 0 (where it evaluates [0] event). The SLC starts when the start event (defined in *parameter 13-01 Start Event*) is evaluated as true (if [1] On is selected in *parameter 13-00 SL Controller Mode*). The SLC stops when the stop event (*parameter 13-02 Stop Event*) is true. *Parameter 13-03 Reset SLC* resets all SLC parameters and starts programming from the beginning.

#### 3.9.2 13-0\* SLC Settings

To activate, deactivate, and reset the smart logic control sequence, use the SLC settings. The logic functions and comparators are always running in the background, which opens for separate control of digital inputs and outputs.

13-00 SL Controller Mode		
To enable the smart logic control to start when a start command is present, for example, via a digital input, Select [1] On. To disable the smart logic control, select [0] Off.		
Option:	Function:	
[0] *	Off	Disables the smart logic controller.
[1]	On	Enables the smart logic controller.

13-01 Start Event		
Option:	Function:	
		To activate smart logic control, select the boolean (true or false) input.
[0]	False	Enters the fixed value of false in the logic rule.
[1]	True	Enters the fixed value of true in the logic rule.
[2]	Running	The motor runs.
[3]	In range	The motor runs within programmed current ranges ( <i>parameter 4-50 Warning Current Low</i> and <i>parameter 4-51 Warning Current High</i> ).
[4]	On reference	The motor runs at reference speed.
[7]	Out of current range	The motor current is outside the range set in <i>parameter 4-18 Current Limit</i> .
[8]	Below I low	The motor current is lower than set in <i>parameter 4-50 Warning Current Low</i> .
[9]	Above I high	The motor current is higher than set in <i>parameter 4-51 Warning Current High</i> .
[16]	Thermal warning	The thermal warning turns on when the temperature exceeds the limit in the motor, the frequency converter, or the thermistor.
[17]	Mains out of range	Mains phase loss warning or alarm, if <i>parameter 14-12 Function at Mains Imbalance</i> is not set at [2] Disabled.
[18]	Reversing	The frequency converter reverses.
[19]	Warning	A warning is present.
[20]	Alarm (trip)	An alarm is present.

13-01 Start Event		
Option:	Function:	
[21]	Alarm (trip lock)	A trip lock alarm is present.
[22]	Comparator 0	Use the result of comparator 0 in the logic rule.
[23]	Comparator 1	Use the result of comparator 1 in the logic rule.
[24]	Comparator 2	Use the result of comparator 2 in the logic rule.
[25]	Comparator 3	Use the result of comparator 3 in the logic rule.
[26]	Logic rule 0	Use the result of logic rule 0 in the logic rule.
[27]	Logic rule 1	Use the result of logic rule 1 in the logic rule.
[28]	Logic rule 2	Use the result of logic rule 2 in the logic rule.
[29]	Logic rule 3	Use the result of logic rule 3 in the logic rule.
[33]	Digital input DI18	Use the value of DI18 in the logic rule (High = true).
[34]	Digital input DI19	Use the value of DI19 in the logic rule (High = true).
[35]	Digital input DI27	Use the value of DI27 in the logic rule (High = true).
[36]	Digital input DI29	Use the value of DI29 in the logic rule (High = true).
[39] *	Start command	This event is true if the frequency converter is started (either via digital input, fieldbus, or other).
[40]	Drive stopped	This event is true if the frequency converter is stopped or coasted (either via digital input, fieldbus, or other).
[42]	Auto Reset Trip	This event is true if the frequency converter is tripped (but not trip-locked) and an automatic reset is issued.
[50]	Comparator 4	Use the result of comparator 4 in the logic rule.
[51]	Comparator 5	Use the result of comparator 5 in the logic rule.
[60]	Logic rule 4	Use the result of logic rule 4 in the logic rule.
[61]	Logic rule 5	Use the result of logic rule 5 in the logic rule.
[83]	Broken Belt	A broken-belt condition is detected. Enable this function in

13-01 Start Event		
Option:	Function:	
		<i>parameter 22-60 Broken Belt Function.</i>
13-02 Stop Event		
Option:	Function:	
		Select the condition (true or false) which deactivates the smart logic controller.
[0]	False	Enters the fixed value of false in the logic rule.
[1]	True	Enters the fixed value of true in the logic rule.
[2]	Running	See <i>parameter 13-01 Start Event</i> for further description.
[3]	In range	See <i>parameter 13-01 Start Event</i> for further description.
[4]	On reference	See <i>parameter 13-01 Start Event</i> for further description.
[7]	Out of current range	See <i>parameter 13-01 Start Event</i> for further description.
[8]	Below I low	See <i>parameter 13-01 Start Event</i> for further description.
[9]	Above I high	See <i>parameter 13-01 Start Event</i> for further description.
[16]	Thermal warning	See <i>parameter 13-01 Start Event</i> for further description.
[17]	Mains out of range	See <i>parameter 13-01 Start Event</i> for further description.
[18]	Reversing	See <i>parameter 13-01 Start Event</i> for further description.
[19]	Warning	See <i>parameter 13-01 Start Event</i> for further description.
[20]	Alarm (trip)	See <i>parameter 13-01 Start Event</i> for further description.
[21]	Alarm (trip lock)	See <i>parameter 13-01 Start Event</i> for further description.
[22]	Comparator 0	Use the result of comparator 0 in the logic rule.
[23]	Comparator 1	Use the result of comparator 1 in the logic rule.
[24]	Comparator 2	Use the result of comparator 2 in the logic rule.
[25]	Comparator 3	Use the result of comparator 3 in the logic rule.
[26]	Logic rule 0	Use the result of logic rule 0 in the logic rule.

13-02 Stop Event		
Option:	Function:	
[27]	Logic rule 1	Use the result of logic rule 1 in the logic rule.
[28]	Logic rule 2	Use the result of logic rule 2 in the logic rule.
[29]	Logic rule 3	Use the result of logic rule 3 in the logic rule.
[30]	SL Time-out 0	Use the result of timer 0 in the logic rule.
[31]	SL Time-out 1	Use the result of timer 1 in the logic rule.
[32]	SL Time-out 2	Use the result of timer 2 in the logic rule.
[33]	Digital input DI18	Use the value of DI18 in the logic rule (High = true).
[34]	Digital input DI19	Use the value of DI19 in the logic rule (High = true).
[35]	Digital input DI27	Use the value of DI27 in the logic rule (High = true).
[36]	Digital input DI29	Use the value of DI29 in the logic rule (High = true).
[39]	Start command	This event is true if the frequency converter is started by any means (either via digital input, fieldbus, or other).
[40] *	Drive stopped	This event is true if the frequency converter is stopped or coasted by any means (either via digital input, fieldbus, or other).
[42]	Auto Reset Trip	This event is true if the frequency converter is tripped (but not trip-locked) and an automatic reset is issued.
[50]	Comparator 4	Use the result of comparator 4 in the logic rule.
[51]	Comparator 5	Use the result of comparator 5 in the logic rule.
[60]	Logic rule 4	Use the result of logic rule 4 in the logic rule.
[61]	Logic rule 5	Use the result of logic rule 5 in the logic rule.
[70]	SL Time-out 3	Use the result of timer 3 in the logic rule.
[71]	SL Time-out 4	Use the result of timer 4 in the logic rule.
[72]	SL Time-out 5	Use the result of timer 5 in the logic rule.

13-02 Stop Event		
Option:	Function:	
[73]	SL Time-out 6	Use the result of timer 6 in the logic rule.
[74]	SL Time-out 7	Use the result of timer 7 in the logic rule.
[83]	Broken Belt	A broken-belt condition has been detected. Enable this function in <i>parameter 22-60 Broken Belt Function</i> .

13-03 Reset SLC		
Option:	Function:	
[0] *	Do not reset SLC	Retains programmed settings in <i>parameter group 13-** Smart Logic</i> .
[1]	Reset SLC	Resets all parameters in <i>parameter group 13-** Smart Logic</i> to default settings.

### 3.9.3 13-1\* Comparators

Comparators are used for comparing continuous variables (such as output frequency, output current, and analog input) to fixed preset values.

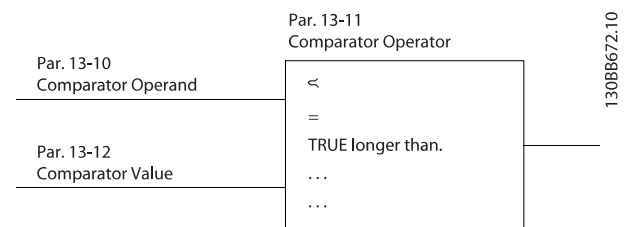

Illustration 3.14 Comparators

In addition, there are digital values that are compared to fixed time values. See the explanation in *parameter 13-10 Comparator Operand*. Comparators are evaluated once in each scan interval. Use the result (true or false) directly. All parameters in this parameter group are array parameters with index 0–5. Select index 0 to program comparator 0, select index 1 to program comparator 1, and so on.

13-10 Comparator Operand		
Array [6] Select the variable to be monitored by the comparator.		
Option:	Function:	
[0] *	Disabled	
[1]	Reference	
[2]	Feedback	
[3]	Motor speed	
[4]	Motor Current	
[6]	Motor power	

13-10 Comparator Operand		
Array [6] Select the variable to be monitored by the comparator.		
Option:	Function:	
[7]	Motor voltage	
[12]	Analog input AI53	
[13]	Analog input AI54	
[20]	Alarm number	
[30]	Counter A	
[31]	Counter B	

13-11 Comparator Operator		
Array [6]		
Option:	Function:	
[0]	Less Than (<)	Select [0] < for the result of the evaluation to be true, when the variable selected in <i>parameter 13-10 Comparator Operand</i> is smaller than the fixed value in <i>parameter 13-12 Comparator Value</i> . The result is false, if the variable selected in <i>parameter 13-10 Comparator Operand</i> is greater than the fixed value in <i>parameter 13-12 Comparator Value</i> .
[1] *	Approx.Equal (~)	Select [1] ≈ for the result of the evaluation to be true, when the variable selected in <i>parameter 13-10 Comparator Operand</i> is approximately equal to the fixed value in <i>parameter 13-12 Comparator Value</i> .
[2]	Greater Than (>)	Select [2] > for the inverse logic of option [0] <.

13-12 Comparator Value		
Array [6]		
Range:	Function:	
0*	[-9999 - 9999 ]	Enter the trigger level for the variable that is monitored by this comparator. This parameter is an array parameter containing comparator values 0–5.

### 3.9.4 13-2\* Timers

Use the result (true or false) from timers directly to define an event (see *parameter 13-51 SL Controller Event*), or as boolean input in a logic rule (see *parameter 13-40 Logic Rule Boolean 1*, *parameter 13-42 Logic Rule Boolean 2*, or

*parameter 13-44 Logic Rule Boolean 3*). A timer is only false when started by an action (for example [29] *Start timer 1*) until the timer value entered in this parameter has elapsed. Then it becomes true again.

All parameters in this parameter group are array parameters with index 0–2. Select index 0 to program timer 0, select index 1 to program timer 1, and so on.

13-20 SL Controller Timer		
Array [8]		
Range:	Function:	
0 s*	[0 - 3600 s]	Enter the value to define the duration of the false output from the programmed timer. A timer is only false if it is started by an action (see <i>parameter 13-52 SL Controller Action [29–31]</i> and <i>parameter 13-52 SL Controller Action [70–74] Start timer X</i> ) and until the timer value has elapsed. Array parameters contain timers 0–7.

### 3.9.5 13-4\* Logic Rules

Combine up to 3 boolean inputs (true/false inputs) from timers, comparators, digital inputs, status bits, and events using the logical operators AND, OR, and NOT. Select boolean inputs for the calculation in *parameter 13-40 Logic Rule Boolean 1*, *parameter 13-42 Logic Rule Boolean 2*, and *parameter 13-44 Logic Rule Boolean 3*. Define the operators used to combine the selected inputs logically in *parameter 13-41 Logic Rule Operator 1* and *parameter 13-43 Logic Rule Operator 2*.

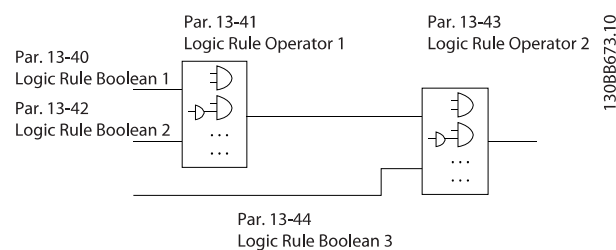

Illustration 3.15 Logic Rules

#### Priority of calculation

The results of *parameter 13-40 Logic Rule Boolean 1*, *parameter 13-41 Logic Rule Operator 1*, and *parameter 13-42 Logic Rule Boolean 2* are calculated first. The outcome (true/false) of this calculation is combined with the settings of *parameter 13-43 Logic Rule Operator 2* and *parameter 13-44 Logic Rule Boolean 3*, yielding the final result (true/false) of the logic rule.

13-40 Logic Rule Boolean 1		
Array [6]		
Option:	Function:	
[0] *	False	Enters the fixed value of false in the logic rule.
[1]	True	Enters the fixed value true in the logic rule.
[2]	Running	See <i>parameter 13-01 Start Event</i> for further description.
[3]	In range	See <i>parameter 13-01 Start Event</i> for further description.
[4]	On reference	See <i>parameter 13-01 Start Event</i> for further description.
[7]	Out of current range	See <i>parameter 13-01 Start Event</i> for further description.
[8]	Below I low	See <i>parameter 13-01 Start Event</i> for further description.
[9]	Above I high	See <i>parameter 13-01 Start Event</i> for further description.
[16]	Thermal warning	See <i>parameter 13-01 Start Event</i> for further description.
[17]	Mains out of range	See <i>parameter 13-01 Start Event</i> for further description.
[18]	Reversing	See <i>parameter 13-01 Start Event</i> for further description.
[19]	Warning	See <i>parameter 13-01 Start Event</i> for further description.
[20]	Alarm (trip)	See <i>parameter 13-01 Start Event</i> for further description.
[21]	Alarm (trip lock)	See <i>parameter 13-01 Start Event</i> for further description.
[22]	Comparator 0	Use the result of comparator 0 in the logic rule.
[23]	Comparator 1	Use the result of comparator 1 in the logic rule.
[24]	Comparator 2	Use the result of comparator 2 in the logic rule.
[25]	Comparator 3	Use the result of comparator 3 in the logic rule.
[26]	Logic rule 0	Use the result of logic rule 0 in the logic rule.
[27]	Logic rule 1	Use the result of logic rule 1 in the logic rule.
[28]	Logic rule 2	Use the result of logic rule 2 in the logic rule.
[29]	Logic rule 3	Use the result of logic rule 3 in the logic rule.

13-40 Logic Rule Boolean 1		
Array [6]		
Option:	Function:	
[30]	SL Time-out 0	Use the result of timer 0 in the logic rule.
[31]	SL Time-out 1	Use the result of timer 1 in the logic rule.
[32]	SL Time-out 2	Use the result of timer 2 in the logic rule.
[33]	Digital input DI18	Use the value of DI18 in the logic rule (High = true).
[34]	Digital input DI19	Use the value of DI19 in the logic rule (High = true).
[35]	Digital input DI27	Use the value of DI27 in the logic rule (High = true).
[36]	Digital input DI29	Use the value of DI29 in the logic rule (High = true).
[39]	Start command	This logic rule is true if the frequency converter is started by any means (either via digital input, or other).
[40]	Drive stopped	This logic rule is true if the frequency converter is stopped or coasted by any means (either via digital input, or other).
[42]	Auto Reset Trip	This logic rule is true if the frequency converter is tripped (but not trip-locked) and an automatic reset is issued.
[50]	Comparator 4	Use the result of comparator 4 in the logic rule.
[51]	Comparator 5	Use the result of comparator 5 in the logic rule.
[60]	Logic rule 4	Use the result of logic rule 4 in the logic rule.
[61]	Logic rule 5	Use the result of logic rule 5 in the logic rule.
[70]	SL Time-out 3	Use the result of timer 3 in the logic rule.
[71]	SL Time-out 4	Use the result of timer 4 in the logic rule.
[72]	SL Time-out 5	Use the result of timer 5 in the logic rule.
[73]	SL Time-out 6	Use the result of timer 6 in the logic rule.
[74]	SL Time-out 7	Use the result of timer 7 in the logic rule.
[83]	Broken Belt	A broken-belt condition has been detected. Enable this function in

13-40 Logic Rule Boolean 1		
Array [6]		
Option:	Function:	
		<i>parameter 22-60 Broken Belt Function.</i>

13-41 Logic Rule Operator 1		
Option:	Function:	
[0] *	Disabled	
[1]	AND	
[2]	OR	
[3]	AND NOT	
[4]	OR NOT	
[5]	NOT AND	
[6]	NOT OR	
[7]	NOT AND NOT	
[8]	NOT OR NOT	

13-42 Logic Rule Boolean 2		
Array [6]		
Option:	Function:	
		Select the 2 <sup>nd</sup> boolean (true or false) input for the selected logic rule.  See <i>parameter 13-40 Logic Rule Boolean 1</i> for further descriptions of options and their functions.
[0] *	False	
[1]	True	
[2]	Running	
[3]	In range	
[4]	On reference	
[7]	Out of current range	
[8]	Below I low	
[9]	Above I high	
[16]	Thermal warning	
[17]	Mains out of range	
[18]	Reversing	
[19]	Warning	
[20]	Alarm (trip)	
[21]	Alarm (trip lock)	
[22]	Comparator 0	
[23]	Comparator 1	
[24]	Comparator 2	
[25]	Comparator 3	
[26]	Logic rule 0	
[27]	Logic rule 1	
[28]	Logic rule 2	
[29]	Logic rule 3	
[30]	SL Time-out 0	

13-42 Logic Rule Boolean 2		
Array [6]		
Option:	Function:	
[31]	SL Time-out 1	
[32]	SL Time-out 2	
[33]	Digital input DI18	
[34]	Digital input DI19	
[35]	Digital input DI27	
[36]	Digital input DI29	
[39]	Start command	
[40]	Drive stopped	
[42]	Auto Reset Trip	
[50]	Comparator 4	
[51]	Comparator 5	
[60]	Logic rule 4	
[61]	Logic rule 5	
[70]	SL Time-out 3	
[71]	SL Time-out 4	
[72]	SL Time-out 5	
[73]	SL Time-out 6	
[74]	SL Time-out 7	
[83]	Broken Belt	A broken-belt condition has been detected. Enable this function in <i>parameter 22-60 Broken Belt Function.</i>

13-43 Logic Rule Operator 2		
Array [6]		
Select the 2 <sup>nd</sup> logical operator to be used on the boolean input calculated in <i>parameter 13-40 Logic Rule Boolean 1</i> , <i>parameter 13-41 Logic Rule Operator 1</i> , <i>parameter 13-42 Logic Rule Boolean 2</i> , and the boolean input coming from <i>parameter 13-42 Logic Rule Boolean 2</i> . [13-44] signifies the boolean input of <i>parameter 13-44 Logic Rule Boolean 3</i> . [13-40/13-42] signifies the boolean input calculated in <i>parameter 13-40 Logic Rule Boolean 1</i> , <i>parameter 13-41 Logic Rule Operator 1</i> , and <i>parameter 13-42 Logic Rule Boolean 2</i> . [0] Disabled (factory setting): Select this option to ignore <i>parameter 13-44 Logic Rule Boolean 3</i> .		
Option:	Function:	
[0] *	Disabled	
[1]	AND	
[2]	OR	
[3]	AND NOT	
[4]	OR NOT	
[5]	NOT AND	
[6]	NOT OR	
[7]	NOT AND NOT	



13-43 Logic Rule Operator 2		
Array [6]		
Select the 2 <sup>nd</sup> logical operator to be used on the boolean input calculated in <i>parameter 13-40 Logic Rule Boolean 1</i> , <i>parameter 13-41 Logic Rule Operator 1</i> , <i>parameter 13-42 Logic Rule Boolean 2</i> , and the boolean input coming from <i>parameter 13-42 Logic Rule Boolean 2</i> .		
[13-44] signifies the boolean input of <i>parameter 13-44 Logic Rule Boolean 3</i> .		
[13-40/13-42] signifies the boolean input calculated in <i>parameter 13-40 Logic Rule Boolean 1</i> , <i>parameter 13-41 Logic Rule Operator 1</i> , and <i>parameter 13-42 Logic Rule Boolean 2</i> . [0] Disabled (factory setting): Select this option to ignore <i>parameter 13-44 Logic Rule Boolean 3</i> .		
<b>Option:</b>	<b>Function:</b>	
[8]	NOT OR NOT	

13-44 Logic Rule Boolean 3		
Array [6]		
<b>Option:</b>	<b>Function:</b>	
		Select the 3 <sup>rd</sup> boolean (true or false) input for the selected logic rule. See <i>parameter 13-40 Logic Rule Boolean 1</i> for further descriptions of options and their functions.
[0] *	False	
[1]	True	
[2]	Running	
[3]	In range	
[4]	On reference	
[7]	Out of current range	
[8]	Below I low	
[9]	Above I high	
[16]	Thermal warning	
[17]	Mains out of range	
[18]	Reversing	
[19]	Warning	
[20]	Alarm (trip)	
[21]	Alarm (trip lock)	
[22]	Comparator 0	
[23]	Comparator 1	
[24]	Comparator 2	
[25]	Comparator 3	
[26]	Logic rule 0	
[27]	Logic rule 1	
[28]	Logic rule 2	
[29]	Logic rule 3	
[30]	SL Time-out 0	
[31]	SL Time-out 1	
[32]	SL Time-out 2	

13-44 Logic Rule Boolean 3		
Array [6]		
<b>Option:</b>	<b>Function:</b>	
[33]	Digital input DI18	
[34]	Digital input DI19	
[35]	Digital input DI27	
[36]	Digital input DI29	
[39]	Start command	
[40]	Drive stopped	
[42]	Auto Reset Trip	
[50]	Comparator 4	
[51]	Comparator 5	
[60]	Logic rule 4	
[61]	Logic rule 5	
[70]	SL Time-out 3	
[71]	SL Time-out 4	
[72]	SL Time-out 5	
[73]	SL Time-out 6	
[74]	SL Time-out 7	
[83]	Broken Belt	

### 3.9.6 13-5\* States

13-51 SL Controller Event		
Array [20]		
<b>Option:</b>	<b>Function:</b>	
		Select the boolean input (true or false) to define the smart logic controller event. See <i>parameter 13-02 Stop Event</i> for further descriptions of options and their functions.
[0] *	False	
[1]	True	
[2]	Running	
[3]	In range	
[4]	On reference	
[7]	Out of current range	
[8]	Below I low	
[9]	Above I high	
[16]	Thermal warning	
[17]	Mains out of range	
[18]	Reversing	
[19]	Warning	

13-51 SL Controller Event		
Array [20]		
Option:	Function:	
[20]	Alarm (trip)	
[21]	Alarm (trip lock)	
[22]	Comparator 0	
[23]	Comparator 1	
[24]	Comparator 2	
[25]	Comparator 3	
[26]	Logic rule 0	
[27]	Logic rule 1	
[28]	Logic rule 2	
[29]	Logic rule 3	
[30]	SL Time-out 0	
[31]	SL Time-out 1	
[32]	SL Time-out 2	
[33]	Digital input DI18	
[34]	Digital input DI19	
[35]	Digital input DI27	
[36]	Digital input DI29	
[39]	Start command	
[40]	Drive stopped	
[42]	Auto Reset Trip	
[50]	Comparator 4	
[51]	Comparator 5	
[60]	Logic rule 4	
[61]	Logic rule 5	
[70]	SL Time-out 3	
[71]	SL Time-out 4	
[72]	SL Time-out 5	
[73]	SL Time-out 6	
[74]	SL Time-out 7	
[83]	Broken Belt	

13-52 SL Controller Action		
Array [20]		
Option:	Function:	
		Select the action corresponding to the SLC event. Actions are executed when the corresponding event (defined in <i>parameter 13-51 SL Controller Event</i> ) is evaluated as true. The following actions are available for selection:
[100]	ResetAlarm	
[0] *	Disabled	
[1]	No action	

13-52 SL Controller Action		
Array [20]		
Option:	Function:	
[2]	Select set-up 1	Changes the active set-up ( <i>parameter 0-10 Active Set-up</i> ) to set-up 1.
[3]	Select set-up 2	Changes the active set-up ( <i>parameter 0-10 Active Set-up</i> ) to set-up 2.
[10]	Select preset ref 0	Selects preset reference 0.
[11]	Select preset ref 1	Selects preset reference 1.
[12]	Select preset ref 2	Selects preset reference 2.
[13]	Select preset ref 3	Selects preset reference 3.
[14]	Select preset ref 4	Selects preset reference 4.
[15]	Select preset ref 5	Selects preset reference 5.
[16]	Select preset ref 6	Selects preset reference 6.
[17]	Select preset ref 7	Selects preset reference 7. If the active preset reference is changed, it merges with other preset reference commands coming from either the digital inputs or via a fieldbus.
[18]	Select ramp 1	Selects ramp 1.
[19]	Select ramp 2	Selects ramp 2.
[22]	Run	Issues a start command to the frequency converter.
[23]	Run reverse	Issues a start reverse command to the frequency converter.
[24]	Stop	Issues a stop command to the frequency converter.
[25]	Qstop	Issues a quick stop command to the frequency converter.
[26]	DC Brake	Issues a DC stop command to the frequency converter.
[27]	Coast	The frequency converter coasts immediately. All stop commands including the coast command stop the SLC.
[28]	Freeze output	Freezes the output frequency of the frequency converter.
[29]	Start timer 0	Starts timer 0, see <i>parameter 13-20 SL Controller Timer</i> for further description.
[30]	Start timer 1	Starts timer 1, see <i>parameter 13-20 SL Controller Timer</i> for further description.
[31]	Start timer 2	Starts timer 2, see <i>parameter 13-20 SL Controller Timer</i> for further description.
[32]	Set digital out A low	Any output with <i>digital output 1</i> selected is low (off).

13-52 SL Controller Action		
Array [20]		
Option:	Function:	
[33]	Set digital out B low	Any output with <i>digital output 2</i> selected is low (off).
[34]	Set digital out C low	Any output with <i>digital output 3</i> selected is low (off).
[35]	Set digital out D low	Any output with <i>digital output 4</i> selected is low (off).
[38]	Set digital out A high	Any output with <i>digital output 1</i> selected is high (closed).
[39]	Set digital out B high	Any output with <i>digital output 2</i> selected is high (closed).
[40]	Set digital out C high	Any output with <i>digital output 3</i> selected is high (closed).
[41]	Set digital out D high	Any output with <i>digital output 4</i> selected is high (closed).
[60]	Reset Counter A	Resets counter A to 0.
[61]	Reset Counter B	Resets counter B to 0.
[70]	Start Timer 3	Starts timer 3, see <i>parameter 13-20 SL Controller Timer</i> for further description.
[71]	Start Timer 4	Starts timer 4, see <i>parameter 13-20 SL Controller Timer</i> for further description.
[72]	Start Timer 5	Starts timer 5, see <i>parameter 13-20 SL Controller Timer</i> for further description.
[73]	Start Timer 6	Starts timer 6, see <i>parameter 13-20 SL Controller Timer</i> for further description.
[74]	Start Timer 7	Starts timer 7, see <i>parameter 13-20 SL Controller Timer</i> for further description.
[100]	Reset Alarm	Reset the alarm.

### 3.10 Main Menu - Special Functions - Group 14

#### 3.10.1 14-0\* Inverter Switching

14-01 Switching Frequency		
Option:	Function:	
		Select the inverter switching frequency. Changing the switching frequency can help to reduce acoustic noise from the motor.
		<b>NOTICE</b> High switching frequencies increase heat generation in the frequency converter and may reduce its lifetime.
		<b>NOTICE</b> Not all options are available in all power sizes.
		NOTE: The output frequency value of the frequency converter must

14-01 Switching Frequency		
Option:	Function:	
		never exceed 1/10 of the switching frequency. When the motor runs, adjust the switching frequency in <i>parameter 14-01 Switching Frequency</i> until the motor is as noiseless as possible. See also <i>parameter 14-00 Switching Pattern</i> and the section <i>Derating</i> .
[0]	Ran3	3 kHz true random PWM (white noise modulation).
[1]	Ran5	5 kHz true random PWM (white noise modulation).
[2]	2.0 kHz	
[3]	3.0 kHz	
[4]	4.0 kHz	
[5]	5.0 kHz	
[6]	6.0 kHz	
[7]	8.0 kHz	
[8]	10.0 kHz	
[9]	12.0 kHz	
[10]	16.0 kHz	

14-03 Overmodulation		
Option:	Function:	
[0] *	Off	Selects no overmodulation of the output voltage to avoid torque ripple on the motor shaft.
[1]	On	The overmodulation function generates an extra voltage of up to 8% of $U_{max}$ output voltage without overmodulation, which results in an extra torque of 10–12% in the middle of the over-synchronous range (from 0% at nominal speed rising to approximately 12% at double nominal speed).

14-07 Dead Time Compensation Level		
Range:	Function:	
Size related*	[0 - 100 ]	Level of applied dead time compensation in percentage. A high level (>90%) optimizes the dynamic motor response. A level 50–90% is suitable for both motor-torque-ripple minimization and motor dynamics. A 0 level turns off the dead time compensation.

14-08 Damping Gain Factor		
Range:	Function:	
Size related*	[0 - 100 %]	Set the damping factor for DC-link voltage compensation. See

14-08 Damping Gain Factor		
Range:		Function:
		parameter 14-51 DC-Link Voltage Compensation.

14-09 Dead Time Bias Current Level		
Range:		Function:
Size related*	[0 - 100 %]	To add to the current-sense signal for dead time compensation for some motors, set a bias signal (in percentage).

### 3.10.2 14-1\* Mains On/Off

Parameters for configuring mains failure monitoring and handling.

14-10 Mains Failure		
Configure the action of the frequency converter when the mains voltage is below the mains voltage limit configured in parameter 14-11 Mains Fault Voltage Level.		
Option:		Function:
[0] *	No function	
[1]	Ctrl. ramp-down	
[3]	Coasting	
[4]	Kinetic back-up	
[5]	Kinetic back-up, trip	
[6]	Alarm	
[7]	Kin. back-up, trip w recovery	

14-11 Mains Fault Voltage Level		
Range:		Function:
Size related*	[100 - 800 V]	Use this parameter to define at which AC voltage the function selected in parameter 14-10 Mains Failure should be activated.

14-12 Function at Mains Imbalance		
Option:		Function:
		<b>NOTICE</b> Selecting this option may reduce the lifetime of the frequency converter. Operation under severe mains imbalance conditions reduces the lifetime of the motor. If the motor is operated continuously near nominal load, conditions are considered severe. When a severe mains imbalance is detected, select 1 of the available functions.
[0] *	Trip	Trips the frequency converter.
[1]	Warning	Issues a warning.

14-12 Function at Mains Imbalance		
Option:		Function:
[2]	Disabled	No action.
[3]	Derate	The frequency converter would derate.

### 3.10.3 14-2\* Trip Reset

14-20 Reset Mode		
Select the reset function after tripping. Once reset, the frequency converter can be restarted.		
Option:		Function:
[0] *	Manual reset	Select [0] Manual reset to reset the frequency converter via [Reset] or via the digital inputs.
[1]	Automatic reset x 1	Select [1]-[12] Automatic reset x 1... x20 to perform between 1 and 20 automatic resets after tripping.
[2]	Automatic reset x 2	
[3]	Automatic reset x 3	
[4]	Automatic reset x 4	
[5]	Automatic reset x 5	
[6]	Automatic reset x 6	
[7]	Automatic reset x 7	
[8]	Automatic reset x 8	
[9]	Automatic reset x 9	
[10]	Automatic reset x 10	
[11]	Automatic reset x 15	
[12]	Automatic reset x 20	
[13]	Infinite auto reset	Select [13] Infinite Automatic Reset for continuous resetting after tripping.

14-21 Automatic Restart Time		
Range:		Function:
10 s*	[0 - 600 s]	To start the automatic reset function, enter the time interval from trip. This parameter is active when parameter 14-20 Reset Mode is set to [1] - [13] Automatic reset.

14-22 Operation Mode		
Option:	Function:	
		To reset all parameter values to default, select [2] <i>Initialisation</i> .
[0] *	Normal operation	Select [0] <i>Normal operation</i> for normal operation of the frequency converter with the motor in the selected application.
[2]	Initialisation	Select [2] <i>Initialisation</i> to reset all parameter values to default settings, excluding bus communication parameters, <i>parameter groups 15-0* Operating Data</i> and <i>15-3* Alarm Log</i> . The frequency converter is reset during the next power-up. <i>Parameter 14-22 Operation Mode</i> also reverts to the default setting [0] <i>Normal operation</i> .

14-27 Action At Inverter Fault		
Select how the frequency converter acts in the case of overvoltage, overcurrent, short circuit, or grounding errors.		
Option:	Function:	
[0]	Trip	
[1] *	Warning	

14-29 Service Code		
Range:	Function:	
0*	[0 - 0x7FFFFFFF ]	Service use only.

### 3.10.4 14-3\* Current Limit Control

Parameters for configuring the current limit controller, which is activated when the motor current exceeds the preset current limits (see *parameter 4-18 Current Limit*). These parameters are used to reduce torque as quickly as possible without losing control of the motor.

14-30 Current Lim Ctrl, Proportional Gain		
Range:	Function:	
100 %*	[0 - 500 %]	Enter the proportional gain value for the current limit controller. A higher value makes the controller react faster. Excessive value setting leads to controller instability.

14-31 Current Lim Ctrl, Integration Time		
Range:	Function:	
0.020 s*	[0.002 - 2 s]	Control the current limit control integration time. Setting it to a lower value makes it react faster. A setting too low leads to control instability.

14-32 Current Lim Ctrl, Filter Time		
Range:	Function:	
5 ms*	[1 - 100 ms]	Set a time constant for the current limit controller low-pass filter.

### 3.10.5 14-4\* Energy Optimization

Parameters for adjusting the energy optimization level in both variable torque (VT) and automatic energy optimization (AEO) mode.

Automatic energy optimization is only active if *parameter 1-03 Torque Characteristics* is set to [3] *Auto Energy Optim*.

14-40 VT Level		
Range:	Function:	
90 %*	[40 - 90 %]	<p><b>NOTICE</b></p> <p>This parameter cannot be adjusted while the motor is running.</p> <p>Enter the level of motor magnetization at low speed. Low values reduce energy loss in the motor, but also reduce load capability.</p>

14-41 AEO Minimum Magnetisation		
Range:	Function:	
66 %*	[40 - 75 %]	Enter the minimum allowable magnetization for AEO. Low values reduce energy loss in the motor, but also reduce resistance to sudden load changes.

14-44 d-axis current optimization for IPM		
Range:	Function:	
100 %*	[0 - 200 %]	

### 3.10.6 14-5\* Environment

These parameters help the frequency converter to operate under special environmental conditions.

14-50 RFI Filter		
This parameter is only valid for frequency converters of the following enclosure sizes:		
<ul style="list-style-type: none"> <li>• IP20, 3x200–240 V, enclosure sizes H6–H8</li> <li>• IP20, 3x380–480 V, enclosure sizes H6–H8</li> <li>• IP54, 3x380–480 V, enclosure sizes I6–I8</li> <li>• IP20, 3x525–600 V, enclosure sizes H6–H10</li> </ul>		
Option:	Function:	
[0]	Off	Select [0] Off only if the frequency converter is fed by an isolated mains source (IT mains). In this mode, the internal RFI filter capacitors between chassis and the mains RFI filter circuit are cut out to reduce the ground capacity currents.
[1] *	On	Select [1] On to ensure that the frequency converter complies with EMC standards.

14-51 DC-Link Voltage Compensation		
Option:	Function:	
[0]	Off	The overmodulation for output voltage is off to avoid torque ripple on the motor shaft.
[1] *	On	Enables the overmodulation for output voltage to obtain an output voltage up to 15% greater than the mains voltage.

14-52 Fan Control		
This parameter is used to select the fan control operating mode. The acoustic noise of the frequency converter is different from running heavy load (high heat sink temperature) to running light load or stand-by mode.		
Option:	Function:	
[0]	Auto	The fan runs with full speed for a short time and then automatically adjusts the speed according to the load and ambient temperature. The fan also runs at minimum speed even if the reference is 0 Hz due to the heat generated from the IGBT. The fan stops if sleep mode function is activated. This is the default setting for all frequency converters except H1 enclosure sizes.
[4]	Auto Low Temp Env.	Only valid for H6-H10 & I6-I8 enclosure sizes.

14-52 Fan Control		
This parameter is used to select the fan control operating mode. The acoustic noise of the frequency converter is different from running heavy load (high heat sink temperature) to running light load or stand-by mode.		
Option:	Function:	
[5]	Constant-on mode	For on-site fan test or if the fan must run 100% speed constantly. Only valid for H1-H5 & I2-I4 enclosure sizes.
[6]	Constant-off mode	If convection cooling is sufficient or the frequency converter is mounted in a demonstration panel, exhibitions and so on. The frequency converter trips on heat sink overtemperature if loaded more than the convection cooling allows. Only valid for H1-H5 & I2-I4 enclosure sizes.
[7]	On-when-Inverter-is-on-else-off Mode	The fan runs at maximum speed if in hand-on mode or reference is above 0 Hz. The fan is stopped if sleep mode is active. This is the default setting for H1 enclosure size only but can also be selected for H2-H5 & I2-I4 enclosure sizes.

14-53 Fan Monitor		
Select which reaction the frequency converter should take in case a fan fault is detected. This parameter is only valid for frequency converters of the following enclosure sizes:		
<ul style="list-style-type: none"> <li>• IP20, 3x200–240 V, enclosure sizes H6–H8.</li> <li>• IP20, 3x380–480 V, enclosure sizes H6–H8.</li> <li>• IP54, 3x380–480 V, enclosure sizes I6–I8.</li> <li>• IP20, 3x525–600 V, enclosure sizes H6–H10.</li> </ul>		
Option:	Function:	
[0]	Disabled	
[1] *	Warning	
[2]	Trip	

14-55 Output Filter		
Select whether an output filter is present.		
Option:	Function:	
[0] *	No Filter	
[1]	Sine-Wave Filter	
[3]	Sine-Wave Filter with Feedback	
[4]	dv/dt	This option is only valid for the frequency converter of the following enclosure sizes: <ul style="list-style-type: none"> <li>• IP20, 3x200-240 V, enclosure sizes H6-H8</li> <li>• IP20, 3x380-480 V, enclosure sizes H6-H8</li> </ul>

14-55 Output Filter		
Select whether an output filter is present.		
<b>Option:</b>		<b>Function:</b>
		<ul style="list-style-type: none"> <li>IP54, 3x380-480 V, enclosure sizes I6-I8</li> <li>IP20, 3x525-600 V, enclosure sizes H6-H10</li> </ul>

### 3.10.7 14-6\* Auto Derate

Parameter group for configuring automatic derating based on the output frequency of the frequency converter.

14-63 Min Switch Frequency		
Set the minimum switching frequency allowed by the output filter.		
<b>Option:</b>		<b>Function:</b>
[2] *	2.0 kHz	
[3]	3.0 kHz	
[4]	4.0 kHz	
[5]	5.0 kHz	
[6]	6.0 kHz	
[7]	8.0 kHz	
[8]	10.0 kHz	
[9]	12.0 kHz	
[10]	16.0 kHz	

14-64 Dead Time Compensation Zero Current Level		
If a long motor cable is used, set the parameter to [0] Disabled to minimize the motor-torque ripple.		
<b>Option:</b>		<b>Function:</b>
[0] *	Disabled	
[1]	Enabled	

14-65 Speed Derate Dead Time Compensation		
<b>Range:</b>		<b>Function:</b>
Size related*	[ 20 - 1000 Hz]	Dead time compensation level is reduced linearly from the maximum level of the output frequency set in <i>parameter 14-07 Dead Time Compensation Level</i> to the minimum level of the output frequency set in this parameter.

### 3.10.8 14-9\* Fault Settings

The parameter group for fault customization settings.

14-90 Fault Level		
Use this parameter to customize fault levels. Only index 7, which indicates overcurrent faults, is supported.		
<b>Option:</b>		<b>Function:</b>
[3] *	Trip lock	Alarm is set to trip lock level.

14-90 Fault Level		
Use this parameter to customize fault levels. Only index 7, which indicates overcurrent faults, is supported.		
<b>Option:</b>		<b>Function:</b>
[4]	Trip w. delayed reset	Alarm is configured into trip alarm, which can be reset after a delay time. For example, if overcurrent alarm is configured to this option, it can be reset 3 minutes after the alarm is reported.
[5]	Flystart	The frequency converter tries to catch a motor spinning when starting. If this option is selected, <i>parameter 1-73 Flying Start s</i> set to [1] Enabled.

### 3.11 Main Menu - Drive Information - Group 15

Parameter group containing frequency converter information such as operating data, hardware configuration, and software versions.

#### 3.11.1 15-0\* Operating Data

15-00 Operating hours		
<b>Range:</b>		<b>Function:</b>
0 h*	[0 - 0x7ffffff. h]	View how many hours the frequency converter has run. The value is saved when the frequency converter is turned off.

15-01 Running Hours		
<b>Range:</b>		<b>Function:</b>
0 h*	[0 - 0x7ffffff. h]	View how many hours the motor has run. Reset the counter in <i>parameter 15-07 Reset Running Hours Counter</i> . The value is saved when the frequency converter is turned off.

15-02 kWh Counter		
<b>Range:</b>		<b>Function:</b>
0 kWh*	[0 - 65535 kWh]	View the output power of the frequency converter in kWh as a mean value over 1 hour. Reset the counter in <i>parameter 15-06 Reset kWh Counter</i> .

15-03 Power Up's		
<b>Range:</b>		<b>Function:</b>
0*	[0 - 2147483647 ]	View the number of times the frequency converter has been powered up.

15-04 Over Temp's		
Range:		Function:
0*	[0 - 65535 ]	View the number of frequency converter temperature faults that have occurred.

15-05 Over Volt's		
Range:		Function:
0*	[0 - 65535 ]	View the number of frequency converter overvoltages that have occurred.

15-06 Reset kWh Counter		
Option:		Function:
		<b>NOTICE</b> To reset, press [OK].
[0] *	Do not reset	
[1]	Reset counter	To reset the kWh counter to 0, select [1] Reset and press [OK] (see parameter 15-02 kWh Counter).

15-07 Reset Running Hours Counter		
Option:		Function:
[0] *	Do not reset	
[1]	Reset counter	To reset the running hours counter, select [1] Reset counter and press [OK] (parameter 15-01 Running Hours) to 0 (see also parameter 15-01 Running Hours).

### 3.11.2 15-3\* Alarm Log

Parameters in this group are array parameters, where up to 10 fault logs can be viewed. [0] is the most recent logged data, and [9] the oldest. Fault codes, values, and time stamp can be viewed for all logged data.

15-30 Alarm Log: Error Code		
Range:		Function:
0*	[0 - 255 ]	View the fault code and lookup its meaning in <i>chapter 4 Troubleshooting</i> .

15-31 InternalFaultReason		
Range:		Function:
0*	[-32767 - 32767 ]	View a description of the error. This parameter is used with <i>alarm 38, Internal Fault</i> .

### 3.11.3 15-4\* Drive Identification

Parameters containing read-only information about the hardware and software configuration of the frequency converter.

15-40 FC Type		
Range:		Function:
0*	[0 - 6 ]	View the FC type code. The readout is identical to the frequency converter series power field of the type code definition, characters 1–6.

15-41 Power Section		
Range:		Function:
0*	[0 - 20 ]	View the FC type code. The readout is identical to the frequency converter series power field of the type code definition, characters 7–10.

15-42 Voltage		
Range:		Function:
0*	[0 - 20 ]	View the FC type code. The readout is identical to the frequency converter series power field of the type code definition, characters 11–12.

15-43 Software Version		
Range:		Function:
0*	[0 - 0 ]	View the software version of the frequency converter.

15-44 Ordered TypeCode		
Range:		Function:
0*	[0 - 40 ]	View the type code string used for reordering the frequency converter in its original configuration.

15-45 Actual Typecode String		
Range:		Function:
0	[0 - 40 ]	View the actual type code string.

15-46 Drive Ordering No		
Range:		Function:
0*	[0 - 8 ]	View the 8-digit ordering number for reordering the frequency converter in its original configuration.

15-48 LCP Id No		
Range:		Function:
0*	[0 - 0 ]	View the keypad ID number.



15-49 SW ID Control Card		
Range:	Function:	
0*	[0 - 0 ]	View the control card software version number.

15-50 SW ID Power Card		
Range:	Function:	
0*	[0 - 0 ]	View the power card software version number.

15-51 Drive Serial Number		
Range:	Function:	
0*	[0 - 10 ]	View the frequency converter serial number.

15-53 Power Card Serial Number		
Range:	Function:	
0*	[0 - 0 ]	View the power card serial number.

15-59 Filename		
Range:	Function:	
0	[0 - 16 ]	View the current CSIV file name.

### 3.12 Main Menu - Data Readouts - Group 16

#### 3.12.1 16-0\* General Status

16-00 Control Word		
Range:	Function:	
0*	[0 - 65535 ]	View the control word sent from the frequency converter via the serial communication port in hex code.

Bit	Bit = 0	Bit = 1
00	Preset reference option lsb	-
01	Preset reference option 2 <sup>nd</sup> bit of preset references	-
02	DC brake	Ramp
03	Coasting	Enable
04	Quick stop	Ramp
05	Freeze output	Ramp
06	Ramp stop	Start
07	No function	Reset
08	No function	Jog
09	Ramp 1	Ramp 2
10	Data not valid	Valid
11	Relay_A not active	Relay_A activated
12	Relay_B not active	Relay_B activated
13	Choice of set-up lsb	-
14	No function	No function
15	No function	Reversing

Table 3.6 Control Word

16-01 Reference [Unit]		
Range:	Function:	
0 ReferenceFeedback Unit*	[-4999 - 4999 Reference-FeedbackUnit]	View the present reference value applied on impulse or analog basis in the unit resulting from the configuration selected in <i>parameter 1-00 Configuration Mode</i> (Hz).

16-02 Reference [%]		
Range:	Function:	
0 %*	[-200 - 200 %]	View the total reference. The total reference is the sum of digital, analog, preset, bus, and freeze references.

16-03 Status Word		
Range:	Function:	
0*	[0 - 65535 ]	View the status word sent from the frequency converter via the serial communication port in hex code.

Bit	Bit = 0	Bit = 1
00	Control not ready	Ready
01	Drive not ready	Ready
02	Coasting	Enable
03	No fault	Trip
04	No warning	Warning
05	Reserved	-
06	No trip lock	Trip lock
07	No warning	Warning
08	Speed ≠ ref.	Speed = ref.
09	Local control	Bus control
10	Out of range	Frequency OK
11	Not running	Running
12	No function	No function
13	Voltage OK	Above limit
14	Current OK	Above limit
15	Thermal-level OK	Above limit

Table 3.7 Status Word

16-05 Main Actual Value [%]		
Range:	Function:	
0 %*	[-200 - 200 %]	View the 2 byte word sent with the status word to the bus master reporting the main actual value.

16-09 Custom Readout		
Range:	Function:	
0 Custom-ReadoutUnit*	[0 - 9999 CustomReadoutUnit]	View the user-defined readouts as defined in <i>parameter 0-30 Custom Readout Unit</i> , <i>parameter 0-31 Custom Readout Min</i>

16-09 Custom Readout		
Range:		Function:
		Value, and parameter 0-32 Custom Readout Max Value.

### 3.12.2 16-1\* Motor Status

16-10 Power [kW]		
Range:		Function:
0 kW*	[0 - 1000 kW]	Displays the actual motor power in kW. The value shown is calculated on the basis of the actual motor voltage and motor current.

16-11 Power [hp]		
Range:		Function:
0 hp*	[0 - 1000 hp]	View the actual motor power in hp. The value shown is calculated based on the actual motor voltage and motor current.

16-12 Motor Voltage		
Range:		Function:
0 V*	[0 - 65535 V]	View the motor voltage, a calculated value used for controlling the motor.

16-13 Frequency		
Range:		Function:
0 Hz*	[0 - 6553.5 Hz]	View the motor frequency, without resonance damping.

16-14 Motor current		
Range:		Function:
0 A*	[0 - 655.35 A]	View the motor current measured as an average value, $I_{RMS}$ .

16-15 Frequency [%]		
Range:		Function:
0 %*	[0 - 6553.5 %]	View a 2-byte word reporting the actual motor frequency (without resonance damping) as a percentage (scale 0000–4000 hex) of parameter 4-19 Max Output Frequency.

16-16 Torque [Nm]		
Range:		Function:
0 Nm*	[-30000 - 30000 Nm]	View the torque value that is applied on the motor shaft. Some motors supply more than 160% torque. Consequently, the minimum value and the maximum value

16-16 Torque [Nm]		
Range:		Function:
		depend on the minimum/maximum motor current as well as the motor used.

16-17 Speed [RPM]		
Range:		Function:
0 RPM*	[-30000 - 30000 RPM]	View the actual motor RPM. The motor RPM is estimated in open-loop process or closed-loop process control modes and the motor RPM is measured in speed closed-loop mode.

16-18 Motor Thermal		
Range:		Function:
0 %*	[0 - 100 %]	View the calculated motor temperature in percentage of allowed maximum. At 100%, a trip occurs if selected in parameter 1-90 Motor Thermal Protection. The basis for the calculation is the ETR function selected in parameter 1-90 Motor Thermal Protection.

16-22 Torque [%]		
Range:		Function:
0 %*	[-200 - 200 %]	View the torque in percentage (in relation to the nominal torque) that is applied to the motor shaft.

### 3.12.3 16-3\* Drive Status

16-30 DC Link Voltage		
Range:		Function:
0 V*	[0 - 65535 V]	Shows the actual DC-link voltage.

16-34 Heatsink Temp.		
Range:		Function:
0 °C*	[-128 - 127 °C]	View the heat sink temperature of the frequency converter.

16-35 Inverter Thermal		
Range:		Function:
0 %*	[0 - 255 %]	View the percentage of thermal load on the frequency converter. At 100%, a trip occurs.

16-36 Inv. Nom. Current		
Range:		Function:
0 A*	[0 - 655.35 A]	View the inverter nominal current. The data is used for motor overload protection and so on.

16-37 Inv. Max. Current		
Range:		Function:
0 A*	[0 - 655.35 A]	View the inverter maximum current. The data is used for calculation of frequency converter protection and so on.

16-38 SL Controller State		
Range:		Function:
0*	[0 - 20 ]	View the actual state of the smart logic controller (SLC).

### 3.12.4 16-5\* Ref. & Feedb.

16-50 External Reference		
Range:		Function:
0 %*	[-200 - 200 %]	View the total reference, the sum of digital, analog, preset, bus, and freeze references.

16-52 Feedback[Unit]		
Range:		Function:
0 ProcessCtrl Unit*	[-4999 - 4999 ProcessCtrlUnit]	View the feedback resulting from the selection of scaling in <i>parameter 3-02 Minimum Reference</i> and <i>parameter 3-03 Maximum Reference</i> .

16-54 Feedback 1 [Unit]		
Range:		Function:
0 ProcessCtrl Unit*	[-999999.999 - 999999.999 ProcessCtrlUnit]	View the feedback 1 value resulting from the selection of scaling in <i>parameter 3-02 Minimum Reference</i> and <i>parameter 3-03 Maximum Reference</i> .

16-55 Feedback 2 [Unit]		
Range:		Function:
0 ProcessCtrl Unit*	[-999999.999 - 999999.999 ProcessCtrlUnit]	View the feedback 2 value resulting from the selection of scaling in <i>parameter 3-02 Minimum Reference</i> and <i>parameter 3-03 Maximum Reference</i> .

### 3.12.5 16-6\* Inputs and Outputs

16-60 Digital Input																
Range:		Function:														
0*	[0 - 4095 ]	View actual state of the digital inputs 18, 19, 27, and 29.														
		<table border="1"> <tr><td>Bit 0</td><td>Unused</td></tr> <tr><td>Bit 1</td><td>Unused</td></tr> <tr><td>Bit 2</td><td>Digital input terminal 29</td></tr> <tr><td>Bit 3</td><td>Digital input terminal 27</td></tr> <tr><td>Bit 4</td><td>Digital input terminal 19</td></tr> <tr><td>Bit 5</td><td>Digital input terminal 18</td></tr> <tr><td>Bit 6-15</td><td>Unused</td></tr> </table>	Bit 0	Unused	Bit 1	Unused	Bit 2	Digital input terminal 29	Bit 3	Digital input terminal 27	Bit 4	Digital input terminal 19	Bit 5	Digital input terminal 18	Bit 6-15	Unused
Bit 0	Unused															
Bit 1	Unused															
Bit 2	Digital input terminal 29															
Bit 3	Digital input terminal 27															
Bit 4	Digital input terminal 19															
Bit 5	Digital input terminal 18															
Bit 6-15	Unused															
<b>Table 3.8 Bits Definition</b>																

16-61 Terminal 53 Setting		
View the setting of input terminal 53.		
<ul style="list-style-type: none"> <li>Current = 0</li> <li>Voltage = 1</li> </ul>		
<b>Option:</b>	<b>Function:</b>	
[0] *	Current mode	
[1]	Voltage mode	

16-62 Analog input 53		
Range:		Function:
1*	[0 - 20 ]	View the actual value at input 53.

16-63 Terminal 54 Setting		
View the setting of input terminal 54.		
<ul style="list-style-type: none"> <li>Current = 0</li> <li>Voltage = 1</li> </ul>		
<b>Option:</b>	<b>Function:</b>	
[0] *	Current mode	
[1]	Voltage mode	

16-64 Analog input 54		
Range:		Function:
1*	[0 - 20 ]	View the actual value at input 54.

16-65 Analog output 42 [mA]		
Range:		Function:
0 mA*	[0 - 20 mA]	View the actual value at output 42 in mA. The value shown reflects the selection in <i>parameter 6-90 Terminal 42 Mode</i> and <i>parameter 6-91 Terminal 42 Analog Output</i> .

16-66 Digital Output		
Range:	Function:	
0*	[0 - 15 ]	View the binary value of all digital outputs.  <b>Definition:</b> X: Not used 0: Low 1: High
	<b>XX</b>	<b>None used</b>
	X0	Terminal 42 not used, terminal 45 low.
	X1	Terminal 42 not used, terminal 45 high.
	0X	Terminal 42 low, terminal 45 not used.
	0	Terminal 42 low, terminal 45 low.
	1	Terminal 42 low, terminal 45 high.
	1X	Terminal 42 high, terminal 45 not used.
	10	Terminal 42 high, terminal 45 low.
	11	Terminal 42 high, terminal 45 high.
<b>Table 3.9 Binary Value of Digital Outputs</b>		

16-67 Pulse Input #29 [Hz]		
Range:	Function:	
0 *	[0 - 130000 ]	View the actual frequency rate on terminal 29.

16-71 Relay output		
Range:	Function:	
0*	[0 - 31 ]	View the setting of the relay.
	Bit 0~2	Unused
	Bit 3	Relay 02
	Bit 4	Relay 01
	Bit 5~15	Unused
<b>Table 3.10 Bits Definition</b>		

16-72 Counter A		
Range:	Function:	
0*	[-32768 - 32767 ]	View the present value of counter A. Counters are useful as comparator operands, see <i>parameter 13-10 Comparator Operand</i> . The value can be reset or changed either via digital inputs ( <i>parameter</i>

16-72 Counter A		
Range:	Function:	
		<i>group 5-1* Digital Inputs</i> ) or by using an SLC action ( <i>parameter 13-52 SL Controller Action</i> ).

16-73 Counter B		
Range:	Function:	
0*	[-32768 - 32767 ]	View the present value of counter B. Counters are useful as comparator operands ( <i>parameter 13-10 Comparator Operand</i> ). The value can be reset or changed either via digital inputs ( <i>parameter group 5-1* Digital Inputs</i> ) or by using an SLC action ( <i>parameter 13-52 SL Controller Action</i> ).

16-79 Analog output 45 [mA]		
Range:	Function:	
0 mA*	[0 - 20 mA]	View the actual value at output 45 in mA. The value shown reflects the selection in <i>parameter 6-70 Terminal 45 Mode</i> and <i>parameter 6-71 Terminal 45 Analog Output</i> .

### 3.12.6 16-8\* Fieldbus & FC Port

Parameters for reporting the bus references and control words.

16-86 FC Port REF 1		
Range:	Function:	
0*	[-32768 - 32767 ]	View the last received reference from the FC port.

### 3.12.7 16-9\* Diagnosis Read-Outs

16-90 Alarm Word		
Range:	Function:	
0*	[0 - 0xFFFFFFFFFUL ]	View the alarm word sent via the serial communication port in hex code.

16-91 Alarm Word 2		
Range:	Function:	
0*	[0 - 0xFFFFFFFFFUL ]	View the alarm word 2 sent via the serial communication port in hex code.

16-92 Warning Word		
Range:	Function:	
0*	[0 - 0xFFFFFFFFFUL ]	View the warning word sent via the serial communication port in hex code.

16-93 Warning Word 2		
Range:	Function:	
0*	[0 - 0xFFFFFFFFFUL ]	View the warning word 2 sent via the serial communication port in hex code.

16-94 Ext. Status Word		
Range:	Function:	
0*	[0 - 0xFFFFFFFFFUL ]	Shows the extended status word sent via the serial communication port in hex code.

16-95 Ext. Status Word 2		
Range:	Function:	
0*	[0 - 0xFFFFFFFFFUL ]	Shows the extended status word 2 sent via the serial communication port in hex code.

16-97 Alarm Word 3		
Range:	Function:	
0*	[0 - 4294967295]	View the alarm word 3 sent via the serial communication port in hex code.

16-98 Warning Word 3		
Range:	Function:	
0*	[0 - 4294967295]	View the warning word 3 sent via the serial communication port in hex code.

### 3.13 Main Menu - Data Readouts 2 - Group 18

Parameters in this group are array parameters, where up to 10 fault logs can be viewed. [0] is the most recent logged data, and [9] is the oldest. Fault codes, values, and time stamp can be viewed for all logged data.

#### 3.13.1 18-1\* Fire Mode Log

18-10 FireMode Log:Event		
Range:	Function:	
0*	[0 - 255 ]	View fire mode event.

#### 3.13.2 18-5\* Ref. & Feedb.

18-50 Sensorless Readout [unit]		
Range:	Function:	
0 SensorlessUnit*	[-999999.999 - 999999.999 SensorlessUnit]	View the pressure or flow resulting from the sensorless calculations. This value is not the value used for control. The value is only updated if sensorless data supports both flow and pressure.

### 3.14 Main Menu - FC Closed Loop - Group 20

This parameter group is used for configuring the closed-loop PI controller that controls the output frequency of the frequency converter.

#### 3.14.1 20-0\* Feedback

This parameter group is used to configure the feedback signal for the closed-loop PI control of the frequency converter.

20-00 Feedback 1 Source		
Option:	Function:	
		This parameter defines which input is used as the source of the feedback signal.
[0] *	No function	
[1]	Analog Input 53	
[2]	Analog Input 54	
[3]	Pulse input 29	
[100]	Bus Feedback 1	
[101]	Bus Feedback 2	
[104]	Sensorless Flow	
[105]	Sensorless Pressure	

20-01 Feedback 1 Conversion		
Option:	Function:	
		This parameter allows a conversion function to be applied to feedback 1.
[0] *	Linear	[0] Linear has no effect on the feedback.
[1]	Square root	[1] Square root is commonly used when a pressure sensor is used to provide flow feedback. $((flow \propto \sqrt{pressure}))$ .

20-03 Feedback 2 Source		
Option:	Function:	
[0] *	No function	
[1]	Analog Input 53	

20-03 Feedback 2 Source		
Option:	Function:	
[2]	Analog Input 54	
[3]	Pulse input 29	
[100]	Bus Feedback 1	
[101]	Bus Feedback 2	

20-04 Feedback 2 Conversion		
Option:	Function:	
[0] *	Linear	
[1]	Square root	

20-12 Reference/Feedback Unit		
Option:	Function:	
		Select the unit to be used with references and feedbacks for closed loop.
[0] *	None Expressionlimit	
[20]	l/s	
[23]	m3/s	
[24]	m3/min	
[25]	m3/h	
[71]	bar	
[73]	kPa	
[74]	m Wg	
[75]	mm Hg	
[120]	GPM	
[121]	gal/s	
[122]	gal/min	
[123]	gal/h	
[124]	CFM	
[125]	ft <sup>3</sup> /s	
[126]	ft <sup>3</sup> /min	
[170]	psi	
[171]	lb/in2	
[172]	in WG	
[173]	ft WG	
[174]	in Hg	

### 3.14.2 20-2\* Feedback/Setpoint

Parameter group for feedback function and setpoints. Select which setpoint and feedback to use. The setpoint and feedback can be a fixed pair or selected separately based on logic comparisons.

20-20 Feedback Function		
Option:	Function:	
[0]	Sum	

20-20 Feedback Function		
Option:	Function:	
[1]	Difference	
[2]	Average	
[3] *	Minimum	
[4]	Maximum	

### 3.14.3 20-6\* Sensorless

Parameters for sensorless. See also *parameter 16-26 Power Filtered [kW]*, *parameter 16-27 Power Filtered [hp]*, *parameter 18-50 Sensorless Readout [unit]*, and *parameter 20-00 Feedback 1 Source*.

20-60 Sensorless Unit		
Option:	Function:	
		Select the unit to be used with <i>parameter 18-50 Sensorless Readout [unit]</i> .
[0]	None	
[20] *	l/s Expressionlimit	
[23]	m3/s	
[24]	m3/min	
[25]	m3/h	
[71]	bar	
[73]	kPa	
[74]	m Wg	
[75]	mm Hg	
[120]	GPM	
[121]	gal/s	
[122]	gal/min	
[123]	gal/h	
[124]	CFM	
[125]	ft <sup>3</sup> /s	
[126]	ft <sup>3</sup> /min	
[170]	psi	
[171]	lb/in2	
[172]	in WG	
[173]	ft WG	
[174]	in Hg	

20-69 Sensorless Information		
Range:	Function:	
0*	[0 - 25 ]	View information about the sensorless data.

### 3.14.4 20-7\* PI Auto-tuning

Parameters for enabling PI auto-tuning.

20-70 Closed Loop Type		
Option:	Function:	
		Select the expected application response.
[0] *	Auto	
[1]	Fast Pressure	
[2]	Slow Pressure	
[3]	Fast Temperature	
[4]	Slow Temperature	

20-71 PI Performance		
Option:	Function:	
		Select the relative response speed for the application.
[0] *	Normal	
[1]	Fast	

20-72 PI Output Change		
Range:	Function:	
0.10*	[0.01 - 0.50 ]	Set the magnitude of step change during the auto-tuning sequence.

20-73 Minimum Feedback Level		
Range:	Function:	
-4999.000*	[-4999.000 - Expressionlimit (4999.000)]	Set the minimum allowable feedback value during the auto-tuning sequence.

20-74 Maximum Feedback Level		
Range:	Function:	
4999.000*	[Expressionlimit (-4999.000) - 4999.000]	Set the maximum allowable feedback value during the auto-tuning sequence.

20-79 PI Autotuning		
Option:	Function:	
[0] *	Disabled	Select to disable PI auto-tuning.
[1]	Enabled	Select to enable PI auto-tuning.

### 3.14.5 20-8\* PI Basic Settings

Parameters for configuring the process PI control.

20-81 PI Normal/ Inverse Control		
Option:	Function:	
[0] *	Normal	Causes the frequency converter output frequency to decrease when the feedback is greater than the setpoint reference. This behavior is

20-81 PI Normal/ Inverse Control		
Option:	Function:	
		common for pressure-controlled supply fan and pump applications.
[1]	Inverse	Causes the frequency converter output frequency to increase when the feedback is greater than the setpoint reference. This behavior is common for temperature-controlled cooling applications, such as cooling towers.

20-83 PI Start Speed [Hz]		
Range:	Function:	
0 Hz*	[ 0 - 200.0 Hz]	Enter the motor speed to be attained as a start signal for commencement of PI control. After power-up, the frequency converter operates using speed open-loop control. When the process PI start speed is reached, the frequency converter changes to PI control.

20-84 On Reference Bandwidth		
Range:	Function:	
5 %*	[0 - 200 %]	When the difference between the feedback and the setpoint reference is less than the value of this parameter, the frequency converter display shows <i>Run on Reference</i> . This status can be communicated externally by programming the function of a digital output for [8] <i>Run on Reference/No Warning</i> . In addition, for serial communications, the on-reference status bit of the frequency converter status word is high (1). The on-reference bandwidth is calculated as a percentage of the setpoint reference.

### 3.14.6 20-9\* PI Controller

20-91 PI Anti Windup		
Option:	Function:	
[0]	Off	Continue regulation of an error even when the output frequency cannot be increased or decreased.
[1] *	On	Cease regulation of an error when the output frequency can no longer be adjusted.

20-93 PI Proportional Gain		
Range:		Function:
0.50*	[0 - 10 ]	Enter the process controller proportional gain. Quick control is obtained at high amplification. However, if amplification is too high, the process may become unstable.

20-94 PI Integral Time		
Range:		Function:
20 s*	[0.10 - 9999 s]	Enter the process controller integral time. Obtain quick control through a short integral time, though if the integral time is too short, the process becomes unstable. An excessively long integral time disables the integral action.

20-97 PI Feed Forward Factor		
Range:		Function:
0 %*	[0 - 400 %]	Enter the PI feed forward factor. The FF factor sends a constant fraction of the reference signal to bypass PI control. Therefore, the PI can affect only the remaining fraction of the control signal. The FF factor can increase dynamic performance.

### 3.15 Main Menu - Application Functions - Group 22

#### 3.15.1 22-0\* Miscellaneous

Parameter group for extra settings.

22-01 Power Filter Time		
Range:		Function:
0.50 s*	[0.02 - 10 s]	Set the time constant for the filtered power readout. A higher value gives a more steady readout but a slower system response to changes.

22-02 Sleepmode CL Control Mode		
Option:	Function:	
[0]	Normal	The feedback is detected. Some parameters are checked.
[1]	Simplified	The feedback is not detected. Only sleep speed and time are checked.

This parameter is for sleep mode running in process closed-loop mode. Use this parameter to configure whether to detect the feedback for sleep mode.



## 3.15.2 22-2\* No-Flow Detection

3

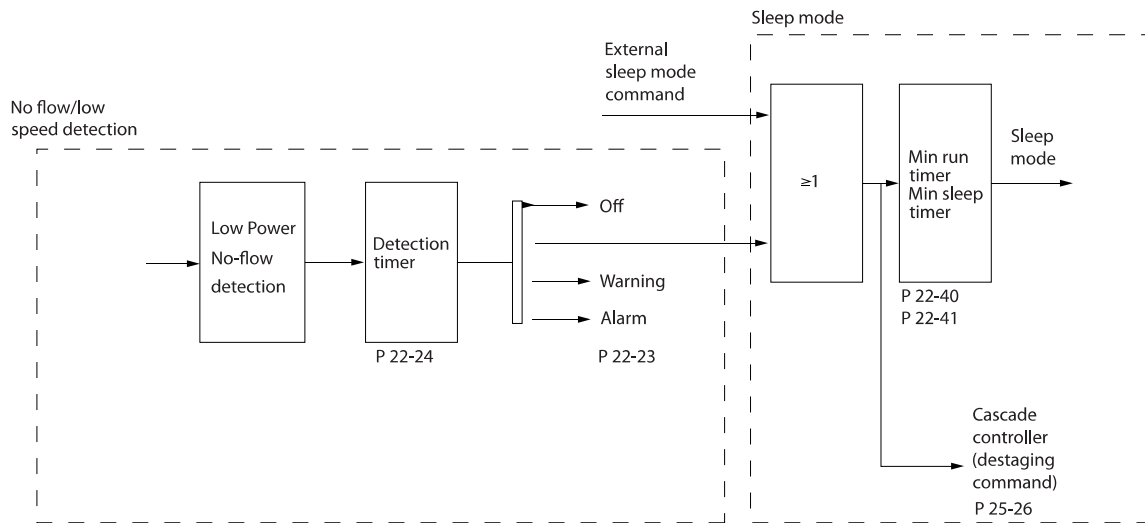

130BE841.10

Illustration 3.16 No-flow Detection

The frequency converter includes functions for detecting if the load conditions in the system allow the motor to be stopped:

- Low power detection.

One of these 2 signals must be active for a set time (*parameter 22-24 No-Flow Delay*) before selected action takes place. Possible actions to select (*parameter 22-23 No-Flow Function*):

- No action
- Warning
- Alarm
- Sleep mode

**No-flow detection**

This function is used for detecting a no-flow situation in pump systems where all valves can be closed. Can be used both when controlled by the integrated PI controller in the frequency converter or an external PI controller. Program the actual configuration in *parameter 1-00 Configuration Mode*.

Configuration mode for

- Integrated PI controller: Closed loop.
- External PI controller: Open loop.

**NOTICE**

Carry out no-flow tuning before setting the PI controller parameters.

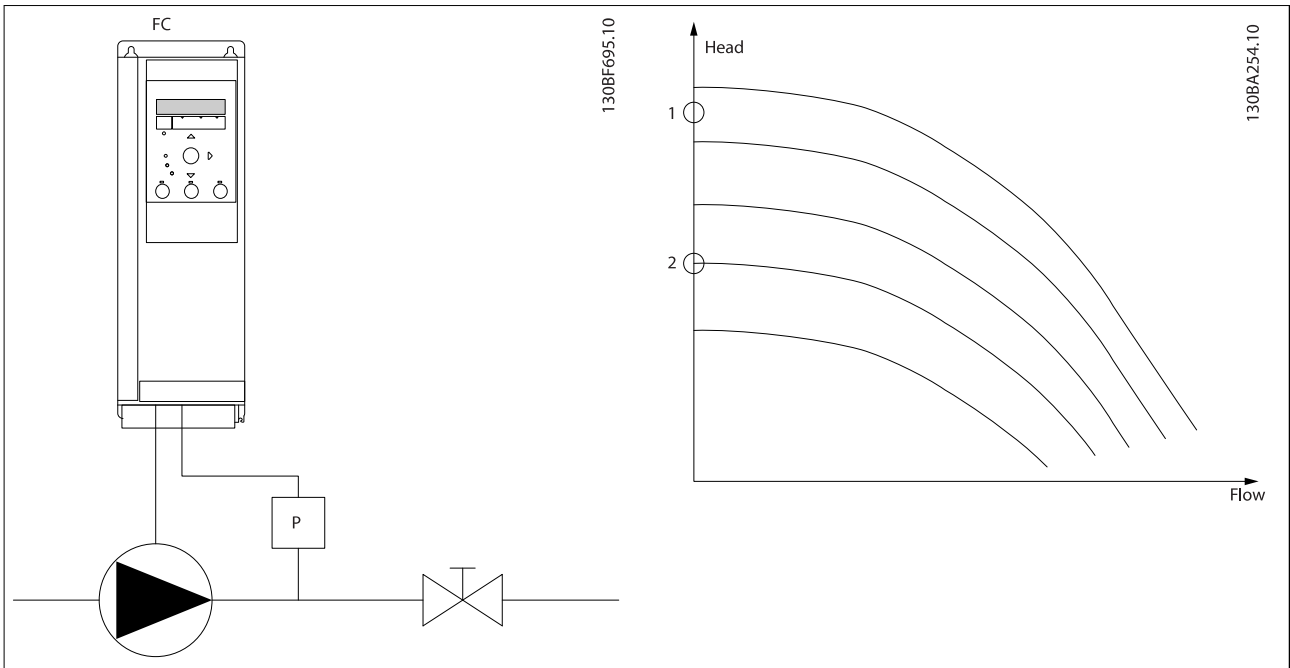

3

**Table 3.11 No-flow Detection**

No-flow detection is based on the measurement of speed and power. For a certain speed, the frequency converter calculates the power at no-flow.

This coherence is based on the adjustment of 2 sets of speed and associated power at no-flow. Monitoring power enables detection of no-flow conditions in systems with fluctuating suction pressure, or of the pump having a flat characteristic towards low speed.

22-23 No-Flow Function		
Option:	Function:	
[0] *	Off	
[1]	Sleep Mode	
[2]	Warning	
[3]	Alarm	

22-24 No-Flow Delay		
Range:	Function:	
10 s*	[1 - 600 s]	

### 3.15.3 22-3\* No-flow Power Tuning

Tuning sequence:

- To stop flow, close the main valve.
- Run with motor until the system has reached normal operating temperature.
- Press the [Hand On] key on the keypad and adjust speed for approximately 85% of the rated speed. Note the exact speed.
- Read power consumption either by looking for actual power in the data line in the keypad or call *parameter 16-10 Power [kW]* in the Main Menu. Note the power readout.
- Change speed to approximately 50% of the rated speed. Note the exact speed.
- Read power consumption either by looking for actual power in the data line in the keypad or call *parameter 16-10 Power [kW]* in the Main Menu. Note the power readout.
- Program the speeds used in *parameter 22-33 Low Speed [Hz]* and *parameter 22-37 High Speed [Hz]*.
- Program the associated power values in *parameter 22-34 Low Speed Power [kW]* and *parameter 22-38 High Speed Power [kW]*.
- Switch back pressing [Auto On] or [Off].

#### **NOTICE**

Set *parameter 1-03 Torque Characteristics* before tuning takes place.

22-30 No-Flow Power		
Range:	Function:	
0 kW*	[0 - 1000 kW]	Readout of calculated no-flow power at actual speed.

22-31 Power Correction Factor		
Range:	Function:	
100 %*	[1 - 400 %]	Set a correction if no-flow detection reacts on a too low or too high power value.

22-33 Low Speed [Hz]		
Range:	Function:	
0 Hz*	[0 - 400 Hz]	Set output speed used for registration of no-flow power at low speed.

22-34 Low Speed Power [kW]		
Range:	Function:	
0 kW*	[0 - 5.50 kW]	Set no-flow power at low speed.

22-37 High Speed [Hz]		
Range:	Function:	
0 Hz*	[0 - 400 Hz]	Set output speed used for registration of no-flow power at high speed.

22-38 High Speed Power [kW]		
Range:	Function:	
0 kW*	[0 - 5.50 kW]	Set no-flow power at high speed.

### 3.15.4 22-4\* Sleep Mode

Sleep mode allows the frequency converter to stop itself in situations where the system is in balance. This function saves energy and prevents excessive pressure, water excessively cooled in cooling towers, and building pressurization problems in the system. This is also important as some applications prevent the frequency converter from adjusting the motor down to low speed. This might damage pumps, cause insufficient lubrication in gearboxes, and make fans unstable.

The sleep controller has 2 important functions:

1. The ability to go to sleep at the right time.
2. The ability to abandon sleep mode at the right time.

The goal is to keep the frequency converter in sleep mode as long as possible to avoid cycling the motor on and off frequently, and also keep the controlled system variable within the acceptable range.

#### The sequence when running sleep mode in open loop:

1. The motor speed is less than the speed set in *parameter 22-47 Sleep Speed [Hz]*. The motor runs longer than the time duration set in *parameter 22-40 Minimum Run Time*. The sleep condition lasts longer than the time set in *parameter 22-48 Sleep Delay Time*.
2. The frequency converter ramps the motor speed down to *parameter 1-82 Min Speed for Function at Stop [Hz]*.
3. The frequency converter activates *parameter 1-80 Function at Stop*. The frequency converter is now in sleep mode.
4. The frequency converter compares the speed setpoint with *parameter 22-43 Wake-Up Speed [Hz]* to detect a wake-up situation.
5. The speed setpoint is greater than *parameter 22-43 Wake-Up Speed [Hz]*. The sleep condition has lasted longer than the time set in *parameter 22-41 Minimum Sleep Time*. The wake-up condition lasts longer than the time set in *parameter 22-49 Wake-Up Delay Time*. The frequency converter is now out of sleep mode.
6. Go back to speed open-loop control (ramp motor speed up to the speed setpoint).

#### The sequence when running sleep mode in closed loop:

1. The frequency converter goes into boost status if the following conditions are met.
  - 1a If *parameter 22-02 Sleepmode CL Control Mode* is set to [0] Normal:
    - a. The motor speed is less than the value in *parameter 22-47 Sleep Speed [Hz]*.
    - b. The feedback is above the reference.
    - c. The motor runs longer than the time in *parameter 22-40 Minimum Run Time*.
    - d. The sleep condition lasts longer than the time in *parameter 22-48 Sleep Delay Time*.
  - 1b If *parameter 22-02 Sleepmode CL Control Mode* is set to [1] Simplified:
    - a. The motor speed is less than the value in *parameter 22-47 Sleep Speed [Hz]*.
    - b. The motor runs longer than the time in *parameter 22-40 Minimum Run Time*.
    - c. The sleep condition lasts longer than the time in *parameter 22-48 Sleep Delay Time*.

If *parameter 22-45 Setpoint Boost* is not set, the frequency converter goes into sleep mode.
2. After the time in *parameter 22-46 Maximum Boost Time* has passed, the frequency converter ramps down the motor speed to the speed in *parameter 1-82 Min Speed for Function at Stop [Hz]*.
3. The frequency converter activates *parameter 1-80 Function at Stop*. The frequency converter is now in sleep mode.
4. The frequency converter is out of sleep mode when:

- 4a the error between the reference and the feedback is greater than *parameter 22-44 Wake-Up Ref./FB Diff*, and
  - 4b the sleep time is longer than the time in *parameter 22-41 Minimum Sleep Time*, and
  - 4c the wake-up condition lasts longer than the time set in *parameter 22-48 Sleep Delay Time*.
5. The frequency converter goes back to closed-loop control.

### NOTICE

Sleep mode is not active when local reference is active (set speed manually using the navigation keys on the keypad). Sleep mode does not work in local mode. Perform an auto set-up in open loop before setting input/output in closed loop.

22-40 Minimum Run Time		
Range:		Function:
10 s*	[0 - 600 s]	Set the wanted minimum running time for the motor after a start command (digital input or bus) before entering sleep mode.

22-41 Minimum Sleep Time		
Range:		Function:
10 s*	[0 - 600 s]	Set the minimum time for staying in sleep mode. This time overrides any wake-up conditions.

22-43 Wake-Up Speed [Hz]		
Range:		Function:
10*	[0 - 400.0]	<p>Only to be used if <i>parameter 1-00 Configuration Mode</i> is set to [0] <i>Open loop</i>, and an external controller applies speed reference. Set the reference speed at which the sleep mode should be deactivated.</p> <p>The wake-up speed must not exceed the setting in <i>parameter 4-14 Motor Speed High Limit [Hz]</i>.</p>

22-44 Wake-Up Ref./FB Diff		
Range:		Function:
10 %*	[0 - 100 %]	<p>Only to be used if <i>parameter 1-00 Configuration Mode</i> is set for closed loop and the integrated PI controller is used for controlling the pressure.</p> <p>Set the pressure drop allowed in percentage of setpoint for the pressure (<math>P_{set}</math>) before canceling the sleep mode.</p>

22-45 Setpoint Boost		
Range:		Function:
0 %*	[-100 - 100 %]	<p>Only to be used if <i>parameter 1-00 Configuration Mode</i> is set for closed loop and the integrated PI controller is used. In systems with for example constant pressure control, it is advantageous to increase the system pressure before the motor is stopped. This increase extends the time the motor is stopped and helps to avoid frequent start/stop.</p> <p>Set the required overpressure/ overtemperature in percentage of setpoint for the pressure (<math>P_{set}</math>)/ temperature before entering the sleep mode.</p> <p>If setting for 5%, the boost pressure is <math>P_{set} \times 1.05</math>. The negative values can be used for cooling tower control where a negative change is needed.</p>

22-46 Maximum Boost Time		
Range:		Function:
60 s*	[0 - 600 s]	<p>Only to be used if <i>parameter 1-00 Configuration Mode</i> is set for [3] <i>Closed loop</i> and the integrated PI controller is used for controlling the pressure.</p> <p>Set the maximum time for which boost mode is allowed. If the set time is exceeded, the frequency converter enters the sleep mode without waiting for the set boost pressure to be reached.</p>

22-47 Sleep Speed [Hz]		
Range:		Function:
0*	[0 - 400.0]	Set the speed below which the frequency converter goes into sleep mode.

22-48 Sleep Delay Time		
Range:		Function:
0 s	[0 - 3600 s]	Set the delay time that the motor waits before entering sleep mode when the condition to enter sleep mode is met.

22-49 Wake-Up Delay Time		
Range:		Function:
0 s	[0 - 3600 s]	Set the delay time that the motor waits before waking up from sleep mode when the condition for wake-up is met.

### 3.15.5 22-6\* Broken-belt Detection

Use broken-belt detection in both closed-loop systems and open-loop systems for pumps and fans. If the estimated motor torque (current) is below the broken-belt torque (current) value (*parameter 22-61 Broken Belt Torque*), and the frequency converter output frequency is above or equal to 15 Hz, *parameter 22-60 Broken Belt Function* is performed.

22-60 Broken Belt Function		
Selects the action to be performed if the broken-belt condition is detected.		
Option:	Function:	
[0] *	Off	
[1]	Warning	The frequency converter continues to run, but activates a broken-belt warning, <i>warning 95, Broken Belt</i> . A frequency converter digital output or a serial communication bus can communicate a warning to other equipment.
[2]	Trip	The frequency converter stops running and activates a broken-belt alarm, <i>alarm 95, Broken Belt</i> . A frequency converter digital output or a serial communication bus can communicate an alarm to other equipment.

#### NOTICE

Do not set *parameter 14-20 Reset Mode* to [13] *Infinite auto reset*, when *parameter 22-60 Broken Belt Function* is set to [2] *Trip*. Doing so causes the frequency converter to continuously cycle between running and stopping when a broken-belt condition is detected.

#### NOTICE

If the automatic bypass function is enabled, the bypass starts when the frequency converter experiences a persistent alarm condition. In this case, disable the automatic bypass function if [2] *Trip* is selected as the broken-belt function.

22-61 Broken Belt Torque		
Range:		Function:
10 %*	[5 - 100 %]	Set the broken-belt torque as a percentage of the rated motor torque.

22-62 Broken Belt Delay		
Range:		Function:
10 s*	[0 - 600 s]	Sets the time for which the broken-belt conditions must be active before carrying out the action selected in <i>parameter 22-60 Broken Belt Function</i> .

### 3.15.6 22-8\* Flow Compensation

In certain applications, it is not possible for a pressure transducer to be placed at a remote point in the system, and it can only be placed close to the fan/pump outlet. Flow compensation operates by adjusting the setpoint according to the output frequency, which is almost proportional to flow. Thus, it compensates for higher losses at higher flow rates.

$H_{DESIGN}$  (required pressure) is the setpoint for closed-loop (PI) operation of the frequency converter and is set as for closed-loop operation without flow compensation.

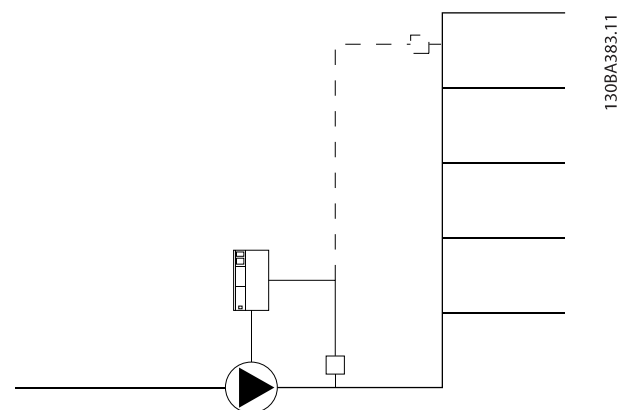

Illustration 3.17 Flow Compensation Set-up

There are 2 methods which can be employed, depending on whether the speed at system design working point is known.

Parameter used	Speed at design point KNOWN	Speed at design point UNKNOWN
Parameter 22-80 Flow Compensation	+	+
Parameter 22-81 Square-linear Curve Approximation	+	+
Parameter 22-82 Work Point Calculation	+	+
Parameter 22-84 Speed at No-Flow [Hz]	+	+
Parameter 22-86 Speed at Design Point [Hz]	+	-
Parameter 22-87 Pressure at No-Flow Speed	+	+
Parameter 22-88 Pressure at Rated Speed	-	+
Parameter 22-89 Flow at Design Point	-	+
Parameter 22-90 Flow at Rated Speed	-	+

Table 3.12 Speed at Design Point Known/Unknown

22-80 Flow Compensation		
Option:	Function:	
[0] *	Disabled	Disable flow compensation of setpoint.
[1]	Enabled	Enable flow compensation of setpoint.

22-81 Square-linear Curve Approximation		
Range:	Function:	
100 %*	[ 0 - 100 % ]	Adjusts shape of control curve. 0% = straight line, 100% = maximum parabola.

22-82 Work Point Calculation		
Option:	Function:	
[0] *	Disabled	Disable calculation of working point at rated speed.
[1]	Enabled	Enable calculation of working point at rated speed.

22-84 Speed at No-Flow [Hz]		
Range:	Function:	
Size related*	[ 0 - 400.0 Hz ]	Set the motor speed in Hz at which flow is 0 and minimum pressure is achieved.

22-86 Speed at Design Point [Hz]		
Range:	Function:	
Size related*	[ 0.0 - 400.0 Hz ]	Set the motor speed in Hz at which system design working point is achieved.

22-87 Pressure at No-Flow Speed		
Range:	Function:	
0*	[ 0 - 4999.000 ]	Set the pressure value corresponding to speed at no flow.

22-88 Pressure at Rated Speed		
Range:	Function:	
4999.000*	[ 0 - 4999.000 ]	Set the pressure value corresponding to pressure at rated speed.

22-89 Flow at Design Point		
Range:	Function:	
0*	[ 0 - 4999.000 ]	Set the flow value corresponding to flow at design point.

### 3.16 Main Menu - Application Functions 2 - Group 24

#### 3.16.1 24-0\* Fire Mode

#### **CAUTION**

**EQUIPMENT DAMAGE AND PERSONAL INJURY**  
 Non-interruption of the frequency converter due to fire mode operation could cause overpressure and damage the system and its components, including dampers, and air ducts. The frequency converter itself could be damaged and it may cause damage or fire.

- Ensure that the system is properly designed and components used are carefully selected.
- Ensure that the ventilation systems working in life safety applications are approved by the local fire authorities.

#### Background

Fire mode is for use in critical situations, where it is imperative for the motor to keep running, regardless of the frequency converter's normal protective functions. These situations could be ventilation fans in tunnels or stairwells for instance, where continued operation of the fan facilitates safe evacuation of personnel in case of a fire. Some selections of fire mode function cause alarms and trip conditions to be ignored, enabling the motor to run without interruption.

**Activation**

Fire mode is activated only via digital input terminals. See *parameter group 5-1\* Digital Inputs*.

**Messages in display**

When fire mode is activated, the display shows the status message *Fire Mode*.

Once the fire mode is deactivated, the status message disappears.

If an alarm with warranty implications (see *parameter 24-09 FM Alarm Handling*) occurs while the frequency converter is active in fire mode, the display shows the status message *Fire Mode Limits Exceeded*. Once this status message appears in the display, it remains until a power cycle is performed. The frequency converter automatically logs and stores the condition in the memory and the warranty is still lost in case the frequency converter is returned for service.

Digital and relay outputs can be configured for the status messages *Fire Mode Active*. See *parameter group 5-3\* Digital Outputs* and *parameter group 5-4\* Relays*.

Access the status messages *Fire Mode* and *Fire Mode Limits Exceeded* via the extended status word.

Message	Type	Keyp ad	Message	Warning word 2	Extended status word 2
Fire Mode	Status	+	+		+ (bit 25)
Fire Mode Limits Exceeded	Status	+	+		+ (bit 27)

Table 3.13 Fire Mode Display Messages

**Log**

The fire mode log shows an overview of events related to fire mode in the fire mode log, see also *parameter group 18-1\* Fire Mode Log*.

The log includes up to 10 of the latest events. *Fire Mode Limits Exceeded* has a higher priority than *Fire Mode Active*. The log cannot be reset.

The following events are logged:

- Fire mode activated.
- Fire mode limits exceeded (warranty-affecting alarms).

All other alarms occurring while fire mode is active are logged as usual.

**NOTICE**

During fire mode operation, all stop commands to the frequency converter are ignored, including coast, coast inverse, and external interlock.

**NOTICE**

If setting the command [1] *Start Reversing* on a digital input terminal in *parameter 5-10 Terminal 18 Digital Input*, the drive understands this command as a reversing command.

24-00 FM Function		
Option:	Function:	
		<b>NOTICE</b> In fire mode, alarms are produced or ignored in accordance with the selection in <i>parameter 24-09 FM Alarm Handling</i> .
[0] *	Disabled	Fire mode function is not active.
[1]	Enabled-Run Forward	In this mode, the motor continues to operate in a clockwise direction.
[2]	Enabled-Run Reverse	In this mode, the motor continues to operate in a counterclockwise direction.
[3]	Enabled-Coast	While this mode is selected, the output is disabled, and the motor is allowed to coast to stop. When <i>parameter 24-01 Fire Mode Configuration</i> is set to [3] <i>Closed Loop</i> , this mode cannot be selected.
[4]	Enabled-Run Fwd/Rev	In this mode, the motor operates in a clockwise direction. When receiving a reversing signal, the motor operates in counterclockwise direction. If <i>parameter 24-01 Fire Mode Configuration</i> is set to [3] <i>Closed Loop</i> , the motor cannot operate in counterclockwise direction.

24-01 Fire Mode Configuration		
Select to use closed-loop or open-loop operations.		
Option:	Function:	
[0] *	Open Loop	
[3]	Process Closed Loop	<b>NOTICE</b> When set to [3] <i>Closed Loop</i> , the commands <i>Reversing</i> and <i>Start Reversing</i> do not reverse the direction of the motor.  Motor speed is determined by a reference from the built-in PI controller varying the motor speed as of a closed-loop control process (for example constant pressure or flow). Configure the PI controller in



24-01 Fire Mode Configuration		
Select to use closed-loop or open-loop operations.		
<b>Option:</b>		<b>Function:</b>
		<i>parameter group 20-8* PI Basic Setting and parameter group 20-9* PI Controller.</i>

24-05 FM Preset Reference		
<b>Range:</b>		<b>Function:</b>
0 %*	[-100 - 100 %]	Enter the required preset reference/ setpoint as a percentage of the fire mode maximum reference set in Hz.

24-06 Fire Mode Reference Source		
<b>Option:</b>		<b>Function:</b>
[0] *	No function	
[1]	Analog Input 53	
[2]	Analog Input 54	
[7]	Pulse input 29	

24-07 Fire Mode Feedback Source		
This parameter defines which input on the frequency converter should be treated as the source of the feedback signal.		
<b>Option:</b>		<b>Function:</b>
[0] *	No function	
[1]	Analog Input 53	
[2]	Analog Input 54	
[3]	Pulse input 29	
[100]	Bus Feedback 1	

24-09 Fire Mode Alarm Handling		
<b>Option:</b>		<b>Function:</b>
[0]	Trip+Reset, Critical Alarms	If this mode is selected, the frequency converter continues to run, ignoring most alarms, even if doing so may damage the frequency converter. Critical alarms are alarms that cannot be suppressed but a restart attempt is possible (infinity automatic reset).
[1]	Trip, Critical Alarms	In case of a critical alarm, the frequency converter trips and does not auto-restart (manual reset).
[2]	Trip, All Alarms/Test	It is possible to test the operation of fire mode, but all alarm states are activated normally (manual reset).

### NOTICE

Certain alarms can affect the lifetime of the frequency converter. If 1 of these ignored alarms occurs while in fire mode, a log of the event is stored in the fire mode log.

In fire mode log, the 10 latest events of alarms that affect warranty, fire mode activation, and fire mode deactivation are stored.

### NOTICE

The setting in *parameter 14-20 Reset Mode* is disregarded if fire mode is active (see *parameter group 24-0\* Fire Mode*).

Num ber	Description	Critical alarms	Warranty affecting alarms
4	Mains ph. Loss		x
7	DC over volt	x	x
9	Inverter overloaded		x
13	Overcurrent	x	x
14	Ground fault	x	x
16	Short circuit	x	x
38	Internal fault	x	
69	Power card temp		x

Table 3.14 Fire Mode Alarm Handling

### 3.16.2 24-1\* Drive Bypass

If a fire mode coast occurs (see *parameter 24-00 FM Function*), the frequency converter includes a feature that can automatically activate an external electro-mechanical bypass.

The bypass switches the motor to operation directly on line. One of the digital outputs or relays in the frequency converter activates the external bypass, when programmed in *parameter group 5-3\* Digital Outputs* or *parameter group 5-4\* Relays*.

### NOTICE

The drive bypass cannot be deactivated if in fire mode. It is deactivated only by either removing the fire mode command signal or the supply to the frequency converter.

When the drive bypass function is activated, the display on the keypad shows the status message *Drive Bypass*. This message has a higher priority than the fire mode status messages. When the automatic drive bypass function is enabled, it cuts in the external bypass according to *Illustration 3.18*.

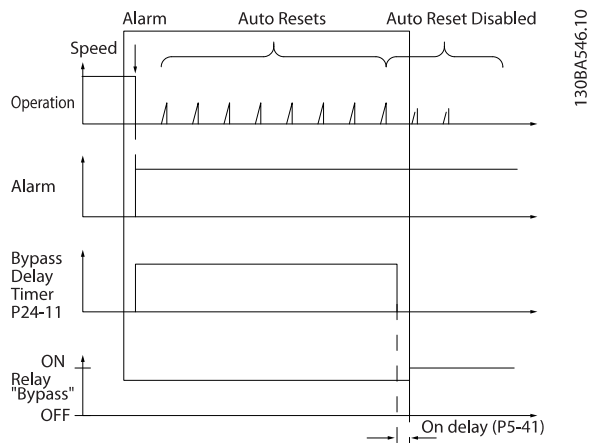

Illustration 3.18 Drive Bypass Function

24-10 Drive Bypass Function		
Option:		Function:
[0] *	Disabled	This parameter determines which circumstances activate the bypass function:
[2]	Enabled (Fire Mode only)	If the timer expires before reset attempts have completed, the bypass function operates a trip at critical alarms, coast, or bypass delay timer.

24-11 Drive Bypass Delay Time		
Range:		Function:
0 s*	[0 - 600 s]	Programmable in 1 s increments. Once the bypass function is activated in accordance with the setting in <i>parameter 24-10 Drive Bypass Function</i> , the bypass delay timer begins to operate. If the frequency converter has been set for several restart attempts, the timer continues to run while the frequency converter tries to restart. If the motor has restarted within the time period of the bypass delay timer, the timer is reset.  If the motor fails to restart at the end of the bypass delay time, the frequency converter bypass relay, which has been programmed for bypass in <i>parameter 5-40 Function Relay</i> , is activated.  Where no restart attempts are programmed, the timer runs for the delay period set in this parameter and then activates the frequency converter bypass relay, which has

24-11 Drive Bypass Delay Time		
Range:		Function:
		been programmed for bypass in <i>parameter 5-40 Function Relay</i> .

### 3.17 Main Menu - Special Features - Group 30

#### 3.17.1 30-2\* Adv. Start Adjust

Parameter group for advanced start adjustments.

30-22 Locked Rotor Protection		
Set the locked rotor detection for PM motors.		
Option:		Function:
[0] *	Off	
[1]	On	

30-23 Locked Rotor Detection Time [s]		
Range:		Function:
0.10 s	[0.05 - 1 s]	Set the locked rotor detection time in seconds for PM motors.

## 4 Troubleshooting

### 4.1 Introduction to Alarms and Warnings

A warning or alarm is signaled by the relevant indicator light on the front of the frequency converter and indicated by a code on the display.

A warning remains active until its cause is no longer present. Under certain circumstances, operation of the motor may still continue. Warning messages may be critical, but are not necessarily so.

If an alarm occurs, the frequency converter has tripped. Alarms must be reset to restart operation once their cause has been rectified.

**This may be done in 4 ways:**

1. By pressing [Reset].
2. Via a digital input with the *Reset* function.
3. Via serial communication.
4. By resetting automatically using the [Auto Reset] function, see *parameter 14-20 Reset Mode*.

**NOTICE**

After a manual reset pressing [Reset], press [Auto On] or [Hand On] to restart the motor.

If an alarm cannot be reset, the reason may be that its cause has not been rectified, or the alarm is trip-locked, see *Table 4.1*.

Alarms that are trip-locked offer additional protection, means that the mains supply must be switched off before the alarm can be reset. After being switched back on, the frequency converter is no longer blocked and may be reset as described above once the cause has been rectified. Alarms that are not trip-locked can also be reset using the automatic reset function in *parameter 14-20 Reset Mode*.

If a warning and alarm is marked against a code in the table on the following page, this means that either a warning occurs before an alarm, or it can be specified whether it is a warning or an alarm that is to be displayed for a given fault.

This is possible, for instance, in *parameter 1-90 Motor Thermal Protection*. After an alarm or trip, the motor carries on coasting, and the alarm flash on the frequency converter. Once the problem has been rectified, only the alarm continues flashing.

No.	Description	Warning	Alarm	Trip Lock	Parameter Reference
2	Live zero error	(X)	(X)	-	<i>Parameter 6-01 Live Zero Timeout Function</i>
3	No motor	(X)	-	-	<i>Parameter 1-80 Function at Stop</i>
4	Mains phase loss	(X)	(X)	(X)	<i>Parameter 14-12 Function at Mains Imbalance</i>
7	DC over voltage	X	X	-	-
8	DC under voltage	X	X	-	-
9	Inverter overloaded	X	X	-	-
10	Motor ETR overtemperature	(X)	(X)	-	<i>Parameter 1-90 Motor Thermal Protection</i>
11	Motor thermistor overtemperature	(X)	(X)	-	<i>Parameter 1-90 Motor Thermal Protection</i>
13	Overcurrent	X	X	X	-
14	Ground fault	X	X	X	-
16	Short circuit	-	X	X	-
17	Control word time-out	(X)	(X)	-	<i>Parameter 8-04 Control Timeout Function</i>
24	Fan fault (Only on 400 V 30-90kW)	X	X	-	<i>Parameter 14-53 Fan Monitor</i>
30	Motor phase U missing	-	(X)	(X)	<i>Parameter 4-58 Missing Motor Phase Function</i>
31	Motor phase V missing	-	(X)	(X)	<i>Parameter 4-58 Missing Motor Phase Function</i>

No.	Description	Warning	Alarm	Trip Lock	Parameter Reference
32	Motor phase W missing	–	(X)	(X)	<i>Parameter 4-58 Missing Motor Phase Function</i>
38	Internal fault	–	X	X	–
44	Ground fault 2	–	X	X	–
46	Gate drive voltage fault	–	X	X	–
47	24 V supply low	–	X	X	–
50	AMA calibration failed	–	X	–	–
51	AMA check U <sub>nom</sub> and I <sub>nom</sub>	–	X	–	–
52	AMA low I <sub>nom</sub>	–	X	–	–
53	AMA motor too large	–	X	–	–
54	AMA motor too small	–	X	–	–
55	AMA parameter out of range	–	X	–	–
56	AMA interrupted	–	X	–	–
57	AMA time-out	–	X	–	–
58	AMA internal fault	X	X	–	–
59	Current limit	X	–	–	–
60	External interlock	–	X	–	–
66	Heat sink temperature low	X	–	–	–
69	Power card temperature	X	X	X	–
79	Illegal PS config	X	X	–	–
80	Frequency converter initialised to default value	–	X	–	–
84	LCP error	X	–	–	–
87	Auto DC brake	X	–	–	–
92	No-Flow	(X)	(X)	–	<i>Parameter 22-23 No-Flow Function</i>
95	Broken belt	X	X	–	<i>Parameter group 22-6* Broken Belt Detection</i>
99	Locked rotor	–	X	X	–
126	Motor rotating	–	X	–	–
127	Back EMF too high	X	–	–	–
201	Fire mode	X	–	–	–
202	Fire mode limits exceeded	X	–	–	–
250	New spare parts	–	X	X	–
251	New type code	–	X	X	–

**Table 4.1 Alarm/Warning Code List**

(X) *Dependent on parameter*

A trip is the action when an alarm has appeared. The trip coasts the motor and can be reset by pressing [Reset] or via a digital input (*parameter group 5-1\* Digital Inputs [1]*). The original event that caused an alarm cannot damage the frequency converter or cause dangerous conditions. A trip lock is an action when an alarm occurs, which may cause damage to the frequency converter or connected parts. A trip lock situation can only be reset by a power cycling.

Warning	yellow
Alarm	flashing red

**Table 4.2 LED Indication**

The alarm words, warning words, and extended status words can be read out via fieldbus or optional fieldbus for diagnosis. See also *parameter 16-90 Alarm Word*, *parameter 16-92 Warning Word*, and *parameter 16-94 Ext. Status Word*.

### 4.2 Alarm Words

Bit	Hex	Dec	Parameter 16-9 0 Alarm Word	Parameter 16-9 1 Alarm Word 2
0	1	1	0	0
1	2	2	Pwr.Card Temp	0
2	4	4	Earth Fault	ServiceTrip, Typecode
3	8	8	0	Sparepart
4	10	16	Ctrl. Word TO	0
5	20	32	Over Current	No Flow
6	40	64	0	0
7	80	128	Motor Th. Over	0
8	100	256	Motor ETR Over	Broken Belt
9	200	512	Inverter Overld.	0
10	400	1024	DC under Volt	0
11	800	2048	DC over Volt.	0
12	1000	4096	Short Circuit	External Interlock
13	2000	8192	0	0
14	4000	16384	Mains ph. loss	0
15	8000	32768	AMA Not OK	0
16	10000	65536	Live Zero Error	0
17	20000	131072	Internal Fault	0
18	40000	262144	0	Fans error
19	80000	524288	U phase Loss	0
20	100000	1048576	V phase Loss	0
21	200000	2097152	W phase Loss	0
22	400000	4194304	0	0
23	800000	8388608	Control Voltage Fault	0
24	1000000	16777216	0	0
25	2000000	33554432	VDD1 Supply Low	0
26	4000000	67108864	0	0
27	8000000	134217728	0	0
28	10000000	268435456	Earth fault	0
29	20000000	536870912	Drive Initialized	0
30	40000000	1073741824	0	0
31	80000000	2147483648	0	0

Table 4.3 Alarm Words

### 4.3 Warning Words

Bit	Hex	Dec	Parameter 16-9 2 Warning Word	Parameter 16-9 3 Warning Word 2
0	1	1	0	0
1	2	2	Pwr.Card Temp	0
2	4	4	Earth Fault	0
3	8	8	0	0
4	10	16	Ctrl. Word TO	0
5	20	32	Over Current	No-Flow
6	40	64	0	0
7	80	128	Motor Th. Over	0
8	100	256	Motor ETR Over	Broken Belt
9	200	512	Inverter Overld.	0
10	400	1024	DC under Volt	0
11	800	2048	DC over Volt.	0
12	1000	4096	0	0
13	2000	8192	0	0
14	4000	16384	Mains ph. loss	0
15	8000	32768	No Motor	Auto DC Braking
16	10000	65536	Live Zero Error	0
17	20000	131072	0	0
18	40000	262144	0	Fans Warning
19	80000	524288	0	0
20	100000	1048576	0	0
21	200000	2097152	0	0
22	400000	4194304	0	Memory Module
23	800000	8388608	24 V Supply Low	0
24	1000000	16777216	0	0
25	2000000	33554432	Current Limit	0
26	4000000	67108864	Low temp.	0
27	8000000	134217728	0	0
28	10000000	268435456	0	0
29	20000000	536870912	0	Back-EMF too High
30	40000000	1073741824	0	0
31	80000000	2147483648	0	0

Table 4.4 Warning Words

Note that 0 in Table 4.4 indicates that this status word is not supported.

#### 4.4 Extended Status Words

Bit	Hex	Dec	Parameter 16 -94 Ext. Status Word	Parameter 16-95 Ext. Status Word 2
0	1	1	Ramping	Off
1	2	2	AMA running	Hand/Auto
2	4	4	Start CW/CCW	0
3	8	8	0	0
4	10	16	0	0
5	20	32	Feedback high	0
6	40	64	Feedback low	0
7	80	128	Output current high	Control Ready
8	100	256	Output current low	Drive Ready
9	200	512	Output frequency high	Quick Stop
10	400	1024	Output frequency low	DC Brake
11	800	2048	0	Stop
12	1000	4096	0	0
13	2000	8192	Braking	Freeze Output Request
14	4000	16384	0	Freeze Output
15	8000	32768	OVC active	Jog Request
16	10000	65536	AC brake	Jog
17	20000	131072	0	Start request
18	40000	262144	0	Start
19	80000	524288	Reference high	0
20	100000	1048576	Reference low	Start Delay
21	200000	2097152	0	Sleep
22	400000	4194304	0	Sleep boost
23	800000	8388608	0	Running
24	1000000	16777216	0	Bypass
25	2000000	33554432	0	Fire Mode
26	4000000	67108864	0	External Interlock
27	8000000	134217728	0	Firemodelimi- texceed
28	10000000	268435456	0	FlyStart Active
29	20000000	536870912	0	0
30	40000000	1073741824	0	0
31	80000000	2147483648	Database busy	0

Table 4.5 Extended Status Words

#### 4.5 List of Warnings and Alarms

### **WARNING**

#### Hazardous Service Procedures!

The maintenance and troubleshooting procedures recommended in this section of the manual could result in exposure to electrical, mechanical, or other potential safety hazards. Always refer to the safety warnings provided throughout this manual concerning these procedures. Unless specified otherwise, disconnect all electrical power including remote disconnect and discharge all energy storing devices such as capacitors before servicing. Follow proper lockout/tagout procedures to ensure the power cannot be inadvertently energised. When it is necessary to work with live electrical components, have a qualified licensed electrician or other individual who has been trained in handling live electrical components perform these tasks. Failure to follow all of the recommended safety warnings provided, could result in death or serious injury.

#### WARNING/ALARM 2, Live zero error

This warning or alarm only appears if *parameter 6-01 Live Zero Timeout Function* is configured. The signal on 1 of the analog inputs is less than 50% of the minimum value programmed for that input. This condition can be caused by broken wiring or a faulty device sending the signal.

#### WARNING/ALARM 3, No motor

No motor is connected to the output of the frequency converter. Check the cable connection between the frequency converter and the motor.

#### WARNING/ALARM 4, Mains phase loss

A phase is missing on the supply side, or the mains voltage imbalance is too high. This message also appears for a fault in the input rectifier on the frequency converter. Options are programmed at *parameter 14-12 Function at Mains Imbalance*.

### **CAUTION**

#### Live Electrical Components!

#### Troubleshooting

- Check the supply voltage and supply currents to the frequency converter.

#### WARNING/ALARM 7, DC overvoltage

If the DC-link voltage exceeds the limit, the frequency converter trips after a time.

#### Troubleshooting

- Extend the ramp time.
- Activate functions in *parameter 2-10 Brake Function*.
- Activate overvoltage control in *parameter 2-17 Over-voltage Control*.

**WARNING/ALARM 8, DC under voltage**

If the DC-link voltage (DC) drops below the undervoltage limit, the frequency converter trips after a fixed time delay. The time delay varies with unit size.

**WARNING/ALARM 9, Inverter overloaded**

The frequency converter is about to cut out because of an overload (too high current for too long). The counter for electronic, thermal inverter protection issues a warning at 90% and trips at 100%, while issuing an alarm. The frequency converter cannot be reset until the counter is below 90%.

The fault is that the frequency converter is overloaded by more than 100% for too long.

**NOTICE**

See the *chapter Derating* in the *design guide* for more details, if a high switching frequency is required.

**WARNING/ALARM 10, Motor overload temperature**

According to the electronic thermal protection (ETR), the motor is too hot. Select whether the frequency converter issues a warning or an alarm when the counter reaches 100% in *parameter 1-90 Motor Thermal Protection*. The fault is that the motor is overloaded by more than 100% for too long.

**CAUTION**

Live Electrical Components!

**Troubleshooting**

- Check if the motor is overheating.
- Check if the motor is mechanically overloaded.
- Ensure that the motor *parameter 1-24 Motor Current* is set correctly.
- Ensure motor data in parameters 1-20 through 1-25 are set correctly.
- Run *AMA* in *parameter 1-29 Automatic Motor Adaption (AMA)*.

**WARNING/ALARM 11, Motor thermistor over temp**
**CAUTION**

Disconnect power before proceeding.

**WARNING/ALARM 13, Overcurrent**

The inverter peak current limit is exceeded. The warning lasts about 1.5 s, then the frequency converter trips and issues an alarm.

**Troubleshooting**

- This fault may be caused by shock loading or fast acceleration with high inertia loads.
- Turn off the frequency converter. Check if the motor shaft can be turned.
- Check that the motor size matches the frequency converter.

- Incorrect motor data in parameters 1-20 to 1-25.

**ALARM 14, Earth (ground) fault**

There is a discharge from the output phases to ground, either in the cable between the frequency converter and the motor or in the motor itself.

**CAUTION**

Disconnect power before proceeding.

**Troubleshooting**

- Turn off the frequency converter and remove the ground fault.
- Measure the resistance to ground the motor cables and the motor with a megohmmeter to check for ground faults in the motor.

**ALARM 16, Short circuit**

There is short-circuiting in the motor or on the motor terminals.

**CAUTION**

Disconnect power before proceeding.

Turn off the frequency converter and remove the short circuit.

**WARNING/ALARM 17, Control word timeout**

There is no communication to the frequency converter. The warning is only active when *parameter 8-04 Control Timeout Function* is not set to [0] Off.

If *parameter 8-04 Control Timeout Function* is set to [5] Stop and trip, a warning appears and the frequency converter ramps down until it trips while giving an alarm.

**WARNING**

Live Electrical Components!

**Troubleshooting**

- Check connections on the serial communication cable.
- Increase *parameter 8-03 Control Timeout Time*.
- Check operation of the communication equipment.
- Verify proper installation based on EMC requirements.

**WARNING/ALARM 24, Fan fault**

The fan warning function is an extra protection function that checks whether the fan is running/mounted. The fan warning can be disabled in *parameter 14-53 Fan Monitor ([0] Disabled)*.

**Troubleshooting**

- Check fan resistance.

**ALARM 30, Motor phase U missing**

Motor phase U between the frequency converter and the motor is missing.



**Disconnect power before proceeding.**

Turn off the frequency converter and check motor phase U.

**ALARM 31, Motor phase V missing**

Motor phase V between the frequency converter and the motor is missing.



**Disconnect power before proceeding.**

Turn off the frequency converter and check motor phase V.

**ALARM 32, Motor phase W missing**

Motor phase W between the frequency converter and the motor is missing.



**Disconnect power before proceeding.**

Turn off the frequency converter and check motor phase W.

**ALARM 38, Internal fault**

Contact your Trane supplier.

**ALARM 44, Earth fault II**

There is a discharge from the output phases to ground, either in the cable between the frequency converter and the motor or in the motor itself.

**Troubleshooting**

- Turn off the frequency converter and remove the ground fault.
- Measure the resistance to ground of the motor cables and the motor with a megohmmeter to check for a ground fault in the motor.

**ALARM 46, Gate drive voltage low**

The supply on the power card is out of range. There are 3 supplies generated by the switch mode power supply (SMPS) on the power card: 24 V, 5 V, and  $\pm 18$  V.

**Troubleshooting**

- Check the power card.

**ALARM 47, 24 V supply low**

The 24 Vdc is measured on the control card.

**ALARM 51, AMA check Unom and Inom**

The setting of motor voltage, motor current, and motor power is presumably wrong. Check the settings.

**ALARM 52, AMA low Inom**

The motor current is too low. Check the settings.

**ALARM 53, AMA motor too big**

The motor is too large for the AMA to be performed.

**ALARM 54, AMA motor too small**

The motor is too small for the AMA to be performed.

**ALARM 55, AMA Parameter out of range**

The parameter values found from the motor are outside the acceptable range.

**ALARM 56, AMA interrupted by user**

The AMA is interrupted.

**ALARM 57, AMA timeout**

Try to start the AMA again a number of times, until the AMA is performed. Note that repeated runs may heat the motor to a level where the resistance  $R_s$  and  $R_r$  are increased. In most cases, this is not critical.

**ALARM 58, AMA internal fault**

Contact your Trane supplier.

**WARNING 59, Current limit**

The current is higher than the value in *parameter 4-18 Current Limit*.

**ALARM 60, External interlock**

External interlock has been activated. To resume normal operation, apply 24 Vdc to the terminal programmed for external interlock and reset the frequency converter (via serial communication, digital I/O, or by pressing [Reset]).

**ALARM 69, Power card temperature**

The temperature on the power card is either too high or too low.

**Troubleshooting**

- Ensure that the ambient operating temperature is within the limits.
- Check if the filters are clogged.
- Check the fan operation.
- Check the power card.

**ALARM 70, Illegal power section configuration**

The control card and power card are incompatible. Contact the local supplier with the type code of the unit from the nameplate and the part numbers of the cards to check compatibility.

**ALARM 80, Drive initialised to default value**

Parameter settings are initialized to default settings after a manual reset.

**WARNING/ALARM 92, No flow**

A no-flow condition has been detected in the system. *Parameter 22-23 No-Flow Function* is set for alarm.

Troubleshoot the system and reset the frequency converter after the fault has been cleared.

**WARNING/ALARM 95, Broken belt**

Torque is below the torque level set for no load, indicating a broken belt. See *parameter group 22-6\* Broken Belt Detection*.



**ALARM 99, Locked rotor**

Rotor is blocked.

**ALARM 101, Flow/pressure info missing**

Sensorless-pump table is missing or wrong.

**Troubleshooting**

- Download sensorless-pump table again.

**ALARM 126, Motor Rotating**

High back EMF voltage. Stop the rotor of the PM motor.

**WARNING 127, Back EMF too high**

This warning only applies to PM motors. When the back EMF is larger than  $90\% \cdot U_{invmax}$  (overvoltage threshold), and does not fall to a normal level within 5 s, this warning occurs.

**WARNING 200, Fire Mode**

Fire mode has been activated.

**WARNING 202, Fire Mode Limits Exceeded**

Fire mode has suppressed 1 or more warranty-voiding alarms.

**ALARM 250, New Spare Part**

The power or switch mode supply has been exchanged.

**ALARM 251, New Type Code**

The frequency converter has a new type code.

**4.6 List of Keypad Errors**

Keypad errors are not warnings or alarms. They do not affect the operation of the frequency converter. *Illustration 4.1* shows an keypad error on the keypad.

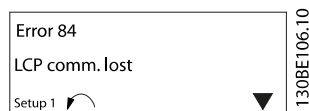

**Illustration 4.1 keypad Error Example**

LCP error code	Error message	Description
Err 84	LCP comm. Lost	Communication between the keypad and the frequency converter is lost.
Err 85	Key disabled	The keypad key is disabled. One of the keypad keys has been disabled in <i>parameter group 0-4* LCP Keypad</i> .
Err 86	LCP copy failed	Data copy failure. This error occurs when data is copied from frequency converter to keypad, or from keypad to frequency converter ( <i>parameter 0-50 LCP Copy</i> ).
Err 88	Data not compatible	Keypad data incompatible. This error occurs when data is being copied from keypad to frequency converter ( <i>parameter 0-50 LCP Copy</i> ). The typical reason is that data is moved between frequency converter and keypad that have major software differences.
Err 89	Read only	Parameter read only. An operation is issued via keypad to write a value to a parameter that is read-only.
Err 90	Database busy	The parameter database of the frequency converter is busy.
Err 91	Parameter invalid	The parameter value that is input via the keypad is invalid.
Err 92	Exceeds limits	The parameter value that is input via the keypad exceeds limits.
Err 93	Motor is running	The keypad copy operation cannot be performed when the frequency converter is running.
Err 95	Not while running	The parameter cannot be changed while the frequency converter is running.
Err 96	Password rejected	The password that is input via the keypad is incorrect.

**Table 4.6 Keypad Error List**

## 5 Parameter Lists

### 5.1 Parameter Options

#### 5.1.1 Default Settings

##### Changes during operation

True: The parameter can be changed while the frequency converter is in operation.

False: The parameter can only be changed when the frequency converter stops.

##### 2-Set-up

All set-ups: The parameter can be set individually in each of the 2 set-ups. 1 single parameter can have 2 different data values.

1 set-up: Data value is the same in all set-ups.

##### ExpressionLimit

Size-related

##### N/A

No default value available.

##### Conversion index

This number refers to a conversion figure used when writing or reading via a frequency converter.

Conv. index	100	75	74	70	67	6	5	4	3	2	1	0	-1	-2	-3	-4	-5	-6
Conv. factor	1	3600000	3600	60	1/60	1000000	100000	10000	1000	100	10	1	0.1	0.01	0.001	0.0001	0.00001	0.000001

Data type	Description	Type
2	Integer 8	Int8
3	Integer 16	Int16
4	Integer 32	Int32
5	Unsigned 8	UInt8
6	Unsigned 16	UInt16
7	Unsigned 32	UInt32
9	Visible string	VisStr
33	Normalized value 2 bytes	N2
35	Bit sequence of 16 boolean variables	V2

Table 5.1 Data Type

## 5.1.2 0-\*\* Operation/Display

Par. No. #	Parameter description	Default value	2-set-up	Change during operation	Conversion index	Type
<b>0-0* Basic Settings</b>						
0-01	Language	[0] English	1 set-up	TRUE	-	UInt8
0-03	Regional Settings	[0] International	1 set-up	FALSE	-	UInt8
0-04	Operating State at Power-up	[0] Resume	All set-ups	FALSE	-	UInt8
0-06	GridType	ExpressionLimit	1 set-up	FALSE	-	UInt8
0-07	Auto DC Braking	[1] On	1 set-up	FALSE	-	UInt8
<b>0-1* Set-up Operations</b>						
0-10	Active Set-up	[1] Set-up 1	1 set-up	FALSE	-	UInt8
0-11	Programming Set-up	[9] Active Set-up	1 set-up	FALSE	-	UInt8
0-12	Link Setups	[20] Linked	All set-ups	FALSE	-	UInt8
<b>0-3* LCP Custom Readout</b>						
0-30	Custom Readout Unit	[1] %	1 set-up	FALSE	-	UInt8
0-31	Custom Readout Min Value	0 CustomReadoutUnit	1 set-up	TRUE	-2	Int32
0-32	Custom Readout Max Value	100 CustomReadoutUnit	1 set-up	TRUE	-2	Int32
0-37	Display Text 1	0 N/A	1 set-up	FALSE	0	VisStr[21]
0-38	Display Text 2	0 N/A	1 set-up	FALSE	0	VisStr[26]
0-39	Display Text 3	0 N/A	1 set-up	FALSE	0	VisStr[26]
<b>0-4* LCP Keypad</b>						
0-40	[Hand on] Key on LCP	[1] Enabled	All set-ups	FALSE	-	UInt8
0-42	[Auto on] Key on LCP	[1] Enabled	All set-ups	FALSE	-	UInt8
0-44	[Off/Reset] Key on LCP	[1] Enabled	All set-ups	FALSE	-	UInt8
<b>0-5* Copy/Save</b>						
0-50	LCP Copy	[0] No copy	1 set-up	FALSE	-	UInt8
0-51	Set-up Copy	[0] No copy	1 set-up	FALSE	-	UInt8
<b>0-6* Password</b>						
0-60	Main Menu Password	0 N/A	1 set-up	FALSE	0	UInt16
0-61	Access to Main Menu w/o Password	[0] Full access	1 set-up	FALSE	-	UInt8

## 5.1.3 1-\*\* Load and Motor

Par. No. #	Parameter description	Default value	2-set-up	Change during operation	Conversion index	Type
<b>1-0* General Settings</b>						
1-00	Configuration Mode	[0] Open Loop	All set-ups	FALSE	-	UInt8
1-01	Motor Control Principle	[1] VVC+	All set-ups	FALSE	-	UInt8
1-03	Torque Characteristics	[1] Variable Torque	All set-ups	FALSE	-	UInt8
1-06	Clockwise Direction	[0] Normal	1 set-up	FALSE	-	UInt8
1-08	Motor Control Bandwidth	ExpressionLimit	All set-ups	FALSE	-	UInt8
<b>1-1* Motor Selection</b>						
1-10	Motor Construction	[0] Asynchron	All set-ups	FALSE	-	UInt8
1-11	Motor Selection	[0] Default Motor Selection	All set-ups	FALSE	-	UInt8
1-14	Damping Gain	120%	All set-ups	FALSE	0	Int16
1-15	Low Speed Filter Time Const.	ExpressionLimit	All set-ups	FALSE	-2	UInt16
1-16	High Speed Filter Time Const.	ExpressionLimit	All set-ups	FALSE	-2	UInt16
1-17	Voltage filter time const.	ExpressionLimit	All set-ups	FALSE	-3	UInt16
<b>1-2* Motor Data</b>						
1-20	Motor Power	ExpressionLimit	All set-ups	FALSE	-	UInt8
1-22	Motor Voltage	ExpressionLimit	All set-ups	FALSE	0	UInt16
1-23	Motor Frequency	ExpressionLimit	All set-ups	FALSE	0	UInt16
1-24	Motor Current	ExpressionLimit	All set-ups	FALSE	-2	UInt32

Par. No. #	Parameter description	Default value	2-set-up	Change during operation	Conversion index	Type
1-25	Motor Nominal Speed	ExpressionLimit	All set-ups	FALSE	67	Uint16
1-26	Motor Cont. Rated Torque	ExpressionLimit	All set-ups	FALSE	-1	Uint32
1-29	Automatic Motor Adaption (AMA)	[0] Off	All set-ups	FALSE	-	Uint8
<b>1-3* Adv. Motor Data</b>						
1-30	Stator Resistance (Rs)	ExpressionLimit	All set-ups	FALSE	-3	Uint32
1-33	Stator Leakage Reactance (X1)	ExpressionLimit	All set-ups	FALSE	-3	Uint32
1-35	Main Reactance (Xh)	ExpressionLimit	All set-ups	FALSE	-2	Uint32
1-37	d-axis Inductance (Ld)	ExpressionLimit	All set-ups	FALSE	-6	Int32
1-38	q-axis Inductance (Lq)	ExpressionLimit	All set-ups	FALSE	-6	Int32
1-39	Motor Poles	ExpressionLimit	All set-ups	FALSE	0	Uint8
<b>1-4* Adv. Motor Data II</b>						
1-40	Back EMF at 1000 RPM	ExpressionLimit	All set-ups	FALSE	0	Uint16
1-44	d-axis Inductance Sat. (LdSat)	ExpressionLimit	All set-ups	FALSE	-6	Int32
1-45	q-axis Inductance Sat. (LqSat)	ExpressionLimit	All set-ups	FALSE	-6	Int32
1-46	Position Detection Gain	100%	All set-ups	FALSE	0	Uint16
1-48	Current at Min Inductance for d-axis	100%	All set-ups	FALSE	0	Int16
1-49	Current at Min Inductance for q-axis	100%	All set-ups	FALSE	0	Uint16
<b>1-5* Load Indep. Setting</b>						
1-50	Motor Magnetisation at Zero Speed	100%	All set-ups	FALSE	0	Uint16
1-52	Min Speed Normal Magnetising [Hz]	1 Hz	All set-ups	FALSE	-1	Uint16
1-55	U/f Characteristic - U	ExpressionLimit	All set-ups	FALSE	-1	Uint16
1-56	U/f Characteristic - F	ExpressionLimit	All set-ups	FALSE	-1	Uint16
<b>1-6* Load Depen. Setting</b>						
1-62	Slip Compensation	ExpressionLimit	All set-ups	FALSE	0	Int16
1-63	Slip Compensation Time Constant	0.1 s	All set-ups	FALSE	-2	Uint16
1-64	Resonance Dampening	100%	All set-ups	FALSE	0	Uint16
1-65	Resonance Dampening Time Constant	0.005 s	All set-ups	FALSE	-3	Uint16
1-66	Min. Current at Low Speed	50%	All set-ups	FALSE	0	Uint32
<b>1-7* Start Adjustments</b>						
1-70	PM Start Mode	[1] Parking	All set-ups	FALSE	-	Uint8
1-71	Start Delay	0 s	All set-ups	FALSE	-1	Uint8
1-72	Start Function	[2] Coast/delay time	All set-ups	FALSE	-	Uint8
1-73	Flying Start	[0] Disabled	All set-ups	FALSE	-	Uint8
<b>1-8* Stop Adjustments</b>						
1-80	Function at Stop	[0] Coast	All set-ups	FALSE	-	Uint8
1-82	Min Speed for Function at Stop [Hz]	0 Hz	All set-ups	FALSE	-1	Uint16
1-88	AC Brake Gain	1.4 N/A	All set-ups	FALSE	-1	Uint16
<b>1-9* Motor Temperature</b>						
1-90	Motor Thermal Protection	[4] ETR trip 1	All set-ups	FALSE	-	Uint8
1-93	Thermistor Source	[0] None	All set-ups	FALSE	-	Uint8

## 5.1.4 2-\*\* Brakes

Par. No. #	Parameter description	Default value	2-set-up	Change during operation	Conversion index	Type
<b>2-0* DC-Brake</b>						
2-00	DC Hold/Motor Preheat Current	50%	All set-ups	FALSE	0	Uint16
2-01	DC Brake Current	50%	All set-ups	FALSE	0	Uint16
2-02	DC Braking Time	10 s	All set-ups	FALSE	-1	Uint16
2-04	DC Brake Cut In Speed	0 Hz	All set-ups	FALSE	-1	Uint16
2-06	Parking Current	100%	All set-ups	FALSE	0	Uint16
2-07	Parking Time	3 s	All set-ups	FALSE	-1	Uint16
<b>2-1* Brake Energy Funct.</b>						
2-10	Brake Function	[0] Off	All set-ups	FALSE	-	Uint8
2-16	AC Brake, Max current	100%	All set-ups	FALSE	-1	Uint16
2-17	Over-voltage Control	[2] Enabled	All set-ups	FALSE	-	Uint8

## 5.1.5 3-\*\* Reference/Ramps

Par. No. #	Parameter description	Default value	2-set-up	Change during operation	Conversion index	Type
<b>3-0* Reference Limits</b>						
3-02	Minimum Reference	0 ReferenceFeedbackUnit	All set-ups	FALSE	-3	Int32
3-03	Maximum Reference	ExpressionLimit	All set-ups	FALSE	-3	Int32
<b>3-1* References</b>						
3-10	Preset Reference	0%	All set-ups	TRUE	-2	Int16
3-11	Jog Speed [Hz]	5 Hz	All set-ups	TRUE	-1	Uint16
3-14	Preset Relative Reference	0%	All set-ups	TRUE	-2	Int16
3-15	Reference 1 Source	[1] Analog Input 53	All set-ups	FALSE	-	Uint8
3-16	Reference 2 Source	[2] Analog Input 54	All set-ups	FALSE	-	Uint8
3-17	Reference 3 Source	[11] Local bus reference	All set-ups	FALSE	-	Uint8
<b>3-4* Ramp 1</b>						
3-41	Ramp 1 Ramp Up Time	ExpressionLimit	All set-ups	FALSE	-2	Uint32
3-42	Ramp 1 Ramp Down Time	ExpressionLimit	All set-ups	FALSE	-2	Uint32
<b>3-5* Ramp 2</b>						
3-51	Ramp 2 Ramp Up Time	ExpressionLimit	All set-ups	FALSE	-2	Uint32
3-52	Ramp 2 Ramp Down Time	ExpressionLimit	All set-ups	FALSE	-2	Uint32
<b>3-8* Other Ramps</b>						
3-80	Jog Ramp Time	ExpressionLimit	All set-ups	FALSE	-2	Uint32
3-81	Quick Stop Ramp Time	ExpressionLimit	1 set-up	FALSE	-2	Uint32

5.1.6 4-\*\* Limits/Warnings

Par. No. #	Parameter description	Default value	2-set-up	Change during operation	Conversion index	Type
<b>4-1* Motor Limits</b>						
4-10	Motor Speed Direction	[2] Both directions	All set-ups	FALSE	-	Uint8
4-12	Motor Speed Low Limit [Hz]	0 Hz	All set-ups	FALSE	-1	Uint16
4-14	Motor Speed High Limit [Hz]	ExpressionLimit	All set-ups	FALSE	-1	Uint16
4-18	Current Limit	ExpressionLimit	All set-ups	FALSE	0	Uint16
4-19	Max Output Frequency	ExpressionLimit	All set-ups	FALSE	-1	Uint16
<b>4-4* Adj. Warnings 2</b>						
4-40	Warning Freq. Low	ExpressionLimit	All set-ups	FALSE	-1	Uint16
4-41	Warning Freq. High	ExpressionLimit	All set-ups	FALSE	-1	Uint16
<b>4-5* Adj. Warnings</b>						
4-50	Warning Current Low	0 A	All set-ups	FALSE	-2	Uint32
4-51	Warning Current High	ExpressionLimit	All set-ups	FALSE	-2	Uint32
4-54	Warning Reference Low	-4999 N/A	All set-ups	FALSE	-3	Int32
4-55	Warning Reference High	4999 N/A	All set-ups	FALSE	-3	Int32
4-56	Warning Feedback Low	-4999 ProcessCtrlUnit	All set-ups	FALSE	-3	Int32
4-57	Warning Feedback High	4999 ProcessCtrlUnit	All set-ups	FALSE	-3	Int32
4-58	Missing Motor Phase Function	[1] On	All set-ups	FALSE	-	Uint8
<b>4-6* Speed Bypass</b>						
4-61	Bypass Speed From [Hz]	0 Hz	All set-ups	FALSE	-1	Uint16
4-63	Bypass Speed To [Hz]	0 Hz	All set-ups	FALSE	-1	Uint16
4-64	Semi-Auto Bypass Set-up	[0] Off	All set-ups	FALSE	-	Uint8

5.1.7 5-\*\* Digital In/Out

Par. No. #	Parameter description	Default value	2-set-up	Change during operation	Conversion index	Type
<b>5-0* Digital I/O mode</b>						
5-00	Digital Input Mode	[0] PNP	1 set-up	FALSE	-	Uint8
5-03	Digital Input 29 Mode	[0] PNP	All set-ups	FALSE	-	Uint8
<b>5-1* Digital Inputs</b>						
5-10	Terminal 18 Digital Input	[8] Start	All set-ups	FALSE	-	Uint8
5-11	Terminal 19 Digital Input	[0] No operation	All set-ups	FALSE	-	Uint8
5-12	Terminal 27 Digital Input	ExpressionLimit	All set-ups	FALSE	-	Uint8
5-13	Terminal 29 Digital Input	[14] Jog	All set-ups	FALSE	-	Uint8
<b>5-3* Digital Outputs</b>						
5-34	On Delay, Digital Output	0.01 s	All set-ups	FALSE	-2	Uint16
5-35	Off Delay, Digital Output	0.01 s	All set-ups	FALSE	-2	Uint16
<b>5-4* Relays</b>						
5-40	Function Relay	ExpressionLimit	All set-ups	FALSE	-	Uint8
5-41	On Delay, Relay	0.01 s	All set-ups	FALSE	-2	Uint16
5-42	Off Delay, Relay	0.01 s	All set-ups	FALSE	-2	Uint16
<b>5-5* Pulse Input</b>						
5-50	Term. 29 Low Frequency	20 Hz	All set-ups	FALSE	0	Uint32
5-51	Term. 29 High Frequency	32000 Hz	All set-ups	FALSE	0	Uint32
5-52	Term. 29 Low Ref./Feedb. Value	0 N/A	All set-ups	FALSE	-3	Int32
5-53	Term. 29 High Ref./Feedb. Value	ExpressionLimit	All set-ups	FALSE	-3	Int32
<b>5-9* Bus Controlled</b>						
5-90	Digital & Relay Bus Control	0 N/A	All set-ups	FALSE	0	Uint32

## 5.1.8 6-\*\* Analog In/Out

Par. No. #	Parameter description	Default value	2-set-up	Change during operation	Conversion index	Type
<b>6-0* Analog I/O Mode</b>						
6-00	Live Zero Timeout Time	10 s	All set-ups	FALSE	0	Uint8
6-01	Live Zero Timeout Function	[0] Off	All set-ups	FALSE	-	Uint8
6-02	Fire Mode Live Zero Timeout Function	[0] Off	All set-ups	FALSE	-	Uint8
<b>6-1* Analog Input 53</b>						
6-10	Terminal 53 Low Voltage	0.07 V	All set-ups	FALSE	-2	Uint16
6-11	Terminal 53 High Voltage	10 V	All set-ups	FALSE	-2	Uint16
6-12	Terminal 53 Low Current	4 mA	All set-ups	FALSE	-5	Uint16
6-13	Terminal 53 High Current	20 mA	All set-ups	FALSE	-5	Uint16
6-14	Terminal 53 Low Ref./Feedb. Value	0 N/A	All set-ups	FALSE	-3	Int32
6-15	Terminal 53 High Ref./Feedb. Value	ExpressionLimit	All set-ups	FALSE	-3	Int32
6-16	Terminal 53 Filter Time Constant	0.01 s	All set-ups	FALSE	-2	Uint16
6-19	Terminal 53 mode	[1] Voltage mode	1 set-up	FALSE	-	Uint8
<b>6-2* Analog Input 54</b>						
6-20	Terminal 54 Low Voltage	0.07 V	All set-ups	FALSE	-2	Uint16
6-21	Terminal 54 High Voltage	10 V	All set-ups	FALSE	-2	Uint16
6-22	Terminal 54 Low Current	4 mA	All set-ups	FALSE	-5	Uint16
6-23	Terminal 54 High Current	20 mA	All set-ups	FALSE	-5	Uint16
6-24	Terminal 54 Low Ref./Feedb. Value	0 N/A	All set-ups	FALSE	-3	Int32
6-25	Terminal 54 High Ref./Feedb. Value	ExpressionLimit	All set-ups	FALSE	-3	Int32
6-26	Terminal 54 Filter Time Constant	0.01 s	All set-ups	FALSE	-2	Uint16
6-29	Terminal 54 mode	[1] Voltage mode	1 set-up	FALSE	-	Uint8
<b>6-7* Analog/Digital Output 45</b>						
6-70	Terminal 45 Mode	[0] 0-20 mA	All set-ups	FALSE	-	Uint8
6-71	Terminal 45 Analog Output	[0] No operation	All set-ups	FALSE	-	Uint8
6-72	Terminal 45 Digital Output	[0] No operation	All set-ups	FALSE	-	Uint8
6-73	Terminal 45 Output Min Scale	0%	All set-ups	FALSE	-2	Uint16
6-74	Terminal 45 Output Max Scale	100%	All set-ups	FALSE	-2	Uint16
6-76	Terminal 45 Output Bus Control	0 N/A	All set-ups	FALSE	0	Uint16
<b>6-9* Analog/Digital Output 42</b>						
6-90	Terminal 42 Mode	[0] 0-20 mA	All set-ups	FALSE	-	Uint8
6-91	Terminal 42 Analog Output	[0] No operation	All set-ups	FALSE	-	Uint8
6-92	Terminal 42 Digital Output	[0] No operation	All set-ups	FALSE	-	Uint8
6-93	Terminal 42 Output Min Scale	0%	All set-ups	FALSE	-2	Uint16
6-94	Terminal 42 Output Max Scale	100%	All set-ups	FALSE	-2	Uint16
6-96	Terminal 42 Output Bus Control	0 N/A	All set-ups	FALSE	0	Uint16

## 5.1.9 8-\*\* Comm. and Options

Par. No. #	Parameter description	Default value	2-set-up	Change during operation	Conversion index	Type
<b>8-0* General Settings</b>						
8-01	Control site	[0] Digital and ctrl.word	All set-ups	FALSE	-	Uint8
8-02	Control source	[1] FC Port	All set-ups	FALSE	-	Uint8
8-03	Control timeout time	1 s	1 set-up	FALSE	-1	Uint16
8-04	Control timeout function	[0] Off	1 set-up	FALSE	-	Uint8
<b>8-3* FC Port Settings</b>						
8-30	Protocol	[0] FC	1 set-up	FALSE	-	Uint8
8-31	Address	1 N/A	1 set-up	FALSE	0	Uint8
8-32	Baud rate	ExpressionLimit	1 set-up	FALSE	-	Uint8
8-33	Parity/stop bits	ExpressionLimit	1 set-up	FALSE	-	Uint8
8-35	Minimum response delay	0.01 s	1 set-up	FALSE	-3	Uint16
8-36	Maximum response delay	ExpressionLimit	1 set-up	FALSE	-3	Uint16
8-37	Maximum inter-char delay	0.025 s	1 set-up	FALSE	-3	Uint16
<b>8-4* FC MC protocol set</b>						
8-42	PCD write configuration	[0] None	All set-ups	TRUE	-	Uint8
8-43	PCD read configuration	[0] None	1 set-up	TRUE	-	Uint8
<b>8-5* Digital/Bus</b>						
8-50	Coasting select	[3] Logic OR	All set-ups	FALSE	-	Uint8
8-51	Quick stop select	[3] Logic OR	All set-ups	FALSE	-	Uint8
8-52	DC brake select	ExpressionLimit	All set-ups	FALSE	-	Uint8
8-53	Start select	[3] Logic OR	All set-ups	FALSE	-	Uint8
8-54	Reversing select	[0] Digital input	All set-ups	FALSE	-	Uint8
8-55	Set-up select	[3] Logic OR	All set-ups	FALSE	-	Uint8
8-56	Preset reference select	[3] Logic OR	All set-ups	FALSE	-	Uint8
<b>8-7* BACnet</b>						
8-70	BACnet device instance	1 N/A	1 set-up	FALSE	0	Uint32
8-72	MS/TP maximum masters	127 N/A	1 set-up	FALSE	0	Uint8
8-73	MS/TP maximum info frames	1 N/A	1 set-up	FALSE	0	Uint16
8-74	I am service	[0] Send at power-up	1 set-up	FALSE	-	Uint8
8-75	Intialisation password	[admin]	1 set-up	FALSE	0	VisStr[21]
<b>8-8* FC Port Diagnostics</b>						
8-80	Bus message count	0 N/A	1 set-up	FALSE	0	Uint32
8-81	Bus error count	0 N/A	1 set-up	FALSE	0	Uint32
8-82	Slave messages received	0 N/A	1 set-up	FALSE	0	Uint32
8-83	Slave error count	0 N/A	1 set-up	FALSE	0	Uint32
8-84	Slave messages sent	0 N/A	1 set-up	FALSE	0	Uint32
8-85	Slave timeout errors	0 N/A	1 set-up	FALSE	0	Uint32
8-88	Reset FC port diagnostics	[0] Do not reset	1 set-up	FALSE	-	Uint8
<b>8-9* Bus Feedback</b>						
8-94	Bus feedback 1	0 N/A	All set-ups	FALSE	0	Int16
8-95	Bus feedback 2	0 N/A	All set-ups	FALSE	0	Int16



## 5.1.10 13-\*\* Smart Logic

Par. No. #	Parameter description	Default value	2-set-up	Change during operation	Conversion index	Type
<b>13-0* SLC Settings</b>						
13-00	SL Controller Mode	[0] Off	1 set-up	FALSE	-	Uint8
13-01	Start Event	[39] Start command	1 set-up	FALSE	-	Uint8
13-02	Stop Event	[40] Drive stopped	1 set-up	FALSE	-	Uint8
13-03	Reset SLC	[0] Do not reset SLC	1 set-up	FALSE	-	Uint8
<b>13-1* Comparators</b>						
13-10	Comparator Operand	[0] Disabled	1 set-up	FALSE	-	Uint8
13-11	Comparator Operator	[1] Approx.Equal (~)	1 set-up	FALSE	-	Uint8
13-12	Comparator Value	0 N/A	1 set-up	FALSE	-3	Int32
<b>13-2* Timers</b>						
13-20	SL Controller Timer	0 s	1 set-up	FALSE	-2	Uint32
<b>13-4* Logic Rules</b>						
13-40	Logic Rule Boolean 1	[0] False	1 set-up	FALSE	-	Uint8
13-41	Logic Rule Operator 1	[0] Disabled	1 set-up	FALSE	-	Uint8
13-42	Logic Rule Boolean 2	[0] False	1 set-up	FALSE	-	Uint8
13-43	Logic Rule Operator 2	[0] Disabled	1 set-up	FALSE	-	Uint8
13-44	Logic Rule Boolean 3	[0] False	1 set-up	FALSE	-	Uint8
<b>13-5* States</b>						
13-51	SL Controller Event	[0] False	1 set-up	FALSE	-	Uint8
13-52	SL Controller Action	[0] Disabled	1 set-up	FALSE	-	Uint8

## 5.1.11 14-\*\* Special Functions

Par. No. #	Parameter description	Default value	2-set-up	Change during operation	Conversion index	Type
<b>14-0* Inverter Switching</b>						
14-01	Switching Frequency	ExpressionLimit	All set-ups	FALSE	-	Uint8
14-03	Overmodulation	[0] Off	All set-ups	FALSE	-	Uint8
14-07	Dead Time Compensation Level	ExpressionLimit	All set-ups	FALSE	0	Uint8
14-08	Damping Gain Factor	ExpressionLimit	All set-ups	FALSE	0	Uint8
14-09	Dead Time Bias Current Level	ExpressionLimit	All set-ups	FALSE	0	Uint8
<b>14-1* Mains On/Off</b>						
14-10	Mains Failure	[0] No function	All set-ups	FALSE	-	Uint8
14-11	Mains Voltage at Mains Fault	ExpressionLimit	All set-ups	FALSE	0	Uint16
14-12	Function at Mains Imbalance	[0] Trip	1 set-up	FALSE	-	Uint8
<b>14-2* Reset Functions</b>						
14-20	Reset Mode	[0] Manual reset	All set-ups	FALSE	-	Uint8
14-21	Automatic Restart Time	10 s	All set-ups	FALSE	0	Uint16
14-22	Operation Mode	[0] Normal operation	1 set-up	FALSE	-	Uint8
14-27	Action At Inverter Fault	[1] Warning	All set-ups	FALSE	-	Uint8
14-29	Service Code	0 N/A	1 set-up	FALSE	0	Uint32
<b>14-3* Current Limit Ctrl.</b>						
14-30	Current Lim Ctrl, Proportional Gain	100%	All set-ups	FALSE	0	Uint16
14-31	Current Lim Ctrl, Integration Time	ExpressionLimit	All set-ups	FALSE	-3	Uint16
14-32	Current Lim Ctrl, Filter Time	ExpressionLimit	All set-ups	FALSE	-4	Uint16
<b>14-4* Energy Optimization</b>						
14-40	VT Level	90%	All set-ups	FALSE	0	Uint8
14-41	AEO Minimum Magnetisation	66%	All set-ups	FALSE	0	Uint8

Par. No. #	Parameter description	Default value	2-set-up	Change during operation	Conversion index	Type
14-44	d-axis current optimization for IPM	100%	All set-ups	FALSE	0	Uint8
<b>14-5* Environment</b>						
14-51	DC-Link Voltage Compensation	[1] On	All set-ups	FALSE	-	Uint8
14-52	Fan Control	[0] Auto	1 set-up	FALSE	-	Uint8
14-53	Fan Monitor	[1] Warning	1 set-up	FALSE	-	Uint8
14-55	Output Filter	[0] No Filter	1 set-up	FALSE	-	Uint8
<b>14-6* Auto Derate</b>						
14-61	Function at Inverter Overload	[0] Trip	All set-ups	FALSE	-	Uint8
14-63	Min Switch Frequency	[2] 2.0 kHz	1 set-up	FALSE	-	Uint8
14-64	Dead Time Compensation Zero Current Level	[0] Disabled	All set-ups	FALSE	-	Uint8
14-65	Speed Derate Dead Time Compensation	ExpressionLimit	All set-ups	FALSE	0	Uint16
<b>14-9* Fault Settings</b>						
14-90	Fault Level	[3] Trip lock	All set-ups	FALSE	-	Uint8

5.1.12 15-\*\* Drive Information

Par. No. #	Parameter description	Default value	2-set-up	Change during operation	Conversion index	Type
<b>15-0* Operating Data</b>						
15-00	Operating hours	0 h	All set-ups	FALSE	74	Uint32
15-01	Running hours	0 h	All set-ups	FALSE	74	Uint32
15-02	kWh counter	0 kWh	All set-ups	FALSE	75	Uint32
15-03	Power up's	0 N/A	All set-ups	FALSE	0	Uint32
15-04	Over temp's	0 N/A	All set-ups	FALSE	0	Uint16
15-05	Over volt's	0 N/A	All set-ups	FALSE	0	Uint16
15-06	Reset kWh counter	[0] Do not reset	All set-ups	FALSE	-	Uint8
15-07	Reset running hours counter	[0] Do not reset	All set-ups	FALSE	-	Uint8
<b>15-3* Alarm Log</b>						
15-30	Alarm log: error code	0 N/A	All set-ups	FALSE	0	Uint8
15-31	Internal fault reason	0 N/A	1 set-up	FALSE	0	Int16
<b>15-4* Drive Identification</b>						
15-40	FC type	0 N/A	1 set-up	FALSE	0	VisStr[6]
15-41	Power section	0 N/A	1 set-up	FALSE	0	VisStr[20]
15-42	Voltage	0 N/A	1 set-up	FALSE	0	VisStr[20]
15-43	Software version	0 N/A	1 set-up	FALSE	0	VisStr[20]
15-44	Ordered typecode	0 N/A	1 set-up	FALSE	0	VisStr[40]
15-45	Actual typecode string	0 N/A	All set-ups	FALSE	0	VisStr[40]
15-46	Drive ordering no	0 N/A	1 set-up	FALSE	0	VisStr[8]
15-48	LCP ID number	0 N/A	1 set-up	FALSE	0	VisStr[21]
15-49	SW ID control card	0 N/A	1 set-up	FALSE	0	VisStr[21]
15-50	SW ID power card	0 N/A	1 set-up	FALSE	0	VisStr[21]
15-51	Drive serial number	0 N/A	1 set-up	FALSE	0	VisStr[10]
15-53	Power card serial number	0 N/A	1 set-up	FALSE	0	VisStr[20]
15-59	CSIV filename	0 N/A	1 set-up	FALSE	-	VisStr[16]

## 5.1.13 16-\*\* Data Readouts

Par. No. #	Parameter description	Default value	2-set-up	Change during operation	Conversion index	Type
<b>16-0* General Status</b>						
16-00	Control word	0 N/A	1 set-up	FALSE	0	Uint16
16-01	Reference [unit]	0	1 set-up	FALSE	-3	Int32
16-02	Reference [%]	0%	1 set-up	FALSE	-1	Int16
16-03	Status word	0 N/A	1 set-up	FALSE	0	Uint16
16-05	Main actual value [%]	0%	1 set-up	FALSE	-2	Int16
16-09	Custom readout	0 CustomReadoutUnit	1 set-up	FALSE	-2	Int32
<b>16-1* Motor Status</b>						
16-10	Power [kW]	0 kW	1 set-up	FALSE	-3	Uint32
16-11	Power [hp]	0 hp	1 set-up	FALSE	-3	Uint32
16-12	Motor voltage	0 V	1 set-up	FALSE	-1	Uint32
16-13	Frequency	0 Hz	1 set-up	FALSE	-1	Uint32
16-14	Motor current	0 A	1 set-up	FALSE	-2	Uint16
16-15	Frequency [%]	0%	1 set-up	FALSE	-1	Uint16
16-16	Torque [Nm]	0 Nm	All set-ups	FALSE	0	Int32
16-17	Speed [RPM]	0 RPM	1 set-up	FALSE	0	Int32
16-18	Motor thermal	0%	1 set-up	FALSE	0	Uint8
16-22	Torque [%]	0%	All set-ups	FALSE	0	Int16
<b>16-3* Drive Status</b>						
16-30	DC link voltage	0 V	1 set-up	FALSE	0	Uint32
16-34	Heatsink temperature	0 °C	1 set-up	FALSE	100	Int8
16-35	Inverter thermal	0%	1 set-up	FALSE	0	Uint8
16-36	Inverter nominal current	0 A	1 set-up	FALSE	-2	Uint16
16-37	Inverter maximum current	0 A	1 set-up	FALSE	-2	Uint16
16-38	SL controller state	0 N/A	1 set-up	FALSE	0	Uint8
<b>16-5* Ref. &amp; Feedb.</b>						
16-50	External reference	0%	1 set-up	FALSE	-1	Int16
16-52	Feedback[Unit]	0	1 set-up	FALSE	-3	Int32
16-54	Feedback 1 [Unit]	0	All set-ups	FALSE	-3	Int32
16-55	Feedback 2 [Unit]	0	All set-ups	FALSE	-3	Int32
<b>16-6* Inputs &amp; Outputs</b>						
16-60	Digital input	0 N/A	1 set-up	FALSE	0	Uint16
16-61	Terminal 53 setting	[0] Current mode	1 set-up	FALSE	-	Uint8
16-62	Analog input AI53	1 N/A	1 set-up	FALSE	-2	Uint16
16-63	Terminal 54 setting	[0] Current mode	1 set-up	FALSE	-	Uint8
16-64	Analog input AI54	1 N/A	1 set-up	FALSE	-2	Uint16
16-65	Analog output AO42 [mA]	0 mA	1 set-up	FALSE	-2	Uint16
16-66	Digital output	0 N/A	1 set-up	FALSE	0	VisStr[4]
16-67	Pulse input #29 [Hz]	0 N/A	All set-ups	FALSE	0	Int32
16-71	Relay output [bin]	0 N/A	1 set-up	FALSE	0	Uint16
16-72	Counter A	0 N/A	1 set-up	FALSE	0	Int16
16-73	Counter B	0 N/A	1 set-up	FALSE	0	Int16
16-79	Analog output AO45	0 mA	1 set-up	FALSE	-2	Uint16
<b>16-8* Fieldbus &amp; FC Port</b>						
16-86	FC port REF 1	0 N/A	1 set-up	FALSE	0	Int16
<b>16-9* Diagnosis Readouts</b>						
16-90	Alarm word	0 N/A	1 set-up	FALSE	0	Uint32
16-91	Alarm word 2	0 N/A	1 set-up	FALSE	0	Uint32

16-92	Warning word	0 N/A	1 set-up	FALSE	0	Uint32
16-93	Warning word 2	0 N/A	1 set-up	FALSE	0	Uint32
16-94	External status word	0 N/A	1 set-up	FALSE	0	Uint32
16-95	External status word 2	0 N/A	1 set-up	FALSE	0	Uint32

### 5.1.14 18-\*\* Info & Readouts

Par. No. #	Parameter description	Default value	2-set-up	Change during operation	Conversion index	Type
<b>18-1* Fire Mode Log</b>						
18-10	Fire mode log:event	0 N/A	1 set-up	FALSE	0	Uint8
<b>18-5* Ref. &amp; Feedb.</b>						
18-50	Sensorless Readout [unit]	0 SensorlessUnit	1 set-up	FALSE	-3	Int32

5

### 5.1.15 20-\*\* Drive Closed Loop

Par. No. #	Parameter description	Default value	2-set-up	Change during operation	Conversion index	Type
<b>20-0* Feedback</b>						
20-00	Feedback 1 source	[0] No function	All set-ups	FALSE	-	Uint8
20-01	Feedback 1 conversion	[0] Linear	All set-ups	FALSE	-	Uint8
20-03	Feedback 2 source	[0] No function	All set-ups	FALSE	-	Uint8
20-04	Feedback 2 conversion	[0] Linear	All set-ups	FALSE	-	Uint8
<b>20-2* Feedback/Setpoint</b>						
20-20	Feedback function	[3] Minimum	All set-ups	FALSE	-	Uint8
<b>20-8* PI Basic Settings</b>						
20-81	PI normal/inverse control	[0] Normal	All set-ups	FALSE	-	Uint8
20-83	PI start speed [Hz]	0 Hz	All set-ups	FALSE	-1	Uint16
20-84	On reference bandwidth	5%	All set-ups	FALSE	0	Uint8
<b>20-9* PI Controller</b>						
20-91	PI anti windup	[1] On	All set-ups	FALSE	--	Uint8
20-93	PI proportional gain	0.50 N/A	All set-ups	FALSE	-2	Uint16
20-94	PI integral time	20 s	All set-ups	FALSE	-2	Uint32
20-97	PI feed forward factor	0%	All set-ups	FALSE	0	Uint16

## 5.1.16 22-\*\* Appl. Functions

Par. No. #	Parameter description	Default value	2-set-up	Change during operation	Conversion index	Type
<b>22-0* Miscellaneous</b>						
22-01	Power Filter Time	0.50 s	All set-ups	FALSE	-2	Uint16
22-02	Sleep mode CL control mode	[0] Normal	All set-ups	FALSE	-	Uint8
<b>22-2*</b>						
22-23	No-Flow Function	[0] Off	All set-ups	FALSE	-	Uint8
22-24	No-Flow Delay	10 s	All set-ups	FALSE	0	Uint16
<b>22-3*</b>						
22-30	No-Flow Power	0 kW	All set-ups	FALSE	0	Uint32
22-31	Power Correction Factor	100 %	All set-ups	FALSE	0	Uint16
22-33	Low Speed [Hz]	0 Hz	All set-ups	FALSE	0	Uint16
22-34	Low Speed Power [kW]	0 kW	All set-ups	FALSE	0	Uint32
22-37	High Speed [Hz]	0 Hz	All set-ups	FALSE	0	Uint16
22-38	High Speed Power [kW]	0 kW	All set-ups	FALSE	0	Uint32
<b>22-4* Sleep Mode</b>						
22-40	Minimum run time	10 s	All set-ups	FALSE	0	Uint16
22-41	Minimum sleep time	10 s	All set-ups	FALSE	0	Uint16
22-43	Wake-up speed [Hz]	10 N/A	All set-ups	FALSE	-1	Uint16
22-44	Wake-up reference/feedback difference	10%	All set-ups	FALSE	0	Uint8
22-45	Setpoint boost	0%	All set-ups	FALSE	0	Int8
22-46	Maximum boost time	60 s	All set-ups	FALSE	0	Uint16
22-47	Sleep speed [Hz]	0 N/A	All set-ups	FALSE	-1	Uint16
22-48	Sleep delay time	0 s	All set-ups	FALSE	0	Uint16
22-49	Wake-up delay time	0 s	All set-ups	FALSE	0	Uint16
<b>22-6* Broken Belt Detection</b>						
22-60	Broken belt function	[0] Off	All set-ups	FALSE	-	Uint8
22-61	Broken belt torque	10%	All set-ups	FALSE	0	Uint8
22-62	Broken belt delay	10 s	All set-ups	FALSE	0	Uint16
<b>22-8* Flow Compensation</b>						
22-80	Flow Compensation	[0] Disabled	All set-ups	FALSE	-	Uint8
22-81	Square-linear Curve Approximation	100 %	All set-ups	FALSE	0	Uint8
22-82	Work Point Calculation	[0] Disabled	All set-ups	FALSE	-	Uint8
22-84	Speed at No-Flow [Hz]	Expressionlimit (50.0)	All set-ups	FALSE	-1	Uint16
22-86	Speed at Design Point [Hz]	Expressionlimit (50.0)	All set-ups	FALSE	-1	Uint16
22-87	Pressure at No-Flow Speed	0 N/A	All set-ups	FALSE	0	Uint32
22-88	Pressure at Rated Speed	4999.000 N/A	All set-ups	FALSE	-3	Uint32
22-89	Flow at Design Point	0 N/A	All set-ups	FALSE	0	Int32

## 5.1.17 24-\*\* Appl. Functions 2

Par. No. #	Parameter description	Default value	2-set-up	Change during operation	Conversion index	Type
<b>24-0* Fire Mode</b>						
24-00	FM Function	[0] Disabled	1 set-up	FALSE	-	UInt8
24-01	Fire Mode Configuration	[0] Open Loop	All set-ups	FALSE	-	UInt8
24-05	FM Preset Reference	0%	All set-ups	TRUE	0	Int16
24-06	Fire Mode Reference Source	[0] No function	All set-ups	FALSE	-	UInt8
24-07	Fire Mode Feedback Source	[0] No function	All set-ups	FALSE	-	UInt8
24-09	FM Alarm Handling	[1] Trip, Crit.Alarms	1 set-up	FALSE	-	UInt8
<b>24-1* Drive Bypass</b>						
24-10	Drive Bypass Function	[0] Disabled	1 set-up	FALSE	-	UInt8
24-11	Drive Bypass Delay Time	0 s	1 set-up	FALSE	0	UInt16

## 5.1.18 30-\*\* Special Features

Par. No. #	Parameter description	Default value	2-set-up	Change during operation	Conversion index	Type
<b>30-2* Adv. Start Adjust</b>						
30-22	Locked Rotor Detection	[0] Off	All set-ups	FALSE	-	UInt8
30-23	Locked Rotor Detection Time [s]	0.10 s	All set-ups	FALSE	-2	UInt8

## Index

### A

Action at inverter fault.....	76
Active set-up.....	26
Advanced vector control.....	5
AEO.....	76
Alarm.....	98
Alarm and warning list.....	98
Alarm log.....	79
Alarm log: error code.....	79
Alarm log: value.....	79
Alarm word.....	83, 100
Alarm word 2.....	83
Alarm word 3.....	84
Analog output AO42 [mA].....	82
Analog output AO45.....	83
Auto DC braking IT.....	26
Automatic motor adaption.....	34
Automatic restart time.....	75

### B

BACnet.....	64
BACnet device instance.....	64
Baud rate.....	61
Break-away torque.....	5
Broken-belt delay.....	93
Broken-belt detection.....	93
Broken-belt function.....	93
Broken-belt torque.....	93
Bus feedback.....	65

### C

Changes made.....	9
Closed loop.....	29, 95
Closed-loop set-up wizard.....	9
Coast inverse.....	45
Coasting.....	5
Coasting select.....	62
Comparator	
Comparator.....	68
operand.....	68
operator.....	69
value.....	69

### Control

site.....	60
timeout function.....	60
timeout time.....	60
word.....	80

Counter A.....	83
----------------	----

Counter B.....	83
----------------	----

### Current

limit.....	43
Custom readout.....	80
Custom readout unit.....	27

### D

Data readout.....	80
-------------------	----

DC brake current.....	39
-----------------------	----

DC braking time.....	39
----------------------	----

DC hold/motor preheat current.....	39
------------------------------------	----

DC-brake cut-in speed.....	39
----------------------------	----

DC-link compensation.....	77
---------------------------	----

Default setting.....	105
----------------------	-----

Definition.....	5
-----------------	---

Digital input function.....	45
-----------------------------	----

Digital input mode.....	45
-------------------------	----

Digital output.....	83
---------------------	----

Discharge time.....	4
---------------------	---

Display.....	8
--------------	---

Drive bypass.....	96
-------------------	----

Drive closed-loop.....	84
------------------------	----

### E

Energy optimizing.....	76
------------------------	----

Environment.....	77
------------------	----

Extended status word.....	84, 101
---------------------------	---------

Extended status word 2.....	84
-----------------------------	----

External interlock.....	45
-------------------------	----

External reference.....	82
-------------------------	----

### F

Fan control.....	77
------------------	----

Fan monitor.....	77
------------------	----

Fault message.....	101
--------------------	-----

FC port diagnostic.....	64
-------------------------	----

FC port setting.....	60
----------------------	----

Feedback.....	84
---------------	----

Feedback 1 conversion.....	84
----------------------------	----

Feedback 1 source.....	84
------------------------	----

Fieldbus & drive port.....	83
----------------------------	----

Fieldbus & FC port..... 83

Fire mode..... 45

Fire mode log..... 84

Flow compensation..... 93

FM function..... 95

Freeze output..... 5, 45

Frequency..... 81

Frequency [%]..... 81

Frequency converter identification..... 79

Function at mains imbalance..... 75

Function at stop..... 38

Function relay..... 50

**G**

Grid type..... 25

**H**

Hand start..... 45

Heat sink temperature..... 81

High voltage..... 3

**I**

Indicator light..... 8

Initialization..... 24, 76

Initialization, 2-finger..... 24

Inputs

- Analog input..... 5
- Analog input AI53..... 82
- Analog input AI54..... 82
- Digital input..... 45, 82
- Digital input function..... 45
- Digital input mode..... 45

Inverter maximum current..... 82

Inverter nominal current..... 82

Inverter switching..... 74

Inverter thermal..... 81

**J**

Jog..... 5, 45

Jog ramp time..... 42

Jog speed [Hz]..... 41

**K**

Keypad..... 6, 8

Keypad copy..... 28

KWh counter..... 78

**L**

Language..... 25

Latched start..... 45

LCP copy..... 23

Leakage current..... 4

Link set-up..... 27

Live zero..... 54

Load compensation..... 29

Load sharing..... 3

Local reference..... 25

Locked rotor detection..... 97

Locked rotor detection time..... 97

Logic rule..... 69

Logic rule boolean 2..... 71

Logic rule boolean 3..... 72

Logic rule operator 1..... 71

Logic rule operator 2..... 71

**M**

Main actual value..... 80

Main reactance..... 35

Mains

- on/off..... 75

Maximum boost time..... 92

Maximum Inter-char delay..... 61

Maximum output frequency..... 43

Maximum reference..... 40

Maximum response delay..... 61

Menu key..... 8

Minimum reference..... 40

Minimum response delay..... 61

Minimum sleep time..... 92

**Motor**

- control principle..... 29
- current..... 33, 81
- frequency..... 33
- magnetization at 0 speed..... 36
- set-up..... 9
- speed direction..... 42
- speed high limit..... 43
- speed low limit..... 43
- status..... 81
- thermal..... 81
- thermal protection..... 38
- voltage..... 33, 81

**N**

Navigation key..... 8

Nominal motor speed..... 5, 33



NPN..... 45

**O**

Open loop..... 29

Operating data..... 78

Operating hour counter..... 78

Operating mode..... 25

Operating state at power-up..... 25

Operation key..... 8

Operation mode..... 76

Output filter..... 77

Overmodulation..... 74

Overtemperature fault counter..... 79

Overvoltage..... 79

Overvoltage control..... 40

**P**

Parity/stop bit..... 61

Password..... 29

PI anti-windup..... 86

PI basic setting..... 86

PI controller..... 86

PI feed forward factor..... 87

PI integral time..... 87

PI normal/inverse control..... 86

PI proportional gain..... 87

PNP..... 45

Power in hp..... 81

Power in kW..... 81

Power up counter..... 78

Preset ref bit 0..... 45

Preset ref bit 1..... 45

Preset ref bit 2..... 45

Preset reference..... 40

Preset relative reference..... 41

Programming

    Programming..... 8

    set-up..... 27

Protocol..... 60

Pulse input..... 53

**Q**

Quick menu..... 9

Quick stop ramp time..... 42

Quick transfer..... 23

**R**

Ramp 1 ramp-up time..... 42

Ramp 2 ramp-down time..... 42

Ramp 2 ramp-up time..... 42

RCD..... 5

Readout/programming, indexed parameter..... 24

Recommended initialization..... 24

Ref. & Feedb..... 84

Reference 1 source..... 41

Reference 2 source..... 41

Reference 3 source..... 41

Regional setting..... 25

Relay..... 50

Relay output [bin]..... 83

Reset kWh counter..... 79

Reset mode..... 75

Reset SLC..... 68

Resonance dampening..... 37

Reversing..... 45

RFI filter..... 77

Run permissive..... 45

Running hour counter..... 78, 79

**S**

Safety..... 4

Semi-auto bypass set-up..... 45

Sensorless..... 84, 85, 115

Serial communication..... 51

Serial communication port..... 5

Setpoint boost..... 92

Set-up copy..... 29

SL controller action..... 73

SL controller mode..... 66

SL controller timer..... 69

SLC setting..... 66

Sleep mode..... 91

Sleep speed [Hz]..... 92

Slip compensation..... 36

Smart logic..... 66

Smart logic controller event..... 72

Software version..... 79

Special function..... 74

Speed bypass..... 44

Speed down..... 45

Speed up..... 45

Square root.....	84		
Start.....	45	U	
Start delay.....	37	U/f characteristic.....	36
Start event.....	66	Unintended start.....	3
Start function.....	37	V	
Start reversing.....	45	VVC+.....	6
Stator leakage reactance.....	34	W	
Stator resistance.....	34	Warning.....	98
Status menu.....	9	Warning current high.....	44
Status word.....	80	Warning current low.....	44
Stop event.....	67	Warning word.....	84, 100
Switching frequency.....	74	Warning word 2.....	84
		Warning word 3.....	84
T		Wiring schematic.....	7
Terminal 18 digital input.....	47	Wizard, closed-loop set-up.....	9
Terminal 19 digital input.....	48	Wizard, open-loop application.....	9
Terminal 27 digital input.....	49		
Terminal 29 digital input.....	49		
Terminal 42			
Terminal 42 analog output.....	58		
Terminal 42 digital output.....	58		
Terminal 42 mode.....	58		
Terminal 42 output maximum scale.....	59		
Terminal 42 output minimum scale.....	59		
Terminal 45			
Terminal 45 analog output.....	56		
Terminal 45 digital output.....	57		
Terminal 45 mode.....	56		
Terminal 45 output bus control.....	58		
Terminal 45 output max scale.....	58		
Terminal 45 output min scale.....	58		
Terminal 53			
Terminal 53 filter time constant.....	55		
Terminal 53 high current.....	55		
Terminal 53 high voltage.....	55		
Terminal 53 low current.....	55		
Terminal 53 low voltage.....	55		
Terminal 53 mode.....	56		
Terminal 53 setting.....	82		
Terminal 54			
Terminal 54 filter time constant.....	56		
Terminal 54 high current.....	56		
Terminal 54 high voltage.....	56		
Terminal 54 low current.....	56		
Terminal 54 low voltage.....	56		
Terminal 54 mode.....	56		
Terminal 54 setting.....	82		
Thermal load.....	36		
Thermistor.....	5		
Thermistor source.....	39		
Timer.....	69		
Trip reset.....	75		



Ingersoll Rand (NYSE:IR) advances the quality of life by creating comfortable, sustainable and efficient environments. Our people and our family of brands—including Club Car®, Ingersoll Rand®, Thermo King® and Trane®—work together to enhance the quality and comfort of air in homes and buildings; transport and protect food and perishables; and increase industrial productivity and efficiency. We are a global business committed to a world of sustainable progress and enduring results.



[ingersollrand.com](http://ingersollrand.com)

Ingersoll Rand has a policy of continuous product and product data improvement and reserves the right to change design and specifications without notice.  
We are committed to using environmentally conscious print practices.

BAS-SVP16C-EN 20 Jan 2019  
Supersedes BAS-SVP16B-EN (Feb 2017)

©2019 Ingersoll Rand

