

## Safety

### Safety

#### **⚠ WARNING**

##### HIGH VOLTAGE!

Adjustable frequency drives contain high voltage when connected to AC line power. Installation, start-up, and maintenance should be performed by qualified personnel only. Failure to perform installation, start-up, and maintenance by qualified personnel could result in death or serious injury.

##### High Voltage

Adjustable frequency drives are connected to hazardous AC line voltage. Extreme care should be taken to protect against shock. Only trained personnel familiar with electronic equipment should install, start, or maintain this equipment.

#### **⚠ WARNING**

##### UNINTENDED START!

When the adjustable frequency drive is connected to AC line power, the motor may start at any time. The adjustable frequency drive, motor, and any driven equipment must be in operational readiness. Failure to be in operational readiness when the adjustable frequency drive is connected to AC line power could result in death, serious injury, equipment, or property damage.

##### Unintended Start

When the adjustable frequency drive is connected to the AC line power, the motor may be started by means of an external switch, a serial bus command, an input reference signal, or a cleared fault condition. Use appropriate caution to guard against an unintended start.

#### **⚠ WARNING**

##### DISCHARGE TIME!

Adjustable frequency drives contain DC link capacitors that can remain charged even when the adjustable frequency drive is not powered. To avoid electrical hazards, disconnect AC line power, any permanent magnet type motors, and any remote DC link power supplies, including battery backups, UPS and DC link connections to other adjustable frequency drives. Wait for the capacitors to fully discharge before performing any service or repair work. The wait time required is listed in the *Discharge Time* table. Failure to wait for the specified period of time after power has been removed to do service or repair could result in death or serious injury.

Voltage [V]	Minimum Waiting Time [Minutes]		
	4	7	15
200–240	0.34–5 hp [0.25–3.7 kW]		7.5–60 hp [5.5–45 kW]
380–480	0.5–10 hp [0.37–7.5 kW]		15–125 hp [11–90 kW]
525–600	1–10 hp [0.75–7.5 kW]		15–125 hp [11–90 kW]
525–690		1.5–10 hp [1.1–7.5 kW]	15–125 hp [11–90 kW]
High voltage may be present even when the warning LED display lights are off.			

##### Discharge Time

##### Symbols

The following symbols are used in this manual.

#### **⚠ WARNING**

Indicates a potentially hazardous situation which, if not avoided, could result in death or serious injury.

#### **⚠ CAUTION**

Indicates a potentially hazardous situation which, if not avoided, may result in minor or moderate injury. It may also be used to alert against unsafe practices.

## CAUTION

Indicates a situation that may result in equipment or property damage-only accidents.

## NOTE!

Indicates highlighted information that should be observed in order to avoid mistakes or operate equipment at less than optimal performance.



Approvals

## NOTE!

Imposed limitations on the output frequency  
(due to export control regulations):

From software version 1.99, the output frequency of the adjustable frequency drive is limited to 590 Hz. Software versions 1x.xx also limit the maximum output frequency to 590 Hz, but these versions cannot be flashed, i.e., neither downgraded nor upgraded.

## Contents

<b>1 Introduction</b>	2-1
1.1 Purpose of the Manual	2-3
1.2 Additional Resources	2-3
1.3 Product Overview	2-3
1.4 Internal Component Functions	2-4
1.5 Frame Sizes and Power Ratings	2-5
1.6 Safe Stop	2-5
1.6.1 Terminal 37 Safe Stop Function	2-6
1.6.2 Safe Stop Commissioning Test	2-8
<b>2 Installation</b>	3-1
2.1 Installation Site Checklist	3-1
2.2 Adjustable Frequency Drive and Motor Pre-installation Checklist	3-1
2.3 Mechanical Installation	3-1
2.3.1 Cooling	3-1
2.3.2 Lifting	3-2
2.3.3 Mounting	3-2
2.3.4 Tightening Torques	3-2
2.4 Electrical Installation	3-3
2.4.1 Requirements	3-5
2.4.2 Grounding Requirements	3-5
2.4.2.1 Leakage Current (>3.5 mA)	3-6
2.4.2.2 Grounding Using Shielded Cable	3-6
2.4.3 Motor Connection	3-6
2.4.4 AC Line Input Connection	3-8
2.4.5 Control Wiring	3-8
2.4.5.1 Access	3-8
2.4.5.2 Control Terminal Types	3-9
2.4.5.3 Wiring to Control Terminals	3-10
2.4.5.4 Using Shielded Control Cables	3-11
2.4.5.5 Control Terminal Functions	3-11
2.4.5.6 Jumper Terminals 12 and 27	3-11
2.4.5.7 Terminal 53 and 54 Switches	3-12
2.4.5.8 Mechanical Brake Control	3-12
2.4.6 Serial Communication	3-13
<b>3 Start-up and Functional Testing</b>	4-1
3.1 Pre-start	4-1

3.1.1 Safety Inspection	4-1
3.2 Applying Power to the Adjustable Frequency Drive	4-3
3.3 Basic Operational Programming	4-3
3.3.1 Required Initial Adjustable Frequency Drive Programming	4-3
3.4 PM Motor Set-up in VVCplus	4-4
3.5 Automatic Motor Adaptation	4-5
3.6 Check Motor Rotation	4-6
3.7 Local Control Test	4-6
3.8 System Start-up	4-7
3.9 Acoustic Noise or Vibration	4-7
<b>4 User Interface</b>	<b>5-1</b>
4.1 Local Control Panel	5-1
4.1.1 LCP Layout	5-1
4.1.2 Setting LCP Display Values	5-2
4.1.3 Display Menu Keys	5-2
4.1.4 Navigation Keys	5-3
4.1.5 Operation Keys	5-3
4.2 Backup and Copying Parameter Settings	5-3
4.2.1 Uploading Data to the LCP	5-4
4.2.2 Downloading Data from the LCP	5-4
4.3 Restoring Default Settings	5-4
4.3.1 Recommended Initialization	5-4
4.3.2 Manual Initialization	5-4
<b>5 About Adjustable Frequency Drive Programming</b>	<b>6-1</b>
5.1 Introduction	6-1
5.2 Programming Example	6-1
5.3 Control Terminal Programming Examples	6-3
5.4 International/North American Default Parameter Settings	6-3
5.5 Parameter Menu Structure	6-4
5.5.1 Quick Menu Structure	6-5
5.5.2 Main Menu Structure	6-7
5.6 Remote Programming with MCT 10 Set-up Software	6-11
<b>6 Application Set-up Examples</b>	<b>7-1</b>
6.1 Introduction	7-1
6.2 Application Examples	7-1
<b>7 Status Messages</b>	<b>8-1</b>

---

7.1 Status Display	8-1
7.2 Status Message Definitions	8-1
<b>8 Warnings and Alarms</b>	<b>9-1</b>
8.1 System Monitoring	9-1
8.2 Warning and Alarm Types	9-1
8.3 Warning and Alarm Displays	9-1
8.4 Warning and Alarm Definitions	9-3
<b>9 Basic Troubleshooting</b>	<b>10-1</b>
9.1 Start-up and Operation	10-1
<b>10 Specifications</b>	<b>11-1</b>
10.1 Power-dependent Specifications	11-1
10.2 General Technical Data	11-12
10.3 Fuse Specifications	11-17
10.3.1 CE Compliance	11-17
10.3.2 Fuse Tables	11-17
10.3.3 UL Compliance	11-21
10.4 Connection Tightening Torques	11-27
<b>12 Index</b>	<b>12-1</b>



# 1 Introduction

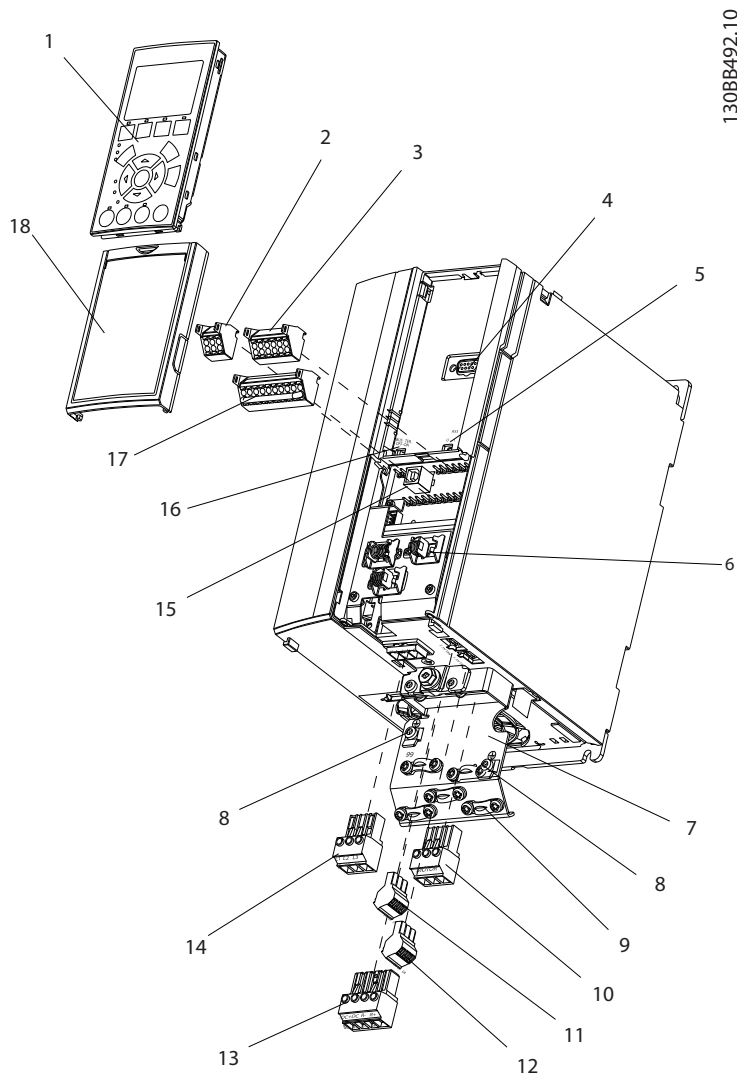
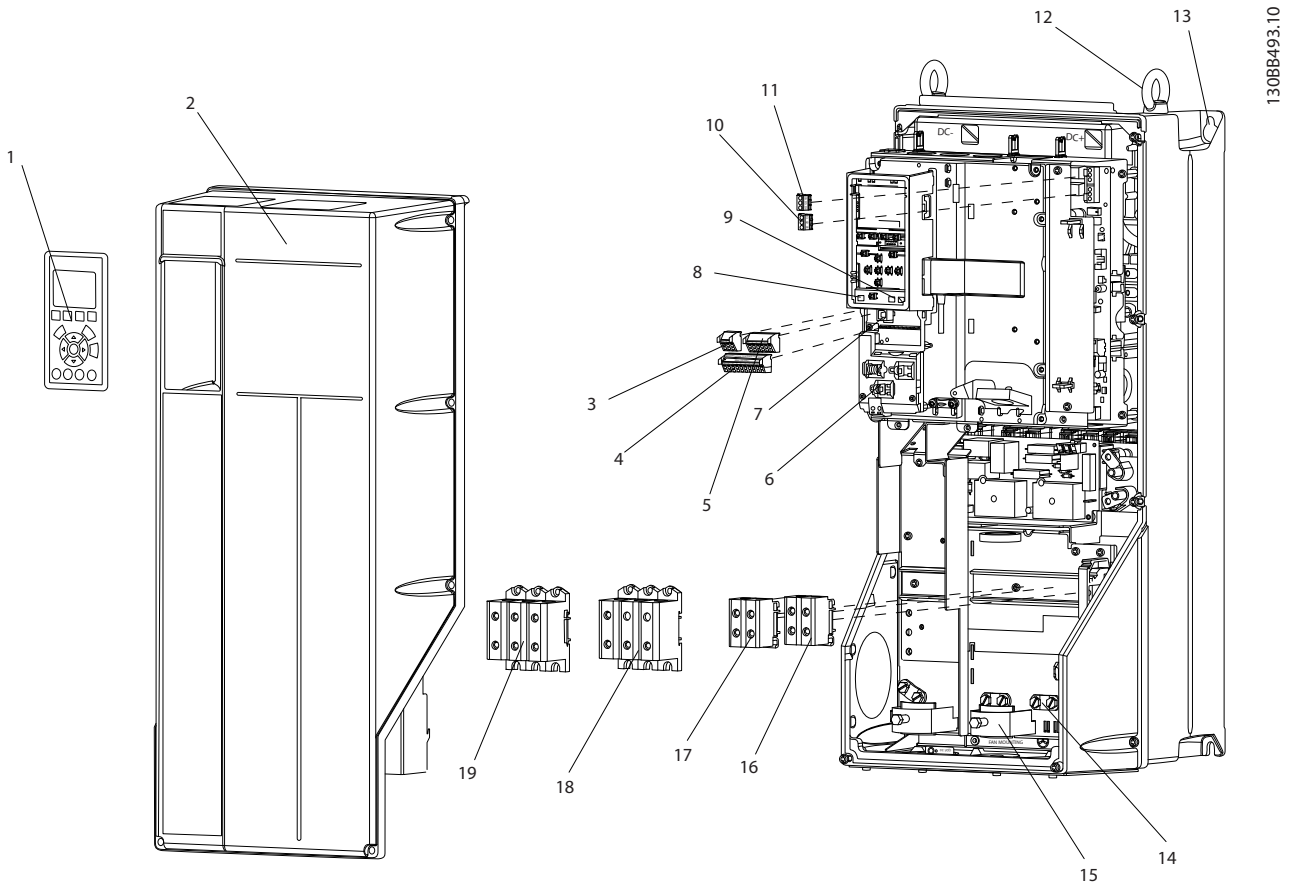

Figure 1.1 Exploded View A Size

1	LCP	10	Motor output terminals 96 (U), 97 (V), 98 (W)
2	RS-485 serial bus connector (+68, -69)	11	Relay 2 (01, 02, 03)
3	Analog I/O connector	12	Relay 1 (04, 05, 06)
4	LCP input plug	13	Brake (-81, +82) and load sharing (-88, +89) terminals
5	Analog switches (A53), (A54)	14	Line power input terminals 91 (L1), 92 (L2), 93 (L3)
6	Cable strain relief/PE ground	15	USB connector
7	Decoupling plate	16	Serial bus terminal switch
8	Grounding clamp (PE)	17	Digital I/O and 24 V power supply
9	Shielded cable grounding clamp and strain relief	18	Control cable cover plate

Table 1.1 Legend to Figure 1.1



1308B493.10

Figure 1.2 Exploded View B and C Sizes

1	LCP	11	Relay 2 (04, 05, 06)
2	Cover	12	Lifting ring
3	RS-485 serial bus connector	13	Mounting slot
4	Digital I/O and 24 V power supply	14	Grounding clamp (PE)
5	Analog I/O connector	15	Cable strain relief / PE ground
6	Cable strain relief/PE ground	16	Brake terminal (-81, +82)
7	USB connector	17	Load sharing terminal (DC bus) (-88, +89)
8	Serial bus terminal switch	18	Motor output terminals 96 (U), 97 (V), 98 (W)
9	Analog switches (A53), (A54)	19	Line power input terminals 91 (L1), 92 (L2), 93 (L3)
10	Relay 1 (01, 02, 03)		

Table 1.2 Legend to Figure 1.2



## 1.1 Purpose of the Manual

This manual is intended to provide detailed information for the installation and of the adjustable frequency drive.

2 *Installation* provides requirements for mechanical and electrical installation, including input, motor, control and serial communications wiring, and control terminal functions. 3 *Start-up and Functional Testing* provides detailed procedures for start-up, basic operational programming, and functional testing. The remaining chapters provide supplementary details. These include user interface, detailed programming, application examples, start-up troubleshooting, and specifications.

## 1.2 Additional Resources

Other resources are available to understand advanced adjustable frequency drive functions and programming.

- The *VLT® Programming Guide* provides greater detail on working with parameters and many application examples.
- The *VLT® Design Guide* provides detailed capabilities and functionality to design motor control systems.
- Supplementary publications and manuals are available from Danfoss. See [www.danfoss.com/BusinessAreas/DrivesSolutions/Documentations/VLT+Technical+Documentation.htm](http://www.danfoss.com/BusinessAreas/DrivesSolutions/Documentations/VLT+Technical+Documentation.htm) for listings.
- Optional equipment that may change some of the procedures described is available. Reference the instructions supplied with those options for specific requirements. Contact the local Danfoss supplier or visit the Danfoss website: [www.danfoss.com/BusinessAreas/DrivesSolutions/Documentations/VLT+Technical+Documentation.htm](http://www.danfoss.com/BusinessAreas/DrivesSolutions/Documentations/VLT+Technical+Documentation.htm) for downloads or additional information.

## 1.3 Product Overview

An adjustable frequency drive is an electronic motor controller that converts AC line power input into a variable AC waveform output. The frequency and voltage of the output are regulated to control the motor speed or torque. The adjustable frequency drive can vary the speed of the motor in response to system feedback, such as changing temperature or pressure for controlling fan, compressor, or pump motors. The adjustable frequency drive can also regulate the motor by responding to remote commands from external controllers.

In addition, the adjustable frequency drive monitors the system and motor status, issues warnings or alarms for fault conditions, starts and stops the motor, optimizes energy efficiency, and offers many more control, monitoring, and efficiency functions. Operation and monitoring functions are available as status indications to an outside control system or serial communication network.

For single phase adjustable frequency drives (S2 and S4) installed in the EU, the following applies:

Single phase adjustable frequency drives (S2 and S4) with an input current less than 16 A and an input of more than 1 kW are intended for use as professional equipment in trades, professions, or industries. Designated application areas are:

- Public pools, public water supplies, agriculture, commercial buildings and industries.

They are not intended for general public use or use in residential areas. All other single phase adjustable frequency drives are only intended for use in private low-voltage systems interfacing with public supply only at a medium or high voltage level. Operators of private systems must ensure that the EMC environment complies with IEC 61000-3-6 and/or the contractual agreements.

### 1.4 Internal Component Functions

Figure 1.3 is a block diagram of the adjustable frequency drive's internal components. See Table 1.3 for their functions.

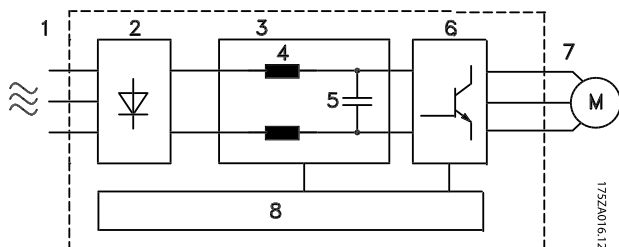

Figure 1.3 Adjustable Frequency Drive Block Diagram

Area	Title	Functions
8	Control circuitry	<ul style="list-style-type: none"> <li>• Input power, internal processing, output, and motor current are monitored to provide efficient operation and control</li> <li>• User interface and external commands are monitored and performed</li> <li>• Status output and control can be provided</li> </ul>

Table 1.3 Legend to Figure 1.3

Area	Title	Functions
1	Line power input	<ul style="list-style-type: none"> <li>• Three-phase AC line power supply to the adjustable frequency drive</li> </ul>
2	Rectifier	<ul style="list-style-type: none"> <li>• The rectifier bridge converts the AC input to DC current to supply inverter power</li> </ul>
3	DC bus	<ul style="list-style-type: none"> <li>• Intermediate DC bus circuit handles the DC current</li> </ul>
4	DC reactors	<ul style="list-style-type: none"> <li>• Filter the intermediate DC circuit voltage</li> <li>• Provide line transient protection</li> <li>• Reduce RMS current</li> <li>• Raise the power factor reflected back to the line</li> <li>• Reduce harmonics on the AC input</li> </ul>
5	Capacitor bank	<ul style="list-style-type: none"> <li>• Stores the DC power</li> <li>• Provides ride-through protection for short power losses</li> </ul>
6	Inverter	<ul style="list-style-type: none"> <li>• Converts the DC into a controlled PWM AC waveform for a controlled variable output to the motor</li> </ul>
7	Output to motor	<ul style="list-style-type: none"> <li>• Regulated three-phase output power to the motor</li> </ul>

## 1.5 Frame Sizes and Power Ratings

References to frame sizes used in this manual are defined in *Table 1.4*.

Volts [V]	Frame Size (hp [kW])											
	A2	A3	A4	A5	B1	B2	B3	B4	C1	C2	C3	C4
200–240	0.34–3 [0.25–2.2]	4–5 [3.0–3.7]	0.34–3 [0.25–2.2]	0.34–5 [0.25–3.7]	7.5–15 [5.5–11]	20 [15]	7.5–15 [5.5–11]	20–25 [15–18.5]	25–40 [18.5–30]	50–60 [37–45]	30–40 [22–30]	50–60 [37–45]
380–480	0.5–5 [0.37–4.0]	7.5–10 [5.5–7.5]	0.5–5 [0.37–4.0]	0.5–10 [0.37–7.5]	15–25 [11–18.5]	30–40 [22–30]	15–25 [11–18.5]	30–50 [22–37]	50–75 [37–55]	100–125 [75–90]	60–75 [45–55]	100–125 [75–90]
525–600	n/a	1–10 [0.75–7.5]	n/a	1–10 [0.75–7.5]	15–25 [11–18.5]	30–40 [22–30]	15–25 [11–18.5]	30–50 [22–37]	50–75 [37–55]	100–125 [75–90]	60–75 [45–55]	100–125 [75–90]
525–690	n/a	1.5–10 [1.1–7.5]	n/a	n/a	n/a	15–40 [11–30]	n/a	n/a	n/a	50–125 [37–90]	60–75 [45–55]	n/a
<b>Single phase</b>												
200–240	n/a	1.5 [1.1]	n/a	1.5 [1.1]	2–7.5 [1.5–5.5]	10 [7.5]	n/a	n/a	20 [15]	30 [22]	n/a	n/a
380–480	n/a	n/a	n/a	n/a	10 [7.5]	15 [11]	n/a	n/a	25 [18.5]	50 [37]	n/a	n/a

Table 1.4 Frame Sizes and Power Ratings

## 1.6 Safe Stop

The adjustable frequency drive can perform the safety function *Safe Torque Off (STO)*, as defined by EN IEC 61800-5-2<sup>1)</sup> and *Stop Category 0* (as defined in EN 60204-1<sup>2)</sup>).

Danfoss has named this functionality *Safe Stop*. Before integration and use of Safe Stop in an installation, perform a thorough risk analysis to determine whether the Safe Stop functionality and safety levels are appropriate and sufficient. Safe Stop is designed and approved suitable for the requirements of:

- Safety Category 3 according to EN ISO 13849-1
- Performance Level "d" according to EN ISO 13849-1:2008
- SIL 2 Capability according to IEC 61508 and EN 61800-5-2
- SILCL 2 according to EN 62061

<sup>1)</sup> Refer to EN IEC 61800-5-2 for details of Safe torque off (STO) function.

<sup>2)</sup> Refer to EN IEC 60204-1 for details of stop category 0 and 1.

### Activation and Termination of Safe Stop

The Safe Stop (STO) function is activated by removing the voltage at Terminal 37 of the Safe Inverter. By connecting the Safe Inverter to external safety devices providing a safe delay, an installation for a safe Stop Category 1 can be

obtained. The Safe Stop function can be used for asynchronous, synchronous, and permanent magnet motors.

### **WARNING**

**After installation of Safe Stop (STO), a commissioning test as specified in 1.6.2 Safe Stop Commissioning Test must be performed. A passed commissioning test is mandatory after first installation and after each change to the safety installation.**

### Safe Stop Technical Data

The following values are associated to the different types of safety levels:

#### Reaction time for T37

- Maximum reaction time: 10 ms

Reaction time = delay between de-energizing the STO input and switching off the adjustable frequency drive output bridge.

#### Data for EN ISO 13849-1

- Performance Level "d"
- MTTF<sub>d</sub> (Mean Time To Dangerous Failure): 14,000 years
- DC (Diagnostic Coverage): 90%
- Category 3
- Lifetime 20 years

**Data for EN IEC 62061, EN IEC 61508, EN IEC 61800-5-2**

- SIL 2 Capability, SILCL 2
- PFH (Probability of Dangerous failure per Hour)= $1e-10$  FIT= $7e-19$ /h/h>90%
- SFF (Safe Failure Fraction) >99%
- HFT (Hardware Fault Tolerance)=0 (1001 architecture)
- Lifetime 20 years

**Data for EN IEC 61508 low demand**

- PFDavg for one year proof test: 1E-10
- PFDavg for three year proof test: 1E-10
- PFDavg for five year proof test: 1E-10

No maintenance of the STO functionality is needed.

Security measures have to be taken by the user, e.g., installation in a closed cabinet that is only accessible for skilled personnel.

**SISTEMA Data**

Functional safety data is available via a data library for use with the SISTEMA calculation tool from the IFA (Institute for Occupational Safety and Health of the German Social Accident Insurance) and data for manual calculation. The library is complete and continually extended.

### 1.6.1 Terminal 37 Safe Stop Function

The adjustable frequency drive is available with safe stop functionality via control terminal 37. Safe stop disables the control voltage of the power semiconductors of the adjustable frequency drive output stage. This in turn prevents generating the voltage required to rotate the motor. When the Safe Stop (T37) is activated, the adjustable frequency drive issues an alarm, trips the unit, and coasts the motor to a stop. Manual restart is required. The safe stop function can be used as an emergency stop for the adjustable frequency drive. In normal operating mode when safe stop is not required, use the regular stop function instead. When automatic restart is used, ensure the requirements of ISO 12100-2 paragraph 5.3.2.5 are fulfilled.

**Liability Conditions**

It is the responsibility of the user to ensure that qualified personnel installs and operates the safe stop function:

- Read and understand the safety regulations concerning health and safety/accident prevention
- Understand the generic and safety guidelines given in this description and the extended description in the relevant *Design Guide*
- Have a good knowledge of the generic and safety standards applicable to the specific application

User is defined as: integrator, operator, service technician, maintenance technician.

**Standards**

Use of safe stop on terminal 37 requires that the user satisfies all provisions for safety including relevant laws, regulations and guidelines. The optional safe stop function complies with the following standards.

- IEC 60204-1: 2005 category 0 – uncontrolled stop
- IEC 61508: 1998 SIL2
- IEC 61800-5-2: 2007 – safe torque off (STO) function
- IEC 62061: 2005 SIL CL2
- ISO 13849-1: 2006 Category 3 PL d
- ISO 14118: 2000 (EN 1037) – prevention of unexpected start-up

The information and instructions of the instruction manual are not sufficient for a proper and safe use of the safe stop functionality. The related information and instructions of the relevant *Design Guide* must be followed.

**Protective Measures**

- Qualified and skilled personnel are required for installation and commissioning of safety engineering systems
- The unit must be installed in an IP54 cabinet or in an equivalent environment. In special applications, a higher IP degree is required
- The cable between terminal 37 and the external safety device must be short circuit protected according to ISO 13849-2 table D.4
- When external forces influence the motor axis (for example, suspended loads), additional measures are required (for example, a safety holding brake) to eliminate potential hazards

Safe Stop Installation and Set-up

**WARNING**

**SAFE STOP FUNCTION!**

The safe stop function does NOT isolate AC line voltage to the adjustable frequency drive or auxiliary circuits. Perform work on electrical parts of the adjustable frequency drive or the motor only after isolating the AC line voltage supply and waiting the length of time specified in *Table 1.1*.

Failure to isolate the AC line voltage supply from the unit and waiting the time specified could result in death or serious injury.

- It is not recommended to stop the adjustable frequency drive by using the Safe Torque Off function. If a running adjustable frequency drive is stopped by using the function, the unit trips and stops by coasting. If unacceptable or dangerous, use another stopping mode to stop the adjustable frequency drive and machinery, before using this function. Depending on the application, a mechanical brake can be required.
- For synchronous and permanent magnet motor adjustable frequency drives, in a multiple IGBT power semiconductor failure: In spite of the activation of the Safe Torque Off function, the system can produce an alignment torque which maximally rotates the motor shaft by 180/p degrees. p denotes the pole pair number.
- This function is suitable for performing mechanical work on the system or affected area of a machine only. It does not provide electrical safety. Do not use this function as a control for starting and/or stopping the adjustable frequency drive.

Follow these steps to perform a safe installation of the adjustable frequency drive:

1. Remove the jumper wire between control terminals 37 and 12 or 13. Cutting or breaking the jumper is not sufficient to avoid short-circuiting. (See jumper on *Figure 1.4*.)
2. Connect an external Safety monitoring relay via a NO safety function to terminal 37 (safe stop) and either terminal 12 or 13 (24 V DC). Follow the instructions for the safety device. The Safety monitoring relay must comply with Category 3 /PL "d" (ISO 13849-1) or SIL 2 (EN 62061).

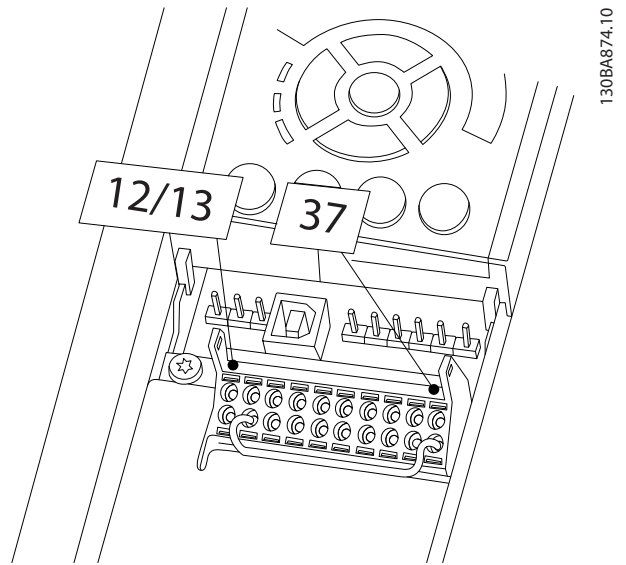

Figure 1.4 Jumper between Terminal 12/13 (24 V) and 37

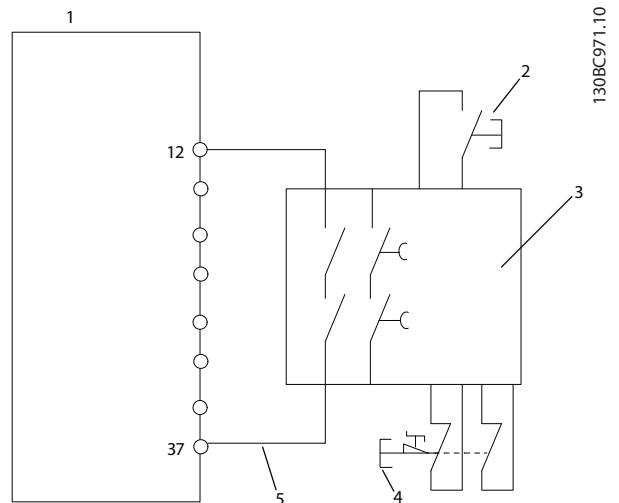

Figure 1.5 Installation to Achieve a Stopping Category 0 (EN 60204-1) with Cat. 3 /PL "d" (ISO 13849-1) or SIL 2 (EN 62061).

1	Adjustable frequency drive
2	[Reset] key
3	Safety relay (cat. 3, PL d or SIL2)
4	Emergency stop button
5	Short-circuit protected cable (if not inside installation IP54 cabinet)

Table 1.5 Legend to *Figure 1.5*

### Safe Stop Commissioning Test

After installation and before first operation, perform a commissioning test of the installation using safe stop. Also, perform the test after each modification of the installation.

#### **⚠ WARNING**

Safe Stop activation (that is removal of 24 V DC voltage supply to terminal 37) does not provide electrical safety. The Safe Stop function itself is therefore not sufficient to implement the Emergency-Off function as defined by EN 60204-1. Emergency-Off requires measures of electrical isolation, for example, by switching off line power via an additional contactor.

1. Activate the Safe Stop function by removing the 24 V DC voltage supply to the terminal 37.
2. After activation of Safe Stop (that is, after the response time), the adjustable frequency drive coasts (stops creating a rotational field in the motor). The response time is typically less than 10 ms.

The adjustable frequency drive is guaranteed not to restart creation of a rotational field by an internal fault (in accordance with Cat. 3 PL d acc. EN ISO 13849-1 and SIL 2 acc. EN 62061). After activation of Safe Stop, the display shows the text "Safe Stop activated". The associated help text says, "Safe Stop has been activated". This means that the Safe Stop has been activated, or that normal operation has not been resumed yet after Safe Stop activation.

#### **NOTE!**

The requirements of Cat. 3 /PL "d" (ISO 13849-1) are only fulfilled while 24 V DC supply to terminal 37 is kept removed or low by a safety device which itself fulfills Cat. 3 PL "d" (ISO 13849-1). If external forces act on the motor, it must not operate without additional measures for fall protection. External forces can arise for example, in the event of vertical axis (suspended loads) where an unwanted movement, for example caused by gravity, could cause a hazard. Fall protection measures can be additional mechanical brakes.

By default the Safe Stop function is set to an Unintended Restart Prevention behavior. Therefore, to resume operation after activation of Safe Stop,

1. reapply 24 V DC voltage to terminal 37 (text Safe Stop activated is still displayed)
2. create a reset signal (via bus, digital I/O, or [Reset] key).

The Safe Stop function can be set to an Automatic Restart behavior. Set the value of *5-19 Terminal 37 Digital Input* from default value [1] to value [3].

Automatic Restart means that Safe Stop is terminated, and normal operation is resumed, as soon as the 24 V DC are applied to Terminal 37. No Reset signal is required.

#### **⚠ WARNING**

Automatic Restart Behavior is permitted in one of the two situations:

1. Unintended restart prevention is implemented by other parts of the safe stop installation.
2. A presence in the hazard zone can be physically excluded when safe stop is not activated. In particular, paragraph 5.3.2.5 of ISO 12100-2 2003 must be observed

### 1.6.2 Safe Stop Commissioning Test

After installation and before first operation, perform a commissioning test of an installation or application, using Safe Stop.

Perform the test again after each modification of the installation or application involving the Safe Stop.

#### **NOTE!**

A passed commissioning test is mandatory after first installation and after each change to the safety installation.

The commissioning test (select one of cases 1 or 2 as applicable):

**Case 1: Restart prevention for Safe Stop is required (that is Safe Stop only where *5-19 Terminal 37 Digital Input* is set to default value [1], or combined Safe Stop and MCB 112 where *5-19 Terminal 37 Digital Input* is set to [6] PTC 1 & Relay A or [9] PTC 1 & Relay W/A):**

1.1 Remove the 24 V DC voltage supply to terminal 37 using the interrupt device while the adjustable frequency drive drives the motor (that is line power supply is not interrupted). The test step is passed when

- the motor reacts with a coast, and
- the mechanical brake is activated (if connected)
- the alarm "Safe Stop [A68]" is displayed in the LCP, if mounted

1.2 Send Reset signal (via bus, digital I/O, or [Reset] key). The test step is passed if the motor remains in the safe stop state, and the

mechanical brake (if connected) remains activated.

1.3 Reapply 24 V DC to terminal 37. The test step is passed if the motor remains in the coasted state, and the mechanical brake (if connected) remains activated.

1.4 Send Reset signal (via bus, digital I/O, or [Reset] key). The test step is passed when the motor becomes operational again.

The commissioning test is passed if all four test steps 1.1, 1.2, 1.3 and 1.4 are passed.

**Case 2: Automatic Restart of Safe Stop is wanted and allowed (that is, Safe Stop only where 5-19 Terminal 37 Digital Input is set to [3], or combined Safe Stop and MCB 112 where 5-19 Terminal 37 Digital Input is set to [7] PTC 1 & Relay W or [8] PTC 1 & Relay A/W):**

2.1 Remove the 24 V DC voltage supply to terminal 37 by the interrupt device while the adjustable frequency drive drives the motor (that is line power supply is not interrupted). The test step is passed when

- the motor reacts with a coast, and
- the mechanical brake is activated (if connected)
- the alarm "Safe Stop [A68]" is displayed in the LCP, if mounted

2.2 Reapply 24 V DC to terminal 37.

The test step is passed if the motor becomes operational again. The commissioning test is passed if both test steps 2.1 and 2.2 are passed.

## NOTE!

See warning on the restart behavior in *1.6.1 Terminal 37 Safe Stop Function*

## WARNING

The Safe Stop function can be used for asynchronous, synchronous and permanent magnet motors. Two faults can occur in the power semiconductor of the adjustable frequency drive. When using synchronous or permanent magnet motors a residual rotation can result from the faults. The rotation can be calculated to  $\text{Angle} = 360 / (\text{Number of Poles})$ . The application using synchronous or permanent magnet motors must take this residual rotation into consideration and ensure that it does not pose a safety risk. This situation is not relevant for asynchronous motors.





## 2 Installation

### 2.1 Installation Site Checklist

- The adjustable frequency drive relies on the ambient air for cooling. Observe the limitations on ambient air temperature for optimal operation
- Ensure that the installation location has sufficient support strength to mount the adjustable frequency drive
- Keep the manual, drawings, and diagrams accessible for detailed installation and operation instructions. It is important that the manual is available for equipment operators.
- Locate equipment as near to the motor as possible. Keep motor cables as short as possible. Check the motor characteristics for actual tolerances. Do not exceed
  - 1,000 ft [300 m] for unshielded motor leads
  - 500 ft [150 m] for shielded cable.
- Ensure that the ingress protection rating of the adjustable frequency drive is suitable for the installation environment. IP55 (NEMA 12) or IP66 (NEMA 4) enclosures may be necessary.

#### CAUTION

##### Ingress protection

IP54, IP55 and IP66 ratings can only be guaranteed if the unit is properly closed.

- Ensure that all cable connectors and unused holes for connectors are properly sealed.
- Ensure that the unit cover is properly closed

#### CAUTION

##### Device damage through contamination

Do not leave the adjustable frequency drive uncovered.

### 2.2 Adjustable Frequency Drive and Motor Pre-installation Checklist

- Compare the model number of unit on the nameplate to what was ordered to verify the proper equipment
- Ensure each of the following are rated for the same voltage:
  - Line power
  - Adjustable frequency drive
  - Motor
- Ensure that the adjustable frequency drive output current rating is equal to or greater than motor full load current for peak motor performance.
  - Motor size and adjustable frequency drive power must match for proper overload protection
  - If adjustable frequency drive rating is less than motor, full motor output cannot be achieved

### 2.3 Mechanical Installation

#### 2.3.1 Cooling

- To provide cooling airflow, mount the unit to a solid flat surface or to the optional backplate (see *2.3.3 Mounting*)
- Top and bottom clearance for air cooling must be provided. Generally, 100–225 mm (4–10 in) is required. See *Figure 2.1* for clearance requirements
- Improper mounting can result in overheating and reduced performance.
- Derating for temperatures starting between 104 °F [40 °C] and 122 °F [50 °C] and elevation 3300 ft [1000 m] above sea level must be considered. See the equipment Design Guide for detailed information.

2

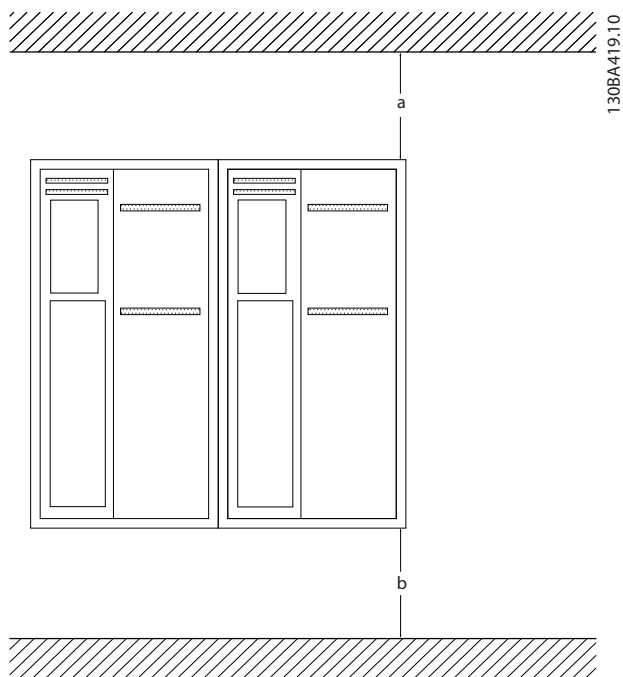

Figure 2.1 Top and Bottom Cooling Clearance

Enclosure	A2-A5	B1-B4	C1, C3	C2, C4
a/b (inch [mm])	100	200	200	225

Table 2.1 Minimum Airflow Clearance Requirements

2.3.2 Lifting

- Check the weight of the unit to determine a safe lifting method
- Ensure that the lifting device is suitable for the task
- If necessary, plan for a hoist, crane, or forklift with the appropriate rating to move the unit
- For lifting, use hoist rings on the unit, where provided

2.3.3 Mounting

- Mount the unit vertically
- The adjustable frequency drive allows side by side installation
- Ensure that the strength of the mounting location will support the unit weight
- Mount the unit onto a solid flat surface or onto the optional backplate to provide cooling airflow (see Figure 2.2 and Figure 2.3)

- Improper mounting can result in overheating and reduced performance
- Use the slotted mounting holes on the unit for wall mounting, when provided.

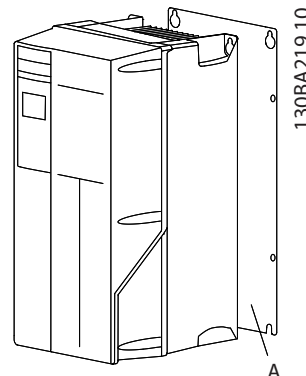

Figure 2.2 Proper Mounting with Backplate

Item A is a backplate properly installed for required airflow to cool the unit.

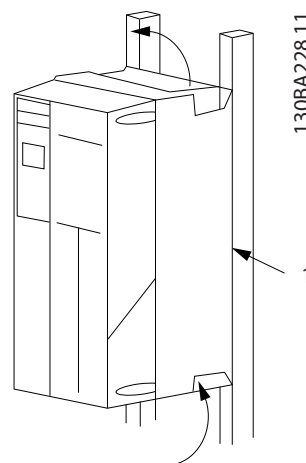

Figure 2.3 Proper Mounting with Railings

**NOTE!**

Backplate is needed when mounted on railings.

2.3.4 Tightening Torques

See 10.4 Connection Tightening Torques for proper tightening specifications.

## 2.4 Electrical Installation

This section contains detailed instructions for wiring the adjustable frequency drive. The following tasks are described.

- Wiring the motor to the adjustable frequency drive output terminals
- Wiring the AC line power to the adjustable frequency drive input terminals

- Connecting control and serial communication wiring
- After power has been applied, checking input and motor power; programming control terminals for their intended functions

Figure 2.4 shows a basic electrical connection.

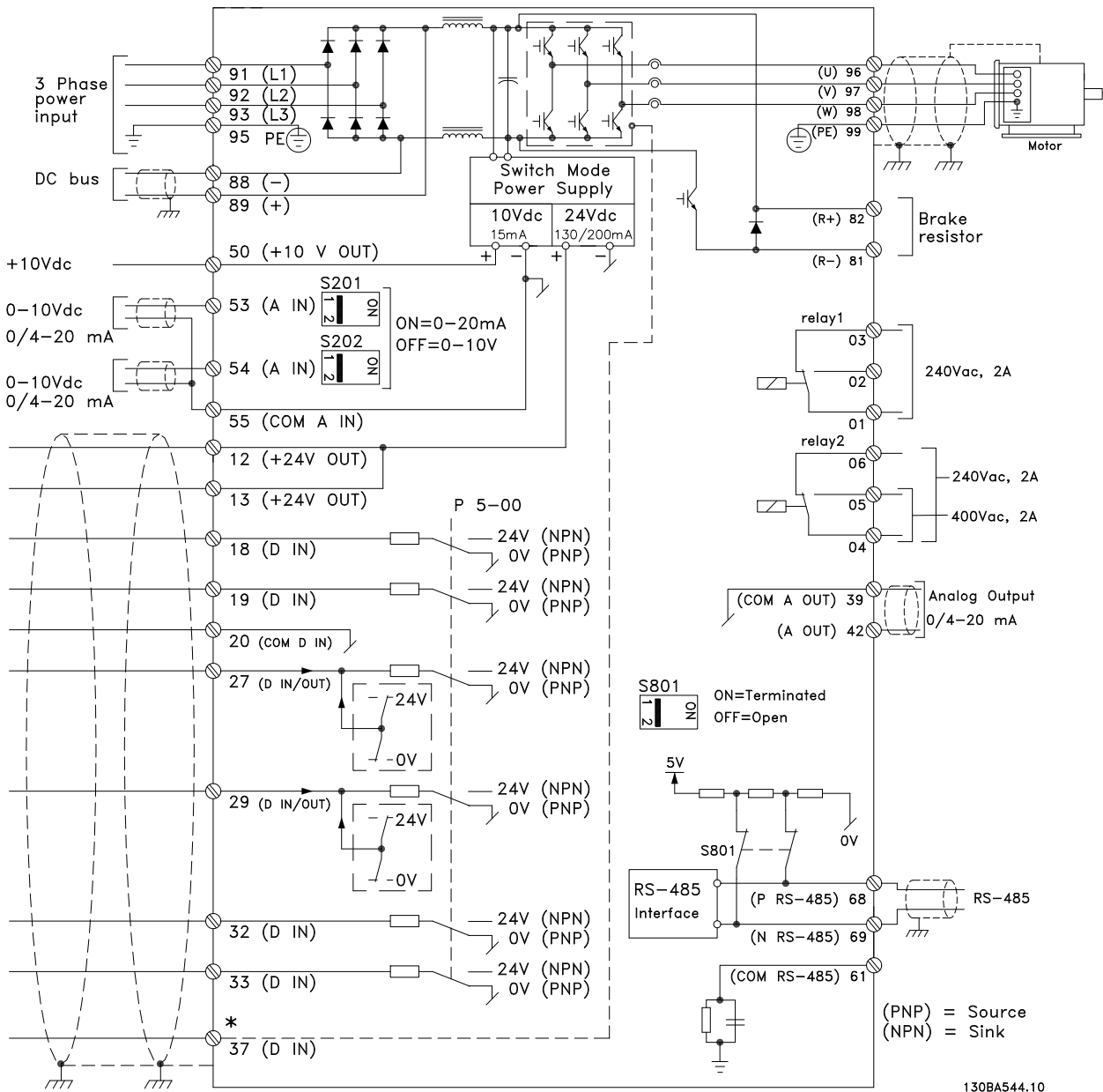

Figure 2.4 Basic Wiring Schematic Drawing.

\* Terminal 37 is an option

2

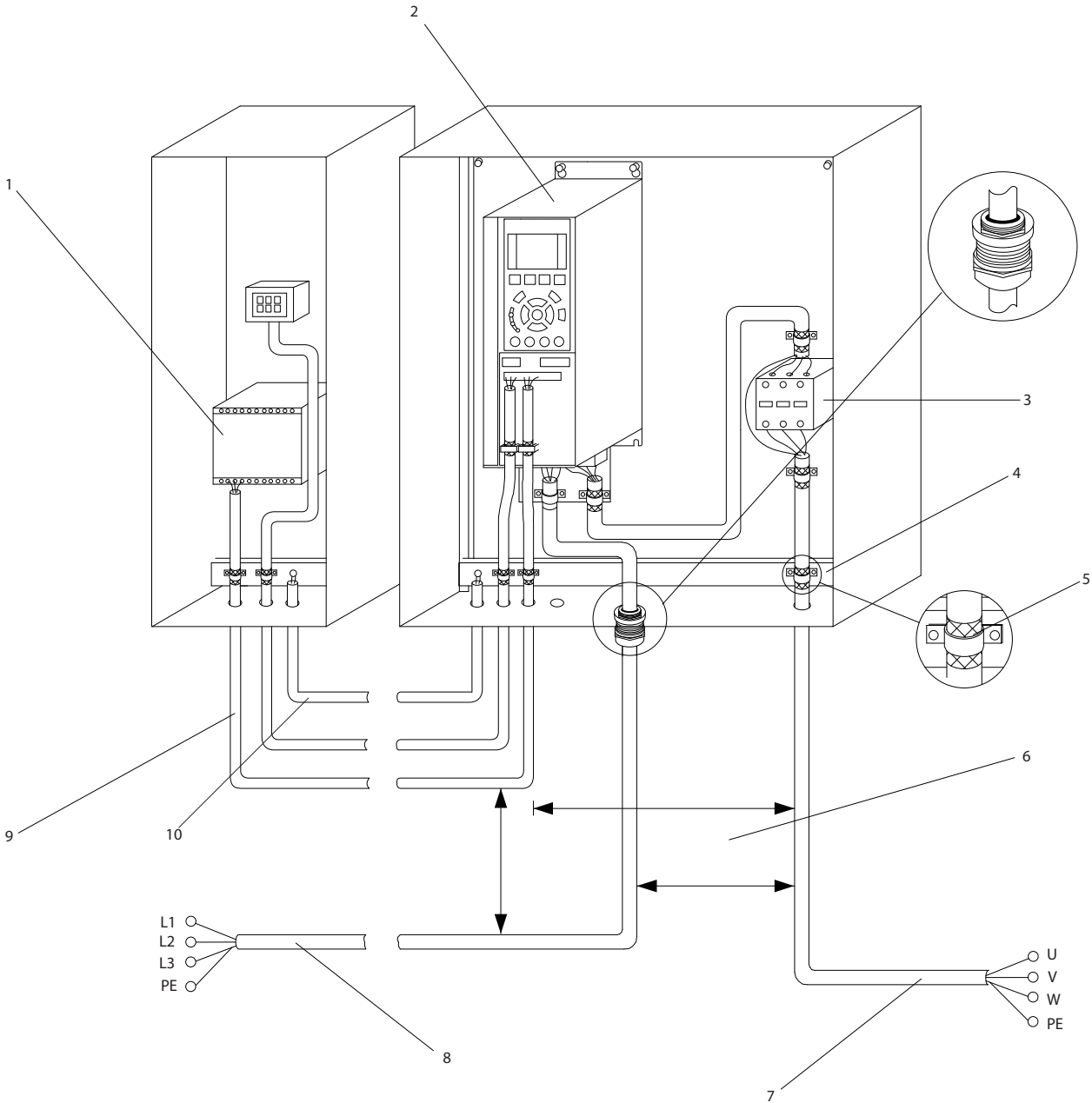

Figure 2.5 Typical Electrical Connection

1	PLC	6	Min. 7.9 in [200 mm] between control cables, motor and line power
2	Adjustable frequency drive	7	Motor, 3-phase and PE
3	Output contactor (generally not recommended)	8	Line power, 3-phase and reinforced PE
4	Grounding rail (PE)	9	Control wiring
5	Cable insulation (stripped)	10	Equalizing min. 0.025 in <sup>2</sup> [16 mm <sup>2</sup> ]

Table 2.2 Legend to Figure 2.5

### 2.4.1 Requirements

#### **⚠ WARNING**

##### **EQUIPMENT HAZARD!**

Rotating shafts and electrical equipment can be hazardous. All electrical work must conform to national and local electrical codes. It is strongly recommended that installation, start-up, and maintenance be performed only by trained and qualified personnel. Failure to follow these guidelines could result in death or serious injury.

#### **CAUTION**

##### **WIRING ISOLATION!**

Run input power, motor wiring and control wiring in three separate metallic conduits or use separated shielded cable for high frequency noise isolation. Failure to isolate power, motor and control wiring could result in less than optimum adjustable frequency drive and associated equipment performance.

For your safety, comply with the following requirements.

- Electronic controls equipment is connected to hazardous AC line voltage. Extreme care should be taken to protect against electrical hazards when applying power to the unit.
- Run motor cables from multiple adjustable frequency drives separately. Induced voltage from output motor cables run together can charge equipment capacitors even with the equipment turned off and locked out.

##### **Overload and Equipment Protection**

- An electronically activated function within the adjustable frequency drive provides overload protection for the motor. The overload calculates the level of increase to activate timing for the trip (controller output stop) function. The higher the current draw, the quicker the trip response. The overload provides Class 20 motor protection. See 8 *Warnings and Alarms* for details on the trip function.
- Because the motor wiring carries high frequency current, it is important that wiring for line power, motor power, and control is run separately. Use metallic conduit or separated shielded wire. Failure to isolate power, motor, and control wiring could result in less than optimum equipment performance.
- All adjustable frequency drives must be provided with short-circuit and overcurrent protection.

Input fusing is required to provide this protection, see *Figure 2.6*. If not factory supplied, fuses must be provided by the installer as part of installation. See maximum fuse ratings in *10.3 Fuse Specifications*.

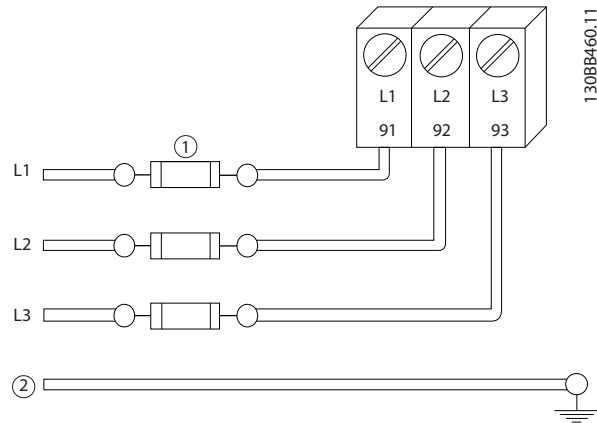

Figure 2.6 Fuses

##### **Wire Type and Ratings**

- All wiring must comply with local and national regulations regarding cross-section and ambient temperature requirements.
- Danfoss recommends that all power connections be made with a minimum 167 °F [75° C] rated copper wire.
- See *10.1 Power-dependent Specifications* for recommended wire sizes.

### 2.4.2 Grounding Requirements

#### **⚠ WARNING**

##### **GROUNDING HAZARD!**

For operator safety, it is important to ground the adjustable frequency drive properly in accordance with national and local electrical codes as well as instructions contained within this document. Ground currents are higher than 3.5 mA. Failure to ground the adjustable frequency drive properly could result in death or serious injury.

#### **NOTE!**

It is the responsibility of the user or certified electrical installer to ensure correct grounding of the equipment in accordance with national and local electrical codes and standards.

- Follow all local and national electrical codes to ground electrical equipment properly.
- Proper protective grounding for equipment with ground currents higher than 3.5 mA must be established, see 2.4.2.1 Leakage Current (>3.5 mA)
- A dedicated ground wire is required for input power, motor power and control wiring
- Use the clamps provided with the equipment for proper ground connections
- Do not ground one adjustable frequency drive to another in a “daisy chain” fashion
- Keep the ground wire connections as short as possible
- Using high-strand wire to reduce electrical noise is recommended
- Follow the motor manufacturer wiring requirements

### 2.4.2.1 Leakage Current (>3.5 mA)

Follow national and local codes regarding protective grounding of equipment with a leakage current > 3.5 mA. Adjustable frequency drive technology implies high frequency switching at high power. This will generate a leakage current in the ground connection. A fault current in the adjustable frequency drive at the output power terminals might contain a DC component which can charge the filter capacitors and cause a transient ground current. The ground leakage current depends on various system configurations including RFI filtering, shielded motor cables, and adjustable frequency drive power.

EN/IEC61800-5-1 (Power Drive System Product Standard) requires special care if the leakage current exceeds 3.5 mA. Grounding must be reinforced in one of the following ways:

- Ground wire of at least 0.0155 in<sup>2</sup> [10 mm<sup>2</sup>]
- Two separate ground wires both complying with the dimensioning rules

See EN 60364-5-54 § 543.7 for further information.

#### Using RCDs

Where residual current devices (RCDs), also known as ground leakage circuit breakers (GLCBs), are used, comply with the following:

- Use RCDs of type B only which are capable of detecting AC and DC currents
- Use RCDs with an inrush delay to prevent faults due to transient ground currents
- Dimension RCDs according to the system configuration and environmental considerations

### 2.4.2.2 Grounding Using Shielded Cable

Grounding clamps are provided for motor wiring (see Figure 2.7).

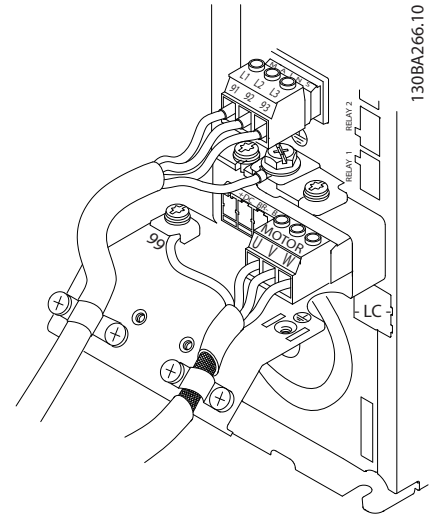

Figure 2.7 Grounding with Shielded Cable

### 2.4.3 Motor Connection

#### **WARNING**

#### **INDUCED VOLTAGE!**

Run output motor cables from multiple adjustable frequency drives separately. Induced voltage from output motor cables run together can charge equipment capacitors even with the equipment turned off and locked out. Failure to run output motor cables separately could result in death or serious injury.

- For maximum wire sizes, see 10.1 Power-dependent Specifications
- Comply with local and national electrical codes for cable sizes.
- Motor wiring knockouts or access panels are provided at the base of IP21 and higher (NEMA1/12) units
- Do not install power factor correction capacitors between the adjustable frequency drive and the motor
- Do not wire a starting or pole-changing device between the adjustable frequency drive and the motor.
- Connect the 3-phase motor wiring to terminals 96 (U), 97 (V), and 98 (W).

- Ground the cable in accordance with grounding instructions provided.
- Torque terminals in accordance with the information provided in 10.4.1 Connection Tightening Torques
- Follow the motor manufacturer wiring requirements

The three following figures represent line power input, motor, and ground for basic adjustable frequency drives. Actual configurations vary with unit types and optional equipment.

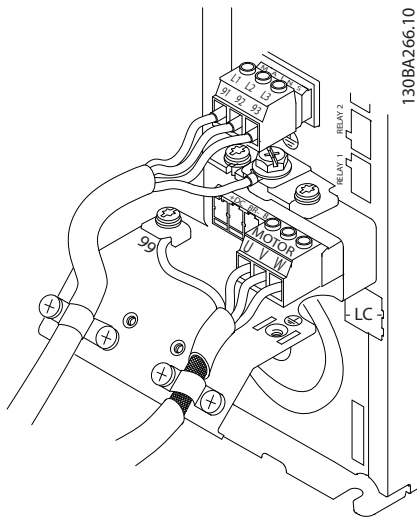

Figure 2.8 Motor, Line Power and Ground Wiring for A-Frame Sizes

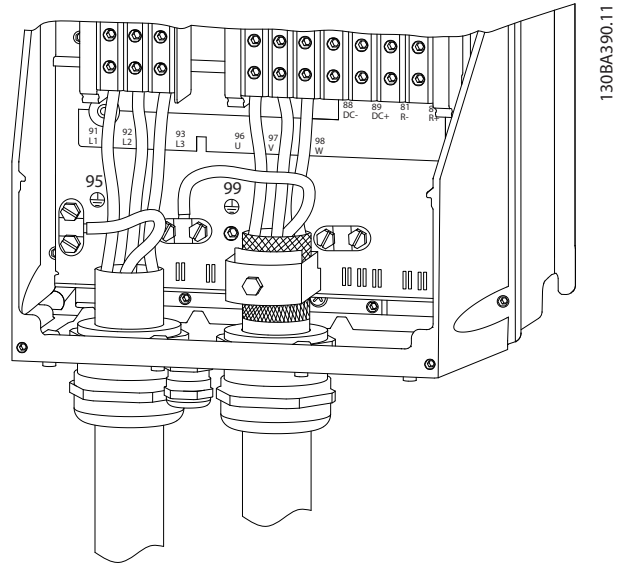

Figure 2.9 Motor, Line Power and Ground Wiring for B-Frame Sizes and Above Using Shielded Cable

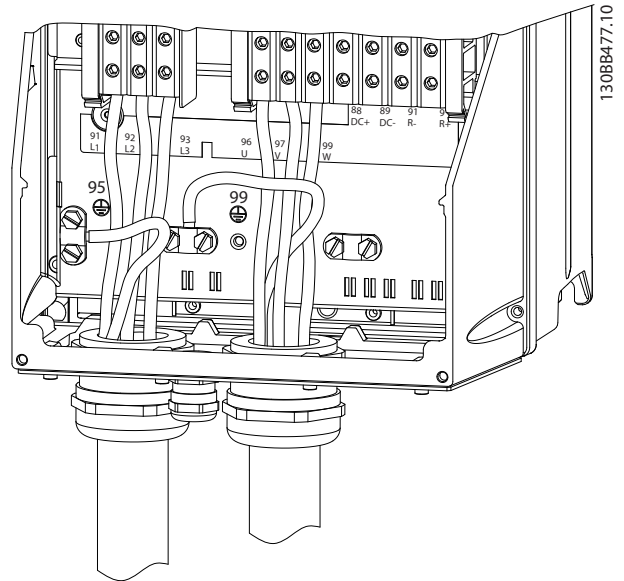

Figure 2.10 Motor, Line Power and Ground Wiring for B-Frame Sizes and Above Using Conduit

### 2.4.4 AC Line Input Connection

- Size wiring based upon the input current of the adjustable frequency drive. For maximum wire sizes, see *10.1 Power-dependent Specifications*.
- Comply with local and national electrical codes for cable sizes.
- Connect 3-phase AC input power wiring to terminals L1, L2, and L3 (see *Figure 2.11*).
- Depending on the configuration of the equipment, input power will be connected to the line power input terminals or the input disconnect.

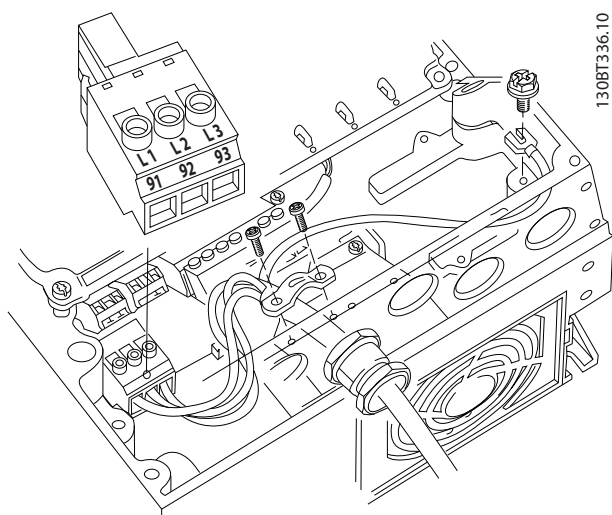

Figure 2.11 Connecting to AC Line Power

- Ground the cable in accordance with grounding instructions provided in *2.4.2 Grounding Requirements*
- All adjustable frequency drives may be used with an isolated input source as well as with ground reference power lines. When supplied from an isolated line power source (IT line power or floating delta) or TT/TN-S line power with a grounded leg (grounded delta), set *14-50 RFI 1* to OFF. When off, the internal RFI filter capacitors between the chassis and the intermediate circuit are isolated to avoid damage to the intermediate circuit and to reduce ground capacity currents in accordance with IEC 61800-3.

### 2.4.5 Control Wiring

- Isolate control wiring from high power components in the adjustable frequency drive.
- If the adjustable frequency drive is connected to a thermistor, for PELV isolation, optional thermistor control wiring must be reinforced/double insulated. A 24 V DC supply voltage is recommended.

#### 2.4.5.1 Access

- Remove access cover plate with a screw driver. See *Figure 2.12*.
- Or remove front cover by loosening attaching screws. See *Figure 2.13*.

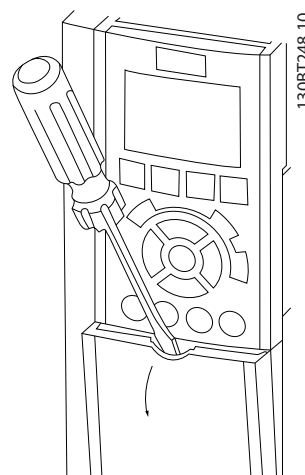

Figure 2.12 Control Wiring Access for A2, A3, B3, B4, C3 and C4 Enclosures



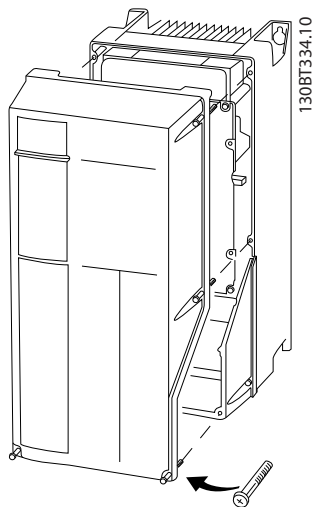

Figure 2.13 Control Wiring Access for A4, A5, B1, B2, C1 and C2 Enclosures

See Table 2.3 before tightening the covers.

Frame	IP20	IP21	IP55	IP66
A4/A5	-	-	1.5 [2]	1.5 [2]
B1	-	*	1.6 [2.2]	1.6 [2.2]
B2	-	*	1.6 [2.2]	1.6 [2.2]
C1	-	*	1.6 [2.2]	1.6 [2.2]
C2	-	*	1.6 [2.2]	1.6 [2.2]
* No screws to tighten				
- Does not exist				

Table 2.3 Tightening Torques for Covers (ft lb [Nm])

### 2.4.5.2 Control Terminal Types

Figure 2.17 shows the removable adjustable frequency drive connectors. Terminal functions and default settings are summarized in Table 2.4.

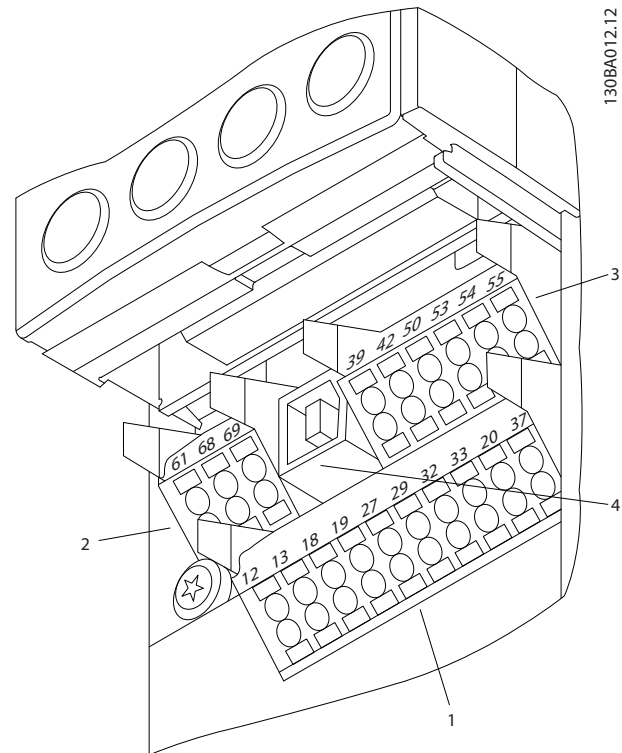

Figure 2.14 Control Terminal Locations

- **Connector 1** provides four programmable digital inputs terminals, two additional digital terminals programmable as either input or output, a 24 V DC terminal supply voltage, and a common for optional customer-supplied 24 V DC voltage
- **Connector 2** terminals (+)68 and (-)69 are for an RS-485 serial communications connection
- **Connector 3** provides two analog inputs, one analog output, 10 V DC supply voltage, and commons for the inputs and output
- **Connector 4** is a USB port available for use with the MCT 10 Set-up Software
- Also provided are two Form C relay outputs that are in various locations depending upon the adjustable frequency drive configuration and size
- Some options available for ordering with the unit may provide additional terminals. See the manual provided with the equipment option.

See 10.2 General Technical Data for terminal ratings details.

Terminal Description			
Digital Inputs/Outputs			
Terminal	Parameter	Default Setting	Description
12, 13	-	+24 V DC	24 V DC supply voltage. Maximum output current is 200 mA total for all 24 V loads. Usable for digital inputs and external transducers.
18	5-10	[8] Start	Digital inputs.
19	5-11	[0] No operation	
32	5-14	[0] No operation	
33	5-15	[0] No operation	
27	5-12	[2] Coast inverse	Selectable for either digital input or output. Default setting is input.
29	5-13	[14] JOG	
20	-		Common for digital inputs and 0 V potential for 24 V supply.
37	-	Safe Torque Off (STO)	(optional) Safe input. Used for STO.
Analog Inputs/Outputs			
39	-		Common for analog output
42	6-50	Speed 0 - High Limit	Programmable analog output. The analog signal is 0–20 mA or 4–20 mA at a maximum of 500Ω
50	-	+10 V DC	10 V DC analog supply voltage. 15 mA maximum commonly used for potentiometer or thermistor.
53	6-1	Reference	Analog input. Selectable for voltage or current. Switches A53 and A54 select mA or V.
54	6-2	Feedback	
55	-		Common for analog input
Serial Communication			

Terminal Description			
Digital Inputs/Outputs			
Terminal	Parameter	Default Setting	Description
61	-		Integrated RC filter for cable screen. ONLY for connecting the shield when experiencing EMC problems.
68 (+)	8-3		RS-485 Interface. A control card switch is provided for termination resistance.
69 (-)	8-3		
Relays			
01, 02, 03	5-40 [0]	[0] Alarm	Form C relay output. Usable for AC or DC voltage and resistive or inductive loads.
04, 05, 06	5-40 [1]	[0] Running	

Table 2.4 Terminal Description

### 2.4.5.3 Wiring to Control Terminals

Control terminal connectors can be unplugged from the adjustable frequency drive for ease of installation, as shown in Figure 2.15.

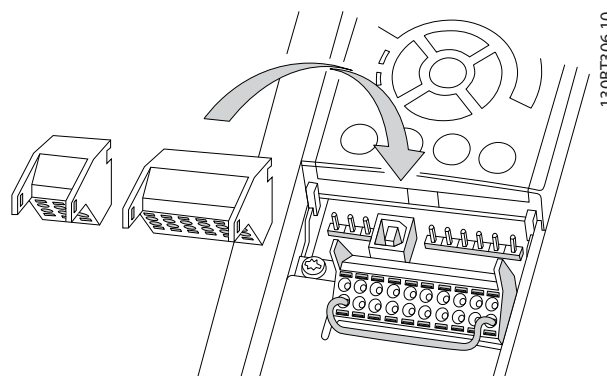

Figure 2.15 Unplugging Control Terminals

1. Open the contact by inserting a small screwdriver into the slot above or below the contact, as shown in Figure 2.16.
2. Insert the bared control wire into the contact.
3. Remove the screwdriver to fasten the control wire into the contact.
4. Ensure the contact is firmly established and not loose. Loose control wiring can be the source of equipment faults or less than optimal operation.

See 10.1 Power-dependent Specifications for control terminal wiring sizes.

See 6 Application Set-up Examples for typical control wiring connections.

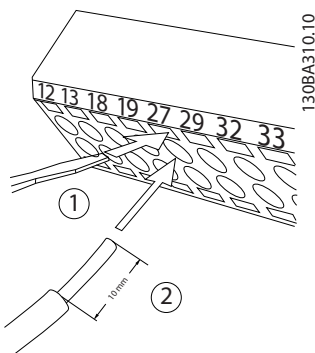

Figure 2.16 Connecting Control Wiring

### 2.4.5.4 Using Shielded Control Cables

#### Correct shielding

The preferred method in most cases is to secure control and serial communication cables with shielding clamps provided at both ends to ensure best possible high frequency cable contact.

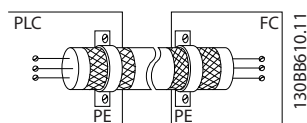

Figure 2.17 Shielding Clamps at Both Ends

#### 50/60 Hz ground loops

With very long control cables, ground loops may occur. To eliminate ground loops, connect one end of the shield-to-ground with a 100 nF capacitor (keeping leads short).

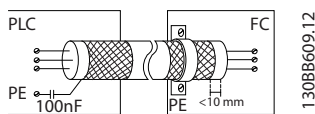

Figure 2.18 Connection with a 100 nF Capacitor

#### Avoid EMC noise on serial communication

To eliminate low-frequency noise between adjustable frequency drives, connect one end of the shield to terminal 61. This terminal is connected to ground via an internal RC link. Use twisted-pair cables to reduce interference between conductors.

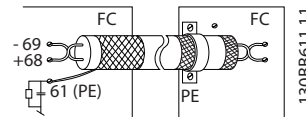

Figure 2.19 Twisted-pair Cables

### 2.4.5.5 Control Terminal Functions

Adjustable frequency drive functions are commanded by receiving control input signals.

- Each terminal must be programmed for the function it will be supporting in the parameters associated with that terminal. See Table 2.4 for terminals and associated parameters.
- It is important to confirm that the control terminal is programmed for the correct function. See 4 User Interface for details on accessing parameters and 5 About Adjustable Frequency Drive Programming for details on programming.
- The default terminal programming is intended to initiate adjustable frequency drive functioning in a typical operational mode.

### 2.4.5.6 Jumper Terminals 12 and 27

A jumper wire may be required between terminal 12 (or 13) and terminal 27 for the adjustable frequency drive to operate when using factory default programming values.

- Digital input terminal 27 is designed to receive a 24 V DC external interlock command. In many applications, the user wires an external interlock device to terminal 27
- When no interlock device is used, wire a jumper between control terminal 12 (recommended) or 13 to terminal 27. This provides an internal 24 V signal on terminal 27.
- No signal present prevents the unit from operating.
- When the status line at the bottom of the LCP reads AUTO REMOTE COASTING or Alarm 60 External Interlock is displayed, this indicates that the unit is ready to operate but is missing an input signal on terminal 27.

- When factory installed optional equipment is wired to terminal 27, do not remove that wiring.

### 2.4.5.7 Terminal 53 and 54 Switches

- Analog input terminals 53 and 54 can select either voltage (0 to 10 V) or current (0/4–20 mA) input signals
- Remove power to the adjustable frequency drive before changing switch positions.
- Set switches A53 and A54 to select the signal type. U selects voltage, I selects current.
- The switches are accessible when the LCP has been removed (see *Figure 2.20*). Note that some option cards available for the unit may cover these switches and must be removed to change switch settings. Always remove power to the unit before removing option cards.
- Terminal 53 default is for a speed reference signal in open-loop set in *16-61 Terminal 53 Switch Setting*
- Terminal 54 default is for a feedback signal in closed-loop set in *16-63 Terminal 54 Switch Setting*

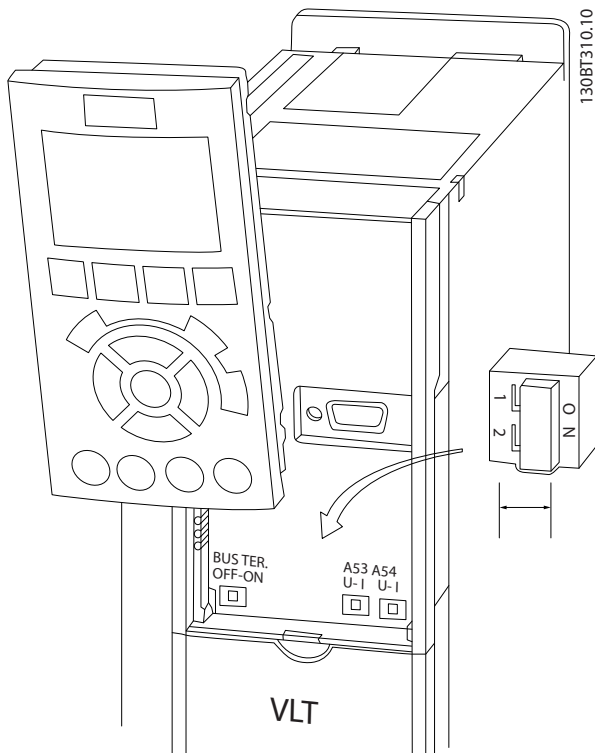

Figure 2.20 Location of Terminals 53 and 54 Switches

### 2.4.5.8 Mechanical Brake Control

In hoisting/lowering applications, it is necessary to be able to control an electro-mechanical brake:

- Control the brake using any relay output or digital output (terminal 27 or 29).
- Keep the output closed (voltage-free) as long as the adjustable frequency drive is unable to ‘support’ the motor, such as when the load is too heavy, for example.
- Select [32] *Mechanical brake control* in parameter group *5-4\* Relays* for applications with an electro-mechanical brake.
- The brake is released when the motor current exceeds the preset value in *2-20 Release Brake Current*.
- The brake is engaged when the output frequency is less than the frequency set in *2-21 Activate Brake Speed [RPM]* or *2-22 Activate Brake Speed [Hz]*, and only if the adjustable frequency drive carries out a stop command.

If the adjustable frequency drive is in alarm mode or in an overvoltage situation, the mechanical brake immediately cuts in.

In the vertical movement, the key point is that the load must be held, stopped, controlled (raised, lowered) in a safe mode during the entire operation. Because the adjustable frequency drive is not a safety device, the crane/lift designer (OEM) must decide on the type and number of safety devices (e.g., speed switch, emergency brakes, etc.) to be used, in order to be able to stop the load in case of emergency or malfunction of the system, according to relevant national crane/lift regulations.

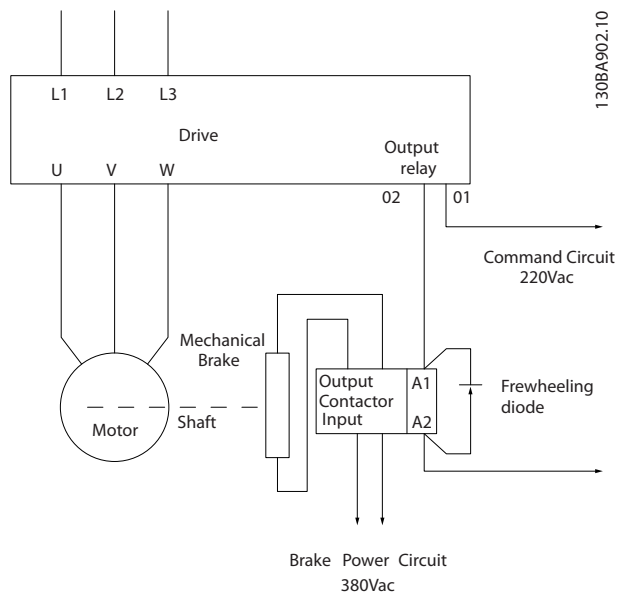

130BA902.10

Figure 2.21 Connecting the Mechanical Brake to the Adjustable Frequency Drive

## 2.4.6 Serial Communication

Connect RS-485 serial communication wiring to terminals (+)68 and (-)69.

- A shielded serial communication cable is recommended
- See 2.4.2 *Grounding Requirements* for proper grounding

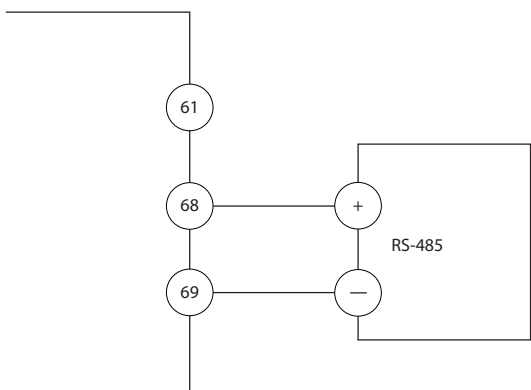

130BB489.10

Figure 2.22 Serial Communication Wiring Diagram

For basic serial communication set-up, select the following

1. Protocol type in 8-30 *Protocol*.
  2. Adjustable frequency drive address in 8-31 *Address*.
  3. Baud rate in 8-32 *Baud Rate*.
- Four communication protocols are internal to the adjustable frequency drive. Follow the motor manufacturer wiring requirements.
    - Danfoss FC
    - Modbus RTU
    - Johnson Controls N2®
  - Functions can be programmed remotely using the protocol software and RS-485 connection or in parameter group 8-\*\* *Communications and Options*.
  - Selecting a specific communication protocol changes various default parameter settings to match that protocol's specifications along with making additional protocol-specific parameters available
  - Option cards for the adjustable frequency drive are available to provide additional communication protocols. See the option-card documentation for installation and instruction manual



## 3 Start-up and Functional Testing

### 3.1 Pre-start

#### 3.1.1 Safety Inspection

#### **⚠ WARNING**

##### **HIGH VOLTAGE!**

If input and output connections have been connected improperly, there is potential for high voltage on these terminals. If power leads for multiple motors are improperly run in same conduit, there is potential for leakage current to charge capacitors within the adjustable frequency drive, even when disconnected from line power input. For initial start-up, make no assumptions about power components. Follow pre-start procedures. Failure to follow pre-start procedures could result in personal injury or damage to equipment.

1. Input power to the unit must be OFF and locked out. Do not rely on the adjustable frequency drive disconnect switches for input power isolation.
2. Verify that there is no voltage on input terminals L1 (91), L2 (92), and L3 (93), phase-to-phase and phase-to-ground,
3. Verify that there is no voltage on output terminals 96 (U), 97 (V), and 98 (W), phase-to-phase and phase-to-ground.
4. Confirm continuity of the motor by measuring ohm values on U-V (96-97), V-W (97-98), and W-U (98-96).
5. Check for proper grounding of the adjustable frequency drive as well as the motor.
6. Inspect the adjustable frequency drive for loose connections on terminals.
7. Record the following motor nameplate data: power, voltage, frequency, full load current, and nominal speed. These values are needed to program motor nameplate data later.
8. Confirm that the supply voltage matches voltage of adjustable frequency drive and motor.

## CAUTION

Before applying power to the unit, inspect the entire installation as detailed in *Table 3.1*. Check mark those items when completed.

3

Inspect for	Description	<input checked="" type="checkbox"/>
Auxiliary equipment	<ul style="list-style-type: none"> <li>Look for auxiliary equipment, switches, disconnects, or input fuses/circuit breakers that may reside on the input power side of the adjustable frequency drive or output side to the motor. Ensure that they are ready for full speed operation.</li> <li>Check function and installation of any sensors used for feedback to the adjustable frequency drive.</li> <li>Remove power factor correction caps on motor(s), if present.</li> </ul>	
Cable routing	<ul style="list-style-type: none"> <li>Ensure that input power, motor wiring and control wiring are separated or in three separate metallic conduits for high frequency noise isolation.</li> </ul>	
Control wiring	<ul style="list-style-type: none"> <li>Check for broken or damaged wires and loose connections.</li> <li>Check that control wiring is isolated from power and motor wiring for noise immunity.</li> <li>Check the voltage source of the signals, if necessary.</li> <li>The use of shielded cable or twisted pair is recommended. Ensure that the shield is terminated correctly.</li> </ul>	
Cooling clearance	<ul style="list-style-type: none"> <li>Make sure that the top and bottom clearance is adequate to ensure proper airflow for cooling.</li> </ul>	
EMC considerations	<ul style="list-style-type: none"> <li>Check for proper installation regarding electromagnetic compatibility.</li> </ul>	
Environmental considerations	<ul style="list-style-type: none"> <li>See equipment label for the maximum ambient operating temperature limits.</li> <li>Humidity levels must be 5–95% non-condensing.</li> </ul>	
Fusing and circuit breakers	<ul style="list-style-type: none"> <li>Check for proper fusing or circuit breakers.</li> <li>Check that all fuses are inserted firmly and in operational condition and that all circuit breakers are in the open position.</li> </ul>	
Grounding	<ul style="list-style-type: none"> <li>The unit requires a ground wire from its chassis to the building ground.</li> <li>Check for good ground connections that are tight and free of oxidation.</li> <li>Grounding to conduit or mounting the back panel to a metal surface is not a suitable ground.</li> </ul>	
Input and output power wiring	<ul style="list-style-type: none"> <li>Check for loose connections.</li> <li>Check that motor and line power are in separate conduit or separated shielded cables.</li> </ul>	
Panel interior	<ul style="list-style-type: none"> <li>Make sure that the unit interior is free of dirt, metal chips, moisture, and corrosion.</li> </ul>	
Switches	<ul style="list-style-type: none"> <li>Ensure that all switch and disconnect settings are in the proper positions.</li> </ul>	
Vibration	<ul style="list-style-type: none"> <li>Check that the unit is mounted solidly or that shock mounts are used, as necessary.</li> <li>Check for an unusual amount of vibration.</li> </ul>	

**Table 3.1 Start-up Check List**



### 3.2 Applying Power to the Adjustable Frequency Drive

#### **⚠ WARNING**

##### HIGH VOLTAGE!

Adjustable frequency drives contain high voltage when connected to AC line power. Installation, start-up and maintenance should be performed by qualified personnel only. Failure to comply could result in death or serious injury.

#### **⚠ WARNING**

##### UNINTENDED START!

When the adjustable frequency drive is connected to AC line power, the motor may start at any time. The adjustable frequency drive, motor, and any driven equipment must be in operational readiness. Failure to comply could result in death, serious injury, equipment, or property damage.

1. Confirm that the input voltage is balanced within 3%. If not, correct input voltage imbalance before proceeding. Repeat this procedure after the voltage correction.
2. Ensure that optional equipment wiring, if present, matches the installation application.
3. Ensure that all operator devices are in the OFF position. Panel doors should be closed or cover mounted.
4. Apply power to the unit. DO NOT start the adjustable frequency drive at this time. For units with a disconnect switch, turn to the ON position to apply power to the adjustable frequency drive.

#### NOTE!

If the status line at the bottom of the LCP reads **AUTO REMOTE COASTING** or **Alarm 60 External Interlock** is displayed, this indicates that the unit is ready to operate but is missing an input signal on terminal 27. See *Figure 1.4* for details.

### 3.3 Basic Operational Programming

#### 3.3.1 Required Initial Adjustable Frequency Drive Programming

Adjustable frequency drives require basic operational programming before running for best performance. Basic operational programming requires entering motor nameplate data for the motor being operated and the minimum and maximum motor speeds. Enter data in accordance with the following procedure. The recommended parameter settings are intended for start-up and checkout purposes. Application settings may vary. See *4 User Interface* for detailed instructions on entering data through the LCP.

Enter data with power ON, but before operating the adjustable frequency drive.

1. Press [Main Menu] twice on the LCP.
2. Use the navigation keys to scroll to parameter group 0-\*\* Operation/Display and press [OK].

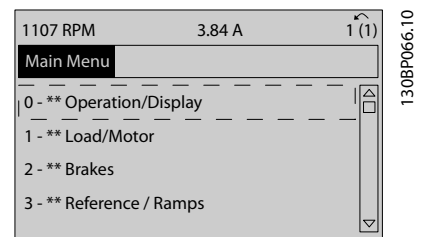

Figure 3.1 Main Menu

3. Use navigation keys to scroll to parameter group 0-0\* Basic Settings and press [OK].

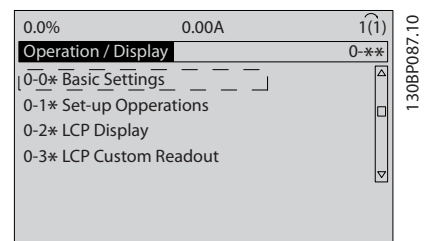

Figure 3.2 Operation/Display

4. Use navigation keys to scroll to *0-03 Regional Settings* and press [OK].

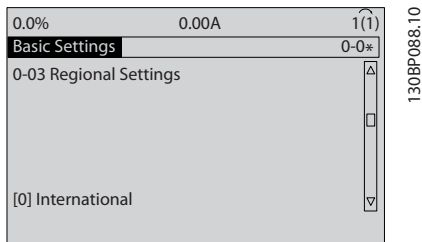

Figure 3.3 Basic Settings

5. Use navigation keys to select *[0] International* or *[1] North America* as appropriate and press [OK]. (This changes the default settings for a number of basic parameters. See 5.4 *International/North American Default Parameter Settings* for a complete list.)
6. Press [Quick Menu] on the LCP.
7. Use the navigation keys to scroll to parameter group *Q2 Quick Set-up* and press [OK].

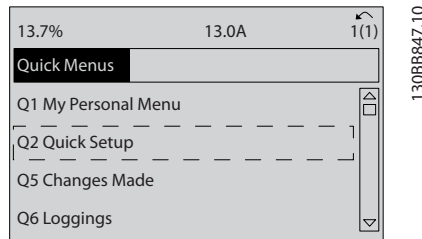

Figure 3.4 Quick Menu

8. Select language and press [OK].
9. A jumper wire should be in place between control terminals 12 and 27. If this is the case, leave *5-12 Terminal 27 Digital Input* at factory default. Otherwise select *No Operation*. For adjustable frequency drives with an optional Danfoss bypass, no jumper wire is required.
10. *3-02 Minimum Reference*
11. *3-03 Maximum Reference*
12. *3-41 Ramp 1 Ramp-up Time*
13. *3-42 Ramp 1 Ramp-down Time*
14. *3-13 Reference Site*. Linked to *Hand/Auto\* Local Remote*.

### 3.4 PM Motor Set-up in VVCplus

## CAUTION

Use only a PM motor with fans and pumps.

#### Initial Programming Steps

1. Activate PM motor operation *1-10 Motor Construction*, select *[1] PM, non-salient SPM*
2. Make sure to set *0-02 Motor Speed Unit* to *[0] RPM*

#### Programming motor data.

After selecting PM motor in *1-10 Motor Construction*, the PM motor-related parameters in parameter groups 1-2\*, 1-3\* and 1-4\* are active.

The information can be found on the motor nameplate and in the motor data sheet.

Following parameters must be programmed in the listed order

1. *1-24 Motor Current*
2. *1-26 Motor Cont. Rated Torque*
3. *1-25 Motor Nominal Speed*
4. *1-39 Motor Poles*
5. *1-30 Stator Resistance (Rs)*

Enter line to common stator winding resistance (Rs). If only line-line data are available, divide the line-line value by 2 to achieve the line to common (starpoint) value.

It is also possible to measure the value with an ohmmeter, which will also take the resistance of the cable into account. Divide the measured value by 2 and enter the result.

6. *1-37 d-axis Inductance (Ld)*

Enter line to common direct axis inductance of the PM motor. If only line-line data are available, divide the line-line value by 2 to achieve the line-common (starpoint) value.

It is also possible to measure the value with an inductance meter, which will also take the inductance of the cable into account. Divide the measured value by 2 and enter the result.

7. *1-40 Back EMF at 1000 RPM*

Enter line-to-line back EMF of PM Motor at 1,000 RPM mechanical speed (RMS value). Back EMF is the voltage generated by a PM motor when no drive is connected and the shaft is turned externally. Back EMF is normally specified for nominal motor speed or for 1000 RPM measured between two lines. If the value is not available for a motor speed of 1000 RPM, calculate the correct

value as follows: If back EMF is, e.g., 320 V at 1800 RPM, it can be calculated at 1000 RPM as follows: Back EMF= (Voltage / RPM)\*1000 = (320/1800)\*1000 = 178. This is the value that must be programmed for *1-40 Back EMF at 1000 RPM*

**Test Motor Operation**

1. Start the motor at low speed (100 to 200 RPM). If the motor does not turn, check installation, general programming and motor data.
2. Check if start function in *1-70 PM Start Mode* fits the application requirements.

**Rotor detection**

This function is the recommended choice for applications where the motor starts from standstill, e.g., pumps or conveyors. On some motors, an acoustic sound is heard when the impulse is sent out. This does not harm the motor.

**Parking**

This function is the recommended choice for applications where the motor is rotating at slow speed, e.g., windmilling in fan applications. *2-06 Parking Current* and *2-07 Parking Time* can be adjusted. Increase the factory setting of these parameters for applications with high inertia.

Start the motor at nominal speed. In case the application does not run well, check the VVC<sup>plus</sup> PM settings. Recommendations for different applications can be seen in *Table 3.2*.

Application	Settings
Low inertia applications $I_{Load}/I_{Motor} < 5$	<i>1-17 Voltage filter time const.</i> to be increased by factor 5 to 10 <i>1-14 Damping Gain</i> should be reduced <i>1-66 Min. Current at Low Speed</i> should be reduced (<100%)
Low inertia applications $50 > I_{Load}/I_{Motor} > 5$	Keep calculated values
High inertia applications $I_{Load}/I_{Motor} > 50$	<i>1-14 Damping Gain</i> , <i>1-15 Low Speed Filter Time Const.</i> and <i>1-16 High Speed Filter Time Const.</i> should be increased
High load at low speed <30% (rated speed)	<i>1-17 Voltage filter time const.</i> should be increased <i>1-66 Min. Current at Low Speed</i> should be increased (>100% for longer time can overheat the motor)

**Table 3.2 Recommendations for Different Applications**

If the motor starts oscillating at a certain speed, increase *1-14 Damping Gain*. Increase the value in small steps. Depending on the motor, a good value for this parameter can be 10% or 100% higher than the default value.

Starting torque can be adjusted in *1-66 Min. Current at Low Speed*. 100% provides nominal torque as starting torque.

**3.5 Automatic Motor Adaptation**

Automatic motor adaptation (AMA) is a test procedure that measures the electrical characteristics of the motor to optimize compatibility between the adjustable frequency drive and the motor.

- The adjustable frequency drive builds a mathematical model of the motor for regulating output motor current. The procedure also tests the input phase balance of electrical power. It compares the motor characteristics with the data entered in parameters 1-20 to 1-25.
- It does not cause the motor to run or harm to the motor
- Some motors may be unable to run the complete version of the test. In that case, select [2] *Enable reduced AMA*
- If an output filter is connected to the motor, select *Enable reduced AMA*
- If warnings or alarms occur, see *8 Warnings and Alarms*
- Run this procedure on a cold motor for best results

**NOTE!**

The AMA algorithm does not work when using PM motors.

**To run AMA**

1. Press [Main Menu] to access parameters.
2. Scroll to parameter group *1-\*\* Load and Motor*.
3. Press [OK].
4. Scroll to parameter group *1-2\* Motor Data*.
5. Press [OK].
6. Scroll to *1-29 Automatic Motor Adaptation (AMA)*.
7. Press [OK].
8. Select [1] *Enable complete AMA*.
9. Press [OK].
10. Follow on-screen instructions.

11. The test will run automatically and indicate when it is complete.

### 3.6 Check Motor Rotation

Before running the adjustable frequency drive, check the motor rotation. The motor will run briefly at 5 Hz or the minimum frequency set in *4-12 Motor Speed Low Limit [Hz]*.

1. Press [Main Menu].
2. Press [OK].
3. Navigate to *1-28 Motor Rotation Check*.
4. Press [OK].
5. Scroll to *[1] Enable*.

The following text will appear: *Note! Motor may run in wrong direction.*

6. Press [OK].
7. Follow the on-screen instructions.

To change the direction of rotation, remove power to the adjustable frequency drive and wait for power to discharge. Reverse the connection of any two of the three motor cables on the motor or adjustable frequency drive side of the connection.

### 3.7 Local Control Test

#### **CAUTION**

##### **MOTOR START!**

Ensure that the motor, system and any attached equipment are ready for start. It is the responsibility of the user to ensure safe operation under any condition. Failure to ensure that the motor, system, and any attached equipment are ready for start could result in personal injury or equipment damage.

##### **NOTE!**

The [Hand On] key provides a local start command to the adjustable frequency drive. The [Off] key provides the stop function.

When operating in local mode, [▲] and [▼] increase and decrease the speed output of the adjustable frequency drive. [◀] and [▶] move the display cursor in the numeric display.

1. Press [Hand On].
2. Accelerate the adjustable frequency drive by pressing [▲] to full speed. Moving the cursor left of the decimal point provides quicker input changes.
3. Note any acceleration problems.
4. Press [Off].
5. Note any deceleration problems.

If acceleration problems were encountered

- If warnings or alarms occur, see *8 Warnings and Alarms*.
- Check that motor data is entered correctly.
- Increase the ramp-up time accel time in *3-41 Ramp 1 Ramp-up Time*.
- Increase current limit in *4-18 Current Limit*.
- Increase torque limit in *4-16 Torque Limit Motor Mode*.

If deceleration problems were encountered

- If warnings or alarms occur, see *8 Warnings and Alarms*.
- Check that motor data is entered correctly.
- Increase the ramp-down time decel time in *3-42 Ramp 1 Ramp-down Time*.
- Enable overvoltage control in *2-17 Over-voltage Control*.

See *4.1.1 Local Control Panel* for resetting the adjustable frequency drive after a trip.

##### **NOTE!**

*3.2 Applying Power to the Adjustable Frequency Drive* to *3.3 Basic Operational Programming* conclude the procedures for applying power to the adjustable frequency drive, basic programming, set-up and functional testing.

### 3.8 System Start-up

The procedure in this section requires user-wiring and application programming to be completed. *6 Application Set-up Examples* is intended to help with this task. Other aids to application set-up are listed in *1.2 Additional Resources*. The following procedure is recommended after application set-up by the user is completed.

#### **CAUTION**

##### **MOTOR START!**

**Ensure that the motor, system and any attached equipment is ready for start. It is the responsibility of the user to ensure safe operation under any condition. Failure to do so could result in personal injury or equipment damage.**

1. Press [Auto On].
2. Ensure that external control functions are properly wired to the adjustable frequency drive and all programming completed.
3. Apply an external run command.
4. Adjust the speed reference throughout the speed range.
5. Remove the external run command.
6. Note any problems.

If warnings or alarms occur, see *8 Warnings and Alarms*.

### 3.9 Acoustic Noise or Vibration

If the motor or the equipment driven by the motor, e.g., a fan blade, is making noise or vibrations at certain frequencies, try the following:

- Speed Bypass, parameter group 4-6\*
- Overmodulation, *14-03 Overmodulation* set to off
- Switching pattern and switching frequency parameter group 14-0\*
- Resonance Dampening, *1-64 Resonance Dampening*



## 4 User Interface

### 4.1 Local Control Panel

The local control panel (LCP) is the combined display and keypad on the front of the unit. The LCP is the user interface to the adjustable frequency drive.

The LCP has several user functions.

- Start, stop, and control speed when in local control
- Display operational data, status, warnings and cautions
- Programming adjustable frequency drive functions
- Manually reset the adjustable frequency drive after a fault when auto-reset is inactive

An optional numeric LCP (NLCP) is also available. The NLCP operates in a manner similar to the LCP. See the *Programming Guide* for details on use of the NLCP.

#### 4.1.1 LCP Layout

The LCP is divided into four functional groups (see *Figure 4.1*).

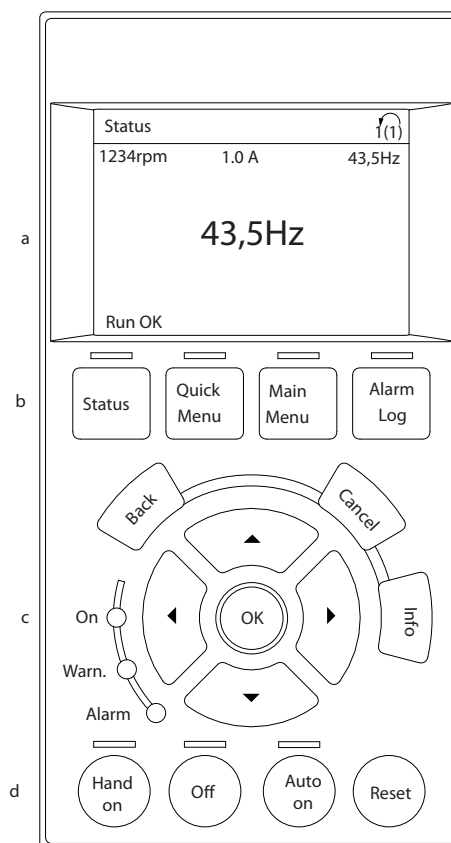

130BC362.10

Figure 4.1 LCP

- Display area.
- Display menu keys for changing the display to show status options, programming, or error message history.
- Navigation keys for programming functions, moving the display cursor, and speed control in local operation. Also included are the status indicator lights.
- Operational mode keys and reset.

### 4.1.2 Setting LCP Display Values

The display area is activated when the adjustable frequency drive receives power from AC line voltage, a DC bus terminal, or an external 24 V DC supply.

The information displayed on the LCP can be customized for user application.

- Each display readout has a parameter associated with it
- Options are selected in the quick menu Q3-13 *Display Settings*
- Display 2 has an alternate larger display option
- The adjustable frequency drive status at the bottom line of the display is generated automatically and is not selectable

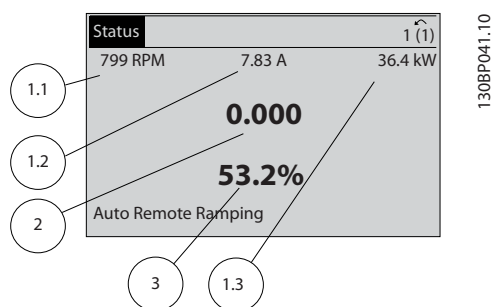

Figure 4.2 Display Readouts

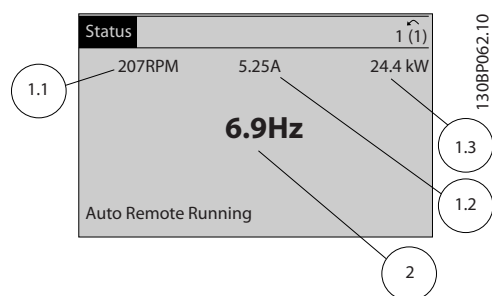

Figure 4.3 Display Readouts

Display	Parameter number	Default setting
1.1	0-20	Motor RPMs
1.2	0-21	Motor current
1.3	0-22	Motor power (kW)
2	0-23	Motor frequency
3	0-24	Reference in percent

Table 4.1 Legend to Figure 4.2 and Figure 4.3

### 4.1.3 Display Menu Keys

Menu keys are used for menu access for parameter set-up, toggling through status display modes during normal operation, and viewing fault log data.



Figure 4.4 Menu Keys

Key	Function
<b>Status</b>	Shows operational information. <ul style="list-style-type: none"> <li>• In Auto mode, press to toggle between status readout displays.</li> <li>• Press repeatedly to scroll through each status display.</li> <li>• Press [Status] plus [▲] or [▼] to adjust the display brightness.</li> <li>• The symbol in the upper right corner of the display shows the direction of motor rotation and which set-up is active. This is not programmable.</li> </ul>
<b>Quick Menu</b>	Allows access to programming parameters for initial set-up instructions and many detailed application instructions. <ul style="list-style-type: none"> <li>• Press to access Q2 Quick Set-up for sequenced instructions to program the basic adjustable frequency drive set-up</li> <li>• Follow the sequence of parameters as presented for the function set-up</li> </ul>
<b>Main Menu</b>	Allows access to all programming parameters. <ul style="list-style-type: none"> <li>• Press twice to access top-level index</li> <li>• Press once to return to the last location accessed.</li> <li>• Press to enter a parameter number for direct access to that parameter.</li> </ul>
<b>Alarm Log</b>	Displays a list of current warnings, the last ten alarms, and the maintenance log. <ul style="list-style-type: none"> <li>• For details about the adjustable frequency drive before it entered the alarm mode, select the alarm number using the navigation keys and press [OK].</li> </ul>

Table 4.2 Function Description Menu Keys



### 4.1.4 Navigation Keys

Navigation keys are used for programming functions and moving the display cursor. The navigation keys also provide speed control in local (hand) operation. Three adjustable frequency drive status indicators are also located in this area.

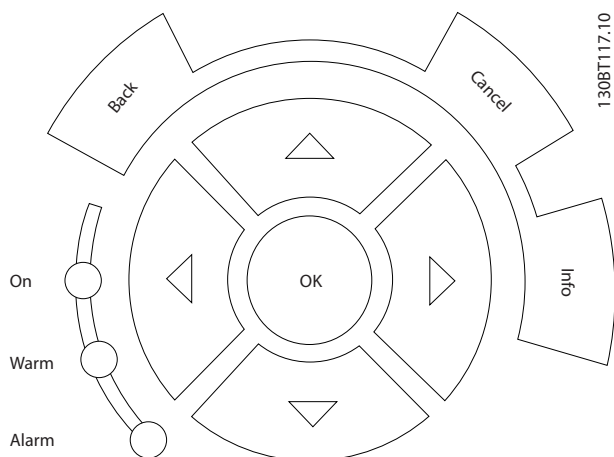

Figure 4.5 Navigation Keys

Key	Function
<b>Back</b>	Reverts to the previous step or list in the menu structure.
<b>Cancel</b>	Cancels the last change or command as long as the display mode has not changed.
<b>Info</b>	Press for a definition of the function being displayed.
<b>Navigation Keys</b>	Use the four navigation keys to move between items in the menu.
<b>OK</b>	Use to access parameter groups or to enable a choice.

Table 4.3 Navigation Keys Functions

Light	Indicator	Function
Green	ON	The ON light activates when the adjustable frequency drive receives power from AC line voltage, a DC bus terminal, or an external 24 V supply.
Yellow	WARNING	When warning conditions are met, the yellow WARNING light comes on and text appears in the display area identifying the problem.
Red	ALARM	A fault condition causes the red alarm light to flash and an alarm text is displayed.

Table 4.4 Indicator Lights Functions

### 4.1.5 Operation Keys

Operation keys are found at the bottom of the LCP.

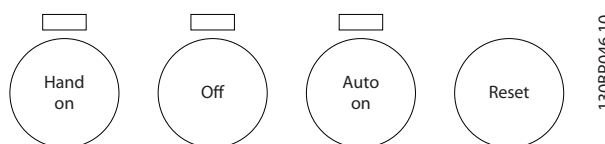

Figure 4.6 Operation Keys

Key	Function
<b>Hand On</b>	Starts the adjustable frequency drive in local control. <ul style="list-style-type: none"> <li>Use the navigation keys to control adjustable frequency drive speed.</li> <li>An external stop signal by control input or serial communication overrides the local hand on</li> </ul>
<b>Off</b>	Stops the motor but does not remove power to the adjustable frequency drive.
<b>Auto On</b>	Puts the system in remote operational mode. <ul style="list-style-type: none"> <li>Responds to an external start command by control terminals or serial communication</li> <li>Speed reference is from an external source</li> </ul>
<b>Reset</b>	Resets the adjustable frequency drive manually after a fault has been cleared.

Table 4.5 Operation Keys Functions

## 4.2 Backup and Copying Parameter Settings

Programming data is stored internally in the adjustable frequency drive.

- The data can be uploaded into the LCP memory as a storage backup.
- Once stored in the LCP, the data can be downloaded back into the adjustable frequency drive.
- Data can also be downloaded into other adjustable frequency drives by connecting the LCP into those units and downloading the stored settings. (This is a quick way to program multiple units with the same settings).
- Initialization of the adjustable frequency drive to restore factory default settings does not change data stored in the LCP memory.

## ⚠ WARNING

### UNINTENDED START!

When the adjustable frequency drive is connected to AC line power, the motor may start at any time. The adjustable frequency drive, motor, and any driven equipment must be in operational readiness. Failure to be in operational readiness when the adjustable frequency drive is connected to AC line power could result in death, serious injury, or equipment or property damage.

4

#### 4.2.1 Uploading Data to the LCP

1. Press [Off] to stop the motor before uploading or downloading data.
2. Go to *0-50 LCP Copy*.
3. Press [OK].
4. Select *All to LCP*.
5. Press [OK]. A progress bar shows the uploading process.
6. Press [Hand On] or [Auto On] to return to normal operation.

#### 4.2.2 Downloading Data from the LCP

1. Press [Off] to stop the motor before uploading or downloading data.
2. Go to *0-50 LCP Copy*.
3. Press [OK].
4. Select *All from LCP*.
5. Press [OK]. A progress bar shows the downloading process.
6. Press [Hand On] or [Auto On] to return to normal operation.

### 4.3 Restoring Default Settings

## CAUTION

Initialization restores the unit to factory default settings. Any programming, motor data, localization, and monitoring records will be lost. Uploading data to the LCP provides a backup before initialization.

Restoring the adjustable frequency drive parameter settings back to default values is done by initialization of the adjustable frequency drive. Initialization can be through *14-22 Operation Mode* or manually.

- Initialization using *14-22 Operation Mode* does not change adjustable frequency drive data such as operating hours, serial communication selections, personal menu settings, fault log, alarm log, and other monitoring functions
- Using *14-22 Operation Mode* is generally recommended.
- Manual initialization erases all motor, programming, localization, and monitoring data and restores factory default settings.

#### 4.3.1 Recommended Initialization

1. Press [Main Menu] twice to access parameters.
2. Scroll to *14-22 Operation Mode*.
3. Press [OK].
4. Scroll to *Initialization*.
5. Press [OK].
6. Remove power to the unit and wait for the display to turn off.
7. Apply power to the unit.

Default parameter settings are restored during start-up. This may take slightly longer than normal.

8. Alarm 80 is displayed.
9. Press [Reset] to return to operation mode.

#### 4.3.2 Manual Initialization

1. Remove power to the unit and wait for the display to turn off.
2. Press and hold [Status], [Main Menu], and [OK] at the same time and apply power to the unit.

Factory default parameter settings are restored during start-up. This may take slightly longer than normal.

Manual initialization does not reset the following adjustable frequency drive information

- *15-00 Operating hours*
- *15-03 Power-ups*
- *15-04 Over Temps*
- *15-05 Over Volts*

# 5 About Adjustable Frequency Drive Programming

## 5.1 Introduction

The adjustable frequency drive is programmed for its application functions using parameters. Parameters are accessed by pressing either [Quick Menu] or [Main Menu] on the LCP. (See 4 *User Interface* for details on using the LCP function keys.) Parameters may also be accessed through a PC using the MCT 10 Set-up Software (see 5.6 *Remote Programming with MCT 10 Set-up Software*).

The Quick Menu is intended for initial start-up (Q2-\*\* Quick Set-up) and detailed instructions for common adjustable frequency drive applications (Q3-\*\* *Function Set-up*). Step-by-step instructions are provided. These instructions enable the user to walk through the parameters used for programming applications in their proper sequence. Data entered in a parameter can change the options available in the parameters following that entry. The quick menu presents easy guidelines for getting most systems up and running.

The Quick Menu also contains Q7-\*\* *Water and Pumps* providing very quick access to all dedicated water and pump features of the VLT® AQUA Drive

The main menu accesses all parameters and allows for advanced adjustable frequency drive applications.

## 5.2 Programming Example

Here is an example for programming the adjustable frequency drive for a common application in open-loop.

- This procedure programs the adjustable frequency drive to receive a 0–10 V DC analog control signal on input terminal 53
- The adjustable frequency drive will respond by providing 6–60 Hz output to the motor proportional to the input signal (0–10 V DC = 6–60 Hz)

Select the following parameters using the navigation keys to scroll to the titles and press [OK] after each action.

1. 3-15 Reference 1 Source

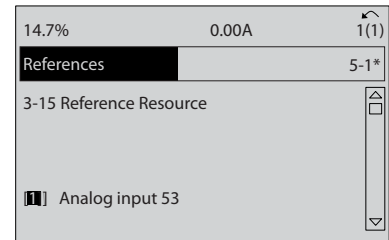

Figure 5.1 References 3-15 Reference 1 Source

2. 3-02 Minimum Reference. Set minimum internal adjustable frequency drive reference to 0 Hz. (This sets the minimum adjustable frequency drive speed at 0 Hz.)

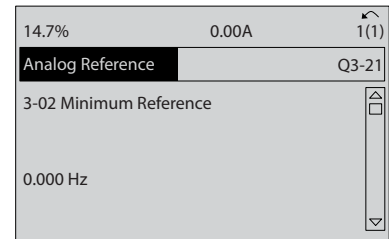

Figure 5.2 Analog Reference 3-02 Minimum Reference

3. 3-03 Maximum Reference. Set maximum internal adjustable frequency drive reference to 60 Hz. (This sets the maximum adjustable frequency drive speed at 60 Hz. Note that 50/60 Hz is a regional variation.)

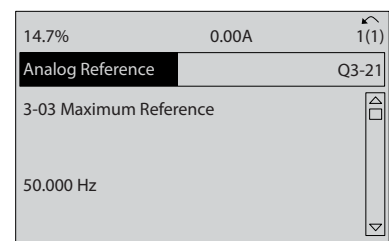

Figure 5.3 Analog Reference 3-03 Maximum Reference

- 6-10 Terminal 53 Low Voltage. Set minimum external voltage reference on Terminal 53 at 0 V. (This sets the minimum input signal at 0 V.)

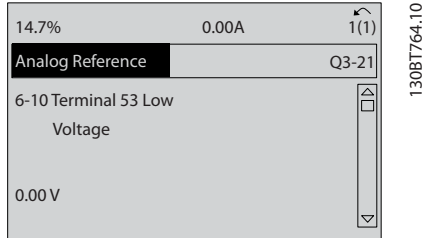

Figure 5.4 Analog Reference 6-10 Terminal 53 Low Voltage

- 6-11 Terminal 53 High Voltage. Set maximum external voltage reference on Terminal 53 at 10 V. (This sets the maximum input signal at 10 V.)

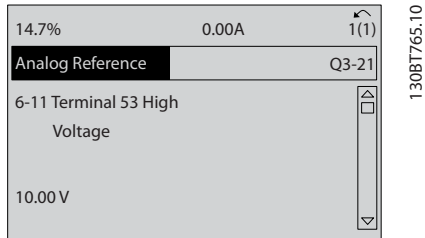

Figure 5.5 Analog Reference 6-11 Terminal 53 High Voltage

- 6-14 Terminal 53 Low Ref./Feedb. Value. Set minimum speed reference on Terminal 53 at 6 Hz. (This tells the adjustable frequency drive that the minimum voltage received on Terminal 53 (0 V) equals 6 Hz output.)

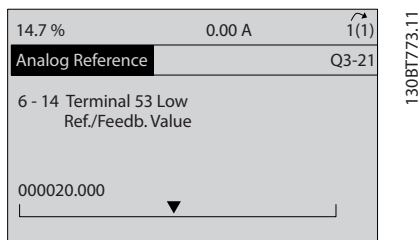

Figure 5.6 Analog Reference 6-14 Terminal 53 Low Ref./Feedb. Value

- 6-15 Terminal 53 High Ref./Feedb. Value. Set maximum speed reference on Terminal 53 at 60 Hz. (This tells the adjustable frequency drive that the maximum voltage received on Terminal 53 (10 V) equals 60 Hz output.)

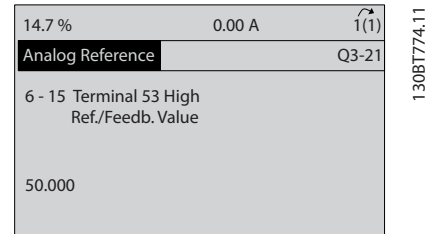

Figure 5.7 Analog Reference 6-15 Terminal 53 High Ref./Feedb. Value

With an external device providing a 0–10 V control signal connected to adjustable frequency drive terminal 53, the system is now ready for operation. Note that the scroll bar on the right in the last figure of the display is at the bottom, indicating the procedure is complete.

Figure 5.8 shows the wiring connections used to enable this set-up.

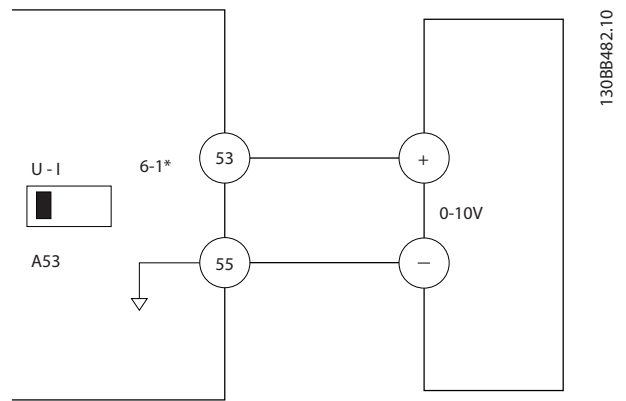

Figure 5.8 Wiring Example for External Device Providing 0–10 V Control Signal (Adjustable Frequency Drive Left, External Device Right)

### 5.3 Control Terminal Programming Examples

Control terminals can be programmed.

- Each terminal has specified functions it is capable of performing.
- Parameters associated with the terminal enable the function.

See *Table 2.4* for control terminal parameter number and default setting. (Default setting can change based on the selection in *0-03 Regional Settings*.)

The following example shows accessing Terminal 18 to see the default setting.

1. Press [Main Menu] twice, scroll to parameter group 5-\*\* *Digital In/Out* and press [OK].

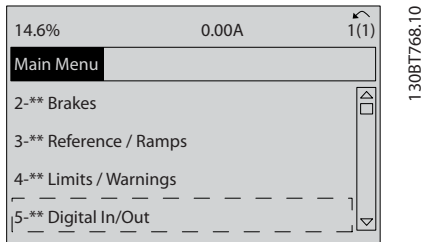

Figure 5.9 6-15 Terminal 53 High Ref./Feedb. Value

2. Scroll to parameter group 5-1\* *Digital Inputs* and press [OK].

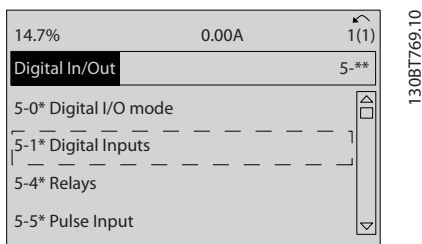

Figure 5.10 Digital In/Out

3. Scroll to *5-10 Terminal 18 Digital Input*. Press [OK] to access function choices. The default setting *Start* is shown.

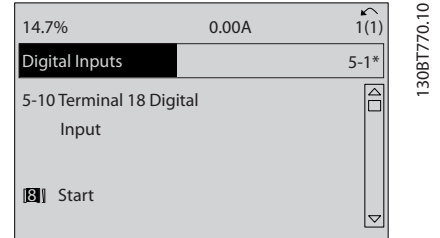

Figure 5.11 Digital Inputs

### 5.4 International/North American Default Parameter Settings

Setting *0-03 Regional Settings* to International or North America changes the default settings for some parameters. *Table 5.1* lists those parameters that are effected.

Parameter	International Default Parameter Value	North American Default Parameter Value
0-03 Regional Settings	International	North America
0-71 Date Format	YYYY-MM-DD	MM/DD/YYYY
0-72 Time Format	24h	12h
1-20 Motor Power [kW]	See Note 1	See Note 1
1-21 Motor Power [HP]	See Note 2	See Note 2
1-22 Motor Voltage	230 V/400 V/575 V	208 V/460 V/575 V
1-23 Motor Frequency	20–1000 Hz	60 Hz
3-03 Maximum Reference	50 Hz	60 Hz
3-04 Reference Function	Sum	External/Preset
4-13 Motor Speed High Limit [RPM] See Note 3	1500 RPM	1800 RPM
4-14 Motor Speed High Limit [Hz] See Note 4	50 Hz	60 Hz
4-19 Max Output Frequency	1.0–1000.0 Hz	120 Hz
4-53 Warning Speed High	1500 RPM	1800 RPM
5-12 Terminal 27 Digital Input	Coast inverse	External interlock
5-40 Function Relay	Alarm	No alarm

Parameter	International Default Parameter Value	North American Default Parameter Value
6-15 Terminal 53 High Ref./Feedb. Value	50	60
6-50 Terminal 42 Output	100	Speed 4-20 mA
14-20 Reset Mode	Automatic reset x 10	Infinite auto reset
22-85 Speed at Design Point [RPM] See Note 3	1500 RPM	1800 RPM
22-86 Speed at Design Point [Hz]	50 Hz	60 Hz

**Table 5.1 International/North American Default Parameter Settings**

- Note 1: 1-20 Motor Power [kW] is only visible when 0-03 Regional Settings is set to [0] International.
- Note 2: 1-21 Motor Power [HP], is only visible when 0-03 Regional Settings is set to [1] North America.
- Note 3: This parameter is only visible when 0-02 Motor Speed Unit is set to [0] RPM.
- Note 4: This parameter is only visible when 0-02 Motor Speed Unit is set to [1] Hz.

Changes made to default settings are stored and available for viewing in the quick menu along with any programming entered into parameters.

1. Press [Quick Menu].
2. Scroll to Q5 Changes Made and press [OK].

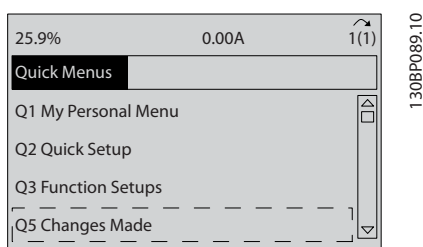

**Figure 5.12 Quick Menus**

3. Select Q5-2 *Since Factory Setting* to view all programming changes or Q5-1 *Last 10 Changes* for the most recent.

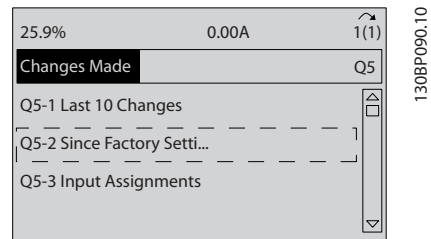

**Figure 5.13 Changes Made**

## 5.5 Parameter Menu Structure

Establishing the correct programming for applications often requires setting functions in several related parameters. These parameter settings provide the adjustable frequency drive with system details it needs to operate properly. System details may include such things as input and output signal types, programming terminals, minimum and maximum signal ranges, custom displays, automatic restart, and other features.

- See the LCP display to view detailed parameter programming and setting options.
- Press [Info] in any menu location to view additional details for that function.
- Press and hold [Main Menu] to enter a parameter number for direct access to that parameter
- Details for common application set-ups are provided in 6 *Application Set-up Examples*.

### 5.5.1 Quick Menu Structure

<b>Q2 Quick Set-up</b>	0-37 Display Text 1	20-12 Reference/Feedback Unit	Trending Comparison	29-13 Derag Speed [RPM]
0-01 Language	0-38 Display Text 2	3-02 Minimum Reference	<b>Q7 Water and Pumps</b>	29-14 Derag Speed [Hz]
0-02 Motor Speed Unit	0-39 Display Text 3	3-03 Maximum Reference	<b>Q7-1 Pipe Fill</b>	29-15 Derag Off Delay
1-20 Motor Power [kW]	<b>Q3-12 Analog Output</b>	6-20 Terminal 54 Low Voltage	<b>Q7-10 Horizontal Pipes</b>	29-22 Derag Power Factor
1-22 Motor Voltage	6-50 Terminal 42 Output	6-21 Terminal 54 High Voltage	29-00 Pipe Fill Enable	29-23 Derag Power Delay
1-23 Motor Frequency	6-51 Terminal 42 Output Min Scale	6-24 Terminal 54 Low Ref./Feedb. Value	29-01 Pipe Fill Speed [RPM]	29-24 Low Speed [RPM]
1-24 Motor Current	6-52 Terminal 42 Output Max Scale	6-25 Terminal 54 High Ref./Feedb. Value	29-02 Pipe Fill Speed [Hz]	29-25 Low Speed [Hz]
1-25 Motor Nominal Speed	<b>Q3-13 Relays</b>	6-00 Live Zero Timeout Time	29-03 Pipe Fill Time	29-26 Low Speed Power [kW]
	Option relays if applicable			
3-41 Ramp 1 Ramp-up Time	Relay 1 ⇒ 5-40 Function Relay	6-01 Live Zero Timeout Function	29-04 Pipe Fill Rate	29-27 Low Speed Power [HP]
3-42 Ramp 1 Ramp-down Time	Relay 2⇒ 5-40 Function Relay	<b>Q3-31 PID Settings</b>	29-05 Filled Setpoint	29-28 High Speed [RPM]
4-11 Motor Speed Low Limit [RPM]	<b>Q3-2 Open-loop Settings</b>	20-81 PID Normal/ Inverse Control	29-05 Filled Setpoint	29-29 High Speed [Hz]
4-13 Motor Speed High Limit [RPM]	<b>Q3-20 Digital Reference</b>	20-82 PID Start Speed [RPM]	29-06 No-Flow Disable Timer	29-30 High Speed Power [kW]
1-29 Automatic Motor Adaptation (AMA)	3-02 Minimum Reference	20-21 Setpoint 1	<b>Q7-11 Vertical Pipes</b>	29-31 High Speed Power [HP]
<b>Q3 Function Set-up</b>	3-03 Maximum Reference	20-93 PID Proportional Gain	29-00 Pipe Fill Enable	29-32 Derag On Ref Bandwidth
<b>Q3-1 General Settings</b>	3-10 Preset Reference	20-94 PID Integral Time	29-04 Pipe Fill Rate	<b>Q7-3 Dry Run</b>
<b>Q3-10 Clock Settings</b>	5-13 Terminal 29 Digital Input	<b>Q5 Changes Made</b>	29-05 Filled Setpoint	22-21 Low Power Detection
0-70 Date and Time	5-14 Terminal 32 Digital Input	<b>Q5-1 Last 10 Changes</b>	29-06 No-Flow Disable Timer	22-20 Low Power Auto Set-up
0-71 Date Format	5-15 Terminal 33 Digital Input	<b>Q5-2 Since Factory Setting</b>	<b>Q7-12 Mixed Systems</b>	22-27 Dry Pump Delay
0-72 Time Format	<b>Q3-21 Analog Reference</b>	<b>Q5-3 Input Assignments</b>	29-00 Pipe Fill Enable	22-26 Dry Pump Function
0-74 DST/Summertime	3-02 Minimum Reference	<b>Q6 Loggings</b>	29-01 Pipe Fill Speed [RPM]	<b>Q7-4 End of Curve Detection</b>
0-76 DST/Summertime Start	3-03 Maximum Reference	Reference [Unit]	29-02 Pipe Fill Speed [Hz]	22-50 End of Curve Function
0-77 DST_Summertime End	6-10 Terminal 53 Low Voltage	Analog Input 53	29-03 Pipe Fill Time	22-51 End of Curve Delay
<b>Q3-11 Display Settings</b>	6-11 Terminal 53 High Voltage	Motor current	29-05 Filled Setpoint	<b>Q7-5 Sleep Mode</b>
0-20 Display Line 1.1 Small	6-14 Terminal 53 Low Ref./Feedb. Value	Frequency	29-06 No-Flow Disable Timer	<b>Q7-50 Low Speed</b>
0-21 Display Line 1.2 Small	6-15 Terminal 53 High Ref./Feedb. Value	Feedback [Unit]	<b>Q7-2 Deragging</b>	22-22 Low Speed Detection
0-22 Display Line 1.3 Small	<b>Q3-3 Closed-loop Settings</b>	Energy Log	29-10 Derag Cycles	22-23 No-Flow Function
0-23 Display Line 2 Large	<b>Q3-30 Feedback Settings</b>	Trending Cont Bin	29-11 Derag at Start/Stop	22-24 No-Flow Delay
0-24 Display Line 3 Large	1-00 Configuration Mode	Trending Timed Bin	29-12 Deragging Run Time	22-28 No-Flow Low Speed [RPM]

Table 5.2 Quick Menu Structure

22-29 No-Flow Low Speed [Hz]	22-24 No-Flow Delay	22-20 Low Power Auto Set-up	<b>Q7-6 Flow Compensation</b>	22-90 Flow at Rated Speed
22-40 Minimum Run Time	22-20 Low Power Auto Set-up	22-22 Low Speed Detection	22-80 Flow Compensation	<b>Q7-7 Special Ramps</b>
22-41 Minimum Sleep Time	22-40 Minimum Run Time	22-28 No-Flow Low Speed [RPM]	22-81 Square-linear Curve Approximation	3-84 Initial Ramp Time
22-42 Wake-up Speed [RPM]	22-41 Minimum Sleep Time	22-29 No-Flow Low Speed [Hz]	22-82 Work Point Calculation	3-88 Final Ramp Time
22-43 Wake-up Speed [Hz]	22-42 Wake-up Speed [RPM]	22-40 Minimum Run Time	22-83 Speed at No-Flow [RPM]	3-85 Check Valve Ramp Time
22-44 Wake-up Ref./FB Difference	22-43 Wake-up Speed [Hz]	22-41 Minimum Sleep Time	22-84 Speed at No-Flow [Hz]	3-86 Check Valve Ramp End Speed [RPM]
22-45 Setpoint Boost	22-44 Wake-up Ref./FB Difference	22-42 Wake-up Speed [RPM]	22-85 Speed at Design Point [RPM]	3-87 Check Valve Ramp End Speed [Hz]
22-46 Maximum Boost Time	22-45 Setpoint Boost	22-43 Wake-up Speed [Hz]	22-86 Speed at Design Point [Hz]	
<b>Q7-51 Low Power</b>	22-46 Maximum Boost Time	22-44 Wake-up Ref./FB Difference	22-87 Pressure at No-Flow Speed	
22-21 Low Power Detection	<b>Q7-52 Low Speed/Power</b>	22-45 Setpoint Boost	22-88 Pressure at Rated Speed	
22-23 No-Flow Function	22-21 Low Power Detection	22-46 Maximum Boost Time	22-89 Flow at Design Point	

Table 5.3



0-89	Date and Time Readout	1-75	Start Speed [Hz]	3-90	Step Size	5-50	Term. 29 Low Frequency
1-89	<b>1-1*</b> <b>Load and Motor</b>	1-76	Start Current	3-91	Ramp Time	5-51	Term. 29 High Frequency
1-90	<b>1-0*</b> <b>General Settings</b>	1-80	<b>Stop Adjustments</b>	3-92	Power Restore	5-52	Term. 29 Low Ref./Feedb. Value
1-01	Configuration Mode	1-81	Function at Stop	3-93	Maximum Limit	5-53	Term. 29 High Ref./Feedb. Value
1-02	Motor Control Principle	1-82	Min Speed for Function at Stop [Hz]	3-94	Minimum Limit	5-54	Pulse Filter Time Constant #29
1-03	Torque Characteristics	1-83	Min Speed for Function at Stop [RPM]	3-95	Ramp Delay	5-55	Term. 33 Low Frequency
1-04	Torque Characteristic	1-84	Min Speed for Function at Stop [Hz]	4-1*	<b>Limits / Warnings</b>	5-56	Term. 33 High Frequency
1-05	Lockwise Direction	1-85	Trip Speed Low [Hz]	4-1*	<b>Motor Limits</b>	5-57	Term. 33 Low Ref./Feedb. Value
1-06	Motor Selection	1-86	Trip Speed Low [RPM]	4-1*	<b>Motor Warnings</b>	5-58	Term. 33 High Ref./Feedb. Value
1-07	Motor Construction	1-87	Trip Speed Low [Hz]	4-10	Motor Speed Direction	5-59	Pulse Filter Time Constant #33
1-08	Motor Construction	1-88	Motor Temperature	4-11	Motor Speed Low Limit [RPM]	5-6*	<b>Pulse Output</b>
1-09	Motor Construction	1-89	Motor Thermal Protection	4-11	Motor Speed Low Limit [Hz]	5-60	Terminal 27 Pulse Output Variable
1-10	Motor Construction	1-90	Motor External Fan	4-12	Motor Speed High Limit [RPM]	5-61	Pulse Output Max Freq #27
1-11	WCH-PM	1-91	Motor External Fan	4-13	Motor Speed High Limit [Hz]	5-62	Terminal 29 Pulse Output Variable
1-12	Damping Gain	1-92	Thermistor Source	4-14	Motor Speed High Limit [RPM]	5-63	Terminal 29 Pulse Output Variable
1-13	Low Speed Filter Time Const.	1-93	Brakes	4-16	Motor Speed High Limit [Hz]	5-64	Pulse Output Max Freq #29
1-14	High Speed Filter Time Const.	2-0*	<b>DC Brake</b>	4-17	Torque Limit Generator Mode	5-65	Pulse Output Max Freq #X30/6
1-15	Voltage filter time const.	2-00	DC Hold/Preheat Current	4-18	Current Limit	5-66	Terminal X30/6 Pulse Output Variable
1-16	<b>1-2*</b> <b>Motor Data</b>	2-01	DC Brake Current	4-19	Max Output Frequency	5-67	Pulse Output Max Freq #X30/6
1-17	Motor Power [kW]	2-02	DC Braking Time	4-5*	<b>Adj. Warnings</b>	5-8*	<b>I/O Options</b>
1-18	Motor Power [HP]	2-03	DC Brake Cut-in Speed [RPM]	4-50	Warning Current Low	5-80	AHF Cap Reconnect Delay
1-19	Motor Voltage	2-04	DC Brake Cut-in Speed [Hz]	4-51	Warning Current High	5-9*	<b>Bus Controlled</b>
1-20	Motor Frequency	2-06	Parking Current	4-52	Warning Speed Low	5-90	Digital & Relay Bus Control
1-21	Motor Current	2-07	Parking Time	4-53	Warning Speed High	5-93	Pulse Out #27 Bus Control
1-22	Motor Nominal Speed	2-1*	<b>Brake Energy Funct.</b>	4-54	Warning Reference Low	5-94	Pulse Out #27 Timeout Preset
1-23	Motor Rotation Check	2-10	Brake Function	4-55	Warning Reference High	5-95	Pulse Out #29 Bus Control
1-24	Automatic Motor Adaptation (AMA)	2-11	Brake Resistor (ohm)	4-56	Warning Feedback Low	5-96	Pulse Out #X30/6 Bus Control
1-25	<b>1-3*</b> <b>Addl. Motor Data</b>	2-12	Brake Power Limit (kW)	4-57	Warning Feedback High	5-97	Pulse Out #X30/6 Timeout Preset
1-26	Stator Resistance (Rs)	2-13	Brake Power Monitoring	4-58	Missing Motor Phase Function	5-98	Pulse Out #X30/6 Timeout Preset
1-27	Stator Resistance (Rr)	2-15	AC Brake Max. Current	4-60	<b>Speed Bypass</b>	6-0*	<b>Analog I/O/Out</b>
1-28	Rotor Leakage Reactance (X1)	2-16	Over-voltage Control	4-61	Bypass Speed From [RPM]	6-00	Live Zero Timeout Time
1-29	Rotor Leakage Reactance (X2)	2-17	Reference / Ramps	4-62	Bypass Speed From [Hz]	6-01	Live Zero Timeout Function
1-30	Main Reactance (Xh)	3-0*	<b>Reference Limits</b>	4-63	Bypass Speed To [Hz]	6-1*	<b>Analog Input 53</b>
1-31	Iron Loss Resistance (Rfe)	3-02	Minimum Reference	4-64	Semi-Auto Bypass Set-up	6-10	Terminal 53 Low Voltage
1-32	d-axis Inductance (Ld)	3-03	Maximum Reference	5-0*	<b>Digital I/O/Out</b>	6-11	Terminal 53 High Voltage
1-33	Motor Poles	3-04	Reference Function	5-00	Digital I/O Mode	6-12	Terminal 53 Low Current
1-34	Back EMF at 1000 RPM	3-1*	<b>References</b>	5-00	Digital I/O Mode	6-13	Terminal 53 High Current
1-35	Position Detection Gain	3-10	Preset Reference	5-01	Terminal 27 Mode	6-14	Terminal 53 Low Ref./Feedb. Value
1-36	Load-Indep. Setting	3-11	Jog Speed [Hz]	5-02	Terminal 29 Mode	6-15	Terminal 53 High Ref./Feedb. Value
1-37	Motor Magnetization at Zero Speed	3-13	Reference Site	5-1*	<b>Digital Inputs</b>	6-16	Terminal 53 Filter Time Constant
1-38	Min Speed Normal Magnetizing [RPM]	3-14	Preset Relative Reference	5-10	Terminal 18 Digital Input	6-17	Terminal 53 Live Zero
1-39	Min Speed Normal Magnetizing [Hz]	3-15	Reference 1 Source	5-11	Terminal 19 Digital Input	6-2*	<b>Analog Input 54</b>
1-40	V/f Characteristic - V	3-16	Reference 2 Source	5-12	Terminal 29 Digital Input	6-20	Terminal 54 Low Voltage
1-41	V/f Characteristic - f	3-17	Reference 3 Source	5-13	Terminal 27 Digital Input	6-21	Terminal 54 High Voltage
1-42	Flystart Test Pulses Current	3-19	Jog Speed [RPM]	5-14	Terminal 32 Digital Input	6-22	Terminal 54 Low Current
1-43	Flystart Test Pulses Frequency	3-4*	<b>Ramp 1</b>	5-15	Terminal 33 Digital Input	6-23	Terminal 54 High Current
1-44	<b>1-6*</b> <b>Load-Depend. Sett.</b>	3-41	Ramp 1 Ramp-up Time	5-16	Terminal X30/2 Digital Input	6-24	Terminal 54 Low Ref./Feedb. Value
1-45	High Speed Load Compensation	3-42	Ramp 1 Ramp-down Time	5-17	Terminal X30/3 Digital Input	6-25	Terminal 54 High Ref./Feedb. Value
1-46	Low Speed Load Compensation	3-51	<b>Ramp 2</b>	5-18	Terminal X30/4 Digital Input	6-26	Terminal 54 Filter Time Constant
1-47	Slip Compensation	3-52	Ramp 2 Ramp-up Time	5-19	Terminal 37 Digital Input	6-27	Terminal 54 Live Zero
1-48	Slip Compensation Time Constant	3-5*	Ramp 2 Ramp-down Time	5-30	<b>Digital Outputs</b>	6-3*	<b>Analog Input X30/11</b>
1-49	Resonance Dampening	3-8*	<b>Other Ramps</b>	5-30	Terminal 27 Digital Output	6-30	Terminal X30/11 Low Voltage
1-50	Resonance Dampening Time	3-80	Jog Ramp Time	5-31	Terminal 29 Digital Output	6-31	Terminal X30/11 High Voltage
1-51	Constant	3-81	Quick Stop Ramp Time	5-32	Term X30/6 Digi Out (MCB 101)	6-34	Term. X30/11 Low Ref./Feedb. Value
1-52	Min. Current at Low Speed	3-85	Initial Ramp Time	5-33	Term X30/7 Digi Out (MCB 101)	6-35	Term. X30/11 High Ref./Feedb. Value
1-53	<b>1-7*</b> <b>Start Adjustments</b>	3-86	Check Valve Ramp Time	5-4*	<b>Relays</b>	6-36	Term. X30/11 Filter Time Constant
1-54	PM Start Mode	3-87	Check Valve Ramp End Speed [RPM]	5-40	Function Relay	6-37	Term. X30/11 Live Zero
1-55	Start Delay	3-88	Check Valve Ramp End Speed [Hz]	5-41	On Delay, Relay	6-40	<b>6-4*</b> <b>Analog Input X30/12</b>
1-56	Start Function	3-9*	Final Ramp Time	5-42	Off Delay, Relay	6-40	Terminal X30/12 Low Voltage
1-57	Flying Start		Start Speed [RPM]	5-5*	<b>Pulse Input</b>	6-41	Terminal X30/12 High Voltage
1-58	Additional Non-Working Days						

5.5.2 Main Menu Structure

0-0*	<b>0-0*</b> <b>Operation/Display</b>
0-01	<b>0-0*</b> <b>Basic Settings</b>
0-02	Language
0-03	Motor Speed Unit
0-04	Regional Settings
0-05	Operating State at Power-up
0-06	Local Mode Unit
0-07	<b>0-1*</b> <b>Set-up Operations</b>
0-08	Active Set-up
0-09	Programming Set-up
0-10	This Set-up Linked to
0-11	Readout: Linked Set-ups
0-12	Readout: Prog. Set-ups / Channel
0-13	<b>0-2*</b> <b>LCP Display</b>
0-14	Display Line 1.1 Small
0-15	Display Line 1.2 Small
0-16	Display Line 1.3 Small
0-17	Display Line 2 Large
0-18	Display Line 3 Large
0-19	My Personal Menu
0-20	<b>0-3*</b> <b>LCP Cust. Readout</b>
0-21	Custom Readout Unit
0-22	Custom Readout Min Value
0-23	Custom Readout Max Value
0-24	Display Text 1
0-25	Display Text 2
0-26	Display Text 3
0-27	<b>0-4*</b> <b>LCP Keypad</b>
0-28	[Hand on] Key on LCP
0-29	[Off] Key on LCP
0-30	[Auto on] Key on LCP
0-31	[Reset] Key on LCP
0-32	[Off/Reset] Key on LCP
0-33	[Drive Bypass] Key on LCP
0-34	<b>0-5*</b> <b>Copy/Save</b>
0-35	LCP Copy
0-36	Set-up Copy
0-37	<b>0-6*</b> <b>Password</b>
0-38	Main Menu Password
0-39	Access to Main Menu w/o Password
0-40	Personal Menu Password
0-41	Access to Personal Menu w/o Password
0-42	Bus Password Access
0-43	<b>0-7*</b> <b>Clock Settings</b>
0-44	Date and Time
0-45	Date Format
0-46	Time Format
0-47	DST/Summertime Start
0-48	DST/Summertime End
0-49	Clock Fault
0-50	Working Days
0-51	Additional Working Days
0-52	Additional Non-Working Days

6-44	Term. X30/12 Low Ref./Feedb. Value	8-81	Bus Error Count	10-2*	<b>COS Filters</b>	12-93	Cable Error Length	14-53	Fan Monitor
6-45	Term. X30/12 High Ref./Feedb. Value	8-82	Slave Message Rcvd	10-20	COS Filter 1	12-94	Broadcast Storm Protection	14-55	Output Filter
6-46	Term. X30/12 Filter Time Constant	8-83	Slave Error Count	10-21	COS Filter 2	12-95	Broadcast Storm Filter	14-59	Actual Number of Inverter Units
6-47	Term. X30/12 Live Zero	8-9*	<b>Bus Jog</b>	10-22	COS Filter 3	12-96	Port Mirroring	14-6*	<b>Auto Derate</b>
6-50	Terminal 42 Output	8-91	Bus Jog 1 Speed	10-23	COS Filter 4	12-98	Interface Counters	14-60	Function at Overtemperature
6-51	Terminal 42 Output Min Scale	8-94	Bus Feedback 1	10-3*	<b>Parameter Access</b>	12-99	Media Counters	14-61	Function at Inverter Overload
6-52	Terminal 42 Output Max Scale	8-95	Bus Feedback 2	10-30	Array Index	13-3*	<b>Smart Logic</b>	14-62	Inv. Overload Derate Current
6-53	Terminal 42 Output Bus Control	8-96	Bus Feedback 3	10-31	Store Data Values	13-0*	<b>SLC Settings</b>	14-8*	<b>Options</b>
6-54	Terminal 42 Output Timeout Preset	9-9*	<b>PROhibitve</b>	10-32	Devenet Revision	13-00	SL Controller Mode	14-80	Option Supplied by External 24VDC
6-55	Terminal 42 Output Filter	9-00	Setpoint	10-33	Store Always	13-01	Start Event	14-9*	<b>Fault Settings</b>
6-56*	<b>Analog Output X30/8</b>	9-07	Actual Value	10-34	DeviceNet Product Code	13-02	Stop Event	14-90	Fault Level
6-60	Terminal X30/8 Output	9-15	PCD Write Configuration	10-39	DeviceNet F. Parameters	13-03	Reset SLC	15-*	<b>Drive Information</b>
6-61	Terminal X30/8 Min. Scale	9-16	PCD Read Configuration	12-*	<b>Ethernet</b>	13-1*	<b>Comparators</b>	15-0*	<b>Operating Data</b>
6-62	Terminal X30/8 Max. Scale	9-18	Node Address	12-00	IP Address Assignment	13-10	Comparator Operand	15-00	Operating Hours
6-63	Terminal X30/8 Output Bus Control	9-22	Telegram Selection	12-01	IP Address	13-11	Comparator Operator	15-01	Running Hours
6-64	Terminal X30/8 Output Timeout Preset	9-23	Parameters for Signals	12-02	Subnet Mask	13-12	Comparator Value	15-02	kWh Counter
		9-27	Parameter Edit	12-03	Default Gateway	13-2*	<b>Timers</b>	15-03	Power-ups
		9-28	Process Control	12-04	DHCP Server	13-20	SL Controller Timer	15-04	Over Temps
8-*	<b>Comm. and Options</b>	9-31	Safe Address	12-05	Lease Expires	13-4*	<b>Logic Rules</b>	15-05	Over Volts
8-01	Control Site	9-44	Fault Message Counter	12-06	Name Servers	13-40	Logic Rule Boolean 1	15-06	Reset kWh Counter
8-02	Control Source	9-45	Fault Code	12-07	Host Name	13-41	Logic Rule Operator 1	15-07	Reset Running Hours Counter
8-03	Control Timeout	9-47	Fault Number	12-08	Host Name	13-42	Logic Rule Boolean 2	15-08	Number of Starts
8-04	Control Timeout Function	9-52	Fault Situation Counter	12-09	Physical Address	13-43	Logic Rule Operator 2	15-1*	<b>Data Log Settings</b>
8-05	End-of-Timeout Function	9-53	Profibus Warning Word	12-10	Ethernet Link Parameters	13-44	Logic Rule Boolean 3	15-10	Logging Source
8-06	Reset Control Timeout	9-63	Actual Baud Rate	12-11	Link Status	13-5*	<b>States</b>	15-11	Logging Interval
8-07	Diagnosis Trigger	9-64	Device Identification	12-12	Link Duration	13-51	SL Controller Event	15-12	Logging Event
8-08	Readout Filtering	9-65	Profile Number	12-13	Auto Negotiation	13-52	SL Controller Action	15-13	Logging Mode
8-1*	<b>Control Settings</b>	9-67	Control Word 1	12-14	Link Speed	14-*	<b>Special Functions</b>	15-14	Samples Before Trigger
8-10	Control Profile	9-68	Status Word 1	12-20	Process Data	14-0*	<b>Inverter Switching</b>	15-2*	<b>Historic Log</b>
8-13	Configurable Status Word STW	9-71	Profibus Save Data Values	12-21	Control Instance	14-00	Switching Pattern	15-20	Historic Log: Event
8-14	Configurable Control Word CTW	9-72	ProfibusDriveReset	12-22	Process Data Config Write	14-01	Switching Frequency	15-21	Historic Log: Value
8-3*	<b>FC Port Settings</b>	9-75	DO Identification	12-27	Primary Master	14-03	Overmodulation	15-22	Historic Log: Time
8-30	Protocol	9-80	Defined Parameters (1)	12-29	Store Always	14-04	PWM Random	15-23	Historic Log: Date and Time
8-31	Address	9-81	Defined Parameters (2)	12-30	EtherNet/IP	14-1*	<b>Mains On/Off</b>	15-3*	<b>Alarm Log</b>
8-32	Baud Rate	9-82	Defined Parameters (3)	12-31	Warning Parameter	14-10	Mains Failure	15-30	Alarm Log: Error Code
8-33	Parity / Stop Bits	9-83	Defined Parameters (4)	12-32	Net Reference	14-11	Mains Voltage at Mains Fault	15-31	Alarm Log: Value
8-35	Minimum Response Delay	9-84	Defined Parameters (5)	12-33	Net Control	14-12	Function at Mains Imbalance	15-32	Alarm Log: Time
8-36	Max Response Delay	9-90	Changed Parameters (1)	12-34	CIP Revision	14-2*	<b>Reset Functions</b>	15-33	Alarm Log: Date and Time
8-37	Maximum Inter-Char Delay	9-91	Changed Parameters (2)	12-35	EDS Parameter	14-20	Reset Mode	15-34	Alarm Log: Setpoint
8-40	Telegram selection	9-92	Changed Parameters (3)	12-37	COS Inhibit Timer	14-21	Automatic Restart Time	15-35	Alarm Log: Feedback
8-42	PCD Write Configuration	9-94	Changed parameters (4)	12-38	COS Filter	14-22	Operation Mode	15-36	Alarm Log: Current Demand
8-43	PCD Read Configuration	9-99	Profibus Revision Counter	12-40	Modbus TCP	14-23	Typecode Setting	15-37	Alarm Log: Process Ctrl Unit
8-5*	<b>Digital/Bus</b>	10-*	<b>CAN Fields/Bus</b>	12-42	Slave Message Count	14-25	Trip Delay at Torque Limit	15-4*	<b>Drive Identification</b>
8-50	Coasting Select	10-0*	<b>Common Settings</b>	12-44	Other Ethernet Services	14-26	Trip Delay at Inverter Fault	15-40	FC Type
8-52	DC Brake Select	10-00	CAN Protocol	12-48	FTP Server	14-28	Production Settings	15-41	Power Section
8-53	Start Select	10-01	Baud Rate Select	12-80	HTTP Server	14-29	Service Code	15-42	Voltage
8-54	Reverse Select	10-02	MAC ID	12-81	HTTP Server	14-3*	<b>Current Lim Ctri.</b>	15-43	Software Version
8-55	Set-up Select	10-05	Readout Transmit Error Counter	12-82	SMTIP Service	14-30	Current Lim Ctri, Proportional Gain	15-44	Ordered Typecode String
8-56	Preset Reference Select	10-06	Readout Receive Error Counter	12-41	Slave Message Count	14-31	Current Lim Ctri, Integration Time	15-45	Actual Typecode String
8-7*	<b>BACnet</b>	10-07	Readout Bus Off Counter	12-42	Slave Exception Message Count	14-32	Current Lim Ctri, Filter Time	15-46	Adj Freq Dr Ordering No.
8-70	BACnet Device Instance	10-1*	<b>DeviceNet</b>	12-80	FTP Server	14-4*	<b>Energy Optimizing</b>	15-47	Power Card Ordering No.
8-72	MS/TP Max Masters	10-10	Process Data Type Selection	12-81	HTTP Server	14-40	VT Level	15-48	LCP ID Num.
8-73	MS/TP Max Info Frames	10-11	Process Data Config Write	12-82	SMTIP Service	14-41	AEO Minimum Magnetization	15-49	SW ID Control Card
8-74	"Startup I am"	10-12	Process Data Config Read	12-89	Transparent Socket Channel Port	14-42	Minimum AEO Frequency	15-50	SW ID Power Card
8-75	Initialisation Password	10-13	Warning Parameter	12-9*	<b>Advanced Ethernet Services</b>	14-43	Motor Cos-Phi	15-51	Adj Freq Dr Serial No.
8-8*	<b>FC Port Diagnostics</b>	10-14	Net Reference	12-90	Cable Diagnostic	14-5*	<b>Environment</b>	15-53	Power Card Serial Number
8-80	Bus Message Count	10-15	Net Control	12-91	MDI-X	14-50	RFI 1	15-59	CSIV Filename
				12-92	IGMP Snooping	14-52	Fan Control	15-60	<b>Option Ident</b>
									Option Mounted

15-61	Option SW Version	16-61	Terminal 53 Switch Setting	20-08	Feedback 3 Source Unit	21-4*	Ext. CL 2 PID	22-61	Broken Belt Torque
15-62	Option Ordering No	16-62	Analog Input 53	20-12	Reference/Feedback Unit	21-40	Ext. 2 Normal/Inverse Control	22-62	Broken Belt Delay
15-63	Option Serial No	16-63	Terminal 54 Switch Setting	20-2*	Feedback/Setpoint	21-41	Ext. 2 Proportional Gain	22-7*	Short Cycle Protection
15-70	Option in Slot A	16-64	Analog Input 54	20-20	Feedback Function	21-42	Ext. 2 Integral Time	22-75	Short Cycle Protection Interval between Starts
15-71	Slot A Option SW Version	16-65	Analog Output 42 [mA]	20-21	Setpoint 1	21-43	Ext. 2 Differentiation Time	22-76	Minimum Run Time
15-72	Option in Slot B	16-66	Digital Output [bin]	20-22	Setpoint 2	21-44	Ext. 2 Dif. Gain Limit	22-77	Minimum Run Time Override
15-73	Slot B Option SW Version	16-67	Pulse Input #29 [Hz]	20-23	Setpoint 3	21-5*	Ext. CL 3 Ref./FB.	22-78	Minimum Run Time
15-74	Option in Slot C0	16-68	Pulse Input #33 [Hz]	20-7*	PID Autotuning	21-50	Ext. 3 Ref./Feedback Unit	22-79	Minimum Run Time Override Value
15-75	Slot C0/E0 Option SW Version	16-69	Pulse Output #27 [Hz]	20-70	Closed-loop Type	21-51	Ext. 3 Minimum Reference	22-8*	Flow Compensation
15-76	Option in Slot C1	16-70	Pulse Output #29 [Hz]	20-71	PID Performance	21-52	Ext. 3 Maximum Reference	22-80	Flow Compensation
15-77	Slot C1/E1 Option SW Version	16-71	Relay Output [bin]	20-72	PID Output Change	21-53	Ext. 3 Reference Source	22-81	Square-linear Curve Approximation
15-9*	Parameter Info	16-72	Counter A	20-73	Minimum Feedback Level	21-54	Ext. 3 Feedback Source	22-82	Work Point Calculation
15-92	Defined Parameters	16-73	Counter B	20-74	Maximum Feedback Level	21-55	Ext. 3 Setpoint	22-83	Speed at No-Flow [RPM]
15-93	Modified Parameters	16-75	Analog In X30/11	20-79	PID Autotuning	21-57	Ext. 3 Reference [Unit]	22-84	Speed at No-Flow [Hz]
15-98	Drive Identification	16-76	Analog In X30/12	20-8*	PID Basic Settings	21-58	Ext. 3 Feedback [Unit]	22-85	Speed at Design Point [RPM]
15-99	Parameter Metadata	16-77	Analog Out X30/8 [mA]	20-81	PID Normal/ Inverse Control	21-59	Ext. 3 Output [%]	22-86	Speed at Design Point [Hz]
16-1*	Data Readouts	16-78*	Fieldbus & FC Port	20-82	PID Start Speed [RPM]	21-6*	Ext. CL 3 PID	22-87	Pressure at Rated Speed
16-0*	General Status	16-80	Fieldbus CTW 1	20-83	PID Start Speed [Hz]	21-60	Ext. 3 Normal/Inverse Control	22-88	Pressure at Rated Speed
16-00	Control Word	16-82	Fieldbus REF 1	20-84	On Reference Bandwidth	21-61	Ext. 3 Proportional Gain	22-89	Flow at Design Point
16-01	Reference [Unit]	16-84	Comm. Option Status	20-9*	PID Controller	21-62	Ext. 3 Integral Time	22-90	Flow at Rated Speed
16-02	Reference [%]	16-85	FC Port CTW 1	20-91	PID Anti Windup	21-63	Ext. 3 Differentiation Time	23-1*	Time-based Functions
16-03	Status Word	16-86	FC Port REF 1	20-93	PID Proportional Gain	21-64	Ext. 3 Dif. Gain Limit	23-0*	Timed Actions
16-05	Main Actual Value [%]	16-9*	Diagnosis Readouts	20-94	PID Integral Time	22-2*	Application Functions	23-00	ON Time
16-09	Custom Readout	16-90	Alarm Word	20-95	PID Differentiation Time	22-0*	Miscellaneous	23-01	ON Action
16-1*	Motor Status	16-91	Alarm Word 2	20-96	PID Diff. Gain Limit	22-2*	No-Flow Detection	23-02	OFF Time
16-10	Power [kW]	16-92	Warning Word	21-1*	Ext. Closed-loop	22-2*	No-Flow Detection	23-03	OFF Action
16-11	Power [hp]	16-93	Warning Word 2	21-0*	Ext. CL Autotuning	22-20	Low Power Auto Set-up	23-04	Occurrence
16-12	Motor voltage	16-94	Ext. Status Word 2	21-00	Closed-loop Type	22-21	Low Power Detection	23-1*	Maintenance
16-13	Frequency	16-95	Ext. Status Word 2	21-01	PID Performance	22-22	Low Speed Detection	23-10	Maintenance Action
16-14	Motor current	16-96	Maintenance Word	21-02	PID Output Change	22-23	No-Flow Function	23-11	Maintenance Item
16-15	Frequency [%]	18-1*	Info & Readouts	21-03	Minimum Feedback Level	22-24	No-Flow Delay	23-12	Maintenance Time Base
16-16	Torque [Nm]	18-0*	Maintenance Log	21-04	Maximum Feedback Level	22-26	Dry Pump Delay	23-13	Maintenance Time Interval
16-17	Speed [RPM]	18-01	Maintenance Log: Item	21-09	PID Auto Tuning	22-27	Dry Pump Delay	23-14	Maintenance Date and Time
16-18	Motor Thermal	18-01	Maintenance Log: Action	21-1*	Ext. CL 1 Ref./FB.	22-28	No-Flow Low Speed [RPM]	23-15	Maintenance Reset
16-20	Motor Angle	18-02	Maintenance Log: Time	21-10	Ext. 1 Ref./Feedback Unit	22-29	No-Flow Low Speed [Hz]	23-15	Reset Maintenance Word
16-22	Torque [%]	18-03	Maintenance Log: Date and Time	21-11	Ext. 1 Minimum Reference	22-30	No-Flow Power	23-16	Maintenance Text
16-3*	Drive Status	18-3*	Inputs & Outputs	21-12	Ext. 1 Maximum Reference	22-30	No-Flow Power	23-5*	Energy Log
16-30	DC Link Voltage	18-30	Analog Input X42/1	21-13	Ext. 1 Reference Source	22-31	Power Correction Factor	23-50	Energy Log Resolution
16-32	Brake Energy /s	18-31	Analog Input X42/3	21-14	Ext. 1 Feedback Source	22-32	Low Speed [RPM]	23-51	Period Start
16-33	Brake Energy /2 min	18-32	Analog Input X42/5	21-15	Ext. 1 Setpoint	22-33	Low Speed [Hz]	23-53	Energy Log
16-34	Heatsink Temp.	18-33	Analog Out X42/7 [V]	21-17	Ext. 1 Reference [Unit]	22-34	Low Speed Power [kW]	23-54	Reset Energy Log
16-35	Inverter Thermal	18-34	Analog Out X42/9 [V]	21-18	Ext. 1 Feedback [Unit]	22-35	Low Speed Power [HP]	23-6*	Trending
16-36	Inv. Nom. Current	18-35	Analog Out X42/11 [V]	21-19	Ext. 1 Output [%]	22-36	High Speed [RPM]	23-60	Trend Variable
16-37	Inv. Max. Current	18-36	Analog Input X48/2 [mA]	21-2*	Ext. CL 1 PID	22-37	High Speed [Hz]	23-61	Continuous Bin Data
16-38	SL Controller State	18-37	Temp. Input X48/4	21-20	Ext. 1 Normal/Inverse Control	22-38	High Speed Power [kW]	23-62	Timed Bin Data
16-39	Control Card Temp.	18-38	Temp. Input X48/7	21-21	Ext. 1 Proportional Gain	22-39	High Speed Power [HP]	23-63	Timed Period Start
16-40	Logging Buffer Full	18-39	Temp. Input X48/10	21-22	Ext. 1 Integral Time	22-40	Sleep Mode	23-64	Timed Period Stop
16-49	Current Fault Source	18-6*	Inputs & Outputs 2	21-23	Ext. 1 Differentiation Time	22-40	Minimum Run Time	23-65	Minimum Bin Value
16-5*	Ref. & Feeds.	18-60	Digital Input 2	21-24	Ext. 1 Gain Limit	22-41	Minimum Run Time	23-66	Reset Continuous Bin Data
16-50	External Reference	20-2*	Drive Closed-loop	21-3*	Ext. CL 2 Ref./FB.	22-42	Wake-up Speed [RPM]	23-67	Reset Timed Bin Data
16-52	Feedback [Unit]	20-0*	Feedback	21-30	Ext. 2 Ref./Feedback Unit	22-43	Wake-up Speed [Hz]	23-6*	Payback Counter
16-53	Digi Pot Reference	20-00	Feedback 1 Source	21-31	Ext. 2 Minimum Reference	22-44	Wake-up Ref./FB Difference	23-80	Power Reference Factor
16-54	Feedback 1 [Unit]	20-01	Feedback 1 Conversion	21-32	Ext. 2 Maximum Reference	22-45	Setpoint Boost	23-81	Energy Cost
16-55	Feedback 2 [Unit]	20-02	Feedback 2 Source Unit	21-33	Ext. 2 Reference Source	22-46	Maximum Boost Time	23-82	Investment
16-56	Feedback 3 [Unit]	20-03	Feedback 2 Source	21-34	Ext. 2 Feedback Source	22-5*	End of Curve	23-83	Energy Savings
16-58	PID Output [%]	20-04	Feedback 2 Conversion	21-35	Ext. 2 Setpoint	22-50	End of Curve Function	23-84	Cost Savings
16-59	Adjusted Setpoint	20-05	Feedback 2 Source Unit	21-37	Ext. 2 Reference [Unit]	22-51	End of Curve Delay	24-1*	Drive Bypass
16-6*	Inputs & Outputs	20-06	Feedback 3 Source	21-38	Ext. 2 Feedback [Unit]	22-6*	Broken Belt Detection	24-10	Drive Bypass Function
16-60	Digital Input	20-07	Feedback 3 Conversion	21-39	Ext. 2 Output [%]				

24-11 Drive Bypass Delay Time	26-15 Term. X42/1 High Ref./Feedb. Value	27-30 Auto Tune Staging Speeds	29-20 Derag Power[kW]
<b>25-0*</b> Cascade Controller	26-16 Term. X42/1 Filter Time Constant	27-31 Stage On Speed [RPM]	29-21 Derag Power[HP]
<b>25-0*</b> System Settings	26-17 Term. X42/1 Live Zero	27-32 Stage On Speed [Hz]	29-22 Derag Power Factor
25-00 Cascade Controller	<b>26-2*</b> Analog Input X42/3	27-33 Stage Off Speed [RPM]	29-23 Derag Power Delay
25-02 Motor Start	26-20 Terminal X42/3 Low Voltage	27-34 Stage Off Speed [Hz]	29-24 Low Speed [RPM]
25-04 Pump Cycling	26-21 Terminal X42/3 High Voltage	<b>27-4*</b> Staging Settings	29-25 Low Speed [Hz]
25-05 Fixed Lead Pump	26-24 Term. X42/3 Low Ref./Feedb. Value	27-40 Auto Tune Staging Settings	29-26 Low Speed Power [kW]
25-06 Number Of Pumps	26-25 Term. X42/3 High Ref./Feedb. Value	27-41 Ramp Down Delay	29-27 Low Speed Power [HP]
<b>25-2*</b> Bandwidth Settings	26-26 Term. X42/3 Filter Time Constant	27-42 Ramp Up Delay	29-28 High Speed [RPM]
25-20 Staging Bandwidth	26-27 Term. X42/3 Live Zero	27-43 Staging Threshold	29-29 High Speed [Hz]
25-21 Override Bandwidth	<b>26-3*</b> Analog Input X42/5	27-44 Destaging Threshold	29-30 High Speed Power [kW]
25-22 Fixed Speed Bandwidth	26-30 Terminal X42/5 Low Voltage	27-45 Staging Speed [RPM]	29-31 High Speed Power [HP]
25-23 5BW Staging Delay	26-31 Terminal X42/5 High Voltage	27-46 Staging Speed [Hz]	29-32 Derag On Ref Bandwidth
25-24 5BW De-staging Delay	26-34 Term. X42/5 Low Ref./Feedb. Value	27-47 Destaging Speed [RPM]	29-33 Power Derag Limit
25-25 OBW Time	26-35 Term. X42/5 High Ref./Feedb. Value	27-48 Destaging Speed [Hz]	29-34 Consecutive Derag Interval
25-26 Destage At No-Flow	26-36 Term. X42/5 Filter Time Constant	<b>27-5*</b> Alternate Settings	<b>30-*</b> Special Features
25-27 Stage Function	26-37 Term. X42/5 Live Zero	27-50 Automatic Alternation	<b>30-8*</b> Compatibility (I)
25-28 Stage Function Time	<b>26-4*</b> Analog Out X42/7	27-51 Alternation Event	30-81 Brake Resistor (ohm)
25-29 Destage Function	26-40 Terminal X42/7 Output	27-52 Alternation Time Interval	<b>31-*</b> Bypass Option
25-30 Destage Function Time	26-41 Terminal X42/7 Min. Scale	27-53 Alternation Timer Value	31-00 Bypass Mode
<b>25-4*</b> Staging Settings	26-42 Terminal X42/7 Max. Scale	27-54 Alternation At Time of Day	31-01 Bypass Start Time Delay
25-40 Ramp-down Delay	26-43 Terminal X42/7 Bus Control	27-55 Alternation Predefined Time	31-02 Bypass Trip Time Delay
25-41 Ramp-up Delay	26-44 Terminal X42/7 Timeout Preset	27-56 Alternate Capacity is <	31-03 Test Mode Activation
25-42 Staging Threshold	<b>26-5*</b> Analog Out X42/9	27-58 Run Next Pump Delay	31-10 Bypass Status Word
25-43 De-staging Threshold	26-50 Terminal X42/9 Output	<b>27-6*</b> Digital Inputs	31-11 Bypass Running Hours
25-44 Staging Speed [RPM]	26-51 Terminal X42/9 Min. Scale	27-60 Terminal X66/1 Digital Input	31-19 Remote Bypass Activation
25-45 Staging Speed [Hz]	26-52 Terminal X42/9 Max. Scale	27-61 Terminal X66/3 Digital Input	<b>35-*</b> Sensor Input Option
25-46 De-staging Speed [RPM]	26-53 Terminal X42/9 Bus Control	27-62 Terminal X66/5 Digital Input	<b>35-0*</b> Temp. Input Mode
25-47 De-staging Speed [Hz]	26-54 Terminal X42/9 Timeout Preset	27-63 Terminal X66/7 Digital Input	35-00 Term. X48/4 Temp. Unit
<b>25-5*</b> Alternation Settings	<b>26-6*</b> Analog Out X42/11	27-64 Terminal X66/9 Digital Input	35-01 Term. X48/4 Input Type
25-50 Lead Pump Alternation	26-60 Terminal X42/11 Output	27-65 Terminal X66/11 Digital Input	35-02 Term. X48/7 Temp. Unit
25-51 Alternation Event	26-61 Terminal X42/11 Min. Scale	27-66 Terminal X66/13 Digital Input	35-03 Term. X48/7 Input Type
25-52 Alternation Time Interval	26-62 Terminal X42/11 Max. Scale	<b>27-7*</b> Connections	35-04 Term. X48/10 Temp. Unit
25-53 Alternation Timer Value	26-63 Terminal X42/11 Bus Control	27-70 Relay	35-05 Term. X48/10 Input Type
25-54 Alternation Predefined Time	26-64 Terminal X42/11 Timeout Preset	<b>27-9*</b> Readouts	35-06 Temperature Sensor Alarm Function
25-55 Alternate if Load < 50%	<b>27-*</b> Cascade Ctl Option	27-91 Cascade Reference	<b>35-1*</b> Temp. Input X48/4
25-56 Staging Mode at Alternation	<b>27-0*</b> Control & Status	27-92 % Of Total Capacity	35-14 Term. X48/4 Filter Time Constant
25-58 Run Next Pump Delay	27-01 Pump Status	27-93 Cascade Option Status	35-15 Term. X48/4 Temp. Monitor
25-59 Run-on Line Delay	27-02 Manual Pump Control	27-94 Cascade System Status	35-16 Term. X48/4 Low Temp. Limit
<b>25-8*</b> Status	27-03 Current Runtime Hours	27-95 Advanced Cascade Relay Output [bin]	35-17 Term. X48/4 High Temp. Limit
25-80 Cascade Status	27-04 Pump Total Lifetime Hours	27-96 Extended Cascade Relay Output [bin]	<b>35-2*</b> Temp. Input X48/7
25-81 Pump Status	<b>27-1*</b> Configuration	<b>29-*</b> Water Application Functions	35-24 Term. X48/7 Filter Time Constant
25-82 Lead Pump	27-10 Cascade Controller	<b>29-0*</b> Pipe Fill	35-25 Term. X48/7 Temp. Monitor
25-83 Relay Status	27-11 Number Of Drives	29-00 Pipe Fill Enable	35-26 Term. X48/7 Low Temp. Limit
25-84 Pump ON Time	27-12 Number Of Pumps	29-01 Pipe Fill Speed [RPM]	35-27 Term. X48/7 High Temp. Limit
25-85 Relay ON Time	27-14 Pump Capacity	29-02 Pipe Fill Speed [Hz]	<b>35-3*</b> Temp. Input X48/10
25-86 Reset Relay Counters	27-16 Runtime Balancing	29-03 Pipe Fill Time	35-34 Term. X48/10 Filter Time Constant
<b>25-9*</b> Service	27-17 Motor Starters	29-04 Pipe Fill Rate	35-35 Term. X48/10 Temp. Monitor
25-90 Pump Interlock	27-18 Spin Time for Unused Pumps	29-05 Filled Setpoint	35-36 Term. X48/10 Low Temp. Limit
25-91 Manual Alternation	27-19 Reset Current Runtime Hours	29-06 No-Flow Disable Timer	35-37 Term. X48/10 High Temp. Limit
<b>26-*</b> Analog I/O Option	<b>27-2*</b> Bandwidth Settings	<b>29-1*</b> Deragging Function	<b>35-4*</b> Analog Input X48/2
26-00 Terminal X42/1 Mode	27-20 Normal Operating Range	29-10 Derag Cycles	35-42 Term. X48/2 Low Current
26-01 Terminal X42/3 Mode	27-21 Override Limit	29-11 Derag at Start/Stop	35-43 Term. X48/2 High Current
26-02 Terminal X42/5 Mode	27-22 Fixed Speed Only Operating Range	29-12 Deragging Run Time	35-45 Term. X48/2 Low Ref./Feedb. Value
<b>26-1*</b> Analog Input X42/1	27-23 Staging Delay	29-13 Derag Speed [RPM]	35-46 Term. X48/2 High Ref./Feedb. Value
26-10 Terminal X42/1 Low Voltage	27-24 Destaging Delay	29-14 Derag Speed [Hz]	35-47 Term. X48/2 Filter Time Constant
26-11 Terminal X42/1 High Voltage	27-25 Override Hold Time	29-15 Derag Off Delay	
26-14 Term. X42/1 Low Ref./Feedb. Value	27-27 Min Speed Destage Delay	<b>29-2*</b> Derag Power Tuning	

## 5.6 Remote Programming with MCT 10 Set-up Software

Danfoss has a software program available for developing, storing, and transferring adjustable frequency drive programming. The MCT 10 Set-up Software allows the user to connect a PC to the adjustable frequency drive and perform live programming rather than using the LCP. Additionally, all adjustable frequency drive programming can be done off-line and simply downloaded to the adjustable frequency drive. Or the entire adjustable frequency drive profile can be loaded onto the PC for backup storage or analysis.

The USB connector or RS-485 terminal is available for connecting to the adjustable frequency drive.

MCT 10 Set-up Software is available for free download at [www.VLT-software.com](http://www.VLT-software.com). A CD is also available by requesting part number 130B1000. For further information, see the Instruction Manual.



## 6 Application Set-up Examples

### 6.1 Introduction

#### NOTE!

When the optional safe stop feature is used, a jumper wire may be required between terminal 12 (or 13) and terminal 37 for the adjustable frequency drive to operate when using factory default programming values.

The examples in this section are intended as a quick reference for common applications.

- Parameter settings are the regional default values unless otherwise indicated (selected in *0-03 Regional Settings*)
- Parameters associated with the terminals and their settings are shown next to the drawings.
- Where switch settings for analog terminals A53 or A54 are required, these are also shown.

### 6.2 Application Examples

		Parameters	
FC		Function	Setting
+24 V	12		
+24 V	13	6-22 Terminal 54 Low Current	4 mA*
D IN	18		
D IN	19	6-23 Terminal 54 High Current	20 mA*
COM	20		
D IN	27		
D IN	29	6-24 Terminal 54 Low Ref./Feedb. Value	0*
D IN	32		
D IN	33	6-25 Terminal 54 High Ref./Feedb. Value	50*
D IN	37		
* = Default Value		Notes/comments:	
A 54			

Table 6.1 Analog Current Feedback Transducer

		Parameters	
FC		Function	Setting
+24 V	12		
+24 V	13	6-20 Terminal 54 Low Voltage	0.07 V*
D IN	18		
D IN	19	6-21 Terminal 54 High Voltage	10 V*
COM	20		
D IN	27		
D IN	29	6-24 Terminal 54 Low Ref./Feedb. Value	0*
D IN	32		
D IN	33	6-25 Terminal 54 High Ref./Feedb. Value	50*
D IN	37		
* = Default Value		Notes/comments:	
A 54			

Table 6.2 Analog Voltage Feedback Transducer (3-wire)

		Parameters	
FC		Function	Setting
+24 V	12		
+24 V	13	6-20 Terminal 54 Low Voltage	0.07 V*
D IN	18		
D IN	19	6-21 Terminal 54 High Voltage	10 V*
COM	20		
D IN	27		
D IN	29	6-24 Terminal 54 Low Ref./Feedb. Value	0*
D IN	32		
D IN	33	6-25 Terminal 54 High Ref./Feedb. Value	50*
D IN	37		
* = Default Value		Notes/comments:	
A 54			

Table 6.3 Analog Voltage Feedback Transducer (4-wire)

		Parameters	
FC		Function	Setting
+24 V	12		
+24 V	13	6-10 Terminal 53	
D IN	18	Low Voltage	0.07 V*
D IN	19	6-11 Terminal 53	
COM	20	High Voltage	10 V*
D IN	27	6-14 Terminal 53	
D IN	29	Low Ref./Feedb. Value	0*
D IN	32		
D IN	33	6-15 Terminal 53	
D IN	37	High Ref./Feedb. Value	50*
+10 V	50	* = Default Value	
A IN	53	Notes/comments:	
A IN	54		
COM	55		
A OUT	42		
COM	39		
A53			

Table 6.4 Analog Speed Reference (Voltage)

**NOTE!**

Note switch setting for selecting voltage or current.

		Parameters	
FC		Function	Setting
+24 V	12		
+24 V	13		
D IN	18	5-10 Terminal 18	[8] Start*
D IN	19	Digital Input	
COM	20	5-12 Terminal 27	[7] External Interlock
D IN	27	Digital Input	
D IN	29	* = Default Value	
D IN	32	Notes/comments:	
D IN	33		
D IN	37		
+10 V	50		
A IN	53		
A IN	54		
COM	55		
A OUT	42		
COM	39		
A53			

Table 6.6 Run/Stop Command with External Interlock

**NOTE!**

Note switch setting for selecting voltage or current.

		Parameters	
FC		Function	Setting
+24 V	12		
+24 V	13	6-12 Terminal 53	4 mA*
D IN	18	Low Current	
D IN	19	6-13 Terminal 53	20 mA*
COM	20	High Current	
D IN	27	6-14 Terminal 53	
D IN	29	Low Ref./Feedb. Value	0*
D IN	32		
D IN	33	6-15 Terminal 53	
D IN	37	High Ref./Feedb. Value	50*
+10 V	50	* = Default Value	
A IN	53	Notes/comments:	
A IN	54		
COM	55		
A OUT	42		
COM	39		
A53			

Table 6.5 Analog Speed Reference (Current)



		Parameters	
FC		Function	Setting
+24 V	12		
+24 V	13		
D IN	18	5-10 Terminal 18 Digital Input	[8] Start*
D IN	19		
COM	20		
D IN	27	5-12 Terminal 27 Digital Input	[7] External Interlock
D IN	29		
D IN	32		
D IN	33		
D IN	37		
+10 V	50		
A IN	53		
A IN	54		
COM	55		
A OUT	42		
COM	39		
	01		
	02		
	03		
	04		
	05		
	06		

130BB681.10

\* = Default Value

**Notes/comments:**  
If 5-12 Terminal 27 Digital Input is set to [0] No operation, a jumper wire to terminal 27 is not needed.

Table 6.7 Run/Stop Command without External Interlock

		Parameters	
FC		Function	Setting
+24 V	12		
+24 V	13		
D IN	18		
D IN	19	5-11 Terminal 19 Digital Input	[1] Reset
COM	20		
D IN	27		
D IN	29		
D IN	32		
D IN	33		
D IN	37		
+10 V	50		
A IN	53		
A IN	54		
COM	55		
A OUT	42		
COM	39		

130BB682.10

\* = Default Value

**Notes/comments:**

Table 6.8 External Alarm Reset

		Parameters	
FC		Function	Setting
+24 V	12		
+24 V	13		
D IN	18	6-10 Terminal 53 Low Voltage	0.07 V*
D IN	19	6-11 Terminal 53 High Voltage	10 V*
COM	20		
D IN	27		
D IN	29	6-14 Terminal 53 Low Ref./Feedb. Value	0*
D IN	32		
D IN	33		
D IN	37	6-15 Terminal 53 High Ref./Feedb. Value	50*
+10 V	50		
A IN	53		
A IN	54		
COM	55		
A OUT	42		
COM	39		

130BB683.10

≈ 5kΩ

\* = Default Value

**Notes/comments:**

U - I

A53

Table 6.9 Speed Reference (using a manual potentiometer)

		Parameters	
FC		Function	Setting
+24 V	12		
+24 V	13		
D IN	18	5-10 Terminal 18 Digital Input	[8] Start*
D IN	19	5-11 Terminal 19 Digital Input	[52] Run Permissive
COM	20		
D IN	27	5-12 Terminal 27 Digital Input	[7] External Interlock
D IN	29		
D IN	32		
D IN	33		
D IN	37	5-40 Function Relay	[167] Start command act.
+10 V	50		
A IN	53		
A IN	54		
COM	55		
A OUT	42		
COM	39		

130BB684.10

\* = Default Value

**Notes/comments:**

RE1

RE2

Table 6.10 Run Permissive

		Parameters	
FC		Function	Setting
+24 V	120		
+24 V	130	8-30 Protocol	FC*
D IN	180	8-31 Address	1*
D IN	190	8-32 Baud Rate	9600*
COM	200	* = Default Value	
D IN	270	<b>Notes/comments:</b>	
D IN	290	Select protocol, address and	
D IN	320	baud rate in the above	
D IN	330	mentioned parameters.	
D IN	370		
+10 V	500		
A IN	530		
A IN	540		
COM	550		
A OUT	420		
COM	390		

Table 6.11 RS-485 Network Connection (N2, Modbus RTU, FC)

### CAUTION

Thermistors must use reinforced or double insulation to meet PELV insulation requirements.

		Parameters	
FC		Function	Setting
+24 V	120		
+24 V	130	1-90 Motor Thermal Protection	[2]
D IN	180		Thermistor trip
D IN	190		
COM	200	1-93 Thermistor Source	[1] Analog input 53
D IN	270	* = Default Value	
D IN	290	<b>Notes/comments:</b>	
D IN	320	If only a warning is desired,	
D IN	330	1-90 Motor Thermal Protection	
D IN	370	should be set to [1] Thermistor	
+10 V	500	warning.	
A IN	530		
A IN	540		
COM	550		
A OUT	420		
COM	390		

Table 6.12 Motor Thermistor

## 7 Status Messages

### 7.1 Status Display

When the adjustable frequency drive is in status mode, status messages are generated automatically from within the adjustable frequency drive and appear in the bottom line of the display (see *Figure 7.1.*)

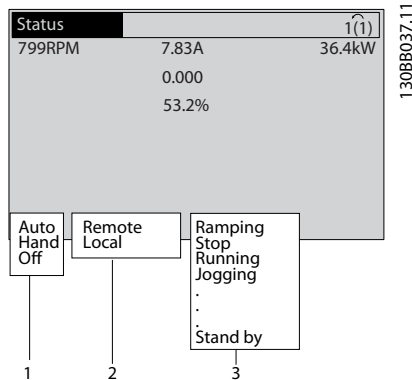

Figure 7.1 Status Display

- The first part of the status line indicates where the stop/start command originates.
- The second part of the status line indicates where the speed control originates.
- The last part of the status line gives the present adjustable frequency drive status. These show the operational mode the adjustable frequency drive is in.

### NOTE!

In auto/remote mode, the adjustable frequency drive requires external commands to execute functions.

### 7.2 Status Message Definitions

The next three tables define the meaning of the status message display words.

	Operation Mode
Off	The adjustable frequency drive does not react to any control signal until [Auto On] or [Hand On] is pressed.
Auto On	The adjustable frequency drive is controlled from the control terminals and/or the serial communication.
	The navigation keys on the LCP control the adjustable frequency drive. Stop commands, reset, reversing, DC brake, and other signals applied to the control terminals can override local control.

Table 7.1 Status Message Operation Mode

	Reference Site
Remote	The speed reference is given from external signals, serial communication, or internal preset references.
Local	The adjustable frequency drive uses [Hand On] control or reference values from the LCP.

Table 7.2 Status Message Reference Site

	Operation Status
AC Brake	AC Brake was selected in 2-10 Brake Function. The AC brake overmagnetizes the motor to achieve a controlled slow-down.
AMA finish OK	Automatic motor adaptation (AMA) was carried out successfully.
AMA ready	AMA is ready to start. Press [Hand On] to start.
AMA running	AMA process is in progress.
Braking	The brake chopper is in operation. Generative energy is absorbed by the brake resistor.
Braking max.	The brake chopper is in operation. The power limit for the brake resistor defined in 2-12 Brake Power Limit (kW) has been reached.
Coast	<ul style="list-style-type: none"> <li>Coast inverse was selected as a function for a digital input (parameter group 5-1* Digital Inputs). The corresponding terminal is not connected.</li> <li>Coast activated by serial communication</li> </ul>

	Operation Status
Ctrl. Ramp-down	Control Ramp-down was selected in <i>14-10 Mains Failure</i> . <ul style="list-style-type: none"> <li>The AC line voltage is below the value set in <i>14-11 Mains Voltage at Mains Fault</i> at line power fault.</li> <li>The adjustable frequency drive ramps down the motor using a controlled ramp-down.</li> </ul>
Current High	The adjustable frequency drive output current is above the limit set in <i>4-51 Warning Current High</i> .
Current Low	The adjustable frequency drive output current is below the limit set in <i>4-52 Warning Speed Low</i> .
DC Hold	DC hold is selected in <i>1-80 Function at Stop</i> and a stop command is active. The motor is held by a DC current set in <i>2-00 DC Hold/ Preheat Current</i> .
DC Stop	The motor is held with a DC current ( <i>2-01 DC Brake Current</i> ) for a specified time ( <i>2-02 DC Braking Time</i> ). <ul style="list-style-type: none"> <li>DC Brake is activated in <i>2-03 DC Brake Cut-in Speed [RPM]</i> and a Stop command is active.</li> <li>DC Brake (inverse) is selected as a function for a digital input (parameter group <i>5-1* Digital Inputs</i>). The corresponding terminal is not active.</li> <li>The DC Brake is activated via serial communication.</li> </ul>
Feedback high	The sum of all active feedback is above the feedback limit set in <i>4-57 Warning Feedback High</i> .
Feedback low	The sum of all active feedback is below the feedback limit set in <i>4-56 Warning Feedback Low</i> .
Freeze output	The remote reference is active, which holds the present speed. <ul style="list-style-type: none"> <li>Freeze output was selected as a function for a digital input (parameter group <i>5-1* Digital Inputs</i>). The corresponding terminal is active. Speed control is only possible via the terminal functions Speed Up and Slow.</li> <li>Hold ramp is activated via serial communication.</li> </ul>
Freeze output request	A freeze output command has been given, but until a run permissive signal is received, the motor remains stopped.

	Operation Status
Freeze ref.	<i>Freeze Reference</i> was chosen as a function for a digital input (parameter group <i>5-1* Digital Inputs</i> ). The corresponding terminal is active. The adjustable frequency drive saves the actual reference. Changing the reference is now only possible via terminal functions Speed Up and Slow.
Jog request	A jog command has been given, but until a run permissive signal is received via a digital input, the motor is stopped.
Jogging	The motor is running as programmed in <i>3-19 Jog Speed [RPM]</i> . <ul style="list-style-type: none"> <li><i>Jog</i> was selected as function for a digital input (parameter group <i>5-1* Digital Inputs</i>). The corresponding terminal (for example, Terminal 29) is active.</li> <li>The Jog function is activated via the serial communication.</li> <li>The Jog function was selected as a reaction for a monitoring function (for example, No signal). The monitoring function is active.</li> </ul>
Motor check	In <i>1-80 Function at Stop</i> , <i>Motor Check</i> was selected. A stop command is active. To ensure that a motor is connected to the adjustable frequency drive, a permanent test current is applied to the motor.
Over Voltage Control (OVC)	<i>Overvoltage</i> control was activated in <i>2-17 Overvoltage Control</i> . The connected motor is supplying the adjustable frequency drive with generative energy. Overvoltage control adjusts the V/Hz ratio to run the motor in controlled mode and to prevent the adjustable frequency drive from tripping.
PowerUnit Off	(For adjustable frequency drives with an external 24 V power supply installed only.) Line power supply to the adjustable frequency drive is removed, but the control card is supplied by the external 24 V.
Protection md	Protection mode is active. The unit has detected a critical status (an overcurrent or overvoltage). <ul style="list-style-type: none"> <li>To avoid tripping, switching frequency is reduced to 4 kHz.</li> <li>If possible, Protection mode ends after approximately 10 s</li> <li>Protection mode can be restricted in <i>14-26 Trip Delay at Inverter Fault</i></li> </ul>

	<b>Operation Status</b>
QStop	The motor is decelerating using <i>3-81 Quick Stop Ramp Time</i> . <ul style="list-style-type: none"> <li>Quick stop inverse was chosen as a function for a digital input (parameter group 5-1*). The corresponding terminal is not active.</li> <li>The quick stop function was activated via serial communication.</li> </ul>
Ramping	The motor is accelerating/decelerating using the active ramp-up/down. The reference, a limit value or a standstill is not yet reached.
Ref. high	The sum of all active references is above the reference limit set in <i>4-55 Warning Reference High</i> .
Ref. low	The sum of all active references is below the reference limit set in <i>4-54 Warning Reference Low</i> .
Run on ref.	The adjustable frequency drive is running in the reference range. The feedback value matches the setpoint value.
Run request	A start command has been given, but the motor is stopped until a run permissive signal is received via digital input.
Running	The adjustable frequency drive runs the motor.
Sleep Mode	The energy saving function is enabled. The motor has stopped, but will restart automatically when required.
Speed high	Motor speed is above the value set in <i>4-53 Warning Speed High</i> .
Speed low	Motor speed is below the value set in <i>4-52 Warning Speed Low</i> .
Standby	In Auto On Auto mode, the adjustable frequency drive starts the motor with a start signal from a digital input or serial communication.
Start delay	In <i>1-71 Start Delay</i> , a delay starting time was set. A start command is activated and the motor will start after the start delay time expires.
Start fwd/rev	Start forward and start reverse were selected as functions for two different digital inputs (parameter group 5-1* <i>Digital Inputs</i> ). The motor starts in forward or reverse depending on which corresponding terminal is activated.
Stop	The adjustable frequency drive has received a stop command from the LCP, digital input or serial communication.

	<b>Operation Status</b>
Trip	An alarm occurred and the motor is stopped. Once the cause of the alarm is cleared, the adjustable frequency drive can be reset manually by pressing [Reset] or remotely by control terminals or serial communication.
Trip lock	An alarm occurred and the motor is stopped. Once the cause of the alarm is cleared, power must be cycled to the adjustable frequency drive. The adjustable frequency drive can then be reset manually by pressing [Reset] or remotely by control terminals or serial communication.

**Table 7.3 Status Message Operation Status**



## 8 Warnings and Alarms

### 8.1 System Monitoring

The adjustable frequency drive monitors the condition of its input power, output, and motor factors as well as other system performance indicators. A warning or alarm may not necessarily indicate a problem internal to the adjustable frequency drive itself. In many cases, it indicates failure conditions from input voltage, motor load or temperature, external signals, or other areas monitored by the adjustable frequency drive's internal logic. Be sure to investigate those areas exterior to the adjustable frequency drive as indicated in the alarm or warning.

### 8.2 Warning and Alarm Types

#### Warnings

A warning is issued when an alarm condition is impending or when an abnormal operating condition is present and may result in the adjustable frequency drive issuing an alarm. A warning clears by itself when the abnormal condition is removed.

#### Alarms

##### Trip

An alarm is issued when the adjustable frequency drive is tripped, that is, the adjustable frequency drive suspends operation to prevent adjustable frequency drive or system damage. The motor will coast to a stop. The adjustable frequency drive logic will continue to operate and monitor the adjustable frequency drive status. After the fault condition is remedied, the adjustable frequency drive can be reset. It will then be ready to start operation again.

A trip can be reset in any of four ways

- Press [Reset] on the LCP
- Digital reset input command
- Serial communication reset input command
- Auto reset

An alarm that causes the adjustable frequency drive to trip-lock requires that input power is cycled. The motor will coast to a stop. The adjustable frequency drive logic will continue to operate and monitor the adjustable frequency drive status. Remove input power to the adjustable frequency drive and correct the cause of the fault, then restore power. This action puts the adjustable frequency drive into a trip condition as described above and may be reset in any of those four ways.

### 8.3 Warning and Alarm Displays

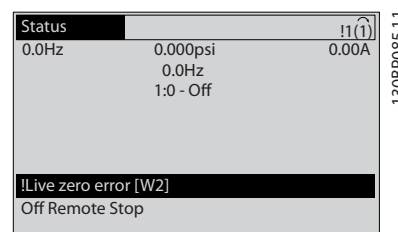

Figure 8.1 Warning Display

An alarm or trip lock alarm will flash on display along with the alarm number.

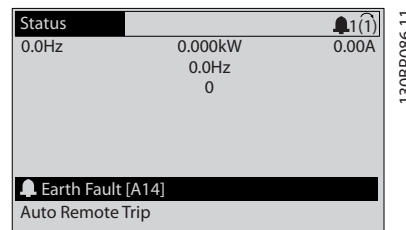

Figure 8.2 Alarm Display

In addition to the text and alarm code on the adjustable frequency drive LCP, there are three status indicator lights.

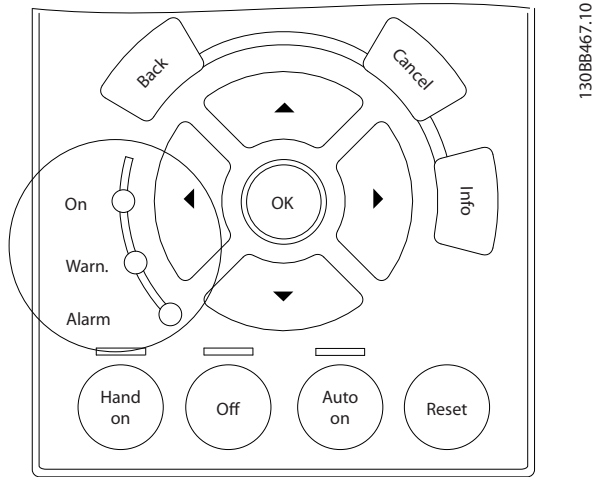

Figure 8.3 Status Indicator Lights

8

	Warning LED	Alarm LED
Warning	On	Off
Alarm	Off	On (Flashing)
Trip Lock	On	On (Flashing)

Table 8.1 Status Indicator Lights Explanations



## 8.4 Warning and Alarm Definitions

### CAUTION

Before applying power to the unit, inspect the entire installation as detailed in *Table 3.1*. Check mark those items when completed.

Inspect for	Description	<input checked="" type="checkbox"/>
Auxiliary equipment	<ul style="list-style-type: none"> <li>Look for auxiliary equipment, switches, disconnects, or input fuses/circuit breakers that may reside on the input power side of the adjustable frequency drive or output side to the motor. Ensure that they are ready for full speed operation.</li> <li>Check function and installation of any sensors used for feedback to the adjustable frequency drive</li> <li>Remove power factor correction caps on motor(s), if present</li> </ul>	
Cable routing	<ul style="list-style-type: none"> <li>Ensure that input power, motor wiring, and control wiring are separated or in three separate metallic conduits for high frequency noise isolation</li> </ul>	
Control wiring	<ul style="list-style-type: none"> <li>Check for broken or damaged wires and loose connections.</li> <li>Check that control wiring is isolated from power and motor wiring for noise immunity.</li> <li>Check the voltage source of the signals, if necessary.</li> <li>The use of shielded cable or twisted pair is recommended. Ensure that the shield is terminated correctly</li> </ul>	
Cooling clearance	<ul style="list-style-type: none"> <li>Make sure that the top and bottom clearance is adequate to ensure proper airflow for cooling.</li> </ul>	
EMC considerations	<ul style="list-style-type: none"> <li>Check for proper installation regarding electromagnetic compatibility.</li> </ul>	
Environmental considerations	<ul style="list-style-type: none"> <li>See equipment label for the maximum ambient operating temperature limits</li> <li>Humidity levels must be 5%–95% non-condensing.</li> </ul>	
Fusing and circuit breakers	<ul style="list-style-type: none"> <li>Check for proper fusing or circuit breakers.</li> <li>Check that all fuses are inserted firmly and in operational condition and that all circuit breakers are in the open position</li> </ul>	
Grounding	<ul style="list-style-type: none"> <li>The unit requires a ground wire from its chassis to the building ground</li> <li>Check for good ground connections that are tight and free of oxidation</li> <li>Grounding to conduit or mounting the back panel to a metal surface is not a suitable ground</li> </ul>	
Input and output power wiring	<ul style="list-style-type: none"> <li>Check for loose connections.</li> <li>Check that motor and line power are in separate conduits or separated shielded cables</li> </ul>	
Panel interior	<ul style="list-style-type: none"> <li>Make sure that the unit interior is free of dirt, metal chips, moisture, and corrosion.</li> </ul>	
Switches	<ul style="list-style-type: none"> <li>Ensure that all switch and disconnect settings are in the proper positions</li> </ul>	
Vibration	<ul style="list-style-type: none"> <li>Check that the unit is mounted solidly or that shock mounts are used, as necessary.</li> <li>Check for an unusual amount of vibration</li> </ul>	

Table 8.2 Start-up Check List



## 9 Basic Troubleshooting

### 9.1 Start-up and Operation

Symptom	Possible cause	Test	Solution
Display dark/No function	Missing input power	See <i>Table 3.1</i>	Check the input power source
	Missing or open fuses or circuit breaker tripped	See open fuses and tripped circuit breaker in this table for possible causes.	Follow the recommendations provided
	No power to the LCP	Check the LCP cable for proper connection or damage.	Replace the faulty LCP or connection cable.
	Shortcut on control voltage (terminal 12 or 50) or at control terminals	Check the 24 V control voltage supply for terminals 12/13 to 20-39 or 10 V supply for terminals 50 to 55.	Wire the terminals properly.
	Wrong LCP (LCP from VLT® 2800 or 5000/6000/8000/ FCD or FCM)		Use only LCP 101 (P/N 130B1124) or LCP 102 (P/N 130B1107).
	Wrong contrast setting		Press [Status] + [▲]/[▼] to adjust the contrast
	Display (LCP) is defective	Test using a different LCP	Replace the faulty LCP or connection cable.
	Internal voltage supply fault or SMPS is defective		Contact supplier
Intermittent display	Overloaded power supply (SMPS) due to improper control wiring or a fault within the adjustable frequency drive.	To rule out a problem in the control wiring, disconnect all control wiring by removing the terminal blocks.	If the display stays lit, then the problem is in the control wiring. Check the wiring for shorts or incorrect connections. If the display continues to cut out, follow the procedure for display dark.

Symptom	Possible cause	Test	Solution
Motor not running	Service switch open or missing motor connection	Check if the motor is connected and the connection is not interrupted (by a service switch or other device).	Connect the motor and check the service switch.
	No line power with 24 V DC option card	If the display is functioning but no output, check that line power is applied to the adjustable frequency drive.	Apply line power to run the unit.
	LCP Stop	Check if [Off] has been pressed.	Press [Auto On] or [Hand On] (depending on operation mode) to run the motor.
	Missing start signal (Standby)	Check 5-10 <i>Terminal 18 Digital Input</i> for correct setting for terminal 18 (use default setting)	Apply a valid start signal to start the motor.
	Motor coast signal active (Coasting)	Check 5-12 <i>Coast inv.</i> for correct setting for terminal 27 (use default setting).	Apply 24 V on terminal 27 or program this terminal to <i>No operation</i> .
	Wrong reference signal source	Check reference signal: Local, remote or bus reference? Preset reference active? Terminal connection correct? Scaling of terminals correct? Reference signal available?	Program correct settings. Check 3-13 <i>Reference Site</i> . Set preset reference active in parameter group 3-1* <i>References</i> . Check for correct wiring. Check scaling of terminals. Check reference signal.
Motor running in wrong direction	Motor rotation limit	Check that 4-10 <i>Motor Speed Direction</i> is programmed correctly.	Program correct settings.
	Active reversing signal	Check if a reversing command is programmed for the terminal in parameter group 5-1* <i>Digital inputs</i> .	Deactivate reversing signal.
	Wrong motor phase connection		See in this manual.
Motor is not reaching maximum speed.	Frequency limits set wrong.	Check output limits in 4-13 <i>Motor Speed High Limit [RPM]</i> , 4-14 <i>Motor Speed High Limit [Hz]</i> and 4-19 <i>Max Output Frequency</i> .	Program correct limits.
	Reference input signal not scaled correctly	Check reference input signal scaling in 6-0* <i>Analog I/O Mode</i> and parameter group 3-1* <i>References</i> . Reference limits in parameter group 3-0* <i>Reference Limit</i> .	Program correct settings.
Motor speed unstable	Possible incorrect parameter settings	Check the settings of all motor parameters, including all motor compensation settings. For closed-loop operation, check PID settings.	Check settings in parameter group 1-6* <i>Analog I/O mode</i> . For closed-loop operation, check settings in parameter group 20-0* <i>Feedback</i> .
Motor runs rough	Possible over-magnetization	Check for incorrect motor settings in all motor parameters.	Check motor settings in parameter groups 1-2* <i>Motor Data</i> , 1-3* <i>Adv Motor Data</i> , and 1-5* <i>Load Indep. Setting</i> .
Motor will not brake.	Possible incorrect settings in the brake parameters. Possible too short ramp down times.	Check brake parameters. Check ramp time settings.	Check parameter group 2-0* <i>DC Brake</i> and 3-0* <i>Reference Limits</i> .

Symptom	Possible cause	Test	Solution
Open power fuses or circuit breaker trip.	Phase to phase short	Motor or panel has a short phase to phase. Check motor and panel phase for shorts.	Eliminate any shorts detected.
	Motor overload	Motor is overloaded for the application.	Perform start-up test and verify motor current is within specifications. If motor current is exceeding nameplate full load current, motor may run only with reduced load. Review the specifications for the application.
	Loose connections	Perform pre-startup check for loose connections.	Tighten loose connections.
Line power current imbalance greater than 3%	Problem with line power (See <i>Alarm 4 Line phase loss</i> description).	Rotate input power leads into the adjustable frequency drive one position: A to B, B to C, C to A.	If imbalanced leg follows the wire, it is a power problem. Check line power supply.
	Problem with the adjustable frequency drive	Rotate input power leads into the adjustable frequency drive one position: A to B, B to C, C to A.	If imbalance leg stays on same input terminal, it is a problem with the unit. Contact the supplier.
Motor current imbalance greater than 3%	Problem with motor or motor wiring	Rotate output motor leads one position: U to V, V to W, W to U.	If imbalanced leg follows the wire, the problem is in the motor or motor wiring. Check motor and motor wiring.
	Problem with the adjustable frequency drives	Rotate output motor leads one position: U to V, V to W, W to U.	If imbalance leg stays on same output terminal, it is a problem with the unit. Contact the supplier.
Acoustic noise or vibration	Resonances	Bypass critical frequencies by using parameters in parameter group 4-6* <i>Speed Bypass</i> .	Check if noise and/or vibration have been reduced to an acceptable limit.
		Turn off over-modulation in 14-03 <i>Overmodulation</i>	
		Change switching pattern and frequency in parameter group 14-0* <i>Inverter Switching</i> .	
		Increase Resonance Dampening in 1-64 <i>Resonance Dampening</i>	

Table 9.1 Troubleshooting



## 10 Specifications

### 10.1 Power-dependent Specifications

#### 10.1.1 Line Power Supply 1 x 200–240 V AC

Line Power Supply 1 x 200–240 V AC - Normal overload 110% for 1 minute									
	P1K1	P1K5	P2K2	P3K0	P3K7	P5K5	P7K5	P15K	P22K
Adjustable frequency drive	1.1	1.5	2.2	3.0	3.7	5.5	7.5	15	22
Typical Shaft Output [kW]	1.5	2.0	2.9	4.0	4.9	7.5	10	20	30
Typical Shaft Output [HP] at 240 V	A3	-	-	-	-	-	-	-	-
IP20/Chassis	-	B1	B1	B1	B1	B1	B2	C1	C2
IP21/NEMA 1	A5	B1	B1	B1	B1	B1	B2	C1	C2
IP55/NEMA 12	A5	B1	B1	B1	B1	B1	B2	C1	C2
IP66	A5	B1	B1	B1	B1	B1	B2	C1	C2
<b>Output current</b>									
Continuous (3 x 200–240 V) [A]	6.6	7.5	10.6	12.5	16.7	24.2	30.8	59.4	88
Intermittent(3 x 200–240 V) [A]	7.3	8.3	11.7	13.8	18.4	26.6	33.4	65.3	96.8
Continuous kVA (208 V AC) [kVA]						5.00	6.40	12.27	18.30
<b>Max. input current</b>									
Continuous (1 x 200–240 V) [A]	12.5	15	20.5	24	32	46	59	111	172
Intermittent (1 x 200–240 V) [A]	13.8	16.5	22.6	26.4	35.2	50.6	64.9	122.1	189.2
Max. pre-fuses <sup>1)</sup> [A]	20	30	40	40	60	80	100	150	200
<b>Additional specifications</b>									
Estimated power loss at rated max. load [W] <sup>4)</sup>	44	30	44	60	74	110	150	300	440
Max. cable size (line power, motor, brake) [mm <sup>2</sup> ]/(AWG) <sup>2)</sup>	[0.2–4]/(4–10)					[10]/(7)	[35]/(2)	[50]/(1)/0	[95]/(4)/0
Weight enclosure IP20 (lb [kg])	10.8 [4.9]	-	-	-	-	-	-	-	-
Weight enclosure IP21 (lb [kg])	-	50.71 [23]	50.71 [23]	50.71 [23]	50.71 [23]	50.71 [23]	59.53 [27]	99.21 [45]	143.3 [65]
Weight enclosure IP55 (lb [kg])	-	50.71 [23]	50.71 [23]	50.71 [23]	50.71 [23]	50.71 [23]	59.53 [27]	99.21 [45]	143.3 [65]
Weight enclosure IP66 (lb [kg])	-	50.71 [23]	50.71 [23]	50.71 [23]	50.71 [23]	50.71 [23]	59.53 [27]	99.21 [45]	143.3 [65]
Efficiency <sup>3)</sup>	0.968	0.98	0.98	0.98	0.98	0.98	0.98	0.98	0.98

Table 10.1 Line Power Supply 1 x 200–240 V AC - Normal Overload 110% for 1 Minute

10.1.2 Line Power Supply 3 x 200–240 V AC

Line Power Supply 3 x 200–240 V AC - Normal overload 110% for 1 minute									
Adjustable frequency drive	PK25	PK37	PK55	PK75	P1K1	P1K5	P2K2	P3K0	P3K7
Typical Shaft Output [kW]	0.25	0.37	0.55	0.75	1.1	1.5	2.2	3	3.7
Typical Shaft Output [HP] at 208 V	0.25	0.37	0.55	0.75	1.5	2.0	2.9	4.0	4.9
IP20/NEMA Chassis	A2	A2	A2	A2	A2	A2	A2	A3	A3
IP21/NEMA 1	A2	A2	A2	A2	A2	A2	A2	A3	A3
IP55/NEMA 12	A5	A5	A5	A5	A5	A5	A5	A5	A5
IP66	A5	A5	A5	A5	A5	A5	A5	A5	A5
<b>Output current</b>									
Continuous (3 x 200–240 V) [A]	1.8	2.4	3.5	4.6	6.6	7.5	10.6	12.5	16.7
Intermittent (3 x 200–240 V) [A]	1.98	2.64	3.85	5.06	7.26	8.3	11.7	13.8	18.4
Continuous kVA (208 V AC) [kVA]	0.65	0.86	1.26	1.66	2.38	2.70	3.82	4.50	6.00
<b>Max. input current</b>									
Continuous (3 x 200–240 V) [A]	1.6	2.2	3.2	4.1	5.9	6.8	9.5	11.3	15.0
Intermittent (3 x 200–240 V) [A]	1.7	2.42	3.52	4.51	6.5	7.5	10.5	12.4	16.5
Max. pre-fuses <sup>1)</sup> [A]	10	10	10	10	20	20	20	32	32
<b>Additional specifications</b>									
Estimated power loss at rated max. load [W] <sup>4)</sup>	21	29	42	54	63	82	116	155	185
Max. cable size (line power, motor, brake) [mm <sup>2</sup> ]/(AWG) <sup>2)</sup>	[0.2–4]/(4–10)								
Weight enclosure IP20 (lb [kg])	10.8 [4.9]	10.8 [4.9]	10.8 [4.9]	10.8 [4.9]	10.8 [4.9]	10.8 [4.9]	10.8 [4.9]	14.55 [6.6]	14.55 [6.6]
Weight enclosure IP21 (lb [kg])	12.13 [5.5]	12.13 [5.5]	12.13 [5.5]	12.13 [5.5]	12.13 [5.5]	12.13 [5.5]	12.13 [5.5]	16.54 [7.5]	16.54 [7.5]
Weight enclosure IP55 (lb [kg])	29.76 [13.5]	29.76 [13.5]	29.76 [13.5]	29.76 [13.5]	29.76 [13.5]	29.76 [13.5]	29.76 [13.5]	29.76 [13.5]	29.76 [13.5]
Weight enclosure IP66 (lb [kg])	29.76 [13.5]	29.76 [13.5]	29.76 [13.5]	29.76 [13.5]	29.76 [13.5]	29.76 [13.5]	29.76 [13.5]	29.76 [13.5]	29.76 [13.5]
Efficiency <sup>3)</sup>	0.94	0.94	0.95	0.95	0.96	0.96	0.96	0.96	0.96

Table 10.2 Line Power Supply 3 x 200–240 V AC - Normal Overload 110% for 1 Minute



**Specifications** **VLT® AQUA Drive**  
**Instruction Manual**

<b>Line Power Supply 3 x 200–240 V AC - Normal overload 110% for 1 minute</b>									
Adjustable frequency drive	<b>P5K5</b>	<b>P7K5</b>	<b>P11K</b>	<b>P15K</b>	<b>P18K</b>	<b>P22K</b>	<b>P30K</b>	<b>P37K</b>	<b>P45K</b>
Typical Shaft Output [kW]	<b>5.5</b>	<b>7.5</b>	<b>11</b>	<b>15</b>	<b>18.5</b>	<b>22</b>	<b>30</b>	<b>37</b>	<b>45</b>
Typical Shaft Output [HP] at 208 V	7.5	10	15	20	25	30	40	50	60
IP20/NEMA Chassis*	B3	B3	B3	B4	B4	C3	C3	C4	C4
IP21/NEMA 1	B1	B1	B1	B2	C1	C1	C1	C2	C2
IP55/NEMA 12	B1	B1	B1	B2	C1	C1	C1	C2	C2
IP66	B1	B1	B1	B2	C1	C1	C1	C2	C2
<b>Output current</b>									
Continuous (3 x 200–240 V) [A]	24.2	30.8	46.2	59.4	74.8	88.0	115	143	170
Intermittent (3 x 200–240 V) [A]	26.6	33.9	50.8	65.3	82.3	96.8	127	157	187
Continuous kVA (208 V AC) [kVA]	8.7	11.1	16.6	21.4	26.9	31.7	41.4	51.5	61.2
<b>Max. input current</b>									
Continuous (3 x 200–240 V) [A]	22.0	28.0	42.0	54.0	68.0	80.0	104.0	130.0	154.0
Intermittent (3 x 200–240 V) [A]	24.2	30.8	46.2	59.4	74.8	88.0	114.0	143.0	169.0
Max. pre-fuses <sup>1)</sup> [A]	63	63	63	80	125	125	160	200	250
<b>Additional specifications</b>									
Estimated power loss at rated max. load [W] <sup>4)</sup>	269	310	447	602	737	845	1140	1353	1636
Max. cable size (line power, motor, brake) [mm <sup>2</sup> ]/(AWG) <sup>2)</sup>	[10]/(7)		[35]/(2)	[50]/(1/0)			[95]/(4/0)	[120]/(250 MCM)	
Weight enclosure IP20 (lb [kg])	26.46 [12]	26.46 [12]	26.46 [12]	51.81 [23.5]	51.81 [23.5]	77.16 [35]	77.16 [35]	110.23 [50]	110.23 [50]
Weight enclosure IP21 (lb [kg])	50.71 [23]	50.71 [23]	50.71 [23]	59.53 [27]	99.21 [45]	99.21 [45]	143.3 [65]	143.3 [65]	143.3 [65]
Weight enclosure IP55 (lb [kg])	50.71 [23]	50.71 [23]	50.71 [23]	59.53 [27]	99.21 [45]	99.21 [45]	143.3 [65]	143.3 [65]	143.3 [65]
Weight enclosure IP66 (lb [kg])	50.71 [23]	50.71 [23]	50.71 [23]	59.53 [27]	99.21 [45]	99.21 [45]	143.3 [65]	143.3 [65]	143.3 [65]
Efficiency <sup>3)</sup>	0.96	0.96	0.96	0.96	0.96	0.97	0.97	0.97	0.97

**Table 10.3 Line Power Supply 3 x 200–240 V AC - Normal Overload 110% for 1 Minute**

\* B3+4 and C3+4 may be converted to IP21 using a conversion kit (contact Danfoss)

### 10.1.3 Line Power Supply 1 x 380–480 V AC

<b>Line Power Supply 1 x 380 V AC - Normal overload 110% for 1 minute</b>				
	<b>P7K5</b>	<b>P11K</b>	<b>P18K</b>	<b>P37K</b>
Adjustable frequency drive	<b>7.5</b>	<b>11</b>	<b>18.5</b>	<b>37</b>
Typical Shaft Output [kW]	<b>7.5</b>	<b>11</b>	<b>18.5</b>	<b>37</b>
Typical Shaft Output [HP] at 460 V	10	15	25	50
IP21/NEMA 1	B1	B2	C1	C2
IP55/NEMA 12	B1	B2	C1	C2
IP66	B1	B2	C1	C2
<b>Output current</b>				
Continuous (3 x 380–440 V) [A]	16	24	37.5	73
Intermittent (3 x 380–440 V) [A]	17.6	26.4	41.2	80.3
Continuous (3 x 441–480 V) [A]	14.5	21	34	65
Intermittent (3 x 441–480 V) [A]	15.4	23.1	37.4	71.5
Continuous kVA (400 V AC) [kVA]	11.0	16.6	26	50.6
Continuous kVA (460 V AC) [kVA]	11.6	16.7	27.1	51.8
<b>Max. input current</b>				
Continuous (1 x 380–440 V) [A]	33	48	78	151
Intermittent (1 x 380–440 V) [A]	36	53	85.8	166
Continuous (1 x 441–480 V) [A]	30	41	72	135
Intermittent (1 x 441–480 V) [A]	33	46	79.2	148
Max. pre-fuses <sup>1)</sup> [A]	63	80	160	250
<b>Additional specifications</b>				
Estimated power loss at rated max. load [W] <sup>4)</sup>	300	440	740	1480
Max. cable size (line power, motor, brake) [mm <sup>2</sup> ]/(AWG) <sup>2)</sup>	[10]/(7)	[35]/(2)	[50]/(1/0)	[120]/(4/0)
Weight enclosure IP21 (lb [kg])	50.71 [23]	59.53 [27]	99.21 [45]	143.3 [65]
Weight enclosure IP55 (lb [kg])	50.71 [23]	59.53 [27]	99.21 [45]	143.3 [65]
Weight enclosure IP66 (lb [kg])	50.71 [23]	59.53 [27]	99.21 [45]	143.3 [65]
Efficiency <sup>3)</sup>	0.96	0.96	0.96	0.96

Table 10.4 Line Power Supply 1 x 380 V AC - Normal Overload 110% for 1 Minute

**10.1.4 Line Power Supply 3 x 380–480 V AC**

<b>Line Power Supply 3 x 380–480 V AC - Normal overload 110% for 1 minute</b>										
Adjustable frequency drive	<b>PK37</b>	<b>PK55</b>	<b>PK75</b>	<b>P1K1</b>	<b>P1K5</b>	<b>P2K2</b>	<b>P3K0</b>	<b>P4K0</b>	<b>P5K5</b>	<b>P7K5</b>
Typical Shaft Output [kW]	<b>0.37</b>	<b>0.55</b>	<b>0.75</b>	<b>1.1</b>	<b>1.5</b>	<b>2.2</b>	<b>3</b>	<b>4</b>	<b>5.5</b>	<b>7.5</b>
Typical Shaft Output [HP] at 460 V	0.5	0.75	1.0	1.5	2.0	2.9	4.0	5.3	7.5	10
IP20/NEMA Chassis	A2	A2	A2	A2	A2	A2	A2	A2	A3	A3
IP21/NEMA 1										
IP55/NEMA 12	A5	A5	A5	A5	A5	A5	A5	A5	A5	A5
IP66	A5	A5	A5	A5	A5	A5	A5	A5	AA	A5
<b>Output current</b>										
Continuous (3 x 380–440 V) [A]	1.3	1.8	2.4	3	4.1	5.6	7.2	10	13	16
Intermittent (3 x 380–440 V) [A]	1.43	1.98	2.64	3.3	4.5	6.2	7.9	11	14.3	17.6
Continuous (3 x 441–480 V) [A]	1.2	1.6	2.1	2.7	3.4	4.8	6.3	8.2	11	14.5
Intermittent (3 x 441–480 V) [A]	1.32	1.76	2.31	3.0	3.7	5.3	6.9	9.0	12.1	15.4
Continuous kVA (400 V AC) [kVA]	0.9	1.3	1.7	2.1	2.8	3.9	5.0	6.9	9.0	11.0
Continuous kVA (460 V AC) [kVA]	0.9	1.3	1.7	2.4	2.7	3.8	5.0	6.5	8.8	11.6
<b>Max. input current</b>										
Continuous (3 x 380–440 V) [A]	1.2	1.6	2.2	2.7	3.7	5.0	6.5	9.0	11.7	14.4
Intermittent (3 x 380–440 V) [A]	1.32	1.76	2.42	3.0	4.1	5.5	7.2	9.9	12.9	15.8
Continuous (3 x 441–480 V) [A]	1.0	1.4	1.9	2.7	3.1	4.3	5.7	7.4	9.9	13.0
Intermittent (3 x 441–480 V) [A]	1.1	1.54	2.09	3.0	3.4	4.7	6.3	8.1	10.9	14.3
Max. pre-fuses <sup>1)</sup> [A]	10	10	10	10	10	20	20	20	30	30
<b>Additional specifications</b>										
Estimated power loss at rated max. load [W] <sup>4)</sup>	35	42	46	58	62	88	116	124	187	255
Max. cable size (line power, motor, brake) [mm <sup>2</sup> ]/(AWG) <sup>2)</sup>	[4]/(10)									
Weight enclosure IP20 (lb [kg])	10.36 [4.7]	10.36 [4.7]	10.58 [4.8]	10.58 [4.8]	10.8 [4.9]	10.8 [4.9]	10.8 [4.9]	10.8 [4.9]	14.55 [6.6]	14.55 [6.6]
Weight enclosure IP21 (lb [kg])										
Weight enclosure IP55 (lb [kg])	29.76 [13.5]	29.76 [13.5]	29.76 [13.5]	29.76 [13.5]	29.76 [13.5]	29.76 [13.5]	29.76 [13.5]	29.76 [13.5]	31.31 [14.2]	31.31 [14.2]
Weight enclosure IP66 (lb [kg])	29.76 [13.5]	29.76 [13.5]	29.76 [13.5]	29.76 [13.5]	29.76 [13.5]	29.76 [13.5]	29.76 [13.5]	29.76 [13.5]	31.31 [14.2]	31.31 [14.2]
Efficiency <sup>3)</sup>	0.93	0.95	0.96	0.96	0.97	0.97	0.97	0.97	0.97	0.97

**Table 10.5 Line Power Supply 3 x 380–480 V AC - Normal Overload 110% for 1 Minute**

**Specifications** **VLT® AQUA Drive**  
**Instruction Manual**

<b>Line Power Supply 3 x 380–480 V AC - Normal overload 110% for 1 minute</b>										
Adjustable frequency drive	<b>P11K</b>	<b>P15K</b>	<b>P18K</b>	<b>P22K</b>	<b>P30K</b>	<b>P37K</b>	<b>P45K</b>	<b>P55K</b>	<b>P75K</b>	<b>P90K</b>
Typical Shaft Output [kW]	<b>11</b>	<b>15</b>	<b>18.5</b>	<b>22</b>	<b>30</b>	<b>37</b>	<b>45</b>	<b>55</b>	<b>75</b>	<b>90</b>
Typical Shaft Output [HP] at 460 V	15	20	25	30	40	50	60	75	100	125
IP20/NEMA Chassis *	B3	B3	B3	B4	B4	B4	C3	C3	C4	C4
IP21/NEMA 1	B1	B1	B1	B2	B2	C1	C1	C1	C2	C2
IP55/NEMA 12	B1	B1	B1	B2	B2	C1	C1	C1	C2	C2
IP66	B1	B1	B1	B2	B2	C1	C1	C1	C2	C2
<b>Output current</b>										
Continuous (3 x 380–440 V) [A]	24	32	37.5	44	61	73	90	106	147	177
Intermittent (3 x 380–440 V) [A]	26.4	35.2	41.3	48.4	67.1	80.3	99	117	162	195
Continuous (3 x 441–480 V) [A]	21	27	34	40	52	65	80	105	130	160
Intermittent (3 x 441–480 V) [A]	23.1	29.7	37.4	44	61.6	71.5	88	116	143	176
Continuous kVA (400 V AC) [kVA]	16.6	22.2	26	30.5	42.3	50.6	62.4	73.4	102	123
Continuous kVA (460 V AC) [kVA]	16.7	21.5	27.1	31.9	41.4	51.8	63.7	83.7	104	128
<b>Max. input current</b>										
Continuous (3 x 380–440 V) [A]	22	29	34	40	55	66	82	96	133	161
Intermittent (3 x 380–440 V) [A]	24.2	31.9	37.4	44	60.5	72.6	90.2	106	146	177
Continuous (3 x 441–480 V) [A]	19	25	31	36	47	59	73	95	118	145
Intermittent (3 x 441–480 V) [A]	20.9	27.5	34.1	39.6	51.7	64.9	80.3	105	130	160
Max. pre-fuses <sup>1)</sup> [A]	63	63	63	63	80	100	125	160	250	250
<b>Additional specifications</b>										
Estimated power loss at rated max. load [W] <sup>4)</sup>	278	392	465	525	698	739	843	1083	1384	1474
Max. cable size (line power, motor, brake) [mm <sup>2</sup> ]/(AWG) <sup>2)</sup>	[10]/(7)		[35]/(2)		[50]/(1/0)			[120]/(4/0)	[120]/(4/0)	
Weight enclosure IP20 (lb [kg])	26.46 [12]	26.46 [12]	26.46 [12]	51.81 [23.5]	51.81 [23.5]	51.81 [23.5]	77.16 [35]	77.16 [35]	110.23 [50]	110.23 [50]
Weight enclosure IP21 (lb [kg])	50.71 [23]	50.71 [23]	50.71 [23]	59.53 [27]	59.53 [27]	99.21 [45]	99.21 [45]	99.21 [45]	143.3 [65]	143.3 [65]
Weight enclosure IP55 (lb [kg])	50.71 [23]	50.71 [23]	50.71 [23]	59.53 [27]	59.53 [27]	99.21 [45]	99.21 [45]	99.21 [45]	143.3 [65]	143.3 [65]
Weight enclosure IP66 (lb [kg])	50.71 [23]	50.71 [23]	50.71 [23]	59.53 [27]	59.53 [27]	99.21 [45]	99.21 [45]	99.21 [45]	143.3 [65]	143.3 [65]
Efficiency <sup>3)</sup>	0.98	0.98	0.98	0.98	0.98	0.98	0.98	0.98	0.98	0.99

**Table 10.6 Line Power Supply 3 x 380–480 V AC - Normal Overload 110% for 1 Minute**

\* B3+B4 and C3+C4 may be converted to IP21 using a conversion kit (contact Danfoss)

### 10.1.5 Line Power Supply 3 x 525–600 V AC

<b>Normal overload 110% for 1 minute</b>									
Adjustable frequency drive	<b>PK75</b>	<b>P1K1</b>	<b>P1K5</b>	<b>P2K2</b>	<b>P3K0</b>	<b>P4K0</b>	<b>P5K5</b>	<b>P7K5</b>	<b>P11K</b>
Typical Shaft Output [kW]	<b>0.75</b>	<b>1.1</b>	<b>1.5</b>	<b>2.2</b>	<b>3</b>	<b>4</b>	<b>5.5</b>	<b>7.5</b>	<b>11</b>
IP20/NEMA Chassis	A2	A2	A2	A2	A2	A2	A3	A3	B3
IP21/NEMA 1	A2	A2	A2	A2	A2	A2	A3	A3	B1
IP55/NEMA 12	A5	A5	A5	A5	A5	A5	A5	A5	B1
IP66	A5	A5	A5	A5	A5	A5	A5	A5	B1
<b>Output current</b>									
Continuous (3 x 525–550 V) [A]	1.8	2.6	2.9	4.1	5.2	6.4	9.5	11.5	19
Intermittent (3 x 525–550 V) [A]		2.9	3.2	4.5	5.7	7.0	10.5	12.7	21
Continuous (3 x 525–600 V) [A]	1.7	2.4	2.7	3.9	4.9	6.1	9.0	11.0	18
Intermittent (3 x 525–600 V) [A]		2.6	3.0	4.3	5.4	6.7	9.9	12.1	20
Continuous kVA (525 V AC) [kVA]	1.7	2.5	2.8	3.9	5.0	6.1	9.0	11.0	18.1
Continuous kVA (575 V AC) [kVA]	1.7	2.4	2.7	3.9	4.9	6.1	9.0	11.0	17.9
<b>Max. input current</b>									
Continuous (3 x 525–600 V) [A]	1.7	2.4	2.7	4.1	5.2	5.8	8.6	10.4	17.2
Intermittent (3 x 525–600 V) [A]		2.7	3.0	4.5	5.7	6.4	9.5	11.5	19
Max. pre-fuses <sup>1)</sup> [A]	10	10	10	20	20	20	32	32	40
<b>Additional specifications</b>									
Estimated power loss at rated max. load [W] <sup>4)</sup>	35	50	65	92	122	145	195	261	225
Max. cable size (line power, motor, brake) [mm <sup>2</sup> ]/(AWG) <sup>2)</sup>	[0.2–4]/(24–10)								[16]/(6)
Weight enclosure IP20 (lb [kg])	14.33 [6.5]	14.33 [6.5]	14.33 [6.5]	14.33 [6.5]	14.33 [6.5]	14.33 [6.5]	14.55 [6.6]	14.55 [6.6]	26.46 [12]
Efficiency <sup>4)</sup>	0.97	0.97	0.97	0.97	0.97	0.97	0.97	0.97	0.98

**Table 10.7 Line Power Supply 3 x 525–600 V AC**

<sup>1)</sup> For type of fuse, see 10.3.2 Fuse Tables

<sup>2)</sup> American Wire Gauge

<sup>3)</sup> Measured using 16 ft [5 m] shielded motor cables at rated load and rated frequency

<sup>4)</sup> The typical power loss is at normal load conditions and expected to be within ± 15% (tolerance relates to variety in voltage and cable conditions).

Values are based on a typical motor efficiency (eff2/eff3 border line). Lower efficiency motors will also add to the power loss in the adjustable frequency drive and vice versa.

If the switching frequency is raised from nominal, the power losses may rise significantly.

LCP and typical control card power consumption values are included. Further options and customer load may add up to 30 Watts to the losses. (Though typically only 4 W extra for a fully loaded control card or options for slot A or slot B, each).

Although measurements are made with state-of-the-art equipment, some measurement inaccuracy must be allowed for (± 5%).

<sup>5)</sup> Motor and line cable: 300 MCM/150 mm<sup>2</sup>

<b>Normal overload 110% for 1 minute</b>									
Adjustable frequency drive	<b>P15K</b>	<b>P18K</b>	<b>P22K</b>	<b>P30K</b>	<b>P37K</b>	<b>P45K</b>	<b>P55K</b>	<b>P75K</b>	<b>P90K</b>
Typical Shaft Output [kW]	<b>15</b>	<b>18.5</b>	<b>22</b>	<b>30</b>	<b>37</b>	<b>45</b>	<b>55</b>	<b>75</b>	<b>90</b>
IP20/NEMA Chassis	B3	B3	B4	B4	B4	C3	C3	C4	C4
IP21/NEMA 1	B1	B1	B2	B2	B2	C1	C1	C2	C2
IP55/NEMA 12	B1	B1	B2	B2	B2	C1	C1	C2	C2
IP66	B1	B1	B2	B2	B2	C1	C1	C2	C2
<b>Output current</b>									
Continuous (3 x 525–550 V) [A]	23	28	36	43	54	65	87	105	137
Intermittent (3 x 525–550 V) [A]	25	31	40	47	59	72	96	116	151
Continuous (3 x 525–600 V) [A]	22	27	34	41	52	62	83	100	131
Intermittent (3 x 525–600 V) [A]	24	30	37	45	57	68	91	110	144
Continuous kVA (525 V AC) [kVA]	21.9	26.7	34.3	41	51.4	61.9	82.9	100	130.5
Continuous kVA (575 V AC) [kVA]	21.9	26.9	33.9	40.8	51.8	61.7	82.7	99.6	130.5
<b>Max. input current</b>									
Continuous (3 x 525–600 V) [A]	20.9	25.4	32.7	39	49	59	78.9	95.3	124.3
Intermittent (3 x 525–600 V) [A]	23	28	36	43	54	65	87	105	137
Max. pre-fuses <sup>1)</sup> [A]	40	50	60	80	100	150	160	225	250
<b>Additional specifications</b>									
Estimated power loss at rated max. load [W] <sup>4)</sup>	285	329	460	560	740	860	890	1020	1130
Max. cable size (line power, motor, brake) [mm <sup>2</sup> ]/(AWG) <sup>2)</sup>			[35]/(2)			[50]/(1)		[95 <sup>5)</sup> ]/(3/0)	
Weight enclosure IP20 (lb [kg])	26.46 [12]	26.46 [12]	51.81 [23.5]	51.81 [23.5]	51.81 [23.5]	77.16 [35]	77.16 [35]	110.23 [50]	110.23 [50]
Efficiency <sup>4)</sup>	0.98	0.98	0.98	0.98	0.98	0.98	0.98	0.98	0.98

**Table 10.8 Line Power Supply 3 x 525–600 V AC**
<sup>1)</sup> For type of fuse, see 10.3.2 Fuse Tables

<sup>2)</sup> American Wire Gauge

<sup>3)</sup> Measured using 16 ft [5 m] shielded motor cables at rated load and rated frequency

<sup>4)</sup> The typical power loss is at normal load conditions and expected to be within ± 15% (tolerance relates to variety in voltage and cable conditions).

Values are based on a typical motor efficiency (eff2/eff3 border line).

Lower efficiency motors will also add to the power loss in the adjustable frequency drive and vice versa.

If the switching frequency is raised from nominal, the power losses may rise significantly.

LCP and typical control card power consumption values are included. Further options and customer load may add up to 30 Watts to the losses. (Though typically only 4 W extra for a fully loaded control card or options for slot A or slot B, each).

Although measurements are made with state-of-the-art equipment, some measurement inaccuracy must be allowed for (± 5%).

<sup>5)</sup> Motor and line cable: 300 MCM/150 mm<sup>2</sup>

### 10.1.6 Line Power Supply 3 x 525–690 V AC

Line Power Supply 3 x 525–690 V AC							
Adjustable Frequency Drive	P1K1	P1K5	P2K2	P3K0	P4K0	P5K5	P7K5
Typical Shaft Output [kW]	1.1	1.5	2.2	3	4	5.5	7.5
Enclosure IP20 (only)	A3	A3	A3	A3	A3	A3	A3
<b>Output current</b> High overload 110% for 1 min							
Continuous (3x525–550 V) [A]	2.1	2.7	3.9	4.9	6.1	9	11
Intermittent (3x525–550 V) [A]	2.3	3.0	4.3	5.4	6.7	9.9	12.1
Continuous kVA (3x551–690 V) [A]	1.6	2.2	3.2	4.5	5.5	7.5	10
Intermittent kVA (3x551–690 V) [A]	1.8	2.4	3.5	4.9	6.0	8.2	11
Continuous kVA 525 V AC	1.9	2.6	3.8	5.4	6.6	9	12
Continuous kVA 690 V AC	1.9	2.6	3.8	5.4	6.6	9	12
<b>Max. input current</b>							
Continuous (3x525–550 V) [A]	1.9	2.4	3.5	4.4	5.5	8	10
Intermittent (3x525–550 V) [A]	2.1	2.6	3.8	8.4	6.0	8.8	11
Continuous kVA (3x551–690 V) [A]	1.4	2.0	2.9	4.0	4.9	6.7	9
Intermittent kVA (3x551–690 V) [A]	1.5	2.2	3.2	4.4	5.4	7.4	9.9
<b>Additional specifications</b>							
IP20 max. cable cross-section <sup>5)</sup> (line power, motor, brake and load sharing) [mm <sup>2</sup> ]/(AWG)	[0.2–4]/(24–10)						
Estimated power loss at rated max. load [W] <sup>4)</sup>	44	60	88	120	160	220	300
Weight, enclosure IP20 (lbs [kg])	14.55 [6.6]	14.55 [6.6]	14.55 [6.6]	14.55 [6.6]	14.55 [6.6]	14.55 [6.6]	14.55 [6.6]
Efficiency <sup>4)</sup>	0.96	0.96	0.96	0.96	0.96	0.96	0.96

Table 10.9 Line Power Supply 3 x 525–690 V AC IP20

**Specifications**

**VLT® AQUA Drive  
Instruction Manual**

Normal overload 110% for 1 minute										
Adjustable frequency drive Typical Shaft Output [kW]	P11K 11	P15K 15	P18K 18.5	P22K 22	P30K 30	P37K 37	P45K 45	P55K 55	P75K 75	P90K 90
Typical Shaft Output [HP] at 575 V	10	16.4	20.1	24	33	40	50	60	75	100
IP21/NEMA 1	B2	B2	B2	B2	B2	C2	C2	C2	C2	C2
IP55/NEMA 12	B2	B2	B2	B2	B2	C2	C2	C2	C2	C2
Output current										
Continuous (3 x 525–550 V) [A]	14	19	23	28	36	43	54	65	87	105
Intermittent (3 x 525–550 V) [A]	15.4	20.9	25.3	30.8	39.6	47.3	59.4	71.5	95.7	115.5
Continuous (3 x 551–690 V) [A]	13	18	22	27	34	41	52	62	83	100
Intermittent (3 x 551–690 V) [A]	14.3	19.8	24.2	29.7	37.4	45.1	57.2	68.2	91.3	110
Continuous kVA (550 V AC) [kVA]	13.3	18.1	21.9	26.7	34.3	41	51.4	61.9	82.9	100
Continuous kVA (575 V AC) [kVA]	12.9	17.9	21.9	26.9	33.8	40.8	51.8	61.7	82.7	99.6
Continuous kVA (690 V AC) [kVA]	15.5	21.5	26.3	32.3	40.6	49	62.1	74.1	99.2	119.5
Max. input current										
Continuous (3 x 525–690 V) [A]	15	19.5	24	29	36	49	59	71	87	99
Intermittent (3 x 525–690 V) [A]	16.5	21.5	26.4	31.9	39.6	53.9	64.9	78.1	95.7	108.9
Max. pre-fuses <sup>1)</sup> [A]	63	63	63	63	80	100	125	160	160	160
Additional specifications										
Estimated power loss at rated max. load [W] <sup>4)</sup>	201	285	335	375	430	592	720	880	1200	1440
Max. cable size (line power, motor, brake) [mm <sup>2</sup> ]/(AWG) <sup>2)</sup>	[35]/(1/0)				[95]/(4/0)					
Weight IP21 (lbs [kg])	59.53 [27]	59.53 [27]	59.53 [27]	59.53 [27]	59.53 [27]	143.3 [65]	143.3 [65]	143.3 [65]	143.3 [65]	143.3 [65]
Weight IP55 (lbs [kg])	59.53 [27]	59.53 [27]	59.53 [27]	59.53 [27]	59.53 [27]	143.3 [65]	143.3 [65]	143.3 [65]	143.3 [65]	143.3 [65]
Efficiency <sup>4)</sup>	0.98	0.98	0.98	0.98	0.98	0.98	0.98	0.98	0.98	0.98

**Table 10.10 Line Power Supply 3 x 525–690 V AC IP21-IP55/NEMA 1-NEMA 12**



<b>Normal overload 110% for 1 minute</b>		
Adjustable frequency drive	<b>P45K</b>	<b>P55K</b>
Typical Shaft Output [kW]	<b>45</b>	<b>55</b>
Typical Shaft Output [HP] at 575 V	60	75
IP20/Chassis	C3	C3
Output current		
Continuous (3 x 525–550 V) [A]	54	65
Intermittent (3 x 525–550 V) [A]	59.4	71.5
Continuous (3 x 551–690 V) [A]	52	62
Intermittent (3 x 551–690 V) [A]	57.2	68.2
Continuous kVA (550 V AC) [kVA]	51.4	62
Continuous kVA (575 V AC) [kVA]	62.2	74.1
Continuous kVA (690 V AC) [kVA]	62.2	74.1
Max. input current		
Continuous (3 x 525–550 V) [A]	52	63
Intermittent (3 x 525–550 V) [A]	57.2	69.3
Continuous (3 x 551–690 V) [A]	50	60
Intermittent (3 x 551–690 V) [A]	55	66
Max. pre-fuses <sup>1)</sup> [A]	100	125
Additional specifications		
Estimated power loss at rated max. load [W] <sup>4)</sup>	592	720
Max. cable size (line power, motor, brake) [mm <sup>2</sup> ]/(AWG) <sup>2)</sup>	50 (1)	
Weight IP20 (lbs [kg])	77.16 [35]	77.16 [35]
Efficiency <sup>4)</sup>	0.98	0.98

**Table 10.11 Line Power Supply 3 x 525–690 V IP20**

<sup>1)</sup> For type of fuse, see 10.3.2 Fuse Tables

<sup>2)</sup> American Wire Gauge

<sup>3)</sup> Measured using 16 ft [5 m] shielded motor cables at rated load and rated frequency

<sup>4)</sup> The typical power loss is at normal load conditions and expected to be within  $\pm 15\%$  (tolerance relates to variety in voltage and cable conditions).

Values are based on a typical motor efficiency (eff2/eff3 border line). Lower efficiency motors will also add to the power loss in the adjustable frequency drive and vice versa.

If the switching frequency is raised from nominal, the power losses may rise significantly.

LCP and typical control card power consumption values are included. Further options and customer load may add up to 30 W to the losses. (Though typically only 4 W extra for a fully loaded control card or options for slot A or slot B, each).

Although measurements are made with state of the art equipment, some measurement inaccuracy must be allowed for ( $\pm 5\%$ ).

<sup>5)</sup> Motor and line cable: 300 MCM/150 mm<sup>2</sup>

## 10.2 General Technical Data

### Protection and Features

- Electronic thermal motor protection against overload.
- Temperature monitoring of the heatsink ensures that the adjustable frequency drive trips if the temperature reaches 203 °F  $\pm$  10 °F [95 °C  $\pm$  5 °C]. An overload temperature cannot be reset until the temperature of the heatsink is below 158 °F  $\pm$  10 °F [70 °C  $\pm$  5 °C] (Guideline - these temperatures may vary for different power sizes, enclosures etc.). VLT® AQUA Drive has an auto derating function to avoid its heatsink reaching 203 °F [95 °C].
- The frequency converter is protected against short circuits on motor terminals U, V, W.
- If a line phase is missing, the adjustable frequency drive trips or issues a warning (depending on the load).
- Monitoring of the intermediate circuit voltage ensures that the adjustable frequency drive trips if the intermediate circuit voltage is too low or too high.
- The adjustable frequency drive is protected against ground faults on motor terminals U, V, W.

### Line power supply (L1, L2, L3)

Supply voltage	200–240 V $\pm$ 10%
Supply voltage	380–480 V $\pm$ 10%
Supply voltage	525–600 V $\pm$ 10%
Supply voltage	525–690 V $\pm$ 10%

#### AC line voltage low/line drop-out:

During low AC line voltage or a line drop-out, the adjustable frequency drive continues until the intermediate circuit voltage drops below the minimum stop level, which corresponds typically to 15% below the adjustable frequency drive's lowest rated supply voltage. Power-up and full torque cannot be expected at AC line voltage lower than 10% below the adjustable frequency drive's lowest rated supply voltage.

Supply frequency	50/60 Hz +4/-6%
------------------	-----------------

The adjustable frequency drive power supply is tested in accordance with IEC61000-4-28, 50 Hz +4/-6%.

Max. temporary imbalance between line phases	3.0% of rated supply voltage
True Power Factor ( $\lambda$ )	$\geq$ 0.9 nominal at rated load
Displacement Power Factor ( $\cos\phi$ ) near unity	(> 0.98)
Switching on input supply L1, L2, L3 (power-ups) $\leq$ enclosure type A	maximum 2 times/min.
Switching on input supply L1, L2, L3 (power-ups) $\geq$ enclosure type B, C	maximum 1 time/min.
Switching on input supply L1, L2, L3 (power-ups) $\geq$ enclosure type D, E, F	maximum 1 time/2 min.
Environment according to EN60664-1	overvoltage category III/pollution degree 2

The unit is suitable for use on a circuit capable of delivering not more than 100,000 RMS symmetrical Amperes, 240/480/600/690 V maximum.

### Motor output (U, V, W)

Output voltage	0–100% of supply voltage
Output frequency	0–590 Hz*
Switching on output	Unlimited
Ramp times	1–3600 s

\* Dependent on power size.

### Torque characteristics

Starting torque (Constant torque)	maximum 110% for 1 min.*
Starting torque	maximum 135% up to 0.5 s*
Overload torque (Constant torque)	maximum 110% for 1 min.*

\*Percentage relates to VLT AQUA Drive's nominal torque.

**Specifications** **VLT® AQUA Drive**  
**Instruction Manual**

Cable lengths and cross-sections

Max. motor cable length, shielded/armored	500 ft [150 m]
Max. motor cable length, unshielded/unarmored	1000 ft [300 m]
Max. cross-section to motor, line power, load sharing and brake *	
Maximum cross-section to control terminals, rigid wire	1.5 mm <sup>2</sup> /16 AWG (2 x 0.75 mm <sup>2</sup> )
Maximum cross-section to control terminals, flexible cable	0.0016 in <sup>2</sup> [1 mm <sup>2</sup> ]/18 AWG
Maximum cross-section to control terminals, cable with enclosed core	0.5 mm <sup>2</sup> /20 AWG
Minimum cross-section to control terminals	0.00039 in <sup>2</sup> [0.25 mm <sup>2</sup> ]

\* See Line Power Supply tables for more information!

Control card, RS-485 serial communication

Terminal number	68 (P,TX+, RX+), 69 (N,TX-, RX-)
Terminal number 61	Common for terminals 68 and 69

The RS-485 serial communication circuit is functionally seated from other central circuits and galvanically isolated from the supply voltage (PELV).

Analog inputs

Number of analog inputs	2
Terminal number	53, 54
Modes	Voltage or current
Mode select	Switch S201 and switch S202
Voltage mode	Switch S201/switch S202 = OFF (U)
Voltage level	0 to +10 V (scaleable)
Input resistance, R <sub>i</sub>	approx. 10 kΩ
Max. voltage	±20 V
Current mode	Switch S201/switch S202 = ON (I)
Current level	0/4 to 20 mA (scaleable)
Input resistance, R <sub>i</sub>	approx. 200 Ω
Max. current	30 mA
Resolution for analog inputs	10 bit (+ sign)
Accuracy of analog inputs	Max. error 0.5% of full scale
Bandwidth	200 Hz

The analog inputs are galvanically isolated from the supply voltage (PELV) and other high-voltage terminals.

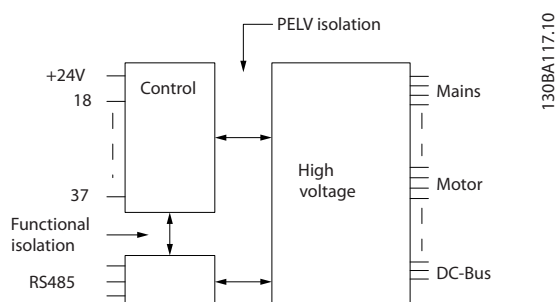

Figure 10.1 PELV Isolation of Analog Inputs

Analog output

Number of programmable analog outputs	1
Terminal number	42
Current range at analog output	0/4–20 mA
Max. resistor load to common at analog output	500 Ω
Accuracy on analog output	Max. error: 0.8% of full scale
Resolution on analog output	8 bit

The analog output is galvanically isolated from the supply voltage (PELV) and other high-voltage terminals.

**Specifications** **VLT® AQUA Drive**  
**Instruction Manual**

**Digital inputs**

Programmable digital inputs	4 (6)
Terminal number	18, 19, 27 <sup>1)</sup> , 29 <sup>1)</sup> , 32, 33,
Logic	PNP or NPN
Voltage level	0–24 V DC
Voltage level, logic '0' PNP	<5 V DC
Voltage level, logic '1' PNP	>10 V DC
Voltage level, logic '0' NPN	>19 V DC
Voltage level, logic '1' NPN	<14 V DC
Maximum voltage on input	28 V DC
Input resistance, R <sub>i</sub>	approx. 4 kΩ

All digital inputs are galvanically isolated from the supply voltage (PELV) and other high-voltage terminals.

1) Terminals 27 and 29 can also be programmed as output.

**Digital output**

Programmable digital/pulse outputs	2
Terminal number	27, 29 <sup>1)</sup>
Voltage level at digital/frequency output	0–24 V
Max. output current (sink or source)	40 mA
Max. load at frequency output	1 kΩ
Max. capacitive load at frequency output	10 nF
Minimum output frequency at frequency output	0 Hz
Maximum output frequency at frequency output	32 kHz
Accuracy of frequency output	Max. error: 0.1% of full scale
Resolution of frequency outputs	12 bit

1) Terminal 27 and 29 can also be programmed as input.

The digital output is galvanically isolated from the supply voltage (PELV) and other high-voltage terminals.

10

**Pulse inputs**

Programmable pulse inputs	2
Terminal number pulse	29, 33
Max. frequency at terminal, 29, 33	110 kHz (push-pull driven)
Max. frequency at terminal, 29, 33	5 kHz (open collector)
Min. frequency at terminal 29, 33	4 Hz
Voltage level	see 10.2.1
Maximum voltage on input	28 V DC
Input resistance, R <sub>i</sub>	approx. 4 kΩ
Pulse input accuracy (0.1–1 kHz)	Max. error: 0.1% of full scale
Control card, 24 V DC output	
Terminal number	12, 13
Max. load	200 mA

The 24 V DC supply is galvanically isolated from the supply voltage (PELV), but has the same potential as the analog and digital inputs and outputs.

**Relay outputs**

Programmable relay outputs	2
<b>Relay 01 Terminal number</b>	1-3 (break), 1-2 (make)
Max. terminal load (AC-1) <sup>1)</sup> on 1-3 (NC), 1-2 (NO) (Resistive load)	240 V AC, 2 A
Max. terminal load (AC-15) <sup>1)</sup> (Inductive load @ cosφ 0.4)	240 V AC, 0.2 A
Max. terminal load (DC-1) <sup>1)</sup> on 1-2 (NO), 1-3 (NC) (Resistive load)	60 V DC, 1 A
Max. terminal load (DC-13) <sup>1)</sup> (Inductive load)	24 V DC, 0.1 A
<b>Relay 02 Terminal number</b>	4-6 (break), 4-5 (make)
Max. terminal load (AC-1) <sup>1)</sup> on 4-5 (NO) (Resistive load) <sup>2)3)</sup>	400 V AC, 2 A

**Specifications** **VLT® AQUA Drive**  
**Instruction Manual**

Max. terminal load (AC-15) <sup>1)</sup> on 4-5 (NO) (Inductive load @ cosφ 0.4)	240 V AC, 0.2 A
Max. terminal load (DC-1) <sup>1)</sup> on 4-5 (NO) (Resistive load)	80 V DC, 2 A
Max. terminal load (DC-13) <sup>1)</sup> on 4-5 (NO) (Inductive load)	24 V DC, 0.1 A
Max. terminal load (AC-1) <sup>1)</sup> on 4-6 (NC) (Resistive load)	240 V AC, 2 A
Max. terminal load (AC-15) <sup>1)</sup> on 4-6 (NC) (Inductive load @ cosφ 0.4)	240 V AC, 0.2 A
Max. terminal load (DC-1) <sup>1)</sup> on 4-6 (NC) (Resistive load)	50 V DC, 2 A
Max. terminal load (DC-13) <sup>1)</sup> on 4-6 (NC) (Inductive load)	24 V DC, 0.1 A
Min. terminal load on 1-3 (NC), 1-2 (NO), 4-6 (NC), 4-5 (NO)	24 V DC 10 mA, 24 V AC 20 mA
Environment according to EN 60664-1	overvoltage category III/pollution degree 2

1) IEC 60947 parts 4 and 5

The relay contacts are galvanically isolated from the rest of the circuit by reinforced isolation (PELV).

2) Overvoltage Category II

3) UL applications 300 V AC 2 A

Control card, 10 V DC output

Terminal number	50
Output voltage	10.5 V ±0.5 V
Max. load	25 mA

The 10 V DC supply is galvanically isolated from the supply voltage (PELV) and other high-voltage terminals.

Control characteristics

Resolution of output frequency at 0–1000 Hz	±0.003 Hz
System response time (terminals 18, 19, 27, 29, 32, 33)	≤ 2 ms
Speed control range (open-loop)	1:100 of synchronous speed
Speed accuracy (open-loop)	30-4,000 rpm: Maximum error of ±8 rpm

All control characteristics are based on a 4-pole asynchronous motor

Surroundings

Enclosure type A	IP20/Chassis, IP21 kit/Type 1, IP55/Type12, IP66
Enclosure type B1/B2	IP21/Type 1, IP55/Type12, IP66
Enclosure type B3/B4	IP20/Chassis
Enclosure type C1/C2	IP21/Type 1, IP55/Type 12, IP66
Enclosure type C3/C4	IP20/Chassis
Enclosure type D1/D2/E1	IP21/Type 1, IP54/Type12
Enclosure type D3/D4/E2	IP00/Chassis
Enclosure kit available ≤ enclosure type A	IP21/TYP E 1/IP4X top
Vibration test enclosure A/B/C	0.035 oz [1.0 g]
Vibration test enclosure D/E/F	0.024 oz [0.7 g]
Max. relative humidity	5%–95% (IEC 721-3-3; Class 3K3 (non-condensing) during operation
Aggressive environment (IEC 721-3-3), uncoated	class 3C2
Aggressive environment (IEC 721-3-3), coated	class 3C3
Test method according to IEC 60068-2-43 H2S (10 days)	
Ambient temperature	Max. 122 °F [50 °C]

Derating for high ambient temperature, see section on special conditions

Minimum ambient temperature during full-scale operation	32 °F [0 °C]
Minimum ambient temperature at reduced performance	14 °F [-10 °C]
Temperature during storage/transport	-13 to +149/158 °F [-25 to +65/70 °C]
Maximum altitude above sea level without derating	3300 ft [1000 m]
Maximum altitude above sea level with derating	10,000 ft [3000 m]

Derating for high altitude, see section on special conditions

EMC standards, Emission	EN 61800-3, EN 61000-6-3, EN 55011, IEC 61800-3
EMC standards, Immunity	EN 61800-3, EN 61000-6-1/2,

EN 61000-4-2, EN 61000-4-3, EN 61000-4-4, EN 61000-4-5, EN 61000-4-6

*See section on special conditions*

Control card performance

---

Scan interval	5 ms
---------------	------

Control card, USB serial communication

---

USB standard	1.1 (Full speed)
--------------	------------------

---

USB plug	USB type B "device" plug
----------	--------------------------

---

**⚠ CAUTION**

Connection to PC is carried out via a standard host/device USB cable.

The USB connection is galvanically isolated from the supply voltage (PELV) and other high-voltage terminals.

The USB connection is not galvanically isolated from ground protection. Only use an isolated laptop/PC as the connection to the USB connector on an VLT AQUA Drive or an isolated USB cable/drive.

## 10.3 Fuse Specifications

### 10.3.1 CE Compliance

Fuses or circuit breakers are mandatory to comply with IEC 60364. Danfoss recommend using a selection of the following.

The fuses below are suitable for use on a circuit capable of delivering 100,000 Arms (symmetrical) with the following voltage

- 240 V
- 480 V
- 600 V
- 690 V

depending on the drive voltage rating. With the proper fusing, the drive Short Circuit Current Rating (SCCR) is 100,000 Arms.

### 10.3.2 Fuse Tables

Enclosure	Power (hp [kW])	Recommended fuse size	Recommended Max. fuse	Recommended circuit breaker Moeller	Max trip level [A]
A1	-	gG-10	gG-25	PKZM0-16	16
A2	0.34–3 [0.25–2.2]	gG-10 (0.34–2 [0.25–1.5]) gG-16 (3 [2.2])	gG-25	PKZM0-25	25
A3	4–5 [3.0–3.7]	gG-16 (4 [3]) gG-20 (5 [3.7])	gG-32	PKZM0-25	25
A4	0.34–3 [0.25–2.2]	gG-10 (0.34–2 [0.25–1.5]) gG-16 (3 [2.2])	gG-32	PKZM0-25	25
A5	0.34–5 [0.25–3.7]	gG-10 (0.34–2 [0.25–1.5]) gG-16 (3–4 [2.2–3]) gG-20 (5 [3.7])	gG-32	PKZM0-25	25
B1	7.5–15 [5.5–11]	gG-25 (7.5 [5.5]) gG-32 (10 [7.5])	gG-80	PKZM4-63	63
B2	20 [15]	gG-50	gG-100	NZMB1-A100	100
B3	7.5–15 [5.5–11]	gG-25	gG-63	PKZM4-50	50
B4	20–25 [15–18]	gG-32 (10 [7.5]) gG-50 (15 [11]) gG-63 (20 [15])	gG-125	NZMB1-A100	100
C1	25–40 [18.5–30]	gG-63 (20 [15]) gG-80 (25 [18.5]) gG-100 (30 [22])	gG-160 (20–25 [15–18.5]) aR-160 (30 [22])	NZMB2-A200	160
C2	50–60 [37–45]	aR-160 (40 [30]) aR-200 (50 [37])	aR-200 (40 [30]) aR-250 (50 [37])	NZMB2-A250	250
C3	30–40 [22–30]	gG-80 (25 [18.5]) aR-125 (30 [22])	gG-150 (25 [18.5]) aR-160 (30 [22])	NZMB2-A200	150
C4	50–60 [37–45]	aR-160 (40 [30]) aR-200 (50 [37])	aR-200 (40 [30]) aR-250 (50 [37])	NZMB2-A250	250

**Table 10.12 200–240 V, Frame Sizes A, B and C**

**Specifications**
**VLT® AQUA Drive  
Instruction Manual**

Enclosure	Power (hp [kW])	Recommended fuse size	Recommended Max. fuse	Recommended circuit breaker Moeller	Max trip level [A]
A1	-	gG-10	gG-25	PKZM0-16	16
A2	1.5–5 [1.1–4.0]	gG-10 (0.5–4 [0.37–3]) gG-16 (5 [4])	gG-25	PKZM0-25	25
A3	7.5–10 [5.5–7.5]	gG-16	gG-32	PKZM0-25	25
A4	1.5–5 [1.1–4.0]	gG-10 (0.5–4 [0.37–3]) gG-16 (5 [4])	gG-32	PKZM0-25	25
A5	1.5–10 [1.1–7.5]	gG-10 (0.5–4 [0.37–3]) gG-16 (5–10 [4–7.5])	gG-32	PKZM0-25	25
B1	15–25 [11–18.5]	gG-40	gG-80	PKZM4-63	63
B2	30–40 [22–30]	gG-50 (25 [18.5]) gG-63 (30 [22])	gG-100	NZMB1-A100	100
B3	15–25 [11–18]	gG-40	gG-63	PKZM4-50	50
B4	30–50 [22–37]	gG-50 (25 [18.5]) gG-63 (30 [22]) gG-80 (40 [30])	gG-125	NZMB1-A100	100
C1	50–75 [37–55]	gG-80 (40 [30]) gG-100 (50 [37]) gG-160 (60 [45])	gG-160	NZMB2-A200	160
C2	100–125 [75–90]	aR-200 (75 [55]) aR-250 (100 [75])	aR-250	NZMB2-A250	250
C3	60–75 [45–55]	gG-100 (50 [37]) gG-160 (60 [45])	gG-150 (50 [37]) gG-160 (60 [45])	NZMB2-A200	150
C4	100–125 [75–90]	aR-200 (75 [55]) aR-250 (100 [75])	aR-250	NZMB2-A250	250

**Table 10.13 380–480 V, Frame Sizes A, B and C**



**Specifications**
**VLT® AQUA Drive  
Instruction Manual**

Enclosure	Power (hp [kW])	Recommended fuse size	Recommended Max. fuse	Recommended circuit breaker Moeller	Max trip level [A]
A2	1.5–5 [1.1–4.0]	gG-10	gG-25	PKZM0-25	25
A3	7.5–10 [5.5–7.5]	gG-10 (75 [5.5]) gG-16 (100 [7.5])	gG-32	PKZM0-25	25
A5	1.5–10 [1.1–7.5]	gG-10 (1–7.5 [0.75–5.5]) gG-16 (10 [7.5])	gG-32	PKZM0-25	25
B1	15–25 [11–18]	gG-25 (15 [11]) gG-32 (20 [15]) gG-40 (25 [18.5])	gG-80	PKZM4-63	63
B2	30–40 [22–30]	gG-50 (30 [22]) gG-63 (40 [30])	gG-100	NZMB1-A100	100
B3	15–25 [11–18.5]	gG-25 (15 [11]) gG-32 (20 [15])	gG-63	PKZM4-50	50
B4	30–50 [22–37]	gG-40 (25 [18.5]) gG-50 (30 [22]) gG-63 (40 [30])	gG-125	NZMB1-A100	100
C1	50–75 [37–55]	gG-63 (50 [37]) gG-100 (60 [45]) aR-160 (75 [55])	gG-160 (50–60 [37–45]) aR-250 (75 [55])	NZMB2-A200	160
C2	100–125 [75–90]	aR-200 (100 [75])	aR-250	NZMB2-A250	250
C3	60–75 [45–55]	gG-63 (50 [37]) gG-100 (60 [45])	gG-150	NZMB2-A200	150
C4	100–125 [75–90]	aR-160 (75 [55]) aR-200 (100 [75])	aR-250	NZMB2-A250	250

**Table 10.14 525–600 V, Frame Sizes A, B and C**

Enclosure	Power (hp [kW])	Recommended fuse size	Recommended max. fuse	Recommended circuit breaker Danfoss	Max trip level[A]
A3	1.5 [1.1]	gG-6	gG-25	CTI25M 10-16	16
	2 [1.5]	gG-6	gG-25	CTI25M 10-16	16
	3 [2.2]	gG-6	gG-25	CTI25M 10-16	16
	4 [3]	gG-10	gG-25	CTI25M 10-16	16
	5 [4]	gG-10	gG-25	CTI25M 10-16	16
	7.5 [5.5]	gG-16	gG-25	CTI25M 10-16	16
	10 [7.5]	gG-16	gG-25	CTI25M 10-16	16
B2	15 [11]	gG-25	gG-63		
	20 [15]	gG-25	gG-63		
	25 [18]	gG-32			
	30 [22]	gG-32			
C2	40 [30]	gG-40			
	50 [37]	gG-63	gG-80		
	60 [45]	gG-63	gG-100		
	75 [55]	gG-80	gG-125		
	100 [75]	gG-100	gG-160		
C3	50 [37]	gG-100	gG-125		
	60 [45]	gG-125	gG-160		
D	50 [37]	gG-125	gG-125		
	60 [45]	gG-160	gG-160		
	75-100 [55-75]	gG-200	gG-200		
	125 [90]	aR-250	aR-250		

Table 10.15 525–690 V, Frame Sizes A, C and D (non-UL fuses)

### 10.3.3 UL Compliance

Fuses or circuit breakers are mandatory to comply with UL for NEC 2009. We recommend using a selection of the following.

The fuses below are suitable for use on a circuit capable of delivering 100,000 Arms (symmetrical) with the following voltage

- 240 V
- 480 V
- 600 V
- 690 V

depending on the drive voltage rating. With the proper fusing, the drive Short Circuit Current Rating (SCCR) is 100,000 Arms.

Recommended max. fuse													
Power (hp [kW])	Max. prefuse size [A]	Bussmann JFHR2	Bussmann RK1	Bussmann J	Bussmann T	Bussmann CC	Bussmann CC	Bussmann CC	SIBA RK1	Littel fuse RK1	Ferraz-Shawmut CC	Ferraz-Shawmut RK1	Ferraz-Shawmut J
1.5 [1.1]	15	FWX-1 5	KTN- R15	JKS-15	JJN-15	FNQ- R-15	KTK- R-15	LP- CC-15	501790 6-016	KLN- R15	ATM-R15	A2K-15R	HSJ15
2 [1.5]	20	FWX-2 0	KTN- R20	JKS-20	JJN-20	FNQ- R-20	KTK- R-20	LP- CC-20	501790 6-020	KLN- R20	ATM-R20	A2K-20R	HSJ20
3 [2.2]	30*	FWX-3 0	KTN- R30	JKS-30	JJN-30	FNQ- R-30	KTK- R-30	LP- CC-30	501240 6-032	KLN- R30	ATM-R30	A2K-30R	HSJ30
4 [3.0]	35	FWX-3 5	KTN- R35	JKS-35	JJN-35				---	KLN- R35	---	A2K-35R	HSJ35
5 [3.7]	50	FWX-5 0	KTN- R50	JKS-50	JJN-50				501400 6-050	KLN- R50	---	A2K-50R	HSJ50
7.5 [5.5]	60**	FWX-6 0	KTN- R60	JKS-60	JJN-60				501400 6-063	KLN- R60	---	A2K-60R	HSJ60
10 [7.5]	80	FWX-8 0	KTN- R80	JKS-80	JJN-80				501400 6-080	KLN- R80	---	A2K-80R	HSJ80
20 [15]	150	FWX-1 50	KTN- R150	JKS-15 0	JJN-15 0				202822 0-150	KLN- R150		A2K-150R	HSJ150
30 [22]	200	FWX-2 00	KTN- R200	JKS-20 0	JJN-20 0				202822 0-200	KLN- R200		A2K-200R	HSJ200

**Table 10.16 1 x 200–240 V**

\* Siba allowed up to 32 A

\*\* Siba allowed up to 63 A

Recommended max. fuse													
Power (hp [kW])	Max. prefuse size [A]	Bussmann JFHR2	Bussmann RK1	Bussmann J	Bussmann T	Bussmann CC	Bussmann CC	Bussmann CC	SIBA RK1	Littel fuse RK1	Ferraz-Shawmut CC	Ferraz-Shawmut RK1	Ferraz-Shawmut J
10 [7.5]	60	FWH-60	KTS-R60	JKS-60	JJS-60				501400 6-063	KLS-R60	-	A6K-60R	HSJ60
15 [11]	80	FWH-80	KTS-R80	JKS-80	JJS-80				202822 0-100	KLS-R80	-	A6K-80R	HSJ80
30 [22]	150	FWH-150	KTS-R150	JKS-150	JJS-150				202822 0-160	KLS-R150	-	A6K-150R	HSJ150
50 [37]	200	FWH-200	KTS-R200	JKS-200	JJS-200				202822 0-200	KLS-200		A6K-200R	HSJ200

Table 10.17 1 x 380–500 V

*KTS fuses from Bussmann may substitute KTN for 240 V adjustable frequency drives*

*FWH fuses from Bussmann may substitute FWX for 240 V adjustable frequency drives*

*JJS fuses from Bussmann may substitute JJN for 240 V adjustable frequency drives*

*KLSR fuses from LITTLE FUSES may substitute KLNK fuses for 240 V adjustable frequency drives*

*A6KR fuses from FERRAZ SHAWMUT may substitute A2KR for 240 V adjustable frequency drives*

Recommended max. fuse						
Power (hp [kW])	Bussmann Type RK1 <sup>1)</sup>	Bussmann Type J	Bussmann Type T	Bussmann Type CC	Bussmann	Bussmann Type CC
0.34–0.5 [0.25–0.37]	KTN-R-05	JKS-05	JJN-05	FNQ-R-5	KTK-R-5	LP-CC-5
0.75–1.5 [0.55–1.1]	KTN-R-10	JKS-10	JJN-10	FNQ-R-10	KTK-R-10	LP-CC-10
2 [1.5]	KTN-R-15	JKS-15	JJN-15	FNQ-R-15	KTK-R-15	LP-CC-15
3 [2.2]	KTN-R-20	JKS-20	JJN-20	FNQ-R-20	KTK-R-20	LP-CC-20
4 [3.0]	KTN-R-25	JKS-25	JJN-25	FNQ-R-25	KTK-R-25	LP-CC-25
5 [3.7]	KTN-R-30	JKS-30	JJN-30	FNQ-R-30	KTK-R-30	LP-CC-30
7.5–10 [5.5–7.5]	KTN-R-50	KS-50	JJN-50	-	-	-
15 [11]	KTN-R-60	JKS-60	JJN-60	-	-	-
20 [15]	KTN-R-80	JKS-80	JJN-80	-	-	-
25–30 [18.5–22]	KTN-R-125	JKS-125	JJN-125	-	-	-
40 [30]	KTN-R-150	JKS-150	JJN-150	-	-	-
50 [37]	KTN-R-200	JKS-200	JJN-200	-	-	-
60 [45]	KTN-R-250	JKS-250	JJN-250	-	-	-

Table 10.18 3 x 200–240 V, Frame Sizes A, B and C

Power (hp [kW])	Recommended max. fuse			
	SIBA Type RK1	Littel fuse Type RK1	Ferraz- Shawmut Type CC	Ferraz- Shawmut Type RK1 <sup>3)</sup>
0.34–0.5 [0.25–0.37]	5017906-005	KLN-R-05	ATM-R-05	A2K-05-R
0.75–1.5 [0.55–1.1]	5017906-010	KLN-R-10	ATM-R-10	A2K-10-R
2 [1.5]	5017906-016	KLN-R-15	ATM-R-15	A2K-15-R
3 [2.2]	5017906-020	KLN-R-20	ATM-R-20	A2K-20-R
4 [3.0]	5017906-025	KLN-R-25	ATM-R-25	A2K-25-R
5 [3.7]	5012406-032	KLN-R-30	ATM-R-30	A2K-30-R
7.5–10 [5.5–7.5]	5014006-050	KLN-R-50	-	A2K-50-R
15 [11]	5014006-063	KLN-R-60	-	A2K-60-R
20 [15]	5014006-080	KLN-R-80	-	A2K-80-R
25–30 [18.5–22]	2028220-125	KLN-R-125	-	A2K-125-R
40 [30]	2028220-150	KLN-R-150	-	A2K-150-R
50 [37]	2028220-200	KLN-R-200	-	A2K-200-R
60 [45]	2028220-250	KLN-R-250	-	A2K-250-R

**Table 10.19 3 x 200–240 V, Frame Sizes A, B and C**

Power (hp [kW])	Recommended max. fuse			
	Bussmann Type JFHR2 <sup>2)</sup>	Littel fuse JFHR2	Ferraz- Shawmut JFHR2 <sup>4)</sup>	Ferraz- Shawmut J
0.34–0.5 [0.25–0.37]	FWX-5	-	-	HSJ-6
0.75–1.5 [0.55–1.1]	FWX-10	-	-	HSJ-10
2 [1.5]	FWX-15	-	-	HSJ-15
3 [2.2]	FWX-20	-	-	HSJ-20
4 [3.0]	FWX-25	-	-	HSJ-25
5 [3.7]	FWX-30	-	-	HSJ-30
7.5–10 [5.5–7.5]	FWX-50	-	-	HSJ-50
15 [11]	FWX-60	-	-	HSJ-60
20 [15]	FWX-80	-	-	HSJ-80
25–30 [18.5–22]	FWX-125	-	-	HSJ-125
40 [30]	FWX-150	L25S-150	A25X-150	HSJ-150
50 [37]	FWX-200	L25S-200	A25X-200	HSJ-200
60 [45]	FWX-250	L25S-250	A25X-250	HSJ-250

**Table 10.20 3 x 200–240 V, Frame Sizes A, B and C**

- 1) KTS fuses from Bussmann may substitute for KTN for 240 V adjustable frequency drives.
- 2) FWH fuses from Bussmann may substitute for FWX for 240 V adjustable frequency drives.
- 3) A6KR fuses from FERRAZ SHAWMUT may substitute for A2KR for 240 V adjustable frequency drives.
- 4) A50X fuses from FERRAZ SHAWMUT may substitute for A25X for 240 V adjustable frequency drives.

Power (hp [kW])	Recommended max. fuse					
	Bussmann Type RK1	Bussmann Type J	Bussmann Type T	Bussmann Type CC	Bussmann Type CC	Bussmann Type CC
-	KTS-R-6	JKS-6	JJS-6	FNQ-R-6	KTK-R-6	LP-CC-6
1.5-3 [1.1-2.2]	KTS-R-10	JKS-10	JJS-10	FNQ-R-10	KTK-R-10	LP-CC-10
4 [3]	KTS-R-15	JKS-15	JJS-15	FNQ-R-15	KTK-R-15	LP-CC-15
5 [4]	KTS-R-20	JKS-20	JJS-20	FNQ-R-20	KTK-R-20	LP-CC-20
7.5 [5.5]	KTS-R-25	JKS-25	JJS-25	FNQ-R-25	KTK-R-25	LP-CC-25
10 [7.5]	KTS-R-30	JKS-30	JJS-30	FNQ-R-30	KTK-R-30	LP-CC-30
15 [11]	KTS-R-40	JKS-40	JJS-40	-	-	-
20 [15]	KTS-R-50	JKS-50	JJS-50	-	-	-
30 [22]	KTS-R-60	JKS-60	JJS-60	-	-	-
40 [30]	KTS-R-80	JKS-80	JJS-80	-	-	-
50 [37]	KTS-R-100	JKS-100	JJS-100	-	-	-
60 [45]	KTS-R-125	JKS-125	JJS-125	-	-	-
75 [55]	KTS-R-150	JKS-150	JJS-150	-	-	-
100 [75]	KTS-R-200	JKS-200	JJS-200	-	-	-
125 [90]	KTS-R-250	JKS-250	JJS-250	-	-	-

**Table 10.21 3 x 380-480 V, Frame Sizes A, B and C**

Power (hp [kW])	Recommended max. fuse			
	SIBA Type RK1	Littel fuse Type RK1	Ferraz- Shawmut Type CC	Ferraz- Shawmut Type RK1
-	5017906-006	KLS-R-6	ATM-R-6	A6K-6-R
1.5-3 [1.1-2.2]	5017906-010	KLS-R-10	ATM-R-10	A6K-10-R
4 [3]	5017906-016	KLS-R-15	ATM-R-15	A6K-15-R
5 [4]	5017906-020	KLS-R-20	ATM-R-20	A6K-20-R
7.5 [5.5]	5017906-025	KLS-R-25	ATM-R-25	A6K-25-R
10 [7.5]	5012406-032	KLS-R-30	ATM-R-30	A6K-30-R
15 [11]	5014006-040	KLS-R-40	-	A6K-40-R
20 [15]	5014006-050	KLS-R-50	-	A6K-50-R
30 [22]	5014006-063	KLS-R-60	-	A6K-60-R
40 [30]	2028220-100	KLS-R-80	-	A6K-80-R
50 [37]	2028220-125	KLS-R-100	-	A6K-100-R
60 [45]	2028220-125	KLS-R-125	-	A6K-125-R
75 [55]	2028220-160	KLS-R-150	-	A6K-150-R
100 [75]	2028220-200	KLS-R-200	-	A6K-200-R
125 [90]	2028220-250	KLS-R-250	-	A6K-250-R

**Table 10.22 3 x 380-480 V, Frame Sizes A, B and C**

Power (hp [kW])	Recommended max. fuse			
	Bussmann JFHR2	Ferraz-Shawmut J	Ferraz-Shawmut JFHR2 <sup>1)</sup>	Littel fuse JFHR2
-	FWH-6	HSJ-6	-	-
1.5-3 [1.1-2.2]	FWH-10	HSJ-10	-	-
4 [3]	FWH-15	HSJ-15	-	-
5 [4]	FWH-20	HSJ-20	-	-
7.5 [5.5]	FWH-25	HSJ-25	-	-
10 [7.5]	FWH-30	HSJ-30	-	-
15 [11]	FWH-40	HSJ-40	-	-
20 [15]	FWH-50	HSJ-50	-	-
30 [22]	FWH-60	HSJ-60	-	-
40 [30]	FWH-80	HSJ-80	-	-
50 [37]	FWH-100	HSJ-100	-	-
60 [45]	FWH-125	HSJ-125	-	-
75 [55]	FWH-150	HSJ-150	-	-
100 [75]	FWH-200	HSJ-200	A50-P-225	L50-S-225
125 [90]	FWH-250	HSJ-250	A50-P-250	L50-S-250

Table 10.23 3 x 380-480 V, Frame Sizes A, B and C

1) Ferraz-Shawmut A50QS fuses may substitute for A50P fuses.

Power (hp [kW])	Recommended max. fuse					
	Bussmann Type RK1	Bussmann Type J	Bussmann Type T	Bussmann Type CC	Bussmann Type CC	Bussmann Type CC
1-1.5 [0.75-1.1]	KTS-R-5	JKS-5	JJS-6	FNQ-R-5	KTK-R-5	LP-CC-5
2-3 [1.5-2.2]	KTS-R-10	JKS-10	JJS-10	FNQ-R-10	KTK-R-10	LP-CC-10
4 [3]	KTS-R-15	JKS-15	JJS-15	FNQ-R-15	KTK-R-15	LP-CC-15
4	KTS-R-20	JKS-20	JJS-20	FNQ-R-20	KTK-R-20	LP-CC-20
7.5 [5.5]	KTS-R-25	JKS-25	JJS-25	FNQ-R-25	KTK-R-25	LP-CC-25
10 [7.5]	KTS-R-30	JKS-30	JJS-30	FNQ-R-30	KTK-R-30	LP-CC-30
15-20 [11-15]	KTS-R-35	JKS-35	JJS-35	-	-	-
25 [18]	KTS-R-45	JKS-45	JJS-45	-	-	-
30 [22]	KTS-R-50	JKS-50	JJS-50	-	-	-
40 [30]	KTS-R-60	JKS-60	JJS-60	-	-	-
50 [37]	KTS-R-80	JKS-80	JJS-80	-	-	-
60 [45]	KTS-R-100	JKS-100	JJS-100	-	-	-
75 [55]	KTS-R-125	JKS-125	JJS-125	-	-	-
100 [75]	KTS-R-150	JKS-150	JJS-150	-	-	-
125 [90]	KTS-R-175	JKS-175	JJS-175	-	-	-

Table 10.24 3 x 525-600 V, Frame Sizes A, B and C

**Specifications** **VLT® AQUA Drive**  
**Instruction Manual**

Power (hp [kW])	Recommended max. fuse			
	SIBA Type RK1	Littel fuse Type RK1	Ferraz- Shawmut Type RK1	Ferraz- Shawmut J
1–1.5 [0.75– 1.1]	5017906-005	KLS-R-005	A6K-5-R	HSJ-6
2–3 [1.5–2.2]	5017906-010	KLS-R-010	A6K-10-R	HSJ-10
4 [3]	5017906-016	KLS-R-015	A6K-15-R	HSJ-15
5 [4]	5017906-020	KLS-R-020	A6K-20-R	HSJ-20
7.5 [5.5]	5017906-025	KLS-R-025	A6K-25-R	HSJ-25
10 [7.5]	5017906-030	KLS-R-030	A6K-30-R	HSJ-30
15–20 [11–15]	5014006-040	KLS-R-035	A6K-35-R	HSJ-35
25 [18]	5014006-050	KLS-R-045	A6K-45-R	HSJ-45
30 [22]	5014006-050	KLS-R-050	A6K-50-R	HSJ-50
40 [30]	5014006-063	KLS-R-060	A6K-60-R	HSJ-60
50 [37]	5014006-080	KLS-R-075	A6K-80-R	HSJ-80
60 [45]	5014006-100	KLS-R-100	A6K-100-R	HSJ-100
75 [55]	2028220-125	KLS-R-125	A6K-125-R	HSJ-125
100 [75]	2028220-150	KLS-R-150	A6K-150-R	HSJ-150
125 [90]	2028220-200	KLS-R-175	A6K-175-R	HSJ-175

**Table 10.25 3 x 525–600 V, Frame Sizes A, B and C**

1) 170M fuses shown from Bussmann use the -/80 visual indicator. -TN/80 Type T, -/110 or TN/110 Type T indicator fuses of the same size and amperage may be substituted.

10

Power (hp [kW])	Max. prefuse [A]	Recommended max. fuse						
		Bussmann E52273 RK1/JDDZ	Bussmann E4273 J/JDDZ	Bussmann E4273 T/JDDZ	SIBA E180276 RK1/JDDZ	LittelFuse E81895 RK1/JDDZ	Ferraz- Shawmut E163267/E2137 RK1/JDDZ	Ferraz- Shawmut E2137 J/HSJ
15–20 [11– 15]	30	KTS-R-30	JKS-30	JKJS-30	5017906-030	KLS-R-030	A6K-30-R	HST-30
30 [22]	45	KTS-R-45	JKS-45	JJS-45	5014006-050	KLS-R-045	A6K-45-R	HST-45
40 [30]	60	KTS-R-60	JKS-60	JJS-60	5014006-063	KLS-R-060	A6K-60-R	HST-60
50 [37]	80	KTS-R-80	JKS-80	JJS-80	5014006-080	KLS-R-075	A6K-80-R	HST-80
60 [45]	90	KTS-R-90	JKS-90	JJS-90	5014006-100	KLS-R-090	A6K-90-R	HST-90
75 [55]	100	KTS-R-100	JKS-100	JJS-100	5014006-100	KLS-R-100	A6K-100-R	HST-100
100 [75]	125	KTS-R-125	JKS-125	JJS-125	2028220-125	KLS-150	A6K-125-R	HST-125
125 [90]	150	KTS-R-150	JKS-150	JJS-150	2028220-150	KLS-175	A6K-150-R	HST-150

\* UL-compliance 525–600 V only

**Table 10.26 3 x 525–690 V\*, Frame Sizes B and C**



## 10.4 Connection Tightening Torques

Enclosure	Power (hp [kW])			Torque (Nm)						
	200–240 V	380–480/500 V	525–600 V	525–690 V	Line power	Motor	DC connection	Brake	Ground	Relay
A2	0.34–3 [0.25–2.2]	0.5–5 [0.37–4.0]			1.8	1.8	1.8	1.8	3	0.6
A3	4–5 [3.0–3.7]	7.5–10 [5.5–7.5]	1–10 [0.75–7.5]	1.5–10 [1.1–7.5]	1.8	1.8	1.8	1.8	3	0.6
A4	0.34–3 [0.25–2.2]	0.5–5 [0.37–4.0]			1.8	1.8	1.8	1.8	3	0.6
A5	0.34–5 [0.25–3.7]	0.5–10 [0.37–7.5]	1–10 [0.75–7.5]		1.8	1.8	1.8	1.8	3	0.6
B1	7.5–10 [5.5–7.5]	15–20 [11–15]	15–20 [11–15]		1.8	1.8	1.5	1.5	3	0.6
B2	15 [11]	25 [18] 30 [22]	25 [18] 30 [22]	15 [11] 30 [22]	4.5 4.5	4.5 4.5	3.7 3.7	3.7 3.7	3 3	0.6 0.6
B3	7.5–10 [5.5–7.5]	15–20 [11–15]	15–20 [11–15]		1.8	1.8	1.8	1.8	3	0.6
B4	15–20 [11–15]	25–40 [18–30]	25–40 [18–30]		4.5	4.5	4.5	4.5	3	0.6
C1	20–30 [15–22]	40–60 [30–45]	40–60 [30–45]		10	10	10	10	3	0.6
C2	40–50 [30–37]	75–100 [55–75]	75–100 [55–75]	40–100 [30–75]	14/24 <sup>1)</sup>	14/24 <sup>1)</sup>	14	14	3	0.6
C3	25–30 [18–22]	50–60 [37–45]	50–60 [37–45]	60–75 [45–55]	10	10	10	10	3	0.6
C4	40–50 [30–37]	75–100 [55–75]	75–100 [55–75]		14/24 <sup>1)</sup>	14/24 <sup>1)</sup>	14	14	3	0.6

Table 10.27 Tightening of Terminals

<sup>1)</sup> For different cable dimensions x/y, where  $x \leq 95 \text{ mm}^2$  and  $y \geq 95 \text{ mm}^2$ .



## Index

### A

A53.....	2-12
A54.....	2-12

### AC

Input.....	1-4, 2-8
Line Power.....	1-3, 1-4, 2-3, 2-8
Line Voltage.....	4-2, 4-3, 7-1
Waveform.....	1-3, 1-4

Accel Time.....	3-6
-----------------	-----

Adjustable Frequency Drive Block Diagram.....	1-4
---	-----

Alarm Log.....	4-2
----------------	-----

Alarms.....	8-1
-------------	-----

### Analog

Inputs.....	2-9, 10-13
Output.....	2-9, 10-13

Application Examples.....	6-1
---------------------------	-----

Approvals.....	0-iv
----------------	------

### Auto

Auto.....	4-3
Mode.....	4-2
On.....	4-3, 7-1

Automatic Motor Adaptation.....	3-5, 7-1
---------------------------------	----------

Auto-reset.....	4-1
-----------------	-----

AWG.....	10-2
----------	------

### B

Backplate.....	2-2
----------------	-----

Braking.....	7-1
--------------	-----

### C

Cable Lengths And Cross-sections.....	10-13
---------------------------------------	-------

Circuit Breakers.....	3-2, 8-3
-----------------------	----------

### Clearance

Clearance.....	2-2
Requirements.....	2-1

Closed-loop.....	2-12
------------------	------

Conduit.....	2-5, 2-7, 3-2, 8-3
--------------	--------------------

### Control

Cables.....	2-11
Card Performance.....	10-16
Card, 10 V DC Output.....	10-15
Card, 24 V DC Output.....	10-14
Card, RS-485 Serial Communication.....	10-13
Card, USB Serial Communication.....	10-16
Characteristics.....	10-15
Signal.....	5-1, 5-2, 7-1
System.....	1-3
Terminals.....	2-3, 2-10, 3-4, 4-3, 7-1, 5-3
Wire.....	2-10
Wiring.....	2-5, 2-6, 2-10, 3-2, 8-3, 2-8

### Cooling

Cooling.....	2-1
Clearance.....	3-2, 8-3

Copying Parameter Settings.....	4-3
---------------------------------	-----

### Current

Limit.....	3-6
Rating.....	2-1

### D

Danfoss FC.....	2-13
-----------------	------

DC Current.....	1-4, 7-1
-----------------	----------

Derating.....	2-1
---------------	-----

### Digital

Input.....	2-11, 7-1
Inputs.....	2-9, 10-14, 5-3
Output.....	10-14

### Disconnect

Switch.....	3-3
Switches.....	3-1

Downloading Data From The LCP.....	4-4
------------------------------------	-----

### E

Electrical Noise.....	2-6
-----------------------	-----

EMC.....	3-2, 8-3
----------	----------

### External

Commands.....	1-4, 7-1
Controllers.....	1-3
Interlock.....	2-11, 5-3, 6-2
Voltage.....	5-2

### F

Fault Log.....	4-2
----------------	-----

Feedback.....	2-12, 3-2, 6-1, 8-3
---------------	---------------------

Floating Delta.....	2-8
---------------------	-----

Full Load Current.....	2-1
------------------------	-----

Functional Testing.....	1-3, 3-6
-------------------------	----------

Fuses.....	3-2, 8-3, 9-1
------------	---------------

Fusing.....	2-5, 8-3, 3-2
-------------	---------------

## G

### Ground

Connections.....	2-6, 3-2, 8-3
Loops.....	2-11
Wire.....	2-6, 3-2, 8-3

<b>Grounded Delta</b> .....	2-8
-----------------------------	-----

### Grounding

Grounding.....	2-6, 2-7, 2-8, 3-1, 3-2, 8-3
Using Shielded Cable.....	2-6

## H

### Hand

Hand.....	3-6, 4-3
On.....	3-6, 4-3

<b>Harmonics</b> .....	1-4
------------------------	-----

## I

<b>IEC 61800-3</b> .....	2-8
--------------------------	-----

<b>Induced Voltage</b> .....	2-5
------------------------------	-----

<b>Initialization</b> .....	4-4
-----------------------------	-----

### Input

Current.....	2-8
Disconnect.....	2-8
Power.....	1-4, 2-5, 2-6, 2-8, 3-1, 3-2, 8-1, 8-3, 9-1
Signal.....	5-2
Signals.....	2-11, 2-12
Terminals.....	2-3, 2-8, 2-12, 3-1
Voltage.....	3-3, 8-1

<b>Installation</b> .....	1-3, 2-1, 2-2, 2-5, 2-10, 2-13, 3-2, 3-3
---------------------------	--

<b>Isolated Line Power</b> .....	2-8
----------------------------------	-----

## J

<b>Johnson Controls N2®</b> .....	2-13
-----------------------------------	------

## L

<b>Leakage Current</b> .....	3-1
------------------------------	-----

<b>Lifting</b> .....	2-2
----------------------	-----

### Line

Power.....	2-5
Power Supply.....	10-2, 10-7
Power Supply (L1, L2, L3).....	10-12
Power Supply 1 X 200–240 V AC.....	10-1

### Local

Control.....	4-1, 4-3, 7-1
Control Panel.....	4-1
Control Test.....	3-6
Mode.....	3-6
Operation.....	4-1
Start.....	3-6

## M

<b>Main Menu</b> .....	4-2, 5-1
------------------------	----------

<b>Manual Initialization</b> .....	4-4
------------------------------------	-----

<b>Mechanical Brake Control</b> .....	2-12
---------------------------------------	------

### Menu

Keys.....	4-1, 4-2
Structure.....	4-3, 5-5, 5-4

<b>Modbus RTU</b> .....	2-13
-------------------------	------

### Motor

Cables.....	2-1, 2-5, 2-6
Current.....	1-4, 3-5, 4-2
Data.....	3-6, 3-5
Frequency.....	4-2
Output.....	10-12
Power.....	2-3, 2-5, 2-6, 4-2
Protection.....	2-5, 10-12
Rotation.....	3-6, 4-2
Speeds.....	3-3
Status.....	1-3
Wiring.....	2-5, 2-6, 3-2, 8-3

<b>Mounting</b> .....	2-2, 8-3
-----------------------	----------

### Multiple

Adjustable Frequency Drives.....	2-5, 2-6
Motors.....	3-1

## N

<b>Navigation Keys</b> .....	3-3, 5-1, 4-3
------------------------------	---------------

<b>Noise Isolation</b> .....	2-5, 3-2, 8-3
------------------------------	---------------

## O

<b>Open-loop</b> .....	2-12, 5-1
------------------------	-----------

<b>Operation Keys</b> .....	4-3
-----------------------------	-----

<b>Optional Equipment</b> .....	2-7, 2-12, 3-3
---------------------------------	----------------

### Output

Current.....	7-1
Performance (U, V, W).....	10-12
Signal.....	5-4
Terminals.....	2-3, 3-1

<b>Overcurrent</b> .....	7-1
--------------------------	-----

<b>Overload Protection</b> .....	2-1, 2-5
----------------------------------	----------

<b>Overvoltage</b> .....	3-6, 7-1
--------------------------	----------

## P

<b>PELV</b> .....	2-8, 6-4
-------------------	----------

### Power

Connections.....	2-5
Factor.....	1-4, 2-6, 3-2, 8-3

<b>Power-dependent</b> .....	10-1
------------------------------	------

<b>Pre-start</b> .....	3-1
------------------------	-----

**Programming**  
 Programming..... 1-3, 2-11, 3-6, 4-2, 5-4, 5-11, 4-1, 4-3  
 Example..... 5-1

**Protection And Features**..... 10-12

**Pulse Inputs**..... 10-14

**Q**

**Quick Menu**..... 4-2, 5-1, 5-4

**R**

**Ramp-down Time**..... 3-6

**Ramp-up Time**..... 3-6

**RCD**..... 2-6

**Reference**..... 0-iii, 6-1, 4-2

**Relay Outputs**..... 2-9, 10-14

**Remote**  
 Commands..... 1-3  
 Programming..... 5-11  
 Reference..... 7-1

**Reset**..... 4-1, 4-4, 7-1, 4-3

**RFI Filter**..... 2-8

**RMS Current**..... 1-4

**Run**  
 Command..... 3-7  
 Permissive..... 7-1

**S**

**Safe Stop**..... 1-5

**Safety Inspection**..... 3-1

**Serial Communication**..... 1-3, 2-9, 2-11, 4-3, 7-1, 10-16, 8-1, 2-13

**Setpoint**..... 7-1

**Set-up**..... 3-7, 4-2

**Shielded**  
 Cable..... 2-1, 2-5, 3-2, 8-3  
 Control Cables..... 2-11  
 Wire..... 2-5

**Sleep Mode**..... 7-1

**Specifications**..... 1-3, 2-2, 2-13, 10-1

**Speed Reference**..... 2-12, 3-7, 5-2, 7-1

**Start-up**..... 1-3, 4-4, 5-1

**Status Mode**..... 7-1

**Stop Command**..... 7-1

**Supply Voltage**..... 2-8, 2-9, 3-1

**Surroundings**..... 10-15

**Switching Frequency**..... 7-1

**Symbols**..... 0-iii

**System**  
 Feedback..... 1-3  
 Monitoring..... 8-1  
 Start-up..... 3-7

**T**

**Technical Data**..... 10-12

**Temperature Limits**..... 3-2, 8-3

**Terminal**  
 53..... 2-12, 5-1, 5-2  
 54..... 2-12  
 Programming..... 2-11  
 Programming Examples..... 5-3

**Thermistor**  
 Thermistor..... 2-8, 6-4  
 Control Wiring..... 2-8

**Tightening Of Terminals**..... 10-27

**Torque**  
 Characteristics..... 10-12  
 Limit..... 3-6

**Transient Protection**..... 1-4

**Trip**  
 Trip..... 8-1  
 Function..... 2-5  
 Lock..... 8-1

**Troubleshooting**..... 1-3

**U**

**Uploading Data To The LCP**..... 4-4

**V**

**Voltage Level**..... 10-14

**W**

**Warning**  
 And Alarm Definitions..... 8-3  
 And Alarm Displays..... 8-1  
 And Alarm Types..... 8-1

**Wire Sizes**..... 2-5, 2-6