



Operating Instructions VLT[®] AQUA Drive FC 202

0.25–90 kW



Contents

| | |
|--|-----------|
| 1 Introduction | 4 |
| 1.1 Purpose of the Operating Instructions | 4 |
| 1.2 Additional Resources | 4 |
| 1.3 Document and Software Version | 4 |
| 1.4 Product Overview | 4 |
| 1.5 Approvals and Certifications | 8 |
| 1.6 Disposal | 8 |
| 2 Safety | 9 |
| 2.1 Safety Symbols | 9 |
| 2.2 Qualified Personnel | 9 |
| 2.3 Safety Precautions | 9 |
| 3 Mechanical Installation | 11 |
| 3.1 Unpacking | 11 |
| 3.2 Installation Environments | 11 |
| 3.3 Mounting | 11 |
| 4 Electrical Installation | 13 |
| 4.1 Safety Instructions | 13 |
| 4.2 EMC-compliant Installation | 13 |
| 4.3 Grounding | 13 |
| 4.4 Wiring Schematic | 14 |
| 4.5 Access | 16 |
| 4.6 Motor Connection | 16 |
| 4.7 AC Mains Connection | 17 |
| 4.8 Control Wiring | 17 |
| 4.8.1 Control Terminal Types | 17 |
| 4.8.2 Wiring to Control Terminals | 19 |
| 4.8.3 Enabling Motor Operation (Terminal 27) | 19 |
| 4.8.4 Voltage/Current Input Selection (Switches) | 19 |
| 4.8.5 RS485 Serial Communication | 20 |
| 4.9 Installation Check List | 21 |
| 5 Commissioning | 22 |
| 5.1 Safety Instructions | 22 |
| 5.2 Applying Power | 22 |
| 5.3 Local Control Panel Operation | 22 |
| 5.3.1 Local Control Panel | 22 |
| 5.3.2 GLCP Layout | 22 |

| | |
|---|-----------|
| 5.3.3 Parameter Settings | 24 |
| 5.3.4 Uploading/Downloading Data to/from the LCP | 24 |
| 5.3.5 Changing Parameter Settings | 24 |
| 5.3.6 Restoring Default Settings | 24 |
| 5.4 Basic Programming | 25 |
| 5.4.1 Commissioning with SmartStart | 25 |
| 5.4.2 Commissioning via [Main Menu] | 25 |
| 5.4.3 Asynchronous Motor Set-up | 26 |
| 5.4.4 PM Motor Setup in VVC ⁺ | 27 |
| 5.4.5 SynRM Motor Set-up with VVC ⁺ | 28 |
| 5.4.6 Automatic Energy Optimisation (AEO) | 29 |
| 5.4.7 Automatic Motor Adaptation (AMA) | 29 |
| 5.5 Checking Motor Rotation | 29 |
| 5.6 Local-control Test | 29 |
| 5.7 System Start-up | 30 |
| 6 Application Set-up Examples | 31 |
| 7 Maintenance, Diagnostics and Troubleshooting | 35 |
| 7.1 Maintenance and Service | 35 |
| 7.2 Status Messages | 35 |
| 7.3 Warning and Alarm Types | 37 |
| 7.4 List of Warnings and Alarms | 38 |
| 7.5 Troubleshooting | 45 |
| 8 Specifications | 48 |
| 8.1 Electrical Data | 48 |
| 8.1.1 Mains Supply 1x200–240 V AC | 48 |
| 8.1.2 Mains Supply 3x200–240 V AC | 49 |
| 8.1.3 Mains Supply 1x380–480 V AC | 51 |
| 8.1.4 Mains Supply 3x380–480 V AC | 52 |
| 8.1.5 Mains Supply 3x525–600 V AC | 56 |
| 8.1.6 Mains Supply 3x525–690 V AC | 60 |
| 8.2 Mains Supply | 63 |
| 8.3 Motor Output and Motor Data | 63 |
| 8.4 Ambient Conditions | 64 |
| 8.5 Cable Specifications | 64 |
| 8.6 Control Input/Output and Control Data | 64 |
| 8.7 Connection Tightening Torques | 67 |
| 8.8 Fuses and Circuit Breakers | 68 |
| 8.9 Power Ratings, Weight, and Dimensions | 75 |

| | |
|---|----|
| 9 Appendix | 77 |
| 9.1 Symbols, Abbreviations, and Conventions | 77 |
| 9.2 Parameter Menu Structure | 77 |
| Index | 82 |

1 Introduction

1.1 Purpose of the Operating Instructions

These operating instructions provide information for safe installation and commissioning of the frequency converter.

The operating instructions are intended for use by qualified personnel.

Read and follow the operating instructions to use the frequency converter safely and professionally, and pay particular attention to the safety instructions and general warnings. Keep these operating instructions available with the frequency converter at all times.

VLT® is a registered trademark.

1.2 Additional Resources

Other resources are available to understand advanced frequency converter functions and programming.

- The *VLT® AQUA Drive FC 202 Programming Guide* provides greater detail on working with parameters and many application examples.
- The *VLT® AQUA Drive FC 202 Design Guide* provides detailed information about capabilities and functionality to design motor control systems.
- Instructions for operation with optional equipment.

Supplementary publications and manuals are available from Danfoss. See www.danfoss.com/BusinessAreas/DrivesSolutions/Documentations/VLT+Technical+Documentation.htm for listings.

1.3 Document and Software Version

This manual is regularly reviewed and updated. All suggestions for improvement are welcome. Please send suggestions via email to techcom_change_request@danfoss.com, including a reference to the document version.

Table 1.1 shows the document version and the corresponding software version.

| Edition | Remarks | Software version |
|----------|-------------------|------------------|
| MG20MCxx | Replaces MG20MBxx | 2.x |

Table 1.1 Document and Software Version

1.4 Product Overview

1.4.1 Intended Use

The frequency converter is an electronic motor controller intended for:

- Regulation of motor speed in response to system feedback or to remote commands from external controllers. A power drive system consists of the frequency converter, the motor, and equipment driven by the motor.
- System and motor status surveillance.

Depending on configuration, the frequency converter can be used in standalone applications or form part of a larger appliance or installation.

The frequency converter is allowed for use in residential, industrial, and commercial environments in accordance with local laws, standards, and emission limits as described in the design guide.

Single phase frequency converters (S2 and S4) installed in the EU

The following limitations apply:

- Units with an input current below 16 A and an input power above 1 kW are only intended for professional use in trades, professions, or industries and not for sale to the general public.
- Designated application areas are public pools, public water supplies, agriculture, commercial buildings, and industries. All other single phase units are only intended for use in private low-voltage systems interfacing with public supply only at a medium or high voltage level.
- Operators of private systems must ensure that the EMC environment complies with IEC 61000-3-6 and/or the contractual agreements.

NOTICE

In a residential environment, this product can cause radio interference, in which case supplementary mitigation measures may be required.

Foreseeable misuse

Do not use the frequency converter in applications, which are non-compliant with specified operating conditions and environments. Ensure compliance with the conditions specified in *chapter 8 Specifications*.

1.4.2 Features

The VLT® AQUA Drive FC 202 is designed for water and wastewater applications. The range of standard and optional features includes:

- Cascade control.
- Dry run detection.
- End of curve detection.
- SmartStart.
- Motor alternation.
- Deragging.
- 2-step ramps.
- Flow Confirmation.
- Check valve protection.
- Safe Torque Off.
- Low flow detection.
- Pre/Post Lubrication.
- Pipe fill mode.
- Sleep mode.
- Real-time clock.
- User configurable info texts.
- Warnings and alarms.
- Password protection.
- Overload protection.
- Smart logic control.
- Dual Power rating (High/Normal Overload).

1.4.3 Exploded Views

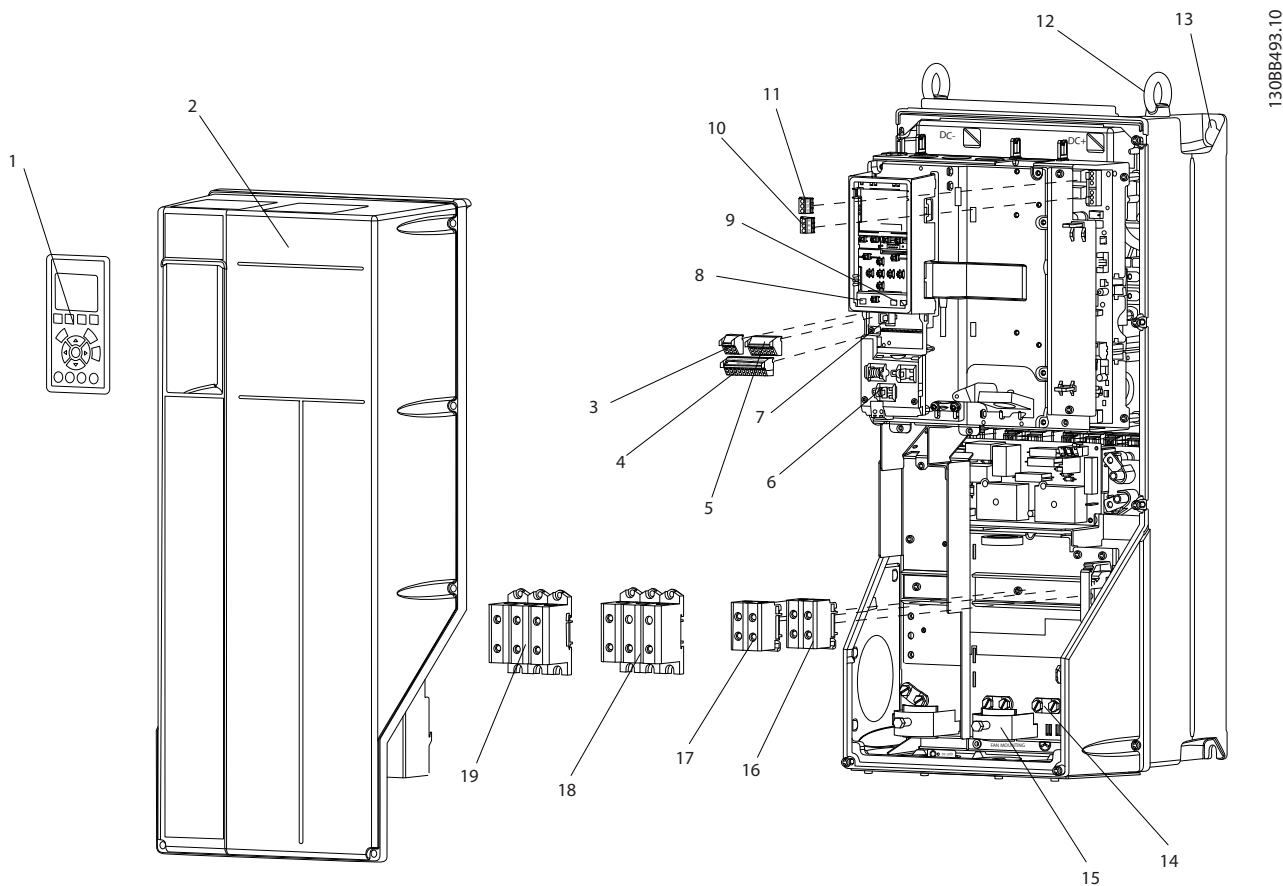

130BB493.10

| | | | |
|----|-----------------------------------|----|---|
| 1 | Local control panel (LCP) | 11 | Relay 2 (04, 05, 06) |
| 2 | Cover | 12 | Lifting ring |
| 3 | RS485 serial bus connector | 13 | Mounting slot |
| 4 | Digital I/O and 24 V power supply | 14 | Grounding clamp (PE) |
| 5 | Analog I/O connector | 15 | Cable screen connector |
| 6 | Cable screen connector | 16 | Brake terminal (-81, +82) |
| 7 | USB connector | 17 | Load sharing terminal (DC bus) (-88, +89) |
| 8 | Serial bus terminal switch | 18 | Motor output terminals 96 (U), 97 (V), 98 (W) |
| 9 | Analog switches (A53), (A54) | 19 | Mains input terminals 91 (L1), 92 (L2), 93 (L3) |
| 10 | Relay 1 (01, 02, 03) | | |

Illustration 1.1 Exploded View Enclosure Types B and C, IP55 and IP66

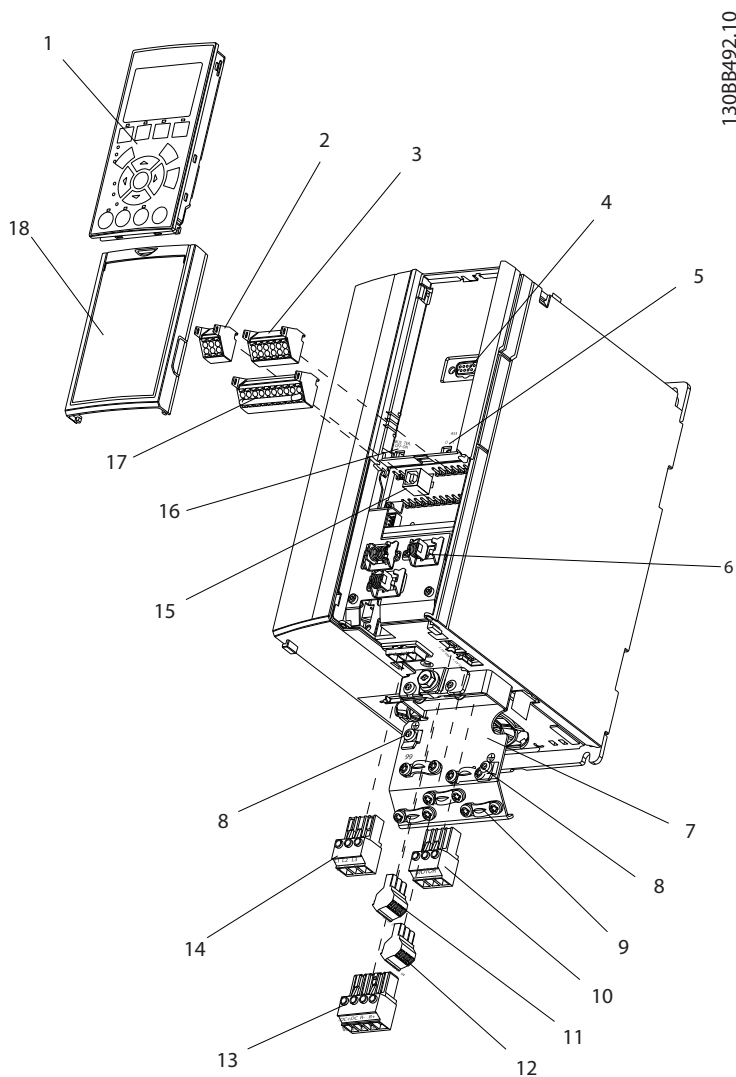

| | | | |
|---|--|----|--|
| 1 | Local control panel (LCP) | 10 | Motor output terminals 96 (U), 97 (V), 98 (W) |
| 2 | RS485 serial bus connector (+68, -69) | 11 | Relay 2 (01, 02, 03) |
| 3 | Analog I/O connector | 12 | Relay 1 (04, 05, 06) |
| 4 | LCP input plug | 13 | Brake (-81, +82) and load sharing (-88, +89) terminals |
| 5 | Analog switches (A53), (A54) | 14 | Mains input terminals 91 (L1), 92 (L2), 93 (L3) |
| 6 | Cable screen connector | 15 | USB connector |
| 7 | Decoupling plate | 16 | Serial bus terminal switch |
| 8 | Grounding clamp (PE) | 17 | Digital I/O and 24 V power supply |
| 9 | Screened cable grounding clamp and strain relief | 18 | Cover |

Illustration 1.2 Exploded View Enclosure Type A, IP20

Illustration 1.3 is a block diagram of the internal components of the frequency converter. See the table for Illustration 1.3 for their functions.

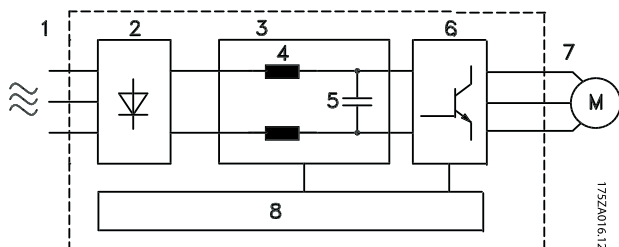

| Area | Title | Functions |
|------|-------------------|--|
| 1 | Mains input | <ul style="list-style-type: none"> 3-phase AC mains supply to the frequency converter. |
| 2 | Rectifier | <ul style="list-style-type: none"> The rectifier bridge converts the AC input to DC current to supply inverter power. |
| 3 | DC bus | <ul style="list-style-type: none"> Intermediate DC bus circuit handles the DC current. |
| 4 | DC reactors | <ul style="list-style-type: none"> Filter the intermediate DC circuit voltage. Prevent mains transient protection. Reduce RMS current. Raise the power factor reflected back to the line. Reduce harmonics on the AC input. |
| 5 | Capacitor bank | <ul style="list-style-type: none"> Stores the DC power. Provides ride-through protection for short power losses. |
| 6 | Inverter | <ul style="list-style-type: none"> Converts the DC into a controlled PWM AC waveform for a controlled variable output to the motor. |
| 7 | Output to motor | <ul style="list-style-type: none"> Regulated 3-phase output power to the motor. |
| 8 | Control circuitry | <ul style="list-style-type: none"> Input power, internal processing, output, and motor current are monitored to provide efficient operation and control. User interface and external commands are monitored and performed. Status output and control can be provided. |

Illustration 1.3 Frequency Converter Block Diagram

1.4 Enclosure Types and Power Ratings

For enclosure types and power ratings of the frequency converters, refer to chapter 8.9 Power Ratings, Weight, and Dimensions.

1.5 Approvals and Certifications



More approvals and certifications are available. Contact the local Danfoss partner. Frequency converters of enclosure type T7 (525–690 V) are UL certified for only 525–600 V.

The frequency converter complies with UL508C thermal memory retention requirements. For more information, refer to the section *Motor Thermal Protection* in the product specific design guide.

For compliance with the European Agreement concerning International Carriage of Dangerous Goods by Inland Waterways (ADN), refer to *ADN-compliant Installation* in the product specific design guide.

1.6 Disposal

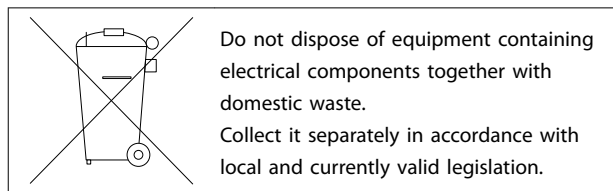

2 Safety

2.1 Safety Symbols

The following symbols are used in this manual:



Indicates a potentially hazardous situation that could result in death or serious injury.



Indicates a potentially hazardous situation that could result in minor or moderate injury. It can also be used to alert against unsafe practices.



Indicates important information, including situations that can result in damage to equipment or property.

2.2 Qualified Personnel

Correct and reliable transport, storage, installation, operation, and maintenance are required for the trouble-free and safe operation of the frequency converter. Only qualified personnel are allowed to install or operate this equipment.

Qualified personnel are defined as trained staff, who are authorised to install, commission, and maintain equipment, systems, and circuits in accordance with pertinent laws and regulations. Additionally, the qualified personnel must be familiar with the instructions and safety measures described in these operating instructions.

2.3 Safety Precautions



HIGH VOLTAGE

Frequency converters contain high voltage when connected to AC mains input, DC supply, or load sharing. Failure to perform installation, start-up, and maintenance by qualified personnel can result in death or serious injury.

- Installation, start-up, and maintenance must be performed by qualified personnel only.



UNINTENDED START

When the frequency converter is connected to AC mains, DC supply, or load sharing, the motor may start at any time. Unintended start during programming, service, or repair work can result in death, serious injury, or property damage. The motor can start via an external switch, a serial bus command, an input reference signal from the LCP, or after a cleared fault condition.

To prevent unintended motor start:

- Disconnect the frequency converter from the mains.
- Press [Off/Reset] on the LCP before programming parameters.
- Fully wire and assembly the frequency converter, motor, and any driven equipment before connecting the frequency converter to AC mains, DC supply, or load sharing.



DISCHARGE TIME

The frequency converter contains DC-link capacitors, which can remain charged even when the frequency converter is not powered. Failure to wait the specified time after power has been removed before performing service or repair work, could result in death or serious injury.

1. Stop the motor.
2. Disconnect the AC mains, permanent magnet type motors, and remote DC-link power supplies, including battery back-ups, UPS, and DC-link connections to other frequency converters.
3. Wait for the capacitors to discharge fully before performing any service or repair work. The duration of waiting time is specified in *Table 2.1*.

| Voltage [V] | Minimum waiting time (minutes) | | |
|-------------|--------------------------------|------------|-----------|
| | 4 | 7 | 15 |
| 200–240 | 0.25–3.7 kW | | 5.5–45 kW |
| 380–480 | 0.37–7.5 kW | | 11–90 kW |
| 525–600 | 0.75–7.5 kW | | 11–90 kW |
| 525–690 | | 1.1–7.5 kW | 11–90 kW |

High voltage may be present even when the warning LED indicator lights are off.

Table 2.1 Discharge Time

⚠ WARNING**LEAKAGE CURRENT HAZARD**

Leakage currents exceed 3.5 mA. Failure to ground the frequency converter properly can result in death or serious injury.

- Ensure the correct grounding of the equipment by a certified electrical installer.

⚠ WARNING**EQUIPMENT HAZARD**

Contact with rotating shafts and electrical equipment can result in death or serious injury.

- Ensure that only trained and qualified personnel perform installation, start up, and maintenance.
- Ensure that electrical work conforms to national and local electrical codes.
- Follow the procedures in this document.

⚠ WARNING**UNINTENDED MOTOR ROTATION
WINDMILLING**

Unintended rotation of permanent magnet motors creates voltage and can charge the unit, resulting in death, serious injury, or equipment damage.

- Ensure that permanent magnet motors are blocked to prevent unintended rotation.

⚠ CAUTION**INTERNAL FAILURE HAZARD**

An internal failure in the frequency converter can result in serious injury, when the frequency converter is not properly closed.

- Ensure that all safety covers are in place and securely fastened before applying power.

3 Mechanical Installation

3.1 Unpacking

3.1.1 Items Supplied

Items supplied may vary according to product configuration.

- Make sure the items supplied and the information on the nameplate correspond to the order confirmation.
- Check the packaging and the frequency converter visually for damage caused by inappropriate handling during shipment. File any claim for damage with the carrier. Retain damaged parts for clarification.

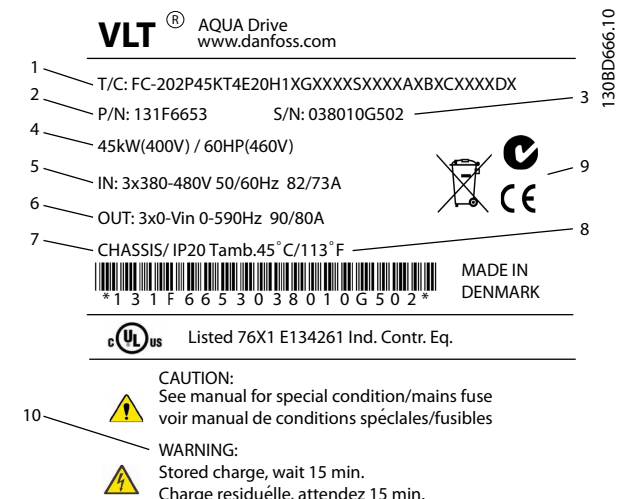

| | |
|----|--|
| 1 | Type code |
| 2 | Order number |
| 3 | Serial number |
| 4 | Power rating |
| 5 | Input voltage, frequency and current (at low/high voltages) |
| 6 | Output voltage, frequency and current (at low/high voltages) |
| 7 | Enclosure type and IP rating |
| 8 | Maximum ambient temperature |
| 9 | Certifications |
| 10 | Discharge time (Warning) |

Illustration 3.1 Product Nameplate (Example)

NOTICE

Do not remove the nameplate from the frequency converter. Removing the nameplate voids the warranty.

3.1.2 Storage

Ensure that the requirements for storage are fulfilled. Refer to chapter 8.4 Ambient Conditions for further details.

3.2 Installation Environments

NOTICE

In environments with airborne liquids, particles, or corrosive gases, ensure that the IP/type rating of the equipment matches the installation environment. Failure to meet requirements for ambient conditions can reduce the lifetime of the frequency converter. Ensure that requirements for air humidity, temperature, and altitude are met.

Vibration and shock

The frequency converter complies with requirements for units mounted on the walls and floors of production premises, as well as in panels bolted to walls or floors.

For detailed ambient conditions specifications, refer to chapter 8.4 Ambient Conditions.

3.3 Mounting

NOTICE

Improper mounting can result in overheating and reduced performance.

Cooling

- Ensure that top and bottom clearance for air cooling is provided. See Illustration 3.2 for clearance requirements.

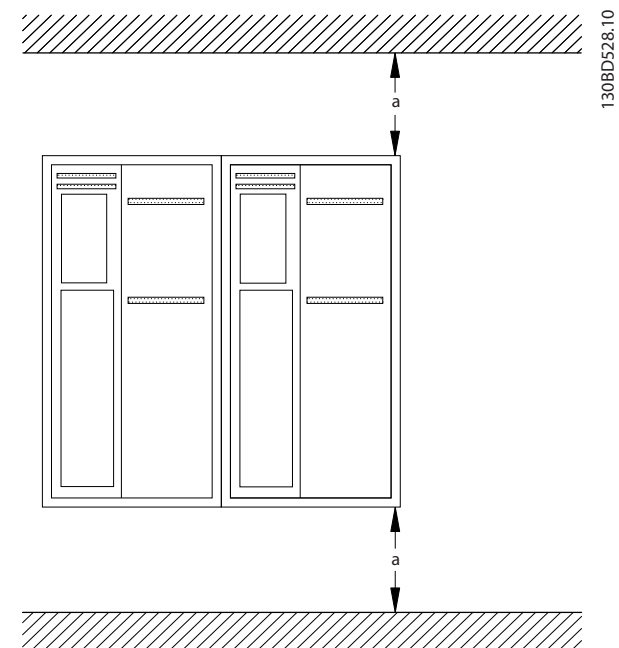

| Enclosure | A2-A5 | B1-B4 | C1, C3 | C2, C4 |
|-----------|-------|-------|--------|--------|
| a [mm] | 100 | 200 | 200 | 225 |

Illustration 3.2 Top and Bottom Cooling Clearance

Lifting

- To determine a safe lifting method, check the weight of the unit, see *chapter 8.9 Power Ratings, Weight, and Dimensions*.
- Ensure that the lifting device is suitable for the task.
- If necessary, plan for a hoist, crane, or forklift with the appropriate rating to move the unit.
- For lifting, use the hoist rings on the unit, when provided.

Mounting

1. Ensure that the strength of the mounting location supports the unit weight. The frequency converter allows side-by-side installation.
2. Locate the unit as near to the motor as possible. Keep the motor cables as short as possible.
3. Mount the unit vertically to a solid flat surface or to the optional back plate to provide cooling airflow.
4. Use the slotted mounting holes on the unit for wall mounting, when provided.

Mounting with back plate and railings

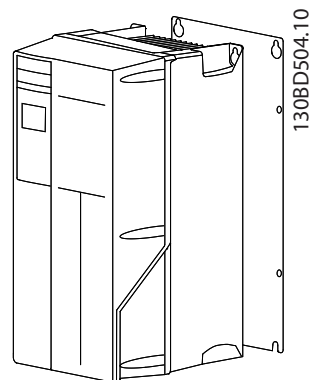

Illustration 3.3 Proper Mounting with Back Plate

NOTICE

A back plate is required when mounted on railings.

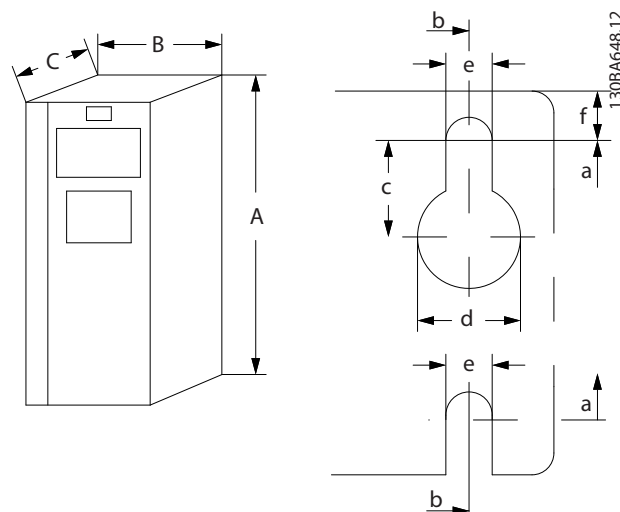

Illustration 3.4 Top and Bottom Mounting Holes (See *chapter 8.9 Power Ratings, Weight, and Dimensions*)

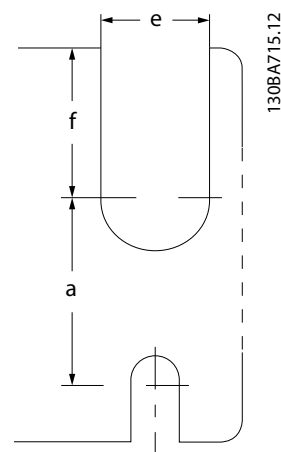

Illustration 3.5 Top and Bottom Mounting Holes (B4, C3, C4)

4 Electrical Installation

4.1 Safety Instructions

See *chapter 2 Safety* for general safety instructions.

WARNING

INDUCED VOLTAGE

Induced voltage from output motor cables that run together can charge equipment capacitors, even with the equipment turned off and locked out. Failure to run output motor cables separately or use screened cables could result in death or serious injury.

- Run output motor cables separately, or
- Use screened cables.

CAUTION

SHOCK HAZARD

The frequency converter can cause a DC current in the PE conductor. Failure to follow the recommendation below means the RCD may not provide the intended protection.

- When a residual current-operated protective device (RCD) is used for protection against electrical shock, only an RCD of Type B is permitted on the supply side.

Overcurrent protection

- Additional protective equipment, such as short-circuit protection or motor thermal protection between frequency converter and motor, is required for applications with multiple motors.
- Input fusing is required to provide short-circuit and overcurrent protection. If not factory-supplied, fuses must be provided by the installer. See maximum fuse ratings in *chapter 8.8 Fuses and Circuit Breakers*.

Wire type and ratings

- All wiring must comply with local and national regulations regarding cross-section and ambient temperature requirements.
- Power connection wire recommendation: Minimum 75 °C rated copper wire.

See *chapter 8.1 Electrical Data* and *chapter 8.5 Cable Specifications* for recommended wire sizes and types.

4.2 EMC-compliant Installation

To obtain an EMC-compliant installation, follow the instructions provided in *chapter 4.3 Grounding*, *chapter 4.4 Wiring Schematic*, *chapter 4.6 Motor Connection*, and *chapter 4.8 Control Wiring*.

4.3 Grounding

WARNING

LEAKAGE CURRENT HAZARD

Leakage currents exceed 3.5 mA. Failure to ground the frequency converter properly could result in death or serious injury.

- Ensure the correct grounding of the equipment by a certified electrical installer.

For electrical safety

- Ground the frequency converter in accordance with applicable standards and directives.
- Use a dedicated ground wire for input power, motor power, and control wiring.
- Do not ground one frequency converter to another in a daisy chain fashion.
- Keep the ground wire connections as short as possible.
- Follow motor manufacturer wiring requirements.
- Minimum cable cross-section: 10 mm² (or 2 rated ground wires terminated separately).

For EMC-compliant installation

- Establish electrical contact between the cable screen and the frequency converter enclosure by using metal cable glands or by using the clamps provided on the equipment (see *chapter 4.6 Motor Connection*).
- Use high-strand wire to reduce electrical interference.
- Do not use pigtailed.

NOTICE

POTENTIAL EQUALISATION

Risk of electrical interference, when the ground potential between the frequency converter and the control system is different. Install equalising cables between the system components. Recommended cable cross-section: 16 mm².

4.4 Wiring Schematic

4

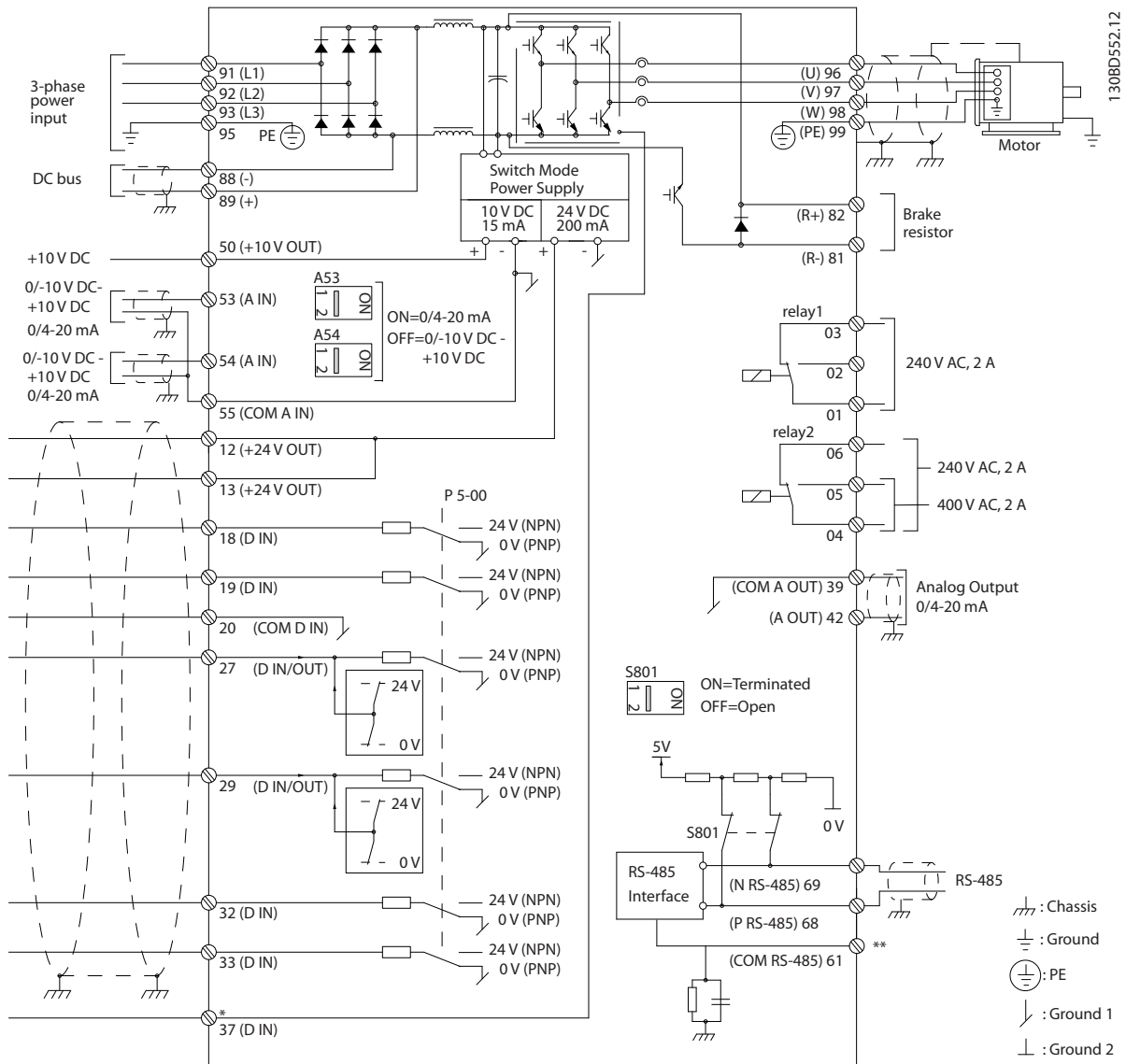
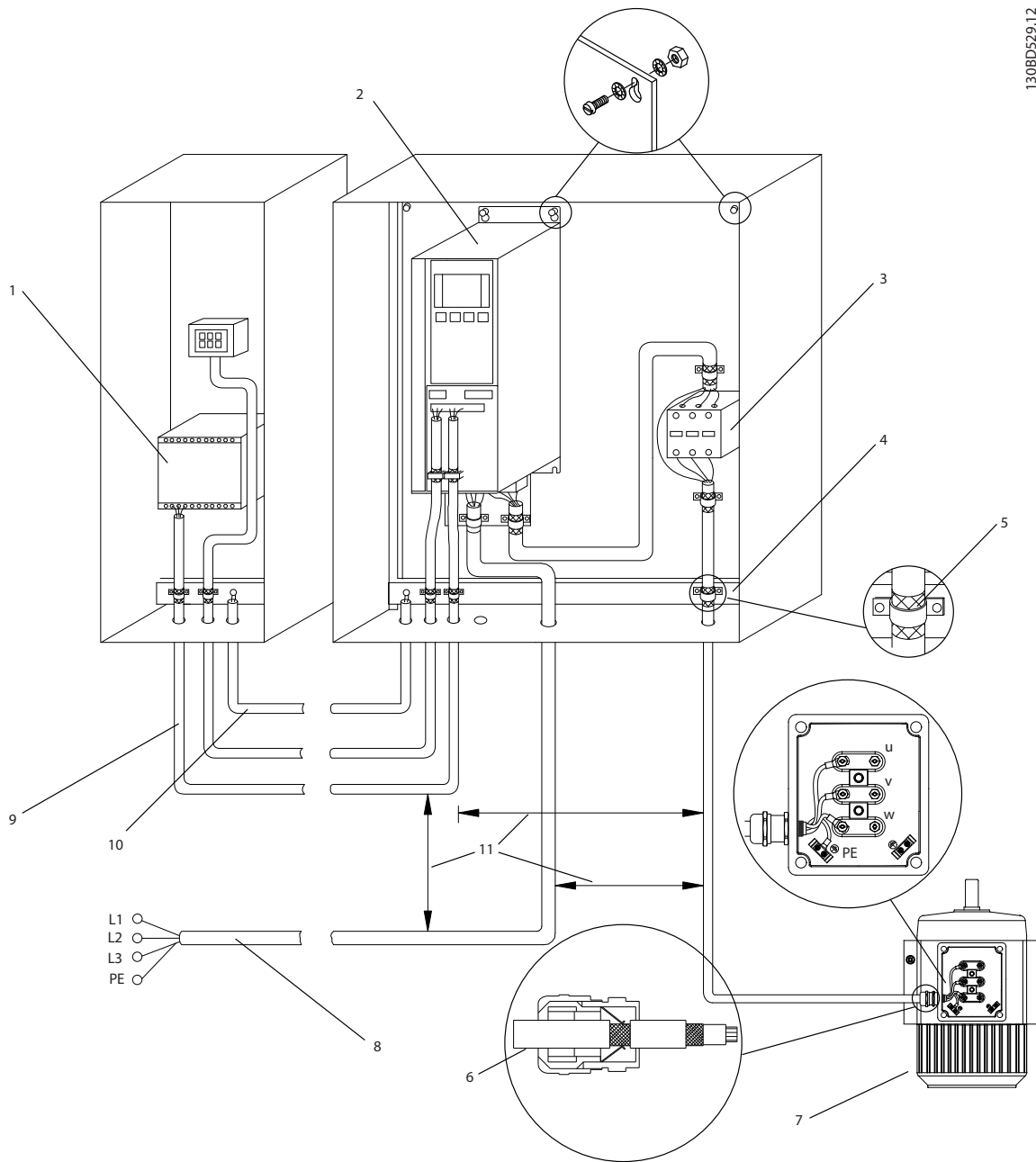

Illustration 4.1 Basic Wiring Schematic

A=Analog, D=Digital

*Terminal 37 (optional) is used for Safe Torque Off. For Safe Torque Off installation instructions, refer to the VLT® Frequency Converters - Safe Torque Off Operating Instructions.

**Do not connect cable screen.



| | | | |
|---|-----------------------------|----|---|
| 1 | PLC | 6 | Cable gland |
| 2 | Frequency converter | 7 | Motor, 3-phase and PE |
| 3 | Output contactor | 8 | Mains, 3-phase and reinforced PE |
| 4 | Grounding rail (PE) | 9 | Control wiring |
| 5 | Cable insulation (stripped) | 10 | Equalising min. 16 mm ² (0.025 in ²) |

Illustration 4.2 EMC-compliant Electrical Connection

NOTICE

EMC INTERFERENCE

Use screened cables for motor and control wiring and separate cables for input power, motor wiring, and control wiring. Failure to isolate power, motor, and control cables can result in unintended behaviour or reduced performance. Minimum clearance requirement between power, motor and control cables is 200 mm (7.9 in).

4.5 Access

- Remove the cover with a screw driver (See *Illustration 4.3*) or by loosening the attaching screws (See *Illustration 4.4*).

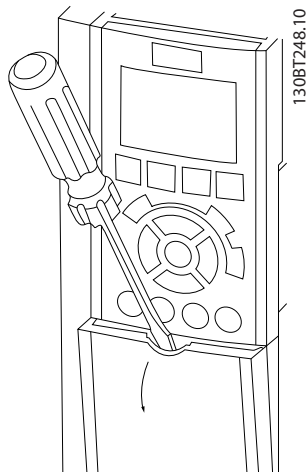

Illustration 4.3 Access to Wiring for IP20 and IP21 Enclosures

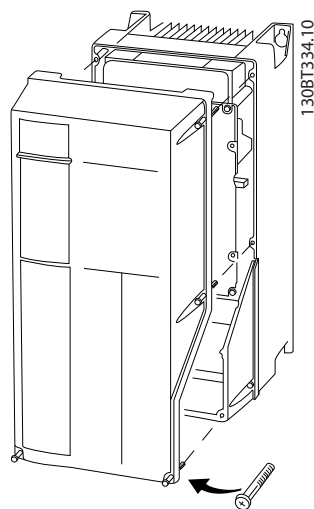

Illustration 4.4 Access to Wiring for IP55 and IP66 Enclosures

Tighten the cover screws using the tightening torques specified in *Table 4.1*.

| Enclosure | IP55 | IP66 |
|---|------|------|
| A4/A5 | 2 | 2 |
| B1/B2 | 2.2 | 2.2 |
| C1/C2 | 2.2 | 2.2 |
| No screws to tighten for A2/A3/B3/B4/C3/C4. | | |

Table 4.1 Tightening Torques for Covers [Nm]

4.6 Motor Connection

WARNING

INDUCED VOLTAGE

Induced voltage from output motor cables that run together can charge equipment capacitors, even with the equipment turned off and locked out. Failure to run output motor cables separately or use screened cables could result in death or serious injury.

- Run output motor cables separately, or
- Use screened cables.
- Comply with local and national electrical codes for cable sizes. For maximum wire sizes see *chapter 8.1 Electrical Data*.
- Follow motor manufacturer wiring requirements.
- Motor wiring knockouts or access panels are provided at the base of IP21 (NEMA1/12) and higher units.
- Do not wire a starting or pole-changing device (e.g. Dahlander motor or slip ring induction motor) between the frequency converter and the motor.

Procedure

- Strip a section of the outer cable insulation.
- Position the stripped wire under the cable clamp to establish mechanical fixation and electrical contact between the cable screen and ground.
- Connect the ground wire to the nearest grounding terminal in accordance with the grounding instructions provided in *chapter 4.3 Grounding*, see *Illustration 4.5*.
- Connect the 3-phase motor wiring to terminals 96 (U), 97 (V), and 98 (W), see *Illustration 4.5*.
- Tighten the terminals in accordance with the information provided in *chapter 8.7 Connection Tightening Torques*.

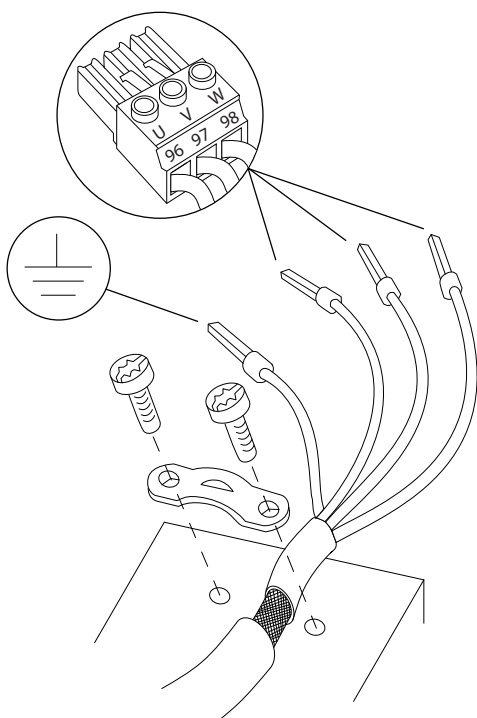

Illustration 4.5 Motor Connection

1308D531.10

Illustration 4.6 represents mains input, motor and grounding for basic frequency converters. Actual configurations vary with unit types and optional equipment.

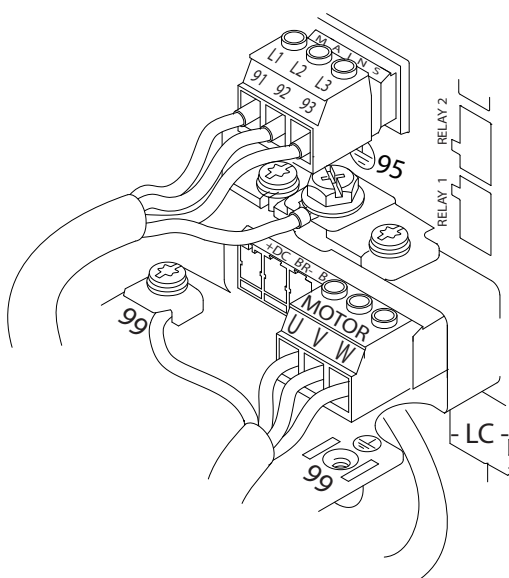

Illustration 4.6 Example of Motor, Mains and Ground Wiring

1308B920.10

4.7 AC Mains Connection

- Size the wiring based upon the input current of the frequency converter. For maximum wire sizes, see *chapter 8.1 Electrical Data*.
- Comply with local and national electrical codes for cable sizes.

Procedure

1. Connect the 3-phase AC input power wiring to terminals L1, L2, and L3 (see *Illustration 4.6*).
2. Depending on the configuration of the equipment, connect the input power to the mains input terminals or the input disconnect.
3. Ground the cable in accordance with the grounding instructions provided in *chapter 4.3 Grounding*.
4. When supplied from an isolated mains source (IT mains or floating delta) or TT/TN-S mains with a grounded leg (grounded delta), ensure that 14-50 RFI Filter is set to [0] Off to avoid damage to the intermediate circuit and to reduce ground capacity currents in accordance with IEC 61800-3.

4

4.8 Control Wiring

- Isolate the control wiring from the high-power components in the frequency converter.
- When the frequency converter is connected to a thermistor, ensure that the thermistor control wiring is screened and reinforced/double insulated. A 24 V DC supply voltage is recommended.

4.8.1 Control Terminal Types

Illustration 4.7 and Illustration 4.8 show the removable frequency converter connectors. Terminal functions and default settings are summarised in *Table 4.2*.

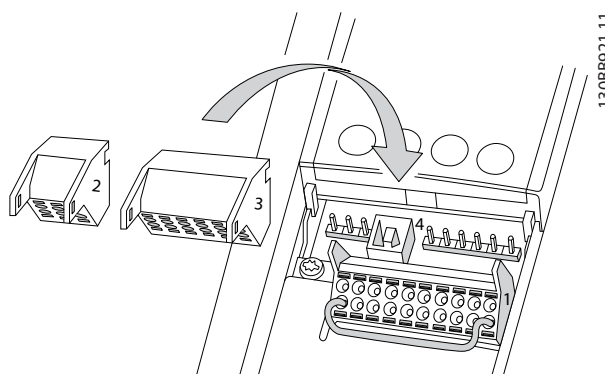

Illustration 4.7 Control Terminal Locations

1308B921.11

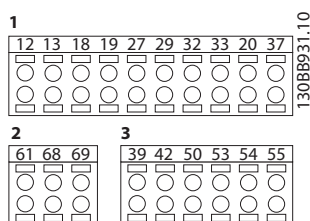

Illustration 4.8 Terminal Numbers

4

- Connector 1** provides:
 - 4 programmable digital inputs terminals.
 - 2 additional digital terminals programmable as either input or output.
 - 24 V DC terminal supply voltage.
 - Optional customer supplied 24 V DC voltage.
- Connector 2** terminals (+)68 and (-)69 are for an RS485 serial communication connection.
- Connector 3** provides:
 - 2 analog inputs.
 - 1 analog output.
 - 10 V DC supply voltage.
 - Commons for the inputs and output.
- Connector 4** is a USB port available for use with the MCT 10 Set-up Software.

| Terminal description | | | |
|-------------------------------|-----------|-------------------|---|
| Terminal | Parameter | Default setting | Description |
| Digital Inputs/Outputs | | | |
| 12, 13 | - | +24 V DC | 24 V DC supply voltage for digital inputs and external transducers. Maximum output current 200 mA for all 24 V loads. |
| 18 | 5-10 | [8] Start | Digital inputs. |
| 19 | 5-11 | [0] No operation | |
| 32 | 5-14 | [0] No operation | |
| 33 | 5-15 | [0] No operation | |
| 27 | 5-12 | [2] Coast inverse | For digital input or output. Default setting is input. |
| 29 | 5-13 | [14] JOG | |
| 20 | - | | Common for digital inputs and 0 V potential for 24 V supply. |

| Terminal description | | | |
|------------------------------|-----------|-----------------------|---|
| Terminal | Parameter | Default setting | Description |
| 37 | - | Safe Torque Off (STO) | Safe input (optional). Used for STO. |
| Analog Inputs/Outputs | | | |
| 39 | - | | Common for analog output |
| 42 | 6-50 | Speed 0 - High Limit | Programmable analog output. 0–20 mA or 4–20 mA at a maximum of 500 Ω |
| 50 | - | +10 V DC | 10 V DC analog supply voltage for potentiometer or thermistor. 15 mA maximum |
| 53 | 6-1 | Reference | Analog input. For voltage or current. Switches A53 and A54 select mA or V. |
| 54 | 6-2 | Feedback | |
| 55 | - | | Common for analog input |
| Serial Communication | | | |
| 61 | - | | Integrated RC-Filter for cable screen. ONLY for connecting the screen in the event of EMC problems. |
| 68 (+) | 8-3 | | RS485 Interface. A control card switch is provided for termination resistance. |
| 69 (-) | 8-3 | | |
| Relays | | | |
| 01, 02, 03 | 5-40 [0] | [9] Alarm | Form C relay output. |
| 04, 05, 06 | 5-40 [1] | [5] Running | For AC or DC voltage and resistive or inductive loads. |

Table 4.2 Terminal Description

Additional terminals:

- 2 form C relay outputs. Location of the outputs depends on frequency converter configuration.
- Terminals located on built-in optional equipment. See the manual provided with the equipment option.

4.8.2 Wiring to Control Terminals

Control terminal connectors can be unplugged from the frequency converter for ease of installation, as shown in *Illustration 4.9*.

NOTICE

Keep control wires as short as possible and separate from high power cables to minimise interference.

1. Open the contact by inserting a small screwdriver into the slot above the contact and push the screwdriver slightly upwards.

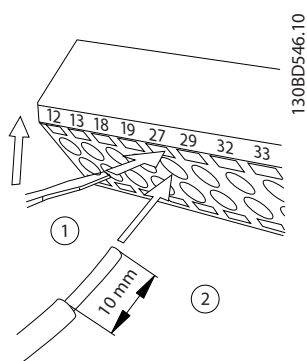

Illustration 4.9 Connecting Control Wires

2. Insert the bare control wire into the contact.
3. Remove the screwdriver to fasten the control wire into the contact.
4. Ensure that the contact is firmly established and not loose. Loose control wiring can be the source of equipment faults or less than optimal operation.

See *chapter 8.5 Cable Specifications* for control terminal wiring sizes and *chapter 6 Application Set-up Examples* for typical control wiring connections.

4.8.3 Enabling Motor Operation (Terminal 27)

A jumper wire is required between terminal 12 (or 13) and terminal 27 for the frequency converter to operate when using factory default programming values.

- Digital input terminal 27 is designed to receive 24 V DC external interlock command.
- When no interlock device is used, wire a jumper between control terminal 12 (recommended) or 13 to terminal 27. The jumper provides an internal 24 V signal on terminal 27.

- When the status line at the bottom of the LCP reads *AUTO REMOTE COAST*, it indicates that the unit is ready to operate but is missing an input signal on terminal 27.
- When factory installed optional equipment is wired to terminal 27, do not remove that wiring.

4.8.4 Voltage/Current Input Selection (Switches)

The analog input terminals 53 and 54 allow setting of input signal to voltage (0–10 V) or current (0/4–20 mA).

Default parameter setting:

- Terminal 53: Speed reference signal in open loop (see *16-61 Terminal 53 Switch Setting*).
- Terminal 54: Feedback signal in closed loop (see *16-63 Terminal 54 Switch Setting*).

NOTICE

Disconnect power to the frequency converter before changing switch positions.

1. Remove the LCP (local control panel) (see *Illustration 4.10*).
2. Remove any optional equipment covering the switches.
3. Set switches A53 and A54 to select the signal type. U selects voltage, I selects current.

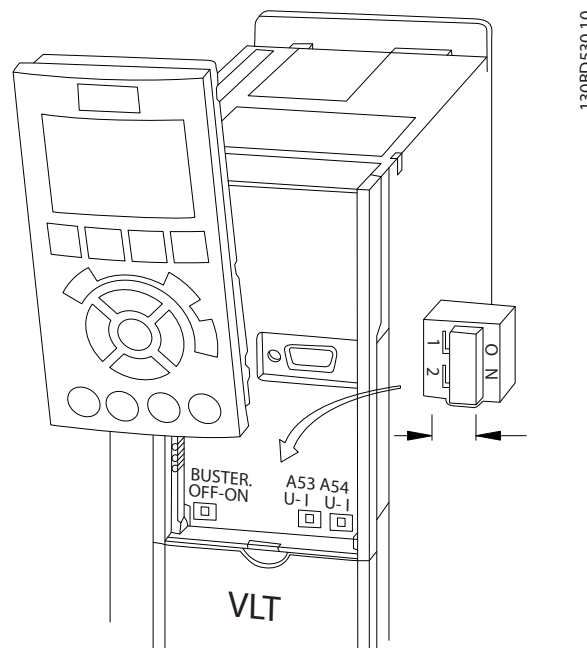

Illustration 4.10 Location of Terminal 53 and 54 Switches

To run STO, additional wiring for the frequency converter is required. Refer to *VLT® Frequency Converters Safe Torque Off Operating Instructions* for further information.

4.8.5 RS485 Serial Communication

Connect RS485 serial communication wiring to terminals (+)68 and (-)69.

4

- Use screened serial communication cable (recommended).
- See *chapter 4.3 Grounding* for proper grounding.

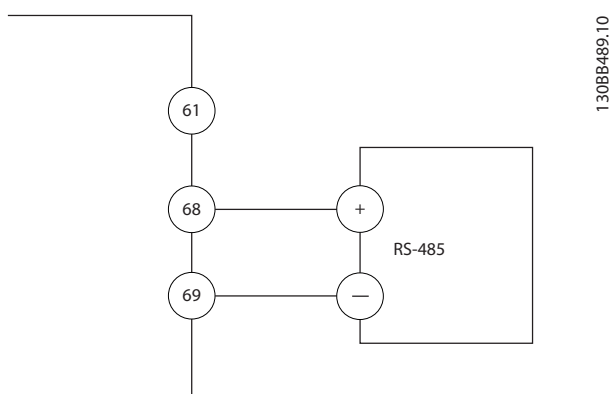

Illustration 4.11 Serial Communication Wiring Diagram

For basic serial communication set-up, select the following:

1. Protocol type in *8-30 Protocol*.
 2. Frequency converter address in *8-31 Address*.
 3. Baud rate in *8-32 Baud Rate*.
- 2 communication protocols are internal to the frequency converter.
 - Danfoss FC
 - Modbus RTU
 - Functions can be programmed remotely using the protocol software and RS485 connection or in parameter group *8-** Communications and Options*.
 - Selecting a specific communication protocol changes various default parameter settings to match that protocol's specifications and makes additional protocol-specific parameters available.
 - Option cards for the frequency converter are available to provide additional communication protocols. See the option card documentation for installation and operation instructions.

4.9 Installation Check List

Before completing installation of the unit, inspect the entire installation as detailed in *Table 4.3*. Check and mark the items when completed.

| Inspect for | Description | ☑ |
|-------------------------------|---|---|
| Auxiliary equipment | <ul style="list-style-type: none"> Look for auxiliary equipment, switches, disconnects, or input fuses/circuit breakers, which may reside on the input power side of the frequency converter or output side to the motor. Ensure that they are ready for full-speed operation. Check the function and installation of any sensors used for feedback to the frequency converter. Remove any power factor correction caps on the motor(s). Adjust any power factor correction caps on the mains side and ensure that they are dampened. | |
| Cable routing | <ul style="list-style-type: none"> Ensure that the motor wiring and control wiring are separated, screened, or in 3 separate metallic conduits for high-frequency interference isolation. | |
| Control wiring | <ul style="list-style-type: none"> Check for broken or damaged wires and loose connections. Check that the control wiring is isolated from power and motor wiring for noise immunity. Check the voltage source of the signals, if necessary. <p>The use of screened cable or twisted pair is recommended. Ensure that the shield is terminated correctly.</p> | |
| Cooling clearance | <ul style="list-style-type: none"> Ensure the top and bottom clearance is adequate to ensure proper air flow for cooling, see <i>chapter 3.3 Mounting</i>. | |
| Ambient conditions | <ul style="list-style-type: none"> Check that requirements for ambient conditions are met. | |
| Fusing and circuit breakers | <ul style="list-style-type: none"> Check for proper fusing or circuit breakers. Check that all fuses are inserted firmly and are in operational condition and that all circuit breakers are in the open position. | |
| Grounding | <ul style="list-style-type: none"> Check for sufficient ground connections and ensure the those are tight and free of oxidation. Grounding to conduit, or mounting the back panel to a metal surface, is not a suitable grounding. | |
| Input and output power wiring | <ul style="list-style-type: none"> Check for loose connections. Check that the motor and mains cables are in separate conduit or separated screened cables. | |
| Panel interior | <ul style="list-style-type: none"> Inspect that the unit interior is free of dirt, metal chips, moisture, and corrosion. Check that the unit is mounted on an unpainted, metal surface. | |
| Switches | <ul style="list-style-type: none"> Ensure that all switch and disconnect settings are in the proper positions. | |
| Vibration | <ul style="list-style-type: none"> Check that the unit is mounted solidly, or that shock mounts are used, as necessary. Check for an unusual amount of vibration. | |

Table 4.3 Installation Check List

CAUTION

POTENTIAL HAZARD IN THE EVENT OF INTERNAL FAILURE

Risk of personal injury if the frequency converter is not properly closed.

- Before applying power, ensure all safety covers are in place and securely fastened.

5 Commissioning

5.1 Safety Instructions

See *chapter 2 Safety* for general safety instructions.

⚠ WARNING

HIGH VOLTAGE

Frequency converters contain high voltage when connected to AC mains input power. Failure to perform installation, start-up, and maintenance by qualified personnel could result in death or serious injury.

- Installation, start-up, and maintenance must be performed by qualified personnel only.

Before applying power:

1. Close the cover properly.
2. Check that all cable glands are firmly tightened.
3. Ensure that input power to the unit is OFF and locked out. Do not rely on the frequency converter disconnect switches for input power isolation.
4. Verify that there is no voltage on input terminals L1 (91), L2 (92), and L3 (93), phase-to-phase and phase-to-ground.
5. Verify that there is no voltage on output terminals 96 (U), 97 (V), and 98 (W), phase-to-phase and phase-to-ground.
6. Confirm continuity of the motor by measuring Ω values on U-V (96-97), V-W (97-98), and W-U (98-96).
7. Check for proper grounding of the frequency converter as well as the motor.
8. Inspect the frequency converter for loose connections on the terminals.
9. Confirm that the supply voltage matches the voltage of the frequency converter and the motor.

5.2 Applying Power

Apply power to the frequency converter using the following steps:

1. Confirm that the input voltage is balanced within 3%. If not, correct the input voltage imbalance before proceeding. Repeat this procedure after the voltage correction.
2. Ensure that any optional equipment wiring, matches the installation application.

3. Ensure that all operator devices are in the OFF position. Panel doors must be closed and covers securely fastened.
4. Apply power to the unit. DO NOT start the frequency converter now. For units with a disconnect switch, turn it to the ON position to apply power to the frequency converter.

5.3 Local Control Panel Operation

5.3.1 Local Control Panel

The local control panel (LCP) is the combined display and keypad on the front of the unit.

The LCP has several user functions:

- Start, stop, and control speed when in local control.
- Display operational data, status, warnings and cautions.
- Programme frequency converter functions.
- Manually reset the frequency converter after a fault when auto-reset is inactive.

An optional numeric LCP (NLCP) is also available. The NLCP operates in a manner similar to the LCP. See the product relevant programming guide for details on use of the NLCP.

NOTICE

For commissioning via PC, install the MCT 10 Set-up Software. The software is available for download (basic version) or for ordering (advanced version, order number 130B1000). For more information and downloads, see www.danfoss.com/BusinessAreas/DrivesSolutions/Software+MCT10/MCT10+Downloads.htm.

5.3.2 GLCP Layout

The GLCP is divided into 4 functional groups (see *Illustration 5.1*).

- A. Display area
- B. Display menu keys
- C. Navigation keys and indicator lights (LEDs)
- D. Operation keys and reset

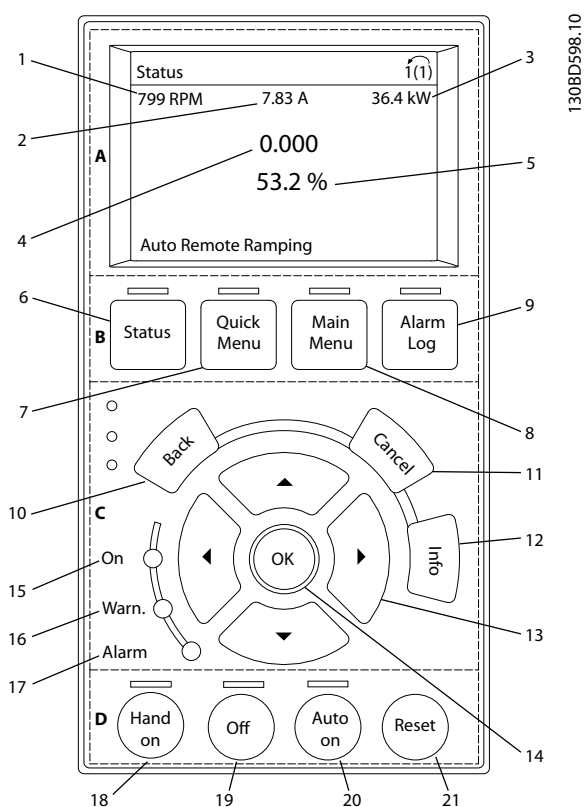

Illustration 5.1 Graphic Local Control Panel (GLCP)

A. Display area

The display area is activated when the frequency converter receives power from the mains voltage, a DC bus terminal, or an external 24 V DC supply.

The information displayed on the LCP can be customised for user application. Select options in the *Quick Menu Q3-13 Display Settings*.

| Display | Parameter number | Default setting |
|---------|------------------|-----------------|
| 1 | 0-20 | Speed [RPM] |
| 2 | 0-21 | Motor Current |
| 3 | 0-22 | Power [kW] |
| 4 | 0-23 | Frequency |
| 5 | 0-24 | Reference [%] |

Table 5.1 Legend to Illustration 5.1, Display Area

B. Display menu keys

Menu keys are used for menu access for parameter set-up, toggling through status display modes during normal operation, and viewing fault log data.

| Key | Function |
|--------------|---|
| 6 Status | Shows operational information. |
| 7 Quick Menu | Allows access to programming parameters for initial set-up instructions and many detailed application instructions. |

| Key | Function |
|-------------|---|
| 8 Main Menu | Allows access to all programming parameters. |
| 9 Alarm Log | Displays a list of current warnings, the last 10 alarms, and the maintenance log. |

Table 5.2 Legend to Illustration 5.1, Display Menu Keys

C. Navigation keys and indicator lights (LEDs)

Navigation keys are used for programming functions and moving the display cursor. The navigation keys also provide speed control in local operation. There are also 3 frequency converter status indicator lights in this area.

| Key | Function |
|--------------------|---|
| 10 Back | Reverts to the previous step or list in the menu structure. |
| 11 Cancel | Cancels the last change or command as long as the display mode has not changed. |
| 12 Info | Press for a definition of the function being displayed. |
| 13 Navigation Keys | Use the 4 navigation keys to move between items in the menu. |
| 14 OK | Use to access parameter groups or to enable a selection. |

Table 5.3 Legend to Illustration 5.1, Navigation Keys

| Indicator | Light | Function |
|-----------|--------|---|
| 15 On | Green | The ON light activates when the frequency converter receives power from the mains voltage, a DC bus terminal, or an external 24 V supply. |
| 16 Warn | Yellow | When warning conditions are met, the yellow WARN light comes on and text appears in the display area identifying the problem. |
| 17 Alarm | Red | A fault condition causes the red alarm light to flash and an alarm text is displayed. |

Table 5.4 Legend to Illustration 5.1, Indicator Lights (LEDs)

D. Operation keys and reset

Operation keys are located at the bottom of the LCP.

| | Key | Function |
|----|---------|--|
| 18 | Hand On | Starts the frequency converter in local control. <ul style="list-style-type: none"> An external stop signal by control input or serial communication overrides the local hand on. |
| 19 | Off | Stops the motor but does not remove power to the frequency converter. |
| 20 | Auto On | Puts the system in remote operational mode. <ul style="list-style-type: none"> Responds to an external start command by control terminals or serial communication. |
| 21 | Reset | Resets the frequency converter manually after a fault has been cleared. |

Table 5.5 Legend to *Illustration 5.1, Operation Keys and Reset*

NOTICE

The display contrast can be adjusted by pressing [Status] and the [▲]/[▼] keys.

5.3.3 Parameter Settings

Establishing the correct programming for applications often requires setting functions in several related parameters. Details for parameters are provided in *chapter 9.2 Parameter Menu Structure*.

Programming data is stored internally in the frequency converter.

- For back-up, upload data into the LCP memory.
- To download data to another frequency converter, connect the LCP to that unit and download the stored settings.
- Restoring factory default settings does not change data stored in the LCP memory.

5.3.4 Uploading/Downloading Data to/from the LCP

- Press [Off] to stop the motor before uploading or downloading data.
- Press [Main Menu] 0-50 LCP Copy and press [OK].
- Select [1] All to LCP to upload data to the LCP or select [2] All from LCP to download data from the LCP.
- Press [OK]. A progress bar shows the uploading or downloading progress.
- Press [Hand On] or [Auto On] to return to normal operation.

5.3.5 Changing Parameter Settings

Parameter settings can be accessed and changed from the Quick Menu or from the Main Menu. The Quick Menu only gives access to a limited number of parameters.

- Press [Quick Menu] or [Main Menu] on the LCP.
- Press [▲] [▼] to browse through the parameter groups, press [OK] to select a parameter group.
- Press [▲] [▼] to browse through the parameters, press [OK] to select a parameter.
- Press [▲] [▼] to change the value of a parameter setting.
- Press [◀] [▶] to shift digit when a decimal parameter is in the editing state.
- Press [OK] to accept the change.
- Press either [Back] twice to enter Status, or press [Main Menu] once to enter the Main Menu.

View changes

Quick Menu Q5 - Changes Made lists all parameters changed from default settings.

- The list only shows parameters, which have been changed in the current edit set-up.
- Parameters, which have been reset to default values, are not listed.
- The message *Empty* indicates that no parameters have been changed.

5.3.6 Restoring Default Settings

NOTICE

Risk of losing programming, motor data, localisation, and monitoring records by restoration of default settings. To provide a back-up, upload data to the LCP before initialisation.

Restoring the default parameter settings is done by initialisation of the frequency converter. Initialisation is carried out through *14-22 Operation Mode* (recommended) or manually.

- Initialisation using *14-22 Operation Mode* does not reset frequency converter settings, such as operating hours, serial communication selections, personal menu settings, fault log, alarm log, and other monitoring functions.
- Manual initialisation erases all motor, programming, localisation, and monitoring data and restores factory default settings.

Recommended initialisation procedure, via 14-22 Operation Mode

1. Press [Main Menu] twice to access parameters.
2. Scroll to 14-22 Operation Mode and press [OK].
3. Scroll to [2] Initialisation and press [OK].
4. Remove power to the unit and wait for the display to turn off.
5. Apply power to the unit.

Default parameter settings are restored during start-up. This may take slightly longer than normal.

6. Alarm 80 is displayed.
7. Press [Reset] to return to operation mode.

Manual initialisation procedure

1. Remove power to the unit and wait for the display to turn off.
2. Press and hold [Status], [Main Menu], and [OK] at the same time while applying power to the unit (approximately 5 s or until audible click and fan starts).

Factory default parameter settings are restored during start-up. This may take slightly longer than normal.

Manual initialisation does not reset the following frequency converter information:

- 15-00 Operating hours.
- 15-03 Power Up's.
- 15-04 Over Temp's.
- 15-05 Over Volt's.

5.4 Basic Programming

5.4.1 Commissioning with SmartStart

The SmartStart wizard enables fast configuration of basic motor and application parameters.

- SmartStart starts automatically, at first power up or after initialisation of the frequency converter.
- Follow the on-screen instructions to complete the commissioning of the frequency converter. Always reactivate SmartStart by selecting *Quick Menu Q4 - SmartStart*.
- For commissioning without use of the SmartStart wizard, refer to *chapter 5.4.2 Commissioning via [Main Menu]* or the programming guide.

NOTICE

Motor data is required for the SmartStart set-up. The required data is normally available on the motor nameplate.

The SmartStart configures the frequency converter in 3 phases, each consisting of several steps, see *Table 5.6*.

| Phase | | Comment |
|-------|-------------------------|--|
| 1 | Basic Programming | Programme, for example motor data |
| 2 | Application Section | Select and programme appropriate application: <ul style="list-style-type: none"> • Single pump/motor. • Motor alternation. • Basic cascade control. • Master/follower. |
| 3 | Water and Pump Features | Go to water and pump dedicated parameters. |

Table 5.6 SmartStart, Setup in 3 Phases

5.4.2 Commissioning via [Main Menu]

Recommended parameter settings are intended for start-up and check-out purposes. Application settings may vary.

Enter data with power ON, but before operating the frequency converter.

1. Press [Main Menu] on the LCP.
2. Press the navigation keys to scroll to parameter group 0-** Operation/Display and press [OK].

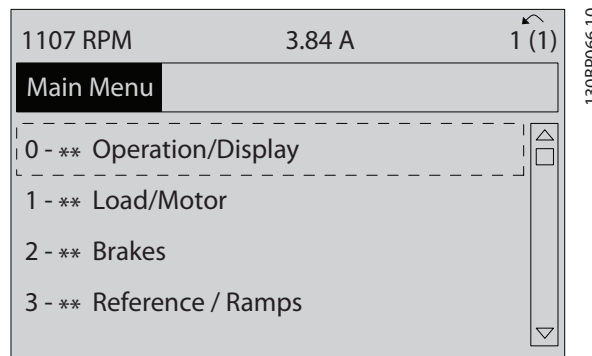

Illustration 5.2 Main Menu

- Press the navigation keys to scroll to parameter group 0-0* *Basic Settings* and press [OK].

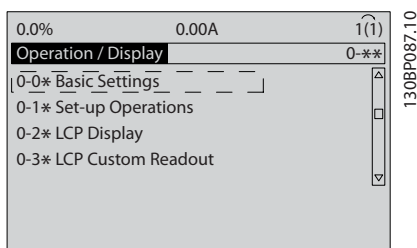

Illustration 5.3 Operation/Display

- Press the navigation keys to scroll to 0-03 *Regional Settings* and press [OK].

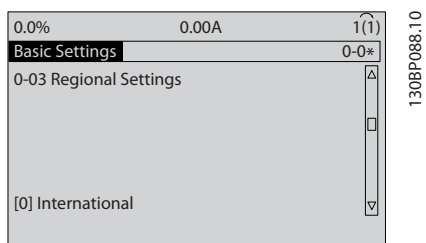

Illustration 5.4 Basic Settings

- Press the navigation keys to select [0] *International* or [1] *North America* as appropriate and press [OK]. (This changes the default settings for a number of basic parameters).
- Press [Main Menu] on the LCP.
- Press the navigation keys to scroll to 0-01 *Language*.
- Select the language and press [OK].
- If a jumper wire is in place between control terminals 12 and 27, leave 5-12 *Terminal 27 Digital Input* at factory default. Otherwise, select *No Operation* in 5-12 *Terminal 27 Digital Input*.
- Make the application specific settings in the following parameters:
 - 3-02 *Minimum Reference*.
 - 3-03 *Maximum Reference*.
 - 3-41 *Ramp 1 Ramp Up Time*.
 - 3-42 *Ramp 1 Ramp Down Time*.
 - 3-13 *Reference Site*. Linked to Hand/Auto Local Remote.

5.4.3 Asynchronous Motor Set-up

Enter the following motor data. The information can be found on the motor nameplate.

- 1-20 *Motor Power [kW]* or 1-21 *Motor Power [HP]*.
- 1-22 *Motor Voltage*.
- 1-23 *Motor Frequency*.
- 1-24 *Motor Current*.
- 1-25 *Motor Nominal Speed*.

When running in flux mode, or for optimum performance in VVC+ mode, extra motor data is required to set up the following parameters. The data can be found in the motor data sheet (this data is typically not available on the motor name plate). Run a complete AMA using 1-29 *Automatic Motor Adaptation (AMA) [1] Enable Complete AMA* or enter the parameters manually. 1-36 *Iron Loss Resistance (Rfe)* is always entered manually.

- 1-30 *Stator Resistance (Rs)*.
- 1-31 *Rotor Resistance (Rr)*.
- 1-33 *Stator Leakage Reactance (X1)*.
- 1-34 *Rotor Leakage Reactance (X2)*.
- 1-35 *Main Reactance (Xh)*.
- 1-36 *Iron Loss Resistance (Rfe)*.

Application-specific adjustment when running VVC+

VVC+ is the most robust control mode. In most situations, it provides optimum performance without further adjustments. Run a complete AMA for best performance.

Application-specific adjustment when running Flux

Flux mode is the preferred control mode for optimum shaft performance in dynamic applications. Perform an AMA since this control mode requires precise motor data. Depending on the application, further adjustments may be required.

See Table 5.7 for application-related recommendations.

| Application | Settings |
|---------------------------|---|
| Low-inertia applications | Keep calculated values. |
| High-inertia applications | 1-66 <i>Min. Current at Low Speed</i> . Increase current to a value between default and maximum depending on the application. Set ramp times matching the application. Too fast ramp up causes an overcurrent or overtorque. Too fast ramp down causes an overvoltage trip. |

| Application | Settings |
|------------------------|--|
| High load at low speed | <i>1-66 Min. Current at Low Speed.</i> Increase current to a value between default and maximum depending on the application. |
| No-load application | Adjust <i>1-18 Min. Current at No Load</i> to achieve smoother motor operation by reducing torque ripple and vibration. |
| Flux sensorless only | Adjust <i>1-53 Model Shift Frequency</i> . Example 1: If the motor oscillates at 5 Hz and dynamics performance is required at 15 Hz, set <i>1-53 Model Shift Frequency</i> to 10 Hz. Example 2: If the application involves dynamic load changes at low speed, reduce <i>1-53 Model Shift Frequency</i> . Observe the motor behaviour to make sure that the model shift frequency is not reduced too much. Symptoms of inappropriate model shift frequency are motor oscillations or frequency converter tripping. |

Table 5.7 Recommendations for Flux Applications

5.4.4 PM Motor Setup in VVC⁺

NOTICE

Only use permanent magnet (PM) motor with fans and pumps.

Initial programming steps

1. Activate PM motor operation *1-10 Motor Construction*, select [1] PM, non salient SPM.
2. Set *0-02 Motor Speed Unit* to [0] RPM.

Programming motor data

After selecting PM motor in *1-10 Motor Construction*, the PM motor-related parameters in parameter groups *1-2** Motor Data, *1-3** Adv. Motor Data and *1-4** are active. The necessary data can be found on the motor nameplate and in the motor data sheet.

Programme the following parameters in the listed order:

1. *1-24 Motor Current.*
2. *1-26 Motor Cont. Rated Torque.*
3. *1-25 Motor Nominal Speed.*
4. *1-39 Motor Poles.*
5. *1-30 Stator Resistance (Rs).*
Enter line to common stator winding resistance (Rs). If only line-line data is available, divide the line-line value with 2 to achieve the line to common (starpoint) value.

6. *1-37 d-axis Inductance (Ld).*
Enter line to common direct axis inductance of the PM motor.
If only line-line data is available, divide the line-line value by 2 to achieve the line-common (starpoint) value.
7. *1-40 Back EMF at 1000 RPM.*
Enter line-to-line back EMF of the PM motor at 1000 RPM mechanical speed (RMS value). Back EMF is the voltage generated by a PM motor when no frequency converter is connected and the shaft is turned externally. Back EMF is normally specified for nominal motor speed or for 1000 RPM measured between 2 lines. If the value is not available for a motor speed of 1000 RPM, calculate the correct value as follows: If back EMF is for example 320 V at 1800 RPM, it can be calculated at 1000 RPM as follows: Back EMF = (Voltage / RPM)*1000 = (320/1800)*1000 = 178. This is the value that must be programmed for *1-40 Back EMF at 1000 RPM.*

Test Motor Operation

1. Start the motor at low speed (100–200 RPM). If the motor does not turn, check installation, general programming, and motor data.
2. Check if the start function in *1-70 PM Start Mode* fits the application requirements.

Rotor detection

This function is the recommended choice for applications where the motor starts from standstill, for example pumps or conveyors. On some motors, an acoustic sound is heard when the impulse is sent out. This does not harm the motor.

Parking

This function is the recommended choice for applications where the motor is rotating at slow speed, for example windmilling in fan applications. *2-06 Parking Current* and *2-07 Parking Time* can be adjusted. Increase the factory setting of these parameters for applications with high inertia.

Start the motor at nominal speed. If the application does not run well, check the VVC⁺ PM settings. Recommendations in different applications can be found in *Table 5.7*.

| Application | Settings |
|---|--|
| Low inertia applications $I_{Load}/I_{Motor} < 5$ | 1-17 Voltage filter time const. to be increased by factor 5–10. 1-14 Damping Gain should be reduced. 1-66 Min. Current at Low Speed should be reduced (<100%). |
| Low inertia applications $50 > I_{Load}/I_{Motor} > 5$ | Keep calculated values. |
| High inertia applications $I_{Load}/I_{Motor} > 50$ | 1-14 Damping Gain, 1-15 Low Speed Filter Time Const., and 1-16 High Speed Filter Time Const. should be increased. |
| High load at low speed <30% (rated speed) | 1-17 Voltage filter time const. should be increased. 1-66 Min. Current at Low Speed should be increased (>100% for a prolonged time can overheat the motor). |

Table 5.8 Recommendations in Different Applications

If the motor starts oscillating at a certain speed, increase 1-14 Damping Gain. Increase the value in small steps. Depending on the motor, a good value for this parameter can be 10% or 100% higher than the default value.

The starting torque can be adjusted in 1-66 Min. Current at Low Speed. 100% provides nominal torque as starting torque.

5.4.5 SynRM Motor Set-up with VVC+

This section describes how to set up a SynRM motor with VVC+.

NOTICE

The SmartStart wizard covers the basic configuration of SynRM motors.

Initial programming steps

To activate SynRM motor operation, select [5] Sync. Reluctance in 1-10 Motor Construction.

Programming motor data

After performing the initial programming steps, the SynRM motor-related parameters in parameter groups 1-2* Motor Data, 1-3* Adv. Motor Data, and 1-4* Adv. Motor Data II are active. Use the motor nameplate data and the motor data sheet to programme the following parameters in the order listed:

- 1-23 Motor Frequency.
- 1-24 Motor Current.
- 1-25 Motor Nominal Speed.
- 1-26 Motor Cont. Rated Torque.

Run a complete AMA using 1-29 Automatic Motor Adaptation (AMA) [1] Enable Complete AMA or enter the following parameters manually:

- 1-30 Stator Resistance (Rs).
- 1-37 d-axis Inductance (Ld).
- 1-44 d-axis Inductance (Ld) 200% Inom.
- 1-45 q-axis Inductance (Lq) 200% Inom.
- 1-48 Inductance Sat. Point.

Application-specific adjustments

Start the motor at nominal speed. If the application does not run well, check the VVC+ SynRM settings. Table 5.9 provides application-specific recommendations:

| Application | Settings |
|---|--|
| Low-inertia applications $I_{Load}/I_{Motor} < 5$ | Increase 1-17 Voltage filter time const. by factor 5 to 10. Reduce 1-14 Damping Gain. Reduce 1-66 Min. Current at Low Speed (<100%). |
| Low-inertia applications $50 > I_{Load}/I_{Motor} > 5$ | Keep the default values. |
| High-inertia applications $I_{Load}/I_{Motor} > 50$ | Increase 1-14 Damping Gain, 1-15 Low Speed Filter Time Const., and 1-16 High Speed Filter Time Const. |
| High-load at low speed <30% (rated speed) | Increase 1-17 Voltage filter time const. Increase 1-66 Min. Current at Low Speed to adjust the starting torque. 100% current provides nominal torque as starting torque. This parameter is independent of 30-20 High Starting Torque Time [s] and 30-21 High Starting Torque Current [%]. Working at a current level higher than 100% for a prolonged time can cause the motor to overheat. |
| Dynamic applications | Increase 14-41 AEO Minimum Magnetisation for highly dynamic applications. Adjusting 14-41 AEO Minimum Magnetisation ensures a good balance between energy efficiency and dynamics. Adjust 14-42 Minimum AEO Frequency to specify the minimum frequency at which the frequency converter should use minimum magnetisation. |

Table 5.9 Recommendations for Various Applications

If the motor starts oscillating at a certain speed, increase 1-14 Damping Gain. Increase the damping gain value in small steps. Depending on the motor, this parameter can be set to 10–100% higher than the default value.

5.4.6 Automatic Energy Optimisation (AEO)

NOTICE

AEO is not relevant for permanent magnet motors.

AEO is a procedure which minimises voltage to the motor, thereby reducing energy consumption, heat, and noise.

To activate AEO, set *1-03 Torque Characteristics* to *[2] Auto Energy Optim. CT* or *[3] Auto Energy Optim. VT*.

5.4.7 Automatic Motor Adaptation (AMA)

AMA is a procedure which optimises compatibility between the frequency converter and the motor.

- The frequency converter builds a mathematical model of the motor for regulating output motor current. The procedure also tests the input phase balance of electrical power. It compares the motor characteristics with the entered nameplate data.
- The motor shaft does not turn and no harm is done to the motor while running the AMA.
- Some motors may be unable to run the complete version of the test. In that case, select *[2] Enable reduced AMA*.
- If an output filter is connected to the motor, select *[2] Enable reduced AMA*.
- If warnings or alarms occur, see *chapter 7.4 List of Warnings and Alarms*.
- Run this procedure on a cold motor for best results.

To run AMA

1. Press [Main Menu] to access parameters.
2. Scroll to parameter group *1-** Load and Motor* and press [OK].
3. Scroll to parameter group *1-2* Motor Data* and press [OK].
4. Scroll to *1-29 Automatic Motor Adaptation (AMA)* and press [OK].
5. Select *[1] Enable complete AMA* and press [OK].
6. Follow the on-screen instructions.
7. The test runs automatically and indicates when it is complete.
8. The advanced motor data is entered in parameter group *1-3* Adv. Motor Data*.

5.5 Checking Motor Rotation

NOTICE

Risk of damage to pumps/compressors caused by motor running in wrong direction. Before running the frequency converter, check the motor rotation.

The motor runs briefly at 5 Hz or the minimum frequency set in *4-12 Motor Speed Low Limit [Hz]*.

1. Press [Main Menu].
2. Scroll to *1-28 Motor Rotation Check* and press [OK].
3. Scroll to *[1] Enable*.

The following text appears: *Note! Motor may run in wrong direction*.

4. Press [OK].
5. Follow the on-screen instructions.

NOTICE

To change the direction of rotation, remove power to the frequency converter and wait for power to discharge. Reverse the connection of any 2 of the 3 motor wires on the motor or frequency converter side of the connection.

5.6 Local-control Test

1. Press [Hand On] to provide a local start command to the frequency converter.
2. Accelerate the frequency converter by pressing [▲] to full speed. Moving the cursor left of the decimal point provides quicker input changes.
3. Note any acceleration problems.
4. Press [Off]. Note any deceleration problems.

In the event of acceleration or deceleration problems, see *chapter 7.5 Troubleshooting*. See *chapter 7.4 List of Warnings and Alarms* for resetting the frequency converter after a trip.

5.7 System Start-up

The procedure in this section requires user-wiring and application programming to be completed. The following procedure is recommended after application set-up is completed.

1. Press [Auto On].
2. Apply an external run command.
3. Adjust the speed reference throughout the speed range.
4. Remove the external run command.
5. Check the sound and vibration levels of the motor to ensure that the system is working as intended.

If warnings or alarms occur, see *chapter 7.3 Warning and Alarm Types* or *chapter 7.4 List of Warnings and Alarms*.

6 Application Set-up Examples

The examples in this section are intended as a quick reference for common applications.

- Parameter settings are the regional default values unless otherwise indicated (selected in 0-03 Regional Settings).
- Parameters associated with the terminals and their settings are shown next to the drawings.
- Required switch settings for analog terminals A53 or A54 are also shown.

NOTICE

When using the optional STO feature, a jumper wire may be required between terminal 12 (or 13) and terminal 37 for the frequency converter to operate with factory default programming values.

6.1 Application Examples

6.1.1 Feedback

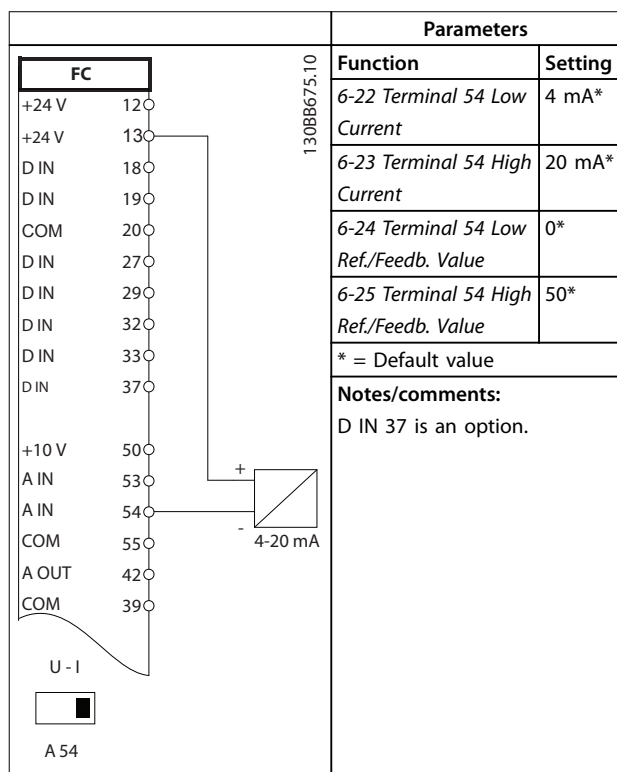

Table 6.1 Analog Current Feedback Transducer

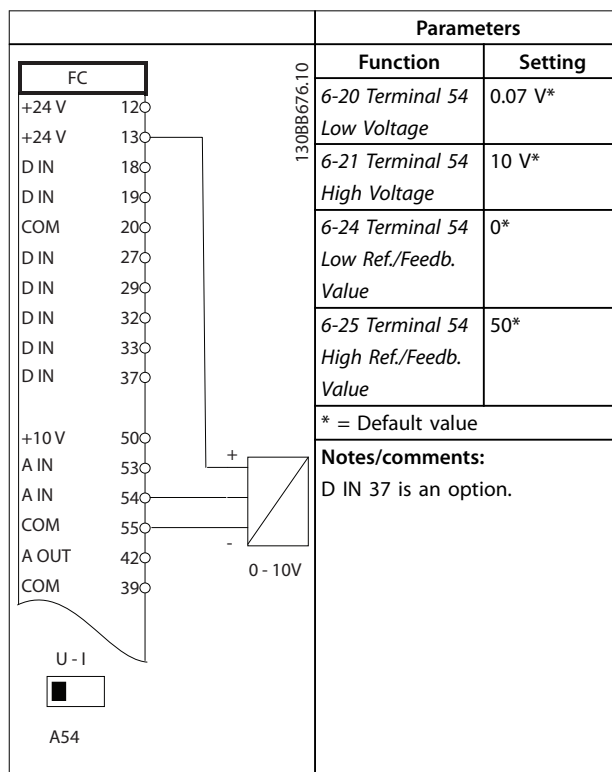

Table 6.2 Analog Voltage Feedback Transducer (3-wire)

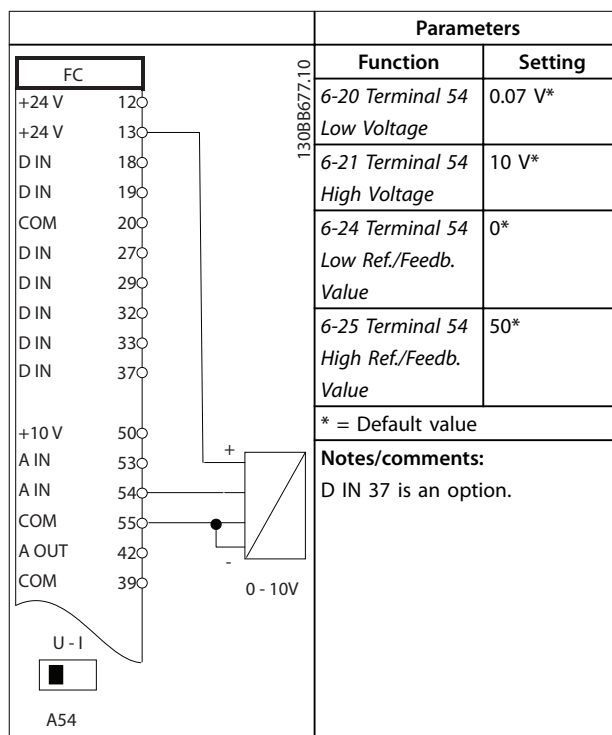

Table 6.3 Analog Voltage Feedback Transducer (4-wire)

6.1.2 Speed

| | | Parameters | |
|-------|----|--|---------|
| FC | | Function | Setting |
| +24 V | 12 | 6-10 Terminal 53 | 0.07 V* |
| +24 V | 13 | Low Voltage | |
| D IN | 18 | 6-11 Terminal 53 | 10 V* |
| D IN | 19 | High Voltage | |
| COM | 20 | 6-14 Terminal 53 | 0 Hz |
| D IN | 27 | Low Ref./Feedb. Value | |
| D IN | 29 | 6-15 Terminal 53 | 50 Hz |
| D IN | 32 | High Ref./Feedb. Value | |
| D IN | 33 | * = Default value | |
| D IN | 37 | Notes/comments: D IN 37 is an option. | |
| +10 V | 50 | | |
| A IN | 53 | | |
| A IN | 54 | | |
| COM | 55 | | |
| A OUT | 42 | | |
| COM | 39 | | |
| A53 | | | |

Table 6.4 Analog Speed Reference (Voltage)

| | | Parameters | |
|-------|----|--|---------|
| FC | | Function | Setting |
| +24 V | 12 | 6-12 Terminal 53 | 4 mA* |
| +24 V | 13 | Low Current | |
| D IN | 18 | 6-13 Terminal 53 | 20 mA* |
| D IN | 19 | High Current | |
| COM | 20 | 6-14 Terminal 53 | 0 Hz |
| D IN | 27 | Low Ref./Feedb. Value | |
| D IN | 29 | 6-15 Terminal 53 | 50 Hz |
| D IN | 32 | High Ref./Feedb. Value | |
| D IN | 33 | * = Default value | |
| D IN | 37 | Notes/comments: D IN 37 is an option. | |
| +10 V | 50 | | |
| A IN | 53 | | |
| A IN | 54 | | |
| COM | 55 | | |
| A OUT | 42 | | |
| COM | 39 | | |
| A53 | | | |

Table 6.5 Analog Speed Reference (Current)

| | | Parameters | |
|-------|----|--|---------|
| FC | | Function | Setting |
| +24 V | 12 | 6-10 Terminal 53 | 0.07 V* |
| +24 V | 13 | Low Voltage | |
| D IN | 18 | 6-11 Terminal 53 | 10 V* |
| D IN | 19 | High Voltage | |
| COM | 20 | 6-14 Terminal 53 | 0 Hz |
| D IN | 27 | Low Ref./Feedb. Value | |
| D IN | 29 | 6-15 Terminal 53 | 50 Hz |
| D IN | 32 | High Ref./Feedb. Value | |
| D IN | 33 | * = Default value | |
| D IN | 37 | Notes/comments: D IN 37 is an option. | |
| +10 V | 50 | | |
| A IN | 53 | | |
| A IN | 54 | | |
| COM | 55 | | |
| A OUT | 42 | | |
| COM | 39 | | |
| A53 | | | |

Table 6.6 Speed Reference (Using a Manual Potentiometer)

6.1.3 Run/Stop

| | | Parameters | |
|-------|----|--|------------------------|
| FC | | Function | Setting |
| +24 V | 12 | 5-10 Terminal 18 | [8] Start* |
| +24 V | 13 | Digital Input | |
| D IN | 18 | 5-12 Terminal 27 | [7] External interlock |
| D IN | 19 | Digital Input | |
| COM | 20 | * = Default value | |
| D IN | 27 | Notes/comments: D IN 37 is an option. | |
| D IN | 29 | | |
| D IN | 32 | | |
| D IN | 33 | | |
| D IN | 37 | | |
| D IN | 37 | | |
| +10 V | 50 | | |
| A IN | 53 | | |
| A IN | 54 | | |
| COM | 55 | | |
| A OUT | 42 | | |
| COM | 39 | | |

Table 6.7 Run/Stop Command with External Interlock

| | | Parameters | |
|-------|----|---|------------------------|
| FC | | Function | Setting |
| +24 V | 12 | 5-10 Terminal 18 | [8] Start* |
| +24 V | 13 | Digital Input | |
| D IN | 18 | 5-12 Terminal 27 | [7] External interlock |
| D IN | 19 | Digital Input | |
| COM | 20 | * = Default value | |
| D IN | 27 | Notes/comments: | |
| D IN | 29 | If 5-12 Terminal 27 Digital Input is set to [0] no operation, a jumper wire to terminal 27 is not needed. | |
| D IN | 32 | D IN 37 is an option. | |
| D IN | 33 | | |
| D IN | 37 | | |
| +10 V | 50 | | |
| A IN | 53 | | |
| A IN | 54 | | |
| COM | 55 | | |
| A OUT | 42 | | |
| COM | 39 | | |
| R1 | 01 | | |
| | 02 | | |
| | 03 | | |
| R2 | 04 | | |
| | 05 | | |
| | 06 | | |

Table 6.8 Run/Stop Command without External Interlock

6.1.4 External Alarm Reset

| | | Parameters | |
|-------|----|------------------------|-----------|
| FC | | Function | Setting |
| +24 V | 12 | 5-11 Terminal 19 | [1] Reset |
| +24 V | 13 | Digital Input | |
| D IN | 18 | * = Default Value | |
| D IN | 19 | Notes/comments: | |
| COM | 20 | D IN 37 is an option. | |
| D IN | 27 | | |
| D IN | 29 | | |
| D IN | 32 | | |
| D IN | 33 | | |
| D IN | 37 | | |
| +10 V | 50 | | |
| A IN | 53 | | |
| A IN | 54 | | |
| COM | 55 | | |
| A OUT | 42 | | |
| COM | 39 | | |

Table 6.10 External Alarm Reset

| | | Parameters | |
|-------|----|------------------------|--------------------------|
| FC | | Function | Setting |
| +24 V | 12 | 5-10 Terminal 18 | [8] Start* |
| +24 V | 13 | Digital Input | |
| D IN | 18 | 5-11 Terminal 19 | [52] Run Permissive |
| D IN | 19 | Digital Input | |
| COM | 20 | 5-12 Terminal 27 | [7] External interlock |
| D IN | 27 | Digital Input | |
| D IN | 29 | 5-40 Function Relay | [167] Start command act. |
| D IN | 32 | * = Default value | |
| D IN | 33 | Notes/comments: | |
| D IN | 37 | D IN 37 is an option. | |
| +10 V | 50 | | |
| A IN | 53 | | |
| A IN | 54 | | |
| COM | 55 | | |
| A OUT | 42 | | |
| COM | 39 | | |
| R1 | 01 | | |
| | 02 | | |
| | 03 | | |
| R2 | 04 | | |
| | 05 | | |
| | 06 | | |

Table 6.9 Run Permissive

6.1.5 RS485

| | | Parameters | | | | | | | | | | | | | | | | | | | | | | | | | | | | | | | | | | | | | | | | | | | | | | | | | | | | | | | | | | | | | |
|---|----|------------|---------|-------|----|-------|----|------|----|------|----|-----|----|------|----|------|----|------|----|------|----|------|----|--|--|-------|----|------|----|------|----|-----|----|-------|----|-----|----|--|--|----|----|--|----|--|----|--|--|----|----|--|----|--|----|--|--|--|----|--|----|--|----|-------------|---|
| | | Function | Setting | | | | | | | | | | | | | | | | | | | | | | | | | | | | | | | | | | | | | | | | | | | | | | | | | | | | | | | | | | | | |
| <table border="1"> <thead> <tr> <th colspan="2">FC</th> </tr> </thead> <tbody> <tr><td>+24 V</td><td>12</td></tr> <tr><td>+24 V</td><td>13</td></tr> <tr><td>D IN</td><td>18</td></tr> <tr><td>D IN</td><td>19</td></tr> <tr><td>COM</td><td>20</td></tr> <tr><td>D IN</td><td>27</td></tr> <tr><td>D IN</td><td>29</td></tr> <tr><td>D IN</td><td>32</td></tr> <tr><td>D IN</td><td>33</td></tr> <tr><td>D IN</td><td>37</td></tr> <tr><td colspan="2"> </td></tr> <tr><td>+10 V</td><td>50</td></tr> <tr><td>A IN</td><td>53</td></tr> <tr><td>A IN</td><td>54</td></tr> <tr><td>COM</td><td>55</td></tr> <tr><td>A OUT</td><td>42</td></tr> <tr><td>COM</td><td>39</td></tr> <tr><td colspan="2"> </td></tr> <tr><td>R1</td><td>01</td></tr> <tr><td></td><td>02</td></tr> <tr><td></td><td>03</td></tr> <tr><td colspan="2"> </td></tr> <tr><td>R2</td><td>04</td></tr> <tr><td></td><td>05</td></tr> <tr><td></td><td>06</td></tr> <tr><td colspan="2"> </td></tr> <tr><td></td><td>61</td></tr> <tr><td></td><td>68</td></tr> <tr><td></td><td>69</td></tr> </tbody> </table> | | FC | | +24 V | 12 | +24 V | 13 | D IN | 18 | D IN | 19 | COM | 20 | D IN | 27 | D IN | 29 | D IN | 32 | D IN | 33 | D IN | 37 | | | +10 V | 50 | A IN | 53 | A IN | 54 | COM | 55 | A OUT | 42 | COM | 39 | | | R1 | 01 | | 02 | | 03 | | | R2 | 04 | | 05 | | 06 | | | | 61 | | 68 | | 69 | 130BB685.10 | 8-30 Protocol FC* 8-31 Address 1* 8-32 Baud Rate 9600* * = Default Value Notes/comments: Select protocol, address and baud rate in the above mentioned parameters. D IN 37 is an option. |
| FC | | | | | | | | | | | | | | | | | | | | | | | | | | | | | | | | | | | | | | | | | | | | | | | | | | | | | | | | | | | | | | | |
| +24 V | 12 | | | | | | | | | | | | | | | | | | | | | | | | | | | | | | | | | | | | | | | | | | | | | | | | | | | | | | | | | | | | | | |
| +24 V | 13 | | | | | | | | | | | | | | | | | | | | | | | | | | | | | | | | | | | | | | | | | | | | | | | | | | | | | | | | | | | | | | |
| D IN | 18 | | | | | | | | | | | | | | | | | | | | | | | | | | | | | | | | | | | | | | | | | | | | | | | | | | | | | | | | | | | | | | |
| D IN | 19 | | | | | | | | | | | | | | | | | | | | | | | | | | | | | | | | | | | | | | | | | | | | | | | | | | | | | | | | | | | | | | |
| COM | 20 | | | | | | | | | | | | | | | | | | | | | | | | | | | | | | | | | | | | | | | | | | | | | | | | | | | | | | | | | | | | | | |
| D IN | 27 | | | | | | | | | | | | | | | | | | | | | | | | | | | | | | | | | | | | | | | | | | | | | | | | | | | | | | | | | | | | | | |
| D IN | 29 | | | | | | | | | | | | | | | | | | | | | | | | | | | | | | | | | | | | | | | | | | | | | | | | | | | | | | | | | | | | | | |
| D IN | 32 | | | | | | | | | | | | | | | | | | | | | | | | | | | | | | | | | | | | | | | | | | | | | | | | | | | | | | | | | | | | | | |
| D IN | 33 | | | | | | | | | | | | | | | | | | | | | | | | | | | | | | | | | | | | | | | | | | | | | | | | | | | | | | | | | | | | | | |
| D IN | 37 | | | | | | | | | | | | | | | | | | | | | | | | | | | | | | | | | | | | | | | | | | | | | | | | | | | | | | | | | | | | | | |
| | | | | | | | | | | | | | | | | | | | | | | | | | | | | | | | | | | | | | | | | | | | | | | | | | | | | | | | | | | | | | | | |
| +10 V | 50 | | | | | | | | | | | | | | | | | | | | | | | | | | | | | | | | | | | | | | | | | | | | | | | | | | | | | | | | | | | | | | |
| A IN | 53 | | | | | | | | | | | | | | | | | | | | | | | | | | | | | | | | | | | | | | | | | | | | | | | | | | | | | | | | | | | | | | |
| A IN | 54 | | | | | | | | | | | | | | | | | | | | | | | | | | | | | | | | | | | | | | | | | | | | | | | | | | | | | | | | | | | | | | |
| COM | 55 | | | | | | | | | | | | | | | | | | | | | | | | | | | | | | | | | | | | | | | | | | | | | | | | | | | | | | | | | | | | | | |
| A OUT | 42 | | | | | | | | | | | | | | | | | | | | | | | | | | | | | | | | | | | | | | | | | | | | | | | | | | | | | | | | | | | | | | |
| COM | 39 | | | | | | | | | | | | | | | | | | | | | | | | | | | | | | | | | | | | | | | | | | | | | | | | | | | | | | | | | | | | | | |
| | | | | | | | | | | | | | | | | | | | | | | | | | | | | | | | | | | | | | | | | | | | | | | | | | | | | | | | | | | | | | | | |
| R1 | 01 | | | | | | | | | | | | | | | | | | | | | | | | | | | | | | | | | | | | | | | | | | | | | | | | | | | | | | | | | | | | | | |
| | 02 | | | | | | | | | | | | | | | | | | | | | | | | | | | | | | | | | | | | | | | | | | | | | | | | | | | | | | | | | | | | | | |
| | 03 | | | | | | | | | | | | | | | | | | | | | | | | | | | | | | | | | | | | | | | | | | | | | | | | | | | | | | | | | | | | | | |
| | | | | | | | | | | | | | | | | | | | | | | | | | | | | | | | | | | | | | | | | | | | | | | | | | | | | | | | | | | | | | | | |
| R2 | 04 | | | | | | | | | | | | | | | | | | | | | | | | | | | | | | | | | | | | | | | | | | | | | | | | | | | | | | | | | | | | | | |
| | 05 | | | | | | | | | | | | | | | | | | | | | | | | | | | | | | | | | | | | | | | | | | | | | | | | | | | | | | | | | | | | | | |
| | 06 | | | | | | | | | | | | | | | | | | | | | | | | | | | | | | | | | | | | | | | | | | | | | | | | | | | | | | | | | | | | | | |
| | | | | | | | | | | | | | | | | | | | | | | | | | | | | | | | | | | | | | | | | | | | | | | | | | | | | | | | | | | | | | | | |
| | 61 | | | | | | | | | | | | | | | | | | | | | | | | | | | | | | | | | | | | | | | | | | | | | | | | | | | | | | | | | | | | | | |
| | 68 | | | | | | | | | | | | | | | | | | | | | | | | | | | | | | | | | | | | | | | | | | | | | | | | | | | | | | | | | | | | | | |
| | 69 | | | | | | | | | | | | | | | | | | | | | | | | | | | | | | | | | | | | | | | | | | | | | | | | | | | | | | | | | | | | | | |

Table 6.11 RS485 Network Connection

6.1.6 Motor Thermistor



WARNING

THERMISTOR INSULATION
Risk of personal injury or equipment damage.

- Use only thermistors with reinforced or double insulation to meet PELV insulation requirements.

| | | Parameters | | | | | | | | | | | | | | | | | | | | | | | | | | | | | | | | | | | | | | | | | | | |
|--|-------|------------|---------|-------|----|-------|----|------|----|------|----|-----|----|------|----|------|----|------|----|------|----|------|----|--|--|-------|----|------|----|------|----|-----|----|-------|----|-----|----|--|--|--|-------|--|-----|-------------|---|
| | | Function | Setting | | | | | | | | | | | | | | | | | | | | | | | | | | | | | | | | | | | | | | | | | | |
| <table border="1"> <thead> <tr> <th colspan="2">VLT</th> </tr> </thead> <tbody> <tr><td>+24 V</td><td>12</td></tr> <tr><td>+24 V</td><td>13</td></tr> <tr><td>D IN</td><td>18</td></tr> <tr><td>D IN</td><td>19</td></tr> <tr><td>COM</td><td>20</td></tr> <tr><td>D IN</td><td>27</td></tr> <tr><td>D IN</td><td>29</td></tr> <tr><td>D IN</td><td>32</td></tr> <tr><td>D IN</td><td>33</td></tr> <tr><td>D IN</td><td>37</td></tr> <tr><td colspan="2"> </td></tr> <tr><td>+10 V</td><td>50</td></tr> <tr><td>A IN</td><td>53</td></tr> <tr><td>A IN</td><td>54</td></tr> <tr><td>COM</td><td>55</td></tr> <tr><td>A OUT</td><td>42</td></tr> <tr><td>COM</td><td>39</td></tr> <tr><td colspan="2"> </td></tr> <tr><td></td><td>U - I</td></tr> <tr><td></td><td>A53</td></tr> </tbody> </table> | | VLT | | +24 V | 12 | +24 V | 13 | D IN | 18 | D IN | 19 | COM | 20 | D IN | 27 | D IN | 29 | D IN | 32 | D IN | 33 | D IN | 37 | | | +10 V | 50 | A IN | 53 | A IN | 54 | COM | 55 | A OUT | 42 | COM | 39 | | | | U - I | | A53 | 130BB686.12 | 1-90 Motor Thermal Protection [2] Thermistor trip 1-93 Thermistor Source [1] Analog input 53 * = Default Value Notes/comments: If only a warning is desired, 1-90 Motor Thermal Protection should be set to [1] Thermistor warning. D IN 37 is an option. |
| VLT | | | | | | | | | | | | | | | | | | | | | | | | | | | | | | | | | | | | | | | | | | | | | |
| +24 V | 12 | | | | | | | | | | | | | | | | | | | | | | | | | | | | | | | | | | | | | | | | | | | | |
| +24 V | 13 | | | | | | | | | | | | | | | | | | | | | | | | | | | | | | | | | | | | | | | | | | | | |
| D IN | 18 | | | | | | | | | | | | | | | | | | | | | | | | | | | | | | | | | | | | | | | | | | | | |
| D IN | 19 | | | | | | | | | | | | | | | | | | | | | | | | | | | | | | | | | | | | | | | | | | | | |
| COM | 20 | | | | | | | | | | | | | | | | | | | | | | | | | | | | | | | | | | | | | | | | | | | | |
| D IN | 27 | | | | | | | | | | | | | | | | | | | | | | | | | | | | | | | | | | | | | | | | | | | | |
| D IN | 29 | | | | | | | | | | | | | | | | | | | | | | | | | | | | | | | | | | | | | | | | | | | | |
| D IN | 32 | | | | | | | | | | | | | | | | | | | | | | | | | | | | | | | | | | | | | | | | | | | | |
| D IN | 33 | | | | | | | | | | | | | | | | | | | | | | | | | | | | | | | | | | | | | | | | | | | | |
| D IN | 37 | | | | | | | | | | | | | | | | | | | | | | | | | | | | | | | | | | | | | | | | | | | | |
| | | | | | | | | | | | | | | | | | | | | | | | | | | | | | | | | | | | | | | | | | | | | | |
| +10 V | 50 | | | | | | | | | | | | | | | | | | | | | | | | | | | | | | | | | | | | | | | | | | | | |
| A IN | 53 | | | | | | | | | | | | | | | | | | | | | | | | | | | | | | | | | | | | | | | | | | | | |
| A IN | 54 | | | | | | | | | | | | | | | | | | | | | | | | | | | | | | | | | | | | | | | | | | | | |
| COM | 55 | | | | | | | | | | | | | | | | | | | | | | | | | | | | | | | | | | | | | | | | | | | | |
| A OUT | 42 | | | | | | | | | | | | | | | | | | | | | | | | | | | | | | | | | | | | | | | | | | | | |
| COM | 39 | | | | | | | | | | | | | | | | | | | | | | | | | | | | | | | | | | | | | | | | | | | | |
| | | | | | | | | | | | | | | | | | | | | | | | | | | | | | | | | | | | | | | | | | | | | | |
| | U - I | | | | | | | | | | | | | | | | | | | | | | | | | | | | | | | | | | | | | | | | | | | | |
| | A53 | | | | | | | | | | | | | | | | | | | | | | | | | | | | | | | | | | | | | | | | | | | | |

Table 6.12 Motor Thermistor

7 Maintenance, Diagnostics and Troubleshooting

This chapter includes maintenance and service guidelines, status messages, warnings and alarms, and basic troubleshooting.

7.1 Maintenance and Service

Under normal operating conditions and load profiles, the frequency converter is maintenance-free throughout its designed lifetime. To prevent breakdown, danger, and damage, examine the frequency converter at regular intervals depending on the operating conditions. Replace worn or damaged parts with original spare parts or standard parts. For service and support, refer to www.danfoss.com/contact/sales_and_services/.

⚠ WARNING

UNINTENDED START

When the frequency converter is connected to AC mains, DC power supply, or load sharing, the motor may start at any time. Unintended start during programming, service, or repair work can result in death, serious injury, or property damage. The motor can start by means of an external switch, a serial bus command, an input reference signal from the LCP or LOP, via remote operation using MCT 10 Set-up Software, or after a cleared fault condition.

7.2 Status Messages

When the frequency converter is in *Status mode*, status messages are generated automatically and appear in the bottom line of the display (see *Illustration 7.1*).

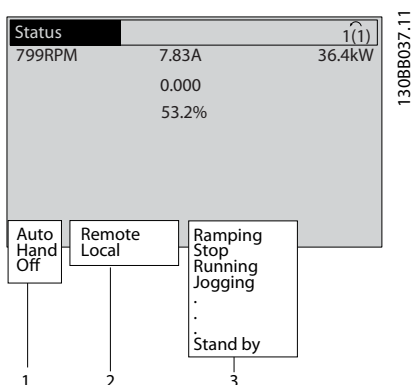

| | |
|---|--|
| 1 | Operation mode (see <i>Table 7.1</i>) |
| 2 | Reference site (see <i>Table 7.2</i>) |
| 3 | Operation status (see <i>Table 7.3</i>) |

Illustration 7.1 Status Display

Table 7.1 to *Table 7.3* describe the displayed status messages.

| | |
|---------|--|
| Off | The frequency converter does not react to any control signal until [Auto On] or [Hand On] is pressed. |
| Auto On | The frequency converter is controlled from the control terminals and/or the serial communication. |
| Hand On | The frequency converter is controlled by the navigation keys on the LCP. Stop commands, reset, reversing, DC brake, and other signals applied to the control terminals override local control. |

Table 7.1 Operation Mode

| | |
|--------|--|
| Remote | The speed reference is given from external signals, serial communication, or internal preset references. |
| Local | The frequency converter uses [Hand On] control or reference values from the LCP. |

Table 7.2 Reference Site

| | |
|-----------------|--|
| AC Brake | AC Brake was selected in <i>2-10 Brake Function</i> . The AC brake overmagnetises the motor to achieve a controlled slow-down. |
| AMA finish OK | Automatic motor adaptation (AMA) was carried out successfully. |
| AMA ready | AMA is ready to start. Press [Hand On] to start. |
| AMA running | AMA process is in progress. |
| Braking | The brake chopper is in operation. Generative energy is absorbed by the brake resistor. |
| Braking max. | The brake chopper is in operation. The power limit for the brake resistor defined in <i>2-12 Brake Power Limit (kW)</i> has been reached. |
| Coast | <ul style="list-style-type: none"> Coast inverse was selected as a function for a digital input (parameter group 5-1* <i>Digital Inputs</i>). The corresponding terminal is not connected. Coast activated by serial communication. |
| Ctrl. ramp-down | <p>[1] <i>Control Ramp-down</i> was selected in <i>14-10 Mains Failure</i>.</p> <ul style="list-style-type: none"> The mains voltage is below the value set in <i>14-11 Mains Voltage at Mains Fault</i> at mains fault The frequency converter ramps down the motor using a controlled ramp down. |

| | |
|-----------------------|--|
| Current High | The frequency converter output current is above the limit set in 4-51 <i>Warning Current High</i> . |
| Current Low | The frequency converter output current is below the limit set in 4-52 <i>Warning Speed Low</i> . |
| DC Hold | [1] <i>DC hold</i> is selected in 1-80 <i>Function at Stop</i> and a stop command is active. The motor is held by a DC current set in 2-00 <i>DC Hold/Preheat Current</i> . |
| DC Stop | The motor is held with a DC current (2-01 <i>DC Brake Current</i>) for a specified time (2-02 <i>DC Braking Time</i>). <ul style="list-style-type: none"> The <i>DC Brake</i> cut in speed is reached in 2-03 <i>DC Brake Cut In Speed [RPM]</i> and a stop command is active. <i>DC Brake</i> (inverse) is selected as a function for a digital input (parameter group 5-1* <i>Digital Inputs</i>). The corresponding terminal is not active. The <i>DC Brake</i> is activated via serial communication. |
| Feedback high | The sum of all active feedbacks is above the feedback limit set in 4-57 <i>Warning Feedback High</i> . |
| Feedback low | The sum of all active feedbacks is below the feedback limit set in 4-56 <i>Warning Feedback Low</i> . |
| Freeze output | The remote reference is active, which holds the present speed. <ul style="list-style-type: none"> <i>Freeze output</i> was selected as a function for a digital input (parameter group 5-1* <i>Digital Inputs</i>). The corresponding terminal is active. Speed control is only possible via the terminal functions <i>Speed Up</i> and <i>Speed Down</i>. <i>Hold ramp</i> is activated via serial communication. |
| Freeze output request | A freeze output command was given, but the motor remains stopped until a run permissive signal is received. |
| Freeze ref. | <i>Freeze Reference</i> was selected as a function for a digital input (parameter group 5-1* <i>Digital Inputs</i>). The corresponding terminal is active. The frequency converter saves the actual reference. Changing the reference is now only possible via terminal functions <i>Speed Up</i> and <i>Speed Down</i> . |
| Jog request | A jog command was given, but the motor remains stopped until a run permissive signal is received via a digital input. |

| | |
|---------------|---|
| Jogging | The motor is running as programmed in 3-19 <i>Jog Speed [RPM]</i> . <ul style="list-style-type: none"> <i>Jog</i> was selected as a function for a digital input (parameter group 5-1* <i>Digital Inputs</i>). The corresponding terminal (for example Terminal 29) is active. The <i>Jog</i> function is activated via the serial communication. The <i>Jog</i> function was selected as a reaction for a monitoring function (for example No signal). The monitoring function is active. |
| Motor check | In 1-80 <i>Function at Stop</i> , [2] <i>Motor Check</i> was selected. A stop command is active. To ensure that a motor is connected to the frequency converter, a permanent test current is applied to the motor. |
| OVC control | Overvoltage control was activated in 2-17 <i>Over-voltage Control</i> , [2] <i>Enabled</i> . The connected motor supplies the frequency converter with generative energy. The overvoltage control adjusts the V/Hz ratio to run the motor in controlled mode and to prevent the frequency converter from tripping. |
| PowerUnit Off | (Only frequency converters with an external 24 V power supply installed). Mains supply to the frequency converter was removed, and the control card is supplied by the external 24 V. |
| Protection md | Protection mode is active. The unit has detected a critical status (overcurrent or overvoltage). <ul style="list-style-type: none"> To avoid tripping, switching frequency is reduced to 4 kHz. If possible, protection mode ends after approximately 10 s. Protection mode can be restricted in 14-26 <i>Trip Delay at Inverter Fault</i>. |
| QStop | The motor is decelerating using 3-81 <i>Quick Stop Ramp Time</i> . <ul style="list-style-type: none"> <i>Quick stop inverse</i> was selected as a function for a digital input (parameter group 5-1* <i>Digital Inputs</i>). The corresponding terminal is not active. The <i>quick stop</i> function was activated via serial communication. |
| Ramping | The motor is accelerating/decelerating using the active ramp up/down. The reference, a limit value, or a standstill is not yet reached. |
| Ref. high | The sum of all active references is above the reference limit set in 4-55 <i>Warning Reference High</i> . |

| | |
|---------------|--|
| Ref. low | The sum of all active references is below the reference limit set in <i>4-54 Warning Reference Low</i> . |
| Run on ref. | The frequency converter is running in the reference range. The feedback value matches the setpoint value. |
| Run request | A start command was given, but the motor remains stopped until a run permissive signal is received via digital input. |
| Running | The motor is driven by the frequency converter. |
| Sleep Mode | The energy-saving function is enabled. The motor has stopped, but restarts automatically when required. |
| Speed high | Motor speed is above the value set in <i>4-53 Warning Speed High</i> . |
| Speed low | Motor speed is below the value set in <i>4-52 Warning Speed Low</i> . |
| Standby | In <i>Auto On</i> mode, the frequency converter starts the motor with a start signal from a digital input or serial communication. |
| Start delay | In <i>1-71 Start Delay</i> , a delay starting time was set. A start command is activated and the motor starts after the start delay time expires. |
| Start fwd/rev | <i>Start forward</i> and <i>start reverse</i> were selected as functions for 2 different digital inputs (parameter group <i>5-1* Digital Inputs</i>). The motor starts in forward or reverse direction depending on which corresponding terminal is activated. |
| Stop | The frequency converter has received a stop command from the LCP, digital input, or serial communication. |
| Trip | An alarm occurred and the motor is stopped. Once the cause of the alarm is cleared, the frequency converter can be reset manually by pressing [Reset] or remotely by control terminals or serial communication. |
| Trip lock | An alarm occurred and the motor is stopped. Once the cause of the alarm is cleared, power must be cycled to the frequency converter. The frequency converter can then be reset manually by pressing [Reset], or remotely by control terminals or serial communication. |

Table 7.3 Operation Status

NOTICE

In auto/remote mode, the frequency converter requires external commands to execute functions.

7.3 Warning and Alarm Types

Warnings

A warning is issued when an alarm condition is impending or when an abnormal operating condition is present and may result in the frequency converter issuing an alarm. A warning clears by itself when the abnormal condition ceases.

Alarms

Trip

An alarm is issued when the frequency converter is tripped, meaning that the frequency converter suspends operation to prevent frequency converter or system damage. The motor coasts to a stop. The frequency converter logic continues to operate and monitor the frequency converter status. After the fault condition is remedied, the frequency converter can be reset. It is then ready to start operation again.

Resetting the frequency converter after trip/trip lock

A trip can be reset in any of 4 ways:

- Press [Reset] on the LCP.
- Digital reset input command.
- Serial communication reset input command.
- Auto reset.

Trip lock

Input power is cycled. The motor coasts to a stop. The frequency converter continues to monitor the frequency converter status. Remove input power to the frequency converter, correct the cause of the fault, and reset the frequency converter.

Warning and alarm displays

- A warning is displayed in the LCP along with the warning number.
- An alarm flashes along with the alarm number.

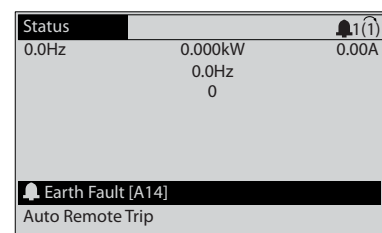
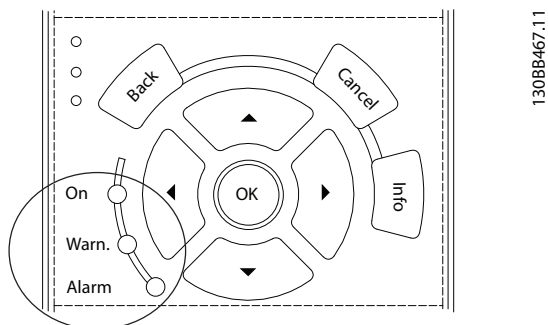

Illustration 7.2 Alarm Display Example

In addition to the text and alarm code in the LCP, there are 3 status indicator lights.



| | Warning indicator light | Alarm indicator light |
|-----------|-------------------------|-----------------------|
| Warning | On | Off |
| Alarm | Off | On (Flashing) |
| Trip-Lock | On | On (Flashing) |

Illustration 7.3 Status Indicator Lights

7.4 List of Warnings and Alarms

The warning/alarm information in this chapter defines each warning/alarm condition, provides the probable cause for the condition, and details a remedy or troubleshooting procedure.

WARNING 1, 10 Volts low

The control card voltage from terminal 50 is <10 V. Remove some of the load from terminal 50, as the 10 V supply is overloaded. Maximum 15 mA or minimum 590 Ω.

A short circuit in a connected potentiometer or improper wiring of the potentiometer can cause this condition.

Troubleshooting

- Remove the wiring from terminal 50.
- If the warning clears, the problem is with the customer wiring.
- If the warning does not clear, replace the control card.

WARNING/ALARM 2, Live zero error

This warning or alarm only appears if programmed in 6-01 Live Zero Timeout Function. The signal on one of the analog inputs is less than 50% of the minimum value programmed for that input. Broken wiring or signals being sent by a faulty device causes this condition.

Troubleshooting

- Check connections on all the analog input terminals. Control card terminals 53 and 54 for signals, terminal 55 common. MCB 101 terminals 11 and 12 for signals, terminal 10 common. MCB 109 terminals 1, 3, 5 for signals, terminals 2, 4, 6 common).
- Check that the frequency converter programming and switch settings match the analog signal type.

- Perform an input terminal signal test.

WARNING/ALARM 3, No motor

No motor has been connected to the output of the frequency converter.

WARNING/ALARM 4, Mains phase loss

A phase is missing on the supply side, or the mains voltage imbalance is too high. This message also appears in case of a fault in the input rectifier on the frequency converter. Options are programmed in 14-12 Function at Mains Imbalance.

Troubleshooting

- Check the supply voltage and supply currents to the frequency converter.

WARNING 5, DC link voltage high

The intermediate circuit voltage (DC) is higher than the high-voltage warning limit. The limit depends on the frequency converter voltage rating. The unit is still active.

WARNING 6, DC link voltage low

The intermediate circuit voltage (DC) is lower than the low-voltage warning limit. The limit depends on the frequency converter voltage rating. The unit is still active.

WARNING/ALARM 7, DC overvoltage

If the intermediate circuit voltage exceeds the limit, the frequency converter trips after some time.

Troubleshooting

- Connect a brake resistor.
- Extend the ramp time.
- Change the ramp type.
- Activate the functions in 2-10 Brake Function.
- Increase 14-26 Trip Delay at Inverter Fault.

WARNING/ALARM 8, DC under voltage

If the intermediate circuit voltage (DC link) drops below the undervoltage limit, the frequency converter checks if a 24 V DC back-up supply is connected. If no 24 V DC back-up supply is connected, the frequency converter trips after a fixed time delay. The time delay varies with unit size.

Troubleshooting

- Check that the supply voltage matches the frequency converter voltage.
- Perform an input voltage test.
- Perform a soft charge circuit test.

WARNING/ALARM 9, Inverter overload

The frequency converter is about to cut out because of an overload (too high current for too long). The counter for electronic thermal inverter protection issues a warning at 98% and trips at 100%, while issuing an alarm. The frequency converter *cannot* be reset until the counter is below 90%.

Troubleshooting

- Compare the output current shown on the LCP with the frequency converter rated current.
- Compare the output current shown on the LCP with measured motor current.
- Display the thermal drive load on the LCP and monitor the value. When running above the frequency converter continuous current rating, the counter should increase. When running below the frequency converter continuous current rating, the counter should decrease.

WARNING/ALARM 10, Motor overload temperature

According to the electronic thermal protection (ETR), the motor is too hot. Select whether the frequency converter issues a warning or an alarm when the counter reaches 100% in *1-90 Motor Thermal Protection*. The fault occurs when the motor overload exceeds 100% for too long.

Troubleshooting

- Check for motor overheating.
- Check if the motor is mechanically overloaded.
- Check that the motor current set in *1-24 Motor Current* is correct.
- Ensure the motor data in parameters *1-20* through *1-25* is set correctly.
- If an external fan is used, check that it is selected in *1-91 Motor External Fan*.
- Running AMA in *1-29 Automatic Motor Adaptation (AMA)* tunes the frequency converter to the motor more accurately and reduces thermal loading.

WARNING/ALARM 11, Motor thermistor overtemp

The thermistor might be disconnected. Select whether the frequency converter issues a warning or an alarm in *1-90 Motor Thermal Protection*.

Troubleshooting

- Check for motor overheating.
- Check if the motor is mechanically overloaded.
- Check that the thermistor is connected correctly between either terminal 53 or 54 (analog voltage input) and terminal 50 (+10 V supply) and that the terminal switch for 53 or 54 is set for voltage. Check *1-93 Thermistor Source* selects terminal 53 or 54.
- When using digital inputs 18 or 19, check that the thermistor is connected correctly between either terminal 18 or 19 (digital input PNP only) and terminal 50.
- If a KTY sensor is used, check for correct connection between terminals 54 and 55.

- If using a thermal switch or thermistor, check that the programming in *1-93 Thermistor Source* matches sensor wiring.
- If using a KTY sensor, check the programming of *1-95 KTY Sensor Type*, and *1-97 KTY Threshold level* match sensor wiring.

WARNING/ALARM 12, Torque limit

The torque has exceeded the value in *4-16 Torque Limit Motor Mode* or the value in *4-17 Torque Limit Generator Mode*. *14-25 Trip Delay at Torque Limit* can change this from a warning-only condition to a warning followed by an alarm.

Troubleshooting

- If the motor torque limit is exceeded during ramp-up, extend the ramp-up time.
- If the generator torque limit is exceeded during ramp down, extend the ramp-down time.
- If torque limit occurs while running, possibly increase the torque limit. Be sure that the system can operate safely at a higher torque.
- Check the application for excessive current draw on the motor.

WARNING/ALARM 13, Over current

The inverter peak current limit (approximately 200% of the rated current) is exceeded. The warning lasts about 1.5 s, then the frequency converter trips and issues an alarm. Shock loading or fast acceleration with high-inertia loads can cause this fault. If extended mechanical brake control is selected, the trip can be reset externally.

Troubleshooting

- Remove power and check if the motor shaft can be turned.
- Check that the motor size matches the frequency converter.
- Check parameters *1-20* to *1-25* for correct motor data.

ALARM 14, Earth (ground) fault

There is current from the output phases to ground, either in the cable between the frequency converter and the motor or in the motor itself.

Troubleshooting

- Remove power from the frequency converter and repair the ground fault.
- Check for ground faults in the motor by measuring the resistance to ground of the motor leads and the motor with a megohmmeter.
- Perform current sensor test.

ALARM 15, Hardware mismatch

A fitted option is not operational with the present control board hardware or software.

Record the value of the following parameters and contact the local Danfoss supplier:

- 15-40 FC Type.
- 15-41 Power Section.
- 15-42 Voltage.
- 15-43 Software Version.
- 15-45 Actual Typecode String.
- 15-49 SW ID Control Card.
- 15-50 SW ID Power Card.
- 15-60 Option Mounted.
- 15-61 Option SW Version (for each option slot).

ALARM 16, Short circuit

There is short-circuiting in the motor or motor wiring.

Troubleshooting

- Remove power from the frequency converter and repair the short circuit.

WARNING/ALARM 17, Control word timeout

There is no communication to the frequency converter. The warning is only active when 8-04 Control Timeout Function is NOT set to [0] Off.

If 8-04 Control Timeout Function is set to [5] Stop and trip, a warning appears and the frequency converter ramps down until it trips, then it displays an alarm.

Troubleshooting

- Check the connections on the serial communication cable.
- Increase 8-03 Control Timeout Time.
- Check the operation of the communication equipment.
- Verify a proper installation based on EMC requirements.

WARNING/ALARM 22, Hoist mechanical brake

When this warning is active, the LCP shows the type of issue.

0 = The torque ref. was not reached before timeout.

1 = There was no brake feedback before timeout.

WARNING 23, Internal fan fault

The fan warning function is an extra protective function that checks if the fan is running/mounted. The fan warning can be disabled in 14-53 Fan Monitor ([0] Disabled).

Troubleshooting

- Check the fan resistance.
- Check the soft charge fuses.

WARNING 24, External fan fault

The fan warning function is an extra protective function that checks if the fan is running/mounted. The fan warning can be disabled in 14-53 Fan Monitor ([0] Disabled).

Troubleshooting

- Check the fan resistance.
- Check the soft charge fuses.

WARNING 25, Brake resistor short circuit

The brake resistor is monitored during operation. If a short circuit occurs, the brake function is disabled and the warning appears. The frequency converter is still operational but without the brake function. Remove power from the frequency converter and replace the brake resistor (see 2-15 Brake Check).

WARNING/ALARM 26, Brake resistor power limit

The power transmitted to the brake resistor is calculated as a mean value over the last 120 s of run time. The calculation is based on the intermediate circuit voltage and the brake resistance value set in 2-16 AC brake Max. Current. The warning is active when the dissipated braking is higher than 90% of the brake resistance power. If [2] Trip is selected in 2-13 Brake Power Monitoring, the frequency converter trips when the dissipated braking power reaches 100%.

WARNING/ALARM 27, Brake chopper fault

The brake transistor is monitored during operation. If a short circuit occurs, the brake function is disabled and a warning is issued. The frequency converter is still operational, but since the brake transistor has short-circuited, substantial power is transmitted to the brake resistor, even if it is inactive.

Remove power from the frequency converter and remove the brake resistor.

This alarm/warning could also occur if the brake resistor overheats. Terminals 104 and 106 are available as brake resistor Klaxon inputs, see Brake Resistor Temperature Switch in the design guide.

WARNING/ALARM 28, Brake check failed

The brake resistor is not connected or not working. Check 2-15 Brake Check.

ALARM 29, Heat Sink temp

The maximum temperature of the heatsink has been exceeded. The temperature fault does not reset until the temperature drops below a defined heatsink temperature. The trip and reset points vary based on the frequency converter power size.

Troubleshooting

Check for the following conditions:

- Ambient temperature too high.
- Motor cable too long.
- Incorrect airflow clearance above and below the frequency converter.
- Blocked airflow around the frequency converter.
- Damaged heatsink fan.
- Dirty heatsink.

This alarm is based on the temperature measured by the heatsink sensor mounted inside the IGBT modules.

Troubleshooting

- Check the fan resistance.
- Check the soft charge fuses.
- Check the IGBT thermal sensor.

ALARM 30, Motor phase U missing

Motor phase U between the frequency converter and the motor is missing.

Troubleshooting

- Remove power from the frequency converter and check motor phase U.

ALARM 31, Motor phase V missing

Motor phase V between the frequency converter and the motor is missing.

Troubleshooting

- Remove power from the frequency converter and check motor phase V.

ALARM 32, Motor phase W missing

Motor phase W between the frequency converter and the motor is missing.

Troubleshooting

- Remove power from the frequency converter and check motor phase W.

ALARM 33, Inrush fault

Too many power-ups have occurred within a short time period. Let the unit cool to operating temperature.

WARNING/ALARM 34, Fieldbus communication fault

The fieldbus on the communication option card is not working.

WARNING/ALARM 36, Mains failure

This warning/alarm is only active if the supply voltage to the frequency converter is lost and *14-10 Mains Failure* is NOT set to [0] *No Function*.

Troubleshooting

- Check the fuses to the frequency converter and mains power supply to the unit.

ALARM 38, Internal fault

When an internal fault occurs, a code number defined in *Table 7.4* is displayed.

Troubleshooting

- Cycle power.
- Check that the option is properly installed.
- Check for loose or missing wiring.

Contact the Danfoss supplier or Danfoss service if necessary. Note the code number for further troubleshooting directions.

| No. | Text |
|---------|---|
| 0 | Serial port cannot be initialised. Contact the Danfoss supplier or Danfoss Service. |
| 256–258 | Power EEPROM data is defective or too old. |
| 512 | Control board EEPROM data is defective or too old. |

| No. | Text |
|-----------|--|
| 513 | Communication timeout reading EEPROM data. |
| 514 | Communication timeout reading EEPROM data. |
| 515 | Application-oriented control cannot recognise the EEPROM data. |
| 516 | Cannot write to the EEPROM because a write command is in progress. |
| 517 | Write command is under timeout. |
| 518 | Failure in the EEPROM. |
| 519 | Missing or invalid barcode data in EEPROM. |
| 783 | Parameter value outside of min/max limits. |
| 1024–1279 | Sending a CAN telegram failed. |
| 1281 | Digital signal processor flash timeout. |
| 1282 | Power micro software version mismatch. |
| 1283 | Power EEPROM data version mismatch. |
| 1284 | Cannot read digital signal processor software version. |
| 1299 | Option SW in slot A is too old. |
| 1300 | Option SW in slot B is too old. |
| 1301 | Option SW in slot C0 is too old. |
| 1302 | Option SW in slot C1 is too old. |
| 1315 | Option SW in slot A is not supported (not allowed). |
| 1316 | Option SW in slot B is not supported (not allowed). |
| 1317 | Option SW in slot C0 is not supported (not allowed). |
| 1318 | Option SW in slot C1 is not supported (not allowed). |
| 1379 | Option A did not respond when calculating platform version. |
| 1380 | Option B did not respond when calculating platform version. |
| 1381 | Option C0 did not respond when calculating platform version. |
| 1382 | Option C1 did not respond when calculating platform version. |
| 1536 | An exception in the application-oriented control is registered. Debug information written in LCP. |
| 1792 | DSP watchdog is active. Debugging of power part data, motor-oriented control data not transferred correctly. |
| 2049 | Power data restarted. |
| 2064–2072 | H081x: option in slot x has restarted. |
| 2080–2088 | H082x: option in slot x has issued a power-up wait. |
| 2096–2104 | H983x: option in slot x has issued a legal power-up wait. |
| 2304 | Could not read any data from power EEPROM. |
| 2305 | Missing SW version from power unit. |
| 2314 | Missing power unit data from power unit. |
| 2315 | Missing SW version from power unit. |
| 2316 | Missing lo_statepage from power unit. |
| 2324 | Power card configuration is determined to be incorrect at power-up. |
| 2325 | A power card has stopped communicating while main power is applied. |

| No. | Text |
|-----------|---|
| 2326 | Power card configuration is determined to be incorrect after the delay for power cards to register. |
| 2327 | Too many power card locations have been registered as present. |
| 2330 | Power size information between the power cards does not match. |
| 2561 | No communication from DSP to ATACD. |
| 2562 | No communication from ATACD to DSP (state running). |
| 2816 | Stack overflow control board module. |
| 2817 | Scheduler slow tasks. |
| 2818 | Fast tasks. |
| 2819 | Parameter thread. |
| 2820 | LCP stack overflow. |
| 2821 | Serial port overflow. |
| 2822 | USB port overflow. |
| 2836 | cflistMempool too small. |
| 3072-5122 | Parameter value is outside its limits. |
| 5123 | Option in slot A: Hardware incompatible with control board hardware. |
| 5124 | Option in slot B: Hardware incompatible with Control board hardware. |
| 5125 | Option in slot C0: Hardware incompatible with control board hardware. |
| 5126 | Option in slot C1: Hardware incompatible with control board hardware. |
| 5376-6231 | Out of memory. |

Table 7.4 Code Numbers for Internal Faults

ALARM 39, Heat sink sensor

No feedback from the heat sink temperature sensor.

The signal from the IGBT thermal sensor is not available on the power card. The problem could be on the power card, on the gate drive card, or the ribbon cable between the power card and gate drive card.

WARNING 40, Overload of digital output terminal 27

Check the load connected to terminal 27 or remove the short-circuit connection. Check *5-00 Digital I/O Mode* and *5-01 Terminal 27 Mode*.

WARNING 41, Overload of digital output terminal 29

Check the load connected to terminal 29 or remove the short-circuit connection. Check *5-00 Digital I/O Mode* and *5-02 Terminal 29 Mode*.

WARNING 42, Overload of digital output on X30/6 or overload of digital output on X30/7

For X30/6, check the load connected to X30/6 or remove the short-circuit connection. Check *5-32 Term X30/6 Digi Out (MCB 101)*.

For X30/7, check the load connected to X30/7 or remove the short-circuit connection. Check *5-33 Term X30/7 Digi Out (MCB 101)*.

ALARM 46, Power card supply

The supply on the power card is out of range.

There are 3 power supplies generated by the switch mode power supply (SMPS) on the power card: 24 V, 5 V, ± 18 V. When powered with 24 V DC with the MCB 107 option, only the 24 V and 5 V supplies are monitored. When powered with 3-phase mains voltage, all 3 supplies are monitored.

WARNING 47, 24 V supply low

The 24 V DC supply is measured on the control card. The external 24 V DC back-up power supply may be overloaded, otherwise contact the Danfoss supplier.

WARNING 48, 1.8 V supply low

The 1.8 V DC supply used on the control card is outside of the allowable limits. The power supply is measured on the control card. Check for a defective control card. If an option card is present, check for an overvoltage condition.

WARNING 49, Speed limit

When the speed is not within the specified range in *4-11 Motor Speed Low Limit [RPM]* and *4-13 Motor Speed High Limit [RPM]*, the frequency converter displays a warning. When the speed is below the specified limit in *1-86 Trip Speed Low [RPM]* (except when starting or stopping) the frequency converter trips.

ALARM 50, AMA calibration failed

Contact the Danfoss supplier or Danfoss Service.

ALARM 51, AMA check U_{nom} and I_{nom}

The settings for motor voltage, motor current, and motor power are wrong. Check the settings in parameters *1-20* to *1-25*.

ALARM 52, AMA low I_{nom}

The motor current is too low. Check the settings.

ALARM 53, AMA motor too big

The motor is too big for the AMA to operate.

ALARM 54, AMA motor too small

The motor is too small for the AMA to operate.

ALARM 55, AMA parameter out of range

The parameter values of the motor are outside of the acceptable range. AMA does not run.

ALARM 56, AMA interrupted by user

The user has interrupted the AMA.

ALARM 57, AMA internal fault

Try to restart AMA a number of times, until the AMA is carried out. Note that repeated runs may heat the motor to a level where the resistance R_s and R_r are increased. In most cases, however, this is not critical.

ALARM 58, AMA Internal fault

Contact the Danfoss supplier.

WARNING 59, Current limit

The current is higher than the value in *4-18 Current Limit*. Ensure that motor data in parameters *1-20* to *1-25* are set correctly. Possibly increase the current limit. Be sure that the system can operate safely at a higher limit.

WARNING 60, External interlock

External interlock has been activated. To resume normal operation:

1. Apply 24 V DC to the terminal programmed for external interlock.
2. Reset the frequency converter via
 - 2a serial communication.
 - 2b digital I/O.
 - 2c by pressing [Reset].

WARNING 62, Output frequency at maximum limit

The output frequency is higher than the value set in *4-19 Max Output Frequency*.

WARNING 64, Voltage Limit

The load and speed combination demands a motor voltage higher than the actual DC link voltage.

WARNING/ALARM 65, Control card over temperature

The control card has reached its trip temperature of 75 °C.

WARNING 66, Heat sink temperature low

The frequency converter is too cold to operate. This warning is based on the temperature sensor in the IGBT module.

Increase the ambient temperature of the unit. Also, a trickle amount of current can be supplied to the frequency converter whenever the motor is stopped by setting *2-00 DC Hold/Preheat Current* at 5% and *1-80 Function at Stop*.

Troubleshooting

- Check the temperature sensor.
- Check the sensor wire between the IGBT and the gate drive card.

ALARM 67, Option module configuration has changed

One or more options have either been added or removed since the last power-down. Check that the configuration change is intentional and reset the unit.

ALARM 68, Safe Stop activated

STO has been activated.

Troubleshooting

- To resume normal operation, apply 24 V DC to terminal 37, then send a reset signal (via bus, digital I/O, or by pressing [Reset]).

ALARM 69, Power card temperature

The temperature sensor on the power card is either too hot or too cold.

Troubleshooting

- Check the operation of the door fans.
- Check that the filters for the door fans are not blocked.
- Check that the gland plate is properly installed on IP21/IP54 (NEMA 1/12) frequency converters.

ALARM 70, Illegal FC configuration

The control card and power card are incompatible.

Troubleshooting

- Contact the supplier with the type code of the unit from the nameplate and the part numbers of the cards to check compatibility.

ALARM 71, PTC 1 safe stop

Safe Stop has been activated from the VLT® PTC Thermistor Card MCB 112 (motor too warm). Normal operation can be resumed when the MCB 112 applies 24 V DC to T37 again (when the motor temperature reaches an acceptable level) and when the digital input from the MCB 112 is deactivated. When that happens, a reset signal must be sent (via bus, digital I/O, or by pressing [Reset]).

NOTICE

If automatic restart is enabled, the motor may start when the fault is cleared.

ALARM 72, Dangerous failure

Safe Torque Off (STO) with trip lock. Unexpected signal levels on safe torque off (STO) and digital input from the VLT® PTC Thermistor Card MCB 112.

WARNING 73, Safe Stop auto restart

Safe Torque Off (STO). With automatic restart enabled, the motor can start when the fault is cleared.

WARNING 76, Power unit setup

The required number of power units does not match the detected number of active power units. When replacing an enclosure size F module, this warning occurs if the power-specific data in the module power card does not match the rest of the frequency converter. The warning is also triggered if the power card connection is lost.

Troubleshooting

- Confirm that the spare part and its power card are the correct part number.
- Ensure that the 44-pin cables between the MDCIC and power cards are mounted properly.

WARNING 77, Reduced power mode

This warning indicates that the frequency converter is operating in reduced power mode (that is, less than the allowed number of inverter sections). This warning is generated on power cycle when the frequency converter is set to run with fewer inverters and remains on.

ALARM 79, Illegal power section configuration

The scaling card is the incorrect part number or not installed. Also, the MK102 connector on the power card could not be installed.

ALARM 80, Drive initialised to default value

Parameter settings are initialised to default settings after a manual reset.

Troubleshooting

- Reset the unit to clear the alarm.

ALARM 81, CSIV corrupt

CSIV (Customer Specific Initialisation Values) file has syntax errors.

ALARM 82, CSIV parameter error

CSIV (Customer Specific Initialisation Values) failed to initialise a parameter.

ALARM 85, Dang fail PB

PROFIBUS/PROFIsafe error.

ALARM 92, No flow

A no-flow condition has been detected in the system. *22-23 No-Flow Function* is set for alarm.

Troubleshooting

- Troubleshoot the system and reset the frequency converter after the fault has been cleared.

ALARM 93, Dry pump

A no-flow condition in the system with the frequency converter operating at high speed may indicate a dry pump. *22-26 Dry Pump Function* is set for alarm.

Troubleshooting

- Troubleshoot the system and reset the frequency converter after the fault has been cleared.

ALARM 94, End of curve

The feedback is lower than the setpoint. This may indicate leakage in the system. *22-50 End of Curve Function* is set for alarm.

Troubleshooting

- Troubleshoot the system and reset the frequency converter after the fault has been cleared.

ALARM 95, Broken belt

Torque is below the torque level set for no load, indicating a broken belt. *22-60 Broken Belt Function* is set for alarm.

Troubleshooting

- Troubleshoot the system and reset the frequency converter after the fault has been cleared.

ALARM 100, Derag limit fault

The *Deragging* feature failed during execution. Check the pump impeller for blockage.

WARNING/ALARM 104, Mixing fan fault

The fan monitor checks that the fan is spinning at frequency converter power-up or whenever the mixing fan is turned on. If the fan is not operating, the fault is issued. The mixing-fan fault can be configured as a warning or an alarm trip by *14-53 Fan Monitor*.

Troubleshooting

- Cycle power to the frequency converter to determine if the warning/alarm returns.

WARNING 250, New spare part

A component in the frequency converter has been replaced. To resume normal operation, reset the frequency converter.

WARNING 251, New typecode

The power card or other components have been replaced and the type code changed.

Troubleshooting

- Reset to remove the warning and resume normal operation.

7.5 Troubleshooting

| Symptom | Possible cause | Test | Solution |
|----------------------------------|--|---|--|
| Display dark/No function | Missing input power. | See <i>Table 4.3</i> . | Check the input power source. |
| | Missing or open fuses or circuit breaker tripped. | See open fuses and tripped circuit breaker in this table for possible causes. | Follow the recommendations provided. |
| | No power to the LCP. | Check the LCP cable for proper connection or damage. | Replace the faulty LCP or connection cable. |
| | Shortcut on control voltage (terminal 12 or 50) or at control terminals. | Check the 24 V control voltage supply for terminals 12/13 to 20-39 or 10 V supply for terminals 50-55. | Wire the terminals properly. |
| | Incompatible LCP (LCP from VLT® 2800 or 5000/6000/8000/FCD or FCM). | | Use only LCP 101 (P/N 130B1124) or LCP 102 (P/N 130B1107). |
| | Wrong contrast setting. | | Press [Status] + [▲]/[▼] to adjust the contrast. |
| | Display (LCP) is defective. | Test using a different LCP. | Replace the faulty LCP or connection cable. |
| | Internal voltage supply fault or SMPS is defective. | | Contact supplier. |
| Intermittent display | Overloaded power supply (SMPS) due to improper control wiring or a fault within the frequency converter. | To rule out a problem in the control wiring, disconnect all control wiring by removing the terminal blocks. | If the display stays lit, the problem is in the control wiring. Check the wiring for short circuits or incorrect connections. If the display continues to cut out, follow the procedure for display dark. |
| Motor not running | Service switch is open or missing motor connection. | Check if the motor is connected and the connection is not interrupted (by a service switch or other device). | Connect the motor and check the service switch. |
| | No mains power with 24 V DC option card. | If the display is functioning but no output, check that mains power is applied to the frequency converter. | Apply mains power to run the unit. |
| | LCP stop. | Check if [Off] has been pressed. | Press [Auto On] or [Hand On] (depending on operation mode) to run the motor. |
| | Missing start signal (Standby). | Check <i>5-10 Terminal 18 Digital Input</i> for correct setting for terminal 18 (use default setting). | Apply a valid start signal to start the motor. |
| | Motor coast signal active (Coasting). | Check <i>5-12 Terminal 27 Digital Input</i> for correct setting for terminal 27 (use default setting). | Apply 24 V on terminal 27 or program this terminal to <i>No operation</i> . |
| | Wrong reference signal source. | Check reference signal: Local, remote or bus reference? Preset reference active? Terminal connection correct? Scaling of terminals correct? Reference signal available? | Programme the correct settings. Check <i>3-13 Reference Site</i> . Set preset reference active in parameter group <i>3-1* References</i> . Check for correct wiring. Check scaling of terminals. Check reference signal. |
| Motor running in wrong direction | Motor rotation limit. | Check that <i>4-10 Motor Speed Direction</i> is programmed correctly. | Programme the correct settings. |
| | Active reversing signal. | Check if a reversing command is programmed for the terminal in parameter group <i>5-1* Digital inputs</i> . | Deactivate reversing signal. |
| | Wrong motor phase connection. | | See <i>chapter 5.5 Checking Motor Rotation</i> . |

| Symptom | Possible cause | Test | Solution |
|---|--|--|--|
| Motor is not reaching maximum speed | Frequency limits are set incorrectly. | Check the output limits in 4-13 <i>Motor Speed High Limit [RPM]</i> , 4-14 <i>Motor Speed High Limit [Hz]</i> and 4-19 <i>Max Output Frequency</i> . | Programme the correct limits. |
| | Reference input signal is not scaled correctly. | Check the reference input signal scaling in parameter group 6-0* <i>Analog I/O Mode</i> and parameter group 3-1* <i>References</i> . Check the reference limits in parameter group 3-0* <i>Reference Limit</i> . | Programme the correct settings. |
| Motor speed unstable | Possible incorrect parameter settings. | Check the settings of all motor parameters, including all motor compensation settings. For closed-loop operation, check the PID settings. | Check the settings in parameter group 1-6* <i>Load Depen. Setting</i> . For closed-loop operation, check the settings in parameter group 20-0* <i>Feedback</i> . |
| Motor runs rough | Possible over-magnetisation. | Check for incorrect motor settings in all motor parameters. | Check the motor settings in parameter groups 1-2* <i>Motor Data</i> , 1-3* <i>Adv Motor Data</i> , and 1-5* <i>Load Indep. Setting</i> . |
| Motor will not brake | Possible incorrect settings in the brake parameters. Possible too short ramp-down times. | Check the brake parameters. Check the ramp-time settings. | Check parameter group 2-0* <i>DC Brake</i> and 3-0* <i>Reference Limits</i> . |
| Open power fuses or circuit breaker trip | Phase-to-phase short circuit. | The motor or panel has a short phase-to-phase. Check the motor and panel phase for short circuits. | Eliminate any short circuits detected. |
| | Motor overload. | Motor is overloaded for the application. | Perform a startup test and verify the motor current is within the specifications. If the motor current exceeds the nameplate full load current, the motor may run only with reduced load. Review the specifications for the application. |
| | Loose connections. | Perform a pre-startup check for loose connections. | Tighten any loose connections. |
| Mains current imbalance >3% | Problem with the mains power (See <i>Alarm 4 Mains phase loss</i> description). | Rotate input power leads into the frequency converter 1 position: A to B, B to C, C to A. | If imbalanced leg follows the wire, it is a power problem. Check the mains power supply. |
| | Problem with the frequency converter. | Rotate input power leads into the frequency converter 1 position: A to B, B to C, C to A. | If imbalance leg stays on the same input terminal, it is a problem with the unit. Contact the supplier. |
| Motor current imbalance >3% | Problem with the motor or motor wiring. | Rotate output motor leads 1 position: U to V, V to W, W to U. | If imbalanced leg follows the wire, the problem is in the motor or motor wiring. Check the motor and motor wiring. |
| | Problem with the frequency converter. | Rotate output motor leads 1 position: U to V, V to W, W to U. | If imbalance leg stays on same output terminal, it is a problem with the frequency converter. Contact the Danfoss supplier. |
| Frequency converter acceleration problems | Motor data was entered incorrectly. | If warnings or alarms occur, see <i>chapter 7.4 List of Warnings and Alarms</i> . Check that motor data is entered correctly. | Increase the ramp-up time in 3-41 <i>Ramp 1 Ramp Up Time</i> . Increase the current limit in 4-18 <i>Current Limit</i> . Increase the torque limit in 4-16 <i>Torque Limit Motor Mode</i> . |
| Frequency converter deceleration problems | Motor data was entered incorrectly. | If warnings or alarms occur, see <i>chapter 7.4 List of Warnings and Alarms</i> . Check that motor data is entered correctly. | Increase the ramp-down time in 3-42 <i>Ramp 1 Ramp Down Time</i> . Enable overvoltage control in 2-17 <i>Over-voltage Control</i> . |

| Symptom | Possible cause | Test | Solution |
|-----------------------------|----------------|---|---|
| Acoustic noise or vibration | Resonances. | Bypass critical frequencies by using parameters in parameter group 4-6* <i>Speed Bypass</i> . | Check if noise and/or vibration have been reduced to an acceptable limit. |
| | | Turn off over-modulation in 14-03 <i>Overmodulation</i> . | |
| | | Change the switching pattern and frequency in parameter group 14-0* <i>Inverter Switching</i> . | |
| | | Increase Resonance Dampening in 1-64 <i>Resonance Damping</i> . | |

Table 7.5 Troubleshooting

8 Specifications

8.1 Electrical Data

8.1.1 Mains Supply 1x200–240 V AC

| Type designation | P1K1 | P1K5 | P2K2 | P3K0 | P3K7 | P5K5 | P7K5 | P15K | P22K |
|--|--------------|--------|--------|--------|--------|--------|--------|----------|------------------------------------|
| Typical shaft output [kW] | 1.1 | 1.5 | 2.2 | 3.0 | 3.7 | 5.5 | 7.5 | 15 | 22 |
| Typical shaft output at 240 V [hp] | 1.5 | 2.0 | 2.9 | 4.0 | 4.9 | 7.5 | 10 | 20 | 30 |
| Protection rating IP20/Chassis | A3 | – | – | – | – | – | – | – | – |
| Protection rating IP21/Type 1 | – | B1 | B1 | B1 | B1 | B1 | B2 | C1 | C2 |
| Protection rating IP55/Type 12 | A5 | B1 | B1 | B1 | B1 | B1 | B2 | C1 | C2 |
| Protection rating IP66/NEMA 4X | A5 | B1 | B1 | B1 | B1 | B1 | B2 | C1 | C2 |
| Output current | | | | | | | | | |
| Continuous (3x200–240 V) [A] | 6.6 | 7.5 | 10.6 | 12.5 | 16.7 | 24.2 | 30.8 | 59.4 | 88 |
| Intermittent (3x200–240 V) [A] | 7.3 | 8.3 | 11.7 | 13.8 | 18.4 | 26.6 | 33.4 | 65.3 | 96.8 |
| Continuous kVA at 208 V [kVA] | 2.4 | 2.7 | 3.8 | 4.5 | 6.0 | 8.7 | 11.1 | 21.4 | 31.7 |
| Maximum input current | | | | | | | | | |
| Continuous (1x200–240 V) [A] | 12.5 | 15 | 20.5 | 24 | 32 | 46 | 59 | 111 | 172 |
| Intermittent (1x200–240 V) [A] | 13.8 | 16.5 | 22.6 | 26.4 | 35.2 | 50.6 | 64.9 | 122.1 | 189.2 |
| Maximum pre-fuses [A] | 20 | 30 | 40 | 40 | 60 | 80 | 100 | 150 | 200 |
| Additional specifications | | | | | | | | | |
| Maximum cable cross-section (mains, motor, brake) [mm ²] ([AWG]) | 0.2–4 (4–10) | | | | | 10 (7) | 35 (2) | 50 (1/0) | 95 (4/0) |
| Maximum cable cross-section for mains with disconnect switch [mm ²] ([AWG]) | 5.26 (10) | 16 (6) | 16 (6) | 16 (6) | 16 (6) | 16 (6) | 25 (3) | 50 (1/0) | 2 x 50 (2 x 1/0) ^{9) 10)} |
| Maximum cable cross-section for mains without disconnect switch [mm ²] ([AWG]) | 5.26 (10) | 16 (6) | 16 (6) | 16 (6) | 16 (6) | 16 (6) | 25 (3) | 50 (1/0) | 95 (4/0) |
| Cable insulation temperature rating [°C] | 75 | 75 | 75 | 75 | 75 | 75 | 75 | 75 | 75 |
| Estimated power loss ³⁾ at rated maximum load [W] ⁴⁾ | 44 | 30 | 44 | 60 | 74 | 110 | 150 | 300 | 440 |
| Efficiency ⁵⁾ | 0.98 | 0.98 | 0.98 | 0.98 | 0.98 | 0.98 | 0.98 | 0.98 | 0.98 |

Table 8.1 Mains Supply 1x200–240 V AC, Normal Overload 110% for 1 Minute, P1K1–P22K

8.1.2 Mains Supply 3x200–240 V AC

| Type designation | PK25 | | PK37 | | PK55 | | PK75 | |
|--|--|-----|-------|-----|-------|-----|-------|-----|
| | HO | NO | HO | NO | HO | NO | HO | NO |
| High/normal overload ¹⁾ | | | | | | | | |
| Typical shaft output [kW] | 0.25 | | 0.37 | | 0.55 | | 0.75 | |
| Typical shaft output at 208 V [hp] | 0.34 | | 0.5 | | 0.75 | | 1 | |
| Protection rating IP20/Chassis ⁶⁾ | A2 | | A2 | | A2 | | A2 | |
| Protection rating IP21/Type 1 | A2 | | A2 | | A2 | | A2 | |
| Protection rating IP55/Type 12 | A4/A5 | | A4/A5 | | A4/A5 | | A4/A5 | |
| Protection rating IP66/NEMA 4X | A4/A5 | | A4/A5 | | A4/A5 | | A4/A5 | |
| Output current | | | | | | | | |
| Continuous (3x200–240 V) [A] | 1.8 | | 2.4 | | 3.5 | | 4.6 | |
| Intermittent (3x200–240 V) [A] | 2.7 | 2.0 | 3.6 | 2.6 | 5.3 | 3.9 | 6.9 | 5.1 |
| Continuous kVA at 208 V [kVA] | 0.65 | | 0.86 | | 1.26 | | 1.66 | |
| Maximum input current | | | | | | | | |
| Continuous (3x200–240 V) [A] | 1.6 | | 2.2 | | 3.2 | | 4.1 | |
| Intermittent (3x200–240 V) [A] | 2.4 | 1.8 | 3.3 | 2.4 | 4.8 | 3.5 | 6.2 | 4.5 |
| Maximum pre-fuses [A] | 10 | | 10 | | 10 | | 10 | |
| Additional specifications | | | | | | | | |
| Maximum cable cross-section ²⁾ for mains, motor, brake, and load sharing [mm ²] (AWG) | 4, 4, 4 (12, 12, 12) (minimum 0.2 (24)) | | | | | | | |
| Maximum cable cross-section ²⁾ for mains disconnect [mm ²] (AWG) | 6, 4, 4 (10, 12, 12) | | | | | | | |
| Estimated power loss ³⁾ at rated maximum load [W] ⁴⁾ | 21 | | 29 | | 42 | | 54 | |
| Efficiency ⁵⁾ | 0.94 | | 0.94 | | 0.95 | | 0.95 | |

8

Table 8.2 Mains Supply 3x200–240 V AC, PK25–PK75

| Type designation | P1K1 | | P1K5 | | P2K2 | | P3K0 | | P3K7 | |
|--|--|-----|-------|-----|-------|------|------|------|------|------|
| | HO | NO | HO | NO | HO | NO | HO | NO | HO | NO |
| High/normal overload ¹⁾ | | | | | | | | | | |
| Typical shaft output [kW] | 1.1 | | 1.5 | | 2.2 | | 3.0 | | 3.7 | |
| Typical shaft output at 208 V [hp] | 1.5 | | 2 | | 3 | | 4 | | 5 | |
| Protection rating IP20/Chassis ⁶⁾ | A2 | | A2 | | A2 | | A3 | | A3 | |
| Protection rating IP21/Type 1 | A2 | | A2 | | A2 | | A3 | | A3 | |
| Protection rating IP55/Type 12 | A4/A5 | | A4/A5 | | A4/A5 | | A5 | | A5 | |
| Protection rating IP66/NEMA 4X | A4/A5 | | A4/A5 | | A4/A5 | | A5 | | A5 | |
| Output current | | | | | | | | | | |
| Continuous (3x200–240 V) [A] | 6.6 | | 7.5 | | 10.6 | | 12.5 | | 16.7 | |
| Intermittent (3x200–240 V) [A] | 9.9 | 7.3 | 11.3 | 8.3 | 15.9 | 11.7 | 18.8 | 13.8 | 25 | 18.4 |
| Continuous kVA at 208 V [kVA] | 2.38 | | 2.70 | | 3.82 | | 4.50 | | 6.00 | |
| Maximum input current | | | | | | | | | | |
| Continuous (3x200–240 V) [A] | 5.9 | | 6.8 | | 9.5 | | 11.3 | | 15.0 | |
| Intermittent (3x200–240 V) [A] | 8.9 | 6.5 | 10.2 | 7.5 | 14.3 | 10.5 | 17.0 | 12.4 | 22.5 | 16.5 |
| Maximum pre-fuses [A] | 20 | | 20 | | 20 | | 32 | | 32 | |
| Additional specifications | | | | | | | | | | |
| Maximum cable cross-section ²⁾ for mains, motor, brake, and load sharing [mm ²] (AWG) | 4, 4, 4 (12, 12, 12) (minimum 0.2 (24)) | | | | | | | | | |
| Maximum cable cross-section ²⁾ for mains disconnect [mm ²] (AWG) | 6, 4, 4 (10, 12, 12) | | | | | | | | | |
| Estimated power loss ³⁾ at rated maximum load [W] ⁴⁾ | 63 | | 82 | | 116 | | 155 | | 185 | |
| Efficiency ⁵⁾ | 0.96 | | 0.96 | | 0.96 | | 0.96 | | 0.96 | |

Table 8.3 Mains Supply 3x200–240 V AC, P1K1–P3K7

| Type designation | P5K5 | | P7K5 | | P11K | | P15K | |
|--|----------------------|------|----------------------|------|----------------------|------|----------------------|------|
| High/normal overload ¹⁾ | HO | NO | HO | NO | HO | NO | HO | NO |
| Typical shaft output [kW] | 3.7 | 5.5 | 5.5 | 7.5 | 7.5 | 11 | 11 | 15 |
| Typical shaft output at 208 V [hp] | 5.0 | 7.5 | 7.5 | 10 | 10 | 15 | 15 | 20 |
| IP20/Chassis ⁷⁾ | B3 | | B3 | | B3 | | B4 | |
| Protection rating IP21/Type 1 | B1 | | B1 | | B1 | | B2 | |
| Protection rating IP55/Type 12 | | | | | | | | |
| Protection rating IP66/NEMA 4X | | | | | | | | |
| Output current | | | | | | | | |
| Continuous (3x200–240 V) [A] | 16.7 | 24.2 | 24.2 | 30.8 | 30.8 | 46.2 | 46.2 | 59.4 |
| Intermittent (3x200–240 V) [A] | 26.7 | 26.6 | 38.7 | 33.9 | 49.3 | 50.8 | 73.9 | 65.3 |
| Continuous kVA at 208 V [kVA] | 6.0 | 8.7 | 8.7 | 11.1 | 11.1 | 16.6 | 16.6 | 21.4 |
| Maximum input current | | | | | | | | |
| Continuous (3x200–240 V) [A] | 15.0 | 22.0 | 22.0 | 28.0 | 28.0 | 42.0 | 42.0 | 54.0 |
| Intermittent (3x200–240 V) [A] | 24.0 | 24.2 | 35.2 | 30.8 | 44.8 | 46.2 | 67.2 | 59.4 |
| Maximum pre-fuses [A] | 63 | | 63 | | 63 | | 80 | |
| Additional specifications | | | | | | | | |
| IP20 maximum cable cross-section ²⁾ for mains, brake, motor, and load sharing [mm ²] ([AWG]) | 10, 10, – (8, 8, –) | | 10, 10, – (8, 8, –) | | 10, 10, – (8, 8, –) | | 35, –, – (2, –, –) | |
| Protection rating IP21 maximum cable cross-section ²⁾ for mains, brake, and load sharing [mm ²] ([AWG]) | 16, 10, 16 (6, 8, 6) | | 16, 10, 16 (6, 8, 6) | | 16, 10, 16 (6, 8, 6) | | 35, –, – (2, –, –) | |
| Protection rating IP21 maximum cable cross-section ²⁾ for motor [mm ²] ([AWG]) | 10, 10, – (8, 8, –) | | 10, 10, – (8, 8, –) | | 10, 10, – (8, 8, –) | | 35, 25, 25 (2, 4, 4) | |
| Maximum cable cross-section ²⁾ for mains disconnect [mm ²] ([AWG]) | 16, 10, 10 (6, 8, 8) | | | | | | 35 (2) | |
| Estimated power loss ³⁾ at rated maximum load [W] ⁴⁾ | 239 | 310 | 239 | 310 | 371 | 514 | 463 | 602 |
| Efficiency ⁵⁾ | 0.96 | | 0.96 | | 0.96 | | 0.96 | |

Table 8.4 Mains Supply 3x200–240 V AC, P5K5–P15K

| Type designation | P18K | | P22K | | P30K | | P37K | | P45K | |
|---|--------|------|-------------------------|------|--------|------|-------------------------------|------|--|-------|
| High/normal overload ¹⁾ | HO | NO | HO | NO | HO | NO | HO | NO | HO | NO |
| Typical shaft output [kW] | 15 | 18.5 | 18.5 | 22 | 22 | 30 | 30 | 37 | 37 | 45 |
| Typical shaft output at 208 V [hp] | 20 | 25 | 25 | 30 | 30 | 40 | 40 | 50 | 50 | 60 |
| Protection rating IP20/Chassis ⁷⁾ | B4 | | C3 | | C3 | | C4 | | C4 | |
| Protection rating IP21/Type 1 | C1 | | C1 | | C1 | | C2 | | C2 | |
| Protection rating IP55/Type 12 | C1 | | C1 | | C1 | | C2 | | C2 | |
| Protection rating IP66/NEMA 4X | C1 | | C1 | | C1 | | C2 | | C2 | |
| Output current | | | | | | | | | | |
| Continuous (3x200–240 V) [A] | 59.4 | 74.8 | 74.8 | 88.0 | 88.0 | 115 | 115 | 143 | 143 | 170 |
| Intermittent (3x200–240 V) [A] | 89.1 | 82.3 | 112 | 96.8 | 132 | 127 | 173 | 157 | 215 | 187 |
| Continuous kVA at 208 V [kVA] | 21.4 | 26.9 | 26.9 | 31.7 | 31.7 | 41.4 | 41.4 | 51.5 | 51.5 | 61.2 |
| Maximum input current | | | | | | | | | | |
| Continuous (3x200–240 V) [A] | 54.0 | 68.0 | 68.0 | 80.0 | 80.0 | 104 | 104 | 130 | 130 | 154.0 |
| Intermittent (3x200–240 V) [A] | 81.0 | 74.8 | 102 | 88.0 | 120 | 114 | 156 | 143 | 195 | 169.0 |
| Maximum pre-fuses [A] | 125 | | 125 | | 160 | | 200 | | 250 | |
| Additional specifications | | | | | | | | | | |
| Protection rating IP20 maximum cable cross-section for mains, brake, motor, and load sharing [mm ²] ([AWG]) | 35 (2) | | 50 (1) | | 50 (1) | | 150 (300 MCM) | | 150 (300 MCM) | |
| Protection ratings IP21, IP55, IP66 maximum cable cross-section for mains and motor [mm ²] ([AWG]) | 50 (1) | | 50 (1) | | 50 (1) | | 150 (300 MCM) | | 150 (300 MCM) | |
| Protection ratings IP21, IP55, IP66 maximum cable cross-section for brake, and load sharing [mm ²] ([AWG]) | 50 (1) | | 50 (1) | | 50 (1) | | 95 (3/0) | | 95 (3/0) | |
| Maximum cable cross-section ²⁾ for disconnect [mm ²] ([AWG]) | | | 50, 35, 35 (1, 2, 2) | | | | 95, 70, 70 (3/0, 2/0, 2/0) | | 185, 150, 120 (350 MCM, 300 MCM, 4/0) | |
| Estimated power loss ³⁾ at rated maximum load [W] ⁴⁾ | 624 | 737 | 740 | 845 | 874 | 1140 | 1143 | 1353 | 1400 | 1636 |
| Efficiency ⁵⁾ | 0.96 | | 0.97 | | 0.97 | | 0.97 | | 0.97 | |

Table 8.5 Mains Supply 3x200–240 V AC, P18K–P45K

8.1.3 Mains Supply 1x380–480 V AC

| Type designation | P7K5 | P11K | P18K | P37K |
|------------------------------------|------|------|------|------|
| Typical shaft output [kW] | 7.5 | 11 | 18.5 | 37 |
| Typical shaft output at 240 V [hp] | 10 | 15 | 25 | 50 |
| Protection rating IP21/Type 1 | B1 | B2 | C1 | C2 |
| Protection rating IP55/Type 12 | B1 | B2 | C1 | C2 |
| Protection rating IP66/NEMA 4X | B1 | B2 | C1 | C2 |
| Output current | | | | |
| Continuous (3x380–440 V) [A] | 16 | 24 | 37.5 | 73 |
| Intermittent (3x380–440 V) [A] | 17.6 | 26.4 | 41.2 | 80.3 |
| Continuous (3x441–480 V) [A] | 14.5 | 21 | 34 | 65 |
| Intermittent (3x441–480 V) [A] | 15.4 | 23.1 | 37.4 | 71.5 |
| Continuous kVA at 400 V [kVA] | 11.0 | 16.6 | 26 | 50.6 |
| Continuous kVA at 460 V [kVA] | 11.6 | 16.7 | 27.1 | 51.8 |
| Maximum input current | | | | |
| Continuous (1x380–440 V) [A] | 33 | 48 | 78 | 151 |
| Intermittent (1x380–440 V) [A] | 36 | 53 | 85.5 | 166 |

| Type designation | P7K5 | P11K | P18K | P37K |
|--|--------|--------|----------|-----------|
| Continuous (1x441–480 V) [A] | 30 | 41 | 72 | 135 |
| Intermittent (1x441–480 V) [A] | 33 | 46 | 79.2 | 148 |
| Maximum pre-fuses [A] | 63 | 80 | 160 | 250 |
| Additional specifications | | | | |
| Maximum cable cross-section for mains, motor, and brake [mm ²] ([AWG]) | 10 (7) | 35 (2) | 50 (1/0) | 120 (4/0) |
| Estimated power loss ³⁾ at rated maximum load [W] ⁴⁾ | 300 | 440 | 740 | 1480 |
| Efficiency ⁵⁾ | 0.96 | 0.96 | 0.96 | 0.96 |

Table 8.6 Mains Supply 1x380–480 V AC, Normal Overload 110% for 1 Minute, P7K5–P37K

8.1.4 Mains Supply 3x380–480 V AC

| Type designation | PK37 | | PK55 | | PK75 | | P1K1 | | P1K5 | |
|---|--|-----|-------|-----|-------|-----|-------|-----|-------|-----|
| | HO | NO | HO | NO | HO | NO | HO | NO | HO | NO |
| High/normal overload ¹⁾ | | | | | | | | | | |
| Typical shaft output [kW] | 0.37 | | 0.55 | | 0.75 | | 1.1 | | 1.5 | |
| Typical shaft output at 460 V [hp] | 0.5 | | 0.75 | | 1.0 | | 1.5 | | 2.0 | |
| Protection rating IP20/Chassis ⁶⁾ | A2 | | A2 | | A2 | | A2 | | A2 | |
| Protection rating IP55/Type 12 | A4/A5 | | A4/A5 | | A4/A5 | | A4/A5 | | A4/A5 | |
| Protection rating IP66/NEMA 4X | A4/A5 | | A4/A5 | | A4/A5 | | A4/A5 | | A4/A5 | |
| Output current | | | | | | | | | | |
| Continuous (3x380–440 V) [A] | 1.3 | | 1.8 | | 2.4 | | 3.0 | | 4.1 | |
| Intermittent (3x380–440 V) [A] | 2.0 | 1.4 | 2.7 | 2.0 | 3.6 | 2.6 | 4.5 | 3.3 | 6.2 | 4.5 |
| Continuous (3x441–480 V) [A] | 1.2 | | 1.6 | | 2.1 | | 2.7 | | 3.4 | |
| Intermittent (3x441–480 V) [A] | 1.8 | 1.3 | 2.4 | 1.8 | 3.2 | 2.3 | 4.1 | 3.0 | 5.1 | 3.7 |
| Continuous kVA at 400 V [kVA] | 0.9 | | 1.3 | | 1.7 | | 2.1 | | 2.8 | |
| Continuous kVA at 460 V [kVA] | 0.9 | | 1.3 | | 1.7 | | 2.4 | | 2.7 | |
| Maximum input current | | | | | | | | | | |
| Continuous (3x380–440 V) [A] | 1.2 | | 1.6 | | 2.2 | | 2.7 | | 3.7 | |
| Intermittent (3x380–440 V) [A] | 1.8 | 1.3 | 2.4 | 1.8 | 3.3 | 2.4 | 4.1 | 3.0 | 5.6 | 4.1 |
| Continuous (3x441–480 V) [A] | 1.0 | | 1.4 | | 1.9 | | 2.7 | | 3.1 | |
| Intermittent (3x441–480 V) [A] | 1.5 | 1.1 | 2.1 | 1.5 | 2.9 | 2.1 | 4.1 | 3.0 | 4.7 | 3.4 |
| Maximum pre-fuses [A] | 10 | | 10 | | 10 | | 10 | | 10 | |
| Additional specifications | | | | | | | | | | |
| Protection ratings IP20, IP21 maximum cable cross-section ²⁾ for mains, motor, brake, and load sharing [mm ²] ([AWG]) | 4, 4, 4 (12, 12, 12) (minimum 0.2 (24)) | | | | | | | | | |
| Protection ratings IP55, IP66 maximum cable cross-section ²⁾ for mains, motor, brake, and load sharing [mm ²] ([AWG]) | 4, 4, 4 (12, 12, 12) | | | | | | | | | |
| Maximum cable cross-section ²⁾ for disconnect [mm ²] ([AWG]) | 6, 4, 4 (10, 12, 12) | | | | | | | | | |
| Estimated power loss ³⁾ at rated maximum load [W] ⁴⁾ | 35 | | 42 | | 46 | | 58 | | 62 | |
| Efficiency ⁵⁾ | 0.93 | | 0.95 | | 0.96 | | 0.96 | | 0.97 | |

Table 8.7 Mains Supply 3x380–480 V AC, PK37–P1K5

| Type designation | P2K2 | | P3K0 | | P4K0 | | P5K5 | | P7K5 | |
|---|--|-----|-------|-----|-------|------|------|------|------|------|
| | HO | NO | HO | NO | HO | NO | HO | NO | HO | NO |
| High/normal overload ¹⁾ | | | | | | | | | | |
| Typical shaft output [kW] | 2.2 | | 3.0 | | 4.0 | | 5.5 | | 7.5 | |
| Typical shaft output at 460 V [hp] | 2.9 | | 4.0 | | 5.3 | | 7.5 | | 10 | |
| Protection rating IP20/Chassis ⁶⁾ | A2 | | A2 | | A2 | | A3 | | A3 | |
| Protection rating IP55/Type 12 | A4/A5 | | A4/A5 | | A4/A5 | | A5 | | A5 | |
| Protection rating IP66/NEMA 4X | A4/A5 | | A4/A5 | | A4/A5 | | A5 | | A5 | |
| Output current | | | | | | | | | | |
| Continuous (3x380–440 V) [A] | 5.6 | | 7.2 | | 10 | | 13 | | 16 | |
| Intermittent (3x380–440 V) [A] | 8.4 | 6.2 | 10.8 | 7.9 | 15.0 | 11.0 | 19.5 | 14.3 | 24.0 | 17.6 |
| Continuous (3x441–480 V) [A] | 4.8 | | 6.3 | | 8.2 | | 11 | | 14.5 | |
| Intermittent (3x441–480 V) [A] | 7.2 | 5.3 | 9.5 | 6.9 | 12.3 | 9.0 | 16.5 | 12.1 | 21.8 | 16.0 |
| Continuous kVA at 400 V [kVA] | 3.9 | | 5.0 | | 6.9 | | 9.0 | | 11.0 | |
| Continuous kVA at 460 V [kVA] | 3.8 | | 5.0 | | 6.5 | | 8.8 | | 11.6 | |
| Maximum input current | | | | | | | | | | |
| Continuous (3x380–440 V) [A] | 5.0 | | 6.5 | | 9.0 | | 11.7 | | 14.4 | |
| Intermittent (3x380–440 V) [A] | 7.5 | 5.5 | 9.8 | 7.2 | 13.5 | 9.9 | 17.6 | 12.9 | 21.6 | 15.8 |
| Continuous (3x441–480 V) [A] | 4.3 | | 5.7 | | 7.4 | | 9.9 | | 13.0 | |
| Intermittent (3x441–480 V) [A] | 6.5 | 4.7 | 8.6 | 6.3 | 11.1 | 8.1 | 14.9 | 10.9 | 19.5 | 14.3 |
| Maximum pre-fuses [A] | 20 | | 20 | | 20 | | 30 | | 30 | |
| Additional specifications | | | | | | | | | | |
| Protection ratings IP20, IP21 maximum cable cross-section ²⁾ for mains, motor, brake, and load sharing [mm ²] ([AWG]) | 4, 4, 4 (12, 12, 12) (minimum 0.2 (24)) | | | | | | | | | |
| Protection ratings IP55, IP66 maximum cable cross-section ²⁾ for mains, motor, brake, and load sharing [mm ²] ([AWG]) | 4, 4, 4 (12, 12, 12) | | | | | | | | | |
| Maximum cable cross-section ²⁾ for disconnect [mm ²] ([AWG]) | 6, 4, 4 (10, 12, 12) | | | | | | | | | |
| Estimated power loss ³⁾ at rated maximum load [W] ⁴⁾ | 88 | | 116 | | 124 | | 187 | | 225 | |
| Efficiency ⁵⁾ | 0.97 | | 0.97 | | 0.97 | | 0.97 | | 0.97 | |

Table 8.8 Mains Supply 3x380–480 V AC, P2K2–P7K5

| Type designation | P11K | | P15K | | P18K | | P22K | | P30K | |
|--|----------------------|------|------|------|------|------|----------------------|------|------|------|
| High/normal overload ¹⁾ | HO | NO | HO | NO | HO | NO | HO | NO | HO | NO |
| Typical shaft output [kW] | 7.5 | 11 | 11 | 15 | 15 | 18.5 | 22.0 | 22.0 | 22.0 | 30 |
| Typical shaft output at 460 V [hp] | 10 | 15 | 15 | 20 | 20 | 25 | 30 | 30 | 30 | 40 |
| Protection rating IP20/Chassis ⁷⁾ | B3 | | B3 | | B3 | | B4 | | | B4 |
| Protection rating IP21/Type 1 | B1 | | B1 | | B1 | | B2 | | B2 | |
| Protection rating IP55/Type 12 | B1 | | B1 | | B1 | | B2 | | B2 | |
| Protection rating IP66/NEMA 4X | B1 | | B1 | | B1 | | B2 | | B2 | |
| Output current | | | | | | | | | | |
| Continuous (3x380–440 V) [A] | – | 24 | 24 | 32 | 32 | 37.5 | 37.5 | 44 | 44 | 61 |
| Intermittent (60 s overload) (3x380–440 V) [A] | – | 26.4 | 38.4 | 35.2 | 51.2 | 41.3 | 60 | 48.4 | 70.4 | 67.1 |
| Continuous (3x441–480 V) [A] | – | 21 | 21 | 27 | 27 | 34 | 34 | 40 | 40 | 52 |
| Intermittent (60 s overload) (3x441–480 V) [A] | – | 23.1 | 33.6 | 29.7 | 43.2 | 37.4 | 54.4 | 44 | 64 | 61.6 |
| Continuous kVA at 400 V [kVA] | – | 16.6 | 16.6 | 22.2 | 22.2 | 26 | 26 | 30.5 | 30.5 | 42.3 |
| Continuous kVA at 460 V [kVA] | – | 16.7 | 16.7 | 21.5 | 21.5 | 27.1 | 27.1 | 31.9 | 31.9 | 41.4 |
| Maximum input current | | | | | | | | | | |
| Continuous (3x380–440 V) [A] | – | 22 | 22 | 29 | 29 | 34 | 34 | 40 | 40 | 55 |
| Intermittent (60 s overload) (3x380–440 V) [A] | – | 24.2 | 35.2 | 31.9 | 46.4 | 37.4 | 54.4 | 44 | 64 | 60.5 |
| Continuous (3x441–480 V) [A] | – | 19 | 19 | 25 | 25 | 31 | 31 | 36 | 36 | 47 |
| Intermittent (60 s overload) (3x441–480 V) [A] | – | 20.9 | 30.4 | 27.5 | 40 | 34.1 | 49.6 | 39.6 | 57.6 | 51.7 |
| Maximum pre-fuses [A] | – | 63 | | 63 | | 63 | | 63 | | 80 |
| Additional specifications | | | | | | | | | | |
| Protection ratings IP21, IP55, IP66 maximum cable cross-section ²⁾ for mains, brake, and load sharing [mm ²] ([AWG]) | 16, 10, 16 (6, 8, 6) | | | | | | 35, –, – (2, –, –) | | | |
| Protection ratings IP21, IP55, IP66 maximum cable cross-section ²⁾ for motor [mm ²] ([AWG]) | 10, 10,– (8, 8,–) | | | | | | 35, 25, 25 (2, 4, 4) | | | |
| Protection rating IP20 maximum cable cross-section ²⁾ for mains, brake, motor, and load sharing [mm ²] ([AWG]) | 10, 10,– (8, 8,–) | | | | | | 35, –, – (2, –, –) | | | |
| Maximum cable cross-section ²⁾ for disconnect [mm ²] ([AWG]) | 16, 10, 10 (6, 8, 8) | | | | | | | | | |
| Estimated power loss ³⁾ at rated maximum load [W] ⁴⁾ | 291 | 392 | 291 | 392 | 379 | 465 | 444 | 525 | 547 | 739 |
| Efficiency ⁵⁾ | 0.98 | | 0.98 | | 0.98 | | 0.98 | | 0.98 | |

Table 8.9 Mains Supply 3x380–480 V AC, P11K–P30K

| Type designation | P37K | | P45K | | P55K | | P75K | | P90K | |
|---|--------|------|-------------------------|------|--------|------|-------------------------------|------|--|------|
| High/normal overload ¹⁾ | HO | NO | HO | NO | HO | NO | HO | NO | HO | NO |
| Typical shaft output [kW] | 30 | 37 | 37 | 45 | 45 | 55 | 55 | 75 | 75 | 90 |
| Typical shaft output at 460 V [hp] | 40 | 50 | 50 | 60 | 60 | 75 | 75 | 100 | 100 | 125 |
| Protection rating IP20/Chassis ⁶⁾ | B4 | | C3 | | C3 | | C4 | | C4 | |
| Protection rating IP21/Type 1 | C1 | | C1 | | C1 | | C2 | | C2 | |
| Protection rating IP55/Type 12 | C1 | | C1 | | C1 | | C2 | | C2 | |
| Protection rating IP66/NEMA 4X | C1 | | C1 | | C1 | | C2 | | C2 | |
| Output current | | | | | | | | | | |
| Continuous (3x380–440 V) [A] | 61 | 73 | 73 | 90 | 90 | 106 | 106 | 147 | 147 | 177 |
| Intermittent (60 s overload) (3x380–440 V) [A] | 91.5 | 80.3 | 110 | 99 | 135 | 117 | 159 | 162 | 221 | 195 |
| Continuous (3x441–480 V) [A] | 52 | 65 | 65 | 80 | 80 | 105 | 105 | 130 | 130 | 160 |
| Intermittent (60 s overload) (3x441–480 V) [A] | 78 | 71.5 | 97.5 | 88 | 120 | 116 | 158 | 143 | 195 | 176 |
| Continuous kVA at 400 V [kVA] | 42.3 | 50.6 | 50.6 | 62.4 | 62.4 | 73.4 | 73.4 | 102 | 102 | 123 |
| Continuous kVA at 460 V [kVA] | 41.4 | 51.8 | 51.8 | 63.7 | 63.7 | 83.7 | 83.7 | 104 | 103.6 | 128 |
| Maximum input current | | | | | | | | | | |
| Continuous (3x380–440 V) [A] | 55 | 66 | 66 | 82 | 82 | 96 | 96 | 133 | 133 | 161 |
| Intermittent (60 s overload) (3x380–440 V) [A] | 82.5 | 72.6 | 99 | 90.2 | 123 | 106 | 144 | 146 | 200 | 177 |
| Continuous (3x441–480 V) [A] | 47 | 59 | 59 | 73 | 73 | 95 | 95 | 118 | 118 | 145 |
| Intermittent (60 s overload) (3x441–480 V) [A] | 70.5 | 64.9 | 88.5 | 80.3 | 110 | 105 | 143 | 130 | 177 | 160 |
| Maximum pre-fuses [A] | 100 | | 125 | | 160 | | 250 | | 250 | |
| Additional specifications | | | | | | | | | | |
| Protection rating IP20 maximum cable cross-section for mains and motor [mm ²] ([AWG]) | 35 (2) | | 50 (1) | | 50 (1) | | 150 (300 MCM) | | 150 (300 MCM) | |
| Protection rating IP20 maximum cable cross-section for brake and load sharing [mm ²] ([AWG]) | 35 (2) | | 50 (1) | | 50 (1) | | 95 (4/0) | | 95 (4/0) | |
| Protection ratings IP21, IP55, IP66 maximum cable cross-section for mains and motor [mm ²] ([AWG]) | 50 (1) | | 50 (1) | | 50 (1) | | 150 (300 MCM) | | 150 (300 MCM) | |
| Protection ratings IP21, IP55, IP66 maximum cable cross-section for brake and load sharing [mm ²] ([AWG]) | 50 (1) | | 50 (1) | | 50 (1) | | 95 (3/0) | | 95 (3/0) | |
| Maximum cable cross-section ²⁾ for mains disconnect [mm ²] ([AWG]) | | | 50, 35, 35 (1, 2, 2) | | | | 95, 70, 70 (3/0, 2/0, 2/0) | | 185, 150, 120 (350 MCM, 300 MCM, 4/0) | |
| Estimated power loss ³⁾ at rated maximum load [W] ⁴⁾ | 570 | 698 | 697 | 843 | 891 | 1083 | 1022 | 1384 | 1232 | 1474 |
| Efficiency ⁵⁾ | 0.98 | | 0.98 | | 0.98 | | 0.98 | | 0.99 | |

Table 8.10 Mains Supply 3x380–480 V AC, P37K–P90K

8.1.5 Mains Supply 3x525–600 V AC

| Type designation | PK75 | | P1K1 | | P1K5 | | P2K2 | |
|--|--|-----|------|-----|------|-----|------|-----|
| | HO | NO | HO | NO | HO | NO | HO | NO |
| High/normal overload ¹⁾ | HO | NO | HO | NO | HO | NO | HO | NO |
| Typical shaft output [kW] | 0.75 | | 1.1 | | 1.5 | | 2.2 | |
| Typical shaft output [hp] | 1 | | 1.5 | | 2 | | 3 | |
| Protection rating IP20/Chassis | A3 | | A3 | | A3 | | A3 | |
| Protection rating IP21/Type 1 | A3 | | A3 | | A3 | | A3 | |
| Protection rating IP55/Type 12 | A5 | | A5 | | A5 | | A5 | |
| Output current | | | | | | | | |
| Continuous (3x525–550 V) [A] | 1.8 | | 2.6 | | 2.9 | | 4.1 | |
| Intermittent (3x525–550 V) [A] | 2.7 | 2.0 | 3.9 | 2.9 | 4.4 | 3.2 | 6.2 | 4.5 |
| Continuous (3x551–600 V) [A] | 1.7 | | 2.4 | | 2.7 | | 3.9 | |
| Intermittent (3x551–600 V) [A] | 2.6 | 1.9 | 3.6 | 2.6 | 4.1 | 3.0 | 5.9 | 4.3 |
| Continuous kVA at 550 V [kVA] | 1.7 | | 2.5 | | 2.8 | | 3.9 | |
| Continuous kVA at 550 V [kVA] | 1.7 | | 2.4 | | 2.7 | | 3.9 | |
| Maximum input current | | | | | | | | |
| Continuous (3x525–600 V) [A] | 1.7 | | 2.4 | | 2.7 | | 4.1 | |
| Intermittent (3x525–600 V) [A] | 2.6 | 1.9 | 3.6 | 2.6 | 4.1 | 3.0 | 6.2 | 4.5 |
| Maximum pre-fuses [A] | 10 | | 10 | | 10 | | 20 | |
| Additional specifications | | | | | | | | |
| Maximum cable cross-section ²⁾ for mains, motor, brake, and load sharing [mm ²] ([AWG]) | 4,4,4 (12,12,12) (minimum 0.2 (24)) | | | | | | | |
| Maximum cable cross-section ²⁾ for mains disconnect [mm ²] ([AWG]) | 6,4,4 (10,12,12) | | | | | | | |
| Estimated power loss ³⁾ at rated maximum load [W] ⁴⁾ | 35 | | 50 | | 65 | | 92 | |
| Efficiency ⁵⁾ | 0.97 | | 0.97 | | 0.97 | | 0.97 | |

Table 8.11 Mains Supply 3x525–600 V AC, PK75–P2K2

| Type designation | P3K0 | | P4K0 | | P5K5 | | P7K5 | |
|--|--|-----|------|-----|------|------|------|------|
| | HO | NO | HO | NO | HO | NO | HO | NO |
| High/normal overload ¹⁾ | HO | NO | HO | NO | HO | NO | HO | NO |
| Typical shaft output [kW] | 3.0 | | 4.0 | | 5.5 | | 7.5 | |
| Typical shaft output [hp] | 4 | | 5 | | 7.5 | | 10 | |
| Protection rating IP20/Chassis Protection rating IP21/Type 1 | A2 | | A2 | | A3 | | A3 | |
| IP55/Type 12 | A5 | | A5 | | A5 | | A5 | |
| Output current | | | | | | | | |
| Continuous (3x525–550 V) [A] | 5.2 | | 6.4 | | 9.5 | | 11.5 | |
| Intermittent (3x525–550 V) [A] | 7.8 | 5.7 | 9.6 | 7.0 | 14.3 | 10.5 | 17.3 | 12.7 |
| Continuous (3x551–600 V) [A] | 4.9 | | 6.1 | | 9.0 | | 11.0 | |
| Intermittent (3x551–600 V) [A] | 7.4 | 5.4 | 9.2 | 6.7 | 13.5 | 9.9 | 16.5 | 12.1 |
| Continuous kVA at 550 V [kVA] | 5.0 | | 6.1 | | 9.0 | | 11.0 | |
| Continuous kVA at 550 V [kVA] | 4.9 | | 6.1 | | 9.0 | | 11.0 | |
| Maximum input current | | | | | | | | |
| Continuous (3x525–600 V) [A] | 5.2 | | 5.8 | | 8.6 | | 10.4 | |
| Intermittent (3x525–600 V) [A] | 7.8 | 5.7 | 8.7 | 6.4 | 12.9 | 9.5 | 15.6 | 11.4 |
| Maximum pre-fuses [A] | 20 | | 20 | | 32 | | 32 | |
| Additional specifications | | | | | | | | |
| Maximum cable cross-section ²⁾ for mains, motor, brake, and load sharing [mm ²] ([AWG]) | 4,4,4 (12,12,12) (minimum 0.2 (24)) | | | | | | | |
| Maximum cable cross-section ²⁾ for mains disconnect [mm ²] ([AWG]) | 6,4,4 (10,12,12) | | | | | | | |
| Estimated power loss ³⁾ at rated maximum load [W] ⁴⁾ | 122 | | 145 | | 195 | | 261 | |
| Efficiency ⁵⁾ | 0.97 | | 0.97 | | 0.97 | | 0.97 | |

Table 8.12 Mains Supply 3x525–600 V AC, P3K0–P7K5

| Type designation | P11K | | P15K | | P18K | | P22K | | P30K | | P37K | |
|---|-------------------------|------|------|------|------|------|-------------------------|------|------|------|------|------|
| | HO | NO | HO | NO | HO | NO | HO | NO | HO | NO | HO | NO |
| High/normal overload ¹⁾ | HO | NO | HO | NO | HO | NO | HO | NO | HO | NO | HO | NO |
| Typical shaft output [kW] | 7.5 | 11 | 11 | 15 | 15 | 18.5 | 18.5 | 22 | 22 | 30 | 30 | 37 |
| Typical shaft output [hp] | 10 | 15 | 15 | 20 | 20 | 25 | 25 | 30 | 30 | 40 | 40 | 50 |
| Protection rating IP20/ Chassis | B3 | | B3 | | B3 | | B4 | | B4 | | B4 | |
| Protection rating IP21/ Type 1 Protection rating IP55/ Type 12 Protection rating IP66/ NEMA 4X | B1 | | B1 | | B1 | | B2 | | B2 | | C1 | |
| Output current | | | | | | | | | | | | |
| Continuous (3x525–550 V) [A] | 11.5 | 19 | 19 | 23 | 23 | 28 | 28 | 36 | 36 | 43 | 43 | 54 |
| Intermittent (3x525–550 V) [A] | 18.4 | 21 | 30 | 25 | 37 | 31 | 45 | 40 | 58 | 47 | 65 | 59 |
| Continuous (3x551–600 V) [A] | 11 | 18 | 18 | 22 | 22 | 27 | 27 | 34 | 34 | 41 | 41 | 52 |
| Intermittent (3x551–600 V) [A] | 17.6 | 20 | 29 | 24 | 35 | 30 | 43 | 37 | 54 | 45 | 62 | 57 |
| Continuous kVA at 550 V [kVA] | 11 | 18.1 | 18.1 | 21.9 | 21.9 | 26.7 | 26.7 | 34.3 | 34.3 | 41.0 | 41.0 | 51.4 |
| Continuous kVA at 575 V [kVA] | 11 | 17.9 | 17.9 | 21.9 | 21.9 | 26.9 | 26.9 | 33.9 | 33.9 | 40.8 | 40.8 | 51.8 |
| Maximum input current | | | | | | | | | | | | |
| Continuous at 550 V [A] | 10.4 | 17.2 | 17.2 | 20.9 | 20.9 | 25.4 | 25.4 | 32.7 | 32.7 | 39 | 39 | 49 |
| Intermittent at 550 V [A] | 16.6 | 19 | 28 | 23 | 33 | 28 | 41 | 36 | 52 | 43 | 59 | 54 |
| Continuous at 575 V [A] | 9.8 | 16 | 16 | 20 | 20 | 24 | 24 | 31 | 31 | 37 | 37 | 47 |
| Intermittent at 575 V [A] | 15.5 | 17.6 | 26 | 22 | 32 | 27 | 39 | 34 | 50 | 41 | 56 | 52 |
| Maximum pre-fuses [A] | 40 | | 40 | | 50 | | 60 | | 80 | | 100 | |
| Additional specifications | | | | | | | | | | | | |
| Protection rating IP20, maximum cable cross- section ²⁾ for mains, brake, motor, and load sharing [mm ²] ([AWG]) | 10, 10,- (8, 8,-) | | | | | | 35,-,- (2,-,-) | | | | | |
| Protection ratings IP21, IP55, IP66 maximum cable cross-section ²⁾ for mains, brake, and load sharing [mm ²] ([AWG]) | 16, 10, 10 (6, 8, 8) | | | | | | 35,-,- (2,-,-) | | | | | |
| Protection ratings IP21, IP55, IP66 maximum cable cross-section ²⁾ for motor [mm ²] ([AWG]) | 10, 10,- (8, 8,-) | | | | | | 35, 25, 25 (2, 4, 4) | | | | | |
| Maximum cable cross- section ²⁾ for mains disconnect [mm ²] ([AWG]) | 16, 10, 10 (6, 8, 8) | | | | | | 50, 35, 35 (1, 2, 2) | | | | | |
| Estimated power loss ³⁾ at rated maximum load [W] ⁴⁾ | 220 | 300 | 220 | 300 | 300 | 370 | 370 | 440 | 440 | 600 | 600 | 740 |
| Efficiency ⁵⁾ | 0.98 | | 0.98 | | 0.98 | | 0.98 | | 0.98 | | 0.98 | |

Table 8.13 Mains supply 3x525–600 V AC, P11K–P37K

| Type designation | P45K | | P55K | | P75K | | P90K | |
|---|-------------------------|------|------|------|-------------------------------|------|---|-------|
| High/normal overload ¹⁾ | HO | NO | HO | NO | HO | NO | HO | NO |
| Typical shaft output [kW] | 37 | 45 | 45 | 55 | 55 | 75 | 75 | 90 |
| Typical shaft output [hp] | 50 | 60 | 60 | 75 | 75 | 100 | 100 | 125 |
| Protection rating IP20/Chassis | C3 | | C3 | | C4 | | C4 | |
| Protection rating IP21/Type 1 | C1 | | C1 | | C2 | | C2 | |
| Protection rating IP55/Type 12 | | | | | | | | |
| Protection rating IP66/NEMA 4X | | | | | | | | |
| Output current | | | | | | | | |
| Continuous (3x525–550 V) [A] | 54 | 65 | 65 | 87 | 87 | 105 | 105 | 137 |
| Intermittent (3x525–550 V) [A] | 81 | 72 | 98 | 96 | 131 | 116 | 158 | 151 |
| Continuous (3x525–600 V) [A] | 52 | 62 | 62 | 83 | 83 | 100 | 100 | 131 |
| Intermittent (3x525–600 V) [A] | 78 | 68 | 93 | 91 | 125 | 110 | 150 | 144 |
| Continuous kVA at 525 V [kVA] | 51.4 | 61.9 | 61.9 | 82.9 | 82.9 | 100 | 100.0 | 130.5 |
| Continuous kVA at 575 V [kVA] | 51.8 | 61.7 | 61.7 | 82.7 | 82.7 | 99.6 | 99.6 | 130.5 |
| Maximum input current | | | | | | | | |
| Continuous at 550 V [A] | 49 | 59 | 59 | 78.9 | 78.9 | 95.3 | 95.3 | 124.3 |
| Intermittent at 550 V [A] | 74 | 65 | 89 | 87 | 118 | 105 | 143 | 137 |
| Continuous at 575 V [A] | 47 | 56 | 56 | 75 | 75 | 91 | 91 | 119 |
| Intermittent at 575 V [A] | 70 | 62 | 85 | 83 | 113 | 100 | 137 | 131 |
| Maximum pre-fuses [A] | 150 | | 160 | | 225 | | 250 | |
| Additional specifications | | | | | | | | |
| Protection rating IP20 maximum cable cross-section for mains and motor [mm ²] ([AWG]) | 50 (1) | | | | 150 (300 MCM) | | | |
| Protection rating IP20 maximum cable cross-section for brake and load sharing [mm ²] ([AWG]) | 50 (1) | | | | 95 (4/0) | | | |
| Protection ratings IP21, IP55, IP66 maximum cable cross-section for mains and motor [mm ²] ([AWG]) | 50 (1) | | | | 150 (300 MCM) | | | |
| Protection ratings IP21, IP55, IP66 maximum cable cross-section for brake and load sharing [mm ²] ([AWG]) | 50 (1) | | | | 95 (4/0) | | | |
| Maximum cable cross-section ²⁾ for mains disconnect [mm ²] ([AWG]) | 50, 35, 35 (1, 2, 2) | | | | 95, 70, 70 (3/0, 2/0, 2/0) | | 185, 150, 120 (350 MCM, 300 MCM, 4/0) | |
| Estimated power loss ³⁾ at rated maximum load [W] ⁴⁾ | 740 | 900 | 900 | 1100 | 1100 | 1500 | 1500 | 1800 |
| Efficiency ⁵⁾ | 0.98 | | 0.98 | | 0.98 | | 0.98 | |

Table 8.14 Mains supply 3x525–600 V AC, P45K–P90K

8.1.6 Mains Supply 3x525–690 V AC

| Type designation | P1K1 | | P1K5 | | P2K2 | | P3K0 | | P4K0 | | P5K5 | | P7K5 | |
|--|--|-----|------|-----|------|-----|------|-----|------|-----|------|-----|------|------|
| | HO | NO | HO | NO | HO | NO | HO | NO | HO | NO | HO | NO | HO | NO |
| High/normal overload ¹⁾ | | | | | | | | | | | | | | |
| Typical shaft output [kW] | 1.1 | | 1.5 | | 2.2 | | 3.0 | | 4.0 | | 5.5 | | 7.5 | |
| Typical shaft output [hp] | 1.5 | | 2 | | 3 | | 4 | | 5 | | 7.5 | | 10 | |
| IP20/Chassis | A3 | | A3 | | A3 | | A3 | | A3 | | A3 | | A3 | |
| Output current | | | | | | | | | | | | | | |
| Continuous (3x525–550 V) [A] | 2.1 | | 2.7 | | 3.9 | | 4.9 | | 6.1 | | 9.0 | | 11.0 | |
| Intermittent (3x525–550 V) [A] | 3.2 | 2.3 | 4.1 | 3.0 | 5.9 | 4.3 | 7.4 | 5.4 | 9.2 | 6.7 | 13.5 | 9.9 | 16.5 | 12.1 |
| Continuous (3x551–690 V) [A] | 1.6 | | 2.2 | | 3.2 | | 4.5 | | 5.5 | | 7.5 | | 10.0 | |
| Intermittent (3x551–690 V) [A] | 2.4 | 1.8 | 3.3 | 2.4 | 4.8 | 3.5 | 6.8 | 5.0 | 8.3 | 6.1 | 11.3 | 8.3 | 15.0 | 11.0 |
| Continuous kVA at 525 V [kVA] | 1.9 | | 2.5 | | 3.5 | | 4.5 | | 5.5 | | 8.2 | | 10.0 | |
| Continuous kVA at 690 V [kVA] | 1.9 | | 2.6 | | 3.8 | | 5.4 | | 6.6 | | 9.0 | | 12.0 | |
| Maximum input current | | | | | | | | | | | | | | |
| Continuous (3x525–550 V) [A] | 1.9 | | 2.4 | | 3.5 | | 4.4 | | 5.5 | | 8.1 | | 9.9 | |
| Intermittent (3x525–550 V) [A] | 2.9 | 2.1 | 3.6 | 2.6 | 5.3 | 3.9 | 6.6 | 4.8 | 8.3 | 6.1 | 12.2 | 8.9 | 14.9 | 10.9 |
| Continuous (3x551–690 V) [A] | 1.4 | | 2.0 | | 2.9 | | 4.0 | | 4.9 | | 6.7 | | 9.0 | |
| Intermittent (3x551–690 V) [A] | 2.1 | 1.5 | 3.0 | 2.2 | 4.4 | 3.2 | 6.0 | 4.4 | 7.4 | 5.4 | 10.1 | 7.4 | 13.5 | 9.9 |
| Additional specifications | | | | | | | | | | | | | | |
| Maximum cable cross-section ²⁾ for mains, motor, brake, and load sharing [mm ²] ([AWG]) | 4, 4, 4 (12, 12, 12) (min. 0.2 (24)) | | | | | | | | | | | | | |
| Maximum cable cross-section ²⁾ for mains disconnect [mm ²] ([AWG]) | 6, 4, 4 (10, 12, 12) | | | | | | | | | | | | | |
| Estimated power loss ³⁾ at rated maximum load [W] ⁴⁾ | 44 | | 60 | | 88 | | 120 | | 160 | | 220 | | 300 | |
| Efficiency ⁵⁾ | 0.96 | | 0.96 | | 0.96 | | 0.96 | | 0.96 | | 0.96 | | 0.96 | |

Table 8.15 A3 Enclosure, Mains Supply 3x525–690 V AC IP20/Protected Chassis, P1K1–P7K5

| Type designation | P11K | | P15K | | P18K | | P22K | | P30K | |
|--|-------------------------|------|------|------|------|------|------|------|------|------|
| High/normal overload ¹⁾ | HO | NO | HO | NO | HO | NO | HO | NO | HO | NO |
| Typical shaft output at 550 V [kW] | 5.9 | 7.5 | 7.5 | 11 | 11 | 15 | 15 | 18.5 | 18.5 | 22 |
| Typical shaft output at 550 V [hp] | 7.5 | 10 | 10 | 15 | 15 | 20 | 20 | 25 | 25 | 30 |
| Typical shaft output at 690 V [kW] | 7.5 | 11 | 11 | 15 | 15 | 18.5 | 18.5 | 22 | 22 | 30 |
| Typical shaft output at 690 V [hp] | 10 | 15 | 15 | 20 | 20 | 25 | 25 | 30 | 30 | 40 |
| IP20/Chassis | B4 | | B4 | | B4 | | B4 | | B4 | |
| IP21/Type 1 | | | | | | | | | | |
| IP55/Type 12 | B2 | | B2 | | B2 | | B2 | | B2 | |
| Output current | | | | | | | | | | |
| Continuous (3x525–550 V) [A] | 11 | 14 | 14.0 | 19.0 | 19.0 | 23.0 | 23.0 | 28.0 | 28.0 | 36.0 |
| Intermittent (60 s overload) (3x525–550 V) [A] | 17.6 | 15.4 | 22.4 | 20.9 | 30.4 | 25.3 | 36.8 | 30.8 | 44.8 | 39.6 |
| Continuous (3x551–690 V) [A] | 10 | 13 | 13.0 | 18.0 | 18.0 | 22.0 | 22.0 | 27.0 | 27.0 | 34.0 |
| Intermittent (60 s overload) (3x551–690 V) [A] | 16 | 14.3 | 20.8 | 19.8 | 28.8 | 24.2 | 35.2 | 29.7 | 43.2 | 37.4 |
| Continuous kVA at 550 V [kVA] | 10 | 13.3 | 13.3 | 18.1 | 18.1 | 21.9 | 21.9 | 26.7 | 26.7 | 34.3 |
| Continuous kVA at 690 V [kVA] | 12 | 15.5 | 15.5 | 21.5 | 21.5 | 26.3 | 26.3 | 32.3 | 32.3 | 40.6 |
| Maximum input current | | | | | | | | | | |
| Continuous at 550 V [A] | 9.9 | 15 | 15.0 | 19.5 | 19.5 | 24.0 | 24.0 | 29.0 | 29.0 | 36.0 |
| Intermittent (60 s overload) at 550 V [A] | 15.8 | 16.5 | 23.2 | 21.5 | 31.2 | 26.4 | 38.4 | 31.9 | 46.4 | 39.6 |
| Continuous (at 690 V) [A] | 9 | 14.5 | 14.5 | 19.5 | 19.5 | 24.0 | 24.0 | 29.0 | 29.0 | 36.0 |
| Intermittent (60 s overload) at 690 V [A] | 14.4 | 16 | 23.2 | 21.5 | 31.2 | 26.4 | 38.4 | 31.9 | 46.4 | 39.6 |
| Additional specifications | | | | | | | | | | |
| Maximum cable cross-section ²⁾ for mains, motor, brake, and load sharing [mm ²] ([AWG]) | 35, 25, 25 (2, 4, 4) | | | | | | | | | |
| Maximum cable cross-section ²⁾ for mains disconnect [mm ²] ([AWG]) | 16,10,10 (6, 8, 8) | | | | | | | | | |
| Estimated power loss ³⁾ at rated maximum load [W] ⁴⁾ | 150 | 220 | 150 | 220 | 220 | 300 | 300 | 370 | 370 | 440 |
| Efficiency ⁵⁾ | 0.98 | | 0.98 | | 0.98 | | 0.98 | | 0.98 | |

Table 8.16 B2/B4 Enclosure, Mains Supply 3x525–690 V AC IP20/IP21/IP55 – Chassis/NEMA 1/NEMA 12, P11K–P22K

| Type designation | P37K | | P45K | | P55K | | P75K/N75K ⁸⁾ | | P90K/N90K ⁸⁾ | |
|---|---------------|------|------|------|------|------|---------------------------------------|------|-------------------------|-------|
| High/normal overload ¹⁾ | HO | NO | HO | NO | HO | NO | HO | NO | HO | NO |
| Typical shaft output at 550 V [kW] | 22 | 30 | 30 | 37 | 37 | 45 | 45 | 55 | 55 | 75 |
| Typical shaft output at 550 V [hp] | 30 | 40 | 40 | 50 | 50 | 60 | 60 | 75 | 75 | 100 |
| Typical shaft output at 690 V [kW] | 30 | 37 | 37 | 45 | 45 | 55 | 55 | 75 | 75 | 90 |
| Typical shaft output at 690 V [hp] | 40 | 50 | 50 | 60 | 60 | 75 | 75 | 100 | 199 | 125 |
| IP20/Chassis | B4 | | C3 | | C3 | | D3h | | D3h | |
| IP21/Type 1 | | | | | | | | | | |
| IP55/Type 12 | C2 | | C2 | | C2 | | C2 | | C2 | |
| Output current | | | | | | | | | | |
| Continuous (3x525–550 V) [A] | 36.0 | 43.0 | 43.0 | 54.0 | 54.0 | 65.0 | 65.0 | 87.0 | 87.0 | 105 |
| Intermittent (60 s overload) (3x525–550 V) [A] | 54.0 | 47.3 | 64.5 | 59.4 | 81.0 | 71.5 | 97.5 | 95.7 | 130.5 | 115.5 |
| Continuous (3x551–690 V) [A] | 34.0 | 41.0 | 41.0 | 52.0 | 52.0 | 62.0 | 62.0 | 83.0 | 83.0 | 100 |
| Intermittent (60 s overload) (3x551–690 V) [A] | 51.0 | 45.1 | 61.5 | 57.2 | 78.0 | 68.2 | 93.0 | 91.3 | 124.5 | 110 |
| Continuous kVA at 550 V [kVA] | 34.3 | 41.0 | 41.0 | 51.4 | 51.4 | 61.9 | 61.9 | 82.9 | 82.9 | 100 |
| Continuous kVA at 690 V [kVA] | 40.6 | 49.0 | 49.0 | 62.1 | 62.1 | 74.1 | 74.1 | 99.2 | 99.2 | 119.5 |
| Maximum input current | | | | | | | | | | |
| Continuous at 550 V [A] | 36.0 | 49.0 | 49.0 | 59.0 | 59.0 | 71.0 | 71.0 | 87.0 | 87.0 | 99.0 |
| Intermittent (60 s overload) at 550 V [A] | 54.0 | 53.9 | 72.0 | 64.9 | 87.0 | 78.1 | 105.0 | 95.7 | 129 | 108.9 |
| Continuous at 690 V [A] | 36.0 | 48.0 | 48.0 | 58.0 | 58.0 | 70.0 | 70.0 | 86.0 | – | – |
| Intermittent (60 s overload) at 690 V [A] | 54.0 | 52.8 | 72.0 | 63.8 | 87.0 | 77.0 | 105 | 94.6 | – | – |
| Additional specifications | | | | | | | | | | |
| Maximum cable cross-section for mains and motor [mm ²] ([AWG]) | 150 (300 MCM) | | | | | | | | | |
| Maximum cable cross-section for brake and load sharing [mm ²] ([AWG]) | 95 (3/0) | | | | | | | | | |
| Maximum cable cross-section ²⁾ for mains disconnect [mm ²] ([AWG]) | 95 (3/0) | | | | | | 185, 150, 120 (350 MCM, 300 MCM, 4/0) | | – | |
| Estimated power loss ³⁾ at rated maximum load [W] ⁴⁾ | 600 | 740 | 740 | 900 | 900 | 1100 | 1100 | 1500 | 1500 | 1800 |
| Efficiency ⁵⁾ | 0.98 | | 0.98 | | 0.98 | | 0.98 | | 0.98 | |

Table 8.17 B4, C2, C3 Enclosure, Mains Supply 3x525–690 V AC IP20/IP21/IP55 – Chassis/NEMA1/NEMA 12, P30K–P75K

For fuse ratings see chapter 8.8 Fuses and Circuit Breakers.

1) High overload=150% or 160% torque for a duration of 60 s. Normal overload=110% torque for a duration of 60 s.

2) The 3 values for the maximum cable cross-section are for single core, flexible wire and flexible wire with sleeve, respectively.

3) Applies for dimensioning of frequency converter cooling. If the switching frequency is higher than the default setting, the power losses may increase. LCP and typical control card power consumptions are included. For power loss data according to EN 50598–2, refer to www.danfoss.com/vltenergyefficiency.

4) Efficiency measured at nominal current. For energy efficiency class see chapter 8.4.1 Ambient Conditions. For part load losses see www.danfoss.com/vltenergyefficiency.

5) Measured using 5 m screened motor cables at rated load and rated frequency.

6) Enclosure sizes A2+A3 can be converted to IP21 using a conversion kit. See also Mechanical mounting and IP21/Type 1 Enclosure kit in the design guide.

7) Enclosure sizes B3+B4 and C3+C4 can be converted to IP21 using a conversion kit. See also Mechanical mounting and IP21/Type 1 Enclosure kit in the design guide.

8) Enclosure sizes for N75K, N90K are D3h for IP20/Chassis, and D5h for IP54/Type 12.

9) Two wires are required.

10) Variant not available in IP21.

8.2 Mains Supply

Mains supply (L1, L2, L3)

| | |
|----------------|---------------------|
| Supply voltage | 200–240 V \pm 10% |
| Supply voltage | 380–480 V \pm 10% |
| Supply voltage | 525–600 V \pm 10% |
| Supply voltage | 525–690 V \pm 10% |

Mains voltage low/mains drop-out:

During low mains voltage or a mains drop-out, the frequency converter continues until the intermediate circuit voltage drops below the minimum stop level. Typically this corresponds to 15% below the lowest rated supply voltage of the frequency converter. Power-up and full torque cannot be expected at mains voltage <10% below the lowest rated supply voltage of the frequency converter.

| | |
|------------------|-----------------|
| Supply frequency | 50/60 Hz +4/-6% |
|------------------|-----------------|

The frequency converter power supply is tested in accordance with IEC61000-4-28, 50 Hz +4/-6%.

| | |
|--|---|
| Maximum imbalance temporary between mains phases | 3.0% of rated supply voltage |
| True power factor (λ) | \geq 0.9 nominal at rated load |
| Displacement power factor ($\cos\phi$) near unity | (>0.98) |
| Switching on input supply L1, L2, L3 (power-ups) \leq 7.5 kW | maximum 2 times/min. |
| Switching on input supply L1, L2, L3 (power-ups) 11–90 kW | maximum 1 time/min. |
| Environment according to EN 60664-1 | overvoltage category III/pollution degree 2 |

The unit is suitable for use on a circuit capable of delivering not more than 100000 RMS symmetrical Amperes, 240/480/600/690 V maximum.

8

8.3 Motor Output and Motor Data

Motor output (U, V, W)

| | |
|---------------------|--------------------------|
| Output voltage | 0–100% of supply voltage |
| Output frequency | 0–590 Hz ¹⁾ |
| Switching on output | Unlimited |
| Ramp times | 1–3600 s |

1) Dependent on power size.

Torque characteristics, normal overload

| | |
|-----------------------------------|---|
| Starting torque (constant torque) | maximum 110% for 1 minute, once in 10 minutes ²⁾ |
| Overload torque (constant torque) | maximum 110% for 1 minute, once in 10 minutes ²⁾ |

Torque characteristics, high overload

| | |
|-----------------------------------|---|
| Starting torque (constant torque) | maximum 150/160% for 1 minute, once in 10 minutes ²⁾ |
| Overload torque (constant torque) | maximum 150/160% for 1 minute, once in 10 minutes ²⁾ |

2) Percentage relates to the nominal torque of the frequency converter, dependent on power size.

8.4 Ambient Conditions

Environment

| | |
|---|---|
| Enclosure size A | IP20/Chassis, IP21/Type 1, IP55/Type 12, IP66/Type 4X |
| Enclosure size B1/B2 | IP21/Type 1, IP55/Type 12, IP66/Type 4X |
| Enclosure size B3/B4 | IP20/Chassis |
| Enclosure size C1/C2 | IP21/Type 1, IP55/Type 12, IP66/Type 4X |
| Enclosure size C3/C4 | IP20/Chassis |
| Enclosure kit available ≤ enclosure size A | IP21/TYP E 1/IP4X top |
| Vibration test enclosure A/B/C | 1.0 g |
| Maximum relative humidity | 5–95% (IEC 721-3-3; Class 3K3 (non-condensing) during operation |
| Aggressive environment (IEC 721-3-3), uncoated | class 3C2 |
| Aggressive environment (IEC 721-3-3), coated | class 3C3 |
| Test method according to IEC 60068-2-43 H2S (10 days) | |
| Ambient temperature | Maximum 50 °C |

Derating for high ambient temperature, see section on special conditions in the Design Guide.

| | |
|---|------------------|
| Minimum ambient temperature during full-scale operation | 0 °C |
| Minimum ambient temperature at reduced performance | -10 °C |
| Temperature during storage/transport | -25 to +65/70 °C |
| Maximum altitude above sea level without derating | 1000 m |
| Maximum altitude above sea level with derating | 3000 m |

Derating for high altitude, see section on special conditions in the Design Guide.

| | |
|---------------------------------------|------------|
| EMC standards, Emission | EN 61800-3 |
| EMC standards, Immunity | EN 61800-3 |
| Energy efficiency class ¹⁾ | IE2 |

1) Determined according to EN50598-2 at:

- Rated load
- 90% rated frequency
- Switching frequency factory setting
- Switching pattern factory setting

8.5 Cable Specifications

| | |
|---|---|
| Maximum motor cable length, screened/armoured | 150 m |
| Maximum motor cable length, unscreened/unarmoured | 300 m |
| Maximum cross section to motor, mains, load sharing and brake ¹⁾ | |
| Maximum cross section to control terminals, rigid wire | 1.5 mm ² /16 AWG (2 x 0.75 mm ²) |
| Maximum cross section to control terminals, flexible cable | 1 mm ² /18 AWG |
| Maximum cross section to control terminals, cable with enclosed core | 0.5 mm ² /20 AWG |
| Minimum cross section to control terminals | 0.25 mm ² |

1) See electrical data tables in chapter 8.1 Electrical Data for more information.

It is mandatory to ground the mains connection properly using T95 (PE) of the frequency converter. The ground connection cable cross section must be at least 10 mm² or 2 rated mains wires terminated separately according to EN 50178. See also chapter 4.3.1 Grounding. Use unscreened cable.

8.6 Control Input/Output and Control Data

Control card, RS485 serial communication

| | |
|--------------------|--------------------------------|
| Terminal number | 68 (PTX+, RX+), 69 (NTX-, RX-) |
| Terminal number 61 | common for terminals 68 and 69 |

The RS485 serial communication circuit is functionally separated from other central circuits and galvanically isolated from the supply voltage (PELV).

Analog inputs

| | |
|------------------------------|----------------------------------|
| Number of analog inputs | 2 |
| Terminal number | 53, 54 |
| Modes | voltage or current |
| Mode select | switches S201 and S202 |
| Voltage mode | switch S201/S202 = OFF (U) |
| Voltage level | 0-10 V (scaleable) |
| Input resistance, R_i | approximately 10 k Ω |
| Maximum voltage | ± 20 V |
| Current mode | switch S201/S202=On (I) |
| Current level | 0/4-20 mA (scaleable) |
| Input resistance, R_i | approximately 200 Ω |
| Maximum current | 30 mA |
| Resolution for analog inputs | 10 bit (+ sign) |
| Accuracy of analog inputs | maximum error 0.5% of full scale |
| Bandwidth | 200 Hz |

The analog inputs are galvanically isolated from the supply voltage (PELV) and other high-voltage terminals.

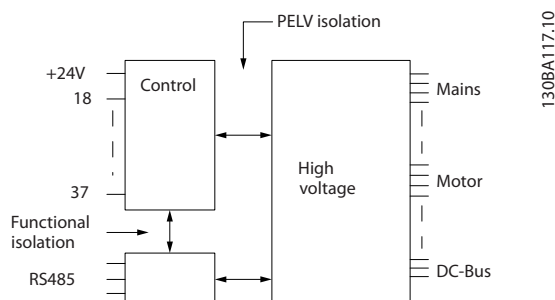

Illustration 8.1 PELV Isolation of Analog Inputs

Analog output

| | |
|--|----------------------------------|
| Number of programmable analog outputs | 1 |
| Terminal number | 42 |
| Current range at analog output | 0/4–20 mA |
| Maximum resistor load to common at analog output | 500 Ω |
| Accuracy on analog output | maximum error 0.8% of full scale |
| Resolution on analog output | 8 bit |

The analog output is galvanically isolated from the supply voltage (PELV) and other high-voltage terminals.

Digital inputs

| | |
|------------------------------|---|
| Programmable digital inputs | 4 (6) |
| Terminal number | 18, 19, 27 ¹⁾ , 29 ¹⁾ , 32, 33, |
| Logic | PNP or NPN |
| Voltage level | 0–24 V DC |
| Voltage level, logic 0 PNP | <5 V DC |
| Voltage level, logic 1 PNP | >10 V DC |
| Voltage level, logic 0 NPN | >19 V DC |
| Voltage level, logic '1' NPN | <14 V DC |
| Maximum voltage on input | 28 V DC |
| Input resistance, R_i | approximately 4 k Ω |

All digital inputs are galvanically isolated from the supply voltage (PELV) and other high-voltage terminals.

1) Terminals 27 and 29 can also be programmed as output.

| | |
|--|----------------------------------|
| Digital output | |
| Programmable digital/pulse outputs | 2 |
| Terminal number | 27, 29 ¹⁾ |
| Voltage level at digital/frequency output | 0–24 V |
| Maximum output current (sink or source) | 40 mA |
| Maximum load at frequency output | 1 kΩ |
| Maximum capacitive load at frequency output | 10 nF |
| Minimum output frequency at frequency output | 0 Hz |
| Maximum output frequency at frequency output | 32 kHz |
| Accuracy of frequency output | maximum error 0.1% of full scale |
| Resolution of frequency outputs | 12 bit |

1) Terminal 27 and 29 can also be programmed as input.

The digital output is galvanically isolated from the supply voltage (PELV) and other high-voltage terminals.

| | |
|--------------------------------------|----------------------------------|
| Pulse inputs | |
| Programmable pulse inputs | 2 |
| Terminal number pulse | 29, 33 |
| Maximum frequency at terminal 29, 33 | 110 kHz (push-pull driven) |
| Maximum frequency at terminal 29, 33 | 5 kHz (open collector) |
| Minimum frequency at terminal 29, 33 | 4 Hz |
| Voltage level | see <i>Digital inputs</i> |
| Maximum voltage on input | 28 V DC |
| Input resistance, R _i | approx. 4 kΩ |
| Pulse input accuracy (0.1–1 kHz) | maximum error 0.1% of full scale |

| | |
|-------------------------------------|--------|
| Control card, 24 V DC output | |
| Terminal number | 12, 13 |
| Maximum load | 200 mA |

The 24 V DC supply is galvanically isolated from the supply voltage (PELV), but has the same potential as the analog and digital inputs and outputs.

| | |
|--|---|
| Relay outputs | |
| Programmable relay outputs | 2 |
| Relay 01 terminal number | 1-3 (break), 1-2 (make) |
| Maximum terminal load (AC-1) ¹⁾ on 1-3 (NC), 1-2 (NO) (resistive load) | 240 V AC, 2 A |
| Maximum terminal load (AC-15) ¹⁾ (inductive load @ cosφ 0.4) | 240 V AC, 0.2 A |
| Maximum terminal load (DC-1) ¹⁾ on 1-2 (NO), 1-3 (NC) (resistive load) | 60 V DC, 1 A |
| Maximum terminal load (DC-13) ¹⁾ (inductive load) | 24 V DC, 0.1 A |
| Relay 02 terminal number | 4-6 (break), 4-5 (make) |
| Maximum terminal load (AC-1) ¹⁾ on 4-5 (NO) (resistive load) ^{2) 3)} | 400 V AC, 2 A |
| Maximum terminal load (AC-15) ¹⁾ on 4-5 (NO) (inductive load @ cosφ 0.4) | 240 V AC, 0.2 A |
| Maximum terminal load (DC-1) ¹⁾ on 4-5 (NO) (resistive load) | 80 V DC, 2 A |
| Maximum terminal load (DC-13) ¹⁾ on 4-5 (NO) (inductive load) | 24 V DC, 0.1 A |
| Maximum terminal load (AC-1) ¹⁾ on 4-6 (NC) (resistive load) | 240 V AC, 2 A |
| Maximum terminal load (AC-15) ¹⁾ on 4-6 (NC) (inductive load @ cosφ 0.4) | 240 V AC, 0.2 A |
| Maximum terminal load (DC-1) ¹⁾ on 4-6 (NC) (resistive load) | 50 V DC, 2 A |
| Maximum terminal load (DC-13) ¹⁾ on 4-6 (NC) (inductive load) | 24 V DC, 0.1 A |
| Minimum terminal load on 1-3 (NC), 1-2 (NO), 4-6 (NC), 4-5 (NO) | 24 V DC, 10 mA, 24 V AC, 20 mA |
| Environment according to EN 60664-1 | overvoltage category III/pollution degree 2 |

1) IEC 60947 parts 4 and 5.

The relay contacts are galvanically isolated from the rest of the circuit by reinforced isolation (PELV).

2) Overvoltage category II.

3) UL applications 300 V AC 2 A.

Control card, 10 V DC output

| | |
|-----------------|--------------------|
| Terminal number | 50 |
| Output voltage | 10.5 V \pm 0.5 V |
| Maximum load | 25 mA |

The 10 V DC supply is galvanically isolated from the supply voltage (PELV) and other high-voltage terminals.

Control characteristics

| | |
|---|---|
| Resolution of output frequency at 0–590 Hz | \pm 0.003 Hz |
| System response time (terminals 18, 19, 27, 29, 32, 33) | \leq 2 ms |
| Speed control range (open loop) | 1:100 of synchronous speed |
| Speed accuracy (open loop) | 30–4000 RPM: maximum error of \pm 8 RPM |

All control characteristics are based on a 4-pole asynchronous motor.

Control card performance

| | |
|---------------|------|
| Scan interval | 5 ms |
|---------------|------|

Control card, USB serial communication

| | |
|--------------|--------------------------|
| USB standard | 1.1 (full speed) |
| USB plug | USB type B “device” plug |

Connection to a PC is carried out via a standard host/device USB cable.

The USB connection is galvanically isolated from the supply voltage (PELV) and other high-voltage terminals.

The USB connection is not galvanically isolated from protective earth. Use only an isolated laptop/PC as a connection to the USB connector on the frequency converter, or an isolated USB cable/converter.

8.7 Connection Tightening Torques

| Enclosure | Torque [Nm] | | | | | |
|-----------|---------------------|---------------------|---------------|-------|--------|--------|
| | Mains | Motor | DC connection | Brake | Ground | Ground |
| A2 | 1.8 | 1.8 | 1.8 | 1.8 | 3 | 0.6 |
| A3 | 1.8 | 1.8 | 1.8 | 1.8 | 3 | 0.6 |
| A4 | 1.8 | 1.8 | 1.8 | 1.8 | 3 | 0.6 |
| A5 | 1.8 | 1.8 | 1.8 | 1.8 | 3 | 0.6 |
| B1 | 1.8 | 1.8 | 1.5 | 1.5 | 3 | 0.6 |
| B2 | 4.5 | 4.5 | 3.7 | 3.7 | 3 | 0.6 |
| B3 | 1.8 | 1.8 | 1.8 | 1.8 | 3 | 0.6 |
| B4 | 4.5 | 4.5 | 4.5 | 4.5 | 3 | 0.6 |
| C1 | 10 | 10 | 10 | 10 | 3 | 0.6 |
| C2 | 14/24 ¹⁾ | 14/24 ¹⁾ | 14 | 14 | 3 | 0.6 |
| C3 | 10 | 10 | 10 | 10 | 3 | 0.6 |
| C4 | 14/24 ¹⁾ | 14/24 ¹⁾ | 14 | 14 | 3 | 0.6 |

Table 8.18 Terminal Tightening Torques

1) For different cable dimensions x/y, where x= \leq 95 mm² and y= \geq 95 mm².

8.8 Fuses and Circuit Breakers

Use recommended fuses and/or circuit breakers on the supply side as protection in case of component break-down inside the frequency converter (first fault).

NOTICE

Use of fuses on the supply side is mandatory for IEC 60364 (CE) and NEC 2009 (UL) compliant installations.

Recommendations:

- gG type fuses.
- Moeller type circuit breakers. For other circuit breaker types, ensure that the energy into the frequency converter is equal to or lower than the energy provided by Moeller types.

Use of recommended fuses and circuit breakers ensures that possible damage to the frequency converter is limited to damages inside the unit. For further information, see *Application Note Fuses and Circuit Breakers*.

The fuses in *chapter 8.8.1 CE Compliance* to *chapter 8.8.2 UL Compliance* are suitable for use on a circuit capable of delivering 100000 A_{rms} (symmetrical), depending on the frequency converter voltage rating. With the proper fusing, the frequency converter short-circuit current rating (SCCR) is 100000 A_{rms}.

8

8.8.1 CE Compliance

200–240 V, Enclosure sizes A, B, and C

| Enclosure | Power [kW] | Recommended fuse size | Recommended maximum fuse | Recommended circuit breaker Moeller | Maximum trip level [A] |
|-----------|------------|--|---------------------------------|-------------------------------------|------------------------|
| A2 | 0.25–2.2 | gG-10 (0.25–1.5) gG-16 (2.2) | gG-25 | PKZM0-25 | 25 |
| A3 | 3.0–3.7 | gG-16 (3) gG-20 (3.7) | gG-32 | PKZM0-25 | 25 |
| A4 | 0.25–2.2 | gG-10 (0.25–1.5) gG-16 (2.2) | gG-32 | PKZM0-25 | 25 |
| A5 | 0.25–3.7 | gG-10 (0.25–1.5) gG-16 (2.2–3) gG-20 (3.7) | gG-32 | PKZM0-25 | 25 |
| B1 | 5.5–11 | gG-25 (5.5) gG-32 (7.5) | gG-80 | PKZM4-63 | 63 |
| B2 | 15 | gG-50 | gG-100 | NZMB1-A100 | 100 |
| B3 | 5.5–11 | gG-25 | gG-63 | PKZM4-50 | 50 |
| B4 | 15–18 | gG-32 (7.5) gG-50 (11) gG-63 (15) | gG-125 | NZMB1-A100 | 100 |
| C1 | 18.5–30 | gG-63 (15) gG-80 (18.5) gG-100 (22) | gG-160 (15–18.5) aR-160 (22) | NZMB2-A200 | 160 |
| C2 | 37–45 | aR-160 (30) aR-200 (37) | aR-200 (30) aR-250 (37) | NZMB2-A250 | 250 |
| C3 | 22–30 | gG-80 (18.5) aR-125 (22) | gG-150 (18.5) aR-160 (22) | NZMB2-A200 | 150 |
| C4 | 37–45 | aR-160 (30) aR-200 (37) | aR-200 (30) aR-250 (37) | NZMB2-A250 | 250 |

Table 8.19 200–240 V, Enclosure Sizes A, B, and C

380–480 V, Enclosure Sizes A, B, and C

| Enclosure | Power [kW] | Recommended fuse size | Recommended maximum fuse | Recommended circuit breaker Moeller | Maximum trip level [A] |
|-----------|------------|--|----------------------------|-------------------------------------|------------------------|
| A2 | 1.1–4.0 | gG-10 (0.37-3) gG-16 (4) | gG-25 | PKZM0-25 | 25 |
| A3 | 5.5–7.5 | gG-16 | gG-32 | PKZM0-25 | 25 |
| A4 | 1.1–4.0 | gG-10 (0.37-3) gG-16 (4) | gG-32 | PKZM0-25 | 25 |
| A5 | 1.1–7.5 | gG-10 (0.37-3) gG-16 (4-7.5) | gG-32 | PKZM0-25 | 25 |
| B1 | 11–18.5 | gG-40 | gG-80 | PKZM4-63 | 63 |
| B2 | 22–30 | gG-50 (18.5) gG-63 (22) | gG-100 | NZMB1-A100 | 100 |
| B3 | 11–18 | gG-40 | gG-63 | PKZM4-50 | 50 |
| B4 | 22–37 | gG-50 (18.5) gG-63 (22) gG-80 (30) | gG-125 | NZMB1-A100 | 100 |
| C1 | 37–55 | gG-80 (30) gG-100 (37) gG-160 (45) | gG-160 | NZMB2-A200 | 160 |
| C2 | 75–90 | aR-200 (55) aR-250 (75) | aR-250 | NZMB2-A250 | 250 |
| C3 | 45–55 | gG-100 (37) gG-160 (45) | gG-150 (37) gG-160 (45) | NZMB2-A200 | 150 |
| C4 | 75–90 | aR-200 (55) aR-250 (75) | aR-250 | NZMB2-A250 | 250 |

Table 8.20 380–480 V, Enclosure Sizes A, B, and C

525–600 V, Enclosure Sizes A, B, and C

| Enclosure | Power [kW] | Recommended fuse size | Recommended maximum fuse | Recommended circuit breaker Moeller | Maximum trip level [A] |
|-----------|------------|--|-------------------------------|-------------------------------------|------------------------|
| A2 | 1.1–4.0 | gG-10 | gG-25 | PKZM0-25 | 25 |
| A3 | 5.5–7.5 | gG-10 (5.5) gG-16 (7.5) | gG-32 | PKZM0-25 | 25 |
| A5 | 1.1–7.5 | gG-10 (0.75-5.5) gG-16 (7.5) | gG-32 | PKZM0-25 | 25 |
| B1 | 11–18 | gG-25 (11) gG-32 (15) gG-40 (18.5) | gG-80 | PKZM4-63 | 63 |
| B2 | 22–30 | gG-50 (22) gG-63 (30) | gG-100 | NZMB1-A100 | 100 |
| B3 | 11–18.5 | gG-25 (11) gG-32 (15) | gG-63 | PKZM4-50 | 50 |
| B4 | 22–37 | gG-40 (18.5) gG-50 (22) gG-63 (30) | gG-125 | NZMB1-A100 | 100 |
| C1 | 37–55 | gG-63 (37) gG-100 (45) aR-160 (55) | gG-160 (37-45) aR-250 (55) | NZMB2-A200 | 160 |
| C2 | 75–90 | aR-200 (75) | aR-250 | NZMB2-A250 | 250 |
| C3 | 45–55 | gG-63 (37) gG-100 (45) | gG-150 | NZMB2-A200 | 150 |
| C4 | 75–90 | aR-160 (55) aR-200 (75) | aR-250 | NZMB2-A250 | 250 |

Table 8.21 525–600 V, Enclosure Sizes A, B, and C

525-690 V, Enclosure Sizes A, B, and C

| Enclosure | Power [kW] | Recommended fuse size | Recommended maximum fuse | Recommended circuit breaker Danfoss | Maximum trip level [A] |
|-----------|------------|-----------------------|--------------------------|-------------------------------------|------------------------|
| A3 | 1.1 | gG-6 | gG-25 | CTI25M 10-16 | 16 |
| | 1.5 | gG-6 | gG-25 | CTI25M 10-16 | 16 |
| | 2.2 | gG-6 | gG-25 | CTI25M 10-16 | 16 |
| | 3 | gG-10 | gG-25 | CTI25M 10-16 | 16 |
| | 4 | gG-10 | gG-25 | CTI25M 10-16 | 16 |
| | 5.5 | gG-16 | gG-25 | CTI25M 10-16 | 16 |
| | 7.5 | gG-16 | gG-25 | CTI25M 10-16 | 16 |
| B2 | 11 | gG-25 | gG-63 | | |
| | 15 | gG-25 | gG-63 | | |
| | 18 | gG-32 | | | |
| | 22 | gG-32 | | | |
| C2 | 30 | gG-40 | | | |
| | 37 | gG-63 | gG-80 | | |
| | 45 | gG-63 | gG-100 | | |
| | 55 | gG-80 | gG-125 | | |
| | 75 | gG-100 | gG-160 | | |
| C3 | 37 | gG-100 | gG-125 | | |
| | 45 | gG-125 | gG-160 | | |

Table 8.22 525–690 V, Enclosure Sizes A, B, and C

8.8.2 UL Compliance

1x200–240 V, Enclosure Sizes A, B, and C

| Recommended maximum fuse | | | | | | | | | | | | | |
|--------------------------|------------------------|----------------|--------------|------------|------------|-------------|-------------|-------------|-------------|-----------------|-------------------|--------------------|------------------|
| Power [kW] | Max. pre-fuse size [A] | Bussmann JFHR2 | Bussmann RK1 | Bussmann J | Bussmann T | Bussmann CC | Bussmann CC | Bussmann CC | SIBA RK1 | Littel fuse RK1 | Ferraz-Shawmut CC | Ferraz-Shawmut RK1 | Ferraz-Shawmut J |
| 1.1 | 15 | FWX-15 | KTN-R15 | JKS-15 | JJN-15 | FNQ-R-15 | KTK-R-15 | LP-CC-15 | 5017906-016 | KLN-R15 | ATM-R15 | A2K-15R | HSJ15 |
| 1.5 | 20 | FWX-20 | KTN-R20 | JKS-20 | JJN-20 | FNQ-R-20 | KTK-R-20 | LP-CC-20 | 5017906-020 | KLN-R20 | ATM-R20 | A2K-20R | HSJ20 |
| 2.2 | 30 ¹⁾ | FWX-30 | KTN-R30 | JKS-30 | JJN-30 | FNQ-R-30 | KTK-R-30 | LP-CC-30 | 5012406-032 | KLN-R30 | ATM-R30 | A2K-30R | HSJ30 |
| 3.0 | 35 | FWX-35 | KTN-R35 | JKS-35 | JJN-35 | – | – | – | – | KLN-R35 | – | A2K-35R | HSJ35 |
| 3.7 | 50 | FWX-50 | KTN-R50 | JKS-50 | JJN-50 | – | – | – | 5014006-050 | KLN-R50 | – | A2K-50R | HSJ50 |
| 5.5 | 60 ²⁾ | FWX-60 | KTN-R60 | JKS-60 | JJN-60 | – | – | – | 5014006-063 | KLN-R60 | – | A2K-60R | HSJ60 |
| 7.5 | 80 | FWX-80 | KTN-R80 | JKS-80 | JJN-80 | – | – | – | 5014006-080 | KLN-R80 | – | A2K-80R | HSJ80 |
| 15 | 150 | FWX-150 | KTN-R150 | JKS-150 | JJN-150 | – | – | – | 2028220-150 | KLN-R150 | – | A2K-150R | HSJ150 |
| 22 | 200 | FWX-200 | KTN-R200 | JKS-200 | JJN-200 | – | – | – | 2028220-200 | KLN-R200 | – | A2K-200R | HSJ200 |

Table 8.23 1x200–240 V, Enclosure Sizes A, B, and C

1) Siba allowed up to 32 A.

2) Siba allowed up to 63 A.

1x380–500 V, Enclosure Sizes B and C

| Recommended maximum fuse | | | | | | | | | | | | | |
|--------------------------|------------------------|----------------|--------------|------------|------------|-------------|-------------|-------------|-------------|-----------------|-------------------|--------------------|------------------|
| Power [kW] | Max. pre-fuse size [A] | Bussmann JFHR2 | Bussmann RK1 | Bussmann J | Bussmann T | Bussmann CC | Bussmann CC | Bussmann CC | SIBA RK1 | Littel fuse RK1 | Ferraz-Shawmut CC | Ferraz-Shawmut RK1 | Ferraz-Shawmut J |
| 7.5 | 60 | FWH-60 | KTS-R60 | JKS-60 | JJS-60 | – | – | – | 5014006-063 | KLS-R60 | – | A6K-60R | HSJ60 |
| 11 | 80 | FWH-80 | KTS-R80 | JKS-80 | JJS-80 | – | – | – | 2028220-100 | KLS-R80 | – | A6K-80R | HSJ80 |
| 22 | 150 | FWH-150 | KTS-R150 | JKS-150 | JJS-150 | – | – | – | 2028220-160 | KLS-R150 | – | A6K-150R | HSJ150 |
| 37 | 200 | FWH-200 | KTS-R200 | JKS-200 | JJS-200 | – | – | – | 2028220-200 | KLS-200 | – | A6K-200R | HSJ200 |

Table 8.24 1x380–500 V, Enclosure Sizes B and C

- KTS-fuses from Bussmann may substitute KTN for 240 V frequency converters.
- FWH-fuses from Bussmann may substitute FWX for 240 V frequency converters.
- JJS-fuses from Bussmann may substitute JJN for 240 V frequency converters.
- KLSR fuses from Littel fuse may substitute KLN-R fuses for 240 V frequency converters.
- A6KR fuses from Ferraz-Shawmut may substitute A2KR for 240 V frequency converters.

3x200–240 V, Enclosure Sizes A, B, and C

| Power [kW] | Recommended maximum fuse | | | | | |
|------------|---------------------------------|-----------------|-----------------|------------------|----------|------------------|
| | Bussmann Type RK1 ¹⁾ | Bussmann Type J | Bussmann Type T | Bussmann Type CC | Bussmann | Bussmann Type CC |
| 0.25–0.37 | KTN-R-05 | JKS-05 | JJN-05 | FNQ-R-5 | KTK-R-5 | LP-CC-5 |
| 0.55–1.1 | KTN-R-10 | JKS-10 | JJN-10 | FNQ-R-10 | KTK-R-10 | LP-CC-10 |
| 1.5 | KTN-R-15 | JKS-15 | JJN-15 | FNQ-R-15 | KTK-R-15 | LP-CC-15 |
| 2.2 | KTN-R-20 | JKS-20 | JJN-20 | FNQ-R-20 | KTK-R-20 | LP-CC-20 |
| 3.0 | KTN-R-25 | JKS-25 | JJN-25 | FNQ-R-25 | KTK-R-25 | LP-CC-25 |
| 3.7 | KTN-R-30 | JKS-30 | JJN-30 | FNQ-R-30 | KTK-R-30 | LP-CC-30 |
| 5.5–7.5 | KTN-R-50 | JKS-50 | JJN-50 | – | – | – |
| 11 | KTN-R-60 | JKS-60 | JJN-60 | – | – | – |
| 15 | KTN-R-80 | JKS-80 | JJN-80 | – | – | – |
| 18.5–22 | KTN-R-125 | JKS-125 | JJN-125 | – | – | – |
| 30 | KTN-R-150 | JKS-150 | JJN-150 | – | – | – |
| 37 | KTN-R-200 | JKS-200 | JJN-200 | – | – | – |
| 45 | KTN-R-250 | JKS-250 | JJN-250 | – | – | – |

Table 8.25 3x200–240 V, Enclosure Sizes A, B, and C

8

| Power [kW] | Recommended maximum fuse | | | | | | | |
|------------|--------------------------|----------------------|------------------------|---------------------------------------|-----------------------------------|-------------------|------------------------------------|------------------|
| | SIBA Type RK1 | Littel fuse Type RK1 | Ferraz-Shawmut Type CC | Ferraz-Shawmut Type RK1 ²⁾ | Bussmann Type JFHR2 ³⁾ | Littel fuse JFHR2 | Ferraz-Shawmut JFHR2 ⁴⁾ | Ferraz-Shawmut J |
| 0.25–0.37 | 5017906-005 | KLN-R-05 | ATM-R-05 | A2K-05-R | FWX-5 | – | – | HSJ-6 |
| 0.55–1.1 | 5017906-010 | KLN-R-10 | ATM-R-10 | A2K-10-R | FWX-10 | – | – | HSJ-10 |
| 1.5 | 5017906-016 | KLN-R-15 | ATM-R-15 | A2K-15-R | FWX-15 | – | – | HSJ-15 |
| 2.2 | 5017906-020 | KLN-R-20 | ATM-R-20 | A2K-20-R | FWX-20 | – | – | HSJ-20 |
| 3.0 | 5017906-025 | KLN-R-25 | ATM-R-25 | A2K-25-R | FWX-25 | – | – | HSJ-25 |
| 3.7 | 5012406-032 | KLN-R-30 | ATM-R-30 | A2K-30-R | FWX-30 | – | – | HSJ-30 |
| 5.5–7.5 | 5014006-050 | KLN-R-50 | – | A2K-50-R | FWX-50 | – | – | HSJ-50 |
| 11 | 5014006-063 | KLN-R-60 | – | A2K-60-R | FWX-60 | – | – | HSJ-60 |
| 15 | 5014006-080 | KLN-R-80 | – | A2K-80-R | FWX-80 | – | – | HSJ-80 |
| 18.5–22 | 2028220-125 | KLN-R-125 | – | A2K-125-R | FWX-125 | – | – | HSJ-125 |
| 30 | 2028220-150 | KLN-R-150 | – | A2K-150-R | FWX-150 | L25S-150 | A25X-150 | HSJ-150 |
| 37 | 2028220-200 | KLN-R-200 | – | A2K-200-R | FWX-200 | L25S-200 | A25X-200 | HSJ-200 |
| 45 | 2028220-250 | KLN-R-250 | – | A2K-250-R | FWX-250 | L25S-250 | A25X-250 | HSJ-250 |

Table 8.26 3x200–240 V, Enclosure Sizes A, B, and C

- 1) KTS-fuses from Bussmann may substitute KTN for 240 V frequency converters.
- 2) A6KR fuses from Ferraz-Shawmut may substitute A2KR for 240 V frequency converters.
- 3) FWH-fuses from Bussmann may substitute FWX for 240 V frequency converters.
- 4) A50X fuses from Ferraz-Shawmut may substitute A25X for 240 V frequency converters.

3x380–480 V, Enclosure Sizes A, B, and C

| Power [kW] | Recommended maximum fuse | | | | | |
|------------|--------------------------|-----------------|-----------------|------------------|------------------|------------------|
| | Bussmann Type RK1 | Bussmann Type J | Bussmann Type T | Bussmann Type CC | Bussmann Type CC | Bussmann Type CC |
| - | KTS-R-6 | JKS-6 | JJS-6 | FNQ-R-6 | KTK-R-6 | LP-CC-6 |
| 1.1–2.2 | KTS-R-10 | JKS-10 | JJS-10 | FNQ-R-10 | KTK-R-10 | LP-CC-10 |
| 3 | KTS-R-15 | JKS-15 | JJS-15 | FNQ-R-15 | KTK-R-15 | LP-CC-15 |
| 4 | KTS-R-20 | JKS-20 | JJS-20 | FNQ-R-20 | KTK-R-20 | LP-CC-20 |
| 5.5 | KTS-R-25 | JKS-25 | JJS-25 | FNQ-R-25 | KTK-R-25 | LP-CC-25 |
| 7.5 | KTS-R-30 | JKS-30 | JJS-30 | FNQ-R-30 | KTK-R-30 | LP-CC-30 |
| 11 | KTS-R-40 | JKS-40 | JJS-40 | - | - | - |
| 15 | KTS-R-50 | JKS-50 | JJS-50 | - | - | - |
| 22 | KTS-R-60 | JKS-60 | JJS-60 | - | - | - |
| 30 | KTS-R-80 | JKS-80 | JJS-80 | - | - | - |
| 37 | KTS-R-100 | JKS-100 | JJS-100 | - | - | - |
| 45 | KTS-R-125 | JKS-125 | JJS-125 | - | - | - |
| 55 | KTS-R-150 | JKS-150 | JJS-150 | - | - | - |
| 75 | KTS-R-200 | JKS-200 | JJS-200 | - | - | - |
| 90 | KTS-R-250 | JKS-250 | JJS-250 | - | - | - |

Table 8.27 3x380–480 V, Enclosure Sizes A, B, and C

8

| Power [kW] | Recommended maximum fuse | | | | | | | |
|------------|--------------------------|----------------------|------------------------|-------------------------|----------------|------------------|------------------------------------|-------------------|
| | SIBA Type RK1 | Littel fuse Type RK1 | Ferraz-Shawmut Type CC | Ferraz-Shawmut Type RK1 | Bussmann JFHR2 | Ferraz-Shawmut J | Ferraz-Shawmut JFHR2 ¹⁾ | Littel fuse JFHR2 |
| - | 5017906-006 | KLS-R-6 | ATM-R-6 | A6K-6-R | FWH-6 | HSJ-6 | - | - |
| 1.1–2.2 | 5017906-010 | KLS-R-10 | ATM-R-10 | A6K-10-R | FWH-10 | HSJ-10 | - | - |
| 3 | 5017906-016 | KLS-R-15 | ATM-R-15 | A6K-15-R | FWH-15 | HSJ-15 | - | - |
| 4 | 5017906-020 | KLS-R-20 | ATM-R-20 | A6K-20-R | FWH-20 | HSJ-20 | - | - |
| 5.5 | 5017906-025 | KLS-R-25 | ATM-R-25 | A6K-25-R | FWH-25 | HSJ-25 | - | - |
| 7.5 | 5012406-032 | KLS-R-30 | ATM-R-30 | A6K-30-R | FWH-30 | HSJ-30 | - | - |
| 11 | 5014006-040 | KLS-R-40 | - | A6K-40-R | FWH-40 | HSJ-40 | - | - |
| 15 | 5014006-050 | KLS-R-50 | - | A6K-50-R | FWH-50 | HSJ-50 | - | - |
| 22 | 5014006-063 | KLS-R-60 | - | A6K-60-R | FWH-60 | HSJ-60 | - | - |
| 30 | 2028220-100 | KLS-R-80 | - | A6K-80-R | FWH-80 | HSJ-80 | - | - |
| 37 | 2028220-125 | KLS-R-100 | - | A6K-100-R | FWH-100 | HSJ-100 | - | - |
| 45 | 2028220-125 | KLS-R-125 | - | A6K-125-R | FWH-125 | HSJ-125 | - | - |
| 55 | 2028220-160 | KLS-R-150 | - | A6K-150-R | FWH-150 | HSJ-150 | - | - |
| 75 | 2028220-200 | KLS-R-200 | - | A6K-200-R | FWH-200 | HSJ-200 | A50-P-225 | L50-S-225 |
| 90 | 2028220-250 | KLS-R-250 | - | A6K-250-R | FWH-250 | HSJ-250 | A50-P-250 | L50-S-250 |

Table 8.28 3x380–480 V, Enclosure Sizes A, B, and C

1) Ferraz-Shawmut A50QS fuses may substitute A50P fuses.

3x525–600 V, Enclosure Sizes A, B, and C

| Power [kW] | Recommended maximum fuse | | | | | | | | | |
|------------|--------------------------|------------------|-----------------|------------------|-------------------|-------------------|---------------|----------------------|-------------------------|------------------|
| | Bussmann Type RK1 | Bussman n Type J | Bussmann Type T | Bussmann Type CC | Bussman n Type CC | Bussman n Type CC | SIBA Type RK1 | Littel fuse Type RK1 | Ferraz-Shawmut Type RK1 | Ferraz-Shawmut J |
| 0.75–1.1 | KTS-R-5 | JKS-5 | JJS-6 | FNQ-R-5 | KTK-R-5 | LP-CC-5 | 5017906-005 | KLS-R-005 | A6K-5-R | HSJ-6 |
| 1.5–2.2 | KTS-R-10 | JKS-10 | JJS-10 | FNQ-R-10 | KTK-R-10 | LP-CC-10 | 5017906-010 | KLS-R-010 | A6K-10-R | HSJ-10 |
| 3 | KTS-R15 | JKS-15 | JJS-15 | FNQ-R-15 | KTK-R-15 | LP-CC-15 | 5017906-016 | KLS-R-015 | A6K-15-R | HSJ-15 |
| 4 | KTS-R20 | JKS-20 | JJS-20 | FNQ-R-20 | KTK-R-20 | LP-CC-20 | 5017906-020 | KLS-R-020 | A6K-20-R | HSJ-20 |
| 5.5 | KTS-R-25 | JKS-25 | JJS-25 | FNQ-R-25 | KTK-R-25 | LP-CC-25 | 5017906-025 | KLS-R-025 | A6K-25-R | HSJ-25 |
| 7.5 | KTS-R-30 | JKS-30 | JJS-30 | FNQ-R-30 | KTK-R-30 | LP-CC-30 | 5017906-030 | KLS-R-030 | A6K-30-R | HSJ-30 |
| 11–15 | KTS-R-35 | JKS-35 | JJS-35 | – | – | – | 5014006-040 | KLS-R-035 | A6K-35-R | HSJ-35 |
| 18 | KTS-R-45 | JKS-45 | JJS-45 | – | – | – | 5014006-050 | KLS-R-045 | A6K-45-R | HSJ-45 |
| 22 | KTS-R-50 | JKS-50 | JJS-50 | – | – | – | 5014006-050 | KLS-R-050 | A6K-50-R | HSJ-50 |
| 30 | KTS-R-60 | JKS-60 | JJS-60 | – | – | – | 5014006-063 | KLS-R-060 | A6K-60-R | HSJ-60 |
| 37 | KTS-R-80 | JKS-80 | JJS-80 | – | – | – | 5014006-080 | KLS-R-075 | A6K-80-R | HSJ-80 |
| 45 | KTS-R-100 | JKS-100 | JJS-100 | – | – | – | 5014006-100 | KLS-R-100 | A6K-100-R | HSJ-100 |
| 55 | KTS-R-125 | JKS-125 | JJS-125 | – | – | – | 2028220-125 | KLS-R-125 | A6K-125-R | HSJ-125 |
| 75 | KTS-R-150 | JKS-150 | JJS-150 | – | – | – | 2028220-150 | KLS-R-150 | A6K-150-R | HSJ-150 |
| 90 | KTS-R-175 | JKS-175 | JJS-175 | – | – | – | 2028220-200 | KLS-R-175 | A6K-175-R | HSJ-175 |

Table 8.29 3x525–600 V, Enclosure Sizes A, B, and C

3x525–690 V, Enclosure Sizes B and C

| Power [kW] | Maximum pre-fuse [A] | Recommended maximum fuse | | | | | | |
|------------|----------------------|--------------------------|-----------------------|-----------------------|-----------------------|----------------------------|---------------------------------------|----------------------------|
| | | Bussmann E52273 RK1/JDDZ | Bussmann E4273 J/JDDZ | Bussmann E4273 T/JDDZ | SIBA E180276 RK1/JDDZ | LittelFuse E81895 RK1/JDDZ | Ferraz-Shawmut E163267/E2137 RK1/JDDZ | Ferraz-Shawmut E2137 J/HSJ |
| 11–15 | 30 | KTS-R-30 | JKS-30 | JJS-30 | 5017906-030 | KLS-R-030 | A6K-30-R | HST-30 |
| 22 | 45 | KTS-R-45 | JKS-45 | JJS-45 | 5014006-050 | KLS-R-045 | A6K-45-R | HST-45 |
| 30 | 60 | KTS-R-60 | JKS-60 | JJS-60 | 5014006-063 | KLS-R-060 | A6K-60-R | HST-60 |
| 37 | 80 | KTS-R-80 | JKS-80 | JJS-80 | 5014006-080 | KLS-R-075 | A6K-80-R | HST-80 |
| 45 | 90 | KTS-R-90 | JKS-90 | JJS-90 | 5014006-100 | KLS-R-090 | A6K-90-R | HST-90 |
| 55 | 100 | KTS-R-100 | JKS-100 | JJS-100 | 5014006-100 | KLS-R-100 | A6K-100-R | HST-100 |
| 75 | 125 | KTS-R-125 | JKS-125 | JJS-125 | 2028220-125 | KLS-150 | A6K-125-R | HST-125 |
| 90 | 150 | KTS-R-150 | JKS-150 | JJS-150 | 2028220-150 | KLS-175 | A6K-150-R | HST-150 |

Table 8.30 3x525–690 V, Enclosure Sizes B and C

8.9 Power Ratings, Weight, and Dimensions

| Enclosure size [kW] | | A2 | | A3 | | A4 | A5 |
|---|-----------------|----------|--------|----------|--------|------------|------------|
| 3x525-690 V | T7 | - | | - | | - | - |
| 3x525-600 V | T6 | - | | 0.75-7.5 | | - | 0.75-7.5 |
| 3x380-480 V | T4 | 0.37-4.0 | | 5.5-7.5 | | 0.37-4.0 | 0.37-7.5 |
| 1x380-480 V | S4 | - | | - | | 1.1-4.0 | - |
| 3x200-240 V | T2 | 0.25-3.0 | | 3.7 | | 0.25-2.2 | 0.25-3.7 |
| 1x200-240 V | S2 | - | | 1.1 | | 1.1-2.2 | 1.1 |
| IP | | 20 | 21 | 20 | 21 | 55/66 | 55/66 |
| NEMA | | Chassis | Type 1 | Chassis | Type 1 | Type 12/4X | Type 12/4X |
| Height [mm] | | | | | | | |
| Height of back plate | A ¹⁾ | 268 | 375 | 268 | 375 | 390 | 420 |
| Height with de-coupling plate for fieldbus cables | A | 374 | - | 374 | - | - | - |
| Distance between mounting holes | a | 257 | 350 | 257 | 350 | 401 | 402 |
| Width [mm] | | | | | | | |
| Width of back plate | B | 90 | 90 | 130 | 130 | 200 | 242 |
| Width of back plate with 1 C option | B | 130 | 130 | 170 | 170 | - | 242 |
| Width of back plate with 2 C options | B | 90 | 90 | 130 | 130 | - | 242 |
| Distance between mounting holes | b | 70 | 70 | 110 | 110 | 171 | 215 |
| Depth²⁾ [mm] | | | | | | | |
| Without option A/B | C | 205 | 205 | 205 | 205 | 175 | 200 |
| With option A/B | C | 220 | 220 | 220 | 220 | 175 | 200 |
| Screw holes [mm] | | | | | | | |
| | c | 8.0 | 8.0 | 8.0 | 8.0 | 8.25 | 8.2 |
| | d | ø11 | ø11 | ø11 | ø11 | ø12 | ø12 |
| | e | ø5.5 | ø5.5 | ø5.5 | ø5.5 | ø6.5 | ø6.5 |
| | f | 9 | 9 | 9 | 9 | 6 | 9 |
| Maximum weight [kg] | | 4.9 | 5.3 | 6.6 | 7.0 | 9.7 | 14 |
| 1) See <i>Illustration 3.4</i> and <i>Illustration 3.5</i> for top and bottom mounting holes. | | | | | | | |
| 2) Depth of enclosure will vary with different options installed. | | | | | | | |



Table 8.31 Power Ratings, Weight, and Dimensions, Enclosure Sizes A2-A5

| Enclosure size [kW] | | B1 | B2 | B3 | B4 | C1 | C2 | C3 | C4 |
|---|-----------------|--------------|--------------|---------|---------|--------------|--------------|---------|---------|
| 3x525-690 V | T7 | – | 11–30 | – | – | – | 37–90 | – | – |
| 3x525-600 V | T6 | 11–18.5 | 22–30 | 11–18.5 | 22–37 | 37–55 | 75–90 | 45–55 | 75–90 |
| 3x380-480 V | T4 | 11–18.5 | 22–30 | 11–18.5 | 22–37 | 37–55 | 75–90 | 45–55 | 75–90 |
| 1x380-480 V | S4 | 7.5 | 11 | – | – | 18 | 37 | – | – |
| 3x200-240 V | T2 | 5.5–11 | 15 | 5.5–11 | 15–18.5 | 18.5–30 | 37–45 | 22–30 | 37–45 |
| 1x200-240 V | S2 | 1.5–3.7 | 7.5 | – | – | 15 | 22 | – | – |
| IP | | 21/55/66 | 21/55/66 | 20 | 20 | 21/55/66 | 21/55/66 | 20 | 20 |
| NEMA | | Type 1/12/4X | Type 1/12/4X | Chassis | Chassis | Type 1/12/4X | Type 1/12/4X | Chassis | Chassis |
| Height [mm] | | | | | | | | | |
| Height of back plate | A ¹⁾ | 480 | 650 | 399 | 520 | 680 | 770 | 550 | 660 |
| Height with de-coupling plate for fieldbus cables | A | – | – | 419 | 595 | – | – | 630 | 800 |
| Distance between mounting holes | a | 454 | 624 | 380 | 495 | 648 | 739 | 521 | 631 |
| Width [mm] | | | | | | | | | |
| Width of back plate | B | 242 | 242 | 165 | 231 | 308 | 370 | 308 | 370 |
| Width of back plate with 1 C option | B | 242 | 242 | 205 | 231 | 308 | 370 | 308 | 370 |
| Width of back plate with 2 C options | B | 242 | 242 | 165 | 231 | 308 | 370 | 308 | 370 |
| Distance between mounting holes | b | 210 | 210 | 140 | 200 | 272 | 334 | 270 | 330 |
| Depth²⁾ [mm] | | | | | | | | | |
| Without option A/B | C | 260 | 260 | 248 | 242 | 310 | 335 | 333 | 333 |
| With option A/B | C | 260 | 260 | 262 | 242 | 310 | 335 | 333 | 333 |
| Screw holes [mm] | | | | | | | | | |
| | c | 12 | 12 | 8 | – | 12 | 12 | – | – |
| | d | ø19 | ø19 | 12 | – | ø19 | ø19 | – | – |
| | e | ø9 | ø9 | 6.8 | 8.5 | ø9.0 | ø9.0 | 8.5 | 8.5 |
| | f | 9 | 9 | 7.9 | 15 | 9.8 | 9.8 | 17 | 17 |
| Maximum weight [kg] | | 23 | 27 | 12 | 23.5 | 45 | 65 | 35 | 50 |
| 1) See <i>Illustration 3.4</i> and <i>Illustration 3.5</i> for top and bottom mounting holes. | | | | | | | | | |
| 2) Depth of enclosure will vary with different options installed. | | | | | | | | | |

Table 8.32 Power Ratings, Weight, and Dimensions, Enclosure Sizes B1-B4, C1-C4

9 Appendix

9.1 Symbols, Abbreviations, and Conventions

| | |
|---------------|--|
| °C | Degrees celsius |
| AC | Alternating current |
| AEO | Automatic energy optimization |
| AWG | American wire gauge |
| AMA | Automatic motor adaptation |
| DC | Direct current |
| EMC | Electro magnetic compatibility |
| ETR | Electronic thermal relay |
| $f_{M,N}$ | Nominal motor frequency |
| FC | Frequency converter |
| I_{INV} | Rated inverter output current |
| I_{LIM} | Current limit |
| $I_{M,N}$ | Nominal motor current |
| $I_{VLT,MAX}$ | Maximum output current |
| $I_{VLT,N}$ | Rated output current supplied by the frequency converter |
| IP | Ingress protection |
| LCP | Local control panel |
| MCT | Motion control tool |
| n_s | Synchronous motor speed |
| $P_{M,N}$ | Nominal motor power |
| PELV | Protective extra low voltage |
| PCB | Printed circuit board |
| PM Motor | Permanent magnet motor |
| PWM | Pulse width modulation |
| RPM | Revolutions per minute |
| Regen | Regenerative terminals |
| T_{LIM} | Torque limit |
| $U_{M,N}$ | Nominal motor voltage |

Table 9.1 Symbols and Abbreviations

Conventions

Numbered lists indicate procedures.

Bullet lists indicate other information.

Italicised text indicates:

- Cross reference.
- Link.
- Parameter name.

All dimensions are in [mm].

9.2 Parameter Menu Structure

| | | | | | | |
|------|--------------------------------------|---|---------------------------------------|------------------------------------|---|---|
| 0-0* | Operation / Display | 1-03 Torque Characteristics | 1-86 Trip Speed Low [RPM] | 4-1* | Motor Limits | 5-50 Term. 29 Low Frequency |
| 0-0* | Basic Settings | 1-04 Overload Mode | 1-87 Trip Speed Low [Hz] | 4-10 Motor Speed Direction | 5-51 Term. 29 High Frequency | 5-51 Term. 29 High Frequency |
| 0-01 | Language | 1-06 Clockwise Direction | 1-9* Motor Temperature | 4-11 Motor Speed Low Limit [RPM] | 5-52 Term. 29 Low Ref./Feedb. Value | 5-52 Term. 29 Low Ref./Feedb. Value |
| 0-02 | Motor Speed Unit | 1-1* Motor Selection | 1-90 Motor Thermal Protection | 4-12 Motor Speed Low Limit [Hz] | 5-53 Term. 29 High Ref./Feedb. Value | 5-53 Term. 29 High Ref./Feedb. Value |
| 0-03 | Regional Settings | 1-10 Motor Construction | 1-91 Motor External Fan | 4-13 Motor Speed High Limit [RPM] | 5-54 Pulse Filter Time Constant #29 | 5-54 Pulse Filter Time Constant #29 |
| 0-04 | Operating State at Power-up | 1-1* WVC+ PM | 1-93 Thermistor Source | 4-14 Motor Speed High Limit [Hz] | 5-55 Term. 33 Low Frequency | 5-55 Term. 33 Low Frequency |
| 0-05 | Local Mode Unit | 1-14 Damping Gain | 2-** Brakes | 4-16 Torque Limit Motor Mode | 5-56 Term. 33 High Frequency | 5-56 Term. 33 High Frequency |
| 0-1* | Set-up Operations | 1-15 Low Speed Filter Time Const. | 2-0* DC Brake | 4-17 Torque Limit Generator Mode | 5-57 Term. 33 Low Ref./Feedb. Value | 5-57 Term. 33 Low Ref./Feedb. Value |
| 0-10 | Active Set-up | 1-16 High Speed Filter Time Const. | 2-00 DC Hold/Preheat Current | 4-18 Current Limit | 5-58 Term. 33 High Ref./Feedb. Value | 5-58 Term. 33 High Ref./Feedb. Value |
| 0-11 | Programming Set-up | 1-17 Voltage filter time const. | 2-01 DC Brake Current | 4-19 Max Output Frequency | 5-59 Pulse Filter Time Constant #33 | 5-59 Pulse Filter Time Constant #33 |
| 0-12 | This Set-up Linked to | 1-2* Motor Data | 2-02 DC Braking Time | 4-5* Adj. Warnings | 5-6* Pulse Output | 5-6* Pulse Output |
| 0-13 | Readout: Linked Set-ups | 1-20 Motor Power [kW] | 2-03 DC Brake Cut In Speed [RPM] | 4-50 Warning Current Low | 5-60 Terminal 27 Pulse Output Variable | 5-60 Terminal 27 Pulse Output Variable |
| 0-14 | Readout: Prog. Set-ups / Channel | 1-21 Motor Power [HP] | 2-04 DC Brake Cut In Speed [Hz] | 4-51 Warning Current High | 5-62 Pulse Output Max Freq #27 | 5-62 Pulse Output Max Freq #27 |
| 0-2* | LCP Display | 1-22 Motor Voltage | 2-06 Parking Current | 4-52 Warning Speed Low | 5-63 Terminal 29 Pulse Output Variable | 5-63 Terminal 29 Pulse Output Variable |
| 0-20 | Display Line 1.1 Small | 1-23 Motor Frequency | 2-07 Parking Time | 4-53 Warning Speed High | 5-65 Pulse Output Max Freq #29 | 5-65 Pulse Output Max Freq #29 |
| 0-21 | Display Line 1.2 Small | 1-24 Motor Current | 2-1* Brake Energy Funct. | 4-54 Warning Reference Low | 5-66 Terminal X30/6 Pulse Output Variable | 5-66 Terminal X30/6 Pulse Output Variable |
| 0-22 | Display Line 1.3 Small | 1-25 Motor Nominal Speed | 2-10 Brake Function | 4-55 Warning Reference High | 5-68 Pulse Output Max Freq #X30/6 | 5-68 Pulse Output Max Freq #X30/6 |
| 0-23 | Display Line 2 Large | 1-26 Motor Cont. Rated Torque | 2-11 Brake Resistor (ohm) | 4-56 Warning Feedback Low | 5-8* I/O Options | 5-8* I/O Options |
| 0-24 | Display Line 3 Large | 1-28 Motor Rotation Check | 2-12 Brake Power Limit (kW) | 4-57 Warning Feedback High | 5-80 AHF Cap Reconnect Delay | 5-80 AHF Cap Reconnect Delay |
| 0-25 | My Personal Menu | 1-29 Automatic Motor Adaptation (AMA) | 2-13 Brake Power Monitoring | 4-58 Missing Motor Phase Function | 5-9* Bus Controlled | 5-9* Bus Controlled |
| 0-3* | LCP Custom Readout | 1-3* Adv. Motor Data | 2-15 Brake Check | 4-6* Speed Bypass | 5-90 Digital & Relay Bus Control | 5-90 Digital & Relay Bus Control |
| 0-30 | Custom Readout Unit | 1-30 Stator Resistance (Rs) | 2-16 AC brake Max. Current | 4-60 Bypass Speed From [RPM] | 5-93 Pulse Out #27 Bus Control | 5-93 Pulse Out #27 Bus Control |
| 0-31 | Custom Readout Min Value | 1-31 Rotor Resistance (Rr) | 2-17 Over-voltage Control | 4-61 Bypass Speed From [Hz] | 5-94 Pulse Out #27 Timeout Preset | 5-94 Pulse Out #27 Timeout Preset |
| 0-32 | Custom Readout Max Value | 1-33 Stator Leakage Reactance (X1) | 3-** Reference / Ramps | 4-62 Bypass Speed To [RPM] | 5-95 Pulse Out #29 Bus Control | 5-95 Pulse Out #29 Bus Control |
| 0-37 | Display Text 1 | 1-34 Rotor Leakage Reactance (X2) | 3-0* Reference Limits | 4-63 Bypass Speed To [Hz] | 5-96 Pulse Out #30 Timeout Preset | 5-96 Pulse Out #30 Timeout Preset |
| 0-38 | Display Text 2 | 1-35 Main Reactance (Xh) | 3-02 Minimum Reference | 4-64 Semi-Auto Bypass Set-up | 5-97 Pulse Out #X30/6 Bus Control | 5-97 Pulse Out #X30/6 Bus Control |
| 0-39 | Display Text 3 | 1-36 Iron Loss Resistance (Rfe) | 3-03 Maximum Reference | 5-** Digital In/Out | 5-98 Pulse Out #X30/6 Timeout Preset | 5-98 Pulse Out #X30/6 Timeout Preset |
| 0-4* | LCP keypad | 1-37 d-axis Inductance (Ld) | 3-04 Reference Function | 5-0* Digital I/O mode | 6-0* Analog In/Out | 6-0* Analog In/Out |
| 0-40 | [Hand on] Key on LCP | 1-39 Motor Poles | 3-1* References | 5-00 Digital I/O Mode | 6-00 Live Zero Timeout Time | 6-00 Live Zero Timeout Time |
| 0-41 | [Off] Key on LCP | 1-40 Back EMF at 1000 RPM | 3-10 Preset Reference | 5-01 Terminal 27 Mode | 6-01 Live Zero Timeout Function | 6-01 Live Zero Timeout Function |
| 0-42 | [Auto on] Key on LCP | 1-46 Position Detection Gain | 3-11 Jog Speed [Hz] | 5-02 Terminal 29 Mode | 6-1* Analog Input 53 | 6-1* Analog Input 53 |
| 0-43 | [Reset] Key on LCP | 1-5* Load Indep. Setting | 3-13 Reference Site | 5-1* Digital Inputs | 6-10 Terminal 53 Low Voltage | 6-10 Terminal 53 Low Voltage |
| 0-44 | [Off/Reset] Key on LCP | 1-50 Motor Magnetisation at Zero Speed | 3-14 Preset Relative Reference | 5-10 Terminal 18 Digital Input | 6-11 Terminal 53 High Voltage | 6-11 Terminal 53 High Voltage |
| 0-45 | [Drive Bypass] Key on LCP | 1-51 Min Speed Normal Magnetising [RPM] | 3-15 Reference 1 Source | 5-11 Terminal 19 Digital Input | 6-12 Terminal 53 Low Current | 6-12 Terminal 53 Low Current |
| 0-5* | Copy/Save | 1-52 Min Speed Normal Magnetising [Hz] | 3-16 Reference 2 Source | 5-12 Terminal 27 Digital Input | 6-13 Terminal 53 High Current | 6-13 Terminal 53 High Current |
| 0-50 | LCP Copy | 1-56 V/f Characteristic - V | 3-17 Reference 3 Source | 5-13 Terminal 29 Digital Input | 6-14 Terminal 53 Low Ref./Feedb. Value | 6-14 Terminal 53 Low Ref./Feedb. Value |
| 0-51 | Set-up Copy | 1-56 V/f Characteristic - f | 3-19 Jog Speed [RPM] | 5-14 Terminal 32 Digital Input | 6-15 Terminal 53 High Ref./Feedb. Value | 6-15 Terminal 53 High Ref./Feedb. Value |
| 0-6* | Password | 1-58 Flying Start Test Pulses Current | 3-4* Ramp 1 | 5-15 Terminal 33 Digital Input | 6-16 Terminal 53 Filter Time Constant | 6-16 Terminal 53 Filter Time Constant |
| 0-60 | Main Menu Password | 1-59 Flying Start Test Pulses Frequency | 3-41 Ramp 1 Ramp Up Time | 5-16 Terminal X30/2 Digital Input | 6-17 Terminal 53 Live Zero | 6-17 Terminal 53 Live Zero |
| 0-61 | Access to Main Menu w/o Password | 1-6* Load Depen. Setting | 3-42 Ramp 1 Ramp Down Time | 5-17 Terminal X30/3 Digital Input | 6-2* Analog Input 54 | 6-2* Analog Input 54 |
| 0-65 | Personal Menu Password | 1-60 Low Speed Load Compensation | 3-5* Ramp 2 | 5-18 Terminal X30/4 Digital Input | 6-20 Terminal 54 Low Voltage | 6-20 Terminal 54 Low Voltage |
| 0-66 | Access to Personal Menu w/o Password | 1-61 High Speed Load Compensation | 3-52 Ramp 2 Ramp Up Time | 5-19 Terminal X46/1 Digital Input | 6-21 Terminal 54 High Voltage | 6-21 Terminal 54 High Voltage |
| 0-67 | Bus Password Access | 1-62 Slip Compensation | 3-58 Other Ramps | 5-20 Terminal X46/3 Digital Input | 6-22 Terminal 54 Low Current | 6-22 Terminal 54 Low Current |
| 0-7* | Clock Settings | 1-63 Slip Compensation Time Constant | 3-80 Jog Ramp Time | 5-21 Terminal X46/5 Digital Input | 6-23 Terminal 54 High Current | 6-23 Terminal 54 High Current |
| 0-70 | Date and Time | 1-64 Resonance Damping | 3-81 Quick Stop Ramp Time | 5-22 Terminal X46/7 Digital Input | 6-24 Terminal 54 Low Ref./Feedb. Value | 6-24 Terminal 54 Low Ref./Feedb. Value |
| 0-71 | Date Format | 1-65 Resonance Damping Time Constant | 3-84 Initial Ramp Time | 5-23 Terminal X46/9 Digital Input | 6-25 Terminal 54 High Ref./Feedb. Value | 6-25 Terminal 54 High Ref./Feedb. Value |
| 0-72 | Time Format | 1-66 Min. Current at Low Speed | 3-85 Check Valve Ramp Time | 5-25 Terminal X46/13 Digital Input | 6-26 Terminal 54 Filter Time Constant | 6-26 Terminal 54 Filter Time Constant |
| 0-74 | DST/Summertime | 1-7* Start Adjustments | 3-86 Check Valve Ramp End Speed [RPM] | 5-26 Terminal X46/13 Digital Input | 6-27 Terminal 54 Live Zero | 6-27 Terminal 54 Live Zero |
| 0-76 | DST/Summertime Start | 1-70 PM Start Mode | 3-87 Check Valve Ramp End Speed [Hz] | 5-3* Digital Outputs | 6-3* Analog Input X30/11 | 6-3* Analog Input X30/11 |
| 0-77 | DST/Summertime End | 1-71 Start Delay | 3-88 Final Ramp Time | 5-30 Terminal 27 Digital Output | 6-30 Terminal X30/11 Low Voltage | 6-30 Terminal X30/11 Low Voltage |
| 0-79 | Clock Fault | 1-72 Start Function | 3-9* Digital Pot.Meter | 5-31 Terminal 29 Digital Output | 6-31 Terminal X30/11 High Voltage | 6-31 Terminal X30/11 High Voltage |
| 0-81 | Working Days | 1-73 Flying Start | 3-90 Step Size | 5-32 Term X30/6 Digi Out (MCB 101) | 6-34 Term. X30/11 Low Ref./Feedb. Value | 6-34 Term. X30/11 Low Ref./Feedb. Value |
| 0-82 | Additional Working Days | 1-77 Compressor Start Max Speed [RPM] | 3-92 Power Restore | 5-33 Term X30/7 Digi Out (MCB 101) | 6-35 Term. X30/11 High Ref./Feedb. Value | 6-35 Term. X30/11 High Ref./Feedb. Value |
| 0-83 | Additional Non-Working Days | 1-78 Compressor Start Max Speed [Hz] | 3-93 Maximum Limit | 5-4* Relays | 6-36 Term. X30/11 Filter Time Constant | 6-36 Term. X30/11 Filter Time Constant |
| 0-89 | Date and Time Readout | 1-79 Pump Start Max Time to Trip | 3-94 Minimum Limit | 5-40 Function Relay | 6-37 Term. X30/11 Live Zero | 6-37 Term. X30/11 Live Zero |
| 1-0* | Load and Motor | 1-8* Stop Adjustments | 3-95 Ramp Delay | 5-41 On Delay, Relay | 6-4* Analog Input X30/12 | 6-4* Analog Input X30/12 |
| 1-0* | General Settings | 1-80 Function at Stop | 4-** Limits / Warnings | 5-42 Off Delay, Relay | 6-40 Terminal X30/12 Low Voltage | 6-40 Terminal X30/12 Low Voltage |
| 1-00 | Configuration Mode | 1-81 Min Speed for Function at Stop [RPM] | | 5-43 Pulse Input | 6-41 Terminal X30/12 High Voltage | 6-41 Terminal X30/12 High Voltage |
| 1-01 | Motor Control Principle | 1-82 Min Speed for Function at Stop [Hz] | | | | |

| | | | | | | | | | |
|------|--------------------------------------|-------|---------------------------|-------|--------------------------------|-------|----------------------------------|-------|-------------------------------------|
| 6-44 | Term. X30/12 Low Ref./Feedb. Value | 8-54 | Reversing Select | 10-00 | CAN Protocol | 12-4* | Modbus TCP | 14-20 | Reset Mode |
| 6-45 | Term. X30/12 High Ref./Feedb. Value | 8-55 | Set-up Select | 10-01 | Baud Rate Select | 12-40 | Status Parameter | 14-21 | Automatic Restart Time |
| 6-46 | Term. X30/12 Filter Time Constant | 8-56 | Preset Reference Select | 10-02 | MAC ID | 12-41 | Slave Message Count | 14-22 | Operation Mode |
| 6-47 | Term. X30/12 Live Zero | 8-57 | BACnet | 10-05 | Readout Transmit Error Counter | 12-8* | Other Ethernet Services | 14-23 | Typecode Setting |
| 6-50 | Terminal 42 Output | 8-70 | BACnet Device Instance | 10-07 | Readout Bus Off Counter | 12-80 | FTP Server | 14-26 | Trip Delay at Inverter Fault |
| 6-51 | Terminal 42 Output Min Scale | 8-73 | MS/TP Max Masters | 10-10 | DeviceNet | 12-81 | HTTP Server | 14-28 | Production Settings |
| 6-52 | Terminal 42 Output Max Scale | 8-74 | MS/TP Max Info Frames | 10-11 | Process Data Type Selection | 12-82 | SMTP Service | 14-29 | Service Code |
| 6-53 | Terminal 42 Output Bus Control | 8-75 | "I-Am" Service | 10-12 | Process Data Config Write | 12-89 | Transparent Socket Channel Port | 14-3* | Current Limit Ctrl. |
| 6-54 | Terminal 42 Output Timeout Preset | 8-80 | Initialisation Password | 10-13 | Process Data Config Read | 12-9* | Advanced Ethernet Services | 14-30 | Current Lim Ctrl, Proportional Gain |
| 6-55 | Terminal 42 Output Filter | 8-80 | FC Port Diagnostics | 10-14 | Warning Parameter | 12-90 | Cable Diagnostic | 14-31 | Current Lim Ctrl, Integration Time |
| 6-6* | Analog Output X30/8 | 8-81 | Bus Message Count | 10-15 | Net Reference | 12-91 | MDIX | 14-32 | Current Lim Ctrl, Filter Time |
| 6-60 | Terminal X30/8 Output | 8-82 | Bus Error Count | 10-2* | Net Control | 12-92 | IGMP Snooping | 14-4* | Energy Optimising |
| 6-61 | Terminal X30/8 Min. Scale | 8-83 | Slave Message Rcvd | 10-20 | COS Filters | 12-93 | Cable Error Length | 14-40 | VT Level |
| 6-62 | Terminal X30/8 Max. Scale | 8-9* | Slave Error Count | 10-20 | COS Filter 1 | 12-94 | Broadcast Storm Protection | 14-41 | AEO Minimum Magnetisation |
| 6-63 | Terminal X30/8 Output Bus Control | 8-90 | Bus Jog / Feedback | 10-21 | COS Filter 2 | 12-95 | Broadcast Storm Filter | 14-42 | Minimum AEO Frequency |
| 6-64 | Terminal X30/8 Output Timeout Preset | 8-91 | Bus Jog 1 Speed | 10-22 | COS Filter 3 | 12-96 | Port Mirroring | 14-43 | Motor Cosphi |
| 6-7* | Analog Output X45/1 | 8-94 | Bus Feedback 1 | 10-23 | COS Filter 4 | 12-98 | Interface Counters | 14-5* | Environment |
| 6-70 | Terminal X45/1 Output | 8-95 | Bus Feedback 2 | 10-3* | Parameter Access | 12-99 | Media Counters | 14-50 | RFI Filter |
| 6-71 | Terminal X45/1 Min. Scale | 8-96 | Bus Feedback 3 | 10-31 | Array Index | 13-** | Smart Logic | 14-51 | DC Link Compensation |
| 6-72 | Terminal X45/1 Max. Scale | 9-00 | PROFdrive | 10-32 | Store Data Values | 13-0* | SLC Settings | 14-52 | Fan Control |
| 6-73 | Terminal X45/1 Bus Control | 9-00 | Setpoint | 10-32 | DeviceNet Revision | 13-00 | SL Controller Mode | 14-53 | Fan Monitor |
| 6-74 | Terminal X45/1 Output Timeout Preset | 9-07 | Actual Value | 10-33 | Store Always | 13-01 | Start Event | 14-55 | Output Filter |
| 6-8* | Analog Output X45/3 | 9-15 | PCD Write Configuration | 10-34 | DeviceNet Product Code | 13-02 | Stop Event | 14-59 | Actual Number of Inverter Units |
| 6-80 | Terminal X45/3 Output | 9-16 | PCD Read Configuration | 12-** | DeviceNet F Parameters | 13-03 | Reset SLC | 14-6* | Auto Derate |
| 6-81 | Terminal X45/3 Min. Scale | 9-18 | Node Address | 13-1* | Ethernet | 13-1* | Comparators | 14-60 | Function at Over Temperature |
| 6-82 | Terminal X45/3 Max. Scale | 9-22 | Telegram Selection | 13-10 | IP Settings | 13-10 | Comparator Operand | 14-61 | Function at Inverter Overload |
| 6-83 | Terminal X45/3 Bus Control | 9-23 | Parameters for Signals | 12-00 | IP Address Assignment | 13-11 | Comparator Operator | 14-62 | Inv. Overload Derate Current |
| 6-84 | Terminal X45/3 Output Timeout Preset | 9-27 | Parameter Edit | 12-01 | IP Address | 13-12 | Comparator Value | 14-8* | Options |
| 8-8* | Comm. and Options | 9-28 | Process Control | 12-02 | Subnet Mask | 13-2* | Timers | 14-80 | Option Supplied by External 24VDC |
| 8-0* | General Settings | 9-31 | Safe Address | 12-03 | Default Gateway | 13-20 | SL Controller Timer | 14-9* | Fault Settings |
| 8-01 | Control Site | 9-44 | Fault Message Counter | 12-04 | DHCP Server | 13-4* | Logic Rules | 14-90 | Fault Level |
| 8-02 | Control Source | 9-45 | Fault Code | 12-05 | Lease Expires | 13-40 | Logic Rule Boolean 1 | 15-** | Drive Information |
| 8-03 | Control Timeout Time | 9-47 | Fault Number | 12-06 | Name Servers | 13-41 | Logic Rule Operator 1 | 15-0* | Operating Data |
| 8-04 | Control Timeout Function | 9-52 | Fault Situation Counter | 12-07 | Domain Name | 13-42 | Logic Rule Boolean 2 | 15-00 | Operating hours |
| 8-05 | End-of-Timeout Function | 9-53 | Profibus Warning Word | 12-08 | Host Name | 13-43 | Logic Rule Operator 2 | 15-01 | Running Hours |
| 8-06 | Reset Control Timeout | 9-63 | Actual Baud Rate | 12-09 | Physical Address | 13-44 | Logic Rule Boolean 3 | 15-02 | kWh Counter |
| 8-07 | Diagnosis Trigger | 9-64 | Device Identification | 12-1* | Ethernet Link Parameters | 13-5* | States | 15-03 | Power Up's |
| 8-08 | Readout Filtering | 9-65 | Profile Number | 12-10 | Link Status | 13-51 | SL Controller Event | 15-04 | Over Temp's |
| 8-1* | Control Settings | 9-67 | Control Word 1 | 12-11 | Link Duration | 13-52 | SL Controller Action | 15-05 | Over Volt's |
| 8-10 | Control Profile | 9-68 | Status Word 1 | 12-12 | Auto Negotiation | 13-9* | User Defined Alerts | 15-06 | Reset kWh Counter |
| 8-13 | Configurable Status Word STW | 9-70 | Programming Set-up | 12-13 | Link Speed | 13-90 | Alert Trigger | 15-07 | Reset Running Hours Counter |
| 8-14 | Configurable Control Word CTW | 9-71 | Profibus Save Data Values | 12-14 | Link Duplex | 13-91 | Alert Action | 15-08 | Number of Starts |
| 8-3* | FC Port Settings | 9-72 | ProfibusDriveReset | 12-2* | Process Data | 13-92 | Alert Text | 15-1* | Data Log Settings |
| 8-30 | Protocol | 9-75 | DO Identification | 12-20 | Control Instance | 13-9* | User Defined Readouts | 15-10 | Logging Source |
| 8-31 | Address | 9-80 | Defined Parameters (1) | 12-21 | Process Data Config Write | 13-97 | Alert Alarm Word | 15-11 | Logging Interval |
| 8-32 | Baud Rate | 9-81 | Defined Parameters (2) | 12-22 | Process Data Config Read | 13-98 | Alert Warning Word | 15-12 | Trigger Event |
| 8-33 | Parity / Stop Bits | 9-82 | Defined Parameters (3) | 12-27 | Primary Master | 13-99 | Alert Status Word | 15-13 | Logging Mode |
| 8-35 | Minimum Response Delay | 9-83 | Defined Parameters (4) | 12-28 | Store Data Values | 14-** | Special Functions | 15-14 | Samples Before Trigger |
| 8-36 | Max Response Delay | 9-84 | Defined Parameters (5) | 12-29 | Store Always | 14-0* | Inverter Switching | 15-2* | Historic Log |
| 8-37 | Maximum Inter-Char Delay | 9-85 | Defined Parameters (6) | 12-30 | EtherNet/IP | 14-00 | Switching Pattern | 15-20 | Historic Log: Event |
| 8-4* | FC MC protocol set | 9-90 | Changed Parameters (1) | 12-30 | Warning Parameter | 14-01 | Switching Frequency | 15-21 | Historic Log: Value |
| 8-40 | Telegram Selection | 9-91 | Changed Parameters (2) | 12-31 | Net Reference | 14-03 | Overmodulation | 15-22 | Historic Log: Time |
| 8-42 | PCD Write Configuration | 9-92 | Changed Parameters (3) | 12-32 | Net Control | 14-04 | PWM Random | 15-23 | Historic log: Date and Time |
| 8-43 | PCD Read Configuration | 9-93 | Changed Parameters (4) | 12-33 | CIP Revision | 14-1* | Mains On/Off | 15-3* | Alarm Log |
| 8-5* | Digital/Bus | 9-94 | Changed Parameters (5) | 14-10 | Mains Failure | 14-10 | Mains Voltage at Mains Fault | 15-30 | Alarm Log: Error Code |
| 8-50 | Coasting Select | 9-99 | Profibus Revision Counter | 12-35 | EDS Parameter | 14-11 | Mains Voltage at Mains Imbalance | 15-31 | Alarm Log: Value |
| 8-52 | DC Brake Select | 10-** | CAN Fieldbus | 12-37 | COS Inhibit Timer | 14-12 | Function at Mains Imbalance | 15-32 | Alarm Log: Time |
| 8-53 | Start Select | 10-0* | Common Settings | 12-38 | COS Filter | 14-2* | Reset Functions | 15-33 | Alarm Log: Date and Time |



| 18-00* | Info & Readouts | 21-00* | Ext. CL Autotuning | 22-01 | Power Filter Time |
|--------|--------------------------------|--------|-------------------------------|-------|--|
| 18-00* | Maintenance Log | 21-00* | Ext. CL Autotuning | 22-01 | No-Flow Detection |
| 18-00 | Maintenance Log: Item | 21-00 | Closed Loop Type | 22-20 | Low Power Auto Set-up |
| 18-01 | Maintenance Log: Action | 21-01 | PID Performance | 22-21 | Low Power Detection |
| 18-02 | Maintenance Log: Time | 21-02 | PID Output Change | 22-22 | Low Speed Detection |
| 18-03 | Maintenance Log: Date and Time | 21-03 | Minimum Feedback Level | 22-23 | No-Flow Function |
| 18-30 | Analog Input X42/1 | 21-04 | Minimum Feedback Level | 22-24 | No-Flow Delay |
| 18-31 | Analog Input X42/3 | 21-09 | PID Auto Tuning | 22-26 | Dry Pump Function |
| 18-32 | Analog Input X42/5 | 21-1* | Ext. CL 1 Ref./Fb. | 22-27 | Dry Pump Delay |
| 18-33 | Analog Input X42/7 [V] | 21-10 | Ext. 1 Ref./Feedback Unit | 22-28 | No-Flow Low Speed [RPM] |
| 18-34 | Analog Out X42/9 [V] | 21-11 | Ext. 1 Minimum Reference | 22-29 | No-Flow Low Speed [Hz] |
| 18-35 | Analog Out X42/11 [V] | 21-12 | Ext. 1 Maximum Reference | 22-30 | No-Flow Power |
| 18-36 | Analog Input X48/2 [mA] | 21-13 | Ext. 1 Reference Source | 22-31 | No-Flow Power Tuning |
| 18-37 | Temp. input X48/4 | 21-14 | Ext. 1 Feedback Source | 22-30 | No-Flow Power |
| 18-38 | Temp. input X48/7 | 21-15 | Ext. 1 Setpoint | 22-32 | Low Speed [RPM] |
| 18-39 | Temp. input X48/10 | 21-17 | Ext. 1 Reference [Unit] | 22-33 | Low Speed [Hz] |
| 18-5* | Ref. & Feeds. | 21-18 | Ext. 1 Feedback [Unit] | 22-34 | Low Speed Power [kW] |
| 18-50 | Sensorless Readout [unit] | 21-19 | Ext. 1 Output [%] | 22-35 | Low Speed Power [HP] |
| 18-6* | Inputs & Outputs 2 | 21-2* | Ext. CL 1 PID | 22-36 | High Speed [RPM] |
| 18-60 | Digital Input 2 | 21-20 | Ext. 1 Normal/Inverse Control | 22-37 | High Speed [Hz] |
| 20-0* | Drive Closed Loop | 21-21 | Ext. 1 Proportional Gain | 22-38 | High Speed Power [kW] |
| 20-00 | Feedback 1 Source | 21-22 | Ext. 1 Integral Time | 22-39 | High Speed Power [HP] |
| 20-01 | Feedback 1 Conversion | 21-23 | Ext. 1 Differentiation Time | 22-4* | Sleep Mode |
| 20-02 | Feedback 1 Source Unit | 21-24 | Ext. 1 Dif. Gain Limit | 22-40 | Minimum Run Time |
| 20-03 | Feedback 2 Source | 21-30 | Ext. CL 2 Ref./Fb. | 22-41 | Minimum Sleep Time |
| 20-04 | Feedback 2 Conversion | 21-31 | Ext. 2 Ref./Feedback Unit | 22-42 | Wake-up Speed [RPM] |
| 20-05 | Feedback 2 Source Unit | 21-32 | Ext. 2 Minimum Reference | 22-43 | Wake-up Speed [Hz] |
| 20-06 | Feedback 3 Source | 21-33 | Ext. 2 Maximum Reference | 22-44 | Wake-up Ref./FB Difference |
| 20-07 | Feedback 3 Conversion | 21-34 | Ext. 2 Reference Source | 22-45 | Setpoint Boost |
| 20-08 | Feedback 3 Source Unit | 21-35 | Ext. 2 Feedback Source | 22-46 | Maximum Boost Time |
| 20-12 | Reference/Feedback Unit | 21-37 | Ext. 2 Setpoint | 22-5* | End of Curve |
| 20-2* | Feedback/Setpoint | 21-38 | Ext. 2 Reference [Unit] | 22-50 | End of Curve Function |
| 20-20 | Feedback Function | 21-39 | Ext. 2 Feedback [Unit] | 22-51 | End of Curve Delay |
| 20-21 | Setpoint 1 | 21-4* | Ext. CL 2 PID | 22-60 | Broken Belt Function |
| 20-22 | Setpoint 2 | 21-40 | Ext. 2 Normal/Inverse Control | 22-61 | Broken Belt Torque |
| 20-23 | Setpoint 3 | 21-41 | Ext. 2 Proportional Gain | 22-62 | Broken Belt Delay |
| 20-6* | Sensorless | 21-42 | Ext. 2 Integral Time | 22-7* | Short Cycle Protection |
| 20-60 | Sensorless Unit | 21-43 | Ext. 2 Differentiation Time | 22-75 | Short Cycle Protection Interval between Starts |
| 20-69 | Sensorless Information | 21-44 | Ext. 2 Dif. Gain Limit | 22-77 | Minimum Run Time |
| 20-7* | PID Autotuning | 21-5* | Ext. CL 3 Ref./Fb. | 22-78 | Minimum Run Time Override |
| 20-70 | Closed Loop Type | 21-50 | Ext. 3 Ref./Feedback Unit | 22-79 | Minimum Run Time Override Value |
| 20-71 | PID Performance | 21-51 | Ext. 3 Minimum Reference | 22-8* | Flow Compensation |
| 20-72 | PID Output Change | 21-52 | Ext. 3 Maximum Reference | 22-80 | Flow Compensation |
| 20-73 | Minimum Feedback Level | 21-53 | Ext. 3 Reference Source | 22-81 | Square-linear Curve Approximation |
| 20-74 | Maximum Feedback Level | 21-54 | Ext. 3 Feedback Source | 22-82 | Work Point Calculation |
| 20-79 | PID Autotuning | 21-55 | Ext. 3 Setpoint | 22-83 | Speed at No-Flow [RPM] |
| 20-8* | PID Basic Settings | 21-57 | Ext. 3 Reference [Unit] | 22-84 | Speed at No-Flow [Hz] |
| 20-81 | PID Normal/Inverse Control | 21-58 | Ext. 3 Feedback [Unit] | 22-85 | Speed at Design Point [RPM] |
| 20-82 | PID Start Speed [RPM] | 21-59 | Ext. 3 Output [%] | 22-86 | Speed at Design Point [Hz] |
| 20-83 | PID Start Speed [Hz] | 21-60 | Ext. 3 Normal/Inverse Control | 22-87 | Pressure at No-Flow Speed |
| 20-84 | On Reference Bandwidth | 21-61 | Ext. 3 Proportional Gain | 22-88 | Pressure at Rated Speed |
| 20-9* | PID Controller | 21-62 | Ext. 3 Integral Time | 22-89 | Flow at Design Point |
| 20-91 | PID Anti Windup | 21-63 | Ext. 3 Differentiation Time | 22-90 | Flow at Rated Speed |
| 20-93 | PID Proportional Gain | 21-64 | Ext. 3 Dif. Gain Limit | 23-0* | Time-based Functions |
| 20-94 | Ext. Status Word 2 | 22-0* | Appl. Functions | 23-0* | Timed Actions |
| 20-95 | PID Differentiation Time | 22-00* | Miscellaneous | 23-00 | ON Time |
| 20-96 | PID Diff. Gain Limit | 22-00 | External Interlock Delay | 23-01 | ON Action |

| | | | | | | | | | |
|-------|---------------------------|--------|------------------------------------|-------|----------------------------------|-------|-------------------------------------|--------|------------------------------------|
| 23-02 | OFF Time | 25-43 | Destaging Threshold | 26-50 | Terminal X42/9 Output | 27-6* | Digital Inputs | 31-1** | Bypass Option |
| 23-03 | OFF Action | 25-44 | Staging Speed [RPM] | 26-51 | Terminal X42/9 Min. Scale | 27-60 | Terminal X66/1 Digital Input | 31-00 | Bypass Mode |
| 23-04 | Occurrence | 25-45 | Staging Speed [Hz] | 26-52 | Terminal X42/9 Max. Scale | 27-61 | Terminal X66/3 Digital Input | 31-01 | Bypass Start Time Delay |
| 23-1* | Maintenance | 25-46 | Destaging Speed [RPM] | 26-53 | Terminal X42/9 Bus Control | 27-62 | Terminal X66/5 Digital Input | 31-02 | Bypass Trip Time Delay |
| 23-10 | Maintenance Item | 25-47 | Destaging Speed [Hz] | 26-54 | Terminal X42/9 Timeout Preset | 27-63 | Terminal X66/7 Digital Input | 31-03 | Test Mode Activation |
| 23-11 | Maintenance Action | 25-5* | Alternation Settings | 26-6* | Analog Out X42/11 | 27-64 | Terminal X66/9 Digital Input | 31-10 | Bypass Status Word |
| 23-12 | Maintenance Time Base | 25-50 | Lead Pump Alternation | 26-60 | Terminal X42/11 Output | 27-65 | Terminal X66/11 Digital Input | 31-11 | Bypass Running Hours |
| 23-13 | Maintenance Time Interval | 25-51 | Alternation Event | 26-61 | Terminal X42/11 Min. Scale | 27-66 | Terminal X66/13 Digital Input | 31-19 | Remote Bypass Activation |
| 23-14 | Maintenance Date and Time | 25-52 | Alternation Time Interval | 26-62 | Terminal X42/11 Max. Scale | 27-7* | Connections | 35-2** | Sensor Input Option |
| 23-15 | Reset Maintenance Word | 25-53 | Alternation Timer Value | 26-63 | Terminal X42/11 Bus Control | 27-70 | Relay | 35-0* | Temp. Input Mode |
| 23-16 | Maintenance Text | 25-54 | Alternation Predefined Time | 26-64 | Terminal X42/11 Timeout Preset | 27-9* | Readouts | 35-00 | Term. X48/4 Temperature Unit |
| 23-5* | Energy Log | 25-56 | Staging Mode at Alternation | 27-0* | Cascade CTL Option | 27-91 | Cascade Reference | 35-01 | Term. X48/4 Input Type |
| 23-50 | Energy Log Resolution | 25-58 | Run Next Pump Delay | 27-01 | Control & Status | 27-92 | % Of Total Capacity | 35-02 | Term. X48/7 Temperature Unit |
| 23-51 | Period Start | 25-59 | Run on Mains Delay | 27-02 | Manual Pump Control | 27-93 | Cascade Option Status | 35-03 | Term. X48/7 Input Type |
| 23-53 | Energy Log | 25-8* | Status | 27-03 | Current Runtime Hours | 27-94 | Cascade System Status | 35-04 | Term. X48/10 Temperature Unit |
| 23-54 | Reset Energy Log | 25-80 | Cascade Status | 27-04 | Pump Total Lifetime Hours | 27-95 | Advanced Cascade Relay Output [bin] | 35-05 | Term. X48/10 Input Type |
| 23-6* | Trending | 25-81 | Pump Status | 27-1* | Configuration | 27-96 | Extended Cascade Relay Output [bin] | 35-06 | Temperature Sensor Alarm Function |
| 23-60 | Trend Variable | 25-82 | Lead Pump | 27-10 | Cascade Controller | 29-0* | Water Application Functions | 35-1* | Temp. Input X48/4 |
| 23-61 | Continuous Bin Data | 25-83 | Relay Status | 27-11 | Number Of Drives | 29-00 | Pipe Fill | 35-14 | Term. X48/4 Filter Time Constant |
| 23-62 | Timed Bin Data | 25-84 | Pump ON Time | 27-12 | Number Of Pumps | 29-01 | Pipe Fill Enable | 35-15 | Term. X48/4 Temp. Monitor |
| 23-63 | Timed Period Start | 25-85 | Relay ON Time | 27-14 | Pump Capacity | 29-02 | Pipe Fill Speed [RPM] | 35-16 | Term. X48/4 Low Temp. Limit |
| 23-64 | Timed Period Stop | 25-86 | Reset Relay Counters | 27-16 | Runtime Balancing | 29-03 | Pipe Fill Time | 35-17 | Term. X48/4 High Temp. Limit |
| 23-65 | Minimum Bin Value | 25-9* | Service | 27-17 | Motor Starters | 29-04 | Pipe Fill Rate | 35-2** | Temp. Input X48/7 |
| 23-66 | Reset Continuous Bin Data | 25-90 | Pump Interlock | 27-18 | Spin Time for Unused Pumps | 29-05 | Filled Setpoint | 35-24 | Term. X48/7 Filter Time Constant |
| 23-67 | Reset Timed Bin Data | 25-91 | Manual Alternation | 27-19 | Reset Current Runtime Hours | 29-06 | No-Flow Disable Timer | 35-25 | Term. X48/7 Temp. Monitor |
| 23-8* | Payback Counter | 26-2** | Analog I/O Option | 27-2* | Bandwidth Settings | 29-1* | Deragging Function | 35-27 | Term. X48/7 High Temp. Limit |
| 23-80 | Power Reference Factor | 26-0* | Analog I/O Mode | 27-20 | Normal Operating Range | 29-10 | Derag Cycles | 35-3* | Temp. Input X48/10 |
| 23-81 | Energy Cost | 26-00 | Terminal X42/1 Mode | 27-21 | Override Limit | 29-11 | Derag at Start/Stop | 35-34 | Term. X48/10 Filter Time Constant |
| 23-82 | Investment | 26-01 | Terminal X42/3 Mode | 27-22 | Fixed Speed Only Operating Range | 29-12 | Deragging Run Time | 35-35 | Term. X48/10 Temp. Monitor |
| 23-83 | Energy Savings | 26-02 | Terminal X42/5 Mode | 27-23 | Staging Delay | 29-13 | Derag Speed [RPM] | 35-36 | Term. X48/10 Low Temp. Limit |
| 23-84 | Cost Savings | 26-1* | Analog Input X42/1 | 27-24 | Destaging Delay | 29-14 | Derag Speed [Hz] | 35-37 | Term. X48/10 High Temp. Limit |
| 24-1* | Drive Bypass | 26-10 | Terminal X42/1 Low Voltage | 27-25 | Override Hold Time | 29-15 | Derag Off Delay | 35-4* | Analog Input X48/2 |
| 24-10 | Drive Bypass Function | 26-11 | Terminal X42/1 High Voltage | 27-27 | Min Speed Destage Delay | 29-2* | Derag Power Tuning | 35-42 | Term. X48/2 Low Current |
| 24-11 | Drive Bypass Delay Time | 26-14 | Term. X42/1 Low Ref./Feedb. Value | 27-3* | Staging Speed | 29-20 | Derag Power [kW] | 35-43 | Term. X48/2 High Current |
| 25-0* | Cascade Controller | 26-15 | Term. X42/1 High Ref./Feedb. Value | 27-30 | Auto Tune Staging Speeds | 29-21 | Derag Power [HP] | 35-44 | Term. X48/2 Low Ref./Feedb. Value |
| 25-00 | Cascade Controller | 26-16 | Term. X42/1 Filter Time Constant | 27-31 | Stage On Speed [RPM] | 29-22 | Derag Power Factor | 35-45 | Term. X48/2 High Ref./Feedb. Value |
| 25-02 | Motor Start | 26-17 | Term. X42/1 Live Zero | 27-32 | Stage On Speed [Hz] | 29-23 | Derag Power Delay | 35-46 | Term. X48/2 Filter Time Constant |
| 25-04 | Pump Cycling | 26-2* | Analog Input X42/3 | 27-33 | Stage Off Speed [RPM] | 29-24 | Low Speed [RPM] | 35-47 | Term. X48/2 Live Zero |
| 25-05 | Fixed Lead Pump | 26-20 | Terminal X42/3 Low Voltage | 27-34 | Stage Off Speed [Hz] | 29-25 | Low Speed [Hz] | | |
| 25-06 | Number of Pumps | 26-21 | Terminal X42/3 High Voltage | 27-4* | Staging Settings | 29-26 | Low Speed Power [kW] | | |
| 25-2* | Bandwidth Settings | 26-24 | Term. X42/3 Low Ref./Feedb. Value | 27-40 | Auto Tune Staging Settings | 29-27 | Low Speed Power [HP] | | |
| 25-20 | Staging Bandwidth | 26-25 | Term. X42/3 High Ref./Feedb. Value | 27-41 | Ramp Down Delay | 29-28 | High Speed [RPM] | | |
| 25-21 | Override Bandwidth | 26-26 | Term. X42/3 Filter Time Constant | 27-42 | Ramp Up Delay | 29-29 | High Speed [Hz] | | |
| 25-22 | Fixed Speed Bandwidth | 26-27 | Term. X42/3 Live Zero | 27-43 | Staging Threshold | 29-30 | High Speed Power [kW] | | |
| 25-23 | SBW Staging Delay | 26-30 | Terminal X42/5 Low Voltage | 27-44 | Destaging Threshold | 29-31 | High Speed Power [HP] | | |
| 25-24 | SBW Destaging Delay | 26-31 | Terminal X42/5 High Voltage | 27-45 | Staging Speed [RPM] | 29-32 | Derag On Ref Bandwidth | | |
| 25-25 | OBW Time | 26-34 | Term. X42/5 Low Ref./Feedb. Value | 27-46 | Staging Speed [Hz] | 29-33 | Power Derag Limit | | |
| 25-26 | Destage At No-Flow | 26-35 | Term. X42/5 High Ref./Feedb. Value | 27-47 | Destaging Speed [RPM] | 29-34 | Consecutive Derag Interval | | |
| 25-27 | Stage Function | 26-36 | Term. X42/5 Filter Time Constant | 27-48 | Destaging Speed [Hz] | 29-4* | Pre/Post Lube | | |
| 25-28 | Stage Function Time | 26-37 | Term. X42/5 Live Zero | 27-50 | Automatic Alternation | 29-40 | Pre/Post Lube Function | | |
| 25-29 | Destage Function | 26-40 | Analog Out X42/7 | 27-51 | Alternation Event | 29-41 | Pre Lube Time | | |
| 25-30 | Destage Function Time | 26-41 | Terminal X42/7 Min. Scale | 27-52 | Alternation Time Interval | 29-42 | Post Lube Time | | |
| 25-4* | Staging Settings | 26-42 | Terminal X42/7 Max. Scale | 27-53 | Alternation Timer Value | 29-5* | Flow Confirmation | | |
| 25-40 | Ramp Down Delay | 26-43 | Terminal X42/7 Bus Control | 27-54 | Alternation At Time of Day | 29-50 | Validation Time | | |
| 25-41 | Ramp Up Delay | 26-44 | Terminal X42/7 Timeout Preset | 27-55 | Alternation Predefined Time | 29-51 | Verification Time | | |
| 25-42 | Staging Threshold | 26-5* | Analog Out X42/9 | 27-56 | Alternate Capacity is < | 30-8* | Special Features | | |
| | | | | 27-58 | Run Next Pump Delay | 30-81 | Compatibility (I) | | |
| | | | | | | | | | |

Index

A

Abbreviation..... 77

AC

- input..... 0
- mains..... 0
- waveform..... 0

AC input..... 17

AC mains..... 17

Additional resources..... 4

Alarm log..... 23

Alarms..... 37

AMA..... 35, 39, 42

Ambient conditions..... 64

Analog input..... 18, 38, 65

Analog output..... 18, 65

Analog signal..... 38

Analog speed reference..... 32

Approval..... 8

Auto on..... 24, 30, 35, 37

Automatic energy optimisation..... 29

Automatic motor adaptation..... 29

Auto-reset..... 22

Auxiliary equipment..... 21

B

Back plate..... 12

Braking..... 35, 40

C

Cable

- routing..... 21
- Motor cable..... 13, 16, 0 , 62
- Motor cable length..... 64
- Specifications..... 64

Certification..... 8

Circuit breaker..... 21, 68, 69, 70

Clearance requirements..... 11

Closed loop..... 19

Communication option..... 41

Conduct..... 21

Control

- characteristic..... 67

Control card

- Control card..... 38
- Control card performance..... 67
- Control card, 10 V DC output..... 67
- Control card, 24 V DC output..... 66
- Control card, RS485 serial communication..... 64
- USB serial communication..... 67

Control signal..... 35

Control terminal..... 24, 26, 35, 37

Control wiring..... 13, 15, 19, 21

Convention..... 77

Cooling..... 11, 62

Cooling clearance..... 21

Cos φ..... 63, 66

Current

- level..... 65
- limit..... 46
- mode..... 65
- range..... 65
- rating..... 39
- DC current..... 0 , 13
- Input current..... 17
- Output current..... 36

D

DC current..... 36

DC link..... 38

Default setting..... 24

Derating

- Derating..... 64

Digital input..... 18, 19, 37, 39, 65

Digital output..... 66

Dimensions..... 75, 76

Discharge time..... 9

Disconnect switch..... 22

Displacement power factor..... 63

E

Efficiency..... 62, 64

Electrical interference..... 13

EMC..... 13

EMC interference..... 15

Environment..... 64

Exploded view..... 6, 7

External alarm reset..... 33

External command..... 0 , 8, 37

External controllers..... 4

External interlock..... 33

F

Fault log..... 23
 FC..... 20
 Feedback..... 19, 21, 31, 36, 42, 44
 Floating delta..... 17
 Fuse..... 13, 21, 41, 45, 68, 69, 70, 71, 72, 73, 74

G

Ground connection..... 21
 Ground wire..... 13
 Grounded delta..... 17
 Grounding..... 16, 17, 21, 22

H

Hand on..... 24, 35
 Harmonics
 Harmonics..... 0, 8
 High altitude..... 64
 High voltage..... 9, 22
 Humidity..... 64

I

IEC 61800-3..... 17
 Initialisation..... 25
 Input disconnect..... 17
 Input power..... 0, 13, 15, 17, 21, 22, 37, 45
 Input power wiring..... 21
 Input signal..... 19
 Input terminal..... 17, 19, 22, 38
 Input voltage..... 22
 Installation..... 19, 20, 21
 Installation environment..... 11
 Intended use..... 4
 Interference isolation..... 21
 Interlock..... 32
 Isolated main..... 17
 Items supplied..... 11

J

Jumper..... 19

L

Leakage current..... 10, 13
 Lifting..... 12
 Load sharing..... 9, 49, 50, 51, 52, 53, 54, 55, 56, 57, 58, 59, 60, 61, 62

Local control..... 22, 24, 35
 Local control panel (LCP)..... 22

M

Main menu..... 23
 Mains
 voltage..... 23, 35
 Transient..... 8
 Maintenance..... 35
 Manual initialisation..... 25
 MCT 10..... 18, 22
 Menu key..... 22, 23
 Menu structure..... 23
 Modbus RTU..... 20

Motor

current..... 0, 8, 23, 29, 42
 data..... 26, 29, 39, 43, 46
 output..... 63
 power..... 13, 23, 42
 rotation..... 29
 speed..... 25
 status..... 4
 thermistor..... 34
 wiring..... 15, 21
 Output current..... 39
 Output performance (U, V, W)..... 63
 Thermistor..... 34

Motor thermal protection..... 34

Mounting..... 12, 21

Multiple frequency converters..... 13

N

Nameplate..... 11
 Navigation key..... 22, 23, 25, 35

O

Open loop..... 19
 Operation key..... 22
 Optional equipment..... 17, 19, 22
 Output power wiring..... 21
 Output terminal..... 22
 Overcurrent protection..... 13
 Overload
 High overload..... 62, 63
 Normal overload..... 48, 52, 63
 torque..... 63
 Overvoltage..... 36, 46, 63, 66

P

Parameter menu structure..... 78
 PELV..... 34, 64, 65, 66, 67

| | | | |
|---------------------------------|------------------------|----------------------------------|----------------|
| Phase loss..... | 38 | Specifications..... | 20 |
| PM Motor..... | 27 | Speed reference..... | 19, 30, 32, 35 |
| Potential equalisation..... | 13 | Start-up..... | 25 |
| Potentiometer..... | 32 | Status display..... | 35 |
| Power connection..... | 13 | Status mode..... | 35 |
| Power factor..... | 0, 21, 63 | STO..... | 20 |
| Programming..... | 19, 22, 23, 24, 38 | Storage..... | 11, 64 |
| Pulse input..... | 66 | Supply voltage..... | 17, 18, 22, 41 |
| Q | | Switch..... | 19 |
| Qualified personnel..... | 9 | Switching frequency..... | 36 |
| Quick menu..... | 23 | Symbol..... | 77 |
| R | | System feedback..... | 4 |
| Ramp-down time..... | 46 | T | |
| Ramp-up time..... | 46 | Terminal 53..... | 19 |
| Reference..... | 23, 35, 36 | Terminal 54..... | 19 |
| Reference | | Terminal tightening torques..... | 67 |
| Reference..... | 31, 0 | Thermal protection..... | 8 |
| Relay | | Thermistor..... | 17, 39 |
| Relay..... | 18 | Thermistor control wiring..... | 17 |
| 1..... | 66 | Torque | |
| 2..... | 66 | Starting torque..... | 63 |
| output..... | 66 | characteristic..... | 63 |
| Remote commands..... | 4 | limit..... | 46 |
| Remote reference..... | 36 | Transient protection..... | 0 |
| Reset..... | 22, 24, 25, 37, 38, 44 | Trip | |
| RFI filter..... | 17 | Trip..... | 34, 37 |
| RMS current..... | 0 | level..... | 68, 69, 70 |
| RS485..... | 34 | lock..... | 37 |
| RS485 serial communication..... | 20 | Troubleshooting..... | 47 |
| Run command..... | 30 | True power factor..... | 63 |
| Run permissive..... | 33, 36 | U | |
| Run/Stop command..... | 32 | UL compliance..... | 71 |
| S | | Unintended motor rotation..... | 10 |
| Safe torque off..... | 20 | Unintended start..... | 9, 35 |
| Safety..... | 10 | V | |
| Screened cable..... | 15, 21 | Vibration..... | 11 |
| Serial communication..... | 18, 24, 35, 36, 37 | Voltage imbalance..... | 38 |
| Service..... | 35 | Voltage level..... | 65 |
| Setpoint..... | 37 | VVC+..... | 27 |
| Set-up..... | 30 | W | |
| Shock..... | 11 | Warnings..... | 37 |
| Short circuit..... | 40 | Weight..... | 75, 76 |
| Sleep mode..... | 37 | Windmilling..... | 10 |
| SmartStart..... | 25 | Wire size..... | 13, 16 |

Wiring schematic..... 14



.....
Danfoss can accept no responsibility for possible errors in catalogues, brochures and other printed material. Danfoss reserves the right to alter its products without notice. This also applies to products already on order provided that such alterations can be made without subsequential changes being necessary in specifications already agreed. All trademarks in this material are property of the respective companies. Danfoss and the Danfoss logotype are trademarks of Danfoss A/S. All rights reserved.
.....

Danfoss A/S
Ulsnaes 1
DK-6300 Graasten
vlt-drives.danfoss.com

