



Programming Guide

VLT[®] AQUA Drive FC 200

Contents

1 Introduction	1-1
1.1.1 Approvals	1-1
1.1.2 Symbols	1-1
1.1.3 Abbreviations	1-1
1.1.4 Definitions	1-2
1.1.5 Electrical Wiring - Control Cables	1-6
2 How to Program	2-1
2.1 The Graphical and Numerical Local Control Panel	2-1
2.2 How to Program on the Graphical LCP	2-1
2.2.1 The LCP Display	2-2
2.2.2 Quick Transfer of Parameter Settings between Multiple Adjustable Frequency Drives	2-4
2.2.3 Display Mode	2-4
2.2.4 Display Mode - Selection of Readouts	2-4
2.2.5 Parameter Set-Up, General Information	2-5
2.2.6 Quick Menu Key Functions	2-5
2.2.7 Quick Menu, Q3 Function Set-ups	2-7
2.2.8 Main Menu Mode	2-8
2.2.9 Parameter Selection	2-8
2.2.10 Changing Data	2-8
2.2.11 Changing a Text Value	2-9
2.2.12 Changing a Group of Numeric Data Values	2-9
2.2.13 Infinitely Variable Change of Numeric Data Value	2-9
2.2.14 Value, Step-by-Step	2-9
2.2.15 Readout and Programming of Indexed Parameters	2-10
2.3 How to Program on the Numerical LCP	2-10
2.3.1 Local Control Keys	2-11
2.4 Initialization to Default Settings	2-12
3 Parameter Description	3-1
3.1 Parameter Selection	3-1
3.2 Parameters 0-** Operation and Display	3-2
3.3 Parameters 1-** Load and Motor	3-15
3.4 Parameters 2-** Brakes	3-29
3.5 Parameters 3-** Reference/Ramps	3-32
3.6 Parameters 4-** Limits/Warnings	3-38
3.7 Parameters 5-** Digital In/Out	3-42

3.8 Parameters 6-** Analog In/Out	3-56
3.9 Parameters 8-** Communications and Options	3-62
3.10 Parameters 9-** Profibus	3-68
3.11 Parameters 10-** CAN Fieldbus	3-68
3.12 Parameters 13-** Smart Logic Control	3-73
3.13 Parameters 14-** Special Functions	3-85
3.14 Parameters 15-** Adjustable Frequency Drive Information	3-92
3.15 Parameters 16-** Data Readouts	3-98
3.16 Parameters 18-** Data Readouts 2	3-104
3.17 Parameters 20-** FC Closed-loop	3-106
3.18 Parameters 21-** Extended Closed Loop	3-115
3.19 Parameters 22-** Application Functions	3-123
3.20 Parameters 23-** Time-based Functions	3-136
3.21 Parameters 24-** Application Functions 2	3-146
3.22 Parameters 25-** Cascade Controller	3-147
3.23 Parameters 26-** Analog I/O Option MCB 109	3-158
3.24 Parameters 29-** Water Application Functions	3-163
3.25 Parameters 30-** Special Features	3-167
3.26 Parameters 31-** Bypass Option	3-167
3.27 Parameters 35-** Sensor Input Option	3-168
4 Parameter Lists	4-1
4.1 Parameter Options	4-1
4.1.1 Default settings	4-1
4.1.2 Operation/Display 0-**	4-2
4.1.3 Load/Motor 1-**	4-3
4.1.4 Brakes 2-**	4-4
4.1.5 Reference / Ramps 3-**	4-5
4.1.6 Limits / Warnings 4-**	4-6
4.1.7 Digital In/Out 5-**	4-7
4.1.8 Analog In/Out 6-**	4-8
4.1.9 Comm. and Options 8-**	4-9
4.1.10 Profibus 9-**	4-10
4.1.11 CAN Fieldbus 10-**	4-11
4.1.12 Smart Logic 13-**	4-11
4.1.13 Special Functions 14-**	4-12
4.1.14 Adj. Freq. Drive Information 15-**	4-12
4.1.15 Data Readouts 16-**	4-14

4.1.16 Data Readouts 2 18-**	4-15
4.1.17 Adj. Freq. Drive Closed-loop 20-**	4-16
4.1.18 Ext. Closed-loop 21-**	4-17
4.1.19 Application Functions 22-**	4-18
4.1.20 Timed Actions 23-**	4-19
4.1.21 24-** Application Functions 2	4-19
4.1.22 Cascade Controller 25-**	4-20
4.1.23 Analog I/O Option MCB 109 26-**	4-21
4.1.25 Water Application Functions 29-**	4-23
4.1.26 Special Features 30-**	4-23
4.1.27 Bypass Option 31-**	4-24
4.1.28 Sensor Input Option 35-**	4-24
5 Troubleshooting	5-1
5.1.1 Warnings/Alarm Messages	5-1
6 Index	6-1

1 Introduction

Programming Guide
Software version: 1.9x

This Programming Guide can be used for all FC 200 adjustable frequency drives with software version 1.9x. The software version number can be seen from *15-43 Software Version*.

Table 1.1

1.1.1 Approvals

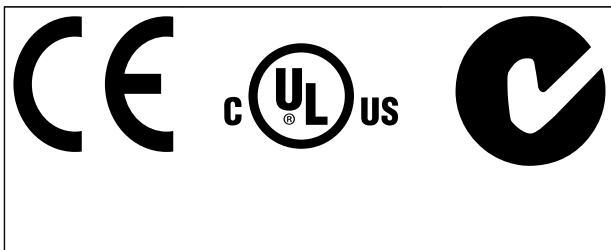

Table 1.2

1.1.2 Symbols

Symbols used in this guide.

NOTICE!

Indicates something to be noted by the reader.

CAUTION

Indicates a potentially hazardous situation which, if not avoided, may result in minor or moderate injury or equipment damage.

WARNING

Indicates a potentially hazardous situation which, if not avoided, could result in death or serious injury.

* Indicates default setting

Table 1.3

1.1.3 Abbreviations

Alternating current	AC
American wire gauge	AWG
Ampere/AMP	A
Automatic Motor Adaptation	AMA
Current limit	I _{LIM}
Degrees Celsius	°C
Direct current	DC
Drive Dependent	D-TYPE
Electro Magnetic Compatibility	EMC
Electronic Thermal Relay	ETR
Adjustable frequency drive	FC
Gram	g
Hertz	Hz
Horsepower	hp
Kilohertz	kHz
Local Control Panel	LCP
Meter	m
Millihenry Inductance	mH
Milliamper	mA
Millisecond	ms
Minute	min
Motion Control Tool	MCT
Nanofarad	nF
Newton Meters	Nm
Nominal motor current	I _{M,N}
Nominal motor frequency	f _{M,N}
Nominal motor power	P _{M,N}
Nominal motor voltage	U _{M,N}
Permanent Magnet motor	PM motor
Protective Extra Low Voltage	PELV
Printed Circuit Board	PCB
Rated Inverter Output Current	I _{INV}
Revolutions Per Minute	RPM
Regenerative terminals	Regen
Second	sec.
Synchronous Motor Speed	n _s
Torque limit	T _{LIM}
Volts	V
The maximum output current	I _{VLT,MAX}
The rated output current supplied by the adjustable frequency drive	I _{VLT,N}

Table 1.4

1.1.4 Definitions

Adjustable frequency drive:

$I_{VLT,MAX}$

Maximum output current.

$I_{VLT,N}$

Rated output current supplied by the adjustable frequency drive.

$U_{VLT,MAX}$

Maximum output voltage.

Input:

Control command

Start and stop the connected motor with LCP and digital inputs.

Functions are divided into two groups.

Functions in group 1 have higher priority than functions in group 2.

Group 1	Reset, Coasting stop, Reset and Coasting stop, Quick stop, DC braking, Stop and the [OFF] key.
Group 2	Start, Pulse start, Reversing, Start reversing, Jog and Freeze output

Table 1.5

Motor:

Motor Running

Torque generated on output shaft and speed from zero rpm to max. speed on motor.

f_{JOG}

Motor frequency when the jog function is activated (via digital terminals).

f_M

Motor frequency.

f_{MAX}

Maximum motor frequency.

f_{MIN}

Minimum motor frequency.

$f_{M,N}$

Rated motor frequency (nameplate data).

I_M

Motor current (actual).

$I_{M,N}$

Rated motor current (nameplate data).

$n_{M,N}$

Rated motor speed (nameplate data).

n_s

Synchronous motor speed

$$n_s = \frac{2 \times \text{par. 1} - 23 \times 60 \text{ s}}{\text{par. 1} - 39}$$

$P_{M,N}$

Rated motor power (nameplate data in kW or HP).

$T_{M,N}$

Rated torque (motor).

U_M

Instantaneous motor voltage.

$U_{M,N}$

Rated motor voltage (nameplate data).

Break-away torque

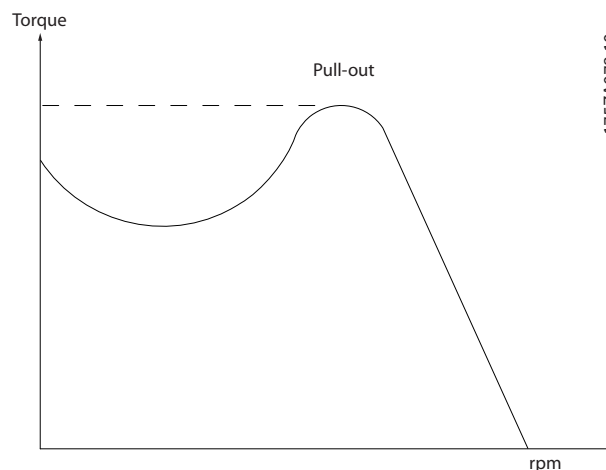

175ZA078.10

Figure 1.1

η_{VLT}

The efficiency of the adjustable frequency drive is defined as the ratio between the power output and the power input.

Start-disable command

A stop command belonging to the group 1 control commands - see this group.

Stop command

See Control commands.

References:

Analog Reference

A signal transmitted to the analog inputs 53 or 54, can be voltage or current.

Binary Reference

A signal transmitted to the serial communication port.

Preset Reference

A defined preset reference to be set from -100% to +100% of the reference range. Selection of eight preset references via the digital terminals.

Pulse Reference

A pulse frequency signal transmitted to the digital inputs (terminal 29 or 33).

RefMAX

Determines the relationship between the reference input at 100% full scale value (typically 10 V, 20 mA) and the resulting reference. The maximum reference value set in *3-03 Maximum Reference*.

RefMIN

Determines the relationship between the reference input at 0% value (typically 0 V, 0 mA, 4 mA) and the resulting reference. The minimum reference value set in *3-02 Minimum Reference*.

Miscellaneous:Analog Inputs

The analog inputs are used for controlling various functions of the adjustable frequency drive.

There are two types of analog inputs:

Current input, 0–20 mA and 4–20 mA

Voltage input, 0–10 V DC

Analog Outputs

The analog outputs can supply a signal of 0–20 mA, 4–20 mA.

Automatic Motor Adaptation, AMA

AMA algorithm determines the electrical parameters for the connected motor at standstill.

Brake Resistor

The brake resistor is a module capable of absorbing the braking energy generated in regenerative braking. This regenerative braking energy increases the intermediate circuit voltage and a brake chopper ensures that the power is transmitted to the brake resistor.

CT Characteristics

Constant torque characteristics used for all applications such as conveyor belts, displacement pumps and cranes.

Digital Inputs

The digital inputs can be used for controlling various adjustable frequency drive functions.

Digital Outputs

The adjustable frequency drive features two solid state outputs that can supply a 24 V DC (max. 40 mA) signal.

DSP

Digital Signal Processor.

ETR

Electronic Thermal Relay is a thermal load calculation based on present load and time. Its purpose is to estimate the motor temperature.

Initializing

If initialization is carried out (*14-22 Operation Mode*), the adjustable frequency drive returns to the default setting.

Intermittent Duty Cycle

An intermittent duty rating refers to a sequence of duty cycles. Each cycle consists of an on-load and an off-load period. The operation can be either periodic duty or non-periodic duty.

LCP

The Local Control Panel makes up a complete interface for control and programming of the adjustable frequency drive. The control panel is detachable and can be installed up to 10 ft [3 m] from the adjustable frequency drive, i.e., in a front panel by means of the installation kit option.

lsb

Least significant bit.

msb

Most significant bit.

MCM

Short for Mille Circular Mil, an American measuring unit for cable cross-sections. 1 MCM = 0.5067 mm².

Online/Offline Parameters

Changes to online parameters are activated immediately after the data value is changed. Changes to offline parameters are not activated before [OK] is entered on the LCP.

Process PID

The PID control maintains the desired speed, flow, pressure, temperature, etc., by adjusting the output frequency to match the varying load.

PCD

Process Control Data

Power Cycle

Switch off line power until display (LCP) is dark – then turn power on again.

RCD

Residual Current Device.

Set-up

Parameter settings can be saved in four set-ups. Change between the four parameter set-ups, and edit one set-up, while another set-up is active.

SFAVM

Switching pattern called Stator Flux oriented Aynchronous Vector Modulation (*14-00 Switching Pattern*).

Slip Compensation

The adjustable frequency drive compensates for the motor slip by giving the frequency a supplement that follows the measured motor load, keeping the motor speed almost constant.

Smart Logic Control (SLC)

The SLC is a sequence of user-defined actions executed when the associated user-defined events are evaluated as true by the Smart Logic Controller. (Parameter group 13-**) *Smart Logic Control (SLC)*.

STW

Status Word

Adjustable Frequency Drive Standard Bus

Includes RS-485 bus with FC protocol or MC protocol. See *8-30 Protocol*.

Thermistor

A temperature-dependent resistor placed where the temperature is to be monitored (adjustable frequency drive or motor).

Trip

A state entered in fault situations, e.g., if the adjustable frequency drive is subject to an overtemperature or when the adjustable frequency drive is protecting the motor, process or mechanism. Restart is prevented until the cause of the fault has disappeared and the trip state is canceled by activating reset or, in some cases, by being programmed to reset automatically. Trip may not be used for personal safety.

Trip Locked

A state entered in fault situations when the adjustable frequency drive is protecting itself and requiring physical intervention, e.g., if the adjustable frequency drive is subject to a short circuit on the output. A locked trip can only be canceled by cutting off line power, removing the cause of the fault, and reconnecting the adjustable frequency drive. Restart is prevented until the trip state is canceled by activating reset or, in some cases, by being programmed to reset automatically. Trip may not be used for personal safety.

VT Characteristics

Variable torque characteristics used for pumps and fans.

VVC^{plus}

If compared with standard voltage/frequency ratio control, Voltage Vector Control (VVC^{plus}) improves the dynamics and the stability, both when the speed reference is changed and in relation to the load torque.

60° AVM

Switching pattern called 60° Asynchronous Vector Modulation (*14-00 Switching Pattern*).

Power Factor

The power factor is the relation between I_1 and I_{RMS} .

$$\text{Power factor} = \frac{\sqrt{3} \times U \times I_1 \cos\varphi}{\sqrt{3} \times U \times I_{RMS}}$$

The power factor for 3-phase control:

$$= \frac{I_1 \times \cos\varphi_1}{I_{RMS}} = \frac{I_1}{I_{RMS}} \text{ since } \cos\varphi_1 = 1$$

The power factor indicates to which extent the adjustable frequency drive imposes a load on the line power supply. The lower the power factor, the higher the I_{RMS} for the same kW [hp] performance.

$$I_{RMS} = \sqrt{I_1^2 + I_5^2 + I_7^2 + \dots + I_n^2}$$

In addition, a high power factor indicates that the different harmonic currents are low.

The built-in DC coils produce a high power factor, which minimizes the imposed load on the line power supply.

⚠ WARNING

The voltage of the adjustable frequency drive is dangerous whenever connected to line power. Incorrect installation of the motor, adjustable frequency drive or serial communication bus may cause death, serious personal injury or damage to the equipment. Consequently, the instructions in this manual, as well as national and local rules and safety regulations, must be complied with.

Safety Regulations

1. Disconnect the line power supply before carrying out repair work. Make sure that the line power supply has been disconnected and that the necessary time has elapsed before removing motor and line power supply plugs.
2. The [Off] key on the LCP does not disconnect the line power supply and consequently it must not be used as a safety switch.
3. The equipment must be properly grounded, the user must be protected against supply voltage and the motor must be protected against overload in accordance with applicable national and local regulations.
4. The ground leakage current exceeds 3.5 mA.
5. Protection against motor overload: If this function is desired, set *1-90 Motor Thermal Protection* for example to data value ETR trip 1 or data value ETR warning 1.
6. Do not remove the plugs for the motor and line power supply while the adjustable frequency

drive is connected to line power. Make sure that the line power supply has been disconnected and that the necessary time has elapsed before removing motor and line power plugs.

7. Note that the adjustable frequency drive has more voltage sources than L1, L2 and L3, when load sharing (linking of DC intermediate circuit) or external 24 V DC are installed. Make sure that all voltage sources have been disconnected and that the necessary time has elapsed before commencing repair work.

Warning against unintended start

1. The motor can be brought to a stop with digital commands, bus commands, references or a local stop, while the adjustable frequency drive is connected to line power. If personal safety considerations (e.g., risk of personal injury caused by contact with moving machine parts following an unintentional start) make it necessary to ensure that no unintended start occurs, these stop functions are not sufficient. In such cases, the line power supply must be disconnected or the Safe Stop function must be activated.
2. The motor may start while setting the parameters. If this means that personal safety may be compromised (e.g., personal injury caused by contact with moving machine parts), motor starting must be prevented, for instance by use of the Safe Stop function or secure disconnection of the motor connection.
3. A motor that has been stopped with the line power supply connected, may start if faults occur in the electronics of the adjustable frequency drive, through temporary overload or if a fault in the power supply grid or motor connection is remedied. If unintended start must be prevented for personal safety reasons (e.g., risk of injury caused by contact with moving machine parts), the normal stop functions of the adjustable frequency drive are not sufficient. In such cases, the line power supply must be disconnected or the Safe Stop function must be activated.

NOTICE!

When using the Safe Stop function, always follow the instructions in the section *Safe Stop* of the *VLT® AQUA Drive Design Guide, MG20N*.

4. Control signals from, or internally within, the adjustable frequency drive may in rare cases be activated in error, be delayed or fail to occur entirely. When used in situations where safety is critical.

▲WARNING

High Voltage

Touching the electrical parts may be fatal - even after the equipment has been disconnected from line power.

Also make sure that other voltage inputs have been disconnected, such as external 24 V DC, load sharing (linkage of DC intermediate circuit), as well as the motor connection for kinetic backup.

Systems where adjustable frequency drives are installed must, if necessary, be equipped with additional monitoring and protective devices according to the valid safety regulations, e.g., law on mechanical tools, regulations for the prevention of accidents, etc. Modifying the adjustable frequency drives with the operating software is allowed.

NOTICE!

Hazardous situations shall be identified by the machine builder/integrator who is responsible for taking necessary preventive means into consideration. Additional monitoring and protective devices may be included, always according to valid national safety regulations, e.g., law on mechanical tools, regulations for the prevention of accidents.

Protection Mode

Once a hardware limit on motor current or DC link voltage is exceeded, the adjustable frequency drive will enter "Protection mode". "Protection mode" is a change of the PWM modulation strategy and a low switching frequency to minimize losses. This continues 10 s after the last fault and increases the reliability and the robustness of the adjustable frequency drive while re-establishing full control of the motor.

1.1.5 Electrical Wiring - Control Cables

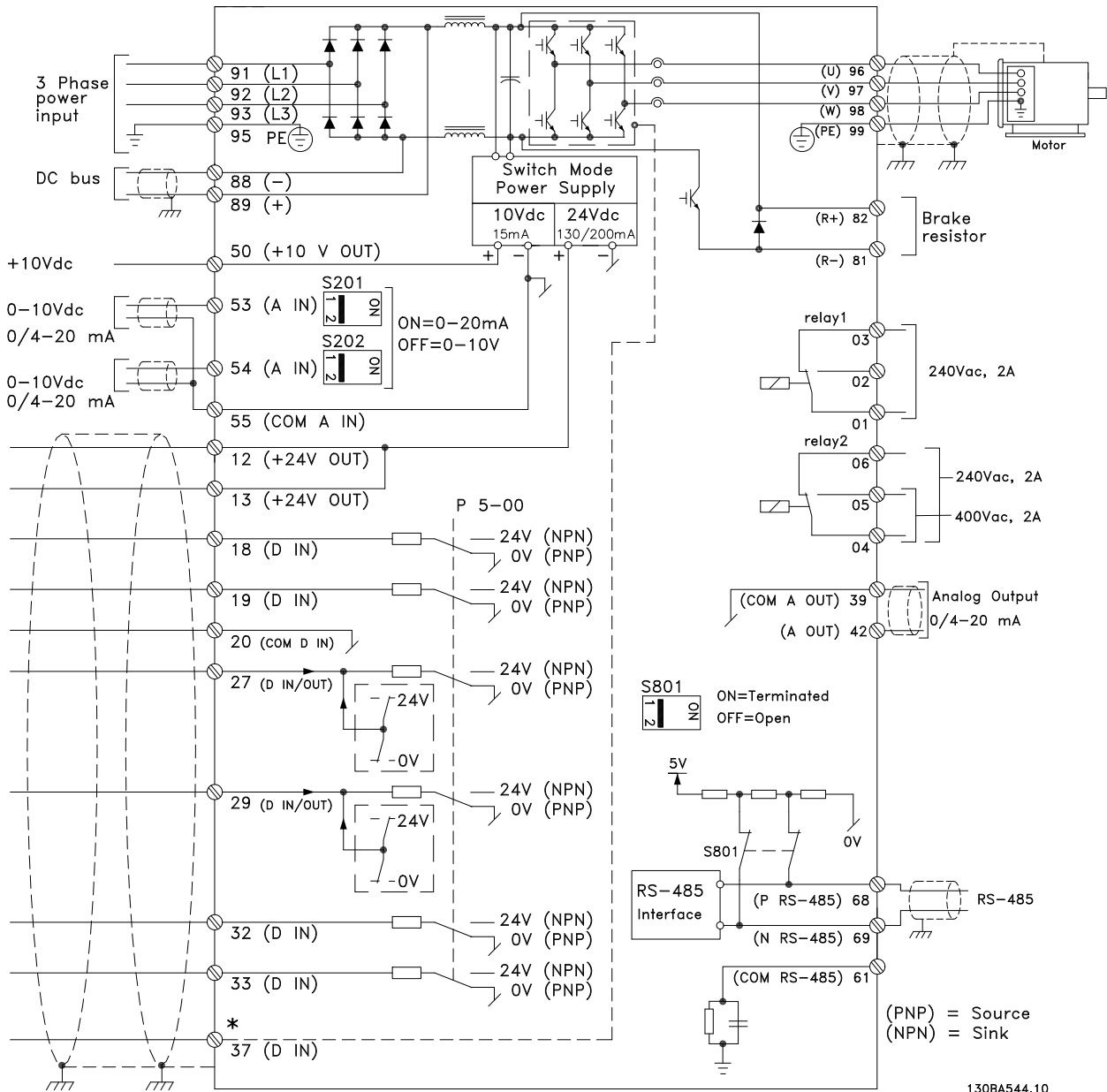

Figure 1.2 Diagram showing all electrical terminals without options.

Terminal 37 is the input to be used for Safe Stop. For instructions on Safe Stop installation, please refer to the section *Safe Stop Installation* of the Design Guide.

In rare cases, and depending on the installation, very long control cables and analog signals may result in 50/60 Hz ground loops due to noise from line power supply cables.

If this occurs, it may be necessary to break the shield or insert a 100 nF capacitor between shield and chassis.

The digital and analog inputs and outputs must be connected separately to the common inputs (terminal 20, 55, 39) of the adjustable frequency drive to avoid ground currents from both groups affecting other groups. For example, switching on the digital input may disturb the analog input signal.

Input polarity of control terminals

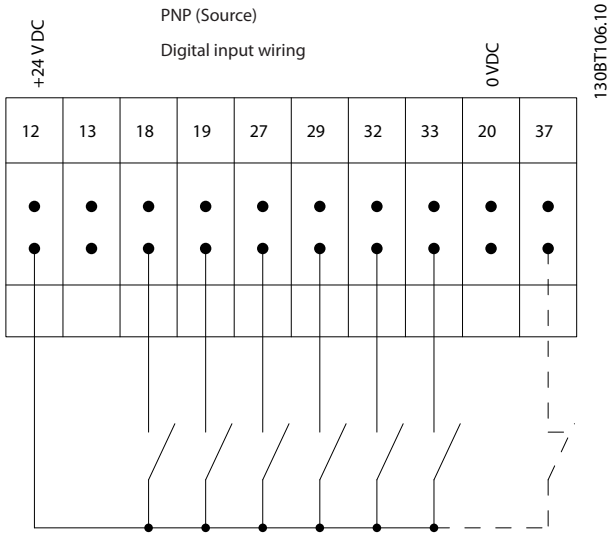

Figure 1.3

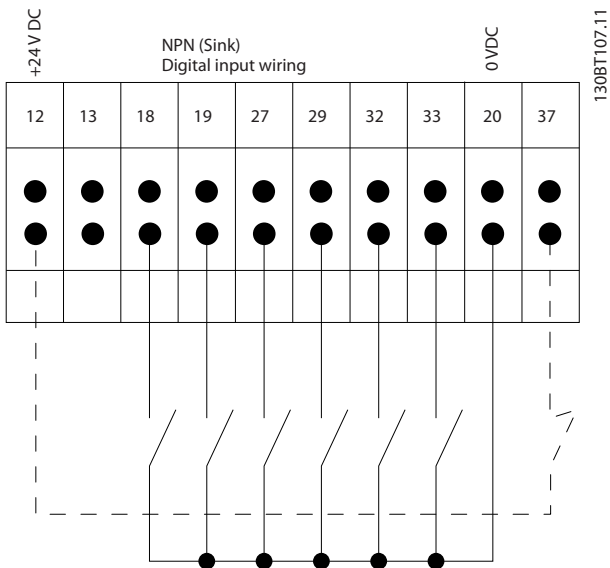

Figure 1.4

NOTICE!

Control cables must be shielded/armored.

See section on grounding of shielded/armored control cables in the *VLT® AQUA Drive Design Guide, MG20N* for the correct termination of control cables.

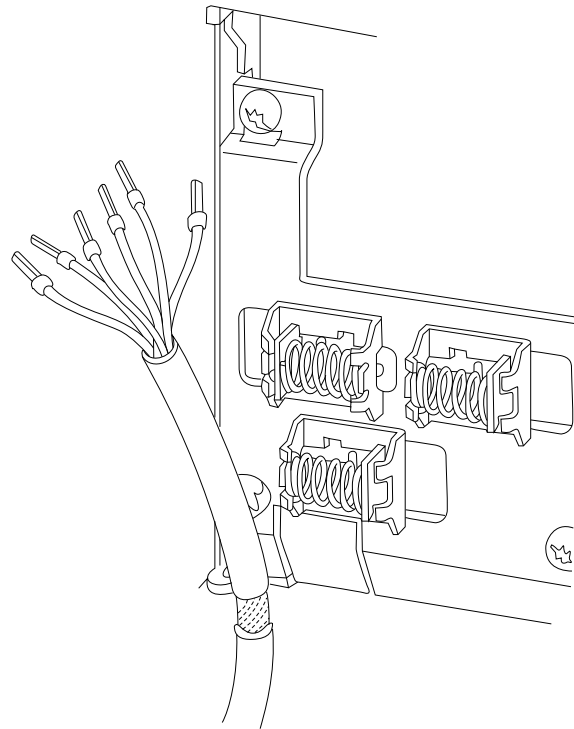

Figure 1.5

1.1.6 Start/Stop

Terminal 18 = 5-10 Terminal 18 Digital Input [8] Start
Terminal 27 = 5-12 Terminal 27 Digital Input [0] No operation (Default coast inverse)
Terminal 37 = Safe stop (where available)

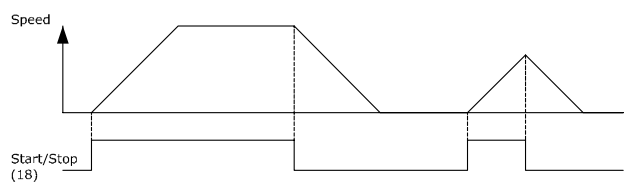
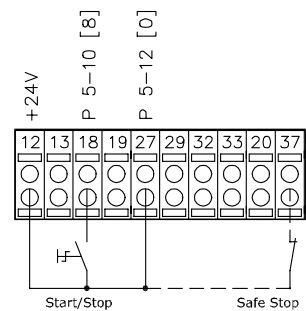

Figure 1.6

1.1.7 Pulse Start/Stop

Terminal 18 = 5-10 Terminal 18 Digital Input [9] Latched start

Terminal 27 = 5-12 Terminal 27 Digital Input [6] Stop inverse

Terminal 37 = Safe stop (where available)

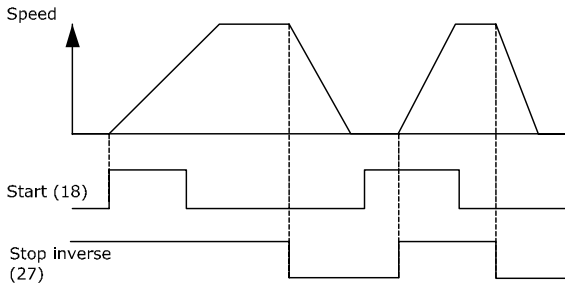
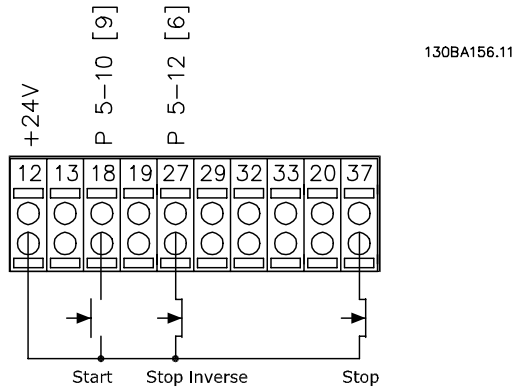

Figure 1.7

1.1.8 Speed Up/Down

Terminals 29/32 = Speed up/down

Terminal 18 = 5-10 Terminal 18 Digital Input [9] Start (default)

Terminal 27 = 5-12 Terminal 27 Digital Input [19] Freeze reference

Terminal 29 = 5-13 Terminal 29 Digital Input [21] Speed up

Terminal 32 = 5-14 Terminal 32 Digital Input [22] Slow

Terminal 29 only in FC x02 (x=series type).

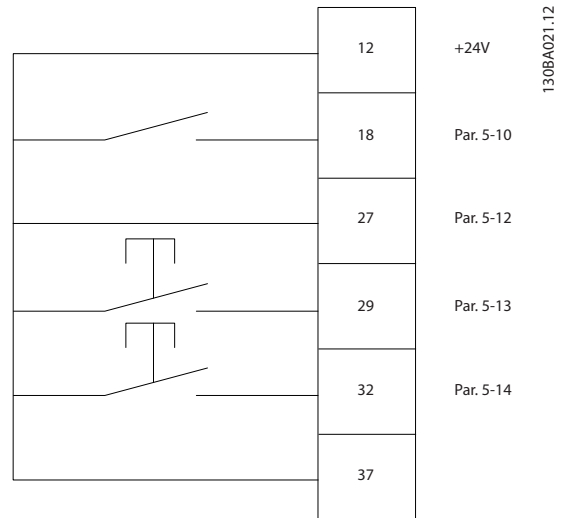

Figure 1.8

1.1.9 Potentiometer Reference

Voltage reference via a potentiometer

Reference Source 1 = [1] Analog input 53 (default)

Terminal 53, Low Voltage = 0 V

Terminal 53, High Voltage = 10 V

Terminal 53, Low Ref./Feedback = 0 RPM

Terminal 53, High Ref./Feedback = 1500 RPM

Switch S201 = OFF (U)

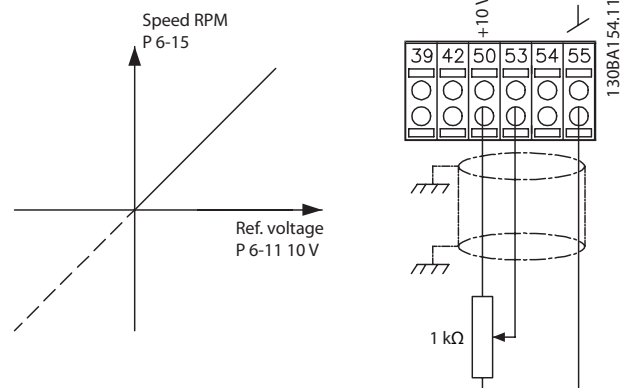

Figure 1.9

2 How to Program

2.1 The Graphical and Numerical Local Control Panel

The easiest programming of the adjustable frequency drive is performed by the Graphical LCP (LCP 102). It is necessary to consult the adjustable frequency drive Design Guide when using the Numeric Local Control Panel (LCP 101). For further information on how to use the Numeric Local Control Panel (LCP 101), see 2.3 *How to Program on the Numerical LCP*.

2.2 How to Program on the Graphical LCP

The control panel is divided into four functional groups

1. Graphical display with Status lines.
2. Menu keys and LEDs - changing parameters and switching between display functions.
3. Navigation keys and LEDs (LEDs).
4. Operation keys and LEDs.

All data is displayed in a graphical LCP display, which can show up to five items of operating data while displaying [Status].

Display lines

- a. **Status line:** Status messages displaying icons and graphic.
- b. **Line 1-2:** Operator data lines displaying data defined or chosen by the user. By pressing [Status], up to one extra line can be added.
- c. **Status line:** Status messages displaying text.

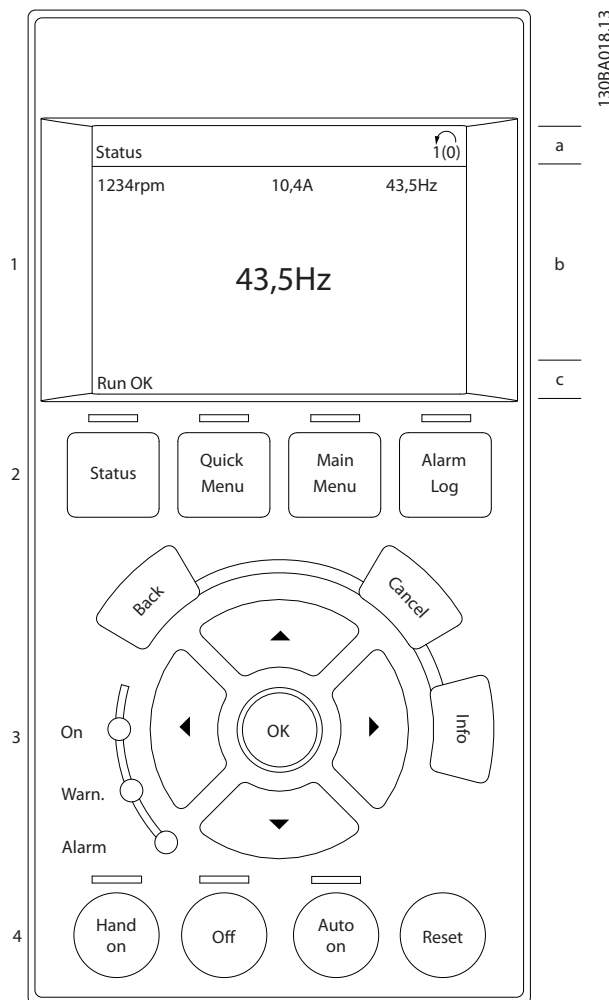

Figure 2.1

2

2.2.1 The LCP Display

The LCP display has back light and a total of 6 alpha-numeric lines. The display lines show the direction of rotation (arrow), the chosen set-up as well as the programming set-up. The display is divided into three sections.

Top section shows up to two measurements in normal operating status.

The top line in the **Middle section** shows up to five measurements with related unit, regardless of status (except in the case of alarm/warning).

Bottom section always shows the state of the adjustable frequency drive in status mode.

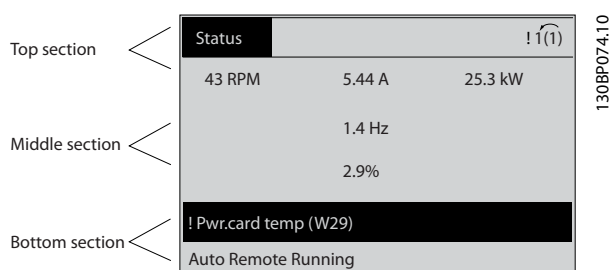

Figure 2.2

The Active set-up (selected as the Active Set-up in 0-10 Active Set-up) is shown. When programming another set-up than the Active Set-up, the number of the programmed set-up appears to the right.

Display Contrast Adjustment

Press [Status] and [▲] for darker display
 Press [Status] and [▼] for brighter display

Most parameter set-ups can be changed immediately via the LCP, unless a password has been created via 0-60 Main Menu Password or via 0-65 Personal Menu Password.

LEDs

If certain threshold values are exceeded, the alarm and/or warning LED lights up. A status and alarm text appear on the LCP.
 The ON LED is activated when the adjustable frequency drive receives line voltage, or via a DC bus terminal or 24 V external supply. At the same time, the backlight is on.

- Green LED/On: Control section is working.
- Yellow LED/Warn.: Indicates a warning.
- Flashing Red LED/Alarm: Indicates an alarm.

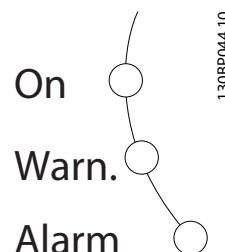

Figure 2.3
LCP Keys

The control keys are divided into functions. The keys below the display and LEDs are used for parameter set-up, including choice of display indication during normal operation:



Figure 2.4

[Status] indicates the status of the adjustable frequency drive and/or the motor. Choose between three different readouts by pressing [Status]: 5 line readouts, 4 line readouts or Smart Logic Control.

Press [Status] to select Display mode or for changing back to Display mode from either Quick Menu mode, Main Menu mode or Alarm mode. Also press [Status] to toggle single or double readout mode.

[Quick Menu]

Allows quick set-up of the adjustable frequency drive. **The most common functions can be programmed here.**

The [Quick Menu] consists of:

- Q1: My Personal Menu
- Q2: Quick Setup
- Q3: Function Set-ups
- Q5: Changes Made
- Q6: Loggings

The Function Set-up provides quick and easy access to all parameters required for the majority of water and wastewater applications including variable torque, constant torque pumps, dosing pumps, well pumps, booster pumps, mixer pumps, aeration blowers and other pump and fan applications. Amongst other features, it also includes parameters for selecting which variables to display on the LCP, digital preset speeds, scaling of analog references, closed-loop single zone and multi-zone applications and specific functions related to water and wastewater applications.

The Quick Menu parameters can be accessed immediately unless a password has been created via *0-60 Main Menu Password*, *0-61 Access to Main Menu w/o Password*, *0-65 Personal Menu Password* or *0-66 Access to Personal Menu w/o Password*.

It is possible to switch directly between Quick Menu mode and Main Menu mode.

[Main Menu]

is used for programming all parameters.

The Main Menu parameters can be accessed immediately unless a password has been created via *0-60 Main Menu Password*, *0-61 Access to Main Menu w/o Password*, *0-65 Personal Menu Password* or *0-66 Access to Personal Menu w/o Password*. For the majority of water and wastewater applications it is not necessary to access the Main Menu parameters. The Quick Menu, Quick Setup and Function Set-ups provide the simplest and quickest access to the typical required parameters.

It is possible to switch directly between Main Menu mode and Quick Menu mode.

Parameter shortcut can be carried out by pressing down [Main Menu] for 3 s. The parameter shortcut allows direct access to any parameter.

[Alarm Log]

displays an alarm list of the five latest alarms (numbered A1-A5). To obtain additional details about an alarm, use the navigation keys to navigate to the alarm number and press [OK]. Right before entering the alarm mode information about the condition of the adjustable frequency drive is provided.

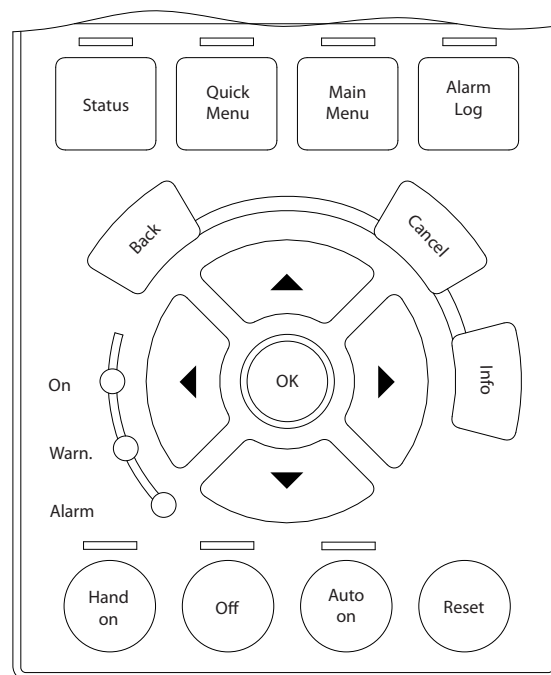

Figure 2.5

[Back] goes to the previous step or layer in the navigation structure.

[Cancel] annuls the latest change or command as long as the display has not been changed.

[Info] supplies information about a command, parameter, or function in any display window. [Info] provides detailed information whenever help is needed. Exit info mode by pressing either [Info], [Back], or [Cancel].

Navigation Keys

The four navigation keys are used to navigate between the different choices available in **[Quick Menu]**, **[Main Menu]** and **[Alarm Log]**. Use the keys to move the cursor.

[OK] is used for choosing a parameter marked by the cursor and for enabling the change of a parameter.

Local Control Key for local control are found at the bottom of the LCP.

[Hand On] enables control of the adjustable frequency drive via the LCP. [Hand on] also starts the motor, and it is now possible to enter the motor speed data using the navigation keys. The key can be selected as Enable [1] or Disable [0] via *0-40 [Hand on] Key on LCP*. External stop signals activated by means of control signals or a serial bus will override a "start" command via the LCP.

The following control signals will still be active when [Hand on] is activated

- [Hand On] - [Off] - [Auto On]
- Reset
- Coasting stop inverse
- Reversing
- Set-up select bit 0 - Set-up select bit 1
- Stop command from serial communication
- DC brake

[Off] stops the connected motor. The key can be selected as [1] Enable or [0] Disable via 0-41 [Off] Key on LCP. If no external stop function is selected and the [Off] key is inactive the motor can only be stopped by disconnecting the voltage.

[Auto On] enables the adjustable frequency drive to be controlled via the control terminals and/or serial communication. When a start signal is applied on the control terminals and/or the bus, the adjustable frequency drive will start. The key can be selected as [1] Enable or [0] Disable via 0-42 [Auto on] Key on LCP.

NOTICE!

An active HAND-OFF-AUTO signal via the digital inputs has higher priority than the control keys [Hand on] – [Auto on].

[Reset] is used for resetting the adjustable frequency drive after an alarm (trip). It can be selected as [1] Enable or [0] Disable via 0-43 [Reset] Key on LCP.

The parameter shortcut can be carried out by holding down the [Main Menu] key for three seconds. The parameter shortcut allows direct access to any parameter.

2.2.2 Quick Transfer of Parameter Settings between Multiple Adjustable Frequency Drives

Once the set-up of an adjustable frequency drive is complete, store the data in the LCP or on a PC via MCT 10 Set-up Software Tool.

Data storage in LCP

1. Go to 0-50 LCP Copy
2. Press [OK]
3. Select "All to LCP"
4. Press [OK]

All the parameter settings are now being stored in the LCP as indicated by the progress bar. When 100% is reached, press [OK].

NOTICE!

Stop the motor before performing this operation.

Connect the LCP to another adjustable frequency drive and copy the parameter settings to this adjustable frequency drive as well.

Data transfer from LCP to adjustable frequency drive

1. Go to 0-50 LCP Copy
2. Press [OK]
3. Select "All from LCP".
4. Press [OK]

The parameter settings stored in the LCP are now transferred to the adjustable frequency drive as indicated by the progress bar. When 100% is reached, press [OK].

NOTICE!

Stop the motor before performing this operation.

2.2.3 Display Mode

In normal operation, up to 5 different operating variables can be indicated continuously in the middle section: 1.1, 1.2, and 1.3 as well as 2 and 3.

2.2.4 Display Mode - Selection of Readouts

It is possible to toggle between three status readout screens by pressing [Status]. Operating variables with different formatting are shown in each status screen - see examples below.

Several values or measurements can be linked to each of the displayed operating variables. The values/measurements to be displayed can be defined via 0-20 Display Line 1.1 Small, 0-21 Display Line 1.2 Small, 0-22 Display Line 1.3 Small, 0-23 Display Line 2 Large, and 0-24 Display Line 3 Large, which can be accessed via [QUICK MENU], "Q3 Function Set-ups", "Q3-1 General Settings", "Q3-13 Display Settings".

Each readout parameter selected in 0-20 Display Line 1.1 Small to 0-24 Display Line 3 Large has its own scale and digits after a possible decimal point. The larger the numeric value for a parameter, the fewer digits displayed after the decimal point.

Ex.: Current readout 5.25 A; 15.2A 105A.

See parameter group 0-2* LCP Display for further details.

Status screen I

This readout state is standard after start-up or initialization. Press [Info] to obtain information about the measurement links to the displayed operating variables (1.1, 1.2, 1.3, 2 and 3). See the operating variables shown in the screen below.

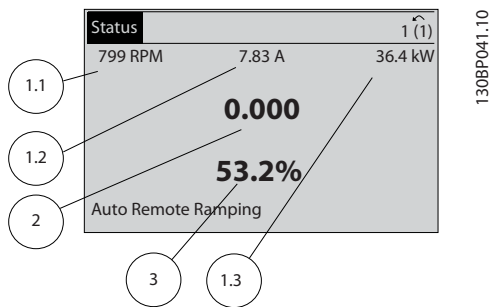

Figure 2.6

Status screen II

See the operating variables (1.1, 1.2, 1.3 and 2) shown in the screen below. In the example, Speed, Motor current, Motor power and Frequency are selected as variables in the first and second.

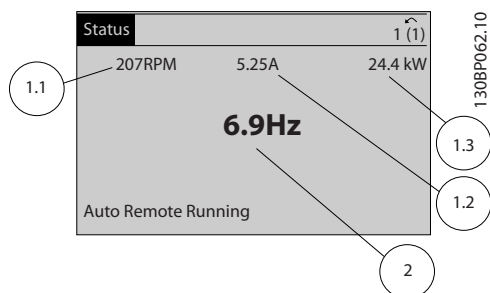

Figure 2.7

Status screen III

This state displays the event and action of the Smart Logic Control. For further information, see 3.12 Parameters 13-** Smart Logic Control.

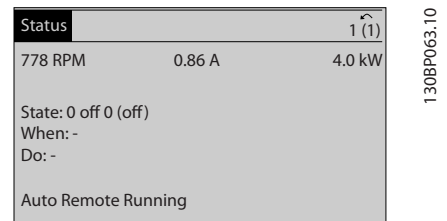

Figure 2.8

2.2.5 Parameter Set-Up, General Information

The adjustable frequency drive can be used for practically all assignments, which is why the number of parameters is quite large. The adjustable frequency drive offers a choice between two programming modes - a Main Menu and a Quick Menu mode.

The former provides access to all parameters. The latter takes the user through a few parameters making it possible to program the majority of water/waste water applications.

Regardless of the mode of programming, parameter can be changes in both Main Menu mode and in Quick Menu mode.

2.2.6 Quick Menu Key Functions

Pressing [Quick Menus]

The list indicates the different areas contained in the Quick menu.



130BP064.11

Figure 2.9

2

Select *My Personal Menu* to display the chosen personal parameters. These parameters are selected in *0-25 My Personal Menu*. Up to 20 different parameters can be added in this menu.

Select *Quick Set-up* to go through a limited amount of parameters to get the motor running almost optimally. The default setting for the other parameters considers the desired control functions and the configuration of signal inputs/outputs (control terminals).

Parameters are selected by using the arrow keys. The parameters in *Table 2.1* are accessible in the Quick Set-up.

Parameter	Unit
0-01 Language	
1-20 Motor Power [kW]	[kW]
1-22 Motor Voltage	[V]
1-23 Motor Frequency	[Hz]
1-24 Motor Current	[A]
1-25 Motor Nominal Speed	[rpm]
3-41 Ramp 1 Ramp-up Time	[sec]
3-42 Ramp 1 Ramp-down Time	[sec]
1-29 Automatic Motor Adaptation (AMA)	[1] Enable complete AMA

Table 2.1 Parameters in Quick Set-up

Select *Changes made* to get information about:

- the last 10 changes. Use the [▲] [▼] keys to scroll between the last ten changed parameters.
- the changes made since default setting.
- input assignments

Select *Loggings* to get information about the display line readouts. The information is shown as graphs. It is possible to store up to 120 samples in the memory for later reference.

2.2.7 Quick Menu, Q3 Function Set-ups

The Function Set-up provides quick and easy access to all parameters required for the majority of water and waste water applications including variable torque, constant torque, pumps, dosing pumps, well pumps, booster pumps, mixer pumps, aeration blowers and other pump and fan applications. Among other features, it also includes parameters for selecting which variables to display on the LCP, digital preset speeds, scaling of analog references, closed-loop single zone and multi-zone applications and specific functions related to water and waste water applications.

The Function Set-up parameters are grouped in the following way:

Q3-1 General Settings			
Q3-10 Clock Settings	Q3-11 Display Settings	Q3-12 Analog Output	Q3-13 Relays
0-70 Set Date and Time	0-20 Display Line 1.1 Small	6-50 Terminal 42 Output	Relay 1 ⇒ 5-40 Function Relay
0-71 Date Format	0-21 Display Line 1.2 Small	6-51 Terminal 42 Output Min Scale	Relay 2 ⇒ 5-40 Function Relay
0-72 Time Format	0-22 Display Line 1.3 Small	6-52 Terminal 42 Output Max Scale	Option relay 7 ⇒ 5-40 Function Relay
0-74 DST/Summertime	0-23 Display Line 2 Large		Option relay 8 ⇒ 5-40 Function Relay
0-76 DST/Summertime Start	0-24 Display Line 3 Large		Option relay 9 ⇒ 5-40 Function Relay
0-77 DST/Summertime End	0-37 Display Text 1		
	0-38 Display Text 2		
	0-39 Display Text 3		

Table 2.2

Q3-2 Open-loop Settings	
Q3-20 Digital Reference	Q3-21 Analog Reference
3-02 Minimum Reference	3-02 Minimum Reference
3-03 Maximum Reference	3-03 Maximum Reference
3-10 Preset Reference	6-10 Terminal 53 Low Voltage
5-13 Terminal 29 Digital Input	6-11 Terminal 53 High Voltage
5-14 Terminal 32 Digital Input	6-14 Terminal 53 Low Ref/Feedb. Value
5-15 Terminal 33 Digital Input	6-15 Terminal 53 High Ref/Feedb. Value

Table 2.3

Q3-3 Closed-loop Settings	
Q3-30 Feedback Settings	Q3-31 PID Settings
1-00 Configuration Mode	20-81 PID Normal/Inverse Control
20-12 Reference/Feedb.Unit	20-82 PID Start Speed [RPM]
3-02 Minimum Reference	20-21 Setpoint 1
3-03 Maximum Reference	20-93 PID Proportional Gain
6-20 Terminal 54 Low Voltage	20-94 PID Integral Time
6-21 Terminal 54 High Voltage	
6-24 Terminal 54 Low Ref/Feedb Value	
6-25 Terminal 54 High Ref/Feedb Value	
6-00 Live Zero Timeout Time	
6-01 Live Zero Timeout Function	

Table 2.4

2.2.8 Main Menu Mode

Start Main Menu mode by pressing [Main Menu]. The readout shown below appears on the display. The middle and bottom sections on the display show a list of parameter groups which can be chosen by toggling [▲] and [▼] keys.

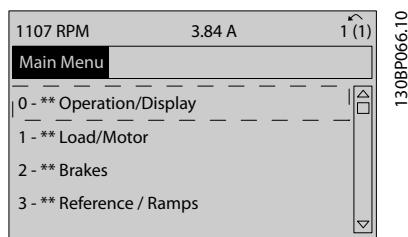

Figure 2.10

Each parameter has a name and number which remain the same regardless of the programming mode. In main menu mode, the parameters are divided into groups. The first digit of the parameter number (from the left) indicates the parameter group number.

All parameters can be changed in the Main Menu. However, depending on the choice of configuration (1-00 Configuration Mode), some parameters can be "missing". For example, open-loop hides all the PID parameters, and other enabled options make more parameter groups visible.

2.2.9 Parameter Selection

In Main menu mode, the parameters are divided into groups. Select a parameter group with the navigation keys. The following parameter groups are accessible:

Group #	Parameter group
0-**	Operation/Display
1-**	Load/Motor
2-**	Brakes
3-**	References/Ramps
4-**	Limits/Warnings
5-**	Digital In/Out
6-**	Analog In/Out
7-**	Controls
8-**	Comm. and Options
9-**	Profibus
10-**	CAN Ser. Com. Bus
11-**	Reserved Com. 1
12-**	Reserved Com. 2

Group #	Parameter group
13-**	Smart Logic
14-**	Special Functions
15-**	Drive Information
16-**	Data Readouts
17-**	Motor Feedb. Option
18-**	Data Readouts 2
30-**	Special Features
32-**	MCO Basic Settings
33-**	MCO Adv. Settings
34-**	MCO Data Readouts

Table 2.5

After selecting a parameter group, choose a parameter by means of the navigation keys. The middle section on the display shows the parameter number and name as well as the selected parameter value.

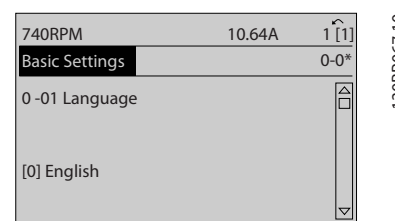

Figure 2.11

2.2.10 Changing Data

The procedure for changing data is the same in the Quick menu and Main Menu mode. Press [OK] to change the selected parameter.

The procedure for changing data depends on whether the selected parameter represents a numerical data value or a text value.

2.2.11 Changing a Text Value

If the selected parameter is a text value, change the text value with the [▲] [▼] keys. Place the cursor on the value to save and press [OK].

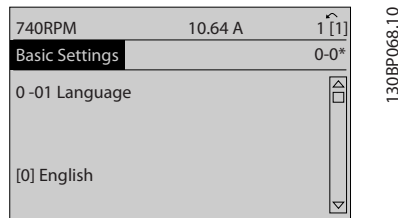

Figure 2.12

2.2.12 Changing a Group of Numeric Data Values

If the chosen parameter represents a numeric data value, change the chosen data value by means of the [◀] [▶] navigation keys as well as the [▲] [▼] navigation keys. Press [◀] [▶] keys to move the cursor horizontally.

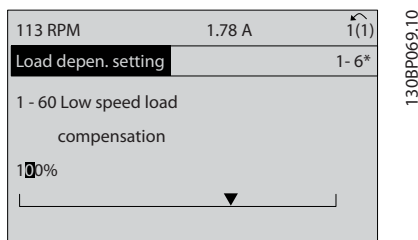

Figure 2.13

Press [▲] [▼] keys to change the data value. [▲] increases the data value, and [▼] decreases the data value. Place the cursor on the value to save and press [OK].

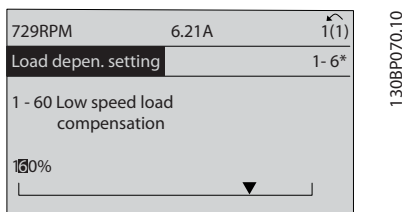

Figure 2.14

2.2.13 Infinitely Variable Change of Numeric Data Value

If the chosen parameter represents a numeric data value, select a digit with [◀] [▶].

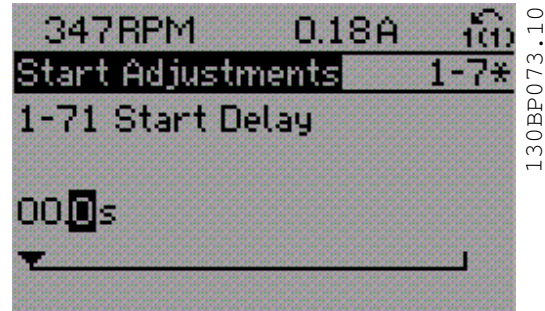

Figure 2.15

Change the selected digit infinitely variably with [▲] [▼]. The chosen digit is indicated by the cursor. Place the cursor on the digit to save and press [OK].

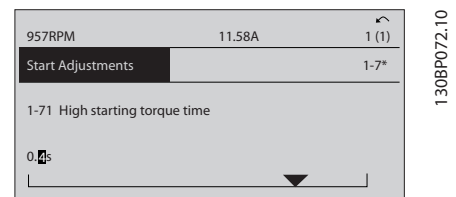

Figure 2.16

2.2.14 Value, Step-by-Step

Certain parameters can be changed step by step or infinitely varying. This applies to 1-20 Motor Power [kW], 1-22 Motor Voltage and 1-23 Motor Frequency. The parameters are changed both as a group of numeric data values and as numeric data values infinitely varying.

2.2.15 Readout and Programming of Indexed Parameters

Parameters are indexed when placed in a rolling stack. 15-30 Alarm Log: Error Code to 15-32 Alarm Log: Time contain a fault log which can be read out. Choose a parameter, press [OK], and use [▲] [▼] to scroll through the value log.

Use 3-10 Preset Reference as another example: Choose the parameter, press [OK], and use [▲] [▼] to scroll through the indexed values. To change the parameter value, select the indexed value and press [OK]. Change the value by pressing [▲] [▼]. Press [OK] to accept the new setting. Press [Cancel] to abort. Press [Back] to leave the parameter.

2.3 How to Program on the Numerical LCP

The following instructions are valid for the Numerical LCP (LCP 101).

The control panel is divided into four functional groups:

1. Numerical display.
2. Menu keys and LEDs - changing parameters and switching between display functions.
3. Navigation keys and LEDs (LEDs).
4. Operation keys and LEDs.

Display line: Status messages displaying icons and numeric value.

Indicator lights (LEDs)

- Green LED/On: Indicates if control section is on.
- Yellow LED/Wrn.: Indicates a warning.
- Flashing red LED/Alarm: Indicates an alarm.

LCP keys

[Menu] Select one of the following modes:

- Status
- Quick Set-up
- Main Menu

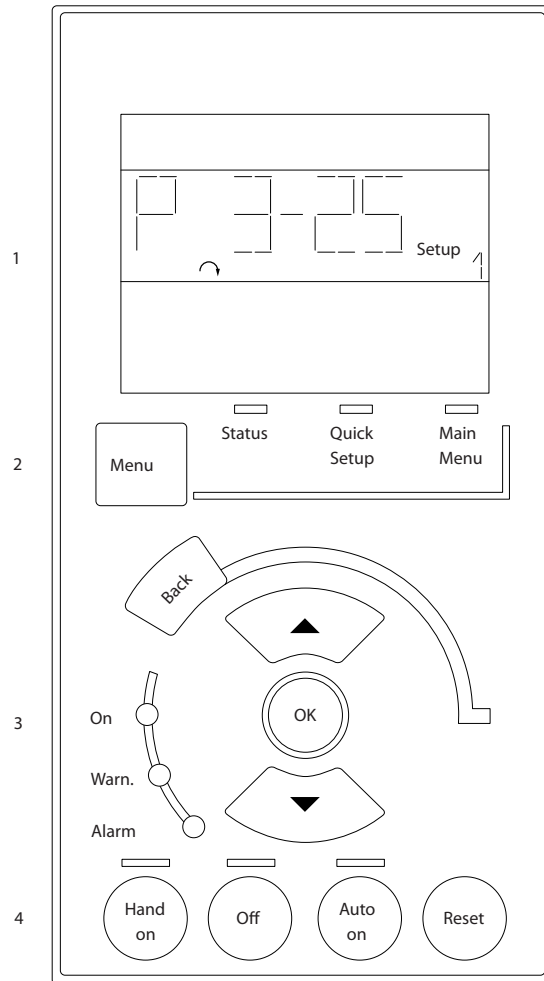

Figure 2.17

Status Mode

Displays the status of the adjustable frequency drive or the motor.

If an alarm occurs, the NLCP automatically switches to status mode.

A number of alarms can be displayed.

NOTICE!

Parameter copy is not possible with LCP 101 Numerical Local Control Panel.

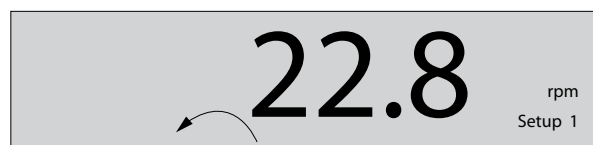

Figure 2.18



Figure 2.19

Main Menu/Quick Set-up is used for programming all parameters or only the parameters in the Quick Menu (see also description of the LCP 102 earlier in 2.3 *How to Program on the Numerical LCP*).

The parameter values can be changed by pressing [▲] or [▼] when the value is flashing.

Select Main Menu by pressing [Menu] a number of times.

Select the parameter group [xx-__] and press [OK]

Select the parameter [__-xx] and press [OK]

If the parameter is an array parameter, select the array number and press [OK]

Select the wanted data value and press [OK]

Parameters with functional choices display values such as [1], [2], etc. For a description of the different choices, see the individual description of the parameters in 3 *Parameter Description*

[Back] for stepping backwards

[▲] [▼] are used for navigating between commands and within parameters.

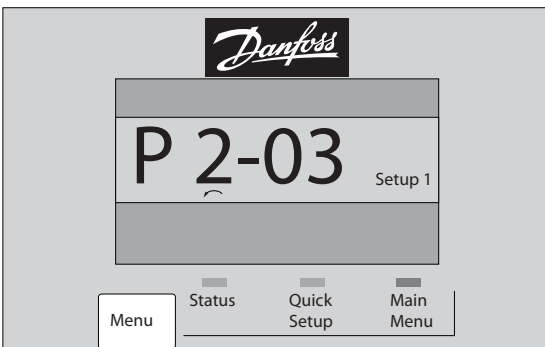

Figure 2.20

2.3.1 Local Control Keys

Keys for local control are found at the bottom of the LCP.

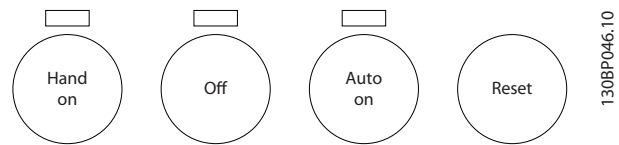

Figure 2.21

[Hand On] enables control of the adjustable frequency drive via the LCP. [Hand On] also starts the motor and it is now possible to enter the motor speed data using the arrow keys. The key can be selected as [1] *Enable* or [0] *Disable* via 0-40 [Hand on] Key on LCP.

External stop signals activated by means of control signals or a serial bus will override a “start” command via the LCP. The following control signals are still active when [Hand On] is activated:

- [Hand On] - [Off] - [Auto On]
- Reset
- Coasting stop inverse
- Reversing
- Set-up select lsb - Set-up select msb
- Stop command from serial communication
- Quick stop
- DC brake

[Off] stops the connected motor. The key can be selected as [1] *Enable* or [0] *Disable* via 0-41 [Off] Key on LCP.

If no external stop function is selected and the [Off] key is inactive, the motor can be stopped by disconnecting the voltage.

[Auto On] enables the adjustable frequency drive to be controlled via the control terminals and/or serial communication. When a start signal is applied on the control terminals and/or the bus, the adjustable frequency drive will start. The key can be selected as [1] *Enable* or [0] *Disable* via 0-42 [Auto on] Key on LCP.

NOTICE!

An active HAND-OFF-AUTO signal via the digital inputs has higher priority than the control keys [Hand On] [Auto On].

[Reset] is used for resetting the adjustable frequency drive after an alarm (trip). It can be selected as [1] *Enable* or [0] *Disable* via 0-43 [Reset] Key on LCP.

2.4 Initialization to Default Settings

Initialize the adjustable frequency drive to default settings in two ways.

Recommended initialization (via *14-22 Operation Mode*)

1. Select *14-22 Operation Mode*
2. Press [OK]
3. Select "Initialization"
4. Press [OK]
5. Cut off the line power supply and wait until the display turns off.
6. Reconnect the line power supply - the adjustable frequency drive is now reset.

14-22 Operation Mode initializes all except:

- 14-50 RFI 1
- 8-30 Protocol
- 8-31 Address
- 8-32 Baud Rate
- 8-35 Minimum Response Delay
- 8-36 Max Response Delay
- 8-37 Maximum Inter-Char Delay
- 15-00 Operating hours to *15-05 Over Volts*
- 15-20 Historic Log: Event to *15-22 Historic Log: Time*
- 15-30 Alarm Log: Error Code to *15-32 Alarm Log: Time*

Manual initialization

1. Disconnect from the line power and wait until the display turns off.
2.
 - 2a Press [Status] - [Main Menu] - [OK] at the same time while powering up for LCP 102, Graphical Display
 - 2b Press [Menu] while powering up for LCP 101, Numerical Display
3. Release the keys after 5 s.
4. The adjustable frequency drive is now programmed according to default settings.

This procedure initializes all except:

- 15-00 Operating hours*
- 15-03 Power-ups*
- 15-04 Over Temps*
- 15-05 Over Volts*

NOTICE!

A manual initialization also resets serial communication, RFI filter settings (*14-50 RFI 1*) and fault log settings.

3 Parameter Description

3.1 Parameter Selection

The parameters are grouped into various parameter groups for easy selection of the correct parameter for optimized adjustable frequency drive operation.

Overview of parameter groups

Group	Title	Function
0-**	Operation/Display	Parameters related to the fundamental functions of the adjustable frequency drive, function of the LCP keys and configuration of the LCP display.
1-**	Load/Motor	Parameter group for motor settings.
2-**	Brakes	Parameter group for setting brake features in the adjustable frequency drive.
3-**	Reference/Ramps	Parameters for reference handling, defining limitations, and configuring the reaction of the adjustable frequency drive to changes.
4-**	Limits/Warnings	Parameter group for configuring limits and warnings.
5-**	Digital In/Out	Parameter group for configuring the digital inputs and outputs.
6-**	Analog In/Out	Parameter group for configuring the analog inputs and outputs.
8-**	Communication and Options	Parameter group for configuring communications and options.
9-**	Profibus	Parameter group for Profibus-specific parameters (requires profibus option).
10-**	DeviceNet Ser ComBus	Parameter group for DeviceNet-specific parameters (requires DeviceNet option).
13-**	Smart Logic	Parameter group for Smart Logic Control
14-**	Special Functions	Parameter group for configuring special adjustable frequency drive functions.
15-**	Drive Information	Parameter group containing adjustable frequency drive information such as operating data, hardware configuration and software versions.
16-**	Data Readouts	Parameter group for data readouts, such as current references, voltages, control, alarm, warning and status words.
18-**	Info and Readouts	This parameter group contains the last 10 Preventive Maintenance logs.
20-**	Drive Closed-loop	This parameter group is used for configuring the closed-loop PID controller that controls the output frequency of the unit.
21-**	Extended Closed-loop	Parameters for configuring the three extended closed-loop PID controllers.
22-**	Application Functions	These parameters monitor water applications.
23-**	Time-based Functions	These parameters are for actions to be performed on a daily or weekly basis, such as different references for working hours/non-working hours.
24-**	Application Functions 2	Parameters for the Drive Bypass.
25-**	Basic Cascade Controller Functions	Parameters for configuring the Basic Cascade Controller for sequence control of multiple pumps.
26-**	Analog I/O Option MCB 109	Parameters for configuring the Analog I/O Option MCB 109.
27-**	Extended Cascade Control	Parameters for configuring the Extended Cascade Control (MCO 101/MCO 102).
29-**	Water Application Functions	Parameters for setting water specific functions.
30-**	Special Features	Parameters for configuring the brake resistor value.
31-**	Bypass Option	Parameters for configuring the Bypass Option (MCO 104).
35-**	Sensor Input Option	Parameters for configuring the Sensor Input Option (MCB 114)

Table 3.1 Parameter Groups

Parameter descriptions and selections are displayed on the graphic (GLCP) or numeric (NLCP) in the display area. (See 2 *How to Program* for details.) Access the parameters by pressing the [Quick Menu] or [Main Menu] key on the control panel. The quick menu is used primarily for commissioning the unit at start-up by providing those parameters necessary to start operation. The main menu provides access to all the parameters for detailed application programming.

All digital input/output and analog input/output terminals are multifunctional. All terminals have factory default functions suitable for the majority of water applications, but if other special functions are required, they must be programmed in parameter group 5-** or 6-**.

3.2 Parameters 0-** Operation and Display

Parameters related to the fundamental functions of the adjustable frequency drive, function of the LCP keys and configuration of the LCP display.

3.2.1 0-0* Basic Settings

0-01 Language		
Option:	Function:	
		Defines the language to be used in the display. The adjustable frequency drive can be delivered with two different language packages. English and German are included in both packages. English cannot be erased or manipulated.
[0]	English	Part of Language packages 1 - 2
[1]	Deutsch	Part of Language packages 1 - 2
[2]	Francais	Part of Language package 1
[3]	Dansk	Part of Language package 1
[4]	Spanish	Part of Language package 1
[5]	Italiano	Part of Language package 1
[6]	Svenska	Part of Language package 1
[7]	Nederlands	Part of Language package 1
[10]	Chinese	Language package 2
[20]	Suomi	Part of Language package 1
[22]	English US	Part of Language package 1
[27]	Greek	Part of Language package 1
[28]	Bras.port	Part of Language package 1
[36]	Slovenian	Part of Language package 1
[39]	Korean	Part of Language package 2

0-01 Language		
Option:	Function:	
[40]	Japanese	Part of Language package 2
[41]	Turkish	Part of Language package 1
[42]	Trad.Chinese	Part of Language package 2
[43]	Bulgarian	Part of Language package 1
[44]	Srpski	Part of Language package 1
[45]	Romanian	Part of Language package 1
[46]	Magyar	Part of Language package 1
[47]	Czech	Part of Language package 1
[48]	Polski	Part of Language package 1
[49]	Russian	Part of Language package 1
[50]	Thai	Part of Language package 2
[51]	Bahasa Indonesia	Part of Language package 2
[52]	Hrvatski	Part of Language package 2

0-02 Motor Speed Unit		
Option:	Function:	
		The display showing depends on settings in 0-02 <i>Motor Speed Unit</i> and 0-03 <i>Regional Settings</i> . The default setting of 0-02 <i>Motor Speed Unit</i> and 0-03 <i>Regional Settings</i> depends on which region of the world the adjustable frequency drive is supplied to, but can be re-programmed as required. NOTICE! Changing the <i>Motor Speed Unit</i> will reset certain parameters to their initial value. It is recommended to select the motor speed unit first before modifying other parameters.
[0]	RPM	Selects display of motor speed variables and parameters (i.e., references, feedback and limits) in terms of motor speed (RPM).
[1]	Hz	Selects display of motor speed variables and parameters (i.e., references, feedback and limits) in terms of output frequency to the motor (Hz).

NOTICE!

This parameter cannot be adjusted while the motor is running.

0-03 Regional Settings		
Option:	Function:	
		This parameter cannot be adjusted while the motor is running. The display showing depends on settings in <i>0-02 Motor Speed Unit</i> and <i>0-03 Regional Settings</i> . The default setting of <i>0-02 Motor Speed Unit</i> and <i>0-03 Regional Settings</i> depends on which region of the world the adjustable frequency drive is supplied to but can be re-programmed as required.
[0]	International	Sets <i>1-20 Motor Power [kW]</i> units to [kW] and the default value of <i>1-23 Motor Frequency</i> [50 Hz].
[1]	North America	Sets <i>1-21 Motor Power [HP]</i> units to HP and the default value of <i>1-23 Motor Frequency</i> to 60 Hz.

The settings not used are made invisible.

0-04 Operating State at Power-up		
Option:	Function:	
		Select the operating mode upon reconnection of the adjustable frequency drive to AC line voltage after power-down when operating in Hand (local) mode.
[0]	Resume	Resumes operation of the adjustable frequency drive maintaining the same local reference and the same start/stop condition (applied by [Hand On]/[Off] on the LCP or Hand Start via a digital input as before the adjustable frequency drive was powered down.
[1]	Forced stop, ref=old	Uses [1] <i>Forced stop, ref=old</i> to stop the adjustable frequency drive but at the same time retain in memory the local speed reference prior to power-down. After AC line voltage is reconnected and after receiving a start command (pressing [Hand On] or Hand Start command via a digital input) the adjustable frequency drive restarts and operates at the retained speed reference.

0-05 Local Mode Unit		
Option:	Function:	
		Defines if the local reference unit should be displayed in terms of the motor shaft speed (in RPM/Hz) or as percent.
[0]	As Motor Speed Unit	
[1]	%	

3.2.2 0-1* Set-up Operations

Define and control the individual parameter set-ups. The adjustable frequency drive has four parameter set-ups that can be programmed independently of each other. This makes the adjustable frequency drive very flexible and able to meet the requirements of many different AQUA system control schemes, often saving on the costs of external control equipment. For example, these can be used to program the adjustable frequency drive to operate according to one control scheme in one set-up (e.g., daytime operation) and another control scheme in another set-up (e.g., night setback). Alternatively, they can be used by an AHU or packaged unit OEM to identically program all their factory-fitted adjustable frequency drives for different equipment models within a range to have the same parameters and then during production/commissioning simply select a specific set-up depending on which model within that range the adjustable frequency drive is installed on.

The active set-up (i.e., the set-up in which the adjustable frequency drive is currently operating) can be selected in *0-10 Active Set-up* and is displayed in the LCP. Using Multi set-up, it is possible to switch between set-ups with the adjustable frequency drive running or stopped, via digital input or serial communication commands (e.g., for night setback). If it is necessary to change set-ups during operation, ensure *0-12 This Set-up Linked to* is programmed as required. For the majority of AQUA applications, it will not be necessary to program *0-12 This Set-up Linked to* even if change of set-up during operation is required; however, for very complex applications, using the full flexibility of the multiple set-ups may be required. Using *0-11 Programming Set-up*, it is possible to edit parameters within any of the set-ups while continuing adjustable frequency drive operation in its Active Set-up which can be a different set-up to that being edited. Using *0-51 Set-up Copy*, it is possible to copy parameter settings between the set-ups to enable quicker commissioning if similar parameter settings are required in different set-ups.

0-10 Active Set-up		
Option:	Function:	
		Select the set-up in which the adjustable frequency drive is to operate. Use <i>0-51 Set-up Copy</i> to copy a set-up to one or all other set-ups. To avoid conflicting settings of the same parameter within two different set-ups, link the set-ups together using <i>0-12 This Set-up Linked to</i> . Stop the adjustable frequency drive before switching between set-ups, where parameters marked 'not changeable during operation' have different values. Parameters which are 'not changeable during operation' are marked FALSE in <i>4 Parameter Lists</i> .
[0]	Factory setup	Cannot be changed. It contains the Danfoss data set, and can be used as a data source when returning the other set-ups to a known state.
[1]	Set-up 1	<i>[1] Set-up 1 to [4] Set-up 4</i> are the four parameter set-ups within which all parameters can be programmed.
[2]	Set-up 2	
[3]	Set-up 3	
[4]	Set-up 4	
[9]	Multi setup	Is used for remote selection of set-ups using digital inputs and the serial communication port. This set-up uses the settings from <i>0-12 This Set-up Linked to</i> .

0-11 Programming Set-up		
Option:	Function:	
		Select the set-up to be edited (i.e., programmed) during operation: either the active set-up or one of the inactive set-ups. The set-up number to be edited is displayed in the LCP in parentheses.
[0]	Factory setup	Cannot be edited, but it is useful as a data source for returning the other set-ups to a known state.
[1]	Set-up 1	<i>[1] Set-up 1 to [4] Set-up 4</i> can be edited freely during operation, independently of the active set-up.
[2]	Set-up 2	
[3]	Set-up 3	
[4]	Set-up 4	
[9]	Active Set-up	(i.e., the set-up in which the adjustable frequency drive is operating) can also be edited during operation. Editing parameters in the chosen set-up would normally be done

0-11 Programming Set-up		
Option:	Function:	
		from the LCP, but it is also possible from any of the serial communication ports.

0-12 This Set-up Linked to

Option:	Function:	
---------	-----------	--

This parameter only needs to be programmed if changing set-ups is required while the motor is running. It ensures that parameters that are 'not changeable during operation' have the same setting in all relevant set-ups.

To enable conflict-free changes from one set-up to another while the adjustable frequency drive is running, link set-ups containing parameters that are not changeable during operation. The link will ensure the proper synchronization of the 'not changeable during operation' parameter values when moving from one set-up to another during operation. 'Not changeable during operation' parameters can be identified by the label FALSE in the parameter lists in *4 Parameter Lists*.

The *0-12 This Set-up Linked to* feature is used when Multi set-up in *0-10 Active Set-up* is selected. Multi set-up can be used to move from one set-up to another during operation (i.e., while the motor is running).

Example:

Use Multi set-up to shift from Set-up 1 to Set-up 2 while the motor is running. Program parameters in Set-up 1 first, then ensure that Set-up 1 and Set-up 2 are synchronized (or 'linked'). Synchronization can be performed in two ways:

1. Change the edit set-up to *[2] Set-up 2* in *0-11 Programming Set-up* and set *0-12 This Set-up Linked to* to *[1] Set-up 1*. This will start the linking (synchronizing) process.

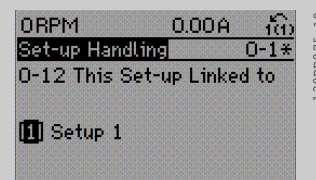



Figure 3.1

OR

2. While still in Set-up 1, using *0-50 LCP Copy*, copy Set-up 1 to Set-up 2. Then set *0-12 This Set-up Linked to* to *[2] Set-up 2*. This will start the linking process.

0-12 This Set-up Linked to	
Option:	Function:
	 <p>Figure 3.2</p> <p>After the link is complete, 0-13 Readout: Linked Set-ups will read {1,2} to indicate that all 'not changeable during operation' parameters are now the same in Set-up 1 and Set-up 2. If there are changes to a "not changeable during operation" parameter, e.g., 1-30 Stator Resistance (Rs) in Set-up 2, they will also be changed automatically in Set-up 1. A switch between Set-up 1 and Set-up 2 during operation is now possible.</p>
[0]	Not linked
[1]	Set-up 1
[2]	Set-up 2
[3]	Set-up 3
[4]	Set-up 4

0-13 Readout: Linked Set-ups													
Array [5]													
Range:	Function:												
0 * [0 - 255]	View a list of all the set-ups linked by means of 0-12 This Set-up Linked to. The parameter has one index for each parameter set-up. The parameter value displayed for each index represents which set-ups are linked to that parameter set-up.												
	<table border="1"> <thead> <tr> <th>Index</th> <th>LCP value</th> </tr> </thead> <tbody> <tr> <td>0</td> <td>{0}</td> </tr> <tr> <td>1</td> <td>{1,2}</td> </tr> <tr> <td>2</td> <td>{1,2}</td> </tr> <tr> <td>3</td> <td>{3}</td> </tr> <tr> <td>4</td> <td>{4}</td> </tr> </tbody> </table> <p>Table 3.3 Example: Set-up 1 and Set-up 2 are linked</p>	Index	LCP value	0	{0}	1	{1,2}	2	{1,2}	3	{3}	4	{4}
Index	LCP value												
0	{0}												
1	{1,2}												
2	{1,2}												
3	{3}												
4	{4}												

0-14 Readout: Prog. Set-ups / Channel	
Range:	Function:
0 * [-2147483648 - 2147483647]	View the setting of 0-11 Programming Set-up for each of the four different communication channels. When the number is displayed in hex, as it is in the LCP, each number represents one channel.

0-14 Readout: Prog. Set-ups / Channel	
Range:	Function:
	<p>Numbers 1-4 represent a set-up number; 'F' means factory setting; and 'A' means active set-up. The channels are, from right to left: LCP, FC bus, USB, HPFB1.5.</p> <p>Example: The number AAAAAA21h means that the FC bus selected Set-up 2 in 0-11 Programming Set-up, the LCP selected Set-up 1 and all others used the active set-up.</p>

3.2.3 0-2* LCP Display

Define the variables displayed in the Graphical Local Control Panel.

NOTICE!

Please refer to 0-37 Display Text 1, 0-38 Display Text 2 and 0-39 Display Text 3 for information on how to write display texts.

0-20 Display Line 1.1 Small		
Option:		Function:
		Select a variable for display in line 1, left position.
[0]	None	No display value selected
[37]	Display Text 1	Present control word
[38]	Display Text 2	Enables an individual text string to be written, for display in the LCP or to be read via serial communication.
[39]	Display Text 3	Enables an individual text string to be written, for display in the LCP or to be read via serial communication.
[89]	Date and Time Readout	Displays the current date and time.
[953]	Profibus Warning Word	Displays Profibus communication warnings.
[1005]	Readout Transmit Error Counter	View the number of CAN control transmission errors since the last power-up.
[1006]	Readout Receive Error Counter	View the number of CAN control receipt errors since the last power-up.
[1007]	Readout Bus Off Counter	View the number of Bus Off events since the last power-up.
[1013]	Warning Parameter	View a DeviceNet-specific warning word. One separate bit is assigned to every warning.

0-20 Display Line 1.1 Small		
Option:	Function:	
[1230]	Warning Parameter	
[1500]	Operating hours	View the number of running hours of the adjustable frequency drive.
[1501]	Running Hours	View the number of running hours of the motor.
[1502]	kWh Counter	View the line power consumption in kWh.
[1600]	Control Word	View the control word sent from the adjustable frequency drive via the serial communication port in hex code.
[1601]	Reference [Unit]	Total reference (sum of digital/analog/preset/bus/freeze ref./catch up and slow-down) in selected unit.
[1602]	Reference [%]	Total reference (sum of digital/analog/preset/bus/freeze ref./catch up and slow-down) in percent.
[1603]	Status Word	Present status word
[1605]	Main Actual Value [%]	One or more warnings in a Hex code
[1609]	Custom Readout	View the user-defined readouts as defined in <i>0-30 Custom Readout Unit</i> , <i>0-31 Custom Readout Min Value</i> and <i>0-32 Custom Readout Max Value</i> .
[1610]	Power [kW]	Actual power consumed by the motor in kW.
[1611]	Power [hp]	Actual power consumed by the motor in hp.
[1612]	Motor voltage	Voltage supplied to the motor.
[1613]	Frequency	Motor frequency, i.e., the output frequency from the adjustable frequency drive in Hz.
[1614]	Motor current	Phase current of the motor measured as effective value.
[1615]	Frequency [%]	Motor frequency, i.e., the output frequency from the adjustable frequency drive in percent.
[1616]	Torque [Nm]	Present motor load as a percentage of the rated motor torque.
[1617]	Speed [RPM]	Speed in RPM (revolutions per minute), i.e., the motor shaft speed in closed-loop based on the entered motor nameplate data, the output frequency and the load on the adjustable frequency drive.

0-20 Display Line 1.1 Small		
Option:	Function:	
[1618]	Motor Thermal	Thermal load on the motor, calculated by the ETR function. See also parameter group <i>1-9* Motor Temperature</i> .
[1622]	Torque [%]	Shows the actual torque produced, in percentage.
[1630]	DC Link Voltage	Intermediate circuit voltage in the adjustable frequency drive.
[1632]	Brake Energy /s	Present braking energy transferred to an external brake resistor. Stated as an instantaneous value.
[1633]	Brake Energy /2 min	Braking energy transferred to an external brake resistor. The mean power is calculated continuously for the most recent 120 seconds.
[1634]	Heatsink Temp.	Present heatsink temperature of the adjustable frequency drive. The cut-out limit is 203° F ± 9° F [95°±5°C]; cutting back in occurs at 158° F ±9° F [70°±5°C].
[1635]	Inverter Thermal	Percentage load of the inverters
[1636]	Inv. Nom. Current	Nominal current of the adjustable frequency drive.
[1637]	Inv. Max. Current	Maximum current of the adjustable frequency drive.
[1638]	SL Controller State	State of the event executed by the control
[1639]	Control Card Temp.	Temperature of the control card.
[1650]	External Reference	Sum of the external reference as a percentage, i.e. the sum of analog/pulse/bus.
[1652]	Feedback [Unit]	Signal value in units from the programmed digital input(s).
[1653]	Digi Pot Reference	View the contribution of the digital potentiometer to the actual reference Feedback.
[1654]	Feedback 1 [Unit]	View the value of Feedback 1. See also parameter group 20-0*.
[1655]	Feedback 2 [Unit]	View the value of Feedback 2. See also parameter group 20-0*.
[1656]	Feedback 3 [Unit]	View the value of Feedback 3. See also parameter group 20-0*.
[1658]	PID Output [%]	Returns the Drive Closed-loop PID controller output value in percent.

0-20 Display Line 1.1 Small		
Option:	Function:	
[1659]	Adjusted Setpoint	Displays the actual operating setpoint after it is modified by flow compensation. See parameter group 22-8*.
[1660]	Digital Input	Displays the status of the digital inputs. Signal low = 0; Signal high = 1. Regarding order, see <i>16-60 Digital Input</i> . Bit 0 is at the extreme right.
[1661]	Terminal 53 Switch Setting	Setting of input terminal 53. Current = 0; Voltage = 1.
[1662]	Analog Input 53	Actual value at input 53 either as a reference or protection value.
[1663]	Terminal 54 Switch Setting	Setting of input terminal 54. Current = 0; Voltage = 1.
[1664]	Analog Input 54	Actual value at input 54 either as reference or protection value.
[1665]	Analog Output 42 [mA]	Actual value at output 42 in mA. Use <i>6-50 Terminal 42 Output</i> to select the variable to be represented by output 42.
[1666]	Digital Output [bin]	Binary value of all digital outputs.
[1667]	Pulse Input #29 [Hz]	Actual value of the frequency applied at terminal 29 as a pulse input.
[1668]	Pulse Input #33 [Hz]	Actual value of the frequency applied at terminal 33 as a pulse input.
[1669]	Pulse Output #27 [Hz]	Actual value of pulses applied to terminal 27 in digital output mode.
[1670]	Pulse Output #29 [Hz]	Actual value of pulses applied to terminal 29 in digital output mode.
[1671]	Relay Output [bin]	View the setting of all relays.
[1672]	Counter A	View the present value of Counter A.
[1673]	Counter B	View the present value of Counter B.
[1675]	Analog In X30/11	Actual value of the signal on input X30/11 (General Purpose I/O Card. Option)
[1676]	Analog In X30/12	Actual value of the signal on input X30/12 (General Purpose I/O Card. Optional)
[1677]	Analog Out X30/8 [mA]	Actual value at output X30/8 (General Purpose I/O Card. Optional) Use <i>6-60 Terminal X30/8 Output</i> to select the variable to be shown.
[1680]	Fieldbus CTW 1	Control word (CTW) received from the bus master.

0-20 Display Line 1.1 Small		
Option:	Function:	
[1682]	Fieldbus REF 1	Main reference value sent with control word via the serial communications network, e.g. from the BMS, PLC or other master controller.
[1684]	Comm. Option Status	Extended serial communication bus option status word.
[1685]	FC Port CTW 1	Control word (CTW) received from the bus master.
[1686]	FC Port REF 1	Status word (STW) sent to the bus master.
[1690]	Alarm Word	One or more alarms in a Hex code (used for serial communications)
[1691]	Alarm Word 2	One or more alarms in a Hex code (used for serial communications)
[1692]	Warning Word	One or more warnings in a Hex code (used for serial communications)
[1693]	Warning Word 2	One or more warnings in a Hex code (used for serial communications)
[1694]	Ext. Status Word	One or more status conditions in a Hex code (used for serial communications)
[1695]	Ext. Status Word 2	One or more status conditions in a Hex code (used for serial communications)
[1696]	Maintenance Word	The bits reflect the status for the preventive maintenance events programmed in parameter group 23-1*
[1830]	Analog Input X42/1	Shows the value of the signal applied to terminal X42/1 on the Analog I/O card.
[1831]	Analog Input X42/3	Shows the value of the signal applied to terminal X42/3 on the Analog I/O card.
[1832]	Analog Input X42/5	Shows the value of the signal applied to terminal X42/5 on the Analog I/O card.
[1833]	Analog Out X42/7 [V]	Shows the value of the signal applied to terminal X42/7 on the Analog I/O card.
[1834]	Analog Out X42/9 [V]	Shows the value of the signal applied to terminal X42/9 on the Analog I/O card.
[1835]	Analog Out X42/11 [V]	Shows the value of the signal applied to terminal X42/11 on the Analog I/O card.

0-20 Display Line 1.1 Small		
Option:	Function:	
[1836]	Analog Input X48/2 [mA]	
[1837]	Temp. Input X48/4	
[1838]	Temp. Input X48/7	
[1839]	Temp. Input X48/10	
[1860]	Digital Input 2	
[2117]	Ext. 1 Reference [Unit]	The value of the reference for extended Closed-loop Controller 1
[2118]	Ext. 1 Feedback [Unit]	The value of the feedback signal for extended Closed-loop Controller 1
[2119]	Ext. 1 Output [%]	The value of the output from extended Closed-loop Controller 1
[2137]	Ext. 2 Reference [Unit]	The value of the reference for extended Closed-loop Controller 2
[2138]	Ext. 2 Feedback [Unit]	The value of the feedback signal for extended Closed-loop Controller 2
[2139]	Ext. 2 Output [%]	The value of the output from extended Closed-loop Controller 2
[2157]	Ext. 3 Reference [Unit]	The value of the reference for extended Closed-loop Controller 3
[2158]	Ext. 3 Feedback [Unit]	The value of the feedback signal for extended Closed-loop Controller 3
[2159]	Ext. 3 Output [%]	The value of the output from extended Closed-loop Controller 3
[2230]	No-Flow Power	The calculated No-Flow Power for the actual operating speed
[2316]	Maintenance Text	
[2580]	Cascade Status	Status for the operation of the cascade controller
[2581]	Pump Status	Status for the operation of each individual pump controlled by the cascade controller
[2791]	Cascade Reference	Reference output for use with follower drives.
[2792]	% Of Total Capacity	Readout parameter to show the system operating point as a % capacity of total system capacity.
[2793]	Cascade Option Status	Readout parameter to show the status of the cascade system.
[2794]	Cascade System Status	
[2795]	Advanced Cascade Relay Output [bin]	
[2796]	Extended Cascade Relay Output [bin]	

0-20 Display Line 1.1 Small		
Option:	Function:	
[2920]	Derag Power[kW]	
[2921]	Derag Power[HP]	
[3110]	Bypass Status Word	
[3111]	Bypass Running Hours	
[9920]	HS Temp. (PC1)	
[9921]	HS Temp. (PC2)	
[9922]	HS Temp. (PC3)	
[9923]	HS Temp. (PC4)	
[9924]	HS Temp. (PC5)	
[9925]	HS Temp. (PC6)	
[9926]	HS Temp. (PC7)	
[9927]	HS Temp. (PC8)	
[9951]	PC Debug 0	
[9952]	PC Debug 1	
[9953]	PC Debug 2	
[9954]	PC Debug 3	
[9955]	PC Debug 4	
[9956]	Fan 1 Feedback	
[9957]	Fan 2 Feedback	
[9958]	PC Auxiliary Temp	
[9959]	Power Card Temp.	

0-21 Display Line 1.2 Small

Option:	Function:	
		Select a variable for display in line 1, middle position.
[1601] *	Analog input 53	The options are the same as those listed for 0-20 Display Line 1.1 Small.

0-22 Display Line 1.3 Small

Option:	Function:	
		Select a variable for display in line 1, right position.
[1614] *	Motor Current	The options are the same as those listed for 0-20 Display Line 1.1 Small.

0-23 Display Line 2 Large

Option:	Function:	
		Select a variable for display in line 2.
[1613] *	Frequency	The options are the same as those listed for 0-20 Display Line 1.1 Small.

0-24 Display Line 3 Large

Option:	Function:	
[1652] *	Feedback [Unit]	The options are the same as those listed for 0-20 Display Line 1.1 Small.
		Select a variable for display in line 2.

0-25 My Personal Menu		
Array [20]		
Range:		Function:
Size related*	[0 - 9999]	Define up to 20 parameters to appear in the Q1 Personal Menu, accessible via the [Quick Menu] key on the LCP. The parameters will be displayed in the Q1 Personal Menu in the order they are programmed into this array parameter. Delete parameters by setting the value to '0000'. For example, this can be used to provide quick, simple access to just one or up to 50 parameters which require changing on a regular basis.

Unit Type	Speed Relation
Dimensionless	Linear
Speed	
Flow, volume	
Flow, mass	
Velocity	
Length	
Temperature	Quadratic
Pressure	
Power	Cubic

Table 3.4

3.2.4 0-3* LCP Custom Readout

It is possible to customize the display elements for various purposes: *Custom Readout. Value proportional to speed (linear, squared or cubed depending on unit selected in 0-30 Custom Readout Unit) *Display Text. Text string stored in a parameter.

Custom Readout

The calculated value to be displayed is based on settings in 0-30 Custom Readout Unit, 0-31 Custom Readout Min Value (linear only), 0-32 Custom Readout Max Value, 4-13 Motor Speed High Limit [RPM], 4-14 Motor Speed High Limit [Hz] and actual speed.

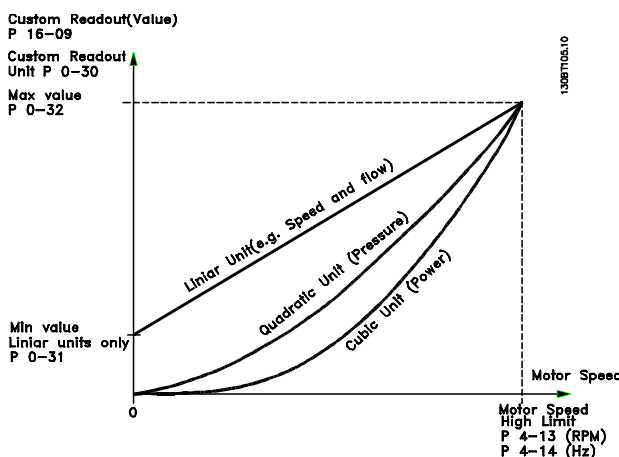

Figure 3.3

The relation will depend on the type of unit selected in 0-30 Custom Readout Unit:

0-30 Custom Readout Unit		
Option:	Function:	
		Program a value to be shown in the display of the LCP. The value has a linear, squared or cubed relation to speed. This relation depends on the unit selected (see Table 3.4). The actual calculated value can be read in 16-09 Custom Readout, and/or shown in the display by selecting [1609 Custom Readout] in 0-20 Display Line 1.1 Small to 0-24 Display Line 3 Large.
[0]	None	
[1]	%	
[5]	PPM	
[10]	min	
[11]	RPM	
[12]	PULSE/s	
[20]	liter / sec.	
[21]	liter / min	
[22]	liter / hr.	
[23]	m ³ / sec.	
[24]	m ³ /min	
[25]	m ³ / hr.	
[30]	kg / sec.	
[31]	kg/min	
[32]	kg / hr.	
[33]	ton / min	
[34]	ton / hr.	
[40]	m / sec.	
[41]	m/min	
[45]	m	
[60]	°C	
[70]	mbar	
[71]	bar	
[72]	Pa	
[73]	kPa	
[74]	m WG	
[75]	mm Hg	
[80]	kW	

0-30 Custom Readout Unit	
Option:	Function:
[120]	GPM
[121]	gal / sec.
[122]	gal/min
[123]	gal / hr.
[124]	CFM
[125]	ft ³ /s
[126]	ft ³ /min
[127]	ft ³ /h
[130]	lbs / sec.
[131]	lbs / min.
[132]	lbs / hr.
[140]	ft/s
[141]	ft/min
[145]	ft
[160]	°F
[170]	psi
[171]	lb/in ²
[172]	in. wtr. gage
[173]	ft WG
[174]	in Hg
[180]	HP

0-31 Custom Readout Min Value	
Range:	Function:
Size related* [0.00 - 100.00 CustomReadoutUnit]	This parameter allows the choice of the min. value of the custom defined readout (occurs at zero speed). It is only possible to select a value different to 0 when selecting a linear unit in <i>0-30 Custom Readout Unit</i> . For quadratic and cubic units, the minimum value will be 0.

0-32 Custom Readout Max Value	
Range:	Function:
100 CustomReadoutUnit*	[par. 0-31 - 999999.99 CustomReadoutUnit] This parameter sets the max value to be shown when the speed of the motor has reached the set value for <i>4-13 Motor Speed High Limit [RPM]</i> or <i>4-14 Motor Speed High Limit [Hz]</i> (depends on setting in <i>0-02 Motor Speed Unit</i>).

0-37 Display Text 1	
Range:	Function:
0 * [0 - 0]	In this parameter, it is possible to write an individual text string for display in the LCP or to be read via serial communication. If it is to be displayed permanently, select Display Text 1 in <i>0-20 Display Line 1.1 Small</i> , <i>0-21 Display Line 1.2 Small</i> , <i>0-22 Display Line 1.3 Small</i> , <i>0-23 Display Line 2 Large</i> or <i>0-24 Display Line 3 Large</i> . Press [▲] or [▼] to change a character. Press [◀] and [▶] to move the cursor. When a character is highlighted by the cursor, it can be changed. Press [▲] or [▼] to change a character. A character can be inserted by placing the cursor between two characters and pressing [▲] or [▼].

0-38 Display Text 2	
Range:	Function:
0 * [0 - 0]	In this parameter, it is possible to write an individual text string for display in the LCP or to be read via serial communication. If to be displayed permanently select Display Text 2 in <i>0-20 Display Line 1.1 Small</i> , <i>0-21 Display Line 1.2 Small</i> , <i>0-22 Display Line 1.3 Small</i> , <i>0-23 Display Line 2 Large</i> or <i>0-24 Display Line 3 Large</i> . Press [▲] or [▼] to change a character. Press [◀] and [▶] to move the cursor. When a character is highlighted by the cursor, this character can be changed. A character can be inserted by placing the cursor between two characters and pressing [▲] or [▼].

0-39 Display Text 3	
Range:	Function:
0 * [0 - 0]	In this parameter, it is possible to write an individual text string for display in the LCP or to be read via serial communication. If it is to be displayed permanently, select Display Text 3 in <i>0-20 Display Line 1.1 Small</i> , <i>0-21 Display Line 1.2 Small</i> , <i>0-22 Display Line 1.3 Small</i> , <i>0-23 Display Line 2 Large</i> or <i>0-24 Display Line 3 Large</i> . Press [▲] or [▼] to change a character. Press [◀] and [▶] to move the cursor. When a character is highlighted by the cursor, this character can be changed. A character can be inserted by placing the cursor between two characters and pressing [▲] or [▼].

3.2.5 0-4* LCP Keypad

Enable, disable and password protect individual keys on the LCP.

0-40 [Hand on] Key on LCP		
Option:	Function:	
[0] Disabled	Key disabled avoids accidental usage of the key.	
[1] Enabled	[Hand On] key enabled	
[2] Password	Avoid unauthorized start in hand mode. If 0-40 [Hand on] Key on LCP is included in the My Personal Menu, then define the password in 0-65 Personal Menu Password. Otherwise, define the password in 0-60 Main Menu Password.	

0-41 [Off] Key on LCP		
Option:	Function:	
[0] Disabled	Key disabled avoids accidental usage of the key.	
[1] Enabled	[Off] key is enabled	
[2] Password	Avoid unauthorized stop. If 0-41 [Off] Key on LCP is included in the My Personal Menu, then define the password in 0-65 Personal Menu Password. Otherwise, define the password in 0-60 Main Menu Password.	

0-42 [Auto on] Key on LCP		
Option:	Function:	
[0] Disabled	Key disabled avoids accidental usage of the key.	
[1] Enabled	[Auto On] key is enabled	
[2] Password	Avoid unauthorized start in auto mode. If 0-42 [Auto on] Key on LCP is included in the My Personal Menu, then define the password in 0-65 Personal Menu Password. Otherwise define the password in 0-60 Main Menu Password.	

0-43 [Reset] Key on LCP		
Option:	Function:	
[0] Disabled	Key disabled avoids accidental usage of the key.	
[1] Enabled	[Reset] key is enabled	
[2] Password	Avoid unauthorized resetting. If 0-43 [Reset] Key on LCP is included in the 0-25 My Personal Menu, then define the password in 0-65 Personal Menu Password. Otherwise, define the password in 0-60 Main Menu Password.	
[3] Enabled without OFF		
[4] Password w/out OFF		
[5] Enabled with OFF		

0-43 [Reset] Key on LCP		
Option:	Function:	
[6] Password with OFF		

0-44 [Off/Reset] Key on LCP		
Option:	Function:	
[0] Disabled	Key disabled avoids accidental usage of the key.	
[1] Enabled		
[2] Password		

0-45 [Drive Bypass] Key on LCP		
Option:	Function:	
[0] Disabled	Key disabled avoids accidental usage of the key.	
[1] Enabled		
[2] Password		

3.2.6 0-5* Copy/Save

Copy parameter settings between set-ups and to/from the LCP.

0-50 LCP Copy		
Option:	Function:	
[0] No copy	No function	
[1] All to LCP	Copies all parameters in all set-ups from the adjustable frequency drive memory to the LCP memory. For service purposes, copying all parameters to the LCP is recommended after commissioning.	
[2] All from LCP	Copies all parameters in all set-ups from the LCP memory to the adjustable frequency drive memory.	
[3] Size indep. of LCP	Copies only the parameters that are independent of the motor size. The latter selection can be used to program several adjustable frequency drives with the same function without disturbing motor data that are already set.	

This parameter cannot be adjusted while the motor is running.

0-51 Set-up Copy		
Option:	Function:	
[0]	No copy	No function
[1]	Copy to set-up 1	Copies all parameters in the present Programming Set-up (defined in 0-11 Programming Set-up) to Set-up 1.
[2]	Copy to set-up 2	Copies all parameters in the present Programming Set-up (defined in 0-11 Programming Set-up) to Set-up 2.
[3]	Copy to set-up 3	Copies all parameters in the present Programming Set-up (defined in 0-11 Programming Set-up) to Set-up 3.
[4]	Copy to set-up 4	Copies all parameters in the present Programming Set-up (defined in 0-11 Programming Set-up) to Set-up 4.
[9]	Copy to all	Copies the parameters in the present set-up over to each of the set-ups 1 to 4.

3.2.7 0-6* Password

0-60 Main Menu Password		
Range:	Function:	
100 *	[-9999 - 9999]	Define the password for access to the main menu via the [Main Menu] key. If 0-61 Access to Main Menu w/o Password is set to [0] Full access, this parameter will be ignored.

0-61 Access to Main Menu w/o Password		
Option:	Function:	
[0]	Full access	Disables password defined in 0-60 Main Menu Password.
[1]	LCP: Read only	Prevent unauthorized editing of main menu parameters.
[2]	LCP: No access	Prevent unauthorized viewing and editing of main menu parameters.
[3]	Bus: Read only	
[4]	Bus: No access	
[5]	All: Read only	
[6]	All: No access	

If [0] Full access is selected, then 0-60 Main Menu Password, 0-65 Personal Menu Password and 0-66 Access to Personal Menu w/o Password will be ignored.

0-65 Personal Menu Password		
Range:	Function:	
200 *	[-9999 - 9999]	Define the password for access to the My Personal Menu via the [Quick Menu] key. If 0-66 Access to Personal Menu w/o Password is set to [0] Full access, this parameter will be ignored.

0-66 Access to Personal Menu w/o Password		
Option:	Function:	
[0]	Full access	Disables password defined in 0-65 Personal Menu Password.
[1]	LCP: Read only	Prevents unauthorized editing of My Personal Menu parameters.
[2]	LCP: No access	Prevents unauthorized viewing and editing of My Personal Menu parameters.
[3]	Bus: Read only	
[4]	Bus: No access	
[5]	All: Read only	
[6]	All: No access	

If 0-61 Access to Main Menu w/o Password is set to [0] Full access, this parameter will be ignored.

0-67 Bus Password Access		
Range:	Function:	
0 *	[0 - 9999]	Writing to this parameter enables users to unlock the adjustable frequency drive from bus/MCT 10 Set-up Software.

3.2.8 0-7* Clock Settings

Set the time and date of the internal clock. The internal clock can be used, for example, for timed actions, energy log, trend analysis, date/time stamps on alarms, logged data and preventive maintenance.

It is possible to program the clock for Daylight Saving Time/summertime, weekly working days/non-working days including 20 exceptions (holidays, etc.). Although the clock settings can be set via the LCP, they can also be set along with timed actions and preventative maintenance functions using the MCT 10 Set-up Software software tool.

NOTICE!

The adjustable frequency drive has no backup of the clock function and the set date/time will reset to default (2000-01-01 00:00) after a power-down unless a real time clock module with backup is installed. If no module with backup is installed, it is recommended that the clock function only be used if the adjustable frequency drive is integrated into an external system using serial communications, with the system maintaining synchronization of control equipment clock times. In *0-79 Clock Fault*, it is possible to program a warning to be issued if the clock has not been set properly, e.g., after a power-down.

NOTICE!

When mounting an analog I/O MCB 109 option card, a battery backup of the date and time is included.

0-70 Date and Time		
Range:	Function:	
Size related*	[0 - 0]	Sets the date and time of the internal clock. The format to be used is set in <i>0-71 Date Format</i> and <i>0-72 Time Format</i> .

0-71 Date Format		
Option:	Function:	
[0]	YYYY-MM-DD	Sets the date format to be used in the LCP.
[1]	DD-MM-YYYY	Sets the date format to be used in the LCP.
[2]	MM/DD/YYYY	Sets the date format to be used in the LCP.

0-72 Time Format		
Option:	Function:	
		Sets the time format to be used in the LCP.
[0]	24 h	
[1]	12 h	

0-74 DST/Summertime		
Option:	Function:	
		Choose how Daylight Saving Time/Summertime should be handled. For manual DST/Summertime enter the start date and end date in <i>0-76 DST/Summertime Start</i> and <i>0-77 DST/Summertime End</i> .
[0]	OFF	
[2]	Manual	

0-76 DST/Summertime Start		
Range:	Function:	
Size related*	[0 - 0]	Sets the date and time when summertime/DST starts. The date is programmed in the format selected in <i>0-71 Date Format</i> .

0-77 DST/Summertime End		
Range:	Function:	
Size related*	[0 - 0]	Sets the date and time when summertime/DST ends. The date is programmed in the format selected in <i>0-71 Date Format</i> .

0-79 Clock Fault		
Option:	Function:	
		Enables or disables the clock warning when the clock has not been set, or has been reset due to a power-down and no backup is installed. If MCB 109 is installed "enabled" is default
[0]	Disabled	
[1]	Enabled	

0-81 Working Days		
Array with seven elements [0]–[6] displayed below parameter number in display. Press [OK] and step between elements using [▲] and [▼].		
Option:	Function:	
		Specify whether each weekday is a workday or a non-workday. First element of the array is Monday. The workdays are used for timed actions.
[0]	No	
[1]	Yes	

0-82 Additional Working Days		
Array with five elements [0]–[4] displayed below parameter number in display. Press [OK] and step between elements using [▲] and [▼].		
Range:	Function:	
Size related*	[0 - 0]	Defines dates for additional working days that normally would be non-working days according to <i>0-81 Working Days</i> .

0-83 Additional Non-Working Days		
Array with 15 elements [0]–[14] displayed below parameter number in display. Press [OK] and step between elements using [▲] and [▼].		
Range:	Function:	
Size related*	[0 - 0]	Defines dates for additional working days that normally would be non-working days according to <i>0-81 Working Days</i> .

3

0-89 Date and Time Readout		
Range:		Function:
0 *	[0 - 0]	Displays the current date and time. The date and time is updated continuously. The clock will not begin counting until a setting different from default has been made in <i>0-70 Date and Time</i> .

3.3 Parameters 1-** Load and Motor

3.3.1 1-0* General Settings

Define whether the adjustable frequency drive operates in open-loop or closed-loop.

1-00 Configuration Mode		
Option:	Function:	
[0]	Open-loop	Motor speed is determined by applying a speed reference or by setting desired speed when in Hand mode. Open-loop is also used if the adjustable frequency drive is part of a closed-loop control system based on an external PID controller providing a speed reference signal as output.
[3]	Closed-loop	Motor Speed will be determined by a reference from the built-in PID controller varying the motor speed as part of a closed-loop control process (e.g., constant pressure or flow). The PID controller must be configured in parameter group 20-** or via the Function Set-ups accessed by pressing [Quick Menus].

NOTICE!

This parameter cannot be adjusted while the motor is running.

NOTICE!

When set for Closed-loop, the commands Reversing and Start Reversing will not reverse the direction of the motor.

1-01 Motor Control Principle		
Option:	Function:	
		Select which motor control principle to employ.
[0]	U/f	Special motor mode, for parallel connected motors in special motor applications. When U/f is selected the characteristic of the control principle can be edited in 1-55 V/f Characteristic - V and 1-56 V/f Characteristic - f.
[1]	VVC+	Voltage vector control principle suitable for most applications. The main benefit of VVC ^{plus} operation is that it uses a robust motor model.

NOTICE!

This parameter cannot be adjusted while the motor is running.

1-03 Torque Characteristics		
Option:	Function:	
[0]	Constant torque	For speed control of constant torque applications like axial pumps, positive displacement pumps

1-03 Torque Characteristics		
Option:	Function:	
		and blowers. Provides a voltage which is optimized for a constant torque load characteristic of the motor in the entire range speed.
[1]	Variable torque	For speed control of centrifugal pumps and fans. Also to be used when controlling more than one motor from the same adjustable frequency drive (e.g., multiple condenser fans or cooling tower fans). Provides a voltage which is optimized for a squared torque load characteristic of the motor.
[2]	Auto Energy Optim. CT	For optimum energy efficient speed control of screw and scroll compressors. Provides a voltage that is optimized for a constant torque load characteristic of the motor in the entire range down to 15 Hz. In addition, the AEO feature will adapt the voltage exactly to the current load situation, thereby reducing energy consumption and audible noise from the motor. To obtain optimal performance, the motor power factor cos phi must be set correctly. This value is set in 14-43 Motor Cos-Phi. The parameter has a default value which is automatically adjusted when the motor data is programmed. These settings will typically ensure optimum motor voltage but if the motor power factor cos phi requires tuning, an AMA function can be carried out using 1-29 Automatic Motor Adaptation (AMA). It is very rarely necessary to adjust the motor power factor parameter manually.
[3]	Auto Energy Optim. VT	For optimum energy efficient speed control of centrifugal pumps and fans. Provides a voltage which is optimized for a squared torque load characteristic of the motor but in addition the AEO feature will adapt the voltage exactly to the current load situation, thereby reducing energy consumption and audible noise from the motor. To obtain optimal performance, the motor power factor cos phi must be set correctly. This value is set in 14-43 Motor Cos-Phi. The parameter has a default value and is automatically adjusted when the motor data is programmed. These settings will typically ensure optimum motor voltage but if the motor power factor cos phi requires tuning, an AMA function can be carried out using 1-29 Automatic Motor Adaptation (AMA). It is very rarely necessary to adjust the motor power factor parameter manually.

NOTICE!

1-03 Torque Characteristics will not have effect when 1-10 Motor Construction = [1] PM, non-salient SPM.

1-06 Clockwise Direction		
This parameter defines the term “Clockwise” corresponding to the LCP direction arrow. Used for easy change of direction of shaft rotation without swapping motor wires.		
Option:		Function:
[0]	Normal	Motor shaft will turn in clockwise direction when the adjustable frequency drive is connected U → U; V→V, and W → W to motor.
[1]	Inverse	Motor shaft will turn in counter-clockwise direction when the adjustable frequency drive is connected U→U; V→V, and W→ W to motor.

NOTICE!

This parameter cannot be adjusted while the motor is running.

3.3.2 1-10 Motor Selection

NOTICE!

This parameter group cannot be adjusted while the motor is running.

The following parameters are active ('x') depending on the setting of *1-10 Motor Construction*

1-10 Motor Construction	[0] Asynchron	[1] PM Motor non-salient
1-00 Configuration Mode	x	x
1-03 Torque Characteristics	x	
1-06 Clockwise Direction	x	x
1-14 Damping Gain		x
1-15 Low Speed Filter Time Const.		x
1-16 High Speed Filter Time Const.		x
1-17 Voltage filter time const.		x
1-20 Motor Power [kW]	x	
1-21 Motor Power [HP]	x	
1-22 Motor Voltage	x	
1-23 Motor Frequency	x	
1-24 Motor Current	x	x
1-25 Motor Nominal Speed	x	x
1-26 Motor Cont. Rated Torque		x
1-28 Motor Rotation Check	x	x
1-29 Automatic Motor Adaptation (AMA)	x	
1-30 Stator Resistance (Rs)	x	x
1-31 Rotor Resistance (Rr)	x	
1-35 Main Reactance (Xh)	x	

1-10 Motor Construction	[0] Asynchron	[1] PM Motor non-salient
1-37 d-axis Inductance (Ld)		x
1-39 Motor Poles	x	x
1-40 Back EMF at 1000 RPM		x
1-50 Motor Magnetization at Zero Speed	x	
1-51 Min Speed Normal Magnetizing [RPM]	x	
1-52 Min Speed Normal Magnetizing [Hz]	x	
1-58 Flystart Test Pulses Current	x	x
1-59 Flystart Test Pulses Frequency	x	x
1-60 Low Speed Load Compensation	x	
1-61 High Speed Load Compensation	x	
1-62 Slip Compensation	x	
1-63 Slip Compensation Time Constant	x	
1-64 Resonance Dampening	x	
1-65 Resonance Dampening Time Constant	x	
1-66 Min. Current at Low Speed		x
1-70 PM Start Mode		x
1-71 Start Delay	x	x
1-72 Start Function	x	x
1-73 Flying Start	x	x
1-80 Function at Stop	x	x
1-81 Min Speed for Function at Stop [RPM]	x	x
1-82 Min Speed for Function at Stop [Hz]	x	x
1-86 Trip Speed Low [RPM]	x	x
1-87 Trip Speed Low [Hz]	x	x
1-90 Motor Thermal Protection	x	x
1-91 Motor External Fan	x	x
1-93 Thermistor Source	x	x
2-00 DC Hold/Preheat Current	x	
2-01 DC Brake Current	x	x
2-02 DC Braking Time	x	
2-03 DC Brake Cut-in Speed [RPM]	x	
2-04 DC Brake Cut-in Speed [Hz]	x	
2-06 Parking Current		x
2-07 Parking Time		x
2-10 Brake Function	x	x
2-11 Brake Resistor (ohm)	x	x
2-12 Brake Power Limit (kW)	x	x
2-13 Brake Power Monitoring	x	x
2-15 Brake Check	x	x
2-16 AC Brake Max. Current	x	

1-10 Motor Construction	[0] Asynchron	[1] PM Motor non-salient
2-17 Over-voltage Control	x	
4-10 Motor Speed Direction	x	x
4-11 Motor Speed Low Limit [RPM]	x	x
4-12 Motor Speed Low Limit [Hz]	x	x
4-13 Motor Speed High Limit [RPM]	x	x
4-14 Motor Speed High Limit [Hz]	x	x
4-16 Torque Limit Motor Mode	x	x
4-17 Torque Limit Generator Mode	x	x
4-18 Current Limit	x	x
4-19 Max Output Frequency	x	x
4-58 Missing Motor Phase Function	x	
14-40 VT Level	x	
14-41 AEO Minimum Magnetization	x	
14-42 Minimum AEO Frequency	x	
14-43 Motor Cos-Phi	x	

Table 3.5

1-10 Motor Construction		
Select the motor construction type.		
Option:	Function:	
[0] Asynchron	For asynchronous motors.	
[1] PM, non salient SPM	For permanent magnet (PM) motors. Note that PM motors are divided into two groups, with either surface mounted (non-salient) or interior (salient) magnets. NOTICE! Only available up to 30 hp [22 kW] motor power.	

NOTICE!

Motor construction can either be asynchronous or permanent magnet (PM) motor.

3.3.3 1-14 - 1-17 VVC^{plus} PM

The default control parameters for VVC^{plus} PMSM control core are optimized for applications and inertia load in range of $50 > J_l/J_m > 5$, where J_l is load inertia from the application and j_m is machine inertia.

For low inertia applications $J_l/J_m < 5$ it is recommended that 1-17 Voltage filter time const. be increased with a factor of 5–10 and in some cases 1-14 Damping Gain should also be reduced to improve performance and stability.

For High inertia applications $J_l/J_m \gg 50$, it is recommended that 1-15 Low Speed Filter Time Const., 1-16 High Speed Filter Time Const. and 1-14 Damping Gain be increased to improve performance and stability.

For high load at low speed [$< 30\%$ of rated speed] it is recommended that 1-17 Voltage filter time const. is increased due to non-linearity in the inverter at low speed.

1-14 Damping Gain		
Range:	Function:	
120 %*	[0 - 250 %]	

1-15 Low Speed Filter Time Const.		
Range:	Function:	
Size related*	[0.01 - 20 s]	High pass-filter damping time constant determines the response time to load steps. Obtain quick control through a short damping time constant. However, if this value is too short, the control becomes unstable. This time constant is used below 10% rated speed.

1-16 High Speed Filter Time Const.		
Range:	Function:	
Size related*	[0.01 - 20 s]	High pass-filter damping time constant determines the response time to load steps. Obtain quick control through a short damping time constant. However, if this value is too short, the control becomes unstable. This time constant is used above 10% rated speed.

1-17 Voltage filter time const.		
Range:	Function:	
Size related*	[0.001 - 1 s]	Machine Supply Voltage Filter Time constant is used for reducing the influence of high frequency ripples and system resonances in the calculation of machine supply voltage. Without this filter, the ripples in the currents can distort the calculated voltage and affects the stability of the system.

3.3.4 1-2* Motor Data

Parameter group 1-2* comprises input data from the nameplate on the connected motor.

NOTICE!

Changing the value of these parameters affects the setting of other parameters.

NOTICE!

1-20 Motor Power [kW], 1-21 Motor Power [HP], 1-22 Motor Voltage and 1-23 Motor Frequency will not have effect when 1-10 Motor Construction = [1] PM, non-salient SPM.

1-20 Motor Power [kW]		
Range:		Function:
Size related*	[0.09 - 3000.00 kW]	Enter the nominal motor power in kW according to the motor nameplate data. The default value corresponds to the nominal rated output of the unit. This parameter cannot be adjusted while the motor is running. Depending on the choices made in 0-03 Regional Settings, either 1-20 Motor Power [kW] or 1-21 Motor Power [HP] is made invisible.

1-21 Motor Power [HP]		
Range:		Function:
Size related*	[0.09 - 3000.00 hp]	Enter the nominal motor power in HP according to the motor nameplate data. The default value corresponds to the nominal rated output of the unit. Depending on the choices made in 0-03 Regional Settings, either 1-20 Motor Power [kW] or 1-21 Motor Power [HP] is made invisible. NOTICE! This parameter cannot be adjusted while the motor is running.

1-22 Motor Voltage		
Range:		Function:
Size related*	[10 - 1000 V]	Enter the nominal motor voltage according to the motor nameplate data. The default value corresponds to the nominal rated output of the unit.

NOTICE!

This parameter cannot be adjusted while the motor is running.

1-23 Motor Frequency		
Range:		Function:
Size related*	[20 - 1000 Hz]	Select the motor frequency value from the motor nameplate data. For 87 Hz operation with 230/400 V motors, set the nameplate data for 230 V/50 Hz. Adapt 4-13 Motor Speed High Limit [RPM] and 3-03 Maximum Reference to the 87 Hz application.

NOTICE!

This parameter cannot be adjusted while the motor is running.

1-24 Motor Current		
Range:		Function:
Size related*	[0.10 - 10000.00 A]	Enter the nominal motor current value from the motor nameplate data. This data is used for calculating motor torque, motor thermal protection, etc.

NOTICE!

This parameter cannot be adjusted while the motor is running.

1-25 Motor Nominal Speed		
Range:		Function:
Size related*	[100 - 60000 RPM]	Enter the nominal motor speed value from the motor nameplate data. This data is used for calculating automatic motor compensations.

NOTICE!

This parameter cannot be adjusted while the motor is running.

1-26 Motor Cont. Rated Torque		
Range:		Function:
Size related*	[0.1 - 10000 Nm]	Enter the value from the motor nameplate data. The default value corresponds to the nominal rated output. This parameter is available when 1-10 Motor Construction is set to [1] PM, non-salient SPM, i.e., the

1-26 Motor Cont. Rated Torque	
Range:	Function:
	parameter is valid for PM and non-salient SPM motors only.

1-28 Motor Rotation Check	
Option:	Function:
	Following installation and connection of the motor, this function allows the correct motor rotation direction to be verified. Enabling this function overrides any bus commands or digital inputs, except External Interlock and Safe Stop (if included).
[0]	OFF Motor Rotation Check is not active.
[1]	Enabled Motor Rotation Check is enabled.

NOTICE!

Once the motor rotation check is enabled, the display shows: "Please Note! Motor may run in wrong direction". Pressing [OK], [Back] or [Cancel] will dismiss the message and display a new message: "Press [Hand On] to start the motor. Press [Cancel] to abort". Pressing [Hand On] starts the motor at 5 Hz in the forward direction; the display shows: "Motor is running. Check if motor rotation direction is correct. Press [Off] to stop the motor". Pressing [Off] stops the motor and resets 1-28 Motor Rotation Check. If motor rotation direction is incorrect, two motor phase cables should be interchanged.

WARNING

Line power must be removed before disconnecting motor phase cables.

1-29 Automatic Motor Adaptation (AMA)	
Option:	Function:
	The AMA function optimizes dynamic motor performance by automatically optimizing the advanced motor 1-30 Stator Resistance (R_s) to 1-35 Main Reactance (X_h) while the motor is stationary.
[0]	Off No function
[1]	Enable complete AMA Performs AMA of the stator resistance R_s , the rotor resistance R_r , the stator leakage reactance X_1 , the rotor leakage reactance X_2 and the main reactance X_h .
[2]	Enable reduced AMA Performs a reduced AMA of the stator resistance R_s in the system only. Select this option if an LC filter is used between the adjustable frequency drive and the motor.

NOTICE!

1-29 Automatic Motor Adaptation (AMA) will not have effect when 1-10 Motor Construction = [1] PM, non-salient SPM.

Activate the AMA function by pressing [Hand On] after selecting [1] Enable complete AMA or [2] Enable reduced AMA. See also the item Automatic Motor Adaptation in the Design Guide. After a normal sequence, the display will read: "Press [OK] to finish AMA". After pressing [OK] the adjustable frequency drive is ready for operation.

NOTICE!

- For the best adaptation of the adjustable frequency drive, run AMA on a cold motor
- AMA cannot be performed while the motor is running

NOTICE!

Avoid generating external torque during AMA.

NOTICE!

If one of the settings in parameter group 1-2* Motor Data is changed, 1-30 Stator Resistance (R_s) to 1-39 Motor Poles, the advanced motor parameters, will return to default setting.

This parameter cannot be adjusted while the motor is running.

NOTICE!

Full AMA should be run without filter only while reduced AMA should be run with filter.

See section: Application Examples > Automatic Motor Adaptation in the VLT AQUA Drive Design Guide, MG20NXYY.

3.3.5 1-3* Adv. Motor Data

Parameters for advanced motor data. The motor data in 1-30 Stator Resistance (R_s) to 1-39 Motor Poles must match the relevant motor in order to run the motor optimally. The default settings are figures based on common motor parameter values from normal standard motors. If the motor parameters are not set correctly, a malfunction of the adjustable frequency drive system may occur. If the motor data is not known, running an AMA (Automatic Motor Adaptation) is recommended. See section: Application Examples > Automatic Motor Adaptation in the VLT AQUA Drive Design Guide, MG20N. The AMA sequence will adjust all motor parameters except the moment of inertia of the rotor and the iron loss resistance (1-36 Iron Loss Resistance (R_{fe})).

3

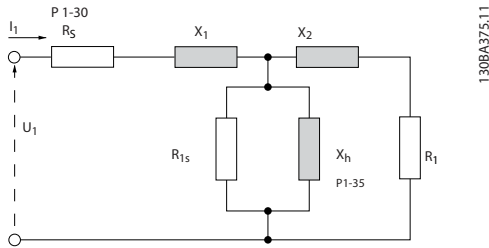

Figure 3.4 Motor Equivalent Diagram for an Asynchronous Motor

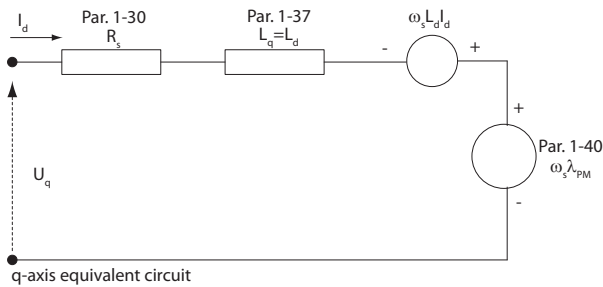
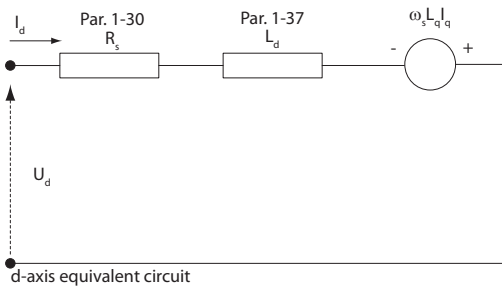

Figure 3.5 Motor Equivalent Circuit Diagram for a PM Non-salient Motor

1-30 Stator Resistance (Rs)		
Range:	Function:	
Size related*	[0.0140 - 140.0000 Ohm]	Set the stator resistance value. Enter the value from a motor data sheet or perform an AMA on a cold motor.

NOTICE!

This parameter cannot be adjusted while the motor is running.

1-31 Rotor Resistance (Rr)		
Range:	Function:	
Size related*	[0.0100 - 100.0000 Ohm]	Fine-tuning Rr will improve shaft performance. Set the rotor resistance value using one of these methods: <ol style="list-style-type: none"> 1. Run an AMA on a cold motor. The adjustable frequency drive will measure the value from the motor. All compensations are reset to 100%. 2. Enter the Rr value manually. Obtain the value from the motor supplier. 3. Use the Rr default setting. The adjustable frequency drive establishes the setting on the basis of the motor nameplate data.

NOTICE!

1-31 Rotor Resistance (Rr) will not have effect when 1-10 Motor Construction = [1] PM, non-salient SPM.

1-33 Stator Leakage Reactance (X1)		
Range:	Function:	
Size related*	[0.0400 - 400.0000 Ohm]	Set the stator leakage reactance of the motor using one of these methods: <ol style="list-style-type: none"> 1. Run an AMA on a cold motor. The adjustable frequency drive will measure the value from the motor. 2. Enter the X1 value manually. Obtain the value from the motor supplier. 3. Use the X1 default setting. The adjustable frequency drive establishes the setting on the basis of the motor nameplate data. See Figure 3.4.

NOTICE!

1-33 Stator Leakage Reactance (X1) will not have effect when 1-10 Motor Construction = [1] PM, non-salient SPM.

1-34 Rotor Leakage Reactance (X ₂)		
Range:		Function:
Size related*	[0.0400 - 400.0000 Ohm]	Set the rotor leakage reactance of the motor using one of these methods: <ol style="list-style-type: none"> 1. Run an AMA on a cold motor. The adjustable frequency drive will measure the value from the motor. 2. Enter the X₂ value manually. Obtain the value from the motor supplier. 3. Use the X₂ default setting. The adjustable frequency drive establishes the setting on the basis of the motor nameplate data. See Figure 3.4.

NOTICE!

1-34 Rotor Leakage Reactance (X₂) will not have effect when 1-10 Motor Construction = [1] PM, non-salient SPM.

1-35 Main Reactance (X _h)		
Range:		Function:
Size related*	[1.0000 - 10000.0000 Ohm]	Set the main reactance of the motor using one of these methods: <ol style="list-style-type: none"> 1. Run an AMA on a cold motor. The adjustable frequency drive will measure the value from the motor. 2. Enter the X_h value manually. Obtain the value from the motor supplier. 3. Use the X_h default setting. The adjustable frequency drive establishes the setting on the basis of the motor nameplate data.

NOTICE!

1-35 Main Reactance (X_h) will not have effect when 1-10 Motor Construction = [1] PM, non-salient SPM.

NOTICE!

This parameter cannot be adjusted while running.

1-36 Iron Loss Resistance (R _{Fe})		
Range:		Function:
Size related*	[0 - 10000.0000 Ohm]	Enter the equivalent iron loss resistance (R _{Fe}) value to compensate for iron losses in the motor. The R _{Fe} value cannot be found by performing an AMA. The R _{Fe} value is especially important in torque control applications. If R _{Fe} is unknown, leave 1-36 Iron Loss Resistance (R _{Fe}) on default setting.

NOTICE!

This parameter cannot be adjusted while the motor is running.

NOTICE!

This parameter is not available from the LCP.

1-37 d-axis Inductance (L _d)		
Range:		Function:
Size related*	[0.000 - 0.000 mH]	Enter the value of the d-axis inductance. Obtain the value from the permanent magnet motor data sheet.

NOTICE!

This parameter is only active when 1-10 Motor Construction has the value PM, non-salient SPM [1] (Permanent Magnet Motor).

Stator resistance and d-axis Inductance values are normally, for asynchronous motors, described in technical specifications as between line and common (starpoint). For permanent magnet motors, they are typically described in technical specifications as between Line-Line. PM motors are typically built for star connection.

1-30 Stator Resistance (Rs) (Line to common)	This parameter gives stator winding resistance (Rs) Similar to Asynchronous Motor Stator resistance. The Stator resistance is defined for line to common measurement. That means for line-line data (Where stator resistance is measured between any two lines you need to divide it with 2).
1-37 d-axis Inductance (Ld) (Line to common)	This parameter gives direct axis inductance of the PM motor. The d-axis inductance is defined for phase to common measurement. That means for line-line data (Where stator resistance is measured between any two lines divide it with 2
1-40 Back EMF at 1000 RPM RMS (Line to Line Value)	This parameter gives back emf across stator terminal of PM Motor at 1,000 rpm mechanical speed specifically. It is defined line to line and expressed in RMS Value

Table 3.6

NOTICE!

Motor manufacturers provide values for Stator resistance (1-30 Stator Resistance (Rs)) and d-axis Inductance (1-37 d-axis Inductance (Ld)) in technical specifications as between line and common (starpoint) or between Line-Line. There is no general standard. The different setups for Stator Winding Resistance and Induction are shown in Figure 3.6. Danfoss inverters always require the line to common value. The back EMF of PM motor is defined as 'Induced EMF developed across any of two phases of stator winding of free running Motor'. Danfoss inverters always require the Line to Line RMS value measured at 1,000 rpm, mechanical speed of rotation. This is shown in Figure 3.7)

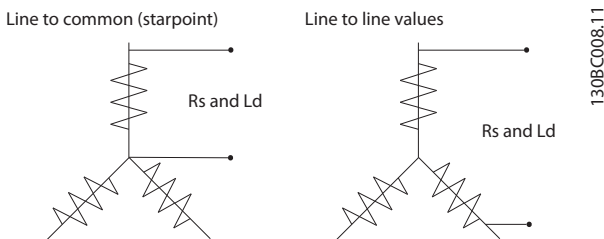

Figure 3.6 Motor parameters are provided in different formats. Danfoss adjustable frequency drives always require the line to common value.

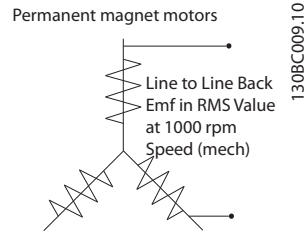

Figure 3.7 Machine parameter definitions of Back EMF of permanent magnet motors

1-39 Motor Poles			
Range:		Function:	
Size related*	[2 - 100]	Enter the number of motor poles.	
		Poles	~n_n@ 50 Hz
		2	2,700–2,880
		4	1,350–1,450
		6	700–960
			~n_n@ 60 Hz
			3,250–3,460
			1,625–1,730
			840–1,153
<p>Table 3.8</p> <p>The table shows the number of poles for normal speed ranges of various motor types. Define motors designed for other frequencies separately. The motor pole value is always an even number, because it refers to the total number of poles, not pairs of poles. The adjustable frequency drive creates the initial setting of 1-39 Motor Poles based on 1-23 Motor Frequency Motor Frequency and 1-25 Motor Nominal Speed Motor Nominal Speed.</p>			

NOTICE!

This parameter cannot be adjusted while the motor is running.

1-40 Back EMF at 1000 RPM		
Range:		Function:
Size related*	[10 - 9000 V]	Set the nominal back EMF for the motor when running at 1,000 RPM. This parameter is only active when 1-10 Motor Construction is set to PM motor [1] (Permanent Magnet Motor).

3.3.6 1-5* Load Indep. Setting

1-50 Motor Magnetization at Zero Speed		
Range:	Function:	
100 %*	[0 - 300 %]	

NOTICE!

1-50 Motor Magnetization at Zero Speed will not have effect when 1-10 Motor Construction = [1] PM, non-salient SPM.

1-51 Min Speed Normal Magnetizing [RPM]		
Range:	Function:	
Size related*	[10 - 300 RPM]	Set the required speed for normal magnetizing current. If the speed is set lower than the motor slip speed, 1-50 Motor Magnetization at Zero Speed and 1-51 Min Speed Normal Magnetizing [RPM] are of no significance. Use this parameter along with 1-50 Motor Magnetization at Zero Speed. See Table 3.8.

NOTICE!

1-51 Min Speed Normal Magnetizing [RPM] will not have effect when 1-10 Motor Construction = [1] PM, non-salient SPM.

1-52 Min Speed Normal Magnetizing [Hz]		
Range:	Function:	
Size related*	[0.3 - 10.0 Hz]	Set the required frequency for normal magnetizing current. If the frequency is set lower than the motor slip frequency, 1-50 Motor Magnetization at Zero Speed and 1-51 Min Speed Normal Magnetizing [RPM] are inactive. Use this parameter along with 1-50 Motor Magnetization at Zero Speed. See Table 3.8.

NOTICE!

1-52 Min Speed Normal Magnetizing [Hz] will not have effect when 1-10 Motor Construction = [1] PM, non-salient SPM.

1-55 V/f Characteristic - V		
Range:	Function:	
Size related*	[0 - 1000 V]	Enter the voltage at each frequency point to manually form a U/f characteristic matching the motor. The frequency points are defined in 1-56 V/f Characteristic - f. This parameter is an array parameter [0-5] and is only accessible when

1-55 V/f Characteristic - V		
Range:	Function:	
		1-01 Motor Control Principle is set to [0] U/f.

1-56 V/f Characteristic - f		
Range:	Function:	
Size related*	[0 - 1000.0 Hz]	Enter the frequency points to manually form a U/f-characteristic matching the motor. The voltage at each point is defined in 1-55 V/f Characteristic - V. This parameter is an array parameter [0-5] and is only accessible when 1-01 Motor Control Principle is set to [0] U/f.

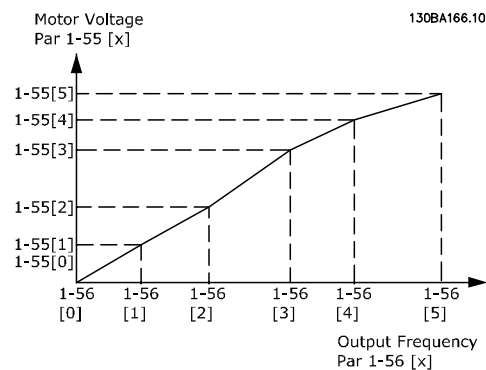

Figure 3.9

1-58 Flystart Test Pulses Current		
Range:	Function:	
Size related*	[0 - 0 %]	Set the magnitude of the magnetizing current for the pulses used to detect the motor direction. The value range and function depends on parameter 1-10 Motor Construction: [0] Asynchron: [0-200%] Reducing this value will reduce the generated torque. 100% means full nominal motor current. In this case, the default value is 30%. [1] PM non-salient: [0-40%] A general setting of 20% is recommended on PM motors. Higher values can give increased performance. However, on motors with back EMF higher than 300VLL (rms) at nominal speed and high winding inductance (more than 10mH) a lower value is recommended to avoid wrong speed estimation. The parameter is active when 1-73 Flying Start is enabled.

NOTICE!

See description of *1-70 PM Start Mode* for an overview of the relation between the PM Flying Start parameters.

1-59 Flystart Test Pulses Frequency		
Range:	Function:	
Size related*	[0 - 0 %]	The value range and function depends on parameter <i>1-10 Motor Construction</i> : [0] Asynchron: [0-500%] Control the percentage of the frequency for the pulses used to detect the motor direction. Increasing this value will reduce the generated torque. In this mode 100% means two times the slip frequency. [1] PM non-salient: [0-10%] This parameter defines the motor speed (in % of nominal motor speed) below which the Parking function (see <i>2-06 Parking Current</i>) and <i>2-07 Parking Time</i> will become active. This parameter is only active when <i>1-70 PM Start Mode</i> is set to [1] Parking and only after starting the motor.

3.3.7 1-6* Load Depend. Setting

1-60 Low Speed Load Compensation		
Range:	Function:	
100 %*	[0 - 300 %]	

NOTICE!

1-60 Low Speed Load Compensation will not have effect when *1-10 Motor Construction* = [1] PM, non-salient SPM.

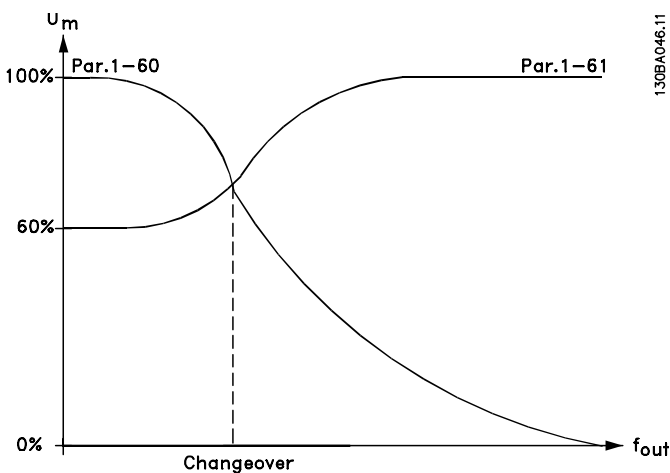

Figure 3.10

130BA046.11

1-61 High Speed Load Compensation		
Range:	Function:	
100 %*	[0 - 300 %]	

NOTICE!

1-61 High Speed Load Compensation will not have effect when *1-10 Motor Construction* = [1] PM, non-salient SPM.

1-62 Slip Compensation		
Range:	Function:	
0 %*	[-500 - 500 %]	

NOTICE!

1-62 Slip Compensation will not have effect when *1-10 Motor Construction* = [1] PM, non-salient SPM.

1-63 Slip Compensation Time Constant		
Range:	Function:	
Size related*	[0.05 - 5 s]	Enter the slip compensation reaction speed. A high value results in slow reaction, and a low value results in quick reaction. If low-frequency resonance problems arise, use a longer time setting.

NOTICE!

1-63 Slip Compensation Time Constant will not have effect when *1-10 Motor Construction* = [1] PM, non-salient SPM.

1-64 Resonance Dampening		
Range:	Function:	
100 %*	[0 - 500 %]	

NOTICE!

1-64 Resonance Dampening will not have effect when *1-10 Motor Construction* = [1] PM, non-salient SPM.

1-65 Resonance Dampening Time Constant		
Range:	Function:	
5 ms*	[5 - 50 ms]	Set <i>1-64 Resonance Dampening</i> and <i>1-65 Resonance Dampening Time Constant</i> to help eliminate high-frequency resonance problems. Enter the time constant that provides the best dampening.

NOTICE!

1-65 Resonance Dampening Time Constant will not have effect when *1-10 Motor Construction* = [1] PM, non-salient SPM.

1-66 Min. Current at Low Speed		
Range:	Function:	
Size related* [1 - 200 %]	Enter the minimum motor current at low speed. Increasing this current improves developed motor torque at low speed. Low speed is defined here as speeds below 6% of the Nominal Speed of Motor (1-25 Motor Nominal Speed) in VVC ^{plus} PM Control	

NOTICE!

1-66 Min. Current at Low Speed will not have effect if 1-10 Motor Construction=[0]

3.3.8 1-7* Start Adjustments

1-70 PM Start Mode		
Option:	Function:	
[0] Rotor Detection	Suitable for all applications where the motor is known to be standing still when starting (e.g., conveyors, pumps and non-windmilling fans).	
[1] Parking	If the motor turns at a slight speed (i.e., lower than 2–5% of the nominal speed), e.g., due to fans with light windmilling, select [1] Parking and adjust 2-06 Parking Current and 2-07 Parking Time accordingly.	

1-71 Start Delay		
Range:	Function:	
00 s* [0 - 120 s]	The function selected in 1-80 Function at Stop is active in the delay period. Enter the time delay required before commencing acceleration.	

1-72 Start Function		
Option:	Function:	
	Select the start function during start delay. This parameter is linked to 1-71 Start Delay.	
[0] DC Hld/Motr Preheat	Energizes motor with a DC holding current (2-00 DC Hold/Preheat Current) during the start delay time.	
[2] Coast	Motor coasted during the start delay time (inverter off). Available selections depend on 1-10 Motor Construction: [0] Asynchron: [2] coast [0] DC hold	

1-72 Start Function		
Option:	Function:	
	[1] PM non-salient: [2] coast	

1-73 Flying Start		
Option:	Function:	
	This function makes it possible to catch a motor that is spinning freely due to a line drop-out. When 1-73 Flying Start is enabled, 1-71 Start Delay has no function. Search direction for Flying Start is linked to the setting in 4-10 Motor Speed Direction. [0] Clockwise: Flying Start search in clockwise direction. If not successful, a DC brake is carried out. [2] Both Directions: The Flying Start will first make a search in the direction determined by the last reference (direction). If unable to find the speed, it will search in the other direction. If not successful, a DC brake will be activated in the time set in 2-02 DC Braking Time. Start will then take place from 0 Hz.	
[0] Disabled	Select [0] Disable if this function is not required	
[1] Enabled	Select [1] Enable to enable the adjustable frequency drive to "catch" and control a spinning motor. The parameter is always set to [1] Enable when 1-10 Motor Construction = [1] PM non-salient. Important related parameters: <ul style="list-style-type: none"> • 1-58 Flystart Test Pulses Current • 1-59 Flystart Test Pulses Frequency • 1-70 PM Start Mode • 2-06 Parking Current • 2-07 Parking Time • 2-03 DC Brake Cut-in Speed [RPM] • 2-04 DC Brake Cut-in Speed [Hz] • 2-06 Parking Current • 2-07 Parking Time 	

When 1-73 Flying Start is enabled, 1-71 Start Delay has no function.

Search direction for Flying Start is linked to the setting in 4-10 Motor Speed Direction.
 [0] Clockwise: Flying Start search in clockwise direction. If not successful, a DC brake is carried out.
 [2] Both Directions: The Flying Start will first make a search in the direction determined by the last reference

3

(direction). If unable to find the speed, it will search in the other direction. If not successful, a DC brake will be activated in the time set in 2-02 *DC Braking Time*. Start will then take place from 0 Hz.

The Flystart function used for PM motors is based on an initial speed estimation. The speed will always be estimated as the first thing after an active start signal is given. Based on the setting of 1-70 *PM Start Mode*, the following will happen:

1-70 *PM Start Mode* = [0] *Rotor Detection*:

If the speed estimate comes out as greater than 0 Hz, the adjustable frequency drive will catch the motor at that speed and resume normal operation. Otherwise, the adjustable frequency drive will estimate the rotor position and start normal operation from there.

1-70 *PM Start Mode* = [1] *Parking*:

If the speed estimate comes out lower than the setting in 1-59 *Flystart Test Pulses Frequency*, then the Parking function will be engaged (see 2-06 *Parking Current* and 2-07 *Parking Time*). Otherwise, the adjustable frequency drive will catch the motor at that speed and resume normal operation. Refer to description of 1-70 *PM Start Mode* for recommended settings.

Current limitations of the Flystart Principle used for PM motors:

- The speed range is up to 100% Nominal Speed or the field weakening speed (which ever is lowest).
- PMSM with high back emf (>300 VLL(rms)) and high winding inductance (>10 mH) needed more time for reducing short circuit current to zero and may be susceptible to error in estimation.
- Current testing limited to a speed range up to 300 Hz. For certain units, the limit is 250 Hz; all 200–240 V units up to and including 3 HP [2.2 kW] and all 380–480 V units up to and including 5.4 HP [4 kW].
- Current testing limited to a machine power size up to 30 HP [22 kW].
- Prepared for salient pole machine (IPMSM) but not yet verified on those types of machine.
- For high inertia applications (i.e., where the load inertia is more than 30 times larger than the motor inertia), a brake resistor is recommended to avoid overvoltage trip during high speed engagement of the Flystart function.

1-74 Start Speed [RPM]		
Range:		Function:
Size related*	[0 - 600 RPM]	Set a motor start speed. After the start signal, the output speed leaps to set value. Set the start function in 1-72 <i>Start Function</i> and set a start delay time in 1-71 <i>Start Delay</i> .

1-75 Start Speed [Hz]		
Range:		Function:
Size related*	[0 - 500.0 Hz]	This parameter can be used for hoist applications (cone rotor). Set a motor start speed. After the start signal, the output speed leaps to set value. Set the start function in 1-72 <i>Start Function</i> and set a start delay time in 1-71 <i>Start Delay</i> .

1-76 Start Current		
Range:		Function:
0 A*	[0 - par. 1-24 A]	Some motors, e.g., cone rotor motors, need extra current/starting speed to disengage the rotor. To obtain this boost, set the required current in 1-76 <i>Start Current</i> . Set 1-72 <i>Start Function</i> to [0] <i>DC Hold/Motor Preheat</i> , and set a start delay time in 1-71 <i>Start Delay</i> .

3.3.9 1-8* Stop Adjustments

1-80 Function at Stop		
Option:	Function:	
		Select the adjustable frequency drive function after a stop command or after the speed is ramped down to the settings in 1-81 <i>Min Speed for Function at Stop [RPM]</i> . Available selections depend on 1-10 <i>Motor Construction</i> : [0] Asynchron: [0] coast [1] DC hold [1] PM non-salient: [0] coast
[0]	Coast	Leaves motor in free mode.

1-81 Min Speed for Function at Stop [RPM]		
Range:		Function:
Size related*	[0 - 600 RPM]	

1-82 Min Speed for Function at Stop [Hz]	
Range:	Function:
Size related*	[0 - 20.0 Hz]

1-86 Trip Speed Low [RPM]		
Range:	Function:	
Size related*	[0 - par. 4-13 RPM]	Set the desired motor speed for trip limit. If the trip speed is set to 0, the function is not active. If the speed at any time after the start (or during a stop) falls below the value in the parameter, the adjustable frequency drive will trip with an alarm [A49] Speed Limit. Function at stop.

NOTICE!

This parameter is only available if 0-02 Motor Speed Unit is set to [RPM].

1-87 Trip Speed Low [Hz]		
Range:	Function:	
Size related*	[0 - par. 4-14 Hz]	If the trip speed is set to 0, the function is not active. If the speed at any time after the start (or during a stop) falls below the value in the parameter, the adjustable frequency drive will trip with an alarm [A49] Speed Limit. Function at stop.

NOTICE!

This parameter is only available if 0-02 Motor Speed Unit is set to [Hz].

3.3.10 1-9* Motor Temperature

1-90 Motor Thermal Protection	
Option:	Function:
	<p>The adjustable frequency drive determines the motor temperature for motor protection in two different ways:</p> <ul style="list-style-type: none"> Via a thermistor sensor connected to one of the analog or digital inputs (1-93 Thermistor Source). Via calculation (ETR = Electronic Thermal Relay) of the thermal load, based on the actual load and time. The calculated thermal load is compared with the rated motor current $I_{M,N}$ and the rated motor frequency $f_{M,N}$. The calculations estimate the need for a lower load at lower speed due to less

1-90 Motor Thermal Protection		
Option:	Function:	
		cooling from the fan incorporated in the motor.
[0]	No protection	If the motor is continuously overloaded and no warning or trip of adjustable frequency drive is wanted.

ETR (Electronic Thermal Relay) functions 1-4 will calculate the load when the set-up where they were selected is active. For example, ETR-3 starts calculating when set-up 3 is selected. For the North American market: The ETR functions provide class 20 motor overload protection in accordance with NEC.

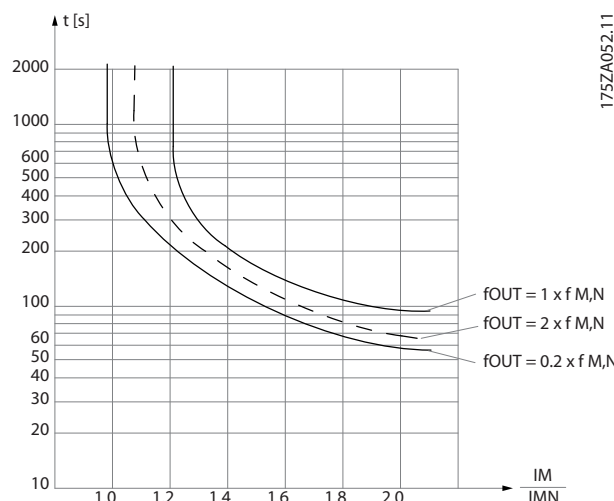

Figure 3.11

WARNING

In order to maintain PELV, all connections made to the control terminals must be PELV, e.g., thermistor must be reinforced/double-insulated.

NOTICE!

Danfoss recommends using 24 V DC as thermistor supply voltage.

NOTICE!

The ETR timer function does not work when 1-10 Motor Construction = [1] PM, non-salient SPM.

NOTICE!

For correct operation of ETR function, setting in 1-03 Torque Characteristics must fit the application (see description of 1-03 Torque Characteristics).

1-91 Motor External Fan		
Option: Function:		
[0]	No	No external fan is required, i.e., the motor is derated at low speed.
[1]	Yes	Applies an external motor fan (external ventilation), so that no derating of the motor is required at low speed. The upper curve in graph above ($f_{out} = 1 \times f_{M,N}$) is followed if the motor current is lower than nominal motor current (see 1-24 Motor Current). If the motor current exceeds nominal current, the operation time still decreases as if no fan were installed.

1-93 Thermistor Source		
Option:		Function:
		Select the input to which the thermistor (PTC sensor) should be connected. An analog input option [1] or [2] cannot be selected if the analog input is already in use as a reference source (selected in 3-15 Reference 1 Source, 3-16 Reference 2 Source or 3-17 Reference 3 Source). When using MCB 112, choice [0] None must always be selected.
[0]	None	
[1]	Analog Input 53	
[2]	Analog Input 54	
[3]	Digital input 18	
[4]	Digital input 19	
[5]	Digital input 32	
[6]	Digital input 33	

NOTICE!

This parameter cannot be adjusted while the motor is running.

NOTICE!

Digital input should be set to [0] PNP - Active at 24 V in 5-00 Digital I/O Mode.

3.4 Parameters 2-** Brakes

3.4.1 2-0* DC Brakes

Parameter group for configuring the DC brake and DC hold functions.

2-00 DC Hold/Preheat Current		
Range:	Function:	
50 %*	[0 - 160 %]	

NOTICE!

2-00 DC Hold/Preheat Current will not have effect when **1-10 Motor Construction = [1] PM, non-salient SPM**.

NOTICE!

The maximum value depends on the rated motor current. Avoid 100% current for too long. It may damage the motor.

2-01 DC Brake Current		
Range:	Function:	
50 %*	[0 - 1000 %]	

NOTICE!

The maximum value depends on the rated motor current. Avoid 100% current for too long. It may damage the motor.

2-02 DC Braking Time		
Range:	Function:	
10 s*	[0 - 60 s]	Set the duration of the DC braking current set in 2-01 DC Brake Current , once activated.

2-03 DC Brake Cut-in Speed [RPM]		
Range:	Function:	
Size related*	[0 - 0 RPM]	Set the DC brake cut-in speed for activation of the DC braking current set in 2-01 DC Brake Current , upon a stop command. When 1-10 Motor Construction is set to [1] PM non-salient SPM , this value is limited to 0 rpm (OFF)

NOTICE!

2-03 DC Brake Cut-in Speed [RPM] will not have effect when **1-10 Motor Construction = [1] PM, non-salient SPM**.

2-04 DC Brake Cut-in Speed [Hz]		
Range:	Function:	
Size related*	[0 - 0.0 Hz]	

NOTICE!

2-04 DC Brake Cut-in Speed [Hz] will not have effect when **1-10 Motor Construction = [1] PM, non-salient SPM**.

2-06 Parking Current		
Range:	Function:	
50 %*	[0 - 1000 %]	

NOTICE!

2-06 Parking Current and **2-07 Parking Time**: Only active if **PM motor construction** is selected in **1-10 Motor Construction**.

2-07 Parking Time		
Range:	Function:	
3 s*	[0.1 - 60 s]	Set the duration of the ing current time set in 2-06 Parking Current . Active in connection with 1-73 Flying Start .

3.4.2 2-1* Brake Energy Funct.

Parameter group for selecting dynamic braking parameters. Only valid for adjustable frequency drives with brake chopper.

2-10 Brake Function		
Option:	Function:	
	Available selections depend on 1-10 Motor Construction :	
	[0] Asynchron:	
	[0]	off
	[1]	Resistor brake
	[2]	AS brake
	[1] PM non-salient:	
	[0]	off
	[1]	Resistor brake
[0]	Off	No brake resistor installed.

2-11 Brake Resistor (ohm)		
Range:	Function:	
Size related*	[5.00 - 65535.00 Ohm]	Set the brake resistor value in Ohms. This value is used for monitoring the power to the brake resistor in 2-13 Brake Power Monitoring . This parameter is only active in adjustable frequency drives with an integral dynamic brake. Use this parameter for values without decimals. For a selection with two decimals, use 30-81 Brake Resistor (ohm) .

2-12 Brake Power Limit (kW)		
Range:	Function:	
Size related* [0.001 - 2000.000 kW]	Set the monitoring limit of the braking energy transmitted to the resistor. The monitoring limit is a product of the maximum duty cycle (120 s) and the maximum power of the brake resistor at that duty cycle. See the formula below. For 200–240 V units: $P_{resistor} = \frac{390^2 \times dutytime}{R \times 120}$ For 380–480 V units: $P_{resistor} = \frac{778^2 \times dutytime}{R \times 120}$ For 525–600 V units: $P_{resistor} = \frac{943^2 \times dutytime}{R \times 120}$	

NOTICE!

This parameter is only active in adjustable frequency drives with an integral dynamic brake.

2-13 Brake Power Monitoring		
Option:	Function:	
	This parameter is only active in adjustable frequency drives with an integral dynamic brake. This parameter enables monitoring of the power to the brake resistor. The power is calculated on the basis of the resistance (2-11 Brake Resistor (ohm), the DC link voltage, and the resistor duty time.	
[0]	Off	No braking energy monitoring is required.
[1]	Warning	Activates a warning on the display when the power transmitted over 120 s exceeds 100% of the monitoring limit (2-12 Brake Power Limit (kW)). The warning disappears when the transmitted power falls below 80% of the monitoring limit.
[2]	Trip	Trips the adjustable frequency drive and displays an alarm when the calculated power exceeds 100% of the monitoring limit.
[3]	Warning and trip	Activates both of the above, including warning, trip and alarm.

If power monitoring is set to [0] Off or [1] Warning, the brake function remains active even if the monitoring limit is exceeded. This may lead to thermal overload of the resistor. It is also possible to generate a warning via a relay/digital output. The measuring accuracy of the power monitoring depends on the accuracy of the resistance of the resistor (better than ±20%).

2-15 Brake Check		
Option:	Function:	
	Select type of test and monitoring function to check the connection to the brake resistor, or whether a brake resistor is present, and then display a warning or an alarm in the event of a fault. The brake resistor disconnection function is tested during power-up. However, the brake IGBT test is performed when there is no braking. A warning or trip disconnects the brake function. The testing sequence is as follows: <ol style="list-style-type: none"> The DC link ripple amplitude is measured for 300 ms without braking. The DC link ripple amplitude is measured for 300 ms with the brake turned on. If the DC link ripple amplitude while braking is lower than the DC link ripple amplitude before braking, +1%. Brake check failed, return a warning or alarm. If the DC link ripple amplitude while braking is higher than the DC link ripple amplitude before braking, +1%. Brake check OK. 	
[0]	Off	Monitors brake resistor and brake IGBT for a short-circuit during operation. If a short-circuit occurs, a warning appears.
[1]	Warning	Monitors brake resistor and brake IGBT for a short-circuit, and to run a test for brake resistor disconnection during power-up.
[2]	Trip	Monitors for a short-circuit or disconnection of the brake resistor, or a short-circuit of the brake IGBT. If a fault occurs, the adjustable frequency drive cuts out while displaying an alarm (trip locked).
[3]	Stop and trip	Monitors for a short-circuit or disconnection of the brake resistor, or a short-circuit of the brake IGBT. If a fault occurs, the adjustable frequency drive ramps down to coast and then trips. A trip lock alarm is displayed.
[4]	AC brake	

NOTICE!

Remove a warning arising in connection with [0] Off or [1] Warning by cycling the line power supply. The fault must be corrected first. For [0] Off or [1] Warning, the adjustable frequency drive keeps running even if a fault is located.

2-16 AC Brake Max. Current		
Range:		Function:
100 %*	[0 - 1000.0 %]	

NOTICE!

2-16 AC Brake Max. Current will not have effect when
 1-10 Motor Construction = [1] PM, non-salient SPM.

2-17 Over-voltage Control		
Option:	Function:	
[0]	Disabled	No OVC required.
[2]	Enabled	Activates OVC.

NOTICE!

2-17 Over-voltage Control will not have effect when
 1-10 Motor Construction = [1] PM, non-salient SPM.

NOTICE!

The ramp time is automatically adjusted to avoid tripping
 of the adjustable frequency drive.

3.5 Parameters 3-** Reference/Ramps

3.5.1 3-0* Reference Limits

3-02 Minimum Reference		
Range:		Function:
Size related*	[-999999.999 - par. 3-03 ReferenceFeed-backUnit]	Enter the desired minimum value for the remote reference. The Minimum Reference value and unit matches the configuration choice made in 1-00 Configuration Mode and 20-12 Reference/Feedback Unit, respectively.

3-03 Maximum Reference		
Range:		Function:
Size related*	[par. 3-02 - 999999.999 ReferenceFeed-backUnit]	Enter the maximum acceptable value for the remote reference. The Maximum Reference value and unit matches the configuration choice made in 1-00 Configuration Mode and 20-12 Reference/Feedback Unit, respectively.

3-04 Reference Function		
Option:		Function:
[0]	Sum	Sums both external and preset reference sources.
[1]	External/Preset	Use either the preset or the external reference source. Shift between external and preset via a command or a digital input.

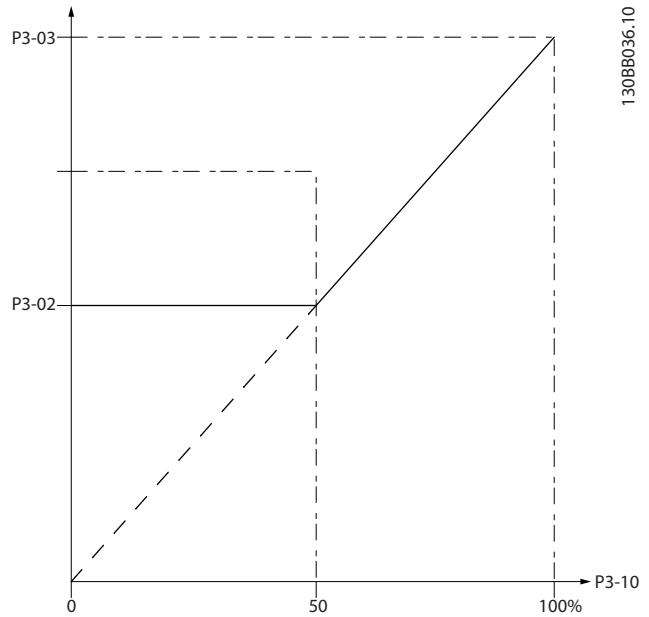

Figure 3.12

130BA149.10

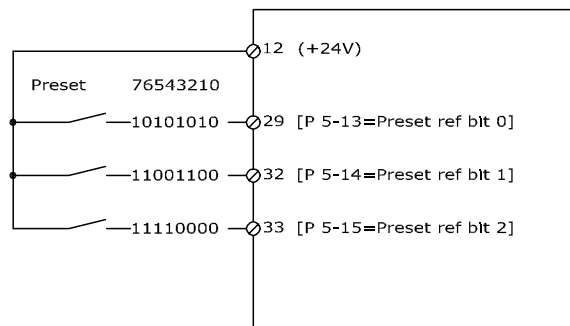

Figure 3.13

3.5.2 3-1* References

Select the preset reference(s). Select Preset ref. bit 0/1/2 [16], [17] or [18] for the corresponding digital inputs in parameter group 5-1*.

3-10 Preset Reference		
Range:		Function:
Array [8]		
0 %*	[-100 - 100 %]	

3-11 Jog Speed [Hz]		
Range:		Function:
Size related*	[0 - par. 4-14 Hz]	The jog speed is a fixed output speed at which the adjustable frequency drive is running when the jog function is activated. See also 3-80 Jog Ramp Time.

3-13 Reference Site		
Option:	Function:	
		Select which reference site to activate.
[0]	Linked to Hand / Auto	Use local reference when in hand mode; or remote reference when in auto mode.
[1]	Remote	Use remote reference in both hand mode and auto mode.
[2]	Local	Use local reference in both hand mode and auto mode. NOTICE! When set to [2] Local, the adjustable frequency drive will start with this setting again following a 'power-down'.

3-14 Preset Relative Reference		
Range:	Function:	
0 %*	[-100 - 100 %]	

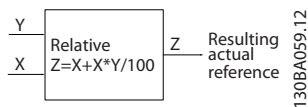

Figure 3.14

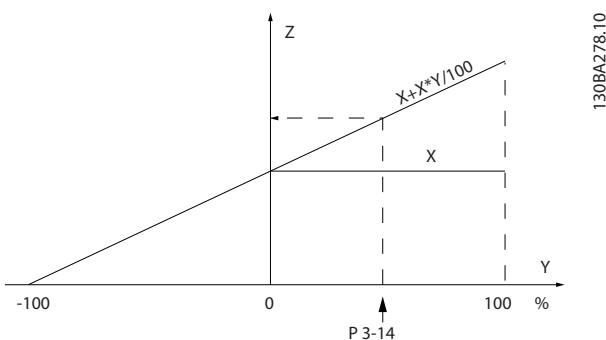

Figure 3.15

3-15 Reference 1 Source		
Option:	Function:	
		Select the reference input to be used for the first reference signal. 3-15 Reference 1 Source, 3-16 Reference 2 Source and 3-17 Reference 3 Source define up to three different reference signals. The sum of these reference signals defines the actual reference.
[0]	No function	
[1]	Analog Input 53	
[2]	Analog Input 54	

3-15 Reference 1 Source		
Option:	Function:	
[7]	Pulse input 29	
[8]	Pulse input 33	
[20]	Digital pot.meter	
[21]	Analog input X30/11	
[22]	Analog input X30/12	
[23]	Analog Input X42/1	
[24]	Analog Input X42/3	
[25]	Analog Input X42/5	
[29]	Analog Input X48/2	
[30]	Ext. Closed-loop 1	
[31]	Ext. Closed-loop 2	
[32]	Ext. Closed-loop 3	

NOTICE!

This parameter cannot be adjusted while the motor is running.

3-16 Reference 2 Source		
Option:	Function:	
		Select the reference input to be used for the second reference signal. 3-15 Reference 1 Source, 3-16 Reference 2 Source and 3-17 Reference 3 Source define up to three different reference signals. The sum of these reference signals defines the actual reference.
[0]	No function	
[1]	Analog Input 53	
[2]	Analog Input 54	
[7]	Pulse input 29	
[8]	Pulse input 33	
[20]	Digital pot.meter	
[21]	Analog input X30/11	
[22]	Analog input X30/12	
[23]	Analog Input X42/1	
[24]	Analog Input X42/3	
[25]	Analog Input X42/5	
[29]	Analog Input X48/2	
[30]	Ext. Closed-loop 1	
[31]	Ext. Closed-loop 2	
[32]	Ext. Closed-loop 3	

NOTICE!

This parameter cannot be adjusted while the motor is running.

3-17 Reference 3 Source		
Option:	Function:	
		Select the reference input to be used for the third reference signal. 3-15 Reference 1 Source, 3-16 Reference 2 Source and 3-17 Reference 3 Source define up to three different reference signals. The sum of these reference signals defines the actual reference.
[0]	No function	
[1]	Analog Input 53	
[2]	Analog Input 54	
[7]	Pulse input 29	
[8]	Pulse input 33	
[20]	Digital pot.meter	
[21]	Analog input X30/11	
[22]	Analog input X30/12	
[23]	Analog Input X42/1	
[24]	Analog Input X42/3	
[25]	Analog Input X42/5	
[29]	Analog Input X48/2	
[30]	Ext. Closed-loop 1	
[31]	Ext. Closed-loop 2	
[32]	Ext. Closed-loop 3	

NOTICE!

This parameter cannot be adjusted while the motor is running.

3-19 Jog Speed [RPM]		
Range:	Function:	
Size related*	[0 - par. 4-13 RPM]	Enter a value for the jog speed n_{JOG} , which is a fixed output speed. The adjustable frequency drive runs at this speed when the jog function is activated. The maximum limit is defined in 4-13 Motor Speed High Limit [RPM]. See also 3-80 Jog Ramp Time.

3.5.3 3-4* Ramp 1

Configure the ramp parameter, ramping times, for each of the two ramps (parameter group 3-4* and parameter group 3-5*).

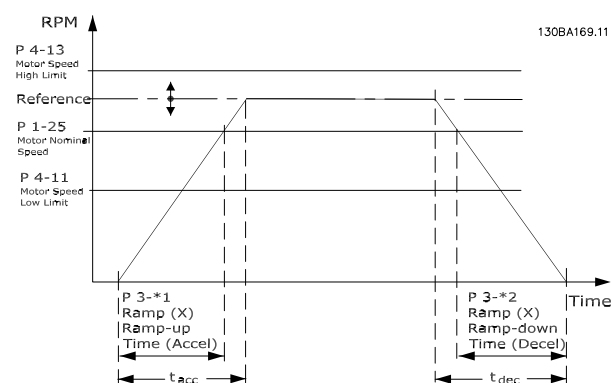

Figure 3.16

3-41 Ramp 1 Ramp-up Time		
Range:	Function:	
Size related*	[1.00 - 3600 s]	Enter the ramp-up time, i.e., the acceleration time from 0 RPM to 1-25 Motor Nominal Speed. Choose a ramp-up time such that the output current does not exceed the current limit in 4-18 Current Limit during ramping. See ramp-down time in 3-42 Ramp 1 Ramp-down Time.

$$par.3 - 41 = \frac{t_{acc} \times n_{nom} [par.1 - 25]}{ref [rpm]} [s]$$

3-42 Ramp 1 Ramp-down Time		
Range:	Function:	
Size related*	[1.00 - 3600 s]	Enter the ramp-down time, i.e., the deceleration time from 1-25 Motor Nominal Speed to 0 RPM. Choose a ramp-down time such that no overvoltage arises in the inverter due to regenerative operation of the motor, and such that the generated current does not exceed the current limit set in 4-18 Current Limit. See ramp-up time in 3-41 Ramp 1 Ramp-up Time.

$$par.3 - 42 = \frac{t_{dec} \times n_{nom} [par.1 - 25]}{ref [rpm]} [s]$$

3.5.4 3-5* Ramp 2

Choosing ramp parameters, see parameter group 3-4*.

3-51 Ramp 2 Ramp-up Time		
Range:	Function:	
Size related* [1.00 - 3600 s]	Enter the ramp-up time, i.e., the acceleration time from 0 RPM to 1-25 Motor Nominal Speed. Choose a ramp-up time such that the output current does not exceed the current limit in 4-18 Current Limit during ramping. See ramp-down time in 3-52 Ramp 2 Ramp-down Time.	
$par. 3 - 51 = \frac{t_{acc} \times n_{nom} [par. 1 - 25]}{ref [rpm]} [s]$		

3-52 Ramp 2 Ramp-down Time		
Range:	Function:	
Size related* [1.00 - 3600 s]	Enter the ramp-down time, i.e., the deceleration time from 1-25 Motor Nominal Speed to 0 RPM. Choose a ramp-down time such that no overvoltage arises in the inverter due to regenerative operation of the motor, and such that the generated current does not exceed the current limit set in 4-18 Current Limit. See ramp-up time in 3-51 Ramp 2 Ramp-up Time.	
$par. 3 - 52 = \frac{t_{dec} \times n_{nom} [par. 1 - 25]}{ref [rpm]} [s]$		

3.5.5 3-8* Other Ramps

3-80 Jog Ramp Time		
Range:	Function:	
Size related* [1 - 3600 s]	Enter the jog ramp time, i.e., the acceleration/ deceleration time between 0 RPM and the rated motor speed (n _{M,N}) (set in 1-25 Motor Nominal Speed). Ensure that the resultant output current required for the given jog ramp time does not exceed the current limit in 4-18 Current Limit. The jog ramp time starts upon activation of a jog signal via the control panel, a selected digital input, or the serial communication port.	
$par. 3 - 80 = \frac{t_{jog} \times n_{nom} [par. 1 - 25]}{jog\ speed [par. 3 - 19]} [s]$		

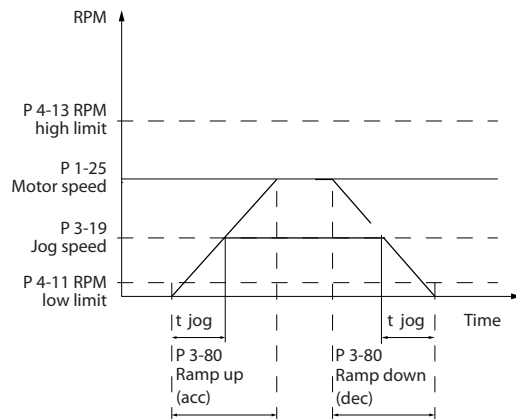

Figure 3.17

3-84 Initial Ramp Time		
Range:	Function:	
0 s* [0 - 60 s]	Enter the initial ramp-up time from zero speed to Motor Speed Low Limit, 4-11 Motor Speed Low Limit [RPM] or 4-12 Motor Speed Low Limit [Hz]. Submersible deep well pumps can be damaged by running below minimum speed. A fast ramp time below minimum pump speed is recommended. This parameter may be applied as a fast ramp rate from zero speed to Motor Speed Low Limit. See Figure 3.18.	

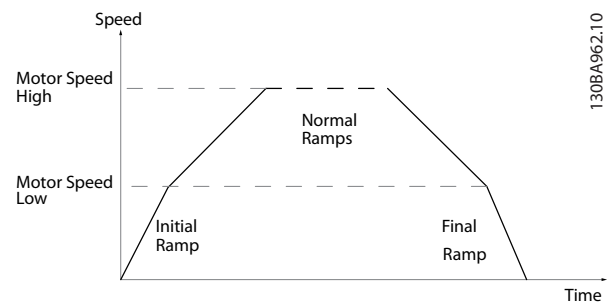

Figure 3.18 Initial and Final Ramp Time

3-85 Check Valve Ramp Time		
Range:	Function:	
0 s* [0 - 60 s]	In order to protect ball check valves in a stop situation, the check valve ramp can be utilized as a slow ramp rate from 4-11 Motor Speed Low Limit [RPM] or 4-12 Motor Speed Low Limit [Hz], to Check Valve Ramp End Speed, set by the user in 3-86 Check Valve Ramp End Speed [RPM] or 3-87 Check Valve Ramp End Speed [HZ]. When 3-85 Check Valve Ramp Time is different from 0 seconds, the Check Valve Ramp Time is effectuated and will be used to ramp down the speed from	

3-85 Check Valve Ramp Time		
Range:	Function:	
	Motor Speed Low Limit to the Check Valve End Speed in 3-86 Check Valve Ramp End Speed [RPM] or 3-87 Check Valve Ramp End Speed [HZ]. See Figure 3.19.	

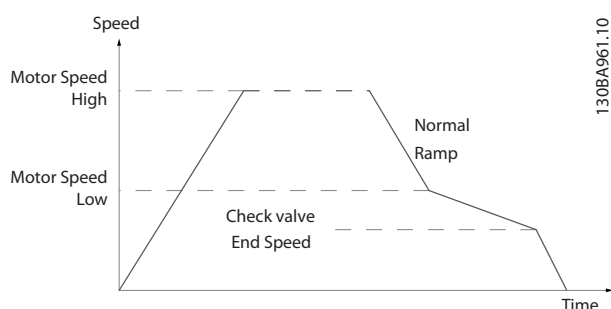

Figure 3.19 Check Valve Ramp

3-86 Check Valve Ramp End Speed [RPM]		
Range:	Function:	
Size related*	[0 - par. 4-11 RPM]	Set the speed in [RPM] below Motor Speed Low Limit where the Check Valve is expected to be closed and the Check Valve no longer shall be active. See Figure 3.19.

3-87 Check Valve Ramp End Speed [HZ]		
Range:	Function:	
Size related*	[0 - par. 4-12 Hz]	Set the speed in [Hz] below Motor Speed Low Limit where the Check Valve Ramp will no longer be active. See Figure 3.19.

3-88 Final Ramp Time		
Range:	Function:	
0 s*	[0 - 60 s]	Enter the Final Ramp Time to be used when ramping down from Motor Speed Low Limit, 4-11 Motor Speed Low Limit [RPM] or 4-12 Motor Speed Low Limit [Hz], to zero speed. Submersible deep well pumps can be damaged by running below minimum speed. A fast ramp time below minimum pump speed is recommended. This parameter may be applied as a fast ramp rate from Motor Speed Low Limit to zero speed. See Figure 3.18.

3.5.6 3-9* Digital Pot.Meter

The digital potentiometer function allows the user to increase or decrease the actual reference by adjusting the set-up of the digital inputs using the functions INCREASE, DECREASE or CLEAR. To activate the function, at least one digital input must be set up to INCREASE or DECREASE.

3-90 Step Size		
Range:	Function:	
0.10 %*	[0.01 - 200 %]	

3-91 Ramp Time		
Range:	Function:	
1 s	[0 - 3600 s]	Enter the ramp time, i.e., the time for adjustment of the reference from 0% to 100% of the specified digital potentiometer function (INCREASE, DECREASE or CLEAR). If INCREASE/DECREASE is activated for longer than the ramp delay period specified in 3-95 Ramp Delay, the actual reference will be ramped up/down according to this ramp time. The ramp time is defined as the time used to adjust the reference by the step size specified in 3-90 Step Size.

3-92 Power Restore		
Option:	Function:	
[0]	Off	Resets the Digital Potentiometer reference to 0% after power-up.
[1]	On	Restores the most recent Digital Potentiometer reference at power-up.

3-93 Maximum Limit		
Range:	Function:	
100 %*	[-200 - 200 %]	Set the maximum permissible value for the resultant reference. This is advisable if the Digital Potentiometer is used for fine tuning of the resulting reference.

3-94 Minimum Limit		
Range:	Function:	
0 %*	[-200 - 200 %]	

3-95 Ramp Delay		
Range:		Function:
Size related*	[0.000 - 0.000]	Enter the delay required from activation of the digital potentiometer function until the adjustable frequency drive starts to ramp the reference. With a delay of 0 ms, the reference starts to ramp as soon as INCREASE/DECREASE is activated. See also 3-91 Ramp Time.

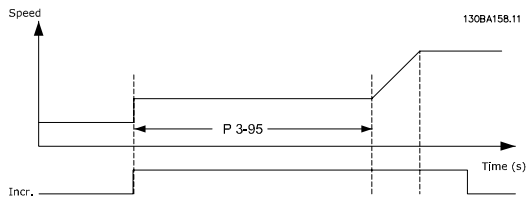

Figure 3.20

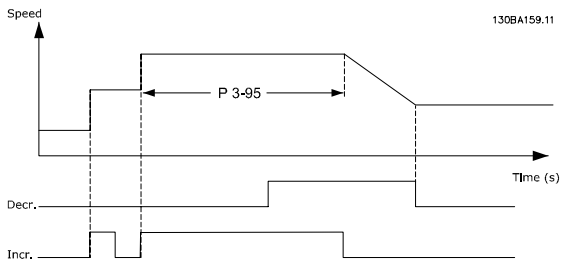

Figure 3.21

3.6 Parameters 4-** Limits/Warnings

3.6.1 4-** Limits and Warnings

Parameter group for configuring limits and warnings.

3.6.2 4-1* Motor Limits

Define torque, current and speed limits for the motor, and the reaction of the adjustable frequency drive when the limits are exceeded.

A limit may generate a message on the display. A warning will always generate a message on the display or on the serial communication bus. A monitoring function may initiate a warning or a trip, upon which the adjustable frequency drive will stop and generate an alarm message.

4-10 Motor Speed Direction		
Option:	Function:	
		Selects the motor speed direction required. When 1-00 Configuration Mode is set to [3] Closed-loop, the parameter default is changed to [0] Clockwise. If both directions are chosen, running in counter-clockwise cannot be chosen from the LCP.
[0]	Clockwise	
[2]	Both directions	

4-11 Motor Speed Low Limit [RPM]		
Range:	Function:	
Size related*	[0 - par. 4-13 RPM]	Enter the minimum limit for motor speed. The Motor Speed Low Limit can be set to correspond to the manufacturer's recommended minimum motor speed. The Motor Speed Low Limit must not exceed the setting in 4-13 Motor Speed High Limit [RPM].

4-12 Motor Speed Low Limit [Hz]		
Range:	Function:	
Size related*	[0 - par. 4-14 Hz]	Enter the minimum limit for motor speed. The Motor Speed Low Limit can be set to correspond to the minimum output frequency of the motor shaft. The Speed Low Limit must not exceed the setting in 4-14 Motor Speed High Limit [Hz].

4-13 Motor Speed High Limit [RPM]		
Range:	Function:	
Size related*	[par. 4-11 - 60000 RPM]	Enter the maximum limit for motor speed. The Motor Speed High Limit can be set to correspond to the manufacturer's maximum rated motor. The Motor Speed High Limit must exceed the setting in 4-11 Motor Speed Low Limit [RPM]. Only 4-11 Motor Speed Low Limit [RPM] or 4-12 Motor Speed Low Limit [Hz] will be displayed, depending on other parameters in the main menu, and depending on default settings dependant on global location.

NOTICE!

Max. output frequency cannot exceed 10% of the inverter switching frequency (14-01 Switching Frequency).

NOTICE!

Any changes in 4-13 Motor Speed High Limit [RPM] will reset the value in 4-53 Warning Speed High to the same value as set in 4-13 Motor Speed High Limit [RPM].

4-14 Motor Speed High Limit [Hz]		
Range:	Function:	
Size related*	[par. 4-12 - par. 4-19 Hz]	Enter the maximum limit for motor speed. The Motor Speed High Limit can be set to correspond to the manufacturer's recommended maximum of the motor shaft. The Motor Speed High Limit must exceed the in 4-12 Motor Speed Low Limit [Hz]. Only 4-13 Motor Speed High Limit [RPM] or 4-14 Motor Speed High Limit [Hz] will be displayed, depending on other parameters in the main menu, and depending on default settings dependant on global location.

NOTICE!

Max. output frequency cannot exceed 10% of the inverter switching frequency (14-01 Switching Frequency).

4-16 Torque Limit Motor Mode		
Range:	Function:	
Size related*	[0 - 1000.0 %]	

4-17 Torque Limit Generator Mode		
Range:	Function:	
100 %*	[0 - 1000.0 %]	

4-18 Current Limit		
Range:	Function:	
Size related* [1.0 - 1000.0 %]	Enter the current limit for motor and generator operation. To protect the motor from reaching the stalling torque, the default setting is 1.1 x the rated motor torque (calculated value). If a setting in 1-00 Configuration Mode to 1-26 Motor Cont. Rated Torque is changed, 4-18 Current Limit is not automatically reset to the default setting.	

4-19 Max Output Frequency		
Range:	Function:	
Size related* [1 - 1000.0 Hz]	Enter the maximum output frequency value. 4-19 Max Output Frequency specifies the absolute limit on the adjustable frequency drive output frequency for improved safety in applications where accidental overspeeding must be avoided. This absolute limit applies to all configurations and is independent of the setting in 1-00 Configuration Mode. This parameter cannot be adjusted while the motor is running.	

NOTICE!

When 1-10 Motor Construction is set to [1] PM, non-salient SPM, the maximum value is limited to 300 Hz

3.6.3 4-5* Adj. Warnings

Define adjustable warning limits for current, speed, reference and feedback.

NOTICE!

Not visible in display, only in MCT 10 Set-up Software.

Warnings are shown on display, programmed output or serial bus.

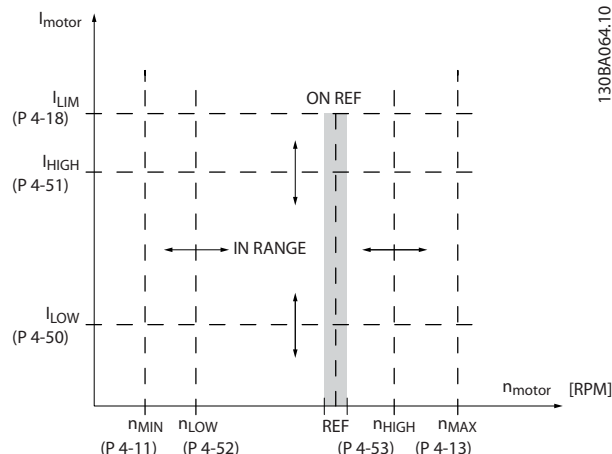

Figure 3.22

4-50 Warning Current Low		
Range:	Function:	
0 A* [0 - par. 4-51 A]	Enter the I _{LOW} value. When the motor current falls below this limit (I _{LOW}), the display reads CURRENT LOW. The signal outputs can be programmed to produce a status signal on terminal 27 or 29 and on relay output 01 or 02. Refer to Figure 3.22.	

4-51 Warning Current High		
Range:	Function:	
Size related* [par. 4-50 - par. 16-37 A]	Enter the I _{HIGH} value. When the motor current exceeds this limit (I _{HIGH}), the display reads CURRENT HIGH. The signal outputs can be programmed to produce a status signal on terminal 27 or 29 and on relay output 01 or 02. Refer to Figure 3.22.	

4-52 Warning Speed Low		
Range:	Function:	
0 RPM* [0 - par. 4-53 RPM]	Enter the n _{LOW} value. When the motor speed falls below this limit (n _{LOW}), the display reads SPEED LOW. The signal outputs can be programmed to produce a status signal on terminal 27 or 29 and on relay output 01 or 02. Program the lower signal limit of the motor speed, n _{LOW} , within the normal working range of the adjustable frequency drive. Refer to the drawing in this section.	

4-53 Warning Speed High		
Range:		Function:
Size related*	[par. 4-52 - par. 4-13 RPM]	Enter the n_{HIGH} value. When the motor speed exceeds this limit (n_{HIGH}), the display reads SPEED HIGH. The signal outputs can be programmed to produce a status signal on terminal 27 or 29 and on relay output 01 or 02. Program the upper signal limit of the motor speed, n_{HIGH} , within the normal working range of the adjustable frequency drive. Refer to Figure 3.22.

NOTICE!

Any changes in 4-13 Motor Speed High Limit [RPM] will reset the value in 4-53 Warning Speed High to the same value as set in 4-13 Motor Speed High Limit [RPM].

If a different value is needed in 4-53 Warning Speed High, it must be set after programming of 4-13 Motor Speed High Limit [RPM]

4-54 Warning Reference Low		
Range:		Function:
-999999.999 *	[-999999.999 - par. 4-55]	Enter the lower reference limit. When the actual reference falls below this limit, the display indicates Ref _{Low} . The signal outputs can be programmed to produce a status signal on terminal 27 or 29 and on relay output 01 or 02.

4-55 Warning Reference High		
Range:		Function:
999999.999 *	[par. 4-54 - 999999.999]	Enter the upper reference limit. When the actual reference exceeds this limit, the display reads Ref _{High} . The signal outputs can be programmed to produce a status signal on terminal 27 or 29 and on relay output 01 or 02.

4-56 Warning Feedback Low		
Range:		Function:
-999999.999 ProcessCtrlUnit*	[-999999.999 - par. 4-57 ProcessCtrlUnit]	Enter the lower feedback limit. When the feedback falls below this limit, the display reads Feedb _{Low} . The signal outputs can be programmed to produce a status signal on terminal

4-56 Warning Feedback Low		
Range:		Function:
		27 or 29 and on relay output 01 or 02.

4-57 Warning Feedback High		
Range:		Function:
999999.999 ProcessCtrlUnit*	[par. 4-56 - 999999.999 ProcessCtrlUnit]	Enter the upper feedback limit. When the feedback exceeds this limit, the display reads Feedb _{High} . The signal outputs can be programmed to produce a status signal on terminal 27 or 29 and on relay output 01 or 02.

4-58 Missing Motor Phase Function		
Option:	Function:	
		Displays an alarm in the event of a missing motor phase.
[0]	Disabled	No alarm is displayed if a missing motor phase occurs.

NOTICE!

This parameter cannot be adjusted while the motor is running.

3.6.4 4-6* Speed Bypass

Some systems call for avoiding certain output frequencies or speeds due to resonance problems in the system. A maximum of four frequency or speed ranges can be avoided.

4-60 Bypass Speed From [RPM]		
Array [4]		
Range:		Function:
Size related*	[0 - par. 4-13 RPM]	Some systems call for avoiding certain output speeds due to resonance problems in the system. Enter the lower limits of the speeds to be avoided.

4-61 Bypass Speed From [Hz]		
Array [4]		
Range:		Function:
Size related*	[0 - par. 4-14 Hz]	Some systems call for avoiding certain output speeds due to resonance problems in the system. Enter the lower limits of the speeds to be avoided.

4-62 Bypass Speed to [RPM]		
Array [4]		
Range:		Function:
Size related*	[0 - par. 4-13 RPM]	Some systems call for avoiding certain output speeds due to resonance problems in the system. Enter the upper limits of the speeds to be avoided.

4-63 Bypass Speed To [Hz]		
Array [4]		
Range:		Function:
Size related*	[0 - par. 4-14 Hz]	Some systems call for avoiding certain output speeds due to resonance problems in the system. Enter the upper limits of the speeds to be avoided.

Repeat the above procedure when speed is leaving the resonance bands during the deceleration. The actual frequencies registered when pressing *OK* will be stored in *4-60 Bypass Speed From [RPM]* or *4-61 Bypass Speed From [Hz]*.

- When the motor has ramped down to stop, press *OK*. The *4-64 Semi-Auto Bypass Set-up* will automatically reset to *Off*. The adjustable frequency drive will stay in *Hand* mode until *Off* or *Auto On* are pressed on the LCP.

If the frequencies for a certain resonance band are not registered in the right order (frequency values stored in *By Pass Speed To* are higher than those in *By Pass Speed From*) or if they do not have the same numbers of registrations for the *By Pass From* and *By Pass To*, all registrations will be cancelled and the following message is displayed: *Collected speed areas overlapping or not completely determined. Press [Cancel] to abort.*

4-64 Semi-Auto Bypass Set-up		
Option:	Function:	
[0]	OFF	No function
[1]	Enabled	Start the Semi-Automatic Bypass set-up and continue with the procedure described above.

3.6.5 Semi-Automatic Bypass Speed Set-up

The Semi-Automatic Bypass Speed Set-up can be used to facilitate the programming of the frequencies to be skipped due to resonances in the system.

Carry out following process

- Stop the motor.
- Select *Enabled* in *4-64 Semi-Auto Bypass Set-up*.
- Press *Hand On* on the LCP to start the search for frequency bands causing resonances. The motor will ramp up according to the ramp set.
- When sweeping through a resonance band, press *OK* on the LCP when leaving the band. The actual frequency will be stored as the first element in *4-62 Bypass Speed to [RPM]* or *4-63 Bypass Speed To [Hz]* (array). Repeat this for each resonance band identified at the ramp-up (maximum four can be adjusted).
- When maximum speed has been reached, the motor will automatically begin to ramp down.

3.7 Parameters 5-** Digital In/Out

Parameter group for configuring the digital input and output.

3.7.1 5-0* Digital I/O Mode

Parameters for configuring the input and output using NPN and PNP.

5-00 Digital I/O Mode		
Option:	Function:	
		Digital inputs and programmed digital outputs are pre-programmable for operation either in PNP or NPN systems.
[0]	PNP - Active at 24 V	Action on positive directional pulses (0). PNP systems are pulled down to GND.
[1]	NPN - Active at 0V	Action on negative directional pulses (1). NPN systems are pulled up to +24 V, internally in the adjustable frequency drive.

NOTICE!

This parameter cannot be adjusted while the motor is running.

5-01 Terminal 27 Mode		
Option:	Function:	
[0]	Input	Defines terminal 27 as a digital input.
[1]	Output	Defines terminal 27 as a digital output.

NOTICE!

This parameter cannot be adjusted while the motor is running.

5-02 Terminal 29 Mode		
Option:	Function:	
[0]	Input	Defines terminal 29 as a digital input.
[1]	Output	Defines terminal 29 as a digital output.

NOTICE!

This parameter cannot be adjusted while the motor is running.

3.7.2 5-1* Digital Inputs

Parameters for configuring the input functions for the input terminals.

The digital inputs are used for selecting various functions in the adjustable frequency drive. All digital inputs can be set to the following functions:

Digital input function	Select	Terminal
No operation	[0]	All *term 32, 33, 29, 19
Reset	[1]	All
Coast inverse	[2]	All * term 27
Coast and reset inverse	[3]	All
DC brake inverse	[5]	All
Stop inverse	[6]	All
External interlock	[7]	All
Start	[8]	All
Latched start	[9]	All
Reversing	[10]	All
Start reversing	[11]	All
Jog	[14]	All
Preset reference on	[15]	All
Preset ref bit 0	[16]	All
Preset ref bit 1	[17]	All
Preset ref bit 2	[18]	All
Freeze reference	[19]	All
Freeze output	[20]	All
Speed up	[21]	All
Slow	[22]	All
Set-up select bit 0	[23]	All
Set-up select bit 1	[24]	All
Pulse input	[32]	term 29, 33
Ramp bit 0	[34]	All
Mains failure inverse	[36]	All
Hand/Auto Start	[51]	All
Run Permissive	[52]	All
Hand start	[53]	All
Auto start	[54]	All
DigiPot increase	[55]	All
DigiPot decrease	[56]	All
DigiPot Clear	[57]	All
Counter A (up)	[60]	29, 33
Counter A (down)	[61]	29, 33
Reset Counter A	[62]	All
Counter B (up)	[63]	29, 33
Counter B (down)	[64]	29, 33
Reset Counter B	[65]	All
Sleep Mode	[66]	All
Reset Maintenance Word	[78]	All
PTC Card 1	[80]	All
Latched Pump Derag	[85]	All
Lead Pump Start	[120]	All
Lead Pump Alternation	[121]	All
Pump 1 Interlock	[130]	All
Pump 2 Interlock	[131]	All
Pump 3 Interlock	[132]	All

Table 3.11

All = Terminals 18, 19, 27, 29, 32, X30/2, X30/3, X30/4. X30/ are the terminals on MCB 101.

Functions dedicated to only one digital input are stated in the associated parameter.

All digital inputs can be programmed to these functions:

[0]	No operation	No reaction to signals transmitted to terminal.
[1]	Reset	Resets adjustable frequency drive after a TRIP/ALARM. Not all alarms can be reset.
[2]	Coast inverse	Leaves motor in free mode. Logic '0' ⇒ coasting stop. (Default Digital input 27): Coasting stop, inverted input (NC).
[3]	Coast and reset inverse	Reset and coasting stop Inverted input (NC). Leaves motor in free mode and resets the adjustable frequency drive. Logic '0' ⇒ coasting stop and reset.
[5]	DC brake inverse	Inverted input for DC braking (NC). Stops motor by energizing it with a DC current for a certain time period. See 2-01 DC Brake Current to 2-03 DC Brake Cut-in Speed [RPM]. The function is only active when the value in 2-02 DC Braking Time is different from 0. Logic '0' ⇒ DC braking. This selection is not possible when 1-10 Motor Construction is set to [1] PM, non-salient SPM
[6]	Stop inverse	Stop Inverted function. Generates a stop function when the selected terminal goes from logical level '1' to '0'. The stop is performed according to the selected ramp time (3-42 Ramp 1 Ramp-down Time and 3-52 Ramp 2 Ramp-down Time). NOTICE! When the adjustable frequency drive is at the torque limit and has received a stop command, it may not stop by itself. To ensure that the adjustable frequency drive stops, configure a digital output to [27] Torque limit & stop and connect this digital output to a digital input that is configured as coast.
[7]	External Interlock	Same function as Coasting stop, inverse, but External Interlock generates the alarm message 'external fault' on the display when the terminal which is programmed for Coast Inverse is logic '0'. The alarm message will also be active via digital outputs and relay outputs, if programmed

		for External Interlock. The alarm can be reset using a digital input or the [Reset] key if the cause for the External Interlock has been removed. A delay can be programmed in 22-00 External Interlock Delay. After applying a signal to the input, the reaction described above will be delayed with the time set in 22-00 External Interlock Delay.																																				
[8]	Start	Select start for a start/stop command. Logic '1' = start, logic '0' = stop. (Default Digital input 18)																																				
[9]	Latched start	Motor starts, if a pulse is applied for min. 2 ms. Motor stops when Stop inverse is activated																																				
[10]	Reversing	Changes direction of motor shaft rotation. Select Logic '1' to reverse. The reversing signal only changes the direction of rotation. It does not activate the start function. Select both directions in 4-10 Motor Speed Direction. (Default Digital input 19).																																				
[11]	Start reversing	Used for start/stop and for reversing on the same wire. Signals on start are not allowed at the same time.																																				
[14]	Jog	Used for activating jog speed. See 3-11 Jog Speed [Hz]. (Default Digital input 29)																																				
[15]	Preset reference on	Used for shifting between external reference and preset reference. It is assumed that [1] External/preset has been selected in 3-04 Reference Function. Logic '0' = external reference active; logic '1' = one of the eight preset references is active.																																				
[16]	Preset ref bit 0	Enables a choice between one of the eight preset references according to Table 3.12.																																				
[17]	Preset ref bit 1	Enables a choice between one of the eight preset references according to Table 3.12.																																				
[18]	Preset ref bit 2	Enables a choice between one of the eight preset references according to Table 3.12.																																				
<table border="1" style="width: 100%; border-collapse: collapse;"> <thead> <tr> <th style="text-align: left;">Preset ref. bit</th> <th style="text-align: center;">2</th> <th style="text-align: center;">1</th> <th style="text-align: center;">0</th> </tr> </thead> <tbody> <tr> <td>Preset ref. 0</td> <td style="text-align: center;">0</td> <td style="text-align: center;">0</td> <td style="text-align: center;">0</td> </tr> <tr> <td>Preset ref. 1</td> <td style="text-align: center;">0</td> <td style="text-align: center;">0</td> <td style="text-align: center;">1</td> </tr> <tr> <td>Preset ref. 2</td> <td style="text-align: center;">0</td> <td style="text-align: center;">1</td> <td style="text-align: center;">0</td> </tr> <tr> <td>Preset ref. 3</td> <td style="text-align: center;">0</td> <td style="text-align: center;">1</td> <td style="text-align: center;">1</td> </tr> <tr> <td>Preset ref. 4</td> <td style="text-align: center;">1</td> <td style="text-align: center;">0</td> <td style="text-align: center;">0</td> </tr> <tr> <td>Preset ref. 5</td> <td style="text-align: center;">1</td> <td style="text-align: center;">0</td> <td style="text-align: center;">1</td> </tr> <tr> <td>Preset ref. 6</td> <td style="text-align: center;">1</td> <td style="text-align: center;">1</td> <td style="text-align: center;">0</td> </tr> <tr> <td>Preset ref. 7</td> <td style="text-align: center;">1</td> <td style="text-align: center;">1</td> <td style="text-align: center;">1</td> </tr> </tbody> </table> <p style="text-align: center;">Table 3.12 Preset Ref. Bit</p>			Preset ref. bit	2	1	0	Preset ref. 0	0	0	0	Preset ref. 1	0	0	1	Preset ref. 2	0	1	0	Preset ref. 3	0	1	1	Preset ref. 4	1	0	0	Preset ref. 5	1	0	1	Preset ref. 6	1	1	0	Preset ref. 7	1	1	1
Preset ref. bit	2	1	0																																			
Preset ref. 0	0	0	0																																			
Preset ref. 1	0	0	1																																			
Preset ref. 2	0	1	0																																			
Preset ref. 3	0	1	1																																			
Preset ref. 4	1	0	0																																			
Preset ref. 5	1	0	1																																			
Preset ref. 6	1	1	0																																			
Preset ref. 7	1	1	1																																			
[19]	Freeze ref	Freezes actual reference. The frozen reference is now the point of enable/																																				

		condition for Speed up and Slow to be used. If Speed up/down is used, the speed change always follows ramp 2 (3-51 Ramp 2 Ramp-up Time and 3-52 Ramp 2 Ramp-down Time) in the range 0 - 3-03 Maximum Reference Maximum Reference.			start running the motor, both conditions must be fulfilled. If Run Permissive is programmed on multiple terminals, Run permissive needs only be logic '1' on one of the terminals for the function to be carried out. The digital output signal for Run Request ([8] Start, [14] Jog or [20] Freeze output) programmed in parameter group 5-3* Digital outputs, or parameter group 5-4* Relays, will not be affected by Run Permissive.
[20]	Freeze output	Freezes actual motor frequency (Hz). The frozen motor frequency is now the point of enable/condition for Speed up and Slow to be used. If Speed up/down is used, the speed change always follows ramp 2 (3-51 Ramp 2 Ramp-up Time and 3-52 Ramp 2 Ramp-down Time) in the range 0 - 1-23 Motor Frequency. NOTICE! When Freeze output is active, the adjustable frequency drive cannot be stopped via a low 'start [13]' signal. Stop the adjustable frequency drive via a terminal programmed for [2] Coast inverse or [3] Coast and reset, inverse.		[53]	Hand start A signal applied will put the adjustable frequency drive into Hand mode as if [Hand On] has been pressed and a normal stop command will be overridden. If disconnecting the signal, the motor will stop. To make any other start commands valid, another digital input must be assigned to Auto-Start and a signal applied to this. [Hand On] and [Auto On] have no impact. [Off] will override Hand Start and Auto Start. Press either [Hand On] or [Auto On] to make Hand Start and Auto Start active again. If no signal on either Hand Start or Auto-Start, the motor will stop regardless of any normal Start command applied. If signal applied to both Hand Start and Auto-Start, the function will be Auto-Start. If [Off] is pressed, the motor will stop regardless of signals on Hand Start and Auto Start.
[21]	Speed up	For when digital control of the up/down speed is desired (motor potentiometer). Activate this function by selecting either Freeze reference or Freeze output. When Speed up is activated for less than 400 msec. the resulting reference will be increased by 0.1%. If Speed up is activated for more than 400 msec., the resulting reference will ramp according to Ramp 1 in 3-41 Ramp 1 Ramp-up Time.		[54]	Auto start A signal applied will put the adjustable frequency drive into Auto mode as if [Auto On] has been pressed. See also [53] Hand Start.
[22]	Slow	Same as [21] Speed up.		[55]	DigiPot increase Uses the input as an INCREASE signal to the Digital Potentiometer function described in parameter group 3-9*
[23]	Set-up select bit 0	Selects one of the four set-ups. Set 0-10 Active Set-up to Multi Set-up.		[56]	DigiPot decrease Uses the input as a DECREASE signal to the Digital Potentiometer function described in parameter group 3-9*
[24]	Set-up select bit 1	Same as [23] Set-up select bit 0. (Default Digital input 32)		[57]	DigiPot Clear Uses the input to CLEAR the Digital Potentiometer reference described in parameter group 3-9*
[32]	Pulse input	Select Pulse input when using a pulse sequence as either reference or feedback. Scaling is done in parameter group 5-5*.		[60]	Counter A (up) (Terminal 29 or 33 only) Input for increment counting in the SLC counter.
[34]	Ramp bit 0	Select which ramp to use. Logic "0" will select ramp 1 while logic "1" will select ramp 2.		[61]	Counter A (down) (Terminal 29 or 33 only) Input for decrement counting in the SLC counter.
[36]	Mains failure inverse	Activates 14-10 Mains Failure. Line failure inverse is active in the Logic "0" situation.		[62]	Reset Counter A Input for reset of counter A.
[51]	Hand/Auto Start	Selects Hand or Auto Start. High = Auto On only, Low = Hand on only.		[63]	Counter B (up) (Terminal 29 and 33 only) Input for increment counting in the SLC counter.
[52]	Run Permissive	The input terminal, for which the Run permissive has been programmed must be logic "1" before a start command can be accepted. Run permissive has a logic 'AND' function related to the terminal which is programmed for [8] Start, [14] Jog or [20] Freeze Output, which means that in order to		[64]	Counter B (down) (Terminal 29 and 33 only) Input for decrement counting in the SLC counter.

[65]	Reset Counter B	Input for reset of counter B.
[66]	Sleep Mode	Forces adjustable frequency drive into Sleep Mode (see parameter group 22-4*, <i>Sleep Mode</i>). Reacts on the rising edge of signal applied!
[78]	Reset Preventive Maintenance Word	Resets all data in <i>16-96 Maintenance Word</i> to 0.
[80]	PTC Card1	All digital inputs can be set to [80] <i>PTC Card 1</i> . However, only one digital input must be set to this choice.
[85]	Latched Pump Derag	Starts deragging.

The setting options below are all related to the cascade controller. Wiring diagrams and settings for parameter, see parameter group 25-** for more details.

[120]	Lead Pump Start	Starts/stops the lead pump (controlled by the adjustable frequency drive). A start requires that also a System Start signal has been applied, e.g., to one of the digital inputs set for [8] Start!
[121]	Lead Pump Alternation	Forces alternation of the lead pump in a cascade controller. <i>Lead Pump Alternation, 25-50 Lead Pump Alternation</i> must be set to either [2] <i>At Command</i> or [3] <i>At Staging or At Command</i> . <i>25-51 Alternation Event</i> can be set to any of the four options.
[130 - 138]	Pump1 Interlock - Pump9 Interlock	The function depends on the setting in <i>25-06 Number Of Pumps</i> . If set to [0] <i>No</i> , then Pump1 refers to the pump controlled by relay RELAY1, etc. If set to [1] <i>Yes</i> , Pump1 refers to the pump controlled by the adjustable frequency drive only (without any of the built-in relays involved) and Pump2 to the pump controlled by the relay RELAY1. Variable speed pump (lead) cannot be interlocked in the basic cascade controller. See <i>Table 3.13</i>

Setting in parameter group 5-1*	Setting in <i>25-06 Number Of Pumps</i>	
	[0] No	[1] Yes
[130] Pump1 Interlock	Controlled by RELAY1 (only if not lead pump)	Adjustable frequency drive controlled (cannot be interlocked)
[131] Pump2 Interlock	Controlled by RELAY2	Controlled by RELAY1
[132] Pump3 Interlock	Controlled by RELAY3	Controlled by RELAY2
[133] Pump4 Interlock	Controlled by RELAY4	Controlled by RELAY3
[134] Pump5 Interlock	Controlled by RELAY5	Controlled by RELAY4
[135] Pump6 Interlock	Controlled by RELAY6	Controlled by RELAY5
[136] Pump7 Interlock	Controlled by RELAY7	Controlled by RELAY6
[137] Pump8 Interlock	Controlled by RELAY8	Controlled by RELAY7
[138] Pump9 Interlock	Controlled by RELAY9	Controlled by RELAY8

Table 3.13

5-10 Terminal 18 Digital Input

Option: Function:

[8] *	Start	Same options and functions as parameter group 5-1*, except for <i>Pulse input</i> .
-------	-------	---

5-11 Terminal 19 Digital Input

Option: Function:

[0] *	No operation	Same options and functions as parameter group 5-1*, except for <i>Pulse input</i> .
-------	--------------	---

5-12 Terminal 27 Digital Input

Same options and functions as parameter group 5-1*, except for *Pulse input*.

Option:	Function:	
[0]	No operation	
[1]	Reset	
[2]	Coast inverse	
[3]	Coast and reset inv	
[5]	DC brake inverse	
[6]	Stop inverse	
[7]	External interlock	
[8]	Start	
[9]	Latched start	
[10]	Reverse	
[11]	Start reverse	

5-12 Terminal 27 Digital Input		
Same options and functions as parameter group 5-1*, except for <i>Pulse input</i> .		
Option:	Function:	
[14]	Jog	
[15]	Preset reference on	
[16]	Preset ref bit 0	
[17]	Preset ref bit 1	
[18]	Preset ref bit 2	
[19]	Freeze reference	
[20]	Freeze output	
[21]	Speed up	
[22]	Slow	
[23]	Set-up select bit 0	
[24]	Set-up select bit 1	
[34]	Ramp bit 0	
[36]	Mains failure inverse	
[37]	Fire Mode	
[52]	Run permissive	
[53]	Hand start	
[54]	Auto-start	
[55]	DigiPot increase	
[56]	DigiPot decrease	
[57]	DigiPot clear	
[62]	Reset Counter A	
[65]	Reset Counter B	
[66]	Sleep Mode	
[68]	Timed Actions Disab.	
[69]	Constant OFF Actions	
[70]	Constant ON Actions	
[78]	Reset Maint. Word	
[80]	PTC Card 1	
[120]	Lead Pump Start	
[121]	Lead Pump Alternation	
[130]	Pump 1 Interlock	
[131]	Pump 2 Interlock	
[132]	Pump 3 Interlock	

5-13 Terminal 29 Digital Input		
Same options and functions as parameter 5-1*.		
Option:	Function:	
[0]	No operation	
[1]	Reset	
[2]	Coast inverse	
[3]	Coast and reset inv	
[5]	DC brake inverse	
[6]	Stop inverse	
[7]	External interlock	
[8]	Start	
[9]	Latched start	
[10]	Reverse	

5-13 Terminal 29 Digital Input		
Same options and functions as parameter 5-1*.		
Option:	Function:	
[11]	Start reverse	
[14]	Jog	
[15]	Preset reference on	
[16]	Preset ref bit 0	
[17]	Preset ref bit 1	
[18]	Preset ref bit 2	
[19]	Freeze reference	
[20]	Freeze output	
[21]	Speed up	
[22]	Slow	
[23]	Set-up select bit 0	
[24]	Set-up select bit 1	
[30]	Counter input	
[32]	Pulse input	
[34]	Ramp bit 0	
[36]	Mains failure inverse	
[37]	Fire Mode	
[52]	Run permissive	
[53]	Hand start	
[54]	Auto-start	
[55]	DigiPot increase	
[56]	DigiPot decrease	
[57]	DigiPot clear	
[60]	Counter A (up)	
[61]	Counter A (down)	
[62]	Reset Counter A	
[63]	Counter B (up)	
[64]	Counter B (down)	
[65]	Reset Counter B	
[66]	Sleep Mode	
[68]	Timed Actions Disab.	
[69]	Constant OFF Actions	
[70]	Constant ON Actions	
[78]	Reset Maint. Word	
[80]	PTC Card 1	
[120]	Lead Pump Start	
[121]	Lead Pump Alternation	
[130]	Pump 1 Interlock	
[131]	Pump 2 Interlock	
[132]	Pump 3 Interlock	

5-14 Terminal 32 Digital Input		
Option:	Function:	
[0] *	No Operation	Same options and functions as parameter group 5-1* <i>Digital Inputs</i> , except for <i>Pulse input</i> .

5-15 Terminal 33 Digital Input

Option:		Function:
[0] *	No Operation	Same options and functions as parameter group 5-1* <i>Digital Inputs</i> .

5-16 Terminal X30/2 Digital Input

Option:		Function:
[0] *	No operation	This parameter is active when option module MCB 101 is installed in the adjustable frequency drive. Same options and functions as parameter group 5-1* except for <i>Pulse input</i> [32].

5-17 Terminal X30/3 Digital Input

Option:		Function:
[0] *	No operation	This parameter is active when option module MCB 101 is installed in the adjustable frequency drive. Same options and functions as parameter group 5-1* except for <i>Pulse input</i> [32].

5-18 Terminal X30/4 Digital Input

Option:		Function:
[0] *	No operation	This parameter is active when option module MCB 101 is installed in the adjustable frequency drive. Same options and functions as parameter group 5-1* except for <i>Pulse input</i> [32].

3.7.3 5-3* Digital Outputs

Parameters for configuring the output functions for the output terminals. The 2 solid-state digital outputs are common for terminals 27 and 29. Set the I/O function for terminal 27 in *5-01 Terminal 27 Mode* and set the I/O function for terminal 29 in *5-02 Terminal 29 Mode*.

These parameters cannot be adjusted while the motor is running.

The digital outputs can be programmed with these functions:

[0]	No operation	<i>Default for all digital outputs and relay outputs</i>
[1]	Control ready	The control board receives supply voltage.
[2]	Drive ready	The adjustable frequency drive is ready for operation and applies a supply signal on the control board.
[3]	Drive ready / remote control	The adjustable frequency drive is ready for operation and is in Auto On mode.

[4]	Stand-by / no warning	The adjustable frequency drive is ready for operation. No start or stop command is been given (start/disable). There are no warnings.
[5]	Running	Motor is running.
[6]	Running / no warning	The output speed is higher than the speed set in <i>1-81 Min Speed for Function at Stop [RPM]</i> . The motor is running and there are no warnings.
[8]	Run on reference / no warning	Motor runs at reference speed.
[9]	Alarm	An alarm activates the output. There are no warnings.
[10]	Alarm or warning	An alarm or a warning activates the output.
[11]	At torque limit	The torque limit set in <i>4-16 Torque Limit Motor Mode</i> has been exceeded.
[12]	Out of current range	The motor current is outside the range set in <i>4-18 Current Limit</i> .
[13]	Below current, low	Motor current is lower than set in <i>4-50 Warning Current Low</i> .
[14]	Above current, high	Motor current is higher than set in <i>4-51 Warning Current High</i> .
[15]	Out of speed range	Output speed is outside the range set in <i>4-52 Warning Speed Low</i> and <i>4-53 Warning Speed High</i> .
[16]	Below speed, low	Output speed is lower than the setting in <i>4-52 Warning Speed Low</i> .
[17]	Above speed, high	Output speed is higher than the setting in <i>4-53 Warning Speed High</i> .
[18]	Out of feedback range	Feedback is outside the range set in <i>4-56 Warning Feedback Low</i> and <i>4-57 Warning Feedback High</i> .
[19]	Below feedback low	Feedback is below the limit set in <i>4-52 Warning Speed Low</i> .
[20]	Above feedback high	The feedback is above the limit set in <i>4-56 Warning Feedback Low</i> .
[21]	Thermal warning	The thermal warning turns on when the temperature exceeds the limit in the motor, the adjustable frequency drive, the brake resistor, or the thermistor.
[25]	Reverse	<i>Reversing. Logic '1' = relay activated, 24 V DC when CW rotation of the motor. Logic '0' = relay not activated, no signal, when CCW rotation of the motor.</i>
[26]	Bus OK	Active communication (no timeout) via the serial communication port.
[27]	Torque limit and stop	Used in performing a coasting stop and in torque limit condition. If the adjustable frequency drive has received a stop signal and is at the torque limit, the signal is Logic '0'.

[28]	Brake, no warning	The brake is active and there are no warnings.
[29]	Brake ready, no fault	The brake is ready for operation and there are no faults.
[30]	Brake fault (IGBT)	The output is Logic '1' when the brake IGBT is short-circuited. Use this function to protect the adjustable frequency drive if there is a fault on the brake modules. Use the output/relay to cut out the line voltage from the adjustable frequency drive.
[35]	External Interlock	External Interlock function has been activated via one of the digital inputs.
[40]	Out of ref range	
[41]	Below reference low	
[42]	Above reference high	
[45]	Bus Ctrl	
[46]	Bus Ctrl 1 if timeout	
[47]	Bus Ctrl 0 if timeout	
[55]	Pulse output	
[60]	Comparator 0	See parameter group 13-1*. If Comparator 0 is evaluated as TRUE, the output will go high. Otherwise, it will be low.
[61]	Comparator 1	See parameter group 13-1*. If Comparator 1 is evaluated as TRUE, the output will go high. Otherwise, it will be low.
[62]	Comparator 2	See parameter group 13-1*. If Comparator 2 is evaluated as TRUE, the output will go high. Otherwise, it will be low.
[63]	Comparator 3	See parameter group 13-1*. If Comparator 3 is evaluated as TRUE, the output will go high. Otherwise, it will be low.
[64]	Comparator 4	See parameter group 13-1*. If Comparator 4 is evaluated as TRUE, the output will go high. Otherwise, it will be low.
[65]	Comparator 5	See parameter group 13-1*. If Comparator 5 is evaluated as TRUE, the output will go high. Otherwise, it will be low.
[70]	Logic Rule 0	See parameter group 13-4*. If Logic Rule 0 is evaluated as TRUE, the output will go high. Otherwise, it will be low.

[71]	Logic Rule 1	See parameter group 13-4*. If Logic Rule 1 is evaluated as TRUE, the output will go high. Otherwise, it will be low.
[72]	Logic Rule 2	See parameter group 13-4*. If Logic Rule 2 is evaluated as TRUE, the output will go high. Otherwise, it will be low.
[73]	Logic Rule 3	See parameter group 13-4*. If Logic Rule 3 is evaluated as TRUE, the output will go high. Otherwise, it will be low.
[74]	Logic Rule 4	See parameter group 13-4*. If Logic Rule 4 is evaluated as TRUE, the output will go high. Otherwise, it will be low.
[75]	Logic Rule 5	See parameter group 13-4*. If Logic Rule 5 is evaluated as TRUE, the output will go high. Otherwise, it will be low.
[80]	SL Digital Output A	See 13-52 <i>SL Controller Action</i> . The output will go high whenever the Smart Logic Action [38] <i>Set digital out A high</i> is executed. The output will go low whenever the Smart Logic Action [32] <i>Set digital out A low</i> is executed.
[81]	SL Digital Output B	See 13-52 <i>SL Controller Action</i> . The output will go high whenever the Smart Logic Action [39] <i>Set digital out B high</i> is executed. The output will go low whenever the Smart Logic Action [33] <i>Set digital out B low</i> is executed.
[82]	SL Digital Output C	See 13-52 <i>SL Controller Action</i> . The output will go high whenever the Smart Logic Action [40] <i>Set digital out C high</i> is executed. The output will go low whenever the Smart Logic Action [34] <i>Set digital out C low</i> is executed.
[83]	SL Digital Output D	See 13-52 <i>SL Controller Action</i> . The output will go high whenever the Smart Logic Action [41] <i>Set digital out D high</i> is executed. The output will go low whenever the Smart Logic Action [35] <i>Set digital out D low</i> is executed.
[84]	SL Digital Output E	See 13-52 <i>SL Controller Action</i> . The output will go high whenever the Smart Logic Action [42] <i>Set digital out E high</i> is executed. The output will go low whenever the Smart Logic Action [36] <i>Set digital out E low</i> is executed.
[85]	SL Digital Output F	See 13-52 <i>SL Controller Action</i> . The output will go high whenever the Smart Logic Action [43] <i>Set digital out F high</i> is executed. The output will go low whenever the Smart Logic Action [37] <i>Set digital out F low</i> is executed.
[160]	No alarm	Output is high when no alarm is present.
[161]	Running reverse	The output is high when the adjustable frequency drive is running counter-

		clockwise (the logical product of the status bits 'running' AND 'reverse').
[165]	Local reference active	Output is high when 3-13 Reference Site = [2] Local or when 3-13 Reference Site = [0] Linked to hand auto at the same time as the LCP is in hand on mode.
[166]	Remote reference active	Output is high when 3-13 Reference Site [1] or Linked to hand/auto [0] while the LCP is in Auto On mode.
[167]	Start command active	Output is high when there is an active start command (i.e., [Auto On]) and a start command via digital input or bus is active, or [Hand On].
		NOTICE! All inverse Stop/Coast commands must be inactive.
[168]	Drive in hand mode	Output is high when the adjustable frequency drive is in hand on mode (as indicated by the LED light above [Hand on]).
[169]	Drive in auto mode	Output is high when the adjustable frequency drive is in Auto mode (as indicated by the LED light above [Auto on]).
[180]	Clock Fault	The clock function has been reset to default (2000-01-01) because of a power failure.
[181]	Preventive Maintenance	One or more of the preventive maintenance events programmed in 23-10 Maintenance Item has passed the time for the specified action in 23-11 Maintenance Action.
[182]	Deragging	Deragging is active.
[188]	AHF Capacitor Connect	See 5-80 AHF Cap Reconnect Delay.
[189]	External Fan Control	External fan control is active.
[190]	No-Flow	A No-Flow situation or Minimum Speed situation has been detected if enabled in Low Power Detection. 22-21 Low Power Detection, 22-22 Low Speed Detection.
[191]	Dry Pump	A dry pump condition has been detected. This function must be enabled in 22-26 Dry Pump Function.
[192]	End of Curve	Active when an end of curve condition is present.
[193]	Sleep Mode	The adjustable frequency drive/system has set to Sleep mode. See Sleep mode, parameter group 22-4*.
[194]	Broken Belt	A Broken Belt condition has been detected. This function must be enabled in 22-60 Broken Belt Function.
[195]	Bypass Valve Control	The bypass valve control (digital/relay output in the adjustable frequency drive)

is used for compressor systems to unload the compressor during start-up by using a bypass valve. After the start command is given, the bypass valve will be open until the adjustable frequency drive reaches 4-11 Motor Speed Low Limit [RPM]). After the limit has been reached the bypass valve will be closed, allowing the compressor to operate normally. This procedure will not be activated again until a new start is initiated, and the adjustable frequency drive speed is zero when receiving a start signal. Start Delay, 1-71 Start Delay can be used in order to delay the motor start. The Bypass valve control principle:

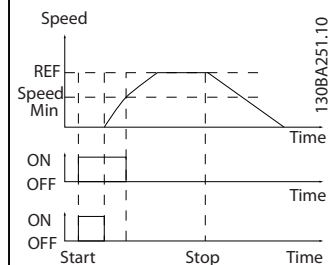

Figure 3.23

[199]	Pipe Filling	Active when the pipe fill function is operating. See parameter group 29-0*.
-------	--------------	---

The setting options below are all related to the cascade controller.

See parameter group 25-** Cascade Controller for more details.

[200]	Full Capacity	All pumps running and at full speed
[201]	Pump1 Running	One or more of the pumps controlled by the cascade controller are running. The function will also depend on the setting in 25-05 Fixed Lead Pump. If set to [0] No, Pump 1 refers to the pump controlled by relay RELAY1, etc. If set to [1] Yes, Pump 1 refers to the pump controlled by the adjustable frequency drive only (without any of the built-in relays involved) and Pump 2 to the pump controlled by the relay RELAY1. See Table 3.14
[202]	Pump2 Running	See [201]
[203]	Pump3 Running	See [201]

Setting in parameter group 5-3*	Setting in 25-05 Fixed Lead Pump	
	[0] No	[1] Yes
[201] Pump 1 Running	Controlled by RELAY1	Adjustable frequency drive controlled
[202] Pump 2 Running	Controlled by RELAY2	Controlled by RELAY1
[203] Pump 3 Running		Controlled by RELAY2

Table 3.14 Pumps Controlled by the Cascade Controller

5-30 Terminal 27 Digital Output
Option: **Function:**

[0] *	No operation	Same options and functions as parameter group 5-3*.
-------	--------------	---

5-31 Terminal 29 Digital Output
Option: **Function:**

[0] *	No operation	Same options and functions as parameter group 5-3*.
-------	--------------	---

5-32 Term X30/6 Digi Out (MCB 101)
Option: **Function:**

[0] *	No operation	This parameter is active when option module MCB 101 is mounted in the adjustable frequency drive. Same options and functions as parameter group 5-3*.
-------	--------------	---

5-33 Term X30/7 Digi Out (MCB 101)
Option: **Function:**

[0] *	No operation	This parameter is active when option module MCB 101 is mounted in the adjustable frequency drive. Same options and functions as parameter group 5-3*.
-------	--------------	---

3.7.4 5-4* Relays

Parameters for configuring the timing and the output functions for the relays.

5-40 Function Relay		
Option:	Function:	
		Select options to define the function of the relays. The selection of each mechanical relay is realized in an array parameter.
[0]	No operation	
[1]	Control ready	
[2]	Drive ready	
[3]	Drive rdy/rem ctrl	
[4]	Stand-by / no warning	

5-40 Function Relay		
Option:	Function:	
[5]	Running	
[6]	Running / no warning	
[8]	Run on ref/no warn	
[9]	Alarm	
[10]	Alarm or warning	
[11]	At torque limit	
[12]	Out of current range	
[13]	Below current, low	
[14]	Above current, high	
[15]	Out of speed range	
[16]	Below speed, low	
[17]	Above speed, high	
[18]	Out of feedb. range	
[19]	Below feedback, low	
[20]	Above feedback, high	
[21]	Thermal warning	
[25]	Reverse	
[26]	Bus OK	
[27]	Torque limit stop	
[28]	Brake: No Brake War	
[29]	Brake ready, no fault	
[30]	Brake fault (IGBT)	
[35]	External Interlock	
[36]	Control word bit 11	
[37]	Control word bit 12	
[40]	Out of ref range	
[41]	Below reference, low	
[42]	Above ref, high	
[45]	Bus ctrl.	
[46]	Bus ctrl, 1 if timeout	
[47]	Bus ctrl, 0 if timeout	
[60]	Comparator 0	
[61]	Comparator 1	
[62]	Comparator 2	
[63]	Comparator 3	
[64]	Comparator 4	
[65]	Comparator 5	
[70]	Logic rule 0	
[71]	Logic rule 1	
[72]	Logic rule 2	
[73]	Logic rule 3	
[74]	Logic rule 4	
[75]	Logic rule 5	
[80]	SL digital output A	
[81]	SL digital output B	
[82]	SL digital output C	
[83]	SL digital output D	
[84]	SL digital output E	
[85]	SL digital output F	

5-40 Function Relay	
Option:	Function:
[160]	No alarm
[161]	Running reverse
[165]	Local ref active
[166]	Remote ref active
[167]	Start command activ
[168]	Hand mode
[169]	Auto mode
[180]	Clock Fault
[181]	Prev. Maintenance
[188]	AHF Capacitor Connect
[189]	External Fan Control
[190]	No-Flow
[191]	Dry Pump
[192]	End Of Curve
[193]	Sleep Mode
[194]	Broken Belt
[195]	Bypass Valve Control
[198]	Drive Bypass
[199]	Pipe Filling
[211]	Cascade Pump 1
[212]	Cascade Pump 2
[213]	Cascade Pump 3
[214]	Cascade Pump 4
[215]	Cascade Pump 5
[216]	Cascade Pump 6
[217]	Cascade Pump 7
[218]	Cascade Pump 8
[219]	Cascade Pump 9
[230]	Ext. Cascade Ctrl

5-41 On Delay, Relay	
Range:	Function:
0.01 s*	[0.01 - 600 s]
Enter the delay of the relay cut-in time. Select one of available mechanical relays and MCB 105 in an array function. See 5-40 Function Relay. Relay 3-6 are included in MCB 113.	

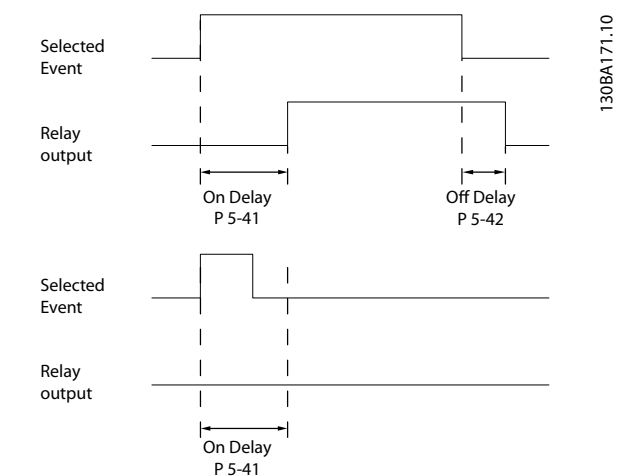

Figure 3.24

5-42 Off Delay, Relay	
Range:	Function:
0.01 s*	[0.01 - 600 s]
Enter the delay of the relay cut-out time. Select one of available mechanical relays and MCB 105 in an array function. See 5-40 Function Relay.	

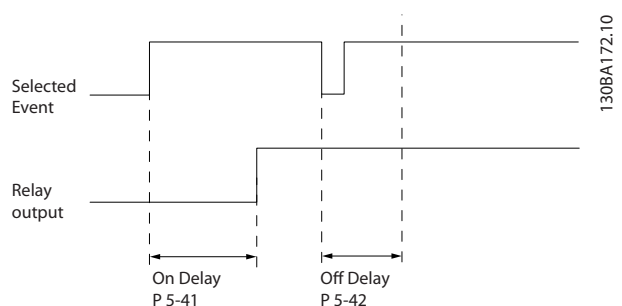

Figure 3.25

If the selected event condition changes before the on or off delay timer expires, the relay output is unaffected.

3.7.5 5-5* Pulse Input

The pulse input parameters are used to define an appropriate window for the impulse reference area by configuring the scaling and filter settings for the pulse inputs. Input terminals 29 or 33 act as frequency reference inputs. Set terminal 29 (5-13 Terminal 29 Digital Input) or terminal 33 (5-15 Terminal 33 Digital Input) to [32] Pulse input. If terminal 29 is used as an input, then set 5-02 Terminal 29 Mode to [0] Input.

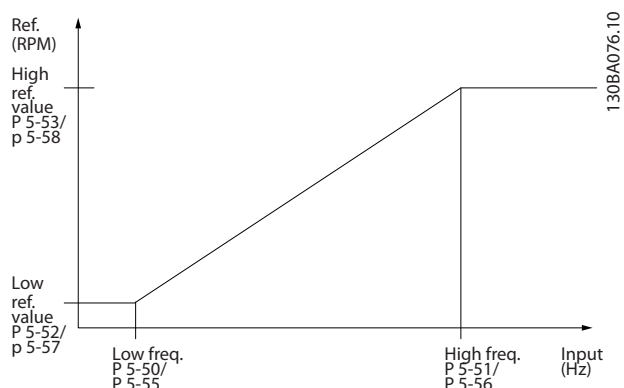

Figure 3.26

5-50 Term. 29 Low Frequency		
Range:	Function:	
100 Hz* [0 - 110000 Hz]	Enter the low frequency limit corresponding to the low motor shaft speed (i.e., low reference value) in 5-52 Term. 29 Low Ref./Feedb. Value. Refer to the diagram in this section.	

5-51 Term. 29 High Frequency		
Range:	Function:	
100 Hz* [0 - 110000 Hz]	Enter the high frequency limit corresponding to the high motor shaft speed (i.e. high reference value) in 5-53 Term. 29 High Ref./Feedb. Value.	

5-52 Term. 29 Low Ref./Feedb. Value		
Range:	Function:	
0 * [-999999.999 - 999999.999]	Enter the low reference value limit for the motor shaft speed [RPM]. This is also the lowest feedback value, see also 5-57 Term. 33 Low Ref./Feedb. Value.	

5-53 Term. 29 High Ref./Feedb. Value		
Range:	Function:	
100 * [-999999.999 - 999999.999]	Enter the high reference value [RPM] for the motor shaft speed and the high feedback value, see also 5-58 Term. 33 High Ref./Feedb. Value.	

5-54 Pulse Filter Time Constant #29		
Range:	Function:	
100 ms* [1 - 1000 ms]	Enter the pulse filter time constant. The pulse filter dampens oscillations of the feedback signal, which is an advantage if there is a lot of noise in the system. A	

5-54 Pulse Filter Time Constant #29		
Range:	Function:	
	high time constant value results in better dampening but also increases the time delay through the filter.	

NOTICE!

This parameter cannot be adjusted while the motor is running.

5-55 Term. 33 Low Frequency		
Range:	Function:	
100 Hz* [0 - 110000 Hz]	Enter the low frequency corresponding to the low motor shaft speed (i.e., low reference value) in 5-57 Term. 33 Low Ref./Feedb. Value.	

5-56 Term. 33 High Frequency		
Range:	Function:	
100 Hz* [0 - 110000 Hz]	Enter the high frequency corresponding to the high motor shaft speed (i.e., high reference value) in 5-58 Term. 33 High Ref./Feedb. Value.	

5-57 Term. 33 Low Ref./Feedb. Value		
Range:	Function:	
0 * [-999999.999 - 999999.999]	Enter the low reference value [RPM] for the motor shaft speed. This is also the low feedback value, see also 5-52 Term. 29 Low Ref./Feedb. Value.	

5-58 Term. 33 High Ref./Feedb. Value		
Range:	Function:	
100 * [-999999.999 - 999999.999]	Enter the high reference value [RPM] for the motor shaft speed. See also 5-53 Term. 29 High Ref./Feedb. Value.	

5-59 Pulse Filter Time Constant #33		
Range:	Function:	
100 ms* [1 - 1000 ms]	Enter the pulse filter time constant. The low-pass filter reduces the influence on, and dampens oscillations in, the feedback signal from the control. This is an advantage, if, for example, there is a great amount of noise in the system.	

NOTICE!

This parameter cannot be adjusted while the motor is running.

3.7.6 5-6* Pulse Outputs

Parameters for configuring the scaling and output functions of pulse outputs. The pulse outputs are designated for terminals 27 or 29. Select terminal 27 output in *5-01 Terminal 27 Mode* and terminal 29 output in *5-02 Terminal 29 Mode*.

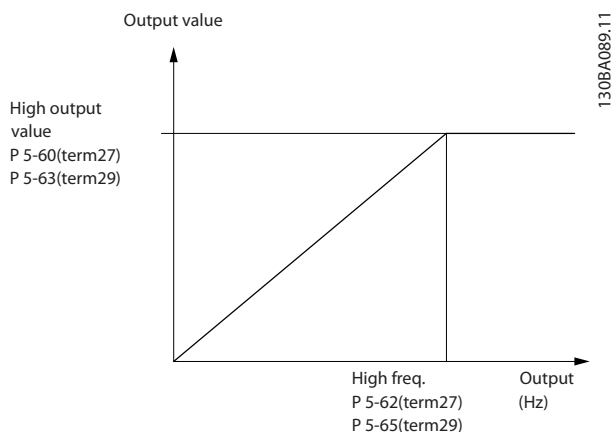

Figure 3.27

5-60 Terminal 27 Pulse Output Variable		
Option:	Function:	
[0]	No operation	Select the operation variable assigned for terminal 27 readouts. NOTICE! This parameter cannot be adjusted while the motor is running.
[45]	Bus ctrl.	
[48]	Bus ctrl., timeout	
[100]	Output freq. 0-100	
[101]	Reference Min-Max	
[102]	Feedback +-200%	
[103]	Motor cur. 0-lmax	
[104]	Torque 0-Tlim	
[105]	Torque 0-Tnom	
[106]	Power 0-Pnom	
[107]	Speed 0-HighLim	
[108]	Torque +-160%	
[109]	Out frq 0-Fmax	
[113]	Ext. Closed-loop 1	
[114]	Ext. Closed-loop 2	
[115]	Ext. Closed-loop 3	
[116]	Cascade Reference	

5-62 Pulse Output Max Freq #27		
Range:	Function:	
5000 Hz*	[0 - 32000 Hz]	Set the maximum frequency for terminal 27, corresponding to the output variable selected in <i>5-60 Terminal 27 Pulse Output Variable</i> .

NOTICE!
This parameter cannot be adjusted while the motor is running.

5-63 Terminal 29 Pulse Output Variable		
Select the variable for viewing on the terminal 29 display. Same options and functions as parameter group 5-6*.		
Option:	Function:	
[0]	No operation	
[45]	Bus ctrl.	
[48]	Bus ctrl., timeout	
[100]	Output freq. 0-100	
[101]	Reference Min-Max	
[102]	Feedback +-200%	
[103]	Motor cur. 0-lmax	
[104]	Torque 0-Tlim	
[105]	Torque 0-Tnom	
[106]	Power 0-Pnom	
[107]	Speed 0-HighLim	
[113]	Ext. Closed-loop 1	
[114]	Ext. Closed-loop 2	
[115]	Ext. Closed-loop 3	

NOTICE!
This parameter cannot be adjusted while the motor is running.

5-65 Pulse Output Max Freq #29		
Set the maximum frequency for terminal 29 corresponding to the output variable set in <i>5-63 Terminal 29 Pulse Output Variable</i> .		
Range:	Function:	
5000 Hz*	[0 - 32000 Hz]	

5-66 Terminal X30/6 Pulse Output Variable		
Select the variable for readout on terminal X30/6. This parameter is active when option module MCB 101 is installed in the adjustable frequency drive. Same options and functions as parameter group 5-6*.		
Option:	Function:	
[0]	No operation	
[45]	Bus ctrl.	
[48]	Bus ctrl., timeout	
[100]	Output freq. 0-100	

5-66 Terminal X30/6 Pulse Output Variable		
Select the variable for readout on terminal X30/6.		
This parameter is active when option module MCB 101 is installed in the adjustable frequency drive.		
Same options and functions as parameter group 5-6*.		
Option:	Function:	
[101]	Reference Min-Max	
[102]	Feedback +-200%	
[103]	Motor cur. 0-Imax	
[104]	Torque 0-Tlim	
[105]	Torque 0-Tnom	
[106]	Power 0-Pnom	
[107]	Speed 0-HighLim	
[108]	Torque +-160%	
[109]	Out frq 0-Fmax	
[113]	Ext. Closed-loop 1	
[114]	Ext. Closed-loop 2	
[115]	Ext. Closed-loop 3	
[116]	Cascade Reference	

NOTICE!

This parameter cannot be adjusted while the motor is running.

5-68 Pulse Output Max Freq #X30/6		
Select the maximum frequency on terminal X30/6 referring to the output variable in 5-66 Terminal X30/6 Pulse Output Variable.		
This parameter is active when option module MCB 101 is mounted in the adjustable frequency drive.		
Range:	Function:	
5000 Hz*	[0 - 32000 Hz]	

5-80 AHF Cap Reconnect Delay		
Range:	Function:	
25 s* [1 - 120 s]	Delay time between two consecutive AHF capacitor connections. Timer will start once AHF capacitor disconnects and will connect back once delay expires and drive power is above 20% and below 30% of nominal power (see detailed description below).	

AHF Capacitor Connect Output Function for Digital and Relay Outputs

Functional Description:

1. Connect capacitors at 20% nominal power
2. Hysteresis ±50% of the 20% nominal power (=min. 10% and max. 30% nominal power)
3. Off delay timer = 10 s. The nominal power must be below 10% for 10 s to disconnect the capacitors. If the nominal power goes above 10% during the 10 s delay, the timer (10 s) restarts.

4. The capacitor reconnect delay (default= 25 s with a range from 1 s to 120 s, see 5-80 AHF Cap Reconnect Delay) is used for the minimum off-time for the AHF Capacitor Output function.
5. In case of power loss, the adjustable frequency drive guarantees that the minimum off-time is satisfied when power is restored.

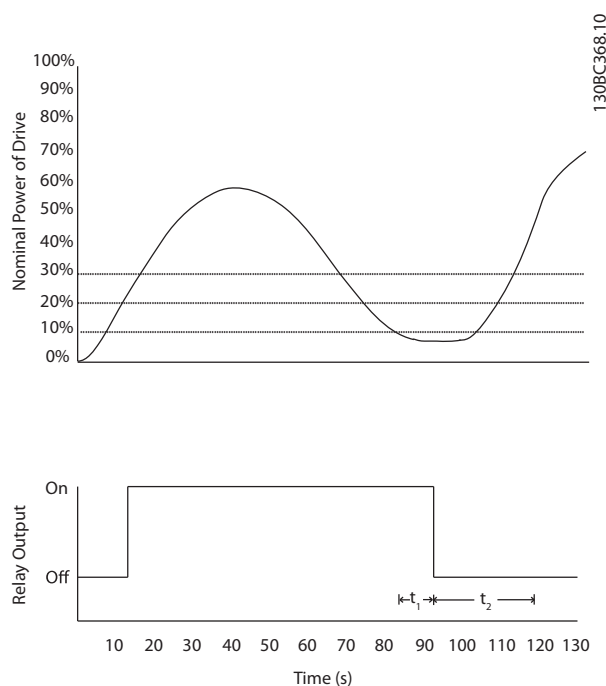

Figure 3.28 Example of the output function

t₁ represents the off delay timer (10 s).
t₂ represents the Capacitor Reconnect Delay (5-80 AHF Cap Reconnect Delay).

When the nominal power of the adjustable frequency drive exceeds 20%, the output function turns on. When the power goes below 10%, there is an Off Delay Timer that needs to expire before the output goes low; this is represented by t₁. After the output goes low, the capacitor reconnect delay timer needs to expire before the output is allowed to be on again, represented by t₂. When t₂ expires, the nominal power is above 30% and the relay does not turn on.

3.7.7 5-9* Bus Controlled

This parameter group selects digital and relay outputs via a serial communication bus setting.

5-90 Digital & Relay Bus Control																																							
Range:	Function:																																						
0 * [0 - 2147483647]	<p>This parameter holds the state of the digital outputs and relays that is controlled by bus.</p> <p>A logical '1' indicates that the output is high or active.</p> <p>A logical '0' indicates that the output is low or inactive.</p> <table border="1"> <tr><td>Bit 0</td><td>CC Digital Output Terminal 27</td></tr> <tr><td>Bit 1</td><td>CC Digital Output Terminal 29</td></tr> <tr><td>Bit 2</td><td>GPIO Digital Output Terminal X 30/6</td></tr> <tr><td>Bit 3</td><td>GPIO Digital Output Terminal X 30/7</td></tr> <tr><td>Bit 4</td><td>CC Relay 1 output terminal</td></tr> <tr><td>Bit 5</td><td>CC Relay 2 output terminal</td></tr> <tr><td>Bit 6</td><td>Option B Relay 1 output terminal</td></tr> <tr><td>Bit 7</td><td>Option B Relay 2 output terminal</td></tr> <tr><td>Bit 8</td><td>Option B Relay 3 output terminal</td></tr> <tr><td>Bit 9-15</td><td>Reserved for future terminals</td></tr> <tr><td>Bit 16</td><td>Option C Relay 1 output terminal</td></tr> <tr><td>Bit 17</td><td>Option C Relay 2 output terminal</td></tr> <tr><td>Bit 18</td><td>Option C Relay 3 output terminal</td></tr> <tr><td>Bit 19</td><td>Option C Relay 4 output terminal</td></tr> <tr><td>Bit 20</td><td>Option C Relay 5 output terminal</td></tr> <tr><td>Bit 21</td><td>Option C Relay 6 output terminal</td></tr> <tr><td>Bit 22</td><td>Option C Relay 7 output terminal</td></tr> <tr><td>Bit 23</td><td>Option C Relay 8 output terminal</td></tr> <tr><td>Bit 24-31</td><td>Reserved for future terminals</td></tr> </table> <p>Table 3.15</p>	Bit 0	CC Digital Output Terminal 27	Bit 1	CC Digital Output Terminal 29	Bit 2	GPIO Digital Output Terminal X 30/6	Bit 3	GPIO Digital Output Terminal X 30/7	Bit 4	CC Relay 1 output terminal	Bit 5	CC Relay 2 output terminal	Bit 6	Option B Relay 1 output terminal	Bit 7	Option B Relay 2 output terminal	Bit 8	Option B Relay 3 output terminal	Bit 9-15	Reserved for future terminals	Bit 16	Option C Relay 1 output terminal	Bit 17	Option C Relay 2 output terminal	Bit 18	Option C Relay 3 output terminal	Bit 19	Option C Relay 4 output terminal	Bit 20	Option C Relay 5 output terminal	Bit 21	Option C Relay 6 output terminal	Bit 22	Option C Relay 7 output terminal	Bit 23	Option C Relay 8 output terminal	Bit 24-31	Reserved for future terminals
Bit 0	CC Digital Output Terminal 27																																						
Bit 1	CC Digital Output Terminal 29																																						
Bit 2	GPIO Digital Output Terminal X 30/6																																						
Bit 3	GPIO Digital Output Terminal X 30/7																																						
Bit 4	CC Relay 1 output terminal																																						
Bit 5	CC Relay 2 output terminal																																						
Bit 6	Option B Relay 1 output terminal																																						
Bit 7	Option B Relay 2 output terminal																																						
Bit 8	Option B Relay 3 output terminal																																						
Bit 9-15	Reserved for future terminals																																						
Bit 16	Option C Relay 1 output terminal																																						
Bit 17	Option C Relay 2 output terminal																																						
Bit 18	Option C Relay 3 output terminal																																						
Bit 19	Option C Relay 4 output terminal																																						
Bit 20	Option C Relay 5 output terminal																																						
Bit 21	Option C Relay 6 output terminal																																						
Bit 22	Option C Relay 7 output terminal																																						
Bit 23	Option C Relay 8 output terminal																																						
Bit 24-31	Reserved for future terminals																																						

5-93 Pulse Out #27 Bus Control	
Range:	Function:
0 %* [0 - 100 %]	

5-94 Pulse Out #27 Timeout Preset	
Range:	Function:
0 %* [0 - 100 %]	

5-95 Pulse Out #29 Bus Control	
Range:	Function:
0 %* [0 - 100 %]	

5-96 Pulse Out #29 Timeout Preset	
Range:	Function:
0 %* [0 - 100 %]	

5-97 Pulse Out #X30/6 Bus Control	
Range:	Function:
0 %* [0 - 100 %]	

5-98 Pulse Out #X30/6 Timeout Preset	
Range:	Function:
0 %* [0 - 100 %]	

3.8 Parameters 6-** Analog In/Out

3.8.1 6-0* Analog I/O Mode

Parameter group for setting up the analog I/O configuration.

The adjustable frequency drive is equipped with 2 analog inputs: Terminal 53 and 54. The analog inputs can freely be allocated to either voltage (0–10 V) or current input (0/4–20 mA)

NOTICE!

Thermistors may be connected to either an analog or a digital input.

6-00 Live Zero Timeout Time		
Range:	Function:	
10 s* [1 - 99 s]	Enter the Live Zero Timeout time period. Live Zero Timeout Time is active for analog inputs, i.e., terminal 53 or terminal 54, used as reference or feedback sources. If the reference signal value associated with the selected current input falls below 50% of the value set in <i>6-10 Terminal 53 Low Voltage</i> , <i>6-12 Terminal 53 Low Current</i> , <i>6-20 Terminal 54 Low Voltage</i> or <i>6-22 Terminal 54 Low Current</i> for a time period longer than the time set in <i>6-00 Live Zero Timeout Time</i> , the function selected in <i>6-01 Live Zero Timeout Function</i> will be activated.	

6-01 Live Zero Timeout Function		
Option:	Function:	
	Select the Timeout function. The function set in <i>6-01 Live Zero Timeout Function</i> will be activated if the input signal on terminal 53 or 54 is below 50% of the value in <i>6-10 Terminal 53 Low Voltage</i> , <i>6-12 Terminal 53 Low Current</i> , <i>6-20 Terminal 54 Low Voltage</i> or <i>6-22 Terminal 54 Low Current</i> for a time period defined in <i>6-00 Live Zero Timeout Time</i> . If several timeouts occur simultaneously, the adjustable frequency drive prioritizes the timeout functions as follows	
	<ol style="list-style-type: none"> 1. <i>6-01 Live Zero Timeout Function</i> 2. <i>8-04 Control Timeout Function</i> 	
	The output frequency of the adjustable frequency drive can be:	
	<ul style="list-style-type: none"> • [1] frozen at the present value • [2] overruled to stop • [3] overruled to jog speed • [4] overruled to max. speed 	

6-01 Live Zero Timeout Function		
Option:	Function:	
	<ul style="list-style-type: none"> • [5] overruled to stop with subsequent trip 	
[0]	Off	
[1]	Freeze output	
[2]	Stop	
[3]	Jogging	
[4]	Max. speed	
[5]	Stop and trip	

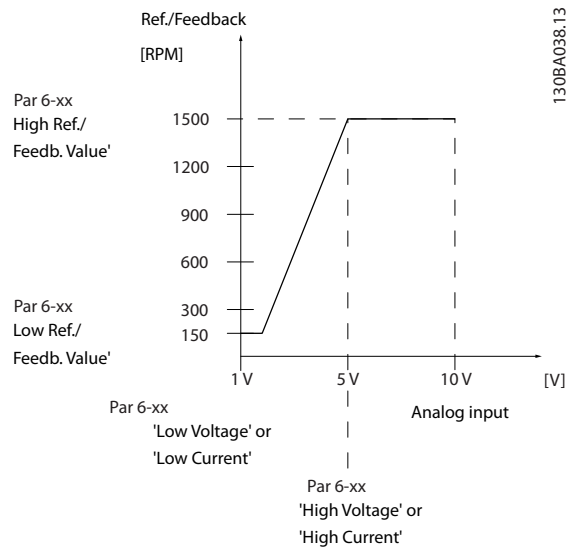

Figure 3.29

3.8.2 6-1* Analog Input 1

Parameters for configuring the scaling and limits for analog input 1 (terminal 53).

6-10 Terminal 53 Low Voltage		
Range:	Function:	
0.07 V* [0 - par. 6-11 V]	Enter the low voltage value. This analog input scaling value should correspond to the low reference/feedback value set in <i>6-14 Terminal 53 Low Ref./Feedb. Value</i> .	

6-11 Terminal 53 High Voltage		
Range:	Function:	
10 V* [par. 6-10 - 10 V]	Enter the high voltage value. This analog input scaling value should correspond to the high reference/feedback value set in <i>6-15 Terminal 53 High Ref./Feedb. Value</i> .	

6-12 Terminal 53 Low Current		
Range:	Function:	
4 mA* [0 - par. 6-13 mA]	Enter the low current value. This reference signal should correspond to the low reference/feedback value, set in 6-14 Terminal 53 Low Ref./Feedb. Value. The value must be set at >2 mA in order to activate the Live Zero Timeout Function in 6-01 Live Zero Timeout Function.	

6-13 Terminal 53 High Current		
Range:	Function:	
20 mA* [par. 6-12 - 20 mA]	Enter the high current value corresponding to the high reference/feedback set in 6-15 Terminal 53 High Ref./Feedb. Value.	

6-14 Terminal 53 Low Ref./Feedb. Value		
Range:	Function:	
0 * [-999999.999 - 999999.999]	Enter the analog input scaling value that corresponds to the low voltage/low current set in 6-10 Terminal 53 Low Voltage and 6-12 Terminal 53 Low Current.	

6-15 Terminal 53 High Ref./Feedb. Value		
Range:	Function:	
Size related* [-999999.999 - 999999.999]		

6-16 Terminal 53 Filter Time Constant		
Range:	Function:	
0.001 s* [0.001 - 10 s]	Enter the time constant. This is a first-order digital low pass filter time constant for suppressing electrical noise in terminal 53. A high time constant value improves dampening but also increases the time delay through the filter.	

NOTICE!

This parameter cannot be adjusted while the motor is running.

6-17 Terminal 53 Live Zero		
Option:	Function:	
[0] Disabled	This parameter makes it possible to disable the Live Zero monitoring and can be used, for example, if the analog outputs are used as part of a decentral I/O system (e.g., when not part of any adjustable frequency drive related control functions, but feeding an external control system with data).	

6-17 Terminal 53 Live Zero		
Option:	Function:	
[1] Enabled		

3.8.3 6-2* Analog Input 2

Parameters for configuring the scaling and limits for analog input 2 (terminal 54).

6-20 Terminal 54 Low Voltage		
Range:	Function:	
0.07 V* [0 - par. 6-21 V]	Enter the low voltage value. This analog input scaling value should correspond to the low reference/feedback value, set in 6-24 Terminal 54 Low Ref./Feedb. Value.	

6-21 Terminal 54 High Voltage		
Range:	Function:	
10 V* [par. 6-20 - 10 V]	Enter the high voltage value. This analog input scaling value should correspond to the high reference/feedback value set in 6-25 Terminal 54 High Ref./Feedb. Value.	

6-22 Terminal 54 Low Current		
Range:	Function:	
4 mA* [0 - par. 6-23 mA]	Enter the low current value. This reference signal should correspond to the low reference/feedback value, set in 6-24 Terminal 54 Low Ref./Feedb. Value. The value must be set at >2 mA to activate the Live Zero Timeout Function in 6-01 Live Zero Timeout Function.	

6-23 Terminal 54 High Current		
Range:	Function:	
20 mA* [par. 6-22 - 20 mA]	Enter the high current value corresponding to the high reference/feedback value set in 6-25 Terminal 54 High Ref./Feedb. Value.	

6-24 Terminal 54 Low Ref./Feedb. Value		
Range:	Function:	
0 * [-999999.999 - 999999.999]	Enter the analog input scaling value that corresponds to the low voltage/low current value set in 6-20 Terminal 54 Low Voltage and 6-22 Terminal 54 Low Current.	

6-25 Terminal 54 High Ref./Feedb. Value		
Range:	Function:	
100 * [-999999.999 - 999999.999]	Enter the analog input scaling value that corresponds to the high voltage/high current value set in 6-21 Terminal 54 High Voltage and 6-23 Terminal 54 High Current.	

6-26 Terminal 54 Filter Time Constant		
Range:	Function:	
0.001 s* [0.001 - 10 s]	Enter the time constant. This is a first-order digital low pass filter time constant for suppressing electrical noise in terminal 54. A high time constant value improves dampening but also increases the time delay through the filter.	

NOTICE!

This parameter cannot be adjusted while the motor is running.

6-27 Terminal 54 Live Zero		
Option:	Function:	
[0] Disabled		
[1] Enabled	This parameter makes it possible to disable the Live Zero monitoring and can be used, for example, if the analog outputs are used as part of a decentral I/O system (e.g., when not part of any adjustable frequency drive related control functions, but feeding an external control system with data).	

3.8.4 6-3* Analog Input 3 MCB 101

Parameter group for configuring the scale and limits for analog input 3 (X30/11) placed on option module MCB 101.

6-30 Terminal X30/11 Low Voltage		
Range:	Function:	
0.07 V* [0 - par. 6-31 V]	Sets the analog input scaling value to correspond to the low reference/feedback value (set in 6-34 Term. X30/11 Low Ref./Feedb. Value).	

6-31 Terminal X30/11 High Voltage		
Range:	Function:	
10 V* [par. 6-30 - 10 V]	Sets the analog input scaling value to correspond to the high reference/feedback value (set in 6-35 Term. X30/11 High Ref./Feedb. Value).	

6-34 Term. X30/11 Low Ref./Feedb. Value		
Range:	Function:	
0 * [-999999.999 - 999999.999]	Sets the analog input scaling value to correspond to the low voltage value (set in 6-30 Terminal X30/11 Low Voltage).	

6-35 Term. X30/11 High Ref./Feedb. Value		
Range:	Function:	
100 * [-999999.999 - 999999.999]	Sets the analog input scaling value to correspond to the high voltage value (set in 6-31 Terminal X30/11 High Voltage).	

6-36 Term. X30/11 Filter Time Constant		
Range:	Function:	
0.001 s* [0.001 - 10 s]	A 1 st order digital low pass filter time constant for suppressing electrical noise on terminal X30/11.	

NOTICE!

This parameter cannot be adjusted while the motor is running.

6-37 Term. X30/11 Live Zero		
Option:	Function:	
[0] Disabled		
[1] Enabled	This parameter makes it possible to disable the Live Zero monitoring and can be used, for example, if the analog outputs are used as part of a decentral I/O system (e.g., when not part of any adjustable frequency drive related control functions, but feeding an external control system with data).	

3.8.5 6-4* Analog Input 4 MCB 101

Parameter group for configuring the scale and limits for analog input 4 (X30/12) placed on option module MCB 101.

6-40 Terminal X30/12 Low Voltage		
Range:	Function:	
0.07 V* [0 - par. 6-41 V]	Sets the analog input scaling value to correspond to the low reference/feedback value set in 6-44 Term. X30/12 Low Ref./Feedb. Value.	

6-41 Terminal X30/12 High Voltage		
Range:	Function:	
10 V* [par. 6-40 - 10 V]	Sets the analog input scaling value to correspond to the high reference/ feedback value set in 6-45 Term. X30/12 High Ref./Feedb. Value.	

6-44 Term. X30/12 Low Ref./Feedb. Value		
Range:	Function:	
0 * [-999999.999 - 999999.999]	Sets the analog output scaling value to correspond to the low voltage value set in 6-40 Terminal X30/12 Low Voltage.	

6-45 Term. X30/12 High Ref./Feedb. Value		
Range:	Function:	
100 * [-999999.999 - 999999.999]	Sets the analog input scaling value to correspond to the high voltage value set in 6-41 Terminal X30/12 High Voltage.	

6-46 Term. X30/12 Filter Time Constant		
Range:	Function:	
0.001 s* [0.001 - 10 s]	A 1 st order digital low pass filter time constant for suppressing electrical noise on terminal X30/12.	

NOTICE!

This parameter cannot be adjusted while the motor is running.

6-47 Term. X30/12 Live Zero		
Option:	Function:	
	This parameter makes it possible to disable the Live Zero monitoring and can be used, for example, if the analog outputs are used as part of a decentral I/O system (e.g., when not part of any adjustable frequency drive related control functions, but feeding an external control system with data).	
[0]	Disabled	
[1]	Enabled	

3.8.6 6-5* Analog Output 1

Parameters for configuring the scaling and limits for analog output 1, i.e., Terminal 42. Analog outputs are current outputs: 0/4-20 mA. Common terminal (terminal 39) is the same terminal and has the same electrical potential for analog common and digital common connection. Resolution on analog output is 12 bit.

6-50 Terminal 42 Output		
Option:	Function:	
		Select the function of Terminal 42 as an analog current output. A motor current of 20 mA corresponds to I_{max} .
[0]	No operation	
[100]	Output freq. 0-100	: 0–100 Hz, (0–20 mA)
[101]	Reference Min-Max	Minimum reference - Maximum reference, (0–20 mA)
[102]	Feedback +-200%	-200% to +200% of 3-03 Maximum Reference, (0–20 mA)
[103]	Motor cur. 0-I _{max}	0 - Inverter Max. Current (16-37 Inv. Max. Current), (0–20 mA)
[104]	Torque 0-Tlim	0 - Torque limit (4-16 Torque Limit Motor Mode), (0–20 mA)
[105]	Torque 0-Tnom	0 - Motor rated torque, (0–20 mA)
[106]	Power 0-Pnom	0 - Motor rated power, (0–20 mA)
[107]	Speed 0-HighLim	0 - Speed High Limit (4-13 Motor Speed High Limit [RPM] and 4-14 Motor Speed High Limit [Hz]), (0–20 mA)
[113]	Ext. Closed-loop 1	0–100%, (0–20 mA)
[114]	Ext. Closed-loop 2	0–100%, (0–20 mA)
[115]	Ext. Closed-loop 3	0–100%, (0–20 mA)
[130]	Out fr 0-100 4-20	0–100 Hz
[131]	Reference 4-20mA	Minimum Reference - Maximum Reference
[132]	Feedback 4-20mA	-200% to +200% of 3-03 Maximum Reference
[133]	Motor cur. 4-20mA	0 - Inverter Max. Current (16-37 Inv. Max. Current)
[134]	Torq.0-lim 4-20mA	0 - Torque limit (4-16 Torque Limit Motor Mode)
[135]	Torq.0-nom 4-20mA	0 - Motor rated torque
[136]	Power 4-20mA	0 - Motor rated power
[137]	Speed 4-20mA	0 - Speed High Limit (and 4-14 Motor Speed High Limit [Hz])
[139]	Bus ctrl.	0–100%, (0–20 mA)
[140]	Bus ctrl. 4-20 mA	0–100%
[141]	Bus ctrl t.o.	0–100%, (0–20 mA)
[142]	Bus ctrl t.o. 4-20mA	0–100%
[143]	Ext. CL 1 4-20 mA	0–100%
[144]	Ext. CL 2 4-20 mA	0–100%
[145]	Ext. CL 3 4-20 mA	0–100%

NOTICE!

Values for setting the Minimum Reference is found in 3-02 Minimum Reference and values for maximum reference in 3-03 Maximum Reference.

6-51 Terminal 42 Output Min Scale		
Range:	Function:	
0 %*	[0 - 200 %]	

6-52 Terminal 42 Output Max Scale		
Range:	Function:	
100 %*	[0 - 200 %]	

$20 \text{ mA} / \text{desired maximum current} \times 100 \%$

i.e. $10 \text{ mA} : \frac{20 \text{ mA}}{10 \text{ mA}} \times 100 \% = 200 \%$

EXAMPLE 1:

Variable value= OUTPUT FREQUENCY, range = 0–100 Hz
 Range needed for output = 0–50 Hz
 Output signal 0 or 4mA is needed at 0 Hz (0% of range) - set 6-51 Terminal 42 Output Min Scale to 0%
 Output signal 20 mA is needed at 50 Hz (50% of range) - set 6-52 Terminal 42 Output Max Scale to 50%

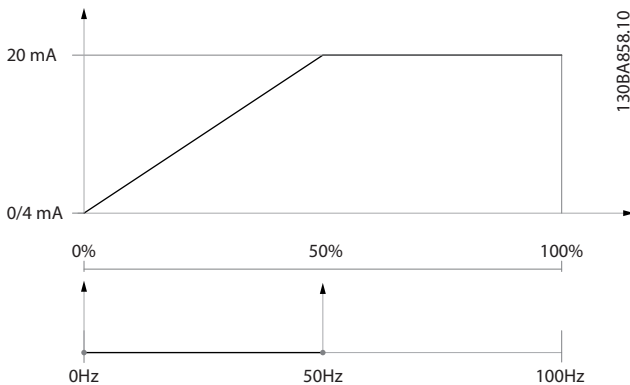

Figure 3.31

EXAMPLE 2:

Variable= FEEDBACK, range= -200% to +200%
 Range needed for output= 0–100%
 Output signal 0 or 4 mA is needed at 0% (50% of range) - set 6-51 Terminal 42 Output Min Scale to 50%
 Output signal 20 mA is needed at 100% (75% of range) - set 6-52 Terminal 42 Output Max Scale to 75%

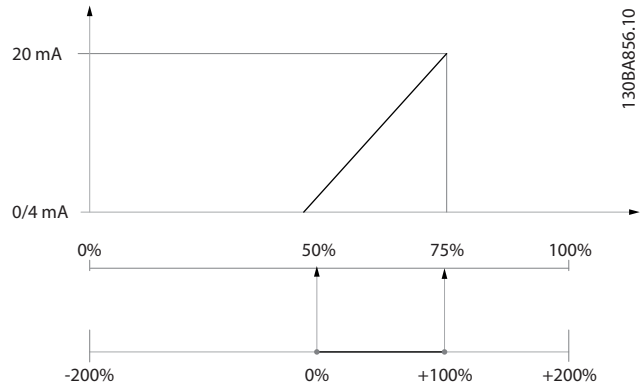

Figure 3.32

EXAMPLE 3:

Variable value= REFERENCE, range= Min ref - Max ref
 Range needed for output= Min ref (0%) - Max ref (100%), 0–10 mA
 Output signal 0 or 4 mA is needed at Min ref - set 6-51 Terminal 42 Output Min Scale to 0%
 Output signal 10 mA is needed at Max ref (100% of range) - set 6-52 Terminal 42 Output Max Scale to 200%
 (20 mA/10 mA x 100%=200%).

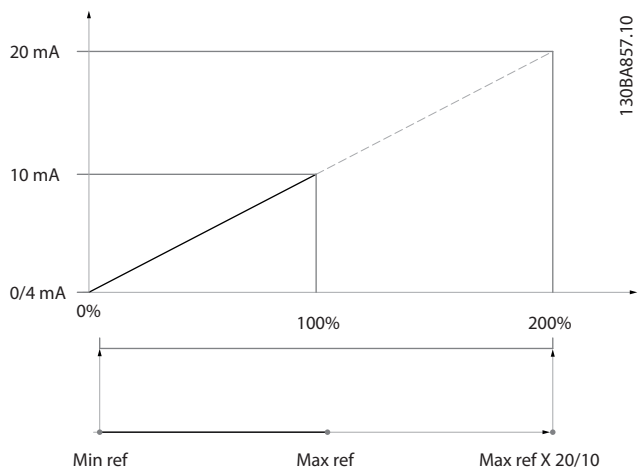

Figure 3.33

6-53 Terminal 42 Output Bus Control		
Range:	Function:	
0 %*	[0 - 100 %]	

6-54 Terminal 42 Output Timeout Preset		
Range:	Function:	
0 %*	[0 - 100 %]	

6-55 Terminal 42 Output Filter		
Option: Function:		
The following readout analog parameters from selection in <i>6-50 Terminal 42 Output</i> have a filter selected when <i>6-55 Terminal 42 Output Filter</i> is on:		
Selection	0-20 mA	4-20 mA
Motor current (0 - I _{max})	[103]	[133]
Torque limit (0 - T _{lim})	[104]	[134]
Rated torque (0 - T _{nom})	[105]	[135]
Power (0 - P _{nom})	[106]	[136]
Speed (0 - Speed _{max})	[107]	[137]
Table 3.16		
[0]	Off	Filter off
[1]	On	Filter on

3.8.7 6-6* Analog Output 2 MCB 101

Analog outputs are current outputs: 0/4–20 mA. Common terminal (terminal X30/8) is the same terminal and electrical potential for analog common connection. Resolution on analog output is 12 bit.

6-60 Terminal X30/8 Output		
Same options and functions as <i>6-50 Terminal 42 Output</i> .		
Option:		Function:
[0] *	No operation	
6-61 Terminal X30/8 Min. Scale		
Range:		Function:
0 %*	[0 - 200 %]	
6-62 Terminal X30/8 Max. Scale		
Range:		Function:
100 %*	[0 - 200 %]	
6-63 Terminal X30/8 Output Bus Control		
Range:		Function:
0 %*	[0 - 100 %]	
6-64 Terminal X30/8 Output Timeout Preset		
Range:		Function:
0 %*	[0 - 100 %]	

3.9 Parameters 8-** Communications and Options

3.9.1 8-0* General Settings

8-01 Control Site		
Option:	Function:	
		The setting in this parameter overrides the settings in <i>8-50 Coasting Select</i> to <i>8-56 Preset Reference Select</i> .
[0]	Digital and ctrl.word	Control by using both digital input and control word.
[1]	Digital only	Control by using digital inputs only.
[2]	Controlword only	Control by using control word only.

8-02 Control Source		
Option:	Function:	
		Select the source of the control word: one of two serial interfaces or four installed options. During initial power-up, the adjustable frequency drive automatically sets this parameter to [3] <i>Option A</i> if it detects a valid serial communication option installed in slot A. If the option is removed, the serial communication option detects a change in the configuration, sets <i>8-02 Control Source</i> back to default setting <i>FC Port</i> , and the adjustable frequency drive then trips. If an option is installed after initial power-up, the setting of <i>8-02 Control Source</i> will not change but the adjustable frequency drive will trip and display: Alarm 67 <i>Option Changed</i> .
		NOTICE! This parameter cannot be adjusted while the motor is running.
[0]	None	
[1]	FC RS-485	
[2]	USB Port	
[3]	Option A	
[4]	Option B	
[5]	Option C0	
[6]	Option C1	
[30]	External Can	

8-03 Control Timeout Time		
Range:	Function:	
Size related*	[1 - 18000 s]	

8-04 Control Timeout Function		
Option:	Function:	
		Select the Timeout function. The Timeout function is activated when the control word fails to be updated within the time period specified in <i>8-03 Control Timeout Time</i> . [20] <i>N2 Override Release</i> only appears after setting the <i>Metasys N2</i> protocol.
[0]	Off	
[1]	Freeze output	
[2]	Stop	
[3]	Jogging	
[4]	Max. speed	
[5]	Stop and trip	
[7]	Select setup 1	
[8]	Select setup 2	
[9]	Select setup 3	
[10]	Select setup 4	
[20]	N2 Override Release	

8-05 End-of-Timeout Function		
Option:	Function:	
		Select the action after receiving a valid control word following a timeout. This parameter is active only when <i>8-04 Control Timeout Function</i> is set to [7] <i>Set-up 1</i> , [8] <i>Set-up 2</i> , [9] <i>Set-up 3</i> or [10] <i>Set-up 4</i> .
[0]	Hold set-up	Retains the set-up selected in <i>8-04 Control Timeout Function</i> and displays a warning, until <i>8-06 Reset Control Timeout</i> toggles. Then the adjustable frequency drive resumes its original set-up.
[1]	Resume set-up	Resumes the set-up active before the timeout.

8-06 Reset Control Timeout		
Option:	Function:	
		This parameter is active only when the choice [0] <i>Hold set-up</i> has been selected in <i>8-05 End-of-Timeout Function</i> .
[0]	Do not reset	Retains the set-up specified in <i>8-04 Control Timeout Function</i> , [7] <i>Set-up 1</i> , [8] <i>Set-up 2</i> , [9] <i>Set-up 3</i> and [10] <i>Set-up 4</i> following a control timeout.
[1]	Do reset	Returns the adjustable frequency drive to the original set-up following a control word timeout. When the value is set to [1] <i>Do reset</i> , the adjustable frequency drive performs the reset and then immediately reverts to the [0] <i>Do not reset</i> setting.

8-07 Diagnosis Trigger		
Option:	Function:	
		This parameter has no function for BACnet.
[0]	Disable	
[1]	Trigger on alarms	
[2]	Trigger alarm/warn.	

8-08 Readout Filtering		
<p>If the speed feedback value readouts on the serial communication bus are fluctuating, this function is used. Select filtered if the function is required. A power-cycle is required for changes to take effect.</p>		
Option:	Function:	
[0]	Motor Data Std Filt.	Select [0] for normal bus readouts.
[1]	Motor Data LP Filter	Select [1] for filtered bus readouts of the following parameters: 16-10 Power [kW] 16-11 Power [hp] 16-12 Motor voltage 16-14 Motor current 16-16 Torque [Nm] 16-17 Speed [RPM] 16-22 Torque [%] 16-25 Torque [Nm] High

3.9.2 8-1* Ctrl. Word Settings

8-10 Control Profile		
Option:	Function:	
		Select the interpretation of the control and status words corresponding to the installed serial communication bus. Only the selections valid for the serial communication bus installed in slot A will be visible in the LPC display.
[0]	FC profile	
[1]	PROFIdrive profile	
[5]	ODVA	
[7]	CANopen DSP 402	

8-13 Configurable Status Word STW		
Option:	Function:	
		This parameter enables configuration of bits 12–15 in the status word.
[0]	No function	
[1] *	Profile Default	Function corresponds to the profile default selected in 8-10 Control Profile.

8-13 Configurable Status Word STW		
Option:	Function:	
[2]	Alarm 68 Only	Only set in case of an Alarm 68.
[3]	Trip excl. Alarm 68	Set in case of a trip, except if Alarm 68 executes the trip.
[10]	T18 DI status.	The bit indicates the status of terminal 18. "0" indicates that the terminal is low "1" indicates that the terminal is high
[11]	T19 DI status.	The bit indicates the status of terminal 19. "0" indicates that the terminal is low "1" indicates that the terminal is high
[12]	T27 DI status.	The bit indicates the status of terminal 27. "0" indicates that the terminal is low "1" indicates that the terminal is high
[13]	T29 DI status.	The bit indicates the status of terminal 29. "0" indicates that the terminal is low "1" indicates that the terminal is high
[14]	T32 DI status.	The bit indicates the status of terminal 32. "0" indicates that the terminal is low "1" indicates that the terminal is high
[15]	T33 DI status.	The bit indicates the status of terminal 33. "0" indicates that the terminal is low "1" indicates that the terminal is high
[16]	T37 DI status	The bit indicates the status of terminal 37. 0" indicates T37 is low (safe stop) "1" indicates T37 is high (normal)
[21]	Thermal warning	The thermal warning turns on when the temperature exceeds the limit in the motor, the adjustable frequency drive, the brake resistor, or the thermistor.
[30]	Brake fault (IGBT)	Output is Logic '1' when the brake IGBT is short-circuited. Use this function to protect the adjustable frequency drive if there is a fault on the brake modules. Use the output/relay to cut out the line voltage from the adjustable frequency drive.
[40]	Out of ref range	
[60]	Comparator 0	See parameter group 13-1*. If Comparator 0 is evaluated as TRUE, the output goes high. Otherwise, it is low.
[61]	Comparator 1	See parameter group 13-1*. If Comparator 1 is evaluated as TRUE, the output goes high. Otherwise, it is low.
[62]	Comparator 2	See parameter group 13-1*. If Comparator 2 is evaluated as TRUE, the output goes high. Otherwise, it is low.
[63]	Comparator 3	See parameter group 13-1*. If Comparator 3 is evaluated as TRUE, the output goes high. Otherwise, it is low.
[64]	Comparator 4	See parameter group 13-1*. If Comparator 4 is evaluated as TRUE, the output goes high. Otherwise, it is low.

8-13 Configurable Status Word STW		
Option:	Function:	
[65]	Comparator 5	See parameter group 13-1*. If Comparator 5 is evaluated as TRUE, the output goes high. Otherwise, it is low.
[70]	Logic Rule 0	See parameter group 13-4*. If Logic Rule 0 is evaluated as TRUE, the output goes high. Otherwise, it is low.
[71]	Logic Rule 1	See parameter group 13-4*. If Logic Rule 1 is evaluated as TRUE, the output goes high. Otherwise, it is low.
[72]	Logic Rule 2	See parameter group 13-4*. If Logic Rule 2 is evaluated as TRUE, the output goes high. Otherwise, it is low.
[73]	Logic Rule 3	See parameter group 13-4*. If Logic Rule 3 is evaluated as TRUE, the output goes high. Otherwise, it is low.
[74]	Logic Rule 4	See parameter group 13-4*. If Logic Rule 4 is evaluated as TRUE, the output goes high. Otherwise, it is low.
[75]	Logic Rule 5	See parameter group 13-4*. If Logic Rule 5 is evaluated as TRUE, the output goes high. Otherwise, it is low.
[80]	SL Digital Output A	See 13-52 <i>SL Controller Action</i> . The output goes high whenever the Smart Logic Action [38] <i>Set digital out A high</i> is executed. The output goes low whenever the Smart Logic Action [32] <i>Set digital out A low</i> is executed.
[81]	SL Digital Output B	See 13-52 <i>SL Controller Action</i> . The input goes high whenever the Smart Logic Action [39] <i>Set digital out B high</i> is executed. The input goes low whenever the Smart Logic Action [33] <i>Set digital out B low</i> is executed.
[82]	SL Digital Output C	See 13-52 <i>SL Controller Action</i> . The input goes high whenever the Smart Logic Action [40] <i>Set digital out C high</i> is executed. The input goes low whenever the Smart Logic Action [34] <i>Set digital out C low</i> is executed.
[83]	SL Digital Output D	See 13-52 <i>SL Controller Action</i> . The input goes high whenever the Smart Logic Action [41] <i>Set digital out D high</i> is executed. The input goes low whenever the Smart Logic Action [35] <i>Set digital out D low</i> is executed.
[84]	SL Digital Output E	See 13-52 <i>SL Controller Action</i> . The input goes high whenever the Smart Logic Action [42] <i>Set digital out E high</i> is executed. The input goes low whenever the Smart Logic Action [36] <i>Set digital out E low</i> is executed.

8-13 Configurable Status Word STW		
Option:	Function:	
[85]	SL Digital Output F	See 13-52 <i>SL Controller Action</i> . The input goes high whenever the Smart Logic Action [43] <i>Set digital out F high</i> is executed. The input goes low whenever the Smart Logic Action [37] <i>Set digital out F low</i> is executed.

8-14 Configurable Control Word CTW		
Option:	Function:	
		Selection of control word bit 10 if it is active low or active high.
[0]	None	
[1]	Profile default	
[2]	CTW valid, active low	

3.9.3 8-3* FC Port Settings

8-30 Protocol		
Option:	Function:	
		Protocol selection for the integrated FC (standard) Port (RS-485) on the control card.
[0]	FC	Communication according to the FC Protocol as described in <i>RS-485 Installation and Set-up</i> in the relevant Design Guide.
[1]	FC MC	Same as [0] FC but to be used when downloading SW to the adjustable frequency drive or uploading dll file (covering information regarding parameters available in the adjustable frequency drive and their inter-dependencies) to MCT 10 Set-up Software.
[2]	Modbus RTU	Communication according to the Modbus RTU protocol.
[3]	Metasys N2	
[9]	FC Option	

8-31 Address		
Range:	Function:	
Size related* [1 - 255]	Enter the address for the FC (standard) port. Valid range: 1-126.	

8-32 Baud Rate		
Option:	Function:	
		Baud rates 9600, 19200, 38400 and 76800 baud are valid for BACnet only.
[0]	2400 Baud	
[1]	4800 Baud	
[2]	9600 Baud	

8-32 Baud Rate	
Option:	Function:
[3] 19200 Baud	
[4] 38400 Baud	
[5] 57600 Baud	
[6] 76800 Baud	
[7] 115200 Baud	

Default refers to the FC protocol.

8-33 Parity / Stop Bits	
Option:	Function:
	Parity and Stop Bits for the protocol 8-30 Protocol using the FC Port. For some of the protocols, not all options are visible. Default depends on the protocol selected.
[0] Even Parity, 1 Stop Bit	
[1] Odd Parity, 1 Stop Bit	
[2] No Parity, 1 Stop Bit	
[3] No Parity, 2 Stop Bits	

8-35 Minimum Response Delay	
Range:	Function:
Size related*	[5 - 10000 ms]

8-36 Maximum Response Delay	
Range:	Function:
Size related*	[11 - 10001 ms]

8-37 Maximum Inter-Char Delay	
Range:	Function:
Size related* [0.00 - 35.00 ms]	Specify the maximum permissible time interval between receiving two bytes. This parameter activates timeout if transmission is interrupted.

3.9.4 8-4* Message Selection

8-40 Telegram selection	
Option:	Function:
	Enables use of freely configurable messages or standard messages for the FC port.
[1] Standard telegram 1	
[101] PPO1	
[102] PPO 2	
[103] PPO 3	
[104] PPO 4	
[105] PPO 5	
[106] PPO 6	

8-40 Telegram selection	
Option:	Function:
[107] PPO 7	
[108] PPO 8	
[200] Custom telegram 1	

8-42 PCD Write Configuration	
Option:	Function:
[0] None	Select the parameters to be assigned to PCD messages. The number of available PCDs depends on the telegram type. The values in the PCDs will then be written to the selected parameters as data values.

8-43 PCD Read Configuration	
Option:	Function:
[0] None	Select the parameters to be assigned to PCDs of the messages. The number of available PCDs depends on the message type. PCDs contain the actual data values of the selected parameters.

3.9.5 8-5* Digital/Bus

Parameters for configuring the control word Digital/Bus merging.

NOTICE!

These parameters are active only when 8-01 Control Site is set to [0] Digital and control word.

8-50 Coasting Select	
Option:	Function:
	Select control of the coasting function via the terminals (digital input) and/or via the bus.
[0] Digital input	Activates Start command via a digital input.
[1] Bus	Activates Start command via the serial communication port or serial communication option.
[2] Logic AND	Activates Start command via the serial communication bus/serial communication port, AND additionally via one of the digital inputs.
[3] Logic OR	Activates Start command via the serial communication bus/serial communication port OR via one of the digital inputs.

8-52 DC Brake Select	
Option:	Function:
	Select control of the DC brake via the terminals (digital input) and/or via the serial communication bus.

8-52 DC Brake Select		
Option:	Function:	
		NOTICE! Only selection [0] Digital Input is available when 1-10 Motor Construction is set to [1] PM, non-salient SPM
[0]	Digital input	Activates Start command via a digital input.

8-53 Start Select		
Option:	Function:	
		Select control of the adjustable frequency drive start function via the terminals (digital input) and/or via the serial communication bus.
[0]	Digital input	Activates Start command via a digital input.
[1]	Bus	Activates the start command via the serial communication port or serial communication option.
[2]	Logic AND	Activates the Start command via the serial communication bus/port, AND additionally via one of the digital inputs.
[3]	Logic OR	Activates the Start command via the serial communication bus/port OR via one of the digital inputs.

8-54 Reverse Select		
Option:	Function:	
		Select control of the adjustable frequency drive reverse function via the terminals (digital input) and/or via the serial communication bus.
[0]	Digital input	Activates Reverse command via a digital input.
[1]	Bus	Activates Reverse command via the serial communication port or serial communication option.
[2]	Logic AND	Activates Reverse command via the serial communication bus/serial communication port, AND additionally via one of the digital inputs.
[3]	Logic OR	Activates Reverse command via the serial communication bus/serial communication port OR via one of the digital inputs.

NOTICE!

This parameter is active only when 8-01 Control Site is set to [0] Digital and control word.

8-55 Set-up Select		
Option:	Function:	
		Select control of the adjustable frequency drive set-up selection via the terminals (digital input) and/or via the serial communication bus.
[0]	Digital input	Activates the set-up selection via a digital input.
[1]	Bus	Activates the set-up selection via the serial communication port or serial communication option.
[2]	Logic AND	Activates the set-up selection via the serial communication port, AND additionally via one of the digital inputs.
[3]	Logic OR	Activate the set-up selection via the serial communication port OR via one of the digital inputs.

8-56 Preset Reference Select		
Option:	Function:	
		Select control of the adjustable frequency drive Preset Reference selection via the terminals (digital input) and/or via the serial communication bus.
[0]	Digital input	Activates Preset Reference selection via a digital input.
[1]	Bus	Activates the Preset Reference selection via the serial communication port or serial communication option.
[2]	Logic AND	Activates the Preset Reference selection via the serial communication port, AND additionally via one of the digital inputs.
[3]	Logic OR	Activates the Preset Reference selection via the serial communication port OR via one of the digital inputs.

3.9.6 8-8* FC Port Diagnostics

These parameters are used for monitoring the bus communication via the FC Port.

8-80 Bus Message Count		
Range:	Function:	
0 *	[0 - 0]	This parameter shows the number of valid messages detected on the bus.

8-81 Bus Error Count		
Range:	Function:	
0 *	[0 - 0]	This parameter shows the number of telegrams with faults (e.g., CRC fault), detected on the bus.

8-82 Slave Messages Rcvd		
Range:	Function:	
0 *	[0 - 0]	This parameter shows the number of valid telegrams addressed to the slave, sent by the adjustable frequency drive.

8-83 Slave Error Count		
Range:	Function:	
0 *	[0 - 0]	This parameter shows the number of error telegrams, which could not be executed by the adjustable frequency drive.

3.9.7 8-9* Bus Jog

8-90 Bus Jog 1 Speed		
Range:	Function:	
100 RPM*	[0 - par. 4-13 RPM]	Enter the jog speed. Activate this fixed jog speed via the serial port or serial communication option.

8-91 Bus Jog 2 Speed		
Range:	Function:	
200 RPM*	[0 - par. 4-13 RPM]	Enter the jog speed. Activate this fixed jog speed via the serial port or serial communication option.

8-94 Bus Feedback 1		
Range:	Function:	
0 *	[-200 - 200]	Write a feedback to this parameter via the serial communication port or serial communication option. This parameter must be selected in <i>20-00 Feedback 1 Source</i> , <i>20-03 Feedback 2 Source</i> or <i>20-06 Feedback 3 Source</i> as a feedback source.

8-95 Bus Feedback 2		
Range:	Function:	
0 *	[-200 - 200]	See <i>8-94 Bus Feedback 1</i> for further details.

8-96 Bus Feedback 3		
Range:	Function:	
0 *	[-200 - 200]	See <i>8-94 Bus Feedback 1</i> for further details.

3.10 Parameters 9-** Profibus

For Profibus parameter descriptions, see the *Profibus Instruction Manual, MG33C*.

3.11 Parameters 10-** CAN Fieldbus

3.11.1 10-0* Common Settings

10-00 CAN Protocol		
Option:	Function:	
[1]	DeviceNet	View the active CAN protocol.

NOTICE!

The parameter options depend on installed option.

10-01 Baud Rate Select		
Option:	Function:	
		Select the serial communication bus transmission speed. The selection must correspond to the transmission speed of the master and the other serial communication bus nodes.
[20]	125 Kbps	
[21]	250 Kbps	
[22]	500 Kbps	

10-02 MAC ID		
Range:	Function:	
Size related*	[0 - 63]	

10-05 Readout Transmit Error Counter		
Range:	Function:	
0 *	[0 - 255]	View the number of CAN control transmission errors since the last power-up.

10-06 Readout Receive Error Counter		
Range:	Function:	
0 *	[0 - 255]	View the number of CAN control receipt errors since the last power-up.

10-07 Readout Bus Off Counter		
Range:	Function:	
0 *	[0 - 255]	View the number of Bus Off events since the last power-up.

3.11.2 10-1* DeviceNet

10-10 Process Data Type Selection		
Option:	Function:	
		Select the Instance (telegram) for data transmission. The instances available are dependent upon the setting of <i>8-10 Control Profile</i> . When <i>8-10 Control Profile</i> is set to [0] <i>[0] FC profile</i> , <i>10-10 Process Data Type Selection</i> options [0] <i>INSTANCE 100/150</i> and [1] <i>INSTANCE 101/151</i> are available. When <i>8-10 Control Profile</i> is set to [5] <i>ODVA</i> , <i>10-10 Process Data Type Selection</i> options [2] <i>INSTANCE 20/70</i> and [3] <i>INSTANCE 21/71</i> are available. Instances 100/150 and 101/151 are Danfoss-specific. Instances 20/70 and 21/71 are ODVA-specific AC Drive profiles. For guidelines in telegram selection, please refer to the <i>DeviceNet Instruction Manual, MG33D</i> .
[0]	INSTANCE 100/150	
[1]	INSTANCE 101/151	
[2]	INSTANCE 20/70	
[3]	INSTANCE 21/71	

NOTICE!

A change to this parameter will be executed immediately.

10-11 Process Data Config Write		
Option:	Function:	
		Select the process write data for I/O assembly instances 101/151. Elements [2] and [3] of this array can be selected. Elements [0] and [1] of the array are fixed.
[0]	None	
[302]	Minimum Reference	
[303]	Maximum Reference	
[341]	Ramp 1 Ramp-up Time	
[342]	Ramp 1 Ramp-down Time	
[351]	Ramp 2 Ramp-up Time	
[352]	Ramp 2 Ramp-down Time	
[380]	Jog Ramp Time	
[381]	Quick Stop Ramp Time	
[382]	Starting Ramp-up Time	
[411]	Motor Speed Low Limit [RPM]	
[413]	Motor Speed High Limit [RPM]	
[416]	Torque Limit Motor Mode	
[417]	Torque Limit Generator Mode	
[590]	Digital & Relay Bus Control	
[593]	Pulse Out #27 Bus Control	
[595]	Pulse Out #29 Bus Control	
[597]	Pulse Out #X30/6 Bus Control	
[653]	Terminal 42 Output Bus Control	
[663]	Terminal X30/8 Output Bus Control	
[890]	Bus Jog 1 Speed	
[891]	Bus Jog 2 Speed	
[894]	Bus Feedback 1	
[895]	Bus Feedback 2	
[896]	Bus Feedback 3	
[1680]	Fieldbus CTW 1	
[1682]	Fieldbus REF 1	

10-12 Process Data Config Read		
Option:	Function:	
		Select the process read data for I/O assembly instances 101/151. Elements [2] and [3] of this array can be selected. Elements [0] and [1] of the array are fixed.
[0]	None	
[894]	Bus Feedback 1	
[895]	Bus Feedback 2	
[896]	Bus Feedback 3	
[1500]	Operating hours	
[1501]	Running Hours	

10-12 Process Data Config Read		
Option:	Function:	
[1502]	kWh Counter	
[1600]	Control Word	
[1601]	Reference [Unit]	
[1602]	Reference [%]	
[1603]	Status Word	
[1605]	Main Actual Value [%]	
[1609]	Custom Readout	
[1610]	Power [kW]	
[1611]	Power [hp]	
[1612]	Motor voltage	
[1613]	Frequency	
[1614]	Motor current	
[1615]	Frequency [%]	
[1616]	Torque [Nm]	
[1617]	Speed [RPM]	
[1618]	Motor Thermal	
[1622]	Torque [%]	
[1626]	Power Filtered [kW]	
[1627]	Power Filtered [hp]	
[1630]	DC Link Voltage	
[1632]	Brake Energy /s	
[1633]	Brake Energy /2 min	
[1634]	Heatsink Temp.	
[1635]	Inverter Thermal	
[1638]	SL Controller State	
[1639]	Control Card Temp.	
[1650]	External Reference	
[1652]	Feedback [Unit]	
[1653]	Digi Pot Reference	
[1654]	Feedback 1 [Unit]	
[1655]	Feedback 2 [Unit]	
[1656]	Feedback 3 [Unit]	
[1660]	Digital Input	
[1661]	Terminal 53 Switch Setting	
[1662]	Analog Input 53	
[1663]	Terminal 54 Switch Setting	
[1664]	Analog Input 54	
[1665]	Analog Output 42 [mA]	
[1666]	Digital Output [bin]	
[1667]	Pulse Input #29 [Hz]	
[1668]	Pulse Input #33 [Hz]	
[1669]	Pulse Output #27 [Hz]	
[1670]	Pulse Output #29 [Hz]	
[1671]	Relay Output [bin]	
[1672]	Counter A	
[1673]	Counter B	
[1675]	Analog In X30/11	
[1676]	Analog In X30/12	
[1677]	Analog Out X30/8 [mA]	
[1684]	Comm. Option Status	

10-12 Process Data Config Read		
Option:	Function:	
[1685]	FC Port CTW 1	
[1690]	Alarm Word	
[1691]	Alarm Word 2	
[1692]	Warning Word	
[1693]	Warning Word 2	
[1694]	Ext. Status Word	
[1695]	Ext. Status Word 2	
[1696]	Maintenance Word	
[1830]	Analog Input X42/1	
[1831]	Analog Input X42/3	
[1832]	Analog Input X42/5	
[1833]	Analog Out X42/7 [V]	
[1834]	Analog Out X42/9 [V]	
[1835]	Analog Out X42/11 [V]	
[1850]	Sensorless Readout [unit]	

10-13 Warning Parameter		
Range:	Function:	
0 * [0 - 65535]	View a DeviceNet-specific warning word. One bit is assigned to every warning. Refer to the <i>DeviceNet Instruction Manual (MG33D)</i> for further information.	

Bit	Meaning
0	Bus not active
1	Explicit connection timeout
2	I/O connection
3	Retry limit reached
4	Actual is not updated
5	CAN bus off
6	I/O send error
7	Initialization error
8	No bus supply
9	Bus off
10	Error passive
11	Error warning
12	Duplicate MAC ID Error
13	RX queue overrun
14	TX queue overrun
15	CAN overrun

Table 3.17

10-14 Net Reference		
Read only from LCP		
Option:	Function:	
		Select the reference source in instance 21/71 and 20/70.
[0]	Off	Enables reference via analog/digital inputs.
[1]	On	Enables reference via the serial communication bus.

10-15 Net Control		
Read only from LCP		
Option:	Function:	
		Select the control source in Instance 21/71 and 20/70.
[0]	Off	Enables control via analog/digital inputs.
[1]	On	Enable control via the serial communication bus.

3.11.3 10-2* COS Filters

10-20 COS Filter 1		
Range:	Function:	
0 * [0 - 65535]	Enter the value for COS Filter 1 to set up the filter mask for the status word. When operating in COS (Change-Of-State), this function filters out bits in the status word that should not be sent if they change.	

10-21 COS Filter 2		
Range:	Function:	
0 * [0 - 65535]	Enter the value for COS Filter 2, to set up the filter mask for the Main Actual Value. When operating in COS (Change-Of-State), this function filters out bits in the Main Actual Value that should not be sent if they change.	

10-22 COS Filter 3		
Range:	Function:	
0 * [0 - 65535]	Enter the value for COS Filter 3, to set up the filter mask for PCD 3. When operating in COS (Change-Of-State), this function filters out bits in PCD 3 that should not be sent if they change.	

10-23 COS Filter 4		
Range:	Function:	
0 * [0 - 65535]	Enter the value for COS Filter 4 to set up the filter mask for PCD 4. When operating in COS (Change-Of-State), this function filters out bits in PCD 4 that should not be sent if they change.	

3.11.4 10-3* Parameter Access

Parameter group providing access to indexed parameters and defining programming set-up.

10-30 Array Index		
Range:	Function:	
0 *	[0 - 255]	View array parameters. This parameter is valid only when a DeviceNet serial communication bus is installed.

10-31 Store Data Values		
Option:	Function:	
		Parameter values changed via DeviceNet are not automatically stored in non-volatile memory. Use this parameter to activate a function that stores parameter values in the EEPROM non-volatile memory, so changed parameter values will be retained at power-down.
[0]	Off	Deactivates the non-volatile storage function.
[1]	Store all setups	Stores all parameter values from the active set-up in the non-volatile memory. The selection returns to [0] Off when all values have been stored.
[2]	Store all setups	Stores all parameter values for all set-ups in the non-volatile memory. The selection returns to [0] Off when all parameter values have been stored.

10-32 Devicenet Revision		
Range:	Function:	
0 *	[0 - 65535]	View the DeviceNet revision number. This parameter is used for EDS file creation.
Size related*	[0 - 65535]	

10-33 Store Always		
Option:	Function:	
[0]	Off	Deactivates non-volatile storage of data.
[1]	On	Stores parameter data received via DeviceNet in EEPROM non-volatile memory as default.

10-34 DeviceNet Product Code		
Range:	Function:	
Size related*	[0 - 65535]	

10-39 Devicenet F Parameters		
Array [1,000] No LCP access		
Range:	Function:	
0 *	[0 - 0]	This parameter is used to configure the adjustable frequency drive via DeviceNet and build the EDS file.

3.11.5 10-5* CANOpen

10-50 Process Data Config Write.		
Option:	Function:	
[0] *	None	
[302]	Minimum Reference	
[303]	Maximum Reference	
[312]	Catch up/slow-down value	
[341]	Ramp 1 Ramp-up Time	
[342]	Ramp 1 Ramp-down Time	
[351]	Ramp 2 Ramp-up Time	
[352]	Ramp 2 Ramp-down Time	
[380]	Jog Ramp Time	
[381]	Quick Stop Ramp Time	
[411]	Motor Speed Low Limit [RPM]	
[412]	Motor Speed Low Limit [Hz]	
[413]	Motor Speed High Limit [RPM]	
[414]	Motor Speed High Limit [Hz]	
[416]	Torque Limit Motor Mode	
[417]	Torque Limit Generator Mode	
[590]	Digital & Relay Bus Control	
[593]	Pulse Out #27 Bus Control	
[595]	Pulse Out #29 Bus Control	
[597]	Pulse Out #X30/6 Bus Control	
[653]	Terminal 42 Output Bus Control	
[663]	Terminal X30/8 Bus Control	
[673]	Terminal X45/1 Bus Control	
[683]	Terminal X45/3 Bus Control	
[890]	Bus Jog 1 Speed	
[891]	Bus Jog 2 Speed	
[1293]	Cable Error Length	
[1680]	Serial communication bus CTW 1	
[1682]	Serial communication bus REF 1	
[3401]	PCD 1 Write to MCO	
[3402]	PCD 2 Write to MCO	
[3403]	PCD 3 Write to MCO	
[3404]	PCD 4 Write to MCO	
[3405]	PCD 5 Write to MCO	
[3406]	PCD 6 Write to MCO	
[3407]	PCD 7 Write to MCO	
[3408]	PCD 8 Write to MCO	
[3409]	PCD 9 Write to MCO	
[3410]	PCD 10 Write to MCO	

10-51 Process Data Config Read.		
Option:	Function:	
[0] *	None	
[1472]	VLT Alarm Word	
[1473]	VLT Warning Word	
[1474]	VLT Ext. Status Word	
[1500]	Operating Hours	
[1501]	Running Hours	

10-51 Process Data Config Read.		
Option:		Function:
[1502]	kWh Counter	
[1600]	Control Word	
[1601]	Reference [Unit]	
[1602]	Reference %	
[1603]	Status Word	
[1605]	Main Actual Value [%]	
[1609]	Custom Readout	
[1610]	Power [kW]	
[1611]	Power [hp]	
[1612]	Motor Voltage	
[1613]	Frequency	
[1614]	Motor Current	
[1615]	Frequency [%]	
[1616]	Torque [Nm]	
[1617]	Speed [RPM]	
[1618]	Motor Thermal	
[1619]	KTY sensor temperature	
[1620]	Motor Angle	
[1622]	Torque [%]	
[1625]	Torque [Nm] High	
[1630]	DC Link Voltage	
[1632]	Brake Energy /s	
[1633]	Brake Energy /2 min	
[1634]	Heatsink Temp.	
[1635]	Inverter Thermal	
[1638]	SL Controller State	
[1639]	Control Card Temp.	
[1650]	External Reference	
[1651]	Pulse Reference	
[1652]	Feedback [Unit]	
[1653]	Digi Pot Reference	
[1660]	Digital Input	
[1661]	Terminal 53 Switch Setting	
[1662]	Analog Input 53	
[1663]	Terminal 54 Switch Setting	
[1664]	Analog Input 54	
[1665]	Analog Output 42 [mA]	
[1666]	Digital Output [bin]	
[1667]	Freq. Input #29 [Hz]	
[1668]	Freq. Input #33 [Hz]	
[1669]	Pulse Output #27 [Hz]	
[1670]	Pulse Output #29 [Hz]	
[1671]	Relay Output [bin]	
[1672]	Counter A	
[1673]	Counter B	
[1674]	Prec. Stop Counter	
[1675]	Analog In X30/11	
[1676]	Analog In X30/12	
[1677]	Analog Out X30/8 [mA]	

10-51 Process Data Config Read.		
Option:		Function:
[1678]	Analog Out X45/1 [mA]	
[1679]	Analog Out X45/3 [mA]	
[1684]	Comm. Option STW	
[1685]	FC Port CTW 1	
[1690]	Alarm Word	
[1691]	Alarm Word 2	
[1692]	Warning Word	
[1693]	Warning Word 2	
[1694]	Ext. Status Word	
[3421]	PCD 1 Read from MCO	
[3422]	PCD 2 Read from MCO	
[3423]	PCD 3 Read from MCO	
[3424]	PCD 4 Read from MCO	
[3425]	PCD 5 Read from MCO	
[3426]	PCD 6 Read from MCO	
[3427]	PCD 7 Read from MCO	
[3428]	PCD 8 Read from MCO	
[3429]	PCD 9 Read from MCO	
[3430]	PCD 10 Read from MCO	
[3440]	Digital Inputs	
[3441]	Digital Outputs	
[3450]	Actual Position	
[3451]	Commanded Position	
[3452]	Actual Master Position	
[3453]	Slave Index Position	
[3454]	Master Index Position	
[3455]	Curve Position	
[3456]	Track Error	
[3457]	Synchronizing Error	
[3458]	Actual Velocity	
[3459]	Actual Master Velocity	
[3460]	Synchronizing Status	
[3461]	Axis Status	
[3462]	Program Status	
[3464]	MCO 302 Status	
[3465]	MCO 302 Control	
[3470]	MCO Alarm Word 1	
[3471]	MCO Alarm Word 2	

3.12 Parameters 13-** Smart Logic Control

3.12.1 13-** Prog. Features

Smart Logic Control (SLC) is essentially a sequence of user-defined actions (see 13-52 *SL Controller Action* [x]) executed by the SLC when the associated user-defined event (see 13-51 *SL Controller Event* [x]) is evaluated as TRUE by the SLC. Events and actions are each numbered and linked together in pairs. This means that when the first event is fulfilled (attains the value TRUE), the first action is executed. After this, the conditions of the second event will be evaluated and if evaluated TRUE, the second action will be executed and so on. Only one event will be evaluated at any time. If an event is evaluated as FALSE, nothing happens (in the SLC) during the current scan interval and no other events will be evaluated. This means that when the SLC starts, it evaluates the first event (and only the first event) each scan interval. Only when the first event is evaluated TRUE, will the SLC execute the first action and start evaluating the second event. It is possible to program from 1 to 20 events and actions.

When the last event/action has been executed, the sequence starts over again from the first event/the first action. Figure 3.34 shows an example with three event/actions.

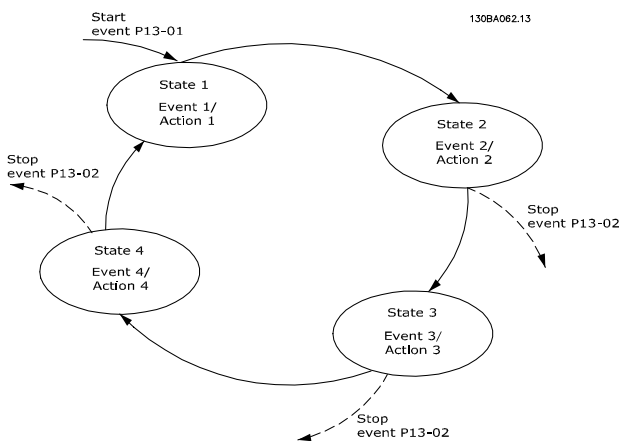

Figure 3.34

Starting and stopping the SLC

Starting and stopping the SLC can be done by selecting On [1] or Off [0] in 13-00 *SL Controller Mode*. The SLC always starts in state 0 (where it evaluates the first event). The SLC starts when the Start Event (defined in 13-01 *Start Event*) is evaluated as TRUE (provided that On [1] is selected in 13-00 *SL Controller Mode*). The SLC stops when the Stop Event (13-02 *Stop Event*) is TRUE. 13-03 *Reset SLC* resets all SLC parameters and starts programming from scratch.

3.12.2 13-0* SLC Settings

Use the SLC settings to activate, deactivate and reset the Smart Logic Control sequence. The logic functions and comparators are always running in the background, which opens for separate control of digital inputs and outputs.

13-00 SL Controller Mode		
Option:	Function:	
[0]	Off	Disables the Smart Logic Controller.
[1]	On	Enables the Smart Logic Controller.

13-01 Start Event		
Option:	Function:	
		Select the Boolean (TRUE or FALSE) input to activate Smart Logic Control.
[0]	FALSE	Enters the fixed value of FALSE in the logic rule.
[1]	TRUE	Enters the fixed value TRUE in the logic rule.
[2]	Running	See parameter group 5-3* for further description.
[3]	In range	See parameter group 5-3* for further description.
[4]	On reference	See parameter group 5-3* for further description.
[5]	Torque limit	See parameter group 5-3* for further description.
[6]	Current Limit	See parameter group 5-3* for further description.
[7]	Out of current range	See parameter group 5-3* for further description.
[8]	Below I low	See parameter group 5-3* for further description.
[9]	Above I high	See parameter group 5-3* for further description.
[10]	Out of speed range	
[11]	Below speed low	See parameter group 5-3* for further description.
[12]	Above speed high	See parameter group 5-3* for further description.
[13]	Out of feedb. range	
[14]	Below feedb. low	
[15]	Above feedb. high	
[16]	Thermal warning	See parameter group 5-3* for further description.

13-01 Start Event		
Option:	Function:	
[17]	Mains out of range	See parameter group 5-3* for further description.
[18]	Reverse	See parameter group 5-3* for further description.
[19]	Warning	See parameter group 5-3* for further description.
[20]	Alarm (trip)	See parameter group 5-3* for further description.
[21]	Alarm (trip lock)	See parameter group 5-3* for further description.
[22]	Comparator 0	Use the result of comparator 0 in the logic rule.
[23]	Comparator 1	Use the result of comparator 1 in the logic rule.
[24]	Comparator 2	Use the result of comparator 2 in the logic rule.
[25]	Comparator 3	Use the result of comparator 3 in the logic rule.
[26]	Logic rule 0	Use the result of logic rule 0 in the logic rule.
[27]	Logic rule 1	Use the result of logic rule 1 in the logic rule.
[28]	Logic rule 2	Use the result of logic rule 2 in the logic rule.
[29]	Logic rule 3	Use the result of logic rule 3 in the logic rule.
[33]	Digital input DI18	Use the value of DI18 in the logic rule (High = TRUE).
[34]	Digital input DI19	Use the value of DI19 in the logic rule (High = TRUE).
[35]	Digital input DI27	Use the value of DI27 in the logic rule (High = TRUE).
[36]	Digital input DI29	Use the value of DI29 in the logic rule (High = TRUE).
[37]	Digital input DI32	Use the value of DI32 in the logic rule (High = TRUE).
[38]	Digital input DI33	Use the value of DI33 in the logic rule (High = TRUE).
[39]	Start command	This event is TRUE if the adjustable frequency drive is started by any means (either via digital input, serial communication bus or other).
[40]	Drive stopped	This event is TRUE if the adjustable frequency drive is stopped or coasted

13-01 Start Event		
Option:	Function:	
		by any means (either via digital input, serial communication bus or other).
[41]	Reset Trip	This event is TRUE if the adjustable frequency drive is tripped (but not trip-locked) and [Reset] is pressed.
[42]	Auto Reset Trip	This event is TRUE if the adjustable frequency drive is tripped (but not trip-locked) and an automatic reset is issued.
[43]	OK key	This event is TRUE if [OK] is pressed.
[44]	Reset Key	This event is TRUE if [Reset] is pressed.
[45]	Left Key	This event is TRUE if [◀] is pressed.
[46]	Right Key	This event is TRUE if [▶] is pressed.
[47]	Up Key	This event is TRUE if [▲] is pressed.
[48]	Down Key	This event is TRUE if [▼] is pressed.
[50]	Comparator 4	Use the result of comparator 4 in the logic rule.
[51]	Comparator 5	Use the result of comparator 5 in the logic rule.
[60]	Logic rule 4	Use the result of logic rule 4 in the logic rule.
[61]	Logic rule 5	Use the result of logic rule 5 in the logic rule.
[76]	Digital Input x30 2	
[77]	Digital Input x30 3	
[78]	Digital Input x30 4	
[90]	ECB Drive Mode	
[91]	ECB Bypass Mode	
[92]	ECB Test Mode	
[100]	Fire Mode	

13-02 Stop Event		
Option:	Function:	
		Select the Boolean (TRUE or FALSE) input to deactivate Smart Logic Control.
[0]	FALSE	Enters the fixed value of FALSE in the logic rule.
[1]	TRUE	Enters the fixed value TRUE in the logic rule.
[2]	Running	See parameter group 5-3* for further description.

13-02 Stop Event		
Option:	Function:	
[3]	In range	See parameter group 5-3* for further description.
[4]	On reference	See parameter group 5-3* for further description.
[5]	Torque limit	See parameter group 5-3* for further description.
[6]	Current Limit	See parameter group 5-3* for further description.
[7]	Out of current range	See parameter group 5-3* for further description.
[8]	Below I low	See parameter group 5-3* for further description.
[9]	Above I high	See parameter group 5-3* for further description.
[10]	Out of speed range	
[11]	Below speed low	See parameter group 5-3* for further description.
[12]	Above speed high	See parameter group 5-3* for further description.
[13]	Out of feedb. range	See parameter group 5-3* for further description.
[14]	Below feedb. low	See parameter group 5-3* for further description.
[15]	Above feedb. high	See parameter group 5-3* for further description.
[16]	Thermal warning	See parameter group 5-3* for further description.
[17]	Mains out of range	See parameter group 5-3* for further description.
[18]	Reverse	See parameter group 5-3* for further description.
[19]	Warning	See parameter group 5-3* for further description.
[20]	Alarm (trip)	See parameter group 5-3* for further description.
[21]	Alarm (trip lock)	See parameter group 5-3* for further description.
[22]	Comparator 0	Use the result of comparator 0 in the logic rule.
[23]	Comparator 1	Use the result of comparator 1 in the logic rule.
[24]	Comparator 2	Use the result of comparator 2 in the logic rule.

13-02 Stop Event		
Option:	Function:	
[25]	Comparator 3	Use the result of comparator 3 in the logic rule.
[26]	Logic rule 0	Use the result of logic rule 0 in the logic rule.
[27]	Logic rule 1	Use the result of logic rule 1 in the logic rule.
[28]	Logic rule 2	Use the result of logic rule 2 in the logic rule.
[29]	Logic rule 3	Use the result of logic rule 3 in the logic rule.
[30]	SL Timeout 0	Use the result of timer 0 in the logic rule.
[31]	SL Timeout 1	Use the result of timer 1 in the logic rule.
[32]	SL Timeout 2	Use the result of timer 2 in the logic rule.
[33]	Digital input DI18	Use the value of DI18 in the logic rule (High = TRUE).
[34]	Digital input DI19	Use the value of DI19 in the logic rule (High = TRUE).
[35]	Digital input DI27	Use the value of DI27 in the logic rule (High = TRUE).
[36]	Digital input DI29	Use the value of DI29 in the logic rule (High = TRUE).
[37]	Digital input DI32	Use the value of DI32 in the logic rule (High = TRUE).
[38]	Digital input DI33	Use the value of DI33 in the logic rule (High = TRUE).
[39]	Start command	This event is TRUE if the adjustable frequency drive is started by any means (either via digital input, serial communication bus or other).
[40]	Drive stopped	This event is TRUE if the adjustable frequency drive is stopped or coasted by any means (either via digital input, serial communication bus or other).
[41]	Reset Trip	This event is TRUE if the adjustable frequency drive is tripped (but not trip-locked) and [Reset] is pressed.
[42]	Auto Reset Trip	This event is TRUE if the adjustable frequency drive is tripped (but not trip-locked) and an automatic reset is issued.
[43]	OK key	This event is TRUE if [OK] is pressed.

13-02 Stop Event		
Option:		Function:
[44]	Reset Key	This event is TRUE if [Reset] is pressed.
[45]	Left Key	This event is TRUE if [◀] is pressed.
[46]	Right Key	This event is TRUE if [▶] is pressed.
[47]	Up Key	This event is TRUE if [▲] is pressed.
[48]	Down Key	This event is TRUE if [▼] is pressed.
[50]	Comparator 4	Use the result of comparator 4 in the logic rule.
[51]	Comparator 5	Use the result of comparator 5 in the logic rule.
[60]	Logic rule 4	Use the result of logic rule 4 in the logic rule.
[61]	Logic rule 5	Use the result of logic rule 5 in the logic rule.
[70]	SL Timeout 3	Use the result of timer 3 in the logic rule.
[71]	SL Timeout 4	Use the result of timer 4 in the logic rule.
[72]	SL Timeout 5	Use the result of timer 5 in the logic rule.
[73]	SL Timeout 6	Use the result of timer 6 in the logic rule.
[74]	SL Timeout 7	Use the result of timer 7 in the logic rule.
[76]	Digital Input x30 2	
[77]	Digital Input x30 3	
[78]	Digital Input x30 4	
[80]	No Flow	
[81]	Dry Pump	
[82]	End of Curve	
[83]	Broken Belt	
[90]	ECB Drive Mode	
[91]	ECB Bypass Mode	
[92]	ECB Test Mode	
[100]	Fire Mode	

3.12.3 13-04 Comparators

Comparators are used for comparing continuous variables (i.e., output frequency, output current, analog input, etc.) to fixed preset values.

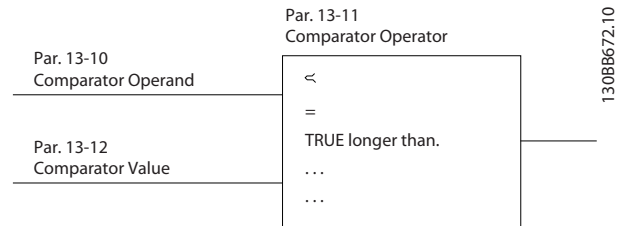

Figure 3.35

In addition, there are digital values that will be compared to fixed time values. See explanation in *13-10 Comparator Operand*. Comparators are evaluated once in each scan interval. Use the result (TRUE or FALSE) directly. All parameters in this parameter group are array parameters with index 0 to 5. Select index 0 to program Comparator 0, select index 1 to program Comparator 1, etc.

13-10 Comparator Operand		
Array [4]		
Option:		Function:
		Select the variable to be monitored by the comparator.
[0]	DISABLED	
[1]	Reference	
[2]	Feedback	
[3]	Motor speed	
[4]	Motor Current	
[5]	Motor torque	
[6]	Motor power	
[7]	Motor voltage	
[8]	DC-link voltage	
[9]	Motor Thermal	
[10]	VLT temp.	
[11]	Heat sink temp.	
[12]	Analog input AI53	
[13]	Analog input AI54	
[14]	Analog input AIFB10	
[15]	Analog input AIS24V	
[17]	Analog input AICCT	
[18]	Pulse input FI29	
[19]	Pulse input FI33	
[20]	Alarm number	
[21]	Warning number	
[22]	Analog input x30 11	
[23]	Analog input x30 12	
[24]	Sensorless Flow	
[25]	Sensorless Pressure	
[30]	Counter A	
[31]	Counter B	
[40]	Analog input x42/1	
[41]	Analog input x42/3	

13-10 Comparator Operand		
Array [4]		
Option:	Function:	
[42]	Analog input x42/5	
[50]	FALSE	
[51]	TRUE	
[52]	Control ready	
[53]	Drive ready	
[54]	Running	
[55]	Reversing	
[56]	In range	
[60]	On reference	
[61]	Below reference, low	
[62]	Above ref, high	
[65]	Torque limit	
[66]	Current Limit	
[67]	Out of current range	
[68]	Below I low	
[69]	Above I high	
[70]	Out of speed range	
[71]	Below speed low	
[72]	Above speed high	
[75]	Out of feedb. range	
[76]	Below feedback low	
[77]	Above feedback high	
[80]	Thermal warning	
[82]	Line pwr out of range	
[85]	Warning	
[86]	Alarm (trip)	
[87]	Alarm (trip lock)	
[90]	Bus OK	
[91]	Torque limit & stop	
[92]	Brake fault (IGBT)	
[93]	Mech. brake control	
[94]	Safe stop active	
[100]	Comparator 0	
[101]	Comparator 1	
[102]	Comparator 2	
[103]	Comparator 3	
[104]	Comparator 4	
[105]	Comparator 5	
[110]	Logic rule 0	
[111]	Logic rule 1	
[112]	Logic rule 2	
[113]	Logic rule 3	
[114]	Logic rule 4	
[115]	Logic rule 5	
[120]	SL Timeout 0	
[121]	SL Timeout 1	
[122]	SL Timeout 2	
[123]	SL Timeout 3	

13-10 Comparator Operand		
Array [4]		
Option:	Function:	
[124]	SL Timeout 4	
[125]	SL Timeout 5	
[126]	SL Timeout 6	
[127]	SL Timeout 7	
[130]	Digital input DI18	
[131]	Digital input DI19	
[132]	Digital input DI27	
[133]	Digital input DI29	
[134]	Digital input DI32	
[135]	Digital input DI33	
[150]	SL digital output A	
[151]	SL digital output B	
[152]	SL digital output C	
[153]	SL digital output D	
[154]	SL digital output E	
[155]	SL digital output F	
[160]	Relay 1	
[161]	Relay 2	
[180]	Local reference active	
[181]	Remote ref. active	
[182]	Start command	
[183]	Drive stopped	
[185]	Drive in hand mode	
[186]	Drive in auto mode	
[187]	Start command given	
[190]	Digital input x30 2	
[191]	Digital input x30 3	
[192]	Digital input x30 4	

13-11 Comparator Operator		
Array [6]		
Option:	Function:	
[0] <	Select [0] < for the result of the evaluation to be TRUE, when the variable selected in 13-10 Comparator Operand is smaller than the fixed value in 13-12 Comparator Value. The result will be FALSE, if the variable selected in 13-10 Comparator Operand is greater than the fixed value in 13-12 Comparator Value.	
[1] = (equal)	Select [1] ≈ for the result of the evaluation to be TRUE, when the variable selected in 13-10 Comparator Operand is approximately equal to the fixed value in 13-12 Comparator Value.	
[2] >	Select [2] > for the inverse logic of option [0] <.	
[5] TRUE longer than..		
[6] FALSE longer than..		
[7] TRUE shorter than..		
[8] FALSE shorter than..		

13-12 Comparator Value		
Array [6]		
Range:	Function:	
Size related* [-100000 - 100000]	Enter the 'trigger level' for the variable that is monitored by this comparator. This is an array parameter containing comparator values 0 to 5.	

3.12.4 13-2* Timers

Use the result (TRUE or FALSE) from *timers* directly to define an *event* (see 13-51 SL Controller Event), or as Boolean input in a *logic rule* (see 13-40 Logic Rule Boolean 1, 13-42 Logic Rule Boolean 2 or 13-44 Logic Rule Boolean 3). A timer is only FALSE when started by an action (i.e., [29] Start timer 1) until the timer value entered in this parameter is elapsed. Then it becomes TRUE again. All parameters in this parameter group are array parameters with index 0 to 2. Select index 0 to program Timer 0, select index 1 to program Timer 1, and so on.

13-20 SL Controller Timer		
Array [3]		
Range:	Function:	
Size related* [0.000 - 0.000]		

3.12.5 13-4* Logic Rules

Combine up to three Boolean inputs (TRUE/FALSE inputs) from timers, comparators, digital inputs, status bits and events using the logical operators AND, OR, and NOT. Select Boolean inputs for the calculation in 13-40 Logic Rule Boolean 1, 13-42 Logic Rule Boolean 2 and 13-44 Logic Rule Boolean 3. Define the operators used to logically combine the selected inputs in 13-41 Logic Rule Operator 1 and 13-43 Logic Rule Operator 2.

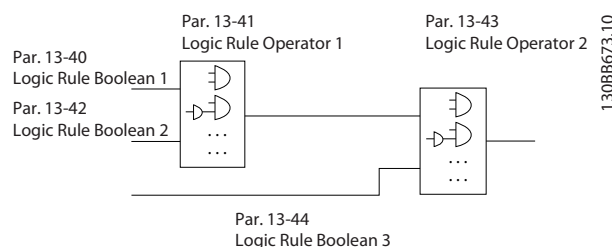

Figure 3.36

Priority of calculation

The results of 13-40 Logic Rule Boolean 1, 13-41 Logic Rule Operator 1 and 13-42 Logic Rule Boolean 2 are calculated first. The outcome (TRUE/FALSE) of this calculation is combined with the settings of 13-43 Logic Rule Operator 2 and 13-44 Logic Rule Boolean 3, yielding the final result (TRUE/FALSE) of the logic rule.

13-40 Logic Rule Boolean 1		
Array [6]		
Option:	Function:	
[0] FALSE	Enters the fixed value of FALSE in the logic rule.	
[1] TRUE	Enters the fixed value TRUE in the logic rule.	
[2] Running	See parameter group 5-3* for further description.	
[3] In range	See parameter group 5-3* for further description.	
[4] On reference	See parameter group 5-3* for further description.	
[5] Torque limit	See parameter group 5-3* for further description.	

13-40 Logic Rule Boolean 1		
Array [6]		
Option:	Function:	
[6]	Current Limit	See parameter group 5-3* for further description.
[7]	Out of current range	See parameter group 5-3* for further description.
[8]	Below I low	See parameter group 5-3* for further description.
[9]	Above I high	See parameter group 5-3* for further description.
[10]	Out of speed range	
[11]	Below speed low	See parameter group 5-3* for further description.
[12]	Above speed high	See parameter group 5-3* for further description.
[13]	Out of feedb. range	See parameter group 5-3* for further description.
[14]	Below feedb. low	See parameter group 5-3* for further description.
[15]	Above feedb. high	See parameter group 5-3* for further description.
[16]	Thermal warning	See parameter group 5-3* for further description.
[17]	Mains out of range	See parameter group 5-3* for further description.
[18]	Reverse	See parameter group 5-3* for further description.
[19]	Warning	See parameter group 5-3* for further description.
[20]	Alarm (trip)	See parameter group 5-3* for further description.
[21]	Alarm (trip lock)	See parameter group 5-3* for further description.
[22]	Comparator 0	Use the result of comparator 0 in the logic rule.
[23]	Comparator 1	Use the result of comparator 1 in the logic rule.
[24]	Comparator 2	Use the result of comparator 2 in the logic rule.
[25]	Comparator 3	Use the result of comparator 3 in the logic rule.
[26]	Logic rule 0	Use the result of logic rule 0 in the logic rule.
[27]	Logic rule 1	Use the result of logic rule 1 in the logic rule.

13-40 Logic Rule Boolean 1		
Array [6]		
Option:	Function:	
[28]	Logic rule 2	Use the result of logic rule 2 in the logic rule.
[29]	Logic rule 3	Use the result of logic rule 3 in the logic rule.
[30]	SL Timeout 0	Use the result of timer 0 in the logic rule.
[31]	SL Timeout 1	Use the result of timer 1 in the logic rule.
[32]	SL Timeout 2	Use the result of timer 2 in the logic rule.
[33]	Digital input DI18	Use the value of DI18 in the logic rule (High = TRUE).
[34]	Digital input DI19	Use the value of DI19 in the logic rule (High = TRUE).
[35]	Digital input DI27	Use the value of DI27 in the logic rule (High = TRUE).
[36]	Digital input DI29	Use the value of DI29 in the logic rule (High = TRUE).
[37]	Digital input DI32	Use the value of DI32 in the logic rule (High = TRUE).
[38]	Digital input DI33	Use the value of DI33 in the logic rule (High = TRUE).
[39]	Start command	This logic rule is TRUE if the adjustable frequency drive is started by any means (either via digital input, serial communication bus or other).
[40]	Drive stopped	This logic rule is TRUE if the adjustable frequency drive is stopped or coasted by any means (either via digital input, serial communication bus or other).
[41]	Reset Trip	This logic rule is TRUE if the adjustable frequency drive is tripped (but not trip-locked) and [Reset] is pressed.
[42]	Auto Reset Trip	This logic rule is TRUE if the adjustable frequency drive is tripped (but not trip-locked) and an automatic reset is issued.
[43]	OK key	This logic rule is TRUE if the OK key on the LCP is pressed.
[44]	Reset Key	This logic rule is TRUE if the Reset key on the LCP is pressed.

13-40 Logic Rule Boolean 1		
Array [6]		
Option:	Function:	
[45]	Left Key	This logic rule is TRUE if the Left key on the LCP is pressed.
[46]	Right Key	This logic rule is TRUE if the Right key on the LCP is pressed.
[47]	Up Key	This logic rule is TRUE if the Up key on the LCP is pressed.
[48]	Down Key	This logic rule is TRUE if the Down key on the LCP is pressed.
[50]	Comparator 4	Use the result of comparator 4 in the logic rule.
[51]	Comparator 5	Use the result of comparator 5 in the logic rule.
[60]	Logic rule 4	Use the result of logic rule 4 in the logic rule.
[61]	Logic rule 5	Use the result of logic rule 5 in the logic rule.
[70]	SL Timeout 3	Use the result of timer 3 in the logic rule.
[71]	SL Timeout 4	Use the result of timer 4 in the logic rule.
[72]	SL Timeout 5	Use the result of timer 5 in the logic rule.
[73]	SL Timeout 6	Use the result of timer 6 in the logic rule.
[74]	SL Timeout 7	Use the result of timer 7 in the logic rule.
[76]	Digital Input x30 2	
[77]	Digital Input x30 3	
[78]	Digital Input x30 4	
[80]	No Flow	
[81]	Dry Pump	
[82]	End of Curve	
[83]	Broken Belt	
[90]	ECB Drive Mode	
[91]	ECB Bypass Mode	
[92]	ECB Test Mode	
[100]	Fire Mode	

13-41 Logic Rule Operator 1		
Array [6]		
Option:	Function:	
		Select the first logical operator to use on the Boolean inputs from <i>13-40 Logic Rule Boolean 1</i> and <i>13-42 Logic Rule Boolean 2</i> .

13-41 Logic Rule Operator 1		
Array [6]		
Option:	Function:	
		[13-**] signifies the Boolean input of parameter group 13-**.
[0]	DISABLED	Ignores <i>13-42 Logic Rule Boolean 2</i> , <i>13-43 Logic Rule Operator 2</i> , and <i>13-44 Logic Rule Boolean 3</i> .
[1]	AND	Evaluates the expression [13-40] AND [13-42].
[2]	OR	Evaluates the expression [13-40] OR [13-42].
[3]	AND NOT	Evaluates the expression [13-40] AND NOT [13-42].
[4]	OR NOT	Evaluates the expression [13-40] OR NOT [13-42].
[5]	NOT AND	Evaluates the expression NOT [13-40] AND [13-42].
[6]	NOT OR	Evaluates the expression NOT [13-40] OR [13-42].
[7]	NOT AND NOT	Evaluates the expression NOT [13-40] AND NOT [13-42].
[8]	NOT OR NOT	Evaluates the expression NOT [13-40] OR NOT [13-42].

13-42 Logic Rule Boolean 2		
Array [6]		
Option:	Function:	
		Select the second Boolean (TRUE or FALSE) input for the selected logic rule. See <i>13-40 Logic Rule Boolean 1</i> for further descriptions of choices and their functions.
[0]	FALSE	
[1]	TRUE	
[2]	Running	
[3]	In range	
[4]	On reference	
[5]	Torque limit	
[6]	Current Limit	
[7]	Out of current range	
[8]	Below I low	
[9]	Above I high	
[10]	Out of speed range	
[11]	Below speed low	
[12]	Above speed high	
[13]	Out of feedb. range	
[14]	Below feedb. low	
[15]	Above feedb. high	

13-42 Logic Rule Boolean 2		
Array [6]		
Option:	Function:	
[16]	Thermal warning	
[17]	Mains out of range	
[18]	Reverse	
[19]	Warning	
[20]	Alarm (trip)	
[21]	Alarm (trip lock)	
[22]	Comparator 0	
[23]	Comparator 1	
[24]	Comparator 2	
[25]	Comparator 3	
[26]	Logic rule 0	
[27]	Logic rule 1	
[28]	Logic rule 2	
[29]	Logic rule 3	
[30]	SL Timeout 0	
[31]	SL Timeout 1	
[32]	SL Timeout 2	
[33]	Digital input DI18	
[34]	Digital input DI19	
[35]	Digital input DI27	
[36]	Digital input DI29	
[37]	Digital input DI32	
[38]	Digital input DI33	
[39]	Start command	
[40]	Drive stopped	
[41]	Reset Trip	
[42]	Auto Reset Trip	
[43]	OK key	
[44]	Reset Key	
[45]	Left Key	
[46]	Right Key	
[47]	Up Key	
[48]	Down Key	
[50]	Comparator 4	
[51]	Comparator 5	
[60]	Logic rule 4	
[61]	Logic rule 5	
[70]	SL Timeout 3	
[71]	SL Timeout 4	
[72]	SL Timeout 5	
[73]	SL Timeout 6	
[74]	SL Timeout 7	
[76]	Digital Input x30 2	
[77]	Digital Input x30 3	
[78]	Digital Input x30 4	
[80]	No Flow	
[81]	Dry Pump	
[82]	End of Curve	

13-42 Logic Rule Boolean 2		
Array [6]		
Option:	Function:	
[83]	Broken Belt	
[90]	ECB Drive Mode	
[91]	ECB Bypass Mode	
[92]	ECB Test Mode	
[100]	Fire Mode	

13-43 Logic Rule Operator 2		
Array [6]		
Option:	Function:	
	Select the second logical operator to be used on the Boolean input calculated in 13-40 Logic Rule Boolean 1, 13-41 Logic Rule Operator 1, and 13-42 Logic Rule Boolean 2, and the Boolean input coming from 13-42 Logic Rule Boolean 2. [13-44] signifies the Boolean input of 13-44 Logic Rule Boolean 3. [13-40/13-42] signifies the Boolean input calculated in 13-40 Logic Rule Boolean 1, 13-41 Logic Operator 1, and 13-42 Logic Rule Boolean 2. [0] DISABLED (factory setting). select this option to ignore 13-44 Logic Rule Boolean 3.	
[0]	DISABLED	
[1]	AND	
[2]	OR	
[3]	AND NOT	
[4]	OR NOT	
[5]	NOT AND	
[6]	NOT OR	
[7]	NOT AND NOT	
[8]	NOT OR NOT	

13-44 Logic Rule Boolean 3		
Array [6]		
Option:	Function:	
	Select the third Boolean (TRUE or FALSE) input for the selected logic rule. See 13-40 Logic Rule Boolean 1 for further descriptions of choices and their functions.	
[0]	FALSE	
[1]	TRUE	
[2]	Running	
[3]	In range	
[4]	On reference	
[5]	Torque limit	

13-44 Logic Rule Boolean 3		
Array [6]		
Option:	Function:	
[6]	Current Limit	
[7]	Out of current range	
[8]	Below I low	
[9]	Above I high	
[10]	Out of speed range	
[11]	Below speed low	
[12]	Above speed high	
[13]	Out of feedb. range	
[14]	Below feedb. low	
[15]	Above feedb. high	
[16]	Thermal warning	
[17]	Mains out of range	
[18]	Reverse	
[19]	Warning	
[20]	Alarm (trip)	
[21]	Alarm (trip lock)	
[22]	Comparator 0	
[23]	Comparator 1	
[24]	Comparator 2	
[25]	Comparator 3	
[26]	Logic rule 0	
[27]	Logic rule 1	
[28]	Logic rule 2	
[29]	Logic rule 3	
[30]	SL Timeout 0	
[31]	SL Timeout 1	
[32]	SL Timeout 2	
[33]	Digital input DI18	
[34]	Digital input DI19	
[35]	Digital input DI27	
[36]	Digital input DI29	
[37]	Digital input DI32	
[38]	Digital input DI33	
[39]	Start command	
[40]	Drive stopped	
[41]	Reset Trip	
[42]	Auto Reset Trip	
[43]	OK key	
[44]	Reset Key	
[45]	Left Key	
[46]	Right Key	
[47]	Up Key	
[48]	Down Key	
[50]	Comparator 4	
[51]	Comparator 5	
[60]	Logic rule 4	
[61]	Logic rule 5	
[70]	SL Timeout 3	

13-44 Logic Rule Boolean 3		
Array [6]		
Option:	Function:	
[71]	SL Timeout 4	
[72]	SL Timeout 5	
[73]	SL Timeout 6	
[74]	SL Timeout 7	
[76]	Digital Input x30 2	
[77]	Digital Input x30 3	
[78]	Digital Input x30 4	
[80]	No Flow	
[81]	Dry Pump	
[82]	End of Curve	
[83]	Broken Belt	
[90]	ECB Drive Mode	
[91]	ECB Bypass Mode	
[92]	ECB Test Mode	
[100]	Fire Mode	

3.12.6 13-5* States

13-51 SL Controller Event		
Array [20]		
Option:	Function:	
		Select the Boolean input (TRUE or FALSE) to define the Smart Logic Controller event. See 13-02 Stop Event for further descriptions of choices and their functions.
[0]	FALSE	
[1]	TRUE	
[2]	Running	
[3]	In range	
[4]	On reference	
[5]	Torque limit	
[6]	Current Limit	
[7]	Out of current range	
[8]	Below I low	
[9]	Above I high	
[10]	Out of speed range	
[11]	Below speed low	
[12]	Above speed high	
[13]	Out of feedb. range	
[14]	Below feedb. low	
[15]	Above feedb. high	
[16]	Thermal warning	
[17]	Mains out of range	
[18]	Reverse	
[19]	Warning	

13-51 SL Controller Event		
Array [20]		
Option:	Function:	
[20]	Alarm (trip)	
[21]	Alarm (trip lock)	
[22]	Comparator 0	
[23]	Comparator 1	
[24]	Comparator 2	
[25]	Comparator 3	
[26]	Logic rule 0	
[27]	Logic rule 1	
[28]	Logic rule 2	
[29]	Logic rule 3	
[30]	SL Timeout 0	
[31]	SL Timeout 1	
[32]	SL Timeout 2	
[33]	Digital input DI18	
[34]	Digital input DI19	
[35]	Digital input DI27	
[36]	Digital input DI29	
[37]	Digital input DI32	
[38]	Digital input DI33	
[39]	Start command	
[40]	Drive stopped	
[41]	Reset Trip	
[42]	Auto Reset Trip	
[43]	OK key	
[44]	Reset Key	
[45]	Left Key	
[46]	Right Key	
[47]	Up Key	
[48]	Down Key	
[50]	Comparator 4	
[51]	Comparator 5	
[60]	Logic rule 4	
[61]	Logic rule 5	
[70]	SL Timeout 3	
[71]	SL Timeout 4	
[72]	SL Timeout 5	
[73]	SL Timeout 6	
[74]	SL Timeout 7	
[76]	Digital Input x30 2	
[77]	Digital Input x30 3	
[78]	Digital Input x30 4	
[80]	No Flow	
[81]	Dry Pump	
[82]	End of Curve	
[83]	Broken Belt	
[90]	ECB Drive Mode	
[91]	ECB Bypass Mode	
[92]	ECB Test Mode	

13-51 SL Controller Event		
Array [20]		
Option:	Function:	
[100]	Fire Mode	

13-52 SL Controller Action		
Array [20]		
Option:	Function:	
		Select the action corresponding to the SLC event. Actions are executed when the corresponding event (defined in <i>13-51 SL Controller Event</i>) is evaluated as true. The following actions are available for selection:
[0]	Disabled	
[1]	No action	
[2]	Select set-up 1	Changes the active set-up (<i>0-10 Active Set-up</i>) to '1'.
[3]	Select set-up 2	Changes the active set-up (<i>0-10 Active Set-up</i>) to '2'.
[4]	Select set-up 3	Changes the active set-up (<i>0-10 Active Set-up</i>) to '3'.
[5]	Select set-up 4	Changes the active set-up (<i>0-10 Active Set-up</i>) to '4'. If the set-up is changed, it will merge with other set-up commands coming from either the digital inputs or via a serial communication bus.
[10]	Select preset ref 0	Selects preset reference 0.
[11]	Select preset ref 1	Selects preset reference 1.
[12]	Select preset ref 2	Selects preset reference 2.
[13]	Select preset ref 3	Selects preset reference 3.
[14]	Select preset ref 4	Selects preset reference 4.
[15]	Select preset ref 5	Selects preset reference 5.
[16]	Select preset ref 6	Selects preset reference 6.
[17]	Select preset ref 7	Selects preset reference 7. If the active preset reference is changed, it will merge with other preset reference commands coming from either the digital inputs or via a serial communication bus.
[18]	Select ramp 1	Selects ramp 1
[19]	Select ramp 2	Selects ramp 2

13-52 SL Controller Action		
Array [20]		
Option:	Function:	
[22]	Run	Issues a start command to the adjustable frequency drive.
[23]	Run reverse	Issues a start reverse command to the adjustable frequency drive.
[24]	Stop	Issues a stop command to the adjustable frequency drive.
[26]	DC Brake	Issues a DC stop command to the adjustable frequency drive.
[27]	Coast	The adjustable frequency drive coasts immediately. All stop commands including the coast command stop the SLC.
[28]	Freeze output	Freezes the output frequency of the adjustable frequency drive.
[29]	Start timer 0	Starts timer 0, see <i>13-20 SL Controller Timer</i> for further description.
[30]	Start timer 1	Starts timer 1, see <i>13-20 SL Controller Timer</i> for further description.
[31]	Start timer 2	Starts timer 2, see <i>13-20 SL Controller Timer</i> for further description.
[32]	Set digital out A low	Any output with 'digital output 1' selected is low (off).
[33]	Set digital out B low	Any output with 'digital output 2' selected is low (off).
[34]	Set digital out C low	Any output with 'digital output 3' selected is low (off).
[35]	Set digital out D low	Any output with 'digital output 4' selected is low (off).
[36]	Set digital out E low	Any output with 'digital output 5' selected is low (off).
[37]	Set digital out F low	Any output with 'digital output 6' selected is low (off).
[38]	Set digital out A high	Any output with 'digital output 1' selected is high (closed).
[39]	Set digital out B high	Any output with 'digital output 2' selected is high (closed).
[40]	Set digital out C high	Any output with 'digital output 3' selected is high (closed).
[41]	Set digital out D high	Any output with 'digital output 4' selected is high (closed).
[42]	Set digital out E high	Any output with 'digital output 5' selected is high (closed).

13-52 SL Controller Action		
Array [20]		
Option:	Function:	
[43]	Set digital out F high	Any output with 'digital output 6' selected is high (closed).
[60]	Reset Counter A	Resets Counter A to zero.
[61]	Reset Counter B	Resets Counter A to zero.
[70]	Start Timer 3	Starts timer 3, see <i>13-20 SL Controller Timer</i> for further description.
[71]	Start Timer 4	Starts timer 4, see <i>13-20 SL Controller Timer</i> for further description.
[72]	Start Timer 5	Starts timer 5, see <i>13-20 SL Controller Timer</i> for further description.
[73]	Start Timer 6	Starts timer 6, see <i>13-20 SL Controller Timer</i> for further description.
[74]	Start Timer 7	Starts timer 7, see <i>13-20 SL Controller Timer</i> for further description.
[80]	Sleep Mode	Starts Sleep mode.
[90]	Set ECB Bypass Mode	
[91]	Set ECB Drive Mode	
[100]	Reset Alarms	

3.13 Parameters 14-** Special Functions

3.13.1 14-0* Inverter Switching

14-00 Switching Pattern		
Option:	Function:	
		Select the switching pattern: 60° AVM or SFAVM.
[0]	60 AVM	
[1]	SFAVM	

14-01 Switching Frequency		
Option:	Function:	
		Select the inverter switching frequency. Changing the switching frequency can help to reduce acoustic noise from the motor.
		NOTICE! The output frequency value of the adjustable frequency drive must never exceed 1/10 of the switching frequency. When the motor is running, adjust the switching frequency in <i>14-01 Switching Frequency</i> until the motor is as noiseless as possible. See also <i>14-00 Switching Pattern</i> and the section <i>Derating</i> .
[0]	1.0 kHz	
[1]	1.5 kHz	
[2]	2.0 kHz	
[3]	2.5 kHz	
[4]	3.0 kHz	
[5]	3.5 kHz	
[6]	4.0 kHz	
[7]	5.0 kHz	
[8]	6.0 kHz	
[9]	7.0 kHz	
[10]	8.0 kHz	
[11]	10.0 kHz	
[12]	12.0 kHz	
[13]	14.0 kHz	
[14]	16.0 kHz	

14-03 Overmodulation		
Option:	Function:	
[0]	Off	Selects no overmodulation of the output voltage in order to avoid torque ripple on the motor shaft.
[1]	On	The overmodulation function generates an extra voltage of up-to 8% of U_{max} output voltage without overmodulation, which results in an extra torque of 10-12% in the middle of the over-synchronous range (from 0% at nominal speed rising to approximately 12% at double nominal speed).

NOTICE!

Enabling overmodulation can cause vibrations that may destroy the mechanics if running in field weakening areas (from 47 Hz).

14-04 PWM Random		
Option:	Function:	
[0]	Off	No change of the acoustic motor switching noise.
[1]	On	Transforms the acoustic motor switching noise from a clear ringing tone to a less noticeable 'white' noise. This is achieved by slightly and randomly altering the synchronism of the pulse width modulated output phases.

3.13.2 14-1* >Mains Power On/Off

Parameters for configuring line failure monitoring and handling.

14-10 Mains Failure		
Option:	Function:	
		Select the function at which the adjustable frequency drive must act when the threshold set in <i>14-11 Mains Voltage at Mains Fault</i> has been reached or a <i>Mains Failure Inverse</i> command is activated via one of the digital inputs (parameter group 5-1*). Only selection [0] No function, [3] Coasting or [6] Alarm is available when <i>1-10 Motor Construction</i> is set to [1] PM, non-salient SPM.
[0]	No function	The energy left in the capacitor bank will be used to run the motor, but will be discharged.
[1]	Ctrl. ramp-down	The adjustable frequency drive will perform a controlled ramp-down. <i>2-10 Brake Function</i> must be set to [0] Off.
[3]	Coasting	The inverter will turn off and the capacitor bank will back up the control card, thus ensuring a faster restart when line power is reconnected (for short power zags).
[4]	Kinetic back-up	The adjustable frequency drive will ride through by controlling speed for generative operation of the motor utilizing the moment of inertia of the system as long as sufficient energy is present.
[6]	Ctrl. alarm suppress	

3

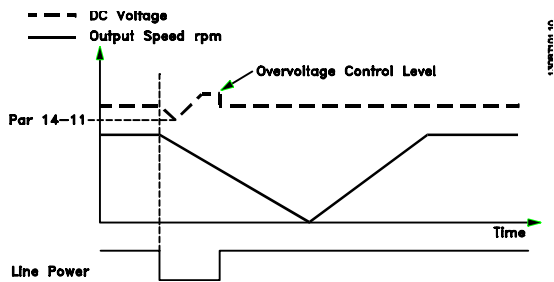

Figure 3.37 Controlled Ramp-down - Short Line Failure. Ramping down to stop followed by ramping up to reference.

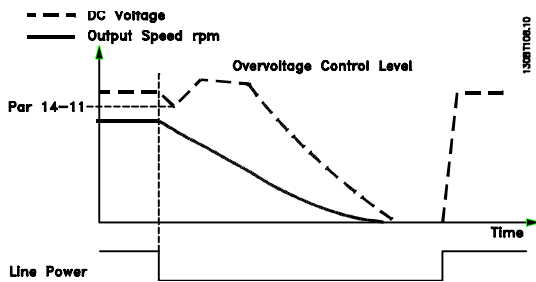

Figure 3.38 Controlled Ramp-down, Longer Line Failure. Ramping down as long as the energy in the system allows for it, then the motor is coasted.

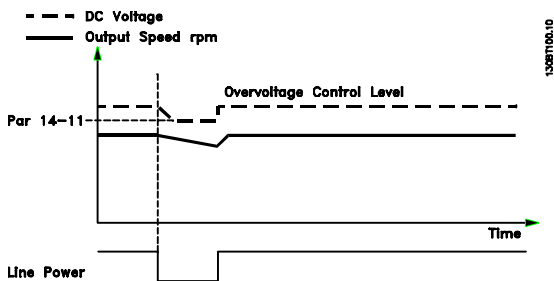

Figure 3.39 Kinetic Backup, Short Line Failure. Ride through as long as the energy in the system allows for it.

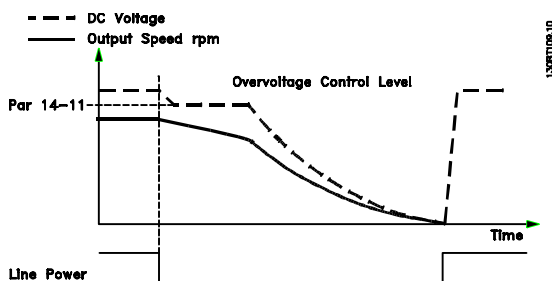

Figure 3.40 Kinetic Backup, Longer Line Failure. The motor is coasted as soon as the energy in the system is too low.

14-11 Mains Voltage at Mains Fault		
Range:	Function:	
Size related* [180 - 600 V]	This parameter defines the threshold voltage at which the selected function in 14-10 Mains Failure should be activated. The detection level is at a factor ² of the value in 14-11 Mains Voltage at Mains Fault.	

14-12 Function at Mains Imbalance		
Option:	Function:	
	Operating under severe line imbalance conditions reduces the lifetime of the motor. Conditions are considered severe if the motor operates continuously near nominal load (such as when a pump or fan runs near full speed). When a severe line imbalance is detected:	
[0]	Trip	Select [0] Trip to trip the adjustable frequency drive.
[1]	Warning	Select [1] Warning to issue a warning.
[2]	Disabled	Select [2] Disabled for no action.
[3]	Derate	Select [3] Derate for derating the adjustable frequency drive.

Parameters for configuring auto reset handling, special trip handling and control card self test or initialization.

14-20 Reset Mode		
Option:	Function:	
[0]	Manual reset	
[1]	Automatic reset x 1	
[2]	Automatic reset x 2	
[3]	Automatic reset x 3	
[4]	Automatic reset x 4	
[5]	Automatic reset x 5	
[6]	Automatic reset x 6	
[7]	Automatic reset x 7	
[8]	Automatic reset x 8	
[9]	Automatic reset x 9	
[10]	Automatic reset x 10	
[11]	Automatic reset x 15	
[12]	Automatic reset x 20	
[13]	Infinite auto reset	Select the reset function after tripping. Once reset, the adjustable frequency drive can be restarted. Select [0] Manual reset to perform a reset via [Reset] or via the digital inputs. Select [1]-[12] Automatic reset x 1...x20 to perform between one and twenty automatic resets after tripping.

14-20 Reset Mode	
Option:	Function:
	Select [13] <i>Infinite Automatic Reset</i> for continuous resetting after tripping. NOTICE! The motor may start without warning. If the specified number of AUTOMATIC RESETs is reached within 10 minutes, the adjustable frequency drive enters [0] <i>Manual reset mode</i> . After the manual reset is performed, the setting of 14-20 <i>Reset Mode</i> reverts to the original selection. If the number of automatic resets is not reached within 10 minutes, or when a Manual reset is performed, the internal AUTOMATIC RESET counter returns to zero.

14-21 Automatic Restart Time	
Range:	Function:
10 s* [0 - 600 s]	Enter the time interval from trip to start of the automatic reset function. This parameter is active when 14-20 <i>Reset Mode</i> is set to [1] - [13] <i>Automatic reset</i> .

14-22 Operation Mode	
Option:	Function:
	Use this parameter to specify normal operation, to perform tests or to initialize all parameters except 15-03 <i>Power-ups</i> , 15-04 <i>Over Temps</i> and 15-05 <i>Over Volts</i> . This function is active only when the power is cycled (power off-power on) to the adjustable frequency drive.
[0] Normal operation	Select [0] <i>Normal operation</i> for normal operation of the adjustable frequency drive with the motor in the selected application.
[1] Control card test	Select [1] <i>Control card test</i> to test the analog and digital inputs and outputs and the +10 V control voltage. The test requires a test connector with internal connections. Use the following procedure for the control card test: <ol style="list-style-type: none"> Select [1] <i>Control card test</i>. Disconnect the line power supply and wait for the light in the display to go out.

14-22 Operation Mode	
Option:	Function:
	<ol style="list-style-type: none"> Set switches S201 (A53) and S202 (A54) = 'ON/I'. Insert the test plug (see Figure 3.41). Connect to the line power supply. Carry out various tests. The results are displayed on the LCP, and the adjustable frequency drive moves into an infinite loop. 14-22 <i>Operation Mode</i> is automatically set to Normal operation. Carry out a power cycle to start up in normal operation after a control card test.
	If the test is OK: LCP readout: Control Card OK. Disconnect the line power supply and remove the test plug. The green LED on the control card will light up.
	If the test fails: LCP readout: Control Card I/O failure. Replace the adjustable frequency drive or control card. The red LED on the control card is turned on. To test the plugs, connect/group the following terminals as shown in Figure 3.41: (18 - 27 - 32), (19 - 29 - 33) and (42 - 53 - 54).
[2] Initialization	Select [2] <i>Initialization</i> to reset all parameter values to default settings, except for 15-03 <i>Power-ups</i> , 15-04 <i>Over Temps</i> and 15-05 <i>Over Volts</i> . The adjustable frequency drive will reset during the next power-up. 14-22 <i>Operation Mode</i> will also revert to the default setting [0] <i>Normal operation</i> .
[3] Boot mode	

Figure 3.41 Wiring Control Card Test

14-23 Typecode Setting		
Option: Function:		
		Use this parameter to set the type code matching the specific adjustable frequency drive. Use this parameter to set the type code matching the specific adjustable frequency drive.

14-25 Trip Delay at Torque Limit		
Range:		Function:
60 s*	[0 - 60 s]	Enter the torque limit trip delay in seconds. When the output torque reaches the torque limits (4-16 <i>Torque Limit Motor Mode</i> and 4-17 <i>Torque Limit Generator Mode</i>), a warning is triggered. When the torque limit warning has been continuously present for the period specified in this parameter, the adjustable frequency drive trips. Disable the trip delay by setting the parameter to 60 s = OFF. Thermal adjustable frequency drive monitoring will still remain active.

14-26 Trip Delay at Inverter Fault		
Range:		Function:
Size related*	[0 - 35 s]	When the adjustable frequency drive detects an overvoltage in the set time, tripping will be affected after the set time.

3.13.3 14-3* Current Limit Control

The adjustable frequency drive features an integral current limit controller which is activated when the motor current, and thus the torque, is higher than the torque limits set in 4-16 *Torque Limit Motor Mode* and 4-17 *Torque Limit Generator Mode*.

When the current limit is reached during motor operation or regenerative operation, the adjustable frequency drive will try to reduce torque below the preset torque limits as quickly as possible without losing control of the motor. While the current control is active, the adjustable frequency drive can only be stopped by setting a digital input to [2] *Coast inverse* or [3] *Coast and reset inv.* Any signal on terminals 18 to 33 will not be active until the adjustable frequency drive is no longer near the current limit.

By using a digital input set to [2] *Coast inverse* or [3] *Coast and reset inv.*, the motor does not use the ramp-down time, since the adjustable frequency drive is coasted.

14-30 Current Lim Ctrl, Proportional Gain		
Range:		Function:
100 %*	[0 - 500 %]	Enter the proportional gain value for the current limit controller. Selection of a high value makes the controller react faster. Too high a setting leads to controller instability.

14-31 Current Lim Ctrl, Integration Time		
Range:		Function:
Size related*	[0.002 - 2 s]	

14-32 Current Lim Ctrl, Filter Time		
Range:		Function:
Size related*	[1 - 100 ms]	

3.13.4 14-4* Energy Optimizing

Parameters for adjusting the energy optimization level in both variable torque (VT) and automatic energy optimization (AEO) mode.

Automatic Energy Optimization is only active if 1-03 *Torque Characteristics*, is set for either [2] *Auto Energy Optim. CT* or [3] *Auto Energy Optim. VT*.

14-40 VT Level		
Range:		Function:
66 %*	[40 - 90 %]	

NOTICE!

This parameter is not active when 1-10 *Motor Construction* is set to [1] PM, non-salient SPM.

NOTICE!

This parameter cannot be adjusted while the motor is running.

14-41 AEO Minimum Magnetization		
Range:		Function:
Size related*	[40 - 75 %]	Enter the minimum allowable magnetization for AEO. Selection of a low value reduces energy loss in the motor, but can also reduce resistance to sudden load changes.

NOTICE!

This parameter is not active when 1-10 *Motor Construction* is set to [1] PM, non-salient SPM.

14-42 Minimum AEO Frequency		
Range:		Function:
10 Hz*	[5 - 40 Hz]	Enter the minimum frequency at which the Automatic Energy Optimization (AEO) is to be active.

NOTICE!

This parameter is not active when 1-10 Motor Construction is set to [1] PM, non-salient SPM.

14-43 Motor Cos-Phi		
Range:		Function:
Size related*	[0.40 - 0.95]	The cos-phi setpoint is automatically set for optimum AEO performance during AMA. This parameter should normally not be altered. However, in some situations it may be necessary to enter a new value to fine tune.

NOTICE!

This parameter is not active when 1-10 Motor Construction is set to [1] PM, non-salient SPM.

3.13.5 14-5* Environment

These parameters help the adjustable frequency drive to operate under special environmental conditions.

14-50 RFI 1		
Option:		Function:
[0]	Off	
[1]	On	Select [1] On to ensure the adjustable frequency drive complies with EMC standards. Select [0] Off only when the adjustable frequency drive is supplied from an isolated line power source, i.e., IT line power. In this mode, the internal RFI capacities (filter capacitors) between chassis and the Line Power RFI Filter Circuit are cut off to avoid damage to the intermediate circuit and to reduce the ground capacity currents (according to IEC 61800-3).

14-51 DC Link Compensation		
Option:		Function:
		The rectified AC/DC voltage at the adjustable frequency drive's DC link is associated with voltage ripples. These ripples can increase in magnitude with increased load. These ripples are undesirable because they can generate current and torque ripples. A compensation method is used to reduce these voltage ripples at DC link. In general, DC link compensation is recommended for most applications, but care must be taken when operating in field weakening as it can generate speed

14-51 DC Link Compensation		
Option:		Function:
		oscillations at the motor shaft. In field weakening, it is recommended to turn DC link compensation off.
[0]	Off	Disables DC Link Compensation.
[1]	On	Enables DC Link Compensation.

14-52 Fan Control		
Option:		Function:
		Select the minimum speed of the main fan.
[0]	Auto	Select [0] Auto to run the fan only when the internal temperature of the adjustable frequency drive is in the range 95° F [+35°C] to approximately 131° F [+55°C]. The fan will run at low speed at 95° F [+35°C] and at full speed at approximately 131° F [+55°C].
[1]	On 50%	
[2]	On 75%	
[3]	On 100%	
[4]	Auto (Low temp env.)	

14-53 Fan Monitor		
Option:		Function:
		Select which action the adjustable frequency drive should take in case a fan fault is detected.
[0]	Disabled	
[1]	Warning	
[2]	Trip	

14-55 Output Filter		
Option:		Function:
		Select the type of output filter connected.
[0]	No Filter	
[1]	Sine-Wave Filter	
[2]	Sine-Wave Filter Fixed	If a Danfoss sine-wave filter is connected to the output, this option secures that the switching frequency is fixed above the design frequency of the filter (to be set in 14-01 Switching Frequency) in the specific power size. This prevents the filter from being noisy, overheated and damaged.

NOTICE!
The switching frequency will still be automatically controlled by the TAS feature depending on the temperature but limited to always be above the critical level for the Danfoss filter.

NOTICE!

This parameter cannot be adjusted while motor is running.

3

14-59 Actual Number of Inverter Units		
Range:	Function:	
Size related*	[1 - 1]	Sets the actual number of operating inverter units.

3.13.6 14-6* Auto Derate

This group contains parameters for derating the adjustable frequency drive in case of high temperature.

14-60 Function at Overtemperature		
If either heatsink or control card temperature exceeds a programmed temperature limit, a warning will be activated. If the temperature increases further, select whether the adjustable frequency drive should trip (trip locked) or derate the output current.		
Option:	Function:	
[0]	Trip	The adjustable frequency drive will trip (trip locked) and generate an alarm. Power must be cycled to reset the alarm, but will not allow restart of the motor until the heatsink temperature has dropped below the alarm limit.
[1]	Derate	If the critical temperature is exceeded, the output current will be reduced until the allowable temperature has been reached.

3.13.7 No Trip at Inverter Overload

In some pump systems, the adjustable frequency drive has not been sized properly to yield the current needed in all points of the operational flow-head characteristic. At these points, the pump will need a current higher than the rated current of the adjustable frequency drive. The adjustable frequency drive can yield 110% of the rated current continuously for 60 s. If still overloaded, the adjustable frequency drive will normally trip (causing the pump to stop by coasting) and provide an alarm.

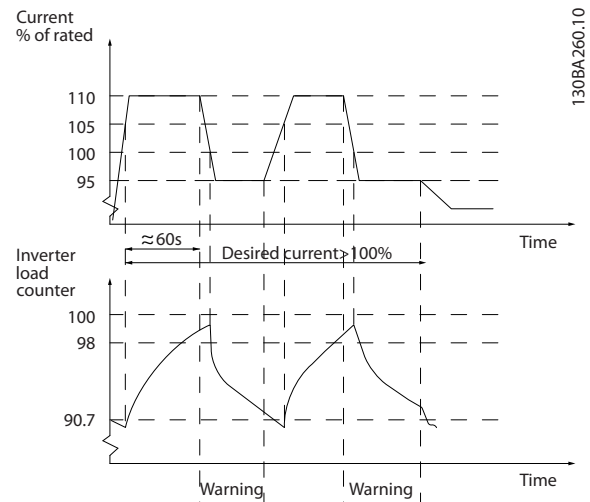

Figure 3.42

It may be preferable to run the pump at reduced speed for a while in cases where it is not possible to run continuously with demanded capacity.

Select 14-61 *Function at Inverter Overload* to automatically reduce pump speed until the output current is below 100% of the rated current (set in 14-62 *Inv. Overload Derate Current*).

14-61 *Function at Inverter Overload* is an alternative to letting the adjustable frequency drive trip.

The adjustable frequency drive estimates the load on the power section by means of an inverter load counter, which will cause a warning at 98% and a reset of the warning at 90%. At the value 100%, the adjustable frequency drive trips and provides an alarm.

Status for the counter can be read in 16-35 *Inverter Thermal*.

If 14-61 *Function at Inverter Overload* is set to [3] *Derate*, the pump speed will be reduced when the counter exceeds 98, and stay reduced until the counter has dropped below 90.7.

If 14-62 *Inv. Overload Derate Current* is set, for example, to 95% a steady overload will cause the pump speed to fluctuate between values corresponding to 110% and 95% of rated output current for the adjustable frequency drive.

14-61 Function at Inverter Overload		
Is used in case of steady overload beyond the thermal limits (110% for 60 s).		
Option:	Function:	
[0]	Trip	Choose [0] Trip to make the adjustable frequency drive trip and provide an alarm.
[1]	Derate	[1] Derate reduces pump speed in order to decrease the load on the power section and allowing this to cool down.

14-62 Inv. Overload Derate Current		
Range:	Function:	
95 %*	[50 - 100 %]	

Failure	Parameter	Alarm	Off	Warning	Trip	Trip Lock
10 V low	1490.0	1	X	D		
24 V low	1490.1	47	X			D
1.8ÆV supply low	1490.2	48	X			D
Voltage limit	1490.3	64	X	D		
Ground Fault	1490.4 ¹⁾	14			D	X
Earth Fault 2	1490.5 ¹⁾	45			D	X
Derag Limit Fault	1490.16 ^{1, 2)}	100			D	X

Table 3.18 Table for selection of choice of action when selected alarm appears

D = Default setting. x = possible selection.

1) Only these faults are configurable on the FC 202. Due to a software limitation with array parameters, all of the other will show in the MCT 10 Set-up Software. For the other parameter indices, writing any other value than its current value (i.e., the default value) will return a "value out of range" error. Thus, you are not allowed to change the fault level for the non-configurable ones.

2) This parameter has been 1490.6 in all firmware versions up to 1.86.

3.13.8 14-9* Fault Settings

14-90 Fault Level		
Option:	Function:	
[0]	Off	Use this parameter to customize fault levels. Use [0] Off with caution as it will ignore all warnings and alarms for the chosen source.
[1]	Warning	
[2]	Trip	
[3]	Trip Lock	

3.14 Parameters 15-** Adjustable Frequency Drive Information

Parameter group containing adjustable frequency drive information such as operating data, hardware configuration and software versions.

3.14.1 15-0* Operating Data

15-00 Operating hours		
Range:	Function:	
0 h* [0 - 2147483647 h]	View how many hours the adjustable frequency drive has run. The value is saved when the adjustable frequency drive is turned off.	

15-01 Running Hours		
Range:	Function:	
0 h* [0 - 2147483647 h]	View how many hours the motor has run. Reset the counter in <i>15-07 Reset Running Hours Counter</i> . The value is saved when the adjustable frequency drive is turned off.	

15-02 kWh Counter		
Range:	Function:	
0 kWh* [0 - 2147483647 kWh]	Registering the power consumption of the motor as a mean value over one hour. Reset the counter in <i>15-06 Reset kWh Counter</i> .	

15-03 Power-ups		
Range:	Function:	
0 * [0 - 2147483647]	View the number of times the adjustable frequency drive has been powered up.	

15-04 Over Temps		
Range:	Function:	
0 * [0 - 65535]	View the number of adjustable frequency drive temperature faults which have occurred.	

15-05 Over Volts		
Range:	Function:	
0 * [0 - 65535]	View the number of adjustable frequency drive overvoltages which have occurred.	

15-06 Reset kWh Counter		
Option:	Function:	
[0] Do not reset	Select [0] <i>Do not reset</i> if no reset of the kWh counter is desired.	

15-06 Reset kWh Counter		
Option:	Function:	
[1] Reset counter	Select [1] <i>Reset</i> and press [OK] to reset the kWh counter to zero (see <i>15-02 kWh Counter</i>).	

NOTICE!

The reset is carried out by pressing [OK].

15-07 Reset Running Hours Counter		
Option:	Function:	
[0] Do not reset	Select [0] <i>Do not reset</i> if no reset of the Running Hours counter is desired.	
[1] Reset counter	Select [1] <i>Reset counter</i> and press [OK] to reset the Running Hours counter (<i>15-01 Running Hours</i>) and <i>15-08 Number of Starts</i> to zero (see also <i>15-01 Running Hours</i>).	

15-08 Number of Starts		
Range:	Function:	
0 * [0 - 2147483647]	This is a readout parameter only. The counter shows the numbers of starts and stops caused by a normal Start/Stop command and/or when entering/leaving sleep mode.	

NOTICE!

This parameter will be reset when resetting *15-07 Reset Running Hours Counter*.

3.14.2 15-1* Data Log Settings

The Data Log enables continuous logging of up to 4 data sources (*15-10 Logging Source*) at individual rates (*15-11 Logging Interval*). A trigger event (*15-12 Trigger Event*) and window (*15-14 Samples Before Trigger*) are used to start and stop the logging conditionally.

15-10 Logging Source		
Option:	Function:	
[0] None	Select which variables are to be logged.	
[1600] Control Word		
[1601] Reference [Unit]		
[1602] Reference [%]		
[1603] Status Word		
[1610] Power [kW]		
[1611] Power [hp]		
[1612] Motor voltage		
[1613] Frequency		

15-10 Logging Source		
Array [4]		
Option:	Function:	
[1614]	Motor current	
[1616]	Torque [Nm]	
[1617]	Speed [RPM]	
[1618]	Motor Thermal	
[1622]	Torque [%]	
[1630]	DC Link Voltage	
[1632]	Brake Energy /s	
[1633]	Brake Energy /2 min	
[1634]	Heatsink Temp.	
[1635]	Inverter Thermal	
[1650]	External Reference	
[1652]	Feedback [Unit]	
[1654]	Feedback 1 [Unit]	
[1655]	Feedback 2 [Unit]	
[1656]	Feedback 3 [Unit]	
[1659]	Adjusted Setpoint	
[1660]	Digital Input	
[1662]	Analog Input 53	
[1664]	Analog Input 54	
[1665]	Analog Output 42 [mA]	
[1666]	Digital Output [bin]	
[1675]	Analog In X30/11	
[1676]	Analog In X30/12	
[1677]	Analog Out X30/8 [mA]	
[1690]	Alarm Word	
[1691]	Alarm Word 2	
[1692]	Warning Word	
[1693]	Warning Word 2	
[1694]	Ext. Status Word	
[1695]	Ext. Status Word 2	
[1830]	Analog Input X42/1	
[1831]	Analog Input X42/3	
[1832]	Analog Input X42/5	
[1833]	Analog Out X42/7 [V]	
[1834]	Analog Out X42/9 [V]	
[1835]	Analog Out X42/11 [V]	
[1860]	Digital Input 2	
[2791]	Cascade Reference	
[3110]	Bypass Status Word	

15-11 Logging Interval		
Array [4]		
Range:	Function:	
Size related*	[0.000 - 0.000]	Enter the interval in milliseconds between each sampling of the variables to be logged.

15-12 Trigger Event		
Option:	Function:	
		Selects the trigger event. When the trigger event occurs, a window is applied to freeze the log. The log will then retain a specified percentage of samples before the occurrence of the trigger event (<i>15-14 Samples Before Trigger</i>).
[0]	FALSE	
[1]	TRUE	
[2]	Running	
[3]	In range	
[4]	On reference	
[5]	Torque limit	
[6]	Current Limit	
[7]	Out of current range	
[8]	Below I low	
[9]	Above I high	
[10]	Out of speed range	
[11]	Below speed low	
[12]	Above speed high	
[13]	Out of feedb. range	
[14]	Below feedb. low	
[15]	Above feedb. high	
[16]	Thermal warning	
[17]	Mains out of range	
[18]	Reverse	
[19]	Warning	
[20]	Alarm (trip)	
[21]	Alarm (trip lock)	
[22]	Comparator 0	
[23]	Comparator 1	
[24]	Comparator 2	
[25]	Comparator 3	
[26]	Logic rule 0	
[27]	Logic rule 1	
[28]	Logic rule 2	
[29]	Logic rule 3	
[33]	Digital input DI18	
[34]	Digital input DI19	
[35]	Digital input DI27	
[36]	Digital input DI29	
[37]	Digital input DI32	
[38]	Digital input DI33	
[50]	Comparator 4	
[51]	Comparator 5	
[60]	Logic rule 4	
[61]	Logic rule 5	

15-13 Logging Mode		
Option:	Function:	
[0]	Log always	Select [0] <i>Log always</i> for continuous logging.
[1]	Log once on trigger	Select [1] <i>Log once on trigger</i> to conditionally start and stop logging using 15-12 <i>Trigger Event</i> and 15-14 <i>Samples Before Trigger</i> .

15-14 Samples Before Trigger		
Range:	Function:	
50 *	[0 - 100]	Enter the percentage of all samples before a trigger event which are to be retained in the log. See also 15-12 <i>Trigger Event</i> and 15-13 <i>Logging Mode</i> .

3.14.3 15-2* Historic Log

View up to 50 logged data items via the array parameters in this parameter group. For all parameters in the group, [0] is the most recent data and [49] the oldest data. Data is logged every time an *event* occurs (not to be confused with SLC events). *Events* in this context are defined as a change in one of the following areas

1. Digital input
2. Digital outputs (not monitored in this SW release)
3. Warning word
4. Alarm word
5. Status word
6. Control word
7. Extended status word

Events are logged with value, and time stamp in ms. The time interval between two events depends on how often *events* occur (maximum once every scan time). Data logging is continuous but if an alarm occurs, the log is saved and the values can be viewed on the display. This feature is useful, for example when carrying out service following a trip. View the historic log contained in this parameter via the serial communication port or via the display.

15-20 Historic Log: Event		
Array [50]		
Range:	Function:	
0 *	[0 - 255]	View the event type of the logged events.

15-21 Historic Log: Value		
Array [50]		
Range:	Function:	
0 *	[0 - 2147483647]	View the value of the logged event. Interpret the event values according to this table:
	Digital input	Decimal value. See 16-60 <i>Digital Input</i> for description after converting to binary value.
	Digital output (not monitored in this SW release)	Decimal value. See 16-66 <i>Digital Output [bin]</i> for description after converting to binary value.
	Warning word	Decimal value. See 16-92 <i>Warning Word</i> for description.
	Alarm word	Decimal value. See 16-90 <i>Alarm Word</i> for description.
	Status word	Decimal value. See 16-03 <i>Status Word</i> for description after converting to binary value.
	Control word	Decimal value. See 16-00 <i>Control Word</i> for description.
	Extended status word	Decimal value. See 16-94 <i>Ext. Status Word</i> for description.
Table 3.20		

15-22 Historic Log: Time		
Array [50]		
Range:	Function:	
0 ms*	[0 - 2147483647 ms]	View the time at which the logged event occurred. Time is measured in ms since adjustable frequency drive start. The max. value corresponds to approx. 24 days which means that the count will restart at zero after this time period.

15-23 Historic Log: Date and Time		
Array [50]		
Range:	Function:	
Size related* [0 - 0]	Array parameter; Date & Time 0-49: This parameter shows at which time the logged event occurred.	

3.14.4 15-3* Alarm Log

Parameters in this group are array parameters, where up to 10 fault logs can be viewed. [0] is the most recent logged data, and [9] the oldest. Error codes, values and time stamp can be viewed for all logged data.

15-30 Alarm Log: Error Code		
Array [10]		
Range:	Function:	
0 * [0 - 255]	View the error code and look up its meaning in <i>5 Troubleshooting</i> .	

15-31 Alarm Log: Value		
Array [10]		
Range:	Function:	
0 * [-32767 - 32767]	View an extra description of the error. This parameter is mostly used in combination with alarm 38 'internal fault'.	

15-32 Alarm Log: Time		
Array [10]		
Range:	Function:	
0 s* [0 - 2147483647 s]	View the time when the logged event occurred. Time is measured in seconds from adjustable frequency drive start-up.	

15-33 Alarm Log: Date and Time		
Array [10]		
Range:	Function:	
Size related* [0 - 0]	Array parameter; Date & Time 0-9: This parameter shows at which time the logged event occurred.	

15-34 Alarm Log: Setpoint		
Array [10]		
Range:	Function:	
0 ProcessCtrlUnit* [-999999.999 - 999999.999 ProcessCtrlUnit]	Array parameter, status value 0-9. This parameter shows the status of the alarm: 0: Alarm inactive	

15-34 Alarm Log: Setpoint		
Array [10]		
Range:	Function:	
	1: Alarm active	

15-35 Alarm Log: Feedback		
Array [10]		
Range:	Function:	
0 ProcessCtrlUnit* [-999999.999 - 999999.999 ProcessCtrlUnit]		

15-36 Alarm Log: Current Demand		
Array [10]		
Range:	Function:	
0 %* [0 - 100 %]		

15-37 Alarm Log: Process Ctrl Unit		
Array [10]		
Option:	Function:	
[0]	-	
[1]	%	
[5]	PPM	
[10]	min	
[11]	RPM	
[12]	PULSE/s	
[20]	liter / sec.	
[21]	liter / min	
[22]	liter / hr.	
[23]	m ³ / sec.	
[24]	m ³ /min	
[25]	m ³ / hr.	
[30]	kg / sec.	
[31]	kg/min	
[32]	kg / hr.	
[33]	ton / min	
[34]	ton / hr.	
[40]	m / sec.	
[41]	m/min	
[45]	m	
[60]	°C	
[70]	mbar	
[71]	bar	
[72]	Pa	
[73]	kPa	
[74]	m WG	
[75]	mm Hg	
[80]	kW	
[120]	GPM	
[121]	gal / sec.	
[122]	gal/min	
[123]	gal / hr.	

15-37 Alarm Log: Process Ctrl Unit		
Array [10]		
Option:	Function:	
[124]	CFM	
[125]	ft ³ /s	
[126]	ft ³ /min	
[127]	ft ³ /h	
[130]	lbs / sec.	
[131]	lbs / min.	
[132]	lbs / hr.	
[140]	ft/s	
[141]	ft/min	
[145]	ft	
[160]	°F	
[170]	psi	
[171]	lb/in ²	
[172]	in. wtr. gage	
[173]	ft WG	
[174]	in Hg	
[180]	HP	

3.14.5 15-4* Drive Identification

Parameters containing read-only information about the hardware and software configuration of the adjustable frequency drive.

15-40 FC Type		
Range:	Function:	
0 *	[0 - 0]	

15-41 Power Section		
Range:	Function:	
0 *	[0 - 0]	

15-42 Voltage		
Range:	Function:	
0 *	[0 - 0]	

15-43 Software Version		
Range:	Function:	
0 *	[0 - 0]	View the combined SW version (or 'package version') consisting of power SW and control SW.

15-44 Ordered Typecode String		
Range:	Function:	
0 *	[0 - 0]	View the type code string used for re-ordering the adjustable frequency drive in its original configuration.

15-45 Actual Typecode String		
Range:	Function:	
0 *	[0 - 0]	View the actual type code string.

15-46 Adj Freq Dr Ordering No.		
Range:	Function:	
0 *	[0 - 0]	View the 8-digit ordering number used for re-ordering the adjustable frequency drive in its original configuration.

15-47 Power Card Ordering No.		
Range:	Function:	
0 *	[0 - 0]	View the power card ordering number.

15-48 LCP ID Num.		
Range:	Function:	
0 *	[0 - 0]	View the LCP ID number.

15-49 SW ID Control Card		
Range:	Function:	
0 *	[0 - 0]	View the control card software version number.

15-50 SW ID Power Card		
Range:	Function:	
0 *	[0 - 0]	View the power card software version number.

15-51 Adj Freq Dr Serial No.		
Range:	Function:	
0 *	[0 - 0]	View the adjustable frequency drive serial number.

15-53 Power Card Serial Number		
Range:	Function:	
0 *	[0 - 0]	View the power card serial number.

15-59 CSIV Filename		
Range:	Function:	
Size related*	[0 - 0]	

3.14.6 15-6* Option Ident.

This read-only parameter group contains information about the hardware and software configuration of the options installed in slots A, B, C0 and C1.

15-60 Option Mounted		
Array [8]		
Range:	Function:	
0 *	[0 - 0]	View the installed option type.

15-61 Option SW Version		
Array [8]		
Range:	Function:	
0 *	[0 - 0]	View the installed option software version.

15-62 Option Ordering No		
Array [8]		
Range:	Function:	
0 *	[0 - 0]	Shows the ordering number for the installed options.

15-63 Option Serial No		
Array [8]		
Range:	Function:	
0 *	[0 - 0]	View the installed option serial number.

15-70 Option in Slot A		
Range:	Function:	
0 *	[0 - 0]	View the type code string for the option installed in slot A, and a translation of the type code string. For example, for type code string 'AX', the translation is 'No option'.

15-71 Slot A Option SW Version		
Range:	Function:	
0 *	[0 - 0]	View the software version for the option installed in slot A.

15-72 Option in Slot B		
Range:	Function:	
0 *	[0 - 0]	View the type code string for the option installed in slot B, and a translation of the type code string. For example, for type code string 'BX', the translation is 'No option'.

15-73 Slot B Option SW Version		
Range:	Function:	
0 *	[0 - 0]	View the software version for the option installed in slot B.

15-74 Option in Slot C0		
Range:	Function:	
0 *	[0 - 0]	View the type code string for the option installed in slot C, and a translation of the type code string. For example, for type code string 'CXXX', the translation is 'No option'.

15-75 Slot C0/E0 Option SW Version		
Range:	Function:	
0 *	[0 - 0]	View the software version for the option installed in slot C.

15-76 Option in Slot C1		
Range:	Function:	
0 *	[0 - 0]	Shows the typecode string for the options (CXXX if no option) and the translation, e.g., >No option<.

15-77 Slot C1/E1 Option SW Version		
Range:	Function:	
0 *	[0 - 0]	Software version for the installed option in option slot C.

15-92 Defined Parameters		
Array [1,000]		
Range:	Function:	
0 *	[0 - 9999]	View a list of all defined parameters in the adjustable frequency drive. The list ends with 0.

15-93 Modified Parameters		
Array [1,000]		
Range:	Function:	
0 *	[0 - 9999]	View a list of the parameters that have been changed from their default setting. The list ends with 0. Changes may not be visible until up to 30 s after implementation.

15-98 Drive Identification		
Range:	Function:	
0 *	[0 - 0]	

15-99 Parameter Metadata		
Array [23]		
Range:	Function:	
0 *	[0 - 9999]	This parameter contains data used by the MCT 10 Set-up Software software tool.

3.15 Parameters 16-** Data Readouts

16-00 Control Word		
Range:	Function:	
0 * [0 - 65535]	View the Control word sent from the adjustable frequency drive via the serial communication port in hex code.	

16-01 Reference [Unit]		
Range:	Function:	
0 ReferenceFeed-backUnit*	[-999999 - 999999 ReferenceFeed-backUnit]	View the present reference value applied on impulse or analog basis in the unit resulting from the configuration selected in <i>1-00 Configuration Mode</i> (Hz, Nm or RPM).

16-02 Reference [%]		
Range:	Function:	
0 %*	[-200 - 200 %]	

16-03 Status Word		
Range:	Function:	
0 * [0 - 65535]	View the Status word sent from the adjustable frequency drive via the serial communication port in hex code.	

16-05 Main Actual Value [%]		
Range:	Function:	
0 %*	[-100 - 100 %]	

16-09 Custom Readout		
Range:	Function:	
0 CustomReadoutUnit*	[-999999.99 - 999999.99 CustomReadoutUnit]	View the user-defined readouts as defined in <i>0-30 Custom Readout Unit</i> , <i>0-31 Custom Readout Min Value</i> and <i>0-32 Custom Readout Max Value</i> .

3.15.1 16-1* Motor Status

16-10 Power [kW]		
Range:	Function:	
0 kW* [0 - 10000 kW]	Displays motor power in kW. The value shown is calculated on the basis of the actual motor voltage and motor current. The value is filtered, and therefore approx. 30 ms may pass from when an input value changes to	

16-10 Power [kW]		
Range:	Function:	
		when the data readout values change. The resolution of readout value on serial communication bus is in 10 W steps.

16-11 Power [hp]		
Range:	Function:	
0 hp* [0 - 10000 hp]	View the motor power in HP. The value shown is calculated on the basis of the actual motor voltage and motor current. The value is filtered, and therefore approximately 30 ms may pass from when an input value changes to when the data readout values change.	

16-12 Motor voltage		
Range:	Function:	
0 V* [0 - 6000 V]	View the motor voltage, a calculated value used for controlling the motor.	

16-13 Frequency		
Range:	Function:	
0 Hz* [0 - 6500 Hz]	View the motor frequency, without resonance dampening.	

16-14 Motor current		
Range:	Function:	
0 A* [0 - 10000 A]	View the motor current measured as a mean value, I_{RMS} . The value is filtered, and thus approximately 30 ms may pass from when an input value changes to when the data readout values change.	

16-15 Frequency [%]		
Range:	Function:	
0 %*	[-100 - 100 %]	

16-16 Torque [Nm]		
Range:	Function:	
0 Nm* [-30000 - 30000 Nm]	View the torque value with sign, applied to the motor shaft. Linearity is not exact between 110% motor current and torque in relation to the rated torque. Some motors supply more than 160% torque. Consequently, the min. value and the max. value will depend on the max. motor current as well as the motor used. The value is filtered, and thus approx. 1.3 s may pass from when an input changes value to when the data readout values change.	

16-17 Speed [RPM]		
Range:	Function:	
0 RPM*	[-30000 - 30000 RPM]	View the current motor RPM.

16-18 Motor Thermal		
Range:	Function:	
0 %*	[0 - 100 %]	View the calculated thermal load on the motor. The cut-out limit is 100%. The basis for calculation is the ETR function selected in <i>1-90 Motor Thermal Protection</i> .

16-22 Torque [%]		
Range:	Function:	
0 %*	[-200 - 200 %]	

3.15.2 16-3* Drive Status

16-30 DC Link Voltage		
Range:	Function:	
0 V*	[0 - 10000 V]	View a measured value. The value is filtered with an 30 ms time constant.

16-32 Brake Energy /s		
Range:	Function:	
0 kW*	[0 - 10000 kW]	View the braking energy transmitted to an external brake resistor, stated as an instantaneous value.

16-33 Brake Energy /2 min		
Range:	Function:	
0 kW*	[0 - 10000 kW]	View the braking energy transmitted to an external brake resistor. The mean power is calculated on an average basis for the most recent 120 s.

16-34 Heatsink Temp.		
Range:	Function:	
0 °C*	[0 - 255 °C]	

16-35 Inverter Thermal		
Range:	Function:	
0 %*	[0 - 100 %]	View the percentage load on the inverter.

16-36 Inv. Nom. Current		
Range:	Function:	
Size related*	[0.01 - 10000 A]	

16-37 Inv. Max. Current		
Range:	Function:	
Size related*	[0.01 - 10000 A]	

16-38 SL Controller State		
Range:	Function:	
0 *	[0 - 100]	View the state of the event under execution by the SL controller.

16-39 Control Card Temp.		
Range:	Function:	
0 °C*	[0 - 100 °C]	

16-40 Logging Buffer Full		
Option:	Function:	
		View whether the logging buffer is full (see parameter group 15-1*). The logging buffer will never be full when <i>15-13 Logging Mode</i> is set to <i>[0] Log always</i> .
[0]	No	
[1]	Yes	

16-49 Current Fault Source		
Range:	Function:	
0 *	[0 - 8]	Value indicates source of current fault, including: short circuit, overcurrent and phase imbalance (from left): [1-4] Inverter, [5-8] Rectifier, [0] No fault recorded

After a short circuit alarm (I_{max2}) or overcurrent alarm (I_{max1} or phase imbalance), this will contain the power card number associated with the alarm. It only holds one number so it will indicate the highest priority power card number (master first). The value will persist on power cycle, but if a new alarm occurs it will be overwritten with the new power card number (even if it a lower priority number). The value will only be cleared when the alarm log is cleared (e.g., a 3-finger reset would reset the readout to 0).

3.15.3 16-5* Ref. & Feedb.

16-50 External Reference		
Range:	Function:	
0 *	[-200 - 200]	View the total reference, the sum of digital, analog, preset, bus and freeze references, plus catch-up and slow-down.

16-52 Feedback [Unit]		
Range:		Function:
0 ProcessCtrlUnit*	[-999999.999 - 999999.999 ProcessCtrlUnit]	View value of resulting feedback value after processing of Feedback 1-3 (see 16-54 Feedback 1 [Unit], 16-55 Feedback 2 [Unit] and 16-56 Feedback 3 [Unit]) in the feedback manager. See parameter group 20-0* Feedback. The value is limited by settings in 20-13 Minimum Reference/Feedb. and 20-14 Maximum Reference/Feedb.. Units as set in 20-12 Reference/Feedback Unit.

16-53 Digi Pot Reference		
Range:		Function:
0 *	[-200 - 200]	View the contribution of the digital potentiometer to the actual reference.

16-54 Feedback 1 [Unit]		
Range:		Function:
0 ProcessCtrlUnit*	[-999999.999 - 999999.999 ProcessCtrlUnit]	View value of Feedback 1, see parameter group 20-0* Feedback.

16-55 Feedback 2 [Unit]		
Range:		Function:
0 ProcessCtrlUnit*	[-999999.999 - 999999.999 ProcessCtrlUnit]	View value of Feedback 2, see parameter group 20-0* Feedback. The value is limited by settings in 20-13 Minimum Reference/Feedb. and 20-14 Maximum Reference/Feedb.. Units as set in 20-12 Reference/Feedback Unit.

16-56 Feedback 3 [Unit]		
Range:		Function:
0 ProcessCtrlUnit*	[-999999.999 - 999999.999 ProcessCtrlUnit]	View value of Feedback 3, see parameter group 20-0* Feedback.

16-58 PID Output [%]		
Range:		Function:
0 %*	[0 - 100 %]	

16-59 Adjusted Setpoint		
Range:		Function:
0 ProcessCtrlUnit*	[-999999.999 - 999999.999 ProcessCtrlUnit]	

3.15.4 16-6* Inputs & Outputs

16-60 Digital Input																								
Range:		Function:																						
0 *	[0 - 65535]	View the signal states from the active digital inputs. Input 18 corresponds for example to bit 5. '0' = NO signal, '1' = connected signal.																						
		<table border="1"> <tr><td>Bit 0</td><td>Digital input term. 33</td></tr> <tr><td>Bit 1</td><td>Digital input term. 32</td></tr> <tr><td>Bit 2</td><td>Digital input term. 29</td></tr> <tr><td>Bit 3</td><td>Digital input term. 27</td></tr> <tr><td>Bit 4</td><td>Digital input term. 19</td></tr> <tr><td>Bit 5</td><td>Digital input term. 18</td></tr> <tr><td>Bit 6</td><td>Digital input term. 37</td></tr> <tr><td>Bit 7</td><td>Digital input GP I/O term. X30/2</td></tr> <tr><td>Bit 8</td><td>Digital input GP I/O term. X30/3</td></tr> <tr><td>Bit 9</td><td>Digital input GP I/O term. X30/4</td></tr> <tr><td>Bit 10-63</td><td>Reserved for future terminals</td></tr> </table>	Bit 0	Digital input term. 33	Bit 1	Digital input term. 32	Bit 2	Digital input term. 29	Bit 3	Digital input term. 27	Bit 4	Digital input term. 19	Bit 5	Digital input term. 18	Bit 6	Digital input term. 37	Bit 7	Digital input GP I/O term. X30/2	Bit 8	Digital input GP I/O term. X30/3	Bit 9	Digital input GP I/O term. X30/4	Bit 10-63	Reserved for future terminals
Bit 0	Digital input term. 33																							
Bit 1	Digital input term. 32																							
Bit 2	Digital input term. 29																							
Bit 3	Digital input term. 27																							
Bit 4	Digital input term. 19																							
Bit 5	Digital input term. 18																							
Bit 6	Digital input term. 37																							
Bit 7	Digital input GP I/O term. X30/2																							
Bit 8	Digital input GP I/O term. X30/3																							
Bit 9	Digital input GP I/O term. X30/4																							
Bit 10-63	Reserved for future terminals																							
Table 3.21																								

16-61 Terminal 53 Switch Setting		
Option:		Function:
		View the setting of input terminal 53. Current = 0; Voltage = 1.
[0]	Current	
[1]	Voltage	

16-62 Analog Input 53		
Range:		Function:
0 *	[-20 - 20]	View the actual value at input 53.

16-63 Terminal 54 Switch Setting		
Option:		Function:
		View the setting of input terminal 54. Current = 0; Voltage = 1.
[0]	Current	
[1]	Voltage	

16-64 Analog Input 54		
Range:	Function:	
0 *	[-20 - 20]	View the actual value at input 54.

16-65 Analog Output 42 [mA]		
Range:	Function:	
0 *	[0 - 30]	View the actual value at output 42 in mA. The value shown reflects the selection in 6-50 Terminal 42 Output.

16-66 Digital Output [bin]		
Range:	Function:	
0 *	[0 - 15]	View the binary value of all digital outputs.

16-67 Pulse Input #29 [Hz]		
Range:	Function:	
0 *	[0 - 130000]	View the actual frequency rate on terminal 29.

16-68 Pulse Input #33 [Hz]		
Range:	Function:	
0 *	[0 - 130000]	View the actual frequency rate on terminal 33.

16-69 Pulse Output #27 [Hz]		
Range:	Function:	
0 *	[0 - 40000]	View the actual value on terminal 27 in digital output mode.

16-70 Pulse Output #29 [Hz]		
Range:	Function:	
0 *	[0 - 40000]	View the actual value of pulses on terminal 29 in digital output mode.

16-71 Relay Output [bin]		
Range:	Function:	
0 *	[0 - 511]	View the settings of all relays.

Readout choice (Par. 16-71):
Relay output (bin):

0 0 0 0 0 bin

130BA195.10

Figure 3.44

16-72 Counter A		
Range:	Function:	
0 *	[-2147483648 - 2147483647]	View the present value of Counter A. Counters are useful as comparator operands, see 13-10 Comparator Operand. The value can be reset or changed either via digital inputs (parameter group 5-1*) or by using an SLC action (13-52 SL Controller Action).

16-73 Counter B		
Range:	Function:	
0 *	[-2147483648 - 2147483647]	View the present value of Counter B. Counters are useful as comparator operands (13-10 Comparator Operand). The value can be reset or changed either via digital inputs (parameter group 5-1*) or by using an SLC action (13-52 SL Controller Action).

16-75 Analog In X30/11		
Range:	Function:	
0 *	[-20 - 20]	View the actual value at input X30/11 of MCB 101.

16-76 Analog In X30/12		
Range:	Function:	
0 *	[-20 - 20]	View the actual value at input X30/12 of MCB 101.

16-77 Analog Out X30/8 [mA]		
Range:	Function:	
0 *	[0 - 30]	View the actual value at input X30/8 in mA.

3.15.5 16-8* Fieldbus & FC Port

Parameters for reporting the BUS references and control words.

16-80 Fieldbus CTW 1		
Range:	Function:	
0 *	[0 - 65535]	View the two-byte control word (CTW) received from the bus master. Interpretation of the control word depends on the serial communication option installed and the control word profile selected in 8-10 Control Profile. For more information, refer to the relevant serial communication bus manual.

16-82 Fieldbus REF 1		
Range:	Function:	
0 * [-200 - 200]	View the two-byte word sent with the control word from the bus master to set the reference value. For more information, refer to the relevant serial communication bus manual.	

16-84 Comm. Option Status		
Range:	Function:	
0 * [0 - 65535]	View the extended ser. comm. option status word. For more information, refer to the relevant serial communication bus manual.	

16-85 FC Port CTW 1		
Range:	Function:	
0 * [0 - 65535]	View the two-byte control word (CTW) received from the bus master. Interpretation of the control word depends on the serial communication option installed and the control word profile selected in <i>8-10 Control Profile</i> .	

16-86 FC Port REF 1		
Range:	Function:	
0 * [-200 - 200]	View the two-byte status word (STW) sent to the bus master. Interpretation of the status word depends on the serial communication bus option installed and the control word profile selected in <i>8-10 Control Profile</i> .	

3.15.6 16-9* Diagnosis Readouts

16-90 Alarm Word		
Range:	Function:	
0 * [0 - 4294967295]	View the alarm word sent via the serial communication port in hex code.	

16-91 Alarm Word 2		
Range:	Function:	
0 * [0 - 4294967295]	View the alarm word 2 sent via the serial communication port in hex code.	

16-92 Warning Word		
Range:	Function:	
0 * [0 - 4294967295]	View the warning word sent via the serial communication port in hex code.	

16-93 Warning Word 2		
Range:	Function:	
0 * [0 - 4294967295]	View the warning word 2 sent via the serial communication port in hex code.	

16-94 Ext. Status Word		
Range:	Function:	
0 * [0 - 4294967295]	Returns the extended status word sent via the serial communication port in hex code.	

16-95 Ext. Status Word 2		
Range:	Function:	
0 * [0 - 4294967295]	Returns the extended warning word 2 sent via the serial communication port in hex code.	

16-96 Maintenance Word		
Range:	Function:	
0 * [0 - 4294967295]	Readout of the Preventive Maintenance Word. The bits reflect the status for the programmed preventive maintenance events in parameter group 23-1*. 13 bits represent combinations of all the possible items: <ul style="list-style-type: none"> • Bit 0: Motor bearings • Bit 1: Pump bearings • Bit 2: Fan bearings • Bit 3: Valve • Bit 4: Pressure transmitter • Bit 5: Flow transmitter • Bit 6: Temperature transmitter • Bit 7: Pump seals • Bit 8: Fan belt • Bit 9: Filter • Bit 10: Drive cooling fan • Bit 11: Drive system health check • Bit 12: Warranty • Bit 13: Maintenance Text 0 • Bit 14: Maintenance Text 1 • Bit 15: Maintenance Text 2 • Bit 16: Maintenance Text 3 • Bit 17: Maintenance Text 4 	

16-96 Maintenance Word														
Range:	Function:													
	Position 4 ⇒	Valve	Fan bearings	Pump bearings	Motor bearings									
	Position 3 ⇒	Pump seals	Temperature transmitter	Flow transmitter	Pressure transmitter									
	Position 2 ⇒	Drive system health check	Drive cooling fan	Filter	Fan belt									
	Position 1 ⇒				Warranty									
	0 _{hex}	-	-	-	-									
	1 _{hex}	-	-	-	+									
	2 _{hex}	-	-	+	-									
	3 _{hex}	-	-	+	+									
	4 _{hex}	-	+	-	-									
	5 _{hex}	-	+	-	+									
	6 _{hex}	-	+	+	-									
	7 _{hex}	-	+	+	+									
	8 _{hex}	+	-	-	-									
	9 _{hex}	+	-	-	+									
	A _{hex}	+	-	+	-									
	B _{hex}	+	-	+	+									
	C _{hex}	+	+	-	-									
	D _{hex}	+	+	-	+									
	E _{hex}	+	+	+	-									
	F _{hex}	+	+	+	+									
<p>Table 3.24</p> <p>Example: The Preventive Maintenance Word shows 040A_{hex}.</p> <table border="1"> <tr> <td>Position</td> <td>1</td> <td>2</td> <td>3</td> <td>4</td> </tr> <tr> <td>hex value</td> <td>0</td> <td>4</td> <td>0</td> <td>A</td> </tr> </table> <p>Table 3.25</p> <p>The first digit 0 indicates that no items from the fourth row requires maintenance The second digit 4 refers to the third row indicating that the drive cooling fan requires maintenance The third digit 0 indicates that no items from the second row require maintenance The fourth digit A refers to the top row indicating that the valve and the pump bearings require maintenance</p>					Position	1	2	3	4	hex value	0	4	0	A
Position	1	2	3	4										
hex value	0	4	0	A										

3.16 Parameters 18-** Data Readouts 2

3.16.1 18-0* Maintenance Log

This group contains the last ten preventive maintenance events. Maintenance Log 0 is the latest and Maintenance Log 9 the oldest.

By selecting one of the logs and pressing [OK], the Maintenance Item, Action and time of the occurrence can be found in *18-00 Maintenance Log: Item* – *18-03 Maintenance Log: Date and Time*.

The Alarm log key allows access to both Alarm log and Maintenance log.

18-00 Maintenance Log: Item		
Array [10]. Array parameter; Error code 0-9: The meaning of the error code can be found in the Troubleshooting section of the Design Guide.		
Range:	Function:	
0 *	[0 - 255]	Locate the meaning of the Maintenance Item in the description of <i>23-10 Maintenance Item</i> .

18-01 Maintenance Log: Action		
Array [10]. Array parameter; Error code 0-9: The meaning of the error code can be found in <i>Troubleshooting</i> in the Design Guide.		
Range:	Function:	
0 *	[0 - 255]	Locate the meaning of the maintenance item in the description of <i>23-11 Maintenance Action</i>

18-02 Maintenance Log: Time		
Array [10]. Array parameter; Time 0-9: This parameter shows at which time the logged event occurred. Time is measured in seconds since start of the adjustable frequency drive.		
Range:	Function:	
0 s*	[0 - 2147483647 s]	Shows when the logged event occurred. Time is measured in seconds since last power-up.

18-03 Maintenance Log: Date and Time		
Array [10]		
Range:	Function:	
Size related*	[0 - 0]	Shows when the logged event occurred. NOTICE! This requires that the date and time is programmed in <i>0-70 Date and Time</i> .

18-03 Maintenance Log: Date and Time		
Array [10]		
Range:	Function:	
	Date format depends on the setting in <i>0-71 Date Format</i> , while the time format depends on the setting in <i>0-72 Time Format</i> . NOTICE! The adjustable frequency drive has no backup of the clock function and the set date/time will reset to default (2000-01-01 00:00) after a power-down unless a real time clock module with backup is installed. In <i>0-79 Clock Fault</i> , it is possible to program a warning to be issued if the clock has not been set properly, e.g., after a power-down. Incorrect setting of the clock will affect the time stamps for the Maintenance Events.	

NOTICE!

When mounting an analog I/O MCB 109 option card, a battery backup of date and time is included.

3.16.2 18-3* Analog Readouts

18-30 Analog Input X42/1		
Range:	Function:	
0 *	[-20 - 20]	Readout of the value of the signal applied to terminal X42/1 on the analog I/O card (MCB 109). The units of the value shown in the LCP will correspond to the mode selected in <i>26-00 Terminal X42/1 Mode</i> .

18-31 Analog Input X42/3		
Range:	Function:	
0 *	[-20 - 20]	Readout of the value of the signal applied to terminal X42/3 on the analog I/O card (MCB 109). The units of the value shown in the LCP will correspond to the mode selected in <i>26-01 Terminal X42/3 Mode</i> .

18-32 Analog Input X42/5		
Range:	Function:	
0 * [-20 - 20]	Readout of the value of the signal applied to terminal X42/5 on the analog I/O card (MCB 109). The units of the value shown in the LCP will correspond to the mode selected in <i>26-02 Terminal X42/5 Mode</i> .	

18-33 Analog Out X42/7 [V]		
Range:	Function:	
0 * [0 - 30]	Readout of the value of the signal applied to terminal X42/7 on the analog I/O card (MCB 109). The value shown reflects the selection in <i>26-40 Terminal X42/7 Output</i> .	

18-34 Analog Out X42/9 [V]		
Range:	Function:	
0 * [0 - 30]	Readout of the value of the signal applied to terminal X42/9 on the analog I/O card (MCB 109). The value shown reflects the selection in <i>26-50 Terminal X42/9 Output</i> .	

18-35 Analog Out X42/11 [V]		
Range:	Function:	
0 * [0 - 30]	Readout of the value of the signal applied to terminal X42/11 on the analog I/O card (MCB 109). The value shown reflects the selection in <i>26-60 Terminal X42/11 Output</i> .	

18-36 Analog Input X48/2 [mA]		
Range:	Function:	
0 * [-20 - 20]	View the actual current measured at input X48/2 (MCB 114).	

18-37 Temp. Input X48/4		
Range:	Function:	
0 * [-500 - 500]	View the actual temperature measured at input X48/4 (MCB 114). The temperature unit is based on the selection in <i>35-00 Term. X48/4 Temp. Unit</i> .	

18-38 Temp. Input X48/7		
Range:	Function:	
0 * [-500 - 500]	View the actual temperature measured at input X48/7 (MCB 114). The temperature unit is based on the selection in <i>35-02 Term. X48/7 Temp. Unit</i> .	

18-39 Temp. Input X48/10		
Range:	Function:	
0 * [-500 - 500]	View the actual temperature measured at input X48/10 (MCB 114). The temperature unit is based on the selection in <i>35-04 Term. X48/10 Temp. Unit</i> .	

3.16.3 18-6* Inputs & Outputs 2

18-60 Digital Input 2		
Range:	Function:	
0 * [0 - 65535]	View the signal states from the active digital inputs on the MCO 102 (Advanced Cascade Controller): Counting from right to left the positions in the binary file are: DI7...DI1 ⇒ pos. 2 ...pos. 8.	

3.17 Parameters 20-** FC Closed-loop

3.17.1 20-** Drive Closed-loop

This parameter group is used for configuring the closed-loop PID controller that controls the output frequency of the adjustable frequency drive.

3.17.2 20-0* Feedback

This parameter group is used to configure the feedback signal for the adjustable frequency drive's closed-loop PID controller. Whether the adjustable frequency drive is in closed-loop mode or open-loop mode, the feedback signals can be shown on the adjustable frequency drive's display. It can also be used to control an adjustable frequency drive analog output, and to be transmitted over various serial communication protocols.

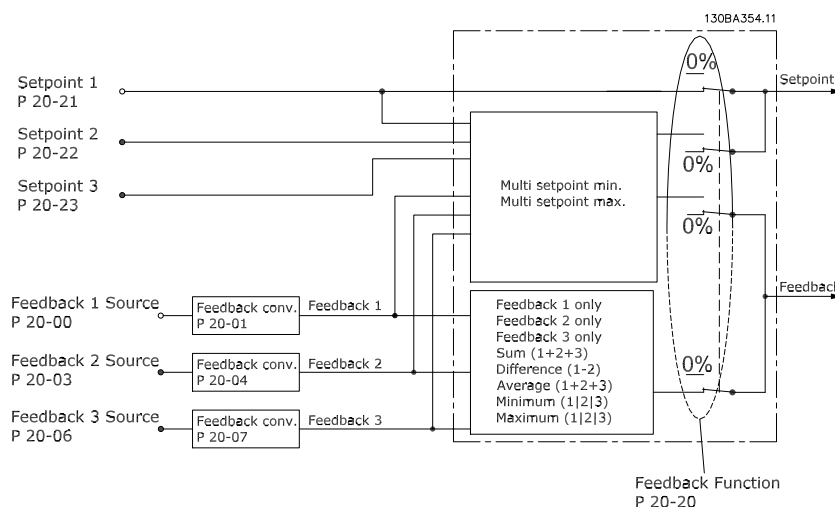

Figure 3.45

20-00 Feedback 1 Source	
Option:	Function:
[0]	No function
[1]	Analog Input 53
[2]	Analog Input 54
[3]	Pulse input 29
[4]	Pulse input 33
[7]	Analog input X30/11
[8]	Analog input X30/12
[9]	Analog Input X42/1

20-00 Feedback 1 Source		
Option:	Function:	
[10]	Analog Input X42/3	
[11]	Analog Input X42/5	
[15]	Analog Input X48/2	
[100]	Bus feedback 1	
[101]	Bus feedback 2	
[102]	Bus feedback 3	
[104]	Sensorless Flow	Requires set up by MCT 10 Set-up Software with sensorless specific plug-in.
[105]	Sensorless Pressure	Requires set up by MCT 10 Set-up Software with sensorless specific plug-in.

NOTICE!

If a feedback is not used, its source must be set to [0] *No Function*. 20-20 Feedback Function determines how the three possible feedbacks will be used by the PID Controller.

20-01 Feedback 1 Conversion		
Option:	Function:	
[0]	Linear	
[1]	Square root	This parameter allows a conversion function to be applied to Feedback 1. [0] <i>Linear</i> has no effect on the feedback. [1] <i>Square root</i> is commonly used when a pressure sensor is used to provide flow feedback ($flow \propto \sqrt{pressure}$).

20-02 Feedback 1 Source Unit		
Option:	Function:	
		This parameter determines the unit that is used for this Feedback Source, before applying the feedback conversion of 20-01 Feedback 1 Conversion. This unit is not used by the PID controller.
[0]	None	
[1]	%	
[5]	PPM	
[10]	min	
[11]	RPM	
[12]	PULSE/s	
[20]	liter / sec.	
[21]	liter / min	
[22]	liter / hr.	
[23]	m ³ / sec.	
[24]	m ³ /min	
[25]	m ³ / hr.	
[30]	kg / sec.	
[31]	kg/min	
[32]	kg / hr.	
[33]	ton / min	
[34]	ton / hr.	
[40]	m / sec.	
[41]	m/min	
[45]	m	
[60]	°C	
[70]	mbar	
[71]	bar	
[72]	Pa	
[73]	kPa	
[74]	m WG	
[75]	mm Hg	
[80]	kW	
[120]	GPM	

20-02 Feedback 1 Source Unit		
Option:	Function:	
[121]	gal / sec.	
[122]	gal/min	
[123]	gal / hr.	
[124]	CFM	
[125]	ft ³ /s	
[126]	ft ³ /min	
[127]	ft ³ /h	
[130]	lbs / sec.	
[131]	lbs / min.	
[132]	lbs / hr.	
[140]	ft/s	
[141]	ft/min	
[145]	ft	
[160]	°F	
[170]	psi	
[171]	lb/in ²	
[172]	in. wtr. gage	
[173]	ft WG	
[174]	in Hg	
[180]	HP	

NOTICE!

This parameter is only available when using pressure to temperature feedback conversion.
If the choice [0] *Linear* is selected in 20-01 Feedback 1 Conversion, then the setting of any choice in 20-02 Feedback 1 Source Unit does not matter as the conversion will be one-to-one.

20-03 Feedback 2 Source		
Option:	Function:	
		See 20-00 Feedback 1 Source for details.
[0]	No function	
[1]	Analog Input 53	
[2]	Analog Input 54	
[3]	Pulse input 29	
[4]	Pulse input 33	
[7]	Analog input X30/11	
[8]	Analog input X30/12	
[9]	Analog Input X42/1	
[10]	Analog Input X42/3	
[11]	Analog Input X42/5	
[15]	Analog Input X48/2	
[100]	Bus feedback 1	
[101]	Bus feedback 2	
[102]	Bus feedback 3	

20-04 Feedback 2 Conversion		
Option:	Function:	
		See 20-01 Feedback 1 Conversion for details.
[0]	Linear	
[1]	Square root	
[2]	Pressure to temperature	
[3]	Pressure to flow	
[4]	Velocity to flow	

20-05 Feedback 2 Source Unit		
See 20-02 Feedback 1 Source Unit for details.		
Option:	Function:	
[0] *	Linear	

20-06 Feedback 3 Source		
Option:	Function:	
		See 20-00 Feedback 1 Source for details.
[0]	No function	
[1]	Analog Input 53	
[2]	Analog Input 54	
[3]	Pulse input 29	
[4]	Pulse input 33	
[7]	Analog input X30/11	
[8]	Analog input X30/12	
[9]	Analog Input X42/1	
[10]	Analog Input X42/3	
[11]	Analog Input X42/5	
[15]	Analog Input X48/2	
[100]	Bus feedback 1	
[101]	Bus feedback 2	
[102]	Bus feedback 3	

20-07 Feedback 3 Conversion		
Option:	Function:	
		See 20-01 Feedback 1 Conversion for details.
[0]	Linear	
[1]	Square root	
[2]	Pressure to temperature	
[3]	Pressure to flow	
[4]	Velocity to flow	

20-08 Feedback 3 Source Unit		
See 20-02 Feedback 1 Source Unit for details.		
Option:	Function:	
[0]	None	
[1]	%	
[5]	PPM	
[10]	min	

20-08 Feedback 3 Source Unit		
See 20-02 Feedback 1 Source Unit for details.		
Option:	Function:	
[11]	RPM	
[12]	PULSE/s	
[20]	liter / sec.	
[21]	liter / min	
[22]	liter / hr.	
[23]	m ³ / sec.	
[24]	m ³ /min	
[25]	m ³ / hr.	
[30]	kg / sec.	
[31]	kg/min	
[32]	kg / hr.	
[33]	ton / min	
[34]	ton / hr.	
[40]	m / sec.	
[41]	m/min	
[45]	m	
[60]	°C	
[70]	mbar	
[71]	bar	
[72]	Pa	
[73]	kPa	
[74]	m WG	
[75]	mm Hg	
[80]	kW	
[120]	GPM	
[121]	gal / sec.	
[122]	gal/min	
[123]	gal / hr.	
[124]	CFM	
[125]	ft ³ /s	
[126]	ft ³ /min	
[127]	ft ³ /h	
[130]	lbs / sec.	
[131]	lbs / min.	
[132]	lbs / hr.	
[140]	ft/s	
[141]	ft/min	
[145]	ft	
[160]	°F	
[170]	psi	
[171]	lb/in ²	
[172]	in. wtr. gage	
[173]	ft WG	
[174]	in Hg	
[180]	HP	

20-12 Reference/Feedback Unit	
Option:	Function:
[0]	-
[1]	%
[5]	PPM
[10]	min
[11]	RPM
[12]	PULSE/s
[20]	liter / sec.
[21]	liter / min
[22]	liter / hr.
[23]	m ³ / sec.
[24]	m ³ /min
[25]	m ³ / hr.
[30]	kg / sec.
[31]	kg/min
[32]	kg / hr.
[33]	ton / min
[34]	ton / hr.
[40]	m / sec.
[41]	m/min
[45]	m
[60]	°C
[70]	mbar
[71]	bar
[72]	Pa
[73]	kPa
[74]	m WG
[75]	mm Hg
[80]	kW
[120]	GPM
[121]	gal / sec.
[122]	gal/min
[123]	gal / hr.
[124]	CFM
[125]	ft ³ /s
[126]	ft ³ /min
[127]	ft ³ /h
[130]	lbs / sec.
[131]	lbs / min.
[132]	lbs / hr.
[140]	ft/s
[141]	ft/min
[145]	ft
[160]	°F
[170]	psi
[171]	lb/in ²
[172]	in. wtr. gage
[173]	ft WG
[174]	in Hg
[180]	HP This parameter determines the unit that is used for the setpoint reference and feedback

20-12 Reference/Feedback Unit	
Option:	Function:
	that the PID controller will use for controlling the output frequency of the adjustable frequency drive.

3.17.3 20-2* Feedback & Setpoint

This parameter group is used to determine how the adjustable frequency drive's PID controller will use the three possible feedback signals to control the output frequency of the adjustable frequency drive. This group is also used to store the three internal setpoint references.

20-20 Feedback Function

This parameter determines how the three possible feedbacks will be used to control the output frequency of the adjustable frequency drive.

NOTICE!

Any unused feedback must be set to "No function" in its Feedback Source 20-00 Feedback 1 Source, 20-03 Feedback 2 Source or 20-06 Feedback 3 Source.

The feedback resulting from the function selected in 20-20 Feedback Function will be used by the PID controller to control the output frequency of the adjustable frequency drive. This feedback can also be shown on the adjustable frequency drive's display, be used to control an adjustable frequency drive's analog output, and be transmitted over various serial communication protocols.

The adjustable frequency drive can be configured to handle multi-zone applications. Two different multi-zone applications are supported:

- Multi-zone, single setpoint
- Multi-zone, multi setpoint

The difference between the two is illustrated by the following examples:

Example 1: Multi-zone, single setpoint

In an office building, a VAV (variable air volume) water system must ensure a minimum pressure at selected VAV boxes. Due to the varying pressure losses in each duct, the pressure at each VAV box cannot be assumed to be the same. The minimum pressure required is the same for all VAV boxes. This control method can be set up by setting Feedback Function, 20-20 Feedback Function to option [3] Minimum and entering the desired pressure in 20-21 Setpoint 1. The PID controller will increase the speed of the fan if any one feedback is below the setpoint, and

decrease the speed of the fan if all feedbacks are above the setpoint.

3

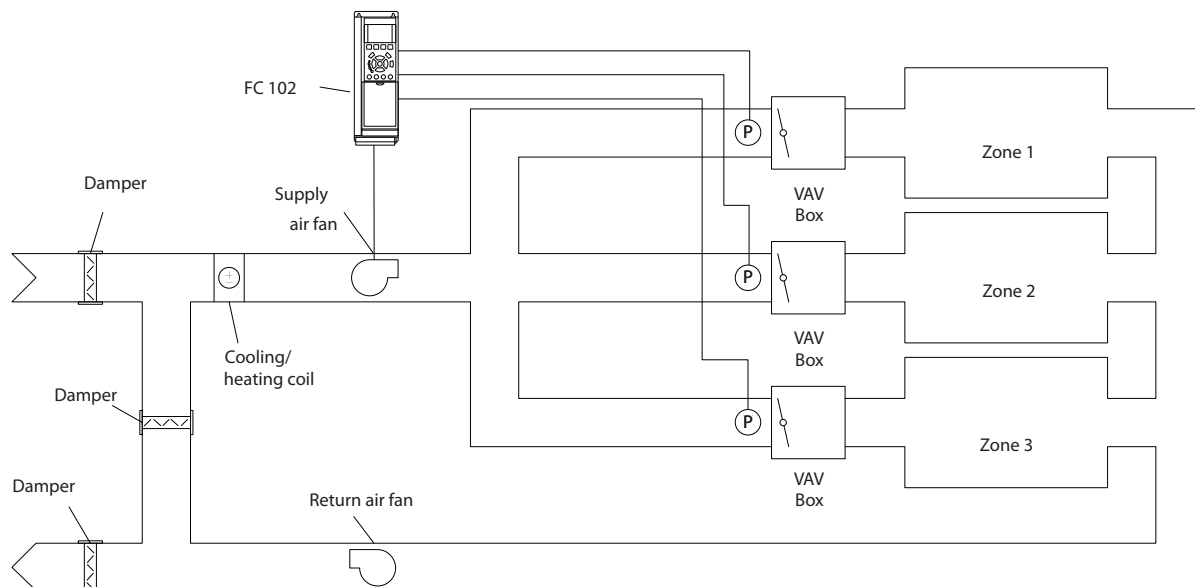

Figure 3.46

Example 2: Multi-zone, multi setpoint

The previous example can be used to illustrate the use of multi-zone, multi-setpoint control. If the zones require different pressures for each VAV box, each setpoint may be specified in 20-21 Setpoint 1, 20-22 Setpoint 2 and 20-23 Setpoint 3. By selecting [5] Multi setpoint minimum in 20-20 Feedback Function, the PID controller will increase the speed of the fan if any one of the feedback results is below its setpoint and decrease the speed of the fan if all feedback results are above their individual setpoints.

20-20 Feedback Function		
Option:	Function:	
[0]	Sum	[0] Sum sets up the PID controller to use the sum of Feedback 1, Feedback 2 and Feedback 3 as the feedback. The sum of Setpoint 1 and any other references that are enabled (see parameter group 3-1* References) will be used as the PID Controller's setpoint reference.
[1]	Difference	[1] Difference sets up the PID controller to use the difference between Feedback 1 and Feedback 2 as the feedback. Feedback 3 will not be used with this selection. Only setpoint 1 will be used. The sum of Setpoint 1 and any other references that are enabled (see parameter group 3-1*) will be used as the PID controller's setpoint reference.

20-20 Feedback Function		
Option:	Function:	
[2]	Average	Sets up the PID controller to use the average of Feedback 1, Feedback 2 and Feedback 3 as the feedback.
[3]	Minimum	Sets up the PID controller to compare Feedback 1, Feedback 2 and Feedback 3 and use the lowest value as the feedback. Only setpoint 1 will be used. The sum of Setpoint 1 and any other references that are enabled (see parameter group 3-1* References) will be used as the PID Controller's setpoint reference.
[4]	Maximum	Sets up the PID controller to compare Feedback 1, Feedback 2 and Feedback 3 and use the highest value as the feedback. Only Setpoint 1 will be used. The sum of Setpoint 1 and any other references that are enabled (see parameter group 3-1* References) will be used as the PID Controller's setpoint reference.
[5]	Multi Setpoint Min	Sets up the PID controller to calculate the difference between Feedback 1 and Setpoint 1, Feedback 2 and Setpoint 2, and Feedback 3 and Setpoint 3. It will use the feedback/setpoint pair in which the feedback is the farthest below its corresponding setpoint reference. If all feedback signals are above their corresponding setpoints,

20-20 Feedback Function		
Option:	Function:	
	<p>the PID Controller will use the feedback/setpoint pair in which the difference between the feedback and setpoint is the least.</p> <p>NOTICE! If only two feedback signals are used, the feedback that is not to be used must be set to <i>No Function</i> in <i>20-00 Feedback 1 Source</i>, <i>20-03 Feedback 2 Source</i>, or <i>20-06 Feedback 3 Source</i>. Note that each setpoint reference will be the sum of its respective parameter value and any other references that are enabled (see parameter group <i>3-1* References</i>).</p>	
[6] Multi Setpoint Max	<p>[6] <i>Multi-setpoint maximum</i> sets up the PID controller to calculate the difference between Feedback 1 and Setpoint 1, Feedback 2 and Setpoint 2, and Feedback 3 and Setpoint 3. It will use the feedback/setpoint pair in which the feedback is farthest above its corresponding setpoint reference. If all feedback signals are below their corresponding setpoints, the PID Controller will use the feedback/setpoint pair in which the difference between the feedback and the setpoint reference is the least.</p> <p>NOTICE! If only two feedback signals are used, the feedback that is not to be used must be set to <i>No Function</i> in <i>20-00 Feedback 1 Source</i>, <i>20-03 Feedback 2 Source</i>, or <i>20-06 Feedback 3 Source</i>. Note that each setpoint reference will be the sum of its respective parameter value (<i>20-21 Setpoint 1</i>, <i>20-22 Setpoint 2</i> and <i>20-23 Setpoint 3</i>) and any other references that are enabled (see parameter group <i>3-1* References</i>).</p>	

20-21 Setpoint 1		
Range:	Function:	
0 ProcessCtrlUnit*	[-999999.999 - 999999.999 ProcessCtrlUnit]	Setpoint 1 is used in Closed-loop mode to enter a setpoint reference that is used by the adjustable frequency drive's PID controller. See the description of <i>20-20 Feedback Function</i> .

20-21 Setpoint 1		
Range:	Function:	
	<p>NOTICE! Setpoint reference entered here is added to any other references that are enabled (see parameter group <i>3-1*</i>).</p>	

20-22 Setpoint 2		
Range:	Function:	
0 ProcessCtrlUnit*	[-999999.999 - 999999.999 ProcessCtrlUnit]	Setpoint 2 is used in Closed-loop mode to enter a setpoint reference that may be used by the adjustable frequency drive's PID controller. See the description of <i>Feedback Function</i> , <i>20-20 Feedback Function</i> .

NOTICE!
The setpoint reference entered here is added to any other references that are enabled (see parameter group *3-1**).

20-23 Setpoint 3		
Range:	Function:	
0 ProcessCtrlUnit*	[-999999.999 - 999999.999 ProcessCtrlUnit]	Setpoint 3 is used in Closed-loop mode to enter a setpoint reference that may be used by the adjustable frequency drive's PID controller. See the description of <i>20-20 Feedback Function</i> .
	<p>NOTICE! If the min and max references are altered, a new PI - Auto-tune may be needed.</p> <p>NOTICE! The setpoint reference entered here is added to any other references that are enabled (see parameter group <i>3-1* References</i>).</p>	

3.17.4 20-7* PID autotuning

The adjustable frequency drive PID Closed-loop controller (parameter group 20-**, *FC Drive Closed-loop*) can be auto-tuned, simplifying and saving time during commissioning, while ensuring accurate PID control adjustment. To use auto-tuning, it is necessary for the adjustable frequency drive to be configured for closed-loop in *1-00 Configuration Mode*.

A Graphical Local Control Panel (LCP) must be used in order to react to messages during the auto-tuning sequence.

Enabling *20-79 PID Autotuning*, puts the adjustable frequency drive into auto-tuning mode. The LCP then directs the user with on-screen instructions.

The fan/pump is started by pressing [Auto On] and applying a start signal. The speed is adjusted manually by pressing [▲] or [▼] to a level where the feedback is around the system setpoint.

NOTICE!

It is not possible to run the motor at maximum or minimum speed when manually adjusting the motor speed, due to the need to give the motor a step in the speed during auto-tuning.

PID auto-tuning functions by introducing step changes whilst operating at a steady state and then monitoring the feedback. From the feedback response, the required values for *20-93 PID Proportional Gain* and *20-94 PID Integral Time* are calculated. *20-95 PID Differentiation Time* is set to value 0 (zero). *20-81 PID Normal/ Inverse Control* is determined during the tuning process.

These calculated values are displayed on the LCP, and the user can decide whether to accept or reject them. Once accepted, the values are written to the relevant parameters and auto-tuning mode is disabled in *20-79 PID Autotuning*. Depending on the system being controlled, the time required to carry out auto-tuning could be several minutes. It is advised to set the ramp times in *3-41 Ramp 1 Ramp-up Time*, *3-42 Ramp 1 Ramp-down Time* or *3-51 Ramp 2 Ramp-up Time* and *3-52 Ramp 2 Ramp-down Time* according to the load inertia before carrying out PID auto-tuning. If PID auto-tuning is carried out with slow ramp times, the auto-tuned parameters will typically result in very slow control. Excessive feedback sensor noise should be removed using the input filter (parameter groups 6-**, 5-5* and 26-**, Terminal 53/54 Filter Time Constant/Pulse Filter Time Constant #29/33) before activating PID auto-tuning. In

order to obtain the most accurate controller parameters, it is advisable to carry out PID autotuning, when the application is running in typical operation, i.e., with a typical load.

20-70 Closed-loop Type		
Option:	Function:	
		This parameter defines the application response. The default mode should be sufficient for most applications. If the application response speed is known, it can be selected here. This will decrease the time needed for carrying out PID autotuning. The setting has no impact on the value of the tuned parameters and is used only for the autotuning sequence.
[0]	Auto	
[1]	Fast Pressure	
[2]	Slow Pressure	
[3]	Fast Temperature	
[4]	Slow Temperature	

20-71 PID Performance		
Option:	Function:	
[0]	Normal	Normal setting of this parameter will be suitable for pressure control in fan systems.
[1]	Fast	Fast setting would generally be used in pumping systems, where a faster control response is desirable.

20-72 PID Output Change		
Range:	Function:	
0.10 *	[0.01 - 0.50]	This parameter sets the magnitude of step change during auto-tuning. The value is a percentage of full speed, i.e., if maximum output frequency in <i>4-13 Motor Speed High Limit [RPM]/4-14 Motor Speed High Limit [Hz]</i> is set to 50 Hz, 0.10 is 10% of 50 Hz, which is 5 Hz. This parameter should be set to a value resulting in feedback changes of between 10% and 20% for best tuning accuracy.

20-73 Minimum Feedback Level		
Range:	Function:	
-999999 ProcessCtrlUnit*	[-999999.999 - par. 20-74 ProcessCtrlUnit]	The minimum allowable feedback level should be entered here in user units as defined in <i>20-12 Reference/Feedback Unit</i> . If the level falls below <i>20-73 Minimum Feedback Level</i> , auto-tuning is aborted and an error message appears in the LCP.

20-74 Maximum Feedback Level		
Range:	Function:	
999999 ProcessCtrlUnit*	[par. 20-73 - 999999.999 ProcessCtrlUnit]	The maximum allowable feedback level should be entered here in user units as defined in <i>20-12 Reference/Feedback Unit</i> . If the level rises above <i>20-74 Maximum Feedback Level</i> , auto-tuning is aborted and an error message appears in the LCP.

20-79 PID Autotuning		
Option:	Function:	
		This parameter starts the PID auto-tuning sequence. Once the auto-tuning has successfully completed and the settings have been accepted or rejected by the user, by pressing [OK] or [Cancel] at the end of tuning, this parameter is reset to [0] <i>Disabled</i> .
[0]	Disabled	
[1]	Enabled	

3.17.5 20-8* PID Basic Settings

This parameter group is used to configure the basic operation of the adjustable frequency drive's PID controller, including how it responds to a feedback that is above or below the setpoint, the speed at which it first starts functioning, and when it will indicate that the system has reached the setpoint.

20-81 PID Normal/ Inverse Control		
Option:	Function:	
[0]	Normal	[0] <i>Normal</i> causes the adjustable frequency drive's output frequency to decrease when the feedback is greater than the setpoint reference. This is common

20-81 PID Normal/ Inverse Control		
Option:	Function:	
		for pressure-controlled supply fan and pump applications.
[1]	Inverse	[1] <i>Inverse</i> causes the adjustable frequency drive's output frequency to increase when the feedback is greater than the setpoint reference.

20-82 PID Start Speed [RPM]		
Range:	Function:	
Size related* [0 - par. 4-13 RPM]		When the adjustable frequency drive is first started, it initially ramps up to this output speed in open-loop mode, following the active ramp-up time. When the output speed programmed here is reached, the adjustable frequency drive will automatically switch to closed-loop mode and the PID controller will begin to function. This is useful in applications in which the driven load must first quickly accelerate to a minimum speed when it is started.
<p>NOTICE! This parameter will only be visible if <i>0-02 Motor Speed Unit</i> is set to [0] RPM.</p>		

20-83 PID Start Speed [Hz]		
Range:	Function:	
Size related* [0 - par. 4-14 Hz]		When the adjustable frequency drive is first started, it initially ramps up to this output frequency in open-loop mode, following the active ramp-up time. When the output frequency programmed here is reached, the adjustable frequency drive will automatically switch to closed-loop mode and the PID controller will begin to function. This is useful in applications in which the driven load must first quickly accelerate to a minimum speed when it is started.
<p>NOTICE! This parameter will only be visible if <i>0-02 Motor Speed Unit</i> is set to [1] Hz.</p>		

20-84 On Reference Bandwidth		
Range:	Function:	
5 %*	[0 - 200 %]	

3.17.6 20-9* PID Controller

This group provides the ability to manually adjust this PID controller. By adjusting the PID controller parameters, the control performance may be improved. See the *Introduction to VLT AQUA Drive* in the *VLT AQUA Drive Design Guide, MG20N* for guidelines on adjusting the PID Controller parameters.

20-91 PID Anti Windup		
Option:	Function:	
[0]	Off	[0] Off The integrator will continue to change value also after output has reached one of the extremes. This can afterwards cause a delay of change of the output of the controller.
[1]	On	[1] On The integrator will be locked if the output of the built-in PID controller has reached one of the extremes (min or max value) and therefore not able to add further change to the value of the process parameter controlled. This allows the controller to respond more quickly when it again can control the system.

20-93 PID Proportional Gain		
Range:	Function:	
0.50 *	[0 - 10]	The proportional gain indicates the number of times the error between the setpoint and the feedback signal is to be applied.

If (Error x Gain) jumps with a value equal to what is set in 3-03 *Maximum Reference*, the PID controller will try to change the output speed equal to what is set in 4-13 *Motor Speed High Limit [RPM]*/4-14 *Motor Speed High Limit [Hz]* but in practice of course limited by this setting. The proportional band (error causing output to change from 0–100%) can be calculated by means of the formula:

$$\left(\frac{1}{\text{Proportional Gain}} \right) \times (\text{Max Reference})$$

NOTICE!

Always set the desired value for 3-03 *Maximum Reference* before setting the values for the PID Controller in parameter group 20-9* *PID Controller*.

20-94 PID Integral Time		
Range:	Function:	
20 s*	[0.01 - 10000 s]	Over time, the integrator accumulates a contribution to the output from the PID controller as long as there is a deviation between the reference/setpoint and feedback signals. The contribution is proportional to the size of the deviation. This ensures that the deviation (error) approaches zero.

20-94 PID Integral Time		
Range:	Function:	
		Quick response on any deviation is obtained when the integral time is set to a low value. Setting it too low, however, may cause the control to become unstable. The value set is the time needed for the integrator to add the same contribution as the proportional for a certain deviation. If the value is set to 10,000, the controller will act as a pure proportional controller with a P-band based on the value set in 20-93 <i>PID Proportional Gain</i> . When no deviation is present, the output from the proportional controller will be 0.
8 s*	[0.01 - 10000 s]	

20-95 PID Differentiation Time		
Range:	Function:	
0 s*	[0 - 10 s]	The differentiator monitors the rate of change of the feedback. If the feedback is changing quickly, it will adjust the output of the PID controller to reduce the rate of change of the feedback. Quick PID controller response is obtained when this value is large. However, if a value that is too large is used, the adjustable frequency drive's output frequency may become unstable. Differentiation time is useful in situations where extremely fast adjustable frequency drive response and precise speed control are required. It can be difficult to adjust this for proper system control. Differentiation time is not commonly used in water/waste water applications. Therefore, it is generally best to leave this parameter at 0 or OFF.

20-96 PID Diff. Gain Limit		
Range:	Function:	
5 *	[1 - 50]	The differential function of a PID controller responds to the rate of change of the feedback. As a result, an abrupt change in the feedback can cause the differential function to make a very large change in the PID controller's output. This parameter limits the maximum effect that the PID controller's differential function can produce. A smaller value reduces the maximum effect of the PID controller's differential function. This parameter is only active when 20-95 <i>PID Differentiation Time</i> is not set to OFF (0 s).

3.18 Parameters 21-** Extended Closed Loop

The offers three extended closed-loop PID controllers in addition to the PID controller. These can be configured independently to control either external servos (valves, dampers, etc.) or be used together with the internal PID controller to improve the dynamic responses to setpoint changes or load disturbances.

The extended closed-loop PID controllers may be interconnected or connected to the PID closed-loop controller to form a dual loop configuration.

In order to control a modulating device (e.g., a valve motor), this device must be a positioning servo-motor with built-in electronics which accepts either a 0–10 V (signal from analog I/O card MCB 109) or a 0/4–20 mA (signal from the control card and/or general purpose I/O card MCB 101) control signal.

The output function can be programmed in the following parameters:

- Control Card, terminal 42: *6-50 Terminal 42 Output* (setting [113]...[115] or [149]...[151], Ext. Closed-loop 1/2/3
- General Purpose I/O card MCB 101, terminal X30/8: *6-60 Terminal X30/8 Output*, (setting [113]...[115] or [149]...[151], Ext. Closed-loop 1/2/3
- Analog I/O card MCB 109, terminal X42/7...11: *26-40 Terminal X42/7 Output, 26-50 Terminal X42/9 Output, 26-60 Terminal X42/11 Output* (setting [113]...[115], Ext. Closed-loop 1/2/3

The general purpose I/O card and the analog I/O card are optional cards.

3.18.1 21-0* Extended CL autotuning

The extended PID Closed-loop PID controllers can each be auto-tuned, simplifying and saving time during commissioning, while ensuring accurate PID control adjustment.

To use PID autotuning it is necessary for the relevant extended PID controller to have been configured for the application.

A graphical Local Control Panel (LCP) must be used in order to react to messages during the autotuning sequence.

Enabling autotuning *21-09 PID Autotuning* puts the relevant PID controller into PID autotuning mode. The LCP then directs the user with on-screen instructions.

PID autotuning functions by introducing step changes and then monitoring the feedback. From the feedback response, the required values for PID Proportional Gain, *21-21 Ext. 1 Proportional Gain* for EXT CL 1, *21-41 Ext. 2 Proportional Gain* for EXT CL 2 and *21-61 Ext. 3 Proportional Gain* for EXT CL 3 and Integral Time, *21-22 Ext. 1 Integral Time* for EXT CL 1, *21-42 Ext. 2 Integral Time* for EXT CL 2 and *21-62 Ext. 3 Integral Time* for EXT CL 3 are calculated. PID Differentiation Time, *21-23 Ext. 1 Differentiation Time* for EXT CL 1, *21-43 Ext. 2 Differentiation Time* for EXT CL 2 and *21-63 Ext. 3 Differentiation Time* for EXT CL 3 are set to value 0 (zero). Normal/Inverse, *21-20 Ext. 1 Normal/Inverse Control* for EXT CL 1, *21-40 Ext. 2 Normal/Inverse Control* for EXT CL 2 and *21-60 Ext. 3 Normal/Inverse Control* for EXT CL 3 are determined during the tuning process.

These calculated values are displayed on the LCP, and the user can decide whether to accept or reject them. Once accepted, the values are written to the relevant parameters and PID autotuning mode is disabled in *21-09 PID Autotuning*. Depending on the system being controlled the time required to carry out PID autotuning could be several minutes.

Excessive feedback sensor noise should be removed using the input filter (parameter groups 5-5*, 6-**, and 26-**, Terminal 53/54 Filter Time Constant/Pulse Filter Time Constant #29/33) before activating PID autotuning.

21-00 Closed-loop Type	
Option:	Function:
[0]	Auto
[1]	Fast Pressure
[2]	Slow Pressure
[3]	Fast Temperature
[4]	Slow Temperature

21-01 PID Performance		
Option:	Function:	
[0]	Normal	Normal setting of this parameter will be suitable for pressure control in fan systems.
[1]	Fast	Fast setting would generally be used in pumping systems, where a faster control response is desirable.

21-02 PID Output Change		
Range:	Function:	
0.10 *	[0.01 - 0.50]	This parameter sets the magnitude of step change during auto-tuning. The value is a percentage of full operating range. This means that if maximum analog output voltage is set to 10 V, 0.10 is 10% of 10 V, which is 1 V. This parameter should be set to a value resulting in feedback changes of between 10% and 20% for best tuning accuracy.

21-03 Minimum Feedback Level		
Range:	Function:	
-999999 *	[-999999.999 - par. 21-04]	The minimum allowable feedback level should be entered here in user units as defined in 21-10 Ext. 1 Ref./Feedback Unit for EXT CL 1, 21-30 Ext. 2 Ref./Feedback Unit for EXT CL 2 or 21-50 Ext. 3 Ref./Feedback Unit for EXT CL 3. If the level falls below 21-03 Minimum Feedback Level, PID autotuning is aborted and an error message will appear on the LCP.

21-04 Maximum Feedback Level		
Range:	Function:	
999999 *	[par. 21-03 - 999999.999]	The maximum allowable feedback level should be entered here in user units as defined in 21-10 Ext. 1 Ref./Feedback Unit for EXT CL 1, 21-30 Ext. 2 Ref./Feedback Unit for EXT CL 2 or 21-50 Ext. 3 Ref./Feedback Unit for EXT CL 3. If the level rises above 21-04 Maximum Feedback Level, PID autotuning is aborted and an error message will appear on the LCP.

21-09 PID Autotuning		
Option:	Function:	
		This parameter enables selection of the Extended PID controller to be auto-tuned and starts the PID auto-tuning for that controller. Once the auto-tuning has successfully completed and the settings have been accepted or rejected by the

21-09 PID Autotuning		
Option:	Function:	
		user, by pressing [OK] or [Cancel] at the end of tuning, this parameter is reset to [0] Disabled.
[0]	Disabled	
[1]	Enabled Ext CL1 PID	
[2]	Enabled Ext CL 2 PID	
[3]	Enabled Ext CL 3 PID	

3.18.2 21-1* Closed-loop 1 Ref/Feedback

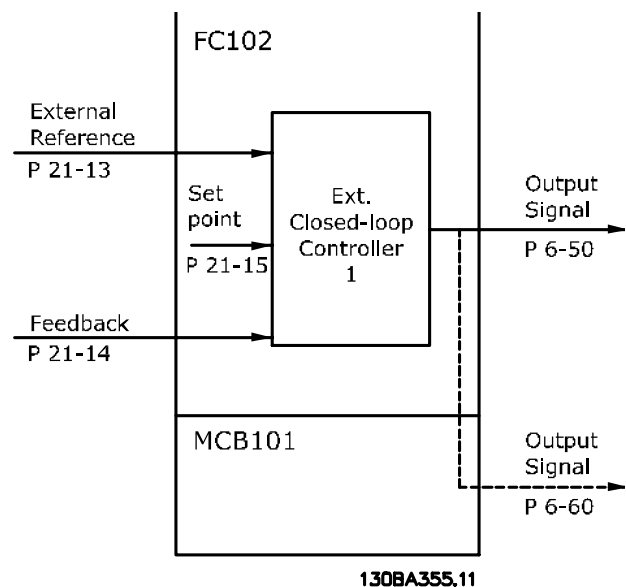

Figure 3.47

21-10 Ext. 1 Ref./Feedback Unit		
Option:	Function:	
		Select the unit for the reference and feedback.
[0]	None	
[1]	%	
[5]	PPM	
[10]	min	
[11]	RPM	
[12]	PULSE/s	
[20]	liter / sec.	
[21]	liter / min	
[22]	liter / hr.	
[23]	m ³ / sec.	
[24]	m ³ /min	

21-10 Ext. 1 Ref./Feedback Unit	
Option:	Function:
[25]	m ³ / hr.
[30]	kg / sec.
[31]	kg/min
[32]	kg / hr.
[33]	ton / min
[34]	ton / hr.
[40]	m / sec.
[41]	m/min
[45]	m
[60]	°C
[70]	mbar
[71]	bar
[72]	Pa
[73]	kPa
[74]	m WG
[75]	mm Hg
[80]	kW
[120]	GPM
[121]	gal / sec.
[122]	gal/min
[123]	gal / hr.
[124]	CFM
[125]	ft ³ /s
[126]	ft ³ /min
[127]	ft ³ /h
[130]	lbs / sec.
[131]	lbs / min.
[132]	lbs / hr.
[140]	ft/s
[141]	ft/min
[145]	ft
[160]	°F
[170]	psi
[171]	lb/in ²
[172]	in. wtr. gage
[173]	ft WG
[174]	in Hg
[180]	HP

21-11 Ext. 1 Minimum Reference	
Range:	Function:
0 ExtPID1Unit*	[-999999.999 - par. 21-12 ExtPID1Unit] Select the minimum for the closed-loop 1 controller.

21-12 Ext. 1 Maximum Reference	
Range:	Function:
100 ExtPID1Unit*	[par. 21-11 - 999999.999 ExtPID1Unit] Select the maximum for the Closed-loop 1 Controller. The dynamics of the PID controller will depend on the value set in this parameter. See also 21-21 Ext. 1 Proportional Gain.

NOTICE!

Always set the desired value for 21-12 Ext. 1 Maximum Reference before setting the values for the PID controller in parameter group 20-9*.

21-13 Ext. 1 Reference Source	
Option:	Function:
	This parameter defines which input on the adjustable frequency drive should be treated as the source of the reference signal for the closed-loop 1 controller. Analog input X30/11 and Analog input X30/12 refer to inputs on the General Purpose I/O.
[0]	No function
[1]	Analog Input 53
[2]	Analog Input 54
[7]	Pulse input 29
[8]	Pulse input 33
[20]	Digital pot.meter
[21]	Analog input X30/11
[22]	Analog input X30/12
[23]	Analog Input X42/1
[24]	Analog Input X42/3
[25]	Analog Input X42/5
[29]	Analog Input X48/2
[30]	Ext. Closed-loop 1
[31]	Ext. Closed-loop 2
[32]	Ext. Closed-loop 3

21-14 Ext. 1 Feedback Source		
Option:	Function:	
		This parameter defines which input on the adjustable frequency drive should be treated as the source of the feedback signal for the closed-loop 1 controller. Analog input X30/11 and Analog input X30/12 refer to inputs on the General Purpose I/O.
[0]	No function	
[1]	Analog Input 53	
[2]	Analog Input 54	
[3]	Pulse input 29	
[4]	Pulse input 33	
[7]	Analog input X30/11	
[8]	Analog input X30/12	
[9]	Analog Input X42/1	
[10]	Analog Input X42/3	
[11]	Analog Input X42/5	
[15]	Analog Input X48/2	
[100]	Bus feedback 1	
[101]	Bus feedback 2	
[102]	Bus feedback 3	

21-15 Ext. 1 Setpoint		
Range:	Function:	
0 ExtPID1Unit*	[par. 21-11 - par. 21-12 ExtPID1Unit]	The setpoint reference is used in extended 1 closed-loop. Ext.1 Setpoint is added to the value from the Ext.1 Reference source selected in 21-13 Ext. 1 Reference Source.

21-17 Ext. 1 Reference [Unit]		
Range:	Function:	
0 ExtPID1Unit*	[-999999.999 - 999999.999 ExtPID1Unit]	Readout of the reference value for the closed-loop 1 controller.

21-18 Ext. 1 Feedback [Unit]		
Range:	Function:	
0 ExtPID1Unit*	[-999999.999 - 999999.999 ExtPID1Unit]	Readout of the feedback value for the closed-loop 1 controller.

21-19 Ext. 1 Output [%]		
Range:	Function:	
0 %*	[0 - 100 %]	Readout of the output value for the closed-loop 1 controller.

3.18.3 21-2* Closed-loop 1 PID

21-20 Ext. 1 Normal/Inverse Control		
Option:	Function:	
[0]	Normal	Select [0] Normal if the output should be reduced when feedback is higher than the reference.
[1]	Inverse	Select [1] Inverse if the output should be increased when feedback is higher than the reference.

21-21 Ext. 1 Proportional Gain		
Range:	Function:	
0.01 *	[0 - 10]	The proportional gain indicates the number of times the error between the setpoint and the feedback signal is to be applied.

If (Error x Gain) jumps with a value equal to what is set in 3-03 *Maximum Reference*, the PID controller will try to change the output speed equal to what is set in 4-13 *Motor Speed High Limit [RPM]*/4-14 *Motor Speed High Limit [Hz]* but in practice of course limited by this setting. The proportional band (error causing output to change from 0–100%) can be calculated by means of the formula:

$$\left(\frac{1}{\text{Proportional Gain}}\right) \times (\text{Max Reference})$$

NOTICE!

Always set the desired value for 3-03 *Maximum Reference* before setting the values for the PID controller in parameter group 20-9*.

21-22 Ext. 1 Integral Time		
Range:	Function:	
10000 s*	[0.01 - 10000 s]	

21-23 Ext. 1 Differentiation Time		
Range:	Function:	
0 s*	[0 - 10 s]	The differentiator does not react to a constant error. It only provides a gain when the feedback changes. The quicker the feedback changes, the stronger the gain from the differentiator.

21-24 Ext. 1 Dif. Gain Limit		
Range:	Function:	
5 *	[1 - 50]	Set a limit for the differentiator gain (DG). The DG will increase if there are fast changes. Limit the DG to obtain a pure differentiator gain at slow changes and a constant differentiator gain where quick changes occur.

3.18.4 21-3* Closed-loop 2 Ref./Fb.

21-30 Ext. 2 Ref./Feedback Unit	
Option:	Function:
	See 21-10 Ext. 1 Ref./Feedback Unit for details
[0]	None
[1]	%
[5]	PPM
[10]	min
[11]	RPM
[12]	PULSE/s
[20]	liter / sec.
[21]	liter / min
[22]	liter / hr.
[23]	m ³ / sec.
[24]	m ³ /min
[25]	m ³ / hr.
[30]	kg / sec.
[31]	kg/min
[32]	kg / hr.
[33]	ton / min
[34]	ton / hr.
[40]	m / sec.
[41]	m/min
[45]	m
[60]	°C
[70]	mbar
[71]	bar
[72]	Pa
[73]	kPa
[74]	m WG
[75]	mm Hg
[80]	kW
[120]	GPM
[121]	gal / sec.
[122]	gal/min
[123]	gal / hr.
[124]	CFM
[125]	ft ³ /s
[126]	ft ³ /min
[127]	ft ³ /h
[130]	lbs / sec.
[131]	lbs / min.
[132]	lbs / hr.
[140]	ft/s
[141]	ft/min
[145]	ft
[160]	°F
[170]	psi
[171]	lb/in ²
[172]	in. wtr. gage

21-30 Ext. 2 Ref./Feedback Unit	
Option:	Function:
[173]	ft WG
[174]	in Hg
[180]	HP

21-31 Ext. 2 Minimum Reference		
Range:	Function:	
0 ExtPID2Unit*	[-999999.999 - par. 21-32 ExtPID2Unit]	See 21-11 Ext. 1 Minimum Reference for details.

21-32 Ext. 2 Maximum Reference		
Range:	Function:	
100 ExtPID2Unit*	[par. 21-31 - 999999.999 ExtPID2Unit]	See 21-12 Ext. 1 Maximum Reference for details.

21-33 Ext. 2 Reference Source	
Option:	Function:
	See 21-13 Ext. 1 Reference Source for details.
[0]	No function
[1]	Analog Input 53
[2]	Analog Input 54
[7]	Pulse input 29
[8]	Pulse input 33
[20]	Digital pot.meter
[21]	Analog input X30/11
[22]	Analog input X30/12
[23]	Analog Input X42/1
[24]	Analog Input X42/3
[25]	Analog Input X42/5
[29]	Analog Input X48/2
[30]	Ext. Closed-loop 1
[31]	Ext. Closed-loop 2
[32]	Ext. Closed-loop 3

21-34 Ext. 2 Feedback Source		
Option:	Function:	
		See 21-14 Ext. 1 Feedback Source for details.
[0]	No function	
[1]	Analog Input 53	
[2]	Analog Input 54	
[3]	Pulse input 29	
[4]	Pulse input 33	
[7]	Analog input X30/11	
[8]	Analog input X30/12	
[9]	Analog Input X42/1	
[10]	Analog Input X42/3	
[11]	Analog Input X42/5	
[15]	Analog Input X48/2	
[100]	Bus feedback 1	
[101]	Bus feedback 2	
[102]	Bus feedback 3	

21-35 Ext. 2 Setpoint		
Range:	Function:	
0 ExtPID2Unit*	[par. 21-31 - par. 21-32 ExtPID2Unit]	See 21-15 Ext. 1 Setpoint for details.

21-37 Ext. 2 Reference [Unit]		
Range:	Function:	
0 ExtPID2Unit*	[-999999.999 - 999999.999 ExtPID2Unit]	See 21-17 Ext. 1 Reference [Unit], Ext. 1 Reference [Unit], for details.

21-38 Ext. 2 Feedback [Unit]		
Range:	Function:	
0 ExtPID2Unit*	[-999999.999 - 999999.999 ExtPID2Unit]	See 21-18 Ext. 1 Feedback [Unit] for details.

21-39 Ext. 2 Output [%]		
Range:	Function:	
0 %*	[0 - 100 %]	See 21-19 Ext. 1 Output [%] for details.

3.18.5 21-4* Closed-loop 2 PID

21-40 Ext. 2 Normal/Inverse Control		
Option:	Function:	
		See 21-20 Ext. 1 Normal/Inverse Control for details.
[0]	Normal	
[1]	Inverse	

21-41 Ext. 2 Proportional Gain		
Range:	Function:	
0.01 *	[0 - 10]	See 21-21 Ext. 1 Proportional Gain for details.
0.50 *	[0 - 10]	

21-42 Ext. 2 Integral Time		
Range:	Function:	
10000 s*	[0.01 - 10000 s]	See 21-22 Ext. 1 Integral Time for details.
20 s*	[0.01 - 10000 s]	

21-43 Ext. 2 Differentiation Time		
Range:	Function:	
0 s*	[0 - 10 s]	See 21-23 Ext. 1 Differentiation Time for details.

21-44 Ext. 2 Dif. Gain Limit		
Range:	Function:	
5 *	[1 - 50]	See 21-24 Ext. 1 Dif. Gain Limit for details.

3.18.6 21-5* Closed-loop 3 Ref/Fb

21-50 Ext. 3 Ref./Feedback Unit		
Option:	Function:	
		See 21-10 Ext. 1 Ref./Feedback Unit for details.
[0]	None	
[1]	%	
[5]	PPM	
[10]	min	
[11]	RPM	
[12]	PULSE/s	
[20]	liter / sec.	
[21]	liter / min	
[22]	liter / hr.	
[23]	m ³ / sec.	
[24]	m ³ /min	
[25]	m ³ / hr.	
[30]	kg / sec.	
[31]	kg/min	
[32]	kg / hr.	
[33]	ton / min	
[34]	ton / hr.	
[40]	m / sec.	
[41]	m/min	
[45]	m	
[60]	°C	
[70]	mbar	
[71]	bar	
[72]	Pa	
[73]	kPa	
[74]	m WG	

21-50 Ext. 3 Ref./Feedback Unit		
Option:	Function:	
[75]	mm Hg	
[80]	kW	
[120]	GPM	
[121]	gal / sec.	
[122]	gal/min	
[123]	gal / hr.	
[124]	CFM	
[125]	ft ³ /s	
[126]	ft ³ /min	
[127]	ft ³ /h	
[130]	lbs / sec.	
[131]	lbs / min.	
[132]	lbs / hr.	
[140]	ft/s	
[141]	ft/min	
[145]	ft	
[160]	°F	
[170]	psi	
[171]	lb/in ²	
[172]	in. wtr. gage	
[173]	ft WG	
[174]	in Hg	
[180]	HP	

21-51 Ext. 3 Minimum Reference		
Range:	Function:	
0 ExtPID3Unit*	[-999999.999 - par. 21-52 ExtPID3Unit]	See 21-11 Ext. 1 Minimum Reference for details.

21-52 Ext. 3 Maximum Reference		
Range:	Function:	
100 ExtPID3Unit*	[par. 21-51 - 999999.999 ExtPID3Unit]	See 21-12 Ext. 1 Maximum Reference for details.

21-53 Ext. 3 Reference Source		
Option:	Function:	
		See 21-13 Ext. 1 Reference Source for details.
[0]	No function	
[1]	Analog Input 53	
[2]	Analog Input 54	
[7]	Pulse input 29	
[8]	Pulse input 33	
[20]	Digital pot.meter	
[21]	Analog input X30/11	
[22]	Analog input X30/12	
[23]	Analog Input X42/1	

21-53 Ext. 3 Reference Source		
Option:	Function:	
[24]	Analog Input X42/3	
[25]	Analog Input X42/5	
[29]	Analog Input X48/2	
[30]	Ext. Closed-loop 1	
[31]	Ext. Closed-loop 2	
[32]	Ext. Closed-loop 3	

21-54 Ext. 3 Feedback Source		
Option:	Function:	
		See 21-14 Ext. 1 Feedback Source for details.
[0]	No function	
[1]	Analog Input 53	
[2]	Analog Input 54	
[3]	Pulse input 29	
[4]	Pulse input 33	
[7]	Analog input X30/11	
[8]	Analog input X30/12	
[9]	Analog Input X42/1	
[10]	Analog Input X42/3	
[11]	Analog Input X42/5	
[15]	Analog Input X48/2	
[100]	Bus feedback 1	
[101]	Bus feedback 2	
[102]	Bus feedback 3	

21-55 Ext. 3 Setpoint		
Range:	Function:	
0 ExtPID3Unit*	[par. 21-51 - par. 21-52 ExtPID3Unit]	See 21-15 Ext. 1 Setpoint for details.

21-57 Ext. 3 Reference [Unit]		
Range:	Function:	
0 ExtPID3Unit*	[-999999.999 - 999999.999 ExtPID3Unit]	See 21-17 Ext. 1 Reference [Unit] for details.

21-58 Ext. 3 Feedback [Unit]		
Range:	Function:	
0 ExtPID3Unit*	[-999999.999 - 999999.999 ExtPID3Unit]	See 21-18 Ext. 1 Feedback [Unit] for details.

21-59 Ext. 3 Output [%]		
Range:	Function:	
0 %*	[0 - 100 %]	

3.18.7 21-6* Closed-loop 3 PID

21-60 Ext. 3 Normal/Inverse Control		
Option:	Function:	
		See 21-20 Ext. 1 Normal/Inverse Control for details.
[0]	Normal	
[1]	Inverse	

21-61 Ext. 3 Proportional Gain		
Range:	Function:	
0.01 *	[0 - 10]	See 21-21 Ext. 1 Proportional Gain for details.
0.50 *	[0 - 10]	

21-62 Ext. 3 Integral Time		
Range:	Function:	
10000 s*	[0.01 - 10000 s]	See 21-22 Ext. 1 Integral Time for details.
20 s*	[0.01 - 10000 s]	

21-63 Ext. 3 Differentiation Time		
Range:	Function:	
0 s*	[0 - 10 s]	See 21-23 Ext. 1 Differentiation Time for details.

21-64 Ext. 3 Dif. Gain Limit		
Range:	Function:	
5 *	[1 - 50]	See 21-24 Ext. 1 Dif. Gain Limit for details.

3.19 Parameters 22-** Application Functions

3.19.1 22-0* Miscellaneous

This group contains parameters used for monitoring water/waste water applications.

22-00 External Interlock Delay		
Range:	Function:	
0 s* s]	[0 - 600	Only relevant if one of the digital inputs in parameter group 5-1* has been programmed for [7] External Interlock. The external interlock timer

22-00 External Interlock Delay		
Range:	Function:	
		will introduce a delay after the signal has been removed from the digital input programmed for External Interlock, before a reaction takes place.

3.19.2 22-2* No-Flow Detection

130BA252.14

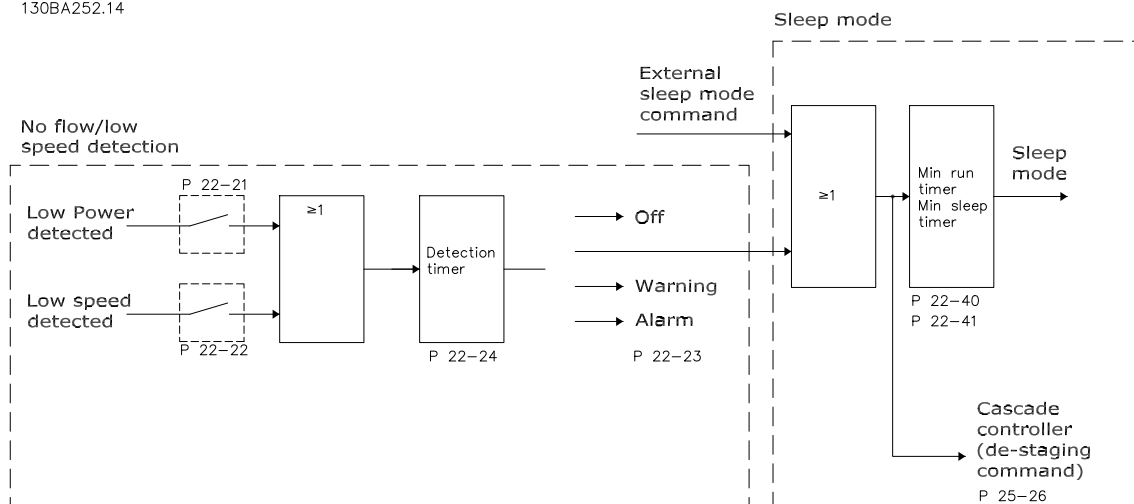

Figure 3.48 Signal Flow Chart

The VLT AQUA Drive includes functions for detecting if the load conditions in the system allow the motor to be stopped:

- *Low Power Detection
- *Low Speed Detection

One of these two signals must be active for a set time (22-24 No-Flow Delay) before selected action takes place. Possible actions to select (22-23 No-Flow Function): No action, Warning, Alarm, Sleep Mode.

No-Flow Detection

This function is used for detecting a no-flow situation in pump systems where all valves can be closed. Can be used both when controlled by the integrated PI controller in VLT AQUA Drive or an external PI controller. The actual configuration must be programmed in 1-00 Configuration Mode.

Configuration mode for

- Integrated PI Controller: Closed-loop
- External PI Controller: Open-loop

CAUTION

Carry out No-Flow tuning before setting the PI controller parameters!

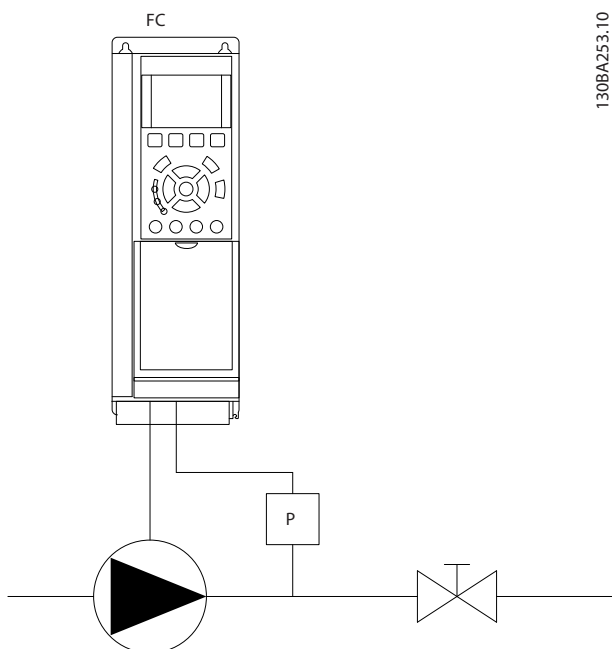

Figure 3.49

130BA253.10

systems with fluctuating suction pressure, or if the pump has a flat characteristic towards low speed.

The two sets of data must be based on measurement of power at approximately 50% and 85% of maximum speed with the valve(s) closed. The data are programmed in the parameter group 22-3*. It is also possible to run a 22-20 *Low Power Auto Set-up*, automatically stepping through the commissioning process and also automatically storing the data measured. The adjustable frequency drive must be set for Open-loop in 1-00 *Configuration Mode*, when carrying out the Auto Set-up (See parameter group 22-3*, *No-Flow Power Tuning*).

CAUTION

If using the integrated PI controller, carry out No-Flow tuning before setting the PI controller parameters!

Low speed detection

Low Speed Detection gives a signal if the motor is operating with minimum speed as set in 4-11 *Motor Speed Low Limit [RPM]* or 4-12 *Motor Speed Low Limit [Hz]*. Actions are common with No-Flow Detection (individual selection not possible).

The use of Low Speed Detection is not limited to systems with a no-flow situation, but can be used in any system where operation at minimum speed allows for a stop of the motor until the load calls for a speed higher than minimum speed, e.g., systems with fans and compressors.

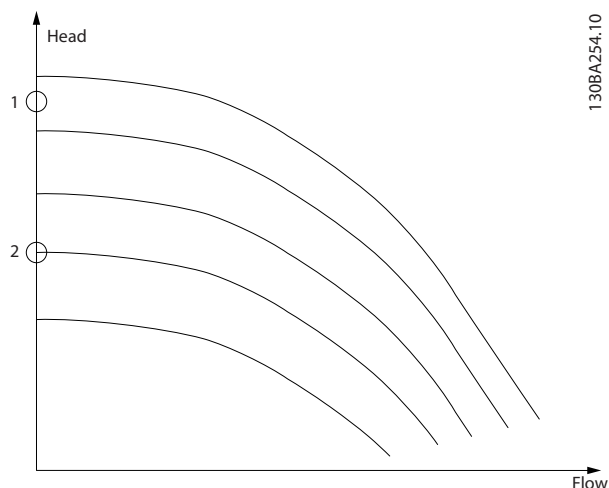

Figure 3.50

130BA254.10

NOTICE!

In pump systems, ensure that the minimum speed in 4-11 *Motor Speed Low Limit [RPM]* or 4-12 *Motor Speed Low Limit [Hz]* has been set high enough for detection as the pump can run with a rather high speed even with valves closed.

Dry pump detection

No-Flow Detection can also be used for detecting if the pump has run dry (low power consumption-high speed). Can be used with both the integrated PI controller and an external PI controller.

The condition for Dry Pump signal:

- Power consumption below no-flow level
- and
- Pump running at maximum speed or maximum reference open-loop, whichever is lowest.

The signal must be active for a set time (22-27 *Dry Pump Delay*) before selected action takes place.

Possible Actions to select (22-26 *Dry Pump Function*):

No-Flow Detection is based on the measurement of speed and power. For a certain speed, the adjustable frequency drive calculates the power at no-flow.

This coherence is based on the adjustment of two sets of speed and associated power at no-flow. By monitoring the power, it is possible to detect no-flow conditions in

- Warning
- Alarm

No-Flow Detection must be enabled (22-23 *No-Flow Function*) and commissioned (parameter group 22-3*, *No-Flow Power Tuning*).

22-20 Low Power Auto Set-up		
Start of auto set-up of power data for No-Flow Power tuning.		
Option:	Function:	
[0]	OFF	
[1]	Enabled	When set for <i>Enabled</i> , an auto set-up sequence is activated, automatically setting speed to approx. 50% and 85% of rated motor speed (4-13 <i>Motor Speed High Limit [RPM]</i> , 4-14 <i>Motor Speed High Limit [Hz]</i>). At those two speeds, the power consumption is automatically measured and stored. Before enabling Auto Set-up: <ol style="list-style-type: none"> 1. Close valve(s) in order to create a no-flow condition 2. The adjustable frequency drive must be set for open-loop (1-00 <i>Configuration Mode</i>). Note that it is important also to set 1-03 <i>Torque Characteristics</i> .

NOTICE!

Auto set-up must be done when the system has reached normal operating temperature!

NOTICE!

It is important that the 4-13 *Motor Speed High Limit [RPM]* or 4-14 *Motor Speed High Limit [Hz]* is set to the max. operational speed of the motor!

It is important to do the auto set-up before configuring the integrated PI controller as settings will be reset when changing from Closed to Open-loop in 1-00 *Configuration Mode*.

NOTICE!

Carry out the tuning with the same settings in 1-03 *Torque Characteristics*, as for operation after the tuning.

22-21 Low Power Detection		
Option:	Function:	
[0]	Disabled	
[1]	Enabled	If selecting Enabled, the Low Power Detection commissioning must be carried out in order to set the parameters in parameter group 22-3* <i>No-Flow Power Tuning</i> for proper operation!

22-22 Low Speed Detection		
Option:	Function:	
[0]	Disabled	
[1]	Enabled	Select Enabled for detecting when the motor operates with a speed as set in 4-11 <i>Motor Speed Low Limit [RPM]</i> or 4-12 <i>Motor Speed Low Limit [Hz]</i> .

22-23 No-Flow Function		
Common actions for Low Power Detection and Low Speed Detection (Individual selections not possible).		
Option:	Function:	
[0]	OFF	
[1]	Sleep Mode	The adjustable frequency drive will enter Sleep Mode and stop when a No-Flow condition is detected. See parameter group 22-4* <i>Sleep mode</i> for programming options for Sleep mode.
[2]	Warning	The adjustable frequency drive will continue to run, but activate a No-Flow Warning [W92]. A drive digital output or a serial communication bus can communicate a warning to other equipment.
[3]	Alarm	The adjustable frequency drive will stop running and activate a No-Flow Alarm [A 92]. An adjustable frequency drive digital output or a serial communication bus can communicate an alarm to other equipment.

NOTICE!

Do not set 14-20 *Reset Mode* to [13] Infinite auto reset when 22-23 *No-Flow Function* is set to [3] Alarm. Doing so will cause the adjustable frequency drive to continuously cycle between running and stopping when a No-Flow condition is detected.

NOTICE!

If the adjustable frequency drive is equipped with a constant speed bypass with an automatic bypass function that starts the bypass if the adjustable frequency drive experiences a persistent alarm condition, be sure to disable the bypass's automatic bypass function, if [3] Alarm is selected as the No-Flow Function.

22-24 No-Flow Delay		
Range:	Function:	
10 s*	[1 - 600 s]	Set the time. Low Power/Low Speed must remain detected to activate signal for actions. If detection disappears before the timer runs out, the timer will be reset.

22-26 Dry Pump Function		
Select desired action for dry pump operation.		
Option:	Function:	
[0]	OFF	
[1]	Warning	The adjustable frequency drive will continue to run but activate a Dry Pump warning [W93]. An adjustable frequency drive digital output or a serial communication bus can communicate a warning to other equipment.
[2]	Alarm	The adjustable frequency drive will stop running and activate a Dry Pump alarm [A93]. An adjustable frequency drive digital output or a serial communication bus can communicate an alarm to other equipment.
[3]	Man. Reset Alarm	The adjustable frequency drive will stop running and activate a Dry Pump alarm [A93]. An adjustable frequency drive digital output or a serial communication bus can communicate an alarm to other equipment.

NOTICE!

Low Power Detection must be Enabled (22-21 Low Power Detection) and commissioned (using either parameter group 22-3*, No-Flow Power Tuning, or 22-20 Low Power Auto Set-up) in order to use Dry Pump Detection.

NOTICE!

Do not set 14-20 Reset Mode, to [13] Infinite auto reset, when 22-26 Dry Pump Function is set to [2] Alarm. Doing so will cause the adjustable frequency drive to continuously cycle between running and stopping when a dry pump condition is detected.

NOTICE!

If the adjustable frequency drive is equipped with a constant speed bypass with an automatic bypass function that starts the bypass if the adjustable frequency drive experiences a persistent alarm condition, be sure to disable the bypass's automatic bypass function, if [2] Alarm or [3] Man. Reset Alarm is selected as the Dry Pump Function.

22-27 Dry Pump Delay		
Range:	Function:	
10 s*	[0 - 600 s]	Defines for how long the Dry Pump condition must be active before activating Warning or Alarm

22-28 No-Flow Low Speed [RPM]		
Range:	Function:	
Size related*	[par. 4-11 - par. 4-13 RPM]	Used to set the speed for no-flow low speed detection. If a low speed detection at a speed different from the motor minimum speed is needed, this parameter may be used.

22-29 No-Flow Low Speed [Hz]		
Range:	Function:	
Size related*	[par. 4-12 - par. 4-14 Hz]	Used to set the speed for no-flow low speed detection. If a low speed detection at a speed different from the motor minimum speed is needed, this parameter may be used.

3.19.3 22-3* No-Flow Power Tuning

Tuning Sequence, if not choosing *Auto Set-up* in 22-20 *Low Power Auto Set-up*:

1. Close the main valve to stop flow.
2. Run with motor until the system has reached normal operating temperature.
3. Press [Hand On] and adjust speed for approx. 85% of rated speed. Note the exact speed.
4. Read power consumption either by looking for actual power in the data line in the LCP or call 16-10 *Power [kW]* or 16-11 *Power [hp]* in the Main Menu. Note the power readout.
5. Change the speed to approx. 50% of rated speed. Note the exact speed.
6. Read power consumption either by looking for actual power in the data line in the LCP or call 16-10 *Power [kW]* or 16-11 *Power [hp]* in the Main Menu. Note the power readout.
7. Program the speeds used in 22-32 *Low Speed [RPM]*, 22-33 *Low Speed [Hz]*, 22-36 *High Speed [RPM]* and 22-37 *High Speed [Hz]*.
8. Program the associated power values in 22-34 *Low Speed Power [kW]*, 22-35 *Low Speed Power [HP]*, 22-38 *High Speed Power [kW]* and 22-39 *High Speed Power [HP]*.
9. Switch back by means of [Auto On] or [Off].

NOTICE!

Set 1-03 *Torque Characteristics* before tuning takes place.

22-30 No-Flow Power		
Range:		Function:
0 kW*	[0 - 0 kW]	Readout of calculated no-flow power at actual speed. If power drops to the display value, the adjustable frequency drive will consider the condition as a no-flow situation.

22-31 Power Correction Factor		
Range:		Function:
100 %*	[1 - 400 %]	Make corrections to the calculated power at 22-30 <i>No-Flow Power</i> . If No Flow is detected when it should not be detected, the setting should be decreased. However, if No Flow is not detected when it should be detected, the setting should be increased to above 100%.

22-32 Low Speed [RPM]		
Range:		Function:
Size related*	[0 - par. 22-36 RPM]	To be used if 0-02 <i>Motor Speed Unit</i> has been set for RPM (parameter not visible if Hz selected). Set used speed to the 50% level. This function is used for storing values needed to tune No-Flow Detection.

22-33 Low Speed [Hz]		
Range:		Function:
Size related*	[0 - par. 22-37 Hz]	To be used if 0-02 <i>Motor Speed Unit</i> has been set for Hz (parameter not visible if RPM selected). Set used speed to the 50% level. The function is used for storing values needed to tune No-Flow Detection.

22-34 Low Speed Power [kW]		
Range:		Function:
Size related*	[0 - 0.00 kW]	To be used if 0-03 <i>Regional Settings</i> has been set for International (parameter not visible if North America selected). Set power consumption to 50% speed level. This function is used for storing values needed to tune No-Flow Detection.

22-35 Low Speed Power [HP]		
Range:		Function:
Size related*	[0 - 0.00 hp]	To be used if 0-03 <i>Regional Settings</i> has been set for North America (parameter not visible if International selected). Set power consumption to 50% speed level.

22-35 Low Speed Power [HP]		
Range:		Function:
		This function is used for storing values needed to tune No-Flow Detection.

22-36 High Speed [RPM]		
Range:		Function:
Size related*	[0 - par. 4-13 RPM]	To be used if 0-02 <i>Motor Speed Unit</i> has been set for RPM (parameter not visible if Hz selected). Set used speed for the 85% level. The function is used for storing values needed to tune No-Flow Detection.

22-37 High Speed [Hz]		
Range:		Function:
Size related*	[0 - par. 4-14 Hz]	To be used if 0-02 <i>Motor Speed Unit</i> has been set for Hz (parameter not visible if RPM selected). Set used speed for the 85% level. The function is used for storing values needed to tune No-Flow Detection.

22-38 High Speed Power [kW]		
Range:		Function:
Size related*	[0 - 0.00 kW]	To be used if 0-03 <i>Regional Settings</i> has been set for International (parameter not visible if North America selected). Set power consumption to 85% speed level. This function is used for storing values needed to tune No-Flow Detection.

22-39 High Speed Power [HP]		
Range:		Function:
Size related*	[0 - 0.00 hp]	To be used if 0-03 <i>Regional Settings</i> has been set for North America (parameter not visible if International selected). Set power consumption to 85% speed level. This function is used for storing values needed to tune No-Flow Detection.

3.19.4 22-4* Sleep Mode

If the load on the system allows for stop of the motor and the load is monitored, the motor can be stopped by activating the Sleep Mode function. This is not a normal Stop command, but ramps the motor down to 0 RPM and stops energizing the motor. When in Sleep mode, certain conditions are monitored to find out when a load has been applied to the system again.

Sleep mode can be activated either from the No-Flow Detection/Minimum Speed Detection or via an external signal applied to one of the digital inputs (must be programmed via the parameters for configuration of the digital inputs, parameter group 5-1*).

To make it possible to use, for example, an electro-mechanical flow switch to detect a no flow condition and activate Sleep mode, the action takes place at raising edge of the external signal applied (otherwise, the adjustable frequency drive would never come out of Sleep mode as the signal would be steady connected).

If 25-26 *Destage At No-Flow* is set for Enabled, activating Sleep mode will apply a command to the cascade controller (if enabled) to start de-staging of lag pumps (fixed speed) before stopping the lead pump (variable speed).

When entering Sleep mode, the lower status line in the Local Control Panel shows Sleep mode.

See also signal flow chart, Figure 3.48.

There are three different ways of using the Sleep mode function:

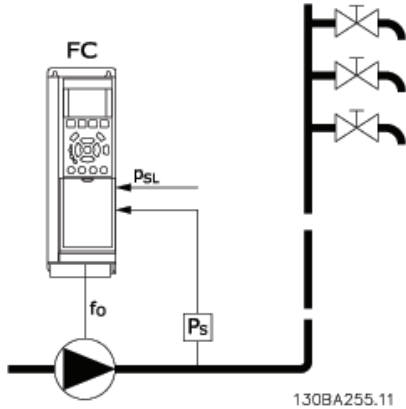

Figure 3.51 Legend: FC=adjustable frequency drive; fo=frequency out; Ps=P system; PsL=P setpoint

1) Systems where the integrated PI controller is used for controlling pressure or temperature, e.g., boost systems with a pressure feedback signal applied to the adjustable frequency drive from a pressure transducer. 1-00 *Configuration Mode* must be set for Closed-loop and the PI controller configured for desired reference and feedback signals.

Example: Boost system.

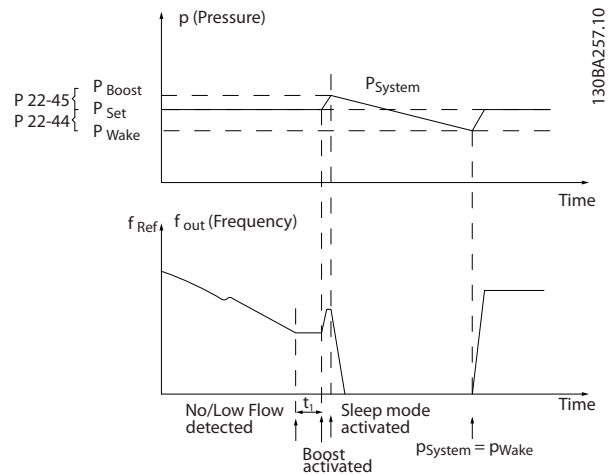

Figure 3.52

If no-flow is detected, the adjustable frequency drive will increase the setpoint for pressure to ensure a slight overpressure in the system (boost to be set in 22-45 *Setpoint Boost*).

The feedback from the pressure transducer is monitored and when this pressure has dropped with a set percentage below the normal setpoint for pressure (Pset), the motor will ramp up again and pressure will be controlled for reaching the set value (Pset).

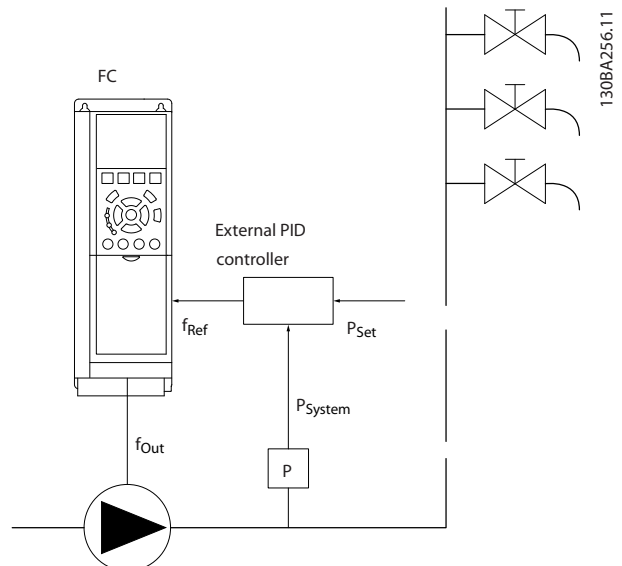

Figure 3.53

2) In systems where the pressure or temperature is controlled by an external PI controller, the wake-up conditions cannot be based on feedback from the pressure/temperature transducer as the setpoint is not known. In the example with a boost system, desired pressure P_{Set} is not known. 1-00 Configuration Mode, must be set for Open-loop. Example: Boost system.

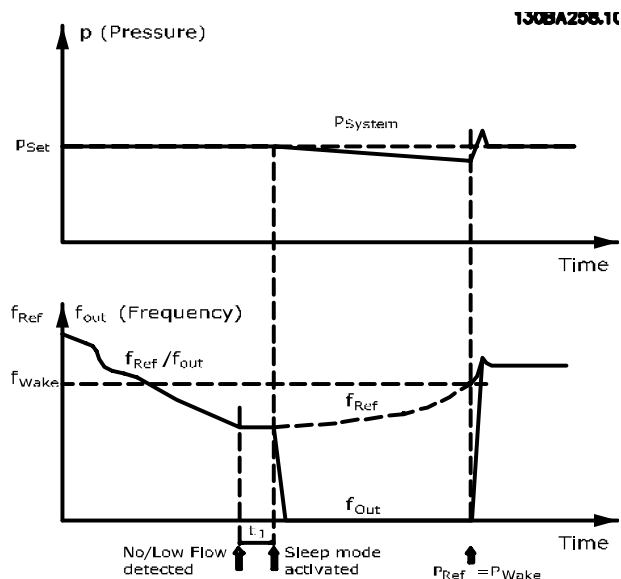

Figure 3.54

When low power or low speed is detected the motor is stopped, but the reference signal (f_{ref}) from the external controller is still monitored and because of the low pressure created, the controller will increase the reference signal to gain pressure. When the reference signal has reached a set value f_{wake} , the motor restarts.

The speed is set manually by an external reference signal (Remote Reference). The settings (parameter group 22-3*) for tuning of the No-Flow function must be set to default.

	Internal PI Controller (1-00 Configuration Mode)		External PI controller or manual control (1-00 Configuration Mode)	
	Sleep mode	Wake up	Sleep mode	Wake up
No-Flow detection (pumps only)	Yes		Yes (except manual setting of speed)	
Low speed detection	Yes		Yes	
External signal	Yes		Yes	
Pressure/Temperature (transmitter connected)		Yes		No
Output frequency		No		Yes

Table 3.26 Configuration Possibilities, Overview

NOTICE!

Sleep mode will not be active when Local Reference is active (set speed manually using the arrow keys on the LCP). See 3-13 Reference Site.

Does not work in Hand-mode. Auto set-up in open-loop must be carried out before setting input/output in closed-loop.

22-40 Minimum Run Time		
Range:	Function:	
10 s*	[0 - 600 s]	Set the desired minimum running time for the motor after a start command (digital input or bus) before entering sleep mode.

22-41 Minimum Sleep Time		
Range:	Function:	
10 s*	[0 - 600 s]	Set the desired minimum time for staying in sleep mode. This will override any wake-up conditions.
30 s*	[0 - 600 s]	

22-42 Wake-up Speed [RPM]		
Range:	Function:	
Size related*	[par. 4-11 - par. 4-13 RPM]	To be used if 0-02 Motor Speed Unit has been set for RPM (parameter not visible if Hz selected). Only to be used if 1-00 Configuration Mode is set for open-loop and speed reference is applied by an external controller. Set the reference speed at which sleep mode should be canceled.

22-43 Wake-up Speed [Hz]		
Range:	Function:	
Size related*	[par. 4-12 - par. 4-14 Hz]	To be used if 0-02 Motor Speed Unit has been set for Hz (parameter not visible if RPM selected). Only to be used if 1-00 Configuration Mode is set for open-loop and speed reference is applied by an external controller controlling the pressure. Set the reference speed at which the Sleep mode should be cancelled.

22-44 Wake-up Ref./FB Difference		
Range:	Function:	
10 %*	[0 - 100 %]	

22-45 Setpoint Boost		
Range:	Function:	
0 %*	[-100 - 100 %]	

22-46 Maximum Boost Time		
Range:	Function:	
60 s*	[0 - 600 s]	Only to be used if 1-00 Configuration Mode is set for closed-loop and the integrated PI controller is used for controlling the pressure. Set the maximum time for which boost mode will be allowed. If the set time is exceeded,

22-46 Maximum Boost Time		
Range:	Function:	
		sleep mode will be entered and will not wait for the set boost pressure to be reached.

3.19.5 22-5* End of Curve

The End of Curve conditions occur when a pump is yielding a too large volume to ensure the set pressure. This can occur if there is a leakage in the distribution pipe system after the pump causing the pump to operate at the end of the pump characteristic, valid for the max. speed set in 4-13 Motor Speed High Limit [RPM] or 4-14 Motor Speed High Limit [Hz].

If the feedback is 2.5% of the programmed value in 3-03 Maximum Reference below the setpoint for the desired pressure for a set time (22-51 End of Curve Delay), and the pump is running with max. speed set in 4-13 Motor Speed High Limit [RPM] or 4-14 Motor Speed High Limit [Hz], the function selected in 22-50 End of Curve Function will take place.

It is possible to get a signal on one of the digital outputs by selecting End of Curve [192] in parameter group 5-3* Digital Outputs and/or parameter group 5-4* Relays. The signal will be present when an End of Curve condition occurs and the selection in 22-50 End of Curve Function is different from Off. The end of curve function can only be used when operating with the built-in PID controller (closed-loop in 1-00 Configuration Mode).

22-50 End of Curve Function		
Option:	Function:	
[0]	OFF	End of Curve monitoring not active.
[1]	Warning	The adjustable frequency drive will continue to run, but activate a End of Curve warning [W94]. An adjustable frequency drive digital output or a serial communication bus can communicate a warning to other equipment.
[2]	Alarm	The adjustable frequency drive will stop running and activate a End of Curve alarm [A 94]. An adjustable frequency drive digital output or a serial communication bus can communicate an alarm to other equipment.
[3]	Man. Reset Alarm	The adjustable frequency drive will stop running and activate a End of Curve alarm [A 94]. An adjustable frequency drive digital output or a serial communication bus can communicate an alarm to other equipment.

NOTICE!

Automatic restart will reset the alarm and start the system again.

NOTICE!

Do not set 14-20 *Reset Mode*, to [13] *Infinite auto reset*, when 22-50 *End of Curve Function* is set to [2] *Alarm*. Doing so will cause the adjustable frequency drive to continuously cycle between running and stopping when a End of Curve condition is detected.

NOTICE!

If the adjustable frequency drive is equipped with a constant speed bypass with an automatic bypass function that starts the bypass if the adjustable frequency drive experiences a persistent alarm condition, be sure to disable the bypass's automatic bypass function, if [2] *Alarm* or [3] *Man. Reset Alarm* is selected as the End of Curve Function.

22-51 End of Curve Delay		
Range:	Function:	
10 s* [0 - 600 s]	When an end of curve condition is detected, a timer is activated. When the time set in this parameter expires, and the End of Curve condition has been steady in the entire period, the function set in 22-50 <i>End of Curve Function</i> will be activated. If the condition disappears before the timer expires, the timer will be reset.	

3.19.6 22-6* Broken Belt Detection

The broken belt detection can be used in both closed-loop and open-loop systems for pumps and fans. If the estimated motor torque is below the broken belt torque value (22-61 *Broken Belt Torque*) and the adjustable frequency drive output frequency is above or equal to 15 Hz, the broken belt function (22-60 *Broken Belt Function*) is performed.

22-60 Broken Belt Function		
Selects the action to be performed if the Broken Belt condition is detected		
Option:	Function:	
[0]	OFF	
[1]	Warning	The adjustable frequency drive will continue to run, but will activate a Broken Belt Warning [W95]. An adjustable frequency drive digital output or a serial communication bus can communicate a warning to other equipment.
[2]	Trip	The adjustable frequency drive will stop running and activate a Broken Belt alarm [A 95]. An adjustable frequency drive digital output or a serial

22-60 Broken Belt Function		
Selects the action to be performed if the Broken Belt condition is detected		
Option:	Function:	
		communication bus can communicate an alarm to other equipment.

NOTICE!

Do not set 14-20 *Reset Mode*, to [13] *Infinite auto reset*, when 22-60 *Broken Belt Function* is set to [2] *Trip*. Doing so will cause the adjustable frequency drive to continuously cycle between running and stopping when a broken belt condition is detected.

NOTICE!

If the adjustable frequency drive is equipped with a constant speed bypass with an automatic bypass function that starts the bypass if the adjustable frequency drive experiences a persistent alarm condition, be sure to disable the bypass's automatic bypass function, if [2] *Trip* is selected as the Broken Belt Function.

22-61 Broken Belt Torque		
Range:	Function:	
10 %* [0 - 100 %]	Sets the broken belt torque as a percentage of the rated motor torque.	

22-62 Broken Belt Delay		
Range:	Function:	
10 s [0 - 600 s]	Sets the time for which the broken belt conditions must be active before carrying out the action selected in 22-60 <i>Broken Belt Function</i> .	

3.19.7 22-7* Short Cycle Protection

In some applications, there is often a need for limiting the numbers of starts. One way to do this is to ensure a minimum run time (time between a start and a stop) and a minimum interval between starts.

This means that any normal stop command can be overridden by 22-77 *Minimum Run Time* and any normal start command (Start/Jog/Freeze) can be overridden by 22-76 *Interval between Starts*.

None of the two functions are active if *Hand On* or *Off* modes have been activated via the LCP. If selecting *Hand On* or *Off*, the two timers will be reset to 0, and not start counting until [Auto On] is pressed and an active start command applied.

22-75 Short Cycle Protection		
Option:	Function:	
[0]	Disabled	Timer set in 22-76 Interval between Starts is disabled.
[1]	Enabled	Timer set in 22-76 Interval between Starts is enabled.

22-76 Interval between Starts		
Range:	Function:	
Size related*	[par. 22-77 - 3600 s]	Sets the time desired as minimum time between two starts. Any normal start command (Start/Jog/ Freeze) will be disregarded until the timer has expired.

22-77 Minimum Run Time		
Range:	Function:	
0 s*	[0 - par. 22-76 s]	Sets the time desired as minimum run time after a normal start command (Start/Jog/ Freeze). Any normal stop command will be disregarded until the set time has expired. The timer will start counting following a normal start command (Start/Jog/Freeze). The timer will be overridden by a Coast (Inverse) or an External Interlock command.

NOTICE!

Does not work in cascade mode.

22-78 Minimum Run Time Override		
Option:	Function:	
[0]	Disabled	
[1]	Enabled	

22-79 Minimum Run Time Override Value		
Range:	Function:	
0 ProcessCtrlUnit*	[-999999.999 - 999999.999 ProcessCtrlUnit]	

3.19.8 22-8* Flow Compensation

Sometimes it is not possible for a pressure transducer to be placed at a remote point in the system and it can only be located close to the fan/pump outlet. Flow compensation operates by adjusting the setpoint according to the output frequency, which is almost proportional to flow, thus compensating for higher losses at higher flow rates.

H_{DESIGN} (Required pressure) is the setpoint for closed-loop (PI) operation of the adjustable frequency drive and is set as for closed-loop operation without flow compensation.

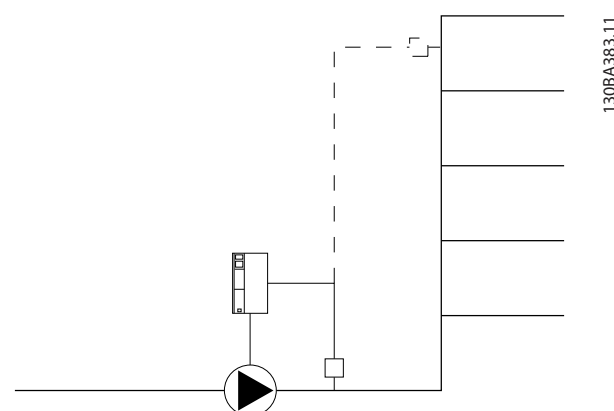

Figure 3.55

There are two methods which can be employed, depending upon whether or not the Speed at System design Working Point is known.

Parameter used	Speed at Design Point KNOWN	Speed at Design Point UNKNOWN
22-80 Flow Compensation	+	+
22-81 Square-linear Curve Approximation	+	+
22-82 Work Point Calculation	+	+
22-83 Speed at No-Flow [RPM]/22-84 Speed at No-Flow [Hz]	+	+
22-85 Speed at Design Point [RPM]/22-86 Speed at Design Point [Hz]	+	-
22-87 Pressure at No-Flow Speed	+	+
22-88 Pressure at Rated Speed	-	+
22-89 Flow at Design Point	-	+
22-90 Flow at Rated Speed	-	+

Table 3.27 Speed at Design Point Known/Unknown

22-80 Flow Compensation		
Option:	Function:	
[0] Disabled	Setpoint compensation not active.	
[1] Enabled	Setpoint compensation is active. Enabling this parameter allows the Flow Compensated Setpoint operation.	

22-81 Square-linear Curve Approximation		
Range:	Function:	
100 %*	[0 - 100 %]	

NOTICE!

Not visible when running in cascade.

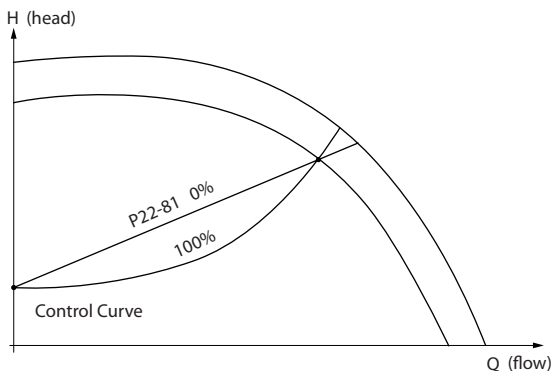

Figure 3.56

22-82 Work Point Calculation

Option:	Function:
---------	-----------

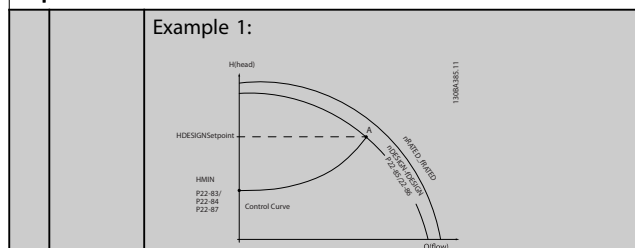

Figure 3.57 Speed at System Design Working Point is Known

From the data sheet showing characteristics for the specific equipment at different speeds, simply reading across from the H_{DESIGN} point and the Q_{DESIGN} point allows us to find point A, which is the System Design Working Point. The pump characteristics at this point should be identified and the associated speed programmed. Closing the valves and adjusting the speed until H_{MIN} has been achieved allows the speed at the no-flow point to be identified.

Adjustment of 22-81 Square-linear Curve Approximation then allows the shape of the control curve to be adjusted infinitely.

Example 2:

Speed at System Design Working Point is not known: Where the Speed at System Design Working Point is unknown, another reference point on the control curve needs to be determined by means of the data sheet. By looking at the curve for the rated speed and plotting the design pressure (H_{DESIGN} , Point C) the flow at that pressure Q_{RATED} can be determined. Similarly, by plotting the design flow (Q_{DESIGN} , Point D). The pressure H_{DESIGN} at that flow can be determined. Knowing these two points on the pump curve, along with H_{MIN} described above, allows the adjustable frequency

22-82 Work Point Calculation		
Option:	Function:	
	drive to calculate the reference point B and thus to plot the control curve that will also include the system design working point A.	
	<p>Figure 3.58</p>	
[0]	Disabled	Work Point Calculation not active. To be used if speed at design point is known (see Table 3.27).
[1]	Enabled	Work Point Calculation is active. Enabling this parameter allows the calculation of the unknown System Design Working Point at 50/60 Hz speed, from the input data set in 22-83 Speed at No-Flow [RPM] 22-84 Speed at No-Flow [Hz], 22-87 Pressure at No-Flow Speed, 22-88 Pressure at Rated Speed, 22-89 Flow at Design Point and 22-90 Flow at Rated Speed.

22-83 Speed at No-Flow [RPM]		
Range:	Function:	
Size related*	[0 - par. 22-85 RPM]	Resolution 1 RPM. The speed of the motor at which the flow is zero and the minimum pressure H_{MIN} is achieved should be entered here in RPM. Alternatively, the speed in Hz can be entered in 22-84 Speed at No-Flow [Hz]. If it has been decided to use RPM in 0-02 Motor Speed Unit, then 22-85 Speed at Design Point [RPM] should also be used. Closing the valves and reducing the speed until minimum pressure H_{MIN} is achieved will determine this value.

22-84 Speed at No-Flow [Hz]		
Range:	Function:	
Size related*	[0 - par. 22-86 Hz]	Resolution 0.033 Hz. The speed of the motor at which flow has effectively stopped and minimum pressure H_{MIN} is achieved should be entered here in Hz. Alternatively, the speed in RPM can be entered in 22-83 Speed at No-Flow [RPM]. If it has been decided to use Hz in 0-02 Motor Speed Unit, then 22-86 Speed at Design Point [Hz] should also be used. Closing the valves and reducing the speed until

22-84 Speed at No-Flow [Hz]		
Range:	Function:	
		minimum pressure H_{MIN} is achieved will determine this value.

22-85 Speed at Design Point [RPM]		
Range:	Function:	
Size related*	[par. 22-83 - 60000 RPM]	Resolution 1 RPM. Only visible when 22-82 Work Point Calculation is set to Disable. The speed of the motor at which the system design working point is achieved should be entered here in RPM. Alternatively, the speed in Hz can be entered in 22-86 Speed at Design Point [Hz]. If it has been decided to use RPM in 0-02 Motor Speed Unit, then 22-83 Speed at No-Flow [RPM] should also be used.

22-86 Speed at Design Point [Hz]		
Range:	Function:	
Size related*	[par. 22-84 - par. 4-19 Hz]	Resolution 0.033 Hz. Only visible when 22-82 Work Point Calculation is set to Disable. The speed of the motor at which the system design working point is achieved should be entered here in Hz. Alternatively, the speed in RPM can be entered in 22-85 Speed at Design Point [RPM]. If it has been decided to use Hz in 0-02 Motor Speed Unit, then 22-83 Speed at No-Flow [RPM] should also be used.

22-87 Pressure at No-Flow Speed		
Range:	Function:	
0 *	[0 - par. 22-88]	Enter the pressure H_{MIN} corresponding to Speed at No Flow in Reference/Feedback Units.

Also see 22-82 Work Point Calculation point D.

22-88 Pressure at Rated Speed		
Range:	Function:	
999999.999 *	[par. 22-87 - 999999.999]	Enter the value corresponding to the Pressure at Rated Speed, in Reference/Feedback Units. This value can be defined using the pump datasheet.

See 22-88 Pressure at Rated Speed point A.

22-89 Flow at Design Point		
Range:		Function:
0 *	[0 - 999999.999]	Flow at design point (no units).

Also see 22-82 *Work Point Calculation* point C.

22-90 Flow at Rated Speed		
Range:		Function:
0 *	[0 - 999999.999]	Enter the value corresponding to Flow at Rated Speed. This value can be defined using the pump datasheet.

3.20 Parameters 23-** Time-based Functions

3.20.1 23-0* Timed Actions

Use *Timed Actions* for actions needing to be performed on a daily or weekly basis, e.g., different references for working hours/non-working hours. Up to ten Timed Actions can be programmed in the adjustable frequency drive. The Timed Action number is selected from the list when entering parameter group 23-0* from the LCP. 23-00 ON Time – 23-04 Occurrence then refer to the selected Timed Action number. Each Timed Action is divided into an ON time and an OFF time, in which two different actions may be performed.

The clock control (parameter group 0-7* *Clock Settings*) of Timed Actions can be overridden from *Timed Actions Auto* (Clock Controlled) to *Timed Actions Disabled*, *Constant OFF Actions* or *Constant ON Actions* either in 23-08 *Timed Actions Mode* or with commands applied to the digital inputs ([68] *Timed Actions Disabled*, [69] *Constant OFF Actions* or [70] *Constant ON Actions*, in parameter group 5-1* *Digital Inputs*).

Display lines 2 and 3 in the LCP show the status for Timed Actions Mode (0-23 *Display Line 2 Large* and 0-24 *Display Line 3 Large*, setting [1643] *Timed Actions Status*).

NOTICE!

A change in mode via the digital inputs can only take place if 23-08 *Timed Actions Mode* is set for [0] *Times Actions Auto*.

If commands are applied simultaneously to the digital inputs for Constant OFF and Constant ON, Timed Actions mode will change to Timed Actions Auto and the two commands will be disregarded.

If 0-70 *Date and Time* is not set or the adjustable frequency drive is set to HAND or OFF mode (e.g., via the LCP), the Timed Actions mode will be change to *Timed Actions Disabled*.

The Timed Actions have a higher priority than the same actions/commands activated by the digital inputs or the Smart Logic Controller.

The actions programmed in Timed Actions are merged with corresponding actions from digital inputs, control word via bus and Smart Logic Controller, according to merge rules set up in parameter group 8-5*, *Digital/Bus*.

NOTICE!

The clock (parameter group 0-7*) must be correctly programmed for Timed Actions to function correctly.

NOTICE!

When mounting an analog I/O MCB 109 option card, a battery backup of the date and time is included.

NOTICE!

The PC-based Configuration Tool MCT 10 Set-up Software includes a special guide for easy programming of Timed Actions.

23-00 ON Time		
Array [10]		
Range:		Function:
Size related*	[0 - 0]	Sets the ON time for the Timed Action.
NOTICE! The adjustable frequency drive has no backup of the clock function and the set date/time will reset to default (2000-01-01 00:00) after a power-down unless a real time clock module with backup is installed. In 0-79 <i>Clock Fault</i> , it is possible to program a warning to be issued if the clock has not been set properly, e.g., after a power-down.		

23-01 ON Action		
Arra [10]		
Option:		Function:
		Select the action during ON Time. See 13-52 <i>SL Controller Action</i> for descriptions of the options.
[0]	Disabled	
[1]	No action	
[2]	Select set-up 1	
[3]	Select set-up 2	
[4]	Select set-up 3	
[5]	Select set-up 4	
[10]	Select preset ref 0	
[11]	Select preset ref 1	
[12]	Select preset ref 2	
[13]	Select preset ref 3	
[14]	Select preset ref 4	
[15]	Select preset ref 5	
[16]	Select preset ref 6	
[17]	Select preset ref 7	

23-01 ON Action		
Array [10]		
Option:	Function:	
[18]	Select ramp 1	
[19]	Select ramp 2	
[22]	Run	
[23]	Run reverse	
[24]	Stop	
[26]	DC Brake	
[27]	Coast	
[32]	Set digital out A low	
[33]	Set digital out B low	
[34]	Set digital out C low	
[35]	Set digital out D low	
[36]	Set digital out E low	
[37]	Set digital out F low	
[38]	Set digital out A high	
[39]	Set digital out B high	
[40]	Set digital out C high	
[41]	Set digital out D high	
[42]	Set digital out E high	
[43]	Set digital out F high	
[60]	Reset Counter A	
[61]	Reset Counter B	
[80]	Sleep Mode	
[90]	Set ECB Bypass Mode	
[91]	Set ECB Drive Mode	
[100]	Reset Alarms	

NOTICE!

For choices [32] - [43], see also parameter group 5-3*, *Digital Outputs* and 5-4*, *Relays*.

23-02 OFF Time		
Array [10]		
Range:	Function:	
Size related*	[0 - 0]	Sets the OFF time for the Timed Action.
<p>NOTICE!</p> <p>The adjustable frequency drive has no backup of the clock function and the set date/time will reset to default (2000-01-01 00:00) after a power-down unless a real time clock module with backup is installed. In <i>0-79 Clock Fault</i>, it is possible to program a warning to be issued if the clock has not been set properly, e.g., after a power-down.</p>		

23-03 OFF Action		
Array [10]		
See <i>23-01 ON Action</i> for available actions.		
Option:	Function:	
[0] *	Disabled	

23-04 Occurrence		
Array [10]		
Option:	Function:	
		Select the day(s) to which the timed action applies. Specify working/non-working days in <i>0-81 Working Days</i> , <i>0-82 Additional Working Days</i> and <i>0-83 Additional Non-Working Days</i> .
[0]	All days	
[1]	Working days	
[2]	Non-working days	
[3]	Monday	
[4]	Tuesday	
[5]	Wednesday	
[6]	Thursday	
[7]	Friday	
[8]	Saturday	
[9]	Sunday	

3.20.2 23-1* Maintenance

Wear and tear calls for periodic inspection and service of elements in the application, e.g., motor bearings, feedback sensors and seals or filters. Using preventive maintenance, service intervals may be programmed into the adjustable frequency drive. The adjustable frequency drive will give a message when maintenance is required. Twenty preventive maintenance events can be programmed into the adjustable frequency drive. The following must be specified for each Event:

- Maintenance item (e.g., “Motor Bearings”)
- Maintenance action (e.g., “Replace”)
- Maintenance Time Base (e.g., “Running Hours” or a specific date and time)
- Maintenance Time Interval or the date and time of next maintenance

NOTICE!

To disable a Preventive Maintenance Event the associated 23-12 Maintenance Time Base must be set to [0] Disabled.

Preventive Maintenance can be programmed from the LCP, but use of the PC-based VLT Motion Control Tool MCT 10 Set-up Software is recommended.

ID	Name	Setup 1	Setup 2	Setup 3	Setup 4
2310.0	Maintenance Item	Motor bearings	Motor bearings	Motor bearings	Motor bearings
2310.1	Maintenance Item	Motor bearings	Motor bearings	Motor bearings	Motor bearings
2310.2	Maintenance Item	Motor bearings	Motor bearings	Motor bearings	Motor bearings
2310.3	Maintenance Item	Motor bearings	Motor bearings	Motor bearings	Motor bearings
2310.4	Maintenance Item	Motor bearings	Motor bearings	Motor bearings	Motor bearings
2310.5	Maintenance Item	Motor bearings	Motor bearings	Motor bearings	Motor bearings
2310.6	Maintenance Item	Motor bearings	Motor bearings	Motor bearings	Motor bearings
2310.7	Maintenance Item	Motor bearings	Motor bearings	Motor bearings	Motor bearings
2310.8	Maintenance Item	Motor bearings	Motor bearings	Motor bearings	Motor bearings
2310.9	Maintenance Item	Motor bearings	Motor bearings	Motor bearings	Motor bearings
2310.10	Maintenance Item	Motor bearings	Motor bearings	Motor bearings	Motor bearings
2310.11	Maintenance Item	Motor bearings	Motor bearings	Motor bearings	Motor bearings
2310.12	Maintenance Item	Motor bearings	Motor bearings	Motor bearings	Motor bearings
2310.13	Maintenance Item	Motor bearings	Motor bearings	Motor bearings	Motor bearings
2310.14	Maintenance Item	Motor bearings	Motor bearings	Motor bearings	Motor bearings
2310.15	Maintenance Item	Motor bearings	Motor bearings	Motor bearings	Motor bearings
2310.16	Maintenance Item	Motor bearings	Motor bearings	Motor bearings	Motor bearings
2310.17	Maintenance Item	Motor bearings	Motor bearings	Motor bearings	Motor bearings
2310.18	Maintenance Item	Motor bearings	Motor bearings	Motor bearings	Motor bearings
2310.19	Maintenance Item	Motor bearings	Motor bearings	Motor bearings	Motor bearings
2311.0	Maintenance Action	Lubricate	Lubricate	Lubricates	Lubricate
2311.2	Maintenance Action	Lubricate	Lubricate	Lubricates	Lubricate
2311.3	Maintenance Action	Lubricate	Lubricate	Lubricates	Lubricate
2311.4	Maintenance Action	Lubricate	Lubricate	Lubricates	Lubricate
2311.5	Maintenance Action	Lubricate	Lubricate	Lubricates	Lubricate
2311.6	Maintenance Action	Lubricate	Lubricate	Lubricates	Lubricate

Figure 3.59

The LCP indicates (with a wrench icon and the letter “M”) when it is time for a preventive maintenance action, and can be programmed to be indicated on a digital output in parameter group 5-3*. The Preventive Maintenance Status may be read in 16-96 Maintenance Word. A Preventive Maintenance indication can be reset from a digital input, the FC bus or manually from the LCP through 23-15 Reset Maintenance Word.

A Maintenance Log with the latest 10 loggings can be read from parameter group 18-0* and via the Alarm log key on the LCP after selecting Maintenance Log.

NOTICE!

The Preventive Maintenance Events are defined in a 20 element array. Hence each Preventive Maintenance Event must use the same array element index in 23-10 Maintenance Item to 23-14 Maintenance Date and Time.

23-10 Maintenance Item		
Array [20]		
Option:	Function:	
	Array with 20 elements displayed below parameter number in the display. Press [OK] and step between elements with [◀], [▶], [▲] and [▼].	
	Select the item to be associated with the preventive maintenance event.	
[1]	Motor bearings	
[2]	Fan bearings	
[3]	Pump bearings	
[4]	Valve	
[5]	Pressure transmitter	
[6]	Flow transmitter	
[7]	Temperature transmitter	
[8]	Pump seals	
[9]	Fan belt	
[10]	Filter	
[11]	Drive cooling fan	
[12]	System health check	
[13]	Warranty	
[20]	Maintenance Text 0	
[21]	Maintenance Text 1	
[22]	Maintenance Text 2	
[23]	Maintenance Text 3	
[24]	Maintenance Text 4	
[25]	Maintenance Text 5	

23-11 Maintenance Action		
Array [20]		
Option:	Function:	
	Select the action to be associated with the preventive maintenance event.	
[1]	Lubricate	
[2]	Clean	
[3]	Replace	
[4]	Inspect/Check	
[5]	Overhaul	
[6]	Renew	
[7]	Check	
[20]	Maintenance Text 0	

23-11 Maintenance Action		
Array [20]		
Option:	Function:	
[21]	Maintenance Text 1	
[22]	Maintenance Text 2	
[23]	Maintenance Text 3	
[24]	Maintenance Text 4	
[25]	Maintenance Text 5	

23-12 Maintenance Time Base		
Array [20]		
Option:	Function:	
	Select the time base to be associated with the Preventive Maintenance Event.	
[0]	Disabled	[0] Disabled must be used when disabling the Preventive Maintenance Event.
[1]	Running Hours	[1] Running Hours is the number of hours the motor has been running. Running hours are not reset at power-on. The Maintenance Time Interval must be specified in 23-13 Maintenance Time Interval.
[2]	Operating Hours	[2] Operating Hours is the number of hours the adjustable frequency drive has been running. Operating hours are not reset at power-on. The Maintenance Time Interval must be specified in 23-13 Maintenance Time Interval.
[3]	Date & Time	[3] Date & Time uses the internal clock. The date and time of the next maintenance occurrence must be specified in 23-14 Maintenance Date and Time.

23-13 Maintenance Time Interval		
Array [20]		
Range:	Function:	
1 h* [1 - 2147483647 h]	Set the interval associated with the current preventive maintenance event. This parameter is only used if [1] <i>Running Hours</i> or [2] <i>Operating Hours</i> is selected in 23-12 <i>Maintenance Time Base</i> . The timer is reset from 23-15 <i>Reset Maintenance Word</i> . Example: A Preventive Maintenance Event is set up for Monday at 8:00. 23-12 <i>Maintenance Time Base</i> is [2] <i>Operating hours</i> and 23-13 <i>Maintenance Time Interval</i> is 7 x 24 hours=168 hours. The next maintenance event will be indicated the following Monday at 8:00. If this maintenance event is not reset until Tuesday at 9:00, the next occurrence will be the following Tuesday at 9:00.	

23-14 Maintenance Date and Time		
Array [20]		
Range:	Function:	
Size related* [0 - 0]	Set the date and time for next maintenance occurrence if the preventive maintenance event is based on date/time. Date format depends on the setting in 0-71 <i>Date Format</i> while the time format depends on the setting in 0-72 <i>Time Format</i> . NOTICE! The adjustable frequency drive has no backup of the clock function and the set date/time will reset to default (2000-01-01 00:00) after a power-down. In 0-79 <i>Clock Fault</i> , it is possible to program a warning to be issued if the clock has not been set properly, e.g., after a power-down. The time set must be at least one hour away from the current time! NOTICE! When mounting an analog I/O MCB 109 option card, a battery backup of the date and time is included.	

23-15 Reset Maintenance Word		
Option:	Function:	
	Set this parameter to [1] <i>Do reset</i> to reset the Maintenance Word in 16-96 <i>Maintenance Word</i> and reset the message displayed in the LCP. This parameter will change back to [0] <i>Do not reset</i> when pressing [OK].	
[0]	Do not reset	
[1]	Do reset	

NOTICE!

When messages are reset, Maintenance Item, Action and Maintenance Date/Time are not cancelled.

23-12 *Maintenance Time Base* is set to [0] *Disabled*.

23-16 Maintenance Text		
Array [6]		
Range:	Function:	
0 * [0 - 0]	6 individual texts (Maintenance Text 0...Maintenance Text 5) can be written for use in either 23-10 <i>Maintenance Item</i> or 23-11 <i>Maintenance Action</i> . The text is written according to the guidelines in 0-37 <i>Display Text 1</i> .	

3.20.3 23-5* Energy Log

The adjustable frequency drive is continuously accumulating the consumption of the motor controlled, based on the actual power yielded by the adjustable frequency drive.

These data can be used for an Energy Log function allowing the user to compare and structure the information about the energy consumption related to time.

There are basically two functions:

- Data related to a pre-programmed period, defined by a set date and time for start
- Data related to a predefined period back in time, e.g., the last seven days within the pre-programmed period

For each of the above two functions, the data are stored in a number of counters allowing for selecting the time frame and a split on hours, days or weeks.

The period/split (resolution) can be set in 23-50 *Energy Log Resolution*.

The data are based on the value registered by the kWh counter in the adjustable frequency drive. This counter value can be read in 15-02 kWh Counter containing the accumulated value since the first power-up or latest reset of the counter (15-06 Reset kWh Counter).

All data for the energy log are stored in counters which can be read from 23-53 Energy Log.

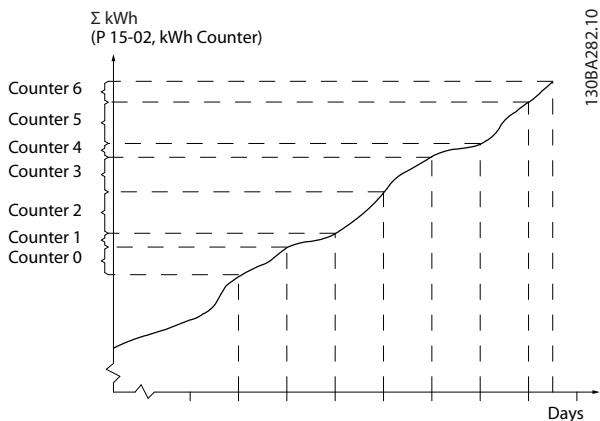

Figure 3.60

Counter 00 always contains the oldest data. A counter covers a period from XX:00 to XX:59 if hours or 00:00 to 23:59 if days.

If logging either the last hours or last days, the counters shift contents at XX:00 every hour or at 00:00 every day. Counter with highest index will always be subject to update (containing data for the actual hour since XX:00 or the actual day since 00:00).

The contents of counters can be displayed as bars on the LCP. Select *Quick Menu, Loggings, Energy Log: Trending Continued Bin/Trending Timed Bin/Trending Comparison*.

23-50 Energy Log Resolution	
Option:	Function:
	Select the desired type of period for logging of consumption. [0] Hour of Day, [1] Day of Week or [2] Day of Month. The counters contain the logging data from the programmed date/time for start (23-51 Period Start) and the numbers of hours/days as programmed for (23-50 Energy Log Resolution). The logging will start on the date programmed in 23-51 Period Start, and continue until one day/week/month has gone. [5] Last 24 Hours, [6] Last 7 Days or [7] Last 5 Weeks. The counters contain data for one day, one week or five weeks back in time and up to the current time.

23-50 Energy Log Resolution	
Option:	Function:
	The logging will start at the date programmed in 23-51 Period Start. In all cases, the period split will refer to operating hours (time where adjustable frequency drive is powered up).
[0]	Hour of Day
[1]	Day of Week
[2]	Day of Month
[5]	Last 24 Hours
[6]	Last 7 Days
[7]	Last 5 Weeks

NOTICE!

The adjustable frequency drive has no backup of the clock function and the set date/time will reset to default (2000-01-01 00:00) after a power-down unless a real time clock module with backup is installed. Consequently, the logging will be stopped until date/time is readjusted in 0-70 Date and Time. In 0-79 Clock Fault, it is possible to program a warning to be issued if the clock has not been set properly, e.g., after a power-down.

23-51 Period Start	
Range:	Function:
Size related* [0 - 0]	Set the date and time at which the energy log starts update of the counters. First data will be stored in counter [00] and start at the time/date programmed in this parameter. Date format will depend on setting in 0-71 Date Format and time format on setting in 0-72 Time Format.

NOTICE!

When mounting an Analog I/O MCB 109 option card, a battery backup of the date and time is included.

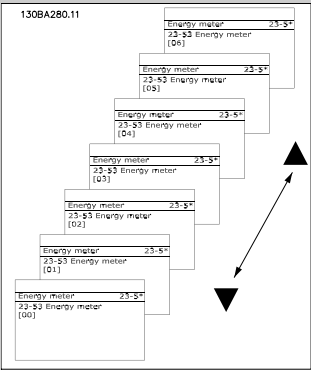
23-53 Energy Log	
Array [31]	
Range:	Function:
0 [0 - * 4294967295]	<p>Array with a number of elements equal to the number of counters ([00]-[xx] below parameter number in display). Press [OK] and Step between elements with [▲] and [▼].</p> <p>Array elements:</p>  <p>Figure 3.62</p> <p>Data from latest period is stored in the counter with the highest index. At power-down, all counter values are stored and resumed at next power-up.</p>

NOTICE!

All counters are automatically reset when changing the setting in 23-50 Energy Log Resolution. At overflow, the update of the counters will stop at maximum value.

NOTICE!

When mounting an Analog I/O MCB 109 option card, a battery backup of the date and time is included.

23-54 Reset Energy Log	
Option:	Function:
	Select [1] Do reset to reset all values in the Energy Log counters shown in 23-53 Energy Log. After pressing OK, the setting of the parameter value will automatically change to [0] Do not reset.
[0]	Do not reset
[1]	Do reset

3.20.4 23-6* Trending

Trending is used to monitor a process variable over a period of time and record how often the data falls into each of ten user-defined data ranges. This is a convenient tool to get a quick overview indicating where to focus on improvement of operation.

Two sets of data for Trending can be created to make it possible to compare current values for a selected operating variable with data for a certain reference period, for the same variable. This reference period can be pre-programmed (23-63 Timed Period Start and 23-64 Timed Period Stop). The two sets of data can be read from 23-61 Continuous Bin Data (current) and 23-62 Timed Bin Data (reference).

It is possible to create trending for following operation variables:

- Power
- Current
- Output frequency
- Motor Speed

The trending function includes ten counters (forming a bin) for each set of data containing the numbers of registrations reflecting how often the operating variable is within each of ten pre-defined intervals. The sorting is based on a relative value of the variable.

The relative value for the operating variable is

$$\text{Actual/Rated} * 100\%$$

for Power and Current and

$$\text{Actual/Max} * 100\%$$

for Output Frequency and Motor Speed.

The size of each interval can be adjusted individually, but default will be 10% for each. Power and current can exceed rated value, but those registrations will be included in the 90%–100% (MAX) counter.

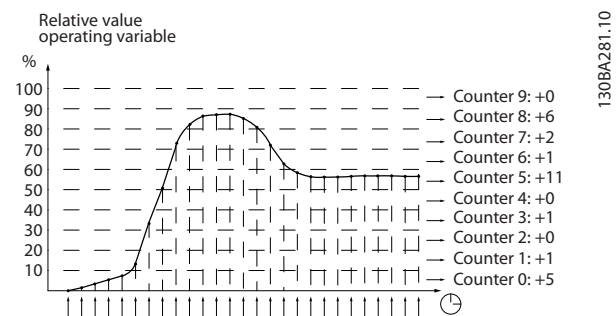

Figure 3.63

Once a second, the value of the operating variable selected is registered. If a value has been registered to equal 13%, the counter "10% - <20%" will be updated with the value "1". If the value stays at 13% for 10s, then "10" will be added to the counter value.

The contents of counters can be displayed as bars on the LCP. Select *Quick Menu* => *Loggings: Trending Continued Bin/Trending Timed Bin/Trending Comparison*.

NOTICE!

The counters starts counting whenever the adjustable frequency drive is powered up. Power cycle shortly after a reset will zero the counters. EEPROM data are updated once per hour.

23-60 Trend Variable		
Option:	Function:	
		Select the desired operating variable to be monitored for trending.
[0]	Power [kW]	Power yielded to the motor. Reference for the relative value is the rated motor power programmed in 1-20 Motor Power [kW] or 1-21 Motor Power [HP]. Actual value can be read in 16-10 Power [kW] or 16-11 Power [hp].
[1]	Current [A]	Output current to the motor. Reference for the relative value is the rated motor current programmed in 1-24 Motor Current. Actual value can be read in 16-14 Motor current.
[2]	Frequency [Hz]	Output frequency to the motor. Reference for the relative value is the maximum output frequency programmed in 4-14 Motor Speed High Limit [Hz]. Actual value can be read in 16-13 Frequency.
[3]	Motor Speed [RPM]	Speed of the motor. Reference for relative value is the maximum motor speed programmed in 4-13 Motor Speed High Limit [RPM].

23-61 Continuous Bin Data		
Range:	Function:	
0 *	[0 - 4294967295]	<p>Array with ten elements ([0]–[9] below parameter number in display). Press [OK] and step between elements using [▲] and [▼].</p> <p>Ten counters with the frequency of occurrence for the operating variable monitored, sorted according to the following intervals:</p> <ul style="list-style-type: none"> Counter [0]: 0%–<10% Counter [1]: 10%–<20% Counter [2]: 20%–<30% Counter [3]: 30%–<40% Counter [4]: 40%–<50% Counter [5]: 50%–<60% Counter [6]: 60%–<70% Counter [7]: 70%–<80% Counter [8]: 80%–<90% Counter [9]: 90%–<100% or Max <p>The above minimum limits for the intervals are the default limits. These can be changed in 23-65 Minimum Bin Value.</p> <p>Starts to count when the adjustable frequency drive is powered up for the first time. All counters can be reset to 0 in 23-66 Reset Continuous Bin Data.</p>

23-62 Timed Bin Data		
Range:	Function:	
0 *	[0 - 4294967295]	<p>Array with ten elements ([0]–[9] below parameter number in display). Press [OK] and step between elements using [▲] and [▼].</p> <p>10 counters with the frequency of occurrence for the operating data monitored sorted according to the intervals as for 23-61 Continuous Bin Data.</p> <p>Starts to count at the date/time programmed in 23-63 Timed Period Start, and stops at the time/date programmed in 23-64 Timed Period Stop. All counters can be reset to 0 in 23-67 Reset Timed Bin Data.</p>

23-63 Timed Period Start		
Range:		Function:
Size related*	[0 - 0]	Set the date and time at which trending starts the update of the timed bin counters. Date format will depend on setting in 0-71 <i>Date Format</i> , and time format on setting in 0-72 <i>Time Format</i> .

NOTICE!

The adjustable frequency drive has no backup of the clock function and the set date/time will reset to default (2000-01-01 00:00) after a power-down unless a real time clock module with backup is installed. Consequently, the logging will be stopped until date/time is readjusted in 0-70 *Date and Time*. In 0-79 *Clock Fault*, it is possible to program a warning to be issued if the clock has not been set properly, e.g., after a power-down.

NOTICE!

When mounting an analog I/O MCB 109 option card, a battery backup of the date and time is included.

23-64 Timed Period Stop		
Range:		Function:
Size related*	[0 - 0]	

NOTICE!

When mounting an Analog I/O MCB 109 option card, a battery backup of the date and time is included.

23-65 Minimum Bin Value		
Range:		Function:
Size related*	[0 - 100 %]	Array with ten elements ([0]–[9] below parameter number in display). Press [OK] and step between elements using [▲] and [▼]. Set the minimum limit for each interval in 23-61 <i>Continuous Bin Data</i> and 23-62 <i>Timed Bin Data</i> . Example: if selecting [1] counter and changing setting from 10% to 12%, [0] counter will be based on the interval 0 – <12% and [1] counter on interval 12% – <20%.

23-66 Reset Continuous Bin Data		
Option:		Function:
[0]	Do not reset	Select [1] <i>Do reset</i> to reset all values in 23-61 <i>Continuous Bin Data</i> . After pressing [OK], the setting of the parameter value will automatically change to [0] <i>Do not reset</i> .
[1]	Do reset	

23-67 Reset Timed Bin Data		
Option:		Function:
		Select [1] <i>Do reset</i> to reset all counters in 23-62 <i>Timed Bin Data</i> . After pressing [OK], the setting of the parameter value will automatically change to [0] <i>Do not reset</i> .
[0]	Do not reset	
[1]	Do reset	

3.20.5 23-8* Payback counter

The VLT® AQUA Drive includes a feature which can give a rough calculation on payback in cases where the adjustable frequency drive has been installed in an existing plant to ensure energy saving by changing from fixed to variable-speed control. Reference for the savings is a set value to represent the average power yielded before the upgrade with variable-speed control.

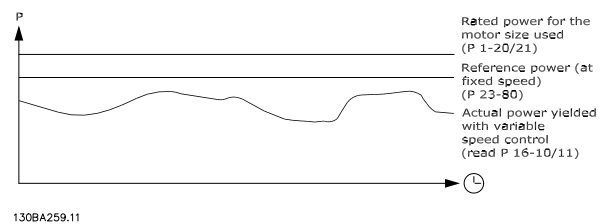

Figure 3.64

The difference between the Reference Power at fixed speed and the Actual Power yielded with speed control represent the actual savings.

As value for the fixed-speed case, the rated motor size (kW) is multiplied with a factor (set in %) representing the power yielded at fixed speed. The difference between this reference power and the actual power is accumulated and stored. The difference in energy can be read in 23-83 *Energy Savings*.

The accumulated value for the difference in power consumption is multiplied with the energy cost in local currency and the investment is subtracted. This calculation for cost savings can also be read in 23-84 *Cost Savings*.

$$\text{Cost Savings} = (\sum (\text{Reference Power} - \text{Actual Power})) * \text{Energy Cost} - \text{Additional Cost}$$

Break even (payback) occurs when the value read in the parameter turns from negative to positive.

It is not possible to reset the Energy Savings counter, but the counter can be stopped any time by setting 23-80 Power Reference Factor, to 0.

Parameter for settings	
Rated Motor Power	1-20 Motor Power [kW]
Power Reference Factor in %	23-80 Power Reference Factor
Energy Cost per kWh	23-81 Energy Cost
Investment	23-82 Investment
Parameters for readout	
Energy Savings	23-83 Energy Savings
Energy Savings	23-83 Energy Savings
Actual Power	16-10 Power [kW]/16-11 Power [hp]
Cost Savings	23-84 Cost Savings

Table 3.28 Parameter Overview

23-80 Power Reference Factor		
Range:		Function:
100 %*	[0 - 100 %]	Set the percentage of the rated motor size (set in 1-20 Motor Power [kW] or 1-21 Motor Power [HP]) which is supposed to represent the average power yielded at the time running with fixed speed (before upgrade with variable speed control). Must be set to a value different from zero to start counting.

23-81 Energy Cost		
Range:		Function:
1 *	[0 - 999999.99]	Set the actual cost for a kWh in local currency. If the energy cost is changed later on, it will impact the calculation for the entire period.

23-82 Investment		
Range:		Function:
0 *	[0 - 999999999]	Set the value of the investment spent on upgrading the plant with speed control, in same currency as used in 23-81 Energy Cost.

23-83 Energy Savings		
Range:		Function:
0 kWh*	[0 - 0 kWh]	This parameter allows for a readout of the accumulated difference between the reference power and the actual output power. If motor size set in hp (1-21 Motor Power [HP]), the equivalent kW value will be used for the Energy Savings.

23-84 Cost Savings		
Range:		Function:
0 *	[0 - 2147483647]	This parameter allows a readout of the calculation based on the above equation (in local currency).

3.21 Parameters 24-** Application Functions 2

Parameter group for application monitoring functions.

3.21.1 24-1* Drive Bypass

Function for activation of external contactors to bypass the adjustable frequency drive for direct online operation of the motor, in case of trip.

24-10 Drive Bypass Function		
Option:	Function:	
		This parameter determines what circumstances will activate the Drive Bypass Function:
[0]	Disabled	
[1]	Enabled	<p>If in normal operation, the automatic Drive Bypass Function is activated in the following conditions:</p> <p>At a Trip Lock or a Trip. After the programmed number of reset attempts, programmed in <i>14-20 Reset Mode</i> or if the bypass delay timer (<i>24-11 Drive Bypass Delay Time</i>) expires before reset attempts have been completed</p> <p>When in Fire mode, the Bypass Function will operate under the following conditions:</p> <p>When experiencing a trip at critical alarms, a Coast or if the Bypass Delay Timer expires before reset attempts have completed when [2] Enabled in Fire mode. The Bypass Function will operate at trip at critical alarms, Coast or if the Bypass Delay Timer expires before reset attempts have been completed.</p>
[2]	Enabled (Fire M Only)	The bypass function will operate at trip at critical alarms, coast or bypass delay timer if the timer expires before reset attempts have completed.

CAUTION

Important! After enabling the Drive Bypass Function, the Safe Stop function (in versions, where included) no longer complies with standard EN 954-1, Cat. 3 installations.

24-11 Drive Bypass Delay Time		
Range:	Function:	
0 s*	[0 - 600 s]	<p>Programmable in 1 s increments. Once the Bypass Function is activated in accordance with the setting in <i>24-10 Drive Bypass Function</i>, the Bypass Delay Timer begins to operate. If the adjustable frequency drive has been set for a number of restart attempts, the timer will continue to run while the adjustable frequency drive tries to restart. If the motor restarts within the time period of the Bypass Delay Timer, then the timer is reset.</p> <p>Should the motor fail to restart at the end of the Bypass Delay Time, the Drive Bypass relay will be activated, which will have been programmed for Bypass in <i>5-40 Function Relay</i>. If a [Relay Delay] has also been programmed in <i>5-41 On Delay, Relay, [Relay]</i> or <i>5-42 Off Delay, Relay, [Relay]</i>, then this time must also elapse before the relay action is performed.</p> <p>Where no restart attempts are programmed, the timer will run for the delay period set in this parameter and will then activate the Drive Bypass relay, which will have been programmed for Bypass in <i>5-40 Function Relay, Function Relay</i>. If a Relay Delay has also been programmed in <i>5-41 On Delay, Relay, On Delay, Relay</i> or <i>5-42 Off Delay, Relay, [Relay]</i>, then this time must also elapse before the relay action is performed.</p>

3.22 Parameters 25-** Cascade Controller

Parameters for configuring the Basic Cascade Controller for sequence control of multiple pumps. For a more application oriented description and wiring examples, see Chapter *Application Examples, item Basic Cascade Controller* in the Design Guide, MG20N.

To configure the Cascade Controller to the actual system and the desired control strategy, it is recommended to follow the sequence below, starting with parameter group 25-0* *System Settings* and next parameter group 25-5* *Alternation Settings*. These parameters can normally be set in advance.

Parameters in 25-2* *Bandwidth Settings* and 25-4* *Staging settings*, will often be dependent on the dynamic of the system and final adjustment to be done at the commissioning of the plant.

NOTICE!

The Cascade Controller is supposed to operate in closed-loop controlled by the built-in PI controller (Closed-loop selected in 1-00 Configuration Mode). If *Open-loop* is selected in 1-00 Configuration Mode, all fixed-speed pumps will be destaged, but the variable-speed pump will still be controlled by the adjustable frequency drive, now as an open-loop configuration:

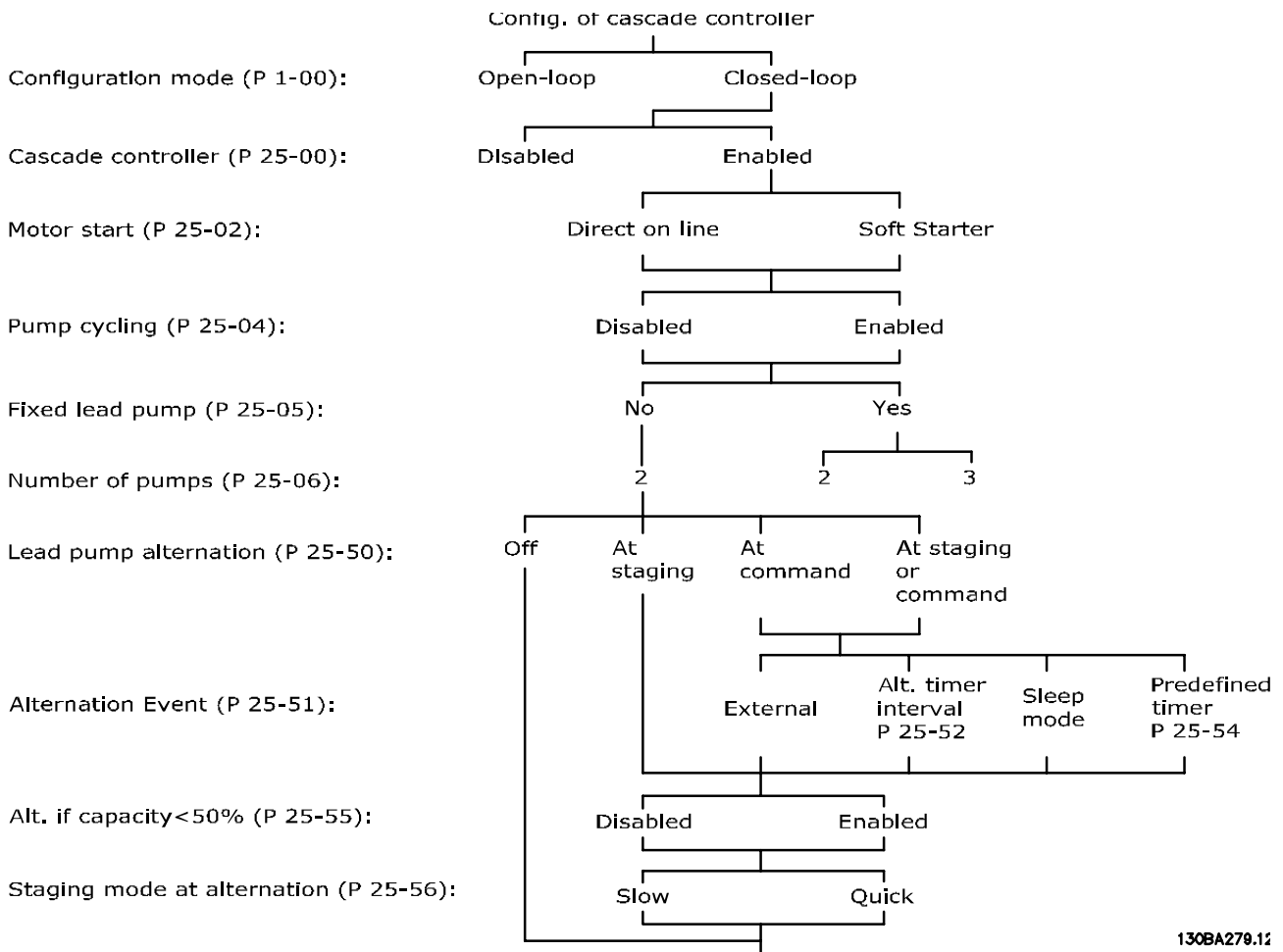

130BA279.12

Figure 3.65

3.22.1 25-0* System Settings

Parameters related to control principles and configuration of the system.

25-00 Cascade Controller		
Option:	Function:	
		For operation of multiple devices (pump/fan) systems where capacity is adapted to actual load by means of speed control combined with on/off control of the devices. For simplicity, only pump systems are described.
[0]	Disabled	The Cascade Controller is not active. All built-in relays assigned to pump motors in the cascade function will be de-energized. If a variable-speed pump is connected to the adjustable frequency drive directly (not controlled by a built-in relay); this pump/fan will be controlled as a single pump system.
[1]	Enabled	The cascade controller is active and will stage/destage pumps according to load on the system.

25-02 Motor Start		
Option:	Function:	
		Motors are directly connected to the line power with a contactor or a soft starter. When the value of <i>25-02 Motor Start</i> is set to an option other than [0] <i>Direct on Line</i> , then <i>25-50 Lead Pump Alternation</i> is automatically set to the default of [0] <i>Direct on Line</i> .
[0]	Direct on Line	Each fixed-speed pump is connected to line directly via a contactor.
[1]	Soft Starter	Each fixed-speed pump is connected to line via a soft starter.
[2]	Star-Delta	

25-04 Pump Cycling		
Option:	Function:	
		To provide equal hours of operation with fixed-speed pumps, the pump use can be cycled. The selection of pump cycling is either "first in – last out" or equal running hours for each pump.
[0]	Disabled	The fixed-speed pumps will be connected in the order 1–2 and disconnected in the order 2–1. (First in–last out).
[1]	Enabled	The fixed-speed pumps will be connected/disconnected to have equal running hours for each pump.

25-05 Fixed Lead Pump		
Option:	Function:	
		Fixed Lead Pump means that the variable-speed pump is connected directly to the adjustable frequency drive, and if a contactor is applied between adjustable frequency drive and pump, this contactor will not be controlled by the adjustable frequency drive. If operating with <i>25-50 Lead Pump Alternation</i> set to other than [0] <i>Off</i> , this parameter must be set to [0] #
[0]	No	The lead pump function can alternate between the pumps controlled by the two built-in relays. One pump must be connected to the built-in RELAY 1, and the other pump to RELAY 2. The pump function (Cascade Pump1 and Cascade Pump2) will automatically be assigned to the relays (maximum two pumps can in this case be controlled from the adjustable frequency drive).
[1]	Yes	The lead pump will be fixed (no alternation) and connected directly to the adjustable frequency drive. The <i>25-50 Lead Pump Alternation</i> is automatically set to [0] <i>Off</i> . Built-in relays Relay 1 and Relay 2 can be assigned to separate fixed-speed pumps. A total of three pumps can be controlled by the adjustable frequency drive.

25-06 Number Of Pumps		
Range:	Function:	
2 * [2 - 9]		The number of pumps connected to the Cascade Controller including the variable-speed pump. If the variable-speed pump is connected directly to the adjustable frequency drive and the other fixed-speed pumps (lag pumps) are controlled by the two built-in relays, three pumps can be controlled. If both the variable-speed and fixed-speed pumps are to be controlled by built-in relays, only two pumps can be connected. If <i>25-05 Fixed Lead Pump</i> , is set to [0] <i>No</i> : one variable-speed pump and one fixed-speed pump; both controlled by built-in relay. If <i>25-05 Fixed Lead Pump</i> is set to [1] <i>Yes</i> : one variable-speed pump and one fixed-speed pump controlled by built-in relay. One lead pump, see <i>25-05 Fixed Lead Pump</i> . Two fixed-speed pumps controlled by built-in relays.

3.22.2 25-2* Bandwidth Settings

Parameters for setting the bandwidth within which the pressure will be allowed to operate before staging/de-staging fixed-speed pumps. Also includes various timers to stabilize the control.

25-20 Staging Bandwidth		
Range:	Function:	
10 %*	[1 - par. 25-21 %]	<p>Set the staging bandwidth (SBW) percentage to accommodate normal system pressure fluctuation.</p> <p>In cascade control systems, to avoid frequent switching of fixed-speed pumps, the desired system pressure is typically kept within a bandwidth rather than at a constant level.</p> <p>The SBW is programmed as a percentage of <i>20-13 Minimum Reference</i> and <i>20-14 Maximum Reference</i>. For example, if the setpoint is 5 bar and the SBW is set to 10%, a system pressure between 4.5 and 5.5 bar is tolerated. No staging or de-staging will occur within this bandwidth.</p>

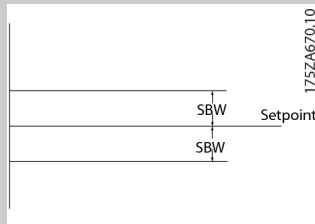

Figure 3.67

25-21 Override Bandwidth		
Range:	Function:	
100 %*	[par. 25-20 - 100 %]	<p>When a large and quick change in the system demand occurs (such as a sudden water demand), the system pressure rapidly changes and an immediate staging or de-staging of a fixed-speed pump becomes necessary to match the requirement. The override bandwidth (OBW) is programmed to override the staging/de-staging timer (<i>25-23 SBW Staging Delay</i> and <i>25-24 SBW De-staging Delay</i>) for immediate response.</p> <p>The OBW must always be programmed to a higher value than the value set in <i>Staging Bandwidth (SBW)</i>, <i>25-20 Staging Bandwidth</i>. The OBW is a percentage of and .</p>

25-21 Override Bandwidth	
Range:	Function:

Figure 3.69

Setting the OBW too close to the SBW could defeat the purpose with frequent staging at momentary pressure changes. Setting the OBW too high might lead to unacceptably high or low pressure in the system while the SBW timers are running. The value can be optimized with increased familiarity with the system. See *25-25 OBW Time*.

To avoid unintended staging during the commissioning phase and fine tuning of the controller, initially leave the OBW at the factory setting of 100% (Off). When the fine tuning is completed, the OBW should be set to the desired value. An initial value of 10% is suggested.

25-22 Fixed Speed Bandwidth		
Range:	Function:	
Size related*	[par. 25-20 - par. 25-21 %]	When the cascade control system is running normally and the adjustable frequency drive issues a trip alarm, it is important to maintain the system head. The Cascade Controller does this by continuing to stage/destage the fixed-speed pump on and off. Due to the fact that keeping the head at the setpoint would require frequent staging and de-staging when only a fixed-speed pump is running, a wider Fixed-speed Bandwidth (FSBW) is used instead of SBW. It is possible to stop the fixed-speed pumps, in case of an alarm situation, by pressing [Off] or [Hand On] or if the signal programmed for Start on digital input goes low.
		If the issued alarm is a trip-lock alarm, the cascade controller must stop the system immediately by cutting out all the fixed-speed pumps. This is basically the same as Emergency Stop (Coast/Coast inverse Command) for the cascade controller.

25-23 SBW Staging Delay		
Range:	Function:	
15 s*	[1 - 3000 s]	Immediate staging of a fixed-speed pump is not desirable when a momentary pressure drop in the system exceeds the staging bandwidth (SBW). Staging is delayed by the length of time programmed. If the pressure increases to within the SBW before the timer has elapsed, the timer is reset.

175ZA672.12

Figure 3.70

25-24 SBW De-staging Delay		
Range:	Function:	
15 s*	[0 - 3000 s]	Immediate de-staging of a fixed-speed pump is not desirable during a momentary pressure

25-24 SBW De-staging Delay		
Range:	Function:	
		increase in the system that exceeds the staging bandwidth (SBW). De-staging is delayed by the length of time programmed. If the pressure decreases to within the SBW before the timer has elapsed, the timer is reset.

175ZA671.11

Figure 3.71

25-25 OBW Time		
Range:	Function:	
10 s*	[0 - 300 s]	Staging a fixed-speed pump creates a momentary pressure peak in the system, which might exceed the Override Bandwidth (OBW). It is not desirable to destage a pump in response to a staging pressure peak. The OBW time can be programmed to prevent staging until the system pressure has stabilized and normal control has been established. Set the timer to a value that allows the system to stabilize after staging. The 10 second factory setting is appropriate in most applications. In highly dynamic systems, a shorter time may be desirable.

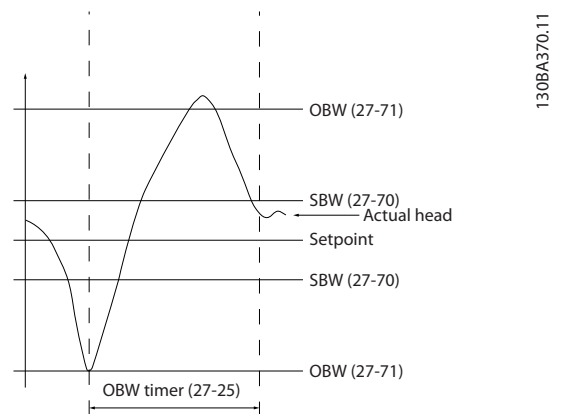

25-26 Destage At No-Flow		
Option:	Function:	
[0]	Disabled	The de-stage at the no-flow parameter ensures that when a no-flow situation occurs, the fixed speed pumps will be de-staged one-by-one until the no-flow signal disappears. This requires that no-flow detection is active. See parameter group 22-2*. If De-stage at No-Flow is disabled the Cascade Controller does not change the normal behavior of the system.
[1]	Enabled	

25-27 Stage Function		
Option:	Function:	
[0]	Disabled	If the Stage Function is set to [0] Disabled, 25-28 Stage Function Time will not be activated.
[1]	Enabled	

25-28 Stage Function Time		
Range:	Function:	
15 s*	[0 - 300 s]	The Stage Function Time is programmed to avoid frequent staging of the fixed-speed pumps. The Stage Function Time starts if it is [1] Enabled by 25-27 Stage Function, and when the variable-speed pump is running at Motor Speed High Limit, 4-13 Motor Speed High Limit [RPM] or 4-14 Motor Speed High Limit [Hz], with at least one fixed-speed pump in the stop position. When the programmed value of the timer expires, a fixed-speed pump is staged.

25-29 Destage Function		
Option:	Function:	
[0]	Disabled	The Destage Function ensures that the lowest numbers of pumps are running to save energy and to avoid dead head water circulation in the variable-speed pump. If the Destage Function is set to [0] Disabled, the 25-30 Destage Function Time will not be activated.
[1]	Enabled	

25-30 Destage Function Time		
Range:	Function:	
15 s*	[0 - 300 s]	The Destage Function Timer is programmable to avoid frequent staging/destaging of the fixed-speed pumps. The Destage Function Time starts when the adjustable speed pump is running at 4-11 Motor Speed Low Limit [RPM] or 4-12 Motor Speed Low Limit [Hz], with one or more fixed-

25-30 Destage Function Time		
Range:	Function:	
		speed pumps in operation and system requirements satisfied. In this situation, the adjustable speed pump contributes a little to the system. When the programmed value of the timer expires, a stage is removed, avoiding dead head water circulation in the adjustable speed pump.

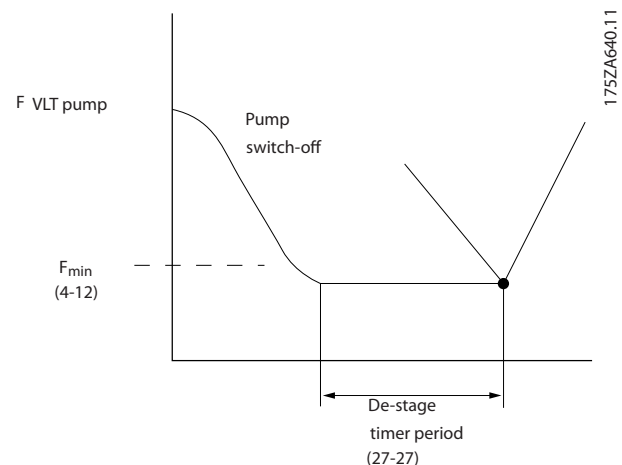

Figure 3.73

3.22.3 25-4* Staging Settings

Parameters determining conditions for staging/de-staging the pumps.

25-40 Ramp-down Delay		
Range:	Function:	
10 s*	[0 - 120 s]	When adding a fixed-speed pump controlled by a soft starter, it is possible to delay the ramp-down of the lead pump until a preset time after the start of the fixed-speed pump to eliminate pressure surges or water hammer in the system. Only to be used if [1] Soft Starter is selected in 25-02 Motor Start.

25-41 Ramp-up Delay		
Range:	Function:	
2 s*	[0 - 12 s]	When removing a fixed-speed pump controlled by a soft starter, it is possible to delay the ramp up of the lead pump until a preset time after stopping the fixed-speed pump to eliminate pressure surges or water hammer in the system. Only to be used if [1] Soft Starter is selected in 25-02 Motor Start.

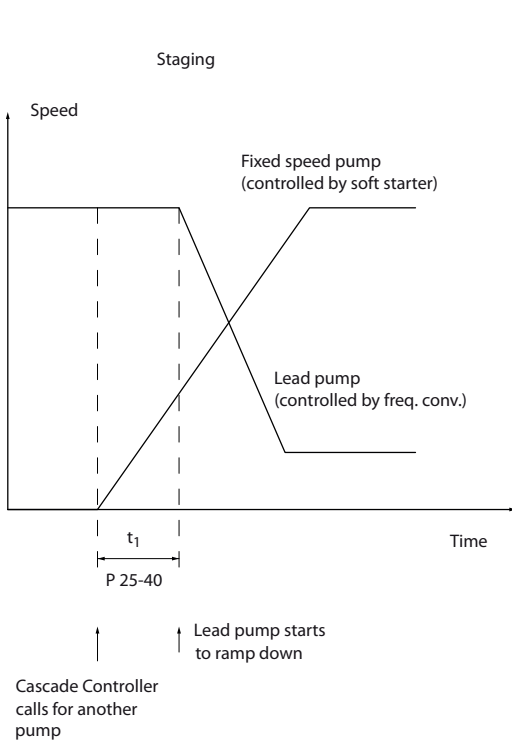

Figure 3.74 Staging

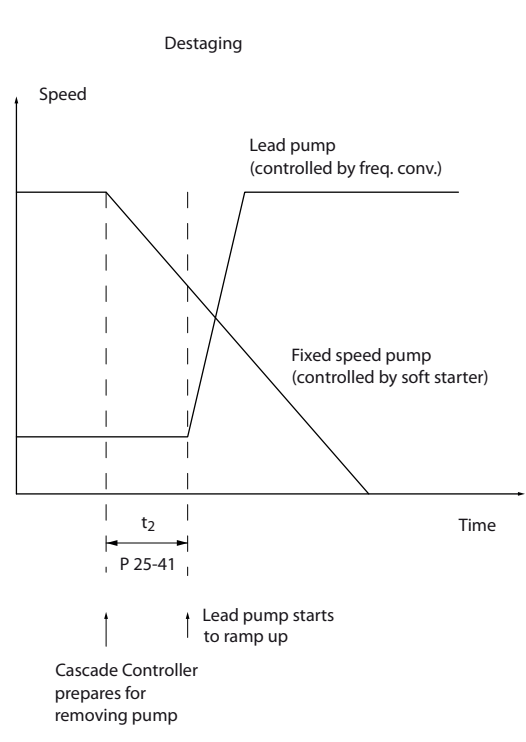

Figure 3.75 De-staging

25-42 Staging Threshold		
Range:	Function:	
Size related* [0 - 100 %]	<p>When adding a fixed-speed pump, to prevent an overshoot of pressure, the variable-speed pump ramps down to a lower speed. When the variable-speed pump reaches the "Staging Speed", the fixed-speed pump is staged on. The Staging Threshold is used to calculate the speed of the variable-speed pump when the "cut-in point" of the fixed-speed pump occurs. The calculation of the staging threshold is the ratio of 4-11 Motor Speed Low Limit [RPM] or 4-12 Motor Speed Low Limit [Hz], to the 4-13 Motor Speed High Limit [RPM] or 4-14 Motor Speed High Limit [Hz], expressed in percent.</p> <p>Staging Threshold must range from</p> $STAGE\% = \frac{LOW}{HIGH} \times 100\%$ <p>to 100%, where n_{LOW} is Motor Speed Low Limit and n_{HIGH} is Motor Speed High Limit.</p>	

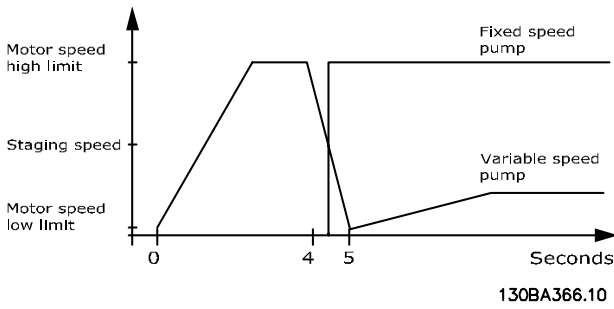

Figure 3.76

130BA366.10

NOTICE!

If the setpoint is reached after staging before the variable-speed pump reaches its minimum speed, the system will enter the closed-loop state as soon as the feedback pressure crosses the setpoint.

25-43 De-staging Threshold	
Range:	Function:
Size related* [0 - 100 %]	When removing a fixed-speed pump, to prevent an undershoot of pressure, the variable-speed pump ramps up to a higher speed. When the variable-speed pump reaches the "De-staging Speed," the fixed-speed pump is de-staged. The De-staging threshold is used to calculate the speed of the variable-speed pump when the de-staging of the fixed-speed pump occurs. The calculation of the De-staging threshold is the ratio of 4-11 Motor Speed Low Limit [RPM] or 4-12 Motor Speed Low Limit [Hz], to the 4-13 Motor Speed High Limit [RPM] or 4-14 Motor Speed High Limit [Hz], expressed in percent. De-staging Threshold must range from $STAGE\% = \frac{LOW}{HIGH} \times 100\%$ to 100%, where n_{LOW} is Motor Speed Low Limit and n_{HIGH} is Motor Speed High Limit.

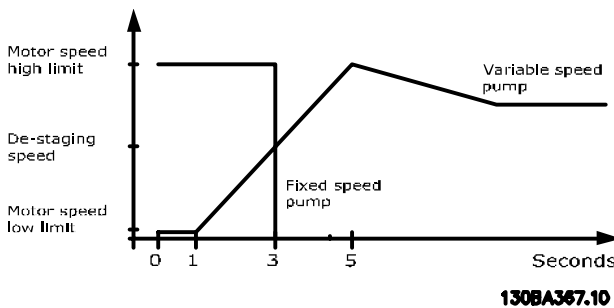

Figure 3.77

130BA367.10

NOTICE!

If the setpoint is reached after staging before the variable-speed pump reaches its maximum speed, the system will enter the closed-loop state as soon as the feedback pressure crosses the setpoint.

3

25-44 Staging Speed [RPM]	
Range:	Function:
0 RPM* [000 - 0 RPM]	Readout of the calculated value below for Staging Speed. When adding a fixed-speed pump, to prevent an overshoot of pressure, the variable-speed pump ramps down to a lower speed. When the variable-speed pump reaches the "Staging Speed", the fixed-speed pump is staged on. Staging Speed calculation is based on 25-42 Staging Threshold, and 4-13 Motor Speed High Limit [RPM]. Staging Speed is calculated with the following formula: $STAGE = HIGH \frac{STAGE\%}{100}$ where n_{HIGH} is Motor Speed High Limit and $n_{STAGE100\%}$ is the value of Staging Threshold.

25-45 Staging Speed [Hz]	
Range:	Function:
0 Hz* [0 - 0 Hz]	Readout of the calculated value below for Staging Speed. When adding a fixed-speed pump, to prevent an overshoot of pressure, the variable-speed pump ramps down to a lower speed. When the variable-speed pump reaches the "Staging Speed", the fixed-speed pump is staged on. Staging Speed calculation is based on 25-42 Staging Threshold, and 4-14 Motor Speed High Limit [Hz]. Staging Speed is calculated with the following formula: $STAGE = HIGH \frac{STAGE\%}{100}$ where n_{HIGH} is Motor Speed High Limit and $n_{STAGE100\%}$ is the value of Staging Threshold.

25-46 De-staging Speed [RPM]		
Range:	Function:	
0 RPM*	[000 - 0 RPM]	<p>Readout of the value calculated below for De-staging Speed. When removing a fixed-speed pump, to prevent an undershoot of pressure, the variable-speed pump ramps up to a higher speed. When the variable-speed pump reaches the "De-staging Speed," the fixed-speed pump is de-staged. De-staging Speed is calculated based on 25-43 <i>De-staging Threshold</i>, and 4-13 <i>Motor Speed High Limit [RPM]</i>.</p> <p>De-staging Speed is calculated with the following formula:</p> $DESTAGE = HIGH \frac{DESTAGE\%}{100}$ <p>where n_{HIGH} is Motor Speed High Limit and $n_{DESTAGE100\%}$ is the value of De-staging Threshold.</p>

25-47 De-staging Speed [Hz]		
Range:	Function:	
0 Hz*	[0 - 0 Hz]	<p>Readout of the value calculated below for De-staging Speed. When removing a fixed-speed pump, to prevent an undershoot of pressure, the variable-speed pump ramps up to a higher speed. When the variable-speed pump reaches the "De-staging Speed," the fixed-speed pump is de-staged. De-staging Speed is calculated based on 25-43 <i>De-staging Threshold</i>, and 4-14 <i>Motor Speed High Limit [Hz]</i>.</p> <p>De-staging Speed is calculated with the following formula:</p> $DESTAGE = HIGH \frac{DESTAGE\%}{100}$ <p>where n_{HIGH} is Motor Speed High Limit and $n_{DESTAGE100\%}$ is the value of De-staging Threshold.</p>

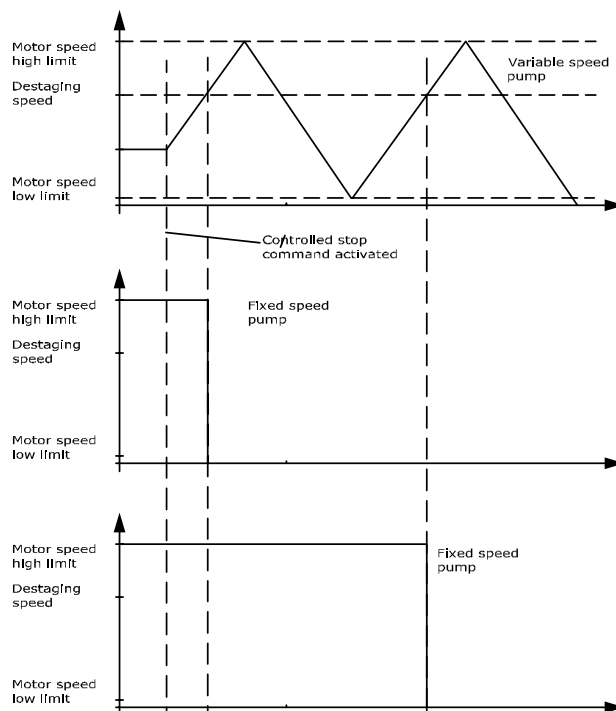

130BA368.10

Figure 3.78

3.22.4 25-5* Alternation Settings

Parameters for defining the conditions for alternation of the variable-speed pump (lead) if selected as of the control strategy.

25-50 Lead Pump Alternation		
Option:	Function:	
		Lead pump alternation equalizes the use of pumps by periodically changing the pump that is speed controlled. This ensures that pumps are equally used over time. Alternation equalizes the usage of pumps by always choosing the pump with the lowest number of used hours to stage on next.
[0]	OFF	No alternation of lead pump function will take place. It is not possible to set this parameter to options other than [0] Off if 25-02 <i>Motor Start</i> is set other than [0] <i>Direct on Line</i> .

NOTICE!

It is not possible to select other than [0] Off if 25-05 *Fixed Lead Pump* is set to [1] Yes.

25-51 Alternation Event		
Option:	Function:	
		This parameter is only active if the options [2] <i>At Command</i> or [3] <i>At Staging or Command</i> have been selected in 25-50 <i>Lead Pump Alternation</i> . If an alternation event is selected, the alternation of lead pump takes place every time the event occurs.
[0]	External	Alternation takes place when a signal is applied to one of the digital inputs on the terminal strip and this input has been assigned to [121] <i>Lead Pump Alternation</i> in parameter group 5-1*, <i>Digital Inputs</i> .
[1]	Alternation Time Interval	Alternation takes place every time 25-52 <i>Alternation Time Interval</i> expires.
[2]	Sleep Mode	Alternation takes place each time the lead pump goes into Sleep mode. 20-23 <i>Setpoint 3</i> must be set to [1] <i>Sleep Mode</i> or an external signal applied for this function.
[3]	Predefined Time	Alternation takes place at a defined time of the day. If 25-54 <i>Alternation Predefined Time</i> is set, the alternation is carried out every day at the specified time. Default time is midnight (00:00 or 12:00AM depending on the time format).

25-52 Alternation Time Interval		
Range:	Function:	
24 h*	[1 - 999 h]	If [1] <i>Alternation Time Interval</i> option in 25-51 <i>Alternation Event</i> is selected, the alternation of the variable-speed pump takes place every time the Alternation Time Interval expires (can be checked out in 25-53 <i>Alternation Timer Value</i>).

25-53 Alternation Timer Value		
Range:	Function:	
0 *	[0 - 0]	Readout parameter for the Alternation Time Interval value set in 25-52 <i>Alternation Time Interval</i> .

25-54 Alternation Predefined Time		
Range:	Function:	
Size related*	[0 - 0]	If option [3] <i>Predefined Time</i> in 25-51 <i>Alternation Event</i> is selected, the variable-speed pump alternation is carried out every day at the specified time set in Alternation Predefined Time. Default time is midnight (00:00 or 12:00AM depending on the time format).

25-55 Alternate if Load < 50%		
Option:	Function:	
		If [1] <i>Enabled</i> is selected, the pump alternation can only occur if the capacity is equal to or below 50%. The capacity calculation is the ratio of running pumps (including the variable-speed pump) to the total number of available pumps (including variable-speed pump, but not those interlocked). $Capacity = \frac{N_{RUNNING}}{N_{TOTAL}} \times 100\%$ For the Basic Cascade Controller, all pumps are equal size.
[0]	Disabled	The lead pump alternation will take place at any pump capacity.
[1]	Enabled	The lead pump function will be alternated only if the numbers of pumps running are providing less than 50% of total pump capacity.

NOTICE!

Only valid if 25-50 *Lead Pump Alternation* is different from [0] *Off*.

25-56 Staging Mode at Alternation		
Option:	Function:	
[0]	Slow	
[1]	Quick	This parameter is only active if the option selected in 25-50 <i>Lead Pump Alternation</i> is different from [0] <i>Off</i> . Two types of staging and de-staging of pumps are possible. Slow transfer makes staging and de-staging smooth. Quick transfer makes staging and de-staging as fast as possible; the variable-speed pump is simply cut out (coasted). [0] <i>Slow</i> : At alternation, the variable-speed pump is ramped up to maximum speed and then ramped down to a stand still. [1] <i>Quick</i> : At alternation, the variable-speed pump is ramped up to maximum speed and then coasted to stand still. <i>Figure 3.79</i> and <i>Figure 3.80</i> show Alternation in both Quick and Slow configurations.

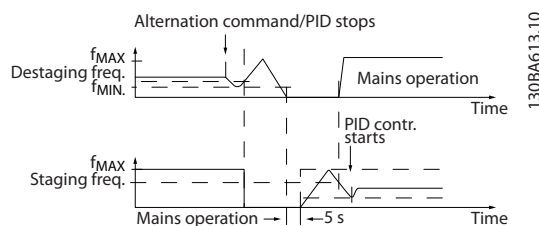

Figure 3.79 Slow Configuration

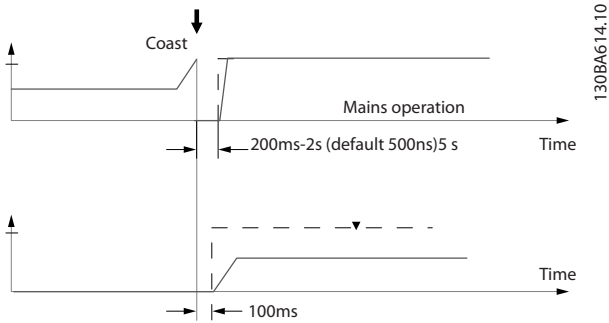

Figure 3.80 Quick Configuration

25-58 Run Next Pump Delay		
Range:	Function:	
0.1 s*	[0.1 - 5 s]	This parameter is only active if the option selected in 25-50 <i>Lead Pump Alternation</i> is different from [0] <i>Off</i> . This parameter sets the time between stopping the old variable-speed pump and starting another pump as a new variable-speed pump. Refer to 25-56 <i>Staging Mode at Alternation</i> , the figure which describes staging and alternation.

25-59 Run-on Line Delay		
Range:	Function:	
0.5 s*	[par. 25-58 - 5 s]	This parameter is only active if the option selected in 25-50 <i>Lead Pump Alternation</i> is different from [0] <i>Off</i> . This parameter sets the time between stopping the old variable-speed pump and starting this pump as a new fixed-speed pump. Refer to for a description of staging and alternation.

3.22.5 25-8* Status

Readout parameters informing about the operating status of the Cascade Controller and the pumps controlled.

25-80 Cascade Status		
Range:	Function:	
0 *	[0 - 0]	Readout of the status of the Cascade Controller.

25-81 Pump Status		
Range:	Function:	
0 *	[0 - 0]	Pump status shows the status for the number of pumps selected in 25-06 <i>Number Of Pumps</i> . It is a readout of the status for each of the pumps showing a string, which consists of pump number and the current status of the pump.

25-81 Pump Status		
Range:	Function:	
		Example: Readout is with the abbreviation like "1:D 2:O". This means that Pump 1 is running and speed controlled by the adjustable frequency drive and Pump 2 is stopped.

25-82 Lead Pump		
Range:	Function:	
0 *	[0 - par. 25-06]	Readout parameter for the actual variable-speed pump in the system. The Lead Pump parameter is updated to reflect the current variable-speed pump in the system when an alternation takes place. If no lead pump is selected (Cascade Controller disabled or all pumps interlocked), the display will show NONE.

25-83 Relay Status		
Range:	Function:	
0 *	[0 - 0]	Readout of the status for each of the relays assigned to control the pumps. Readout of the status for each of the relays assigned to control the pumps. Readout of the status for each of the relays assigned to control the pumps.

25-84 Pump ON Time		
Range:	Function:	
0 h*	[0 - 2147483647 h]	Readout of the value for pump ON Time. The cascade controller has separate counters for the pumps and for the relays that control the pumps. Pump ON Time monitors the "operating hours" of each pump. The value of each Pump ON Time counter can be reset to 0 by writing in the parameter, e.g., if the pump is replaced in case of service.

25-85 Relay ON Time		
Range:	Function:	
0 h*	[0 - 2147483647 h]	Readout of the value for Relay ON time. The cascade controller has separate counters for the pumps and for the relays that control the pumps. Pump cycling is always done based on the relay counters; otherwise, it would always use the new pump if a pump is replaced and its value in 25-84 <i>Pump ON Time</i> is reset. To use 25-04 <i>Pump Cycling</i> , the Cascade Controller monitors the Relay ON time.

25-86 Reset Relay Counters		
Option:	Function:	
		Resets all elements in 25-85 Relay ON Time counters.
[0]	Do not reset	
[1]	Do reset	

3.22.6 25-9* Service

Parameters used in case of service on one or more of the pumps controlled.

25-90 Pump Interlock		
Option:	Function:	
		In this parameter, it is possible to disable one or more of the fixed-lead pumps. For example, the pump will not be selected for staging on even if it is the next pump in the operation sequence. It is not possible to disable the lead pump with the pump Interlock command. The digital input interlocks are selected as <i>Pump 1-3 Interlock</i> [130–132] in parameter group 5-1*, <i>Digital Inputs</i> .
[0]	Off	The pump is active for staging/de-staging.
[1]	On	The Pump Interlock command is given. If a pump is running, it is immediately destaged. If the pump is not running, it is not allowed to stage on.

25-91 Manual Alternation		
Range:	Function:	
0 * [0 - par. 25-06]		Readout parameter for the actual variable-speed pump in the system. The Lead Pump parameter is updated to reflect the current variable-speed pump in the system when an alternation takes place. If no lead pump is selected (Cascade Controller disabled or all pumps interlocked) the display will show NONE.

3.23 Parameters 26-** Analog I/O Option MCB 109

3.23.1 26-** Analog I/O Option MCB 109

The Analog I/O Option MCB 109 extends the functionality of VLT® AQUA Drive FC 200 Series adjustable frequency drives, by adding a number of additional, programmable analog inputs and outputs. This could be especially useful in control installations in which the adjustable frequency drive may be used as decentral I/O, obviating the need for an outstation, and thus reducing cost. It also provides flexibility in project planning.

NOTICE!

The maximum current for the analog outputs 0–10 V is 1 mA.

NOTICE!

Where Live Zero Monitoring is used, it is important that any analog inputs not being used for the frequency controller, i.e., being used as part of the building management system decentral I/O, should have their Live Zero function disabled.

Terminal	Parameters
Analog inputs	
X42/1	26-00, 26-1*
X42/3	26-01, 26-2*
X42/5	26-02, 26-3*
Analog outputs	
X42/7	26-4*
X42/9	26-5*
X42/11	26-6*
Analog inputs	
53	6-1*
54	6-2*
Analog output	
42	6-5*
Relays	
Relay 1 Term 1, 2, 3	5-4*
Relay 2 Term 4, 5, 6	5-4*

Table 3.29 Relevant Parameters

It is also possible to read the analog inputs, write to the analog outputs and control the relays, using communication via the serial bus. In this instance, these are the relevant parameters.

Terminal	Parameters
Analog inputs (read)	
X42/1	18-30
X42/3	18-31
X42/5	18-32
Analog outputs (write)	
X42/7	18-33
X42/9	18-34
X42/11	18-35
Analog inputs (read)	
53	16-62
54	16-64
Analog output	
42	6-63
Relays	
Relay 1 Term 1, 2, 3	16-71
Relay 2 Term 4, 5, 6	16-71
NOTICE!	
The relay outputs must be enabled via Control Word Bit 11 (Relay 1) and Bit 12 (Relay 2)	

Table 3.30 Relevant Parameters

Setting of on-board Real Time Clock.

The analog I/O option incorporates a real time clock with battery backup. This can be used as a backup of the clock function included in the adjustable frequency drive as standard. See parameter group 0-7*, *Clock Settings*.

The analog I/O option can be used for the control of devices such as servos or valves, using the extended closed-loop facility, thus removing control from the existing control system. See 3.18 *Parameters 21-** Extended Closed Loop*. There are three independent closed-loop PID controllers.

26-00 Terminal X42/1 Mode	
Option:	Function:
	Terminal X42/1 can be programmed as an analog input accepting a voltage or input from either Pt1000 (1000 Ω at 32° F [0°C]) or Ni 1000 (1000 Ω at 32° F [0°C]) temperature sensors. Select the desired mode. [2] Pt 1000 [°C] and [4] Ni 1000 [°C] if operating in Celsius - [3] Pt 1000 [°F] and [5] Ni 1000 [°F] if operating in Fahrenheit. NOTICE! If the input is not in use, it must be set for voltage! If set for temperature and used as feedback, the unit must be set for either Celsius or Fahrenheit (20-12 Reference/Feedback Unit, 21-10 Ext. 1 Ref./Feedback Unit, 21-30 Ext. 2 Ref./Feedback Unit or 21-50 Ext. 3 Ref./Feedback Unit).
[1]	Voltage
[2]	Pt 1000 [°C]
[3]	Pt 1000 [°F]
[4]	Ni 1000 [°C]
[5]	Ni 1000 [°F]

26-01 Terminal X42/3 Mode	
Option:	Function:
	Terminal X42/3 can be programmed as an analog input accepting a voltage or input from either Pt 1000 or Ni 1000 temperature sensors. Select the desired mode. [2] Pt 1000 [°C] and [4] Ni 1000 [°C] if operating in Celsius - [3] Pt 1000 [°F] and [5] Ni 1000 [°F] if operating in Fahrenheit. WARNING If the input is not in use, it must be set for voltage! If set for temperature and used as feedback, the unit must be set for either Celsius or Fahrenheit (20-12 Reference/Feedback Unit, 21-10 Ext. 1 Ref./Feedback Unit, 21-30 Ext. 2 Ref./Feedback Unit or 21-50 Ext. 3 Ref./Feedback Unit).
[1]	Voltage
[2]	Pt 1000 [°C]
[3]	Pt 1000 [°F]
[4]	Ni 1000 [°C]

26-01 Terminal X42/3 Mode	
Option:	Function:
[5]	Ni 1000 [°F]

26-02 Terminal X42/5 Mode	
Option:	Function:
	Terminal X42/5 can be programmed as an analog input accepting a voltage or input from either Pt 1000 (1000 Ω at 32° F [0°C]) or Ni 1000 (1000 Ω at 32° F [0°C]) temperature sensors. Select the desired mode. [2] Pt 1000 [°C] and [4] Ni 1000 [°C] if operating in Celsius - [3] Pt 1000 [°F] and [5] Ni 1000 [°F] if operating in Fahrenheit. NOTICE! If the input is not in use, it must be set for voltage! If set for temperature and used as feedback, the unit must be set for either Celsius or Fahrenheit (20-12 Reference/Feedback Unit, 21-10 Ext. 1 Ref./Feedback Unit, 21-30 Ext. 2 Ref./Feedback Unit or 21-50 Ext. 3 Ref./Feedback Unit).
[1]	Voltage
[2]	Pt 1000 [°C]
[3]	Pt 1000 [°F]
[4]	Ni 1000 [°C]
[5]	Ni 1000 [°F]

26-10 Terminal X42/1 Low Voltage		
Range:	Function:	
0.07 V* [0 - par. 6-31 V]	Enter the low voltage value. This analog input scaling value should correspond to the low reference/feedback value set in 26-14 Term. X42/1 Low Ref./Feedb. Value.	

26-11 Terminal X42/1 High Voltage		
Range:	Function:	
10 V* [par. 6-30 - 10 V]	Enter the high voltage value. This analog input scaling value should correspond to the high reference/feedback value set in 26-15 Term. X42/1 High Ref./Feedb. Value.	

26-14 Term. X42/1 Low Ref./Feedb. Value		
Range:	Function:	
0 * [-999999.999 - 999999.999]	Enter the analog input scaling value that corresponds to the low voltage value set in 26-10 Terminal X42/1 Low Voltage.	

26-15 Term. X42/1 High Ref./Feedb. Value		
Range:	Function:	
100 * [-999999.999 - 999999.999]	Enter the analog input scaling value that corresponds to the high voltage value set in 26-11 Terminal X42/1 High Voltage.	

26-16 Term. X42/1 Filter Time Constant		
Range:	Function:	
0.001 s* [0.001 - 10 s]	Enter the time constant. This is a first-order digital low pass filter time constant for suppressing noise in terminal X42/1. A high time constant value improves dampening but also increases the time delay through the filter.	
<p>NOTICE! This parameter cannot be adjusted while the motor is running.</p>		

26-17 Term. X42/1 Live Zero		
Option:	Function:	
	This parameter makes it possible to enable Live Zero monitoring. For example, where the analog input is a part of the adjustable frequency drive control, rather than being used as part of a decentral I/O system, such as a building management system.	
[0]	Disabled	
[1]	Enabled	

26-20 Terminal X42/3 Low Voltage		
Range:	Function:	
0.07 V* [0 - par. 6-31 V]	Enter the low voltage value. This analog input scaling value should correspond to the low reference/feedback value set in 26-24 Term. X42/3 Low Ref./Feedb. Value.	

26-21 Terminal X42/3 High Voltage		
Range:	Function:	
10 V* [par. 6-30 - 10 V]	Enter the high voltage value. This analog input scaling value should correspond to the high reference/feedback value set in 26-25 Term. X42/3 High Ref./Feedb. Value.	

26-24 Term. X42/3 Low Ref./Feedb. Value		
Range:	Function:	
0 * [-999999.999 - 999999.999]	Enter the analog input scaling value that corresponds to the low voltage value set in 26-20 Terminal X42/3 Low Voltage.	

26-25 Term. X42/3 High Ref./Feedb. Value		
Range:	Function:	
100 * [-999999.999 - 999999.999]	Enter the analog input scaling value that corresponds to the high voltage value set in 26-21 Terminal X42/3 High Voltage.	

26-26 Term. X42/3 Filter Time Constant		
Range:	Function:	
0.001 s* [0.001 - 10 s]	Enter the time constant. This is a first-order digital low pass filter time constant for suppressing noise in terminal X42/3. A high time constant value improves dampening but also increases the time delay through the filter.	
<p>NOTICE! This parameter cannot be adjusted while the motor is running.</p>		

26-27 Term. X42/3 Live Zero		
Option:	Function:	
	This parameter makes it possible to enable Live Zero monitoring. For example, where the analog input is a part of the adjustable frequency drive control, rather than being used as part of a decentral I/O system, such as a building management system.	
[0]	Disabled	
[1]	Enabled	

26-30 Terminal X42/5 Low Voltage		
Range:	Function:	
0.07 V* [0 - par. 6-31 V]	Enter the low voltage value. This analog input scaling value should correspond to the low reference/feedback value set in 26-34 Term. X42/5 Low Ref./Feedb. Value.	

26-31 Terminal X42/5 High Voltage		
Range:	Function:	
10 V* [par. 6-30 - 10 V]	Enter the high voltage value. This analog input scaling value should correspond to the high reference/feedback value set in 26-35 Term. X42/5 High Ref./Feedb. Value.	

26-34 Term. X42/5 Low Ref./Feedb. Value		
Range:	Function:	
0 * [-999999.999 - 999999.999]	Enter the analog input scaling value that corresponds to the low voltage value set in 26-30 Terminal X42/5 Low Voltage.	

26-35 Term. X42/5 High Ref./Feedb. Value		
Range:	Function:	
100 * [-999999.999 - 999999.999]	Enter the analog input scaling value that corresponds to the high voltage value set in 26-21 Terminal X42/3 High Voltage.	

26-36 Term. X42/5 Filter Time Constant		
Range:	Function:	
0.001 s* [0.001 - 10 s]	Enter the time constant. This is a first-order digital low pass filter time constant for suppressing noise in terminal X42/5. A high time constant value improves dampening but also increases the time delay through the filter.	
	NOTICE! This parameter cannot be adjusted while the motor is running.	

26-37 Term. X42/5 Live Zero		
Option:	Function:	
	This parameter makes it possible to enable Live Zero monitoring. For example, where the analog input is a part of the adjustable frequency drive control, rather than being used as part of a decentral I/O system, such as a building management system.	
[0]	Disabled	
[1]	Enabled	

26-40 Terminal X42/7 Output		
Option:	Function:	
	Set the function of terminal X42/7 as an analog voltage output.	
[0]	No operation	
[100]	Output freq. 0-100	0–100 Hz, (0–20 mA)
[101]	Reference Min-Max	Minimum reference - Maximum reference, (0–20 mA)
[102]	Feedback +200%	-200% to +200% of 3-03 Maximum Reference, (0–20 mA)
[103]	Motor cur. 0-Imax	0 - Inverter Max. Current (16-37 Inv. Max. Current), (0–20 mA)
[104]	Torque 0-Tlim	0 - Torque limit (4-16 Torque Limit Motor Mode), (0–20 mA)
[105]	Torque 0-Tnom	0 - Motor rated torque, (0–20 mA)
[106]	Power 0-Pnom	0 - Motor rated power, (0–20 mA)

26-40 Terminal X42/7 Output		
Option:	Function:	
[107]	Speed 0-HighLim	0 - Speed High Limit (4-13 Motor Speed High Limit [RPM] and 4-14 Motor Speed High Limit [Hz]), (0–20 mA)
[113]	Ext. Closed-loop 1	0–100%, (0–20 mA)
[114]	Ext. Closed-loop 2	0–100%, (0–20 mA)
[115]	Ext. Closed-loop 3	0–100%, (0–20 mA)
[139]	Bus ctrl.	0–100%, (0–20 mA)
[141]	Bus ctrl t.o.	0–100%, (0–20 mA)

26-41 Terminal X42/7 Min. Scale		
Range:	Function:	
0 %*	[0 - 200 %]	

26-42 Terminal X42/7 Max. Scale		
Range:	Function:	
100 %*	[0 - 200 %]	

See principal graph for 6-52 Terminal 42 Output Max Scale.

26-43 Terminal X42/7 Bus Control		
Range:	Function:	
0 %*	[0 - 100 %]	

26-44 Terminal X42/7 Timeout Preset		
Range:	Function:	
0 %*	[0 - 100 %]	

26-50 Terminal X42/9 Output		
Option:	Function:	
	Set the function of terminal X42/9.	
[0]	No operation	
[100]	Output freq. 0-100	0–100 Hz, (0–20 mA)
[101]	Reference Min-Max	Minimum reference - Maximum reference, (0–20 mA)
[102]	Feedback +200%	-200% to +200% of 3-03 Maximum Reference, (0–20 mA)
[103]	Motor cur. 0-Imax	0 - Inverter Max. Current (16-37 Inv. Max. Current), (0–20 mA)
[104]	Torque 0-Tlim	0 - Torque limit (4-16 Torque Limit Motor Mode), (0–20 mA)
[105]	Torque 0-Tnom	0 - Motor rated torque, (0–20 mA)
[106]	Power 0-Pnom	0 - Motor rated power, (0–20 mA)
[107]	Speed 0-HighLim	0 - Speed High Limit (4-13 Motor Speed High Limit [RPM] and 4-14 Motor Speed High Limit [Hz]), (0–20 mA)
[113]	Ext. Closed-loop 1	0–100%, (0–20 mA)

26-50 Terminal X42/9 Output		
Option:	Function:	
[114]	Ext. Closed-loop 2	0–100%, (0–20 mA)
[115]	Ext. Closed-loop 3	0–100%, (0–20 mA)
[139]	Bus ctrl.	0–100%, (0–20 mA)
[141]	Bus ctrl t.o.	0–100%, (0–20 mA)

26-51 Terminal X42/9 Min. Scale		
Range:	Function:	
0 %*	[0 - 200 %]	

See principle graph for 6-51 Terminal 42 Output Min Scale.

26-52 Terminal X42/9 Max. Scale		
Range:	Function:	
100 %*	[0 - 200 %]	

See principal graph for 6-52 Terminal 42 Output Max Scale.

26-53 Terminal X42/9 Bus Control		
Range:	Function:	
0 %*	[0 - 100 %]	

26-54 Terminal X42/9 Timeout Preset		
Range:	Function:	
0 %*	[0 - 100 %]	

26-60 Terminal X42/11 Output		
Option:	Function:	
		Set the function of terminal X42/11.
[0]	No operation	
[100]	Output freq. 0-100	0–100 Hz, (0–20 mA)
[101]	Reference Min-Max	Minimum reference - Maximum reference, (0–20 mA)
[102]	Feedback +-200%	-200% to +200% of 3-03 Maximum Reference, (0–20 mA)
[103]	Motor cur. 0-lmax	0 - Inverter Max. Current (16-37 Inv. Max. Current), (0–20 mA)
[104]	Torque 0-Tlim	0 - Torque limit (4-16 Torque Limit Motor Mode), (0–20 mA)
[105]	Torque 0-Tnom	0 - Motor rated torque, (0–20 mA)
[106]	Power 0-Pnom	0 - Motor rated power, (0–20 mA)
[107]	Speed 0-HighLim	0 - Speed High Limit (4-13 Motor Speed High Limit [RPM] and 4-14 Motor Speed High Limit [Hz]), (0–20 mA)
[113]	Ext. Closed-loop 1	0–100%, (0–20 mA)
[114]	Ext. Closed-loop 2	0–100%, (0–20 mA)
[115]	Ext. Closed-loop 3	0–100%, (0–20 mA)

26-60 Terminal X42/11 Output		
Option:	Function:	
[139]	Bus ctrl.	0–100%, (0–20 mA)
[141]	Bus ctrl t.o.	0–100%, (0–20 mA)

26-61 Terminal X42/11 Min. Scale		
Range:	Function:	
0 %*	[0 - 200 %]	

See principle graph for 6-51 Terminal 42 Output Min Scale.

26-62 Terminal X42/11 Max. Scale		
Range:	Function:	
100 %*	[0 - 200 %]	

See principal graph for 6-52 Terminal 42 Output Max Scale.

26-63 Terminal X42/11 Bus Control		
Range:	Function:	
0 %*	[0 - 100 %]	

26-64 Terminal X42/11 Timeout Preset		
Range:	Function:	
0 %*	[0 - 100 %]	

3.24 Parameters 29-** Water Application Functions

3.24.1 29-** Water Application Functions

The group contains parameters used for monitoring water/waste water applications.

3.24.2 29-0* Pipe Fill function

In water supply systems, water hammering can occur when filling the pipes too fast. It is therefore desirable to limit the filling rate. Pipe Fill Mode eliminates the occurrence of water hammering associated with the rapid exhausting of air from the piping system by filling the pipes at a low rate.

This function is used in horizontal, vertical and mixed piping systems. Due to the fact that the pressure in horizontal pipe systems does not climb as the system fills, filling horizontal pipe systems requires a user specified speed to fill, for a user specified time and/or until a user specified pressure setpoint is reached.

The best way to fill a vertical pipe system is to use the PID function to ramp the pressure at a user specified rate between the motor speed low limit and a user specified pressure.

The pipe fill function uses a combination of above to ensure a safe filling in any system.

No matter which system, the pipe fill mode will start using the constant speed set in 29-01 Pipe Fill Speed [RPM] until the pipe fill time in 29-03 Pipe Fill Time has expired, thereafter filling will continue with the filling ramp set in 29-04 Pipe Fill Rate until the filling setpoint specified in 29-05 Filled Setpoint is reached.

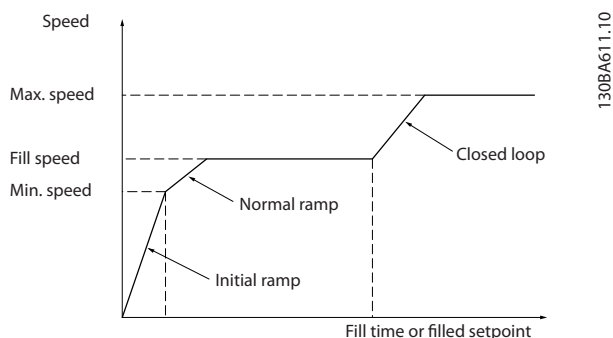

Figure 3.81 Horizontal Pipe System

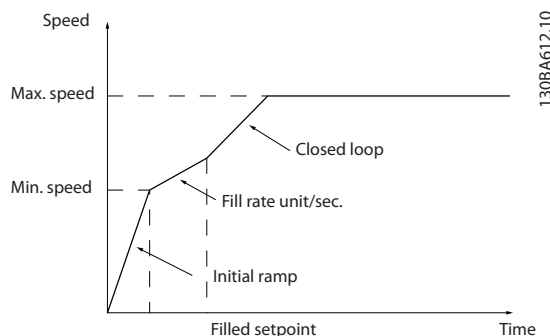

Figure 3.82 Vertical Pipe System

29-00 Pipe Fill Enable		
Option:	Function:	
[0]	Disabled	Select Enabled to fill pipes at a user-specified rate.
[1]	Enabled	Select Enabled to fill pipes with a user specified rate.

29-01 Pipe Fill Speed [RPM]		
Range:	Function:	
Size related*	[par. 4-11 - par. 4-13 RPM]	Set the filling speed for filling horizontal pipe systems. The speed can be selected in Hz or RPM depending on the choices made in 4-11 Motor Speed Low Limit [RPM]/4-13 Motor Speed High Limit [RPM] or in 4-12 Motor Speed Low Limit [Hz]/4-14 Motor Speed High Limit [Hz].

29-02 Pipe Fill Speed [Hz]		
Range:	Function:	
Size related*	[par. 4-12 - par. 4-14 Hz]	Set the filling speed for filling horizontal pipe systems. The speed can be selected in Hz or RPM depending on the choices made in 4-11 Motor Speed Low Limit [RPM]/4-13 Motor Speed High Limit [RPM] or in 4-12 Motor Speed Low Limit [Hz]/4-14 Motor Speed High Limit [Hz].

29-03 Pipe Fill Time		
Range:	Function:	
0 s*	[0 - 3600 s]	Set the specified time for pipe filling of horizontal pipe systems.

29-04 Pipe Fill Rate		
Range:		Function:
0.001 ProcessCtrlUnit*	[0.001 - 999999.999 ProcessCtrlUnit]	Specifies the filling rate in units/second using the PI controller. Filling rate units are feedback units/second. This function is used for filling up vertical pipe systems but will be active when the filling time has expired regardless until the pipe fill setpoint set in 29-05 Filled Setpoint is reached.

29-05 Filled Setpoint		
Range:		Function:
0 ProcessCtrlUnit*	[-999999.999 - 999999.999 ProcessCtrlUnit]	Specifies the filled setpoint at which the pipe fill function will be disabled and the PID controller will take control. This function can be used both for horizontal and vertical pipe systems.

29-06 No-Flow Disable Timer		
Range:		Function:
0 s*	[0 - 3600 s]	

3.24.3 29-1* Deragging Function

The purpose of the deragging feature is to free the pump blade of debris in waste water applications so that the pump operates normally.

A deragging event is defined as the time when the adjustable frequency drive starts to derag to when the deragging finishes. When a derag is started, the adjustable frequency drive ramps first to a stop and then an Off Delay expires before the first cycle begins.

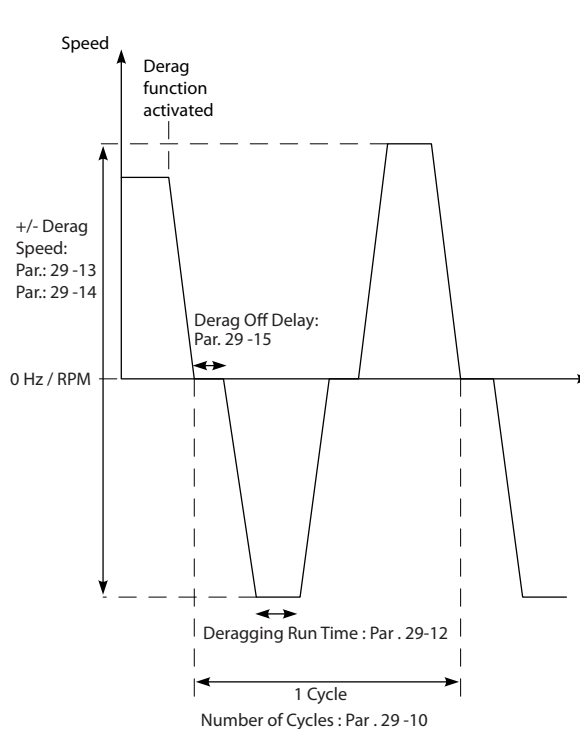

Figure 3.83 Derag Function

If a derag is triggered from a drive stopped state, the first Off Delay is skipped. The deragging event may consist of several cycles; one cycle consists of one pulse in the reverse direction followed by one pulse in the forward direction. Deragging is considered finished after the specified number of cycles has completed. More specifically, on the last pulse (it will always be forward) of the last cycle, the derag is considered finished after the Deragging Run Time expires (the adjustable frequency drive will be running at Derag Speed). In between pulses, the adjustable frequency drive output coasts for a specified Off Delay time to let debris in the pump settle.

NOTICE!

Do not enable deragging if the pump cannot operate in reverse direction.

There are three different notifications for an ongoing deragging event:

- Status in the LCP: "Auto Remote Derag"
- A bit in the Extended Status Word (Bit 23, 80 0000 hex)
- A digital output can be configured to reflect the active deragging status.

Depending on the application and on the purpose of using it, this feature can be used as preventative or reactive measure and can be triggered/started in the following different ways:

- On each Start Command (29-11 Derag at Start/ Stop)
- On each Stop Command (29-11 Derag at Start/ Stop)
- On each Start/Stop Command (29-11 Derag at Start/Stop)
- On Digital Input (parameter group 5-1*)
- On Drive Action with the Smart Logic Controller (13-52 SL Controller Action)
- As Timed Action (parameter group 23-**)
- On High Power (parameter group 29-2*)

29-10 Derag Cycles		
Range:	Function:	
Size related*	[0 - 10]	The number of cycles the adjustable frequency drive will derag.

29-11 Derag at Start/Stop		
Option:	Function:	
	Derag function when starting and stopping the adjustable frequency drive.	
[0]	Off	
[1]	Start	
[2]	Stop	
[3]	Start and stop	

29-12 Deragging Run Time		
Range:	Function:	
0 s*	[0 - 3600 s]	The time that the adjustable frequency drive will remain at the derag speed.

29-13 Derag Speed [RPM]		
Range:	Function:	
Size related*	[par. 4-11 - par. 4-13 RPM]	The speed at which the adjustable frequency drive will derag in RPM.

29-14 Derag Speed [Hz]		
Range:	Function:	
Size related*	[par. 4-12 - par. 4-14 Hz]	The speed at which the adjustable frequency drive will derag in Hertz.

29-15 Derag Off Delay		
Range:	Function:	
10 s*	[1 - 600 s]	The time that the adjustable frequency drive will remain off before starting another derag pulse. Allows contents of the pump to settle.

3.24.4 29-2* Derag Power Tuning

The derag feature monitors drive power in a similar fashion as no-flow. Based on two user-defined points and an offset value, the monitor calculates a derag power curve. It uses the exact same calculations as No-Flow with the difference being that derag monitors for high-power and not low-power.

Commissioning the No-Flow user points via the No-Flow, Auto Setup will also set the points of the derag curve to the same value.

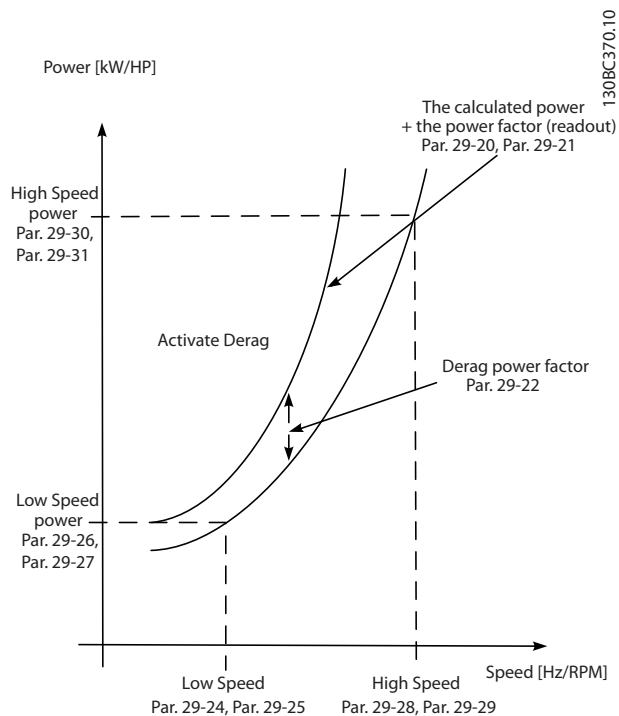

Figure 3.84 Derag Power Tuning

29-20 Derag Power[kW]		
Range:	Function:	
0 kW*	[0 - 0 kW]	Readout of calculated derag power at actual speed.

29-21 Derag Power[HP]		
Range:		Function:
0 hp*	[0 - 0 hp]	Readout of calculated derag power at actual speed.

29-22 Derag Power Factor		
Range:		Function:
200 %*	[1 - 400 %]	

29-23 Derag Power Delay		
Range:		Function:
601 s*	[1 - 601 s]	The time that the adjustable frequency drive must remain on reference and a high power condition for a derag to occur.

29-24 Low Speed [RPM]		
Range:		Function:
Size related*	[par. 4-11 - par. 29-28 RPM]	Set output speed used for registration of derag power at low speed in RPM.

29-25 Low Speed [Hz]		
Range:		Function:
Size related*	[par. 4-12 - par. 29-29 Hz]	Set output speed used for registration of derag power at low speed in Hz.

29-26 Low Speed Power [kW]		
Range:		Function:
Size related*	[0 - 0.00 kW]	Set derag power at low speed in kW.

29-27 Low Speed Power [HP]		
Range:		Function:
Size related*	[0 - 0.00 hp]	Set derag power at low speed in hp.

29-28 High Speed [RPM]		
Range:		Function:
Size related*	[par. 29-24 - par. 4-13 RPM]	Set output speed used for registration of derag power at high speed in RPM.

29-29 High Speed [Hz]		
Range:		Function:
Size related*	[par. 29-25 - par. 4-14 Hz]	Set output speed used for registration of derag power at high speed in Hz.

29-30 High Speed Power [kW]		
Range:		Function:
Size related*	[0 - 0.00 kW]	Set derag power at high speed in kW.

29-31 High Speed Power [HP]		
Range:		Function:
Size related*	[0 - 0.00 hp]	Set derag power at high speed in hp.

29-32 Derag On Ref Bandwidth		
Range:		Function:
5 %*	[1 - 100 %]	

29-33 Power Derag Limit		
Range:		Function:
3*	[0-10]	The number of times the power monitor can trigger consecutive derags before a fault is reported.

29-34 Consecutive Derag Interval		
Range:		Function:
Size related*	[Size related]	The time for an additional power derag to be considered "consecutive".

3.25 Parameters 30-** Special Features

3.25.1 30-8* Compatibility

30-81 Brake Resistor (ohm)		
Range:	Function:	
Size related*	[5 - 65535.00 Ohm]	Set the brake resistor value in Ohm with two decimals. This value is used for monitoring the power to the brake resistor in <i>2-13 Brake Power Monitoring</i> .

3.26 Parameters 31-** Bypass Option

Parameter group for the configuration of the electronically controlled bypass option board, MCO 104.

31-00 Bypass Mode		
Option:	Function:	
[0]	Drive	Select the operating mode of the bypass: <i>[0] Drive:</i> the motor is operated by the adjustable frequency drive.
[1]	Bypass	Select the operating mode of the bypass: <i>[1] Bypass:</i> motor can be run at full speed in bypass mode.

31-01 Bypass Start Time Delay		
Range:	Function:	
30 s*	[0 - 60 s]	Set the time delay within the time when the bypass receives a run command and the time when it starts the motor at full speed. A countdown timer will display time left.

31-02 Bypass Trip Time Delay		
Range:	Function:	
0 s*	[0 - 300 s]	Set the time delay from between the time that the drive experiences an alarm that stops it, and the time when the motor is automatically switched to bypass control. If the time delay is set to zero, a drive alarm will not automatically switch the motor to bypass control.

31-03 Test Mode Activation		
Option:	Function:	
[0]	Disabled	<i>[0] Disabled</i> means that the Test mode is disabled.
[1]	Enabled	<i>[1] Enabled</i> means that the motor runs in bypass, while the adjustable frequency drive can be tested in an open circuit. In this mode, the LCP will not control start/stop of the bypass.

31-10 Bypass Status Word		
Range:	Function:	
0 *	[0 - 65535]	Views the status of the bypass as a hexadecimal value.

31-11 Bypass Running Hours		
Range:	Function:	
0 h*	[0 - 2147483647 h]	Views the number of hours during which the motor has run in bypass mode. The counter can be reset in <i>15-07 Reset Running Hours Counter</i> . The value is saved when the adjustable frequency drive is turned off.

31-19 Remote Bypass Activation		
Option:	Function:	
[0]	Disabled	
[1]	Enabled	Feature: Unknown.

3.27 Parameters 35-** Sensor Input Option

3.27.1 35-0* Temp. Input Mode (MCB 114)

35-00 Term. X48/4 Temp. Unit		
Select the unit to be used with temperature input X48/4 settings and readouts:		
Option:	Function:	
[60]	°C	
[160]	°F	

35-01 Term. X48/4 Input Type		
View the temperature sensor type detected at input X48/4:		
Option:	Function:	
[0]	Not Connected	
[1]	PT100 2-wire	
[3]	PT1000 2-wire	
[5]	PT100 3-wire	
[7]	PT1000 3-wire	

35-02 Term. X48/7 Temp. Unit		
Select the unit to be used with temperature input X48/7 settings and readouts:		
Option:	Function:	
[60]	°C	
[160]	°F	

35-03 Term. X48/7 Input Type		
View the temperature sensor type detected at input X48/7:		
Option:	Function:	
[0]	Not Connected	
[1]	PT100 2-wire	
[3]	PT1000 2-wire	
[5]	PT100 3-wire	
[7]	PT1000 3-wire	

35-04 Term. X48/10 Temp. Unit		
Select the unit to be used with temperature input X48/10 settings and readouts:		
Option:	Function:	
[60]	°C	
[160]	°F	

35-05 Term. X48/10 Input Type		
View the temperature sensor type detected at input X48/10:		
Option:	Function:	
[0]	Not Connected	
[1]	PT100 2-wire	
[3]	PT1000 2-wire	
[5]	PT100 3-wire	
[7]	PT1000 3-wire	

35-06 Temperature Sensor Alarm Function		
Select the alarm function:		
Option:	Function:	
[0]	Off	
[2]	Stop	
[5]	Stop and trip	

3.27.2 35-1* Temp. Input X48/4 (MCB 114)

35-14 Term. X48/4 Filter Time Constant		
Range:	Function:	
0.001 s* [0.001 - 10 s]	Enter the filter time constant. This is a first-order digital low pass filter time constant for suppressing electrical noise in terminal X48/4. A high time constant value improves dampening but also increases the time delay through the filter.	

35-15 Term. X48/4 Temp. Monitor		
This parameter gives the possibility of enabling or disabling the temperature monitor for terminal X48/4. The temperature limits can be set in 35-16 Term. X48/4 Low Temp. Limit and 35-17 Term. X48/4 High Temp. Limit.		
Option:	Function:	
[0]	Disabled	
[1]	Enabled	

35-16 Term. X48/4 Low Temp. Limit		
Range:	Function:	
Size related*	[-50 - par. 35-17]	

35-17 Term. X48/4 High Temp. Limit		
Range:	Function:	
Size related*	[par. 35-16 - 204]	

3.27.3 35-2* Temp. Input X48/7 (MCB 114)

35-24 Term. X48/7 Filter Time Constant		
Range:	Function:	
0.001 s* [0.001 - 10 s]	Enter the filter time constant. This is a first-order digital low pass filter time constant for suppressing electrical noise in terminal X48/7. A high time constant value improves dampening but also increases the time delay through the filter.	

35-25 Term. X48/7 Temp. Monitor		
This parameter gives the possibility of enabling or disabling the temperature monitor for terminal X48/7. The temperature limits can be set in 35-26 Term. X48/7 Low Temp. Limit and 35-27 Term. X48/7 High Temp. Limit.		
Option:		Function:
[0]	Disabled	
[1]	Enabled	

35-26 Term. X48/7 Low Temp. Limit		
Range:		Function:
Size related*	[-50 - par. 35-27]	

35-27 Term. X48/7 High Temp. Limit		
Range:		Function:
Size related*	[par. 35-26 - 204]	

3.27.4 35-3* Temp. Input X48/10 (MCB 114)

35-34 Term. X48/10 Filter Time Constant		
Range:		Function:
0.001 s*	[0.001 - 10 s]	Enter the filter time constant. This is a first-order digital low pass filter time constant for suppressing electrical noise in terminal X48/10. A high time constant value improves dampening but also increases the time delay through the filter.

35-35 Term. X48/10 Temp. Monitor		
This parameter gives the possibility of enabling or disabling the temperature monitor for terminal X48/10. The temperature limits can be set in 35-36 Term. X48/10 Low Temp. Limit/35-37 Term. X48/10 High Temp. Limit.		
Option:		Function:
[0]	Disabled	
[1]	Enabled	

35-36 Term. X48/10 Low Temp. Limit		
Range:		Function:
Size related*	[-50 - par. 35-37]	

35-37 Term. X48/10 High Temp. Limit		
Range:		Function:
Size related*	[par. 35-36 - 204]	

3.27.5 35-4* Analog Input X48/2 (MCB 114)

35-42 Term. X48/2 Low Current		
Range:		Function:
4 mA*	[0 - par. 35-43 mA]	Enter the current (mA) that corresponds to the low reference value, set in 35-44 Term. X48/2 Low Ref./Feedb. Value. The value must be set at > 2mA in order to activate the Live Zero Timeout Function in 6-01 Live Zero Timeout Function.

35-43 Term. X48/2 High Current		
Range:		Function:
20 mA*	[par. 35-42 - 20 mA]	Enter the current (mA) that corresponds to the high reference value (set in 35-45 Term. X48/2 High Ref./Feedb. Value).

35-44 Term. X48/2 Low Ref./Feedb. Value		
Range:		Function:
0 *	[-999999.999 - 999999.999]	Enter the reference or feedback value (in RPM, Hz, bar, etc.) that corresponds to the voltage or current set in 35-42 Term. X48/2 Low Current.

35-45 Term. X48/2 High Ref./Feedb. Value		
Range:		Function:
100 *	[-999999.999 - 999999.999]	Enter the reference or feedback value (in RPM, Hz, bar, etc.) that corresponds to the voltage or current set in 35-43 Term. X48/2 High Current.

35-46 Term. X48/2 Filter Time Constant		
Range:		Function:
0.001 s*	[0.001 - 10 s]	Enter the filter time constant. This is a first-order digital low pass filter time constant for suppressing electrical noise in terminal X48/2. A high time constant value improves dampening but also increases the time delay through the filter.

4 Parameter Lists

4.1 Parameter Options

4.1.1 Default settings

Changes during operation:

“TRUE” means that the parameter can be changed while the adjustable frequency drive is in operation and “FALSE” means that the adjustable frequency drive must be stopped before a change can be made.

4 set-up:

'All set-up': the parameter can be set individually in each of the four set-ups, i.e. one single parameter can have four different data values.

'1 set-up': the data value will be the same in all set-ups.

SR:

Size related

N/A:

No default value available.

Conversion index:

This number refers to a conversion figure used when writing or reading by means of an adjustable frequency drive.

Conv. index	100	75	74	70	67	6	5	4	3	2	1	0	-1	-2	-3	-4	-5	-6
Conv. factor	1	3,600,000	3,600	60	1/60	1,000,000	100,000	10,000	1,000	100	10	1	0.1	0.01	0.001	0.0001	0.00001	0.000001

Table 4.1

Data type	Description	Type
2	Integer 8	Int8
3	Integer 16	Int16
4	Integer 32	Int32
5	Unsigned 8	UInt8
6	Unsigned 16	UInt16
7	Unsigned 32	UInt32
9	Visible String	VisStr
33	Normalized value 2 bytes	N2
35	Bit sequence of 16 Boolean variables	V2
54	Time difference w/o date	TimD

Table 4.2

4.1.2 Operation/Display 0-**

Par. No. #	Parameter description	Default value	4-set-up	Change during operation	Conversion index	Type
0-0* Basic Settings						
0-01	Language	[0] English	1 set-up	TRUE	-	Uint8
0-02	Motor Speed Unit	[0] RPM	2 set-ups	FALSE	-	Uint8
0-03	Regional Settings	[0] International	2 set-ups	FALSE	-	Uint8
0-04	Operating State at Power-up	[0] Resume	All set-ups	TRUE	-	Uint8
0-05	Local Mode Unit	[0] As Motor Speed Unit	2 set-ups	FALSE	-	Uint8
0-1* Set-up Operations						
0-10	Active Set-up	[1] Set-up 1	1 set-up	TRUE	-	Uint8
0-11	Programming Set-up	[9] Active Set-up	All set-ups	TRUE	-	Uint8
0-12	This Set-up Linked to	[0] Not linked	All set-ups	FALSE	-	Uint8
0-13	Readout: Linked Set-ups	0 N/A	All set-ups	FALSE	0	Uint16
0-14	Readout: Prog. Set-ups / Channel	0 N/A	All set-ups	TRUE	0	Int32
0-2* LCP Display						
0-20	Display Line 1.1 Small	1601	All set-ups	TRUE	-	Uint16
0-21	Display Line 1.2 Small	1662	All set-ups	TRUE	-	Uint16
0-22	Display Line 1.3 Small	1614	All set-ups	TRUE	-	Uint16
0-23	Display Line 2 Large	1613	All set-ups	TRUE	-	Uint16
0-24	Display Line 3 Large	1652	All set-ups	TRUE	-	Uint16
0-25	My Personal Menu	ExpressionLimit	1 set-up	TRUE	0	Uint16
0-3* LCP Cust. Readout						
0-30	Custom Readout Unit	[1] %	All set-ups	TRUE	-	Uint8
0-31	Custom Readout Min Value	ExpressionLimit	All set-ups	TRUE	-2	Int32
0-32	Custom Readout Max Value	100 CustomReadoutUnit	All set-ups	TRUE	-2	Int32
0-37	Display Text 1	0 N/A	1 set-up	TRUE	0	VisStr[25]
0-38	Display Text 2	0 N/A	1 set-up	TRUE	0	VisStr[25]
0-39	Display Text 3	0 N/A	1 set-up	TRUE	0	VisStr[25]
0-4* LCP Keypad						
0-40	[Hand on] Key on LCP	[1] Enabled	All set-ups	TRUE	-	Uint8
0-41	[Off] Key on LCP	[1] Enabled	All set-ups	TRUE	-	Uint8
0-42	[Auto on] Key on LCP	[1] Enabled	All set-ups	TRUE	-	Uint8
0-43	[Reset] Key on LCP	[1] Enabled	All set-ups	TRUE	-	Uint8
0-44	[Off/Reset] Key on LCP	[1] Enabled	All set-ups	TRUE	-	Uint8
0-45	[Drive Bypass] Key on LCP	[1] Enabled	All set-ups	TRUE	-	Uint8
0-5* Copy/Save						
0-50	LCP Copy	[0] No copy	All set-ups	FALSE	-	Uint8
0-51	Set-up Copy	[0] No copy	All set-ups	FALSE	-	Uint8
0-6* Password						
0-60	Main Menu Password	100 N/A	1 set-up	TRUE	0	Int16
0-61	Access to Main Menu w/o Password	[0] Full access	1 set-up	TRUE	-	Uint8
0-65	Personal Menu Password	200 N/A	1 set-up	TRUE	0	Uint16
0-66	Access to Personal Menu w/o Password	[0] Full access	1 set-up	TRUE	-	Uint8
0-67	Bus Password Access	0 N/A	All set-ups	TRUE	0	Uint16
0-7* Clock Settings						
0-70	Date and Time	ExpressionLimit	All set-ups	TRUE	0	TimeOfDay
0-71	Date Format	[0] YYYY-MM-DD	1 set-up	TRUE	-	Uint8
0-72	Time Format	[0] 24 h	1 set-up	TRUE	-	Uint8
0-74	DST/Summertime	[0] OFF	1 set-up	TRUE	-	Uint8
0-76	DST/Summertime Start	ExpressionLimit	1 set-up	TRUE	0	TimeOfDay
0-77	DST/Summertime End	ExpressionLimit	1 set-up	TRUE	0	TimeOfDay
0-79	Clock Fault	ExpressionLimit	1 set-up	TRUE	-	Uint8
0-81	Working Days	ExpressionLimit	1 set-up	TRUE	-	Uint8
0-82	Additional Working Days	ExpressionLimit	1 set-up	TRUE	0	TimeOfDay
0-83	Additional Non-Working Days	ExpressionLimit	1 set-up	TRUE	0	TimeOfDay
0-89	Date and Time Readout	0 N/A	All set-ups	TRUE	0	VisStr[25]

Table 4.3

4.1.3 Load/Motor 1-**

Par. No. #	Parameter description	Default value	4-set-up	Change during operation	Conversion index	Type
1-0* General Settings						
1-00	Configuration Mode	ExpressionLimit	All set-ups	TRUE	-	Uint8
1-01	Motor Control Principle	[1] VVC+	All set-ups	FALSE	-	Uint8
1-03	Torque Characteristics	[3] Auto Energy Optim. VT	All set-ups	TRUE	-	Uint8
1-06	Clockwise Direction	[0] Normal	All set-ups	FALSE	-	Uint8
1-1* Motor Selection						
1-10	Motor Construction	[0] Asynchron	All set-ups	FALSE	-	Uint8
1-1* VVC+ PM						
1-14	Damping Gain	120 %	All set-ups	TRUE	0	Int16
1-15	Low Speed Filter Time Const.	ExpressionLimit	All set-ups	TRUE	-2	Uint16
1-16	High Speed Filter Time Const.	ExpressionLimit	All set-ups	TRUE	-2	Uint16
1-17	Voltage filter time const.	ExpressionLimit	All set-ups	TRUE	-3	Uint16
1-2* Motor Data						
1-20	Motor Power [kW]	ExpressionLimit	All set-ups	FALSE	1	Uint32
1-21	Motor Power [HP]	ExpressionLimit	All set-ups	FALSE	-2	Uint32
1-22	Motor Voltage	ExpressionLimit	All set-ups	FALSE	0	Uint16
1-23	Motor Frequency	ExpressionLimit	All set-ups	FALSE	0	Uint16
1-24	Motor Current	ExpressionLimit	All set-ups	FALSE	-2	Uint32
1-25	Motor Nominal Speed	ExpressionLimit	All set-ups	FALSE	67	Uint16
1-26	Motor Cont. Rated Torque	ExpressionLimit	All set-ups	FALSE	-1	Uint32
1-28	Motor Rotation Check	[0] OFF	All set-ups	FALSE	-	Uint8
1-29	Automatic Motor Adaptation (AMA)	[0] Off	All set-ups	FALSE	-	Uint8
1-3* Addl. Motor Data						
1-30	Stator Resistance (Rs)	ExpressionLimit	All set-ups	FALSE	-4	Uint32
1-31	Rotor Resistance (Rr)	ExpressionLimit	All set-ups	FALSE	-4	Uint32
1-33	Stator Leakage Reactance (X1)	ExpressionLimit	All set-ups	FALSE	-4	Uint32
1-34	Rotor Leakage Reactance (X2)	ExpressionLimit	All set-ups	FALSE	-4	Uint32
1-35	Main Reactance (Xh)	ExpressionLimit	All set-ups	FALSE	-4	Uint32
1-36	Iron Loss Resistance (Rfe)	ExpressionLimit	All set-ups	FALSE	-3	Uint32
1-37	d-axis Inductance (Ld)	ExpressionLimit	All set-ups	FALSE	-6	Int32
1-39	Motor Poles	ExpressionLimit	All set-ups	FALSE	0	Uint8
1-40	Back EMF at 1000 RPM	ExpressionLimit	All set-ups	FALSE	0	Uint16
1-46	Position Detection Gain	100 %	All set-ups	TRUE	0	Uint16
1-5* Load-Indep. Setting						
1-50	Motor Magnetization at Zero Speed	100 %	All set-ups	TRUE	0	Uint16
1-51	Min Speed Normal Magnetizing [RPM]	ExpressionLimit	All set-ups	TRUE	67	Uint16
1-52	Min Speed Normal Magnetizing [Hz]	ExpressionLimit	All set-ups	TRUE	-1	Uint16
1-55	V/f Characteristic - V	ExpressionLimit	All set-ups	TRUE	-1	Uint16
1-56	V/f Characteristic - f	ExpressionLimit	All set-ups	TRUE	-1	Uint16
1-58	Flystart Test Pulses Current	ExpressionLimit	All set-ups	FALSE	0	Uint16
1-59	Flystart Test Pulses Frequency	ExpressionLimit	All set-ups	FALSE	0	Uint16
1-6* Load-Depend. Settg.						
1-60	Low Speed Load Compensation	100 %	All set-ups	TRUE	0	Int16
1-61	High Speed Load Compensation	100 %	All set-ups	TRUE	0	Int16
1-62	Slip Compensation	0 %	All set-ups	TRUE	0	Int16
1-63	Slip Compensation Time Constant	ExpressionLimit	All set-ups	TRUE	-2	Uint16
1-64	Resonance Dampening	100 %	All set-ups	TRUE	0	Uint16
1-65	Resonance Dampening Time Constant	5 ms	All set-ups	TRUE	-3	Uint8
1-66	Min. Current at Low Speed	ExpressionLimit	All set-ups	TRUE	0	Uint8
1-7* Start Adjustments						
1-70	PM Start Mode	[1] Parking	All set-ups	TRUE	-	Uint8
1-71	Start Delay	00 s	All set-ups	TRUE	-1	Uint16
1-72	Start Function	ExpressionLimit	All set-ups	TRUE	-	Uint8
1-73	Flying Start	ExpressionLimit	All set-ups	FALSE	-	Uint8
1-74	Start Speed [RPM]	ExpressionLimit	All set-ups	TRUE	67	Uint16
1-75	Start Speed [Hz]	ExpressionLimit	All set-ups	TRUE	-1	Uint16
1-76	Start Current	0 A	All set-ups	TRUE	-2	Uint32
1-8* Stop Adjustments						

Par. No. #	Parameter description	Default value	4-set-up	Change during operation	Conversion index	Type
1-80	Function at Stop	[0] Coast	All set-ups	TRUE	-	Uint8
1-81	Min Speed for Function at Stop [RPM]	ExpressionLimit	All set-ups	TRUE	67	Uint16
1-82	Min Speed for Function at Stop [Hz]	ExpressionLimit	All set-ups	TRUE	-1	Uint16
1-86	Trip Speed Low [RPM]	0 RPM	All set-ups	TRUE	67	Uint16
1-87	Trip Speed Low [Hz]	0 Hz	All set-ups	TRUE	-1	Uint16
1-9* Motor Temperature						
1-90	Motor Thermal Protection	ExpressionLimit	All set-ups	TRUE	-	Uint8
1-91	Motor External Fan	[0] No	All set-ups	TRUE	-	Uint16
1-93	Thermistor Source	[0] None	All set-ups	TRUE	-	Uint8

Table 4.4

4.1.4 Brakes 2-**

Par. No. #	Parameter description	Default value	4-set-up	Change during operation	Conversion index	Type
2-0* DC Brake						
2-00	DC Hold/Preheat Current	50 %	All set-ups	TRUE	0	Uint8
2-01	DC Brake Current	50 %	All set-ups	TRUE	0	Uint16
2-02	DC Braking Time	10 s	All set-ups	TRUE	-1	Uint16
2-03	DC Brake Cut-in Speed [RPM]	ExpressionLimit	All set-ups	TRUE	67	Uint16
2-04	DC Brake Cut-in Speed [Hz]	ExpressionLimit	All set-ups	TRUE	-1	Uint16
2-06	Parking Current	50 %	All set-ups	TRUE	0	Uint16
2-07	Parking Time	3 s	All set-ups	TRUE	-1	Uint16
2-1* Brake Energy Funct.						
2-10	Brake Function	ExpressionLimit	All set-ups	TRUE	-	Uint8
2-11	Brake Resistor (ohm)	ExpressionLimit	All set-ups	TRUE	0	Uint16
2-12	Brake Power Limit (kW)	ExpressionLimit	All set-ups	TRUE	0	Uint32
2-13	Brake Power Monitoring	[0] Off	All set-ups	TRUE	-	Uint8
2-15	Brake Check	[0] Off	All set-ups	TRUE	-	Uint8
2-16	AC Brake Max. Current	100 %	All set-ups	TRUE	-1	Uint32
2-17	Over-voltage Control	[2] Enabled	All set-ups	TRUE	-	Uint8

Table 4.5

4.1.5 Reference / Ramps 3-**

Par. No. #	Parameter description	Default value	4-set-up	Change during operation	Conversion index	Type
3-0* Reference Limits						
3-02	Minimum Reference	ExpressionLimit	All set-ups	TRUE	-3	Int32
3-03	Maximum Reference	ExpressionLimit	All set-ups	TRUE	-3	Int32
3-04	Reference Function	[0] Sum	All set-ups	TRUE	-	UInt8
3-1* References						
3-10	Preset Reference	0 %	All set-ups	TRUE	-2	Int16
3-11	Jog Speed [Hz]	ExpressionLimit	All set-ups	TRUE	-1	UInt16
3-13	Reference Site	[0] Linked to Hand / Auto	All set-ups	TRUE	-	UInt8
3-14	Preset Relative Reference	0 %	All set-ups	TRUE	-2	Int32
3-15	Reference 1 Source	[1] Analog Input 53	All set-ups	TRUE	-	UInt8
3-16	Reference 2 Source	[0] No function	All set-ups	TRUE	-	UInt8
3-17	Reference 3 Source	[0] No function	All set-ups	TRUE	-	UInt8
3-19	Jog Speed [RPM]	ExpressionLimit	All set-ups	TRUE	67	UInt16
3-4* Ramp 1						
3-41	Ramp 1 Ramp-up Time	ExpressionLimit	All set-ups	TRUE	-2	UInt32
3-42	Ramp 1 Ramp-down Time	ExpressionLimit	All set-ups	TRUE	-2	UInt32
3-5* Ramp 2						
3-51	Ramp 2 Ramp-up Time	ExpressionLimit	All set-ups	TRUE	-2	UInt32
3-52	Ramp 2 Ramp-down Time	ExpressionLimit	All set-ups	TRUE	-2	UInt32
3-8* Other Ramps						
3-80	Jog Ramp Time	ExpressionLimit	All set-ups	TRUE	-2	UInt32
3-81	Quick Stop Ramp Time	ExpressionLimit	2 set-ups	TRUE	-2	UInt32
3-84	Initial Ramp Time	0 s	All set-ups	TRUE	-2	UInt16
3-85	Check Valve Ramp Time	0 s	All set-ups	TRUE	-2	UInt16
3-86	Check Valve Ramp End Speed [RPM]	ExpressionLimit	All set-ups	TRUE	67	UInt16
3-87	Check Valve Ramp End Speed [HZ]	ExpressionLimit	All set-ups	TRUE	-1	UInt16
3-88	Final Ramp Time	0 s	All set-ups	TRUE	-2	UInt16
3-9* Digital Pot. meter						
3-90	Step Size	0.10 %	All set-ups	TRUE	-2	UInt16
3-91	Ramp Time	1 s	All set-ups	TRUE	-2	UInt32
3-92	Power Restore	[0] Off	All set-ups	TRUE	-	UInt8
3-93	Maximum Limit	100 %	All set-ups	TRUE	0	Int16
3-94	Minimum Limit	0 %	All set-ups	TRUE	0	Int16
3-95	Ramp Delay	ExpressionLimit	All set-ups	TRUE	-3	TimD

Table 4.6

4.1.6 Limits / Warnings 4-**

Par. No. #	Parameter description	Default value	4-set-up	Change during operation	Conversion index	Type
4-1* Motor Limits						
4-10	Motor Speed Direction	[0] Clockwise	All set-ups	FALSE	-	Uint8
4-11	Motor Speed Low Limit [RPM]	ExpressionLimit	All set-ups	TRUE	67	Uint16
4-12	Motor Speed Low Limit [Hz]	ExpressionLimit	All set-ups	TRUE	-1	Uint16
4-13	Motor Speed High Limit [RPM]	ExpressionLimit	All set-ups	TRUE	67	Uint16
4-14	Motor Speed High Limit [Hz]	ExpressionLimit	All set-ups	TRUE	-1	Uint16
4-16	Torque Limit Motor Mode	ExpressionLimit	All set-ups	TRUE	-1	Uint16
4-17	Torque Limit Generator Mode	100 %	All set-ups	TRUE	-1	Uint16
4-18	Current Limit	ExpressionLimit	All set-ups	TRUE	-1	Uint32
4-19	Max Output Frequency	ExpressionLimit	All set-ups	FALSE	-1	Uint16
4-5* Adj. Warnings						
4-50	Warning Current Low	0 A	All set-ups	TRUE	-2	Uint32
4-51	Warning Current High	I _{max} VLT (P1637)	All set-ups	TRUE	-2	Uint32
4-52	Warning Speed Low	0 RPM	All set-ups	TRUE	67	Uint16
4-53	Warning Speed High	outputSpeedHighLimit (P413)	All set-ups	TRUE	67	Uint16
4-54	Warning Reference Low	-999999.999 N/A	All set-ups	TRUE	-3	Int32
4-55	Warning Reference High	999999.999 N/A	All set-ups	TRUE	-3	Int32
4-56	Warning Feedback Low	-999999.999 ReferenceFeed-backUnit	All set-ups	TRUE	-3	Int32
4-57	Warning Feedback High	999999.999 ReferenceFeed-backUnit	All set-ups	TRUE	-3	Int32
4-58	Missing Motor Phase Function	ExpressionLimit	All set-ups	TRUE	-	Uint8
4-6* Speed Bypass						
4-60	Bypass Speed From [RPM]	ExpressionLimit	All set-ups	TRUE	67	Uint16
4-61	Bypass Speed From [Hz]	ExpressionLimit	All set-ups	TRUE	-1	Uint16
4-62	Bypass Speed to [RPM]	ExpressionLimit	All set-ups	TRUE	67	Uint16
4-63	Bypass Speed To [Hz]	ExpressionLimit	All set-ups	TRUE	-1	Uint16
4-64	Semi-Auto Bypass Set-up	[0] OFF	All set-ups	FALSE	-	Uint8

Table 4.7

4.1.7 Digital In/Out 5-**

Par. No. #	Parameter description	Default value	4-set-up	Change during operation	Conversion index	Type
5-0* Digital I/O mode						
5-00	Digital I/O Mode	[0] PNP - Active at 24 V	All set-ups	FALSE	-	Uint8
5-01	Terminal 27 Mode	[0] Input	All set-ups	TRUE	-	Uint8
5-02	Terminal 29 Mode	[0] Input	All set-ups	TRUE	-	Uint8
5-1* Digital Inputs						
5-10	Terminal 18 Digital Input	ExpressionLimit	All set-ups	TRUE	-	Uint8
5-11	Terminal 19 Digital Input	ExpressionLimit	All set-ups	TRUE	-	Uint8
5-12	Terminal 27 Digital Input	ExpressionLimit	All set-ups	TRUE	-	Uint8
5-13	Terminal 29 Digital Input	ExpressionLimit	All set-ups	TRUE	-	Uint8
5-14	Terminal 32 Digital Input	ExpressionLimit	All set-ups	TRUE	-	Uint8
5-15	Terminal 33 Digital Input	ExpressionLimit	All set-ups	TRUE	-	Uint8
5-16	Terminal X30/2 Digital Input	ExpressionLimit	All set-ups	TRUE	-	Uint8
5-17	Terminal X30/3 Digital Input	ExpressionLimit	All set-ups	TRUE	-	Uint8
5-18	Terminal X30/4 Digital Input	ExpressionLimit	All set-ups	TRUE	-	Uint8
5-19	Terminal 37 Digital Input	[1] Safe Stop Alarm	1 set-up	TRUE	-	Uint8
5-3* Digital Outputs						
5-30	Terminal 27 Digital Output	[0] No operation	All set-ups	TRUE	-	Uint8
5-31	Terminal 29 Digital Output	[0] No operation	All set-ups	TRUE	-	Uint8
5-32	Term X30/6 Digi Out (MCB 101)	[0] No operation	All set-ups	TRUE	-	Uint8
5-33	Term X30/7 Digi Out (MCB 101)	[0] No operation	All set-ups	TRUE	-	Uint8
5-4* Relays						
5-40	Function Relay	ExpressionLimit	All set-ups	TRUE	-	Uint8
5-41	On Delay, Relay	0.01 s	All set-ups	TRUE	-2	Uint16
5-42	Off Delay, Relay	0.01 s	All set-ups	TRUE	-2	Uint16
5-5* Pulse Input						
5-50	Term. 29 Low Frequency	100 Hz	All set-ups	TRUE	0	Uint32
5-51	Term. 29 High Frequency	100 Hz	All set-ups	TRUE	0	Uint32
5-52	Term. 29 Low Ref./Feedb. Value	0 N/A	All set-ups	TRUE	-3	Int32
5-53	Term. 29 High Ref./Feedb. Value	100 N/A	All set-ups	TRUE	-3	Int32
5-54	Pulse Filter Time Constant #29	100 ms	All set-ups	FALSE	-3	Uint16
5-55	Term. 33 Low Frequency	100 Hz	All set-ups	TRUE	0	Uint32
5-56	Term. 33 High Frequency	100 Hz	All set-ups	TRUE	0	Uint32
5-57	Term. 33 Low Ref./Feedb. Value	0 N/A	All set-ups	TRUE	-3	Int32
5-58	Term. 33 High Ref./Feedb. Value	100 N/A	All set-ups	TRUE	-3	Int32
5-59	Pulse Filter Time Constant #33	100 ms	All set-ups	FALSE	-3	Uint16
5-6* Pulse Output						
5-60	Terminal 27 Pulse Output Variable	[0] No operation	All set-ups	TRUE	-	Uint8
5-62	Pulse Output Max Freq #27	5000 Hz	All set-ups	TRUE	0	Uint32
5-63	Terminal 29 Pulse Output Variable	[0] No operation	All set-ups	TRUE	-	Uint8
5-65	Pulse Output Max Freq #29	5000 Hz	All set-ups	TRUE	0	Uint32
5-66	Terminal X30/6 Pulse Output Variable	[0] No operation	All set-ups	TRUE	-	Uint8
5-68	Pulse Output Max Freq #X30/6	5000 Hz	All set-ups	TRUE	0	Uint32
5-8* I/O Options						
5-80	AHF Cap Reconnect Delay	25 s	2 set-ups	TRUE	0	Uint16
5-9* Bus Controlled						
5-90	Digital & Relay Bus Control	0 N/A	All set-ups	TRUE	0	Uint32
5-93	Pulse Out #27 Bus Control	0 %	All set-ups	TRUE	-2	N2
5-94	Pulse Out #27 Timeout Preset	0 %	1 set-up	TRUE	-2	Uint16
5-95	Pulse Out #29 Bus Control	0 %	All set-ups	TRUE	-2	N2
5-96	Pulse Out #29 Timeout Preset	0 %	1 set-up	TRUE	-2	Uint16
5-97	Pulse Out #X30/6 Bus Control	0 %	All set-ups	TRUE	-2	N2
5-98	Pulse Out #X30/6 Timeout Preset	0 %	1 set-up	TRUE	-2	Uint16

Table 4.8

4.1.8 Analog In/Out 6-**

Par. No. #	Parameter description	Default value	4-set-up	Change during operation	Conversion index	Type
6-0* Analog I/O Mode						
6-00	Live Zero Timeout Time	10 s	All set-ups	TRUE	0	Uint8
6-01	Live Zero Timeout Function	[0] Off	All set-ups	TRUE	-	Uint8
6-1* Analog Input 53						
6-10	Terminal 53 Low Voltage	0.07 V	All set-ups	TRUE	-2	Int16
6-11	Terminal 53 High Voltage	10 V	All set-ups	TRUE	-2	Int16
6-12	Terminal 53 Low Current	4 mA	All set-ups	TRUE	-5	Int16
6-13	Terminal 53 High Current	20 mA	All set-ups	TRUE	-5	Int16
6-14	Terminal 53 Low Ref./Feedb. Value	0 N/A	All set-ups	TRUE	-3	Int32
6-15	Terminal 53 High Ref./Feedb. Value	ExpressionLimit	All set-ups	TRUE	-3	Int32
6-16	Terminal 53 Filter Time Constant	0.001 s	All set-ups	TRUE	-3	Uint16
6-17	Terminal 53 Live Zero	[1] Enabled	All set-ups	TRUE	-	Uint8
6-2* Analog Input 54						
6-20	Terminal 54 Low Voltage	0.07 V	All set-ups	TRUE	-2	Int16
6-21	Terminal 54 High Voltage	10 V	All set-ups	TRUE	-2	Int16
6-22	Terminal 54 Low Current	4 mA	All set-ups	TRUE	-5	Int16
6-23	Terminal 54 High Current	20 mA	All set-ups	TRUE	-5	Int16
6-24	Terminal 54 Low Ref./Feedb. Value	0 N/A	All set-ups	TRUE	-3	Int32
6-25	Terminal 54 High Ref./Feedb. Value	100 N/A	All set-ups	TRUE	-3	Int32
6-26	Terminal 54 Filter Time Constant	0.001 s	All set-ups	TRUE	-3	Uint16
6-27	Terminal 54 Live Zero	[1] Enabled	All set-ups	TRUE	-	Uint8
6-3* Analog Input X30/11						
6-30	Terminal X30/11 Low Voltage	0.07 V	All set-ups	TRUE	-2	Int16
6-31	Terminal X30/11 High Voltage	10 V	All set-ups	TRUE	-2	Int16
6-34	Term. X30/11 Low Ref./Feedb. Value	0 N/A	All set-ups	TRUE	-3	Int32
6-35	Term. X30/11 High Ref./Feedb. Value	100 N/A	All set-ups	TRUE	-3	Int32
6-36	Term. X30/11 Filter Time Constant	0.001 s	All set-ups	TRUE	-3	Uint16
6-37	Term. X30/11 Live Zero	[1] Enabled	All set-ups	TRUE	-	Uint8
6-4* Analog Input X30/12						
6-40	Terminal X30/12 Low Voltage	0.07 V	All set-ups	TRUE	-2	Int16
6-41	Terminal X30/12 High Voltage	10 V	All set-ups	TRUE	-2	Int16
6-44	Term. X30/12 Low Ref./Feedb. Value	0 N/A	All set-ups	TRUE	-3	Int32
6-45	Term. X30/12 High Ref./Feedb. Value	100 N/A	All set-ups	TRUE	-3	Int32
6-46	Term. X30/12 Filter Time Constant	0.001 s	All set-ups	TRUE	-3	Uint16
6-47	Term. X30/12 Live Zero	[1] Enabled	All set-ups	TRUE	-	Uint8
6-5* Analog Output 42						
6-50	Terminal 42 Output	[100] Output freq. 0-100	All set-ups	TRUE	-	Uint8
6-51	Terminal 42 Output Min Scale	0 %	All set-ups	TRUE	-2	Int16
6-52	Terminal 42 Output Max Scale	100 %	All set-ups	TRUE	-2	Int16
6-53	Terminal 42 Output Bus Control	0 %	All set-ups	TRUE	-2	N2
6-54	Terminal 42 Output Timeout Preset	0 %	1 set-up	TRUE	-2	Uint16
6-55	Terminal 42 Output Filter	[0] Off	1 set-up	TRUE	-	Uint8
6-6* Analog Output X30/8						
6-60	Terminal X30/8 Output	[0] No operation	All set-ups	TRUE	-	Uint8
6-61	Terminal X30/8 Min. Scale	0 %	All set-ups	TRUE	-2	Int16
6-62	Terminal X30/8 Max. Scale	100 %	All set-ups	TRUE	-2	Int16
6-63	Terminal X30/8 Output Bus Control	0 %	All set-ups	TRUE	-2	N2
6-64	Terminal X30/8 Output Timeout Preset	0 %	1 set-up	TRUE	-2	Uint16

Table 4.9

4.1.9 Comm. and Options 8-**

Par. No. #	Parameter description	Default value	4-set-up	Change during operation	Conversion index	Type
8-0* General Settings						
8-01	Control Site	ExpressionLimit	All set-ups	TRUE	-	Uint8
8-02	Control Source	ExpressionLimit	All set-ups	TRUE	-	Uint8
8-03	Control Timeout Time	ExpressionLimit	1 set-up	TRUE	-1	Uint32
8-04	Control Timeout Function	[0] Off	1 set-up	TRUE	-	Uint8
8-05	End-of-Timeout Function	[1] Resume set-up	1 set-up	TRUE	-	Uint8
8-06	Reset Control Timeout	[0] Do not reset	All set-ups	TRUE	-	Uint8
8-07	Diagnosis Trigger	[0] Disable	2 set-ups	TRUE	-	Uint8
8-08	Readout Filtering	ExpressionLimit	All set-ups	TRUE	-	Uint8
8-1* Control Settings						
8-10	Control Profile	[0] FC profile	All set-ups	TRUE	-	Uint8
8-13	Configurable Status Word STW	[1] Profile Default	All set-ups	TRUE	-	Uint8
8-14	Configurable Control Word CTW	[1] Profile default	All set-ups	TRUE	-	Uint8
8-3* FC Port Settings						
8-30	Protocol	[0] FC	1 set-up	TRUE	-	Uint8
8-31	Address	ExpressionLimit	1 set-up	TRUE	0	Uint8
8-32	Baud Rate	ExpressionLimit	1 set-up	TRUE	-	Uint8
8-33	Parity / Stop Bits	ExpressionLimit	1 set-up	TRUE	-	Uint8
8-35	Minimum Response Delay	ExpressionLimit	1 set-up	TRUE	-3	Uint16
8-36	Max Response Delay	ExpressionLimit	1 set-up	TRUE	-3	Uint16
8-37	Maximum Inter-Char Delay	ExpressionLimit	1 set-up	TRUE	-5	Uint16
8-4* FC MC protocol set						
8-40	Telegram selection	[1] Standard telegram 1	2 set-ups	TRUE	-	Uint8
8-42	PCD Write Configuration	ExpressionLimit	2 set-ups	TRUE	-	Uint16
8-43	PCD Read Configuration	ExpressionLimit	2 set-ups	TRUE	-	Uint16
8-5* Digital/Bus						
8-50	Coasting Select	[3] Logic OR	All set-ups	TRUE	-	Uint8
8-52	DC Brake Select	ExpressionLimit	All set-ups	TRUE	-	Uint8
8-53	Start Select	[3] Logic OR	All set-ups	TRUE	-	Uint8
8-54	Reverse Select	ExpressionLimit	All set-ups	TRUE	-	Uint8
8-55	Set-up Select	[3] Logic OR	All set-ups	TRUE	-	Uint8
8-56	Preset Reference Select	[3] Logic OR	All set-ups	TRUE	-	Uint8
8-7* BACnet						
8-70	BACnet Device Instance	1 N/A	1 set-up	TRUE	0	Uint32
8-72	MS/TP Max Masters	127 N/A	1 set-up	TRUE	0	Uint8
8-73	MS/TP Max Info Frames	1 N/A	1 set-up	TRUE	0	Uint16
8-74	"Startup I am"	[0] Send at power-up	1 set-up	TRUE	-	Uint8
8-75	Initialisation Password	ExpressionLimit	1 set-up	TRUE	0	VisStr[20]
8-8* FC Port Diagnostics						
8-80	Bus Message Count	0 N/A	All set-ups	TRUE	0	Uint32
8-81	Bus Error Count	0 N/A	All set-ups	TRUE	0	Uint32
8-82	Slave Message Rcvd	0 N/A	All set-ups	TRUE	0	Uint32
8-83	Slave Error Count	0 N/A	All set-ups	TRUE	0	Uint32
8-9* Bus Jog						
8-90	Bus Jog 1 Speed	100 RPM	All set-ups	TRUE	67	Uint16
8-91	Bus Jog 2 Speed	ExpressionLimit	All set-ups	TRUE	67	Uint16
8-94	Bus Feedback 1	0 N/A	1 set-up	TRUE	0	N2
8-95	Bus Feedback 2	0 N/A	1 set-up	TRUE	0	N2
8-96	Bus Feedback 3	0 N/A	1 set-up	TRUE	0	N2

Table 4.10

4.1.10 Profibus 9-**

4

Par. No. #	Parameter description	Default value	4-set-up	Change during operation	Conversion index	Type
9-00	Setpoint	0 N/A	All set-ups	TRUE	0	Uint16
9-07	Actual Value	0 N/A	All set-ups	FALSE	0	Uint16
9-15	PCD Write Configuration	ExpressionLimit	1 set-up	TRUE	-	Uint16
9-16	PCD Read Configuration	ExpressionLimit	2 set-ups	TRUE	-	Uint16
9-18	Node Address	126 N/A	1 set-up	TRUE	0	Uint8
9-22	Telegram Selection	[100] None	1 set-up	TRUE	-	Uint8
9-23	Parameters for Signals	0	All set-ups	TRUE	-	Uint16
9-27	Parameter Edit	[1] Enabled	2 set-ups	FALSE	-	Uint16
9-28	Process Control	[1] Enable cyclic master	2 set-ups	FALSE	-	Uint8
9-31	Safe Address	0 N/A	1 set-up	TRUE	0	Uint16
9-44	Fault Message Counter	0 N/A	All set-ups	TRUE	0	Uint16
9-45	Fault Code	0 N/A	All set-ups	TRUE	0	Uint16
9-47	Fault Number	0 N/A	All set-ups	TRUE	0	Uint16
9-52	Fault Situation Counter	0 N/A	All set-ups	TRUE	0	Uint16
9-53	Profibus Warning Word	0 N/A	All set-ups	TRUE	0	V2
9-63	Actual Baud Rate	[255] No Baud rate found	All set-ups	TRUE	-	Uint8
9-64	Device Identification	0 N/A	All set-ups	TRUE	0	Uint16
9-65	Profile Number	0 N/A	All set-ups	TRUE	0	OctStr[2]
9-67	Control Word 1	0 N/A	All set-ups	FALSE	0	V2
9-68	Status Word 1	0 N/A	All set-ups	TRUE	0	V2
9-71	Profibus Save Data Values	[0] Off	All set-ups	TRUE	-	Uint8
9-72	ProfibusDriveReset	[0] No action	1 set-up	FALSE	-	Uint8
9-75	DO Identification	0 N/A	All set-ups	TRUE	0	Uint16
9-80	Defined Parameters (1)	0 N/A	All set-ups	FALSE	0	Uint16
9-81	Defined Parameters (2)	0 N/A	All set-ups	FALSE	0	Uint16
9-82	Defined Parameters (3)	0 N/A	All set-ups	FALSE	0	Uint16
9-83	Defined Parameters (4)	0 N/A	All set-ups	FALSE	0	Uint16
9-84	Defined Parameters (5)	0 N/A	All set-ups	FALSE	0	Uint16
9-90	Changed Parameters (1)	0 N/A	All set-ups	FALSE	0	Uint16
9-91	Changed Parameters (2)	0 N/A	All set-ups	FALSE	0	Uint16
9-92	Changed Parameters (3)	0 N/A	All set-ups	FALSE	0	Uint16
9-93	Changed parameters (4)	0 N/A	All set-ups	FALSE	0	Uint16
9-94	Changed parameters (5)	0 N/A	All set-ups	FALSE	0	Uint16
9-99	Profibus Revision Counter	0 N/A	All set-ups	TRUE	0	Uint16

Table 4.11

4.1.11 CAN Fieldbus 10-**

Par. No. #	Parameter description	Default value	4-set-up	Change during operation	Conversion index	Type
10-0* Common Settings						
10-00	CAN Protocol	ExpressionLimit	2 set-ups	FALSE	-	Uint8
10-01	Baud Rate Select	ExpressionLimit	2 set-ups	TRUE	-	Uint8
10-02	MAC ID	ExpressionLimit	2 set-ups	TRUE	0	Uint8
10-05	Readout Transmit Error Counter	0 N/A	All set-ups	TRUE	0	Uint8
10-06	Readout Receive Error Counter	0 N/A	All set-ups	TRUE	0	Uint8
10-07	Readout Bus Off Counter	0 N/A	All set-ups	TRUE	0	Uint8
10-1* DeviceNet						
10-10	Process Data Type Selection	ExpressionLimit	All set-ups	TRUE	-	Uint8
10-11	Process Data Config Write	ExpressionLimit	2 set-ups	TRUE	-	Uint16
10-12	Process Data Config Read	ExpressionLimit	2 set-ups	TRUE	-	Uint16
10-13	Warning Parameter	0 N/A	All set-ups	TRUE	0	Uint16
10-14	Net Reference	[0] Off	2 set-ups	TRUE	-	Uint8
10-15	Net Control	[0] Off	2 set-ups	TRUE	-	Uint8
10-2* COS Filters						
10-20	COS Filter 1	0 N/A	All set-ups	FALSE	0	Uint16
10-21	COS Filter 2	0 N/A	All set-ups	FALSE	0	Uint16
10-22	COS Filter 3	0 N/A	All set-ups	FALSE	0	Uint16
10-23	COS Filter 4	0 N/A	All set-ups	FALSE	0	Uint16
10-3* Parameter Access						
10-30	Array Index	0 N/A	2 set-ups	TRUE	0	Uint8
10-31	Store Data Values	[0] Off	All set-ups	TRUE	-	Uint8
10-32	Devicenet Revision	ExpressionLimit	All set-ups	TRUE	0	Uint16
10-33	Store Always	[0] Off	1 set-up	TRUE	-	Uint8
10-34	DeviceNet Product Code	ExpressionLimit	1 set-up	TRUE	0	Uint16
10-39	Devicenet F Parameters	0 N/A	All set-ups	TRUE	0	Uint32

Table 4.12

4.1.12 Smart Logic 13-**

Par. No. #	Parameter description	Default value	4-set-up	Change during operation	Conversion index	Type
13-0* SLC Settings						
13-00	SL Controller Mode	ExpressionLimit	2 set-ups	TRUE	-	Uint8
13-01	Start Event	ExpressionLimit	2 set-ups	TRUE	-	Uint8
13-02	Stop Event	ExpressionLimit	2 set-ups	TRUE	-	Uint8
13-03	Reset SLC	[0] Do not reset SLC	All set-ups	TRUE	-	Uint8
13-1* Comparators						
13-10	Comparator Operand	ExpressionLimit	2 set-ups	TRUE	-	Uint8
13-11	Comparator Operator	ExpressionLimit	2 set-ups	TRUE	-	Uint8
13-12	Comparator Value	ExpressionLimit	2 set-ups	TRUE	-3	Int32
13-2* Timers						
13-20	SL Controller Timer	ExpressionLimit	1 set-up	TRUE	-3	TimD
13-4* Logic Rules						
13-40	Logic Rule Boolean 1	ExpressionLimit	2 set-ups	TRUE	-	Uint8
13-41	Logic Rule Operator 1	ExpressionLimit	2 set-ups	TRUE	-	Uint8
13-42	Logic Rule Boolean 2	ExpressionLimit	2 set-ups	TRUE	-	Uint8
13-43	Logic Rule Operator 2	ExpressionLimit	2 set-ups	TRUE	-	Uint8
13-44	Logic Rule Boolean 3	ExpressionLimit	2 set-ups	TRUE	-	Uint8
13-5* States						
13-51	SL Controller Event	ExpressionLimit	2 set-ups	TRUE	-	Uint8
13-52	SL Controller Action	ExpressionLimit	2 set-ups	TRUE	-	Uint8

Table 4.13

4.1.13 Special Functions 14-**

Par. No. #	Parameter description	Default value	4-set-up	Change during operation	Conversion index	Type
14-0* Inverter Switching						
14-00	Switching Pattern	ExpressionLimit	All set-ups	TRUE	-	Uint8
14-01	Switching Frequency	ExpressionLimit	All set-ups	TRUE	-	Uint8
14-03	Overmodulation	[1] On	All set-ups	FALSE	-	Uint8
14-04	PWM Random	[0] Off	All set-ups	TRUE	-	Uint8
14-1* Mains On/Off						
14-10	Mains Failure	[0] No function	All set-ups	FALSE	-	Uint8
14-11	Mains Voltage at Mains Fault	ExpressionLimit	All set-ups	TRUE	0	Uint16
14-12	Function at Mains Imbalance	[3] Derate	All set-ups	TRUE	-	Uint8
14-2* Reset Functions						
14-20	Reset Mode	[10] Automatic reset x 10	All set-ups	TRUE	-	Uint8
14-21	Automatic Restart Time	10 s	All set-ups	TRUE	0	Uint16
14-22	Operation Mode	[0] Normal operation	All set-ups	TRUE	-	Uint8
14-23	Typecode Setting	ExpressionLimit	2 set-ups	FALSE	-	Uint8
14-25	Trip Delay at Torque Limit	60 s	All set-ups	TRUE	0	Uint8
14-26	Trip Delay at Inverter Fault	ExpressionLimit	All set-ups	TRUE	0	Uint8
14-28	Production Settings	[0] No action	All set-ups	TRUE	-	Uint8
14-29	Service Code	0 N/A	All set-ups	TRUE	0	Int32
14-3* Current Limit Ctrl.						
14-30	Current Lim Ctrl, Proportional Gain	100 %	All set-ups	FALSE	0	Uint16
14-31	Current Lim Ctrl, Integration Time	ExpressionLimit	All set-ups	FALSE	-3	Uint16
14-32	Current Lim Ctrl, Filter Time	ExpressionLimit	All set-ups	FALSE	-4	Uint16
14-4* Energy Optimizing						
14-40	VT Level	66 %	All set-ups	FALSE	0	Uint8
14-41	AEO Minimum Magnetization	ExpressionLimit	All set-ups	TRUE	0	Uint8
14-42	Minimum AEO Frequency	10 Hz	All set-ups	TRUE	0	Uint8
14-43	Motor Cos-Phi	ExpressionLimit	All set-ups	TRUE	-2	Uint16
14-5* Environment						
14-50	RFI 1	[1] On	1 set-up	FALSE	-	Uint8
14-51	DC Link Compensation	[1] On	1 set-up	TRUE	-	Uint8
14-52	Fan Control	[0] Auto	All set-ups	TRUE	-	Uint8
14-53	Fan Monitor	[1] Warning	All set-ups	TRUE	-	Uint8
14-55	Output Filter	[0] No Filter	1 set-up	FALSE	-	Uint8
14-59	Actual Number of Inverter Units	ExpressionLimit	1 set-up	FALSE	0	Uint8
14-6* Auto Derate						
14-60	Function at Overtemperature	[1] Derate	All set-ups	TRUE	-	Uint8
14-61	Function at Inverter Overload	[1] Derate	All set-ups	TRUE	-	Uint8
14-62	Inv. Overload Derate Current	95 %	All set-ups	TRUE	0	Uint16
14-8* Options						
14-80	Option Supplied by External 24VDC	[0] No	2 set-ups	FALSE	-	Uint8
14-9* Fault Settings						
14-90	Fault Level	ExpressionLimit	1 set-up	TRUE	-	Uint8

Table 4.14

4.1.14 Adj. Freq. Drive Information 15-**

Par. No. #	Parameter description	Default value	4-set-up	Change during operation	Conversion index	Type
15-0* Operating Data						
15-00	Operating hours	0 h	All set-ups	FALSE	74	Uint32
15-01	Running Hours	0 h	All set-ups	FALSE	74	Uint32
15-02	kWh Counter	0 kWh	All set-ups	FALSE	75	Uint32
15-03	Power-ups	0 N/A	All set-ups	FALSE	0	Uint32
15-04	Over Temps	0 N/A	All set-ups	FALSE	0	Uint16

Par. No. #	Parameter description	Default value	4-set-up	Change during operation	Conversion index	Type
15-05	Over Volts	0 N/A	All set-ups	FALSE	0	Uint16
15-06	Reset kWh Counter	[0] Do not reset	All set-ups	TRUE	-	Uint8
15-07	Reset Running Hours Counter	[0] Do not reset	All set-ups	TRUE	-	Uint8
15-08	Number of Starts	0 N/A	All set-ups	FALSE	0	Uint32
15-1* Data Log Settings						
15-10	Logging Source	0	2 set-ups	TRUE	-	Uint16
15-11	Logging Interval	ExpressionLimit	2 set-ups	TRUE	-3	TimD
15-12	Trigger Event	[0] FALSE	1 set-up	TRUE	-	Uint8
15-13	Logging Mode	[0] Log always	2 set-ups	TRUE	-	Uint8
15-14	Samples Before Trigger	50 N/A	2 set-ups	TRUE	0	Uint8
15-2* Historic Log						
15-20	Historic Log: Event	0 N/A	All set-ups	FALSE	0	Uint8
15-21	Historic Log: Value	0 N/A	All set-ups	FALSE	0	Uint32
15-22	Historic Log: Time	0 ms	All set-ups	FALSE	-3	Uint32
15-23	Historic Log: Date and Time	ExpressionLimit	All set-ups	FALSE	0	TimeOfDay
15-3* Alarm Log						
15-30	Alarm Log: Error Code	0 N/A	All set-ups	FALSE	0	Uint16
15-31	Alarm Log: Value	0 N/A	All set-ups	FALSE	0	Int16
15-32	Alarm Log: Time	0 s	All set-ups	FALSE	0	Uint32
15-33	Alarm Log: Date and Time	ExpressionLimit	All set-ups	FALSE	0	TimeOfDay
15-34	Alarm Log: Setpoint	0 ProcessCtrlUnit	All set-ups	FALSE	-3	Int32
15-35	Alarm Log: Feedback	0 ProcessCtrlUnit	All set-ups	FALSE	-3	Int32
15-36	Alarm Log: Current Demand	0 %	All set-ups	FALSE	0	Uint8
15-37	Alarm Log: Process Ctrl Unit	[0] -	All set-ups	FALSE	-	Uint8
15-4* Drive Identification						
15-40	FC Type	0 N/A	All set-ups	FALSE	0	VisStr[6]
15-41	Power Section	0 N/A	All set-ups	FALSE	0	VisStr[20]
15-42	Voltage	0 N/A	All set-ups	FALSE	0	VisStr[20]
15-43	Software Version	0 N/A	All set-ups	FALSE	0	VisStr[5]
15-44	Ordered Typecode String	0 N/A	All set-ups	FALSE	0	VisStr[40]
15-45	Actual Typecode String	0 N/A	All set-ups	FALSE	0	VisStr[40]
15-46	Adj Freq Dr Ordering No.	0 N/A	All set-ups	FALSE	0	VisStr[8]
15-47	Power Card Ordering No.	0 N/A	All set-ups	FALSE	0	VisStr[8]
15-48	LCP ID Num.	0 N/A	All set-ups	FALSE	0	VisStr[20]
15-49	SW ID Control Card	0 N/A	All set-ups	FALSE	0	VisStr[20]
15-50	SW ID Power Card	0 N/A	All set-ups	FALSE	0	VisStr[20]
15-51	Adj Freq Dr Serial No.	0 N/A	All set-ups	FALSE	0	VisStr[10]
15-53	Power Card Serial Number	0 N/A	All set-ups	FALSE	0	VisStr[19]
15-59	CSIV Filename	ExpressionLimit	1 set-up	FALSE	0	VisStr[16]
15-6* Option Ident						
15-60	Option Mounted	0 N/A	All set-ups	FALSE	0	VisStr[30]
15-61	Option SW Version	0 N/A	All set-ups	FALSE	0	VisStr[20]
15-62	Option Ordering No	0 N/A	All set-ups	FALSE	0	VisStr[8]
15-63	Option Serial No	0 N/A	All set-ups	FALSE	0	VisStr[18]
15-70	Option in Slot A	0 N/A	All set-ups	FALSE	0	VisStr[30]
15-71	Slot A Option SW Version	0 N/A	All set-ups	FALSE	0	VisStr[20]
15-72	Option in Slot B	0 N/A	All set-ups	FALSE	0	VisStr[30]
15-73	Slot B Option SW Version	0 N/A	All set-ups	FALSE	0	VisStr[20]
15-74	Option in Slot C0	0 N/A	All set-ups	FALSE	0	VisStr[30]
15-75	Slot C0/E0 Option SW Version	0 N/A	All set-ups	FALSE	0	VisStr[20]
15-76	Option in Slot C1	0 N/A	All set-ups	FALSE	0	VisStr[30]
15-77	Slot C1/E1 Option SW Version	0 N/A	All set-ups	FALSE	0	VisStr[20]
15-9* Parameter Info						
15-92	Defined Parameters	0 N/A	All set-ups	FALSE	0	Uint16
15-93	Modified Parameters	0 N/A	All set-ups	FALSE	0	Uint16
15-98	Drive Identification	0 N/A	All set-ups	FALSE	0	VisStr[40]
15-99	Parameter Metadata	0 N/A	All set-ups	FALSE	0	Uint16

Table 4.15

4.1.15 Data Readouts 16-**

Par. No. #	Parameter description	Default value	4-set-up	Change during operation	Conversion index	Type
16-0* General Status						
16-00	Control Word	0 N/A	All set-ups	TRUE	0	V2
16-01	Reference [Unit]	0 ReferenceFeedbackUnit	All set-ups	TRUE	-3	Int32
16-02	Reference [%]	0 %	All set-ups	TRUE	-1	Int16
16-03	Status Word	0 N/A	All set-ups	TRUE	0	V2
16-05	Main Actual Value [%]	0 %	All set-ups	TRUE	-2	N2
16-09	Custom Readout	0 CustomReadoutUnit	All set-ups	TRUE	-2	Int32
16-1* Motor Status						
16-10	Power [kW]	0 kW	All set-ups	TRUE	1	Int32
16-11	Power [hp]	0 hp	All set-ups	TRUE	-2	Int32
16-12	Motor voltage	0 V	All set-ups	TRUE	-1	UInt16
16-13	Frequency	0 Hz	All set-ups	TRUE	-1	UInt16
16-14	Motor current	0 A	All set-ups	TRUE	-2	Int32
16-15	Frequency [%]	0 %	All set-ups	TRUE	-2	N2
16-16	Torque [Nm]	0 Nm	All set-ups	TRUE	-1	Int32
16-17	Speed [RPM]	0 RPM	All set-ups	TRUE	67	Int32
16-18	Motor Thermal	0 %	All set-ups	TRUE	0	UInt8
16-20	Motor Angle	0 N/A	All set-ups	TRUE	0	UInt16
16-22	Torque [%]	0 %	All set-ups	TRUE	0	Int16
16-3* Drive Status						
16-30	DC Link Voltage	0 V	All set-ups	TRUE	0	UInt16
16-32	Brake Energy /s	0 kW	All set-ups	TRUE	0	UInt32
16-33	Brake Energy /2 min	0 kW	All set-ups	TRUE	0	UInt32
16-34	Heatsink Temp.	0 °C	All set-ups	TRUE	100	UInt8
16-35	Inverter Thermal	0 %	All set-ups	TRUE	0	UInt8
16-36	Inv. Nom. Current	ExpressionLimit	All set-ups	TRUE	-2	UInt32
16-37	Inv. Max. Current	ExpressionLimit	All set-ups	TRUE	-2	UInt32
16-38	SL Controller State	0 N/A	All set-ups	TRUE	0	UInt8
16-39	Control Card Temp.	0 °C	All set-ups	TRUE	100	UInt8
16-40	Logging Buffer Full	[0] No	All set-ups	TRUE	-	UInt8
16-49	Current Fault Source	0 N/A	All set-ups	TRUE	0	UInt8
16-5* Ref. & Feedb.						
16-50	External Reference	0 N/A	All set-ups	TRUE	-1	Int16
16-52	Feedback [Unit]	0 ProcessCtrlUnit	All set-ups	TRUE	-3	Int32
16-53	Digi Pot Reference	0 N/A	All set-ups	TRUE	-2	Int16
16-54	Feedback 1 [Unit]	0 ProcessCtrlUnit	All set-ups	TRUE	-3	Int32
16-55	Feedback 2 [Unit]	0 ProcessCtrlUnit	All set-ups	TRUE	-3	Int32
16-56	Feedback 3 [Unit]	0 ProcessCtrlUnit	All set-ups	TRUE	-3	Int32
16-58	PID Output [%]	0 %	All set-ups	TRUE	-1	Int16
16-59	Adjusted Setpoint	0 ProcessCtrlUnit	All set-ups	TRUE	-3	Int32
16-6* Inputs & Outputs						
16-60	Digital Input	0 N/A	All set-ups	TRUE	0	UInt16
16-61	Terminal 53 Switch Setting	[0] Current	All set-ups	TRUE	-	UInt8
16-62	Analog Input 53	0 N/A	All set-ups	TRUE	-3	Int32
16-63	Terminal 54 Switch Setting	[0] Current	All set-ups	TRUE	-	UInt8
16-64	Analog Input 54	0 N/A	All set-ups	TRUE	-3	Int32
16-65	Analog Output 42 [mA]	0 N/A	All set-ups	TRUE	-3	Int16
16-66	Digital Output [bin]	0 N/A	All set-ups	TRUE	0	Int16
16-67	Pulse Input #29 [Hz]	0 N/A	All set-ups	TRUE	0	Int32
16-68	Pulse Input #33 [Hz]	0 N/A	All set-ups	TRUE	0	Int32
16-69	Pulse Output #27 [Hz]	0 N/A	All set-ups	TRUE	0	Int32
16-70	Pulse Output #29 [Hz]	0 N/A	All set-ups	TRUE	0	Int32
16-71	Relay Output [bin]	0 N/A	All set-ups	TRUE	0	UInt16
16-72	Counter A	0 N/A	All set-ups	TRUE	0	Int32
16-73	Counter B	0 N/A	All set-ups	TRUE	0	Int32
16-75	Analog In X30/11	0 N/A	All set-ups	TRUE	-3	Int32
16-76	Analog In X30/12	0 N/A	All set-ups	TRUE	-3	Int32

Par. No. #	Parameter description	Default value	4-set-up	Change during operation	Conversion index	Type
16-77	Analog Out X30/8 [mA]	0 N/A	All set-ups	TRUE	-3	Int16
16-8* Fieldbus & FC Port						
16-80	Fieldbus CTW 1	0 N/A	All set-ups	TRUE	0	V2
16-82	Fieldbus REF 1	0 N/A	All set-ups	TRUE	0	N2
16-84	Comm. Option Status	0 N/A	All set-ups	TRUE	0	V2
16-85	FC Port CTW 1	0 N/A	All set-ups	FALSE	0	V2
16-86	FC Port REF 1	0 N/A	All set-ups	FALSE	0	N2
16-9* Diagnosis Readouts						
16-90	Alarm Word	0 N/A	All set-ups	TRUE	0	UInt32
16-91	Alarm Word 2	0 N/A	All set-ups	TRUE	0	UInt32
16-92	Warning Word	0 N/A	All set-ups	TRUE	0	UInt32
16-93	Warning Word 2	0 N/A	All set-ups	TRUE	0	UInt32
16-94	Ext. Status Word	0 N/A	All set-ups	TRUE	0	UInt32
16-95	Ext. Status Word 2	0 N/A	All set-ups	TRUE	0	UInt32
16-96	Maintenance Word	0 N/A	All set-ups	TRUE	0	UInt32

Table 4.16

4.1.16 Data Readouts 2 18-**

Par. No. #	Parameter description	Default value	4-set-up	Change during operation	Conversion index	Type
18-0* Maintenance Log						
18-00	Maintenance Log: Item	0 N/A	All set-ups	FALSE	0	UInt8
18-01	Maintenance Log: Action	0 N/A	All set-ups	FALSE	0	UInt8
18-02	Maintenance Log: Time	0 s	All set-ups	FALSE	0	UInt32
18-03	Maintenance Log: Date and Time	ExpressionLimit	All set-ups	FALSE	0	TimeOf Day
18-3* Inputs & Outputs						
18-30	Analog Input X42/1	0 N/A	All set-ups	FALSE	-3	Int32
18-31	Analog Input X42/3	0 N/A	All set-ups	FALSE	-3	Int32
18-32	Analog Input X42/5	0 N/A	All set-ups	FALSE	-3	Int32
18-33	Analog Out X42/7 [V]	0 N/A	All set-ups	FALSE	-3	Int16
18-34	Analog Out X42/9 [V]	0 N/A	All set-ups	FALSE	-3	Int16
18-35	Analog Out X42/11 [V]	0 N/A	All set-ups	FALSE	-3	Int16
18-36	Analog Input X48/2 [mA]	0 N/A	All set-ups	TRUE	-3	Int32
18-37	Temp. Input X48/4	0 N/A	All set-ups	TRUE	0	Int16
18-38	Temp. Input X48/7	0 N/A	All set-ups	TRUE	0	Int16
18-39	Temp. Input X48/10	0 N/A	All set-ups	TRUE	0	Int16
18-6* Inputs & Outputs 2						
18-60	Digital Input 2	0 N/A	All set-ups	TRUE	0	UInt16

Table 4.17

4.1.17 Adj. Freq. Drive Closed-loop 20-**

Par. No. #	Parameter description	Default value	4-set-up	Change during operation	Conversion index	Type
20-0* Feedback						
20-00	Feedback 1 Source	[2] Analog Input 54	All set-ups	TRUE	-	Uint8
20-01	Feedback 1 Conversion	[0] Linear	All set-ups	FALSE	-	Uint8
20-02	Feedback 1 Source Unit	ExpressionLimit	All set-ups	TRUE	-	Uint8
20-03	Feedback 2 Source	[0] No function	All set-ups	TRUE	-	Uint8
20-04	Feedback 2 Conversion	[0] Linear	All set-ups	FALSE	-	Uint8
20-05	Feedback 2 Source Unit	ExpressionLimit	All set-ups	TRUE	-	Uint8
20-06	Feedback 3 Source	[0] No function	All set-ups	TRUE	-	Uint8
20-07	Feedback 3 Conversion	[0] Linear	All set-ups	FALSE	-	Uint8
20-08	Feedback 3 Source Unit	ExpressionLimit	All set-ups	TRUE	-	Uint8
20-12	Reference/Feedback Unit	ExpressionLimit	All set-ups	TRUE	-	Uint8
20-2* Feedback/Setpoint						
20-20	Feedback Function	[4] Maximum	All set-ups	TRUE	-	Uint8
20-21	Setpoint 1	0 ProcessCtrlUnit	All set-ups	TRUE	-3	Int32
20-22	Setpoint 2	0 ProcessCtrlUnit	All set-ups	TRUE	-3	Int32
20-23	Setpoint 3	0 ProcessCtrlUnit	All set-ups	TRUE	-3	Int32
20-7* PID Autotuning						
20-70	Closed-loop Type	[0] Auto	2 set-ups	TRUE	-	Uint8
20-71	PID Performance	[0] Normal	2 set-ups	TRUE	-	Uint8
20-72	PID Output Change	0.10 N/A	2 set-ups	TRUE	-2	Uint16
20-73	Minimum Feedback Level	-999999 ProcessCtrlUnit	2 set-ups	TRUE	-3	Int32
20-74	Maximum Feedback Level	999999 ProcessCtrlUnit	2 set-ups	TRUE	-3	Int32
20-79	PID Autotuning	[0] Disabled	All set-ups	TRUE	-	Uint8
20-8* PID Basic Settings						
20-81	PID Normal/ Inverse Control	[0] Normal	All set-ups	TRUE	-	Uint8
20-82	PID Start Speed [RPM]	ExpressionLimit	All set-ups	TRUE	67	Uint16
20-83	PID Start Speed [Hz]	ExpressionLimit	All set-ups	TRUE	-1	Uint16
20-84	On Reference Bandwidth	5 %	All set-ups	TRUE	0	Uint8
20-9* PID Controller						
20-91	PID Anti Windup	[1] On	All set-ups	TRUE	-	Uint8
20-93	PID Proportional Gain	2 N/A	All set-ups	TRUE	-2	Uint16
20-94	PID Integral Time	8 s	All set-ups	TRUE	-2	Uint32
20-95	PID Differentiation Time	0 s	All set-ups	TRUE	-2	Uint16
20-96	PID Diff. Gain Limit	5 N/A	All set-ups	TRUE	-1	Uint16

Table 4.18

4.1.18 Ext. Closed-loop 21-**

Par. No. #	Parameter description	Default value	4-set-up	Change during operation	Conversion index	Type
21-0* Ext. CL Autotuning						
21-00	Closed-loop Type	[0] Auto	2 set-ups	TRUE	-	Uint8
21-01	PID Performance	[0] Normal	2 set-ups	TRUE	-	Uint8
21-02	PID Output Change	0.10 N/A	2 set-ups	TRUE	-2	Uint16
21-03	Minimum Feedback Level	-999999 N/A	2 set-ups	TRUE	-3	Int32
21-04	Maximum Feedback Level	999999 N/A	2 set-ups	TRUE	-3	Int32
21-09	PID Auto Tuning	[0] Disabled	All set-ups	TRUE	-	Uint8
21-1* Ext. CL 1 Ref./Fb.						
21-10	Ext. 1 Ref./Feedback Unit	[0] -	All set-ups	TRUE	-	Uint8
21-11	Ext. 1 Minimum Reference	0 ExtPID1Unit	All set-ups	TRUE	-3	Int32
21-12	Ext. 1 Maximum Reference	100 ExtPID1Unit	All set-ups	TRUE	-3	Int32
21-13	Ext. 1 Reference Source	[0] No function	All set-ups	TRUE	-	Uint8
21-14	Ext. 1 Feedback Source	[0] No function	All set-ups	TRUE	-	Uint8
21-15	Ext. 1 Setpoint	0 ExtPID1Unit	All set-ups	TRUE	-3	Int32
21-17	Ext. 1 Reference [Unit]	0 ExtPID1Unit	All set-ups	TRUE	-3	Int32
21-18	Ext. 1 Feedback [Unit]	0 ExtPID1Unit	All set-ups	TRUE	-3	Int32
21-19	Ext. 1 Output [%]	0 %	All set-ups	TRUE	0	Int32
21-2* Ext. CL 1 PID						
21-20	Ext. 1 Normal/Inverse Control	[0] Normal	All set-ups	TRUE	-	Uint8
21-21	Ext. 1 Proportional Gain	0.50 N/A	All set-ups	TRUE	-2	Uint16
21-22	Ext. 1 Integral Time	20 s	All set-ups	TRUE	-2	Uint32
21-23	Ext. 1 Differentiation Time	0 s	All set-ups	TRUE	-2	Uint16
21-24	Ext. 1 Dif. Gain Limit	5 N/A	All set-ups	TRUE	-1	Uint16
21-3* Ext. CL 2 Ref./Fb.						
21-30	Ext. 2 Ref./Feedback Unit	[0] -	All set-ups	TRUE	-	Uint8
21-31	Ext. 2 Minimum Reference	0 ExtPID2Unit	All set-ups	TRUE	-3	Int32
21-32	Ext. 2 Maximum Reference	100 ExtPID2Unit	All set-ups	TRUE	-3	Int32
21-33	Ext. 2 Reference Source	[0] No function	All set-ups	TRUE	-	Uint8
21-34	Ext. 2 Feedback Source	[0] No function	All set-ups	TRUE	-	Uint8
21-35	Ext. 2 Setpoint	0 ExtPID2Unit	All set-ups	TRUE	-3	Int32
21-37	Ext. 2 Reference [Unit]	0 ExtPID2Unit	All set-ups	TRUE	-3	Int32
21-38	Ext. 2 Feedback [Unit]	0 ExtPID2Unit	All set-ups	TRUE	-3	Int32
21-39	Ext. 2 Output [%]	0 %	All set-ups	TRUE	0	Int32
21-4* Ext. CL 2 PID						
21-40	Ext. 2 Normal/Inverse Control	[0] Normal	All set-ups	TRUE	-	Uint8
21-41	Ext. 2 Proportional Gain	0.50 N/A	All set-ups	TRUE	-2	Uint16
21-42	Ext. 2 Integral Time	20 s	All set-ups	TRUE	-2	Uint32
21-43	Ext. 2 Differentiation Time	0 s	All set-ups	TRUE	-2	Uint16
21-44	Ext. 2 Dif. Gain Limit	5 N/A	All set-ups	TRUE	-1	Uint16
21-5* Ext. CL 3 Ref./Fb.						
21-50	Ext. 3 Ref./Feedback Unit	[0] -	All set-ups	TRUE	-	Uint8
21-51	Ext. 3 Minimum Reference	0 ExtPID3Unit	All set-ups	TRUE	-3	Int32
21-52	Ext. 3 Maximum Reference	100 ExtPID3Unit	All set-ups	TRUE	-3	Int32
21-53	Ext. 3 Reference Source	[0] No function	All set-ups	TRUE	-	Uint8
21-54	Ext. 3 Feedback Source	[0] No function	All set-ups	TRUE	-	Uint8
21-55	Ext. 3 Setpoint	0 ExtPID3Unit	All set-ups	TRUE	-3	Int32
21-57	Ext. 3 Reference [Unit]	0 ExtPID3Unit	All set-ups	TRUE	-3	Int32
21-58	Ext. 3 Feedback [Unit]	0 ExtPID3Unit	All set-ups	TRUE	-3	Int32
21-59	Ext. 3 Output [%]	0 %	All set-ups	TRUE	0	Int32
21-6* Ext. CL 3 PID						
21-60	Ext. 3 Normal/Inverse Control	[0] Normal	All set-ups	TRUE	-	Uint8
21-61	Ext. 3 Proportional Gain	0.50 N/A	All set-ups	TRUE	-2	Uint16
21-62	Ext. 3 Integral Time	20 s	All set-ups	TRUE	-2	Uint32
21-63	Ext. 3 Differentiation Time	0 s	All set-ups	TRUE	-2	Uint16
21-64	Ext. 3 Dif. Gain Limit	5 N/A	All set-ups	TRUE	-1	Uint16

Table 4.19

4.1.19 Application Functions 22-**

Par. No. #	Parameter description	Default value	4-set-up	Change during operation	Conversion index	Type
22-0* Miscellaneous						
22-00	External Interlock Delay	0 s	All set-ups	TRUE	0	Uint16
22-2* No-Flow Detection						
22-20	Low Power Auto Set-up	[0] OFF	All set-ups	FALSE	-	Uint8
22-21	Low Power Detection	[0] Disabled	All set-ups	TRUE	-	Uint8
22-22	Low Speed Detection	[0] Disabled	All set-ups	TRUE	-	Uint8
22-23	No-Flow Function	[0] OFF	All set-ups	TRUE	-	Uint8
22-24	No-Flow Delay	10 s	All set-ups	TRUE	0	Uint16
22-26	Dry Pump Function	[0] OFF	All set-ups	TRUE	-	Uint8
22-27	Dry Pump Delay	10 s	All set-ups	TRUE	0	Uint16
22-28	No-Flow Low Speed [RPM]	ExpressionLimit	All set-ups	TRUE	67	Uint16
22-29	No-Flow Low Speed [Hz]	ExpressionLimit	All set-ups	TRUE	-1	Uint16
22-3* No-Flow Power Tuning						
22-30	No-Flow Power	0 kW	All set-ups	TRUE	1	Uint32
22-31	Power Correction Factor	100 %	All set-ups	TRUE	0	Uint16
22-32	Low Speed [RPM]	ExpressionLimit	All set-ups	TRUE	67	Uint16
22-33	Low Speed [Hz]	ExpressionLimit	All set-ups	TRUE	-1	Uint16
22-34	Low Speed Power [kW]	ExpressionLimit	All set-ups	TRUE	1	Uint32
22-35	Low Speed Power [HP]	ExpressionLimit	All set-ups	TRUE	-2	Uint32
22-36	High Speed [RPM]	ExpressionLimit	All set-ups	TRUE	67	Uint16
22-37	High Speed [Hz]	ExpressionLimit	All set-ups	TRUE	-1	Uint16
22-38	High Speed Power [kW]	ExpressionLimit	All set-ups	TRUE	1	Uint32
22-39	High Speed Power [HP]	ExpressionLimit	All set-ups	TRUE	-2	Uint32
22-4* Sleep Mode						
22-40	Minimum Run Time	60 s	All set-ups	TRUE	0	Uint16
22-41	Minimum Sleep Time	30 s	All set-ups	TRUE	0	Uint16
22-42	Wake-up Speed [RPM]	ExpressionLimit	All set-ups	TRUE	67	Uint16
22-43	Wake-up Speed [Hz]	ExpressionLimit	All set-ups	TRUE	-1	Uint16
22-44	Wake-up Ref./FB Difference	10 %	All set-ups	TRUE	0	Int8
22-45	Setpoint Boost	0 %	All set-ups	TRUE	0	Int8
22-46	Maximum Boost Time	60 s	All set-ups	TRUE	0	Uint16
22-5* End of Curve						
22-50	End of Curve Function	[0] OFF	All set-ups	TRUE	-	Uint8
22-51	End of Curve Delay	10 s	All set-ups	TRUE	0	Uint16
22-6* Broken Belt Detection						
22-60	Broken Belt Function	[0] OFF	All set-ups	TRUE	-	Uint8
22-61	Broken Belt Torque	10 %	All set-ups	TRUE	0	Uint8
22-62	Broken Belt Delay	10 s	All set-ups	TRUE	0	Uint16
22-7* Short Cycle Protection						
22-75	Short Cycle Protection	[0] Disabled	All set-ups	TRUE	-	Uint8
22-76	Interval between Starts	start_to_start_min_on_time (P2277)	All set-ups	TRUE	0	Uint16
22-77	Minimum Run Time	0 s	All set-ups	TRUE	0	Uint16
22-78	Minimum Run Time Override	[0] Disabled	All set-ups	FALSE	-	Uint8
22-79	Minimum Run Time Override Value	0 ProcessCtrlUnit	All set-ups	TRUE	-3	Int32
22-8* Flow Compensation						
22-80	Flow Compensation	[0] Disabled	All set-ups	TRUE	-	Uint8
22-81	Square-linear Curve Approximation	100 %	All set-ups	TRUE	0	Uint8
22-82	Work Point Calculation	[0] Disabled	All set-ups	TRUE	-	Uint8
22-83	Speed at No-Flow [RPM]	ExpressionLimit	All set-ups	TRUE	67	Uint16
22-84	Speed at No-Flow [Hz]	ExpressionLimit	All set-ups	TRUE	-1	Uint16
22-85	Speed at Design Point [RPM]	ExpressionLimit	All set-ups	TRUE	67	Uint16
22-86	Speed at Design Point [Hz]	ExpressionLimit	All set-ups	TRUE	-1	Uint16
22-87	Pressure at No-Flow Speed	0 N/A	All set-ups	TRUE	-3	Int32
22-88	Pressure at Rated Speed	999999.999 N/A	All set-ups	TRUE	-3	Int32
22-89	Flow at Design Point	0 N/A	All set-ups	TRUE	-3	Int32
22-90	Flow at Rated Speed	0 N/A	All set-ups	TRUE	-3	Int32

Table 4.20

4.1.20 Timed Actions 23-**

Par. No. #	Parameter description	Default value	4-set-up	Change during operation	Conversion index	Type
23-0* Timed Actions						
23-00	ON Time	ExpressionLimit	2 set-ups	TRUE	0	TimeOfDay-WoDate
23-01	ON Action	[0] Disabled	2 set-ups	TRUE	-	UInt8
23-02	OFF Time	ExpressionLimit	2 set-ups	TRUE	0	TimeOfDay-WoDate
23-03	OFF Action	[0] Disabled	2 set-ups	TRUE	-	UInt8
23-04	Occurrence	[0] All days	2 set-ups	TRUE	-	UInt8
23-1* Maintenance						
23-10	Maintenance Item	[1] Motor bearings	1 set-up	TRUE	-	UInt8
23-11	Maintenance Action	[1] Lubricate	1 set-up	TRUE	-	UInt8
23-12	Maintenance Time Base	[0] Disabled	1 set-up	TRUE	-	UInt8
23-13	Maintenance Time Interval	1 h	1 set-up	TRUE	74	UInt32
23-14	Maintenance Date and Time	ExpressionLimit	1 set-up	TRUE	0	TimeOfDay
23-1* Maintenance Reset						
23-15	Reset Maintenance Word	[0] Do not reset	All set-ups	TRUE	-	UInt8
23-16	Maintenance Text	0 N/A	1 set-up	TRUE	0	VisStr[20]
23-5* Energy Log						
23-50	Energy Log Resolution	[5] Last 24 Hours	2 set-ups	TRUE	-	UInt8
23-51	Period Start	ExpressionLimit	2 set-ups	TRUE	0	TimeOfDay
23-53	Energy Log	0 N/A	All set-ups	TRUE	0	UInt32
23-54	Reset Energy Log	[0] Do not reset	All set-ups	TRUE	-	UInt8
23-6* Trending						
23-60	Trend Variable	[0] Power [kW]	2 set-ups	TRUE	-	UInt8
23-61	Continuous Bin Data	0 N/A	All set-ups	TRUE	0	UInt32
23-62	Timed Bin Data	0 N/A	All set-ups	TRUE	0	UInt32
23-63	Timed Period Start	ExpressionLimit	2 set-ups	TRUE	0	TimeOfDay
23-64	Timed Period Stop	ExpressionLimit	2 set-ups	TRUE	0	TimeOfDay
23-65	Minimum Bin Value	ExpressionLimit	2 set-ups	TRUE	0	UInt8
23-66	Reset Continuous Bin Data	[0] Do not reset	All set-ups	TRUE	-	UInt8
23-67	Reset Timed Bin Data	[0] Do not reset	All set-ups	TRUE	-	UInt8
23-8* Payback Counter						
23-80	Power Reference Factor	100 %	2 set-ups	TRUE	0	UInt8
23-81	Energy Cost	1 N/A	2 set-ups	TRUE	-2	UInt32
23-82	Investment	0 N/A	2 set-ups	TRUE	0	UInt32
23-83	Energy Savings	0 kWh	All set-ups	TRUE	75	Int32
23-84	Cost Savings	0 N/A	All set-ups	TRUE	0	Int32

Table 4.21

4.1.21 24-** Application Functions 2

Par. No. #	Parameter description	Default value	4-set-up	Change during operation	Conversion index	Type
24-1* Drive Bypass						
24-10	Drive Bypass Function	[0] Disabled	2 set-ups	TRUE	-	UInt8
24-11	Drive Bypass Delay Time	0 s	2 set-ups	TRUE	0	UInt16

Table 4.22

4.1.22 Cascade Controller 25-**

Par. No. #	Parameter description	Default value	4-set-up	Change during operation	Conversion index	Type
25-0* System Settings						
25-00	Cascade Controller	ExpressionLimit	2 set-ups	FALSE	-	Uint8
25-02	Motor Start	[0] Direct on Line	2 set-ups	FALSE	-	Uint8
25-04	Pump Cycling	ExpressionLimit	All set-ups	TRUE	-	Uint8
25-05	Fixed Lead Pump	ExpressionLimit	2 set-ups	FALSE	-	Uint8
25-06	Number Of Pumps	2 N/A	2 set-ups	FALSE	0	Uint8
25-2* Bandwidth Settings						
25-20	Staging Bandwidth	ExpressionLimit	All set-ups	TRUE	0	Uint8
25-21	Override Bandwidth	100 %	All set-ups	TRUE	0	Uint8
25-22	Fixed Speed Bandwidth	casco_staging_bandwidth (P2520)	All set-ups	TRUE	0	Uint8
25-23	SBW Staging Delay	15 s	All set-ups	TRUE	0	Uint16
25-24	SBW De-staging Delay	15 s	All set-ups	TRUE	0	Uint16
25-25	OBW Time	10 s	All set-ups	TRUE	0	Uint16
25-26	Destage At No-Flow	[0] Disabled	All set-ups	TRUE	-	Uint8
25-27	Stage Function	ExpressionLimit	All set-ups	TRUE	-	Uint8
25-28	Stage Function Time	15 s	All set-ups	TRUE	0	Uint16
25-29	Destage Function	ExpressionLimit	All set-ups	TRUE	-	Uint8
25-30	Destage Function Time	15 s	All set-ups	TRUE	0	Uint16
25-4* Staging Settings						
25-40	Ramp-down Delay	10 s	All set-ups	TRUE	-1	Uint16
25-41	Ramp-up Delay	2 s	All set-ups	TRUE	-1	Uint16
25-42	Staging Threshold	ExpressionLimit	All set-ups	TRUE	0	Uint8
25-43	De-staging Threshold	ExpressionLimit	All set-ups	TRUE	0	Uint8
25-44	Staging Speed [RPM]	0 RPM	All set-ups	TRUE	67	Uint16
25-45	Staging Speed [Hz]	0 Hz	All set-ups	TRUE	-1	Uint16
25-46	De-staging Speed [RPM]	0 RPM	All set-ups	TRUE	67	Uint16
25-47	De-staging Speed [Hz]	0 Hz	All set-ups	TRUE	-1	Uint16
25-5* Alternation Settings						
25-50	Lead Pump Alternation	ExpressionLimit	All set-ups	TRUE	-	Uint8
25-51	Alternation Event	[0] External	All set-ups	TRUE	-	Uint8
25-52	Alternation Time Interval	24 h	All set-ups	TRUE	74	Uint16
25-53	Alternation Timer Value	0 N/A	All set-ups	TRUE	0	VisStr[7]
25-54	Alternation Predefined Time	ExpressionLimit	All set-ups	TRUE	0	TimeOfDay-WoDate
25-55	Alternate if Load < 50%	[1] Enabled	All set-ups	TRUE	-	Uint8
25-56	Staging Mode at Alternation	[0] Slow	All set-ups	TRUE	-	Uint8
25-58	Run Next Pump Delay	0.1 s	All set-ups	TRUE	-1	Uint16
25-59	Run-on Line Delay	0.5 s	All set-ups	TRUE	-1	Uint16
25-8* Status						
25-80	Cascade Status	0 N/A	All set-ups	TRUE	0	VisStr[25]
25-81	Pump Status	0 N/A	All set-ups	TRUE	0	VisStr[25]
25-82	Lead Pump	0 N/A	All set-ups	TRUE	0	Uint8
25-83	Relay Status	0 N/A	All set-ups	TRUE	0	VisStr[4]
25-84	Pump ON Time	0 h	All set-ups	TRUE	74	Uint32
25-85	Relay ON Time	0 h	All set-ups	TRUE	74	Uint32
25-86	Reset Relay Counters	[0] Do not reset	All set-ups	TRUE	-	Uint8
25-9* Service						
25-90	Pump Interlock	[0] Off	All set-ups	TRUE	-	Uint8
25-91	Manual Alternation	0 N/A	All set-ups	TRUE	0	Uint8

Table 4.23

4.1.23 Analog I/O Option MCB 109 26-**

Par. No. #	Parameter description	Default value	4-set-up	Change during operation	Conversion index	Type
26-0* Analog I/O Mode						
26-00	Terminal X42/1 Mode	[1] Voltage	All set-ups	TRUE	-	Uint8
26-01	Terminal X42/3 Mode	[1] Voltage	All set-ups	TRUE	-	Uint8
26-02	Terminal X42/5 Mode	[1] Voltage	All set-ups	TRUE	-	Uint8
26-1* Analog Input X42/1						
26-10	Terminal X42/1 Low Voltage	0.07 V	All set-ups	TRUE	-2	Int16
26-11	Terminal X42/1 High Voltage	10 V	All set-ups	TRUE	-2	Int16
26-14	Term. X42/1 Low Ref./Feedb. Value	0 N/A	All set-ups	TRUE	-3	Int32
26-15	Term. X42/1 High Ref./Feedb. Value	100 N/A	All set-ups	TRUE	-3	Int32
26-16	Term. X42/1 Filter Time Constant	0.001 s	All set-ups	TRUE	-3	Uint16
26-17	Term. X42/1 Live Zero	[1] Enabled	All set-ups	TRUE	-	Uint8
26-2* Analog Input X42/3						
26-20	Terminal X42/3 Low Voltage	0.07 V	All set-ups	TRUE	-2	Int16
26-21	Terminal X42/3 High Voltage	10 V	All set-ups	TRUE	-2	Int16
26-24	Term. X42/3 Low Ref./Feedb. Value	0 N/A	All set-ups	TRUE	-3	Int32
26-25	Term. X42/3 High Ref./Feedb. Value	100 N/A	All set-ups	TRUE	-3	Int32
26-26	Term. X42/3 Filter Time Constant	0.001 s	All set-ups	TRUE	-3	Uint16
26-27	Term. X42/3 Live Zero	[1] Enabled	All set-ups	TRUE	-	Uint8
26-3* Analog Input X42/5						
26-30	Terminal X42/5 Low Voltage	0.07 V	All set-ups	TRUE	-2	Int16
26-31	Terminal X42/5 High Voltage	10 V	All set-ups	TRUE	-2	Int16
26-34	Term. X42/5 Low Ref./Feedb. Value	0 N/A	All set-ups	TRUE	-3	Int32
26-35	Term. X42/5 High Ref./Feedb. Value	100 N/A	All set-ups	TRUE	-3	Int32
26-36	Term. X42/5 Filter Time Constant	0.001 s	All set-ups	TRUE	-3	Uint16
26-37	Term. X42/5 Live Zero	[1] Enabled	All set-ups	TRUE	-	Uint8
26-4* Analog Out X42/7						
26-40	Terminal X42/7 Output	[0] No operation	All set-ups	TRUE	-	Uint8
26-41	Terminal X42/7 Min. Scale	0 %	All set-ups	TRUE	-2	Int16
26-42	Terminal X42/7 Max. Scale	100 %	All set-ups	TRUE	-2	Int16
26-43	Terminal X42/7 Bus Control	0 %	All set-ups	TRUE	-2	N2
26-44	Terminal X42/7 Timeout Preset	0 %	1 set-up	TRUE	-2	Uint16
26-5* Analog Out X42/9						
26-50	Terminal X42/9 Output	[0] No operation	All set-ups	TRUE	-	Uint8
26-51	Terminal X42/9 Min. Scale	0 %	All set-ups	TRUE	-2	Int16
26-52	Terminal X42/9 Max. Scale	100 %	All set-ups	TRUE	-2	Int16
26-53	Terminal X42/9 Bus Control	0 %	All set-ups	TRUE	-2	N2
26-54	Terminal X42/9 Timeout Preset	0 %	1 set-up	TRUE	-2	Uint16
26-6* Analog Out X42/11						
26-60	Terminal X42/11 Output	[0] No operation	All set-ups	TRUE	-	Uint8
26-61	Terminal X42/11 Min. Scale	0 %	All set-ups	TRUE	-2	Int16
26-62	Terminal X42/11 Max. Scale	100 %	All set-ups	TRUE	-2	Int16
26-63	Terminal X42/11 Bus Control	0 %	All set-ups	TRUE	-2	N2
26-64	Terminal X42/11 Timeout Preset	0 %	1 set-up	TRUE	-2	Uint16

Table 4.24

4.1.24 Cascade CTL Option 27-**

Par. No. #	Parameter description	Default value	4-set-up	Change during operation	Conversion index	Type
27-0* Control & Status						
27-01	Pump Status	[0] Ready	All set-ups	TRUE	-	Uint8
27-02	Manual Pump Control	[0] No Operation	2 set-ups	TRUE	-	Uint8
27-03	Current Runtime Hours	0 h	All set-ups	TRUE	74	Uint32
27-04	Pump Total Lifetime Hours	0 h	All set-ups	TRUE	74	Uint32
27-1* Configuration						

Par. No. #	Parameter description	Default value	4-set-up	Change during operation	Conversion index	Type
27-10	Cascade Controller	ExpressionLimit	2 set-ups	FALSE	-	UInt8
27-11	Number Of Drives	ExpressionLimit	2 set-ups	FALSE	0	UInt8
27-12	Number Of Pumps	ExpressionLimit	2 set-ups	FALSE	0	UInt8
27-14	Pump Capacity	100 %	2 set-ups	FALSE	0	UInt16
27-16	Runtime Balancing	[0] Balanced Priority 1	2 set-ups	TRUE	-	UInt8
27-17	Motor Starters	[0] Direct Online	2 set-ups	FALSE	-	UInt8
27-18	Spin Time for Unused Pumps	ExpressionLimit	All set-ups	TRUE	0	UInt16
27-19	Reset Current Runtime Hours	[0] Do not reset	All set-ups	TRUE	-	UInt8
27-2* Bandwidth Settings						
27-20	Normal Operating Range	ExpressionLimit	All set-ups	TRUE	0	UInt8
27-21	Override Limit	100 %	All set-ups	TRUE	0	UInt8
27-22	Fixed Speed Only Operating Range	ExpressionLimit	All set-ups	TRUE	0	UInt8
27-23	Staging Delay	15 s	All set-ups	TRUE	0	UInt16
27-24	Destaging Delay	15 s	All set-ups	TRUE	0	UInt16
27-25	Override Hold Time	10 s	All set-ups	TRUE	0	UInt16
27-27	Min Speed Destage Delay	ExpressionLimit	All set-ups	TRUE	0	UInt16
27-3* Staging Speed						
27-30	Auto Tune Staging Speeds	[1] Enabled	All set-ups	TRUE	-	UInt8
27-31	Stage On Speed [RPM]	ExpressionLimit	All set-ups	TRUE	67	UInt16
27-32	Stage On Speed [Hz]	ExpressionLimit	All set-ups	TRUE	-1	UInt16
27-33	Stage Off Speed [RPM]	ExpressionLimit	All set-ups	TRUE	67	UInt16
27-34	Stage Off Speed [Hz]	ExpressionLimit	All set-ups	TRUE	-1	UInt16
27-4* Staging Settings						
27-40	Auto Tune Staging Settings	[0] Disabled	All set-ups	TRUE	-	UInt8
27-41	Ramp Down Delay	10 s	All set-ups	TRUE	-1	UInt16
27-42	Ramp Up Delay	2 s	All set-ups	TRUE	-1	UInt16
27-43	Staging Threshold	ExpressionLimit	All set-ups	TRUE	0	UInt8
27-44	Destaging Threshold	ExpressionLimit	All set-ups	TRUE	0	UInt8
27-45	Staging Speed [RPM]	0 RPM	All set-ups	TRUE	67	UInt16
27-46	Staging Speed [Hz]	0 Hz	All set-ups	TRUE	-1	UInt16
27-47	Destaging Speed [RPM]	0 RPM	All set-ups	TRUE	67	UInt16
27-48	Destaging Speed [Hz]	0 Hz	All set-ups	TRUE	-1	UInt16
27-5* Alternate Settings						
27-50	Automatic Alternation	[0] Disabled	All set-ups	FALSE	-	UInt8
27-51	Alternation Event	ExpressionLimit	All set-ups	TRUE	-	UInt8
27-52	Alternation Time Interval	0 min	All set-ups	TRUE	70	UInt16
27-53	Alternation Timer Value	0 min	All set-ups	TRUE	70	UInt16
27-54	Alternation At Time of Day	[0] Disabled	All set-ups	TRUE	-	UInt8
27-55	Alternation Predefined Time	ExpressionLimit	All set-ups	TRUE	0	TimeOfDay-WoDate
27-56	Alternate Capacity is <	0 %	All set-ups	TRUE	0	UInt8
27-58	Run Next Pump Delay	0.1 s	All set-ups	TRUE	-1	UInt16
27-6* Digital Inputs						
27-60	Terminal X66/1 Digital Input	[0] No operation	All set-ups	TRUE	-	UInt8
27-61	Terminal X66/3 Digital Input	[0] No operation	All set-ups	TRUE	-	UInt8
27-62	Terminal X66/5 Digital Input	[0] No operation	All set-ups	TRUE	-	UInt8
27-63	Terminal X66/7 Digital Input	[0] No operation	All set-ups	TRUE	-	UInt8
27-64	Terminal X66/9 Digital Input	[0] No operation	All set-ups	TRUE	-	UInt8
27-65	Terminal X66/11 Digital Input	[0] No operation	All set-ups	TRUE	-	UInt8
27-66	Terminal X66/13 Digital Input	[0] No operation	All set-ups	TRUE	-	UInt8
27-7* Connections						
27-70	Relay	[0] Standard Relay	2 set-ups	FALSE	-	UInt8
27-9* Readouts						
27-91	Cascade Reference	0 %	All set-ups	TRUE	-1	Int16
27-92	% Of Total Capacity	0 %	All set-ups	TRUE	0	UInt16
27-93	Cascade Option Status	[0] Disabled	All set-ups	TRUE	-	UInt8
27-94	Cascade System Status	0 N/A	All set-ups	TRUE	0	VisStr[25]
27-95	Advanced Cascade Relay Output [bin]	0 N/A	All set-ups	TRUE	0	UInt16

Par. No. #	Parameter description	Default value	4-set-up	Change during operation	Conversion index	Type
27-96	Extended Cascade Relay Output [bin]	0 N/A	All set-ups	TRUE	0	Uint16

Table 4.25

4.1.25 Water Application Functions 29-**

Par. No. #	Parameter description	Default value	4-set-up	Change during operation	Conversion index	Type
29-0* Pipe Fill						
29-00	Pipe Fill Enable	[0] Disabled	2 set-ups	FALSE	-	Uint8
29-01	Pipe Fill Speed [RPM]	ExpressionLimit	All set-ups	TRUE	67	Uint16
29-02	Pipe Fill Speed [Hz]	ExpressionLimit	All set-ups	TRUE	-1	Uint16
29-03	Pipe Fill Time	0 s	All set-ups	TRUE	-2	Uint32
29-04	Pipe Fill Rate	0.001 ProcessCtrlUnit	All set-ups	TRUE	-3	Int32
29-05	Filled Setpoint	0 ProcessCtrlUnit	All set-ups	TRUE	-3	Int32
29-06	No-Flow Disable Timer	0 s	All set-ups	TRUE	-2	Uint16
29-1* Deragging Function						
29-10	Derag Cycles	ExpressionLimit	2 set-ups	FALSE	0	Uint32
29-11	Derag at Start/Stop	[0] Off	1 set-up	TRUE	-	Uint8
29-12	Deragging Run Time	0 s	All set-ups	TRUE	0	Uint16
29-13	Derag Speed [RPM]	ExpressionLimit	All set-ups	TRUE	67	Uint16
29-14	Derag Speed [Hz]	ExpressionLimit	All set-ups	TRUE	-1	Uint16
29-15	Derag Off Delay	10 s	All set-ups	TRUE	0	Uint16
29-2* Derag Power Tuning						
29-20	Derag Power[kW]	0 kW	All set-ups	TRUE	1	Uint32
29-21	Derag Power[HP]	0 hp	All set-ups	TRUE	-2	Uint32
29-22	Derag Power Factor	200 %	All set-ups	TRUE	0	Uint16
29-23	Derag Power Delay	601 s	All set-ups	TRUE	0	Uint16
29-24	Low Speed [RPM]	ExpressionLimit	All set-ups	TRUE	67	Uint16
29-25	Low Speed [Hz]	ExpressionLimit	All set-ups	TRUE	-1	Uint16
29-26	Low Speed Power [kW]	ExpressionLimit	All set-ups	TRUE	1	Uint32
29-27	Low Speed Power [HP]	ExpressionLimit	All set-ups	TRUE	-2	Uint32
29-28	High Speed [RPM]	ExpressionLimit	All set-ups	TRUE	67	Uint16
29-29	High Speed [Hz]	ExpressionLimit	All set-ups	TRUE	-1	Uint16
29-30	High Speed Power [kW]	ExpressionLimit	All set-ups	TRUE	1	Uint32
29-31	High Speed Power [HP]	ExpressionLimit	All set-ups	TRUE	-2	Uint32
29-32	Derag On Ref Bandwidth	5 %	All set-ups	TRUE	0	Uint8
29-33	Power Derag Limit	3 N/A	2 set-ups	FALSE	0	Uint8
29-34	Consecutive Derag Interval	ExpressionLimit	All set-ups	FALSE	0	Uint16

Table 4.26

4.1.26 Special Features 30-**

Par. No. #	Parameter description	Default value	4-set-up	Change during operation	Conversion index	Type
30-8* Compatibility (I)						
30-81	Brake Resistor (ohm)	ExpressionLimit	All set-ups	TRUE	-2	Uint32

Table 4.27

4.1.27 Bypass Option 31-**

Par. No. #	Parameter description	Default value	4-set-up	Change during operation	Conversion index	Type
31-00	Bypass Mode	[0] Drive	All set-ups	TRUE	-	Uint8
31-01	Bypass Start Time Delay	30 s	All set-ups	TRUE	0	Uint16
31-02	Bypass Trip Time Delay	0 s	All set-ups	TRUE	0	Uint16
31-03	Test Mode Activation	[0] Disabled	All set-ups	TRUE	-	Uint8
31-10	Bypass Status Word	0 N/A	All set-ups	FALSE	0	V2
31-11	Bypass Running Hours	0 h	All set-ups	FALSE	74	Uint32
31-19	Remote Bypass Activation	[0] Disabled	2 set-ups	TRUE	-	Uint8

Table 4.28

4.1.28 Sensor Input Option 35-**

Par. No. #	Parameter description	Default value	4-set-up	Change during operation	Conversion index	Type
35-0* Temp. Input Mode						
35-00	Term. X48/4 Temp. Unit	[60] °C	All set-ups	TRUE	-	Uint8
35-01	Term. X48/4 Input Type	[0] Not Connected	All set-ups	TRUE	-	Uint8
35-02	Term. X48/7 Temp. Unit	[60] °C	All set-ups	TRUE	-	Uint8
35-03	Term. X48/7 Input Type	[0] Not Connected	All set-ups	TRUE	-	Uint8
35-04	Term. X48/10 Temp. Unit	[60] °C	All set-ups	TRUE	-	Uint8
35-05	Term. X48/10 Input Type	[0] Not Connected	All set-ups	TRUE	-	Uint8
35-06	Temperature Sensor Alarm Function	[5] Stop and trip	All set-ups	TRUE	-	Uint8
35-1* Temp. Input X48/4						
35-14	Term. X48/4 Filter Time Constant	0.001 s	All set-ups	TRUE	-3	Uint16
35-15	Term. X48/4 Temp. Monitor	[0] Disabled	All set-ups	TRUE	-	Uint8
35-16	Term. X48/4 Low Temp. Limit	ExpressionLimit	All set-ups	TRUE	0	Int16
35-17	Term. X48/4 High Temp. Limit	ExpressionLimit	All set-ups	TRUE	0	Int16
35-2* Temp. Input X48/7						
35-24	Term. X48/7 Filter Time Constant	0.001 s	All set-ups	TRUE	-3	Uint16
35-25	Term. X48/7 Temp. Monitor	[0] Disabled	All set-ups	TRUE	-	Uint8
35-26	Term. X48/7 Low Temp. Limit	ExpressionLimit	All set-ups	TRUE	0	Int16
35-27	Term. X48/7 High Temp. Limit	ExpressionLimit	All set-ups	TRUE	0	Int16
35-3* Temp. Input X48/10						
35-34	Term. X48/10 Filter Time Constant	0.001 s	All set-ups	TRUE	-3	Uint16
35-35	Term. X48/10 Temp. Monitor	[0] Disabled	All set-ups	TRUE	-	Uint8
35-36	Term. X48/10 Low Temp. Limit	ExpressionLimit	All set-ups	TRUE	0	Int16
35-37	Term. X48/10 High Temp. Limit	ExpressionLimit	All set-ups	TRUE	0	Int16
35-4* Analog Input X48/2						
35-42	Term. X48/2 Low Current	4 mA	All set-ups	TRUE	-5	Int16
35-43	Term. X48/2 High Current	20 mA	All set-ups	TRUE	-5	Int16
35-44	Term. X48/2 Low Ref./Feedb. Value	0 N/A	All set-ups	TRUE	-3	Int32
35-45	Term. X48/2 High Ref./Feedb. Value	100 N/A	All set-ups	TRUE	-3	Int32
35-46	Term. X48/2 Filter Time Constant	0.001 s	All set-ups	TRUE	-3	Uint16
35-47	Term. X48/2 Live Zero	[1] Enabled	All set-ups	TRUE	-	Uint8

Table 4.29

5 Troubleshooting

5.1.1 Warnings/Alarm Messages

A warning or an alarm is signalled by the relevant LED on the front of the adjustable frequency drive and indicated by a code on the display.

A warning remains active until its cause is no longer present. Under certain circumstances operation of the motor may still be continued. Warning messages may be critical, but are not necessarily so.

In the event of an alarm, the adjustable frequency drive will have tripped. Alarms must be reset to restart operation once their cause has been rectified.

This may be done in three ways:

1. By pressing [Reset].
2. Via a digital input with the "Reset" function.
3. Via serial communication/optional serial communication bus.

NOTICE!

After a manual reset pressing [Reset], [Auto On] must be pressed to restart the motor.

If an alarm cannot be reset, the reason may be that its cause has not been rectified, or the alarm is trip-locked (see also *Table 5.1*).

Alarms that are trip-locked offer additional protection, meaning that the line power supply must be switched off before the alarm can be reset. After being switched back on, the adjustable frequency drive is no longer blocked and may be reset as described above, once the cause has been rectified.

Alarms that are not trip-locked can also be reset using the automatic reset function in *14-20 Reset Mode* (Warning: automatic wake-up is possible!)

If a warning and alarm is marked against a code in *Table 5.1*, this means that either a warning occurs before an alarm, or else that it is possible to specify whether it is a warning or an alarm that is to be displayed for a given fault.

This is possible, for instance, in *1-90 Motor Thermal Protection*. After an alarm or trip, the motor carries on coasting, and the alarm and warning flash. Once the problem has been rectified, only the alarm continues flashing until the adjustable frequency drive is reset.

No.	Description	Warning	Alarm/Trip	Alarm/Trip Lock	Parameter Reference
1	10 Volts low	X			
2	Live zero error	(X)	(X)		6-01 Live Zero Timeout Function
3	No motor	(X)			1-80 Function at Stop
4	Mains phase loss	(X)	(X)	(X)	14-12 Function at Mains Imbalance
5	DC link voltage high	X			
6	DC link voltage low	X			
7	DC overvoltage	X	X		
8	DC undervoltage	X	X		
9	Inverter overloaded	X	X		
10	Motor ETR overtemperature	(X)	(X)		1-90 Motor Thermal Protection
11	Motor thermistor overtemperature	(X)	(X)		1-90 Motor Thermal Protection
12	Torque limit	X	X		
13	Overcurrent	X	X	X	
14	Ground Fault	X	X	X	
15	Hardware mismatch		X	X	
16	Short-circuit		X	X	

No.	Description	Warning	Alarm/Trip	Alarm/Trip Lock	Parameter Reference
17	Control word timeout	(X)	(X)		8-04 Control Timeout Function
20	Temp. Input Error				
21	Param Error				
22	Hoist Mech. Brake	(X)	(X)		Parameter group 2-2*
23	Internal Fans	X			
24	External Fans	X			
25	Brake resistor short-circuited	X			
26	Brake resistor power limit	(X)	(X)		2-13 Brake Power Monitoring
27	Brake chopper short-circuited	X	X		
28	Brake check	(X)	(X)		2-15 Brake Check
29	Heatsink temp	X	X	X	
30	Motor phase U missing	(X)	(X)	(X)	4-58 Missing Motor Phase Function
31	Motor phase V missing	(X)	(X)	(X)	4-58 Missing Motor Phase Function
32	Motor phase W missing	(X)	(X)	(X)	4-58 Missing Motor Phase Function
33	Inrush fault		X	X	
34	Fieldbus communication fault	X	X		
35	Option Fault				
36	Mains failure	X	X		
37	Phase imbalance		X		
38	Internal Fault		X	X	
39	Heatsink sensor		X	X	
40	Overload of Digital Output Terminal 27	(X)			5-00 Digital I/O Mode, 5-01 Terminal 27 Mode
41	Overload of Digital Output Terminal 29	(X)			5-00 Digital I/O Mode, 5-02 Terminal 29 Mode
42	Ovrlid X30/6-7	(X)			
43	Ext. Supply (option)				
45	Earth Fault 2	X	X	X	
46	Pwr. card supply		X	X	
47	24 V supply low	X	X	X	
48	1.8 V supply low		X	X	
49	Speed limit	X			
50	AMA calibration failed		X		
51	AMA check Unom and Inom		X		
52	AMA low I _{nom}		X		
53	AMA motor too big		X		
54	AMA motor too small		X		
55	AMA parameter out of range		X		
56	AMA interrupted by user		X		
57	AMA timeout		X		
58	AMA internal fault	X	X		
59	Current limit	X			
60	External Interlock	X	X		

No.	Description	Warning	Alarm/Trip	Alarm/Trip Lock	Parameter Reference
61	Feedback Error	(X)	(X)		4-30 Motor Feedback Loss Function
62	Output Frequency at Maximum Limit	X			
63	Mechanical Brake Low		(X)		2-20 Release Brake Current
64	Voltage Limit	X			
65	Control Board Over Temperature	X	X	X	
66	Heat sink Temperature Low	X			
67	Option Configuration has Changed		X		
68	Safe Stop	(X)	(X) ¹⁾		5-19 Terminal 37 Digital Input
69	Pwr. Card Temp		X	X	
70	Illegal FC configuration			X	
71	PTC 1 Safe Stop				
72	Dangerous failure				
73	Safe Stop Auto Restart	(X)	(X)		5-19 Terminal 37 Digital Input
74	PTC Thermistor			X	
75	Illegal Profile Sel.		X		
76	Power Unit Setup	X			
77	Reduced power mode	X			14-59 Actual Number of Inverter Units
78	Tracking Error	(X)	(X)		4-34 Tracking Error Function
79	Illegal PS config		X	X	
80	Drive Initialized to Default Value		X		
81	CSIV corrupt		X		
82	CSIV parameter error		X		
83	Illegal Option Combination			X	
84	No Safety Option		X		
88	Option Detection			X	
89	Mechanical Brake Sliding	X			
90	Feedback Monitor	(X)	(X)		17-61 Feedback Signal Monitoring
91	Analog input 54 wrong settings			X	S202
163	ATEX ETR cur.lim.warning	X			
164	ATEX ETR cur.lim.alarm		X		
165	ATEX ETR freq.lim.warning	X			
166	ATEX ETR freq.lim.alarm		X		
243	Brake IGBT	X	X	X	
244	Heatsink temp	X	X	X	
245	Heatsink sensor		X	X	
246	Pwr.card supply			X	
247	Pwr.card temp		X	X	
248	Illegal PS config			X	
249	Rect. low temp.	X			
250	New spare parts			X	

No.	Description	Warning	Alarm/Trip	Alarm/Trip Lock	Parameter Reference
251	New Type Code		X	X	

Table 5.1 Alarm/Warning Code List

(X) Dependent on parameter

1) Cannot be Auto reset via 14-20 Reset Mode

A trip is the action when an alarm has appeared. The trip will coast the motor and can be reset by pressing [Reset] or make a reset by a digital input (parameter group 5-1* [1]). The original event that caused an alarm cannot damage the adjustable frequency drive or cause dangerous conditions. A trip lock is an action when an alarm occurs, which may damage the adjustable frequency drive or

connected parts. A trip lock situation can only be reset by power cycling.

LED indication	
Warning	yellow
Alarm	flashing red
Trip locked	yellow and red

Table 5.2

Bit	Hex	Dec	Alarm Word	Alarm Word 2	Warning Word	Warning Word 2	Extended Status Word
Alarm Word Extended Status Word							
0	00000001	1	Brake Check (A28)	ServiceTrip, Read/Write	Brake Check (W28)	reserved	Ramping
1	00000002	2	Heatsink temp. (A29)	ServiceTrip, (reserved)	Heatsink temp. (W29)	reserved	AMA Running
2	00000004	4	Ground Fault (A14)	ServiceTrip, Type Code/Spare Part	Ground Fault (W14)	reserved	Start CW/CCW start_possible is active, when the DI selections [12] OR [13] are active and the requested direction matches the reference sign
3	00000008	8	Ctrl.Card Temp (A65)	ServiceTrip, (reserved)	Ctrl.Card Temp (W65)	reserved	Slow-down slow-down command active, e.g., via CTW bit 11 or DI
4	00000010	16	Ctrl. Word TO (A17)	ServiceTrip, (reserved)	Ctrl. Word TO (W17)		Catch Up catch up command active, e.g., via CTW bit 12 or DI
5	00000020	32	Overcurrent (A13)	reserved	Overcurrent (W13)	reserved	Feedback High feedback > p4-57
6	00000040	64	Torque Limit (A12)	reserved	Torque Limit (W12)	reserved	Feedback Low feedback < p4-56
7	00000080	128	Motor Th Over (A11)	reserved	Motor Th Over (W11)	reserved	Output Current High current > p4-51
8	00000100	256	Motor ETR Over (A10)	reserved	Motor ETR Over (W10)	reserved	Output Current Low current < p4-50
9	00000200	512	Inverter Overld. (A9)	reserved	Inverter Overld (W9)	reserved	Output Freq High speed > p4-53
10	00000400	1024	DC undervolt (A8)	reserved	DC undervolt (W8)		Output Freq Low speed < p4-52
11	00000800	2048	DC overvoltage (A7)	reserved	DC overvoltage (W7)		Brake Check OK brake test NOT ok

Bit	Hex	Dec	Alarm Word	Alarm Word 2	Warning Word	Warning Word 2	Extended Status Word
12	00001000	4096	Short Circuit (A16)	reserved	DC Voltage Low (W6)	reserved	Braking Max BrakePower > BrakePowerLimit (p212)
13	00002000	8192	Inrush Fault (A33)	reserved	DC Voltage High (W5)		Braking
14	00004000	16384	Mains ph. Loss (A4)	reserved	Mains ph. Loss (W4)		Out of Speed Range
15	00008000	32768	AMA Not OK	reserved	No Motor (W3)		OVC Active
16	00010000	65536	Live Zero Error (A2)	reserved	Live Zero Error (W2)		AC Brake
17	00020000	131072	Internal Fault (A38)	KTY error	10 V Low (W1)	KTY Warn	Password Timelock number of allowed password trials exceeded - timelock active
18	00040000	262144	Brake Overload (A26)	Fans error	Brake Overload (W26)	Fans Warn	Password Protection p0-61 = ALL_NO_ACCESS OR BUS_NO_ACCESS OR BUS_READONLY
19	00080000	524288	U phase Loss (A30)	ECB error	Brake Resistor (W25)	ECB Warn	Reference High reference > p4-55
20	00100000	1048576	V phase Loss (A31)	reserved	Brake IGBT (W27)	reserved	Reference Low reference < p4-54
21	00200000	2097152	W phase Loss (A32)	reserved	Speed Limit (W49)	reserved	Local Reference reference site = REMOTE -> auto on pressed & active
22	00400000	4194304	Fieldbus Fault (A34)	reserved	Fieldbus Fault (W34)	reserved	Protection Mode
23	00800000	8388608	24 V Supply Low (A47)	reserved	24V Supply Low (W47)	reserved	Unused
24	01000000	16777216	Mains Failure (A36)	reserved	Mains Failure (W36)	reserved	Unused
25	02000000	33554432	1.8V Supply Low (A48)	reserved	Current Limit (W59)	reserved	Unused
26	04000000	67108864	Brake Resistor (A25)	reserved	Low Temp (W66)	reserved	Unused
27	08000000	134217728	Brake IGBT (A27)	reserved	Voltage Limit (W64)	reserved	Unused
28	10000000	268435456	Option Change (A67)	reserved	Encoder loss (W90)	reserved	Unused
29	20000000	536870912	Drive Initialized (A80)	Feedback Fault (A61, A90)	Feedback Fault (W61, W90)		Unused
30	40000000	1073741824	Safe Stop (A68)	PTC 1 Safe Stop (A71)	Safe Stop (W68)	PTC 1 Safe Stop (W71)	Unused
31	80000000	2147483648	Mech. brake low (A63)	Dangerous Failure (A72)	Extended Status Word		Unused

Table 5.3 Description of Alarm Word, Warning Word and Extended Status Word

The alarm words, warning words and extended status words can be read out via serial bus or optional serial communication bus for diagnosis. See also 16-94 Ext. Status Word.

Index

>

>Mains Power On/Off..... 2-85

A

Abbreviations..... 0-1

Acceleration Time..... 2-34

Adj.

 Freq. Drive Closed-loop..... 3-16

 Freq. Drive Information..... 3-12

Alarm

 Log..... 2-95

 Messages..... 4-1

Analog

 I/O Option MCB 109..... 2-158, 3-21

 In/Out..... 3-8

 Input Scaling Value..... 2-160

 Inputs..... 0-2

Application Functions..... 3-18

Auto Derate..... 2-90

B

Brakes..... 3-4

Braking Energy..... 0-3

Break-away Torque..... 0-2

Broken Belt Detection..... 2-131

Bus Controlled..... 2-55

Bypass Option..... 3-24

C

CAN Fieldbus..... 3-11

Cascade

 Controller..... 2-147, 3-20

 CTL Option..... 3-21

Changing

 A Group Of Numeric Data Values..... 1-9

 A Text Value..... 1-9

 Data..... 1-8

Clock Settings..... 2-12

Coasting..... 0-2, 1-4

Comm. And Options..... 3-9

Configuration..... 2-63

Control Cables..... 0-7

Cooling..... 2-27

Current Limit Control..... 2-88

D

Data

 Log Settings..... 2-92

 Readouts..... 3-14

 Readouts 2..... 3-15

Default Settings..... 3-1, 1-12

Definitions..... 0-2

DeviceNet..... 2-68

Digital In/Out..... 3-7

Display

 Line 1.2 Small, 0-21..... 2-8

 Line 1.3 Small, 0-22..... 2-8

 Line 2 Large, 0-23..... 2-8

 Line 3 Large, 0-24..... 2-8

 Mode..... 1-4

 Mode - Selection Of Readouts..... 1-4

Drive

 Closed-loop..... 2-106

 Identification..... 2-96

 Information..... 2-92

E

Electrical Terminals..... 0-6

End Of Curve..... 2-130

Energy

 Log..... 2-140

 Optimizing..... 2-88

Environment..... 2-89

ETR..... 2-99

Ext. Closed-loop..... 3-17

Extended CL Autotuning..... 2-115

F

Feedback

 Feedback..... 2-106

 & Setpoint..... 2-109

Flow Compensation..... 2-132

Freeze Output..... 0-2

G

Graphical Display..... 1-1

H

Historic Log..... 2-94

I

Indexed Parameters..... 1-10

Infinitely Variable Change Of Numeric Data Value..... 1-9

Initialization.....	1-12	Parameters 15-** Adjustable Frequency Drive Information.....	2-92
IT Line Power.....	2-89	Password.....	2-12
J		PID	
Jog.....	0-2	Autotuning.....	2-112
L		Basic Settings.....	2-113
Language		Controller.....	2-114
Package 1.....	2-2	Pipe	
Package 2.....	2-2	Fill Function.....	2-163
LCP.....	0-2, 0-3, 1-1, 1-4, 1-10	Fill Mode.....	2-163
LEDs.....	1-1, 1-2	Potentiometer Reference	0-8
Limits / Warnings.....	3-6	Profibus	3-10
Line		Protection Mode	0-5
Power RFI Filter Circuit.....	2-89	Pulse Start/Stop	0-8
Power Supply.....	0-4	Q	
Load/Motor	3-3	Q3 Function Set-ups	1-7
Local		Quick	
Control Keys.....	1-1	Menu.....	1-2, 1-5, 2-2
Reference.....	2-3	Menu Mode.....	1-3, 1-5
M		Transfer Of Parameter Settings Between Multiple Adjustable Frequency Drives.....	1-4
Main		R	
Menu.....	1-5, 2-2	Rated Motor Speed	0-2
Menu Mode.....	1-3, 1-8	RCD	0-3
Reactance.....	2-19	Reference / Ramps	3-5
MCB 114	2-168	Relay Outputs	2-47
Motor		Reset	1-4
Protection.....	2-27	S	
Status.....	2-98	Safety Precautions	0-4
N		Sensor Input Option 35-**	3-24
No Trip At Inverter Overload	2-90	Serial Communication	0-2
Numerical Local Control Panel	1-10	Shielded/armored	0-7
O		Short Cycle Protection	2-131
Operating Mode	2-3	Sleep Mode	2-127
Operation/Display	3-2	Smart Logic	3-11
Option Ident	2-97	Special Functions	3-12
P		Speed Up/Down	0-8
Parameter		Start	
Access.....	2-71	Delay.....	2-25
Info.....	2-97	Function.....	2-25
Options.....	3-1	Start/Stop	0-7
Selection.....	1-8, 2-1	Stator Leakage Reactance	2-19
Set-up.....	2-1	Status	
Set-Up.....	1-5	Status.....	1-2
		Messages.....	1-1

Step-by-Step.....	1-9
Symbols.....	0-1
Synchronous Motor Speed.....	0-2
T	
Thermal Load.....	2-99
Thermistor.....	0-4
Timed Actions.....	2-136, 3-19
Trending.....	2-142
Trip Reset.....	2-86
V	
Value.....	1-9
Voltage Reference Via A Potentiometer.....	0-8
WVplus.....	0-4
W	
Warnings.....	4-1
Water Application Functions.....	2-163, 3-23



www.danfoss.com/drives

Danfoss shall not be responsible for any errors in catalogs, brochures or other printed material. Danfoss reserves the right to alter its products at any time without notice, provided that alterations to products already on order shall not require material changes in specifications previously agreed upon by Danfoss and the Purchaser. All trademarks in this material are property of the respective companies. Danfoss and the Danfoss logotype are trademarks of Danfoss A/S. All rights reserved.

Danfoss Drives

4401 N. Bell School Rd.
Loves Park IL 61111 USA
Phone: 1-800-432-6367
1-815-639-8600
Fax: 1-815-639-8000
www.danfossdrives.com

Danfoss Drives

8800 W. Bradley Rd.
Milwaukee, WI 53224 USA
Phone: 1-800-621-8806
1-414-355-8800
Fax: 1-414-355-6117
www.danfossdrives.com

