

Contents

1 How to Read this Instruction Manual	3
Copyright, Limitation of Liability and Revision Rights	4
Approvals	5
Symbols	5
2 Safety	7
General Warning	8
Before Commencing Repair Work	8
Special Conditions	8
Caution	8
Avoid Un-intended Start	9
IT Mains	9
Safe Stop of the Frequency Converter (Optional)	9
3 Introduction	11
Type Code String - Medium Power	11
4 Mechanical Installation	15
Before Starting	15
5 Electrical Installation	21
How to Connect	21
Mains Wiring Overview	23
Motor Wiring Overview	33
DC Bus Connection	39
Brake Connection Option	41
Relay Connection	42
Electrical Installation and Control Cables	49
How to Test Motor and Direction of Rotation	50
6 Commissioning and Application Examples	55
Quick Setup	55
Start/Stop	56
Closed Loop Wiring	56
Submersible Pump Application	57
7 How to Operate the Frequency Converter	59
Ways of Operation	59
How to Operate Graphical LCP (GLCP)	59

How to Operate Numeric (NLCP)	64
Tips and Tricks	68
8 How to Programme the Frequency Converter	73
How to Programme	73
Commonly Used Parameters - Explanations	78
Main Menu	78
Parameter Options	121
Default Settings	121
Operation/Display 0-**	122
Load/Motor 1-**	124
Brakes 2-**	126
Reference / Ramps 3-**	127
Limits / Warnings 4-**	128
Digital In/Out 5-**	129
Analog In/Out 6-**	130
Comm. and Options 8-**	131
Profibus 9-**	132
CAN Fieldbus 10-**	133
Smart Logic 13-**	134
Special Functions 14-**	135
FC Information 15-**	136
Data Readouts 16-**	138
Data Readouts 2 18-**	140
FC Closed Loop 20-**	141
Ext. Closed Loop 21-**	142
Application Functions 22-**	144
Timed Actions 23-**	146
Cascade Controller 25-**	147
Analog I/O Option MCB 109 26-**	149
Water Application Functions 29-**	152
Bypass Option 31-**	153
9 Troubleshooting	155
Fault Messages	158
10 Specifications	163
Special Conditions	179
Index	181

1 How to Read this Instruction Manual

1

Automation VT Drive FC322 Series Software version: 1.7x



This guide can be used with all FC322 frequency converters with software version 1.7x or later.

The actual software version number can be read from par. 15-43 *Software Version*.

1**1.1.1 Copyright, Limitation of Liability and Revision Rights**

This publication contains information proprietary to . By accepting and using this manual the user agrees that the information contained herein will be used solely for operating equipment from or equipment from other vendors provided that such equipment is intended for communication with equipment over a serial communication link. This publication is protected under the Copyright laws of Denmark and most other countries.

does not warrant that a software program produced according to the guidelines provided in this manual will function properly in every physical, hardware or software environment.

Although has tested and reviewed the documentation within this manual, makes no warranty or representation, neither expressed nor implied, with respect to this documentation, including its quality, performance, or fitness for a particular purpose.

In no event shall be liable for direct, indirect, special, incidental, or consequential damages arising out of the use, or the inability to use information contained in this manual, even if advised of the possibility of such damages. In particular, is not responsible for any costs, including but not limited to those incurred as a result of lost profits or revenue, loss or damage of equipment, loss of computer programs, loss of data, the costs to substitute these, or any claims by third parties.

reserves the right to revise this publication at any time and to make changes to its contents without prior notice or any obligation to notify former or present users of such revisions or changes.

1.1.2 Available Literature for Automation VT Drive FC322

- Automation VT Drive Instruction Manual MG.20.U1.22 provide the necessary information for getting the drive up and running.
- Automation VT Drive High Power Instruction Manual MG.20.V1.22 provide the necessary information for getting the HP drive up and running.
- Automation VT Drive Design Guide MG.20.X1.22 entails all technical information about the drive and customer design and applications.
- Automation VT Drive Programming Guide MN.20.W1.22 provides information on how to programme and includes complete parameter descriptions.

technical literature is also available online at

www.danfoss.com/BusinessAreas/DrivesSolutions/Documentations/Technical+Documentation.htm.

1.1.3 Approvals

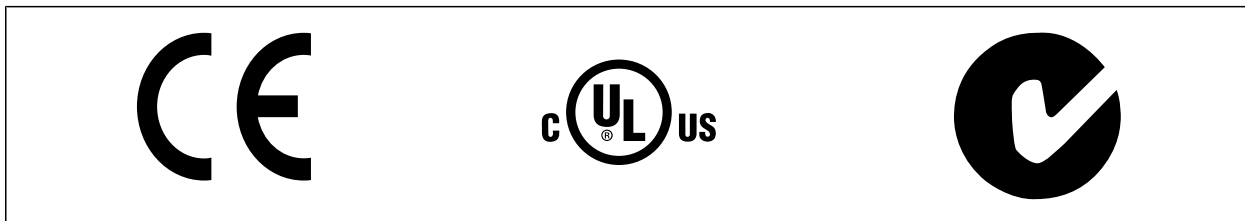

1.1.4 Symbols

Symbols used in this Instruction Manual.

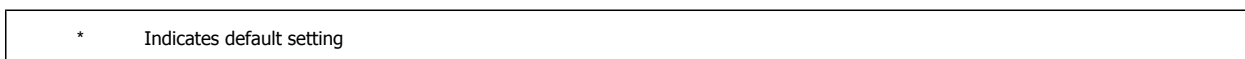

2

2 Safety

2.1.1 Safety Note



The voltage of the frequency converter is dangerous whenever connected to mains. Incorrect installation of the motor, frequency converter or fieldbus may cause damage to the equipment, serious personal injury or death. Consequently, the instructions in this manual, as well as national and local rules and safety regulations, must be complied with.

Safety Regulations

1. The frequency converter must be disconnected from mains if repair work is to be carried out. Check that the mains supply has been disconnected and that the necessary time has passed before removing motor and mains plugs.
2. The [STOP/RESET] key on the control panel of the frequency converter does not disconnect the equipment from mains and is thus not to be used as a safety switch.
3. Correct protective earthing of the equipment must be established, the user must be protected against supply voltage, and the motor must be protected against overload in accordance with applicable national and local regulations.
4. The earth leakage currents are higher than 3.5 mA.
5. Protection against motor overload is set by par. 1-90 *Motor Thermal Protection*. If this function is desired, set par. 1-90 to data value [ETR trip] (default value) or data value [ETR warning]. Note: The function is initialised at 1.16 x rated motor current and rated motor frequency. For the North American market: The ETR functions provide class 20 motor overload protection in accordance with NEC.
6. Do not remove the plugs for the motor and mains supply while the frequency converter is connected to mains. Check that the mains supply has been disconnected and that the necessary time has passed before removing motor and mains plugs.
7. Please note that the frequency converter has voltage inputs other than L1, L2 and L3, when load sharing (linking of DC intermediate circuit) and external 24 V DC have been installed. Check that all voltage inputs have been disconnected and that the necessary time has passed before commencing repair work.

Installation at High Altitudes



Installation at high altitude:

380 - 480 V: At altitudes above 3 km, please contact Danfoss Drives regarding PELV.
525 - 690 V: At altitudes above 2 km, please contact Danfoss Drives regarding PELV.

Warning against Unintended Start

1. The motor can be brought to a stop by means of digital commands, bus commands, references or a local stop, while the frequency converter is connected to mains. If personal safety considerations make it necessary to ensure that no unintended start occurs, these stop functions are not sufficient.
2. While parameters are being changed, the motor may start. Consequently, the stop key [RESET] must always be activated; following which data can be modified.
3. A motor that has been stopped may start if faults occur in the electronics of the frequency converter, or if a temporary overload or a fault in the supply mains or the motor connection ceases.



Warning:

Touching the electrical parts may be fatal - even after the equipment has been disconnected from mains.

Also make sure that other voltage inputs have been disconnected, such as external 24 V DC, load sharing (linkage of DC intermediate circuit), as well as the motor connection for kinetic back up.

2.1.2 General Warning



Leakage Current

The earth leakage current from the Automation VT Drive FC322 exceeds 3.5 mA. According to IEC 61800-5-1 a reinforced Protective Earth connection must be ensured by means of: a min. 10mm² Cu or 16mm² Al PE-wire or an additional PE wire - with the same cable cross section as the Mains wiring - must be terminated separately.

Residual Current Device

This product can cause a D.C. current in the protective conductor. Where a residual current device (RCD) is used for extra protection, only an RCD of Type B (time delayed) shall be used on the supply side of this product. See also RCD Application Note MN.90.GX.02. Protective earthing of the Automation VT Drive FC322 and the use of RCD's must always follow national and local regulations.

2.1.3 Before Commencing Repair Work

1. Disconnect the frequency converter from mains
2. Disconnect DC bus terminals 88 and 89
3. Wait at least the time mentioned in section General Warning above
4. Remove motor cable

2.1.4 Special Conditions

Electrical ratings:

The rating indicated on the nameplate of the frequency converter is based on a typical 3-phase mains power supply, within the specified voltage, current and temperature range, which is expected to be used in most applications.

The frequency converters also support other special applications, which affect the electrical ratings of the frequency converter. Special conditions which affect the electrical ratings might be:

- Single phase applications
- High temperature applications which require derating of the electrical ratings
- Marine applications with more severe environmental conditions.

Consult the relevant clauses in these instructions and in the **Automation VT Drive Design Guide** for information about the electrical ratings.

Installation requirements:

The overall electrical safety of the frequency converter requires special installation considerations regarding:

- Fuses and circuit breakers for over-current and short-circuit protection
- Selection of power cables (mains, motor, brake, loadsharing and relay)
- Grid configuration (IT, TN, grounded leg, etc.)
- Safety of low-voltage ports (PELV conditions).

Consult the relevant clauses in these instructions and in the **Automation VT Drive Design Guide** for information about the installation requirements.

2.1.5 Caution



The frequency converter DC link capacitors remain charged after power has been disconnected. To avoid an electrical shock hazard, disconnect the frequency converter from the mains before carrying out maintenance. Wait at least as follows before doing service on the frequency converter:

Voltage (V)	Min. Waiting Time (Minutes)				
	4	15	20	30	40
200 - 240	0.25 - 3.7 kW	5.5 - 45 kW			
380 - 480	0.37 - 7.5 kW	11 - 90 kW	110 - 250 kW		315 - 1000 kW
525-600	0.75 kW - 7.5 kW	11 - 90 kW			
525-690		11 - 90 kW	45 - 400 kW	450 - 1200 kW	

Be aware that there may be high voltage on the DC link even when the LEDs are turned off.

2.1.6 Avoid Un-intended Start

NB!
While the frequency converter is connected to mains, the motor can be started/stopped using digital commands, bus commands, references or via the Local Control Panel.

- Disconnect the frequency converter from mains whenever personal safety considerations make it necessary to avoid unintended start.
- To avoid unintended start, always activate the [OFF] key before changing parameters.
- Unless terminal 37 is turned off, an electronic fault, temporary overload, a fault in the mains supply, or lost motor connection may cause a stopped motor to start.

2.1.7 IT Mains



IT mains
Do not connect frequency converters with RFI-filters to mains supplies with a voltage between phase and earth of more than 440 V for 400 V converters and 760 V for 690 V converters.
For 400 V IT mains and delta earth (grounded leg), mains voltage may exceed 440 V between phase and earth.
For 690 V IT mains and delta earth (grounded leg), mains voltage may exceed 760 V between phase and earth.

Par. 14-50 *RFI Filter* can be used to disconnect the internal RFI capacitors from the RFI filter to ground.

2.1.8 Disposal Instruction



Equipment containing electrical components must not be disposed of together with domestic waste. It must be separately collected with electrical and electronic waste according to local and currently valid legislation.

2.1.9 Safe Stop of the Frequency Converter (Optional)

For versions fitted with a Safe Stop terminal 37 input, the frequency converter can perform the safety function *Safe Torque Off* (As defined by draft CD IEC 61800-5-2) or *Stop Category 0* (as defined in EN 60204-1).

It is designed and approved suitable for the requirements of Safety Category 3 in EN 954-1. This functionality is called Safe Stop. Prior to integration and use of Safe Stop in an installation, a thorough risk analysis on the installation must be carried out in order to determine whether the Safe Stop functionality and safety category are appropriate and sufficient. In order to install and use the Safe Stop function in accordance with the requirements of Safety

Category 3 in EN 954-1, the related information and instructions of the Automation VT Drive Design Guide MG.20.X1.22 must be followed! The information and instructions of the Instruction Manual are not sufficient for a correct and safe use of the Safe Stop functionality!

2

3 Introduction

3.1.1 Type Code String - Medium Power

1	2	3	4	5	6	7	8	9	10	11	12	13	14	15	16	17	18	19	20	21	22	23	24	25	26	27	28	29	30	31	32	33	34	35	36	37	38	39
F	C	-	2	0	2	P				T					H						X	X	S	X	X	X	X	A		B		C						D

130BA484.10



Description	Pos.:	Possible choice
Product group & VLT Series	1-6	FC 322
Power rating	7-10	0.25 - 1200 kW
Number of phases	11	Three phases (T)
Mains voltage	11-12	S2: 220-240 VAC single phase S4: 380-480 VAC single phase T 2: 200-240 VAC T 4: 380-480 VAC T 6: 525-600 VAC T 7: 525-690 VAC
Enclosure	13-15	E20: IP20 E21: IP 21/NEMA Type 1 E55: IP 55/NEMA Type 12 E2M: IP21/NEMA Type 1 w/mains shield E5M: IP 55/NEMA Type 12 w/mains shield E66: IP66 F21: IP21 kit without backplate G21: IP21 kit with backplate P20: IP20/Chassis with backplate P21: IP21/NEMA Type 1 w/backplate P55: IP55/NEMA Type 12 w/backplate
RFI filter	16-17	HX: No RFI filter H1: RFI filter class A1/B H2: RFI filter class A2 H3: RFI filter class A1/B (reduced cable length) H4: RFI filter class A2/A1
Brake	18	X: No brake chopper included B: Brake chopper included T: Safe Stop U: Safe + brake
Display	19	G: Graphical Local Control Panel (GLCP) N: Numeric Local Control Panel (NLCP) X: No Local Control Panel
Coating PCB	20	X: No coated PCB C: Coated PCB
Mains option	21	D: Loadsharing X: No Mains disconnect switch 8: Mains Disconnect + Loadsharing
Cable entries	22	X: Standard cable entries O: European metric thread in cable entries
	23	Reserved
Software release	24-27	Actual software version
Software language	28	
A options	29-30	AX: No options A0: MCA 101 Profibus DP V1 A4: MCA 104 DeviceNet AN: MCA 121 Ethernet IP
B options	31-32	BX: No option BK: MCB 101 General purpose I/O option BP: MCB 105 Relay option BO: MCB 109 Analog I/O option BY: MCO 101 Extended Cascade Control
C ₀ options	33-34	CX: No options
C ₁ options	35	X: No options 5: MCO 102 Advanced Cascade Control
C option software	36-37	XX: Standard software
D options	38-39	DX: No option D0: DC backup

The various options are described further in this Design Guide.

Table 3.1: Type code description.

3.1.2 Frequency Converter Identification

Below is an example of an identification label. This label is situated on the frequency converter and shows the type and options fitted to the unit. See table 2.1 for details of how to read the Type code string (T/C).

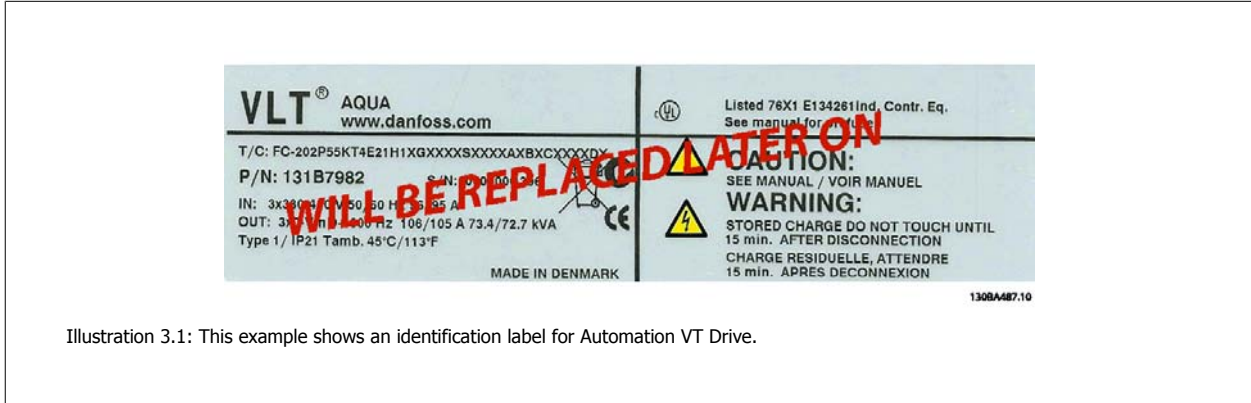

Illustration 3.1: This example shows an identification label for Automation VT Drive.

Please have T/C (type code) number and serial number ready before contacting Danfoss.

3.1.3 Abbreviations and Standards

Abbreviations:	Terms:	SI-units:	I-P units:
a	Acceleration	m/s ²	ft/s ²
AWG	American wire gauge		
Auto Tune	Automatic Motor Tuning		
°C	Celsius		
I	Current	A	Amp
I _{LIM}	Current limit		
Joule	Energy	J = N*m	ft-lb, Btu
°F	Fahrenheit		
FC	Frequency Converter		
f	Frequency	Hz	Hz
kHz	Kilohertz	kHz	kHz
	Local Control Panel		
mA	Milliamperere		
ms	Millisecond		
min	Minute		
MCT	Motion Control Tool		
M-TYPE	Motor Type Dependent		
Nm	Newton Metres		in-lbs
I _{M,N}	Nominal motor current		
f _{M,N}	Nominal motor frequency		
P _{M,N}	Nominal motor power		
U _{M,N}	Nominal motor voltage		
par.	Parameter		
PELV	Protective Extra Low Voltage		
Watt	Power	W	Btu/hr, hp
Pascal	Pressure	Pa = N/m ²	psi, psf, ft of water
I _{INV}	Rated Inverter Output Current		
RPM	Revolutions Per Minute		
SR	Size Related		
T	Temperature	C	F
t	Time	s	s,hr
T _{LIM}	Torque limit		
U	Voltage	V	V

Table 3.2: Abbreviation and standards table .

4

4 Mechanical Installation

4.1 Before Starting

4.1.1 Checklist

When unpacking the frequency converter, ensure that the unit is undamaged and complete. Use the following table to identify the packaging:

Enclosure type:	A2 (IP 20/ 21)	A3 (IP 20/21)	A5 (IP 55/ 66)	B1/B3 (IP20/ 21/ 55/ 66)	B2/B4 (IP20/ 21/ 55/66)	C1/C3 (IP20/21/ 55/66)	C2/C4 (IP20/21/ 55/66)
Unit size (kW):							
200-240 V	0.25-3.0	3.7	0.25-3.7	5.5-11/ 5.5-11	15/ 15-18.5	18.5-30/ 22-30	37-45/ 37-45
380-480 V	0.37-4.0	5.5-7.5	0.37-7.5	11-18.5/ 11-18.5	22-30/ 22-37	37-55/ 45-55	75 - 90/ 75-90
525-600 V		0.75-7.5	0.75-7.5	11-18.5/ 11-18.5	22-37/ 22-37	45-55/ 45-55	75 - 90/ 75-90
525-690 V	-	-	-	-/ -	11-30/ -	-/ -	37-90/ -

Table 4.1: Unpacking table

Please note that a selection of screwdrivers (philips or cross-thread screwdriver and torx), a side-cutter, drill and knife is also recommended to have handy for unpacking and mounting the frequency converter. The packaging for these enclosures contains, as shown: Accessories bag(s), documentation and the unit. Depending on options fitted there may be one or two bags and one or more booklets.

4.2.1 Mechanical Front Views

A2		IP20/21*
A3		IP20/21*
A5		IP55/66
B1		IP21/55/66
B2		IP21/55/66
B3		IP20/21*
B4		IP20/21*
C1		IP21/55/66
C2		IP21/55/66
C3		IP20/21*
C4		IP20/21*

Illustration 4.1: Top and bottom mounting holes.

Illustration 4.2: Top and bottom mounting holes. (B4+C3+C4 only)

Accessory bags containing necessary brackets, screws and connectors are included with the drives upon delivery.

All measurements in mm.

* IP21 can be established with a kit as described in the section: IP 21/ IP 4X/ TYPE 1 Enclosure Kit in the Design Guide.

4.2.2 Mechanical Dimensions

Frame size (kW):		Mechanical dimensions											
		A2	A3	A5	B1	B2	B3	B4	C1	C2	C3	C4	
200-240 V	T2	0.25-3.0	3.7	0.25-3.7	5.5-11	15	5.5-11	15-18.5	18.5-30	37-45	22-30	37-45	
380-480 V	T4	0.37-4.0	5.5-7.5	0.37-7.5	11-18.5	22-30	11-18.5	22-37	37-55	75-90	45-55	75-90	
525-600 V	T6	-	0.75-7.5	0.75-7.5	11-18.5	22-30	11-18.5	22-37	37-55	75-90	45-55	75-90	
525-690 V	T7	-	-	-	-	11-30	-	-	-	37-90	-	-	
IP		20	21	55/66	21/55/66	21/55/66	20	20	21/55/66	21/55/66	20	20	
NEMA		Chassis	Type 1	Type 12	Type 1/12	Type 1/12	Chassis	Chassis	Type 1/12	Type 1/12	Chassis	Chassis	
Height (mm)													
Enclosure	A**	246	372	420	480	650	350	460	680	770	490	600	
..with de-coupling plate	A2	374	-	-	-	-	419	595	-	-	630	800	
Back plate	A1	268	375	420	480	650	399	520	680	770	550	660	
Distance between mount. holes	a	257	350	402	454	624	380	495	648	739	521	631	
Width (mm)													
Enclosure	B	90	130	242	242	242	165	231	308	370	308	370	
With one C option	B	130	170	242	242	242	205	231	308	370	308	370	
Back plate	B	90	130	242	242	242	165	231	308	370	308	370	
Distance between mount. holes	b	70	110	215	210	210	140	200	272	334	270	330	
Depth (mm)													
Without option A/B	C	205	205	200	260	260	248	242	310	335	333	333	
With option A/B	C*	220	220	200	260	260	262	242	310	335	333	333	
Screw holes (mm)													
Diameter ϕ	c	8.0	8.0	8.2	12	12	8	-	12	12	-	-	
Diameter ϕ	d	11	11	12	19	19	12	-	19	19	-	-	
Diameter ϕ	e	5.5	5.5	6.5	9	9	6.8	8.5	9.0	9.0	8.5	8.5	
Diameter ϕ	f	9	9	9	9	9	7.9	15	9.8	9.8	17	17	
Max weight (kg)													
		4.9	5.3	14	23	27	12	23.5	45	65	35	50	

* Depth of enclosure will vary with different options installed.

** The free space requirements are above and below the bare enclosure height measurement A. See section 3.2.3 for further information.

4.2.3 Mechanical Mounting

All IP20 enclosure sizes as well as IP21/ IP55 enclosure sizes except A2 and A3 allow side-by-side installation.

If the IP 21 Enclosure kit (130B1122 or 130B1123) is used on enclosure A2 or A3, there must be a clearance between the drives of min. 50 mm.

For optimal cooling conditions allow a free air passage above and below the frequency converter. See table below.

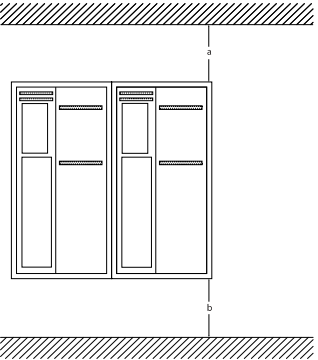

Air passage for different enclosures

Enclosure:	A2	A3	A5	B1	B2	B3	B4	C1	C2	C3	C4
a (mm):	100	100	100	200	200	200	200	200	225	200	225
b (mm):	100	100	100	200	200	200	200	200	225	200	225

1. Drill holes in accordance with the measurements given.
2. You must provide screws suitable for the surface on which you want to mount the frequency converter. Re-tighten all four screws.

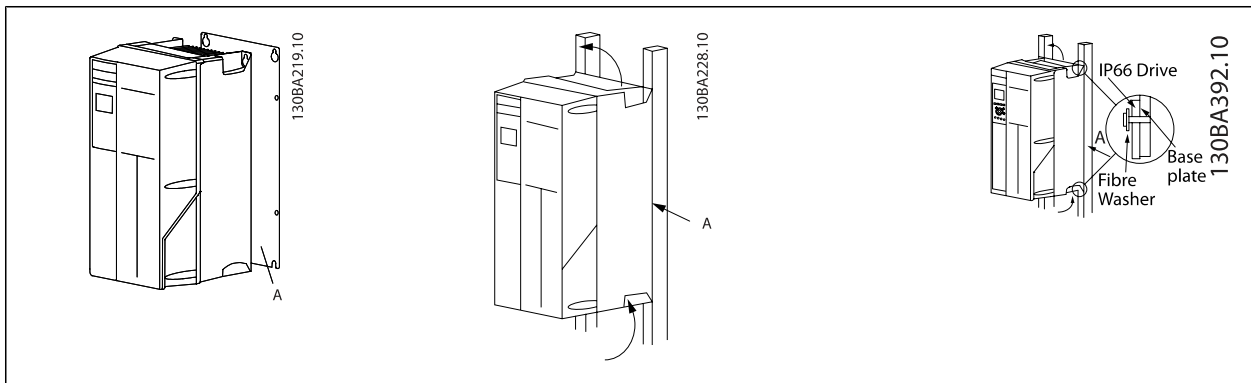

Table 4.2: Mounting frame sizes A5, B1, B2, B3, B4, C1, C2, C3 and C4 on a non-solid back wall, the drive must be provided with a back plate A due to insufficient cooling air over the heat sink.

With heavier drives (B4, C3, C4) use a lift. First wall-mount the 2 lower bolts - then lift the drive onto the lower bolts - finally fasten the drive against the wall with the 2 top bolts.

4.2.4 Safety Requirements of Mechanical Installation



Pay attention to the requirements that apply to integration and field mounting kit. Observe the information in the list to avoid serious damage or injury, especially when installing large units.

The frequency converter is cooled by means of air circulation.

To protect the unit from overheating, it must be ensured that the ambient temperature *does not exceed the maximum temperature stated for the frequency converter* and that the 24-hour average temperature *is not exceeded*. Locate the maximum temperature and 24-hour average in the paragraph *Derating for Ambient Temperature*.

If the ambient temperature is in the range of 45 °C - 55 °C, derating of the frequency converter will become relevant, see *Derating for Ambient Temperature*.

The service life of the frequency converter is reduced if derating for ambient temperature is not taken into account.

4.2.5 Field Mounting

For field mounting the IP 21/IP 4X top/TYPE 1 kits or IP 54/55 units are recommended.

4.2.6 Panel Through Mounting

A Panel Through Mount Kit is available for frequency converter series Automation VT Drive.

In order to increase heatsink cooling and reduce panel depth, the frequency converter may be mounted in a through panel. Furthermore the in-built fan can then be removed.

The kit is available for enclosures A5 through C2.



NB!

This kit cannot be used with cast front covers. No cover or IP21 plastic cover must be used instead.

Information on ordering numbers is found in the *Design Guide*, section *Ordering Numbers*.

More detailed information is available in the *Panel Through Mount Kit instruction*, *MI.33.H1.YY*, where yy=language code.

5 Electrical Installation

5.1 How to Connect

5.1.1 Cables General



NB!

Always comply with national and local regulations on cable cross-sections.

Details of terminal tightening torques.

Enclosure	Power (kW)			Torque (Nm)					
	200-240 V	380-480 V	525-600 V	Mains	Motor	DC connection	Brake	Earth	Relay
A2	0.25 - 3.0	0.37 - 4.0		1.8	1.8	1.8	1.8	3	0.6
A3	3.7	5.5 - 7.5	0.75 - 7.5	1.8	1.8	1.8	1.8	3	0.6
A5	0.25 - 3.7	0.37 - 7.5	0.75 - 7.5	1.8	1.8	1.8	1.8	3	0.6
B1	5.5 - 11	11 - 18.5	-	1.8	1.8	1.5	1.5	3	0.6
B2	-	22	-	4.5	4.5	3.7	3.7	3	0.6
	15	30	-	4.5 ²⁾	4.5 ²⁾	3.7	3.7	3	0.6
B3	5.5 - 11	11 - 18.5	11 - 18.5	1.8	1.8	1.8	1.8	3	0.6
B4	15 - 18.5	22 - 37	22 - 37	4.5	4.5	4.5	4.5	3	0.6
C1	18.5 - 30	37 - 55	-	10	10	10	10	3	0.6
C2	37	75	-	14	14	14	14	3	0.6
	45	90	-	24	24	14	14	3	0.6
C3	22 -	45 -	45 -	10	10	10	10	3	0.6
	30	55	55	10	10	10	10	3	0.6
C4	37 -	75 -	75 -	14	14	14	14	3	0.6
	45	90	90	24 ¹⁾	24 ¹⁾	14	14	3	0.6

Table 5.1: Tightening of terminals

1. For different cable dimensions x/y where $x \leq 95 \text{ mm}^2$ and $y \geq 95 \text{ mm}^2$.
2. Cable dimensions above 18.5 kW $\geq 35 \text{ mm}^2$ and below 22 kW $\leq 10 \text{ mm}^2$

5.1.2 Earthing and IT Mains



The earth connection cable cross section must be at least 10 mm² or 2 rated mains wires terminated separately according to *EN 50178* or *IEC 61800-5-1* unless national regulations specify differently. Always comply with national and local regulations. on cable cross-sections.

The mains is connected to the main disconnect switch if this is included.



NB!

Check that mains voltage corresponds to the mains voltage of the frequency converter name plate.

5

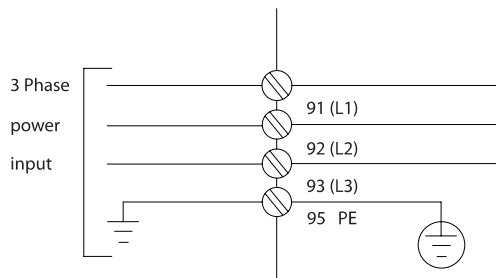

Illustration 5.1: Terminals for mains and earthing.



IT Mains

Do not connect 400 V frequency converters with RFI-filters to mains supplies with a voltage between phase and earth of more than 440 V.

For IT mains and delta earth (grounded leg), mains voltage may exceed 440 V between phase and earth.

5.1.3 Mains Wiring Overview

Enclosure:	A2 (IP 20/IP 21)	A3 (IP 20/IP 21)	A5 (IP 55/IP 66)	B1 (IP 21/IP 55/IP 66)	B2 (IP 21/IP 55/IP 66)	B3 (IP 20)	B4 (IP 20)	C1 (IP 21/IP 55/66)	C2 (IP 21/IP 55/66)	C3 (IP 20)	C4 (IP 20)
Motor size (kW):	0.25-3.0	3.7	1.1-3.7	5.5-11	15	5.5-11	15-18.5	18.5-30	37-45	22-30	37-45
200-240 V	0.37-4.0	5.5-7.5	1.1-7.5	11-18.5	22-30	11-18.5	22-37	37-55	75-90	45-55	75-90
380-480 V	'	1.1-7.5	1.1-7.5	11-18.5	22-30	11-18.5	22-37	37-55	75-90	45-55	75-90
525-600 V											
525-690 V					11-30				37-90		
Goto:	5.1.6		5.1.7		5.1.8		5.1.9		5.1.10		

Table 5.2: Mains wiring table.

5

5.1.4 Mains Connection for A2 and A3

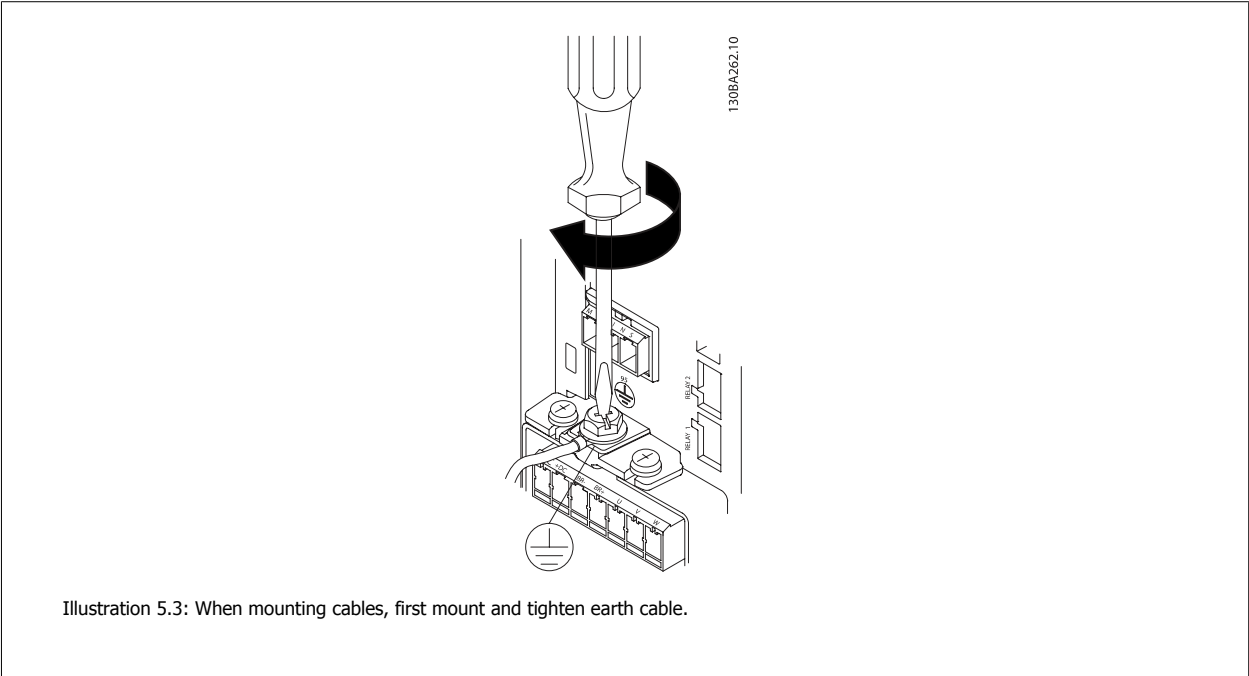
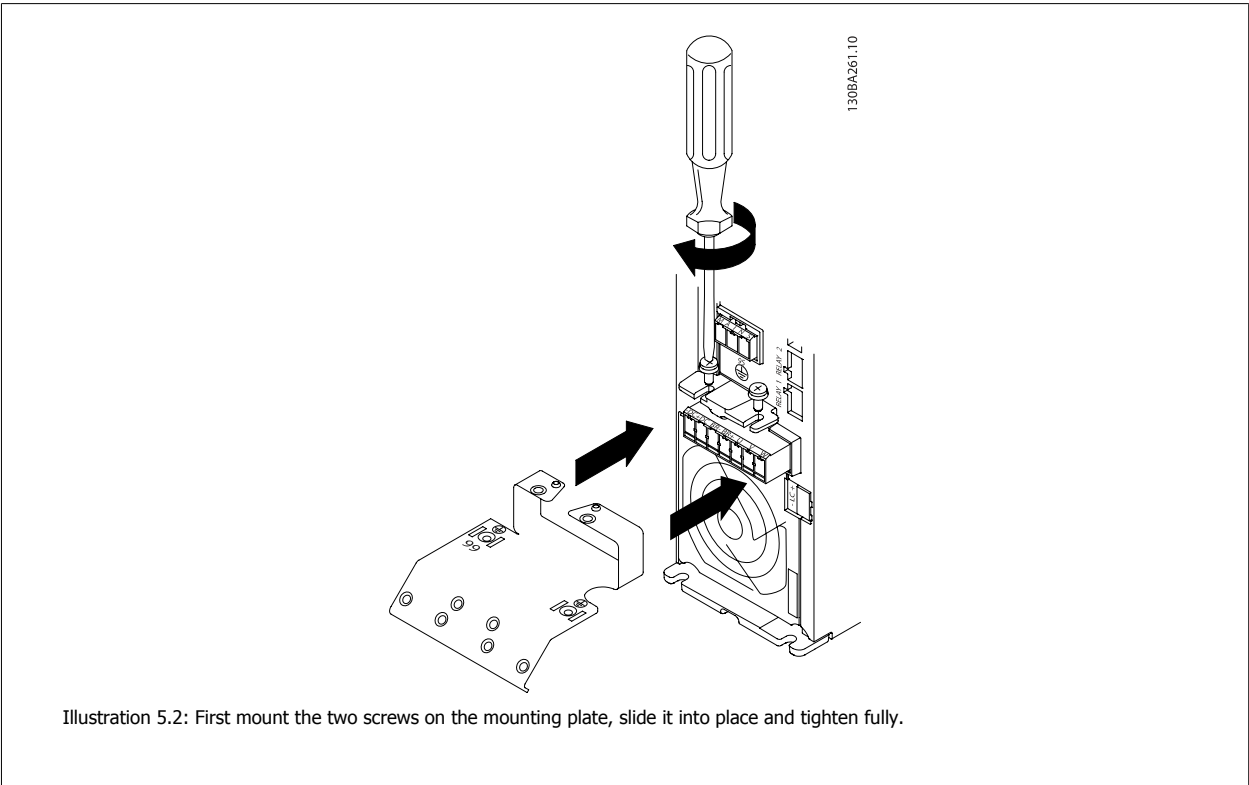

! The earth connection cable cross section must be at least 10 mm² or 2 rated mains wires terminated separately according to *EN 50178/IEC 61800-5-1*.

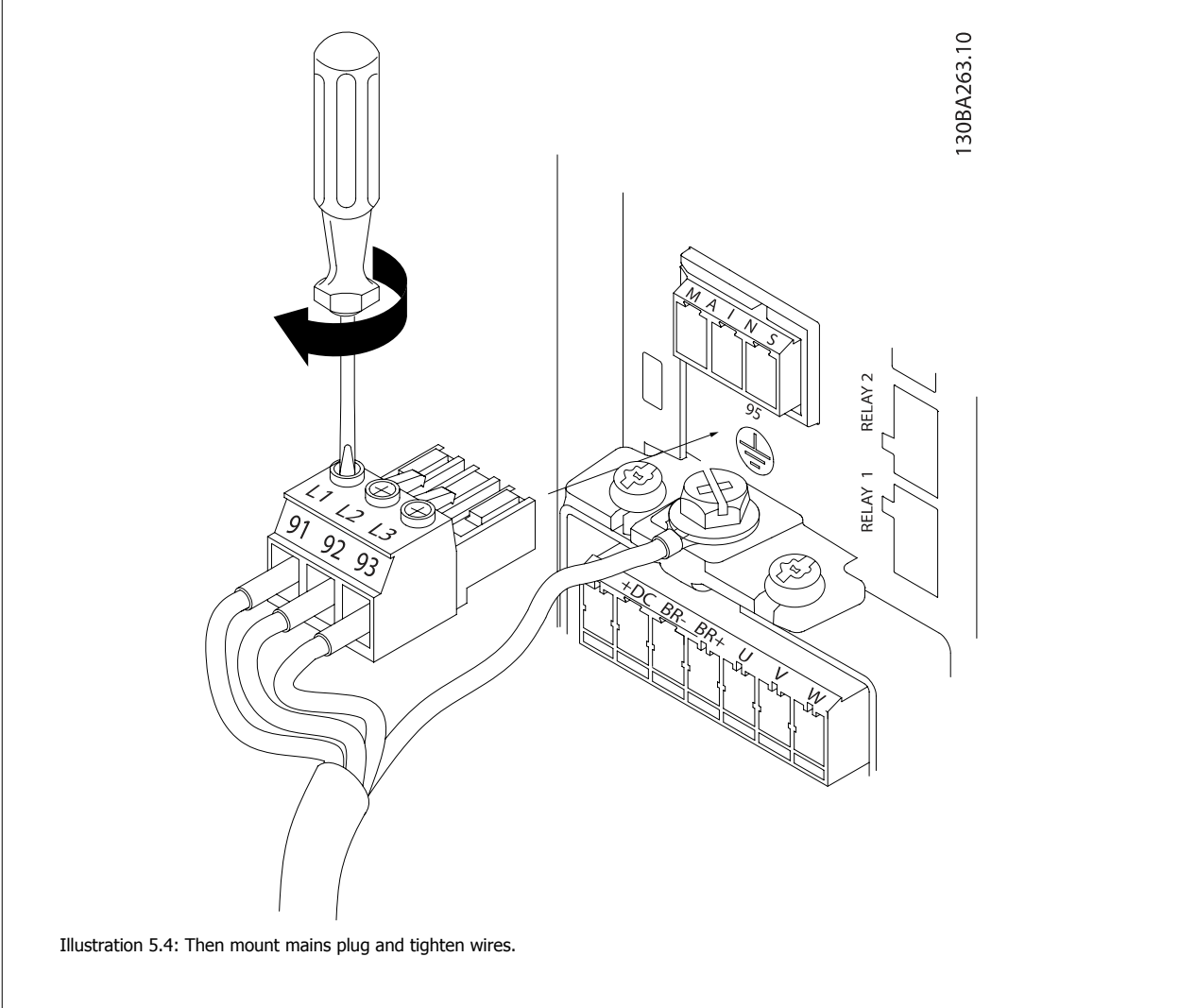

5

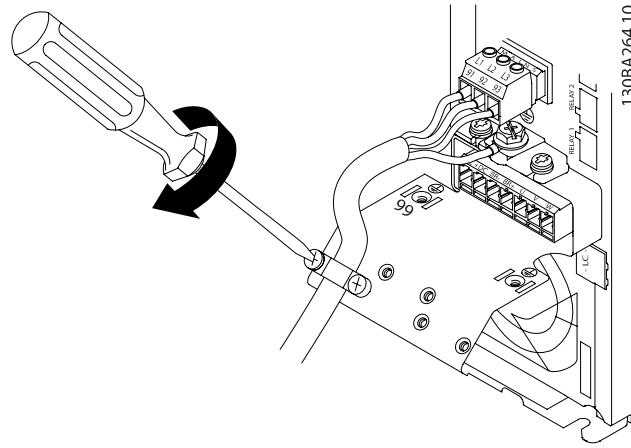
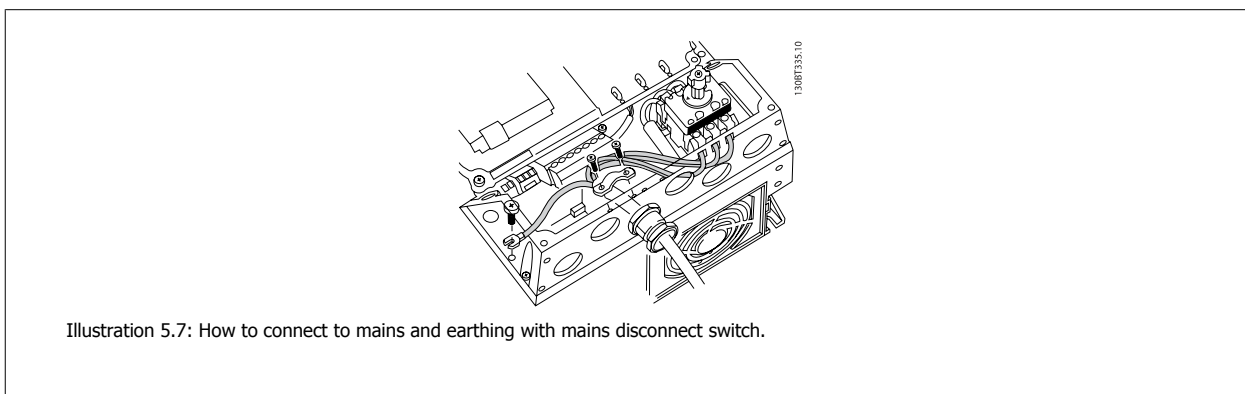
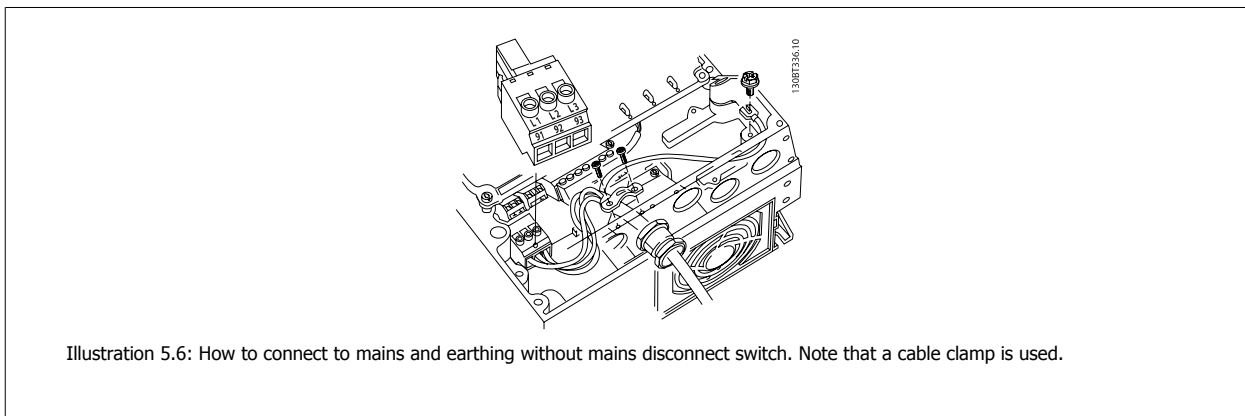

Illustration 5.5: Finally tighten support bracket on mains wires.

NB!

With single phase A3 use L1 and L2 terminals.

5.1.5 Mains Connection for A5



NB!

With single phase A5 use L1 and L2 terminals.

5.1.6 Mains Connection for B1, B2 and B3

5

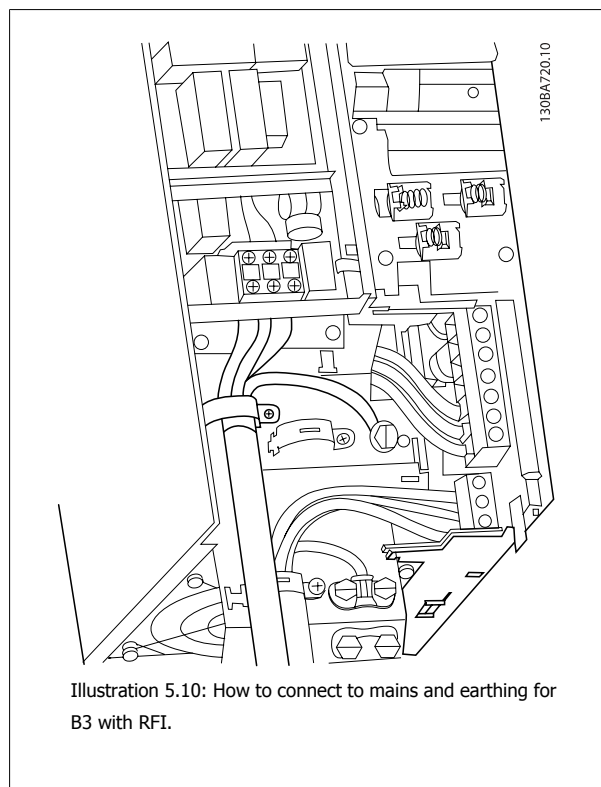
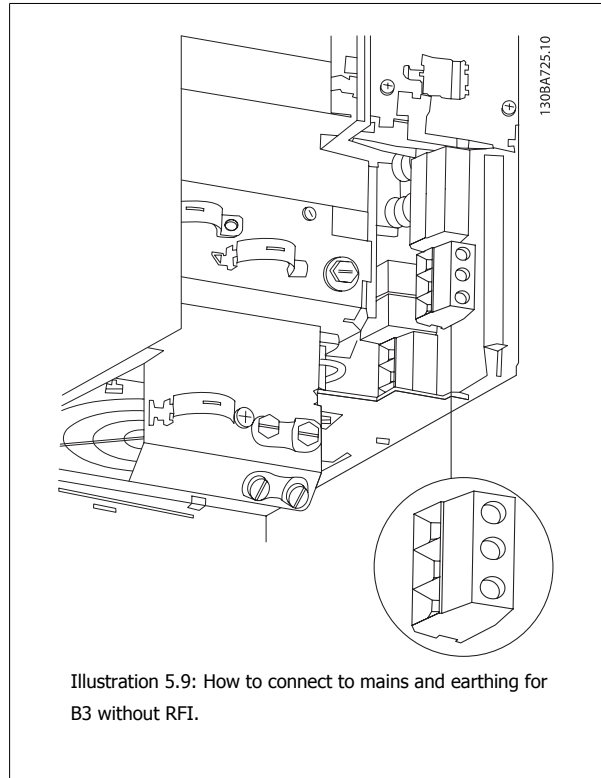
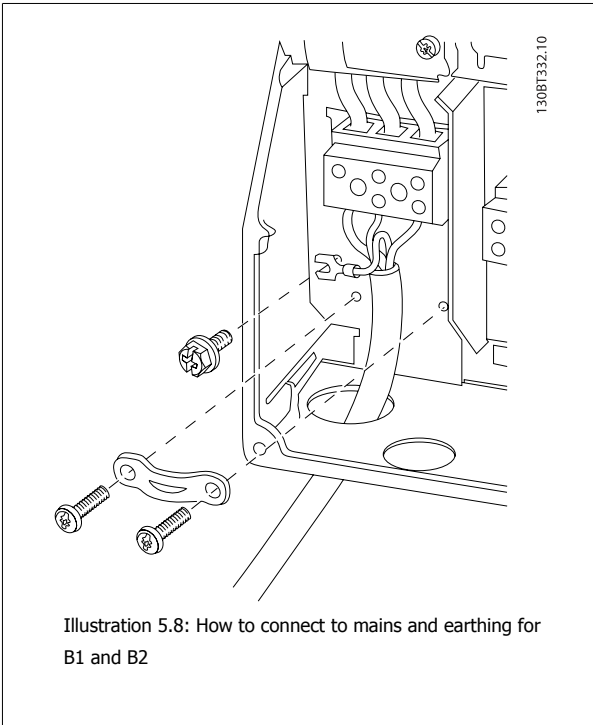

NB!
With single phase B1 use L1 and L2 terminals.

 **NB!**
For correct cable dimensions please see the section *General Specifications* at the back of this manual.

5.1.7 Mains Connection for B4, C1 and C2

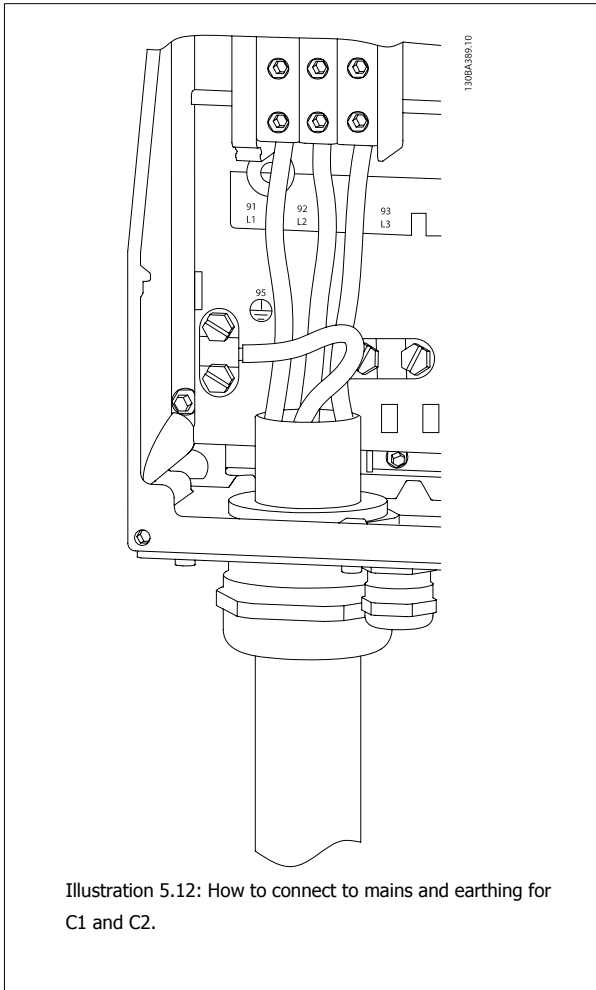
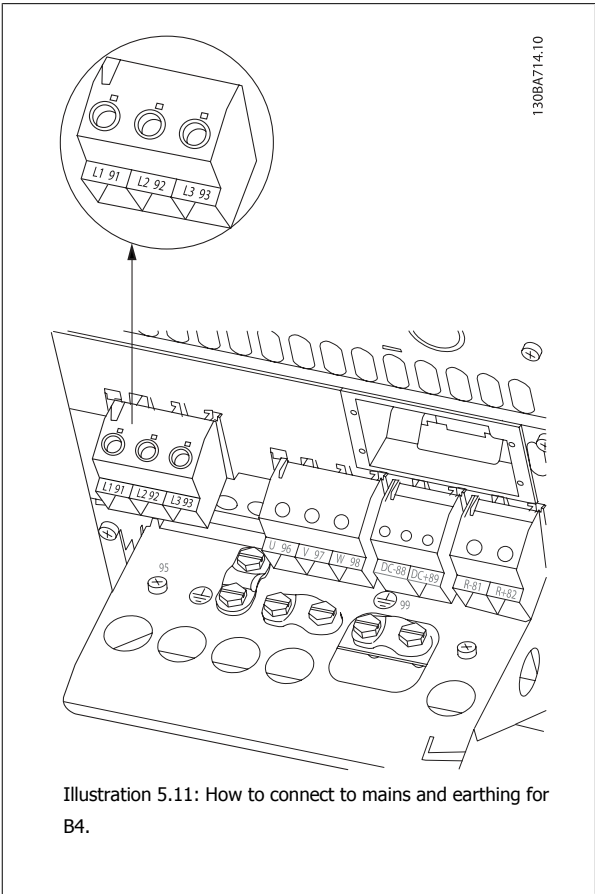

5.1.8 Mains Connection for C3 and C4

5

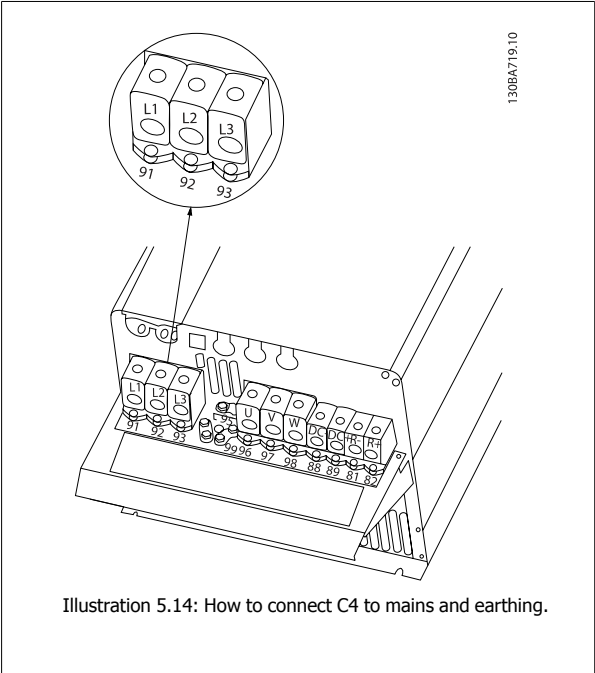
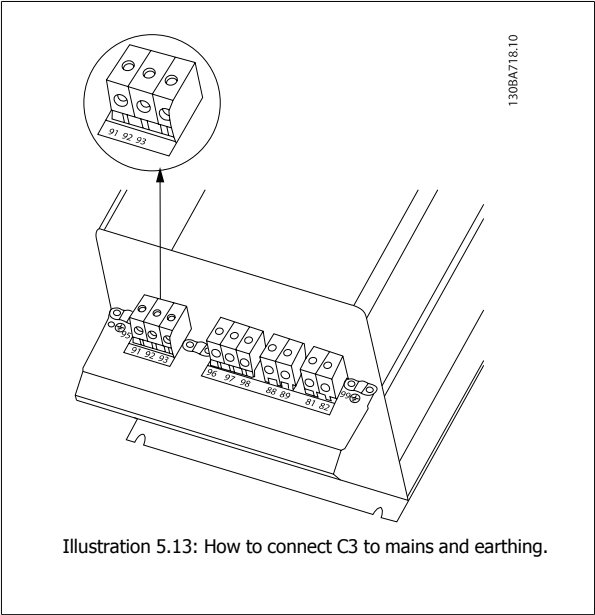

5.1.9 How to Connect Motor - Introduction

See section *General Specifications* for correct dimensioning of motor cable cross-section and length.

- Use a screened/armoured motor cable to comply with EMC emission specifications (or install the cable in metal conduit).
- Keep the motor cable as short as possible to reduce the noise level and leakage currents.
- Connect the motor cable screen/armour to both the decoupling plate of the frequency converter and to the metal of the motor. (Same applies to both ends of metal conduit if used instead of screen.)
- Make the screen connections with the largest possible surface area (cable clamp or by using an EMC cable gland). This is done by using the supplied installation devices in the frequency converter.
- Avoid terminating the screen by twisting the ends (pigtailed), as this will spoil high frequency screening effects.
- If it is necessary to break the continuity of the screen to install a motor isolator or motor relay, the continuity must be maintained with the lowest possible HF impedance.

Cable length and cross-section

The frequency converter has been tested with a given length of cable and a given cross-section of that cable. If the cross-section is increased, the cable capacitance - and thus the leakage current - may increase, and the cable length must be reduced correspondingly.

Switching frequency

When frequency converters are used together with sine wave filters to reduce the acoustic noise from a motor, the switching frequency must be set according to the sine wave filter instruction in par. 14-01 *Switching Frequency*.

Precautions while using Aluminium conductors

Aluminium conductors are not recommended for cable cross sections below 35 mm². Terminals can accept aluminium conductors but the conductor surface has to be clean and the oxidation must be removed and sealed by neutral acid free Vaseline grease before the conductor is connected. Furthermore, the terminal screw must be retightened after two days due to the softness of the aluminium. It is crucial to ensure the connection makes a gas tight joint, otherwise the aluminium surface will oxidize again.

All types of three-phase asynchronous standard motors can be connected to the frequency converter. Normally, small motors are star-connected (230/400 V, D/Y). Large motors are delta-connected (400/690 V, D/Y). Refer to the motor name plate for correct connection mode and voltage.

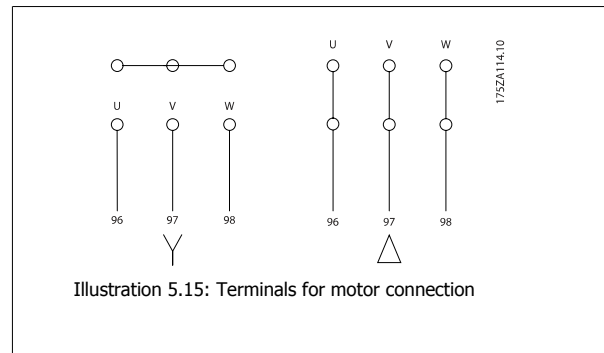

NB!
In motors without phase insulation paper or other insulation reinforcement suitable for operation with voltage supply (such as a frequency converter), fit a sine-wave filter on the output of the frequency converter. (Motors that comply with IEC 60034-17 do not require a Sine-wave filter).

No.	96	97	98	Motor voltage 0-100% of mains voltage.
	U	V	W	3 cables out of motor
	U1	V1	W1	6 cables out of motor, Delta-connected
	W2	U2	V2	
	U1	V1	W1	6 cables out of motor, Star-connected
				U2, V2, W2 to be interconnected separately (optional terminal block)
No.	99			Earth connection
	PE			

Table 5.3: 3 and 6 cable motor connection.

Enclosure:	A2 (IP 20/IP 21)	A3 (IP 20/IP 21)	A5 (IP 55/IP 66)	B1 (IP 21/IP 55/ IP 66)	B2 (IP 21/IP 55/ IP 66)	B3 (IP 20)	B4 (IP 20)	C1 (IP 21/IP 55/66)	C2 (IP 21/IP 55/66)	C3 (IP 20)	C4 (IP 20)
											
Motor size (kW):	0.25-3.0 0.37-4.0	3.7 5.5-7.5 1.1-7.5	1.1-3.7 1.1-7.5 1.1-7.5	5.5-11 11-18.5 11-18.5	15 22-30 22-30	5.5-11 11-18.5 11-18.5	15-18.5 22-37 22-37	18.5-30 37-55 37-55	37-45 75-90 75-90	22-30 45-55 45-55	37-45 75-90 75-90
Goto:		5.1.13	5.1.14	5.1.15	5.1.16	5.1.17	5.1.18				

Table 5.4: Motor wiring table.

5.1.11 Motor Connection for A2 and A3

Follow these drawings step by step for connecting the motor to the frequency converter.

5

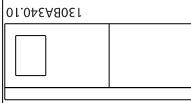
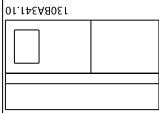
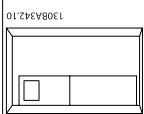
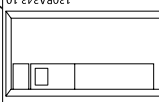
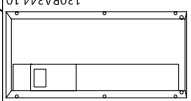
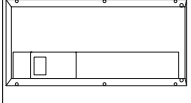
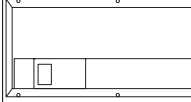
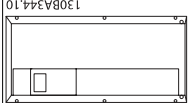
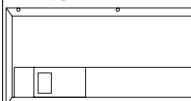
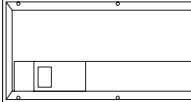
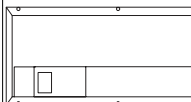
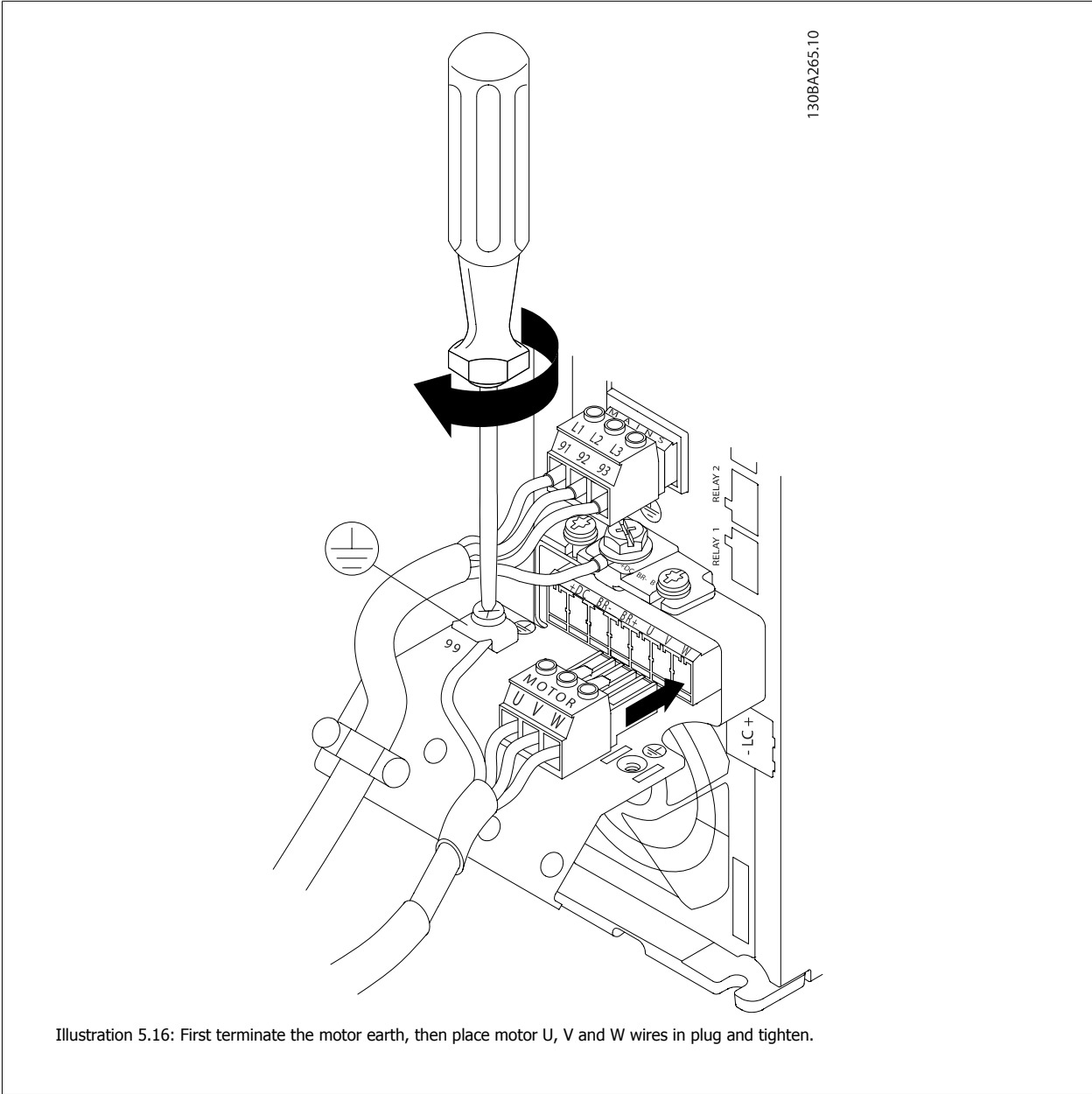

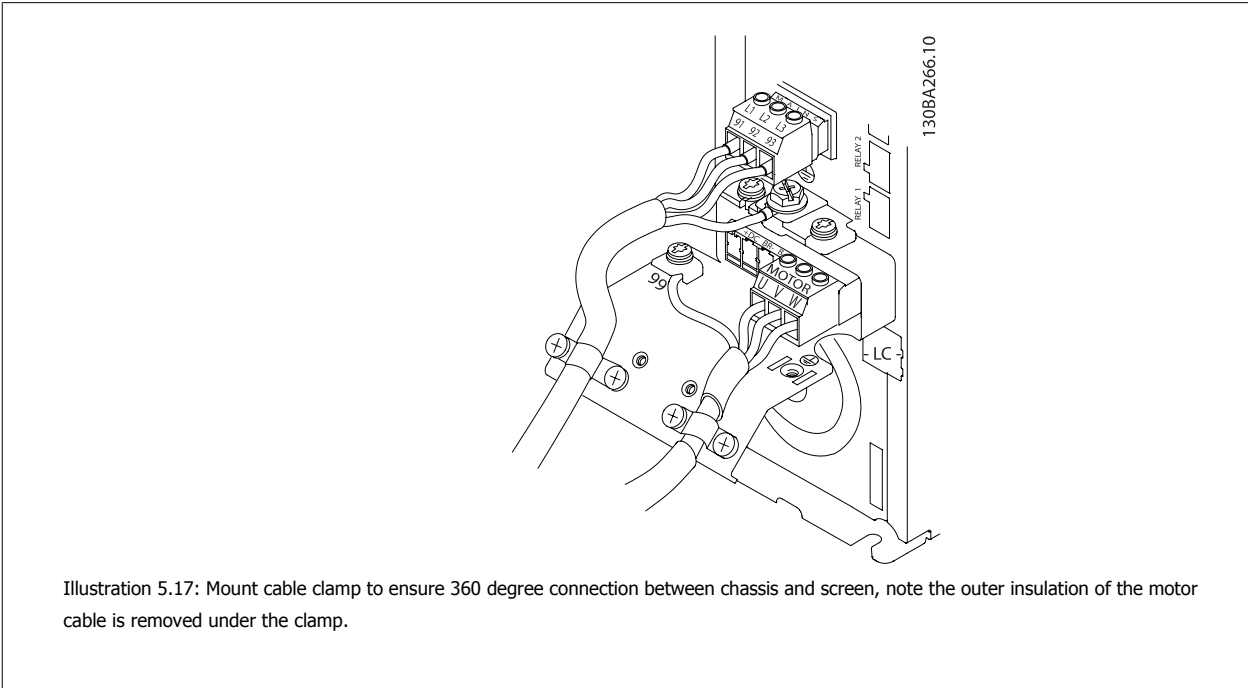

5.1.12 Motor Connection for A5

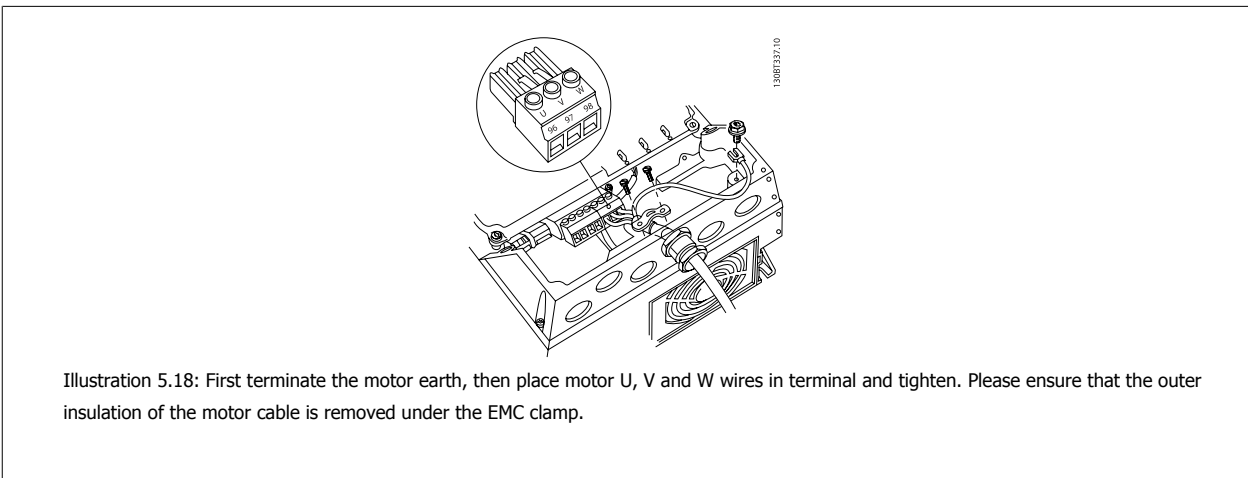

5.1.13 Motor Connection for B1 and B2

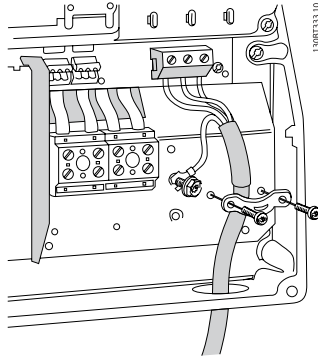

Illustration 5.19: First terminate the motor earth, then Place motor U, V and W wires in terminal and tighten. Please ensure that the outer insulation of the motor cable is removed under the EMC clamp.

5

5.1.14 Motor Connection for B3 and B4

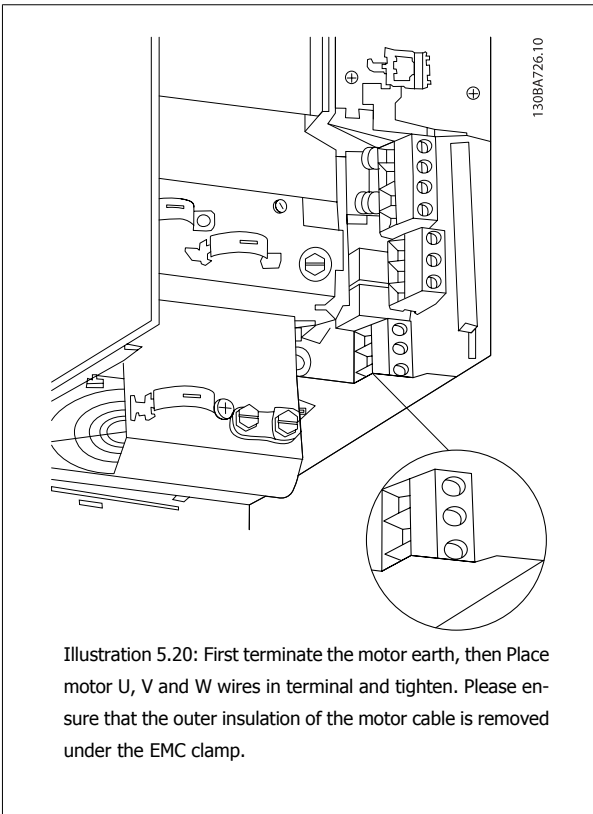

Illustration 5.20: First terminate the motor earth, then Place motor U, V and W wires in terminal and tighten. Please ensure that the outer insulation of the motor cable is removed under the EMC clamp.

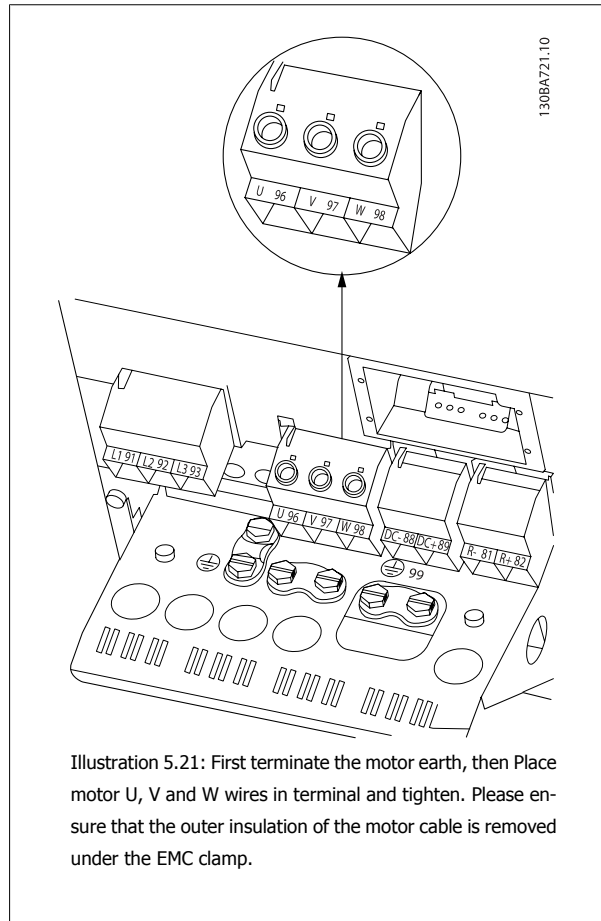
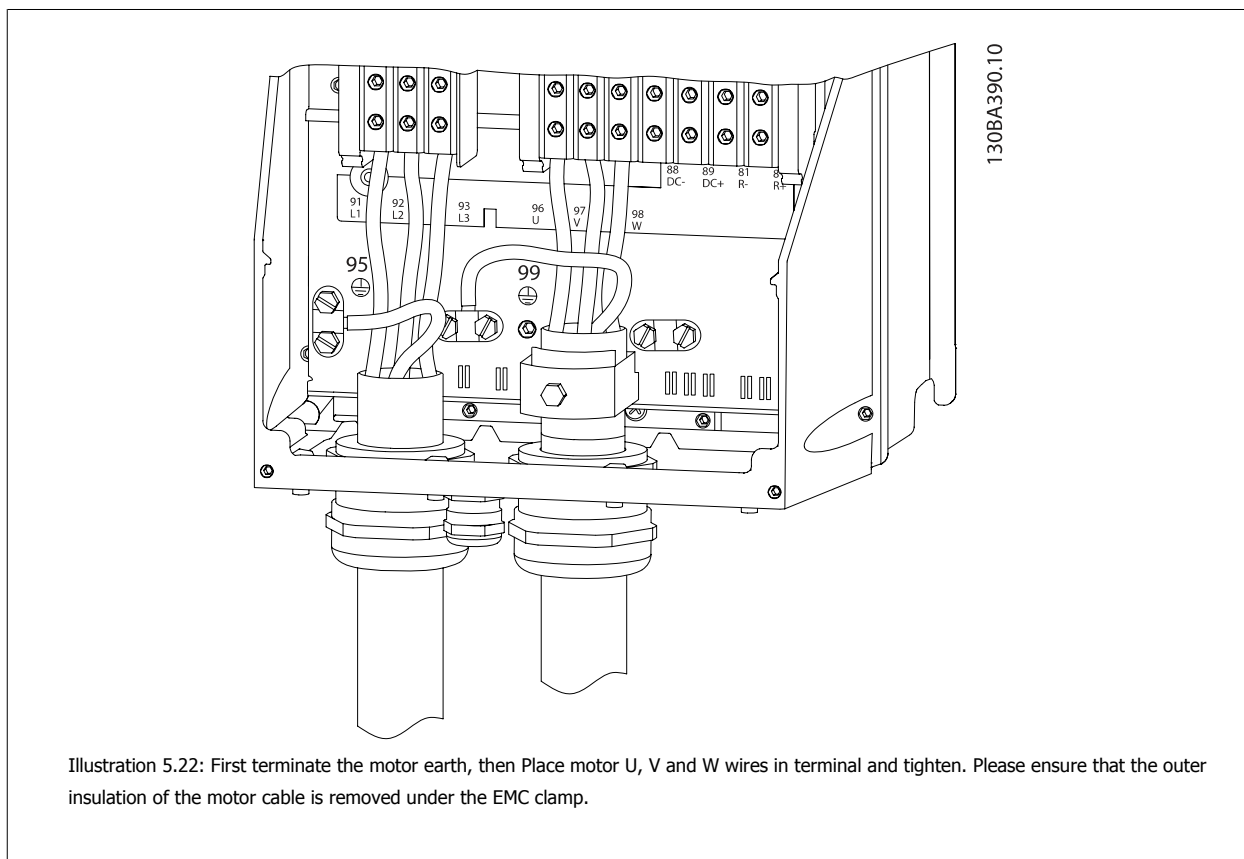

Illustration 5.21: First terminate the motor earth, then Place motor U, V and W wires in terminal and tighten. Please ensure that the outer insulation of the motor cable is removed under the EMC clamp.

5.1.15 Motor Connection for C1 and C2



5.1.16 Motor Connection for C3 and C4

5

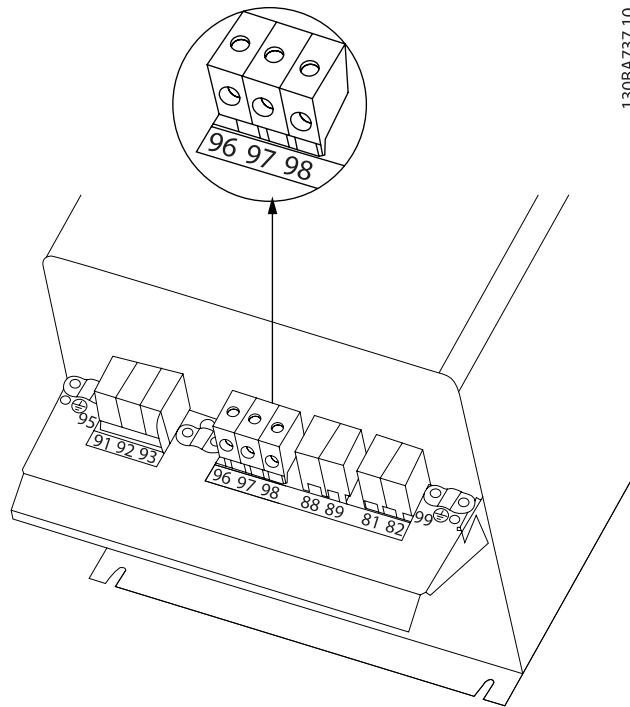
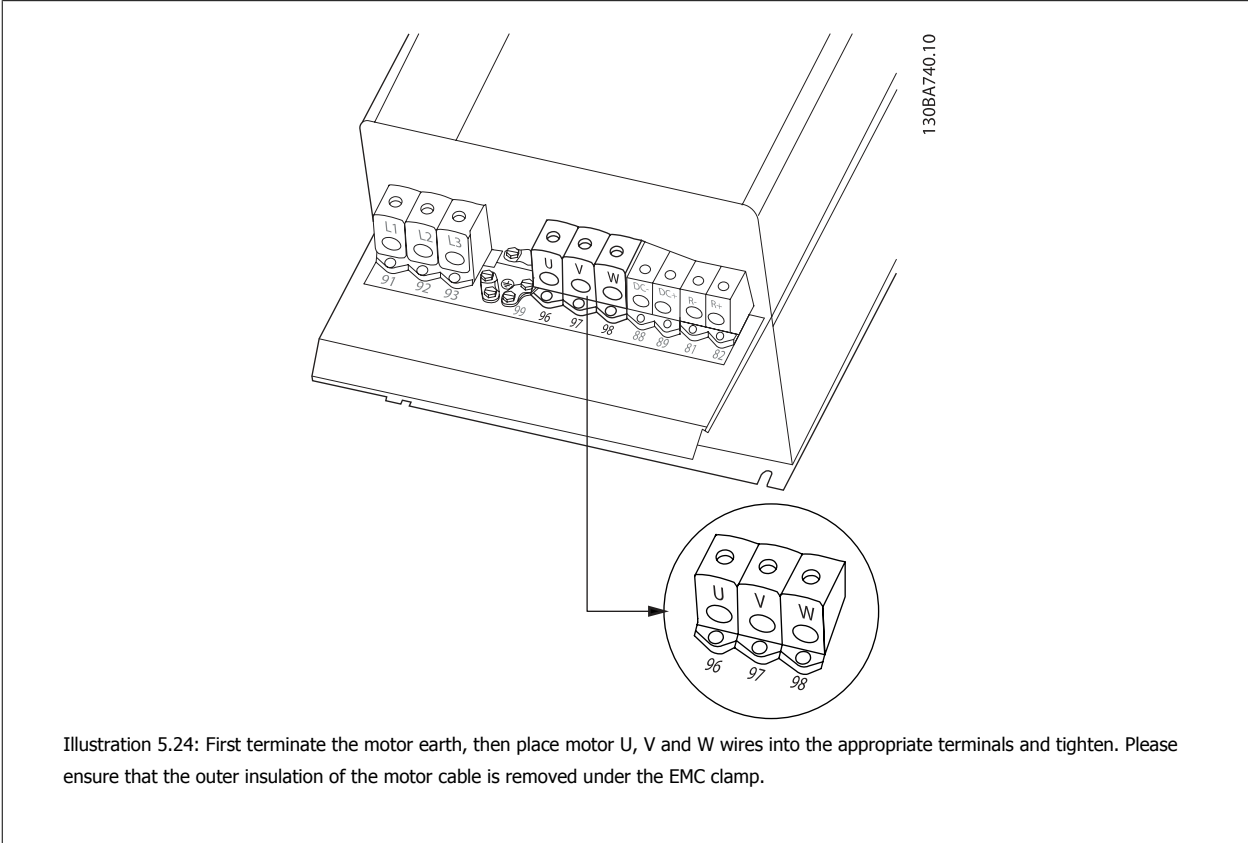

Illustration 5.23: First terminate the motor earth, then place motor U, V and W wires into the appropriate terminals and tighten. Please ensure that the outer insulation of the motor cable is removed under the EMC clamp.



5.1.17 DC Bus Connection

The DC bus terminal is used for DC back-up, with the intermediate circuit being supplied from an external source.

Terminal numbers used: 88, 89

5

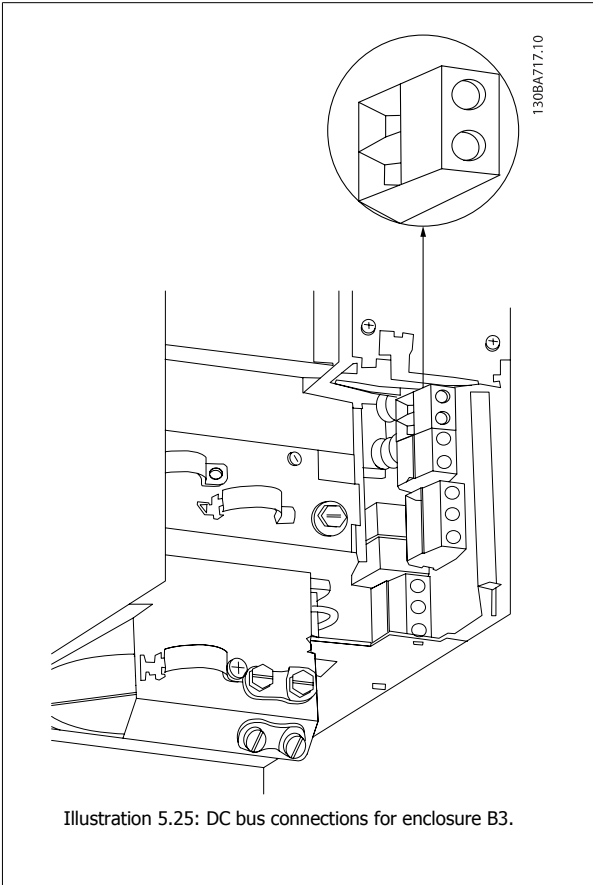

Illustration 5.25: DC bus connections for enclosure B3.

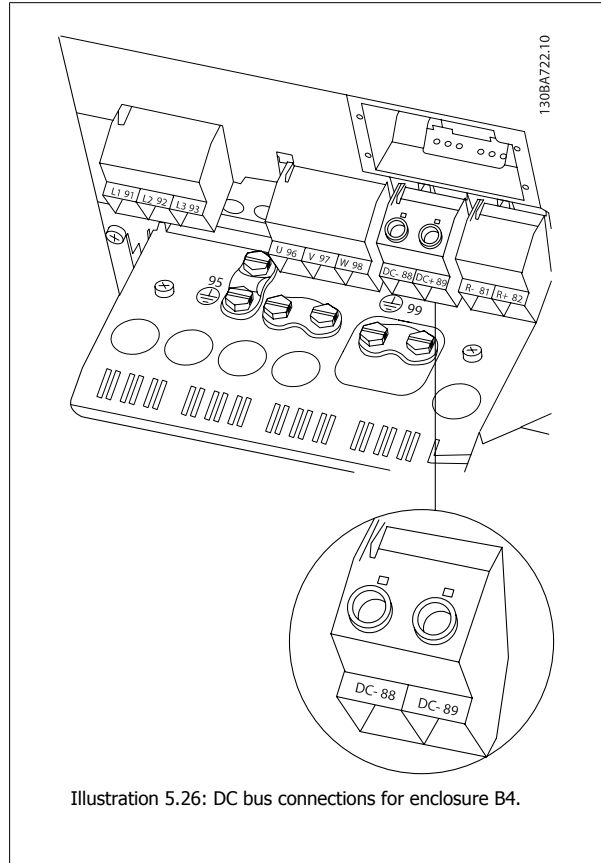

Illustration 5.26: DC bus connections for enclosure B4.

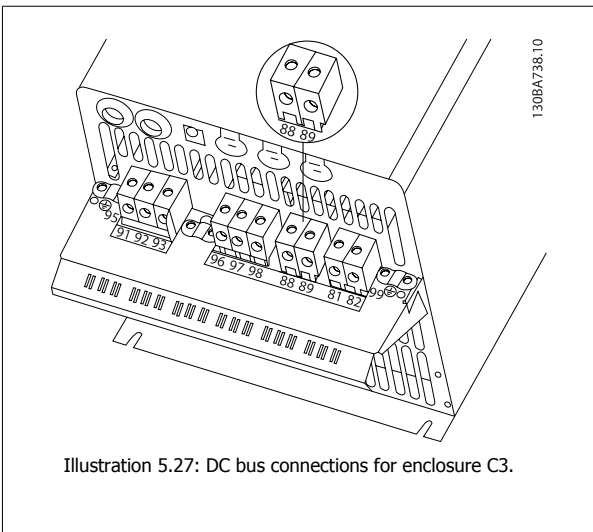

Illustration 5.27: DC bus connections for enclosure C3.

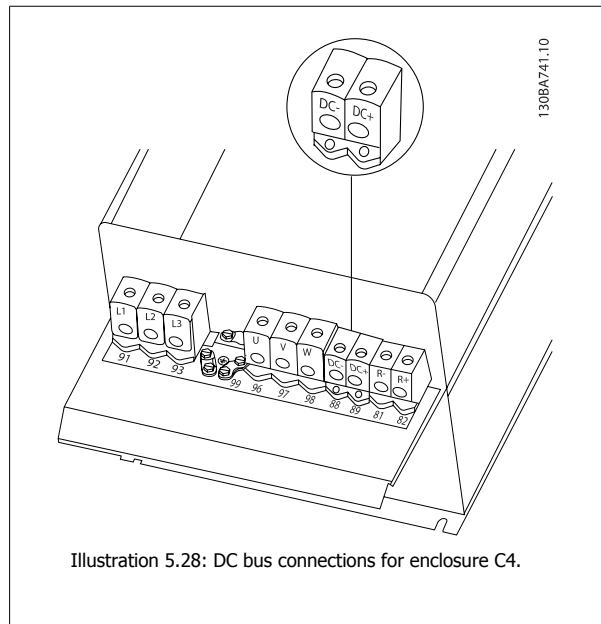



Illustration 5.28: DC bus connections for enclosure C4.

Please contact [Danfoss](#) if you require further information.

5.1.18 Brake Connection Option

The connection cable to the brake resistor must be screened/armoured.

Brake resistor		
Terminal number	81	82
Terminals	R-	R+

 **NB!**
Dynamic brake calls for extra equipment and safety considerations. For further information, please contact .

1. Use cable clamps to connect the screen to the metal cabinet of the frequency converter and to the decoupling plate of the brake resistor.
2. Dimension the cross-section of the brake cable to match the brake current.

 **NB!**
Voltages up to 975 V DC (@ 600 V AC) may occur between the terminals.

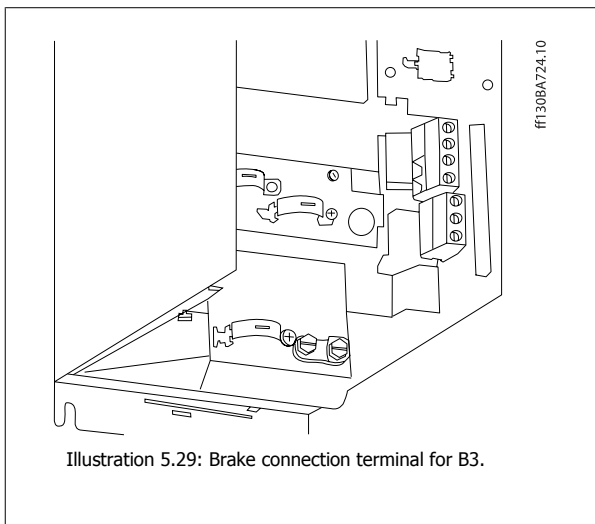

Illustration 5.29: Brake connection terminal for B3.

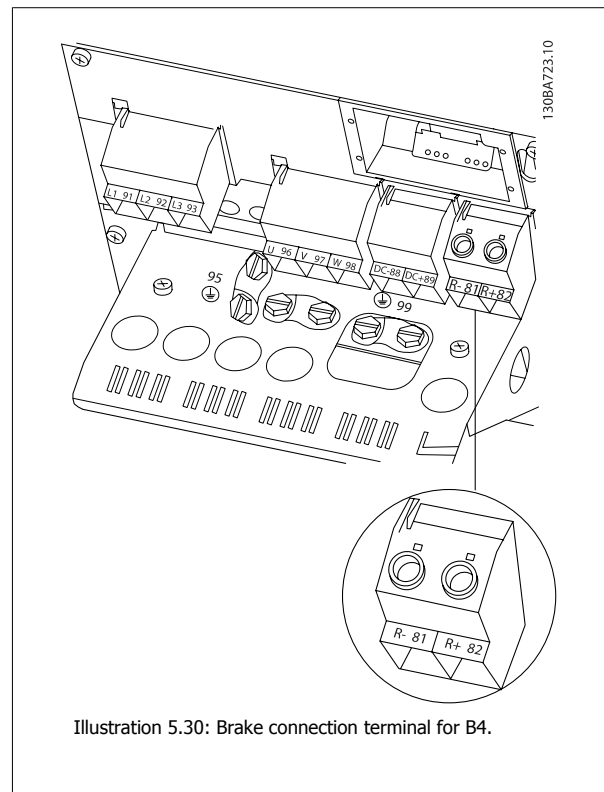

Illustration 5.30: Brake connection terminal for B4.

5

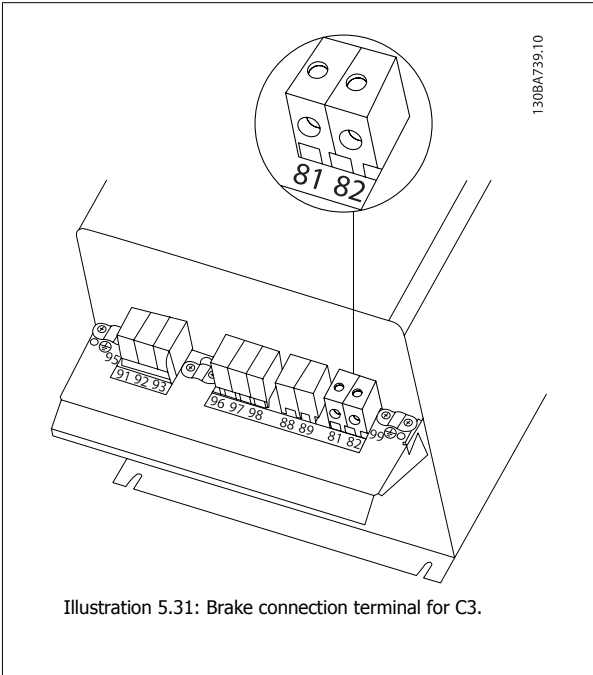

Illustration 5.31: Brake connection terminal for C3.

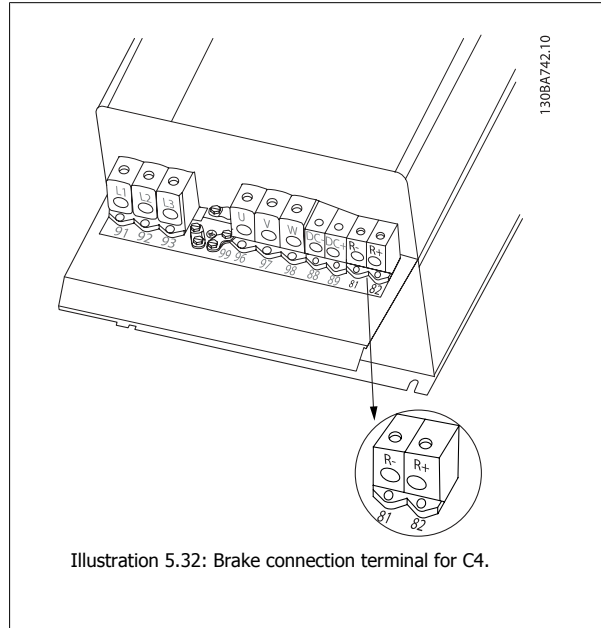

Illustration 5.32: Brake connection terminal for C4.



NB!

If a short circuit in the brake IGBT occurs, prevent power dissipation in the brake resistor by using a mains switch or contactor to disconnect the mains for the frequency converter. Only the frequency converter shall control the contactor.



NB!

Place the brake resistor in an environment free of fire risk and ensure that no external objects can fall into the brake resistor through ventilation slots.
Do not cover ventilation slots and grids.

5.1.19 Relay Connection

To set relay output, see par. group 5-4* Relays.

No.	01 - 02	make (normally open)
	01 - 03	break (normally closed)
	04 - 05	make (normally open)
	04 - 06	break (normally closed)

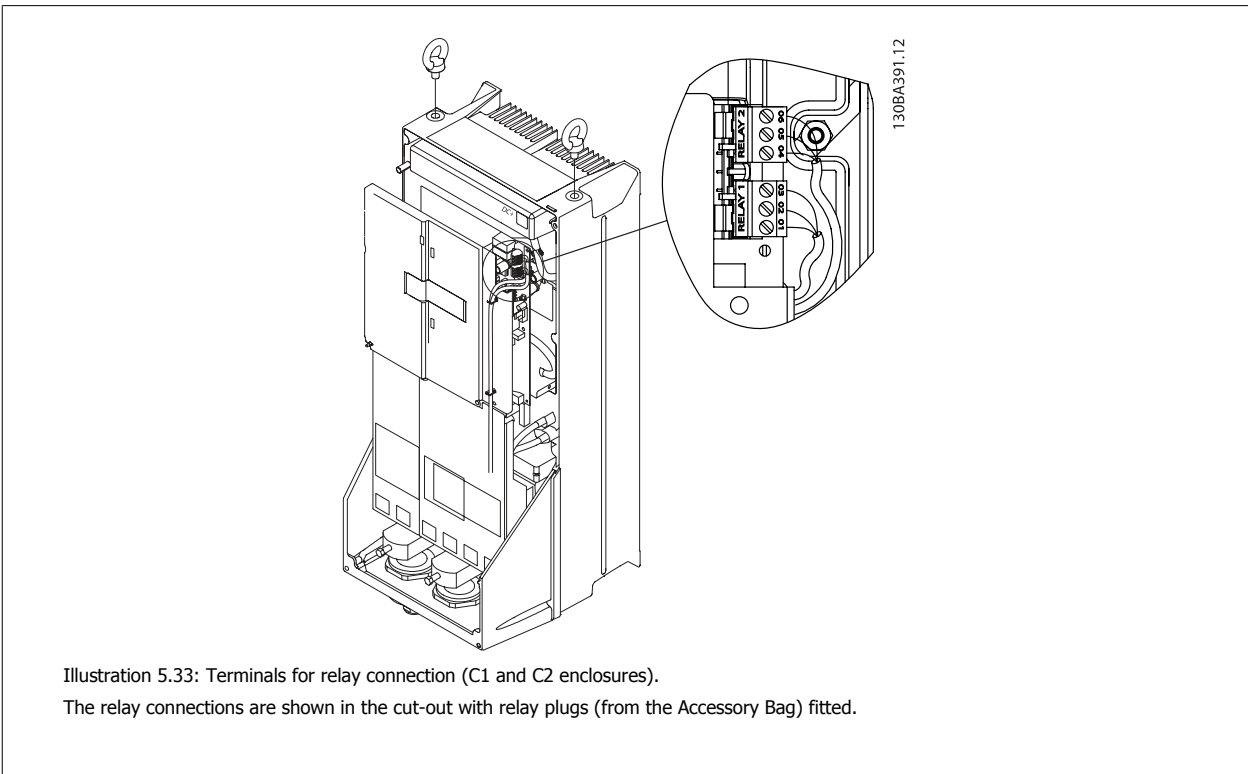
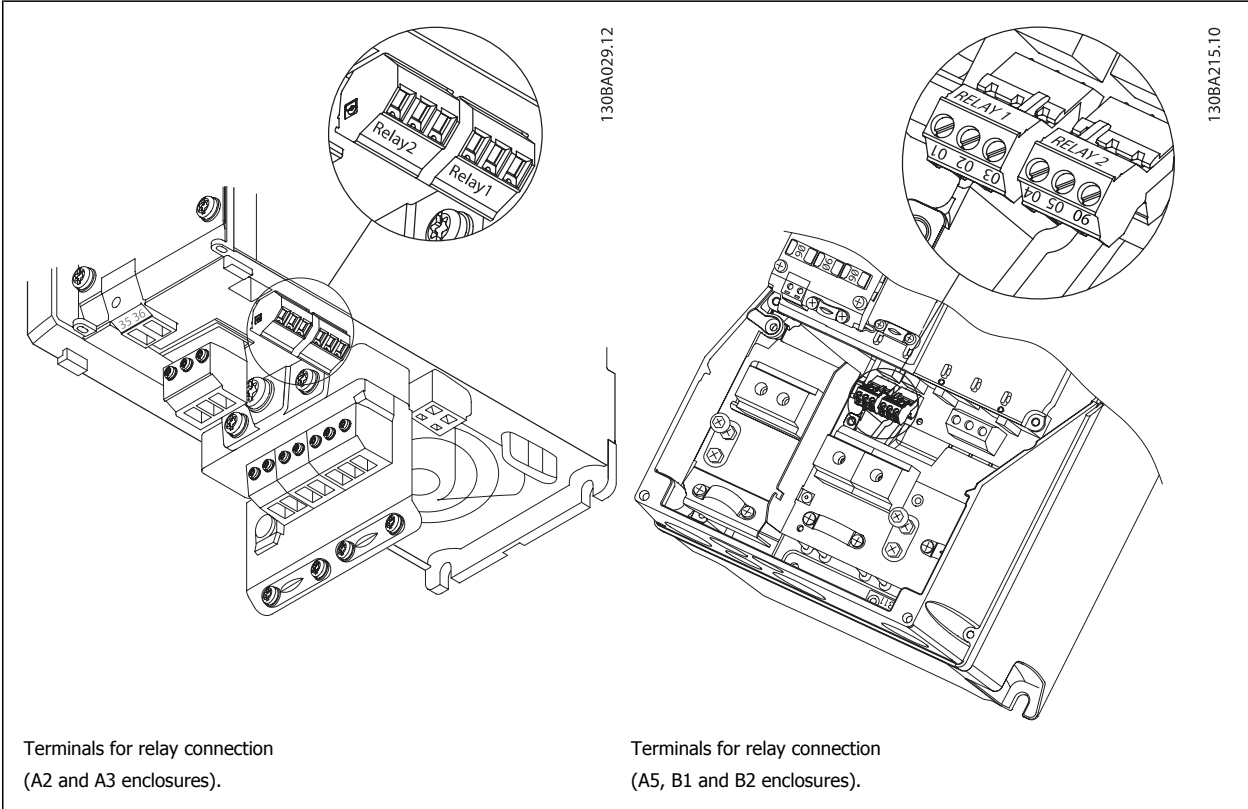

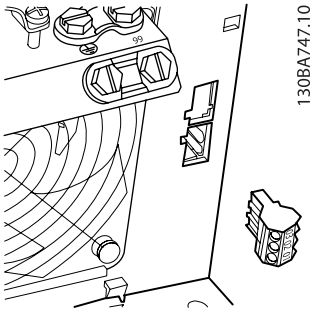

Illustration 5.34: Terminals for relay connections for B3. Only one relay input is fitted from the factory. When the second relay is needed remove knock-out.

5

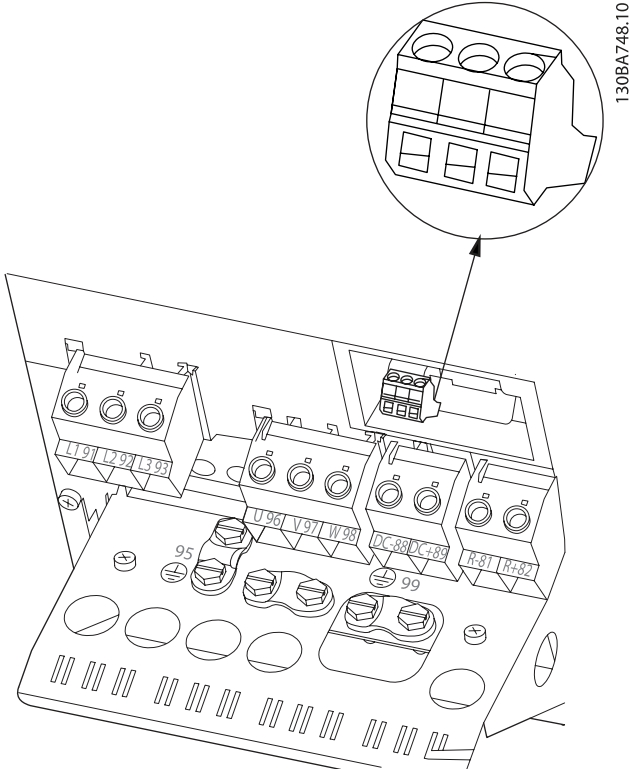
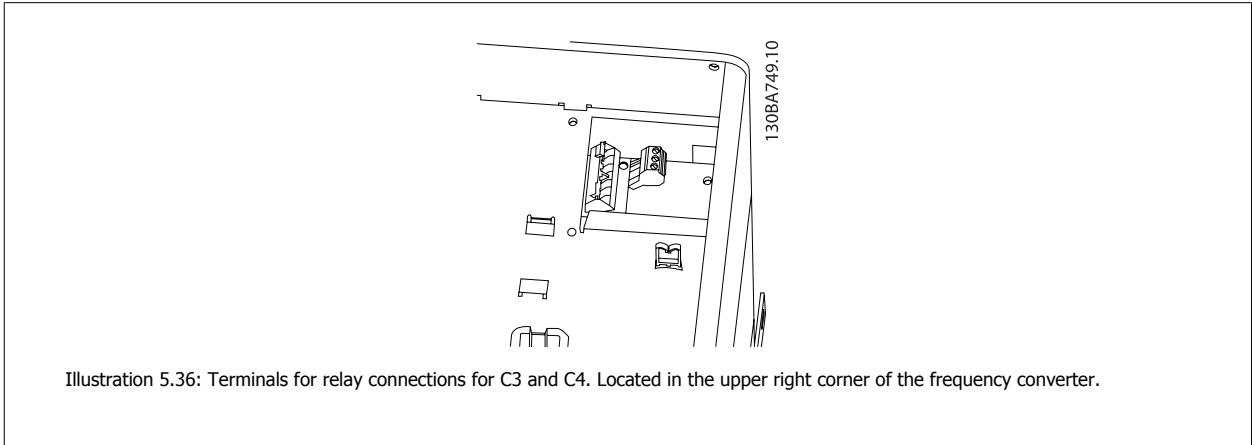

Illustration 5.35: Terminals for relay connections for B4.



5.1.20 Relay Output

Relay 1

- Terminal 01: common
- Terminal 02: normal open 240 V AC
- Terminal 03: normal closed 240 V AC

Relay 1 and relay 2 are programmed in par. 5-40 *Function Relay*, par. 5-41 *On Delay, Relay*, and par. 5-42 *Off Delay, Relay*.

Additional relay outputs by using option module MCB 105.

Relay 2

- Terminal 04: common
- Terminal 05: normal open 400 V AC
- Terminal 06: normal closed 240 V AC

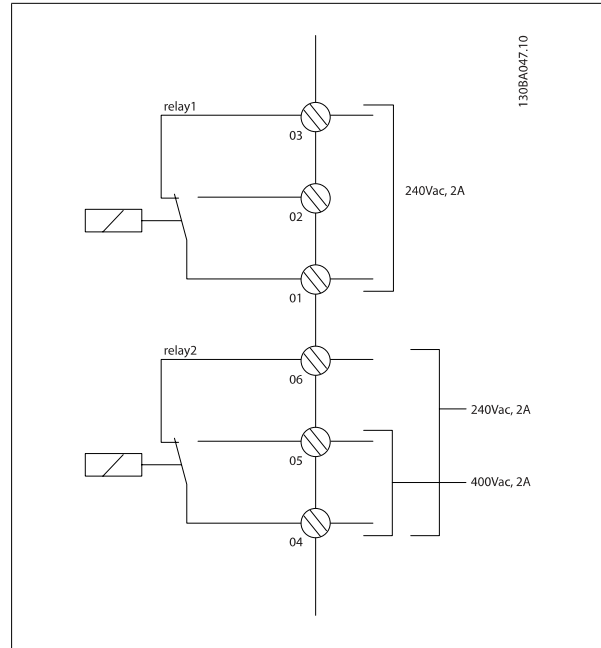

5.1.21 Wiring Example and Testing

The following section describes how to terminate control wires and how to access them. For an explanation of the function, programming and wiring of the control terminals, please see chapter, *How to programme the frequency converter*.

5.1.22 Access to Control Terminals

All terminals to the control cables are located underneath the terminal cover on the front of the frequency converter. Remove the terminal cover with a screwdriver.

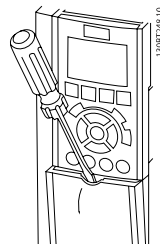

Illustration 5.37: Access to control terminals for A2, A3, B3, B4, C3 and C4 enclosures

Remove front-cover to access control terminals. When replacing the front-cover, please ensure proper fastening by applying a torque of 2 Nm.

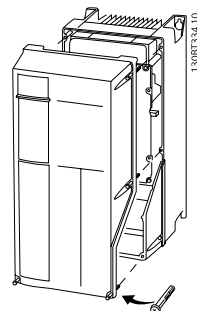
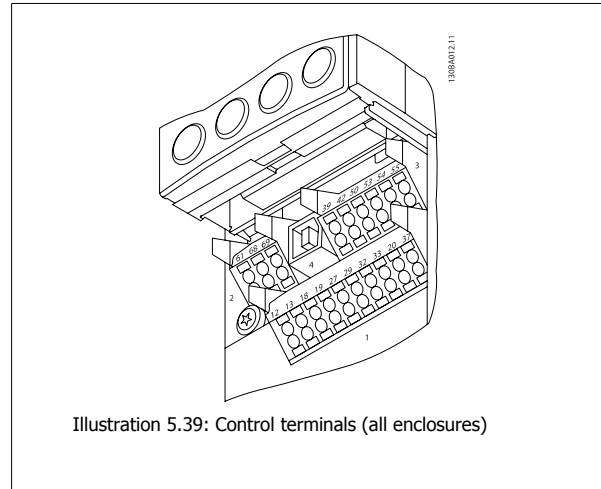

Illustration 5.38: Access to control terminals for A5, B1, B2, C1 and C2 enclosures

5.1.23 Control Terminals

Drawing reference numbers:

1. 10-pole plug digital I/O.
2. 3-pole plug RS-485 Bus.
3. 6-pole analog I/O.
4. USB connection.



5.1.24 Control Cable Clamp

1. Use a clamp from the accessory bag to connect screen to frequency converter decoupling plate for control cables.

See section entitled *Earthing of Screened/Armoured Control Cables* for the correct termination of control cables.

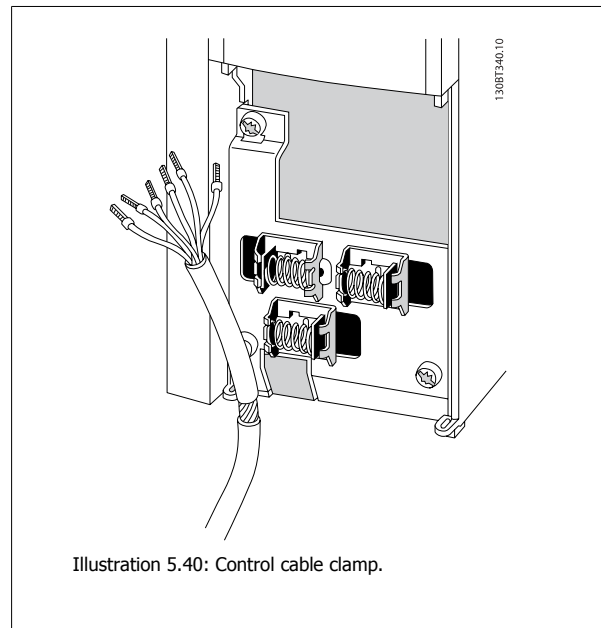

5.1.25 Electrical Installation and Control Cables

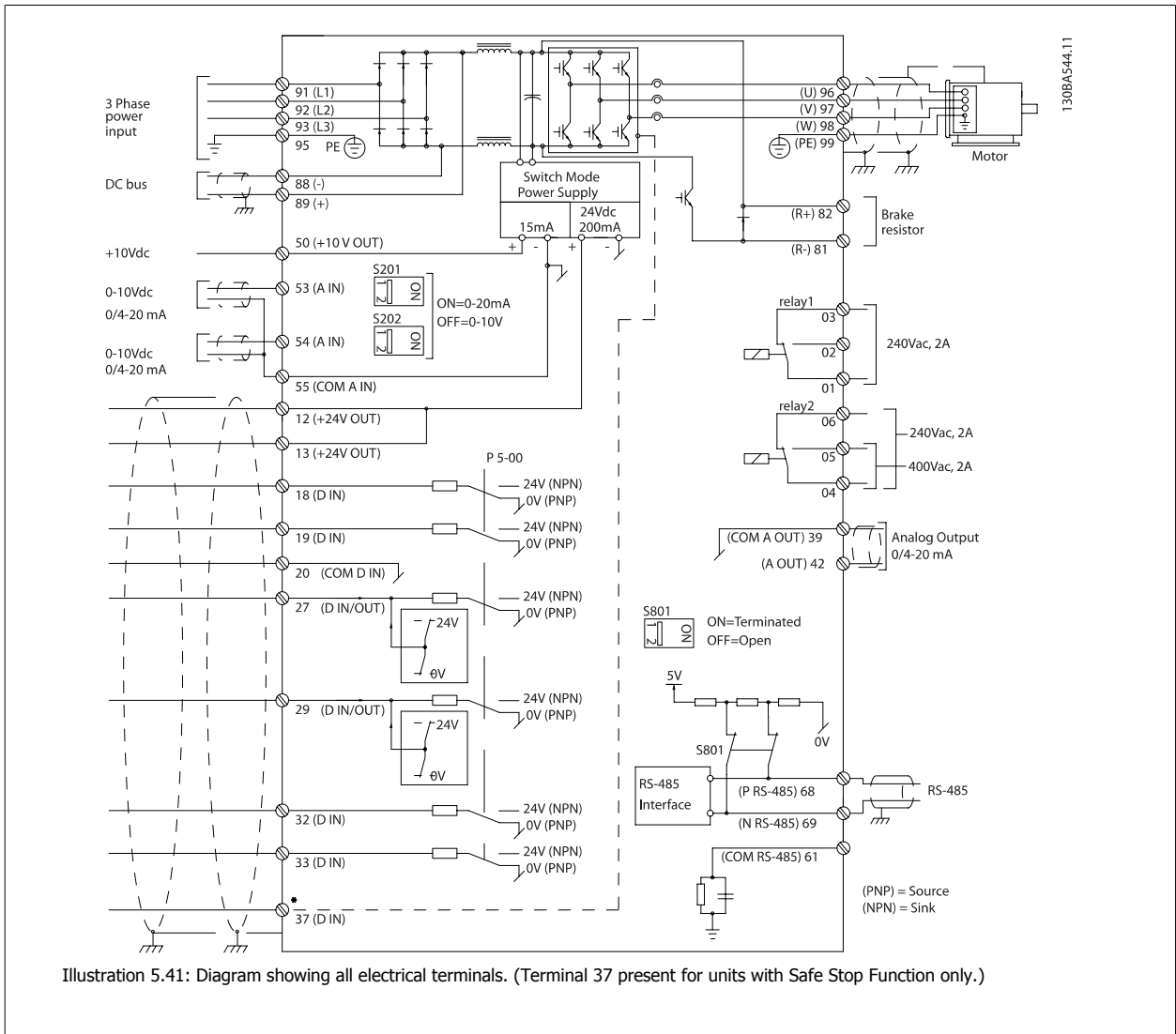

Terminal number	Terminal description	Parameter number	Factory default
1+2+3	Terminal 1+2+3-Relay1	5-40	No operation
4+5+6	Terminal 4+5+6-Relay2	5-40	No operation
12	Terminal 12 Supply	-	+24 V DC
13	Terminal 13 Supply	-	+24 V DC
18	Terminal 18 Digital Input	5-10	Start
19	Terminal 19 Digital Input	5-11	No operation
20	Terminal 20	-	Common
27	Terminal 27 Digital Input/Output	5-12/5-30	Coast inverse
29	Terminal 29 Digital Input/Output	5-13/5-31	Jog
32	Terminal 32 Digital Input	5-14	No operation
33	Terminal 33 Digital Input	5-15	No operation
37	Terminal 37 Digital Input	-	Safe Stop
42	Terminal 42 Analog Output	6-50	Speed 0-HighLim
53	Terminal 53 Analog Input	3-15/6-1*/20-0*	Reference
54	Terminal 54 Analog Input	3-15/6-2*/20-0*	Feedback

Table 5.5: Terminal connections

Very long control cables and analog signals may, in rare cases and depending on installation, result in 50/60 Hz earth loops due to noise from mains supply cables.

If this occurs, break the screen or insert a 100 nF capacitor between screen and chassis.

NB!
The common of digital / analog inputs and outputs should be connected to separate common terminals 20, 39, and 55. This will avoid ground current interference among groups. For example, it avoids switching on digital inputs disturbing analog inputs.

NB!
Control cables must be screened/armoured.

5.1.26 How to Test Motor and Direction of Rotation

Note that unintended motor start can occur, ensure no personnel or equipment is in danger!

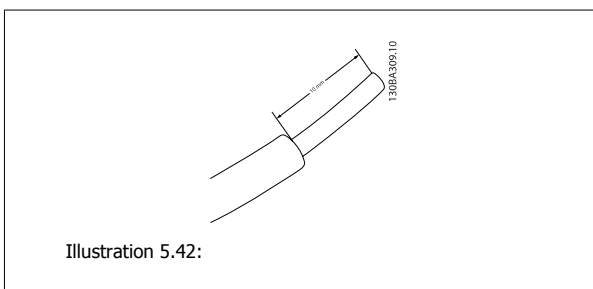

Step 1: First remove the insulation on both ends of a 50 to 70 mm piece of wire.

Please follow these steps to test the motor connection and direction of rotation. Start with no power to the unit.

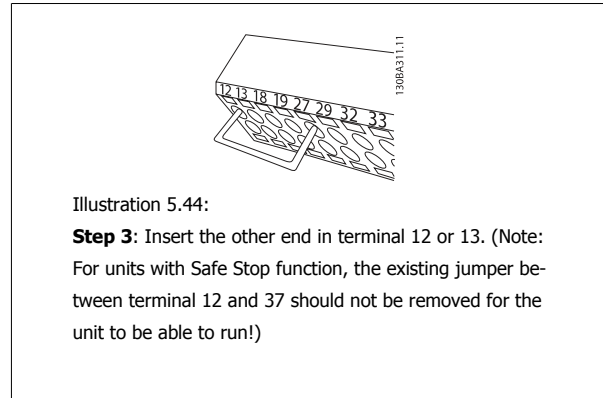
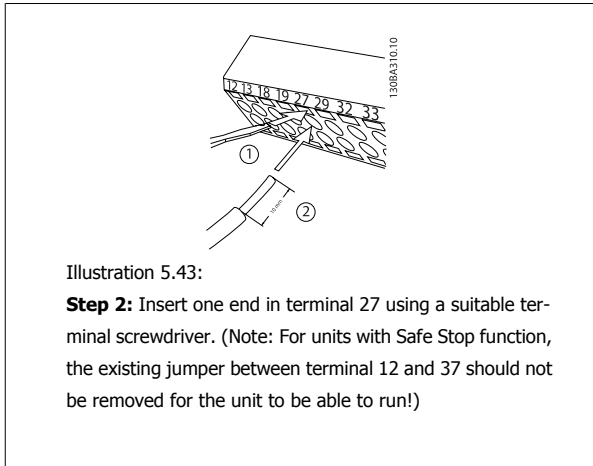

5

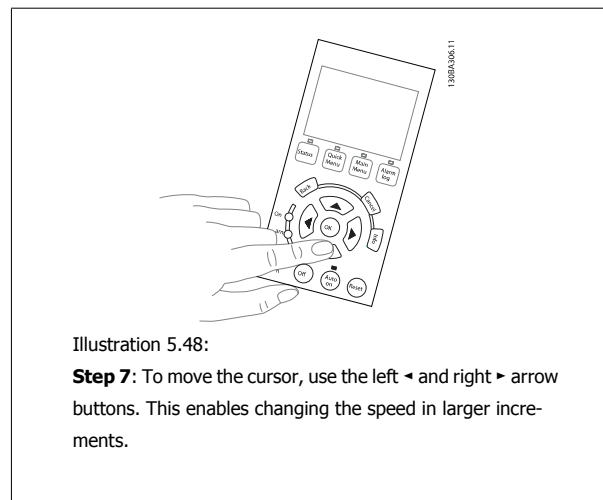
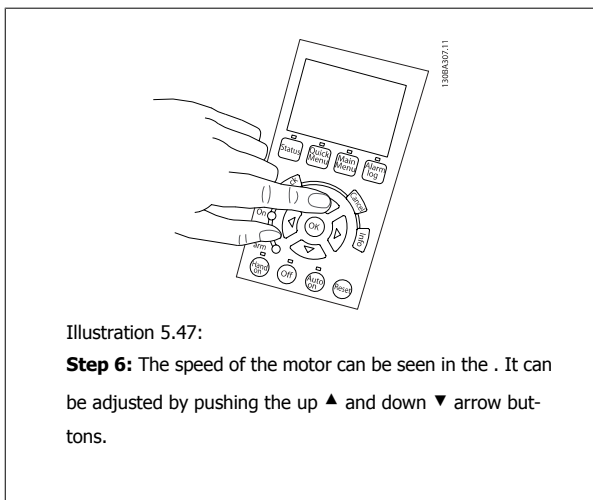
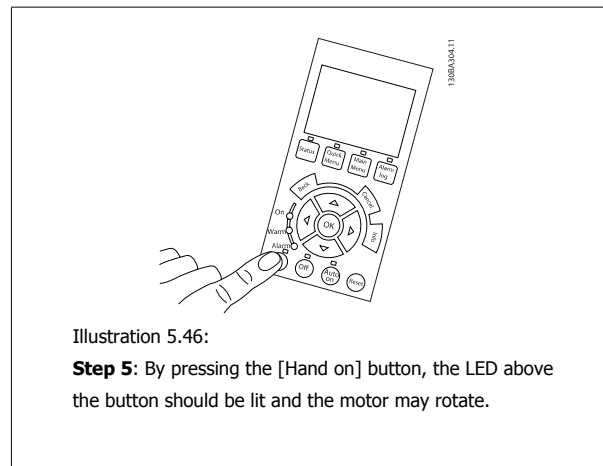
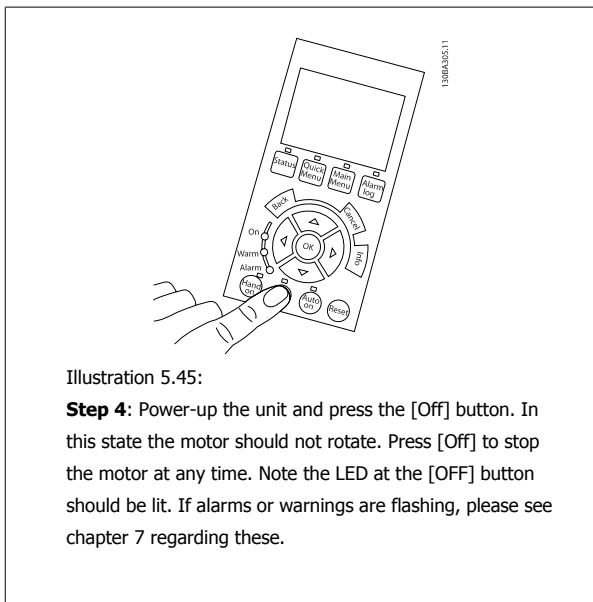

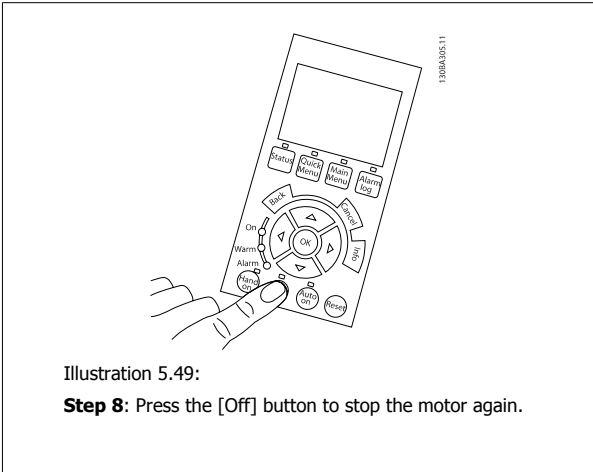

Illustration 5.49:
Step 8: Press the [Off] button to stop the motor again.

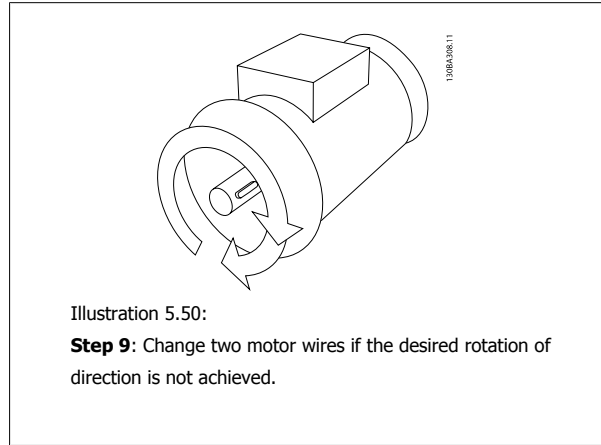

Illustration 5.50:
Step 9: Change two motor wires if the desired rotation of direction is not achieved.

Remove mains power from the frequency converter before changing motor wires.

5.1.27 Switches S201, S202 and S801

Switches S201 (AI 53) and S202 (AI 54) are used to select a current (0-20 mA) or a voltage (0 to 10 V) configuration of the analog input terminals 53 and 54 respectively.

Switch S801 (BUS TER.) can be used to enable termination on the RS-485 port (terminals 68 and 69).

Please note that the switches may be covered by an option, if fitted.

Default setting:

- S201 (AI 53) = OFF (voltage input)
- S202 (AI 54) = OFF (voltage input)
- S801 (Bus termination) = OFF

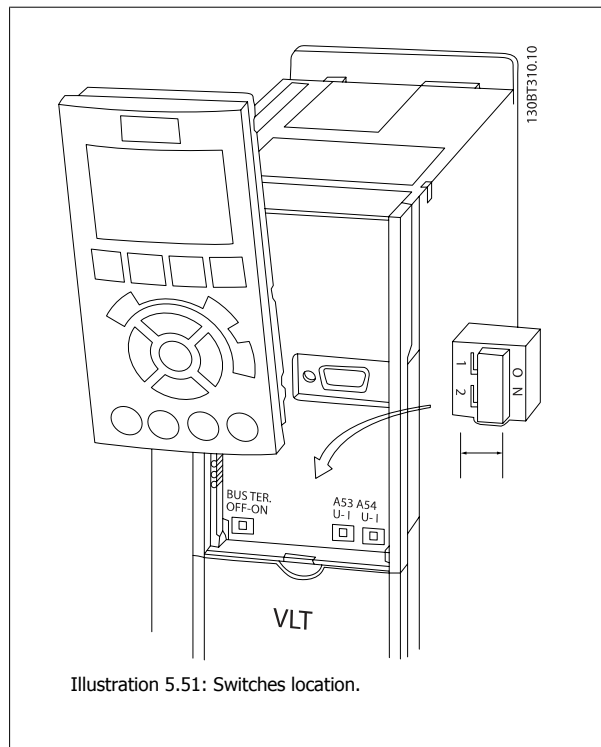

Illustration 5.51: Switches location.

5.2 Final Optimization and Test

To optimize motor shaft performance and optimize the frequency converter for the connected motor and installation, please follow these steps. Ensure that frequency converter and motor are connected, and power is applied to frequency converter.

NB!
Before power up ensure that connected equipment is ready for use.

Step 1. Locate motor name plate

NB!
The motor is either star- (Y) or delta- connected (Δ). This information is located on the motor name plate data.

5

BAUER D 73734 ESSLINGEN				
3-MOTOR NR. 167421 2003				
S/E005A9				
		1,5	KW	
n ₁ 315	/min.	400	Y	Y
n ₂ 1400	/min.	50	Hz	
COS ϕ 0,80		3,6	A	
1,7L				
B	B 65		H/1A	

Illustration 5.52: Motor name plate example

Step 2. Enter motor name plate data in following parameter list.

To access list first press [QUICK MENU] key then select "Q2 Quick Setup".

1.	Motor Power [kW] or Motor Power [HP]	par. 1-20 par. 1-21
2.	Motor Voltage	par. 1-22
3.	Motor Frequency	par. 1-23
4.	Motor Current	par. 1-24
5.	Motor Nominal Speed	par. 1-25

Table 5.6: Motor related parameters

Step 3. Activate Automatic Motor Adaptation (AMA)

Performing AMA ensures best possible performance. AMA automatically takes measurements from the specific motor connected and compensates for installation variances.

1. Connect terminal 27 to terminal 12 or use [MAIN MENU] and set Terminal 27 par. 5-12 to *No operation* (par. 5-12 [0])
2. Press [QUICK MENU], select "Q2 Quick Setup", scroll down to AMA par. 1-29.
3. Press [OK] to activate the AMA par. 1-29.

4. Choose between complete or reduced AMA. If sine wave filter is mounted, run only reduced AMA, or remove sine wave filter during AMA procedure.
5. Press [OK] key. Display should show "Press [Hand on] to start".
6. Press [Hand on] key. A progress bar indicates if AMA is in progress.

Stop the AMA during operation

1. Press the [OFF] key - the frequency converter enters into alarm mode and the display shows that the AMA was terminated by the user.

Successful AMA

1. The display shows "Press [OK] to finish AMA".
2. Press the [OK] key to exit the AMA state.

Unsuccessful AMA

1. The frequency converter enters into alarm mode. A description of the alarm can be found in the *Troubleshooting* section.
2. "Report Value" in the [Alarm Log] shows the last measuring sequence carried out by the AMA, before the frequency converter entered alarm mode. This number along with the description of the alarm will assist troubleshooting. If contacting Danfoss Service, make sure to mention number and alarm description.

5



NB!

Unsuccessful AMA is often caused by incorrectly entered motor name plate data or too big difference between the motor power size and the frequency converter power size.

Step 4. Set speed limit and ramp time

Set up the desired limits for speed and ramp time.

Minimum Reference	par. 3-02
Maximum Reference	par. 3-03

Motor Speed Low Limit	par. 4-11 or 4-12
Motor Speed High Limit	par. 4-13 or 4-14

Ramp 1 Ramp Up Time [s]	par. 3-41
Ramp 1 Ramp Down Time 1 [s]	par. 3-42

6 Commissioning and Application Examples

6.1 Quick Setup

6.1.1 Quick Menu Mode

The GLCP provides access to all parameters listed under the Quick Menus. To set parameters using the [Quick Menu] button:

Pressing [Quick Menu] the list indicates the different areas contained in the Quick menu.

Efficient parameter set-up for water applications

The parameters can easily be set up for the vast majority of the water and wastewater applications only by using the [Quick Menu].

The optimum way to set parameters through the [Quick Menu] is by following the below steps:

1. Press [Quick Setup] for selecting basic motor settings, ramp times, etc.
2. Press [Function Setups] for setting up the required functionality of the frequency converter - if not already covered by the settings in [Quick Setup].
3. Choose between *General Settings*, *Open Loop Settings* and *Closed Loop Settings*.

It is recommended to do the set-up in the order listed.

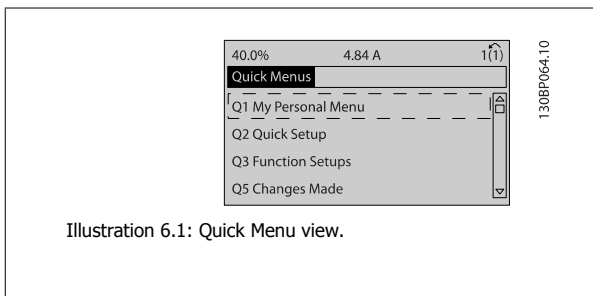

Illustration 6.1: Quick Menu view.

Par.	Designation	[Units]
0-01	Language	
1-20	Motor Power	[kW]
1-22	Motor Voltage	[V]
1-23	Motor Frequency	[Hz]
1-24	Motor Current	[A]
1-25	Motor Nominal Speed	[RPM]
3-41	Ramp 1 Ramp up Time	[s]
3-42	Ramp 1 Ramp down Time	[s]
4-11	Motor Speed Low Limit	[RPM]
4-13	Motor Speed High Limit	[RPM]
1-29	Automatic Motor Adaptation (AMA)	

Table 6.1: Quick Setup parameters. Please see section *Commonly Used Parameters - Explanations*

If *No Operation* is selected in terminal 27 no connection to +24 V on terminal 27 is necessary to enable start.

If *Coast Inverse* (factory default value) is selected in Terminal 27, a connection to +24V is necessary to enable start.

NB!

For detailed parameter descriptions, please see the following section on *Commonly Used Parameters - Explanations*.

6.2.1 Start/Stop

Terminal 18 = start/stop par. 5-10 [8] *Start*

Terminal 27 = No operation par. 5-12 [0] *No operation* (Default *coast inverse*)

Par. 5-10 *Digital Input*, Terminal 18 = *Start* (default)

Par. 5-12 *Digital Input*, Terminal 27 = *coast inverse* (default)

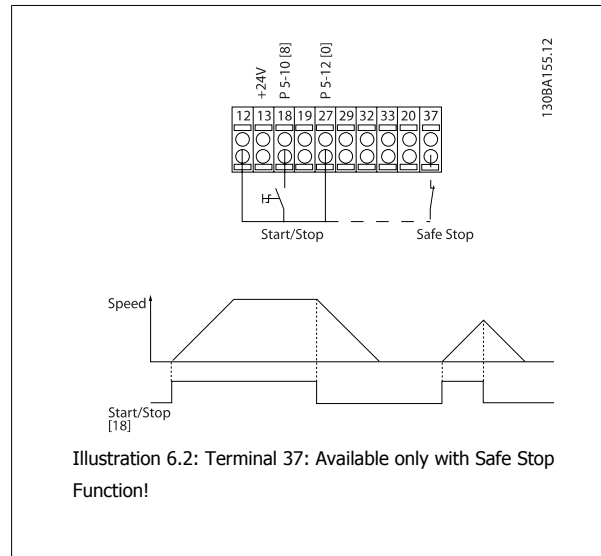

6

6.2.2 Closed Loop Wiring

Terminal 12 /13: +24V DC

Terminal 18: Start par. 5-18 [8] Start (Default)

Terminal 27: Coast par. 5-12 [2] coast inverse (Default)

Terminal 54: Analog input

L1-L3: Mains terminals

U,V and W: Motor terminals

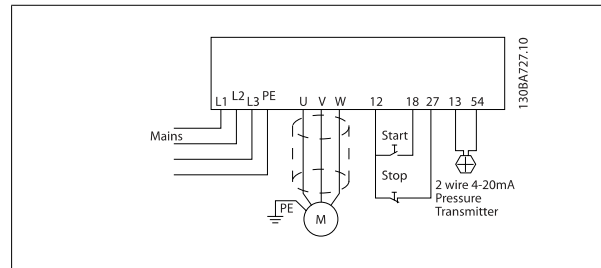

6.2.3 Submersible Pump Application

The system consists of a submersible pump controlled by a Danfoss Automation VT Drive and a pressure transmitter. The transmitter gives a 4-20 mA feedback signal to the Automation VT Drive, which keeps a constant pressure by controlling the speed of the pump. To design a drive for a submersible pump application, there are a few important issues to take into consideration. Therefore the drive used must be chosen according to motor current.

1. The motor is a so called "Can motor" with a stainless steel can between the rotor and stator. There is a larger and a more magnetic resistant air-gap than on a normal motor hence a weaker field which results in the motors being designed with a higher rated current than a norm motor with similar rated power.
2. The pump contains thrust bearings which will be damaged when running below minimum speed which normally will be 30 Hz.
3. The motor reactance is nonlinear in submersible pump motors and therefore Automatic Motor Adaption (AMA) may not be possible. However, normally submersible pumps are operated with very long motor cables that might eliminate the nonlinear motor reactance and enable the drive to perform AMA. If AMA fails, the motor data can be set from parameter group 1-3* (see motor datasheet). Be aware that if AMA has succeeded the drive will compensate for voltage drop in the long motor cables, so if the Advanced motor data are set manually, the length of the motor cable must be taken into considerations to optimize system performance.
4. It is important that the system is operated with a minimum of wear and tear of the pump and motor. A Danfoss Sine-Wave filter can lower the motor insulation stress and increase lifetime (check actual motor insulation and the frequency converter du/dt specification). It is recommended to use a filter to reduce the need for service.
5. EMC performance can be difficult to achieve due to the fact that the special pump cable which is able to withstand the wet conditions in the well normally is unshielded. A solution could be to use a screened cable above the well and fix the screen to the well pipe if it is made of steel (can also be made of plastic). A Sine-Wave filter will also reduce the EMI from unshielded motor cables.

The special "can motor" is used due to the wet installation conditions. The drive needs to be designed for the system according to output current to be able to run the motor at nominal power.

To prevent damage to the thrust bearings of the pump, it is important to ramp the pump from stop to min. speed as quick as possible. Well-known manufacturers of submersible pumps recommend that the pump is ramped to min. speed (30 Hz) in max. 2 -3 seconds. The new Automation VT Drive is designed with initial and final Ramp for these applications. The initial and final ramps are 2 individual ramps, where Initial Ramp, if enabled, will ramp the motor from stop to min. speed and automatically switch to normal ramp, when min. speed is reached. Final ramp will do the opposite from min. speed to stop in a stop situation.

Pipe-Fill mode can be enabled to prevent water hammering. The Danfoss frequency converter is capable of filling vertical pipes using the PID controller to slowly ramp up the pressure with a user specified rate (units/sec). If enabled the drive will, when it reaches min. speed after startup, enter pipe fill mode. The pressure will slowly be ramped up until it reaches a user specified Filled Set Point, where after the drive automatically disables Pipe Fill Mode and continues in normal closed loop operation.

This feature is designed for irrigation applications.

Electrical Wiring

Typical parameter settings (Typical/recommended settings in brackets.)

Parameters:

Motor Rated Power	Par. 1-20 / par. 1-21
Motor Rated Voltage	Par. 1-22
Motor Current	Par. 1-24
Motor Rated Speed	Par. 1-28
Enable Reduced Automatic Motor Adaptation (AMA in par. 1-29)	



NB!

Note the analog input 2, (terminal (54) format must be set to mA. (switch 202).

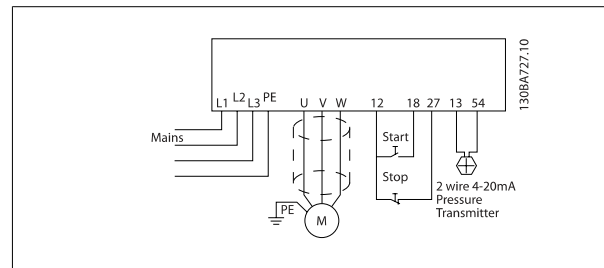

Min. Reference	Par. 3-01	(30 Hz)
Max. Reference	Par. 3-02	(50/60 Hz)
Initial Ramp Up Time	Par. 3-84	(2 sec.)
Final Ramp Down Time	Par. 3-88	(2 sec.)
Normal Ramp Up Time	Par. 3-41	(8 sec. depending on size)
Normal Ramp Down Time	Par. 3-42	(8 sec. depending on size)
Motor Min. Speed	Par. 4-11	(30 Hz)
Motor Max. Speed	Par. 4-13	(50/60 Hz)

Use the "Closed Loop" wizard under "Quick Menu_Funtion_Setup", to easily set up the feedback settings in the PID controller.

Pipe Fill Mode		
Pipe Fill Enable	Par. 29-00	
Pipe Fill Rate	Par. 29-04	(Feedback units/sec.)
Filled Set Point	Par. 29-05	(Feedback units)

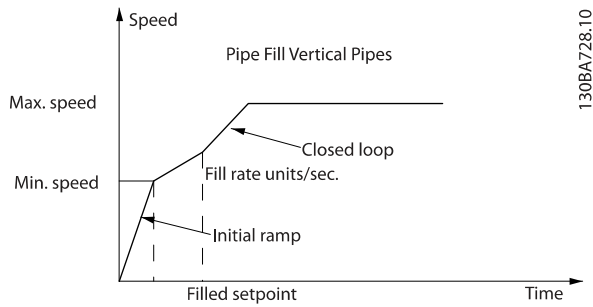

7 How to Operate the Frequency Converter

7.1 Ways of Operation

The frequency converter can be operated in 3 ways:

1. Graphical Local Control Panel (GLCP), see 6.1.2
2. Numeric Local Control Panel (NLCP), see 6.1.3
3. RS-485 serial communication or USB, both for PC connection, see 6.1.4

If the frequency converter is fitted with fieldbus option, please refer to relevant documentation.

7.1.1 How to Operate Graphical LCP (GLCP)

The following instructions are valid for the GLCP (LCP 102).

The GLCP is divided into four functional groups:

1. Graphical display with Status lines.
2. Menu keys and indicator lights (LED's) - selecting mode, changing parameters and switching between display functions.
3. Navigation keys and indicator lights (LEDs).
4. Operation keys and indicator lights (LEDs).

Graphical display:

The LCD-display is back-lit with a total of 6 alpha-numeric lines. All data is displayed on the LCP which can show up to five operating variables while in [Status] mode.

Display lines:

- a. **Status line:** Status messages displaying icons and graphics.
- b. **Line 1-2:** Operator data lines displaying data and variables defined or chosen by the user. By pressing the [Status] key, up to one extra line can be added.
- c. **Status line:** Status messages displaying text.

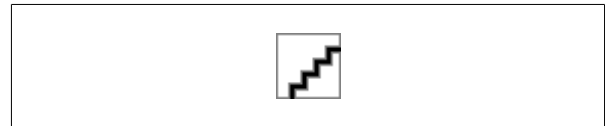

The display is divided into 3 sections:

Top section (a)

shows the status when in status mode or up to 2 variables when not in status mode and in the case of Alarm/Warning.

The number of the Active Set-up (selected as the Active Set-up in par. 0-10) is shown. When programming in another Set-up than the Active Set-up, the number of the Set-up being programmed appears to the right in brackets.

Middle section (b)

shows up to 5 variables with related unit, regardless of status. In case of alarm/warning, the warning is shown instead of the variables.

It is possible to toggle between three status read-out displays by pressing the [Status] key.

Operating variables with different formatting are shown in each status screen - see below.

Several values or measurements can be linked to each of the displayed operating variables. The values / measurements to be displayed can be defined via par. 0-20, 0-21, 0-22, 0-23, and 0-24, which can be accessed via [QUICK MENU], "Q3 Function Setups", "Q3-1 General Settings", "Q3-11 Display Settings".

Each value / measurement readout parameter selected in par. 0-20 to par. 0-24 has its own scale and number of digits after a possible decimal point. Larger numeric values are displayed with few digits after the decimal point.

Ex.: Current readout

5.25 A; 15.2 A 105 A.

Status display I

This read-out state is standard after start-up or initialization.

Use [INFO] to obtain information about the value/measurement linked to the displayed operating variables (1.1, 1.2, 1.3, 2, and 3).

See the operating variables shown in the display in this illustration. 1.1, 1.2 and 1.3 are shown in small size. 2 and 3 are shown in medium size.

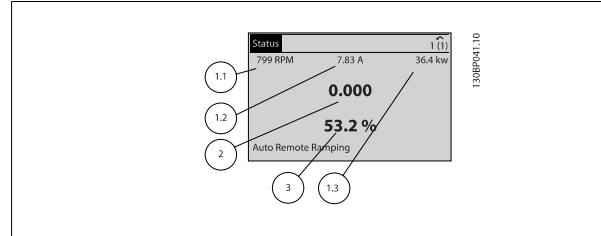

Status display II

See the operating variables (1.1, 1.2, 1.3, and 2) shown in the display in this illustration.
In the example, Speed, Motor current, Motor power and Frequency are selected as variables in the first and second lines.
1.1, 1.2 and 1.3 are shown in small size. 2 is shown in large size.

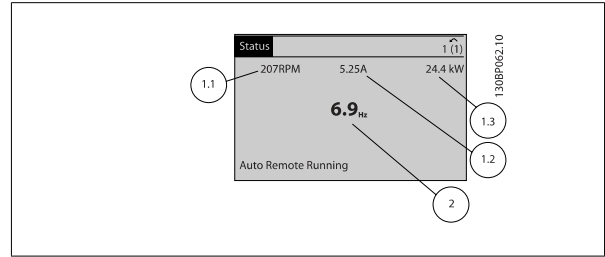

Status display III:

This state displays the event and action of the Smart Logic Control. For further information, see section *Smart Logic Control*.

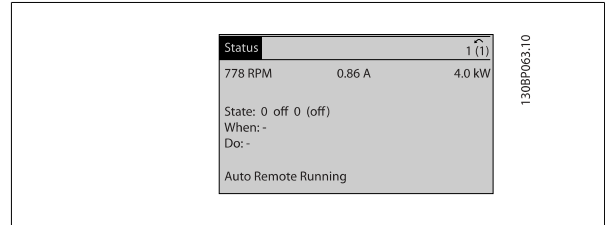

Bottom section

always shows the state of the frequency converter in Status mode.

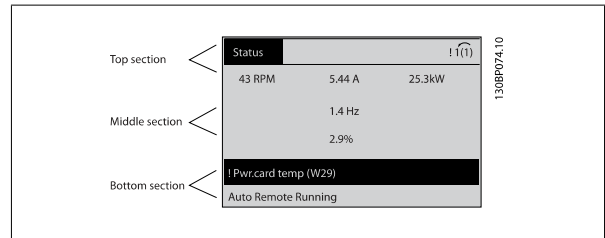

Display contrast adjustment

Press [status] and [▲] for darker display
Press [status] and [▼] for brighter display

Indicator lights (LEDs):

If certain threshold values are exceeded, the alarm and/or warning LED lights up. A status and alarm text appear on the control panel.
The On LED is activated when the frequency converter receives power from mains voltage, a DC bus terminal, or an external 24 V supply. At the same time, the back light is on.

- Green LED/On: Control section is working.
- Yellow LED/Warn.: Indicates a warning.
- Flashing Red LED/Alarm: Indicates an alarm.

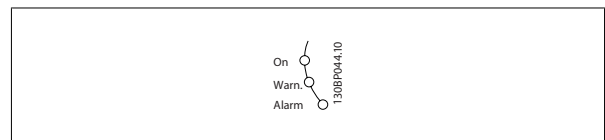

GLCP keys

Menu keys

The menu keys are divided into functions. The keys below the display and indicator lamps are used for parameter set-up, including choice of display indication during normal operation.

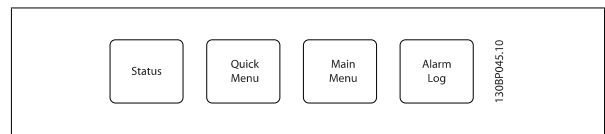

[Status]

Indicates the status of the frequency converter and/or the motor. 3 different readouts can be chosen by pressing the [Status] key: 5 line readouts, 4 line readouts or Smart Logic Control.

Use **[Status]** for selecting the mode of display or for changing back to Display mode from either the Quick Menu mode, the Main Menu mode or Alarm mode. Also use the [Status] key to toggle single or double read-out mode.

[Quick Menu]

Allows quick set-up of the frequency converter. **The most common functions can be programmed here.**

The **[Quick Menu]** consists of:

- **Q1: My Personal Menu**
- **Q2: Quick Setup**
- **Q3: Function Setups**
- **Q5: Changes Made**
- **Q6: Loggings**

The Function set-up provides quick and easy access to all parameters required for the majority of water and wastewater applications including variable torque, constant torque, pumps, dosing pumps, well pumps, booster pumps, mixer pumps, aeration blowers and other pump and fan applications. Amongst other features it also includes parameters for selecting which variables to display on the LCP, digital preset speeds, scaling of analog references, closed loop single zone and multi-zone applications and specific functions related to water and wastewater applications.

7

The Quick Menu parameters can be accessed immediately unless a password has been created via par. 0-60, 0-61, 0-65 or 0-66. It is possible to switch directly between Quick Menu mode and Main Menu mode.

[Main Menu]

is used for programming all parameters.

The Main Menu parameters can be accessed immediately unless a password has been created via par. 0-60, 0-61, 0-65 or 0-66. For the majority of water and wastewater applications it is not necessary to access the Main Menu parameters but instead the Quick Menu, Quick Setup and Function Setups provides the simplest and quickest access to the typical required parameters.

It is possible to switch directly between Main Menu mode and Quick Menu mode.

Parameter shortcut can be carried out by pressing down the **[Main Menu]** key for 3 seconds. The parameter shortcut allows direct access to any parameter.

[Alarm Log]

displays an Alarm list of the five latest alarms (numbered A1-A5). To obtain additional details about an alarm, use the arrow keys to manoeuvre to the alarm number and press [OK]. Information is displayed about the condition of the frequency converter before it enters the alarm mode.

[Back]

reverts to the previous step or layer in the navigation structure.

[Cancel]

last change or command will be cancelled as long as the display has not been changed.

[Info]

displays information about a command, parameter, or function in any display window. [Info] provides detailed information when needed.

Exit Info mode by pressing either [Info], [Back], or [Cancel].

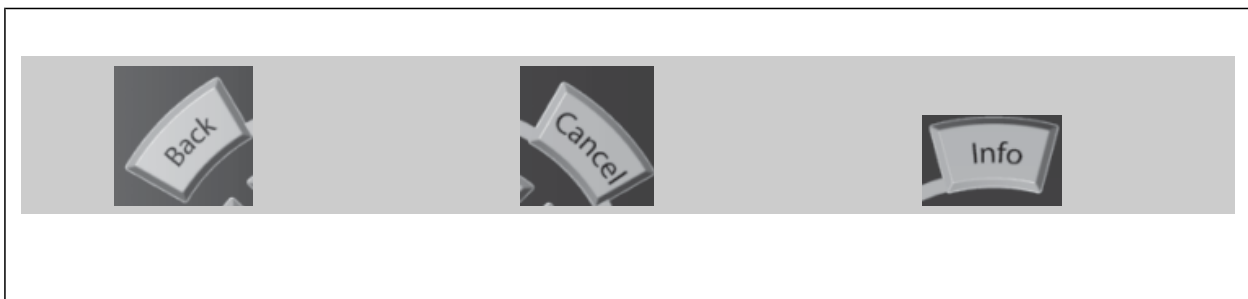

Navigation keys

The four navigation arrows are used to navigate between the different choices available in **[Quick Menu]**, **[Main Menu]** and **[Alarm Log]**. Use the keys to move the cursor.

[OK]

is used for choosing a parameter marked by the cursor and for enabling the change of a parameter.

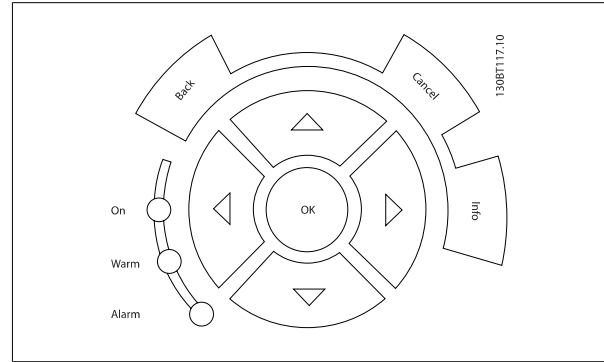

Operation keys

for local control are found at the bottom of the control panel.

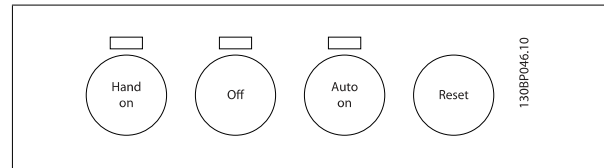

[Hand on]

enables control of the frequency converter via the GLCP. [Hand on] also starts the motor, and it is now possible to give the motor speed reference by means of the arrow keys. The key can be *Enabled* [1] or *Disabled* [0] via par. 0-40 [Hand on] Key on LCP.

The following control signals will still be active when [Hand on] is activated:

- [Hand on] - [Off] - [Auto on]
- Reset
- Coasting stop inverse (motor coasting to stop)
- Reversing
- Set-up select lsb - Set-up select msb
- Stop command from serial communication
- Quick stop
- DC brake

NB!
External stop signals activated by means of control signals or a serial bus will override a "start" command via the LCP.

[Off]

stops the connected motor. The key can be *Enabled* [1] or *Disabled* [0] via par. 0-41 [Off] key on LCP. If no external stop function is selected and the [Off] key is inactive the motor can only be stopped by disconnecting the mains supply.

[Auto on]

enables the frequency converter to be controlled via the control terminals and/or serial communication. When a start signal is applied on the control terminals and/or the bus, the frequency converter will start. The key can be *Enabled* [1] or *Disabled* [0] via par. 0-42 [Auto on] key on LCP.

NB!
An active HAND-OFF-AUTO signal via the digital inputs has higher priority than the control keys [Hand on] – [Auto on].

[Reset]

is used for resetting the frequency converter after an alarm (trip). The key can be *Enabled* [1] or *Disabled* [0] via par. 0-43 *Reset Keys on LCP*.

The parameter shortcut

can be carried out by holding down the [Main Menu] key for 3 seconds. The parameter shortcut allows direct access to any parameter.

7.1.2 How to Operate Numeric (NLCP)

The following instructions are valid for the NLCP (LCP 101).

The control panel is divided into four functional groups:

1. Numeric display.
2. Menu key and indicator lights (LEDs) - changing parameters and switching between display functions.
3. Navigation keys and indicator lights (LEDs).
4. Operation keys and indicator lights (LEDs).

Select one of the following modes:

Status Mode: Displays the status of the frequency converter or the motor.

If an alarm occurs, the NLCP automatically switches to status mode. A number of alarms can be displayed.

Quick Setup or Main Menu Mode: Display parameters and parameter settings.



NB!

Parameter copy is not possible with Numeric Local Control Panel (LCP101).

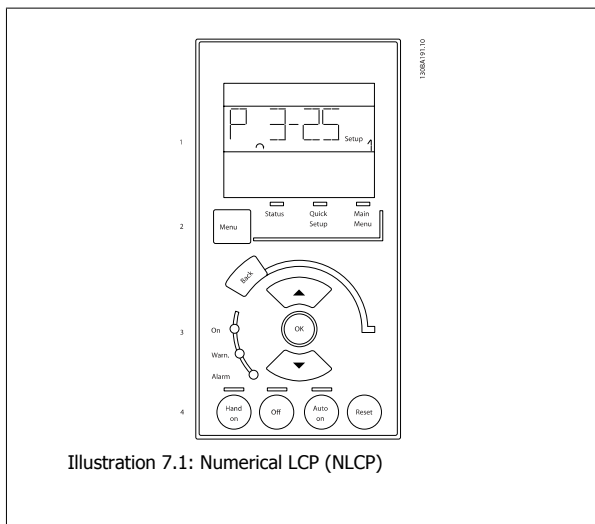

Illustration 7.1: Numerical LCP (NLCP)

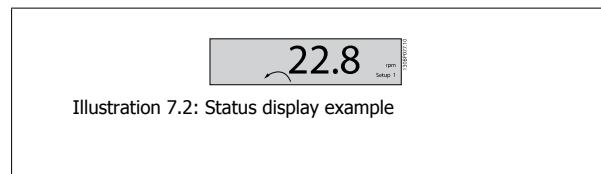

Illustration 7.2: Status display example

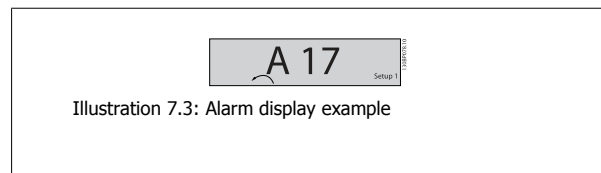

Illustration 7.3: Alarm display example

Indicator lights (LEDs):

- Green LED/On: Indicates if control section is on.
- Yellow LED/Wrn.: Indicates a warning.
- Flashing red LED/Alarm: Indicates an alarm.

Menu key

Select one of the following modes:

- Status
- Quick Setup
- Main Menu

Main Menu

is used for programming all parameters.

The parameters can be accessed immediately unless a password has been created via par. 0-60 *Main Menu Password*, par. 0-61 *Access to Main Menu w/o Password*, par. 0-65 *Personal Menu Password* or par. 0-66 *Access to Personal Menu w/o Password*.

Quick Setup is used to set up the frequency converter using only the most essential parameters.

The parameter values can be changed using the up/down arrows when the value is flashing.

Select Main Menu by pressing the [Menu] key a number of times until the Main Menu LED is lit.

Select the parameter group [xx-__] and press [OK]

Select the parameter [__-xx] and press [OK]

If the parameter is an array parameter select the array number and press [OK]

Select the wanted data value and press [OK]

Navigation keys

[Back]

for stepping backwards

Arrow [▲] [▼]

keys are used for manoeuvring between parameter groups, parameters and within parameters

[OK]

is used for choosing a parameter marked by the cursor and for enabling the change of a parameter.

Operation keys

Keys for local control are found at the bottom of the control panel.

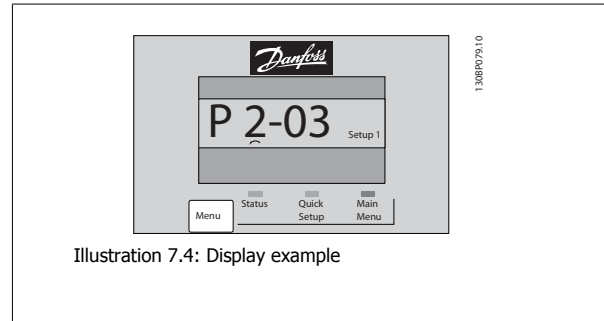

Illustration 7.4: Display example

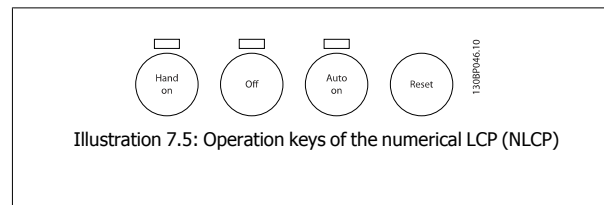

Illustration 7.5: Operation keys of the numerical LCP (NLCP)

[Hand on]

enables control of the frequency converter via the . [Hand on] also starts the motor and it is now possible to enter the motor speed data by means of the arrow keys. The key can be *Enabled* [1] or *Disabled* [0] via par. 0-40 *[Hand on] Key on LCP*.

External stop signals activated by means of control signals or a serial bus will override a 'start' command via the .

The following control signals will still be active when [Hand on] is activated:

- [Hand on] - [Off] - [Auto on]
- Reset
- Coasting stop inverse
- Reversing
- Set-up select lsb - Set-up select msb
- Stop command from serial communication
- Quick stop
- DC brake

[Off]

stops the connected motor. The key can be *Enabled* [1] or *Disabled* [0] via par. 0-41 *[Off] Key on LCP*.

If no external stop function is selected and the [Off] key is inactive the motor can be stopped by disconnecting the mains supply.

[Auto on]

enables the frequency converter to be controlled via the control terminals and/or serial communication. When a start signal is applied on the control terminals and/or the bus, the frequency converter will start. The key can be *Enabled* [1] or *Disabled* [0] via par. 0-42 *[Auto on] Key on LCP*.

**NB!**

An active HAND-OFF-AUTO signal via the digital inputs has higher priority than the control keys [Hand on] [Auto on].

[Reset]

is used for resetting the frequency converter after an alarm (trip). The key can be *Enabled* [1] or *Disabled* [0] via par. 0-43 [Reset] Key on LCP.

7.1.3 Changing Data

1. Press [Quick Menu] or [Main Menu] key.
2. Use [▲] and [▼] keys to find parameter group to edit.
3. Press [OK] key.
4. Use [▲] and [▼] keys to find parameter to edit.
5. Press [OK] key.
6. Use [▲] and [▼] keys to select correct parameter setting. Or, to move to digits within a number, use keys. Cursor indicates digit selected to change. [▲] key increases the value, [▼] key decreases the value.
7. Press [Cancel] key to disregard change, or press [OK] key to accept change and enter new setting.

7

7.1.4 Changing a Text Value

If the selected parameter is a text value, change the text value by means of the up/down navigation keys.

The up key increases the value, and the down key decreases the value. Place the cursor on the value to be saved and press [OK].

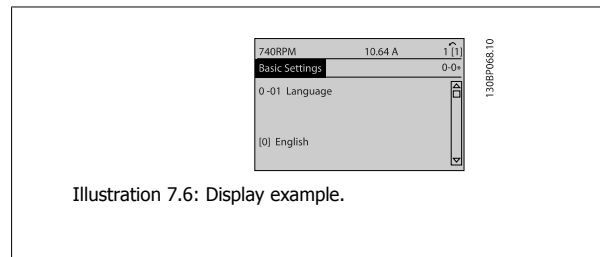

Illustration 7.6: Display example.

7.1.5 Changing a Group of Numeric Data Values

If the chosen parameter represents a numeric data value, change the chosen data value by means of the [←] and [→] navigation keys as well as the up/down [▲] [▼] navigation keys. Use the [←] and [→] navigation keys to move the cursor horizontally.

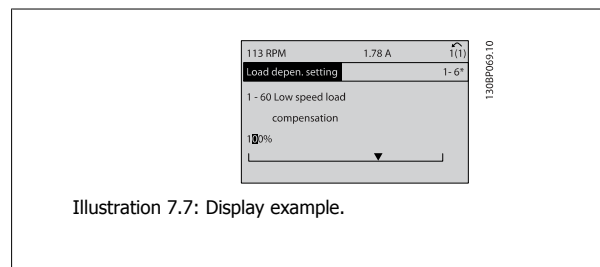
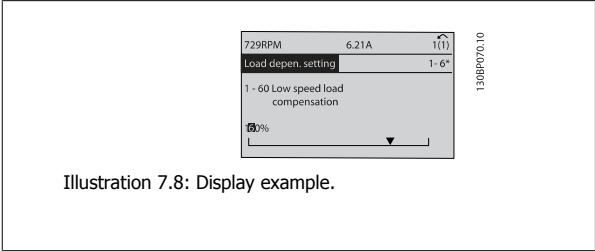

Illustration 7.7: Display example.

Use the up/down navigation keys to change the data value. The up key enlarges the data value, and the down key reduces the data value. Place the cursor on the value to be saved and press [OK].



7.1.6 Changing of Data Value, Step-by-Step

Certain parameters can be changed step by step or infinitely variably. This applies to par. 1-20 *Motor Power [kW]*, par. 1-22 *Motor Voltage* and par. 1-23 *Motor Frequency*.

The parameters are changed both as a group of numeric data values and as numeric data values infinitely variably.

7.1.7 Read-out and Programming of Indexed Parameters

Parameters are indexed when placed in a rolling stack.

Par. 15-30 *Alarm Log: Error Code* to par. 15-32 *Alarm Log: Time* contain a fault log which can be read out. Choose a parameter, press [OK], and use the up/down navigation keys to scroll through the value log.

Use par. 3-10 *Preset Reference* as another example:

Choose the parameter, press [OK], and use the up/down navigation keys to scroll through the indexed values. To change the parameter value, select the indexed value and press [OK]. Change the value by using the up/down keys. Press [OK] to accept the new setting. Press [Cancel] to abort. Press [Back] to leave the parameter.

7.1.8 Tips and Tricks

- * For the majority of water and wastewater applications the Quick Menu, Quick Setup and Function Setups provides the simplest and quickest access to all the typical parameters required.
- * Whenever possible, performing an AMA, will ensure best shaft performance
- * Contrast of the display can be adjusted by pressing [Status] and [▲] for darker display or by pressing [Status] and [▼] for brighter display
- * Under [Quick Menu] and [Changes Made] all parameters that have been changed from factory settings are displayed
- * Press and hold [Main Menu] key for 3 seconds for access to any parameter
- * For service purposes it is recommended to copy all parameters to the LCP, see par 0-50 for further information

Table 7.1: Tips and tricks

7.1.9 Quick Transfer of Parameter Settings when using GLCP

Once the set-up of a frequency converter is complete, it is recommended to store (backup) the parameter settings in the GLCP or on a PC via MCT 10 Set-up Software Tool.



NB!

Stop the motor before performing any of these operations.

Data storage in :

1. Go to par. 0-50 *LCP Copy*
2. Press the [OK] key
3. Select "All to "
4. Press the [OK] key

All parameter settings are now stored in the GLCP indicated by the progress bar. When 100% is reached, press [OK].

The GLCP can now be connected to another frequency converter and the parameter settings copied to this frequency converter.

Data transfer from to Frequency converter:

1. Go to par. 0-50 *LCP Copy*
2. Press the [OK] key
3. Select "All from "
4. Press the [OK] key

The parameter settings stored in the GLCP are now transferred to the frequency converter indicated by the progress bar. When 100% is reached, press [OK].

7.1.10 Initialisation to Default Settings

There are two ways to initialise the frequency converter to default: Recommended initialisation and manual initialisation. Please be aware that they have different impact according to the below description.

Recommended initialisation (via par. 14-22 *Operation Mode*)

1. Select par. 14-22 *Operation Mode*
2. Press [OK]
3. Select "Initialisation" (for NLCP select "2")
4. Press [OK]
5. Remove power to unit and wait for display to turn off.
6. Reconnect power and the frequency converter is reset. Note that first start-up takes a few more seconds
7. Press [Reset]

par. 14-22 *Operation Mode* initialises all except:

- par. 14-50 *RFI Filter*
- par. 8-30 *Protocol*
- par. 8-31 *Address*
- par. 8-32 *Baud Rate*
- par. 8-35 *Minimum Response Delay*
- par. 8-36 *Max Response Delay*
- par. 8-37 *Maximum Inter-Char Delay*
- par. 15-00 *Operating Hours* to par. 15-05 *Over Volt's*
- par. 15-20 *Historic Log: Event* to par. 15-22 *Historic Log: Time*
- par. 15-30 *Alarm Log: Error Code* to par. 15-32 *Alarm Log: Time*

NB!
Parameters selected in par. 0-25 *My Personal Menu*, will stay present, with default factory setting.

Manual initialisation

NB!
When carrying out manual initialisation, serial communication, RFI filter settings and fault log settings are reset.
Removes parameters selected in par. 0-25 *My Personal Menu*

1. Disconnect from mains and wait until the display turns off.
- 2a. Press [Status] - [Main Menu] - [OK] at the same time while power up for Graphical LCP (GLCP)
- 2b. Press [Menu] while power up for LCP 101, Numerical Display
3. Release the keys after 5 s
4. The frequency converter is now programmed according to default settings

This parameter initialises all except:

- par. 15-00 *Operating Hours*
- par. 15-03 *Power Up's*
- par. 15-04 *Over Temp's*
- par. 15-05 *Over Volt's*

7.1.11 RS-485 Bus Connection

One or more frequency converters can be connected to a controller (or master) using the RS-485 standard interface. Terminal 68 is connected to the P signal (TX+, RX+), while terminal 69 is connected to the N signal (TX-, RX-).

If more than one frequency converter is connected to a master, use parallel connections.

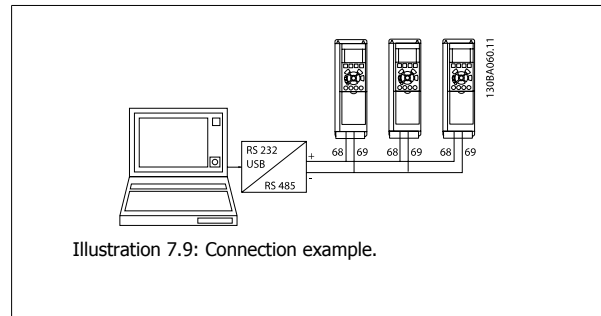

Illustration 7.9: Connection example.

In order to avoid potential equalizing currents in the screen, earth the cable screen via terminal 61, which is connected to the frame via an RC-link.

Bus termination

The RS-485 bus must be terminated by a resistor network at both ends. If the drive is the first or the last device in the RS-485 loop, set the switch S801 on the control card for ON.

For more information, see the paragraph *Switches S201, S202, and S801*.

7

7.1.12 How to Connect a PC to the Frequency Converter

To control or program the frequency converter from a PC, install the PC-based Configuration Tool MCT 10.

The PC is connected via a standard (host/device) USB cable, or via the RS-485 interface as shown in the *Design Guide, chapter How to Install > Installation of misc. connections*.



NB!

The USB connection is galvanically isolated from the supply voltage (PELV) and other high-voltage terminals. The USB connection is connected to protection earth on the frequency converter. Use only isolated laptop as PC connection to the USB connector on the frequency converter.

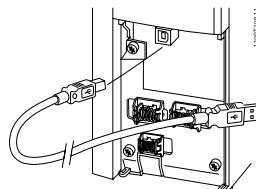

Illustration 7.10: For control cable connections, see section on *Control Terminals*.

7.1.13 PC Software Tools

PC-based Configuration Tool MCT 10

All Frequency converters are equipped with a serial communication port. provides a PC tool for communication between PC and frequency converter, PC-based Configuration Tool MCT 10. Please check the section on *Available Literature* for detailed information on this tool.

MCT 10 set-up software

MCT 10 has been designed as an easy to use interactive tool for setting parameters in our frequency converters. The software can be downloaded from the internet site <http://www..com/BusinessAreas/DrivesSolutions/Softwaredownload/DDPC+Software+Program.htm>.

The MCT 10 set-up software will be useful for:

- Planning a communication network off-line. MCT 10 contains a complete frequency converter database
- Commissioning frequency converters on line
- Saving settings for all frequency converters
- Replacing a frequency converter in a network
- Simple and accurate documentation of frequency converter settings after commissioning.
- Expanding an existing network
- Future developed frequency converters will be supported

MCT 10 set-up software supports Profibus DP-V1 via a Master class 2 connection. It makes it possible to on line read/write parameters in a frequency converter via the Profibus network. This will eliminate the need for an extra communication network.

Save frequency converter settings:

1. Connect a PC to the unit via USB com port. (Note: Use a PC, which is isolated from the mains, in conjunction with the USB port. Failure to do so may damage equipment.)
2. Open MCT 10 Set-up Software
3. Choose "Read from drive"
4. Choose "Save as"

All parameters are now stored in the PC.

Load frequency converter settings:

1. Connect a PC to the frequency converter via USB com port
2. Open MCT 10 Set-up software
3. Choose "Open"– stored files will be shown
4. Open the appropriate file
5. Choose "Write to drive"

All parameter settings are now transferred to the frequency converter.

A separate manual for MCT 10 Set-up Software is available: *MG.10.Rx.yy*.

7

The MCT 10 Set-up software modules

The following modules are included in the software package:

	MCT Set-up 10 Software Setting parameters Copy to and from frequency converters Documentation and print out of parameter settings incl. diagrams
	Ext. user interface Preventive Maintenance Schedule Clock settings Timed Action Programming Smart Logic Controller Set-up

Ordering number:

Please order the CD containing MCT 10 Set-up Software using code number 130B1000.

MCT 10 can also be downloaded from the Internet: *WWW.DANFOSS.COM*, Business Area: Motion Controls.

8 How to Programme the Frequency Converter

8.1 How to Programme

8.1.1 Parameter Set-up

Overview of parameter groups

Group	Title	Function
0-	Operation / Display	Parameters related to the fundamental functions of the frequency converter, function of the LCP buttons and configuration of the LCP display.
1-	Load / Motor	Parameter group for motor settings.
2-	Brakes	Parameter group for setting brake features in the frequency converter.
3-	Reference / Ramps	Parameters for reference handling, definitions of limitations, and configuration of the reaction of the frequency converter to changes.
4-	Limits / Warnings	Parameter group for configuring limits and warnings.
5-	Digital In/Out	Parameter group for configuring the digital inputs and outputs.
6-	Analog In/Out	Parameter group for configuration of the analog inputs and outputs.
8-	Communication and Options	Parameter group for configuring communications and options.
9-	Profibus	Parameter group for Profibus-specific parameters.
10-	DeviceNet Fieldbus	Parameter group for DeviceNet-specific parameters.
13-	Smart Logic	Parameter group for Smart Logic Control
14-	Special Functions	Parameter group for configuring special frequency converter functions.
15-	Drive Information	Parameter group containing frequency converter information such as operating data, hardware configuration and software versions.
16-	Data Readouts	Parameter group for data read-outs, e.g. actual references, voltages, control, alarm, warning and status words.
18-	Info and Readouts	This parameter group contains the last 10 Preventive Maintenance logs.
20-	Drive Closed Loop	This parameter group is used for configuring the closed loop PID Controller that controls the output frequency of the unit.
21-	Extended Closed Loop	Parameters for configuring the three Extended Closed Loop PID Controllers.
22-	Application Functions	These parameters monitor water applications.
23-	Time-based Functions	These parameters are for actions needed to be performed on a daily or weekly basis, e.g. different references for working hours/non-working hours.
25-	Basic Cascade Controller Functions	Parameters for configuring the Basic Cascade Controller for sequence control of multiple pumps.
26-	Analog I/O Option MCB 109	Parameters for configuring the Analog I/O Option MCB 109.
27-	Extended Cascade Control	Parameters for configuring the Extended Cascade Control.
29-	Water Application Functions	Parameters for setting water specific functions.
31-	Bypass Option	Parameters for configuring the Bypass Option

Table 8.1: Parameter groups

Parameter descriptions and selections are displayed on the graphic (GLCP) or numeric (NLCP) in the display area. (See Section 5 for details.) Access the parameters by pressing the [Quick Menu] or [Main Menu] key on the control panel. The quick menu is used primarily for commissioning the unit at start-up by providing those parameters necessary to start operation. The main menu provides access to all parameters for detailed application programming.

All digital input/output and analog input/output terminals are multifunctional. All terminals have factory default functions suitable for the majority of water applications but if other special functions are required, they must be programmed in parameter group 5 or 6.

8.1.2 Q1 My Personal Menu

Parameters defined by the user can be stored in Q1 My Personal Menu.

Select *My Personal Menu* to display only the parameters, which have been pre-selected and programmed as personal parameters. For example, a pump or equipment OEM may have pre-programmed these to be in My Personal Menu during factory commissioning to make on site commissioning / fine tuning simpler.. These parameters are selected in par. 0-25 *My Personal Menu*. Up to 20 different parameters can be defined in this menu.

Q1 My Personal Menu	
20-21	Setpoint 1
20-93	PID Proportional Gain
20-94	PID Integral Time

8.1.3 Q2 Quick Setup

The parameters in Q2 Quick Setup are the basic parameters which are always needed to set-up the frequency converter to operation.

Q2 Quick Setup	
Parameter number and name	Unit
0-01	Language
1-20	Motor Power kW
1-22	Motor Voltage V
1-23	Motor Frequency Hz
1-24	Motor Current A
1-25	Motor Nominal Speed RPM
3-41	Ramp 1 Ramp Up Time s
3-42	Ramp 1 Ramp Down Time s
4-11	Motor Speed Low Limit RPM
4-13	Motor Speed High Limit RPM
1-29	Automatic Motor Adaptation (AMA)

8.1.4 Q3 Function Setups

The Function Setup provides quick and easy access to all parameters required for the majority of water and wastewater applications including variable torque, constant torque, pumps, dosing pumps, well pumps, booster pumps, mixer pumps, aeration blowers and other pump and fan applications. Amongst other features it also includes parameters for selecting which variables to display on the LCP, digital preset speeds, scaling of analog references, closed loop single zone and multi-zone applications and specific functions related to water and wastewater applications.

How to access Function Set-up - example:

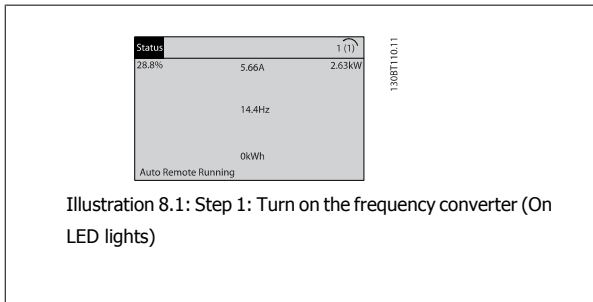

Illustration 8.1: Step 1: Turn on the frequency converter (On LED lights)

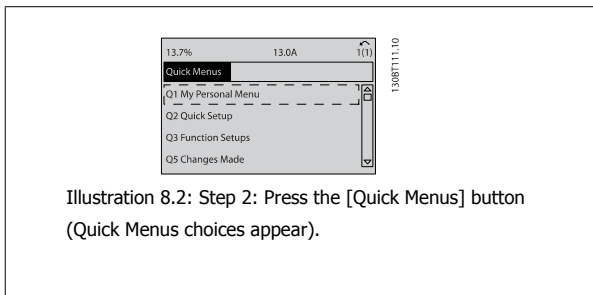

Illustration 8.2: Step 2: Press the [Quick Menus] button (Quick Menu choices appear).

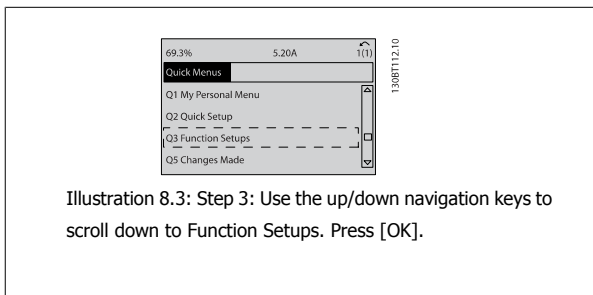

Illustration 8.3: Step 3: Use the up/down navigation keys to scroll down to Function Setups. Press [OK].

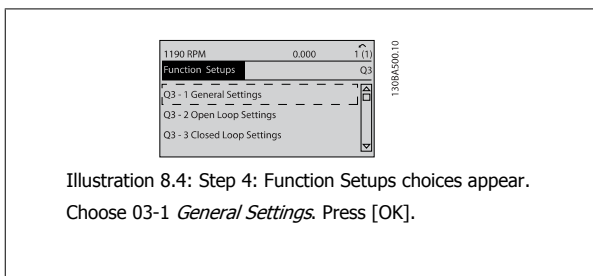

Illustration 8.4: Step 4: Function Setups choices appear. Choose Q3-1 *General Settings*. Press [OK].

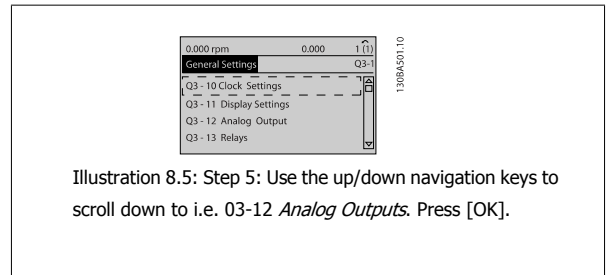

Illustration 8.5: Step 5: Use the up/down navigation keys to scroll down to i.e. Q3-12 *Analog Outputs*. Press [OK].

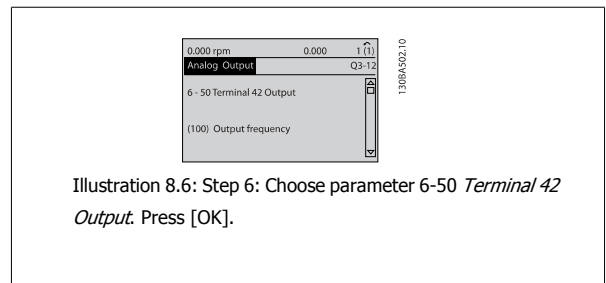

Illustration 8.6: Step 6: Choose parameter 6-50 *Terminal 42 Output*. Press [OK].

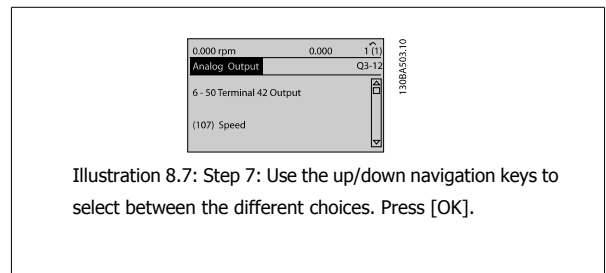

Illustration 8.7: Step 7: Use the up/down navigation keys to select between the different choices. Press [OK].

The Function Setup parameters are grouped in the following way:

Q3-1 General Settings			
Q3-10 Clock Settings	Q3-11 Display Settings	Q3-12 Analog Output	Q3-13 Relays
0-70 Set Date and Time	0-20 Display Line 1.1 Small	6-50 Terminal 42 Output	Relay 1 ⇒ 5-40 Function Relay
0-71 Date Format	0-21 Display Line 1.2 Small	6-51 Terminal 42 Output Min Scale	Relay 2 ⇒ 5-40 Function Relay
0-72 Time Format	0-22 Display Line 1.3 Small	6-52 Terminal 42 Output Max Scale	Option relay 7 ⇒ 5-40 Function Relay
0-74 DST/Summertime	0-23 Display Line 2 Large		Option relay 8 ⇒ 5-40 Function Relay
0-76 DST/Summertime Start	0-24 Display Line 3 Large		Option relay 9 ⇒ 5-40 Function Relay
0-77 DST/Summertime End	0-37 Display Text 1		
	0-38 Display Text 2		
	0-39 Display Text 3		

Q3-2 Open Loop Settings	
Q3-20 Digital Reference	Q3-21 Analog Reference
3-02 Minimum Reference	3-02 Minimum Reference
3-03 Maximum Reference	3-03 Maximum Reference
3-10 Preset Reference	6-10 Terminal 53 Low Voltage
5-13 Terminal 29 Digital Input	6-11 Terminal 53 High Voltage
5-14 Terminal 32 Digital Input	6-14 Terminal 53 Low Ref/Feedb. Value
5-15 Terminal 33 Digital Input	6-15 Terminal 53 High Ref/Feedb. Value

Q3-3 Closed Loop Settings	
Q3-30 Feedback Settings	Q3-31 PID Settings
1-00 Configuration Mode	20-81 PID Normal/Inverse Control
20-12 Reference/Feedb.Unit	20-82 PID Start Speed [RPM]
3-02 Minimum Reference	20-21 Setpoint 1
3-03 Maximum Reference	20-93 PID Proportional Gain
6-20 Terminal 54 Low Voltage	20-94 PID Integral Time
6-21 Terminal 54 High Voltage	
6-24 Terminal 54 Low Ref/Feedb Value	
6-25 Terminal 54 High Ref/Feedb Value	
6-00 Live Zero Timeout Time	
6-01 Live Zero Timeout Function	

8

8.1.5 Q5 Changes Made

Q5 Changes Made can be used for fault finding.

Select *Changes made to get information about:*

- the last 10 changes. Use the up/down navigation keys to scroll between the last 10 changed parameters.
- the changes made since default setting.

Select *Loggings* to get information about the display line read-outs. The information is shown as graphs.

Only display parameters selected in par. 0-20 and par. 0-24 can be viewed. It is possible to store up to 120 samples in the memory for later reference.

Please notice that the parameters listed in the below tables for Q5 only serve as examples as they will vary depending on the programming of the particular frequency converter.

Q5-1 Last 10 Changes
20-94 PID Integral Time
20-93 PID Proportional Gain

Q5-2 Since Factory Setting
20-93 PID Proportional Gain
20-94 PID Integral Time

Q5-3 Input Assignments	
Analog Input 53	
Analog Input 54	

8.1.6 Q6 Loggings

Q6 Loggings can be used for fault finding.

Please notice that the parameters listed in the below table for Q6 only serve as examples as they will vary depending on the programming of the particular frequency converter.

Q6 Loggings	
Reference	
Analog Input 53	
Motor Current	
Frequency	
Feedback	
Energy Log	
Trending Cont Bin	
Trending Timed Bin	
Trending Comparison	

8.1.7 Main Menu Mode

Both the GLCP and NLCP provide access to the main menu mode. Select the Main Menu mode by pressing the [Main Menu] key. Illustration 6.2 shows the resulting read-out, which appears on the display of the GLCP. Lines 2 through 5 on the display show a list of parameter groups which can be chosen by toggling the up and down buttons.

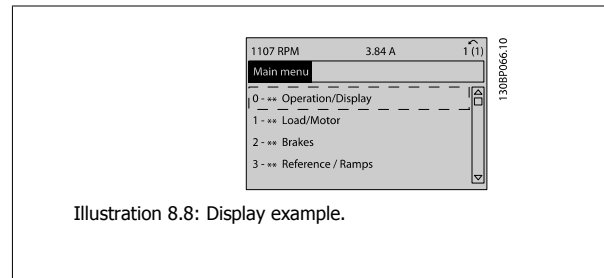

Each parameter has a name and number which remain the same regardless of the programming mode. In the Main Menu mode, the parameters are divided into groups. The first digit of the parameter number (from the left) indicates the parameter group number.

All parameters can be changed in the Main Menu. The configuration of the unit (par. 1-00 *Configuration Mode*) will determine other parameters available for programming. For example, selecting Closed Loop enables additional parameters related to closed loop operation. Option cards added to the unit enable additional parameters associated with the option device.

8.1.8 Parameter Selection

In the Main Menu mode, the parameters are divided into groups. Select a parameter group by means of the navigation keys.

The following parameter groups are accessible:

Group no.	Parameter group:
0	Operation/Display
1	Load/Motor
2	Brakes
3	References/Ramps
4	Limits/Warnings
5	Digital In/Out
6	Analog In/Out
8	Comm. and Options
9	Profibus
10	CAN Fieldbus
11	LonWorks
13	Smart Logic
14	Special Functions
15	Drive Information
16	Data Readouts
18	Data Readouts 2
20	Drive Closed Loop
21	Ext. Closed Loop
22	Application Functions
23	Time-based Functions
24	Fire Mode
25	Cascade Controller
26	Analog I/O Option MCB 109

Table 8.2: Parameter groups.

8

After selecting a parameter group, choose a parameter by means of the navigation keys.

The middle section on the GLCP display shows the parameter number and name as well as the selected parameter value.

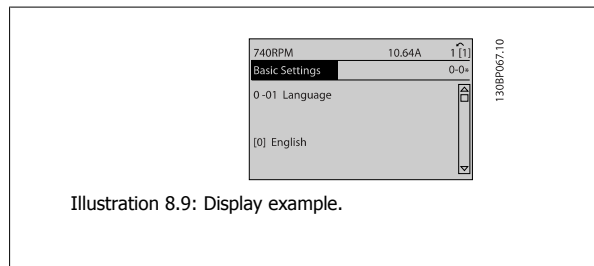

Illustration 8.9: Display example.

8.2 Commonly Used Parameters - Explanations

8.2.1 Main Menu

The Main Menu includes all available parameters in the Automation VT Drive FC322 frequency converter.

All parameters are grouped in a logic way with a group name indicating the function of the parameter group.

All parameters are listed by name and number in the section *Parameter Options* in this Instruction Manual.

All parameters included in the Quick Menu (Q1, Q2, Q3, Q5 and Q6) can be found in the following.

Some of the most used parameters for Automation VT Drive applications are also explained in the following section.

For a detailed explanation of all parameters, please refer to the Automation VT Drive FC322 Programming Guide MG.20.W1.22.

8.2.2 0-** Operation / Display

Parameters related to the fundamental functions of the frequency converter, function of the buttons and configuration of the display.

0-01 Language

Option:

Function:

Defines the language to be used in the display.

The frequency converter can be delivered with 4 different language packages. English and German are included in all packages. English cannot be erased or manipulated.

[0] *	English	Part of Language packages 1 - 4
[1]	German	Part of Language packages 1 - 4
[2]	French	Part of Language package 1
[3]	Danish	Part of Language package 1
[4]	Spanish	Part of Language package 1
[5]	Italian	Part of Language package 1
[6]	Swedish	Part of Language package 1
[7]	Dutch	Part of Language package 1
[10]	Chinese	Language package 2
[20]	Finnish	Part of Language package 1
[22]	English US	Part of Language package 4
[27]	Greek	Part of Language package 4
[28]	Portuguese	Part of Language package 4
[36]	Slovenian	Part of Language package 3
[39]	Korean	Part of Language package 2
[40]	Japanese	Part of Language package 2
[41]	Turkish	Part of Language package 4
[42]	Traditional Chinese	Part of Language package 2
[43]	Bulgarian	Part of Language package 3
[44]	Serbian	Part of Language package 3
[45]	Romanian	Part of Language package 3
[46]	Hungarian	Part of Language package 3
[47]	Czech	Part of Language package 3
[48]	Polish	Part of Language package 4
[49]	Russian	Part of Language package 3
[50]	Thai	Part of Language package 2
[51]	Bahasa Indonesian	Part of Language package 2

0-20 Display Line 1.1 Small

Option:

Function:

Select a variable for display in line 1, left position.

[0]	None	No display value selected
[37]	Display Text 1	Present control word
[38]	Display Text 2	Enables an individual text string to be written, for display in the LCP or to be read via serial communication.
[39]	Display Text 3	Enables an individual text string to be written, for display in the LCP or to be read via serial communication.

[89]	Date and Time Readout	Displays the current date and time.
[953]	Profibus Warning Word	Displays Profibus communication warnings.
[1005]	Readout Transmit Error Counter	View the number of CAN control transmission errors since the last power-up.
[1006]	Readout Receive Error Counter	View the number of CAN control receipt errors since the last power-up.
[1007]	Readout Bus Off Counter	View the number of Bus Off events since the last power-up.
[1013]	Warning Parameter	View a DeviceNet-specific warning word. One separate bit is assigned to every warning.
[1115]	LON Warning Word	Shows the LON-specific warnings.
[1117]	XIF Revision	Shows the version of the external interface file of the Neuron C chip on the LON option.
[1118]	LON Works Revision	Shows the software version of the application program of the Neuron C chip on the LON option.
[1500]	Operating Hours	View the number of running hours of the frequency converter.
[1501]	Running Hours	View the number of running hours of the motor.
[1502]	kWh Counter	View the mains power consumption in kWh.
[1600]	Control Word	View the Control Word sent from the frequency converter via the serial communication port in hex code.
[1601] *	Reference [Unit]	Total reference (sum of digital/analog/preset/bus/freeze ref./catch up and slow-down) in selected unit.
[1602]	Reference %	Total reference (sum of digital/analog/preset/bus/freeze ref./catch up and slow-down) in percent.
[1603]	Status Word	Present status word
[1605]	Main Actual Value [%]	One or more warnings in a Hex code
[1609]	Custom Readout	View the user-defined readouts as defined in par. 0-30, 0-31 and 0-32.
[1610]	Power [kW]	Actual power consumed by the motor in kW.
[1611]	Power [hp]	Actual power consumed by the motor in HP.
[1612]	Motor Voltage	Voltage supplied to the motor.
[1613]	Motor Frequency	Motor frequency, i.e. the output frequency from the frequency converter in Hz.
[1614]	Motor Current	Phase current of the motor measured as effective value.
[1615]	Frequency [%]	Motor frequency, i.e. the output frequency from the frequency converter in percent.
[1616]	Torque [Nm]	Present motor load as a percentage of the rated motor torque.
[1617]	Speed [RPM]	Speed in RPM (revolutions per minute) i.e. the motor shaft speed in closed loop based on the entered motor nameplate data, the output frequency and the load on the frequency converter.
[1618]	Motor Thermal	Thermal load on the motor, calculated by the ETR function. See also parameter group 1-9* Motor Temperature.
[1622]	Torque [%]	Shows the actual torque produced, in percentage.
[1630]	DC Link Voltage	Intermediate circuit voltage in the frequency converter.
[1632]	BrakeEnergy/s	Present brake power transferred to an external brake resistor. Stated as an instantaneous value.
[1633]	BrakeEnergy/2 min	Brake power transferred to an external brake resistor. The mean power is calculated continuously for the most recent 120 seconds.
[1634]	Heatsink Temp.	Present heat sink temperature of the frequency converter. The cut-out limit is 95 ±5 °C; cutting back in occurs at 70 ±5° C.
[1635]	Thermal Drive Load	Percentage load of the inverters
[1636]	Inv. Nom. Current	Nominal current of the frequency converter
[1637]	Inv. Max. Current	Maximum current of the frequency converter
[1638]	SL Control State	State of the event executed by the control
[1639]	Control Card Temp.	Temperature of the control card.
[1650]	External Reference	Sum of the external reference as a percentage, i.e. the sum of analog/pulse/bus.

[1652]	Feedback [Unit]	Signal value in units from the programmed digital input(s).
[1653]	Digi Pot Reference	View the contribution of the digital potentiometer to the actual reference Feedback.
[1654]	Feedback 1 [Unit]	View the value of Feedback 1. See also par. 20-0*.
[1655]	Feedback 2 [Unit]	View the value of Feedback 2. See also par. 20-0*.
[1656]	Feedback 3 [Unit]	View the value of Feedback 3. See also par. 20-0*.
[1658]	PID Output [%]	Returns the Drive Closed Loop PID controller output value in percent.
[1659]	Adjusted Setpoint	Displays the actual operating set-point after it is modified by flow compensation. See parameters 22-8*.
[1660]	Digital Input	Displays the status of the digital inputs. Signal low = 0; Signal high = 1. Regarding order, see par. 16-60. Bit 0 is at the extreme right.
[1661]	Terminal 53 Switch Setting	Setting of input terminal 53. Current = 0; Voltage = 1.
[1662]	Analog Input 53	Actual value at input 53 either as a reference or protection value.
[1663]	Terminal 54 Switch Setting	Setting of input terminal 54. Current = 0; Voltage = 1.
[1664]	Analog Input 54	Actual value at input 54 either as reference or protection value.
[1665]	Analog Output 42 [mA]	Actual value at output 42 in mA. Use par. 6-50 to select the variable to be represented by output 42.
[1666]	Digital Output [bin]	Binary value of all digital outputs.
[1667]	Freq. Input #29 [Hz]	Actual value of the frequency applied at terminal 29 as a pulse input.
[1668]	Freq. Input #33 [Hz]	Actual value of the frequency applied at terminal 33 as a pulse input.
[1669]	Pulse Output #27 [Hz]	Actual value of pulses applied to terminal 27 in digital output mode.
[1670]	Pulse Output #29 [Hz]	Actual value of pulses applied to terminal 29 in digital output mode.
[1671]	Relay Output [bin]	View the setting of all relays.
[1672]	Counter A	View the present value of Counter A.
[1673]	Counter B	View the present value of Counter B.
[1675]	Analog input X30/11	Actual value of the signal on input X30/11 (General Purpose I/O Card. Option)
[1676]	Analog input X30/12	Actual value of the signal on input X30/12 (General Purpose I/O Card. Optional)
[1677]	Analog output X30/8 [mA]	Actual value at output X30/8 (General Purpose I/O Card. Optional) Use Par. 6-60 to select the variable to be shown.
[1680]	Fieldbus CTW 1	Control word (CTW) received from the Bus Master.
[1682]	Fieldbus REF 1	Main reference value sent with control word via the serial communications network e.g. from the BMS, PLC or other master controller.
[1684]	Comm. Option STW	Extended fieldbus communication option status word.
[1685]	FC Port CTW 1	Control word (CTW) received from the Bus Master.
[1686]	FC Port REF 1	Status word (STW) sent to the Bus Master.
[1690]	Alarm Word	One or more alarms in a Hex code (used for serial communications)
[1691]	Alarm Word 2	One or more alarms in a Hex code (used for serial communications)
[1692]	Warning Word	One or more warnings in a Hex code (used for serial communications)
[1693]	Warning Word 2	One or more warnings in a Hex code (used for serial communications)
[1694]	Ext. Status Word	One or more status conditions in a Hex code (used for serial communications)
[1695]	Ext. Status Word 2	One or more status conditions in a Hex code (used for serial communications)
[1696]	Maintenance Word	The bits reflect the status for the programmed Preventive Maintenance Events in parameter group 23-1*
[1830]	Analog Input X42/1	Shows the value of the signal applied to terminal X42/1 on the Analog I/O card.
[1831]	Analog Input X42/3	Shows the value of the signal applied to terminal X42/3 on the Analog I/O card.
[1832]	Analog Input X42/5	Shows the value of the signal applied to terminal X42/5 on the Analog I/O card.

[1833]	Analog Out X42/7 [V]	Shows the value of the signal applied to terminal X42/7 on the Analog I/O card.
[1834]	Analog Out X42/9 [V]	Shows the value of the signal applied to terminal X42/9 on the Analog I/O card.
[1835]	Analog Out X42/11 [V]	Shows the value of the signal applied to terminal X42/11 on the Analog I/O card.
[2117]	Ext. 1 Reference [Unit]	The value of the reference for extended Closed Loop Controller 1
[2118]	Ext. 1 Feedback [Unit]	The value of the feedback signal for extended Closed Loop Controller 1
[2119]	Ext. 1 Output [%]	The value of the output from extended Closed Loop Controller 1
[2137]	Ext. 2 Reference [Unit]	The value of the reference for extended Closed Loop Controller 2
[2138]	Ext. 2 Feedback [Unit]	The value of the feedback signal for extended Closed Loop Controller 2
[2139]	Ext. 2 Output [%]	The value of the output from extended Closed Loop Controller 2
[2157]	Ext. 3 Reference [Unit]	The value of the reference for extended Closed Loop Controller 3
[2158]	Ext. 3 Feedback [Unit]	The value of the feedback signal for extended Closed Loop Controller 3
[2159]	Ext. Output [%]	The value of the output from extended Closed Loop Controller 3
[2230]	No-Flow Power	The calculated No Flow Power for the actual operating speed
[2580]	Cascade Status	Status for the operation of the Cascade Controller
[2581]	Pump Status	Status for the operation of each individual pump controlled by the Cascade Controller
[2791]	Cascade Reference	Reference output for use with follower drives.
[2792]	% Of Total Capacity	Readout parameter to show the system operating point as a % capacity of total system capacity.
[2793]	Cascade Option Status	Readout parameter to show the status of the cascade system.

0-21 Display Line 1.2 Small

8

Option:	Function:
	Select a variable for display in line 1, middle position.
[1662] * Analog input 53	The options are the same as those listed for par. 0-20 <i>Display Line 1.1 Small</i> .

0-22 Display Line 1.3 Small

Option:	Function:
	Select a variable for display in line 1, right position.
[1614] * Motor Current	The options are the same as those listed for par. 0-20 <i>Display Line 1.1 Small</i> .

0-23 Display Line 2 Large

Option:	Function:
	Select a variable for display in line 2.
[1615] * Frequency	The options are the same as those listed for par. 0-20 <i>Display Line 1.1 Small</i>

0-24 Display Line 3 Large

Option:	Function:
[1652] * Feedback [Unit]	The options are the same as those listed for par. 0-20 <i>Display Line 1.1 Small</i> .
	Select a variable for display in line 2.

0-37 Display Text 1

Range:

0* [0 - 0]

Function:

In this parameter it is possible to write an individual text string for display in the or to be read via serial communication. If to be displayed permanently select Display Text 1 in par. 0-20 *Display Line 1.1 Small*, par. 0-21 *Display Line 1.2 Small*, par. 0-22 *Display Line 1.3 Small*, par. 0-23 *Display Line 2 Large* or par. 0-24 *Display Line 3 Large*. Use the ▲ or ▼ buttons on the to change a character. Use the ◀ and ▶ buttons to move the cursor. When a character is highlighted by the cursor, it can be changed. Use the ▲ or ▼ buttons on the to change a character. A character can be inserted by placing the cursor between two characters and pressing ▲ or ▼.

0-38 Display Text 2

Range:

0* [0 - 0]

Function:

In this parameter it is possible to write an individual text string for display in the or to be read via serial communication. If to be displayed permanently select Display Text 2 in par. 0-20 *Display Line 1.1 Small*, par. 0-21 *Display Line 1.2 Small*, par. 0-22 *Display Line 1.3 Small*, par. 0-23 *Display Line 2 Large* or par. 0-24 *Display Line 3 Large*. Use the ▲ or ▼ buttons on the to change a character. Use the ◀ and ▶ buttons to move the cursor. When a character is highlighted by the cursor, this character can be changed. A character can be inserted by placing the cursor between two characters and pressing ▲ or ▼.

0-39 Display Text 3

Range:

0* [0 - 0]

Function:

In this parameter it is possible to write an individual text string for display in the or to be read via serial communication. If to be displayed permanently select Display Text 3 in par. 0-20 *Display Line 1.1 Small*, par. 0-21 *Display Line 1.2 Small*, par. 0-22 *Display Line 1.3 Small*, par. 0-23 *Display Line 2 Large* or par. 0-24 *Display Line 3 Large*. Use the ▲ or ▼ buttons on the to change a character. Use the ◀ and ▶ buttons to move the cursor. When a character is highlighted by the cursor, this character can be changed. A character can be inserted by placing the cursor between two characters and pressing ▲ or ▼.

0-70 Set Date and Time

Range:

2000-01-01 [2000-01-01 00:00]
00:00 –
2099-12-01
23:59 *

Function:

Sets the date and time of the internal clock. The format to be used is set in par. 0-71 and 0-72.



NB!
This parameter does not display the actual time. This can be read in par. 0-89. The clock will not begin counting until a setting different from default has been made.

0-71 Date Format

Option:

[0] * YYYY-MM-DD
[1] DD-MM-YYYY
[2] MM/DD/YYYY

Function:

Sets the date format to be used in the LCP.
Sets the date format to be used in the LCP.
Sets the date format to be used in the LCP.

0-72 Time Format

Option:

Function:

Sets the time format to be used in the .

[0] * 24 h

[1] 12 h

0-74 DST/Summertime

Option:

Function:

Choose how Daylight Saving Time/Summertime should be handled. For manual DST/Summertime enter the start date and end date in par. 0-76 *DST/Summertime Start* and par. 0-77 *DST/Summertime End*.

[0] * Off

[2] Manual

0-76 DST/Summertime Start

Range:

Function:

Application [Application dependant]
dependent*

Sets the date and time when summertime/DST starts. The date is programmed in the format selected in par. 0-71 *Date Format*.

0-77 DST/Summertime End

Range:

Function:

Application [Application dependant]
dependent*

Sets the date and time when summertime/DST ends. The date is programmed in the format selected in par. 0-71 *Date Format*.

8.2.3 General Settings, 1-0*

Define whether the frequency converter operates in open loop or closed loop.

1-00 Configuration Mode

Option:

[0] * Open Loop

Function:

Motor speed is determined by applying a speed reference or by setting desired speed when in Hand Mode.
Open Loop is also used if the frequency converter is part of a closed loop control system based on an external PID controller providing a speed reference signal as output.

[3] Closed Loop

Motor Speed will be determined by a reference from the built-in PID controller varying the motor speed as part of a closed loop control process (e.g. constant pressure or flow). The PID controller must be configured in par. 20-** or via the Function Setups accessed by pressing the [Quick Menus] button.



NB!

This parameter cannot be changed when motor is running.



NB!

When set for Closed Loop, the commands Reversing and Start Reversing will not reverse the direction of the motor.

1-20 Motor Power [kW]

Range:

Application [Application dependant]
dependent*

Function:

Enter the nominal motor power in kW according to the motor nameplate data. The default value corresponds to the nominal rated output of the unit.
This parameter cannot be adjusted while the motor is running. Depending on the choices made in par. 0-03 *Regional Settings*, either par. 1-20 *Motor Power [kW]* or par. 1-21 *Motor Power [HP]* is made invisible.

1-22 Motor Voltage

Range:

Application [Application dependant]
dependent*

Function:

Enter the nominal motor voltage according to the motor nameplate data. The default value corresponds to the nominal rated output of the unit.
This parameter cannot be adjusted while the motor is running.

1-23 Motor Frequency

Range:

Application [20 - 1000 Hz]
dependent*

Function:

Select the motor frequency value from the motor nameplate data. For 87 Hz operation with 230/400 V motors, set the nameplate data for 230 V/50 Hz. Adapt par. 4-13 *Motor Speed High Limit [RPM]* and par. 3-03 *Maximum Reference* to the 87 Hz application.



NB!

This parameter cannot be adjusted while the motor is running.

1-24 Motor Current

Range:	Function:
Application [Application dependant] dependent*	Enter the nominal motor current value from the motor nameplate data. This data is used for calculating motor torque, motor thermal protection etc.



NB!
This parameter cannot be adjusted while the motor is running.

1-25 Motor Nominal Speed

Range:	Function:
Application [100 - 60000 RPM] dependent*	Enter the nominal motor speed value from the motor nameplate data. This data is used for calculating automatic motor compensations.



NB!
This parameter cannot be changed while the motor is running.

1-29 Automatic Motor Adaptation (AMA)

Option:	Function:
	The AMA function optimizes dynamic motor performance by automatically optimizing the advanced motor parameters par. 1-30 <i>Stator Resistance (Rs)</i> to par. 1-35 <i>Main Reactance (Xh)</i> while the motor is stationary.
[0] * Off	No function
[1] Enable complete AMA	performs AMA of the stator resistance R_s , the rotor resistance R_r , the stator leakage reactance X_{L1} , the rotor leakage reactance X_{L2} and the main reactance X_{h1} .
[2] Enable reduced AMA	performs a reduced AMA of the stator resistance R_s in the system only. Select this option if an LC filter is used between the frequency converter and the motor.

Activate the AMA function by pressing [Hand on] after selecting [1] or [2]. See also the section *Automatic Motor Adaptation*. After a normal sequence, the display will read: "Press [OK] to finish AMA". After pressing the [OK] key the frequency converter is ready for operation.

Note:

- For the best adaptation of the frequency converter, run AMA on a cold motor
- AMA cannot be performed while the motor is running



NB!
It is important to set motor par. 1-2* Motor Data correctly, since these form part of the AMA algorithm. An AMA must be performed to achieve optimum dynamic motor performance. It may take up to 10 min., depending on motor power rating.



NB!
Avoid generating external torque during AMA

 **NB!**
 If one of the settings in par. 1-2* Motor Data is changed, par. 1-30 *Stator Resistance (Rs)* to par. 1-39 *Motor Poles*, the advanced motor parameters, will return to default setting.
 This parameter cannot be adjusted while the motor is running

 **NB!**
 Full AMA should be run without filter only while reduced AMA should be run with filter.

See section: *Application Examples > Automatic Motor Adaptation* in the Design Guide.

8.2.4 3-0* Reference Limits

Parameters for setting the reference unit, limits and ranges.

3-02 Minimum Reference

Range:

Application [Application dependant]
 dependent*

Function:

Enter the Minimum Reference. The Minimum Reference is the lowest value obtainable by summing all references. The Minimum Reference value and unit matches the configuration choice made in par. 1-00 *Configuration Mode* and par. 20-12 *Reference/Feedback Unit*, respectively.

 **NB!**
 This parameter is used in open loop only.

3-03 Maximum Reference

Range:

Application [Application dependant]
 dependent*

Function:

Enter the Maximum Reference. The Maximum Reference is the highest value obtainable by summing all references. The Maximum Reference value and unit matches the configuration choice made in par. 1-00 *Configuration Mode* and par. 20-12 *Reference/Feedback Unit*, respectively.

 **NB!**
 This parameter is used in open loop only.

3-10 Preset Reference

Array [8]

Range:

0.00 %* [-100.00 - 100.00 %]

Function:

Enter up to eight different preset references (0-7) in this parameter, using array programming. The preset reference is stated as a percentage of the value Ref_{MAX} (par. 3-03 *Maximum Reference*, for closed loop see par. 20-14 *Maximum Reference/Feedb.*). When using preset references, select Preset ref. bit 0 / 1 / 2 [16], [17] or [18] for the corresponding digital inputs in parameter group 5-1* Digital Inputs.

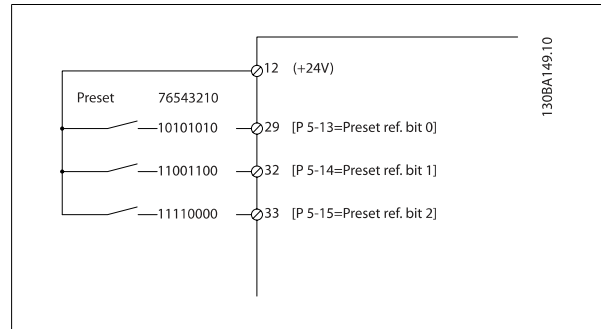
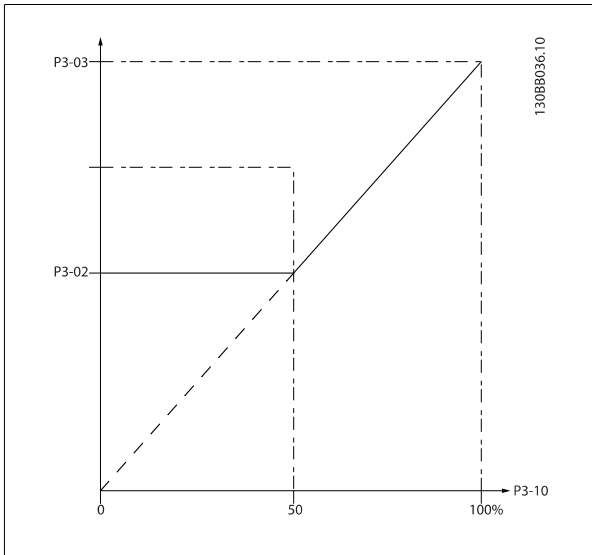

8

3-41 Ramp 1 Ramp Up Time

Range:

Application [Application dependant]
dependent*

Function:

Enter the ramp-up time, i.e. the acceleration time from 0 RPM to par. 1-25 *Motor Nominal Speed*. Choose a ramp-up time such that the output current does not exceed the current limit in par. 4-18 *Current Limit* during ramping. See ramp-down time in par. 3-42 *Ramp 1 Ramp Down Time*.

$$par.3 - 41 = \frac{tacc \times nnorm [par.1 - 25]}{ref [rpm]} [s]$$

3-42 Ramp 1 Ramp Down Time

Range:

Application [Application dependant]
dependent*

Function:

Enter the ramp-down time, i.e. the deceleration time from par. 1-25 *Motor Nominal Speed* to 0 RPM. Choose a ramp-down time such that no over-voltage arises in the inverter due to regenerative operation of the motor, and such that the generated current does not exceed the current limit set in par. 4-18 *Current Limit*. See ramp-up time in par. 3-41 *Ramp 1 Ramp Up Time*.

$$par.3 - 42 = \frac{tdec \times nnorm [par.1 - 25]}{ref [rpm]} [s]$$

3-84 Initial Ramp Time

Range:

0 s* [0 – 60 s]

Function:

Enter the initial ramp up time from zero speed to Motor Speed Low Limit, par. 4-11 or 4-12. Submersible deep well pumps can be damaged by running below minimum speed. A fast ramp time below minimum pump speed is recommended. This parameter may be applied as a fast ramp rate from zero speed to Motor Speed Low Limit.

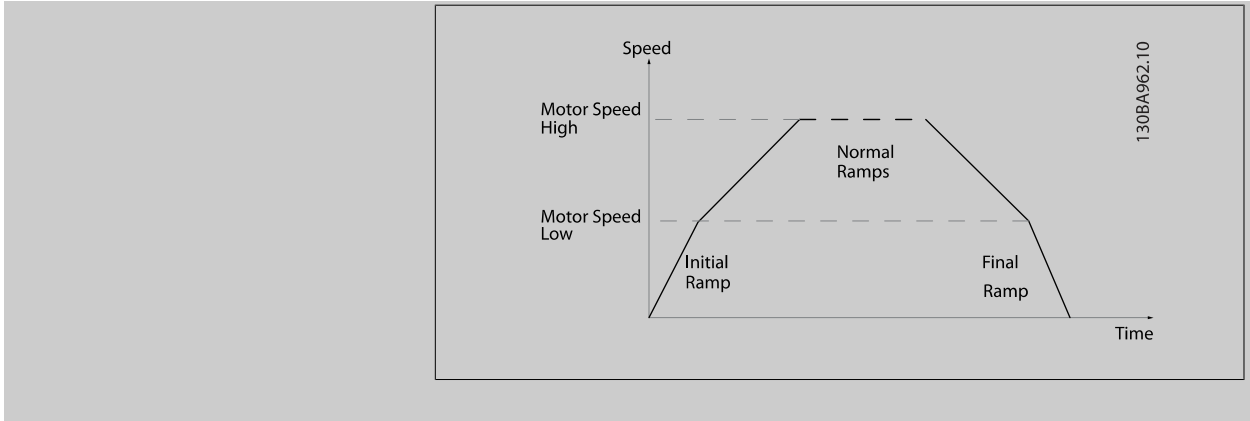

3-85 Check Valve Ramp Time

Range:

0 s* [0 – 60 s]

Function:

In order to protect ball check valves in a stop situation, the check valve ramp can be utilized as a slow ramp rate from par. 4-11 *Motor Speed Low Limit [RPM]* or par. 4-12 *Motor Speed Low Limit [Hz]*, to Check Valve Ramp End Speed, set by the user in par. 3-86 or par. 3-87. When par. 3-85 is different from 0 seconds, the Check Valve Ramp Time is effectuated and will be used to ramp down the speed from Motor Speed Low Limit to the Check Valve End Speed in par. 3-86 or par. 3-87.

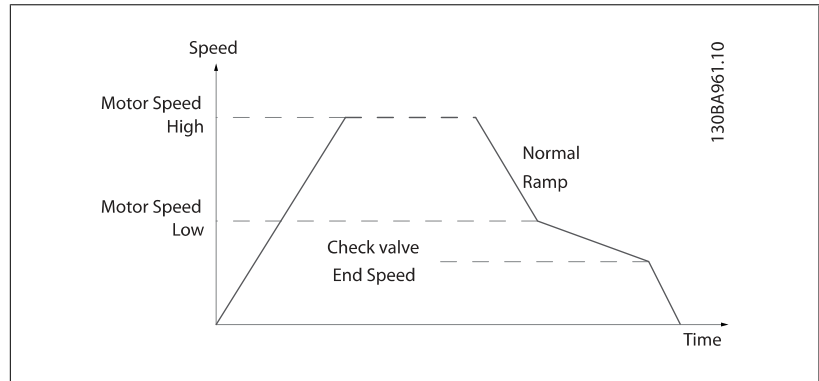

3-86 Check Valve Ramp End Speed [RPM]

Range:

0 [RPM]* [0 – Motor Speed Low Limit [RPM]]

Function:

Set the speed in [RPM] below Motor Speed Low Limit where the Check Valve is expected to be closed and the Check Valve no longer shall be active.

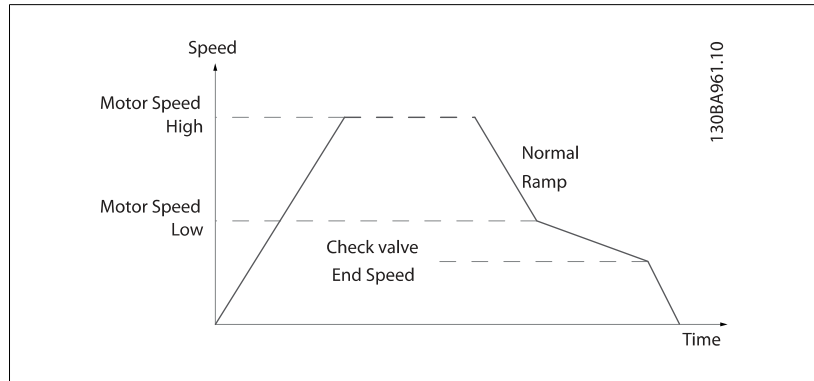

3-87 Check Valve Ramp End Speed [Hz]

Range:

0 [Hz]* [0 – Motor Speed Low Limit [Hz]]

Function:

Set the speed in [Hz] below Motor Speed Low Limit where the Check Valve Ramp will no longer be active.

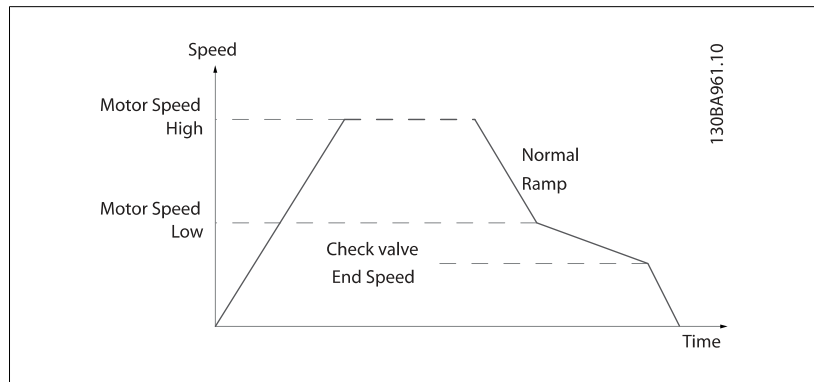

8

3-88 Final Ramp Time

Range:

0 [s]* [0 – 60 [s]]

Function:

Enter the Final Ramp Time to be used when ramping down from Motor Speed Low Limit, par. 4-11 or 4-12, to zero speed.

Submersible deep well pumps can be damaged by running below minimum speed. A fast ramp time below minimum pump speed is recommended. This parameter may be applied as a fast ramp rate from Motor Speed Low Limit to zero speed.

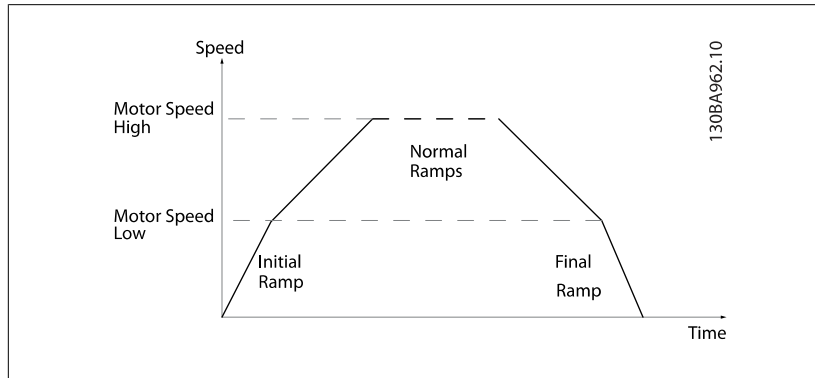

8.2.5 4-** Limits and Warnings

Parameter group for configuring limits and warnings.

4-11 Motor Speed Low Limit [RPM]

Range:

Application [Application dependant]
dependent*

Function:

Enter the minimum limit for motor speed. The Motor Speed Low Limit can be set to correspond to the manufacturer's recommended minimum motor speed. The Motor Speed Low Limit must not exceed the setting in par. 4-13 *Motor Speed High Limit [RPM]*.

4-13 Motor Speed High Limit [RPM]

Range:

Application [Application dependant]
dependent*

Function:

Enter the maximum limit for motor speed. The Motor Speed High Limit can be set to correspond to the manufacturer's maximum rated motor. The Motor Speed High Limit must exceed the setting in par. 4-11 *Motor Speed Low Limit [RPM]*. Only par. 4-11 *Motor Speed Low Limit [RPM]* or par. 4-12 *Motor Speed Low Limit [Hz]* will be displayed depending on other parameters in the Main Menu and depending on default settings dependant on global location.



NB!

Max. output frequency cannot exceed 10% of the inverter switching frequency (par. 14-01 *Switching Frequency*).



NB!

Any changes in par. 4-13 *Motor Speed High Limit [RPM]* will reset the value in par. 4-53 *Warning Speed High* to the same value as set in par. 4-13 *Motor Speed High Limit [RPM]*.

8.2.6 5-** Digital In/Out

Parameter group for configuring the digital input and output.

5-01 Terminal 27 Mode

Option:	Function:
[0] * Input	Defines terminal 27 as a digital input.
[1] Output	Defines terminal 27 as a digital output.

Please note that this parameter cannot be adjusted while the motor is running.

8.2.7 5-1* Digital Inputs

Parameters for configuring the input functions for the input terminals.

The digital inputs are used for selecting various functions in the frequency converter. All digital inputs can be set to the following functions:

Digital input function	Select	Terminal
No operation	[0]	All *term 32, 33
Reset	[1]	All
Coast inverse	[2]	All
Coast and reset inverse	[3]	All
DC-brake inverse	[5]	All
Stop inverse	[6]	All
External interlock	[7]	All
Start	[8]	All *term 18
Latched start	[9]	All
Reversing	[10]	All *term 19
Start reversing	[11]	All
Jog	[14]	All *term 29
Preset reference on	[15]	All
Preset ref bit 0	[16]	All
Preset ref bit 1	[17]	All
Preset ref bit 2	[18]	All
Freeze reference	[19]	All
Freeze output	[20]	All
Speed up	[21]	All
Speed down	[22]	All
Set-up select bit 0	[23]	All
Set-up select bit 1	[24]	All
Pulse input	[32]	term 29, 33
Ramp bit 0	[34]	All
Mains failure inverse	[36]	All
Run Permissive	[52]	
Hand start	[53]	
Auto start	[54]	
DigiPot Increase	[55]	All
DigiPot Decrease	[56]	All
DigiPot Clear	[57]	All
Counter A (up)	[60]	29, 33
Counter A (down)	[61]	29, 33
Reset Counter A	[62]	All
Counter B (up)	[63]	29, 33
Counter B (down)	[64]	29, 33
Reset Counter B	[65]	All
Sleep Mode	[66]	
Reset Maintenance Word	[78]	
Lead Pump Start	[120]	
Lead Pump Alternation	[121]	
Pump 1 Interlock	[130]	
Pump 2 Interlock	[131]	
Pump 3 Interlock	[132]	

All = Terminals 18, 19, 27, 29, 32, X30/2, X30/3, X30/4. X30/ are the terminals on MCB 101.

Functions dedicated to only one digital input are stated in the associated parameter.

All digital inputs can be programmed to these functions:

[0]	No operation	No reaction to signals transmitted to terminal.
[1]	Reset	Resets frequency converter after a TRIP/ALARM. Not all alarms can be reset.
[2]	Coast inverse	Leaves motor in free mode. Logic '0' => coasting stop. (Default Digital input 27): Coasting stop, inverted input (NC).
[3]	Coast and reset inverse	Reset and coasting stop Inverted input (NC). Leaves motor in free mode and resets the frequency converter. Logic '0' => coasting stop and reset.
[5]	DC-brake inverse	Inverted input for DC braking (NC).

Stops motor by energizing it with a DC current for a certain time period. See par. 2-01 to par. 2-03. The function is only active when the value in par. 2-02 is different from 0. Logic '0' => DC braking.

[6] Stop inverse Stop Inverted function. Generates a stop function when the selected terminal goes from logical level '1' to '0'. The stop is performed according to the selected ramp time (par. 3-42 and par. 3-52).



NB!

When the frequency converter is at the torque limit and has received a stop command, it may not stop by itself. To ensure that the frequency converter stops, configure a digital output to *Torque limit & stop* [27] and connect this digital output to a digital input that is configured as coast.

[7] External Interlock Same function as Coasting stop, inverse, but External Interlock generates the alarm message 'external fault' on the display when the terminal which is programmed for Coast Inverse is logic '0'. The alarm message will also be active via digital outputs and relay outputs, if programmed for External Interlock. The alarm can be reset using a digital input or the [RESET] key if the cause for the External Interlock has been removed. A delay can be programmed in par. 22-00, External Interlock Time. After applying a signal to the input, the reaction described above will be delayed with the time set in par. 22-00.

[8] Start Select start for a start/stop command. Logic '1' = start, logic '0' = stop.
(Default Digital input 18)

[9] Latched start Motor starts, if a pulse is applied for min. 2 ms. Motor stops when Stop inverse is activated

[10] Reversing Changes direction of motor shaft rotation. Select Logic '1' to reverse. The reversing signal only changes the direction of rotation. It does not activate the start function. Select both directions in par. 4-10 *Motor Speed Direction*.
(Default Digital input 19).

[11] Start reversing Used for start/stop and for reversing on the same wire. Signals on start are not allowed at the same time.

[14] Jog Used for activating jog speed. See par. 3-11.
(Default Digital input 29)

[15] Preset reference on Used for shifting between external reference and preset reference. It is assumed that *External/preset* [1] has been selected in par. 3-04. Logic '0' = external reference active; logic '1' = one of the eight preset references is active.

[16] Preset ref bit 0 Enables a choice between one of the eight preset references according to the table below.

[17] Preset ref bit 1 Enables a choice between one of the eight preset references according to the table below.

[18] Preset ref bit 2 Enables a choice between one of the eight preset references according to the table below.

Preset ref. bit	2	1	0
Preset ref. 0	0	0	0
Preset ref. 1	0	0	1
Preset ref. 2	0	1	0
Preset ref. 3	0	1	1
Preset ref. 4	1	0	0
Preset ref. 5	1	0	1
Preset ref. 6	1	1	0
Preset ref. 7	1	1	1

[19] Freeze ref Freezes actual reference. The frozen reference is now the point of enable/condition for Speed up and Speed down to be used. If Speed up/down is used, the speed change always follows ramp 2 (par. 3-51 and 3-52) in the range 0 - par. 3-03 *Maximum Reference*.

[20] Freeze output Freezes actual motor frequency (Hz). The frozen motor frequency is now the point of enable/condition for Speed up and Speed down to be used. If Speed up/down is used, the speed change always follows ramp 2 (par. 3-51 and 3-52) in the range 0 - par. 1-23 *Motor Frequency*.



NB!

When Freeze output is active, the frequency converter cannot be stopped via a low 'start [13]' signal. Stop the frequency converter via a terminal programmed for Coasting inverse [2] or Coast and reset, inverse [3].

[21]	Speed up	For digital control of the up/down speed is desired (motor potentiometer). Activate this function by selecting either Freeze reference or Freeze output. When Speed up is activated for less than 400 msec. the resulting reference will be increased by 0.1 %. If Speed up is activated for more than 400 msec. the resulting reference will ramp according to Ramp 1 in par. 3-41.
[22]	Speed down	Same as Speed up [21].
[23]	Set-up select bit 0	Selects one of the four set-ups. Set par. 0-10 <i>Active Set-up</i> to Multi Set-up.
[24]	Set-up select bit 1	Same as Set-up select bit 0 [23]. (Default Digital input 32)
[32]	Pulse input	Select Pulse input when using a pulse sequence as either reference or feedback. Scaling is done in par. group 5-5*.
[34]	Ramp bit 0	Select which ramp to use. Logic "0" will select ramp 1 while logic "1" will select ramp 2.
[36]	Mains failure inverse	Activates par. 14-10 <i>Mains Failure</i> . Mains failure inverse is active in the Logic "0" situation.
[52]	Run Permissive	The input terminal, for which the Run permissive has been programmed must be logic "1" before a start command can be accepted. Run permissive has a logic 'AND' function related to the terminal which is programmed for <i>START</i> [8], <i>Jog</i> [14] or <i>Freeze Output</i> [20], which means that in order to start running the motor, both conditions must be fulfilled. If Run Permissive is programmed on multiple terminals, Run permissive needs only be logic '1' on one of the terminals for the function to be carried out. The digital output signal for Run Request (<i>Start</i> [8], <i>Jog</i> [14] or <i>Freeze output</i> [20]) programmed in par. 5-3* Digital outputs, or par. 5-4* Relays, will not be affected by Run Permissive.
[53]	Hand start	A signal applied will put the frequency converter into Hand mode as if button <i>Hand On</i> on the LCP has been pressed and a normal stop command will be overridden. If disconnecting the signal, the motor will stop. To make any other start commands valid, another digital input must be assign to <i>Auto Start</i> and a signal applied to this. The <i>Hand On</i> and <i>Auto On</i> buttons on the LCP has no impact. The <i>Off</i> button on the LCP will override <i>Hand Start</i> and <i>Auto Start</i> . Press either the <i>Hand On</i> or <i>Auto On</i> button to make <i>Hand Start</i> and <i>Auto Start</i> active again. If no signal on neither <i>Hand Start</i> nor <i>Auto Start</i> , the motor will stop regardless of any normal Start command applied. If signal applied to both <i>Hand Start</i> and <i>Auto Start</i> , the function will be <i>Auto Start</i> . If pressing the <i>Off</i> button on the LCP the motor will stop regardless of signals on <i>Hand Start</i> and <i>Auto Start</i> .
[54]	Auto start	A signal applied will put the frequency converter into Auto mode as if the LCP button <i>Auto On</i> has been pressed. See also <i>Hand Start</i> [53]
[55]	DigiPot Increase	Uses the input as an INCREASE signal to the Digital Potentiometer function described in parameter group 3-9*
[56]	DigiPot Decrease	Uses the input as a DECREASE signal to the Digital Potentiometer function described in parameter group 3-9*
[57]	DigiPot Clear	Uses the input to CLEAR the Digital Potentiometer reference described in parameter group 3-9*
[60]	Counter A (up)	(Terminal 29 or 33 only) Input for increment counting in the SLC counter.
[61]	Counter A (down)	(Terminal 29 or 33 only) Input for decrement counting in the SLC counter.
[62]	Reset Counter A	Input for reset of counter A.
[63]	Counter B (up)	(Terminal 29 and 33 only) Input for increment counting in the SLC counter.
[64]	Counter B (down)	(Terminal 29 and 33 only) Input for decrement counting in the SLC counter.
[65]	Reset Counter B	Input for reset of counter B.
[66]	Sleep Mode	Forces frequency converter into Sleep Mode (see par. 22-4*, Sleep Mode). Reacts on the rising edge of signal applied!

[78] Reset Preventive Maintenance Word Resets all data in par. 16-96, Preventive Maintenance Word, to 0.

The below setting options are all related to the Cascade Controller. Wiring diagrams and settings for parameter, see group 25-** for more details.

[120] Lead Pump Start Starts/Stops the Lead Pump (controlled by the frequency converter). A start requires that also a System Start signal has been applied e.g. to one of the digital inputs set for *Start* [8]!

[121] Lead Pump Alternation Forces alternation of the lead pump in a Cascade Controller. *Lead Pump Alternation*, par. 25-50, must be set to either *At Command* [2] or *At Staging or At Command* [3]. *Alternation Event*, par. 25-51, can be set to any of the four options.

[130 - 138] Pump1 Interlock - Pump9 Interlock The function will depend on the setting in par. 25-06, Number of Pumps. If set to *No* [0], then Pump1 refers to the pump controlled by relay RELAY1 etc. If set to *Yes* [1], Pump1 refers to the pump controlled by the frequency converter only (without any of the build in relays involved) and Pump2 to the pump controlled by the relay RELAY1. Variable speed pump (lead) cannot be interlocked in the basic Cascade Controller.

See below table:

Setting in Par. 5-1*	Setting in Par. 25-06	
	[0] No	[1] Yes
[130] Pump1 Interlock	Controlled by RELAY1 (only if not lead pump)	Frequency Converter controlled (cannot be interlocked)
[131] Pump2 Interlock	Controlled by RELAY2	Controlled by RELAY1
[132] Pump3 Interlock	Controlled by RELAY3	Controlled by RELAY2
[133] Pump4 Interlock	Controlled by RELAY4	Controlled by RELAY3
[134] Pump5 Interlock	Controlled by RELAY5	Controlled by RELAY4
[135] Pump6 Interlock	Controlled by RELAY6	Controlled by RELAY5
[136] Pump7 Interlock	Controlled by RELAY7	Controlled by RELAY6
[137] Pump8 Interlock	Controlled by RELAY8	Controlled by RELAY7
[138] Pump9 Interlock	Controlled by RELAY9	Controlled by RELAY8



5-13 Terminal 29 Digital Input

Option: [0] * No Operation **Function:** Same options and functions as par. 5-1* *Digital Inputs*.

5-14 Terminal 32 Digital Input

Same options and functions as par. 5-1*, except for *Pulse input*.

Option: [0] * No operation **Function:**

5-15 Terminal 33 Digital Input

Same options and functions as par. 5-1* *Digital Inputs*.

Option: [0] * No operation **Function:**

5-30 Terminal 27 Digital Output

Same options and functions as par. 5-3*.

Option: [0] * No operation **Function:**

5-40 Function Relay

Array [8]	(Relay 1 [0], Relay 2 [1], Relay 7 [6], Relay 8 [7], Relay 9 [8])
-----------	---

Select options to define the function of the relays.
The selection of each mechanical relay is realized in an array parameter.

[0] *	No Operation
[1]	Control Ready
[2]	Drive Ready
[3]	Drive Ready/Remote
[4]	Stand-by/No Warning
[5]	Running
[6]	Running/No Warning
[8]	Run on Ref./No Warning
[9]	Alarm
[10]	Alarm or Warning
[11]	At Torque Limit
[12]	Out of Current Range
[13]	Below Current, low
[14]	Above Current, high
[15]	Out of Speed Range
[16]	Below Speed, low
[17]	Above Speed, high
[18]	Out of Feedb. Range
[19]	Below Feedback, low
[20]	Above Feedback, high
[21]	Thermal Warning
[25]	Reverse
[26]	Bus OK
[27]	Torque Limit & Stop
[28]	Brake, No Warning
[29]	Brake Ready, No Fault
[30]	Brake Fault (IGBT)
[35]	External Interlock
[36]	Control Word Bit 11
[37]	Control Word Bit 12
[40]	Out of Ref. Range
[41]	Below Reference, low
[42]	Above Ref. high
[45]	Bus ctrl
[46]	Bus ctrl, 1 if timeout
[47]	Bus ctrl, 0 if timeout
[60]	Comparator 0
[61]	Comparator 1
[62]	Comparator 2

[63]	Comparator 3
[64]	Comparator 4
[65]	Comparator 5
[70]	Logic Rule 0
[71]	Logic Rule 1
[72]	Logic Rule 2
[73]	Logic Rule 3
[74]	Logic Rule 4
[75]	Logic Rule 5
[80]	SL Digital Output A
[81]	SL Digital Output B
[82]	SL Digital Output C
[83]	SL Digital Output D
[84]	SL Digital Output E
[85]	SL Digital Output F
[160]	No Alarm
[161]	Running Reverse
[165]	Local Ref. Active
[166]	Remote Ref. Active
[167]	Start Cmd. Active
[168]	Drive in Hand Mode
[169]	Drive in Auto Mode
[180]	Clock Fault
[181]	Prev. Maintenance
[190]	No-Flow
[191]	Dry Pump
[192]	End of Curve
[193]	Sleep Mode
[194]	Broken Belt
[195]	Bypass Valve Control
[199]	Pipe Filling
[211]	Cascade Pump1
[212]	Cascade Pump2
[213]	Cascade Pump3
[223]	Alarm, Trip Locked
[224]	Bypass Mode Active

5-53 Term. 29 High Ref./Feedb. Value

Range:

100.000* [-999999.999 - 999999.999]

Function:

Enter the high reference value [RPM] for the motor shaft speed and the high feedback value, see also par. 5-58 *Term. 33 High Ref./Feedb. Value.*

8.2.8 6-** Analog In/Out

Parameter group for configuration of the analog input and output.

6-00 Live Zero Timeout Time

Range:

10 s* [1 - 99 s]

Function:

Enter the Live Zero Time-out time period. Live Zero Time-out Time is active for analog inputs, i.e. terminal 53 or terminal 54, used as reference or feedback sources. If the reference signal value associated with the selected current input falls below 50% of the value set in par. 6-10 *Terminal 53 Low Voltage*, par. 6-12 *Terminal 53 Low Current*, par. 6-20 *Terminal 54 Low Voltage* or par. 6-22 *Terminal 54 Low Current* for a time period longer than the time set in par. 6-00 *Live Zero Timeout Time*, the function selected in par. 6-01 *Live Zero Timeout Function* will be activated.

6-01 Live Zero Timeout Function

Option:

Function:

Select the time-out function. The function set in par. 6-01 *Live Zero Timeout Function* will be activated if the input signal on terminal 53 or 54 is below 50% of the value in par. 6-10 *Terminal 53 Low Voltage*, par. 6-12 *Terminal 53 Low Current*, par. 6-20 *Terminal 54 Low Voltage* or par. 6-22 *Terminal 54 Low Current* for a time period defined in par. 6-00 *Live Zero Timeout Time*. If several time-outs occur simultaneously, the frequency converter prioritises the time-out functions as follows:

1. par. 6-01 *Live Zero Timeout Function*
2. par. 8-04 *Control Timeout Function*

The output frequency of the frequency converter can be:

- [1] frozen at the present value
- [2] overruled to stop
- [3] overruled to jog speed
- [4] overruled to max. speed
- [5] overruled to stop with subsequent trip

[0] * Off

[1] Freeze output

[2] Stop

[3] Jogging

[4] Max. speed

[5] Stop and trip

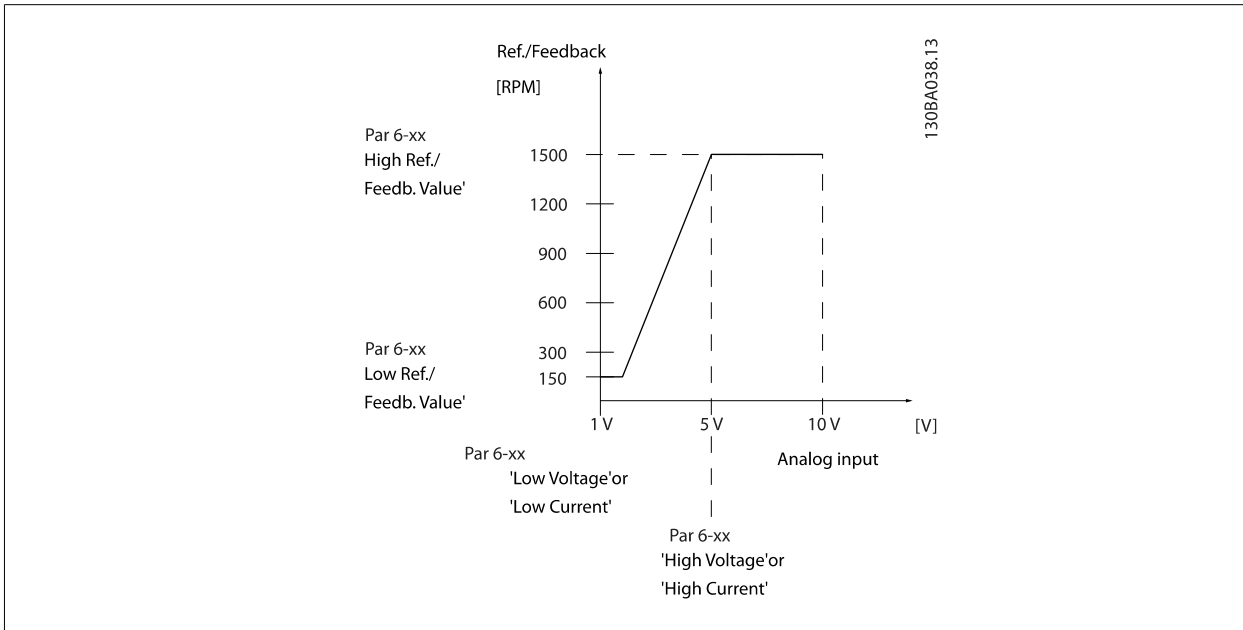

8

6-10 Terminal 53 Low Voltage

Range: 0.07 V* [Application dependant] **Function:** Enter the low voltage value. This analog input scaling value should correspond to the low reference/feedback value set in par. 6-14 *Terminal 53 Low Ref./Feedb. Value*.

6-11 Terminal 53 High Voltage

Range: 10.00 V* [Application dependant] **Function:** Enter the high voltage value. This analog input scaling value should correspond to the high reference/feedback value set in par. 6-15 *Terminal 53 High Ref./Feedb. Value*.

6-14 Terminal 53 Low Ref./Feedb. Value

Range: 0.000* [-999999.999 - 999999.999] **Function:** Enter the analog input scaling value that corresponds to the low voltage/low current set in par. 6-10 *Terminal 53 Low Voltage* and par. 6-12 *Terminal 53 Low Current*.

6-15 Terminal 53 High Ref./Feedb. Value

Range: Application dependent* [-999999.999 - 999999.999] **Function:** Enter the analog input scaling value that corresponds to the high voltage/high current value set in par. 6-11 *Terminal 53 High Voltage* and par. 6-13 *Terminal 53 High Current*.

6-20 Terminal 54 Low Voltage

Range: 0.07 V* [Application dependant] **Function:** Enter the low voltage value. This analog input scaling value should correspond to the low reference/feedback value, set in par. 6-24 *Terminal 54 Low Ref./Feedb. Value*.

6-21 Terminal 54 High Voltage

Range: 10.00 V* [Application dependant] **Function:** Enter the high voltage value. This analog input scaling value should correspond to the high reference/feedback value set in par. 6-25 *Terminal 54 High Ref./Feedb. Value*.

6-24 Terminal 54 Low Ref./Feedb. Value

Range:

0.000* [-999999.999 - 999999.999]

Function:

Enter the analog input scaling value that corresponds to the low voltage/low current value set in par. 6-20 *Terminal 54 Low Voltage* and par. 6-22 *Terminal 54 Low Current*.

6-25 Terminal 54 High Ref./Feedb. Value

Range:

100.000* [-999999.999 - 999999.999]

Function:

Enter the analog input scaling value that corresponds to the high voltage/high current value set in par. 6-21 *Terminal 54 High Voltage* and par. 6-23 *Terminal 54 High Current*.

6-50 Terminal 42 Output

Option:

Function:

Select the function of Terminal 42 as an analog current output. A motor current of 20 mA corresponds to I_{max} .

[0] * No operation

[100] * Output freq. 0-100 : 0 - 100 Hz, (0-20 mA)

[101] Reference Min-Max : Minimum reference - Maximum reference, (0-20 mA)

[102] Feedback +-200% : -200% to +200% of par. 20-14, (0-20 mA)

[103] Motor cur. 0-Imax : 0 - Inverter Max. Current (par. 16-37), (0-20 mA)

[104] Torque 0-Tlim : 0 - Torque limit (par. 4-16), (0-20 mA)

[105] Torque 0-Tnom : 0 - Motor rated torque, (0-20 mA)

[106] Power 0-Pnom : 0 - Motor rated power, (0-20 mA)

[107] * Speed 0-HighLim : 0 - Speed High Limit (par. 4-13 and par. 4-14), (0-20 mA)

[108] Torque +-160%

[109] Out frq 0-Fmax

[113] Ext. Closed Loop 1 : 0 - 100%, (0-20 mA)

[114] Ext. Closed Loop 2 : 0 - 100%, (0-20 mA)

[115] Ext. Closed Loop 3 : 0 - 100%, (0-20 mA)

[116] Cascade Reference

[130] Out frq 0-100 4-20mA : 0 - 100 Hz

[131] Reference 4-20mA : Minimum Reference - Maximum Reference

[132] Feedback 4-20mA : -200% to +200% of par. 20-14 *Maximum Reference/Feedb.*

[133] Motor cur. 4-20mA : 0 - Inverter Max. Current (par. 16-37 *Inv. Max. Current*)

[134] Torq.0-lim 4-20 mA : 0 - Torque limit (par. 4-16)

[135] Torq.0-nom 4-20 mA : 0 - Motor rated torque

[136] Power 4-20mA : 0 - Motor rated power

[137] Speed 4-20mA : 0 - Speed High Limit (4-13 and 4-14)

[138] Torque 4-20mA

[139] Bus ctrl. : 0 - 100%, (0-20 mA)

[140] Bus ctrl. 4-20 mA : 0 - 100%

[141]	Bus ctrl t.o.	: 0 - 100%, (0-20 mA)
[142]	Bus ctrl t.o. 4-20mA	: 0 - 100%
[143]	Ext. CL 1 4-20mA	: 0 - 100%
[144]	Ext. CL 2 4-20mA	: 0 - 100%
[145]	Ext. CL 3 4-20mA	: 0 - 100%
[146]	Cascade Ref. 4-20mA	
[150]	Out frq 0-Fmax 4-20mA	

NB!

Values for setting the Minimum Reference is found in open loop par. 3-02 *Minimum Reference* and for closed loop par. 20-13 *Minimum Reference/Feedb.* - values for maximum reference for open loop is found in par. 3-03 *Maximum Reference* and for closed loop par. 20-14 *Maximum Reference/Feedb.*

6-51 Terminal 42 Output Min Scale

Range:	Function:
0.00 %* [0.00 - 200.00 %]	Scale for the minimum output (0 or 4 mA) of the analogue signal at terminal 42. Set the value to be the percentage of the full range of the variable selected in par. 6-50 <i>Terminal 42 Output</i> .

6-52 Terminal 42 Output Max Scale

Range:	Function:
100.00 %* [0.00 - 200.00 %]	Scale for the maximum output (20 mA) of the analog signal at terminal 42. Set the value to be the percentage of the full range of the variable selected in par. 6-50 <i>Terminal 42 Output</i> .

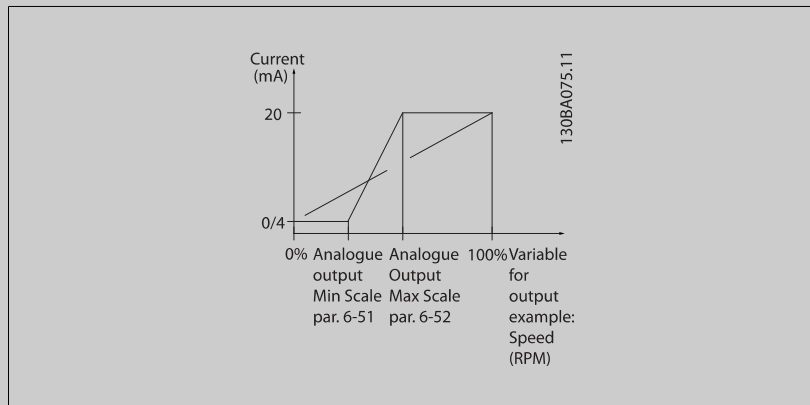

It is possible to get a value lower than 20 mA at full scale by programming values >100% by using a formula as follows:

$$20 \text{ mA} | \text{desired maximum current} \times 100 \%$$

$$\text{i.e. } 10 \text{ mA} : \frac{20 \text{ mA}}{10 \text{ mA}} \times 100 \% = 200 \%$$

EXAMPLE 1:

Variable value= OUTPUT FREQUENCY, range = 0-100 Hz

Range needed for output = 0-50 Hz

Output signal 0 or 4 mA is needed at 0 Hz (0% of range) - set par. 6-51 *Terminal 42 Output Min Scale* to 0%

Output signal 20 mA is needed at 50 Hz (50% of range) - set par. 6-52 *Terminal 42 Output Max Scale* to 50%

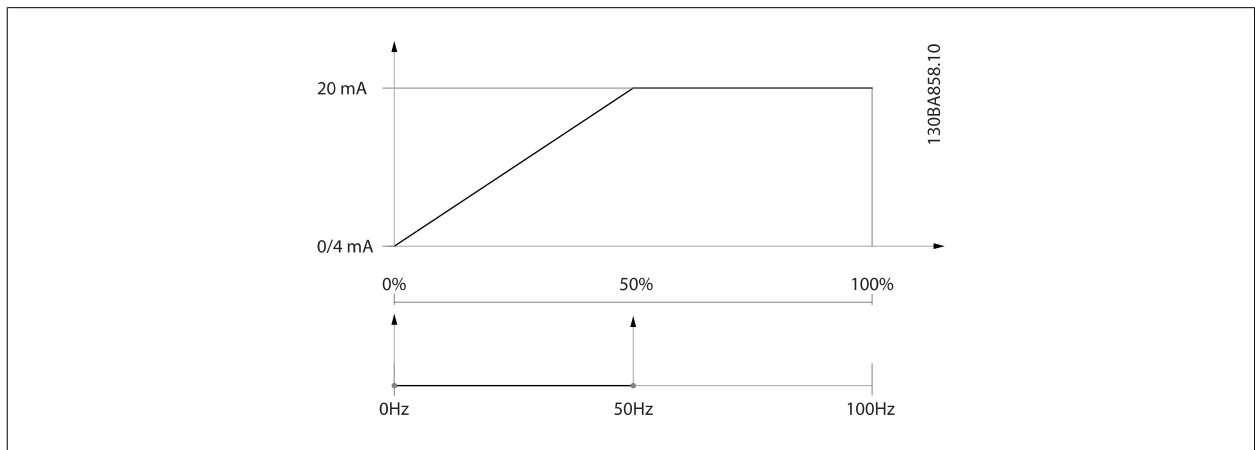

EXAMPLE 2:

Variable= FEEDBACK, range= -200% to +200%

Range needed for output= 0-100%

Output signal 0 or 4 mA is needed at 0% (50% of range) - set par. 6-51 *Terminal 42 Output Min Scale* to 50%

Output signal 20 mA is needed at 100% (75% of range) - set par. 6-52 *Terminal 42 Output Max Scale* to 75%

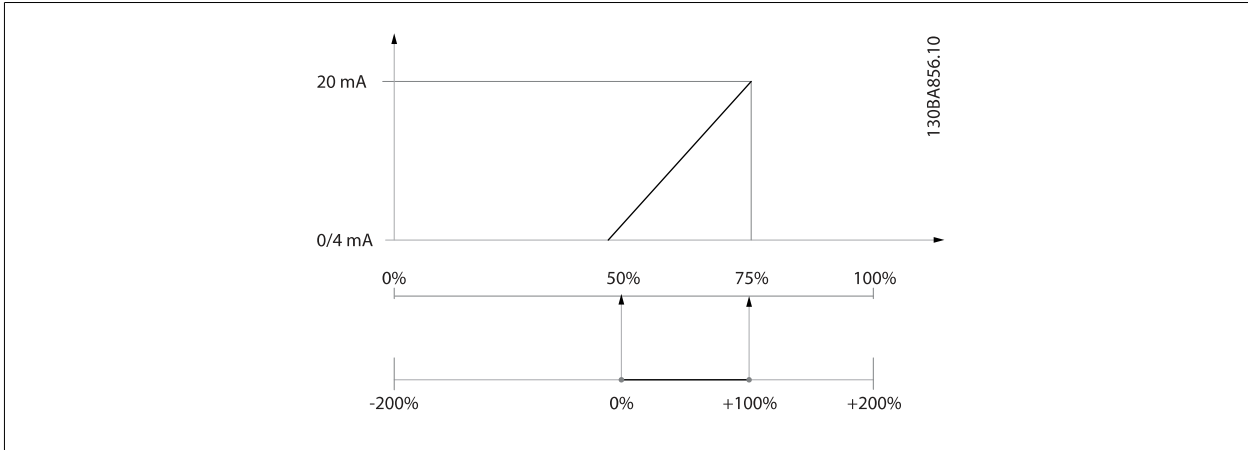

EXAMPLE 3:

Variable value= REFERENCE, range= Min ref - Max ref

Range needed for output= Min ref (0%) - Max ref (100%), 0-10 mA

Output signal 0 or 4 mA is needed at Min ref - set par. 6-51 *Terminal 42 Output Min Scale* to 0%

Output signal 10 mA is needed at Max ref (100% of range) - set par. 6-52 *Terminal 42 Output Max Scale* to 200%

(20 mA / 10 mA x 100%=200%).

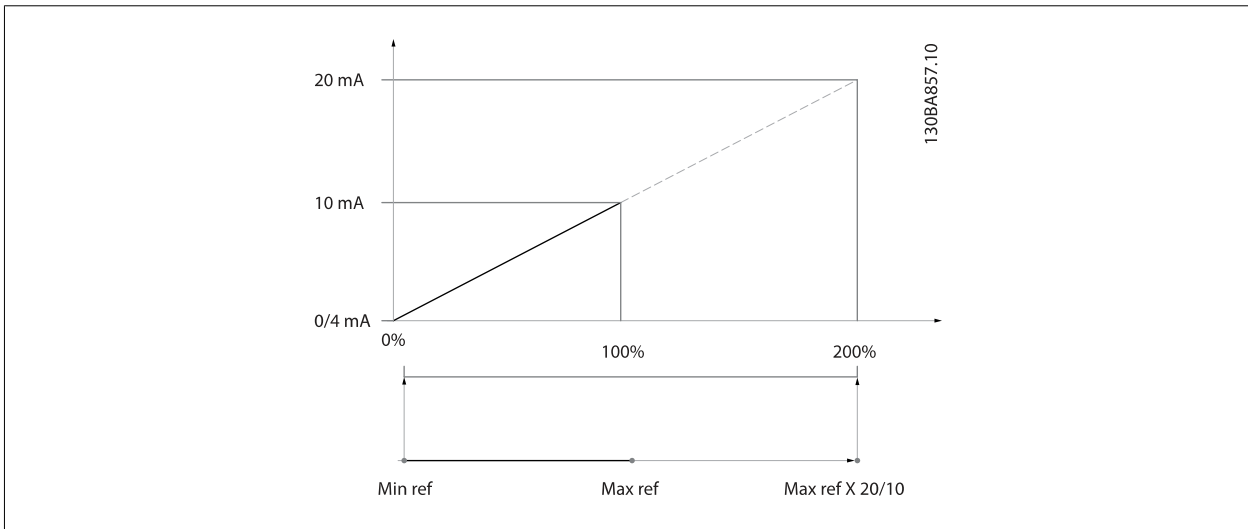

8.2.9 Drive Closed Loop, 20-**

This parameter group is used for configuring the closed loop PID Controller, that controls the output frequency of the frequency converter.

20-12 Reference/Feedback Unit

Option: **Function:**

[0] None

[1] * %

[5] PPM

[10] 1/min

[11] RPM

[12] Pulse/s

[20] l/s

[21] l/min

[22] l/h

[23] m³/s

[24] m³/min

[25] m³/h

[30] kg/s

[31] kg/min

[32] kg/h

[33] t/min

[34] t/h

[40] m/s

[41] m/min

[45] m

[60] °C

[70] mbar

[71] bar

[72] Pa

[73] kPa

[74] m WG

[75] mm Hg

[80] kW

[120] GPM

[121] gal/s

[122] gal/min

[123] gal/h

[124] CFM

[125] ft³/s

[126] ft³/min

[127] ft³/h

[130] lb/s

[131] lb/min

[132] lb/h

[140] ft/s

[141] ft/min

[145]	ft	
[160]	°F	
[170]	psi	
[171]	lb/in ²	
[172]	in WG	
[173]	ft WG	
[174]	in Hg	
[180]	HP	This parameter determines the unit that is used for the setpoint reference and feedback that the PID Controller will use for controlling the output frequency of the frequency converter.

20-21 Setpoint 1

Range:	Function:
0.000 Proc-essCtrlUnit* [-999999.999 - 999999.999 Proc-essCtrlUnit]	Setpoint 1 is used in Closed Loop Mode to enter a setpoint reference that is used by the frequency converter's PID Controller. See the description of par. 20-20 <i>Feedback Function</i> .
	 <p>NB! Setpoint reference entered here is added to any other references that are enabled (see par. group 3-1*).</p>

8

20-81 PID Normal/Inverse Control

Option:	Function:
[0] * Normal	
[1] Inverse	<i>Normal</i> [0] causes the frequency converter's output frequency to decrease when the feedback is greater than the setpoint reference. This is common for pressure-controlled supply fan and pump applications. <i>Inverse</i> [1] causes the frequency converter's output frequency to increase when the feedback is greater than the setpoint reference.

20-82 PID Start Speed [RPM]

Range:	Function:
Application dependent* [Application dependant]	

20-93 PID Proportional Gain

Range:	Function:
2.00* [0.00 - 10.00]	

If (Error x Gain) jumps with a value equal to what is set in par. 20-14 *Maximum Reference/Feedb*, the PID controller will try to change the output speed equal to what is set in par. 4-13 *Motor Speed High Limit [RPM]*/par. 4-14 *Motor Speed High Limit [Hz]* but in practice of course limited by this setting. The proportional band (error causing output to change from 0-100%) can be calculated by means of the formula:

$$\left(\frac{1}{\text{Proportional Gain}} \right) \times (\text{Max Reference})$$

<p>NB! Always set the desired for par. 20-14 <i>Maximum Reference/Feedb</i>, before setting the values for the PID controller in par. group 20-9*.</p>

20-94 PID Integral Time

Range:

8.00 s* [0.01 - 10000.00 s]

Function:

Over time, the integrator accumulates a contribution to the output from the PID controller as long as there is a deviation between the Reference/Setpoint and feedback signals. The contribution is proportional to the size of the deviation. This ensures that the deviation (error) approaches zero. Quick response on any deviation is obtained when the integral time is set to a low value. Setting it too low, however, may cause the control to become unstable.

The value set, is the time needed for the integrator to add the same contribution as the proportional part for a certain deviation.

If the value is set to 10,000, the controller will act as a pure proportional controller with a P-band based on the value set in par. 20-93 *PID Proportional Gain*. When no deviation is present, the output from the proportional controller will be 0.

8.2.10 22-** Miscellaneous

This group contains parameters used for monitoring water/ wastewater applications.

22-20 Low Power Auto Set-up

Option:

Function:

When set for *Enabled*, an auto set up sequence is activated, automatically setting speed to approx. 50 and 85% of rated motor speed (par. 4-13 *Motor Speed High Limit [RPM]*, par. 4-14 *Motor Speed High Limit [Hz]*). At those two speeds, the power consumption is automatically measured and stored.

Before enabling Auto Set Up:

1. Close valve(s) in order to create a no flow condition
2. The frequency converter must be set for Open Loop (par. 1-00 *Configuration Mode*).

Note that it is important also to set par. 1-03 *Torque Characteristics*.

[0] * Off

[1] Enabled



NB!

Auto Set Up must be done when the system has reached normal operating temperature!



NB!

It is important that the par. 4-13 *Motor Speed High Limit [RPM]* or par. 4-14 *Motor Speed High Limit [Hz]* is set to the max. operational speed of the motor!

It is important to do the Auto Set-up before configuring the integrated PI Controller as settings will be reset when changing from Closed to Open Loop in par. 1-00 *Configuration Mode*.



NB!

Carry out the tuning with the same settings in par. 1-03 *Torque Characteristics*, as for operation after the tuning.

22-21 Low Power Detection

Option:

Function:

[0] * Disabled

[1] Enabled

If selecting Enabled, the Low Power Detection commissioning must be carried out in order to set the parameters in group 22-3* for proper operation!

22-22 Low Speed Detection

Option:

Function:

[0] * Disabled

[1] Enabled

Select Enabled for detecting when the motor operates with a speed as set in par. 4-11 *Motor Speed Low Limit [RPM]* or par. 4-12 *Motor Speed Low Limit [Hz]*.

22-23 No-Flow Function

Option:

Function:

Common actions for Low Power Detection and Low Speed Detection (Individual selections not possible).

[0] * Off

[1] Sleep Mode

[2] Warning Messages in the Local Control Panel display (if mounted) and/or signal via a relay or a digital output.

[3] Alarm The frequency converter trips and motor stays stopped until reset.

22-24 No-Flow Delay

Range:

Function:

10 s* [1 - 600 s]

Set the time Low Power/Low Speed must stay detected to activate signal for actions. If detection disappears before run out of the timer, the timer will be reset.

22-26 Dry Pump Function

Option:

Function:

Low Power Detection must be Enabled (par. 22-21 *Low Power Detection*) and commissioned (using either parameter group 22-3*, *No Flow Power Tuning*, or par. 22-20 *Low Power Auto Set-up*) in order to use Dry Pump Detection.

[0] * Off

[1] Warning Messages in the Local Control Panel display (if mounted) and/or signal via a relay or a digital output.

[2] Alarm The frequency converter trips and motor stays stopped until reset.

[3] Manual Reset Alarm

22-27 Dry Pump Delay

Range:

Function:

10 s* [0 - 600 s]

Defines for how long the Dry Pump condition must be active before activating Warning or Alarm

22-30 No-Flow Power

Range:

Function:

0.00 kW* [0.00 - 0.00 kW]

Read out of calculated No Flow power at actual speed. If power drops to the display value the frequency converter will consider the condition as a No Flow situation.

22-31 Power Correction Factor

Range:

Function:

100 %* [1 - 400 %]

Make corrections to the calculated power at par. 22-30 *No-Flow Power*.
If No Flow is detected, when it should not be detected, the setting should be decreased. However, if No Flow is not detected, when it should be detected, the setting should be increased to above 100%.

22-32 Low Speed [RPM]

Range:

Function:

Application [Application dependant]
dependent*

To be used if par. 0-02 *Motor Speed Unit* has been set for RPM (parameter not visible if Hz selected).
Set used speed for the 50% level.
This function is used for storing values needed to tune No Flow Detection.

22-33 Low Speed [Hz]

Range:

Application [Application dependant]
dependent*

Function:

To be used if par. 0-02 *Motor Speed Unit* has been set for Hz (parameter not visible if RPM selected).
Set used speed for the 50% level.
The function is used for storing values needed to tune No Flow Detection.

22-34 Low Speed Power [kW]

Range:

Application [Application dependant]
dependent*

Function:

To be used if par. 0-03 *Regional Settings* has been set for International (parameter not visible if North America selected).
Set power consumption at 50% speed level.
This function is used for storing values needed to tune No Flow Detection.

22-35 Low Speed Power [HP]

Range:

Application [Application dependant]
dependent*

Function:

To be used if par. 0-03 *Regional Settings* has been set for North America (parameter not visible if International selected).
Set power consumption at 50% speed level.
This function is used for storing values needed to tune No Flow Detection.

22-36 High Speed [RPM]

Range:

Application [Application dependant]
dependent*

Function:

To be used if par. 0-02 *Motor Speed Unit* has been set for RPM (parameter not visible if Hz selected).
Set used speed for the 85% level.
The function is used for storing values needed to tune No Flow Detection.

22-37 High Speed [Hz]

Range:

Application [Application dependant]
dependent*

Function:

To be used if par. 0-02 *Motor Speed Unit* has been set for Hz (parameter not visible if RPM selected).
Set used speed for the 85% level.
The function is used for storing values needed to tune No Flow Detection.

22-38 High Speed Power [kW]

Range:

Application [Application dependant]
dependent*

Function:

To be used if par. 0-03 *Regional Settings* has been set for International (parameter not visible if North America selected).
Set power consumption at 85% speed level.
This function is used for storing values needed to tune No Flow Detection.

22-39 High Speed Power [HP]

Range:

Application [Application dependant]
dependent*

Function:

To be used if par. 0-03 *Regional Settings* has been set for North America (parameter not visible if International selected).
Set power consumption at 85% speed level.
This function is used for storing values needed to tune No Flow Detection.

22-40 Minimum Run Time

Range:

60 s* [0 - 600 s]

Function:

Set the desired minimum running time for the motor after a start command (digital input or Bus) before entering Sleep Mode.

22-41 Minimum Sleep Time

Range:

30 s* [0 - 600 s]

Function:

Set the desired Minimum Time for staying in Sleep Mode. This will override any wake up conditions.

22-42 Wake-up Speed [RPM]

Range:

Application [Application dependant]
dependent*

Function:

To be used if par. 0-02 *Motor Speed Unit* has been set for RPM (parameter not visible if Hz selected). Only to be used if par. 1-00 *Configuration Mode* is set for Open Loop and speed reference is applied by an external controller.
Set the reference speed at which the Sleep Mode should be cancelled.

22-43 Wake-up Speed [Hz]

Range:

Application [Application dependant]
dependent*

Function:

To be used if par. 0-02 *Motor Speed Unit*, has been set for Hz (parameter not visible if RPM selected). Only to be used if par. 1-00 *Configuration Mode*, is set for Open Loop and speed reference is applied by an external controller controlling the pressure.
Set the reference speed at which the Sleep Mode should be cancelled.

22-44 Wake-up Ref./FB Difference

Range:

10%* [0-100%]

Function:

Only to be used if par. 1-00, *Configuration Mode*, is set for Closed Loop and the integrated PI controller is used for controlling the pressure.
Set the pressure drop allowed in percentage of set point for the pressure (Pset) before cancelling the Sleep Mode.



NB!

If used in application where the integrated PI controller is set for inverse control in par. 20-71, *PID, Normal/Inverse Control*, the value set in par. 22-44 will automatically be added.

22-45 Setpoint Boost

Range:

0 %* [-100 - 100 %]

Function:

Only to be used if par. 1-00 *Configuration Mode*, is set for Closed Loop and the integrated PI controller is used. In systems with e.g. constant pressure control, it is advantageous to increase the system pressure before the motor is stopped. This will extend the time in which the motor is stopped and help to avoid frequent start/stop.
Set the desired over pressure/temperature in percentage of set point for the pressure (Pset)/temperature before entering the Sleep Mode.
If setting for 5%, the boost pressure will be Pset*1.05. The negative values can be used for e.g. cooling tower control where a negative change is needed.

22-46 Maximum Boost Time

Range:

60 s* [0 - 600 s]

Function:

Only to be used if par. 1-00 *Configuration Mode* is set for Closed Loop and the integrated PI controller is used for controlling the pressure.
Set the maximum time for which boost mode will be allowed. If the set time is exceeded, Sleep Mode will be entered, not waiting for the set boost pressure to be reached.

22-50 End of Curve Function

Option:	Function:
[0] * Off	End of Curve monitoring not active.
[1] Warning	A warning is issued in the display [W94].
[2] Alarm	An alarm is issued and the frequency converter trips. A message [A94] appears in the display.
[3] Manual Reset Alarm	



NB!
Automatic restart will reset the alarm and start the system again.

22-51 End of Curve Delay

Range:	Function:
10 s* [0 - 600 s]	When an End of Curve condition is detected, a timer is activated. When the time set in this parameter expires, and the End of Curve condition has been steady in the entire period, the function set in par. 22-50 <i>End of Curve Function</i> will be activated. If the condition disappears before the timer expires, the timer will be reset.

22-80 Flow Compensation

Option:	Function:
[0] * Disabled	[0] <i>Disabled</i> : Set-Point compensation not active.
[1] Enabled	[1] <i>Enabled</i> : Set-Point compensation is active. Enabling this parameter allows the Flow Compensated Setpoint operation.

22-81 Square-linear Curve Approximation

Range:	Function:
100 %* [0 - 100 %]	<p>Example 1: Adjustment of this parameter allows the shape of the control curve to be adjusted.</p> <p>0 = Linear 100% = Ideal shape (theoretical).</p>



NB!
Please note: Not visible when running in cascade.

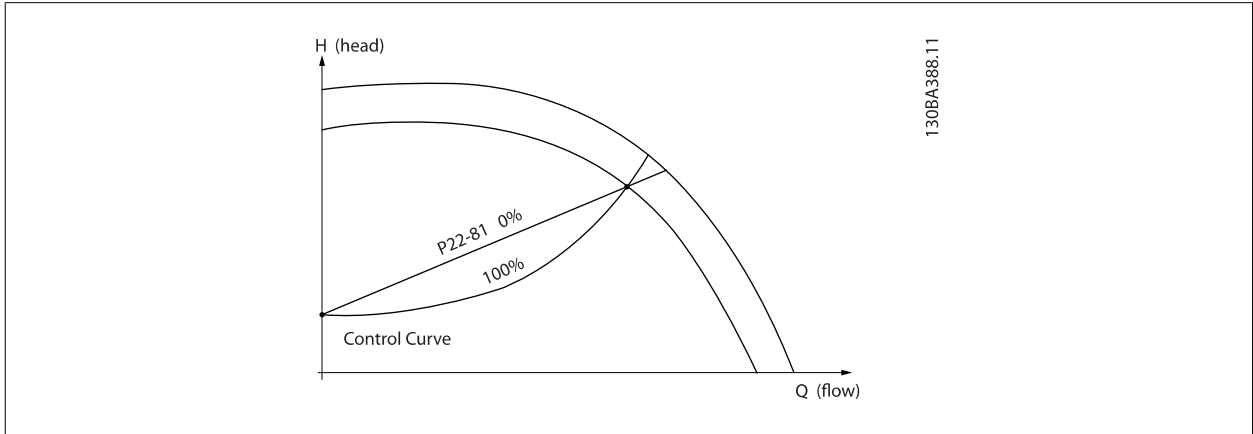

22-82 Work Point Calculation

Option:

Function:

Example 1: Speed at System Design Working Point is known:

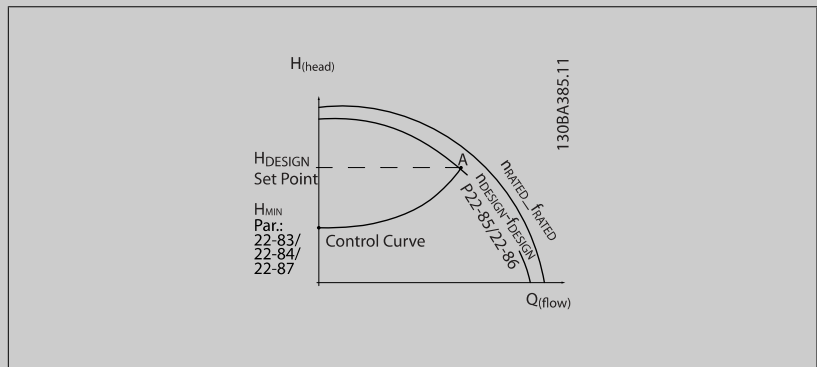

From the data sheet showing characteristics for the specific equipment at different speeds, simply reading across from the H_{DESIGN} point and the Q_{DESIGN} point allows us to find point A, which is the System Design Working Point. The pump characteristics at this point should be identified and the associated speed programmed. Closing the valves and adjusting the speed until H_{MIN} has been achieved allows the speed at the no flow point to be identified.

Adjustment of par. 22-81 *Square-linear Curve Approximation* then allows the shape of the control curve to be adjusted infinitely.

Example 2:

Speed at System Design Working Point is not known: Where the Speed at System Design Working Point is unknown, another reference point on the control curve needs to be determined by means of the data sheet. By looking at the curve for the rated speed and plotting the design pressure (H_{DESIGN} , Point C) the flow at that pressure Q_{RATED} can be determined. Similarly, by plotting the design flow (Q_{DESIGN} , Point D), the pressure H_D at that flow can be determined. Knowing these two points on the pump curve, along with H_{MIN} as described above, allows the frequency converter to calculate the reference point B and thus to plot the control curve which will also include the System design Working Point A.

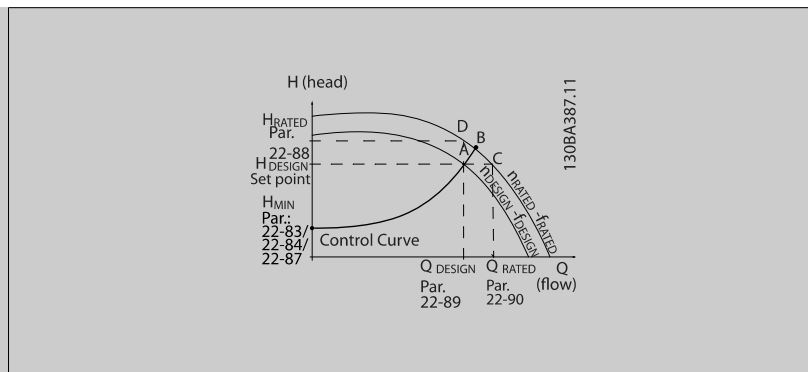

[0] * Disabled *Disabled [0]:* Work Point Calculation not active. To be used if speed at design point is known (see table above).

[1] Enabled *Enabled [1]:* Work Point Calculation is active. Enabling this parameter allows the calculation of the unknown System Design Working Point at 50/60 Hz speed, from the input data set in par. 22-83 *Speed at No-Flow [RPM]* par. 22-84 *Speed at No-Flow [Hz]*, par. 22-87 *Pressure at No-Flow Speed*, par. 22-88 *Pressure at Rated Speed*, par. 22-89 *Flow at Design Point* and par. 22-90 *Flow at Rated Speed*.

22-83 Speed at No-Flow [RPM]

Range:

Application [Application dependant] dependent*

Function:

Resolution 1 RPM.
The speed of the motor at which flow is zero and minimum pressure H_{MIN} is achieved should be entered here in RPM. Alternatively, the speed in Hz can be entered in par. 22-84 *Speed at No-Flow [Hz]*. If it has been decided to use RPM in par. 0-02 *Motor Speed Unit* then par. 22-85 *Speed at Design Point [RPM]* should also be used. Closing the valves and reducing the speed until minimum pressure H_{MIN} is achieved will determine this value.

22-84 Speed at No-Flow [Hz]

Range:

Application [Application dependant] dependent*

Function:

Resolution 0.033 Hz.
The speed of the motor at which flow has effectively stopped and minimum pressure H_{MIN} is achieved should be entered here in Hz. Alternatively, the speed in RPM can be entered in par. 22-83 *Speed at No-Flow [RPM]*. If it has been decided to use Hz in par. 0-02 *Motor Speed Unit* then par. 22-86 *Speed at Design Point [Hz]* should also be used. Closing the valves and reducing the speed until minimum pressure H_{MIN} is achieved will determine this value.

22-85 Speed at Design Point [RPM]

Range:

Application [Application dependant] dependent*

Function:

Resolution 1 RPM.
Only visible when par. 22-82 *Work Point Calculation* is set to *Disable*. The speed of the motor at which the System Design Working Point is achieved should be entered here in RPM. Alternatively, the speed in Hz can be entered in par. 22-86 *Speed at Design Point [Hz]*. If it has been decided to use RPM in par. 0-02 *Motor Speed Unit* then par. 22-83 *Speed at No-Flow [RPM]* should also be used.

22-86 Speed at Design Point [Hz]

Range:

Application [Application dependant]
 dependent*

Function:

Resolution 0.033 Hz.
 Only visible when par. 22-82 *Work Point Calculation* is set to *Disable*. The speed of the motor at which the System Design Working Point is achieved should be entered here in Hz. Alternatively, the speed in RPM can be entered in par. 22-85 *Speed at Design Point [RPM]*. If it has been decided to use Hz in par. 0-02 *Motor Speed Unit*, then par. 22-83 *Speed at No-Flow [RPM]* should also be used.

22-87 Pressure at No-Flow Speed

Range:

0.000* [Application dependant]

Function:

Enter the pressure H_{MIN} corresponding to Speed at No Flow in Reference/Feedback Units.

22-88 Pressure at Rated Speed

Range:

999999.999 [Application dependant]
 *

Function:

Enter the value corresponding to the Pressure at Rated Speed, in Reference/Feedback Units. This value can be defined using the pump datasheet.

22-90 Flow at Rated Speed

Range:

0.000* [0.000 - 999999.999]

Function:

Enter the value corresponding to Flow at Rated Speed. This value can be defined using the pump datasheet.

8.2.11 23-0* Timed Actions

Use *Timed Actions* for actions needing to be performed on a daily or weekly basis, e.g. different references for working hours / non-working hours. Up to 10 Timed Actions can be programmed in the frequency converter. The Timed Action number is selected from the list when entering parameter group 23-0* from the . par. 23-00 *ON Time* – par. 23-04 *Occurrence* then refer to the selected Timed Action number. Each Timed Action is divided into an ON time and an OFF time, in which two different actions may be performed.

The actions programmed in Timed Actions are merged with corresponding actions from digital inputs, control work via bus and Smart Logic Controller, according to merge rules set up in 8-5*, Digital/Bus.



NB!

The clock (parameter group 0-7*) must be correctly programmed for Timed Actions to function correctly.



NB!

When mounting an Analog I/O MCB109 option card, a battery back up of the date and time is included.

NB!

The PC-based Configuration Tool MCT 10 comprise a special guide for easy programming of Timed Actions.

8

23-00 ON Time

Array [10]

Range:

Application [Application dependant]
dependent*

Function:

Sets the ON time for the Timed Action.



NB!

The frequency converter has no back up of the clock function and the set date/ time will reset to default (2000-01-01 00:00) after a power down unless a Real Time Clock module with back up is installed. In par. 0-79 *Clock Fault* it is possible to program for a Warning in case clock has not been set properly, e.g. after a power down.

23-01 ON Action

Arra [10]

Option:

Function:

Select the action during ON Time. See par. 13-52 *SL Controller Action* for descriptions of the options.

[0] * Disabled

[1] No action

[2] Select set-up 1

[3] Select set-up 2

[4] Select set-up 3

[5] Select set-up 4

[10] Select preset ref 0

[11] Select preset ref 1

[12] Select preset ref 2

[13] Select preset ref 3

[14] Select preset ref 4

[15] Select preset ref 5

[16] Select preset ref 6

[17] Select preset ref 7

[18] Select ramp 1

[19] Select ramp 2

[22] Run

[23] Run reverse

[24] Stop

[26] DC Brake

[27] Coast

[28] Freeze output

[29] Start timer 0

[30] Start timer 1

[31] Start timer 2

[32] Set digital out A low

[33] Set digital out B low

[34] Set digital out C low

[35] Set digital out D low

[36] Set digital out E low

[37] Set digital out F low

[38] Set digital out A high

[39] Set digital out B high

[40] Set digital out C high

[41] Set digital out D high

[42] Set digital out E high

[43] Set digital out F high

[60] Reset Counter A

[61] Reset Counter B

[70] Start Timer 3

[71] Start Timer 4

[72] Start Timer 5

[73] Start Timer 6

[74] Start Timer 7

NB!

For choices [32] - [43], see also par. group 5-3*, *Digital Outputs* and 5-4*, *Relays*.

23-02 OFF Time

Array [10]

Range:

Application [Application dependant]
dependent*

Function:

Sets the OFF time for the Timed Action.



NB!

The frequency converter has no back up of the clock function and the set date/time will reset to default (2000-01-01 00:00) after a power down unless a Real Time Clock module with back up is installed. In par. 0-79 *Clock Fault* it is possible to program for a Warning in case clock has not been set properly, e.g. after a power down.

23-03 OFF Action

Array [10]

Option:

Function:

Select the action during OFF Time. See par. 13-52 *SL Controller Action* for descriptions of the options.

[0] * Disabled

[1] * No action

[2] Select set-up 1

[3] Select set-up 2

[4] Select set-up 3

[5] Select set-up 4

[10] Select preset ref 0

[11] Select preset ref 1

[12] Select preset ref 2

[13] Select preset ref 3

[14] Select preset ref 4

[15] Select preset ref 5

[16] Select preset ref 6

[17] Select preset ref 7

[18] Select ramp 1

[19] Select ramp 2

[22] Run

[23] Run reverse

[24] Stop

[26] DC Brake

[27] Coast

[28] Freeze output

[29] Start timer 0

[30] Start timer 1

[31] Start timer 2

[32] Set digital out A low

[33] Set digital out B low

[34] Set digital out C low

- [35] Set digital out D low
- [36] Set digital out E low
- [37] Set digital out F low
- [38] Set digital out A high
- [39] Set digital out B high
- [40] Set digital out C high
- [41] Set digital out D high
- [42] Set digital out E high
- [43] Set digital out F high
- [60] Reset Counter A
- [61] Reset Counter B
- [70] Start Timer 3
- [71] Start Timer 4
- [72] Start Timer 5
- [73] Start Timer 6
- [74] Start Timer 7

23-04 Occurrence

Array [10]

Option:

Function:

Select which day(s) the Timed Action applies to. Specify working/non-working days in par. 0-81 *Working Days*, par. 0-82 *Additional Working Days* and par. 0-83 *Additional Non-Working Days*.

- [0] * All days
- [1] Working days
- [2] Non-working days
- [3] Monday
- [4] Tuesday
- [5] Wednesday
- [6] Thursday
- [7] Friday
- [8] Saturday
- [9] Sunday

8.2.12 Water Application Functions, 29-**

The group contains parameters used for monitoring water / wastewater applications.

29-00 Pipe Fill Enable

Option:

Function:

- [0] * Disabled Select Enabled to fill pipes at a user specified rate.
- [1] Enabled Select Enabled to fill pipes with a user specified rate.

29-01 Pipe Fill Speed [RPM]

Range:

Speed Low [Speed Low Limit - Speed High Limit* it]

Function:

Set the filling speed for filling horizontal pipe systems. The speed can be selected in Hz or RPM depending on the choices made in par. 4-11 / par. 4-13 (RPM) or in par. 4-12 / par. 4-14 (Hz).

29-02 Pipe Fill Speed [Hz]

Range:

Motor [Speed Low Limit - Speed High Limit* it]
Speed Low it]
Limit*

Function:

Set the filling speed for filling horizontal pipe systems. The speed can be selected in Hz or RPM depending on the choices made in par. 4-11 / par. 4-13 (RPM) or in par. 4-12 / par. 4-14 (Hz).

29-03 Pipe Fill Time

Range:

0 s* [0 - 3600 s]

Function:

Set the specified time for pipe filling of horizontal pipe systems.

29-04 Pipe Fill Rate

Range:

0.001 units/ s* [0.001 – 999999.999 units/s]

Function:

Specifies the filling rate in units/second using the PI controller. Filling rate units are feedback units/second. This function is used for filling-up vertical pipe systems but will be active when the filling-time has expired, no matter what , until the pipe fill-set-point set in par. 29-05 is reached.

29-05 Filled Setpoint

Range:

0 s* [0 – 999999,999 s]

Function:

Specifies the Filled Set-point at which the Pipe Fill Function will be disabled and the PID controller will take control. This function can be used both for horizontal and vertical pipe systems.

8.3 Parameter Options

8.3.1 Default Settings

Changes during operation:

"TRUE" means that the parameter can be changed while the frequency converter is in operation and "FALSE" means that the frequency converter must be stopped before a change can be made.

4-Set-up:

'All set-up': the parameter can be set individually in each of the four set-ups, i. e. one single parameter can have four different data values.

'1 set-up': data value will be the same in all set-ups.

SR:

Size related

N/A:

No default value available.

Conversion index:

This number refers to a conversion figure used when writing or reading by means of a frequency converter.

Conv. index	100	67	6	5	4	3	2	1	0	-1	-2	-3	-4	-5	-6
Conv. factor	1	1/60	1000000	100000	10000	1000	100	10	1	0.1	0.01	0.001	0.0001	0.00001	0.000001

Data type	Description	Type
2	Integer 8	Int8
3	Integer 16	Int16
4	Integer 32	Int32
5	Unsigned 8	UInt8
6	Unsigned 16	UInt16
7	Unsigned 32	UInt32
9	Visible String	VisStr
33	Normalized value 2 bytes	N2
35	Bit sequence of 16 boolean variables	V2
54	Time difference w/o date	TimD



8.3.2 Operation/Display 0--**

Par. No. #	Parameter description	Default value	4-set-up	Change during operation	Conversion Index	Type
0-0* Basic Settings						
0-01	Language	[0] English	1 set-up	TRUE	-	Uint8
0-02	Motor Speed Unit	[0] RPM	2 set-ups	FALSE	-	Uint8
0-03	Regional Settings	[0] International	2 set-ups	FALSE	-	Uint8
0-04	Operating State at Power-up	[0] Resume	All set-ups	TRUE	-	Uint8
0-05	Local Mode Unit	[0] As Motor Speed Unit	2 set-ups	FALSE	-	Uint8
0-1* Set-up Operations						
0-10	Active Set-up	[1] Set-up 1	1 set-up	TRUE	-	Uint8
0-11	Programming Set-up	[9] Active Set-up	All set-ups	TRUE	-	Uint8
0-12	This Set-up Linked to	[0] Not linked	All set-ups	FALSE	-	Uint8
0-13	Readout: Linked Set-ups	0 N/A	All set-ups	FALSE	0	Uint16
0-14	Readout: Prog. Set-ups / Channel	0 N/A	All set-ups	TRUE	0	Int32
0-2* LCP Display						
0-20	Display Line 1.1 Small	1601	All set-ups	TRUE	-	Uint16
0-21	Display Line 1.2 Small	1662	All set-ups	TRUE	-	Uint16
0-22	Display Line 1.3 Small	1614	All set-ups	TRUE	-	Uint16
0-23	Display Line 2 Large	1613	All set-ups	TRUE	-	Uint16
0-24	Display Line 3 Large	1652	All set-ups	TRUE	-	Uint16
0-25	My Personal Menu	SR	1 set-up	TRUE	0	Uint16
0-3* LCP Custom Readout						
0-30	Custom Readout Unit	[1] %	All set-ups	TRUE	-	Uint8
0-31	Custom Readout Min Value	SR	All set-ups	TRUE	-2	Int32
0-32	Custom Readout Max Value	100.00 CustomReadoutUnit	All set-ups	TRUE	-2	Int32
0-37	Display Text 1	0 N/A	1 set-up	TRUE	0	VisStr[25]
0-38	Display Text 2	0 N/A	1 set-up	TRUE	0	VisStr[25]
0-39	Display Text 3	0 N/A	1 set-up	TRUE	0	VisStr[25]
0-4* LCP Keypad						
0-40	[Hand on] Key on LCP	[1] Enabled	All set-ups	TRUE	-	Uint8
0-41	[Off] Key on LCP	[1] Enabled	All set-ups	TRUE	-	Uint8
0-42	[Auto on] Key on LCP	[1] Enabled	All set-ups	TRUE	-	Uint8
0-43	[Reset] Key on LCP	[1] Enabled	All set-ups	TRUE	-	Uint8
0-44	[Off/Reset] Key on LCP	[1] Enabled	All set-ups	TRUE	-	Uint8
0-45	[Drive Bypass] Key on LCP	[1] Enabled	All set-ups	TRUE	-	Uint8
0-5* Copy/Save						
0-50	LCP Copy	[0] No copy	All set-ups	FALSE	-	Uint8
0-51	Set-up Copy	[0] No copy	All set-ups	FALSE	-	Uint8

Par. No. #	Parameter description	Default value	4-set-up	Change during operation	Conversion index	Type
0-6* Password						
0-60	Main Menu Password	100 N/A	1 set-up	TRUE	0	Uint16
0-61	Access to Main Menu w/o Password	[0] Full access	1 set-up	TRUE	-	Uint8
0-65	Personal Menu Password	200 N/A	1 set-up	TRUE	0	Uint16
0-66	Access to Personal Menu w/o Password	[0] Full access	1 set-up	TRUE	-	Uint8
0-7* Clock Settings						
0-70	Date and Time	SR	All set-ups	TRUE	0	TimeOfDay
0-71	Date Format	[0] YYYY-MM-DD	1 set-up	TRUE	-	Uint8
0-72	Time Format	[0] 24 h	1 set-up	TRUE	-	Uint8
0-74	DST/Summertime	[0] Off	1 set-up	TRUE	-	Uint8
0-76	DST/Summertime Start	SR	1 set-up	TRUE	0	TimeOfDay
0-77	DST/Summertime End	SR	1 set-up	TRUE	0	TimeOfDay
0-79	Clock Fault	null	1 set-up	TRUE	-	Uint8
0-81	Working Days	null	1 set-up	TRUE	-	Uint8
0-82	Additional Working Days	SR	1 set-up	TRUE	0	TimeOfDay
0-83	Additional Non-Working Days	SR	1 set-up	TRUE	0	TimeOfDay
0-89	Date and Time Readout	0 N/A	All set-ups	TRUE	0	VisStr[25]

8.3.3 Load/Motor 1-.*

Par. No. #	Parameter description	Default value	4-set-up	Change during operation	Conversion Index	Type
1-0* General Settings						
1-00	Configuration Mode	null	All set-ups	TRUE	-	Uint8
1-01	Motor Control Principle	null	All set-ups	FALSE	-	Uint8
1-03	Torque Characteristics	[3] Auto Energy Optim. VT	All set-ups	TRUE	-	Uint8
1-1* Motor Selection						
1-10	Motor Construction	[0] Asynchron	All set-ups	FALSE	-	Uint8
1-2* Motor Data						
1-20	Motor Power [kW]	SR	All set-ups	FALSE	1	Uint32
1-21	Motor Power [HP]	SR	All set-ups	FALSE	-2	Uint32
1-22	Motor Voltage	SR	All set-ups	FALSE	0	Uint16
1-23	Motor Frequency	SR	All set-ups	FALSE	0	Uint16
1-24	Motor Current	SR	All set-ups	FALSE	-2	Uint32
1-25	Motor Nominal Speed	SR	All set-ups	FALSE	67	Uint16
1-28	Motor Rotation Check	[0] Off	All set-ups	FALSE	-	Uint8
1-29	Automatic Motor Adaptation (AMA)	[0] Off	All set-ups	FALSE	-	Uint8
1-3* Adv. Motor Data						
1-30	Stator Resistance (Rs)	SR	All set-ups	FALSE	-4	Uint32
1-31	Rotor Resistance (Rr)	SR	All set-ups	FALSE	-4	Uint32
1-32	Stator Reactance (Xs)	SR	All set-ups	FALSE	-4	Uint32
1-33	Stator Leakage Reactance (X1)	SR	All set-ups	FALSE	-4	Uint32
1-34	Rotor Leakage Reactance (X2)	SR	All set-ups	FALSE	-4	Uint32
1-35	Main Reactance (Xh)	SR	All set-ups	FALSE	-4	Uint32
1-36	Iron Loss Resistance (Rfe)	SR	All set-ups	FALSE	-3	Uint32
1-39	Motor Poles	SR	All set-ups	FALSE	0	Uint8
1-5* Load Indep. Setting						
1-50	Motor Magnetisation at Zero Speed	100 %	All set-ups	TRUE	0	Uint16
1-51	Min Speed Normal Magnetising [RPM]	SR	All set-ups	TRUE	67	Uint16
1-52	Min Speed Normal Magnetising [Hz]	SR	All set-ups	TRUE	-1	Uint16
1-55	V/f Characteristic - v	SR	All set-ups	TRUE	-1	Uint16
1-56	V/f Characteristic - f	SR	All set-ups	TRUE	-1	Uint16
1-6* Load Depen. Setting						
1-60	Low Speed Load Compensation	100 %	All set-ups	TRUE	0	Int16
1-61	High Speed Load Compensation	100 %	All set-ups	TRUE	0	Int16
1-62	Slip Compensation	0 %	All set-ups	TRUE	0	Int16
1-63	Slip Compensation Time Constant	SR	All set-ups	TRUE	-2	Uint16
1-64	Resonance Dampening	100 %	All set-ups	TRUE	0	Uint16
1-65	Resonance Dampening Time Constant	5 ms	All set-ups	TRUE	-3	Uint8
1-7* Start Adjustments						
1-71	Start Delay	0.0 s	All set-ups	TRUE	-1	Uint16
1-73	Flying Start	[0] Disabled	All set-ups	FALSE	-	Uint8
1-74	Start Speed [RPM]	SR	All set-ups	TRUE	67	Uint16
1-75	Start Speed [Hz]	SR	All set-ups	TRUE	-1	Uint16
1-76	Start Current	0.00 A	All set-ups	TRUE	-2	Uint32

Par. No. #	Parameter description	Default value	4-set-up	Change during operation	Conversion index	Type
1-8* Stop Adjustments						
1-80	Function at Stop	[0] Coast	All set-ups	TRUE	-	Uint8
1-81	Min Speed for Function at Stop [RPM]	SR	All set-ups	TRUE	67	Uint16
1-82	Min Speed for Function at Stop [Hz]	SR	All set-ups	TRUE	-1	Uint16
1-86	Trip Speed Low [RPM]	0 RPM	All set-ups	TRUE	67	Uint16
1-87	Trip Speed Low [Hz]	0 Hz	All set-ups	TRUE	-1	Uint16
1-9* Motor Temperature						
1-90	Motor Thermal Protection	[4] ETR trip 1	All set-ups	TRUE	-	Uint8
1-91	Motor External Fan	[0] No	All set-ups	TRUE	-	Uint16
1-93	Thermistor Source	[0] None	All set-ups	TRUE	-	Uint8

8.3.4 Brakes 2-**

Par. No. #	Parameter description	Default value	4-set-up	Change during operation	Conversion index	Type
2-0* DC-Brake						
2-00	DC Hold/Preheat Current	50 %	All set-ups	TRUE	0	Uint8
2-01	DC Brake Current	50 %	All set-ups	TRUE	0	Uint16
2-02	DC Braking Time	10.0 s	All set-ups	TRUE	-1	Uint16
2-03	DC Brake Cut In Speed [RPM]	SR	All set-ups	TRUE	67	Uint16
2-04	DC Brake Cut In Speed [Hz]	SR	All set-ups	TRUE	-1	Uint16
2-1* Brake Energy Funct.						
2-10	Brake Function	[0] Off	All set-ups	TRUE	-	Uint8
2-11	Brake Resistor (ohm)	SR	All set-ups	TRUE	0	Uint16
2-12	Brake Power Limit (kW)	SR	All set-ups	TRUE	0	Uint32
2-13	Brake Power Monitoring	[0] Off	All set-ups	TRUE	-	Uint8
2-15	Brake Check	[0] Off	All set-ups	TRUE	-	Uint8
2-16	AC brake Max. Current	100.0 %	All set-ups	TRUE	-1	Uint32
2-17	Over-voltage Control	[2] Enabled	All set-ups	TRUE	-	Uint8

8.3.5 Reference / Ramps 3-**-**

Par. No. #	Parameter description	Default value	4-set-up	Change during operation	Conversion Index	Type
3-0* Reference Limits						
3-02	Minimum Reference	SR	All set-ups	TRUE	-3	Int32
3-03	Maximum Reference	SR	All set-ups	TRUE	-3	Int32
3-04	Reference Function	[0] Sum	All set-ups	TRUE	-	UInt8
3-1* References						
3-10	Preset Reference	0.00 %	All set-ups	TRUE	-2	Int16
3-11	Jog Speed [Hz]	SR	All set-ups	TRUE	-1	UInt16
3-13	Reference Site	[0] Linked to Hand / Auto	All set-ups	TRUE	-	UInt8
3-14	Preset Relative Reference	0.00 %	All set-ups	TRUE	-2	Int32
3-15	Reference 1 Source	[1] Analog input 53	All set-ups	TRUE	-	UInt8
3-16	Reference 2 Source	[0] No function	All set-ups	TRUE	-	UInt8
3-17	Reference 3 Source	[0] No function	All set-ups	TRUE	-	UInt8
3-19	Jog Speed [RPM]	SR	All set-ups	TRUE	67	UInt16
3-4* Ramp 1						
3-41	Ramp 1 Ramp Up Time	SR	All set-ups	TRUE	-2	UInt32
3-42	Ramp 1 Ramp Down Time	SR	All set-ups	TRUE	-2	UInt32
3-5* Ramp 2						
3-51	Ramp 2 Ramp Up Time	SR	All set-ups	TRUE	-2	UInt32
3-52	Ramp 2 Ramp Down Time	SR	All set-ups	TRUE	-2	UInt32
3-8* Other Ramps						
3-80	Jog Ramp Time	SR	All set-ups	TRUE	-2	UInt32
3-81	Quick Stop Ramp Time	SR	2 set-ups	TRUE	-2	UInt32
3-84	Initial Ramp Time	0.00 s	All set-ups	TRUE	-2	UInt16
3-85	Check Valve Ramp Time	0.00 s	All set-ups	TRUE	-2	UInt16
3-86	Check Valve Ramp End Speed [RPM]	SR	All set-ups	TRUE	67	UInt16
3-87	Check Valve Ramp End Speed [Hz]	SR	All set-ups	TRUE	-1	UInt16
3-88	Final Ramp Time	0.00 s	All set-ups	TRUE	-2	UInt16
3-9* Digital Pot. Meter						
3-90	Step Size	0.10 %	All set-ups	TRUE	-2	UInt16
3-91	Ramp Time	1.00 s	All set-ups	TRUE	-2	UInt32
3-92	Power Restore	[0] Off	All set-ups	TRUE	-	UInt8
3-93	Maximum Limit	100 %	All set-ups	TRUE	0	Int16
3-94	Minimum Limit	0 %	All set-ups	TRUE	0	Int16
3-95	Ramp Delay	SR	All set-ups	TRUE	-3	TimD

8.3.6 Limits / Warnings 4-**

Par. No. #	Parameter description	Default value	4-set-up	Change during operation	Conversion Index	Type
4-1* Motor Limits						
4-10	Motor Speed Direction	[0] Clockwise	All set-ups	FALSE	-	Uint8
4-11	Motor Speed Low Limit [RPM]	SR	All set-ups	TRUE	67	Uint16
4-12	Motor Speed Low Limit [Hz]	SR	All set-ups	TRUE	-1	Uint16
4-13	Motor Speed High Limit [RPM]	SR	All set-ups	TRUE	67	Uint16
4-14	Motor Speed High Limit [Hz]	SR	All set-ups	TRUE	-1	Uint16
4-16	Torque Limit Motor Mode	SR	All set-ups	TRUE	-1	Uint16
4-17	Torque Limit Generator Mode	100.0 %	All set-ups	TRUE	-1	Uint16
4-18	Current Limit	SR	All set-ups	TRUE	-1	Uint32
4-19	Max Output Frequency	SR	All set-ups	FALSE	-1	Uint16
4-5* Adj. Warnings						
4-50	Warning Current Low	0.00 A	All set-ups	TRUE	-2	Uint32
4-51	Warning Current High	ImaxVLT (P1637)	All set-ups	TRUE	-2	Uint32
4-52	Warning Speed Low	0 RPM	All set-ups	TRUE	67	Uint16
4-53	Warning Speed High	outputSpeedHighLimit (P413)	All set-ups	TRUE	67	Uint16
4-54	Warning Reference Low	-999999,999 N/A	All set-ups	TRUE	-3	Int32
4-55	Warning Reference High	999999,999 N/A	All set-ups	TRUE	-3	Int32
4-56	Warning Feedback Low	-999999,999 ReferenceFeedbackUnit	All set-ups	TRUE	-3	Int32
4-57	Warning Feedback High	999999,999 ReferenceFeedbackUnit	All set-ups	TRUE	-3	Int32
4-58	Missing Motor Phase Function	[2] Trip 10000 ms	All set-ups	TRUE	-	Uint8
4-6* Speed Bypass						
4-60	Bypass Speed From [RPM]	SR	All set-ups	TRUE	67	Uint16
4-61	Bypass Speed From [Hz]	SR	All set-ups	TRUE	-1	Uint16
4-62	Bypass Speed To [RPM]	SR	All set-ups	TRUE	67	Uint16
4-63	Bypass Speed To [Hz]	SR	All set-ups	TRUE	-1	Uint16
4-64	Semi-Auto Bypass Set-up	[0] Off	All set-ups	FALSE	-	Uint8

8.3.7 Digital In/Out 5-**-**

Par. No. #	Parameter description	Default value	4-set-up	Change during operation	Conversion Index	Type
5-0* Digital I/O mode						
5-00	Digital I/O Mode	[0] PNP - Active at 24V	All set-ups	FALSE	-	Uint8
5-01	Terminal 27 Mode	[0] Input	All set-ups	TRUE	-	Uint8
5-02	Terminal 29 Mode	[0] Input	All set-ups	TRUE	-	Uint8
5-1* Digital Inputs						
5-10	Terminal 18 Digital Input	[8] Start	All set-ups	TRUE	-	Uint8
5-11	Terminal 19 Digital Input	[0] No operation	All set-ups	TRUE	-	Uint8
5-12	Terminal 27 Digital Input	null	All set-ups	TRUE	-	Uint8
5-13	Terminal 29 Digital Input	[0] No operation	All set-ups	TRUE	-	Uint8
5-14	Terminal 32 Digital Input	[0] No operation	All set-ups	TRUE	-	Uint8
5-15	Terminal 33 Digital Input	[0] No operation	All set-ups	TRUE	-	Uint8
5-16	Terminal X30/2 Digital Input	[0] No operation	All set-ups	TRUE	-	Uint8
5-17	Terminal X30/3 Digital Input	[0] No operation	All set-ups	TRUE	-	Uint8
5-18	Terminal X30/4 Digital Input	[0] No operation	All set-ups	TRUE	-	Uint8
5-3* Digital Outputs						
5-30	Terminal 27 Digital Output	[0] No operation	All set-ups	TRUE	-	Uint8
5-31	Terminal 29 Digital Output	[0] No operation	All set-ups	TRUE	-	Uint8
5-32	Term X30/6 Digi Out (MCB 101)	[0] No operation	All set-ups	TRUE	-	Uint8
5-33	Term X30/7 Digi Out (MCB 101)	[0] No operation	All set-ups	TRUE	-	Uint8
5-4* Relays						
5-40	Function Relay	null	All set-ups	TRUE	-	Uint8
5-41	On Delay, Relay	0.01 s	All set-ups	TRUE	-2	Uint16
5-42	Off Delay, Relay	0.01 s	All set-ups	TRUE	-2	Uint16
5-5* Pulse Input						
5-50	Term. 29 Low Frequency	100 Hz	All set-ups	TRUE	0	Uint32
5-51	Term. 29 High Frequency	100 Hz	All set-ups	TRUE	0	Uint32
5-52	Term. 29 Low Ref./Feedb. Value	0.000 N/A	All set-ups	TRUE	-3	Int32
5-53	Term. 29 High Ref./Feedb. Value	100.000 N/A	All set-ups	TRUE	-3	Int32
5-54	Pulse Filter Time Constant #29	100 ms	All set-ups	FALSE	-3	Uint16
5-55	Term. 33 Low Frequency	100 Hz	All set-ups	TRUE	0	Uint32
5-56	Term. 33 High Frequency	100 Hz	All set-ups	TRUE	0	Uint32
5-57	Term. 33 Low Ref./Feedb. Value	0.000 N/A	All set-ups	TRUE	-3	Int32
5-58	Term. 33 High Ref./Feedb. Value	100.000 N/A	All set-ups	TRUE	-3	Int32
5-59	Pulse Filter Time Constant #33	100 ms	All set-ups	FALSE	-3	Uint16
5-6* Pulse Output						
5-60	Terminal 27 Pulse Output Variable	[0] No operation	All set-ups	TRUE	-	Uint8
5-62	Pulse Output Max Freq #27	5000 Hz	All set-ups	TRUE	0	Uint32
5-63	Terminal 29 Pulse Output Variable	[0] No operation	All set-ups	TRUE	-	Uint8
5-65	Pulse Output Max Freq #29	5000 Hz	All set-ups	TRUE	0	Uint32
5-66	Terminal X30/6 Pulse Output Variable	[0] No operation	All set-ups	TRUE	-	Uint8
5-68	Pulse Output Max Freq #X30/6	5000 Hz	All set-ups	TRUE	0	Uint32
5-9* Bus Controlled						
5-90	Digital & Relay Bus Control	0 N/A	All set-ups	TRUE	0	Uint32
5-93	Pulse Out #27 Bus Control	0.00 %	All set-ups	TRUE	-2	N2
5-94	Pulse Out #27 Timeout Preset	1.00 %	1 set-up	TRUE	-2	Uint16
5-95	Pulse Out #29 Bus Control	0.00 %	All set-ups	TRUE	-2	N2
5-96	Pulse Out #29 Timeout Preset	0.00 %	1 set-up	TRUE	-2	Uint16
5-97	Pulse Out #X30/6 Bus Control	0.00 %	All set-ups	TRUE	-2	N2
5-98	Pulse Out #X30/6 Timeout Preset	0.00 %	1 set-up	TRUE	-2	Uint16



8.3.8 Analog In/Out 6-**

Par. No. #	Parameter description	Default value	4-set-up	Change during operation	Conversion index	Type
6-0* Analog I/O Mode						
6-00	Live Zero Timeout Time	10 s	All set-ups	TRUE	0	Uint8
6-01	Live Zero Timeout Function	[0] Off	All set-ups	TRUE	-	Uint8
6-1* Analog Input 53						
6-10	Terminal 53 Low Voltage	0.07 V	All set-ups	TRUE	-2	Int16
6-11	Terminal 53 High Voltage	10.00 V	All set-ups	TRUE	-2	Int16
6-12	Terminal 53 Low Current	4.00 mA	All set-ups	TRUE	-5	Int16
6-13	Terminal 53 High Current	20.00 mA	All set-ups	TRUE	-5	Int16
6-14	Terminal 53 Low Ref./Feedb. Value	0.000 N/A	All set-ups	TRUE	-3	Int32
6-15	Terminal 53 High Ref./Feedb. Value	SR	All set-ups	TRUE	-3	Int32
6-16	Terminal 53 Filter Time Constant	0.001 s	All set-ups	TRUE	-3	Uint16
6-17	Terminal 53 Live Zero	[1] Enabled	All set-ups	TRUE	-	Uint8
6-2* Analog Input 54						
6-20	Terminal 54 Low Voltage	0.07 V	All set-ups	TRUE	-2	Int16
6-21	Terminal 54 High Voltage	10.00 V	All set-ups	TRUE	-2	Int16
6-22	Terminal 54 Low Current	4.00 mA	All set-ups	TRUE	-5	Int16
6-23	Terminal 54 High Current	20.00 mA	All set-ups	TRUE	-5	Int16
6-24	Terminal 54 Low Ref./Feedb. Value	0.000 N/A	All set-ups	TRUE	-3	Int32
6-25	Terminal 54 High Ref./Feedb. Value	100.000 N/A	All set-ups	TRUE	-3	Int32
6-26	Terminal 54 Filter Time Constant	0.001 s	All set-ups	TRUE	-3	Uint16
6-27	Terminal 54 Live Zero	[1] Enabled	All set-ups	TRUE	-	Uint8
6-3* Analog Input X30/11						
6-30	Terminal X30/11 Low Voltage	0.07 V	All set-ups	TRUE	-2	Int16
6-31	Terminal X30/11 High Voltage	10.00 V	All set-ups	TRUE	-2	Int16
6-34	Term. X30/11 Low Ref./Feedb. Value	0.000 N/A	All set-ups	TRUE	-3	Int32
6-35	Term. X30/11 High Ref./Feedb. Value	100.000 N/A	All set-ups	TRUE	-3	Int32
6-36	Term. X30/11 Filter Time Constant	0.001 s	All set-ups	TRUE	-3	Uint16
6-37	Term. X30/11 Live Zero	[1] Enabled	All set-ups	TRUE	-	Uint8
6-4* Analog Input X30/12						
6-40	Terminal X30/12 Low Voltage	0.07 V	All set-ups	TRUE	-2	Int16
6-41	Terminal X30/12 High Voltage	10.00 V	All set-ups	TRUE	-2	Int16
6-44	Term. X30/12 Low Ref./Feedb. Value	0.000 N/A	All set-ups	TRUE	-3	Int32
6-45	Term. X30/12 High Ref./Feedb. Value	100.000 N/A	All set-ups	TRUE	-3	Int32
6-46	Term. X30/12 Filter Time Constant	0.001 s	All set-ups	TRUE	-3	Uint16
6-47	Term. X30/12 Live Zero	[1] Enabled	All set-ups	TRUE	-	Uint8
6-5* Analog Output 42						
6-50	Terminal 42 Output	[100] Output freq. 0-100	All set-ups	TRUE	-	Uint8
6-51	Terminal 42 Output Min Scale	0.00 %	All set-ups	TRUE	-2	Int16
6-52	Terminal 42 Output Max Scale	100.00 %	All set-ups	TRUE	-2	Int16
6-53	Terminal 42 Output Bus Control	0.00 %	All set-ups	TRUE	-2	N2
6-54	Terminal 42 Output Timeout Preset	0.00 %	1 set-up	TRUE	-2	Uint16
6-6* Analog Output X30/8						
6-60	Terminal X30/8 Output	[0] No operation	All set-ups	TRUE	-	Uint8
6-61	Terminal X30/8 Min. Scale	0.00 %	All set-ups	TRUE	-2	Int16
6-62	Terminal X30/8 Max. Scale	100.00 %	All set-ups	TRUE	-2	Int16
6-63	Terminal X30/8 Output Bus Control	0.00 %	All set-ups	TRUE	-2	N2
6-64	Terminal X30/8 Output Timeout Preset	0.00 %	1 set-up	TRUE	-2	Uint16

8.3.9 Comm. and Options 8--**

Par. No. #	Parameter description	Default value	4-set-up	Change during operation	Conversion Index	Type
8-0* General Settings						
8-01	Control Site	null	All set-ups	TRUE	-	Uint8
8-02	Control Source	null	All set-ups	TRUE	-	Uint8
8-03	Control Timeout Time	SR	1 set-up	TRUE	-1	Uint32
8-04	Control Timeout Function	[0] Off	1 set-up	TRUE	-	Uint8
8-05	End-of-Timeout Function	[1] Resume set-up	1 set-up	TRUE	-	Uint8
8-06	Reset Control Timeout	[0] Do not reset	All set-ups	TRUE	-	Uint8
8-07	Diagnosis Trigger	[0] Disable	2 set-ups	TRUE	-	Uint8
8-1* Control Settings						
8-10	Control Profile	[0] FC profile	All set-ups	TRUE	-	Uint8
8-13	Configurable Status Word STW	[1] Profile Default	All set-ups	TRUE	-	Uint8
8-14	Configurable Control Word CTW	[1] Profile default	All set-ups	TRUE	-	Uint8
8-3* FC Port Settings						
8-30	Protocol	null	1 set-up	TRUE	-	Uint8
8-31	Address	SR	1 set-up	TRUE	0	Uint8
8-32	Baud Rate	null	1 set-up	TRUE	-	Uint8
8-33	Parity / Stop Bits	null	1 set-up	TRUE	-	Uint8
8-35	Minimum Response Delay	SR	1 set-up	TRUE	-3	Uint16
8-36	Max Response Delay	SR	1 set-up	TRUE	-3	Uint16
8-37	Maximum Inter-Char Delay	SR	1 set-up	TRUE	-5	Uint16
8-4* FC MC protocol set						
8-40	Telegram Selection	[1] Standard telegram 1	2 set-ups	TRUE	-	Uint8
8-5* Digital / Bus						
8-50	Coasting Select	[3] Logic OR	All set-ups	TRUE	-	Uint8
8-52	DC Brake Select	[3] Logic OR	All set-ups	TRUE	-	Uint8
8-53	Start Select	[3] Logic OR	All set-ups	TRUE	-	Uint8
8-54	Reversing Select	null	All set-ups	TRUE	-	Uint8
8-55	Set-up Select	[3] Logic OR	All set-ups	TRUE	-	Uint8
8-56	Preset Reference Select	[3] Logic OR	All set-ups	TRUE	-	Uint8
8-7* BACnet						
8-70	BACnet Device Instance	1 N/A	1 set-up	TRUE	0	Uint32
8-72	MS/TP Max Masters	127 N/A	1 set-up	TRUE	0	Uint8
8-73	MS/TP Max Info Frames	1 N/A	1 set-up	TRUE	0	Uint16
8-74	"I-Am" Service	[0] Send at power-up	1 set-up	TRUE	-	Uint8
8-75	Initialisation Password	SR	1 set-up	TRUE	0	VisStr[20]
8-8* FC Port Diagnostics						
8-80	Bus Message Count	0 N/A	All set-ups	TRUE	0	Uint32
8-81	Bus Error Count	0 N/A	All set-ups	TRUE	0	Uint32
8-82	Slave Message Rcvd	0 N/A	All set-ups	TRUE	0	Uint32
8-83	Slave Error Count	0 N/A	All set-ups	TRUE	0	Uint32
8-9* Bus Jog / Feedback						
8-90	Bus Jog 1 Speed	100 RPM	All set-ups	TRUE	67	Uint16
8-91	Bus Jog 2 Speed	200 RPM	All set-ups	TRUE	67	Uint16
8-94	Bus Feedback 1	0 N/A	1 set-up	TRUE	0	N2
8-95	Bus Feedback 2	0 N/A	1 set-up	TRUE	0	N2
8-96	Bus Feedback 3	0 N/A	1 set-up	TRUE	0	N2

8.3.10 Profibus 9--***

Par. No.	Parameter description	Default value	4-set-up	FC 302 only	Change during operation	Conversion index	Type
9-00	Setpoint	0 N/A	All set-ups		TRUE	0	Uint16
9-07	Actual Value	0 N/A	All set-ups		FALSE	0	Uint16
9-15	PCD Write Configuration	ExpressionLimit	2 set-ups		TRUE	-	Uint16
9-16	PCD Read Configuration	ExpressionLimit	2 set-ups		TRUE	-	Uint16
9-18	Node Address	126 N/A	1 set-up		TRUE	0	Uint8
9-22	Telegram Selection	[108] PPO 8	1 set-up		TRUE	-	Uint8
9-23	Parameters for Signals	0	All set-ups		TRUE	-	Uint16
9-27	Parameter Edit	[1] Enabled	2 set-ups		FALSE	-	Uint16
9-28	Process Control	[1] Enable cyclic master	2 set-ups		FALSE	-	Uint8
9-44	Fault Message Counter	0 N/A	All set-ups		TRUE	0	Uint16
9-45	Fault Code	0 N/A	All set-ups		TRUE	0	Uint16
9-47	Fault Number	0 N/A	All set-ups		TRUE	0	Uint16
9-52	Fault Situation Counter	0 N/A	All set-ups		TRUE	0	Uint16
9-53	Profibus Warning Word	0 N/A	All set-ups		TRUE	0	V2
9-63	Actual Baud Rate	[255] No baudrate found	All set-ups		TRUE	-	Uint8
9-64	Device Identification	0 N/A	All set-ups		TRUE	0	Uint16
9-65	Profile Number	0 N/A	All set-ups		TRUE	0	OctStr[2]
9-67	Control Word 1	0 N/A	All set-ups		TRUE	0	V2
9-68	Status Word 1	0 N/A	All set-ups		TRUE	0	V2
9-71	Profibus Save Data Values	[0] Off	All set-ups		TRUE	-	Uint8
9-72	ProfibusDriveReset	[0] No action	1 set-up		FALSE	-	Uint8
9-80	Defined Parameters (1)	0 N/A	All set-ups		FALSE	0	Uint16
9-81	Defined Parameters (2)	0 N/A	All set-ups		FALSE	0	Uint16
9-82	Defined Parameters (3)	0 N/A	All set-ups		FALSE	0	Uint16
9-83	Defined Parameters (4)	0 N/A	All set-ups		FALSE	0	Uint16
9-84	Defined Parameters (5)	0 N/A	All set-ups		FALSE	0	Uint16
9-90	Changed Parameters (1)	0 N/A	All set-ups		FALSE	0	Uint16
9-91	Changed Parameters (2)	0 N/A	All set-ups		FALSE	0	Uint16
9-92	Changed Parameters (3)	0 N/A	All set-ups		FALSE	0	Uint16
9-93	Changed Parameters (4)	0 N/A	All set-ups		FALSE	0	Uint16
9-94	Changed Parameters (5)	0 N/A	All set-ups		FALSE	0	Uint16

8.3.11 CAN Fieldbus 10-**

Par. No. #	Parameter description	Default value	4-set-up	Change during operation	Conversion Index	Type
10-0* Common Settings						
10-00	CAN Protocol	null	2 set-ups	FALSE	-	Uint8
10-01	Baud Rate Select	null	2 set-ups	TRUE	-	Uint8
10-02	MAC ID	SR	2 set-ups	TRUE	0	Uint8
10-05	Readout Transmit Error Counter	0 N/A	All set-ups	TRUE	0	Uint8
10-06	Readout Receive Error Counter	0 N/A	All set-ups	TRUE	0	Uint8
10-07	Readout Bus Off Counter	0 N/A	All set-ups	TRUE	0	Uint8
10-1* DeviceNet						
10-10	Process Data Type Selection	null	All set-ups	TRUE	-	Uint8
10-11	Process Data Config Write	SR	2 set-ups	TRUE	-	Uint16
10-12	Process Data Config Read	SR	2 set-ups	TRUE	-	Uint16
10-13	Warning Parameter	0 N/A	All set-ups	TRUE	0	Uint16
10-14	Net Reference	[0] Off	2 set-ups	TRUE	-	Uint8
10-15	Net Control	[0] Off	2 set-ups	TRUE	-	Uint8
10-2* COS Filters						
10-20	COS Filter 1	0 N/A	All set-ups	FALSE	0	Uint16
10-21	COS Filter 2	0 N/A	All set-ups	FALSE	0	Uint16
10-22	COS Filter 3	0 N/A	All set-ups	FALSE	0	Uint16
10-23	COS Filter 4	0 N/A	All set-ups	FALSE	0	Uint16
10-3* Parameter Access						
10-30	Array Index	0 N/A	2 set-ups	TRUE	0	Uint8
10-31	Store Data Values	[0] Off	All set-ups	TRUE	-	Uint8
10-32	DeviceNet Revision	SR	All set-ups	TRUE	0	Uint16
10-33	Store Always	[0] Off	1 set-up	TRUE	-	Uint8
10-34	DeviceNet Product Code	130 N/A	1 set-up	TRUE	0	Uint16
10-39	DeviceNet F Parameters	0 N/A	All set-ups	TRUE	0	Uint32

8.3.12 Smart Logic 13--****

Par. No. #	Parameter description	Default value	4-set-up	Change during operation	Conversion Index	Type
13-0* SLC Settings						
13-00	SL Controller Mode	null	2 set-ups	TRUE	-	Uint8
13-01	Start Event	null	2 set-ups	TRUE	-	Uint8
13-02	Stop Event	null	2 set-ups	TRUE	-	Uint8
13-03	Reset SLC	[0] Do not reset SLC	All set-ups	TRUE	-	Uint8
13-1* Comparators						
13-10	Comparator Operand	null	2 set-ups	TRUE	-	Uint8
13-11	Comparator Operator	null	2 set-ups	TRUE	-	Uint8
13-12	Comparator Value	SR	2 set-ups	TRUE	-3	Int32
13-2* Timers						
13-20	SL Controller Timer	SR	1 set-up	TRUE	-3	TimD
13-4* Logic Rules						
13-40	Logic Rule Boolean 1	null	2 set-ups	TRUE	-	Uint8
13-41	Logic Rule Operator 1	null	2 set-ups	TRUE	-	Uint8
13-42	Logic Rule Boolean 2	null	2 set-ups	TRUE	-	Uint8
13-43	Logic Rule Operator 2	null	2 set-ups	TRUE	-	Uint8
13-44	Logic Rule Boolean 3	null	2 set-ups	TRUE	-	Uint8
13-5* States						
13-51	SL Controller Event	null	2 set-ups	TRUE	-	Uint8
13-52	SL Controller Action	null	2 set-ups	TRUE	-	Uint8

8.3.13 Special Functions 14-**

Par. No. #	Parameter description	Default value	4-set-up	Change during operation	Conversion Index	Type
14-0* Inverter Switching						
14-00	Switching Pattern	null	All set-ups	TRUE	-	Uint8
14-01	Switching Frequency	null	All set-ups	TRUE	-	Uint8
14-03	Overmodulation	[1] On	All set-ups	FALSE	-	Uint8
14-04	PWM Random	[0] Off	All set-ups	TRUE	-	Uint8
14-1* Mains On/Off						
14-10	Mains Failure	[0] No function	All set-ups	FALSE	-	Uint8
14-11	Mains Voltage at Mains Fault	SR	All set-ups	TRUE	0	Uint16
14-12	Function at Mains Imbalance	[3] Derate	All set-ups	TRUE	-	Uint8
14-2* Reset Functions						
14-20	Reset Mode	[10] Automatic reset x 10	All set-ups	TRUE	-	Uint8
14-21	Automatic Restart Time	10 s	All set-ups	TRUE	0	Uint16
14-22	Operation Mode	[0] Normal operation	All set-ups	TRUE	-	Uint8
14-23	Typecode Setting	null	2 set-ups	FALSE	-	Uint8
14-25	Trip Delay at Torque Limit	60 s	All set-ups	TRUE	0	Uint8
14-26	Trip Delay at Inverter Fault	SR	All set-ups	TRUE	0	Uint8
14-28	Production Settings	[0] No action	All set-ups	TRUE	-	Uint8
14-29	Service Code	0 N/A	All set-ups	TRUE	0	Int32
14-3* Current Limit Ctrl.						
14-30	Current Lim Ctrl, Proportional Gain	100 %	All set-ups	FALSE	0	Uint16
14-31	Current Lim Ctrl, Integration Time	0.020 s	All set-ups	FALSE	-3	Uint16
14-32	Current Lim Ctrl, Filter Time	27.0 ms	All set-ups	FALSE	-4	Uint16
14-4* Energy Optimising						
14-40	VT Level	66 %	All set-ups	FALSE	0	Uint8
14-41	AEO Minimum Magnetisation	SR	All set-ups	TRUE	0	Uint8
14-42	Minimum AEO Frequency	10 Hz	All set-ups	TRUE	0	Uint8
14-43	Motor Cosphi	SR	All set-ups	TRUE	-2	Uint16
14-5* Environment						
14-50	RFI Filter	[1] On	1 set-up	FALSE	-	Uint8
14-52	Fan Control	[0] Auto	All set-ups	TRUE	-	Uint8
14-53	Fan Monitor	[1] Warning	All set-ups	TRUE	-	Uint8
14-55	Output Filter	[0] No Filter	1 set-up	FALSE	-	Uint8
14-59	Actual Number of Inverter Units	SR	1 set-up	FALSE	0	Uint8
14-6* Auto Derate						
14-60	Function at Over Temperature	[1] Derate	All set-ups	TRUE	-	Uint8
14-61	Function at Inverter Overload	[1] Derate	All set-ups	TRUE	-	Uint8
14-62	Inv. Overload Derate Current	95 %	All set-ups	TRUE	0	Uint16
14-8* Options						
14-80	Option Supplied by External 24VDC	[0] No	2 set-ups	FALSE	-	Uint8

8.3.14 FC Information 15-.***

Par. No. #	Parameter description	Default value	4-set-up	Change during operation	Conversion index	Type
15-0* Operating Data						
15-00	Operating Hours	0 h	All set-ups	FALSE	74	Uint32
15-01	Running Hours	0 h	All set-ups	FALSE	74	Uint32
15-02	kWh Counter	0 kWh	All set-ups	FALSE	75	Uint32
15-03	Power Up's	0 N/A	All set-ups	FALSE	0	Uint32
15-04	Over Temp's	0 N/A	All set-ups	FALSE	0	Uint16
15-05	Over Volt's	0 N/A	All set-ups	FALSE	0	Uint16
15-06	Reset kWh Counter	[0] Do not reset	All set-ups	TRUE	-	Uint8
15-07	Reset Running Hours Counter	[0] Do not reset	All set-ups	TRUE	-	Uint8
15-08	Number of Starts	0 N/A	All set-ups	FALSE	0	Uint32
15-1* Data Log Settings						
15-10	Logging Source	0	2 set-ups	TRUE	-	Uint16
15-11	Logging Interval	SR	2 set-ups	TRUE	-3	TimD
15-12	Trigger Event	[0] False	1 set-up	TRUE	-	Uint8
15-13	Logging Mode	[0] Log always	2 set-ups	TRUE	-	Uint8
15-14	Samples Before Trigger	50 N/A	2 set-ups	TRUE	0	Uint8
15-2* Historic Log						
15-20	Historic Log: Event	0 N/A	All set-ups	FALSE	0	Uint8
15-21	Historic Log: Value	0 N/A	All set-ups	FALSE	0	Uint32
15-22	Historic Log: Time	0 ms	All set-ups	FALSE	-3	Uint32
15-23	Historic Log: Date and Time	SR	All set-ups	FALSE	0	TimeOfDay
15-3* Alarm Log						
15-30	Alarm Log: Error Code	0 N/A	All set-ups	FALSE	0	Uint16
15-31	Alarm Log: Value	0 N/A	All set-ups	FALSE	0	Int16
15-32	Alarm Log: Time	0 s	All set-ups	FALSE	0	Uint32
15-33	Alarm Log: Date and Time	SR	All set-ups	FALSE	0	TimeOfDay
15-34	Alarm Log: Setpoint	0.000 ProcessCtrlUnit	All set-ups	FALSE	-3	Int32
15-35	Alarm Log: Feedback	0.000 ProcessCtrlUnit	All set-ups	FALSE	-3	Int32
15-36	Alarm Log: Current Demand	0 %	All set-ups	FALSE	0	Uint8
15-37	Alarm Log: Process Ctrl Unit	[0]	All set-ups	FALSE	-	Uint8
15-4* Drive Identification						
15-40	FC Type	0 N/A	All set-ups	FALSE	0	VisStr[6]
15-41	Power Section	0 N/A	All set-ups	FALSE	0	VisStr[20]
15-42	Voltage	0 N/A	All set-ups	FALSE	0	VisStr[20]
15-43	Software Version	0 N/A	All set-ups	FALSE	0	VisStr[5]
15-44	Ordered Typecode String	0 N/A	All set-ups	FALSE	0	VisStr[40]
15-45	Actual Typecode String	0 N/A	All set-ups	FALSE	0	VisStr[40]
15-46	Frequency Converter Ordering No	0 N/A	All set-ups	FALSE	0	VisStr[8]
15-47	Power Card Ordering No	0 N/A	All set-ups	FALSE	0	VisStr[8]
15-48	LCP Id No	0 N/A	All set-ups	FALSE	0	VisStr[20]
15-49	SW ID Control Card	0 N/A	All set-ups	FALSE	0	VisStr[20]
15-50	SW ID Power Card	0 N/A	All set-ups	FALSE	0	VisStr[20]
15-51	Frequency Converter Serial Number	0 N/A	All set-ups	FALSE	0	VisStr[10]
15-53	Power Card Serial Number	0 N/A	All set-ups	FALSE	0	VisStr[19]

Par. No. #	Parameter description	Default value	4-set-up	Change during operation	Conversion index	Type
15-6* Option Ident						
15-60	Option Mounted	0 N/A	All set-ups	FALSE	0	VisStr[30]
15-61	Option SW Version	0 N/A	All set-ups	FALSE	0	VisStr[20]
15-62	Option Ordering No	0 N/A	All set-ups	FALSE	0	VisStr[8]
15-63	Option Serial No	0 N/A	All set-ups	FALSE	0	VisStr[18]
15-70	Option in Slot A	0 N/A	All set-ups	FALSE	0	VisStr[30]
15-71	Slot A Option SW Version	0 N/A	All set-ups	FALSE	0	VisStr[20]
15-72	Option in Slot B	0 N/A	All set-ups	FALSE	0	VisStr[30]
15-73	Slot B Option SW Version	0 N/A	All set-ups	FALSE	0	VisStr[20]
15-74	Option in Slot C0	0 N/A	All set-ups	FALSE	0	VisStr[30]
15-75	Slot C0 Option SW Version	0 N/A	All set-ups	FALSE	0	VisStr[20]
15-76	Option in Slot C1	0 N/A	All set-ups	FALSE	0	VisStr[30]
15-77	Slot C1 Option SW Version	0 N/A	All set-ups	FALSE	0	VisStr[20]
15-9* Parameter Info						
15-92	Defined Parameters	0 N/A	All set-ups	FALSE	0	Uint16
15-93	Modified Parameters	0 N/A	All set-ups	FALSE	0	Uint16
15-98	Drive Identification	0 N/A	All set-ups	FALSE	0	VisStr[40]
15-99	Parameter Metadata	0 N/A	All set-ups	FALSE	0	Uint16

8.3.15 Data Readouts 16--***

Par. No. #	Parameter description	Default value	4-set-up	Change during operation	Conversion index	Type
16-0* General Status						
16-00	Control Word	0 N/A	All set-ups	TRUE	0	V2
16-01	Reference [Unit]	0.000 ReferenceFeedbackUnit	All set-ups	TRUE	-3	Int32
16-02	Reference [%]	0.0 %	All set-ups	TRUE	-1	Int16
16-03	Status Word	0 N/A	All set-ups	TRUE	0	V2
16-05	Main Actual Value [%]	0.00 %	All set-ups	TRUE	-2	N2
16-09	Custom Readout	0.00 CustomReadoutUnit	All set-ups	TRUE	-2	Int32
16-1* Motor Status						
16-10	Power [kW]	0.00 kW	All set-ups	TRUE	1	Int32
16-11	Power [hp]	0.00 hp	All set-ups	TRUE	-2	Int32
16-12	Motor Voltage	0.0 V	All set-ups	TRUE	-1	Uint16
16-13	Frequency	0.0 Hz	All set-ups	TRUE	-1	Uint16
16-14	Motor Current	0.00 A	All set-ups	TRUE	-2	Int32
16-15	Frequency [%]	0.00 %	All set-ups	TRUE	-2	N2
16-16	Torque [Nm]	0.0 Nm	All set-ups	TRUE	-1	Int32
16-17	Speed [RPM]	0 RPM	All set-ups	TRUE	67	Int32
16-18	Motor Thermal	0 %	All set-ups	TRUE	0	Uint8
16-22	Torque [%]	0 %	All set-ups	TRUE	0	Int16
16-3* Drive Status						
16-30	DC Link Voltage	0 V	All set-ups	TRUE	0	Uint16
16-32	Brake Energy /s	0.000 kW	All set-ups	TRUE	0	Uint32
16-33	Brake Energy /2 min	0.000 kW	All set-ups	TRUE	0	Uint32
16-34	Heatsink Temp.	0 °C	All set-ups	TRUE	100	Uint8
16-35	Inverter Thermal	0 %	All set-ups	TRUE	0	Uint8
16-36	Inv. Nom. Current	SR	All set-ups	TRUE	-2	Uint32
16-37	Inv. Max. Current	SR	All set-ups	TRUE	-2	Uint32
16-38	SL Controller State	0 N/A	All set-ups	TRUE	0	Uint8
16-39	Control Card Temp.	0 °C	All set-ups	TRUE	100	Uint8
16-40	Logging Buffer Full	[0] No	All set-ups	TRUE	-	Uint8
16-5* Ref. & Feedb.						
16-50	External Reference	0.0 N/A	All set-ups	TRUE	-1	Int16
16-52	Feedback [Unit]	0.000 ProcessCtrlUnit	All set-ups	TRUE	-3	Int32
16-53	Digi Pot Reference	0.00 N/A	All set-ups	TRUE	-2	Int16
16-54	Feedback 1 [Unit]	0.000 ProcessCtrlUnit	All set-ups	TRUE	-3	Int32
16-55	Feedback 2 [Unit]	0.000 ProcessCtrlUnit	All set-ups	TRUE	-3	Int32
16-56	Feedback 3 [Unit]	0.000 ProcessCtrlUnit	All set-ups	TRUE	-3	Int32
16-58	PID Output [%]	0.0 %	All set-ups	TRUE	-1	Int16
16-59	Adjusted Setpoint	0.000 ProcessCtrlUnit	All set-ups	TRUE	-3	Int32

Par. No. #	Parameter description	Default value	4-set-up	Change during operation	Conversion index	Type
16-6* Inputs & Outputs						
16-60	Digital Input	0 N/A	All set-ups	TRUE	0	Uint16
16-61	Terminal 53 Switch Setting	[0] Current	All set-ups	TRUE	-	Uint8
16-62	Analog Input 53	0.000 N/A	All set-ups	TRUE	-3	Int32
16-63	Terminal 54 Switch Setting	[0] Current	All set-ups	TRUE	-	Uint8
16-64	Analog Input 54	0.000 N/A	All set-ups	TRUE	-3	Int32
16-65	Analog Output 42 [mA]	0.000 N/A	All set-ups	TRUE	-3	Int16
16-66	Digital Output [bin]	0 N/A	All set-ups	TRUE	0	Int16
16-67	Pulse Input #29 [Hz]	0 N/A	All set-ups	TRUE	0	Int32
16-68	Pulse Input #33 [Hz]	0 N/A	All set-ups	TRUE	0	Int32
16-69	Pulse Output #27 [Hz]	0 N/A	All set-ups	TRUE	0	Int32
16-70	Pulse Output #29 [Hz]	0 N/A	All set-ups	TRUE	0	Int32
16-71	Relay Output [bin]	0 N/A	All set-ups	TRUE	0	Uint16
16-72	Counter A	0 N/A	All set-ups	TRUE	0	Int32
16-73	Counter B	0 N/A	All set-ups	TRUE	0	Int32
16-75	Analog In X30/11	0.000 N/A	All set-ups	TRUE	-3	Int32
16-76	Analog In X30/12	0.000 N/A	All set-ups	TRUE	-3	Int32
16-77	Analog Out X30/8 [mA]	0.000 N/A	All set-ups	TRUE	-3	Int16
16-8* Fieldbus & FC Port						
16-80	Fieldbus CTW 1	0 N/A	All set-ups	TRUE	0	V2
16-82	Fieldbus REF 1	0 N/A	All set-ups	TRUE	0	N2
16-84	Comm. Option STW	0 N/A	All set-ups	TRUE	0	V2
16-85	FC Port CTW 1	0 N/A	All set-ups	TRUE	0	V2
16-86	FC Port REF 1	0 N/A	All set-ups	TRUE	0	N2
16-9* Diagnosis Readouts						
16-90	Alarm Word	0 N/A	All set-ups	TRUE	0	Uint32
16-91	Alarm Word 2	0 N/A	All set-ups	TRUE	0	Uint32
16-92	Warning Word	0 N/A	All set-ups	TRUE	0	Uint32
16-93	Warning Word 2	0 N/A	All set-ups	TRUE	0	Uint32
16-94	Ext. Status Word	0 N/A	All set-ups	TRUE	0	Uint32
16-95	Ext. Status Word 2	0 N/A	All set-ups	TRUE	0	Uint32
16-96	Maintenance Word	0 N/A	All set-ups	TRUE	0	Uint32

8.3.16 Data Readouts 2 18-.*

Par. No. #	Parameter description	Default value	4-set-up	Change during operation	Conversion index	Type
18-0* Maintenance Log						
18-00	Maintenance Log: Item	0 N/A	All set-ups	FALSE	0	Uint8
18-01	Maintenance Log: Action	0 N/A	All set-ups	FALSE	0	Uint8
18-02	Maintenance Log: Time	0 s	All set-ups	FALSE	0	Uint32
18-03	Maintenance Log: Date and Time	SR	All set-ups	FALSE	0	TimeOfDay
18-3* Inputs & Outputs						
18-30	Analog Input X42/1	0.000 N/A	All set-ups	FALSE	-3	Int32
18-31	Analog Input X42/3	0.000 N/A	All set-ups	FALSE	-3	Int32
18-32	Analog Input X42/5	0.000 N/A	All set-ups	FALSE	-3	Int32
18-33	Analog Out: X42/7 [V]	0.000 N/A	All set-ups	FALSE	-3	Int16
18-34	Analog Out: X42/9 [V]	0.000 N/A	All set-ups	FALSE	-3	Int16
18-35	Analog Out: X42/11 [V]	0.000 N/A	All set-ups	FALSE	-3	Int16

8.3.17 FC Closed Loop 20-**

Par. No. #	Parameter description	Default value	4-set-up	Change during operation	Conversion Index	Type
20-0* Feedback						
20-00	Feedback 1 Source	[2] Analog input 54	All set-ups	TRUE	-	Uint8
20-01	Feedback 1 Conversion	[0] Linear	All set-ups	FALSE	-	Uint8
20-02	Feedback 1 Source Unit	null	All set-ups	TRUE	-	Uint8
20-03	Feedback 2 Source	[0] No function	All set-ups	TRUE	-	Uint8
20-04	Feedback 2 Conversion	[0] Linear	All set-ups	FALSE	-	Uint8
20-05	Feedback 2 Source Unit	null	All set-ups	TRUE	-	Uint8
20-06	Feedback 3 Source	[0] No function	All set-ups	TRUE	-	Uint8
20-07	Feedback 3 Conversion	[0] Linear	All set-ups	FALSE	-	Uint8
20-08	Feedback 3 Source Unit	null	All set-ups	TRUE	-	Uint8
20-12	Reference/Feedback Unit	null	All set-ups	TRUE	-	Uint8
20-2* Feedback/Setpoint						
20-20	Feedback Function	[4] Maximum	All set-ups	TRUE	-	Uint8
20-21	Setpoint 1	0.000 ProcessCtrlUnit	All set-ups	TRUE	-3	Int32
20-22	Setpoint 2	0.000 ProcessCtrlUnit	All set-ups	TRUE	-3	Int32
20-23	Setpoint 3	0.000 ProcessCtrlUnit	All set-ups	TRUE	-3	Int32
20-7* PID Autotuning						
20-70	Closed Loop Type	[0] Auto	2 set-ups	TRUE	-	Uint8
20-71	PID Performance	[0] Normal	2 set-ups	TRUE	-	Uint8
20-72	PID Output Change	0.10 N/A	2 set-ups	TRUE	-2	Uint16
20-73	Minimum Feedback Level	-999999.000 ProcessCtrlUnit	2 set-ups	TRUE	-3	Int32
20-74	Maximum Feedback Level	999999.000 ProcessCtrlUnit	2 set-ups	TRUE	-3	Int32
20-79	PID Autotuning	[0] Disabled	All set-ups	TRUE	-	Uint8
20-8* PID Basic Settings						
20-81	PID Normal/ Inverse Control	[0] Normal	All set-ups	TRUE	-	Uint8
20-82	PID Start Speed [RPM]	SR	All set-ups	TRUE	67	Uint16
20-83	PID Start Speed [Hz]	SR	All set-ups	TRUE	-1	Uint16
20-84	On Reference Bandwidth	5 %	All set-ups	TRUE	0	Uint8
20-9* PID Controller						
20-91	PID Anti Windup	[1] On	All set-ups	TRUE	-	Uint8
20-93	PID Proportional Gain	2.00 N/A	All set-ups	TRUE	-2	Uint16
20-94	PID Integral Time	8.00 s	All set-ups	TRUE	-2	Uint32
20-95	PID Differentiation Time	0.00 s	All set-ups	TRUE	-2	Uint16
20-96	PID Diff. Gain Limit	5.0 N/A	All set-ups	TRUE	-1	Uint16



8.3.18 Ext. Closed Loop 21-.*

Par. No. #	Parameter description	Default value	4-set-up	Change during operation	Conversion Index	Type
21-0*	Ext. CL Autotuning					
21-00	Closed Loop Type	[0] Auto	2 set-ups	TRUE	-	Uint8
21-01	PID Performance	[0] Normal	2 set-ups	TRUE	-	Uint8
21-02	PID Output Change	0.10 N/A	2 set-ups	TRUE	-2	Uint16
21-03	Minimum Feedback Level	-999999.000 N/A	2 set-ups	TRUE	-3	Int32
21-04	Maximum Feedback Level	999999.000 N/A	2 set-ups	TRUE	-3	Int32
21-09	PID Auto Tuning	[0] Disabled	All set-ups	TRUE	-	Uint8
21-1*	Ext. CL 1 Ref./Fb.					
21-10	Ext. 1 Ref./Feedback Unit	[0]	All set-ups	TRUE	-	Uint8
21-11	Ext. 1 Minimum Reference	0.000 ExtPID1Unit	All set-ups	TRUE	-3	Int32
21-12	Ext. 1 Maximum Reference	100.000 ExtPID1Unit	All set-ups	TRUE	-3	Int32
21-13	Ext. 1 Reference Source	[0] No function	All set-ups	TRUE	-	Uint8
21-14	Ext. 1 Feedback Source	[0] No function	All set-ups	TRUE	-	Uint8
21-15	Ext. 1 Setpoint	0.000 ExtPID1Unit	All set-ups	TRUE	-3	Int32
21-17	Ext. 1 Reference [Unit]	0.000 ExtPID1Unit	All set-ups	TRUE	-3	Int32
21-18	Ext. 1 Feedback [Unit]	0.000 ExtPID1Unit	All set-ups	TRUE	-3	Int32
21-19	Ext. 1 Output [%]	0 %	All set-ups	TRUE	0	Int32
21-2*	Ext. CL 1 PID					
21-20	Ext. 1 Normal/Inverse Control	[0] Normal	All set-ups	TRUE	-	Uint8
21-21	Ext. 1 Proportional Gain	0.50 N/A	All set-ups	TRUE	-2	Uint16
21-22	Ext. 1 Integral Time	20.00 s	All set-ups	TRUE	-2	Uint32
21-23	Ext. 1 Differentiation Time	0.00 s	All set-ups	TRUE	-2	Uint16
21-24	Ext. 1 Dif. Gain Limit	5.0 N/A	All set-ups	TRUE	-1	Uint16
21-3*	Ext. CL 2 Ref./Fb.					
21-30	Ext. 2 Ref./Feedback Unit	[0]	All set-ups	TRUE	-	Uint8
21-31	Ext. 2 Minimum Reference	0.000 ExtPID2Unit	All set-ups	TRUE	-3	Int32
21-32	Ext. 2 Maximum Reference	100.000 ExtPID2Unit	All set-ups	TRUE	-3	Int32
21-33	Ext. 2 Reference Source	[0] No function	All set-ups	TRUE	-	Uint8
21-34	Ext. 2 Feedback Source	[0] No function	All set-ups	TRUE	-	Uint8
21-35	Ext. 2 Setpoint	0.000 ExtPID2Unit	All set-ups	TRUE	-3	Int32
21-37	Ext. 2 Reference [Unit]	0.000 ExtPID2Unit	All set-ups	TRUE	-3	Int32
21-38	Ext. 2 Feedback [Unit]	0.000 ExtPID2Unit	All set-ups	TRUE	-3	Int32
21-39	Ext. 2 Output [%]	0 %	All set-ups	TRUE	0	Int32
21-4*	Ext. CL 2 PID					
21-40	Ext. 2 Normal/Inverse Control	[0] Normal	All set-ups	TRUE	-	Uint8
21-41	Ext. 2 Proportional Gain	0.50 N/A	All set-ups	TRUE	-2	Uint16
21-42	Ext. 2 Integral Time	20.00 s	All set-ups	TRUE	-2	Uint32
21-43	Ext. 2 Differentiation Time	0.00 s	All set-ups	TRUE	-2	Uint16
21-44	Ext. 2 Dif. Gain Limit	5.0 N/A	All set-ups	TRUE	-1	Uint16

Par. No. #	Parameter description	Default value	4-set-up	Change during operation	Conversion index	Type
21-5*	Ext. Cl. 3 Ref./Fb.					
21-50	Ext. 3 Ref./Feedback Unit	[0]	All set-ups	TRUE	-	Uint8
21-51	Ext. 3 Minimum Reference	0.000 ExtPID3Unit	All set-ups	TRUE	-3	Int32
21-52	Ext. 3 Maximum Reference	100.000 ExtPID3Unit	All set-ups	TRUE	-3	Int32
21-53	Ext. 3 Reference Source	[0] No function	All set-ups	TRUE	-	Uint8
21-54	Ext. 3 Feedback Source	[0] No function	All set-ups	TRUE	-	Uint8
21-55	Ext. 3 Setpoint	0.000 ExtPID3Unit	All set-ups	TRUE	-3	Int32
21-57	Ext. 3 Reference [Unit]	0.000 ExtPID3Unit	All set-ups	TRUE	-3	Int32
21-58	Ext. 3 Feedback [Unit]	0.000 ExtPID3Unit	All set-ups	TRUE	-3	Int32
21-59	Ext. 3 Output [%]	0 %	All set-ups	TRUE	0	Int32
21-6*	Ext. Cl. 3 PID					
21-60	Ext. 3 Normal/Inverse Control	[0] Normal	All set-ups	TRUE	-	Uint8
21-61	Ext. 3 Proportional Gain	0.50 N/A	All set-ups	TRUE	-2	Uint16
21-62	Ext. 3 Integral Time	20.00 s	All set-ups	TRUE	-2	Uint32
21-63	Ext. 3 Differentiation Time	0.00 s	All set-ups	TRUE	-2	Uint16
21-64	Ext. 3 Dif. Gain Limit	5.0 N/A	All set-ups	TRUE	-1	Uint16

8.3.19 Application Functions 22-**

Par. No. #	Parameter description	Default value	4-set-up	Change during operation	Conversion index	Type
22-0* Miscellaneous						
22-00	External Interlock Delay	0 s	All set-ups	TRUE	0	Uint16
22-2* No-Flow Detection						
22-20	Low Power Auto Set-up	[0] Off	All set-ups	FALSE	-	Uint8
22-21	Low Power Detection	[0] Disabled	All set-ups	TRUE	-	Uint8
22-22	Low Speed Detection	[0] Disabled	All set-ups	TRUE	-	Uint8
22-23	No-Flow Function	[0] Off	All set-ups	TRUE	-	Uint8
22-24	No-Flow Delay	10 s	All set-ups	TRUE	0	Uint16
22-26	Dry Pump Function	[0] Off	All set-ups	TRUE	-	Uint8
22-27	Dry Pump Delay	10 s	All set-ups	TRUE	0	Uint16
22-28	No-Flow Low Speed [RPM]	SR	All set-ups	TRUE	67	Uint16
22-29	No-Flow Low Speed [Hz]	SR	All set-ups	TRUE	-1	Uint16
22-3* No-Flow Power Tuning						
22-30	No-Flow Power	0.0 kW	All set-ups	TRUE	1	Uint32
22-31	Power Correction Factor	100 %	All set-ups	TRUE	0	Uint16
22-32	Low Speed [RPM]	SR	All set-ups	TRUE	67	Uint16
22-33	Low Speed [Hz]	SR	All set-ups	TRUE	-1	Uint16
22-34	Low Speed Power [kW]	SR	All set-ups	TRUE	1	Uint32
22-35	Low Speed Power [HP]	SR	All set-ups	TRUE	-2	Uint32
22-36	High Speed [RPM]	SR	All set-ups	TRUE	67	Uint16
22-37	High Speed [Hz]	SR	All set-ups	TRUE	-1	Uint16
22-38	High Speed Power [kW]	SR	All set-ups	TRUE	1	Uint32
22-39	High Speed Power [HP]	SR	All set-ups	TRUE	-2	Uint32
22-4* Sleep Mode						
22-40	Minimum Run Time	60 s	All set-ups	TRUE	0	Uint16
22-41	Minimum Sleep Time	30 s	All set-ups	TRUE	0	Uint16
22-42	Wake-up Speed [RPM]	SR	All set-ups	TRUE	67	Uint16
22-43	Wake-up Speed [Hz]	SR	All set-ups	TRUE	-1	Uint16
22-44	Wake-up Ref./FB Difference	10 %	All set-ups	TRUE	0	Int8
22-45	Setpoint Boost	0 %	All set-ups	TRUE	0	Int8
22-46	Maximum Boost Time	60 s	All set-ups	TRUE	0	Uint16
22-5* End of Curve						
22-50	End of Curve Function	[0] Off	All set-ups	TRUE	-	Uint8
22-51	End of Curve Delay	10 s	All set-ups	TRUE	0	Uint16
22-6* Broken Belt Detection						
22-60	Broken Belt Function	[0] Off	All set-ups	TRUE	-	Uint8
22-61	Broken Belt Torque	10 %	All set-ups	TRUE	0	Uint8
22-62	Broken Belt Delay	10 s	All set-ups	TRUE	0	Uint16
22-7* Short Cycle Protection						
22-75	Short Cycle Protection	[0] Disabled	All set-ups	TRUE	-	Uint8
22-76	Interval between Starts	start_to_start_min_on_time (P2277)	All set-ups	TRUE	0	Uint16
22-77	Minimum Run Time	0 s	All set-ups	TRUE	0	Uint16

Par. No. #	Parameter description	Default value	4-set-up	Change during operation	Conversion index	Type
22-8* Flow Compensation						
22-80	Flow Compensation	[0] Disabled	All set-ups	TRUE	-	Uint8
22-81	Square-linear Curve Approximation	100 %	All set-ups	TRUE	0	Uint8
22-82	Work Point Calculation	[0] Disabled	All set-ups	TRUE	-	Uint8
22-83	Speed at No-Flow [RPM]	SR	All set-ups	TRUE	67	Uint16
22-84	Speed at No-Flow [Hz]	SR	All set-ups	TRUE	-1	Uint16
22-85	Speed at Design Point [RPM]	SR	All set-ups	TRUE	67	Uint16
22-86	Speed at Design Point [Hz]	SR	All set-ups	TRUE	-1	Uint16
22-87	Pressure at No-Flow Speed	0.000 N/A	All set-ups	TRUE	-3	Int32
22-88	Pressure at Rated Speed	999999;999 N/A	All set-ups	TRUE	-3	Int32
22-89	Flow at Design Point	0.000 N/A	All set-ups	TRUE	-3	Int32
22-90	Flow at Rated Speed	0.000 N/A	All set-ups	TRUE	-3	Int32

8.3.20 Timed Actions 23-*.**

Par. No. #	Parameter description	Default value	4-set-up	Change during operation	Conversion Index	Type
23-0* Timed Actions						
23-00	ON Time	SR	2 set-ups	TRUE	0	TimeOfDay- WoDate
23-01	ON Action	[0] Disabled	2 set-ups	TRUE	-	Uint8
23-02	OFF Time	SR	2 set-ups	TRUE	0	TimeOfDay- WoDate
23-03	OFF Action	[0] Disabled	2 set-ups	TRUE	-	Uint8
23-04	Occurrence	[0] All days	2 set-ups	TRUE	-	Uint8
23-1* Maintenance						
23-10	Maintenance Item	[1] Motor bearings	1 set-up	TRUE	-	Uint8
23-11	Maintenance Action	[1] Lubricate	1 set-up	TRUE	-	Uint8
23-12	Maintenance Time Base	[0] Disabled	1 set-up	TRUE	-	Uint8
23-13	Maintenance Time Interval	1 h	1 set-up	TRUE	74	Uint32
23-14	Maintenance Date and Time	SR	1 set-up	TRUE	0	TimeOfDay
23-1* Maintenance Reset						
23-15	Reset Maintenance Word	[0] Do not reset	All set-ups	TRUE	-	Uint8
23-16	Maintenance Text	0 N/A	1 set-up	TRUE	0	VisStr[20]
23-5* Energy Log						
23-50	Energy Log Resolution	[5] Last 24 Hours	2 set-ups	TRUE	-	Uint8
23-51	Period Start	SR	2 set-ups	TRUE	0	TimeOfDay
23-53	Energy Log	0 N/A	All set-ups	TRUE	0	Uint32
23-54	Reset Energy Log	[0] Do not reset	All set-ups	TRUE	-	Uint8
23-6* Trending						
23-60	Trend Variable	[0] Power [kW]	2 set-ups	TRUE	-	Uint8
23-61	Continuous Bin Data	0 N/A	All set-ups	TRUE	0	Uint32
23-62	Timed Bin Data	0 N/A	All set-ups	TRUE	0	Uint32
23-63	Timed Period Start	SR	2 set-ups	TRUE	0	TimeOfDay
23-64	Timed Period Stop	SR	2 set-ups	TRUE	0	TimeOfDay
23-65	Minimum Bin Value	SR	2 set-ups	TRUE	0	Uint8
23-66	Reset Continuous Bin Data	[0] Do not reset	All set-ups	TRUE	-	Uint8
23-67	Reset Timed Bin Data	[0] Do not reset	All set-ups	TRUE	-	Uint8
23-8* Payback Counter						
23-80	Power Reference Factor	100 %	2 set-ups	TRUE	0	Uint8
23-81	Energy Cost	1.00 N/A	2 set-ups	TRUE	-2	Uint32
23-82	Investment	0 N/A	2 set-ups	TRUE	0	Uint32
23-83	Energy Savings	0 kWh	All set-ups	TRUE	75	Int32
23-84	Cost Savings	0 N/A	All set-ups	TRUE	0	Int32

8.3.2.1 Cascade Controller 25-**

Par. No. #	Parameter description	Default value	4-set-up	Change during operation	Conversion index	Type
25-0* System Settings						
25-00	Cascade Controller	null	2 set-ups	FALSE	-	Uint8
25-02	Motor Start	[0] Direct on Line	2 set-ups	FALSE	-	Uint8
25-04	Pump Cycling	null	All set-ups	TRUE	-	Uint8
25-05	Fixed Lead Pump	null	2 set-ups	FALSE	-	Uint8
25-06	Number of Pumps	2 N/A	2 set-ups	FALSE	0	Uint8
25-2* Bandwidth Settings						
25-20	Staging Bandwidth	SR	All set-ups	TRUE	0	Uint8
25-21	Override Bandwidth	100 %	All set-ups	TRUE	0	Uint8
25-22	Fixed Speed Bandwidth	casco_staging_bandwidth (P2520)	All set-ups	TRUE	0	Uint8
25-23	SBW Staging Delay	15 s	All set-ups	TRUE	0	Uint16
25-24	SBW Destaging Delay	15 s	All set-ups	TRUE	0	Uint16
25-25	OBW Time	10 s	All set-ups	TRUE	0	Uint16
25-26	Destage At No-Flow	[0] Disabled	All set-ups	TRUE	-	Uint8
25-27	Stage Function	null	All set-ups	TRUE	-	Uint8
25-28	Stage Function Time	15 s	All set-ups	TRUE	0	Uint16
25-29	Destage Function	null	All set-ups	TRUE	-	Uint8
25-30	Destage Function Time	15 s	All set-ups	TRUE	0	Uint16
25-4* Staging Settings						
25-40	Ramp Down Delay	10.0 s	All set-ups	TRUE	-1	Uint16
25-41	Ramp Up Delay	2.0 s	All set-ups	TRUE	-1	Uint16
25-42	Staging Threshold	SR	All set-ups	TRUE	0	Uint8
25-43	Destaging Threshold	SR	All set-ups	TRUE	0	Uint8
25-44	Staging Speed [RPM]	0 RPM	All set-ups	TRUE	67	Uint16
25-45	Staging Speed [Hz]	0.0 Hz	All set-ups	TRUE	-1	Uint16
25-46	Destaging Speed [RPM]	0 RPM	All set-ups	TRUE	67	Uint16
25-47	Destaging Speed [Hz]	0.0 Hz	All set-ups	TRUE	-1	Uint16
25-5* Alternation Settings						
25-50	Lead Pump Alternation	null	All set-ups	TRUE	-	Uint8
25-51	Alternation Event	[0] External	All set-ups	TRUE	-	Uint8
25-52	Alternation Time Interval	24 h	All set-ups	TRUE	74	Uint16
25-53	Alternation Timer Value	0 N/A	All set-ups	TRUE	0	VisStr[7]
25-54	Alternation Predefined Time	SR	All set-ups	TRUE	0	WoDate
25-55	Alternate if Load < 50%	[1] Enabled	All set-ups	TRUE	-	Uint8
25-56	Staging Mode at Alternation	[0] Slow	All set-ups	TRUE	-	Uint8
25-58	Run Next Pump Delay	0.1 s	All set-ups	TRUE	-1	Uint16
25-59	Run on Mains Delay	0.5 s	All set-ups	TRUE	-1	Uint16

Par. No. #	Parameter description	Default value	4-set-up	Change during operation	Conversion index	Type
25-8* Status						
25-80	Cascade Status	0 N/A	All set-ups	TRUE	0	VisStr[25]
25-81	Pump Status	0 N/A	All set-ups	TRUE	0	VisStr[25]
25-82	Lead Pump	0 N/A	All set-ups	TRUE	0	Uint8
25-83	Relay Status	0 N/A	All set-ups	TRUE	0	VisStr[4]
25-84	Pump ON Time	0 h	All set-ups	TRUE	74	Uint32
25-85	Relay ON Time	0 h	All set-ups	TRUE	74	Uint32
25-86	Reset Relay Counters	[0] Do not reset	All set-ups	TRUE	-	Uint8
25-9* Service						
25-90	Pump Interlock	[0] Off	All set-ups	TRUE	-	Uint8
25-91	Manual Alternation	0 N/A	All set-ups	TRUE	0	Uint8

8.3.2.2 Analog I/O Option MCB 109 26-**

Par. No. #	Parameter description	Default value	4-set-up	Change during operation	Conversion Index	Type
26-0* Analog I/O Mode						
26-00	Terminal X42/1 Mode	[1] Voltage	All set-ups	TRUE	-	Uint8
26-01	Terminal X42/3 Mode	[1] Voltage	All set-ups	TRUE	-	Uint8
26-02	Terminal X42/5 Mode	[1] Voltage	All set-ups	TRUE	-	Uint8
26-1* Analog Input X42/1						
26-10	Terminal X42/1 Low Voltage	0.07 V	All set-ups	TRUE	-2	Int16
26-11	Terminal X42/1 High Voltage	10.00 V	All set-ups	TRUE	-2	Int16
26-14	Term. X42/1 Low Ref./Feedb. Value	0.000 N/A	All set-ups	TRUE	-3	Int32
26-15	Term. X42/1 High Ref./Feedb. Value	100.000 N/A	All set-ups	TRUE	-3	Int32
26-16	Term. X42/1 Filter Time Constant	0.001 s	All set-ups	TRUE	-3	Uint16
26-17	Term. X42/1 Live Zero	[1] Enabled	All set-ups	TRUE	-	Uint8
26-2* Analog Input X42/3						
26-20	Terminal X42/3 Low Voltage	0.07 V	All set-ups	TRUE	-2	Int16
26-21	Terminal X42/3 High Voltage	10.00 V	All set-ups	TRUE	-2	Int16
26-24	Term. X42/3 Low Ref./Feedb. Value	0.000 N/A	All set-ups	TRUE	-3	Int32
26-25	Term. X42/3 High Ref./Feedb. Value	100.000 N/A	All set-ups	TRUE	-3	Int32
26-26	Term. X42/3 Filter Time Constant	0.001 s	All set-ups	TRUE	-3	Uint16
26-27	Term. X42/3 Live Zero	[1] Enabled	All set-ups	TRUE	-	Uint8
26-3* Analog Input X42/5						
26-30	Terminal X42/5 Low Voltage	0.07 V	All set-ups	TRUE	-2	Int16
26-31	Terminal X42/5 High Voltage	10.00 V	All set-ups	TRUE	-2	Int16
26-34	Term. X42/5 Low Ref./Feedb. Value	0.000 N/A	All set-ups	TRUE	-3	Int32
26-35	Term. X42/5 High Ref./Feedb. Value	100.000 N/A	All set-ups	TRUE	-3	Int32
26-36	Term. X42/5 Filter Time Constant	0.001 s	All set-ups	TRUE	-3	Uint16
26-37	Term. X42/5 Live Zero	[1] Enabled	All set-ups	TRUE	-	Uint8
26-4* Analog Out X42/7						
26-40	Terminal X42/7 Output	[0] No operation	All set-ups	TRUE	-	Uint8
26-41	Terminal X42/7 Min. Scale	0.00 %	All set-ups	TRUE	-2	Int16
26-42	Terminal X42/7 Max. Scale	100.00 %	All set-ups	TRUE	-2	Int16
26-43	Terminal X42/7 Bus Control	0.00 %	All set-ups	TRUE	-2	N2
26-44	Terminal X42/7 Timeout Preset	0.00 %	1 set-up	TRUE	-2	Uint16
26-5* Analog Out X42/9						
26-50	Terminal X42/9 Output	[0] No operation	All set-ups	TRUE	-	Uint8
26-51	Terminal X42/9 Min. Scale	0.00 %	All set-ups	TRUE	-2	Int16
26-52	Terminal X42/9 Max. Scale	100.00 %	All set-ups	TRUE	-2	Int16
26-53	Terminal X42/9 Bus Control	0.00 %	All set-ups	TRUE	-2	N2
26-54	Terminal X42/9 Timeout Preset	0.00 %	1 set-up	TRUE	-2	Uint16
26-6* Analog Out X42/11						
26-60	Terminal X42/11 Output	[0] No operation	All set-ups	TRUE	-	Uint8
26-61	Terminal X42/11 Min. Scale	0.00 %	All set-ups	TRUE	-2	Int16
26-62	Terminal X42/11 Max. Scale	100.00 %	All set-ups	TRUE	-2	Int16
26-63	Terminal X42/11 Bus Control	0.00 %	All set-ups	TRUE	-2	N2
26-64	Terminal X42/11 Timeout Preset	0.00 %	1 set-up	TRUE	-2	Uint16

8.3.23 Parameter Lists - Group 27-**

Par. No. #	Parameter description	Default value	4-set-up	Change during operation	Conversion index	Type
27-0* Control & Status						
27-01	Pump Status	[0] Ready	All set-ups	TRUE	-	Uint8
27-02	Manual Pump Control	[0] No Operation	2 set-ups	TRUE	-	Uint8
27-03	Current Runtime Hours	0 h	All set-ups	TRUE	74	Uint32
27-04	Pump Total Lifetime Hours	0 h	All set-ups	TRUE	74	Uint32
27-1* Configuration						
27-10	Cascade Controller	[0] Disabled	2 set-ups	FALSE	-	Uint8
27-11	Number Of Drives	1 N/A	2 set-ups	FALSE	0	Uint8
27-12	Number Of Pumps	SR	2 set-ups	FALSE	0	Uint8
27-14	Pump Capacity	100 %	2 set-ups	FALSE	0	Uint16
27-16	Runtime Balancing	[0] Balanced Priority 1	2 set-ups	TRUE	-	Uint8
27-17	Motor Starters	[0] Direct Online	2 set-ups	FALSE	-	Uint8
27-18	Spin Time for Unused Pumps	SR	All set-ups	TRUE	0	Uint16
27-19	Reset Current Runtime Hours	[0] Do not reset	All set-ups	TRUE	-	Uint8
27-2* Bandwidth Settings						
27-20	Normal Operating Range	SR	All set-ups	TRUE	0	Uint8
27-21	Override Limit	100 %	All set-ups	TRUE	0	Uint8
27-22	Fixed Speed Only Operating Range	SR	All set-ups	TRUE	0	Uint8
27-23	Staging Delay	15 s	All set-ups	TRUE	0	Uint16
27-24	Destaging Delay	15 s	All set-ups	TRUE	0	Uint16
27-25	Override Hold Time	10 s	All set-ups	TRUE	0	Uint16
27-27	Min Speed Destage Delay	SR	All set-ups	TRUE	0	Uint16
27-3* Staging Speed						
27-30	Auto Tune Staging Speeds	[1] Enabled	All set-ups	TRUE	-	Uint8
27-31	Stage On Speed [RPM]	SR	All set-ups	TRUE	67	Uint16
27-32	Stage On Speed [Hz]	SR	All set-ups	TRUE	-1	Uint16
27-33	Stage Off Speed [RPM]	SR	All set-ups	TRUE	67	Uint16
27-34	Stage Off Speed [Hz]	SR	All set-ups	TRUE	-1	Uint16
27-4* Staging Settings						
27-40	Auto Tune Staging Settings	[0] Disabled	All set-ups	TRUE	-	Uint8
27-41	Ramp Down Delay	10.0 s	All set-ups	TRUE	-1	Uint16
27-42	Ramp Up Delay	2.0 s	All set-ups	TRUE	-1	Uint16
27-43	Staging Threshold	SR	All set-ups	TRUE	0	Uint8
27-44	Destaging Threshold	SR	All set-ups	TRUE	0	Uint8
27-45	Staging Speed [RPM]	0 RPM	All set-ups	TRUE	67	Uint16
27-46	Staging Speed [Hz]	0.0 Hz	All set-ups	TRUE	-1	Uint16
27-47	Destaging Speed [RPM]	0 RPM	All set-ups	TRUE	67	Uint16
27-48	Destaging Speed [Hz]	0.0 Hz	All set-ups	TRUE	-1	Uint16

Par. No. #	Parameter description	Default value	4-set-up	Change during operation	Conversion index	Type
27-5* Alternate Settings						
27-50	Automatic Alternation	[0] Disabled	All set-ups	FALSE	-	Uint8
27-51	Alternation Event	null	All set-ups	TRUE	-	Uint8
27-52	Alternation Time Interval	0 min	All set-ups	TRUE	70	Uint16
27-53	Alternation Timer Value	0 min	All set-ups	TRUE	70	Uint16
27-54	Alternation At Time of Day	[0] Disabled	All set-ups	TRUE	-	Uint8
27-55	Alternation Predefined Time	SR	All set-ups	TRUE	0	TimeOfDayWoDate
27-56	Alternate Capacity is <	0 %	All set-ups	TRUE	0	Uint8
27-58	Run Next Pump Delay	0.1 s	All set-ups	TRUE	-1	Uint16
27-6* Digital Inputs						
27-60	Terminal X66/1 Digital Input	[0] No operation	All set-ups	TRUE	-	Uint8
27-61	Terminal X66/3 Digital Input	[0] No operation	All set-ups	TRUE	-	Uint8
27-62	Terminal X66/5 Digital Input	[0] No operation	All set-ups	TRUE	-	Uint8
27-63	Terminal X66/7 Digital Input	[0] No operation	All set-ups	TRUE	-	Uint8
27-64	Terminal X66/9 Digital Input	[0] No operation	All set-ups	TRUE	-	Uint8
27-65	Terminal X66/11 Digital Input	[0] No operation	All set-ups	TRUE	-	Uint8
27-66	Terminal X66/13 Digital Input	[0] No operation	All set-ups	TRUE	-	Uint8
27-7* Connections						
27-70	Relay	[0] Standard Relay	2 set-ups	FALSE	-	Uint8
27-9* Readouts						
27-91	Cascade Reference	0.0 %	All set-ups	TRUE	-1	Int16
27-92	% Of Total Capacity	0 %	All set-ups	TRUE	0	Uint16
27-93	Cascade Option Status	[0] Disabled	All set-ups	TRUE	-	Uint8
27-94	Cascade System Status	0 N/A	All set-ups	TRUE	0	VisStr[25]

8.3.24 Water Application Functions 29-**

Par. No. #	Parameter description	Default value	4-set-up	Change during operation	Conversion index	Type
29-0* Pipe Fill						
29-00	Pipe Fill Enable	[0] Disabled	2 set-ups	FALSE	-	UInt8
29-01	Pipe Fill Speed [RPM]	SR	All set-ups	TRUE	67	UInt16
29-02	Pipe Fill Speed [Hz]	SR	All set-ups	TRUE	-1	UInt16
29-03	Pipe Fill Time	0.00 s	All set-ups	TRUE	-2	UInt32
29-04	Pipe Fill Rate	0.001 ProcessCtrlUnit	All set-ups	TRUE	-3	Int32
29-05	Filled Setpoint	0.000 ProcessCtrlUnit	All set-ups	TRUE	-3	Int32

8.3.25 Bypass Option 31-**-*

Par. No. #	Parameter description	Default value	4-set-up	Change during operation	Conversion index	Type
31-00	Bypass Mode	[0] Drive	All set-ups	TRUE	-	Uint8
31-01	Bypass Start Time Delay	30 s	All set-ups	TRUE	0	Uint16
31-02	Bypass Trip Time Delay	0 s	All set-ups	TRUE	0	Uint16
31-03	Test Mode Activation	[0] Disabled	All set-ups	TRUE	-	Uint8
31-10	Bypass Status Word	0 N/A	All set-ups	FALSE	0	V2
31-11	Bypass Running Hours	0 h	All set-ups	FALSE	74	Uint32
31-19	Remote Bypass Activation	[0] Disabled	2 set-ups	TRUE	-	Uint8

9 Troubleshooting

9.1 Alarms and Warnings

A warning or an alarm is signalled by the relevant LED on the front of the frequency converter and indicated by a code on the display.

A warning remains active until its cause is no longer present. Under certain circumstances operation of the motor may still be continued. Warning messages may be critical, but are not necessarily so.

In the event of an alarm, the frequency converter will have tripped. Alarms must be reset to restart operation once their cause has been rectified.

This may be done in four ways:

1. By using the [RESET] control button on the LCP control panel.
2. Via a digital input with the "Reset" function.
3. Via serial communication/optional fieldbus.
4. By resetting automatically using the [Auto Reset] function, which is a default setting for Automation VT Drive. See par. 14-20 *Reset Mode* in **Automation VT Drive Programming Guide**.



NB!

After a manual reset using the [RESET] button on the , the [AUTO ON] or [HAND ON] button must be pressed to restart the motor.

If an alarm cannot be reset, the reason may be that its cause has not been rectified, or the alarm is trip-locked (see also table on following page).

Alarms that are trip-locked offer additional protection, means that the mains supply must be switched off before the alarm can be reset. After being switched back on, the frequency converter is no longer blocked and may be reset as described above once the cause has been rectified.

Alarms that are not trip-locked can also be reset using the automatic reset function in par. 14-20 *Reset Mode* (Warning: automatic wake-up is possible!)

If a warning and alarm is marked against a code in the table on the following page, this means that either a warning occurs before an alarm, or it can be specified whether it is a warning or an alarm that is to be displayed for a given fault.

This is possible, for instance, in par. 1-90 *Motor Thermal Protection*. After an alarm or trip, the motor carries on coasting, and the alarm and warning flash on the frequency converter. Once the problem has been rectified, only the alarm continues flashing.

No.	Description	Warning	Alarm/Trip	Alarm/Trip Lock	Parameter Reference
1	10 Volts low	X			
2	Live zero error	(X)	(X)		6-01
3	No motor	(X)			1-80
4	Mains phase loss	(X)	(X)	(X)	14-12
5	DC link voltage high	X			
6	DC link voltage low	X			
7	DC over voltage	X	X		
8	DC under voltage	X	X		
9	Inverter overloaded	X	X		
10	Motor ETR over temperature	(X)	(X)		1-90
11	Motor thermistor over temperature	(X)	(X)		1-90
12	Torque limit	X	X		
13	Over Current	X	X	X	
14	Earth fault	X	X	X	
15	Hardware mismatch		X	X	
16	Short Circuit		X	X	
17	Control word timeout	(X)	(X)		8-04
23	Internal Fan Fault	X			
24	External Fan Fault	X			14-53
25	Brake resistor short-circuited	X			
26	Brake resistor power limit	(X)	(X)		2-13
27	Brake chopper short-circuited	X	X		
28	Brake check	(X)	(X)		2-15
29	Drive over temperature	X	X	X	
30	Motor phase U missing	(X)	(X)	(X)	4-58
31	Motor phase V missing	(X)	(X)	(X)	4-58
32	Motor phase W missing	(X)	(X)	(X)	4-58
33	Inrush fault		X	X	
34	Fieldbus communication fault	X	X		
35	Out of frequency range	X	X		
36	Mains failure	X	X		
37	Phase Imbalance	X	X		
39	Heatsink sensor		X	X	
40	Overload of Digital Output Terminal 27	(X)			5-00, 5-01
41	Overload of Digital Output Terminal 29	(X)			5-00, 5-02
42	Overload of Digital Output On X30/6	(X)			5-32
42	Overload of Digital Output On X30/7	(X)			5-33
46	Pwr. card supply		X	X	
47	24 V supply low	X	X	X	
48	1.8 V supply low		X	X	
49	Speed limit	X			
50	AMA calibration failed		X		
51	AMA check U_{nom} and I_{nom}		X		
52	AMA low I_{nom}		X		
53	AMA motor too big		X		
54	AMA motor too small		X		
55	AMA parameter out of range		X		
56	AMA interrupted by user		X		
57	AMA timeout		X		
58	AMA internal fault	X	X		
59	Current limit	X			
60	External Interlock	X			
62	Output Frequency at Maximum Limit	X			
64	Voltage Limit	X			
65	Control Board Over-temperature	X	X	X	
66	Heat sink Temperature Low	X			
67	Option Configuration has Changed		X		
68	Safe Stop Activated		X ¹⁾		
69	Pwr. Card Temp		X	X	
70	Illegal FC configuration			X	
71	PTC 1 Safe Stop	X	X ¹⁾		
72	Dangerous Failure			X ¹⁾	
73	Safe Stop Auto Restart				
76	Power Unit Setup	X			
79	Illegal PS config		X	X	
80	Drive Initialised to Default Value		X		
91	Analog input 54 wrong settings			X	
92	NoFlow	X	X		22-2*
93	Dry Pump	X	X		22-2*
94	End of Curve	X	X		22-5*
95	Broken Belt	X	X		22-6*
96	Start Delayed	X			22-7*
97	Stop Delayed	X			22-7*
98	Clock Fault	X			0-7*

Table 9.1: Alarm/Warning code list

No.	Description	Warning	Alarm/Trip	Alarm/Trip Lock	Parameter Reference
220	Overload Trip		X		
243	Brake IGBT	X	X		
244	Heatsink temp	X	X	X	
245	Heatsink sensor		X	X	
246	Pwr.card supply		X	X	
247	Pwr.card temp		X	X	
248	Illegal PS config		X	X	
250	New spare part			X	
251	New Type Code		X	X	

Table 9.2: Alarm/Warning code list

(X) Dependent on parameter

1) Can not be Auto reset via par. 14-20 *Reset Mode*

A trip is the action when an alarm has appeared. The trip will coast the motor and can be reset by pressing the reset button or make a reset by a digital input (Par. 5-1* [1]). The origin event that caused an alarm cannot damage the frequency converter or cause dangerous conditions. A trip lock is an action when an alarm occurs, which may cause damage to frequency converter or connected parts. A Trip Lock situation can only be reset by a power cycling.

LED indication	
Warning	yellow
Alarm	flashing red
Trip locked	yellow and red

Alarm Word and Extended Status Word					
Bit	Hex	Dec	Alarm Word	Warning Word	Extended Status Word
0	00000001	1	Brake Check	Brake Check	Ramping
1	00000002	2	Pwr. Card Temp	Pwr. Card Temp	AMA Running
2	00000004	4	Earth Fault	Earth Fault	Start CW/CCW
3	00000008	8	Ctrl.Card Temp	Ctrl.Card Temp	Slow Down
4	00000010	16	Ctrl. Word TO	Ctrl. Word TO	Catch Up
5	00000020	32	Over Current	Over Current	Feedback High
6	00000040	64	Torque Limit	Torque Limit	Feedback Low
7	00000080	128	Motor Th Over	Motor Th Over	Output Current High
8	00000100	256	Motor ETR Over	Motor ETR Over	Output Current Low
9	00000200	512	Inverter Overld.	Inverter Overld.	Output Freq High
10	00000400	1024	DC under Volt	DC under Volt	Output Freq Low
11	00000800	2048	DC over Volt	DC over Volt	Brake Check OK
12	00001000	4096	Short Circuit	DC Voltage Low	Braking Max
13	00002000	8192	Inrush Fault	DC Voltage High	Braking
14	00004000	16384	Mains ph. Loss	Mains ph. Loss	Out of Speed Range
15	00008000	32768	AMA Not OK	No Motor	OVC Active
16	00010000	65536	Live Zero Error	Live Zero Error	
17	00020000	131072	Internal Fault	10V Low	
18	00040000	262144	Brake Overload	Brake Overload	
19	00080000	524288	U phase Loss	Brake Resistor	
20	00100000	1048576	V phase Loss	Brake IGBT	
21	00200000	2097152	W phase Loss	Speed Limit	
22	00400000	4194304	Fieldbus Fault	Fieldbus Fault	
23	00800000	8388608	24 V Supply Low	24V Supply Low	
24	01000000	16777216	Mains Failure	Mains Failure	
25	02000000	33554432	1.8V Supply Low	Current Limit	
26	04000000	67108864	Brake Resistor	Low Temp	
27	08000000	134217728	Brake IGBT	Voltage Limit	
28	10000000	268435456	Option Change	Unused	
29	20000000	536870912	Drive Initialised	Unused	
30	40000000	1073741824	Safe Stop	Unused	

Table 9.3: Description of Alarm Word, Warning Word and Extended Status Word

The alarm words, warning words and extended status words can be read out via serial bus or optional fieldbus for diagnosis. See also par. 16-90 *Alarm Word*, par. 16-92 *Warning Word* and par. 16-94 *Ext. Status Word*.

9.1.1 Fault Messages

WARNING 1, 10 Volts low:

The 10 V voltage from terminal 50 on the control card is below 10 V. Remove some of the load from terminal 50, as the 10 V supply is overloaded. Max. 15 mA or minimum 590 Ω.

WARNING/ALARM 2, Live zero error:

The signal on terminal 53 or 54 is less than 50% of the value set in par. 6-10 *Terminal 53 Low Voltage*, par. 6-12 *Terminal 53 Low Current*, par. 6-20 *Terminal 54 Low Voltage*, or par. 6-22 *Terminal 54 Low Current* respectively.

WARNING/ALARM 3, No motor:

No motor has been connected to the output of the frequency converter.

WARNING/ALARM 4, Mains phase loss:

A phase is missing on the supply side, or the mains voltage imbalance is too high.

This message also appears in case of a fault in the input rectifier on the frequency converter.

Check the supply voltage and supply currents to the frequency converter.

WARNING 5, DC link voltage high:

The intermediate circuit voltage (DC) is higher than the over-voltage limit of the control system. The frequency converter is still active.

WARNING 6, DC link voltage low:

The intermediate circuit voltage (DC) is below the undervoltage limit of the control system. The frequency converter is still active.

WARNING/ALARM 7, DC over voltage:

If the intermediate circuit voltage exceeds the limit, the frequency converter trips after a time.

Possible corrections:

Select **Over Voltage Control** function in par. 2-17 *Over-voltage Control*

Connect a brake resistor

Extend the ramp time

Activate functions in par. 2-10 *Brake Function*

Increase par. 14-26 *Trip Delay at Inverter Fault*

Selecting OVC function will extend the ramp times.

Alarm/warning limits:			
Voltage Range	3 x 200-240 VAC [VDC]	3 x 380-500 VAC [VDC]	3 x 550-600 VAC [VDC]
Under voltage	185	373	532
Voltage warning low	205	410	585
Voltage warning high (w/o brake - w/ brake)	390/405	810/840	943/965
Over voltage	410	855	975

The voltages stated are the intermediate circuit voltage of the frequency converter with a tolerance of ± 5 %. The corresponding mains voltage is the intermediate circuit voltage (DC-link) divided by 1.35

WARNING/ALARM 8, DC under voltage:

If the intermediate circuit voltage (DC) drops below the "voltage warning low" limit (see table above), the frequency converter checks if 24 V backup supply is connected.

If no 24 V backup supply is connected, the frequency converter trips after a given time depending on the unit.

To check whether the supply voltage matches the frequency converter, see 3.1 *General Specifications*.

WARNING/ALARM 9, Inverter overloaded:

The frequency converter is about to cut out because of an overload (too high current for too long). The counter for electronic, thermal inverter protection gives a warning at 98% and trips at 100%, while giving an alarm. You cannot reset the frequency converter until the counter is below 90%.

The fault is that the frequency converter is overloaded by more than nominal current for too long.

WARNING/ALARM 10, Motor ETR over temperature:

According to the electronic thermal protection (ETR), the motor is too hot. You can choose if you want the frequency converter to give a warning or an alarm when the counter reaches 100% in par. 1-90 *Motor Thermal Protection*. The fault is that the motor is overloaded by more than nominal current for too long. Check that the motor par. 1-24 *Motor Current* is set correctly.

WARNING/ALARM 11, Motor thermistor over temp:

The thermistor or the thermistor connection is disconnected. You can choose if you want the frequency converter to give a warning or an alarm in par. 1-90 *Motor Thermal Protection*. Check that the thermistor is connected correctly between terminal 53 or 54 (analog voltage input) and terminal 50 (+ 10 Volts supply), or between terminal 18 or 19 (digital input PNP only) and terminal 50. If a KTY sensor is used, check for correct connection between terminal 54 and 55.

WARNING/ALARM 12, Torque limit:

The torque is higher than the value in par. 4-16 *Torque Limit Motor Mode* (in motor operation) or the torque is higher than the value in par. 4-17 *Torque Limit Generator Mode* (in regenerative operation).

WARNING/ALARM 13, Over Current:

The inverter peak current limit (approx. 200% of the rated current) is exceeded. The warning will last approx. 8-12 sec., then the frequency converter trips and issues an alarm. Turn off the frequency converter and check if the motor shaft can be turned and if the motor size matches the frequency converter.

ALARM 14, Earth fault:

There is a discharge from the output phases to earth, either in the cable between the frequency converter and the motor or in the motor itself. Turn off the frequency converter and remove the earth fault.

ALARM 15, In-complete hardware:

A fitted option is not handled by the present control board (hardware or software).

ALARM 16, Short-circuit:

There is short-circuiting in the motor or on the motor terminals.
Turn off the frequency converter and remove the short-circuit.

WARNING/ALARM 17, Control word timeout:

There is no communication to the frequency converter.

The warning will only be active when par. 8-04 *Control Timeout Function* is NOT set to *OFF*.

If par. 8-04 *Control Timeout Function* is set to *Stop* and *Trip*, a warning appears and the frequency converter ramps down to zero speed, while giving an alarm.

par. 8-03 *Control Timeout Time* could possibly be increased.

WARNING 23, Internal fans:

External fans have failed due to defect hardware or fans not mounted.

WARNING 24, External fan fault:

The fan warning function is an extra protection function that checks if the fan is running / mounted. The fan warning can be disabled in par. 14-53 *Fan Monitor*, [0] Disabled.

WARNING 25, Brake resistor short-circuited:

The brake resistor is monitored during operation. If it short-circuits, the brake function is disconnected and the warning appears. The frequency converter still works, but without the brake function. Turn off the frequency converter and replace the brake resistor (see par. 2-15 *Brake Check*).

ALARM/WARNING 26, Brake resistor power limit:

The power transmitted to the brake resistor is calculated as a percentage, as a mean value over the last 120 s, on the basis of the resistance value of the brake resistor (par. 2-11 *Brake Resistor (ohm)*) and the intermediate circuit voltage. The warning is active when the dissipated braking power is higher than 90%. If *Trip*[2] has been selected in par. 2-13 *Brake Power Monitoring*, the frequency converter cuts out and issues this alarm, when the dissipated braking power is higher than 100%.

WARNING/ALARM 27, Brake chopper fault:

The brake transistor is monitored during operation and if it short-circuits, the brake function disconnects and the warning comes up. The frequency converter is still able to run, but since the brake transistor has short-circuited, substantial power is transmitted to the brake resistor, even if it is inactive.

Turn off the frequency converter and remove the brake resistor.



Warning: There is a risk of substantial power being transmitted to the brake resistor if the brake transistor is short-circuited.

ALARM/WARNING 28, Brake check failed:

Brake resistor fault: the brake resistor is not connected/working.

WARNING/ALARM 29, Drive over temperature:

If the enclosure is IP00 or IP20/Nema1 the cut-out temperature of the heat-sink is 90 °C. If IP54 is used, the cut-out temperature is 80 °C.

The fault could be:

- Ambient temperature too high
- Too long motor cable

ALARM 30, Motor phase U missing:

Motor phase U between the frequency converter and the motor is missing.

Turn off the frequency converter and check motor phase U.

ALARM 31, Motor phase V missing:

Motor phase V between the frequency converter and the motor is missing.
Turn off the frequency converter and check motor phase V.

ALARM 32, Motor phase W missing:

Motor phase W between the frequency converter and the motor is missing.

Turn off the frequency converter and check motor phase W.

ALARM 33, Inrush fault:

Too many powerups have occurred within a short time period. See the chapter *General Specifications* for the allowed number of power-ups within one minute.

WARNING/ALARM 34, Fieldbus communication fault:

The fieldbus on the communication option card is not working.

WARNING/ALARM 35, Option Fault:

Option fault. Please contact your supplier.

WARNING/ALARM 36, Mains failure:

This warning/alarm is only active if the supply voltage to the frequency converter is lost and parameter 14-10 is NOT set to OFF. Possible correction: check the fuses to the frequency converter

WARNING/ALARM 37, Phase Imbalance:

There is a current imbalance between the power units.

ALARM 39, Heatsink Sensor:

No feedback from the heatsink sensor.

WARNING 40, Overload of Digital Output Terminal 27

Check the load connected to terminal 27 or remove short-circuit connection. Check parameters 5-00 and 5-01.

WARNING 41, Overload of Digital Output Terminal 29:

Check the load connected to terminal 29 or remove short-circuit connection. Check parameters 5-00 and 5-02.

WARNING 42, Overload of Digital Output On X30/6 :

Check the load connected to X30/6 or remove short-circuit connection. Check parameter 5-32.

WARNING 42, Overload of Digital Output On X30/7 :

Check the load connected to X30/7 or remove short-circuit connection. Check parameter 5-33.

ALARM 46, Pwr. card supply:

The supply on the power card is out of range.

WARNING 47, 24 V supply low:

The external 24 V DC backup power supply may be overloaded, otherwise contact your supplier.

ALARM 48, 1.8 V supply low:

Contact your supplier.

WARNING 49, Speed limit:

The speed has been limited by range in par. 4-11 *Motor Speed Low Limit [RPM]* and par. 4-13 *Motor Speed High Limit [RPM]*.

ALARM 50, AMA calibration failed:

Contact your supplier.

ALARM 51, AMA check Unom and Inom:

The setting of motor voltage, motor current, and motor power is presumably wrong. Check the settings.

ALARM 52, AMA low Inom:

The motor current is too low. Check the settings.

ALARM 53, AMA motor too big:

The motor is too big for the AMA to be carried out.

ALARM 54, AMA motor too small:

The motor is too small for the AMA to be carried out.

ALARM 55, AMA par. out of range:

The par. values found from the motor are outside acceptable range.

ALARM 56, AMA interrupted by user:

The AMA has been interrupted by the user.

ALARM 57, AMA timeout:

Try to start the AMA again a number of times, until the AMA is carried out. Please note that repeated runs may heat the motor to a level where the resistance R_s and R_r are increased. In most cases, however, this is not critical.

WARNING/ALARM 58, AMA internal fault:

Contact your supplier.

WARNING 59, Current limit:

The current is higher than the value in par. 4-18 *Current Limit*.

WARNING 60, External Interlock:

External Interlock has been activated. To resume normal operation, apply 24 VDC to the terminal programmed for External Interlock and reset the frequency converter (via Bus, Digital I/O or by pressing [Reset]).

WARNING 62, Output Frequency at Maximum Limit:

The output frequency is limited by the value set in par. 4-19 *Max Output Frequency*

WARNING/ALARM/TRIP 65, Control Card Over Temperature:

Control card over temperature: The cut-out temperature of the control card is 80° C.

WARNING 66, Low Temp.:

The heat sink temperature is measured to be low. This could indicate that the temperature sensor is defective and thus the fan speed is increased to the maximum in case the power part or control card is very hot.

ALARM 67, Option Configuration has Changed:

One or more options has either been added or removed since the last power-down.

ALARM 68, Safe Stop:

Safe Stop has been activated. To resume normal operation, apply 24 VDC to terminal 37 then send a Reset signal (via Bus, Digital I/O or by pressing [Reset]).

ALARM 69, Pwr. Card Temp:

Power card over temperature.

WARNING 76, Power Unit Setup:

The required number of power units does not match the detected number of active power units.

ALARM 70, Illegal Frequency Converter Configuration:

Actual combination of control board and power board is illegal.

ALARM 90, Feedback Mon.:**ALARM 92, NoFlow:**

A no load situation has been detected for the system. See parameter group 22-2*.

ALARM 93, Dry Pump:

A no flow situation and high speed indicates that the pump has run dry. See parameter group 22-2*

ALARM 94, End of Curve:

Feed back stays lower than the set point, which may be indicates a leakage in the pipe system. See parameter group 22-5*

ALARM 95, Broken Belt:

Torque is below the torque level set for no load indicating a broken belt. See parameter group 22-6*

ALARM 96, Start Delayed:

Start of the motor has been delayed due to short cycle protection is active. See parameter group 22-7*.

ALARM 220, Overload Trip:

Motor overload has tripped. Indicates excess motor load. Check motor and driven load. To reset press the "Off Reset" key. Then, to restart the system, press the "Auto On" or "Hand On" key.

WARNING/ALARM 243, Brake IGBT:

The brake transistor is short-circuited or the brake function is disconnected. Turn off the frequency converter as a fire precaution. Report value indicates source of alarm (from left): 1-4 Inverter 5-8 Rectifier.

WARNING/ALARM 244, Heatsink Temp:

Drive heatsink over temperature: Report value indicates source of alarm (from left): 1-4 Inverter 5-8 Rectifier.

ALARM 245, Heatsink Sensor:

No feedback from the heatsink sensor Report value indicates source of alarm (from left): 1-4 Inverter 5-8 Rectifier.

ALARM 246, Pwr. Card Supply:

The supply on the power card is out of range Report value indicates source of alarm (from left): 1-4 Inverter 5-8 Rectifier.

ALARM 247, Pwr. Card Temp:

Power card over temperature Report value indicates source of alarm (from left): 1-4 Inverter 5-8 Rectifier.

ALARM 248, Illegal PS Config:

Power size configuration fault on the power card Report value indicates source of alarm (from left): 1-4 Inverter 5-8 Rectifier.

ALARM 250, New Spare Part:

The power or Switch Mode Power Supply has been exchanged. The frequency converter type code must be restored in the EEPROM. Select the correct type code in Par 14-23 according to the label on unit. Remember to select 'Save to EEPROM' to complete.

ALARM 251, New Type Code:

The frequency converter has got a new type code.

10 Specifications

10.1.1.1 Mains Supply 1 x 200 - 240 VAC

Mains Supply 1 x 200 - 240 VAC - Normal overload 110% for 1 minute

Frequency converter Typical Shaft Output [kW]	P1K1	P1K5	P2K2	P3K0	P3K7	P5K5	P7K5	P15K	P22K
Typical Shaft Output [HP] at 240 V	1.1	1.5	2.2	3.0	3.7	5.5	7.5	15	22
IP 20 / Chassis	A3	2.0	2.9	4.0	4.9	7.5	10	20	30
IP 21 / NEMA 1	-	B1	B1	B1	B1	B1	B2	C1	C2
IP 55 / NEMA 12	A5	B1	B1	B1	B1	B1	B2	C1	C2
IP 66	A5	B1	B1	B1	B1	B1	B2	C1	C2
Output current									
Continuous (3 x 200-240 V) [A]	6.6	7.5	10.6	12.5	16.7	24.2	30.8	59.4	88
Intermittent (3 x 200-240 V) [A]	7.3	8.3	11.7	13.8	18.4	26.6	33.4	65.3	96.8
Continuous kVA (208 V AC) [kVA]						5.00	6.40	12.27	18.30
Max. cable size: (mains, motor, brake) [[mm ² / AWG] ²⁾			0.2-4 / 4-10			10/7	35/2	50/1/0	95/4/0
Max. input current									
Continuous (1 x 200-240 V) [A]	12.5	15	20.5	24	32	46	59	111	172
Intermittent (1 x 200-240 V) [A]	13.8	16.5	22.6	26.4	35.2	50.6	64.9	122.1	189.2
Max. pre-fuses ¹⁾ [A]	20	30	40	40	60	80	100	150	200
Environment									
Estimated power loss at rated max. load [W] ⁴⁾	44	30	44	60	74	110	150	300	440
Weight enclosure IP 20 [kg]	4.9	-	-	-	-	-	-	-	-
Weight enclosure IP 21 [kg]	-	23	23	23	23	23	27	45	65
Weight enclosure IP 55 [kg]	-	23	23	23	23	23	27	45	65
Weight enclosure IP 66 [kg]	-	23	23	23	23	23	27	45	65
Efficiency ³⁾	0.968	0.98	0.98	0.98	0.98	0.98	0.98	0.98	0.98

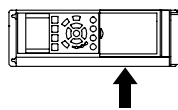
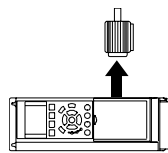

10.1.1.2 Mains Supply 3 x 200 - 240 VAC

Normal overload 110% for 1 minute

IP 20 / NEMA Chassis	A2	A2	A2	A2	A2	A2	A2	A2	A2	A2	A2	A2	A3	A3
IP 21 / NEMA 1	A2	A2	A2	A2	A2	A2	A2	A2	A2	A2	A2	A2	A3	A3
IP 55 / NEMA 12	A5	A5	A5	A5	A5	A5	A5	A5	A5	A5	A5	A5	A5	A5
IP 66	A5	A5	A5	A5	A5	A5	A5	A5	A5	A5	A5	A5	A5	A5

Mains supply 200 - 240 VAC

Frequency converter	PK25	PK37	PK55	PK75	P1K1	P1K5	P2K2	P3K0	P3K7
Typical Shaft Output [kW]	0.25	0.37	0.55	0.75	1.1	1.5	2.2	3	3.7
Typical Shaft Output [HP] at 208 V	0.25	0.37	0.55	0.75	1.5	2.0	2.9	4.0	4.9

Output current

Continuous (3 x 200-240 V) [A]	1.8	2.4	3.5	4.6	6.6	7.5	10.6	12.5	16.7
Intermittent (3 x 200-240 V) [A]	1.98	2.64	3.85	5.06	7.26	8.3	11.7	13.8	18.4
Continuous kVA (208 V AC) [kVA]	0.65	0.86	1.26	1.66	2.38	2.70	3.82	4.50	6.00
Max. cable size: (mains, motor, brake) [mm ² /AWG] ²	0.2 - 4 mm ² / 4 - 10 AWG								

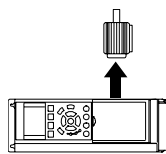

Max. input current

Continuous (3 x 200-240 V) [A]	1.6	2.2	3.2	4.1	5.9	6.8	9.5	11.3	15.0
Intermittent (3 x 200-240 V) [A]	1.7	2.42	3.52	4.51	6.5	7.5	10.5	12.4	16.5
Max. pre-fuses ¹⁾ [A]	10	10	10	10	20	20	20	32	32
Environment									
Estimated power loss at rated max. load [W] ⁴⁾	21	29	42	54	63	82	116	155	185
Weight enclosure IP20 [kg]	4.9	4.9	4.9	4.9	4.9	4.9	4.9	6.6	6.6
Weight enclosure IP21 [kg]	5.5	5.5	5.5	5.5	5.5	5.5	5.5	7.5	7.5
Weight enclosure IP55 [kg]	13.5	13.5	13.5	13.5	13.5	13.5	13.5	13.5	13.5
Weight enclosure IP 66 [kg]	13.5	13.5	13.5	13.5	13.5	13.5	13.5	13.5	13.5
Efficiency ³⁾	0.94	0.94	0.95	0.95	0.96	0.96	0.96	0.96	0.96

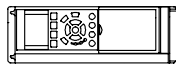

Mains supply 3 x 200 - 240 VAC - Normal overload 110% for 1 minute

IP 20 / NEMA Chassis (B3+4 and C3+4 may be converted to IP21 using a conversion kit (Please contact Danfoss))

IP 21 / NEMA 1
IP 55 / NEMA 12
IP 66

Frequency converter
Typical Shaft Output [kW]
Typical Shaft Output [HP] at 208 V

Output current

Continuous (3 x 200-240 V) [A]	B3	B3	B3	B4	B4	B4	B3	B3	B3	B3	C3	C3	C4	C4				
Intermittent (3 x 200-240 V) [A]	24.2	30.8	46.2	59.4	74.8	88.0	115	143	170	26.6	33.9	50.8	65.3	82.3	96.8	127	157	187
Continuous kVA (208 V AC) [kVA]	8.7	11.1	16.6	21.4	26.9	31.7	41.4	51.5	61.2									
Max. cable size: (mains, motor, brake) [mm ² / AWG] ²⁾	10/7			35/2			50/1/0			95/4/0			120/250 MCM					

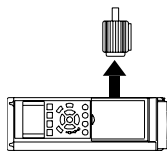

Max. input current

Continuous (3 x 200-240 V) [A]	22.0	28.0	42.0	54.0	68.0	80.0	104.0	130.0	154.0
Intermittent (3 x 200-240 V) [A]	24.2	30.8	46.2	59.4	74.8	88.0	114.0	143.0	169.0
Max. pre-fuses ¹⁾ [A]	63	63	63	80	125	125	160	200	250
Environment: Estimated power loss at rated max. load [W] ⁴⁾	269	310	447	602	737	845	1140	1353	1636
Weight enclosure IP20 [kg]	12	12	12	23.5	23.5	35	35	50	50
Weight enclosure IP21 [kg]	23	23	23	27	45	45	65	65	65
Weight enclosure IP55 [kg]	23	23	23	27	45	45	65	65	65
Weight enclosure IP 66 [kg]	23	23	23	27	45	45	65	65	65
Efficiency ³⁾	0.96	0.96	0.96	0.96	0.96	0.97	0.97	0.97	0.97

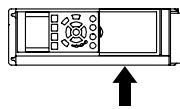

10.1.1.3 Mains Supply 1 x 380 - 480 VAC

Mains Supply 1x 380 VAC - Normal overload 110% for 1 minute

Frequency converter

Typical Shaft Output [kW]

Typical Shaft Output [HP] at 460 V

IP 21 / NEMA 1

IP 55 / NEMA 12

IP 66

Output current

	P7K5	P11K	P18K	P37K
Continuous (3 x 380-440 V) [A]	16	24	37.5	73
Intermittent (3 x 380-440 V) [A]	17.6	26.4	41.2	80.3
Continuous (3 x 441-480 V) [A]	14.5	21	34	65
Intermittent (3 x 441-480 V) [A]	15.4	23.1	37.4	71.5
Continuous kVA (400 V AC) [kVA]	11.0	16.6	26	50.6
Continuous kVA (460 V AC) [kVA]	11.6	16.7	27.1	51.8
Max. cable size: (mains, motor, brake) [[mm ² / AWG] 2]	10/7	35/2	50/1/0	120/4/0

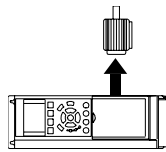

Max. input current

Continuous (1 x 380-440 V) [A]	33	48	78	151
Intermittent (1 x 380-440 V) [A]	36	53	85.8	166
Continuous (1 x 441-480 V) [A]	30	41	72	135
Intermittent (1 x 441-480 V) [A]	33	46	79.2	148
Max. pre-fuses ¹⁾ [A]	63	80	160	250
Environment				
Estimated power loss at rated max. load [W] ⁴⁾	300	440	740	1480
Weight enclosure IP 21 [kg]	23	27	45	65
Weight enclosure IP 55 [kg]	23	27	45	65
Weight enclosure IP 66 [kg]	23	27	45	65
Efficiency ³⁾	0.96	0.96	0.96	0.96

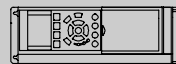

10.1.1.4 Mains Supply 3 x 380 - 480 VAC

Mains Supply 3 x 380 - 480 VAC - Normal overload 110% for 1 minute

Frequency converter	PK37	PK55	PK75	PK1K1	PK1K5	P2K2	P3K0	P4K0	PK5	P7K5
Typical Shaft Output [kW]	0.37	0.55	0.75	1.1	1.5	2.2	3	4	5.5	7.5
Typical Shaft Output [HP] at 460 V	0.5	0.75	1.0	1.5	2.0	2.9	4.0	5.3	7.5	10
IP 20 / NEMA Chassis	A2	A2	A2	A2	A2	A2	A2	A2	A3	A3
IP 21 / NEMA 1										
IP 55 / NEMA 12	A5	A5	A5	A5	A5	A5	A5	A5	A5	A5
IP 66	A5	A5	A5	A5	A5	A5	A5	A5	AA	A5
Output current										
Continuous (3 x 380-440 V) [A]	1.3	1.8	2.4	3	4.1	5.6	7.2	10	13	16
Intermittent (3 x 380-440 V) [A]	1.43	1.98	2.64	3.3	4.5	6.2	7.9	11	14.3	17.6
Continuous (3 x 441-480 V) [A]	1.2	1.6	2.1	2.7	3.4	4.8	6.3	8.2	11	14.5
Intermittent (3 x 441-480 V) [A]	1.32	1.76	2.31	3.0	3.7	5.3	6.9	9.0	12.1	15.4
Continuous kVA (400 V AC) [kVA]	0.9	1.3	1.7	2.1	2.8	3.9	5.0	6.9	9.0	11.0
Continuous kVA (460 V AC) [kVA]	0.9	1.3	1.7	2.4	2.7	3.8	5.0	6.5	8.8	11.6
Max. cable size: (mains, motor, brake) [mm ² / AWG] ²⁾	4/10									

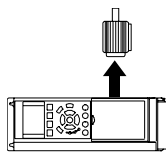

Max. input current

Continuous (3 x 380-440 V) [A]	1.2	1.6	2.2	2.7	3.7	5.0	6.5	9.0	11.7	14.4
Intermittent (3 x 380-440 V) [A]	1.32	1.76	2.42	3.0	4.1	5.5	7.2	9.9	12.9	15.8
Continuous (3 x 441-480 V) [A]	1.0	1.4	1.9	2.7	3.1	4.3	5.7	7.4	9.9	13.0
Intermittent (3 x 441-480 V) [A]	1.1	1.54	2.09	3.0	3.4	4.7	6.3	8.1	10.9	14.3
Max. pre-fuses ¹⁾ [A]	10	10	10	10	10	20	20	20	30	30
Environment										
Estimated power loss at rated max. load [W] ⁴⁾	35	42	46	58	62	88	116	124	187	255
Weight enclosure IP20 [kg]	4.7	4.7	4.8	4.8	4.9	4.9	4.9	4.9	6.6	6.6
Weight enclosure IP 21 [kg]	13.5	13.5	13.5	13.5	13.5	13.5	13.5	13.5	14.2	14.2
Weight enclosure IP 55 [kg]	13.5	13.5	13.5	13.5	13.5	13.5	13.5	13.5	14.2	14.2
Weight enclosure IP 66 [kg]	0.93	0.95	0.96	0.96	0.97	0.97	0.97	0.97	0.97	0.97
Efficiency ³⁾										

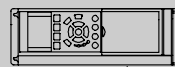

Mains Supply 3 x 380 - 480 VAC - Normal overload 110% for 1 minute										
Frequency converter Typical Shaft Output [kW]	P11K	P15K	P18K	P22K	P30K	P37K	P45K	P55K	P75K	P90K
Typical Shaft Output [HP] at 460 V	1.5	2.0	2.5	3.0	4.0	5.0	6.0	7.5	10.0	12.5
IP 20 / NEMA Chassis (B3+4 and C3+4 may be converted to IP21 using a conversion kit (Please contact Danfoss))	B3	B3	B3	B4	B4	B4	C3	C3	C4	C4
IP 21 / NEMA 1	B1	B1	B1	B2	B2	C1	C1	C1	C2	C2
IP 55 / NEMA 12	B1	B1	B1	B2	B2	C1	C1	C1	C2	C2
IP 66	B1	B1	B1	B2	B2	C1	C1	C1	C2	C2
Output current										
Continuous (3 x 380-440 V) [A]	24	32	37.5	44	61	73	90	106	147	177
Intermittent (3 x 380-440 V) [A]	26.4	35.2	41.3	48.4	67.1	80.3	99	117	162	195
Continuous (3 x 441-480 V) [A]	21	27	34	40	52	65	80	105	130	160
Intermittent (3 x 441-480 V) [A]	23.1	29.7	37.4	44	61.6	71.5	88	116	143	176
Continuous kVA (400 V AC) [kVA]	16.6	22.2	26	30.5	42.3	50.6	62.4	73.4	102	123
Continuous kVA (460 V AC) [kVA]	16.7	21.5	27.1	31.9	41.4	51.8	63.7	83.7	104	128
Max. cable size: (mains, motor, brake) [[mm ² / AWG] ²⁾	10/7			35/2			50/1/0		120/4/0	120/4/0
Max. input current										
Continuous (3 x 380-440 V) [A]	22	29	34	40	55	66	82	96	133	161
Intermittent (3 x 380-440 V) [A]	24.2	31.9	37.4	44	60.5	72.6	90.2	106	146	177
Continuous (3 x 441-480 V) [A]	19	25	31	36	47	59	73	95	118	145
Intermittent (3 x 441-480 V) [A]	20.9	27.5	34.1	39.6	51.7	64.9	80.3	105	130	160
Max. pre-fuses ¹⁾ [A]	63	63	63	63	80	100	125	160	250	250
Environment										
Estimated power loss at rated max. load [W] ⁴⁾	278	392	465	525	698	739	843	1083	1384	1474
Weight enclosure IP 20 [kg]	12	12	12	23.5	23.5	23.5	35	35	50	50
Weight enclosure IP 21 [kg]	23	23	23	27	27	45	45	45	65	65
Weight enclosure IP 55 [kg]	23	23	23	27	27	45	45	45	65	65
Weight enclosure IP 66 [kg]	23	23	23	27	27	45	45	45	65	65
Efficiency ³⁾	0.98	0.98	0.98	0.98	0.98	0.98	0.98	0.98	0.98	0.99

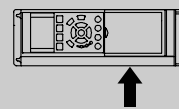
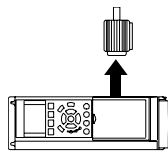

Normal overload 110% for 1 minute

Frequency converter	P110	P132	P160	P200	P250	P315	P355	P400	P450	P500	P560	P630	P710	P800	P1M0
Typical Shaft Output [kW] at 400V	1.10	1.32	1.60	2.00	2.50	3.15	3.55	4.00	4.50	5.00	5.60	6.30	7.10	8.00	10.00
Typical Shaft Output [HP] at 460V	1.50	2.00	2.50	3.00	3.50	4.50	5.00	6.00	7.00	7.50	8.00	9.00	10.00	12.00	13.50
IP 00	D3	D3	D4	D4	D4	E2	E2	E2	E2	F1/F3	F1/F3	F1/F3	F1/F3	F2/F4	F2/F4
IP 21 / Nema 1	D1	D1	D2	D2	D2	E1	E1	E1	E1	F1/F3	F1/F3	F1/F3	F1/F3	F2/F4	F2/F4
IP 54 / Nema 12	D1	D1	D2	D2	D2	E1	E1	E1	E1	F1/F3	F1/F3	F1/F3	F1/F3	F2/F4	F2/F4

Output current

Continuous (3 x 380-440 V) [A]	212	260	315	395	480	600	658	745	800	880	990	1120	1260	1460	1720
Intermittent (3 x 380-440 V) [A]	233	286	347	435	528	660	724	820	880	968	1089	1232	1386	1606	1892
Continuous (3 x 441-480V) [A]	190	240	302	361	443	540	590	678	730	780	890	1050	1160	1380	1530
Intermittent (3 x 441-480V) [A]	209	264	332	397	487	594	649	746	803	858	979	1155	1276	1518	1683
Continuous kVA (400 VAC) [kVA]	147	180	218	274	333	416	456	516	554	610	686	776	873	1012	1192
Continuous kVA (460 VAC) [kVA]	151	191	241	288	353	430	470	540	582	621	709	837	924	1100	1219

Max. cable size:

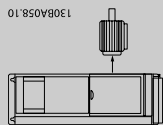

(motor,) [mm ² / AWG ²⁾]	2x70	2x2/0	2x185	2x300 mcm	2x185	4x240	4x500 mcm	8x150	8x300 mcm	12x150	12x300 mcm
(mains,) [mm ² / AWG ²⁾]	2x70	2x2/0	2x185	2x300 mcm	2x185	4x240	4x500 mcm	8x150	8x300 mcm	12x150	12x300 mcm
(loadsharing) [mm ² / AWG ²⁾]	2x70	2x2/0	2x185	2x300 mcm	2x185	4x240	4x500 mcm	8x150	8x300 mcm	12x150	12x300 mcm
(brake) [mm ² / AWG ²⁾]	2x70	2x2/0	2x185	2x300 mcm	2x185	4x240	4x500 mcm	8x150	8x300 mcm	12x150	12x300 mcm

Max. input current

Continuous (3 x 380-440 V) [A]	204	251	304	381	463	590	647	733	787	857	964	1090	1227	1422	1675
Continuous (3 x 441-480V) [A]	183	231	291	348	427	531	580	667	718	759	867	1022	1129	1344	1490
Max. pre-fuses ¹⁾ [A]	300	350	400	500	630	700	900	900	900	1600	1600	2000	2000	2500	2500

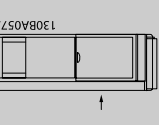

Environment:	3234	3782	4213	5119	5893	6790	7701	8879	9670	10647	12338	13201	15436	18084	20358
Estimated power loss at 400 VAC at rated max. load [W] ⁴⁾	2947	3665	4063	4652	5634	6082	6953	8089	8803	9414	11006	12353	14041	17137	17752
Estimated power loss at 460 VAC at rated max. load [W] ⁴⁾	82	91	112	123	138	221	234	236	277	-	-	-	-	-	-
Weight enclosure IP00 [kg]	96	104	125	136	151	263	270	272	313	1004	1004	1004	1004	1246	1246
Weight enclosure IP 21 [kg]	96	104	125	136	151	263	270	272	313	1299	1299	1299	1299	1541	1541
Weight enclosure IP 54 [kg]	0.98	0.98	0.98	0.98	0.98	0.98	0.98	0.98	0.98	0.98	0.98	0.98	0.98	0.98	0.98

¹⁾ For type of fuse see section *Fuses*
²⁾ American Wire Gauge
³⁾ Measured using 5 m screened motor cables at rated load and rated frequency
⁴⁾ The typical power loss is at normal load conditions and expected to be within +/- 15% (tolerance relates to variety in voltage and cable conditions). Values are based on a typical motor efficiency (eff2/eff3 border line). Lower efficiency motors will also add to the power loss in the frequency converter and vice versa. If the switching frequency is raised from nominal the power losses may rise significantly. and typical control card power consumptions are included. Further options and customer load may add up to 30 Watts to the losses. (Though typically only 4 Watts extra for a fully loaded control card or options for slot A or slot B, each).
 Although measurements are made with state of the art equipment, some measurement inaccuracy must be allowed for (+/- 5%).

10.1.5 Mains Supply 3 x 525 - 600 VAC

Normal overload 110% for 1 minute

Size:	PK75	PIK1	P1K5	P2K2	P3K0	P4K0	P5K5	P7K5	P11K	P15K	P18K	P22K	P30K	P37K	P45K	P55K	P75K	P90K
Typical Shaft Output [kW]	0.75	1.1	1.5	2.2	3	4	5.5	7.5	11	15	18.5	22	30	37	45	55	75	90
IP 20 / NEMA Chassis	A2	A2	A2	A2	A2	A2	A3	A3	B3	B3	B3	B4	B4	B4	C3	C3	C4	C4
IP 21 / NEMA 1	A2	A2	A2	A2	A2	A2	A3	A3	B1	B1	B1	B2	B2	B2	C1	C1	C2	C2
IP 55 / NEMA 12	A5	A5	A5	A5	A5	A5	A5	A5	B1	B1	B1	B2	B2	B2	C1	C1	C2	C2
IP 66	A5	A5	A5	A5	A5	A5	A5	A5	B1	B1	B1	B2	B2	B2	C1	C1	C2	C2
Output current																		
Continuous (3 x 525-550 V) [A]	1.8	2.6	2.9	4.1	5.2	6.4	9.5	11.5	19	23	28	36	43	54	65	87	105	137
Intermittent (3 x 525-550 V) [A]	2.9	3.2	3.2	4.5	5.7	7.0	10.5	12.7	21	25	31	40	47	59	72	96	116	151
Continuous (3 x 525-600 V) [A]	1.7	2.4	2.7	3.9	4.9	6.1	9.0	11.0	18	22	27	34	41	52	62	83	100	131
Intermittent (3 x 525-600 V) [A]	2.6	3.0	3.0	4.3	5.4	6.7	9.9	12.1	20	24	30	37	45	57	68	91	110	144
Continuous kVA (525 V AC) [kVA]	1.7	2.5	2.8	3.9	5.0	6.1	9.0	11.0	18.1	21.9	26.7	34.3	41	51.4	61.9	82.9	100	130.5
Continuous kVA (575 V AC) [kVA]	1.7	2.4	2.7	3.9	4.9	6.1	9.0	11.0	17.9	21.9	26.9	33.9	40.8	51.8	61.7	82.7	99.6	130.5
Max. cable size (mains, motor, brake) [AWG] 2) [mm ²]	24 - 10 AWG 0.2 - 4																	
Max. input current																		
Continuous (3 x 525-600 V) [A]	1.7	2.4	2.7	4.1	5.2	5.8	8.6	10.4	17.2	20.9	25.4	32.7	39	49	59	78.9	95.3	124.3
Intermittent (3 x 525-600 V) [A]	2.7	3.0	3.0	4.5	5.7	6.4	9.5	11.5	19	23	28	36	43	54	65	87	105	137
Max. pre-fuses ¹⁾ [A]	10	10	10	20	20	20	32	32	40	40	50	60	80	100	150	160	225	250
Environment:																		
Estimated power loss at rated max. load [W] ⁴⁾	35	50	65	92	122	145	195	261	225	285	329	460	560	740	860	890	1020	1130
Weight [kg]:																		
Enclosure IP20	6.5	6.5	6.5	6.5	6.5	6.5	6.6	6.6	12	12	12	23.5	23.5	23.5	35	35	50	50
Efficiency ⁴⁾	0.97	0.97	0.97	0.97	0.97	0.97	0.97	0.97	0.98	0.98	0.98	0.98	0.98	0.98	0.98	0.98	0.98	0.98

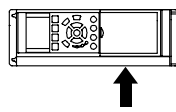
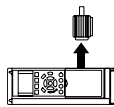

Table 10.1: ⁵⁾ Motor and mains cable: 300MCM/150mm²

10.1.6 Mains Supply 3 x 525 - 690 VAC

Normal overload 110% for 1 minute												
Size:	P11K	P15K	P18K	P22K	P30K	P37K	P45K	P55K	P75K	P90K		
Typical Shaft Output [kW]	11	15	18.5	22	30	37	45	55	75	90		
Typical Shaft Output [HP] at 575 V	10	16.4	20.1	24	33	40	50	60	75	100		
IP 21 / NEMA 1	B2	B2	B2	B2	B2	C2	C2	C2	C2	C2		
IP 55 / NEMA 12	B2	B2	B2	B2	B2	C2	C2	C2	C2	C2		
Output current												
Continuous (3 x 525-550 V) [A]	14	19	23	28	36	43	54	65	87	105		
Intermittent (3 x 525-550 V) [A]	15.4	20.9	25.3	30.8	39.6	47.3	59.4	71.5	95.7	115.5		
Continuous (3 x 551-690 V) [A]	13	18	22	27	34	41	52	62	83	100		
Intermittent (3 x 551-690 V) [A]	14.3	19.8	24.2	29.7	37.4	45.1	57.2	68.2	91.3	110		
Continuous kVA (550 V AC) [kVA]	13.3	18.1	21.9	26.7	34.3	41	51.4	61.9	82.9	100		
Continuous kVA (575 V AC) [kVA]	12.9	17.9	21.9	26.9	33.8	40.8	51.8	61.7	82.7	99.6		
Continuous kVA (690 V AC) [kVA]	15.5	21.5	26.3	32.3	40.6	49	62.1	74.1	99.2	119.5		
Max. cable size (mains, motor, brake) [mm ²]/[AWG] ²⁾											95	
											1/0	4/0
Max. input current												
Continuous (3 x 525-690 V) [A]	15	19.5	24	29	36	49	59	71	87	99		
Intermittent (3 x 525-690 V) [A]	16.5	21.5	26.4	31.9	39.6	53.9	64.9	78.1	95.7	108.9		
Max. pre-fuses ¹⁾ [A]	63	63	63	63	80	100	125	160	160	160		
Environment:												
Estimated power loss at rated max. load [W] ⁴⁾	201	285	335	375	430	592	720	880	1200	1440		
Weight:												
IP21 [kg]	27	27	27	27	27	65	65	65	65	65		
IP55 [kg]	27	27	27	27	27	65	65	65	65	65		
Efficiency ⁴⁾	0.98	0.98	0.98	0.98	0.98	0.98	0.98	0.98	0.98	0.98		

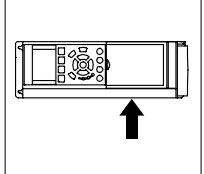
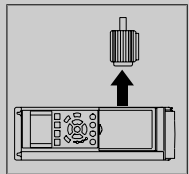
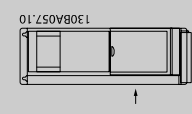
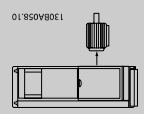

Table 10.2: ⁵⁾ Motor and mains cable: 300MCM/150mm²

10.1.7 Mains Supply 3 x 525 - 690 VAC

Normal overload 110% for 1 minute

Frequency converter	P45K	P55K	P75K	P90K	P110	P132	P160	P200	P250	P315	P400	P450	P500	P560	P630	P710	P800	P900	P1M0	P1M2
Typical Shaft Output [kW]	45	55	75	90	110	132	160	200	250	315	400	450	500	560	630	710	800	900	1000	1200
Typical Shaft Output [HP] at 575 V	50	60	75	100	125	150	200	250	300	350	400	450	500	600	650	750	950	1050	1150	1350
IP 00	D3	D3	D3	D3	D3	D3	D3	D4	D4	D4	D4	E2	E2	E2	E2	-	-	-	-	-
IP 21 / Nema 1	D1	D1	D1	D1	D1	D1	D1	D2	D2	D2	D2	E1	E1	E1	E1	F1/ F3 ⁶⁾	F1/ F3 ⁶⁾	F1/ F3 ⁶⁾	F2/ F4 ⁶⁾	F2/ F4 ⁶⁾
IP 54 / Nema 12	D1	D1	D1	D1	D1	D1	D1	D2	D2	D2	D2	E1	E1	E1	E1	F1/ F3 ⁶⁾	F1/ F3 ⁶⁾	F1/ F3 ⁶⁾	F1/ F3 ⁶⁾	F1/ F3 ⁶⁾
Output current																				
Continuous (3 x 550 V) [A]	56	76	90	113	137	162	201	253	303	360	418	470	523	596	630	763	889	988	1108	1317
Intermittent (3 x 550 V) [A]	62	84	99	124	151	178	221	278	333	396	460	517	575	656	693	839	978	1087	1219	1449
Continuous (3 x 690 V) [A]	54	73	86	108	131	155	192	242	290	344	400	450	500	570	630	730	850	945	1060	1260
Intermittent (3 x 690 V) [A]	59	80	95	119	144	171	211	266	319	378	440	495	550	627	693	803	935	1040	1166	1386
Continuous kVA (550 VAC) [kVA]	53	72	86	108	131	154	191	241	289	343	398	448	498	568	600	727	847	941	1056	1255
Continuous kVA (575 VAC) [kVA]	54	73	86	108	130	154	191	241	289	343	398	448	498	568	627	727	847	941	1056	1255
Continuous kVA (690 VAC) [kVA]	65	87	103	129	157	185	229	289	347	411	478	538	598	681	753	872	1016	1129	1267	1506
Max. cable size:																				
(Mains) [mm ² / AWG] ²⁾	2x70 2x2/0																			
(Motor) [mm ² / AWG] ²⁾	2x70																			
(Brake) [mm ² / AWG] ²⁾	2x70 2x2/0																			
Max. input current																				
Continuous (3 x 550 V) [A]	60	77	89	110	130	158	198	245	299	355	408	453	504	574	607	743	866	962	1079	1282
Continuous (3 x 575 V) [A]	58	74	85	106	124	151	189	224	286	339	390	434	482	549	607	711	828	920	1032	1227
Continuous (3 x 690 V) [A]	58	77	87	109	128	155	197	240	296	352	400	434	482	549	607	711	828	920	1032	1227
Max. mains pre-fuses ¹⁾ [A]	125	160	200	200	250	315	350	350	400	500	550	700	700	900	900	2000	2000	2000	2000	2000
Environment:																				
Estimated power loss at 690 VAC at rated max. load [W] ⁴⁾	1458	1717	1913	2262	2662	3430	3612	4292	5156	5821	6149	6440	7249	8727	9673	11315	1290	14533	1637	19207
Estimated power loss at 575 VAC at rated max. load [W] ⁴⁾	1398	1645	1827	2157	2533	2963	3430	4051	4867	5493	5852	6132	6903	8343	9244	10771	1227	13835	1559	18281
Weight enclosure IP00 [kg]	82	82	82	82	82	82	91	112	123	138	151	221	221	236	277	-	-	-	-	-
Weight enclosure IP 21 [kg] ⁶⁾	96	96	96	96	96	96	104	125	136	151	165	263	263	272	313	1004	1004	1004	1004	1246
Weight enclosure IP 54 [kg] ⁶⁾	96	96	96	96	96	96	104	125	136	151	165	263	263	272	313	1004	1004	1004	1004	1246
Efficiency ³⁾	0.97	0.97	0.98	0.98	0.98	0.98	0.98	0.98	0.98	0.98	0.98	0.98	0.98	0.98	0.98	0.98	0.98	0.98	0.98	0.98



¹⁾ For type of fuse see section *Fuses*
²⁾ American Wire Gauge
³⁾ Measured using 5 m screened motor cables at rated load and rated frequency
⁴⁾ The typical power loss is at normal load conditions and expected to be within +/- 15% (tolerance relates to variety in voltage and cable conditions). Values are based on a typical motor efficiency (eff2/eff3 border line). Lower efficiency motors will also add to the power loss in the frequency converter and vice versa.
 If the switching frequency is raised from nominal the power losses may rise significantly. and typical control card power consumptions are included. Further options and customer load may add up to 30 [W] to the losses. (Though typically only 4 [W] extra for a fully loaded control card, or options for slot A or slot B, each).
 Although measurements are made with state of the art equipment, some measurement inaccuracy must be allowed for (+/- 5%).
⁶⁾ Adding the F-enclosure option cabinet (resulting in the F3 and F4 enclosure sizes) adds 295 kg to the estimated weight.

Protection and Features:

- Electronic thermal motor protection against overload.
- Temperature monitoring of the heatsink ensures that the frequency converter trips if the temperature reaches $95\text{ °C} \pm 5\text{ °C}$. An overload temperature cannot be reset until the temperature of the heatsink is below $70\text{ °C} \pm 5\text{ °C}$ (Guideline - these temperatures may vary for different power sizes, enclosures etc.). Automation VT Drive has an auto derating function to avoid its heatsink reaching 95 °C .
- The frequency converter is protected against short-circuits on motor terminals U, V, W.
- If a mains phase is missing, the frequency converter trips or issues a warning (depending on the load).
- Monitoring of the intermediate circuit voltage ensures that the frequency converter trips if the intermediate circuit voltage is too low or too high.
- The frequency converter is protected against earth faults on motor terminals U, V, W.

Mains supply (L1, L2, L3):

Supply voltage	200-240 V $\pm 10\%$
Supply voltage	380-480 V $\pm 10\%$
Supply voltage	525-600 V $\pm 10\%$
Supply voltage	525-690 V $\pm 10\%$

Mains voltage low / mains drop-out:

During low mains voltage or a mains drop-out, the FC continues until the intermediate circuit voltage drops below the minimum stop level, which corresponds typically to 15% below the FC's lowest rated supply voltage. Power-up and full torque cannot be expected at mains voltage lower than 10% below the FC's lowest rated supply voltage.

Supply frequency	50/60 Hz $+4/-6\%$
------------------	--------------------

The frequency converter power supply is tested in accordance with IEC61000-4-28, 50 Hz $+4/-6\%$.

Max. imbalance temporary between mains phases	3.0 % of rated supply voltage
True Power Factor (λ)	≥ 0.9 nominal at rated load
Displacement Power Factor ($\cos\phi$) near unity	(> 0.98)
Switching on input supply L1, L2, L3 (power-ups) \leq enclosure type A	maximum 2 times/min.
Switching on input supply L1, L2, L3 (power-ups) \geq enclosure type B, C	maximum 1 time/min.
Switching on input supply L1, L2, L3 (power-ups) \geq enclosure type D, E, F	maximum 1 time/2 min.
Environment according to EN60664-1	overvoltage category III/pollution degree 2

The unit is suitable for use on a circuit capable of delivering not more than 100.000 RMS symmetrical Amperes, 240/480 V maximum.

Motor output (U, V, W):

Output voltage	0 - 100% of supply voltage
Output frequency	0 - 1000 Hz*
Switching on output	Unlimited
Ramp times	1 - 3600 sec.

* *Dependent on power size.*

Torque characteristics:

Starting torque (Constant torque)	maximum 110% for 1 min.*
Starting torque	maximum 135% up to 0.5 sec.*
Overload torque (Constant torque)	maximum 110% for 1 min.*

* *Percentage relates to Automation VT Drive nominal torque.*

Cable lengths and cross sections:

Max. motor cable length, screened/armoured	Automation VT Drive: 150 m
Max. motor cable length, unscreened/unarmoured	Automation VT Drive: 300 m
Max. cross section to motor, mains, load sharing and brake *	
Maximum cross section to control terminals, rigid wire	1.5 mm ² /16 AWG (2 x 0.75 mm ²)
Maximum cross section to control terminals, flexible cable	1 mm ² /18 AWG
Maximum cross section to control terminals, cable with enclosed core	0.5 mm ² /20 AWG
Minimum cross section to control terminals	0.25 mm ²

* *See Mains Supply tables for more information!*

Control card, RS-485 serial communication:

Terminal number	68 (P,TX+, RX+), 69 (N,TX-, RX-)
Terminal number 61	Common for terminals 68 and 69

The RS-485 serial communication circuit is functionally seated from other central circuits and galvanically isolated from the supply voltage (PELV).

Analog inputs:

Number of analog inputs	2
Terminal number	53, 54
Modes	Voltage or current
Mode select	Switch S201 and switch S202
Voltage mode	Switch S201/switch S202 = OFF (U)
Voltage level	: 0 to + 10 V (scaleable)
Input resistance, R_i	approx. 10 k Ω
Max. voltage	\pm 20 V
Current mode	Switch S201/switch S202 = ON (I)
Current level	0/4 to 20 mA (scaleable)
Input resistance, R_i	approx. 200 Ω
Max. current	30 mA
Resolution for analog inputs	10 bit (+ sign)
Accuracy of analog inputs	Max. error 0.5% of full scale
Bandwidth	: 200 Hz

The analog inputs are galvanically isolated from the supply voltage (PELV) and other high-voltage terminals.

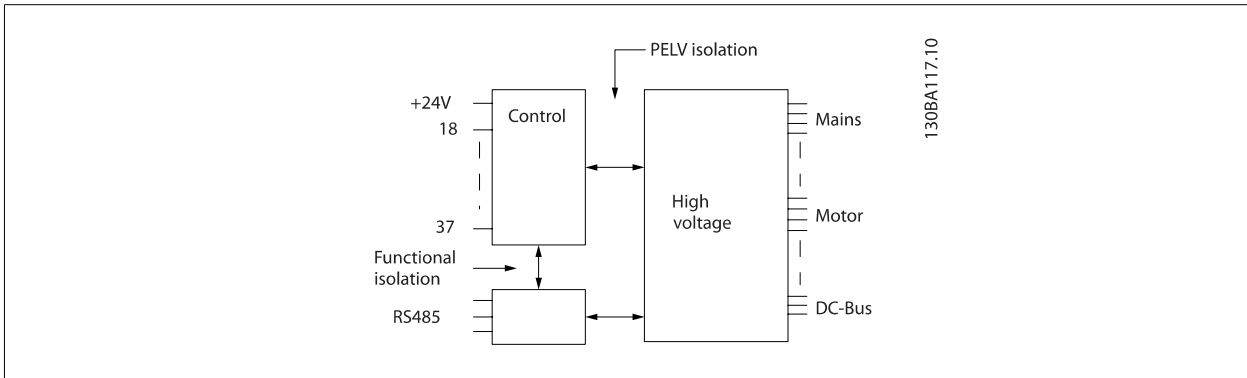

10

Analog output:

Number of programmable analog outputs	1
Terminal number	42
Current range at analog output	0/4 - 20 mA
Max. resistor load to common at analog output	500 Ω
Accuracy on analog output	Max. error: 0.8 % of full scale
Resolution on analog output	8 bit

The analog output is galvanically isolated from the supply voltage (PELV) and other high-voltage terminals.

Digital inputs:

Programmable digital inputs	4 (6)
Terminal number	18, 19, 27 ¹⁾ , 29 ¹⁾ , 32, 33,
Logic	PNP or NPN
Voltage level	0 - 24 V DC
Voltage level, logic '0' PNP	< 5 V DC
Voltage level, logic '1' PNP	> 10 V DC
Voltage level, logic '0' NPN	> 19 V DC
Voltage level, logic '1' NPN	< 14 V DC
Maximum voltage on input	28 V DC
Input resistance, R_i	approx. 4 k

All digital inputs are galvanically isolated from the supply voltage (PELV) and other high-voltage terminals.

1) Terminals 27 and 29 can also be programmed as output.

Digital output:

Programmable digital/pulse outputs	2
Terminal number	27, 29 ¹⁾
Voltage level at digital/frequency output	0 - 24 V
Max. output current (sink or source)	40 mA
Max. load at frequency output	1 kΩ
Max. capacitive load at frequency output	10 nF
Minimum output frequency at frequency output	0 Hz
Maximum output frequency at frequency output	32 kHz
Accuracy of frequency output	Max. error: 0.1 % of full scale
Resolution of frequency outputs	12 bit

1) Terminal 27 and 29 can also be programmed as input.

The digital output is galvanically isolated from the supply voltage (PELV) and other high-voltage terminals.

Pulse inputs:

Programmable pulse inputs	2
Terminal number pulse	29, 33
Max. frequency at terminal, 29, 33	110 kHz (Push-pull driven)
Max. frequency at terminal, 29, 33	5 kHz (open collector)
Min. frequency at terminal 29, 33	4 Hz
Voltage level	see section on Digital input
Maximum voltage on input	28 V DC
Input resistance, R _i	approx. 4 kΩ
Pulse input accuracy (0.1 - 1 kHz)	Max. error: 0.1% of full scale

Control card, 24 V DC output:

Terminal number	12, 13
Max. load	: 200 mA

The 24 V DC supply is galvanically isolated from the supply voltage (PELV), but has the same potential as the analog and digital inputs and outputs.

Relay outputs:

Programmable relay outputs	2
Relay 01 Terminal number	1-3 (break), 1-2 (make)
Max. terminal load (AC-1) ¹⁾ on 1-3 (NC), 1-2 (NO) (Resistive load)	240 V AC, 2 A
Max. terminal load (AC-15) ¹⁾ (Inductive load @ cosφ 0.4)	240 V AC, 0.2 A
Max. terminal load (DC-1) ¹⁾ on 1-2 (NO), 1-3 (NC) (Resistive load)	60 V DC, 1A
Max. terminal load (DC-13) ¹⁾ (Inductive load)	24 V DC, 0.1A
Relay 02 Terminal number	4-6 (break), 4-5 (make)
Max. terminal load (AC-1) ¹⁾ on 4-5 (NO) (Resistive load) ²⁾³⁾	400 V AC, 2 A
Max. terminal load (AC-15) ¹⁾ on 4-5 (NO) (Inductive load @ cosφ 0.4)	240 V AC, 0.2 A
Max. terminal load (DC-1) ¹⁾ on 4-5 (NO) (Resistive load)	80 V DC, 2 A
Max. terminal load (DC-13) ¹⁾ on 4-5 (NO) (Inductive load)	24 V DC, 0.1A
Max. terminal load (AC-1) ¹⁾ on 4-6 (NC) (Resistive load)	240 V AC, 2 A
Max. terminal load (AC-15) ¹⁾ on 4-6 (NC) (Inductive load @ cosφ 0.4)	240 V AC, 0.2A
Max. terminal load (DC-1) ¹⁾ on 4-6 (NC) (Resistive load)	50 V DC, 2 A
Max. terminal load (DC-13) ¹⁾ on 4-6 (NC) (Inductive load)	24 V DC, 0.1 A
Min. terminal load on 1-3 (NC), 1-2 (NO), 4-6 (NC), 4-5 (NO)	24 V DC 10 mA, 24 V AC 20 mA
Environment according to EN 60664-1	overvoltage category III/pollution degree 2

1) IEC 60947 t 4 and 5

The relay contacts are galvanically isolated from the rest of the circuit by reinforced isolation (PELV).

2) Overvoltage Category II

3) UL applications 300 V AC 2A

Control card, 10 V DC output:

Terminal number	50
Output voltage	10.5 V \pm 0.5 V
Max. load	25 mA

The 10 V DC supply is galvanically isolated from the supply voltage (PELV) and other high-voltage terminals.

Control characteristics:

Resolution of output frequency at 0 - 1000 Hz	: \pm 0.003 Hz
System response time (terminals 18, 19, 27, 29, 32, 33)	: \leq 2 ms
Speed control range (open loop)	1:100 of synchronous speed
Speed accuracy (open loop)	30 - 4000 rpm: Maximum error of \pm 8 rpm

All control characteristics are based on a 4-pole asynchronous motor

Surroundings:

Enclosure type A	IP 20/Chassis, IP 21kit/Type 1, IP55/Type12, IP 66
Enclosure type B1/B2	IP 21/Type 1, IP55/Type12, IP 66
Enclosure type B3/B4	IP20/Chassis
Enclosure type C1/C2	IP 21/Type 1, IP55/Type 12, IP66
Enclosure type C3/C4	IP20/Chassis
Enclosure type D1/D2/E1	IP21/Type 1, IP54/Type12
Enclosure type D3/D4/E2	IP00/Chassis
Enclosure kit available \leq enclosure type A	IP21/TYPPE 1/IP 4X top
Vibration test enclosure A/B/C	1.0 g
Vibration test enclosure D/E/F	0.7 g
Max. relative humidity	5% - 95%(IEC 721-3-3; Class 3K3 (non-condensing) during operation
Aggressive environment (IEC 721-3-3), uncoated	class 3C2
Aggressive environment (IEC 721-3-3), coated	class 3C3
Test method according to IEC 60068-2-43 H2S (10 days)	
Ambient temperature	Max. 50 °C

Derating for high ambient temperature, see section on special conditions

Minimum ambient temperature during full-scale operation	0 °C
Minimum ambient temperature at reduced performance	- 10 °C
Temperature during storage/transport	-25 - +65/70 °C
Maximum altitude above sea level without derating	1000 m
Maximum altitude above sea level with derating	3000 m

Derating for high altitude, see section on special conditions

EMC standards, Emission	EN 61800-3, EN 61000-6-3/4, EN 55011, IEC 61800-3 EN 61800-3, EN 61000-6-1/2,
EMC standards, Immunity	EN 61000-4-2, EN 61000-4-3, EN 61000-4-4, EN 61000-4-5, EN 61000-4-6

See section on special conditions

Control card performance:

Scan interval	: 5 ms
---------------	--------

Control card, USB serial communication:

USB standard	1.1 (Full speed)
USB plug	USB type B "device" plug



Connection to PC is carried out via a standard host/device USB cable.

The USB connection is galvanically isolated from the supply voltage (PELV) and other high-voltage terminals.

The USB connection is not galvanically isolated from protection earth. Use only isolated laptop/PC as connection to the USB connector on Automation VT Drive or an isolated USB cable/converter.

10.1 Special Conditions

10.2.1 Purpose of Derating

Derating must be taken into account when using the frequency converter at low air pressure (heights), at low speeds, with long motor cables, cables with a large cross section or at high ambient temperature. The required action is described in this section.

10.2.2 Derating for Low Air Pressure

The cooling capability of air is decreased at lower air pressure.

Below 1000 m altitude no derating is necessary but above 1000 m the ambient temperature (T_{AMB}) or max. output current (I_{out}) should be derated in accordance with the shown diagram.

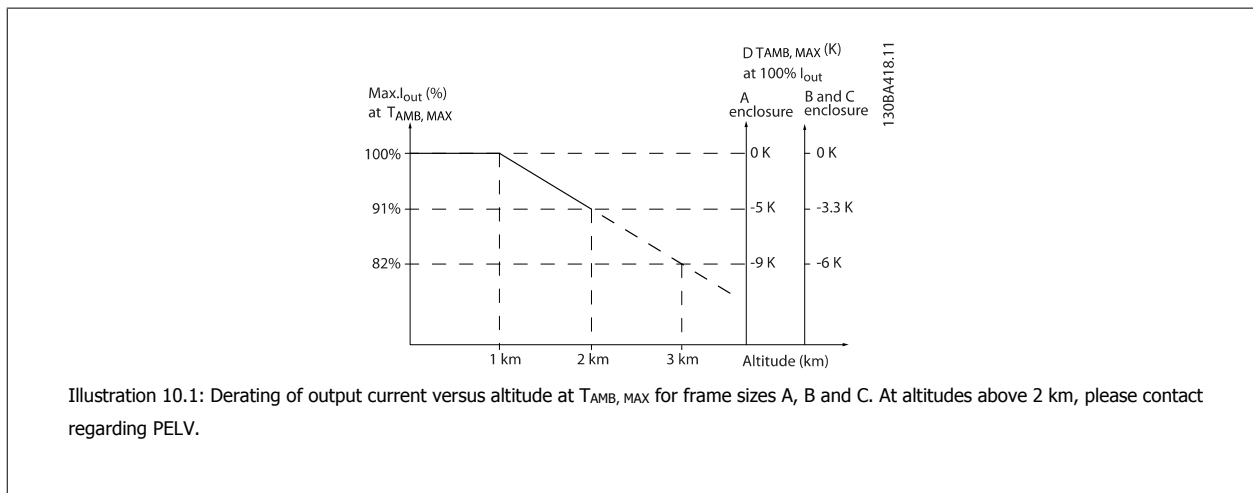

10

An alternative is to lower the ambient temperature at high altitudes and thereby ensure 100% output current at high altitudes. As an example of how to read the graph, the situation at 2 km is elaborated. At a temperature of 45° C ($T_{AMB, MAX}$ - 3.3 K), 91% of the rated output current is available. At a temperature of 41.7° C, 100% of the rated output current is available.

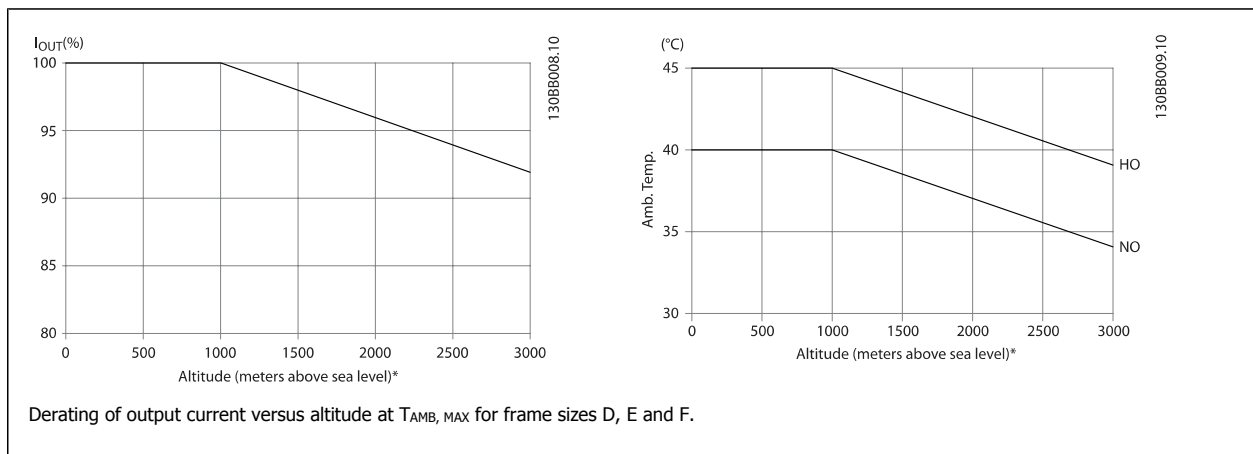

10.2.3 Derating for Running at Low Speed

When a motor is connected to a frequency converter, it is necessary to check that the cooling of the motor is adequate. The level of heating depends on the load on the motor, as well as the operating speed and time.

Constant torque applications (CT mode)

A problem may occur at low RPM values in constant torque applications. In a constant torque application a motor may over-heat at low speeds due to less cooling air from the motor integral fan.

Therefore, if the motor is to be run continuously at an RPM value lower than half of the rated value, the motor must be supplied with additional air-cooling (or a motor designed for this type of operation may be used).

An alternative is to reduce the load level of the motor by choosing a larger motor. However, the design of the frequency converter puts a limit to the motor size.

Variable (Quadratic) torque applications (VT)

In VT applications such as centrifugal pumps and fans, where the torque is proportional to the square of the speed and the power is proportional to the cube of the speed, there is no need for additional cooling or de-rating of the motor.

In the graphs shown below, the typical VT curve is below the maximum torque with de-rating and maximum torque with forced cooling at all speeds.

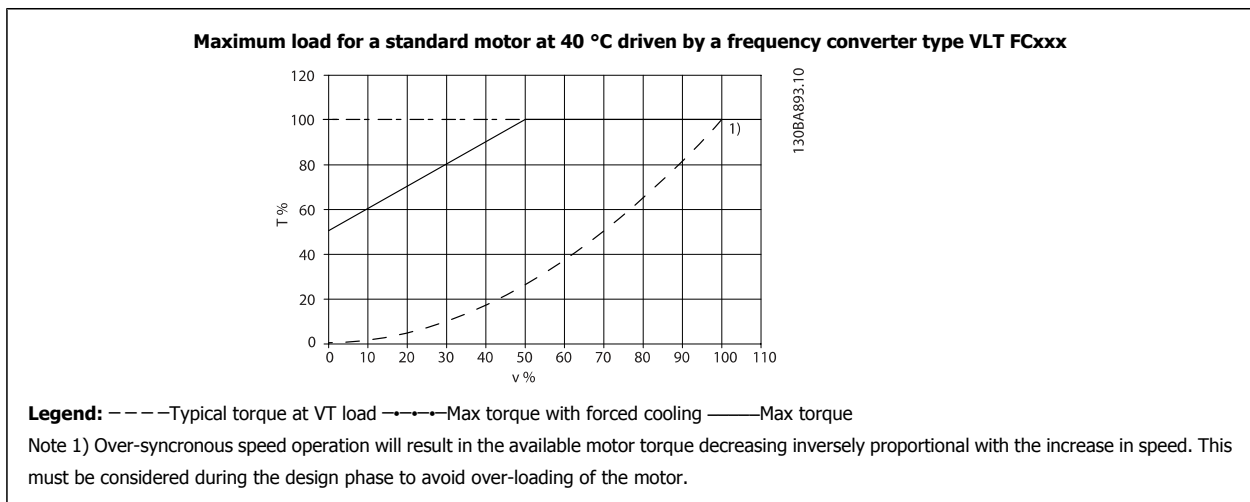

10.2.4 Automatic Adaptations to Ensure Performance

The frequency converter constantly checks for critical levels of internal temperature, load current, high voltage on the intermediate circuit and low motor speeds. As a response to a critical level, the frequency converter can adjust the switching frequency and / or change the switching pattern in order to ensure the performance of the frequency converter. The capability to automatically reduce the output current extends the acceptable operating conditions even further.

Index

A

Abbreviations And Standards	13
Acceleration Time	88
Access To Control Terminals	47
Alarm/warning Code List	156
Alarms And Warnings	155
Ama	57, 68
Analog I/o Option Mcb 109	149
Analog In/out	130
Analog Inputs	176
Analog Output	176
Application Functions	144
Automatic Adaptations To Ensure Performance	180
Automatic Motor Adaptation (ama)	53, 86
Available Literature For Automation Vt Drive	4
Awg	165

B

Brake Connection Option	41
Brakes	126
Bypass Option	153

C

Cable Lengths And Cross Sections	174
Cables General	21
Can Fieldbus	133
Can Motor	57
Cascade Controller	147
Caution	8
Changing A Group Of Numeric Data Values	66
Changing A Text Value	66
Changing Data	66
Changing Of Data Value	68
[Check Valve Ramp End Speed Hz] 3-87	90
[Check Valve Ramp End Speed Rpm] 3-86	90
Check Valve Ramp Time 3-85	89
Checklist	15
Coasting	63
Comm. And Options	131
Communication Option	161
Configuration Mode 1-00	85
Constant Torque Applications (ct Mode)	180
Control Cable Clamp	48
Control Cables	50
Control Cables	49
Control Card Performance	178
Control Card, 10 V Dc Output	178
Control Card, 24 V Dc Output	177
Control Card, Rs-485 Serial Communication:	174
Control Card, Usb Serial Communication	178
Control Characteristics	178
Control Terminals	48
Cooling	180
Cooling Conditions	19
Copyright, Limitation Of Liability And Revision Rights	4

D

Data Readouts	138
Data Readouts 2	140
Dc Bus Connection	39
Dc Link	158
Default Settings	69, 121
Derating For Low Air Pressure	179
Derating For Running At Low Speed	180
Digital In/out	129
Digital Inputs:	176
Digital Output	177
Display Line 1.1 Small, 0-20	79
Display Line 1.2 Small, 0-21	82
Display Line 1.3 Small, 0-22	82
Display Line 2 Large, 0-23	82
Display Line 3 Large, 0-24	82
Display Text 1 0-37	83
Display Text 2 0-38	83
Display Text 3 0-39	83
Disposal Instruction	9
Drive Closed Loop, 20-**	104
Dry Pump Delay 22-27	109
Dry Pump Function 22-26	109
Dst/summertime 0-74	84
Dst/summertime End 0-77	84
Dst/summertime Start 0-76	84

E

Earthing And It Mains	22
Efficient Parameter Set-up For Water Applications	55
Electrical Installation	49
Electrical Wiring	57
Electronic Waste	9
End Of Curve Delay 22-51	112
End Of Curve Function 22-50	112
Etr	158
Ext. Closed Loop	142

F

Fault Messages	158
Fc Closed Loop	141
Fc Information	136
Filled Setpoint, 29-05	120
Final Ramp Time 3-88	90
Flow At Rated Speed 22-90	115
Flow Compensation 22-80	112
Frequency Converter	53
Function Relay, 5-40	96

G

General Settings, 1-0*	85
General Warning	5
Gicp	68
Graphical Display	59

H

[High Speed Hz] 22-37	110
[High Speed Power Hp] 22-39	110

[High Speed Power Kw] 22-38	110
[High Speed Rpm] 22-36	110
How To Connect A Pc To The Frequency Converter	70
How To Connect Motor - Introduction	31
How To Connect To Mains And Earthing For B1 And B2	28
How To Operate Graphical Lcp (glcp)	59

I

Indexed Parameters	68
Indicator Lights (leds):	61
Initial Ramp Time, 3-84	89
Initialisation	69
Installation At High Altitudes	7
Intermediate Circuit	158

K

Kty Sensor	158
------------	-----

L

Language - Parameter, 0-01	79
Language Package 1	79
Language Package 2	79
Language Package 3	79
Language Package 4	79
Lcp	68
Lcp 102	59
Leakage Current	8
Leds	59
Limits / Warnings	128
Live Zero Timeout Function 6-01	99
Live Zero Timeout Time 6-00	99
Load/motor	124
Low Power Auto Set-up 22-20	108
Low Power Detection 22-21	108
Low Speed Detection 22-22	108
[Low Speed Hz] 22-33	110
[Low Speed Power Hp] 22-35	110
[Low Speed Power Kw] 22-34	110
[Low Speed Rpm] 22-32	109

M

Main Menu	73
Main Menu Mode	62
Main Menu Mode	77
Main Reactance	86
Mains Connection For A2 And A3	24
Mains Connection For B1, B2 And B3	28
Mains Connection For B4, C1 And C2	29
Mains Connection For C3 And C4	30
Mains Supply	165, 171, 172
Mains Supply (L1, L2, L3)	174
Mains Supply 1 X 200 - 240 Vac	164
Mains Wiring Overview	23
Maximum Boost Time 22-46	111
Maximum Reference 3-03	87
Mct 10	71
Mechanical Dimensions	18
Mechanical Mounting	19
Minimum Reference 3-02	87
Minimum Run Time 22-40	110

Minimum Sleep Time 22-41	111
Motor Connection For C3 And C4	38
Motor Current 1-24	86
Motor Frequency 1-23	85
Motor Name Plate	53
Motor Nominal Speed 1-25	86
Motor Output	174
[Motor Power Kw] 1-20	85
Motor Protection	174
[Motor Speed High Limit Rpm] 4-13	91
[Motor Speed Low Limit Rpm] 4-11	91
Motor Voltage 1-22	85
Motor Wiring Overview	0

N

Name Plate Data	53
Name Plate Data.	53
Nlcp	64
No-flow Delay 22-24	109
No-flow Function 22-23	109
No-flow Power 22-30	109

O

Occurrence 23-04	119
Off Action 23-03	118
Off Time 23-02	118
On Action 23-01	116
On Time 23-00	116
Operation/display	122
Output Performance (u, V, W)	174

P

Panel Through Mounting	20
Parameter Lists -	150
Parameter Options	121
Parameter Selection	78
Parameter Set-up	73
Pc Software Tools	70
Pid Integral Time 20-94	107
Pid Normal/inverse Control, 20-81	106
Pid Proportional Gain 20-93	106
[Pid Start Speed Rpm] 20-82	106
Pipe Fill Enable, 29-00	119
Pipe Fill Rate, 29-04	120
[Pipe Fill Speed Hz], 29-02	120
[Pipe Fill Speed Rpm], 29-01	119
Pipe Fill Time, 29-03	120
Power Correction Factor 22-31	109
Preset Reference 3-10	88
Pressure At No-flow Speed 22-87	115
Pressure At Rated Speed 22-88	115
Profibus	132
Profibus Dp-v1	71
Protection And Features	173
Pulse Inputs	177

Q

Q1 My Personal Menu	74
Q2 Quick Setup	74
Q3 Function Setups	75

Q5 Changes Made	76
Q6 Loggings	77
Quick Menu	55, 62, 73
Quick Menu Mode	62
Quick Transfer Of Parameter Settings When Using Glcp	68

R

Ramp 1 Ramp Down Time 3-42	88
Ramp 1 Ramp Up Time 3-41	88
Reference / Ramps	127
Reference/feedback Unit, 20-12	104
Relay Connection	42
Relay Output	46
Relay Outputs	177
Reset	64
Residual Current Device	8
Rs-485 Bus Connection	70

S

Safety Note	7
Safety Requirements Of Mechanical Installation	20
Screened/armoured.	50
Serial Communication	178
Set Date And Time, 0-70	83
Setpoint 1 20-21	106
Setpoint Boost 22-45	111
Side-by-side Installation	19
Sine-wave Filter	31
Sine-wave Filter	57
Smart Logic	134
Software Version	3
Special Functions	135
[Speed At Design Point Hz] 22-86	115
[Speed At Design Point Rpm] 22-85	114
[Speed At No-flow Hz] 22-84	114
[Speed At No-flow Rpm] 22-83	114
Square-linear Curve Approximation 22-81	112
Start/stop	56
Stator Leakage Reactance	86
Status	62
Status Messages	59
Step-by-step	68
Submersible Pump	57
Surroundings	178
Switches S201, S202 And S801	52

T

Term. 29 High Ref./feedb. Value 5-53	98
Terminal 27 Mode 5-01	92
Terminal 42 Output 6-50	101
Terminal 42 Output Max Scale 6-52	102
Terminal 42 Output Min Scale 6-51	102
Terminal 53 High Ref./feedb. Value 6-15	100
Terminal 53 High Voltage 6-11	100
Terminal 53 Low Ref./feedb. Value 6-14	100
Terminal 53 Low Voltage 6-10	100
Terminal 54 High Ref./feedb. Value 6-25	101
Terminal 54 High Voltage 6-21	100
Terminal 54 Low Ref./feedb. Value 6-24	101
Terminal 54 Low Voltage 6-20	100
Tightening Of Terminals	21

Time Format 0-72	84
Timed Actions	116, 146
Torque Characteristics	174
Type Code String - Medium Power	11
Type Code String (t/c)	13

U

Unpacking Table	15
Usb Connection	48

V

Variable (quadratic) Torque Applications (vt)	180
Voltage Level	176

W

Wake-up Ref./fb Difference 22-44	111
[Wake-up Speed Hz] 22-43	111
[Wake-up Speed Rpm] 22-42	111
Warning Against Unintended Start	7
Water Application Functions	152
Water Application Functions, 29-***	119
Wiring Example And Testing	46
Work Point Calculation 22-82	113