



Operating Instructions VLT[®] AQUA Drive FC 202

315-1400 kW



Contents

1 Introduction	4
1.1 Purpose of the Manual	4
1.2 Additional Resources	4
1.3 Document and Software Version	4
1.4 Approvals and Certifications	4
1.5 Disposal	5
1.6 Abbreviations and Conventions	5
2 Safety	7
2.1 Qualified Personnel	7
2.2 Safety Regulations	7
2.2.1 Discharge Time	7
2.2.2 Safe Torque Off (STO)	8
3 Mechanical Installation	9
3.1 Pre-installation	9
3.1.1 Planning the Installation Site	9
3.1.1.1 Inspection on Receipt	9
3.1.2 Receiving the Frequency Converter	9
3.1.3 Transportation and Unpacking	9
3.1.4 Lifting	9
3.1.5 Mechanical Dimensions	11
3.2 Mechanical Installation	15
3.2.1 Preparation for Installation	15
3.2.2 Tools Required	15
3.2.3 General Considerations	15
3.2.4 Terminal Locations, F8-F14	16
3.2.4.1 Inverter and Rectifier, Enclosure Sizes F8 and F9	16
3.2.4.2 Inverter, Enclosure Sizes F10 and F11	17
3.2.4.3 Inverter, Enclosure Sizes F12 and F13	18
3.2.4.4 Inverter, Enclosure Size F14	19
3.2.4.5 Rectifier, Enclosure Sizes F10, F11, F12 and F13	19
3.2.4.6 Rectifier, Enclosure Size F14	20
3.2.4.7 Options Cabinet, Enclosure Size F9	21
3.2.4.8 Options Cabinet, Enclosure Sizes F11/F13	22
3.2.5 Cooling and Airflow	22
3.3 Frame size F Panel Options	26
3.3.1 Panel Options	26
4 How to Install	28

4.1 Electrical Installation	28
4.1.1 Power Connections	28
4.1.2 Grounding	35
4.1.3 Extra Protection (RCD)	35
4.1.4 RFI Switch	35
4.1.5 Torque	35
4.1.6 Screened Cables	36
4.1.7 Motor Cable	36
4.1.8 Brake Cable for Frequency Converters with Factory-installed Brake Chopper Option	37
4.1.9 Shielding against Electrical Noise	37
4.1.10 Mains Connection	37
4.1.11 External Fan Supply	38
4.1.12 Fuses	38
4.1.13 Motor Insulation	41
4.1.14 Motor Bearing Currents	41
4.1.15 Brake Resistor Temperature Switch	41
4.1.16 Control Cable Routing	41
4.1.17 Access to Control Terminals	42
4.1.18 Electrical Installation, Control Terminals	42
4.2 Connection Examples	43
4.2.1 Start/Stop	43
4.2.2 Pulse Start/Stop	43
4.3 Electrical Installation - additional	45
4.3.1 Electrical Installation, Control Cables	45
4.3.2 Switches S201, S202 and S801	47
4.4 Final Set-up and Test	48
4.5 Additional Connections	49
4.5.1 Mechanical Brake Control	49
4.5.2 Parallel Connection of Motors	49
4.5.3 Motor Thermal Protection	50
5 How to operate the frequency converter	51
5.1.1 How to operate graphical LCP (GLCP)	51
5.1.2 How to Operate Numeric LCP (NLCP)	54
5.1.3 Changing Data	56
5.1.4 Changing a Text Value	56
5.1.5 Changing a Group of Numeric Data Values	56
5.1.6 Changing of Data Value, Step-by-Step	57
5.1.7 Readout and Programming of Indexed Parameters	57
5.1.8 Tips and Tricks	57

5.1.9 Quick Transfer of Parameter Settings when Using GLCP	57
5.1.10 Initialisation to Default Settings	57
5.1.11 RS-485 Bus Connection	58
5.1.12 How to Connect a PC to the Frequency Converter	58
5.1.13 PC Software Tools	59
6 How to programme the frequency converter	60
6.1 How to programme	60
6.1.7 Main Menu Mode	64
6.1.8 Parameter Selection	64
6.2 Commonly Used Parameters - Explanations	65
6.2.2 0-** Operation/Display	65
6.3 Parameter Options	93
6.3.1 Default Settings	93
7 General Specifications	98
8 Troubleshooting	109
Index	121

1 Introduction

1.1 Purpose of the Manual

The frequency converter is designed to provide high shaft performance on electrical motors. Read these operating instructions carefully for proper use. Incorrect handling of the frequency converter may cause improper operation of the frequency converter or related equipment, shorten lifetime or cause other troubles.

These operating instructions provide information on:

- Start-up
- Installation
- Programming
- Troubleshooting
- *Chapter 1 Introduction* introduces the manual and informs about approvals, symbols, and abbreviations used in this manual.
- *Chapter 2 Safety* entails instructions on how to handle the frequency converter in a safe way.
- *Chapter 3 Mechanical Installation* guides through the mechanical installations.
- *Chapter 4 How to Install* guides through the electrical installations.
- *Chapter 5 How to operate the frequency converter* explains how to operate the frequency converter via the LCP.
- *Chapter 6 How to programme the frequency converter* explains how to programme the frequency converter via the LCP.
- *Chapter 7 General Specifications* contains technical data about the frequency converter.
- *Chapter 8 Troubleshooting* assists in solving problems that may occur when using the frequency converter.

VLT® is a registered trademark.

1.2 Additional Resources

- *VLT® AQUA Drive FC 202 Operating Instructions* provide the necessary information for getting the frequency converter up and running.
- *VLT® AQUA Drive FC 202, 110-1400 kW Operating Instructions* provide the necessary information for getting the high power frequency converter up and running.

- *VLT® AQUA Drive FC 202 Design Guide* entails all technical information about the frequency converter and customer design and applications.
- *VLT® AQUA Drive FC 202 Programming Guide* provides information on how to programme and includes complete parameter descriptions.
- *VLT® AQUA Drive FC 202 Profibus*
- *VLT® AQUA Drive FC 202 DeviceNet*
- *Output Filters Design Guide*
- *VLT® AQUA Drive FC 202 Cascade Controller*
- *Application Note MN20A: Submersible Pump Application*
- *Application Note MN20: Master/Follower Operation Application*
- *Application Note MN20F: Drive Closed Loop and Sleep Mode*
- *Installation Instruction for Mounting Brackets Enclosure type A5, B1, B2, C1 and C2 IP21, IP55 or IP66*
- *Instruction for Analog I/O Option MCB109*
- *Instruction for Panel through mount kit*
- *VLT® Active Filter Operating Instruction*

Danfoss technical literature is also available online at www.danfoss.com/BusinessAreas/DrivesSolutions/Documentations/Technical+Documentation.htm.

1.3 Document and Software Version

This manual is regularly reviewed and updated. All suggestions for improvement are welcome. *Table 1.1* shows the document version and the corresponding software version.

Edition	Remarks	Software version
MG21Y2xx	Replaces MG21Y1xx	2.2x

Table 1.1 Document and Software Version

1.4 Approvals and Certifications

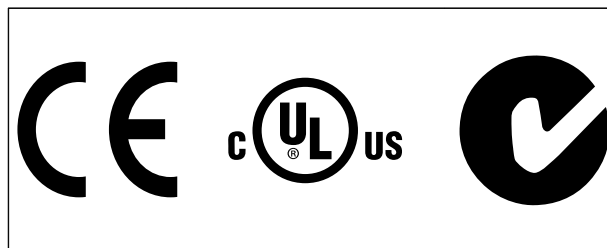

The frequency converter complies with UL508C thermal memory retention requirements. For more information, refer to the section *Motor Thermal Protection* in the product specific *design guide*.

NOTICE

Imposed limitations on the output frequency (due to export control regulations):

From software version 6.72 onwards, the output frequency of the frequency converter is limited to 590 Hz. Software versions 6x.xx also limit the maximum output frequency to 590 Hz, but these versions cannot be flashed, that is, neither downgraded nor upgraded.

1.5 Disposal

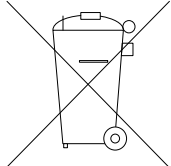

Do not dispose of equipment containing electrical components together with domestic waste.
Collect it separately in accordance with local and currently valid legislation.

1.6 Abbreviations and Conventions

60° AVM	60° Asynchronous vector modulation
A	Ampere/AMP
AC	Alternating current
AD	Air discharge
AEO	Automatic energy optimisation
AI	Analog input
AMA	Automatic motor adaptation
AWG	American wire gauge
°C	Degrees Celsius
CD	Contant discharge
CM	Common mode
CT	Constant torque
DC	Direct current
DI	Digital input
DM	Differential mode
D-TYPE	Drive dependent
EMC	Electro magnetic compatibility
ETR	Electronic thermal relay
f _{JOG}	Motor frequency when jog function is activated.
f _M	Motor frequency
f _{MAX}	The maximum output frequency the frequency converter applies on its output.
f _{MIN}	The minimum motor frequency from frequency converter
f _{M,N}	Nominal motor frequency
FC	Frequency converter
g	Gramme
Hiperface®	Hiperface® is a registered trademark by Stegmann

hp	Horsepower
HTL	HTL encoder (10-30 V) pulses - High-voltage transistor logic
Hz	Hertz
I _{INV}	Rated inverter output current
I _{LIM}	Current limit
I _{M,N}	Nominal motor current
I _{VLT,MAX}	The maximum output current
I _{VLT,N}	The rated output current supplied by the frequency converter
kHz	Kilohertz
LCP	Local control panel
lsb	Least significant bit
m	Meter
mA	Milliampere
MCM	Mille circular mil
MCT	Motion control tool
mH	Millihenry inductance
min	Minute
ms	Millisecond
msb	Most significant bit
η _{VLT}	Efficiency of the frequency converter defined as ratio between power output and power input.
nF	Nanofarad
NLCP	Numerical local control panel
Nm	Newton meters
n _s	Synchronous motor speed
On-line/Off-line Parameters	Changes to on-line parameters are activated immediately after the data value is changed.
P _{br,cont.}	Rated power of the brake resistor (average power during continuous braking).
PCB	Printed circuit board
PCD	Process data
PELV	Protective extra low voltage
P _m	Frequency converter nominal output power as HO.
P _{M,N}	Nominal motor power
PM motor	Permanent magnet motor
Process PID	The PID regulator maintains the desired speed, pressure, temperature, etc.
R _{br,nom}	The nominal resistor value that ensures a brake power on motor shaft of 150/160% for 1 minute
RCD	Residual current device
Regen	Regenerative terminals
R _{min}	Minimum permissible brake resistor value by frequency converter
RMS	Root mean square
RPM	Revolutions per minute
R _{rec}	Resistor value and resistance of the brake resistor
s	Second

SFAVM	Stator flux-oriented asynchronous vector modulation
STW	Status word
SMPS	Switch mode power supply
THD	Total harmonic distortion
T _{LIM}	Torque limit
TTL	TTL encoder (5 V) pulses - transistor transistor logic
U _{M,N}	Nominal motor voltage
V	Volts
VT	Variable torque
VVC ⁺	Voltage vector control

Table 1.2 Abbreviations

Conventions

Numbered lists indicate procedures.

Bullet lists indicate other information and description of illustrations.

Italicised text indicates

- Cross reference
- Link
- Footnote
- Parameter name, parameter group name, parameter option

All dimensions are in mm [inch].

* indicates a default setting of a parameter.

2 Safety

The following symbols are used in this document:

⚠ WARNING

Indicates a potentially hazardous situation which could result in death or serious injury.

⚠ CAUTION

Indicates a potentially hazardous situation which could result in minor or moderate injury. It can also be used to alert against unsafe practices.

NOTICE

Indicates important information, including situations that can result in damage to equipment or property.

2.1 Qualified Personnel

Correct and reliable transport, storage, installation, operation, and maintenance are required for the trouble-free and safe operation of the frequency converter. Only qualified personnel are allowed to install or operate this equipment.

Qualified personnel are defined as trained staff, who are authorised to install, commission, and maintain equipment, systems, and circuits in accordance with pertinent laws and regulations. Additionally, the personnel must be familiar with the instructions and safety measures described in these operating instructions.

2.2 Safety Regulations

⚠ WARNING

HIGH VOLTAGE

Frequency converters contain high voltage when connected to AC mains input, DC power supply, or load sharing. Failure to perform installation, start-up, and maintenance by qualified personnel can result in death or serious injury.

- Installation, start-up, and maintenance must be performed by qualified personnel only.

⚠ WARNING

UNINTENDED START

When the frequency converter is connected to AC mains, DC power supply, or load sharing, the motor may start at any time. Unintended start during programming, service, or repair work can result in death, serious injury, or property damage. The motor can start by means of an external switch, a serial bus command, an input reference signal from the LCP, or after a cleared fault condition.

To prevent unintended motor start:

- Disconnect the frequency converter from the mains.
- Press [Off/Reset] on the LCP before programming parameters.
- The frequency converter, motor, and any driven equipment must be fully wired and assembled when the frequency converter is connected to AC mains, DC power supply, or load sharing.

2.2.1 Discharge Time

Voltage [V]	Minimum waiting time (minutes)	
	30	40
380-500 V		315-1000 kW
525-600 V	400-1400 kW	

Table 2.1 Discharge Time

⚠ WARNING

LEAKAGE CURRENT HAZARD

Leakage currents exceed 3.5 mA. Failure to ground the frequency converter properly can result in death or serious injury.

- Ensure the correct grounding of the equipment by a certified electrical installer.

⚠ WARNING**EQUIPMENT HAZARD**

Contact with rotating shafts and electrical equipment can result in death or serious injury.

- Ensure that only trained and qualified personnel perform installation, start up, and maintenance.
- Ensure that electrical work conforms to national and local electrical codes.
- Follow the procedures in these operating instructions.

⚠ WARNING**UNINTENDED MOTOR ROTATION
WINDMILLING**

Unintended rotation of permanent magnet motors can result in serious injury or equipment damage.

- Ensure that permanent magnet motors are blocked to prevent unintended rotation.

⚠ CAUTION**INTERNAL FAILURE HAZARD**

An internal failure in the frequency converter can result in serious injury, when the frequency converter is not properly closed.

- Ensure that all safety covers are in place and securely fastened before applying power.

2.2.2 Safe Torque Off (STO)

STO is an option. To run STO, additional wiring for the frequency converter is required. Refer to *VLT[®] Frequency Converters Safe Torque Off Operating Instructions* for further information.

3 Mechanical Installation

3.1 Pre-installation

3.1.1 Planning the Installation Site

NOTICE

Plan the installation of the frequency converter before commencing the installation. Neglecting this may result in extra work during and after installation.

Select the best possible operation site by considering the following (see details on the following pages, and the respective Design Guides):

- Ambient operating temperature
- Installation method
- How to cool the unit
- Position of the frequency converter
- Cable routing
- Ensure that the power source supplies the correct voltage and necessary current.
- Ensure that the motor current rating is within the maximum current from the frequency converter.
- If the frequency converter is without built-in fuses, ensure that the external fuses are rated correctly.

3.1.1.1 Inspection on Receipt

After receiving the delivery, immediately check whether the scope of delivery matches the shipping documents. Danfoss does not honour claims for faults registered at a later time. Register a complaint immediately:

- With the carrier in case of visible transport damage.
- With the responsible Danfoss representative in case of visible defects or incomplete delivery.

3.1.2 Receiving the Frequency Converter

When receiving the frequency converter, make sure that the packaging is intact, and be aware of any damage that might have occurred to the unit during transport. In case damage has occurred, immediately contact the shipping company to claim the damage.

3.1.3 Transportation and Unpacking

Locate the frequency converter as close as possible to the final installation site before unpacking.

Remove the box and handle the frequency converter on the pallet, as long as possible.

3.1.4 Lifting

Always lift the frequency converter via the dedicated lifting eyes.

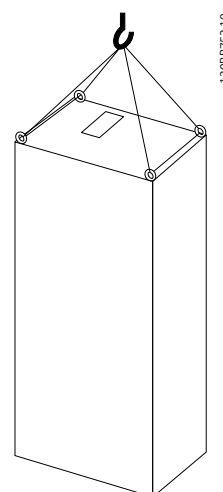

Illustration 3.1 Recommended Lifting Method, Enclosure Size F8.

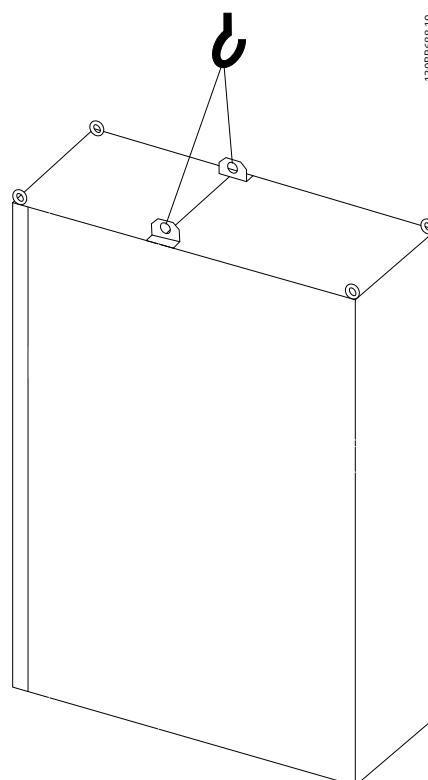

Illustration 3.2 Recommended Lifting Method, Enclosure Size F9/F10.

3

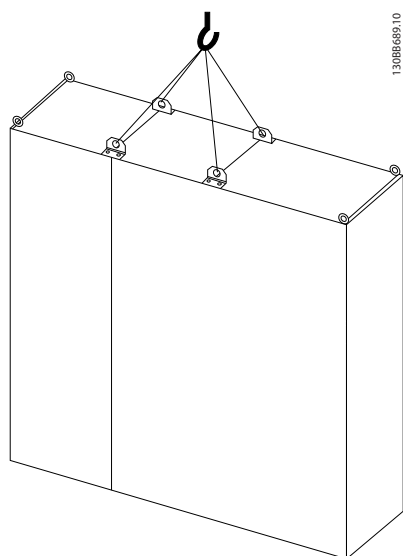
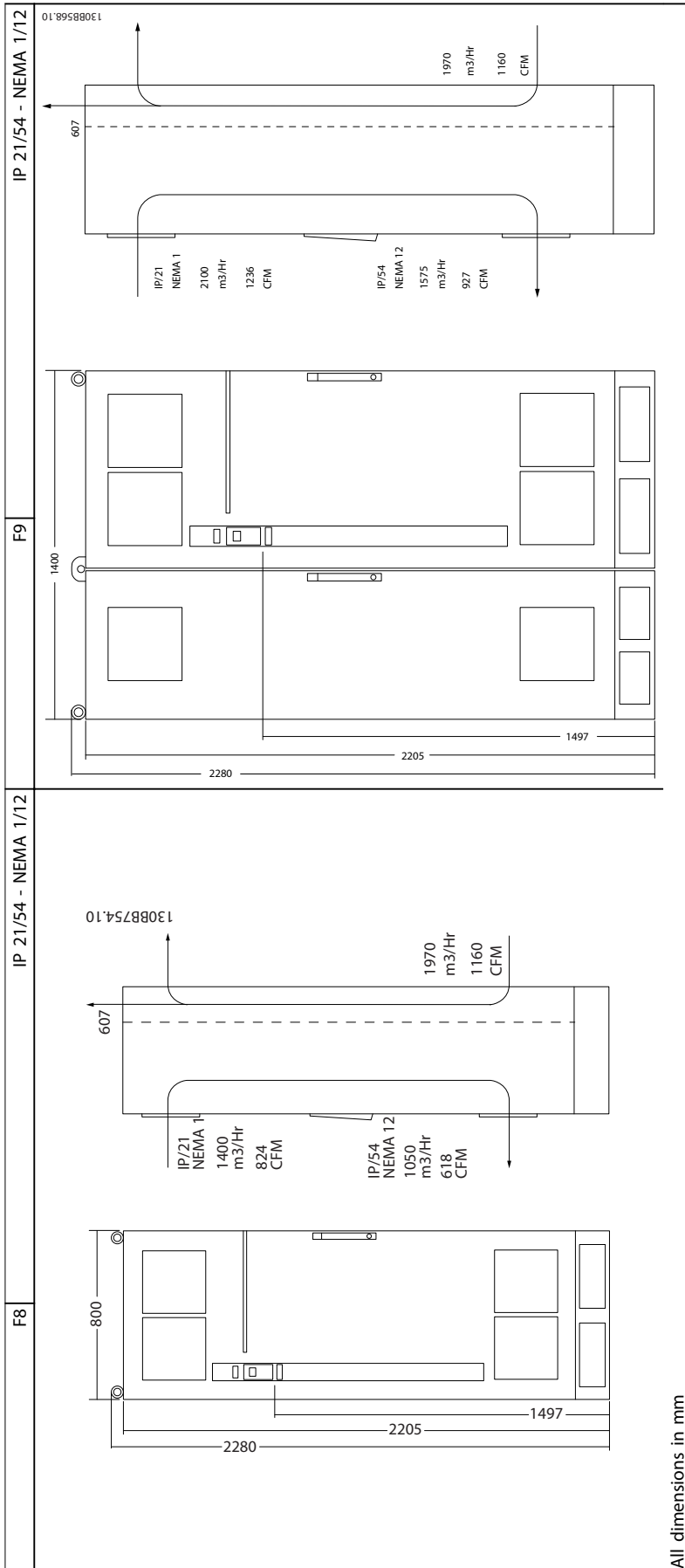

Illustration 3.3 Recommended Lifting Method, Enclosure Size F11/F12/F13/F14.

NOTICE

The plinth is provided in the same packaging as the frequency converter, but is not attached during shipment. The plinth is required to allow airflow cooling to the frequency converter. Position the frequency converter on top of the plinth in the final installation location. The angle from the top of the frequency converter to the lifting cable should be $>60^\circ$. In addition to *Illustration 3.1* to *Illustration 3.3*, a spreader bar can be used to lift the frequency converter.

3.1.5 Mechanical Dimensions



All dimensions in mm

Table 3.1

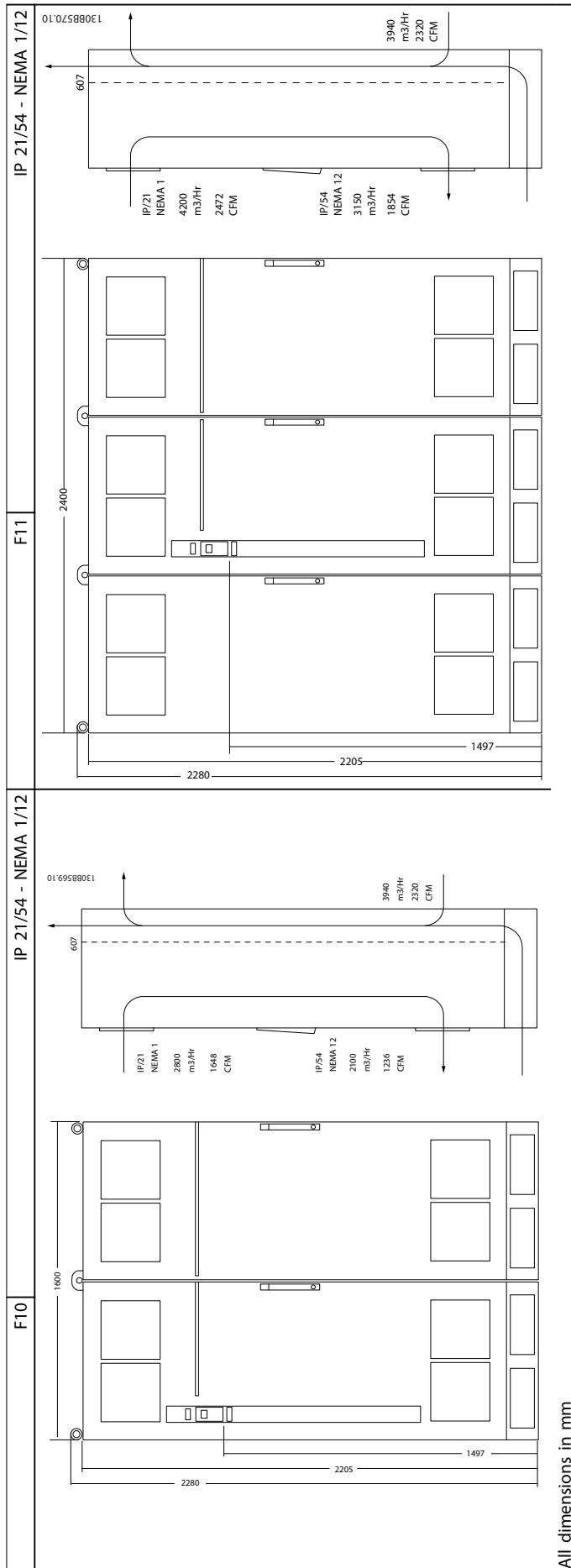
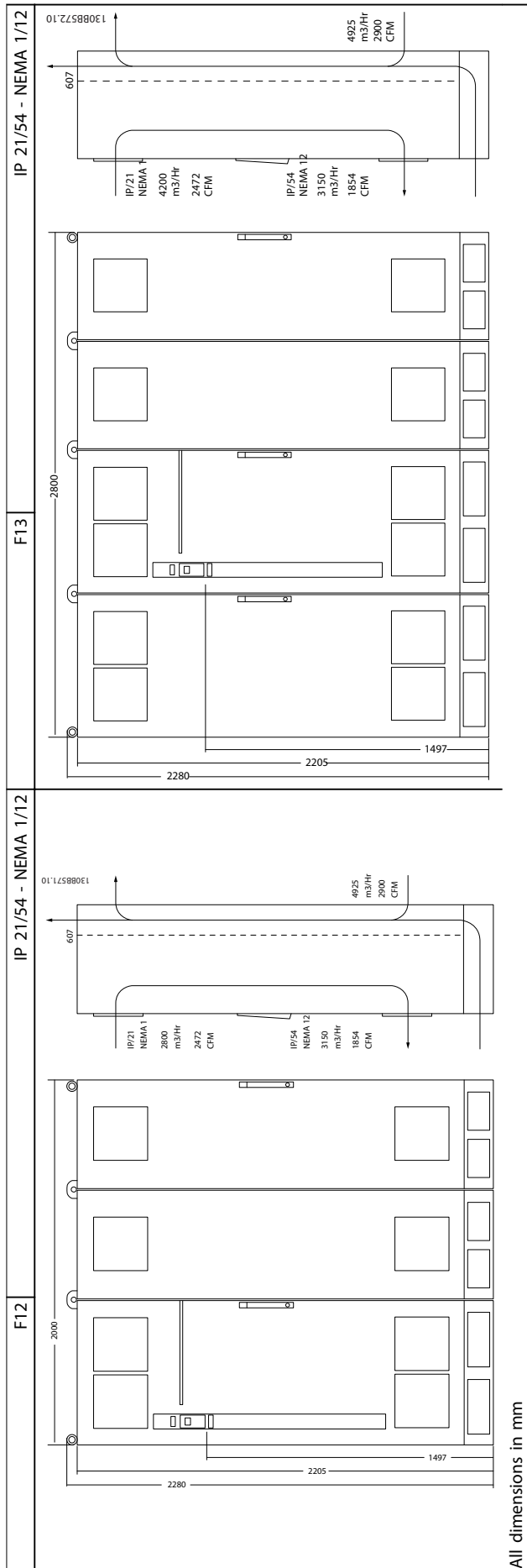

Table 3.2







Enclosure size		F8	F9	F10	F11	F12	F13
							
High overload rated power - 160% overload torque		315 - 450 kW (380 - 500 V) 400 - 630 kW (525-690 V)		500 - 710 kW (380 - 500 V) 710 - 900 kW (525-690 V)		800 - 1000 kW (380 - 500 V) 1000 - 1400 kW (525-690 V)	
IP NEMA		21, 54 Type 12		21, 54 Type 12		21, 54 Type 12	
Shipping dimensions [mm]	Height	2324	2324	2324	2324	2324	2324
	Width	970	1568	1760	2559	2160	2960
	Depth	1130	1130	1130	1130	1130	1130
Drive dimensions	Height	2204	2204	2204	2204	2204	2204
	Width	800	1400	1600	2200	2000	2600
	Depth	606	606	606	606	606	606
	Max weight [kg]	440	656	880	1096	1022	1238

Table 3.4 Mechanical Dimensions, Enclosure Sizes E and F

NOTICE

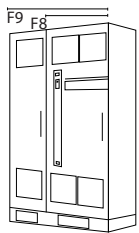
The F frames are available in 6 different sizes, F8, F9, F10, F11, F12 and F13. The F8, F10 and F12 consist of an inverter cabinet on the right and rectifier cabinet on the left. The F9, F11 and F13 have an additional options cabinet left of the rectifier cabinet. The F9 is an F8 with an additional options cabinet. The F11 is an F10 with an additional options cabinet. The F13 is an F12 with an additional options cabinet.

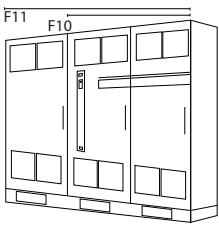
3.2 Mechanical Installation

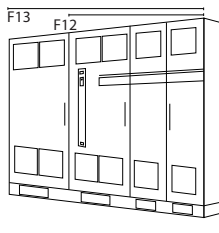
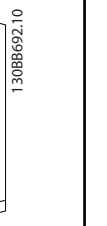
3.2.1 Preparation for Installation

Make the following preparations to ensure reliable and effective installation of the frequency converter:

- Provide a suitable mounting arrangement. The mounting arrangement depends on the design, weight, and torque of the frequency converter.
- Examine the mechanical drawings to ensure that the space requirements are met.
- Ensure that all wiring is done in accordance with national regulations.

3.2.2 Tools Required

- Drill with 10 or 12 mm bit.
- Tape measure.
- Wrench with relevant metric sockets (7-17 mm).
- Extensions to wrench.
- Sheet metal punch for conduits or cable glands in IP21/Nema 1 and IP54 units
- Lifting bar to lift the unit (rod or tube max. Ø 25 mm (1 inch), able to lift minimum 400 kg (880 lbs)).
- Crane or other lifting aid to place the frequency converter in position.

3.2.3 General Considerations

Space

Ensure sufficient space above and below the frequency converter to allow airflow and cable access. In addition, allow for enough space in front of the unit to open the panel door, see *Illustration 3.4* to *Illustration 3.10*.

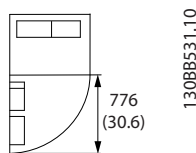

Illustration 3.4 Space in Front of Enclosure Size F8

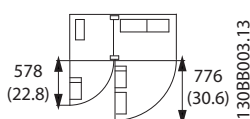

Illustration 3.5 Space in Front of Enclosure Size F9

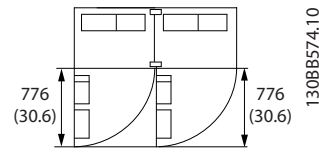

Illustration 3.6 Space in Front of Enclosure Size F10

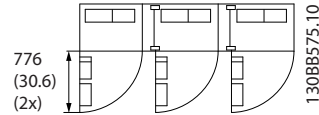

Illustration 3.7 Space in Front of Enclosure Size F11

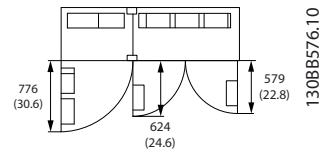

Illustration 3.8 Space in Front of Enclosure Size F12

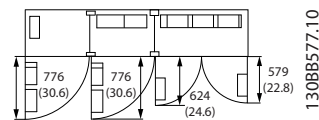

Illustration 3.9 Space in Front of Enclosure Size F13

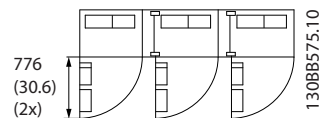

Illustration 3.10 Space in Front of Enclosure Size F14

Wire access

Ensure that proper wire access is present including the necessary bending allowance.

NOTICE

All cable lugs/shoes must mount within the width of the terminal bus bar.

3.2.4 Terminal Locations, F8-F14

The F enclosures are available in 7 different sizes, F8, F9, F10, F11, F12, F13, and F14. The F8, F10, F12, and F14 consist of an inverter cabinet on the right and rectifier cabinet on the left. The F9, F11 and F13 have an additional options cabinet left of the rectifier cabinet. The F9 is an F8 with an additional options cabinet. The F11 is an F10 with an additional options cabinet. The F13 is an F12 with an additional options cabinet.

3

3.2.4.1 Inverter and Rectifier, Enclosure Sizes F8 and F9

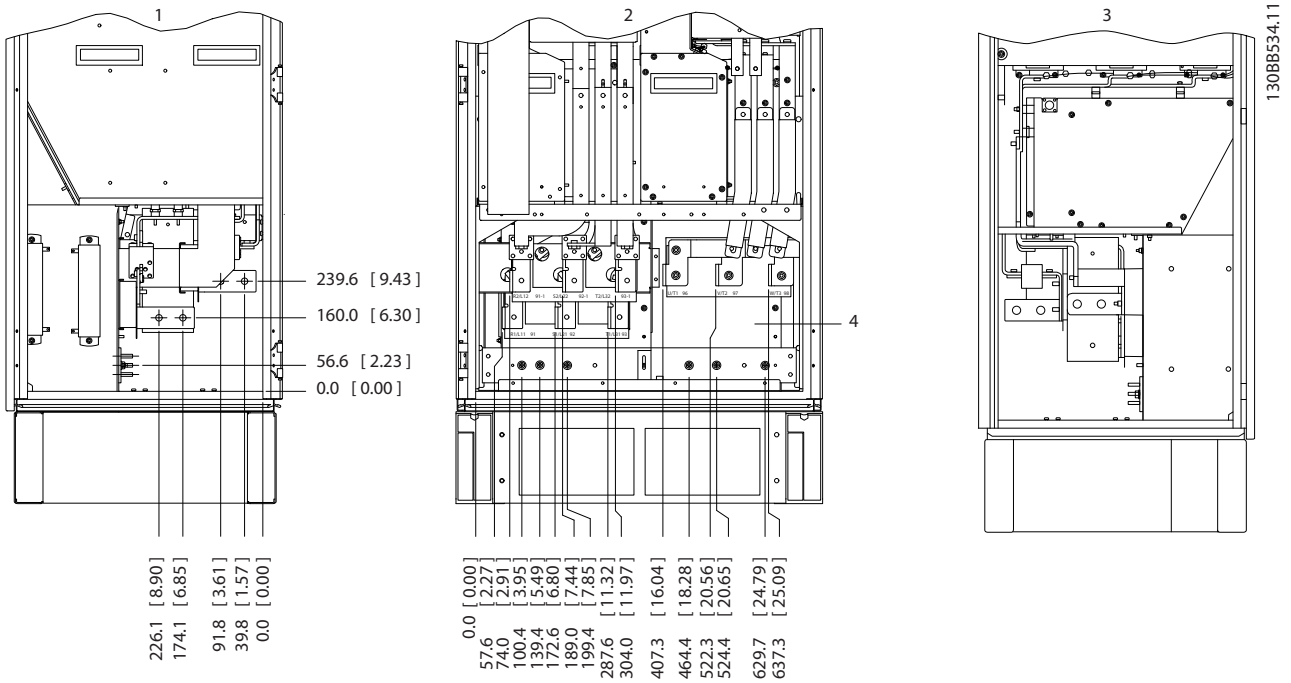

Illustration 3.11 Terminal Locations - Left, Front and Right Views. The gland plate is 42 mm below .0 level.

1) Ground bar

3.2.4.2 Inverter, Enclosure Sizes F10 and F11

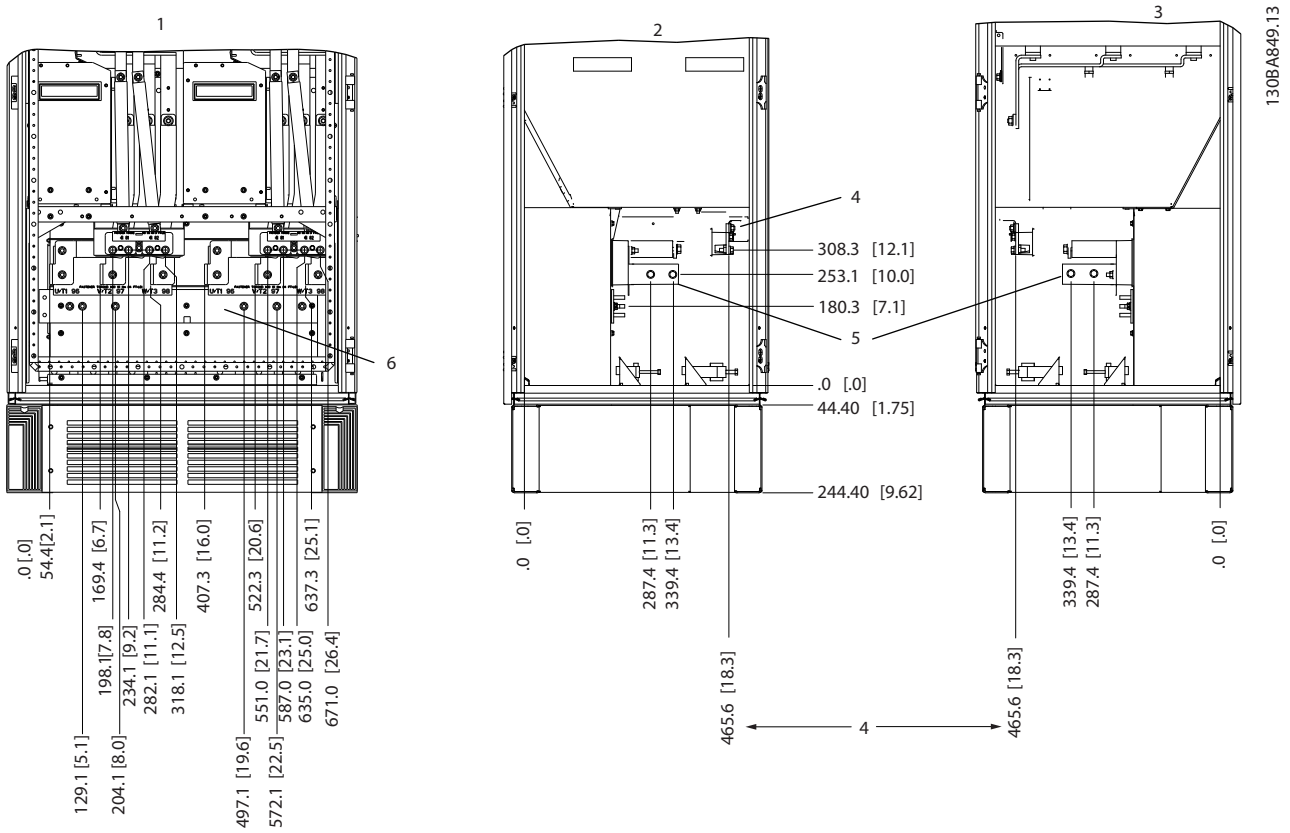

Illustration 3.12 Terminal Locations - Left, Front and Right Views. The gland plate is 42 mm below .0 level.

- 1) Ground bar
- 2) Motor terminals
- 3) Brake terminals



130BA849.13

3.2.4.3 Inverter, Enclosure Sizes F12 and F13

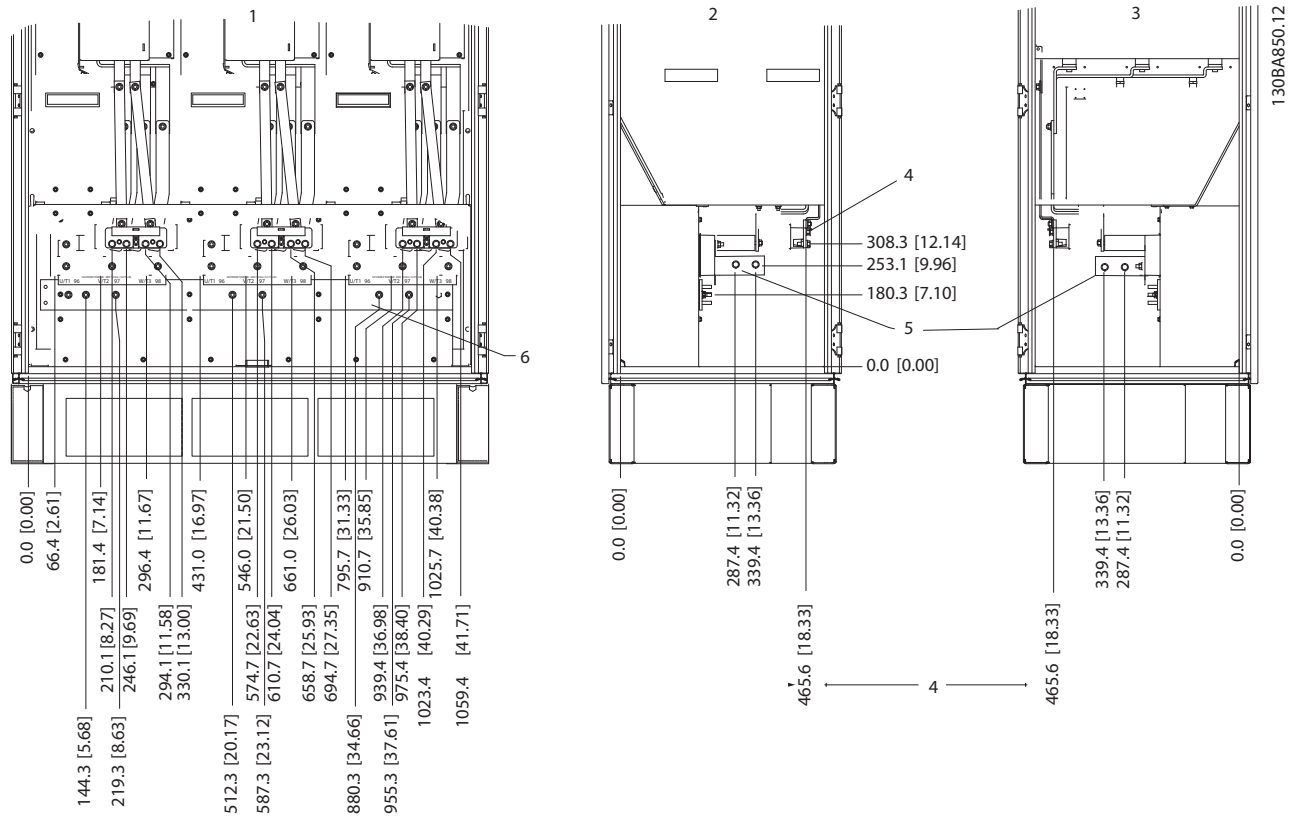
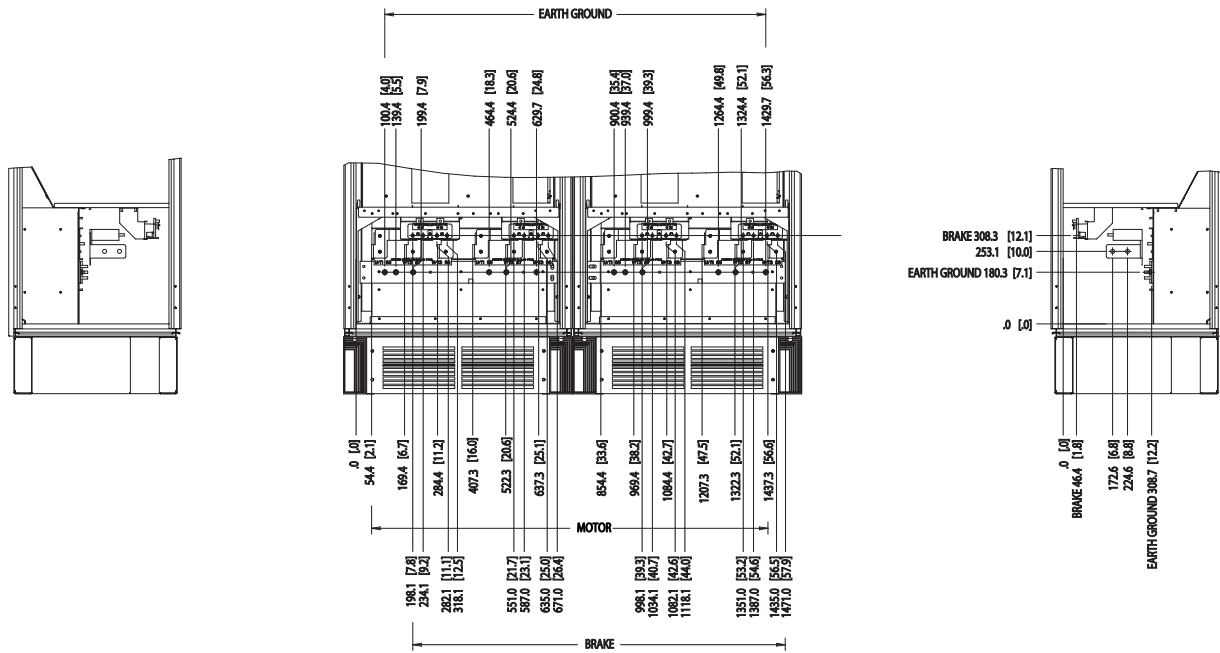

Illustration 3.13 Terminal Locations - Left, Front and Right Views. The gland plate is 42 mm below .0 level.

1) Ground bar

3.2.4.4 Inverter, Enclosure Size F14



1308C147.10

Illustration 3.14 Terminal Locations - Left, Front and Right Views. The gland plate is 42 mm below .0 level.

3.2.4.5 Rectifier, Enclosure Sizes F10, F11, F12 and F13

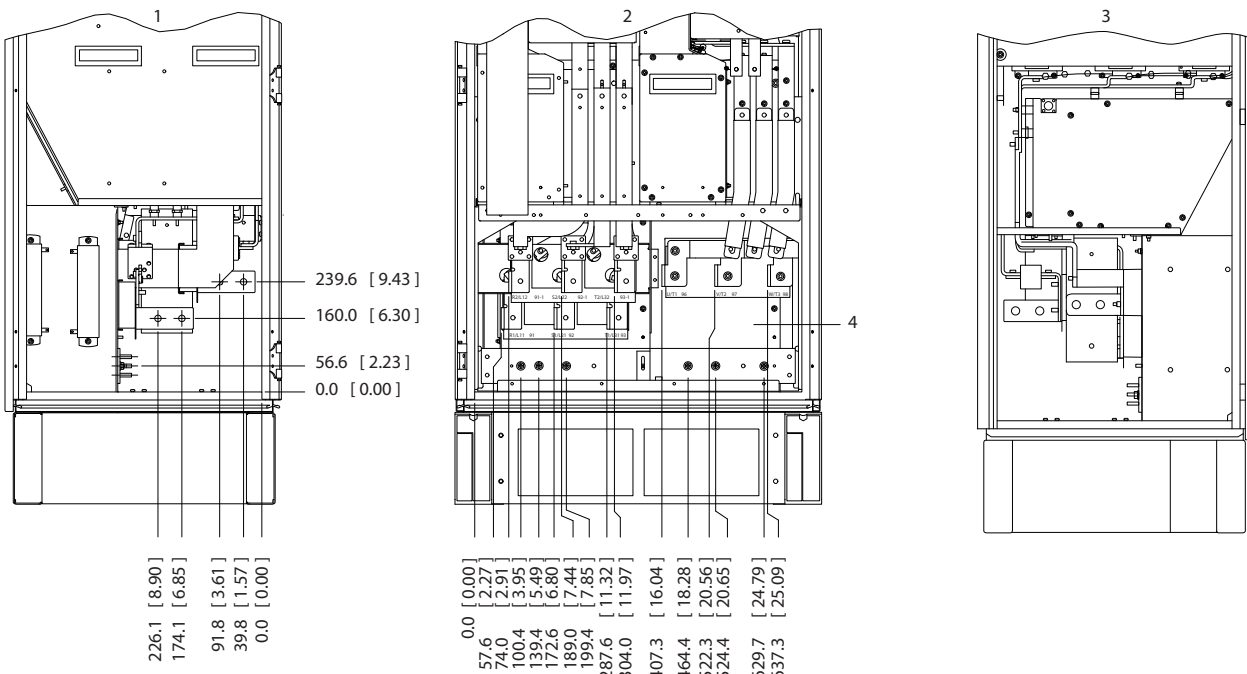

1308B534.11

Illustration 3.15 Terminal Locations - Left, Front and Right Views. The gland plate is 42 mm below .0 level.

- 1) Loadshare Terminal (-)
- 2) Ground bar
- 3) Loadshare Terminal (+)

3.2.4.6 Rectifier, Enclosure Size F14

3

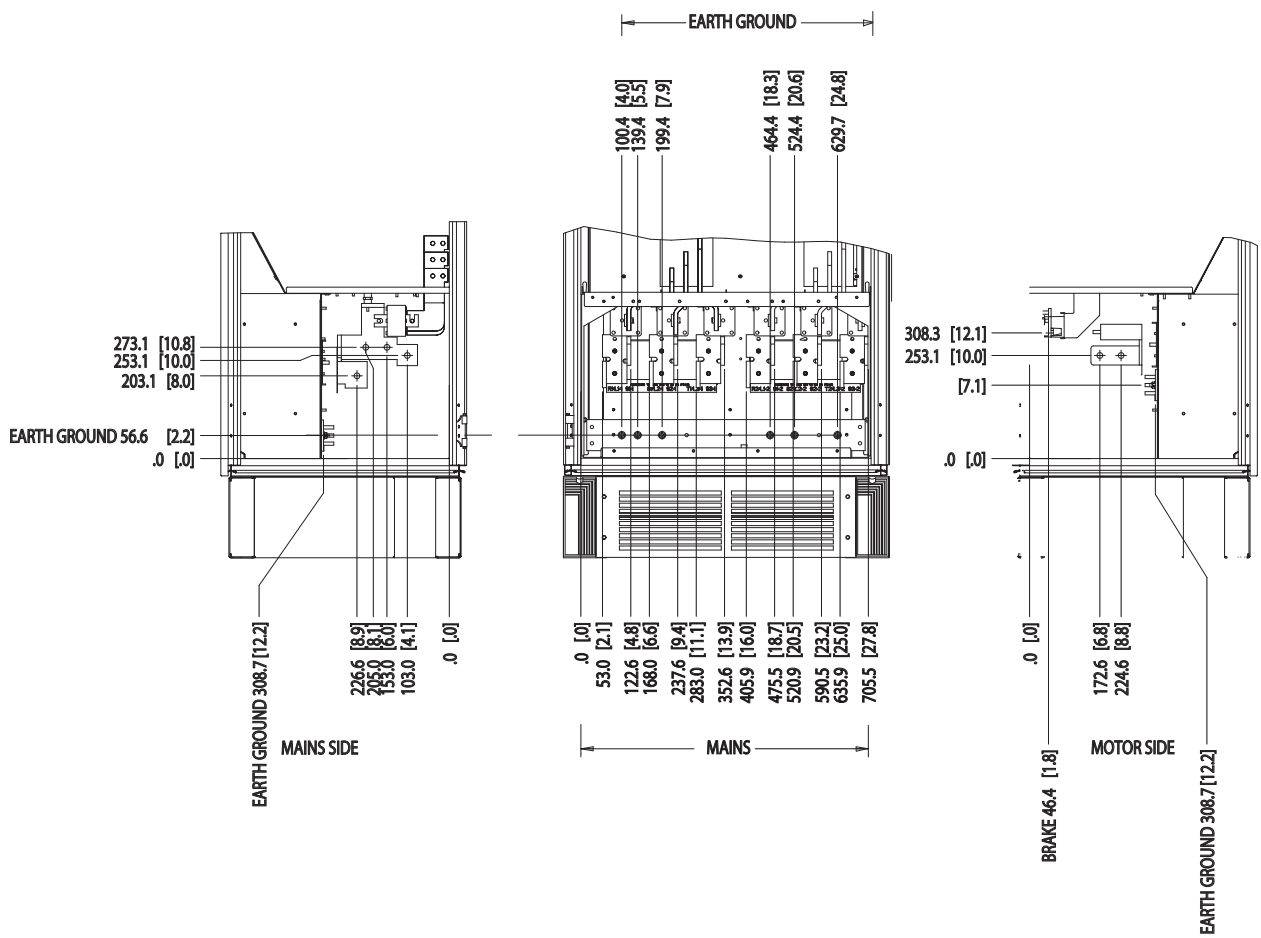

130BC146.10

Illustration 3.16 Terminal Locations - Left, Front and Right Views. The gland plate is 42 mm below .0 level.

3.2.4.7 Options Cabinet, Enclosure Size F9

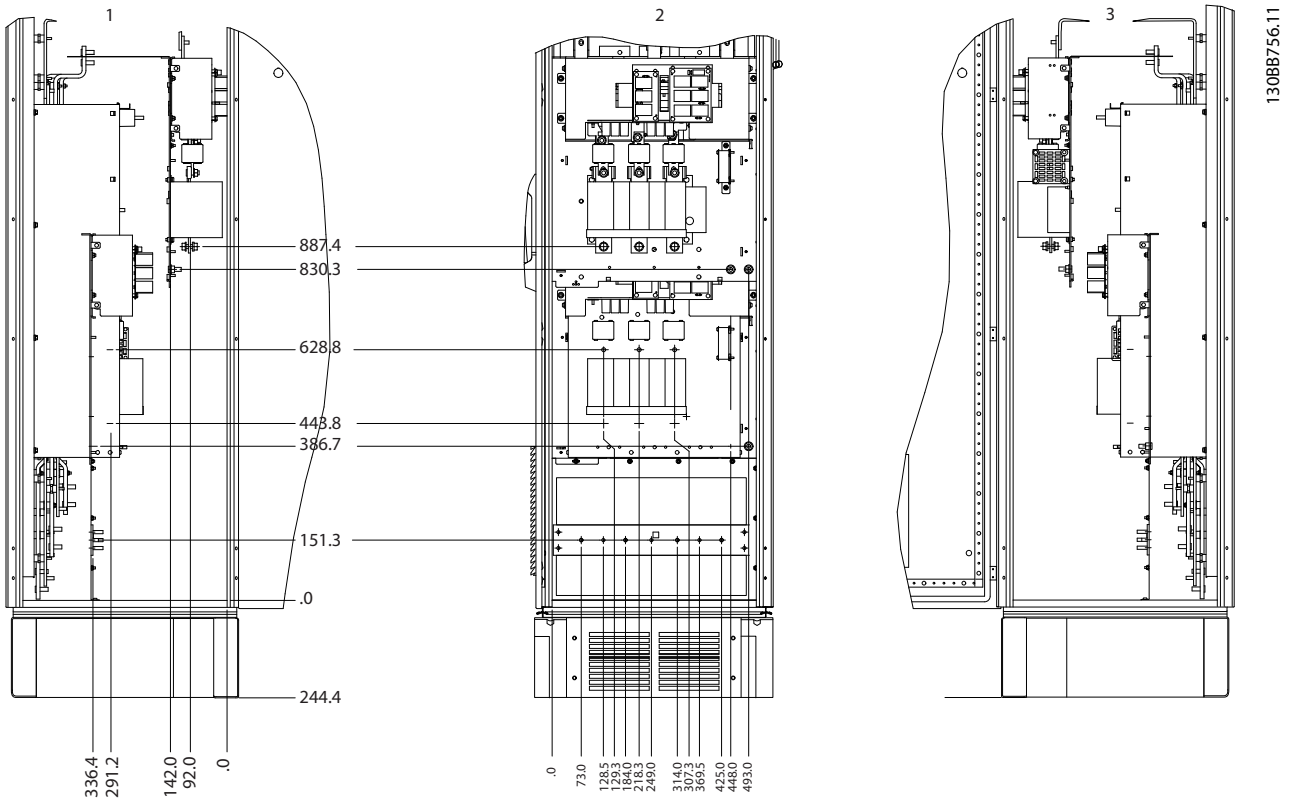

Illustration 3.17 Terminal Locations - Left, Front and Right Views

3

3.2.4.8 Options Cabinet, Enclosure Sizes F11/F13

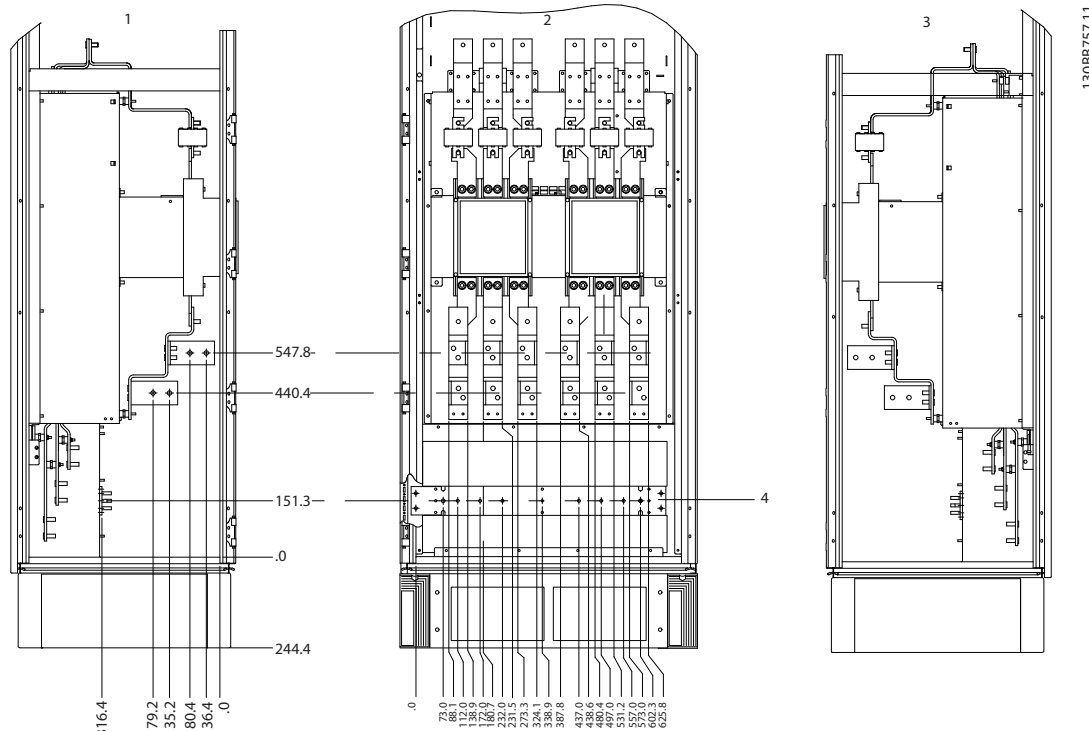

Illustration 3.18 Terminal Locations - Left, Front and Right Views

3.2.5 Cooling and Airflow

Cooling

Cooling can be achieved in different ways:

- By using the cooling ducts at the top and bottom of the unit.
- By taking air in and out the back of the unit.
- By combining the cooling methods.

Duct cooling

A dedicated option has been developed to optimise the installation of frequency converters in Rittal TS8 enclosures utilising the frequency converter fan for forced air cooling of the backchannel. The air out of the top of the enclosure could be ducted outside a facility so the heat losses from the backchannel are not dissipated within the control room. This ultimately reduces the air-conditioning requirements of the facility.

Back cooling

The backchannel air can also be ventilated in and out of the back of a Rittal TS8 enclosure. The backchannel takes cool air from outside the facility and returns warm air to outside the facility, thus reducing air-conditioning requirements.

Airflow

Ensure sufficient airflow over the heat sink. The flow rate is shown in Table 3.5.

Enclosure protection	Door fan(s)/Top fan airflow	Heat sink fan(s)
IP21/NEMA 1	700 m ³ /h (412 cfm)*	985 m ³ /h (580 cfm)*
IP54/NEMA 12	525 m ³ /h (309 cfm)*	985 m ³ /h (580 cfm)*

Table 3.5 Heat Sink Air Flow

* Airflow per fan. Enclosure sizes F contain multiple fans.

NOTICE

The fan runs for the following reasons:

- AMA
- DC Hold
- Pre-Mag
- DC Brake
- 60% of nominal current is exceeded.
- Specific heat sink temperature exceeded (power size dependent).

The fan runs for minimum 10 minutes.

External ducts

If additional duct work is added externally to the Rittal cabinet, calculate the pressure drop in the ducting. To derate the frequency converter according to the pressure drop, refer to Illustration 3.19.

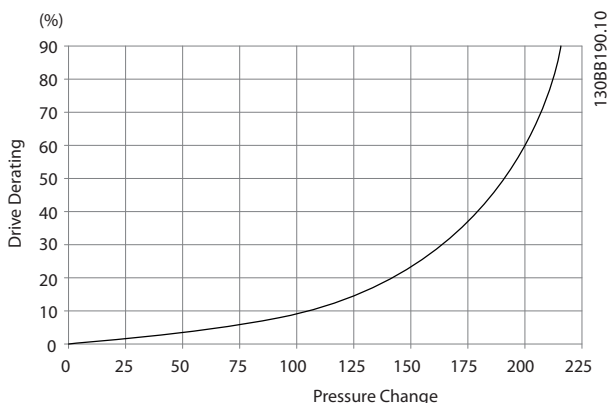

Illustration 3.19 Enclosure Size F, Derating vs. Pressure Change (Pa)

Drive air flow: 985 m³/h (580 cfm)

3.2.6 Gland/Conduit Entry - IP21 (NEMA 1) and IP54 (NEMA12)

Cables are connected through the gland plate from the bottom. Remove the plate and plan where to place the entry for the glands or conduits. Prepare holes in the marked area on the drawings in *Table 3.6* and *Table 3.7*.

NOTICE

Fit the gland plate to the frequency converter to ensure the specified protection degree, as well as ensuring proper cooling of the unit. If the gland plate is not mounted, the frequency converter may trip on Alarm 69, Pwr. Card Temp

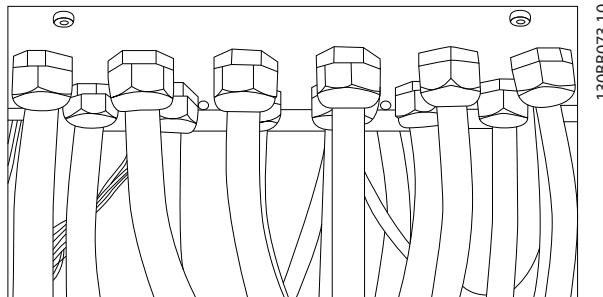
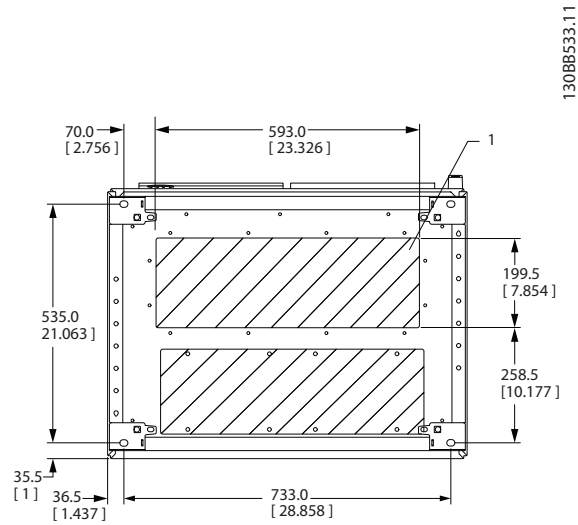
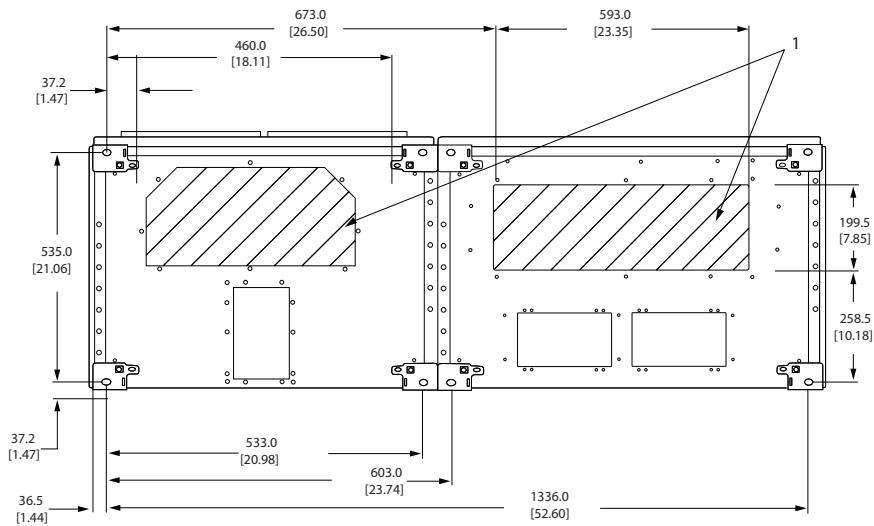

Illustration 3.20 Example of Proper Installation of the Gland Plate.

Enclosure Size F8



Enclosure Size F9



Enclosure Size F10

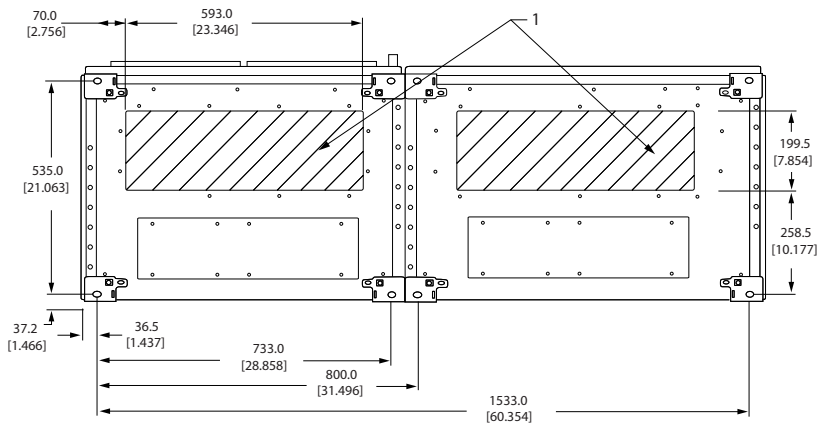

1 Place conduits in marked areas

Table 3.6 F8-F10: Cable Entries Viewed from the Bottom of the Frequency Converter

Enclosure Size F11

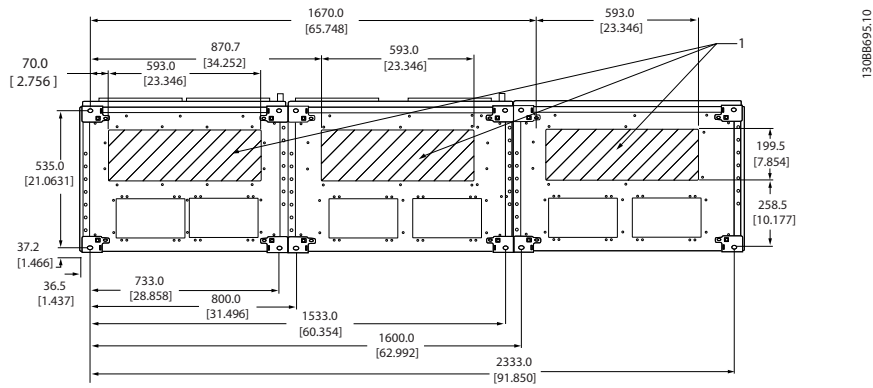

1308B695.10

Enclosure Size F12

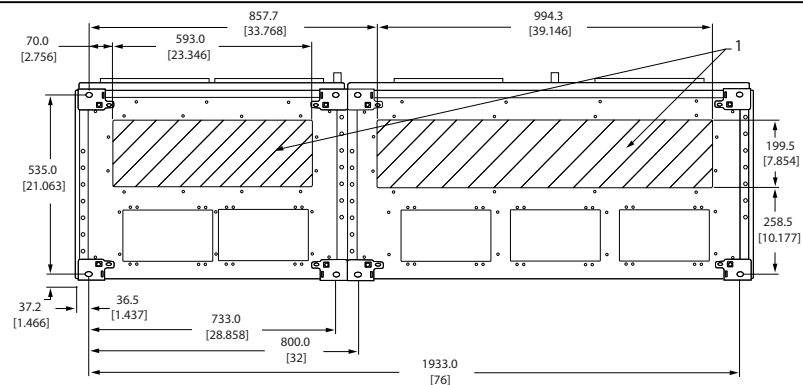

1308B696.10

Enclosure Size F13

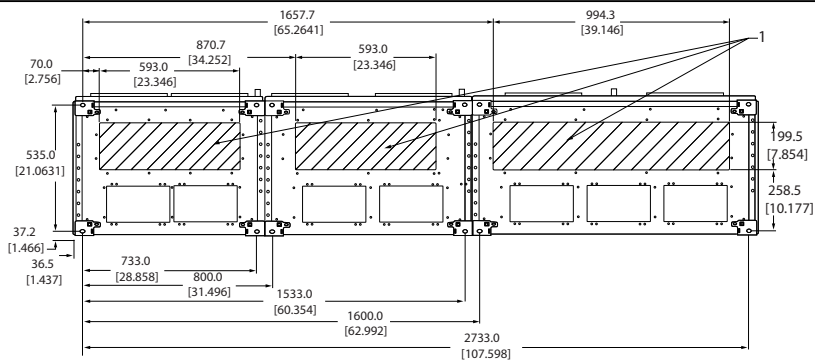

1308B697.10

Enclosure Size F 14

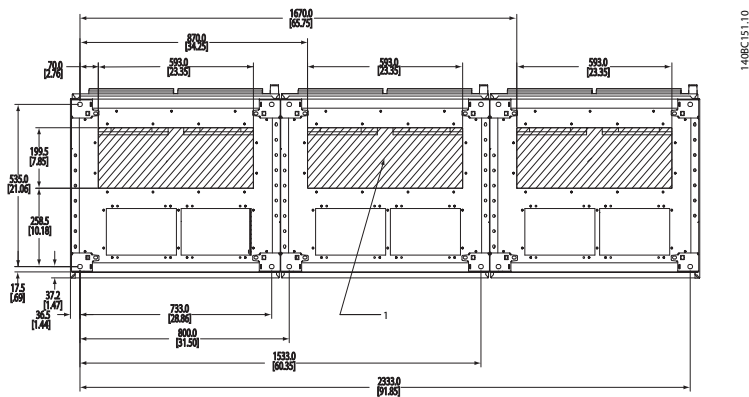

1408C151.10

1 Place conduits in marked areas

Table 3.7 F11-F14: Cable Entries Viewed from the Bottom of the Frequency Converter

3.3 Frame size F Panel Options

3.3.1 Panel Options

Space heaters and thermostat

Space heaters are mounted on the cabinet interior of enclosure size F10-F14 frequency converters. They are controlled via an automatic thermostat, and help control humidity inside the enclosure, thereby extending the lifetime of frequency converter components in damp environments. The thermostat default settings turn on the heaters at 10 °C (50 °F) and turn them off at 15.6 °C (60 °F).

Cabinet light with power outlet

A light mounted on the cabinet interior of enclosure size F10-F14 frequency converters increases visibility during servicing and maintenance. The housing light includes a power outlet for temporarily powering tools or other devices, available in 2 voltages:

- 230 V, 50 Hz, 2.5 A, CE/ENEC
- 120 V, 60 Hz, 5 A, UL/cUL

Transformer tap set-up

If the cabinet light and outlet, and/or the space heaters and thermostat are installed, transformer T1 requires the taps to be set to the proper input voltage. A 380-480/500 V unit is initially set to the 525 V tap and a 525-690 V unit is set to the 690 V tap. This ensures that no overvoltage of secondary equipment occurs if the tap is not changed before power is applied. See *Table 3.8* to set the proper tap at terminal T1, located in the rectifier cabinet. For location in the frequency converter, see the illustration of the rectifier in *Illustration 4.1*.

Input voltage range [V]	Tap to select [V]
380-440	400
441-490	460
491-550	525
551-625	575
626-660	660
661-690	690

Table 3.8 Transformer Tap Setting

NAMUR terminals

NAMUR is an international association of automation technology users in the process industries, primarily chemical and pharmaceutical industries in Germany. Selection of this option provides terminals organised and labeled to the specifications of the NAMUR standard for frequency converter input and output terminals. This requires an MCB 112 PTC Thermistor Card and an MCB 113 Extended Relay Card.

RCD (residual current device)

Uses the core balance method to monitor ground fault currents in grounded and high-resistance grounded systems (TN and TT systems in IEC terminology). There is a pre-warning (50% of main alarm setpoint) and a main

alarm setpoint. Associated with each setpoint is an SPDT alarm relay for external use. Requires an external *window-type* current transformer (not supplied).

- Integrated into the frequency converter's safe-stop circuit.
- IEC 60755 Type B device monitors AC, pulsed DC, and pure DC ground fault currents.
- LED bar graph indicator of the ground fault current level from 10-100% of the setpoint.
- Fault memory
- TEST/RESET button

IRM (insulation resistance monitor)

Monitors the insulation resistance in ungrounded systems (IT systems in IEC terminology) between the system phase conductors and ground. There is an ohmic pre-warning and a main alarm setpoint for the insulation level. Associated with each setpoint is an SPDT alarm relay for external use.

NOTICE

Only one insulation resistance monitor can be connected to each ungrounded (IT) system.

- Integrated into the frequency converter's safe-stop circuit.
- LCD display of the ohmic value of the insulation resistance.
- Fault Memory
- [Info], [Test], and [Reset] keys

Manual motor starters

Provide 3-phase power for electric blowers often required for larger motors. Power for the starters is provided from the load side of any supplied contactor, circuit breaker, or disconnect switch. Power is fused before each motor starter and is off when the incoming power to the frequency converter is off. Up to 2 starters are allowed (only 1 if a 30 A, fuse-protected circuit is ordered). The manual motor starter is integrated into the frequency converter's STO and includes the following features:

- Operation switch (on/off)
- Short-circuit and overload protection with test function
- Manual reset function

30 Amp, fuse-protected terminals

- 3-phase power matching incoming mains voltage for powering auxiliary customer equipment.
- Not available if 2 manual motor starters are selected.
- Terminals are off when the incoming power to the frequency converter is off.
- Power for the fused protected terminals is provided from the load side of any supplied circuit breaker or disconnect switch.

24 V DC power supply

- 5 A, 120 W, 24 V DC
- Protected against output overcurrent, overload, short circuits, and overtemperature.
- For powering 3rd party accessory devices such as sensors, PLC I/O, contactors, temperature probes, indicator lights, and/or other electronic hardware.
- Diagnostics include a dry DC-ok contact, a green DC-ok LED, and a red overload LED.

External temperature monitoring

Designed for monitoring temperatures of external system components, such as the motor windings and/or bearings. Includes 8 universal input modules plus 2 dedicated thermistor input modules. All 10 modules are integrated into the frequency converter's STO circuit and can be monitored via a fieldbus network (requires a separate module/bus coupler).

Universal inputs (8) - signal types

- RTD inputs (including Pt100), 3-wire or 4-wire
- Thermocoupler
- Analog current or analog voltage

Additional features:

- 1 universal output, configurable for analog voltage or analog current.
- 2 output relays (N.O.)
- Dual-line LC display and LED diagnostics
- Sensor lead wire break, short-circuit, and incorrect polarity detection
- Interface set-up software

Dedicated thermistor inputs (2) - features

- Each module is capable of monitoring up to 6 thermistors in series.
- Fault diagnostics for wire breakage or short-circuits of sensor leads.
- ATEX/UL/CSA certification
- A 3rd thermistor input can be provided by the PTC Thermistor Option Card MCB 112, if necessary.

4 How to Install

4.1 Electrical Installation

4.1.1 Power Connections

4

Cabling and Fusing

NOTICE

Cables General

All cabling must comply with national and local regulations on cable cross-sections and ambient temperature. UL applications require 75 °C copper conductors. 75 °C and 90 °C copper conductors are thermally acceptable for the frequency converter to use in non UL applications.

The power cable connections are located as in *Illustration 4.1*. Dimensioning of the cable cross-section must be done in accordance with the current ratings and local legislation. See *chapter 7.1 General Specifications* for details.

For protection of the frequency converter, use the recommended fuses, or ensure that the unit has built-in fuses. Recommended fuses are detailed in in *chapter 4.1.12 Fuses*. Always ensure that fusing conforms to local regulations.

The mains connection is fitted to the mains switch if this is included.

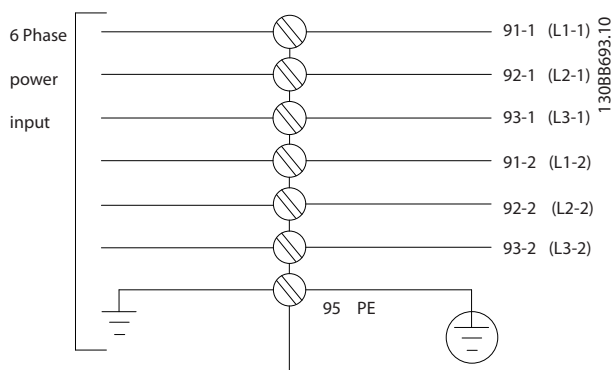

Illustration 4.1 Power Cable Connections

NOTICE

If an unshielded/unarmoured cable is used, some EMC requirements are not complied with. Use a shielded/armoured motor cable to comply with EMC emission specifications. For more information, see *EMC Specifications* in the product relevant *design guide*.

See *chapter 7.1 General Specifications* for the correct dimensioning of the motor cable cross-section and length.

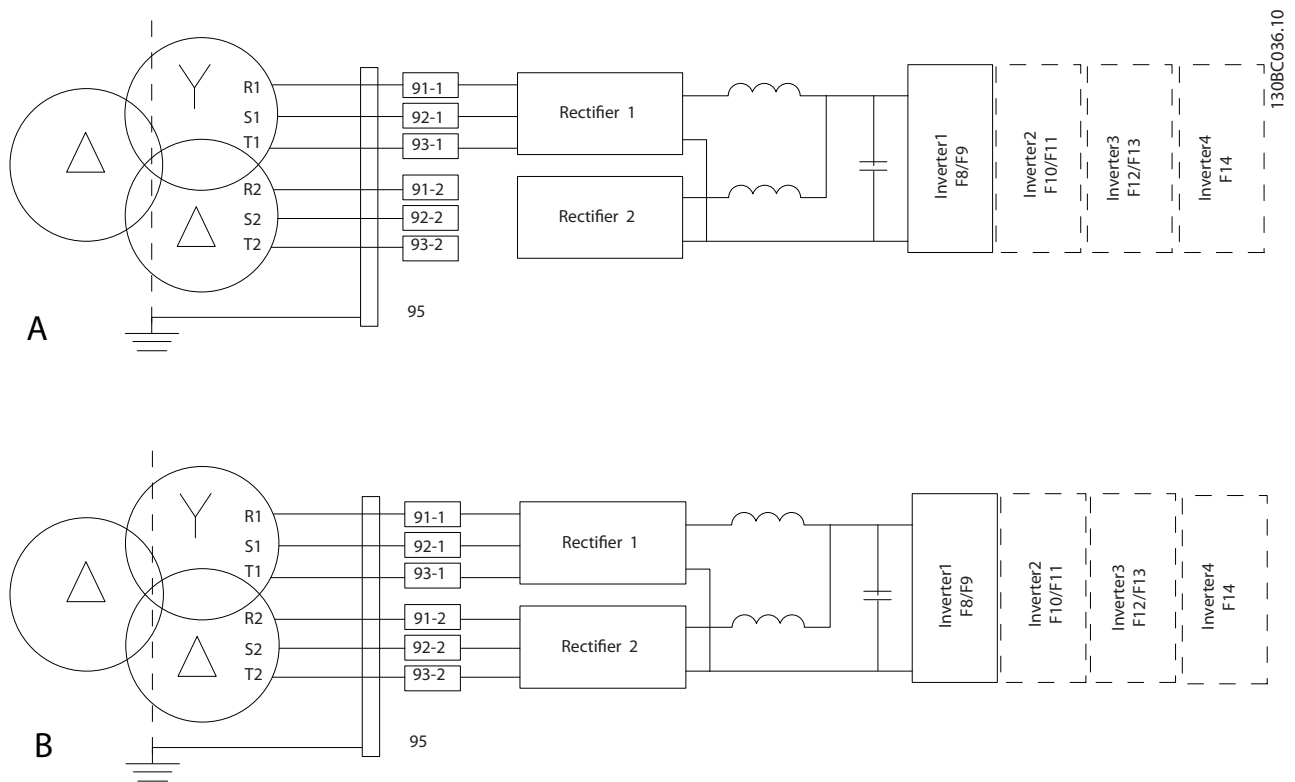

Illustration 4.2 A) Modified 6-Pulse Connection^{1), 2), 3)}
 B) 12-Pulse Connection^{2), 4)}

Notes

- 1) 6-pulse connection eliminates the harmonics reduction benefits of the 12-pulse rectifier.
- 2) Suitable for IT and TN mains connection.
- 3) In the unlikely event that 1 of the 6-pulse modular rectifiers becomes inoperable, it is possible to operate the frequency converter at reduced load with a single 6-pulse rectifier. Contact Danfoss for reconnection details.
- 4) No paralleling of mains cabling is shown here.

Screening of cables

Avoid installation with twisted screen ends (pigtails). They spoil the screening effect at higher frequencies. If it is necessary to break the screen to install a motor isolator or motor contactor, the screen must be continued at the lowest possible HF impedance.

Connect the motor cable screen to both the decoupling plate of the frequency converter and to the metal housing of the motor.

Make the screen connections with the largest possible surface area (cable clamp). This is done by using the supplied installation devices within the frequency converter.

Cable length and cross-section

The frequency converter has been EMC tested with a given cable length. Keep the motor cable as short as possible to reduce the noise level and leakage currents.

Switching frequency

When frequency converters are used with sine-wave filters to reduce the acoustic noise from a motor, set the switching frequency according to the instruction in 14-01 *Switching Frequency*.

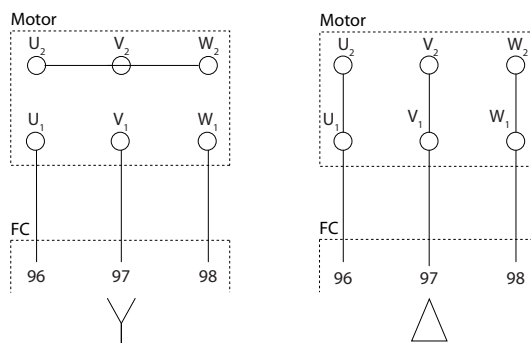

Illustration 4.3 Star and Delta Connections

Term. no.				
96	97	98	99	
U	V	W	PE ¹⁾	Motor voltage 0-100% of mains voltage. 3 wires out of motor
U1	V1	W1	PE ¹⁾	Delta-connected 6 wires out of motor
W2	U2	V2		
U1	V1	W1	PE ¹⁾	Star-connected U2, V2, W2 U2, V2 and W2 to be interconnected separately.

Table 4.1 Terminal Connections

1) Protective Earth Connection

NOTICE

In motors without phase insulation paper or other insulation reinforcement suitable for operation with voltage supply (such as a frequency converter), fit a sine-wave filter on the output of the frequency converter.

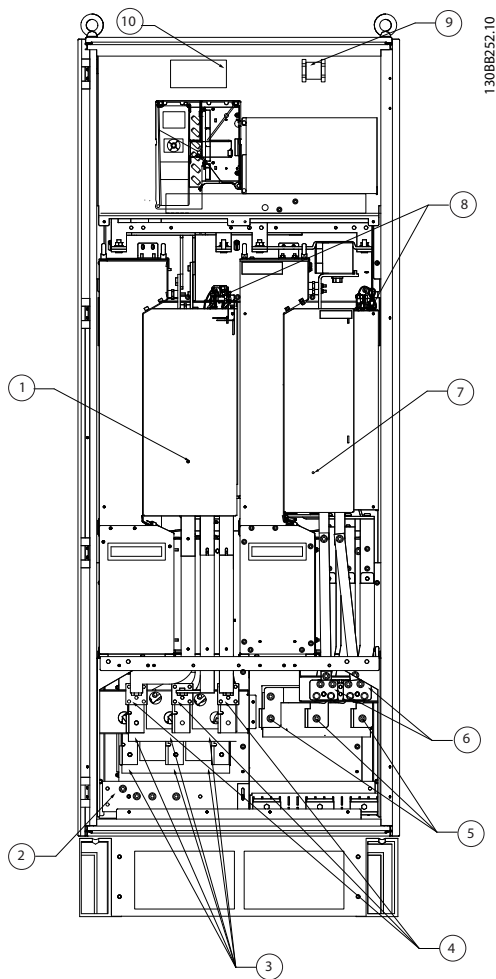

1	12-pulse rectifier module					
2	Ground/earth PE terminals					
3	Mains/fuses					
	R1	S1	T1			
	L1-1	L2-1	L3-1			
4	Mains/fuses					
	R2	S2	T2			
	L2-1	L2-2	L3-2			
5	Motor connection					
	U	V	W			
	T1	T2	T3			
	96	97	98			
6	Brake terminals					
	-R	+R				
	81	82				
7	Inverter module					
8	SCR enable/disable					
9	Relay 1			Relay 2		
	01	02	03	04	05	06
10	Auxillary fan					
	104	106				

Illustration 4.4 Rectifier and Inverter Cabinet, Enclosure Sizes F8 and F9

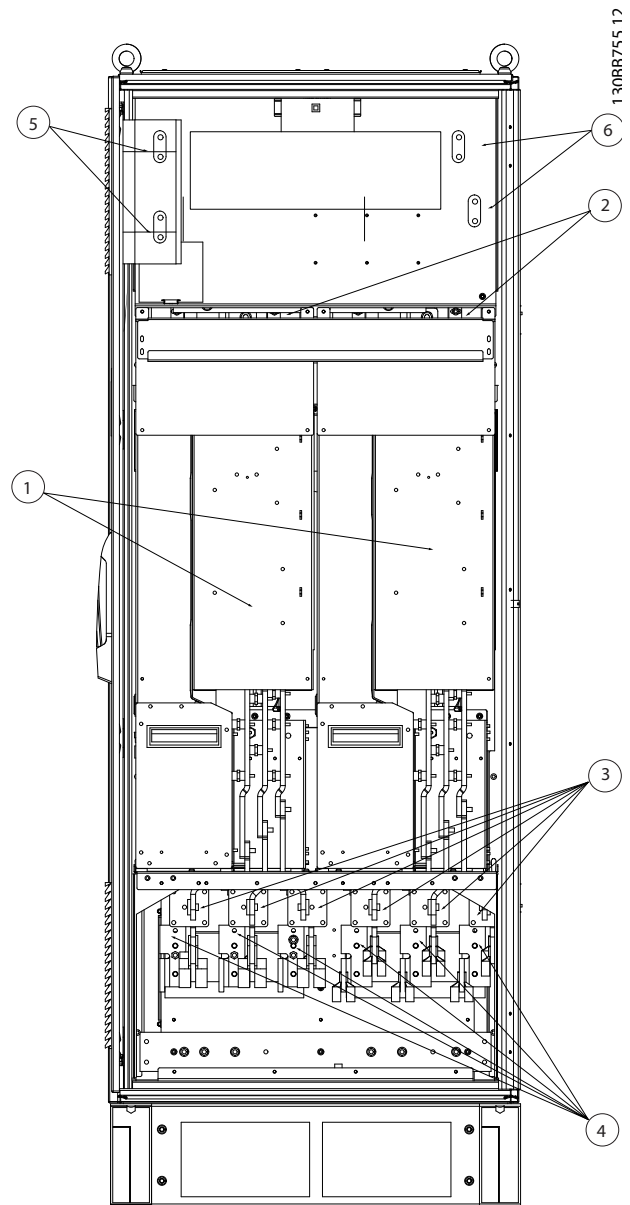

1	12-pulse rectifier module					
2	AUX fan					
	100	101	102	103		
3	Mains fuses F10/F12 (6 pieces)					
	L1	L2	L1	L2		
4	Mains					
	R1	S1	T1	R2	S2	T2
	L1-1	L2-1	L3-1	L1-2	L2-2	L3-2
5	DC bus connections for common DC bus					
	DC+	DC-				
6	DC bus connections for common DC bus					
	DC+	DC-				

Illustration 4.5 Rectifier Cabinet, Enclosure Sizes F10 and F12

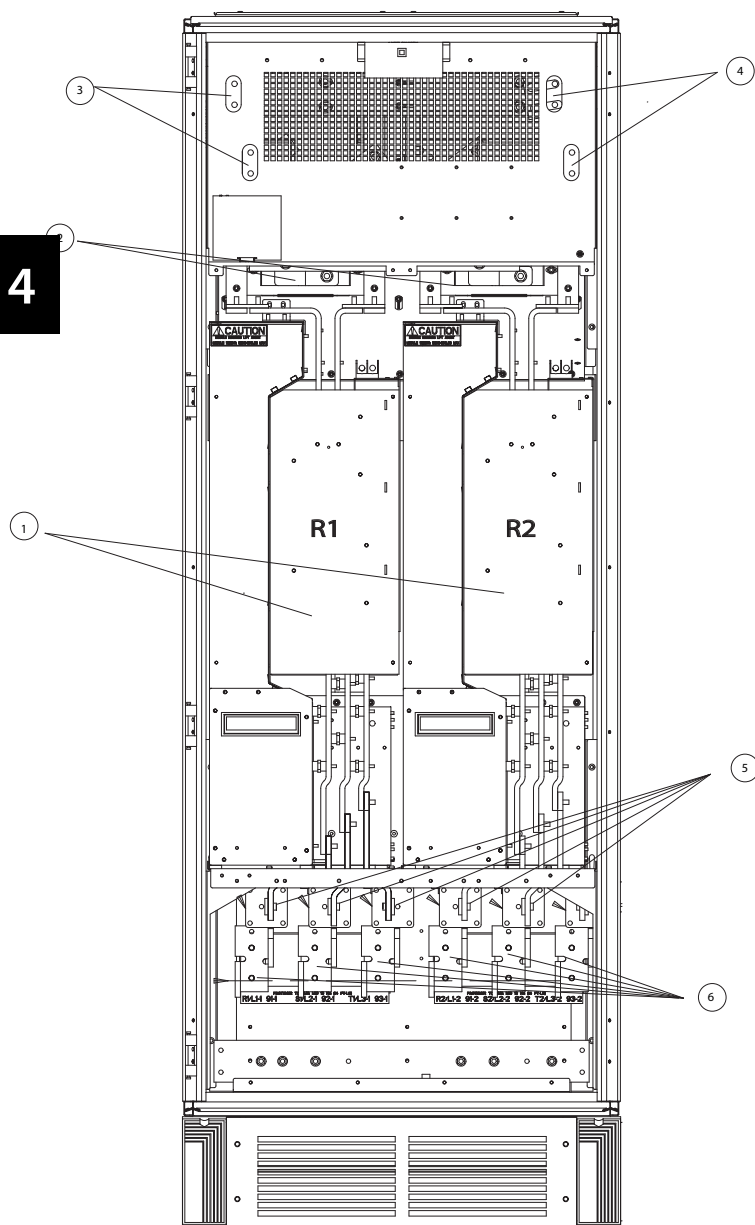

1	12-pulse rectifier modules					
2	N/A					
3	DC busbar access					
4	DC busbar access					
	100	101	102	103		
	L1	L2	L1	L2		
5	Mains fuses (6 pieces)					
	-R	+R				
	81	82				
6	Mains					
	R1	S1	T1	R2	S2	T2
	L1-1	L2-1	L3-1	L1-2	L2-2	L3-2

Illustration 4.6 Rectifier Cabinet, Enclosure Size F14

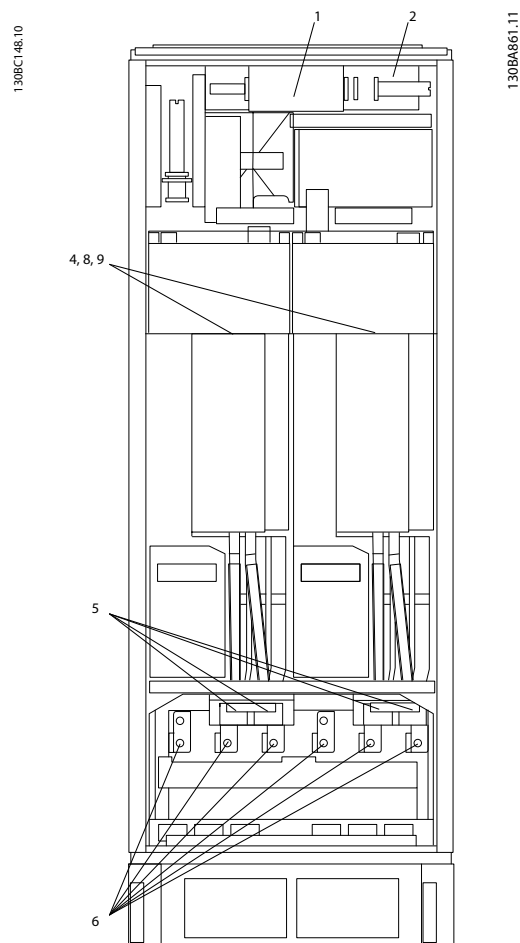

1	External temperature monitoring			
2	AUX relay			
	01	02	03	
	04	05	06	
3	NAMUR			
4	AUX fan			
	100	101	102	103
	L1	L2	L1	L2
5	Brake			
	-R	+R		
	81	82		
6	Motor			
	U	V	W	
	96	97	98	
	T1	T2	T3	
7	NAMUR fuse. See Table 4.16 for part numbers.			
8	Fan fuses. See Table 4.13 for part numbers.			
9	SMPS fuses. See Table 4.12 for part numbers.			

Illustration 4.7 Inverter Cabinet, Enclosure Sizes F10 and F11

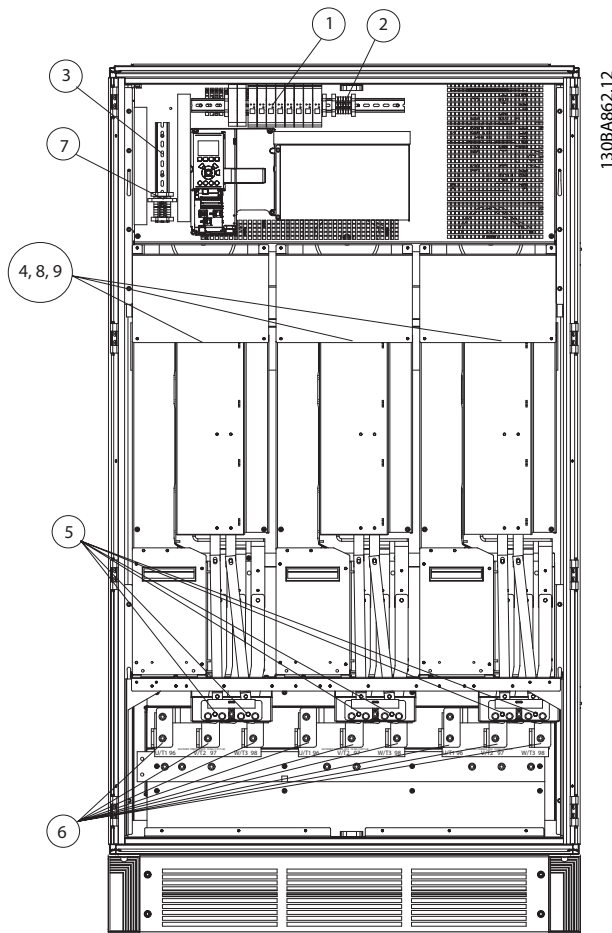

130BA862.12

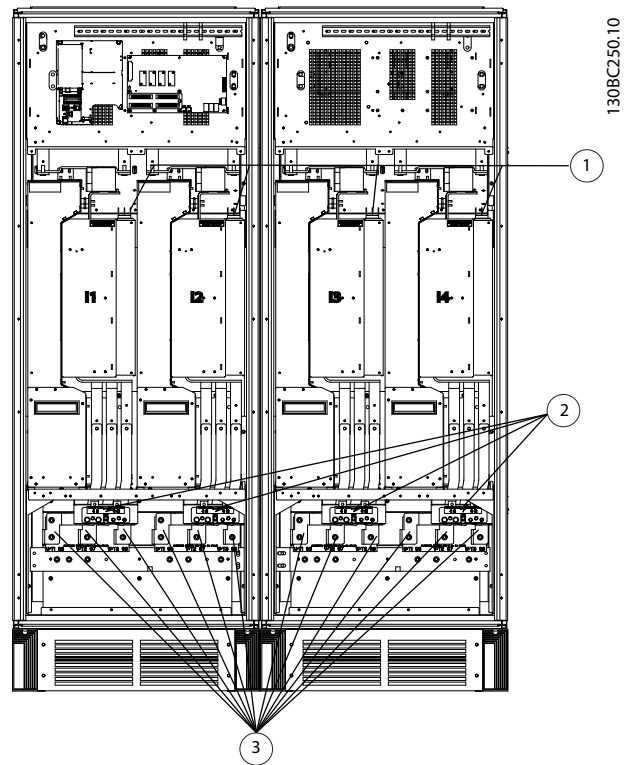

130BC250.10

4

1	External temperature monitoring		
2	AUX relay		
	01	02	03
3	04	05	06
	NAMUR		
4	AUX fan		
	100	101	102
5	L1	L2	L1
	Brake		
6	-R	+R	
	81	82	
7	Motor		
	U	V	W
	96	97	98
	T1	T2	T3
8	NAMUR fuse. See Table 4.16 for part numbers.		
9	Fan fuses. See Table 4.13 for part numbers.		
9	SMPS fuses. See Table 4.12 for part numbers.		

4	AUX fan			
	100	101	102	103
5	L1	L2	L1	L2
	Brake			
6	-R	+R		
	81	82		
7	Motor			
	U	V	W	
	96	97	98	
	T1	T2	T3	

Illustration 4.9 Inverter Cabinet, Enclosure Size F14

Illustration 4.8 Inverter Cabinet, Enclosure Sizes F12 and F13

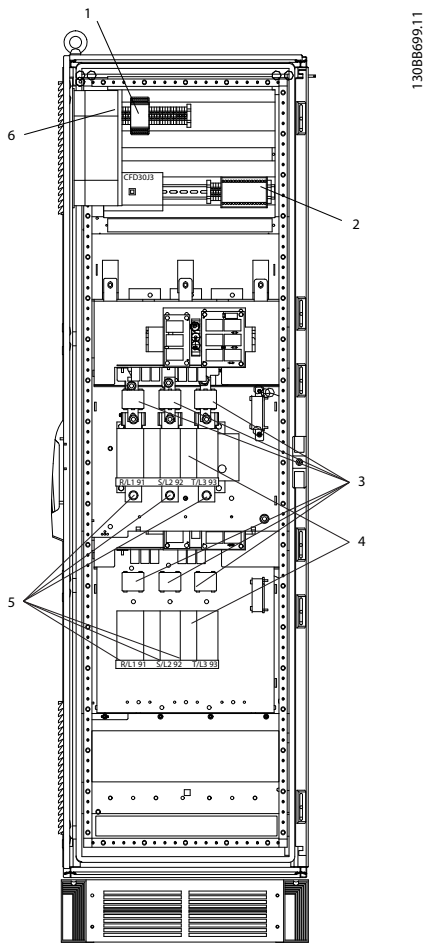

1	Pilz relay terminal					
2	RCD or IRM terminal					
3	Mains/6-phase					
	R1	S1	T1	R2	S2	T2
	91-1	92-1	93-1	91-2	92-2	93-2
	L1-1	L2-1	L3-1	L1-2	L2-2	L3-2
4	Safety relay coil fuse with Pilz relay					
	See chapter 4.1.13 Fuse Tables for part numbers.					
5	Mains fuses, (6 pieces)					
	See chapter 4.1.13 Fuse Tables for part numbers.					
6	2x3-phase manual disconnect					

Illustration 4.10 Options Cabinet, Enclosure Size F9

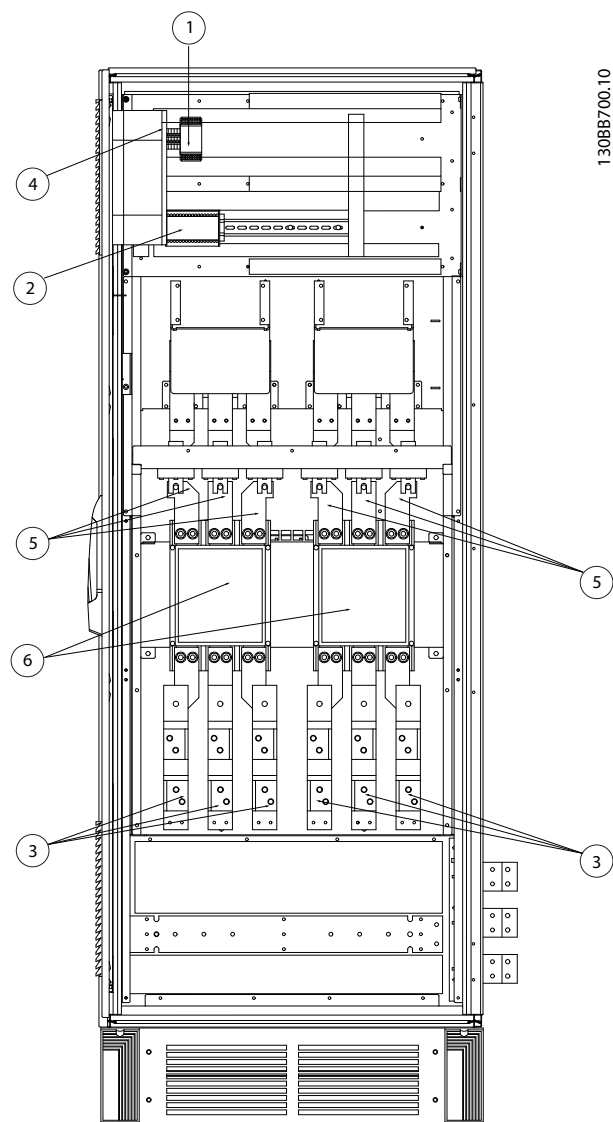

1	Pilz relay terminal					
2	RCD or IRM terminal					
3	Mains/6-phase					
	R1	S1	T1	R2	S2	T2
	91-1	92-1	93-1	91-2	92-2	93-2
	L1-1	L2-1	L3-1	L1-2	L2-2	L3-2
4	Safety relay coil fuse with Pilz relay					
	See chapter 4.1.13 Fuse Tables for part numbers.					
5	Mains fuses, (6 pieces)					
	See chapter 4.1.13 Fuse Tables for part numbers.					
6	2x3-phase manual disconnect					

Illustration 4.11 Options Cabinet, Enclosure Sizes F11 and F13

4.1.2 Grounding

To obtain electromagnetic compatibility (EMC), consider the following basic issues when installing a frequency converter.

- Safety grounding: The frequency converter has a high leakage current (> 3.5 mA) and must be grounded appropriately for safety reasons. Apply local safety regulations.
- High-frequency grounding: Keep the ground wire connections as short as possible.

Connect the different ground systems at the lowest possible conductor impedance. This is obtained by keeping the conductor as short as possible and by using the greatest possible surface area.

The metal cabinets of the different devices are mounted on the cabinet rear plate using the lowest possible High-frequency impedance. This avoids having different High-frequency voltages for the individual devices and avoids the risk of radio interference currents running in any connection cables used between the devices. The radio interference has been reduced.

To obtain a low High-frequency impedance, use the fastening bolts of the devices as High-frequency connection to the rear plate. Remove any insulating paint or similar from the fastening points.

4.1.3 Extra Protection (RCD)

If local safety regulations are complied with, ELCB relays, multiple protective earthing or grounding can be used as extra protection.

A ground fault may cause a DC component to develop in the fault current.

If ELCB relays are used, observe local regulations. Relays must be suitable for the protection of 3-phase equipment with a bridge rectifier and for a brief discharge on power-up.

See also *Special Conditions* in the product relevant *design guide*.

4.1.4 RFI Switch

Mains supply isolated from ground

Turn off (OFF)¹⁾ the RFI switch via *14-50 RFI Filter* on the frequency converter and *14-50 RFI Filter* on the filter if:

- The frequency converter is supplied from an isolated mains source (IT mains, floating delta and grounded delta).
- The frequency converter is supplied from TT/TN-S mains with grounded leg.

For further reference, see IEC 364-3.

Set *14-50 RFI Filter* to [ON] if:

- Optimum EMC performance is needed.
- Parallel motors are connected.
- The motor cable length is above 25 m.

¹⁾ Not available for 525-600/690 V frequency converters.

In OFF, the internal RFI capacities (filter capacitors) between the chassis and the intermediate circuit are cut off to avoid damage to the intermediate circuit and to reduce the ground capacity currents (according to IEC 61800-3).

Also refer to the application note *VLT on IT mains*. It is important to use isolation monitors which are compatible with power electronics (IEC 61557-8).

4.1.5 Torque

When tightening all electrical connections, it is important to tighten with the correct torque. Too low or too high torque results in a poor electrical connection. Use a torque wrench to ensure correct torque.

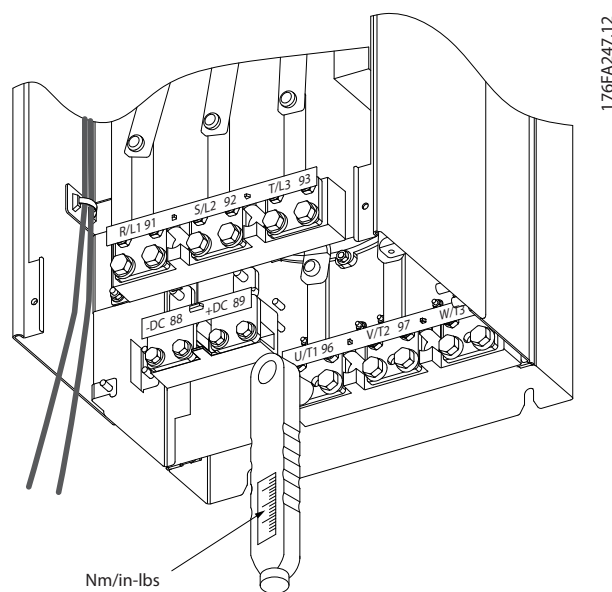

Illustration 4.12 Tightening Torques.

Enclosure size	Terminal	Torque	Bolt size
F8-F14	Mains Motor	19-40 Nm (168-354 in-lbs)	M10
	Brake Regen	8.5-20.5 Nm (75-181 in-lbs)	M8

Table 4.2 Tightening Torques

4.1.6 Screened Cables

WARNING

Danfoss recommends using screened cables between the LCL filter and the frequency converter. Unshielded cables can be used between transformer and LCL filter input side.

4

It is important that screened and armoured cables are connected in a proper way to ensure high EMC immunity and low emissions.

The connection can be made using either cable glands or clamps.

- EMC cable glands: Available cable glands can be used to ensure an optimum EMC connection.
- EMC cable clamp: Clamps allowing easy connection are supplied with the frequency converter.

4.1.7 Motor Cable

Connect the motor to terminals U/T1/96, V/T2/97, W/T3/98. Ground to terminal 99. All types of 3-phase asynchronous standard motors can be used with a frequency converter. The factory setting is for clockwise rotation with the frequency converter output connected as follows:

Terminal Number	Function
96, 97, 98	Mains U/T1, V/T2, W/T3
99	Ground

Table 4.3 Motor Connection Terminals

- Terminal U/T1/96 connected to U-phase.
- Terminal V/T2/97 connected to V-phase.
- Terminal W/T3/98 connected to W-phase.

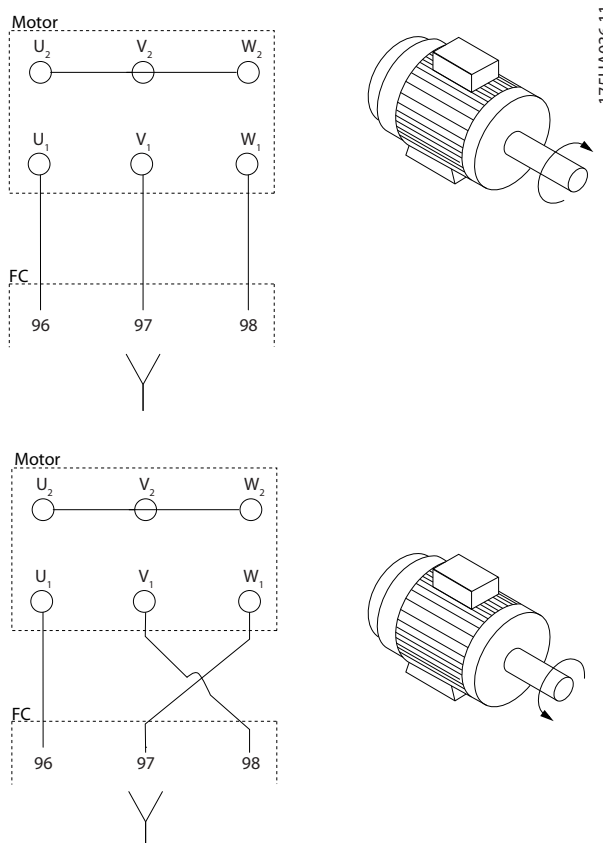

Illustration 4.13 Wiring for Clockwise and Counterclockwise Motor Rotation

The direction of rotation can be changed by switching 2 phases in the motor cable or by changing the setting of 4-10 Motor Speed Direction.

A motor rotation check can be performed using 1-28 Motor Rotation Check and following the steps shown on the display.

Requirements

F8/F9 requirements: The cables must be of equal length within 10% between the inverter module terminals and the first common point of a phase. The recommended common point is the motor terminals.

F10/F11 requirements: Motor phase cable quantities must be multiples of 2, resulting in 2, 4, 6, or 8 (1 cable is not allowed) to obtain equal amount of wires attached to both inverter module terminals. The cables must be equal length within 10% between the inverter module terminals and the first common point of a phase. The recommended common point is the motor terminals.

F12/F13 requirements: Motor phase cable quantities must be multiples of 3, resulting in 3, 6, 9, or 12 (1, 2, or 3 cables are not allowed) to obtain an equal amount of wires attached to each inverter module terminal. The wires must be of equal length within 10% between the inverter

module terminals and the first common point of a phase. The recommended common point is the motor terminals.

F14 requirements: Motor phase cable quantities must be multiples of 4, resulting in 4, 8, 12, or 16 (1, 2, or 3 cables are not allowed) to obtain an equal amount of wires attached to each inverter module terminal. The wires must be of equal length within 10% between the inverter module terminals and the first common point of a phase. The recommended common point is the motor terminals.

Output junction box requirements: The length, minimum 2.5 m, and quantity of cables must be equal from each inverter module to the common terminal in the junction box.

NOTICE

If a retrofit application requires an unequal amount of wires per phase, consult Danfoss for requirements and documentation, or use the top/bottom entry side cabinet option.

4.1.8 Brake Cable for Frequency Converters with Factory-installed Brake Chopper Option

(Only standard with letter B in position 18 of product type code).

Use a screened connection cable to the brake resistor. The maximum length from the frequency converter to the DC bar is limited to 25 m (82 ft).

Terminal number	Function
81, 82	Brake resistor terminals

Table 4.4 Brake Resistor Terminals

The connection cable to the brake resistor must be screened. Connect the screen to the conductive back plate on the frequency converter and to the metal cabinet of the brake resistor with cable clamps.

Size the brake cable cross-section to match the brake torque. See also the Instructions *Brake Resistor* and *Brake Resistors for Horizontal Applications* for further information regarding safe installation.

NOTICE

Depending on the supply voltage, voltages up to 1099 V DC may occur on the terminals.

F enclosure requirements

Connect the brake resistor to the brake terminals in each inverter module.

4.1.9 Shielding against Electrical Noise

Before mounting the mains power cable, mount the EMC metal cover to ensure best EMC performance.

NOTICE

The EMC metal cover is only included in frequency converters with an RFI filter.

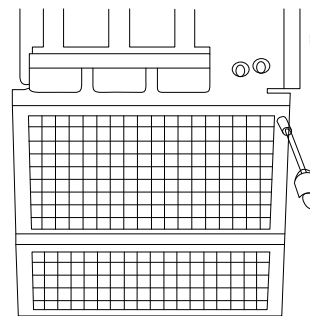

Illustration 4.14 Mounting of EMC shield.

4.1.10 Mains Connection

Mains and ground must be connected as detailed in Table 4.5.

Terminal number	Function
91-1, 92-1, 93-1	Mains R1/L1-1, S1/L2-1, T1/L3-1
91-2, 92-2, 93-2	Mains R2/L1-2, S2/L2-2, T2/L3-2
94	Ground

Table 4.5 Mains and Ground Connection Terminals

NOTICE

Check the nameplate to ensure that the mains voltage of the frequency converter matches the power supply of the plant.

Ensure that the power supply can supply the necessary current to the frequency converter.

If the frequency converter is without built-in fuses, ensure that the appropriate fuses have the correct current rating.

4.1.11 External Fan Supply

In case the frequency converter is supplied by DC, or if the fan must run independently of the power supply, an external power supply can be applied. The connection is made on the power card.

Terminal number	Function
100, 101	Auxiliary supply S, T
102, 103	Internal supply S, T

Table 4.6 External Fan Supply Terminals

The connector located on the power card provides the connection of line voltage for the cooling fans. The fans are connected from factory to be supplied from a common AC line (jumpers between 100-102 and 101-103). If an external supply is needed, remove the jumpers and connect the supply to terminals 100 and 101. Use a 5 A fuse for protection. In UL applications this should be LittleFuse KLK-5 or equivalent.

4.1.12 Fuses

Branch circuit protection

To protect the installation against electrical and fire hazard, all branch circuits in an installation, switch gear, machines etc., must be short-circuited and overcurrent protected according to national/international regulations.

Short-circuit protection

Protect the frequency converter against short-circuit to avoid electrical or fire hazard. Danfoss recommends using the fuses mentioned in to *Table 4.18* to protect service personnel and equipment in case of an internal failure in the frequency converter. The frequency converter provides full short-circuit protection in case of a short-circuit on the motor output.

Overcurrent protection

Provide overload protection to avoid fire hazard due to overheating of the cables in the installation. The frequency converter is equipped with an internal overcurrent protection, which can be used for upstream overload protection (UL-applications excluded). See *4-18 Current Limit*. Moreover, fuses or circuit breakers can be used to provide the overcurrent protection in the installation. Overcurrent protection must always be carried out according to national regulations.

UL compliance

The fuses in this section are suitable for use on a circuit capable of delivering 100000 A_{rms} (symmetrical), 240 V, or 480 V, or 500V, or 600 V depending on the frequency converter voltage rating. With the proper fusing the frequency converter Short Circuit Current Rating (SCCR) is 100000 A_{rms}.

Power size	Enclosure Size	Rating		Bussmann P/N	Spare Bussmann P/N	Estimated fuse power loss [W]	
		Voltage (UL)	Amperes			400V	460V
P315T5	F8/F9	700	700	170M4017	176F9179	25	19
P355T5	F8/F9	700	700	170M4017	176F9179	30	22
P400T5	F8/F9	700	700	170M4017	176F9179	38	29
P450T5	F8/F9	700	700	170M4017	176F9179	3500	2800
P500T5	F10/F11	700	900	170M6013	176F9180	3940	4925
P560T5	F10/F11	700	900	170M6013	176F9180	2625	2100
P630T5	F10/F11	700	900	170M6013	176F9180	3940	4925
P710T5	F10/F11	700	1500	170M6018	176F9181	45	34
P800T5	F12/F13	700	1500	170M6018	176F9181	60	45
P1M0T5	F12/F13	700	1500	170M6018	176F9181	83	63

Table 4.7 Mains Fuses, 380-500 V

Power size	Enclosure	Rating		Bussmann	Spare Bussmann	Estimated fuse power loss [W]	
		Size	Voltage (UL)	Amperes	P/N	P/N	600V
P450T7	F8/F9	700	630	170M4016	176F9179	13	10
P500T7	F8/F9	700	630	170M4016	176F9179	17	13
P560T7	F8/F9	700	630	170M4016	176F9179	22	16
P630T7	F8/F9	700	630	170M4016	176F9179	24	18
P710T7	F10/F11	700	900	170M6013	176F9180	26	20
P800T7	F10/F11	700	900	170M6013	176F9180	35	27
P900T7	F10/F11	700	900	170M6013	176F9180	44	33
P1M0T7	F12/F13	700	1500	170M6018	176F9181	26	20
P1M2T7	F12/F13	700	1500	170M6018	176F9181	37	28
P1M4T7	F12/F13	700	1500	170M6018	176F9181	47	36

Table 4.8 Mains Fuses, 525-690 V

Size/Type	Bussmann PN*	Rating	Siba
P500	170M8611	1100 A, 1000 V	20 781 32.1000
P560	170M8611	1100 A, 1000 V	20 781 32.1000
P630	170M6467	1400 A, 700 V	20 681 32.1400
P710	170M6467	1400 A, 700 V	20 681 32.1400
P800	170M8611	1100 A, 1000 V	20 781 32.1000
P1M0	170M6467	1400 A, 700 V	20 681 32.1400

Table 4.9 Inverter module DC Link Fuses, 380-500V

Size/Type	Bussmann PN*	Rating	Siba
P710	170M8611	1100 A, 1000 V	20 781 32. 1000
P800	170M8611	1100 A, 1000 V	20 781 32. 1000
P900	170M8611	1100 A, 1000 V	20 781 32. 1000
P1M0	170M8611	1100 A, 1000 V	20 781 32. 1000
P1M2	170M8611	1100 A, 1000 V	20 781 32. 1000
P1M4	170M8611	1100A, 1000V	20 781 32.1000

Table 4.10 Inverter module DC Link Fuses, 525-690V

*170M fuses from Bussmann shown use the -/80 visual indicator, - TN/80 Type T, -/110 or TN/110 Type T indicator fuses of the same size and amperage may be substituted for external use.

Supplementary fuses

	Size/Type	Bussmann PN*	Rating	Alternative Fuses
2.5-4.0 A Fuse	P500-P1M0, 380-500 V	LPJ-6 SP or SPI	6 A, 600 V	Any listed Class J Dual Element, Time Delay, 6A
	P710-P1M4, 525-690 V	LPJ-10 SP or SPI	10 A, 600 V	Any listed Class J Dual Element, Time Delay, 10 A
4.0-6.3 A Fuse	P500-P1M0, 380-500 V	LPJ-10 SP or SPI	10 A, 600 V	Any listed Class J Dual Element, Time Delay, 10 A
	P710-P1M4, 525-690 V	LPJ-15 SP or SPI	15 A, 600 V	Any listed Class J Dual Element, Time Delay, 15 A
6.3 - 10 A Fuse	P500-P1M0, 380-500 V	LPJ-15 SP or SPI	15 A, 600 V	Any listed Class J Dual Element, Time Delay, 15 A
	P710-P1M4, 525-690 V	LPJ-20 SP or SPI	20 A, 600 V	Any listed Class J Dual Element, Time Delay, 20A
10 - 16 A Fuse	P500-P1M0, 380-500 V	LPJ-25 SP or SPI	25 A, 600 V	Any listed Class J Dual Element, Time Delay, 25 A
	P710-P1M4, 525-690 V	LPJ-20 SP or SPI	20 A, 600 V	Any listed Class J Dual Element, Time Delay, 20 A

Table 4.11 Manual Motor Controller Fuses

Enclosure size	Bussmann PN*	Rating
F8-F13	KTK-4	4 A, 600V

Table 4.12 SMPS Fuse

Size/Type	Bussmann PN*	Littelfuse	Rating
P355-P1M0, 380-500 V		KLK-15	15A, 600V
P450-P1M4, 525-690 V		KLK-15	15A, 600V

Table 4.13 Fan Fuses

Enclosure size	Bussmann PN*	Rating	Alternative fuses
F8-F13	LPJ-30 SP or SPI	30 A, 600 V	Any listed Class J Dual Element, Time Delay, 30 A

Table 4.14 30 A Fuse Protected Terminal Fuse

Enclosure size	Bussmann PN*	Rating	Alternative fuses
F8-F13	LPJ-6 SP or SPI	6 A, 600 V	Any listed Class J Dual Element, Time Delay, 6 A

Table 4.15 Control Transformer Fuse

Enclosure size	Bussmann PN*	Rating
F8-F13	GMC-800MA	800mA, 250V

Table 4.16 NAMUR Fuse

Frame size	Bussmann PN*	Rating	Alternative fuses
F8-F13	LP-CC-6	6A, 600V	Any listed Class CC, 6A

Table 4.17 Safety Relay Coil Fuse with PILS Relay

Enclosure size	Power	Type
380-500 V		
F9	P250	ABB OETL-NF600A
F9	P315	ABB OETL-NF600A
F9	P355	ABB OETL-NF600A
F9	P400	ABB OETL-NF600A
F11	P450	ABB OETL-NF800A
F11	P500	ABB OETL-NF800A
F11	P560	ABB OETL-NF800A
F11	P630	ABB OT800U21
F13	P710	Merlin Gerin NPJF36000S12AAYP
F13	P800	Merlin Gerin NPJF36000S12AAYP
525-690 V		
F9	P355	ABB OT400U12-121
F9	P400	ABB OT400U12-121
F9	P500	ABB OT400U12-121
F9	P560	ABB OT400U12-121
F11	P630	ABB OETL-NF600A
F11	P710	ABB OETL-NF600A
F11	P800	ABB OT800U21
F13	P900	ABB OT800U21
F13	P1M0	Merlin Gerin NPJF36000S12AAYP
F13	P1M2	Merlin Gerin NPJF36000S12AAYP

Table 4.18 Mains Disconnectors

4.1.13 Motor Insulation

For motor cable lengths \leq the maximum cable length listed in , the motor insulation ratings in *Table 4.19* are recommended. Peak voltage can be up to twice the DC-link voltage, and 2.8 times the mains voltage, due to transmission line effects in the motor cable. If a motor has lower insulation rating, use a dU/dt or sine-wave filter.

Nominal mains voltage [V]	Motor insulation [V]
$U_N \leq 420$	Standard $U_{LL}=1300$
$420 < U_N \leq 500$	Reinforced $U_{LL}=1600$
$500 < U_N \leq 600$	Reinforced $U_{LL}=1800$
$600 < U_N \leq 690$	Reinforced $U_{LL}=2000$

Table 4.19 Motor Insulation Ratings

4.1.14 Motor Bearing Currents

All motors installed with FC 202 315kW or higher power drives should have NDE (Non-Drive End) insulated bearings installed to eliminate circulating bearing currents. To minimize DE (Drive End) bearing and shaft currents proper grounding of the drive, motor, driven machine, and motor to the driven machine is required.

Standard Mitigation Strategies:

1. Use an insulated bearing
2. Apply rigorous installation procedures
 - Ensure the motor and load motor are aligned
 - Strictly follow the EMC Installation guideline
 - Reinforce the PE so the high frequency impedance is lower in the PE than the input power leads
 - Provide a good high frequency connection between the motor and the frequency converter for instance by screened cable which has a 360° connection in the motor and the frequency converter
 - Make sure that the impedance from frequency converter to building ground is lower than the grounding impedance of the machine. This can be difficult for pumps
 - Make a direct earth connection between the motor and load motor
3. Lower the IGBT switching frequency
4. Modify the inverter waveform, 60° AVVM vs. SFAVM

5. Install a shaft grounding system or use an isolating coupling
6. Apply conductive lubrication
7. Use minimum speed settings if possible
8. Try to ensure the line voltage is balanced to ground. This can be difficult for IT, TT, TN-CS or Grounded leg systems
9. Use a dU/dt or sinus filter

4.1.15 Brake Resistor Temperature Switch

- Torque: 0.5-0.6 Nm (5 in-lbs)
- Screw size: M3

This input can be used to monitor the temperature of an externally connected brake resistor. If the input between 104 and 106 is established, the frequency converter trips on warning/alarm 27 *Brake IGBT*. If the connection is closed between 104 and 105, the frequency converter trips on warning/alarm 27 *Brake IGBT*.

Install a KLIXON switch that is normally closed. If this function is not used, short-circuit 106 and 104 together.

- Normally closed: 104-106 (factory installed jumper)
- Normally open: 104-105

Terminal number	Function
106, 104, 105	Brake resistor temperature switch.

Table 4.20 Brake Resistor Temperature Switch Terminals

CAUTION

If the temperature of the brake resistor gets too high and the thermal switch drops out, the frequency converter stops braking and the motor starts coasting.

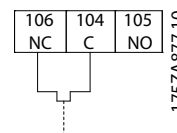

Illustration 4.15 Brake Resistor Temperature Switch

4.1.16 Control Cable Routing

Tie all control wires down to the designated control cable routing. Remember to connect the shields in a proper way to ensure optimum electrical immunity.

Fieldbus connection

Connections are made to the relevant options on the control card. For details, see the relevant fieldbus instruction. Place the cable in the provided path inside the

frequency converter and tie it down with other control wires.

Installation of 24 V external DC supply

- Torque: 0.5 - 0.6 Nm (5 in-lbs)
- Screw size: M3

Terminal number	Function
35 (-), 36 (+)	24 V external DC supply

Table 4.21 Terminals for 24 V External DC Supply

24 V DC external supply can be used as low-voltage supply to the control card and any option cards installed. This enables full operation of the LCP (including parameter setting) without connection to the mains. A warning of low voltage is given when 24 V DC has been connected; however, there is no tripping.

NOTICE

Use 24 V DC PELV supply to ensure correct galvanic isolation (type PELV) on the control terminals of the frequency converter.

4.1.17 Access to Control Terminals

All terminals to the control cables are located beneath the LCP. They are accessed by opening the door of the IP21/ IP54 unit, or by removing the covers of the IP00 unit.

4.1.18 Electrical Installation, Control Terminals

To connect the cable to the terminal:

1. Strip the insulation by about 9–10 mm

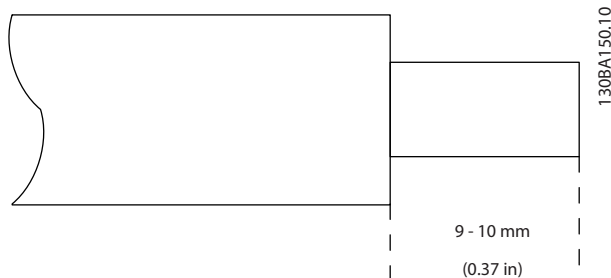

Illustration 4.16 Stripping of Insulation

2. Insert a screwdriver¹⁾ in the square hole.
3. Insert the cable in the adjacent circular hole.

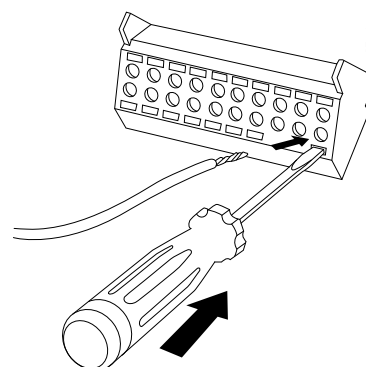

Illustration 4.17 Inserting Cable

4. Remove the screwdriver. The cable is now mounted in the terminal.

1) Maximum 0.4x2.5 mm

To remove the cable from the terminal:

1. Insert a screwdriver¹⁾ in the square hole.
2. Pull out the cable.

1) Max. 0.4x2.5 mm

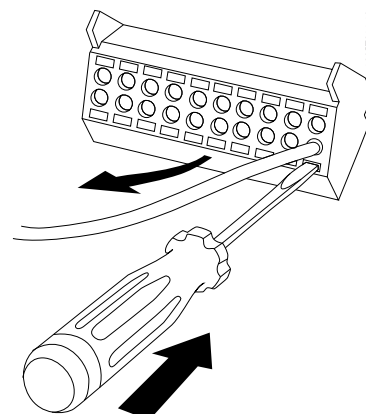

Illustration 4.18 Removing Cable

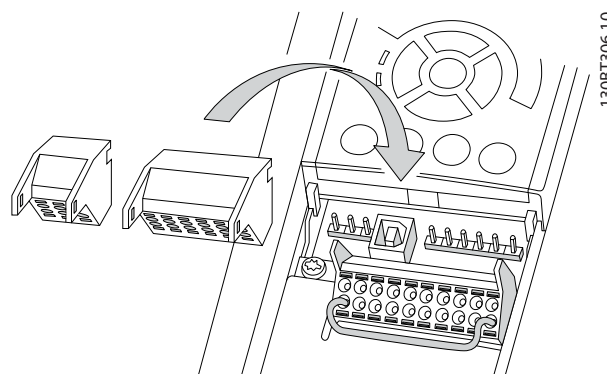

Illustration 4.19 Unplugging Control Terminals

4.2 Connection Examples

4.2.1 Start/Stop

Terminal 18 = 5-10 Terminal 18 Digital Input [8] Start

Terminal 27 = 5-12 Terminal 27 Digital Input [0] No operation (Default coast inverse)

Terminal 37 = Safe Torque Off

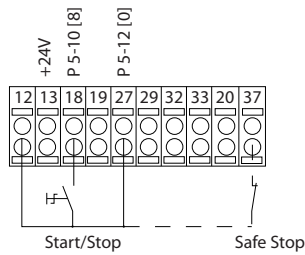

130BA155.12

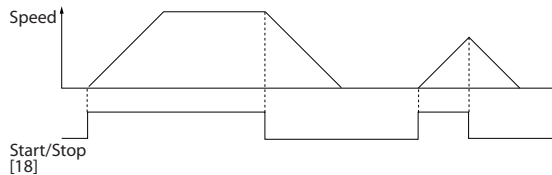

Illustration 4.20 Wiring Start/Stop

4.2.2 Pulse Start/Stop

Terminal 18 = 5-10 Terminal 18 Digital Input [9] Latched start

Terminal 27 = 5-12 Terminal 27 Digital Input [6] Stop inverse

Terminal 37 = Safe Torque Off

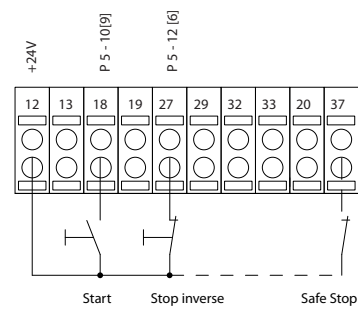

130BA156.12

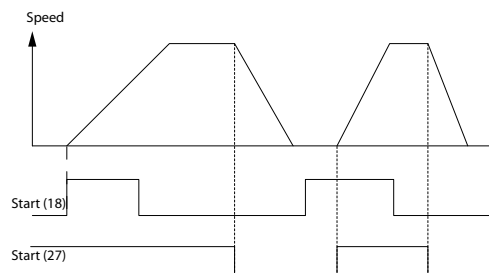

Illustration 4.21 Wiring Pulse Start/Stop

4.2.3 Speed Up/Down

Terminals 29/32 = Speed up/down

Terminal 18 = 5-10 Terminal 18 Digital Input [9] Start (default)

Terminal 27 = 5-12 Terminal 27 Digital Input [19] Freeze reference

Terminal 29 = 5-13 Terminal 29 Digital Input [21] Speed up

Terminal 32 = 5-14 Terminal 32 Digital Input [22] Speed down

NOTICE

Terminal 29 only in FC x02 (x=series type).

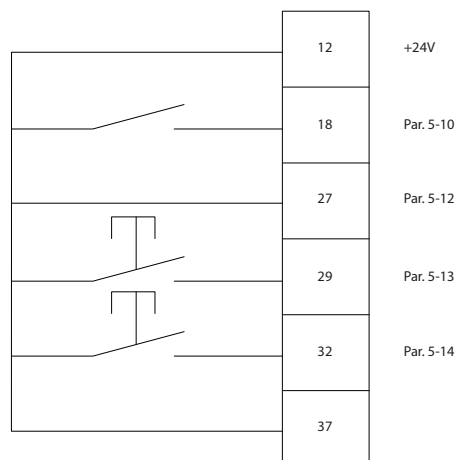

130BA021.12

Illustration 4.22 Speed Up/Down

4.2.4 Potentiometer Reference

Voltage reference via a potentiometer

Reference Source 1 = [1] Analog input 53 (default)

Terminal 53, Low Voltage = 0 V

Terminal 53, High Voltage = 10 V

Terminal 53, Low Ref./Feedback = 0 RPM

Terminal 53, High Ref./Feedback = 1500 RPM

Switch S201 = OFF (U)

4

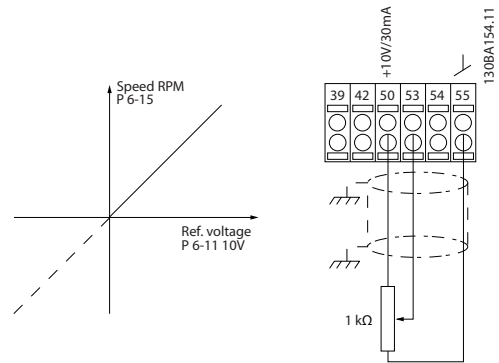

Illustration 4.23 Potentiometer Reference

4.3 Electrical Installation - additional

4.3.1 Electrical Installation, Control Cables

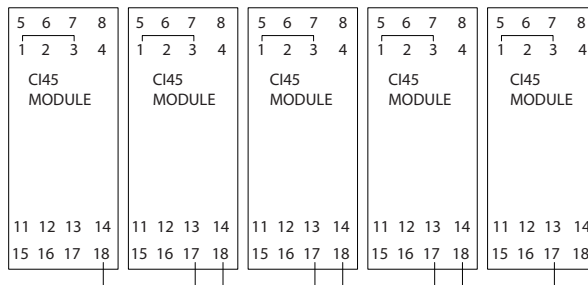
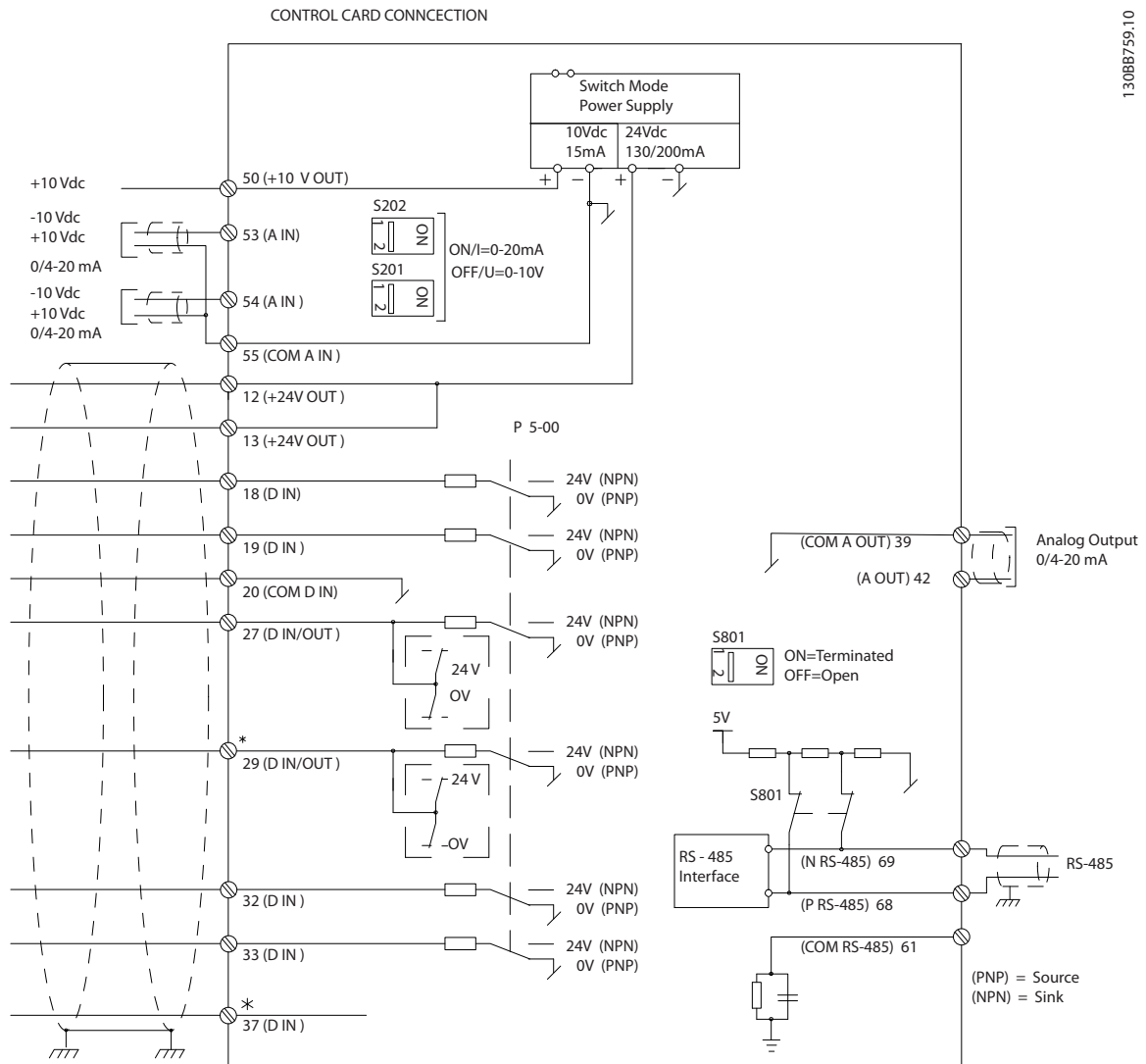
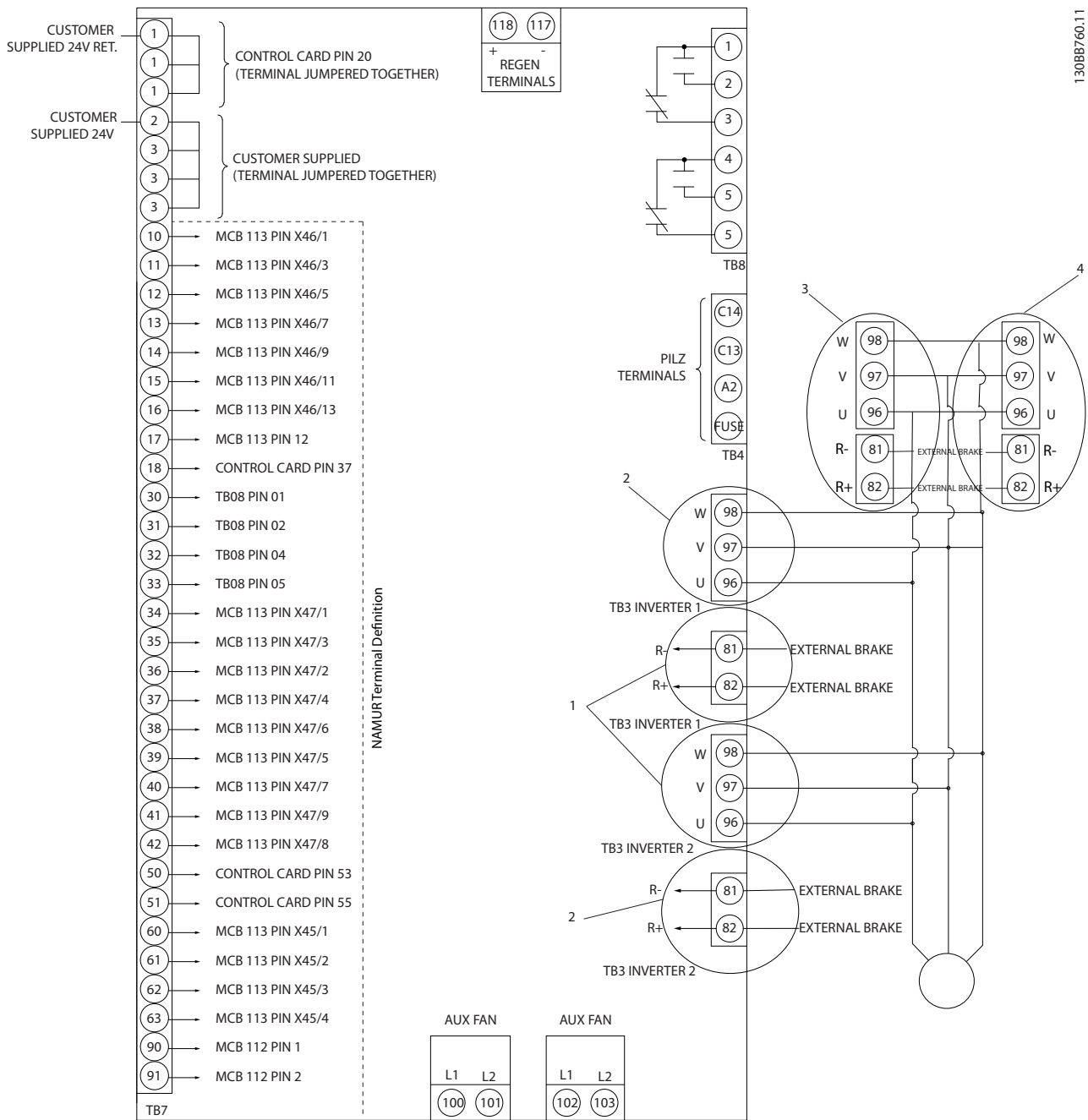

Illustration 4.24

A=Analog, D=Digital

*Terminal 37 (optional) is used for Safe Torque Off. For Safe Torque Off installation instructions, refer to the *Safe Torque Off Operating Instructions for Danfoss VLT® Frequency Converters*.

**Do not connect cable screen.



130BB760.11

Illustration 4.25 Diagram Showing all Electrical Terminals with NAMUR Option

Very long control cables and analog signals may in rare cases and depending on installation result in 50/60 Hz ground loops due to noise from mains supply cables.

If this occurs, it may be necessary to break the screen or insert a 100 nF capacitor between screen and chassis.

Connect the digital and analog inputs and outputs separately to the frequency converter common inputs (terminal 20, 55, 39) to avoid ground currents from both groups to affect other groups. For example, switching on the digital input may disturb the analog input signal.

Input polarity of control terminals

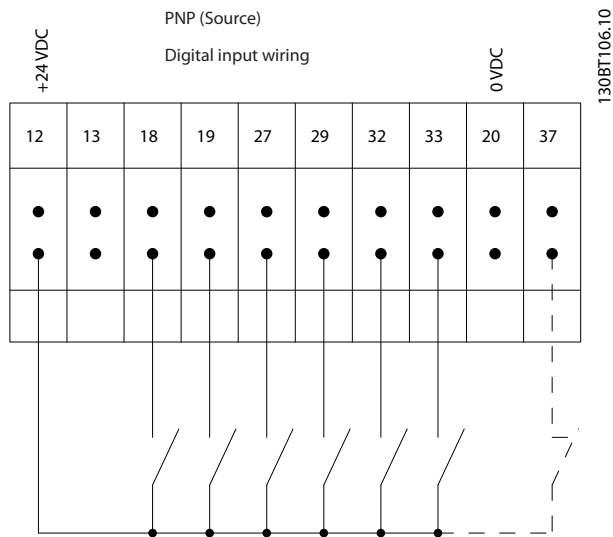

Illustration 4.26 PNP (Source)

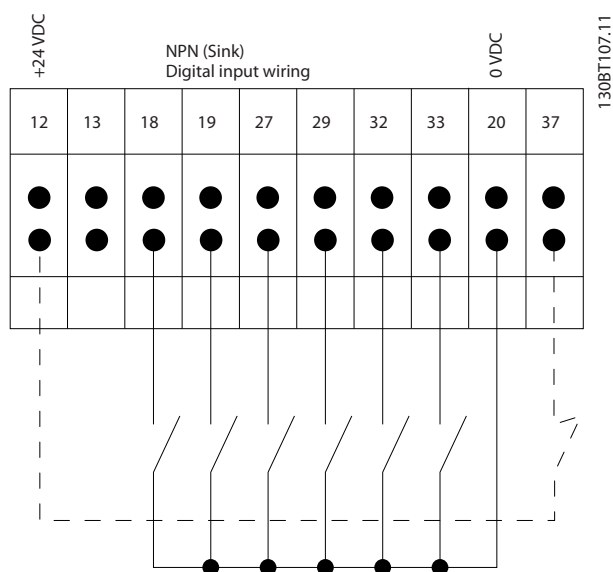

Illustration 4.27 NPN (Sink)

NOTICE

Control cables must be screened/armoured.

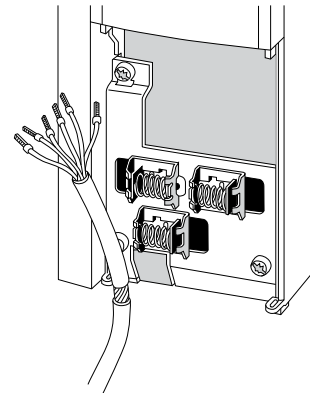

Illustration 4.28 Grounding of Screened/Armoured Control Cables

Connect the wires as described in the product related *Operating Instructions*. Remember to connect the shields in a proper way to ensure optimum electrical immunity.

4.3.2 Switches S201, S202 and S801

Use switches S201 (A53) and S202 (A54) to configure the analog input terminals 53 and 54 as a current (0–20 mA) or a voltage (-10 V to +10 V).

Enable termination on the RS-485 port (terminals 68 and 69) via the switch S801 (BUS TER.).

See *Illustration 4.24*.

Default setting:

- S201 (A53) = OFF (voltage input)
- S202 (A54) = OFF (voltage input)
- S801 (Bus termination) = OFF

NOTICE

When changing the function of S201, S202, or S801 do not to use force during the switch over. Remove the LCP fixture (cradle) when operating the switches. Do not operate the switches when the frequency converter is powered.

4

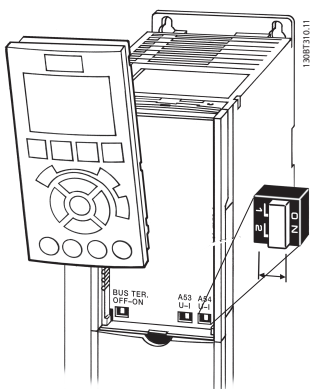

Illustration 4.29 Switch Location

4.4 Final Set-up and Test

To test the set-up and to ensure that the frequency converter is running, follow these steps.

Step 1. Locate the motor nameplate

NOTICE

The motor is either star (Y) or delta connected (Δ). This information is on the motor nameplate.

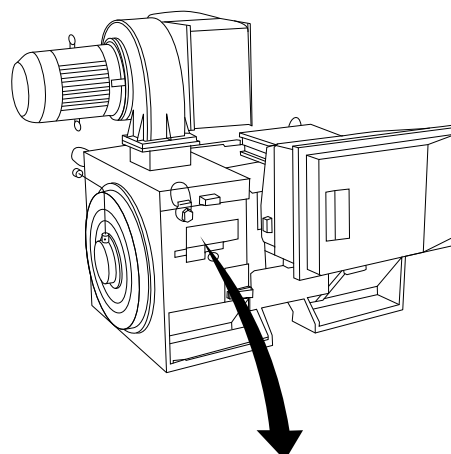

130BA767.10

THREE PHASE INDUCTION MOTOR					
MOD MCV 315E	Nr.	135189 12 04		IL/IN 6.5	
kW 400	PRIMARY				SF 1.15
HP 536	V 690	A 410.6	CONN Y	COS f 0.85	40
mm 1481	V	A	CONN	AMB 40	°C
Hz 50	V	A	CONN	ALT 1000	m
DESIGNN	SECONDARY			RISE 80	°C
DUTY S1	V	A	CONN	ENCLOSURE IP23	
INSUL I	EFFICIENCY %	95.8%	100%	95.8%	75%
					WEIGHT 1.83 ton
⚠ CAUTION					

Illustration 4.30 Nameplate

Step 2. Enter the motor nameplate data in this parameter list.

To access this list, press [Quick Menu] then select Q2 Quick Setup.

1. 1-20 Motor Power [kW]
1-21 Motor Power [HP]
2. 1-22 Motor Voltage
3. 1-23 Motor Frequency
4. 1-24 Motor Current
5. 1-25 Motor Nominal Speed

Step 3. Activate the Automatic Motor Adaptation (AMA)

Performing an AMA ensures optimum performance. The AMA measures the values from the motor model equivalent diagram.

1. Connect terminal 37 to terminal 12 (if terminal 37 is available).
2. Connect terminal 27 to terminal 12 or set 5-12 Terminal 27 Digital Input to [0] No function.
3. Activate the AMA 1-29 Automatic Motor Adaptation (AMA).
4. Select between complete or reduced AMA. If a sine-wave filter is mounted, run only the reduced AMA, or remove the sine-wave filter during the AMA procedure.

5. Press [OK]. The display shows *Press [Hand On] to start*.
6. Press [Hand On]. A progress bar indicates if the AMA is in progress.

Stop the AMA during operation

1. Press [Off] - the frequency converter enters into alarm mode and the display shows that the user terminated the AMA.

Successful AMA

1. The display shows *Press [OK] to finish AMA*.
2. Press [OK] to exit the AMA state.

Unsuccessful AMA

1. The frequency converter enters into alarm mode. A description of the alarm can be found in .
2. *Report Value* in the [Alarm Log] shows that the last measuring sequence carried out by the AMA, before the frequency converter entered alarm mode. This number along with the description of the alarm helps with troubleshooting. If contacting Danfoss for service, state the alarm number and description.

NOTICE

Incorrectly registered motor nameplate data or a too big difference between the motor power size and the frequency converter power size often causes unsuccessful AMA.

Step 4. Set the speed limit and ramp time

- 3-02 *Minimum Reference*
- 3-03 *Maximum Reference*

Step 5. Set up the desired limits for speed and ramp time.

- 4-11 *Motor Speed Low Limit [RPM]* or 4-12 *Motor Speed Low Limit [Hz]*
- 4-13 *Motor Speed High Limit [RPM]* or 4-14 *Motor Speed High Limit [Hz]*
- 3-41 *Ramp 1 Ramp Up Time*
- 3-42 *Ramp 1 Ramp Down Time*

4.5 Additional Connections

4.5.1 Mechanical Brake Control

In hoisting/lowering applications, it is necessary to be able to control an electro-mechanical brake:

- Control the brake using any relay output or digital output (terminal 27 or 29).
- Keep the output closed (voltage-free) as long as the frequency converter is unable to support the motor, for example due to the load being too heavy.

- Select [32] *Mechanical brake control* in parameter group 5-4* *Relays* for applications with an electro-mechanical brake.
- The brake is released when the motor current exceeds the preset value in 2-20 *Release Brake Current*.
- The brake is engaged when the output frequency is less than the frequency set in 2-21 *Activate Brake Speed [RPM]* or 2-22 *Activate Brake Speed [Hz]*, and only if the frequency converter carries out a stop command.

If the frequency converter is in alarm mode or in an over-voltage situation, the mechanical brake immediately cuts in.

4.5.2 Parallel Connection of Motors

The frequency converter can control several parallel-connected motors. The total current consumption of the motors must not exceed the rated output current $I_{M,N}$ for the frequency converter.

NOTICE

Installations with cables connected in a common joint as in *Illustration 4.31*, are only recommended for short cable lengths.

NOTICE

When motors are connected in parallel, *1-29 Automatic Motor Adaptation (AMA)* cannot be used.

NOTICE

The electronic thermal relay (ETR) of the frequency converter cannot be used as motor overload protection for the individual motor in systems with parallel-connected motors. Provide further motor overload protection, for example thermistors in each motor or individual thermal relays (circuit breakers are not suitable as protection).

4.5.3 Motor Thermal Protection

The electronic thermal relay in the frequency converter has received UL-approval for single motor overload protection, when *1-90 Motor Thermal Protection* is set for [4] *ETR Trip* and *1-24 Motor Current* are set to the rated motor current (see motor nameplate).

For thermal motor protection, it is also possible to use the MCB 112 PTC Thermistor Card option. This card provides ATEX certificate to protect motors in explosion hazardous areas, Zone 1/21 and Zone 2/22. When *1-90 Motor Thermal Protection* is set to [20] *ATEX ETR* and is combined with the use of MCB 112, it is possible to control an Ex-e motor in explosion hazardous areas. Consult the product relevant *Programming Guide* for details on how to set up the frequency converter for safe operation of Ex-e motors.

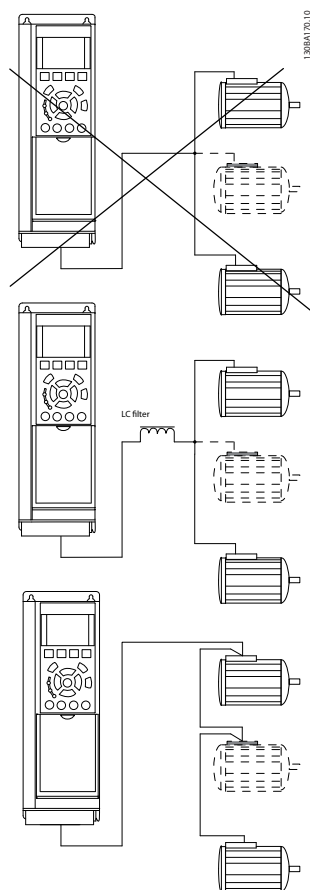

Illustration 4.31 Parallel Motor Connection

Problems may arise at start-up and at low RPM values if motor sizes are widely different because small motors' relatively high ohmic resistance in the stator calls for a higher voltage at start-up and at low RPM values.

5 How to operate the frequency converter

The frequency converter can be operated in 3 ways:

1. Graphical Local Control Panel (GLCP), see 6.1.2
2. Numeric Local Control Panel (NLCP), see 6.1.3
3. RS-485 serial communication or USB, both for PC connection, see 6.1.4

If the frequency converter is fitted with fieldbus option, refer to relevant documentation.

5.1.1 How to operate graphical LCP (GLCP)

The following instructions are valid for the GLCP (LCP 102).

The GLCP is divided into 4 functional groups:

1. Graphical display with Status lines.
2. Menu keys and indicator lights (LED's) - selecting mode, changing parameters and switching between display functions.
3. Navigation keys and indicator lights (LEDs).
4. Operation keys and indicator lights (LEDs).

Graphical display:

The LCD-display is back-lit with a total of 6 alpha-numeric lines. All data is displayed on the LCP which can show up to five operating variables while in [Status] mode.

Display lines:

- a. **Status line:** Status messages displaying icons and graphics.
- b. **Line 1-2:** Operator data lines displaying data and variables defined or chosen by the user. By pressing the [Status] key, up to one extra line can be added.
- c. **Status line:** Status messages displaying text.

The display is divided into 3 sections:

Top section (a)

shows the status when in status mode or up to 2 variables when not in status mode and in the case of Alarm/Warning.

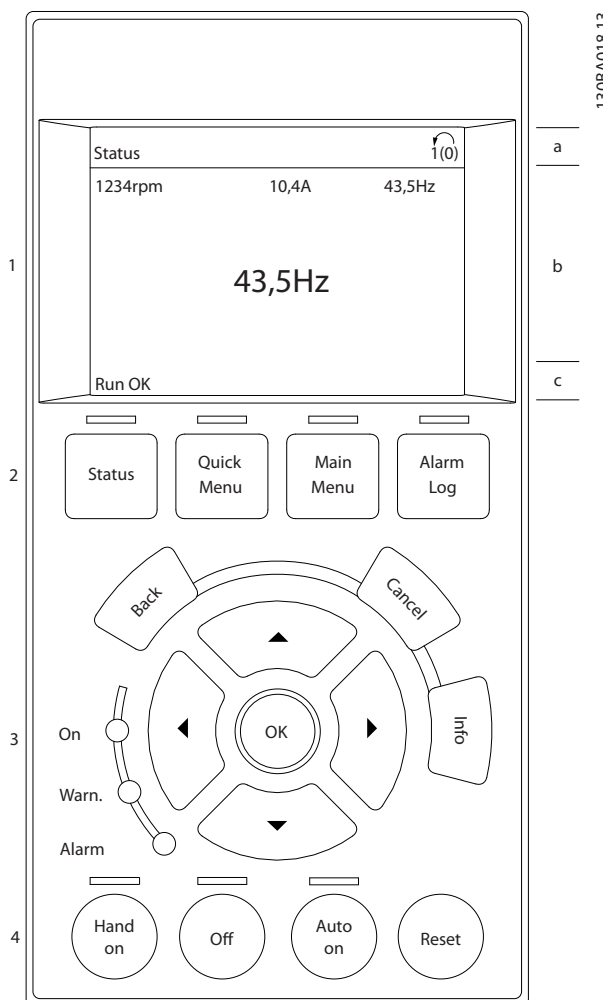

Illustration 5.1 LCP

The number of the Active Set-up (selected as the Active Set-up in 0-10 Active Set-up) is shown. When programming in another Set-up than the Active Set-up, the number of the Set-up being programmed appears to the right in brackets.

Middle section (b)

shows up to 5 variables with related unit, regardless of status. In case of alarm/warning, the warning is shown instead of the variables.

It is possible to toggle between three status read-out displays by pressing the [Status] key.

Operating variables with different formatting are shown in each status screen - see below.

Several values or measurements can be linked to each of the displayed operating variables. The values / measurements to be displayed can be defined via

0-20 Display Line 1.1 Small, 0-21 Display Line 1.2 Small, 0-22 Display Line 1.3 Small, 0-23 Display Line 2 Large, and 0-24 Display Line 3 Large, which can be accessed via [QUICK MENU], "Q3 Function Setups", "Q3-1 General Settings", "Q3-11 Display Settings".

Each value/measurement readout parameter selected in 0-20 Display Line 1.1 Small to 0-24 Display Line 3 Large has its own scale and number of digits after a possible decimal point. Larger numeric values are displayed with few digits after the decimal point.

Ex.: Current readout
5.25 A; 15.2 A 105 A.

Status display I

This read-out state is standard after start-up or initialization.

Use [INFO] to obtain information about the value/measurement linked to the displayed operating variables (1.1, 1.2, 1.3, 2, and 3).

See the operating variables shown in the display in this illustration. 1.1, 1.2 and 1.3 are shown in small size. 2 and 3 are shown in medium size.

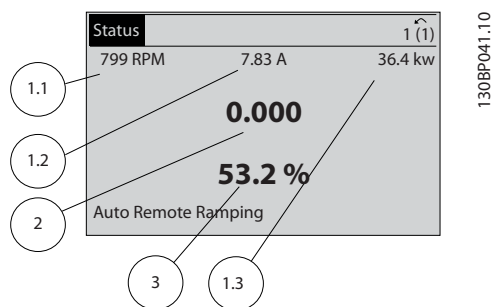

Illustration 5.2

Status display II

See the operating variables (1.1, 1.2, 1.3, and 2) shown in the display in Illustration 5.3.

In the example, Speed, Motor current, Motor power and Frequency are selected as variables in the first and second lines.

1.1, 1.2 and 1.3 are shown in small size. 2 is shown in large size.

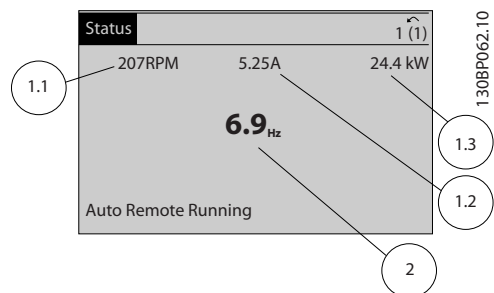

Illustration 5.3

Status display III:

This state displays the event and action of the Smart Logic Control. For further information, see .

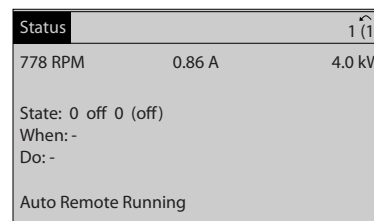

Illustration 5.4

Bottom section

always shows the state of the frequency converter in Status mode.

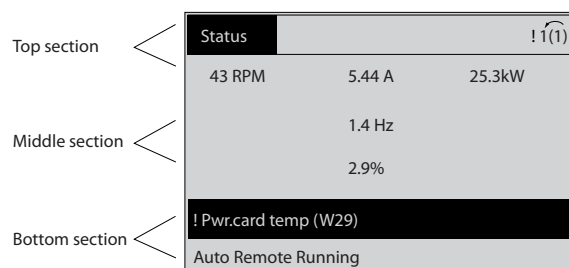

Illustration 5.5

Display contrast adjustment

Press [status] and [▲] for darker display
Press [status] and [▼] for brighter display

Indicator lights (LEDs)

If certain threshold values are exceeded, the alarm and/or warning LED lights up. A status and alarm text appear on the control panel.

The On LED is activated when the frequency converter receives power from mains voltage, a DC bus terminal, or an external 24 V supply. At the same time, the back light is on.

- Green LED/On: Control section is working.
- Yellow LED/Warn.: Indicates a warning.
- Flashing Red LED/Alarm: Indicates an alarm.

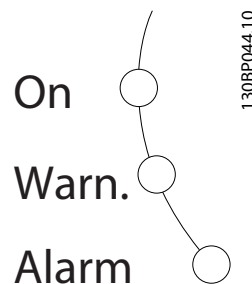

Illustration 5.6

GLCP keys

Menu keys

The menu keys are divided into functions. The keys below the display and indicator lamps are used for parameter set-up, including choice of display indication during normal operation.



Illustration 5.7

[Status]

Indicates the status of the frequency converter and/or the motor. 3 different readouts can be chosen by pressing the [Status] key:

5 line readouts, 4 line readouts or Smart Logic Control.

Use [Status] for selecting the mode of display or for changing back to Display mode from either the Quick Menu mode, the Main Menu mode or Alarm mode. Also use the [Status] key to toggle single or double read-out mode.

[Quick Menu]

Allows quick set-up of the frequency converter. **The most common functions can be programmed here.**

The [Quick Menu] consists of:

- Q1: My Personal Menu
- Q2: Quick Setup
- Q3: Function Setups
- Q5: Changes Made
- Q6: Loggings

The Function set-up provides quick and easy access to all parameters required for the majority of water and wastewater applications including variable torque, constant torque, pumps, dosing pumps, well pumps, booster pumps, mixer pumps, aeration blowers and other pump and fan applications. Amongst other features it also includes parameters for selecting which variables to display on the LCP, digital preset speeds, scaling of analog references, closed loop single zone and multi-zone applications and specific functions related to water and wastewater applications.

The Quick Menu parameters can be accessed immediately unless a password has been created via *0-60 Main Menu Password, 0-61 Access to Main Menu w/o Password, 0-65 Personal Menu Password or 0-66 Access to Personal Menu w/o Password.*

It is possible to switch directly between Quick Menu mode and Main Menu mode.

[Main Menu]

is used for programming all parameters.

The Main Menu parameters can be accessed immediately unless a password has been created via *0-60 Main Menu Password, 0-61 Access to Main Menu w/o Password, 0-65 Personal Menu Password or 0-66 Access to Personal Menu w/o Password.* For the majority of water and wastewater applications it is not necessary to access the Main Menu parameters but instead the Quick Menu, Quick Setup and Function Setups provides the simplest and quickest access to the typical required parameters. It is possible to switch directly between Main Menu mode and Quick Menu mode.

Parameter shortcut can be carried out by pressing down the [Main Menu] key for 3 seconds. The parameter shortcut allows direct access to any parameter.

[Alarm Log]

displays an Alarm list of the five latest alarms (numbered A1-A5). To obtain additional details about an alarm, use the arrow keys to manoeuvre to the alarm number and press [OK]. Information is displayed about the condition of the frequency converter before it enters the alarm mode.

[Back]

reverts to the previous step or layer in the navigation structure.

[Cancel]

last change or command will be cancelled as long as the display has not been changed.

[Info]

displays information about a command, parameter, or function in any display window. [Info] provides detailed information when needed.

Exit Info mode by pressing either [Info], [Back], or [Cancel].

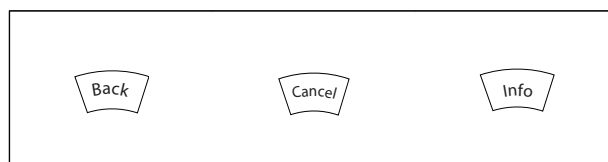

Table 5.1

Navigation keys

The four navigation arrows are used to navigate between the different choices available in [Quick Menu], [Main Menu] and [Alarm Log]. Use the keys to move the cursor.

[OK]

is used for choosing a parameter marked by the cursor and for enabling the change of a parameter.

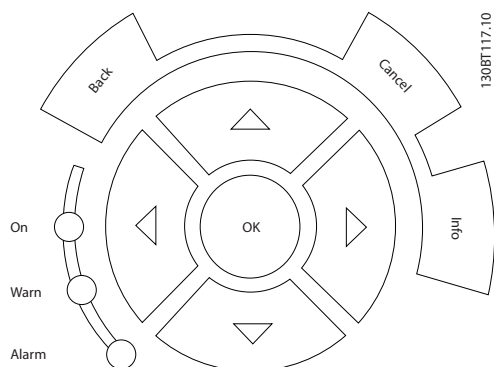

Illustration 5.8

5

Operation keys

for local control are found at the bottom of the control panel.

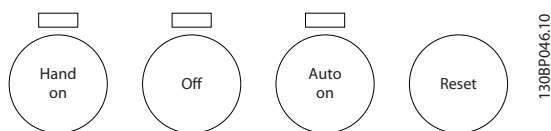

Illustration 5.9

[Hand on]

enables control of the frequency converter via the GLCP. [Hand on] also starts the motor, and it is now possible to give the motor speed reference by means of the arrow keys. The key can be *Enabled* [1] or *Disabled* [0] via 0-40 [Hand on] Key on LCP

The following control signals will still be active when

[Hand on] is activated:

- [Hand on] - [Off] - [Auto on]
- Reset
- Coasting stop inverse (motor coasting to stop)
- Reversing
- Set-up select lsb - Set-up select msb
- Stop command from serial communication
- Quick stop
- DC brake

NOTICE

External stop signals activated by means of control signals or a serial bus will override a "start" command via the LCP.

[Off]

stops the connected motor. The key can be *Enabled* [1] or *Disabled* [0] via 0-41 [Off] Key on LCP If no external stop function is selected and the [Off] key is inactive the motor can only be stopped by disconnecting the mains supply.

[Auto on]

enables the frequency converter to be controlled via the control terminals and/or serial communication. When a start signal is applied on the control terminals and/or the bus, the frequency converter will start. The key can be *Enabled* [1] or *Disabled* [0] via 0-42 [Auto on] Key on LCP

NOTICE

An active HAND-OFF-AUTO signal via the digital inputs has higher priority than the control keys [Hand on] – [Auto on].

[Reset]

is used for resetting the frequency converter after an alarm (trip). The key can be *Enabled* [1] or *Disabled* [0] via 0-43 [Reset] Key on LCP.

The parameter shortcut

can be carried out by holding down the [Main Menu] key for 3 seconds. The parameter shortcut allows direct access to any parameter.

5.1.2 How to Operate Numeric LCP (NLCP)

The following instructions are valid for the NLCP (LCP 101).

The control panel is divided into 4 functional groups, see *Illustration 5.10*:

1. Numeric display
2. Menu key and indicator lights (LEDs) - changing parameters and switching between display functions
3. Navigation keys and indicator lights (LEDs)
4. Operation keys and indicator lights (LEDs)

NOTICE

Parameter copy is not possible with Numeric Local Control Panel (LCP101).

Select one of the following modes:

Status Mode: Displays the status of the frequency converter or the motor.

If an alarm occurs, the NLCP automatically switches to status mode.

A number of alarms can be displayed.

Quick Setup or Main Menu Mode: Display parameters and parameter settings.

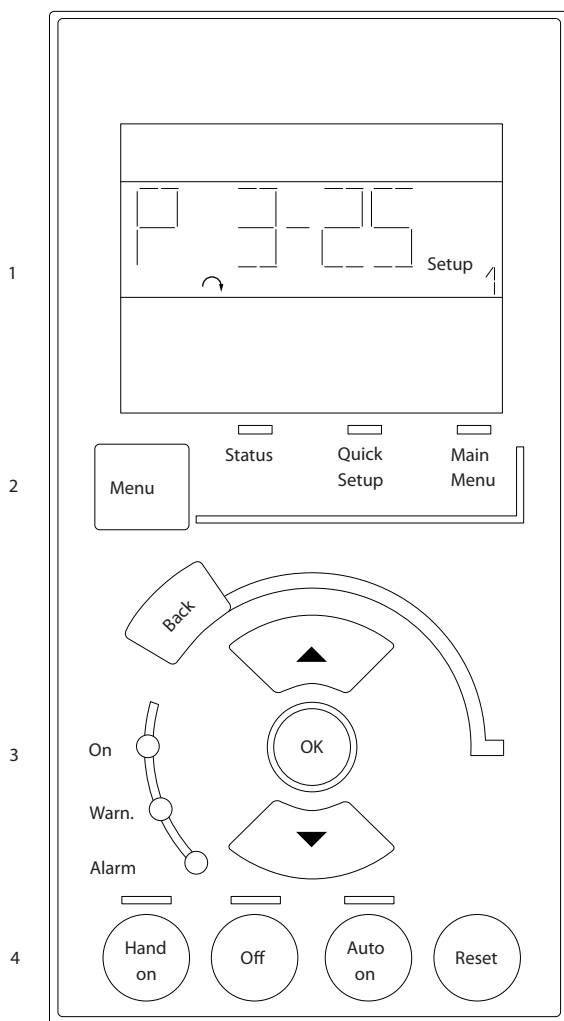

130BA191.10

Illustration 5.10 Numerical LCP (NLCP)

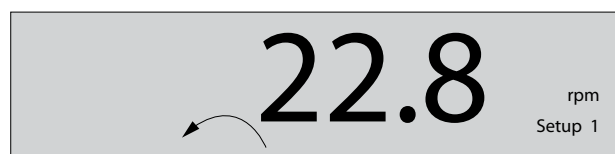

130BP077.10

Illustration 5.11 Status display example



130BP078.10

Illustration 5.12 Alarm display example

Indicator lights (LEDs):

- Green LED/On: Indicates if control section is on.
- Yellow LED/Wrn.: Indicates a warning.
- Flashing red LED/Alarm: Indicates an alarm.

Menu key

Select one of the following modes:

- Status
- Quick Setup
- Main Menu

Main Menu

is used for programming all parameters.

The parameters can be accessed immediately unless a password has been created via 0-60 Main Menu Password, 0-61 Access to Main Menu w/o Password, 0-65 Personal Menu Password or 0-66 Access to Personal Menu w/o Password.

Quick Setup is used to set up the frequency converter using only the most essential parameters.

The parameter values can be changed using the up/down arrows when the value is flashing.

Select Main Menu by pressing the [Menu] key a number of times until the Main Menu LED is lit.

Select the parameter group [xx-__] and press [OK]

Select the parameter [__-xx] and press [OK]

If the parameter is an array parameter select the array number and press [OK]

Select the wanted data value and press [OK]

Navigation keys

[Back]

for stepping backwards

[▲] [▼]

keys are used for manoeuvring between parameter groups, parameters and within parameters

[OK]

is used for choosing a parameter marked by the cursor and for enabling the change of a parameter.

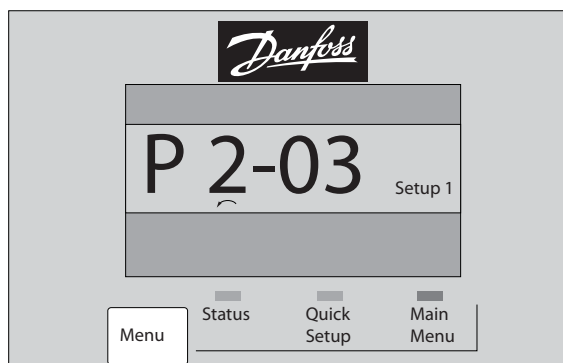

130BP079.10

Illustration 5.13 Display example

Operation keys

Keys for local control are found at the bottom of the control panel.

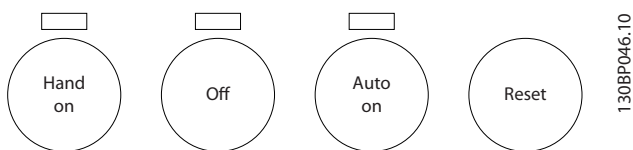

Illustration 5.14 Operation keys of the numerical LCP (NLCP)

[Hand on]

enables control of the frequency converter via the LCP. [Hand on] also starts the motor and it is now possible to enter the motor speed data by means of the navigation keys. The key can be [1] Enabled or [0] Disabled via 0-40 [Hand on] Key on LCP.

External stop signals activated by means of control signals or a serial bus will override a 'start' command via the LCP.

The following control signals are still active when [Hand on] is activated:

- [Hand on] - [Off] - [Auto on]
- Reset
- Coasting stop inverse
- Reversing
- Set-up select lsb - Set-up select msb
- Stop command from serial communication
- Quick stop
- DC brake

[Off]

stops the connected motor. The key can be [1] Enabled or [0] Disabled via 0-41 [Off] Key on LCP.

If no external stop function is selected and the [Off] key is inactive the motor can be stopped by disconnecting the mains supply.

[Auto on]

enables the frequency converter to be controlled via the control terminals and/or serial communication. When a start signal is applied on the control terminals and/or the bus, the frequency converter starts. The key can be [1] Enabled or [0] Disabled via 0-42 [Auto on] Key on LCP.

NOTICE

An active HAND-OFF-AUTO signal via the digital inputs has higher priority than the control keys [Hand on] [Auto on].

[Reset]

is used for resetting the frequency converter after an alarm (trip). The key can be [1] Enabled or [0] Disabled via 0-43 [Reset] Key on LCP.

5.1.3 Changing Data

1. Press [Quick Menu] or [Main Menu] key.
2. Press [▲] and [▼] to find parameter group to edit.
3. Press [OK] key.
4. Press [▲] and [▼] to find parameter to edit.
5. Press [OK] key.
6. Press [▲] and [▼] to select correct parameter setting. Or, to move to digits within a number, press keys. Cursor indicates digit selected to change. [▲] increases the value, [▼] decreases the value.
7. Press [Cancel] to disregard change, or press [OK] to accept change and enter new setting.

5.1.4 Changing a Text Value

If the selected parameter is a text value, change the text value with the [▲]/[▼] keys.

[▲] increases the value, and [▼] decreases the value. Place the cursor on the value to be saved and press [OK].

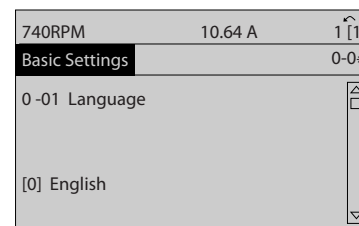

Illustration 5.15 Display Example

5.1.5 Changing a Group of Numeric Data Values

If the selected parameter represents a numeric data value, change the selected data value with the [◀] and [▶] keys as well as the up/down [▲] [▼] keys. Press [◀] and [▶] to move the cursor horizontally.

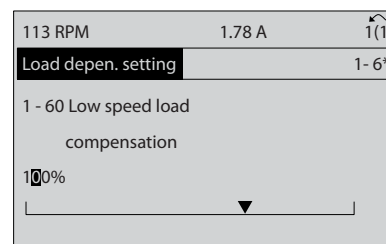

Illustration 5.16 Display Example

Press [▲] and [▼] to change the data value. [▲] increases the data value, and [▼] decreases the data value. Place the cursor on the value to be saved and press [OK].

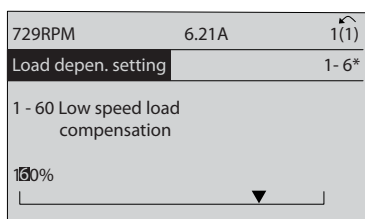

Illustration 5.17 Display Example

5.1.6 Changing of Data Value, Step-by-Step

Certain parameters can be changed step by step or infinitely variably. This applies to *parameter 1-20 Motor Power [kW]*, *parameter 1-22 Motor Voltage* and *parameter 1-23 Motor Frequency*.

The parameters are changed both as a group of numeric data values and as numeric data values infinitely variably.

5.1.7 Readout and Programming of Indexed Parameters

Parameters are indexed when placed in a rolling stack. *15-30 Alarm Log: Error Code* to *15-32 Alarm Log: Time* contain a fault log which can be read out. Select a parameter, press [OK], and use [▲] and [▼] to scroll through the value log.

Use *parameter 3-10 Preset Reference* as another example: Select the parameter, press [OK], and use [▲] and [▼] to scroll through the indexed values. To change the parameter value, select the indexed value and press [OK]. Change the value by [▲] and [▼]. Press [OK] to accept the new setting. Press [Cancel] to abort. Press [Back] to leave the parameter.

5.1.8 Tips and Tricks

- For the majority of water and wastewater applications the Quick Menu, Quick Set-up and Function Set-up provides the simplest and quickest access to all the typical parameters required.
- Whenever possible, performing an AMA, ensures best shaft performance.
- Contrast of the display can be adjusted by pressing [Status] and [▲] for darker display or by pressing [Status] and [▼] for brighter display.

- Under [Quick Menu] and [Changes Made] all parameters that have been changed from factory settings are displayed.
- Press and hold [Main Menu] key for 3 s for access to any parameter.
- For service purposes it is recommended to copy all parameters to the LCP, see *0-50 LCP Copy* for further information.

5.1.9 Quick Transfer of Parameter Settings when Using GLCP

Once the set-up of a frequency converter is complete, store (back up) the parameter settings in the GLCP or on a PC via MCT 10 Set-up Software.

WARNING

Stop the motor before performing any of these operations.

Data storage in LCP

1. Go to *0-50 LCP Copy*.
2. Press [OK].
3. Select [1] All to LCP.
4. Press [OK].

All parameter settings are now stored in the GLCP indicated by the progress bar. When 100% is reached, press [OK].

The GLCP can now be connected to another frequency converter and the parameter settings copied to this frequency converter.

Data transfer from LCP to frequency converter

1. Go to *0-50 LCP Copy*.
2. Press [OK].
3. Select [2] All from LCP.
4. Press [OK]

The parameter settings stored in the GLCP are now transferred to the frequency converter indicated by the progress bar. When 100% is reached, press [OK].

5.1.10 Initialisation to Default Settings

There are 2 ways to initialise the frequency converter to default: Recommended initialisation and manual initialisation.

Be aware that they have different impact according to the following description.

Recommended initialisation (via 14-22 Operation Mode)

1. Select *14-22 Operation Mode*.
2. Press [OK].
3. Select *[2] Initialisation* (for NLCP select "2").
4. Press [OK].
5. Remove power to unit and wait for display to turn off.
6. Reconnect power and the frequency converter is reset. Note that first start-up takes a few more seconds.
7. Press [Reset]

14-22 Operation Mode initialises all except:

14-50 RFI Filter

8-30 Protocol

8-31 Address

8-32 Baud Rate

8-35 Minimum Response Delay

8-36 Max Response Delay

8-37 Maximum Inter-Char Delay

15-00 Operating hours to 15-05 Over Volt's

15-20 Historic Log: Event to 15-22 Historic Log: Time

15-30 Alarm Log: Error Code to 15-32 Alarm Log: Time

NOTICE

Parameters selected in *0-25 My Personal Menu* stay present with default factory setting.

Manual initialisation**NOTICE**

When carrying out manual initialisation, serial communication, RFI filter settings and fault log settings are reset. Removes parameters selected in *0-25 My Personal Menu*.

1. Disconnect from mains and wait until the display turns off.
2. Press
 - 2a [Status] - [Main Menu] - [OK] at the same time while powering up for Graphical LCP (GLCP).
 - 2b [Menu] while powering up for LCP 101, Numerical Display.
3. Release the keys after 5 s.
4. The frequency converter is now programmed according to default settings.

This parameter initialises all except:

15-00 Operating hours

15-03 Power Up's

15-04 Over Temp's

15-05 Over Volt's

5.1.11 RS-485 Bus Connection

One or more frequency converters can be connected to a controller (or master) using the RS-485 standard interface. Terminal 68 is connected to the P signal (TX+, RX+), while terminal 69 is connected to the N signal (TX-, RX-).

If more than one frequency converter is connected to a master, use parallel connections.

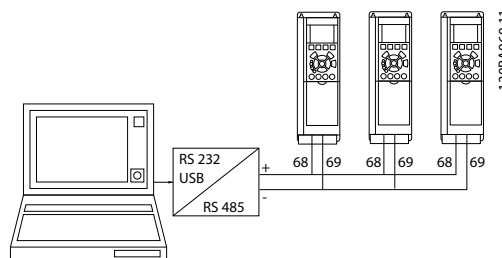

Illustration 5.18 Connection Example.

To avoid potential equalising currents in the screen, ground the cable screen via terminal 61, which is connected to the frame via an RC-link.

Bus termination

Terminate the RS-485 bus by a resistor network at both ends. If the frequency converter is the first or the last device in the RS-485 loop, set the switch S801 on the control card for ON.

For more information, see the paragraph *Switches S201, S202, and S801*.

5.1.12 How to Connect a PC to the Frequency Converter

To control or program the frequency converter from a PC, install the PC-based configuration tool MCT 10 Set-up Software.

The PC is connected via a standard (host/device) USB cable, or via the RS-485 interface as shown in *chapter 5.1.11 RS-485 Bus Connection*.

NOTICE

The USB connection is galvanically isolated from the supply voltage (PELV) and other high-voltage terminals. The USB connection is connected to protective earth. Use only an isolated laptop as PC connection to the USB connector on the frequency converter.

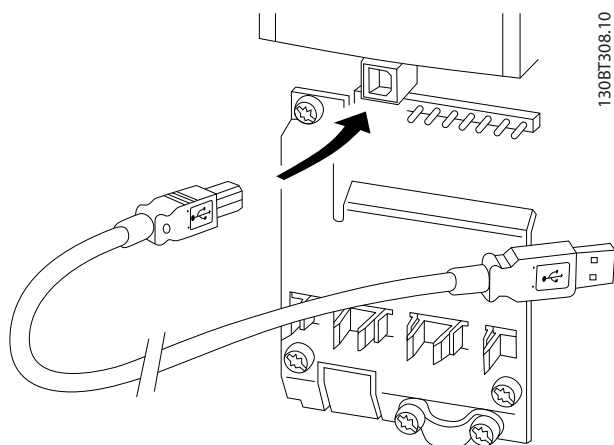

Illustration 5.19 USB Connection to Frequency Converter

5.1.13 PC Software Tools

PC-based MCT 10 Set-up Software

All frequency converters are equipped with a serial communication port. Danfoss provides a PC tool for communication between PC and frequency converter. Check the section on for detailed information on this tool.

MCT 10 Set-up Software

MCT 10 Set-up Software has been designed as an easy to use interactive tool for setting parameters in our frequency converters.

The MCT 10 Set-up Software is useful for:

- Planning a communication network off-line. MCT 10 Set-up Software contains a complete frequency converter database.
- Commissioning frequency converters on line.
- Saving settings for all frequency converters.
- Replacing a frequency converter in a network.
- Simple and accurate documentation of frequency converter settings after commissioning.
- Expanding an existing network.
- Future developed frequency converters are supported.

MCT 10 Set-up Software supports Profibus DP-V1 via a master class 2 connection. It enables online reading/writing of parameters in a frequency converter via the Profibus network. This network eliminates the need for an extra communication network.

Save frequency converter settings:

1. Connect a PC to the unit via USB com port. (NOTE: Use a PC, which is isolated from the

mains, with the USB port. Failure to do so may damage equipment.).

2. Open MCT 10 Set-up Software.
3. Select *Read from drive*.
4. Select *Save as*.

All parameters are now stored in the PC.

Load frequency converter settings:

1. Connect a PC to the frequency converter via USB com port.
2. Open MCT 10 Set-up Software.
3. Select *Open* – stored files are shown.
4. Open the appropriate file.
5. Select *Write to drive*.

All parameter settings are now transferred to the frequency converter.

A separate manual for MCT 10 Set-up Software is available from www.Danfoss.com/BusinessAreas/DrivesSolutions/Softwaredownload/DDPC+Software+Program.htm.

The MCT 10 Set-up software modules

The following modules are included in the software package.

	<p>MCT Set-up 10 Software Setting parameters Copy to and from frequency converters Documentation and print of parameter settings incl. diagrams</p>
	<p>Ext. user interface Preventive Maintenance Schedule Clock settings Timed Action Programming Smart Logic Controller Set-up</p>

Table 5.2

Ordering number:

Order the CD containing MCT 10 Set-up Software using code number 130B1000.

The software can be downloaded from the Danfoss internet site www.Danfoss.com/BusinessAreas/DrivesSolutions/Softwaredownload/DDPC+Software+Program.htm

6 How to programme the frequency converter

6.1 How to programme

The parameters are grouped into various parameter groups for easy selection of the correct parameter for optimised frequency converter operation.

Overview of parameter groups

Group	Title	Function
0-**	Operation/Display	Parameters related to the fundamental functions of the frequency converter, function of the LCP keys and configuration of the LCP display.
1-**	Load/Motor	Parameter group for motor settings.
2-**	Brakes	Parameter group for setting brake features in the frequency converter.
3-**	Reference/Ramps	Parameters for reference handling, definitions of limitations, and configuration of the reaction of the frequency converter to changes.
4-**	Limits/Warnings	Parameter group for configuring limits and warnings.
5-**	Digital In/Out	Parameter group for configuring the digital inputs and outputs.
6-**	Analog In/Out	Parameter group for configuration of the analog inputs and outputs.
8-**	Communication and Options	Parameter group for configuring communications and options.
9-**	Profibus	Parameter group for Profibus-specific parameters (requires profibus option).
10-**	DeviceNet Fieldbus	Parameter group for DeviceNet-specific parameters (requires DeviceNet option).
13-**	Smart Logic	Parameter group for Smart Logic Control
14-**	Special Functions	Parameter group for configuring special frequency converter functions.
15-**	Drive Information	Parameter group containing frequency converter information such as operating data, hardware configuration and software versions.
16-**	Data Readouts	Parameter group for data read-outs, e.g. actual references, voltages, control, alarm, warning and status words.
18-**	Info and Readouts	This parameter group contains the last 10 preventive maintenance logs.
20-**	Drive Closed Loop	This parameter group is used for configuring the closed loop PID controller that controls the output frequency of the unit.
21-**	Extended Closed Loop	Parameters for configuring the 3 extended closed loop PID controllers.
22-**	Application Functions	These parameters monitor water applications.
23-**	Time-based Functions	These parameters are for actions needed to be performed on a daily or weekly basis, e.g. different references for working hours/non-working hours.
24-**	Application Functions 2	Parameters for the drive bypass.
25-**	Basic Cascade Controller Functions	Parameters for configuring the basic cascade controller for sequence control of multiple pumps.
26-**	Analog I/O Option MCB 109	Parameters for configuring the analog I/O option MCB 109.
27-**	Extended Cascade Control	Parameters for configuring the extended cascade control (MCO 101/MCO 102).
29-**	Water Application Functions	Parameters for setting water specific functions.
30-**	Special Features	Parameters for configuring the brake resistor value.
31-**	Bypass Option	Parameters for configuring the bypass option (MCO 104).
35-**	Sensor Input Option	Parameters for configuring the sensor input option (MCB 114)

Table 6.1 Parameter Groups

Parameter descriptions and selections are displayed in the graphic LCP (GLCP) or numeric LCP (NLCP) in the display area. (See for details.) Access the parameters by pressing [Quick Menu] or [Main Menu] on the LCP. The Quick Menu is used primarily for commissioning the unit at start-up by providing those parameters necessary to start operation. The Main Menu provides access to all parameters for detailed application programming.

All digital input/output and analog input/output terminals are multifunctional. All terminals have factory default functions suitable for the majority of water applications, but if other special functions are required, they must be programmed in parameter groups 5-** *Digital In/out* or 6-** *Analog In/out*.

6.1.1 Quick Menu Mode

The GLCP provides access to all parameters listed under the Quick Menus. To set parameters using the [Quick Menu] key:

Pressing [Quick Menu] the list indicates the different areas contained in the Quick menu.

Efficient parameter set-up for water applications

The parameters can easily be set up for the vast majority of the water and wastewater applications only by using the [Quick Menu].

The optimum way to set parameters through the [Quick Menu] is by following the below steps:

1. Press [Quick Setup] for selecting basic motor settings, ramp times, etc.
2. Press [Function Setups] for setting up the required functionality of the frequency converter - if not already covered by the settings in [Quick Setup].
3. Select between *General Settings*, *Open Loop Settings* and *Closed Loop Settings*.

It is recommended to do the set-up in the order listed.

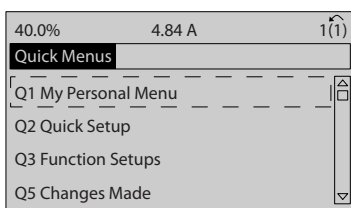

130BP064.10

Illustration 6.1 Quick Menu View

Par.	Designation	[Units]
0-01	Language	
1-20	Motor Power	[kW]
1-22	Motor Voltage	[V]
1-23	Motor Frequency	[Hz]
1-24	Motor Current	[A]
1-25	Motor Nominal Speed	[RPM]
3-41	Ramp 1 Ramp up Time	[s]
3-42	Ramp 1 Ramp down Time	[s]
4-11	Motor Speed Low Limit	[RPM]
4-13	Motor Speed High Limit	[RPM]
1-29	Automatic Motor Adaptation (AMA)	

Table 6.2 Quick Setup parameters.

See

If *No Operation* is selected in terminal 27 no connection to +24 V on terminal 27 is necessary to enable start. If *Coast Inverse* (factory default value) is selected in Terminal 27, a connection to +24 V is necessary to enable start.

NOTICE

For detailed parameter descriptions, see .

6.1.2 Q1 My Personal Menu

Parameters defined by the user can be stored in Q1 My Personal Menu.

Select *My Personal Menu* to display only the parameters, which have been pre-selected and programmed as personal parameters. For example, a pump or equipment OEM may have pre-programmed these to be in My Personal Menu during factory commissioning to make on site commissioning/fine tuning simpler. These parameters are selected in par. 0-25 *My Personal Menu*. Up to 20 different parameters can be defined in this menu.

Parameter 20-21 Setpoint 1
Parameter 20-93 PID Proportional Gain
Parameter 20-94 PID Integral Time

Table 6.3 Q1 My Personal Menu

6.1.3 Q2 Quick Setup

The parameters in Q2 Quick Setup are the basic parameters which are always needed to set-up the frequency converter to operation.

Parameter number and name	Unit
0-01 Language	
Parameter 1-20 Motor Power [kW]	kW
Parameter 1-22 Motor Voltage	V
Parameter 1-23 Motor Frequency	Hz
Parameter 1-24 Motor Current	A
Parameter 1-25 Motor Nominal Speed	RPM
Parameter 3-41 Ramp 1 Ramp Up Time	s
Parameter 3-42 Ramp 1 Ramp Down Time	s
Parameter 4-11 Motor Speed Low Limit [RPM]	RPM
Parameter 4-13 Motor Speed High Limit [RPM]	RPM
Parameter 1-29 Automatic Motor Adaptation (AMA)	

Table 6.4 Q2 Quick Setup

6

6.1.4 Q3 Function Set-ups

The Function Set-up provides quick and easy access to all parameters required for the majority of water and wastewater applications including variable torque, constant torque, pumps, dosing pumps, well pumps, booster pumps, mixer pumps, aeration blowers and other pump and fan applications. Amongst other features, it also includes parameters for selecting which variables to display on the LCP, digital preset speeds, scaling of analog references, closed loop single zone and multi-zone applications and specific functions related to water and wastewater applications.

How to access Function Set-up - example:

1. Turn on the frequency converter (On LED lights)

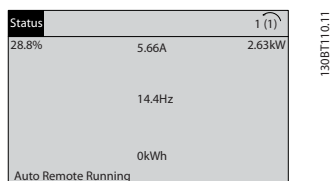

Illustration 6.2

2. Press the [Quick Menus] key (Quick Menu choices appear).

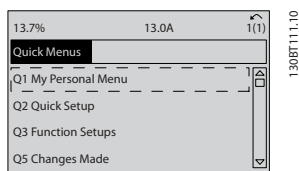

Illustration 6.3

3. Press [▲]/[▼] navigation keys to scroll down to Function Set-ups. Press [OK].

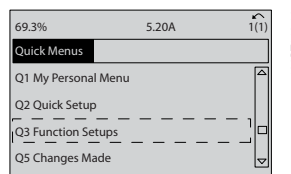

Illustration 6.4

4. Function Set-ups choices appear. Select Q3-1 General Settings. Press [OK].

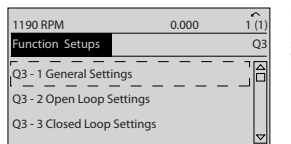

Illustration 6.5

5. Press [▲]/[▼] keys to scroll down to i.e. Q3-12 Analog Outputs. Press [OK].

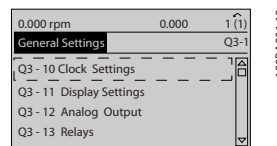

Illustration 6.6

6. Select parameter 6-50 Terminal 42 Output. Press [OK].

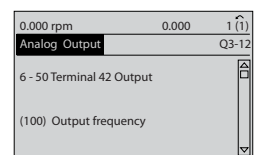

Illustration 6.7

7. Press [▲]/[▼] keys to select between the different choices. Press [OK].

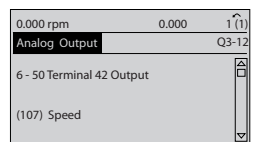

Illustration 6.8

The Function Setup parameters are grouped in the following way:

Q3-10 Clock Settings	Q3-11 Display Settings	Q3-12 Analog Output	Q3-13 Relays
0-70 Date and Time	0-20 Display Line 1.1 Small	Parameter 6-50 Terminal 42 Output	Relay 1 ⇒ 5-40 Function Relay
0-71 Date Format	0-21 Display Line 1.2 Small	Parameter 6-51 Terminal 42 Output Min Scale	Relay 2 ⇒ 5-40 Function Relay
Parameter 0-72 Time Format	0-22 Display Line 1.3 Small	Parameter 6-52 Terminal 42 Output Max Scale	Option relay 7 ⇒ 5-40 Function Relay
Parameter 0-74 DST/Summertime	0-23 Display Line 2 Large		Option relay 8 ⇒ 5-40 Function Relay
Parameter 0-76 DST/Summertime Start	0-24 Display Line 3 Large		Option relay 9 ⇒ 5-40 Function Relay
Parameter 0-77 DST/Summertime End	Parameter 0-37 Display Text 1		
	parameter 0-38 Display Text 2		
	parameter 0-39 Display Text 3		

Table 6.5 Q3-1 General Settings

Q3-20 Digital Reference	Q3-21 Analog Reference
Parameter 3-02 Minimum Reference	Parameter 3-02 Minimum Reference
3-03 Maximum Reference	3-03 Maximum Reference
Parameter 3-10 Preset Reference	Parameter 3-10 Preset Reference
5-13 Terminal 29 Digital Input	Parameter 6-11 Terminal 53 High Voltage
5-14 Terminal 32 Digital Input	Parameter 6-14 Terminal 53 Low Ref./Feedb. Value
5-15 Terminal 33 Digital Input	Parameter 6-15 Terminal 53 High Ref./Feedb. Value

Q3-30 Feedback Settings	Q3-31 PID Settings
Parameter 1-00 Configuration Mode	Parameter 20-81 PID Normal/ Inverse Control
20-12 Reference/Feedback Unit	Parameter 20-82 PID Start Speed [RPM]
Parameter 3-02 Minimum Reference	Parameter 20-21 Setpoint 1
3-03 Maximum Reference	Parameter 20-93 PID Proportional Gain
Parameter 6-20 Terminal 54 Low Voltage	Parameter 20-94 PID Integral Time
Parameter 6-21 Terminal 54 High Voltage	
Parameter 6-24 Terminal 54 Low Ref./Feedb. Value	
Parameter 6-25 Terminal 54 High Ref./Feedb. Value	
Parameter 6-00 Live Zero Timeout Time	
Parameter 6-01 Live Zero Timeout Function	

6.1.5 Q5 Changes Made

Q5 Changes Made can be used for fault finding.

Select Changes made to get information about:

- the last 10 changes. Use the up/down navigation keys to scroll between the last 10 changed parameters.
- the changes made since default setting.

Select *Loggings* to get information about the display line read-outs. The information is shown as graphs.

Only display parameters selected in *parameter 0-20 Display Line 1.1 Small* and *0-24 Display Line 3 Large* can be viewed. It is possible to store up to 120 samples in the memory for later reference.

Note that the parameters listed in *Table 6.6* to *Table 6.6* for Q5 only serve as examples as they vary depending on the programming of the particular frequency converter.

Parameter 20-94 PID Integral Time
Parameter 20-93 PID Proportional Gain

Parameter 20-93 PID Proportional Gain
Parameter 20-94 PID Integral Time

Analog Input 53
Analog Input 54

6.1.6 Q6 Loggings

Q6 Loggings can be used for fault finding.

Notice that the parameters listed in *Table 6.6* for Q6 only serve as examples as they vary depending on the programming of the particular frequency converter.

Reference
Analog Input 53
Motor Current
Frequency
Feedback
Energy Log
Trending Cont Bin
Trending Timed Bin
Trending Comparison

6.1.7 Main Menu Mode

Both the GLCP and NLCP provide access to the main menu mode. Select the Main Menu mode by pressing [Main Menu]. *Illustration 6.9* shows the resulting readout, which appears on the display of the GLCP.

Lines 2 to 5 on the display show a list of parameter groups which can be selected by toggling [▲] and [▼].

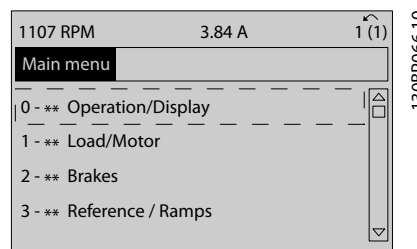

Illustration 6.9 Display Example

Each parameter has a name and number which remain the same regardless of the programming mode. In the Main Menu mode, the parameters are divided into groups. The first digit of the parameter number (from the left) indicates the parameter group number.

All parameters can be changed in the Main Menu. The configuration of the unit (*parameter 1-00 Configuration Mode*) determines other parameters available for programming. For example, selecting closed loop enables more parameters related to closed loop operation. Option cards added to the unit enable more parameters associated with the option device.

6.1.8 Parameter Selection

In the Main Menu mode, the parameters are divided into groups. Press the navigation keys to select a parameter group.

The following parameter groups are accessible:

Group no.	Parameter group
0-**	Operation/Display
1-**	Load/Motor
2-**	Brakes
3-**	References/Ramps
4-**	Limits/Warnings
5-**	Digital In/Out
6-**	Analog In/Out
8-**	Comm. and Options
9-**	Profibus
10-**	CAN Fieldbus
11-**	LonWorks
13-**	Smart Logic
14-**	Special Functions
15-**	FC Information
16-**	Data Readouts
18-**	Data Readouts 2
20-**	FC Closed Loop
21-**	Ext. Closed Loop
22-**	Application Functions

Group no.	Parameter group
23-**	Time Actions
25-**	Cascade Controller
26-**	Analog I/O Option MCB 109
27-**	Cascade CTL Option
29-**	Water Application Functions
31-**	Bypass Option

Table 6.6 Parameter Groups

After selecting a parameter group, select a parameter with the navigation keys.

The middle section on the GLCP display shows the parameter number and name as well as the selected parameter value.

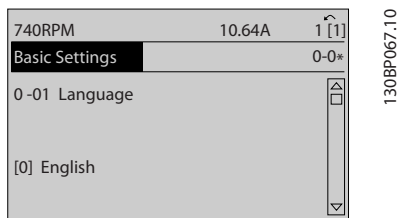

Illustration 6.10 Display Example

6.2 Commonly Used Parameters - Explanations

6.2.1 Main Menu

The Main Menu includes all available parameters in the frequency converter.

All parameters are grouped in a logic way with a group name indicating the function of the parameter group. All parameters are listed by name and number in .

All parameters included in the Quick Menu (Q1, Q2, Q3, Q5 and Q6) can be found in the following.

Some of the most used parameters for VLT® AQUA Drive applications are also explained in the following section.

For a detailed explanation of all parameters, refer to the *VLT® AQUA Drive Programming Guide* which is available at www.danfoss.com/BusinessAreas/DrivesSolutions/Documentations/Technical+Documentation.htm or by ordering at the local Danfoss office.

6.2.2 0-** Operation/Display

Parameters related to the fundamental functions of the frequency converter, function of the LCP keys and configuration of the LCP display.

0-01 Language		
Option:	Function:	
		Defines the language to be used in the display. The frequency converter can be delivered with 4 different language packages. English and German are included in all packages. English cannot be erased or manipulated.
[0] *	English	Part of Language packages 1 - 4
[1]	German	Part of Language packages 1 - 4
[2]	French	Part of Language package 1
[3]	Danish	Part of Language package 1
[4]	Spanish	Part of Language package 1
[5]	Italian	Part of Language package 1
[6]	Swedish	Part of Language package 1
[7]	Dutch	Part of Language package 1
[10]	Chinese	Language package 2
[20]	Finnish	Part of Language package 1
[22]	English US	Part of Language package 4
[27]	Greek	Part of Language package 4
[28]	Portuguese	Part of Language package 4
[36]	Slovenian	Part of Language package 3
[39]	Korean	Part of Language package 2
[40]	Japanese	Part of Language package 2
[41]	Turkish	Part of Language package 4
[42]	Traditional Chinese	Part of Language package 2
[43]	Bulgarian	Part of Language package 3
[44]	Serbian	Part of Language package 3
[45]	Romanian	Part of Language package 3
[46]	Hungarian	Part of Language package 3
[47]	Czech	Part of Language package 3
[48]	Polish	Part of Language package 4
[49]	Russian	Part of Language package 3
[50]	Thai	Part of Language package 2
[51]	Bahasa Indonesian	Part of Language package 2

0-20 Display Line 1.1 Small		
Option:	Function:	
		Select a variable for display in line 1, left position.
[0]	None	No display value selected
[37]	Display Text 1	Present control word
[38]	Display Text 2	Enables an individual text string to be written, for display in the LCP or to be read via serial communication.
[39]	Display Text 3	Enables an individual text string to be written, for display in the LCP or to be read via serial communication.
[89]	Date and Time Readout	Displays the current date and time.

0-20 Display Line 1.1 Small		
Option:	Function:	
[953]	Profibus Warning Word	Displays Profibus communication warnings.
[1005]	Readout Transmit Error Counter	View the number of CAN control transmission errors since the last power-up.
[1006]	Readout Receive Error Counter	View the number of CAN control receipt errors since the last power-up.
[1007]	Readout Bus Off Counter	View the number of bus-off events since the last power-up.
[1013]	Warning Parameter	View a DeviceNet-specific warning word. One separate bit is assigned to every warning.
[1230]	Warning Parameter	
[1397]	Alert Alarm Word	
[1398]	Alert Warning Word	
[1399]	Alert Status Word	
[1500]	Operating hours	View the number of running hours of the frequency converter.
[1501]	Running Hours	View the number of running hours of the motor.
[1502]	kWh Counter	View the mains power consumption in kWh.
[1580]	Fan Running Hours	
[1600]	Control Word	View the control word sent from the frequency converter via the serial communication port in hex code.
[1601]	Reference [Unit] *	Total reference (sum of digital/analog/preset/bus/freeze ref./catch up and slow-down) in selected unit.
[1602]	Reference [%]	Total reference (sum of digital/analog/preset/bus/freeze ref./catch up and slow-down) in percent.
[1603]	Status Word	Present status word.
[1605]	Main Actual Value [%]	One or more warnings in a hex code.
[1609]	Custom Readout	View the user-defined readouts as defined in <i>0-30 Custom Readout Unit</i> , <i>0-31 Custom Readout Min Value</i> and <i>0-32 Custom Readout Max Value</i> .
[1610]	Power [kW]	Actual power consumed by the motor in kW.
[1611]	Power [hp]	Actual power consumed by the motor in hp.
[1612]	Motor Voltage	Voltage supplied to the motor.

0-20 Display Line 1.1 Small		
Option:	Function:	
[1613]	Frequency	Motor frequency, i.e. the output frequency from the frequency converter in Hz.
[1614]	Motor current	Phase current of the motor measured as effective value.
[1615]	Frequency [%]	Motor frequency, i.e. the output frequency from the frequency converter in percent.
[1616]	Torque [Nm]	Present motor load as a percentage of the rated motor torque.
[1617]	Speed [RPM]	Speed in RPM (revolutions per minute) i.e. the motor shaft speed in closed loop based on the entered motor nameplate data, the output frequency and the load on the frequency converter.
[1618]	Motor Thermal	Thermal load on the motor, calculated by the ETR function. See also parameter group <i>1-9* Motor Temperature</i> .
[1622]	Torque [%]	Shows the actual torque produced in percentage.
[1626]	Power Filtered [kW]	
[1627]	Power Filtered [hp]	
[1630]	DC Link Voltage	Intermediate circuit voltage in the frequency converter.
[1632]	Brake Energy /s	Present brake power transferred to an external brake resistor. Stated as an instantaneous value.
[1633]	Brake Energy Average	Brake power transferred to an external brake resistor. The mean power is calculated continuously for the most recent 120 s.
[1634]	Heatsink Temp.	Present heat sink temperature of the frequency converter. The cut-out limit is 95 ± 5 °C; cutting back in occurs at 70 ± 5 °C.
[1635]	Inverter Thermal	Percentage load of the inverters.
[1636]	Inv. Nom. Current	Nominal current of the frequency converter.
[1637]	Inv. Max. Current	Maximum current of the frequency converter.
[1638]	SL Controller State	State of the event executed by the control.
[1639]	Control Card Temp.	Temperature of the control card.

0-20 Display Line 1.1 Small		
Option:	Function:	
[1650]	External Reference	Sum of the external reference as a percentage, i.e. the sum of analog/pulse/bus.
[1652]	Feedback[Unit]	Signal value in units from the programmed digital input(s).
[1653]	Digi Pot Reference	View the contribution of the digital potentiometer to the actual reference feedback.
[1654]	Feedback 1 [Unit]	View the value of feedback 1. See also parameter group 20-0* <i>Feedback</i> .
[1655]	Feedback 2 [Unit]	View the value of feedback 2. See also parameter group 20-0* <i>Feedback</i> .
[1656]	Feedback 3 [Unit]	View the value of feedback 3. See also parameter group 20-0* <i>Feedback</i> .
[1658]	PID Output [%]	Returns the drive closed loop PID controller output value in percent.
[1659]	Adjusted Setpoint	Displays the actual operating setpoint after it is modified by flow compensation. See parameter group 22-8* <i>Flow Compensation</i> .
[1660]	Digital Input	Displays the status of the digital inputs. Signal low=0; Signal high=1. Regarding order, see 16-60 <i>Digital Input</i> . Bit 0 is at the extreme right.
[1661]	Terminal 53 Switch Setting	Setting of input terminal 53. Current=0; Voltage=1.
[1662]	Analog Input 53	Actual value at input 53 either as a reference or protection value.
[1663]	Terminal 54 Switch Setting	Setting of input terminal 54. Current=0; Voltage=1.
[1664]	Analog Input 54	Actual value at input 54 either as reference or protection value.
[1665]	Analog Output 42 [mA]	Actual value at output 42 in mA. Use parameter 6-50 <i>Terminal 42 Output</i> to select the variable to be represented by output 42.
[1666]	Digital Output [bin]	Binary value of all digital outputs.
[1667]	Pulse Input #29 [Hz]	Actual value of the frequency applied at terminal 29 as a pulse input.
[1668]	Pulse Input #33 [Hz]	Actual value of the frequency applied at terminal 33 as a pulse input.
[1669]	Pulse Output #27 [Hz]	Actual value of pulses applied to terminal 27 in digital output mode.
[1670]	Pulse Output #29 [Hz]	Actual value of pulses applied to terminal 29 in digital output mode.
[1671]	Relay Output [bin]	View the setting of all relays.

0-20 Display Line 1.1 Small		
Option:	Function:	
[1672]	Counter A	View the present value of counter A.
[1673]	Counter B	View the present value of counter B.
[1675]	Analog In X30/11	Actual value of the signal on input X30/11 (General Purpose I/O Card. Option)
[1676]	Analog In X30/12	Actual value of the signal on input X30/12 (general purpose I/O card. Optional)
[1677]	Analog Out X30/8 [mA]	Actual value at output X30/8 (general purpose I/O card. Optional) Use 6-60 <i>Terminal X30/8 Output</i> to select the variable to be shown.
[1678]	Analog Out X45/1 [mA]	
[1679]	Analog Out X45/3 [mA]	
[1680]	Fieldbus CTW 1	Control word (CTW) received from the bus master.
[1682]	Fieldbus REF 1	Main reference value sent with control word via the serial communications network e.g. from the BMS, PLC or other master controller.
[1684]	Comm. Option STW	Extended fieldbus communication option status word.
[1685]	FC Port CTW 1	Control word (CTW) received from the bus master.
[1686]	FC Port REF 1	Status word (STW) sent to the bus master.
[1690]	Alarm Word	One or more alarms in a hex code (used for serial communication).
[1691]	Alarm Word 2	One or more alarms in a hex code (used for serial communication).
[1692]	Warning Word	One or more warnings in a hex code (used for serial communication).
[1693]	Warning Word 2	One or more warnings in a hex code (used for serial communication).
[1694]	Ext. Status Word	One or more status conditions in a hex code (used for serial communication).
[1695]	Ext. Status Word 2	One or more status conditions in a hex code (used for serial communication).
[1696]	Maintenance Word	The bits reflect the status for the programmed preventive maintenance events in parameter group 23-1* <i>Maintenance</i> .

0-20 Display Line 1.1 Small		
Option:	Function:	
[1830]	Analog Input X42/1	Shows the value of the signal applied to terminal X42/1 on the analog I/O card.
[1831]	Analog Input X42/3	Shows the value of the signal applied to terminal X42/3 on the analog I/O card.
[1832]	Analog Input X42/5	Shows the value of the signal applied to terminal X42/5 on the analog I/O card.
[1833]	Analog Out X42/7 [V]	Shows the value of the signal applied to terminal X42/7 on the analog I/O card.
[1834]	Analog Out X42/9 [V]	Shows the value of the signal applied to terminal X42/9 on the Analog I/O card.
[1835]	Analog Out X42/11 [V]	Shows the value of the signal applied to terminal X42/11 on the Analog I/O card.
[1836]	Analog Input X48/2 [mA]	
[1837]	Temp. Input X48/4	
[1838]	Temp. Input X48/7	
[1839]	Temp. Input X48/10	
[1850]	Sensorless Readout [unit]	
[1860]	Digital Input 2	
[2117]	Ext. 1 Reference [Unit]	The value of the reference for extended closed loop controller 1.
[2118]	Ext. 1 Feedback [Unit]	The value of the feedback signal for extended closed loop controller 1.
[2119]	Ext. 1 Output [%]	The value of the output from extended closed loop controller 1.
[2137]	Ext. 2 Reference [Unit]	The value of the reference for extended closed loop controller 2.
[2138]	Ext. 2 Feedback [Unit]	The value of the feedback signal for extended closed loop controller 2.
[2139]	Ext. 2 Output [%]	The value of the output from extended closed loop controller 2.
[2157]	Ext. 3 Reference [Unit]	The value of the reference for extended closed loop controller 3.
[2158]	Ext. 3 Feedback [Unit]	The value of the feedback signal for extended closed loop controller 3.
[2159]	Ext. 3 Output [%]	The value of the output from extended closed loop controller 3.

0-20 Display Line 1.1 Small		
Option:	Function:	
[2230]	No-Flow Power	The calculated no-flow power for the actual operating speed.
[2316]	Maintenance Text	
[2580]	Cascade Status	Status for the operation of the cascade controller.
[2581]	Pump Status	Status for the operation of each individual pump controlled by the cascade controller.
[2791]	Cascade Reference	Reference output for use with follower drives.
[2792]	% Of Total Capacity	Readout parameter to show the system operating point as a % capacity of total system capacity.
[2793]	Cascade Option Status	Readout parameter to show the status of the cascade system.
[2794]	Cascade System Status	
[2795]	Advanced Cascade Relay Output [bin]	
[2796]	Extended Cascade Relay Output [bin]	
[2920]	Derag Power[kW]	
[2921]	Derag Power[HP]	
[3110]	Bypass Status Word	
[3111]	Bypass Running Hours	
[9920]	HS Temp. (PC1)	
[9921]	HS Temp. (PC2)	
[9922]	HS Temp. (PC3)	
[9923]	HS Temp. (PC4)	
[9924]	HS Temp. (PC5)	
[9925]	HS Temp. (PC6)	
[9926]	HS Temp. (PC7)	
[9927]	HS Temp. (PC8)	
[9951]	PC Debug 0	
[9952]	PC Debug 1	
[9953]	PC Debug 2	
[9954]	PC Debug 3	
[9955]	PC Debug 4	
[9956]	Fan 1 Feedback	
[9957]	Fan 2 Feedback	
[9958]	PC Auxiliary Temp	
[9959]	Power Card Temp.	

0-21 Display Line 1.2 Small		
Option:	Function:	
		Select a variable for display in line 1, middle position.
[1662] *	Analog input 53	The options are the same as those listed for par. 0-20 <i>Display Line 1.1 Small</i> .

0-22 Display Line 1.3 Small		
Option:	Function:	
		Select a variable for display in line 1, right position.
[1614] *	Motor Current	The options are the same as those listed for 0-20 <i>Display Line 1.1 Small</i> .

0-23 Display Line 2 Large		
Option:	Function:	
		Select a variable for display in line 2.
[1615] *	Frequency	The options are the same as those listed for par. 0-20 <i>Display Line 1.1 Small</i>

0-24 Display Line 3 Large		
Option:	Function:	
[1652] *	Feedback [Unit]	The options are the same as those listed for 0-20 <i>Display Line 1.1 Small</i> .
		Select a variable for display in line 2.

0-37 Display Text 1		
Range:	Function:	
0* [0 - 25]	In this parameter, it is possible to write an individual text string for display in the LCP or to be read via serial communication. If to be displayed permanently, select Display Text 1 in 0-20 <i>Display Line 1.1 Small</i> , 0-21 <i>Display Line 1.2 Small</i> , 0-22 <i>Display Line 1.3 Small</i> , 0-23 <i>Display Line 2 Large</i> or 0-24 <i>Display Line 3 Large</i> . Parameter 0-37 is linked to Parameter 12-08 Host Name. Changing Parameter 12-08 will change Parameter 0-37 - but not in the other direction.	

0-38 Display Text 2		
Range:	Function:	
0* [0 - 25]	In this parameter, it is possible to write an individual text string for display in the LCP or to be read via serial communication. If to be displayed permanently, select Display Text 2 in 0-20 <i>Display Line 1.1 Small</i> , 0-21 <i>Display Line 1.2 Small</i> , 0-22 <i>Display Line 1.3 Small</i> , 0-23 <i>Display Line 2 Large</i> or 0-24 <i>Display Line 3 Large</i> . Press [▲] or [▼] to change a character. Press [◀] and [▶] to move the cursor. When a character is highlighted by the cursor, this character can be changed. A character can be inserted by placing the cursor between 2 characters and pressing [▲] or [▼].	

0-39 Display Text 3		
Range:	Function:	
0* [0 - 25]	In this parameter it is possible to write an individual text string for display in the LCP or to be read via serial communication. If to be displayed permanently select Display Text 3 in 0-20 <i>Display Line 1.1 Small</i> , 0-21 <i>Display Line 1.2 Small</i> , 0-22 <i>Display Line 1.3 Small</i> , 0-23 <i>Display Line 2 Large</i> or 0-24 <i>Display Line 3 Large</i> . Press [▲] or [▼] to change a character. Press [◀] and [▶] to move the cursor. When a character is highlighted by the cursor, this character can be changed. A character can be inserted by placing the cursor between 2 characters and pressing [▲] or [▼].	

0-70 Date and Time		
Range:	Function:	
Size related*	[0 - 0]	Sets the date and time of the internal clock. The format to be used is set in 0-71 <i>Date Format</i> and parameter 0-72 <i>Time Format</i> .

0-71 Date Format		
Option:	Function:	
[0]	YYYY-MM-DD	Sets the date format to be used in the LCP.
[1]	DD-MM-YYYY	Sets the date format to be used in the LCP.
[2]	MM/DD/YYYY	Sets the date format to be used in the LCP.

0-72 Time Format		
Option:	Function:	
		Sets the time format to be used in the LCP.
[0]	24 h	
[1]	12 h	

0-74 DST/Summertime		
Option:	Function:	
		Select how daylight saving time/summertime should be handled. For manual DST/summertime enter the start date and end date in parameter 0-76 <i>DST/Summertime Start</i> and parameter 0-77 <i>DST/Summertime End</i> .
[0] *	Off	
[2]	Manual	

0-76 DST/Summertime Start		
Range:	Function:	
Size related*	[0 - 0]	Sets the date and time when DST/summertime starts. The date is programmed in the format selected in 0-71 <i>Date Format</i> .

0-77 DST/Summertime End		
Range:		Function:
Size related*	[0 - 0]	Sets the date and time when DST/summertime ends. The date is programmed in the format selected in 0-71 Date Format.

6.2.3 1-0* General Settings

Define whether the frequency converter operates in open loop or closed loop.

1-00 Configuration Mode		
Option:	Function:	
		NOTICE This parameter cannot be adjusted while the motor is running.
[0]	Open Loop	Motor speed is determined by applying a speed reference or by setting desired speed when in Hand Mode. Open loop is also used if the frequency converter is of a closed loop control system based on an external PID controller providing a speed reference signal as output.
[3]	Closed Loop	Motor speed is determined by a reference from the built-in PID controller varying the motor speed as of a closed loop control process (e.g. constant pressure or flow). The PID controller must be configured in parameter group 20-** Feedback or via the Function Set-ups accessed by pressing [Quick Menus].

NOTICE

When set for closed loop, the commands reversing and start reversing do not reverse the motor direction.

1-20 Motor Power [kW]		
Range:		Function:
Size related*	[0.09 - 2000.00 kW]	Enter the nominal motor power in kW according to the motor nameplate data. The default value corresponds to the nominal rated output of the unit. Depending on the selections made in 0-03 Regional Settings, either parameter 1-20 Motor Power [kW] or 1-21 Motor Power [HP] is made invisible.

1-22 Motor Voltage		
Range:		Function:
Size related*	[10 - 1000 V]	Enter the nominal motor voltage according to the motor nameplate data. The default value corresponds to

1-22 Motor Voltage		
Range:		Function:
		the nominal rated output of the frequency converter.

1-23 Motor Frequency		
Range:		Function:
Size related*	[20 - 1000 Hz]	Select the motor frequency value from the motor nameplate data. For 87 Hz operation with 230/400 V motors, set the nameplate data for 230 V/50 Hz. Adapt parameter 4-13 Motor Speed High Limit [RPM] and 3-03 Maximum Reference to the 87 Hz application.

1-24 Motor Current		
Range:		Function:
Size related*	[0.10 - 10000.00 A]	Enter the nominal motor current value from the motor nameplate data. This data is used for calculating motor torque, thermal motor protection etc.

1-25 Motor Nominal Speed		
Range:		Function:
Size related*	[100 - 60000 RPM]	Enter the nominal motor speed value from the motor nameplate data. This data is used for calculating automatic motor compensations.

1-29 Automatic Motor Adaptation (AMA)		
Option:	Function:	
		NOTICE This parameter cannot be adjusted while the motor is running.
[0] *	Off	No function
[1]	Enable Complete AMA	Performs AMA of the stator resistance R_s , the rotor resistance R_r , the stator leakage reactance X_1 , the rotor leakage reactance X_2 and the main reactance X_h .
[2]	Enable Reduced AMA	Performs a reduced AMA of the stator resistance R_s in the system only. Select this option if an LC filter is used between the frequency converter and the motor.

NOTICE

Parameter 1-29 Automatic Motor Adaptation (AMA) have no effect when 1-10 Motor Construction = [1] PM, non-salient SPM.

Activate the AMA function by pressing [Hand On] after selecting [1] or [2]. See also the section Automatic Motor Adaptation in the Design Guide. After a normal sequence, the display reads: Press [OK] to finish AMA. After pressing [OK], the frequency converter is ready for operation.

NOTICE

- For the best adaptation of the frequency converter, run AMA on a cold motor
- AMA cannot be performed while the motor is running

NOTICE

Avoid generating external torque during AMA.

NOTICE

If one of the settings in parameter group 1-2* Motor Data is changed, 1-30 Stator Resistance (Rs) to 1-39 Motor Poles return to default settings.

NOTICE

Full AMA should be run without filter only while reduced AMA should be run with filter.

See section: Application Examples > Automatic Motor Adaptation in the Design Guide.

6.2.4 3-0* Reference Limits

3-02 Minimum Reference		
Range:		Function:
Size related*	[-999999.999 - par. 3-03 ReferenceFeed-backUnit]	Enter the minimum reference. The minimum reference is the lowest value obtainable by summing all references. The minimum reference value and unit matches the configuration made in parameter 1-00 Configuration Mode and 20-12 Reference/Feedback Unit.
<p>NOTICE</p> <p>This parameter is used in open loop only.</p>		

3-04 Reference Function		
Option:		Function:
[0] *	Sum	Sums both external and preset reference sources.
[1]	External/ Preset	Use either the preset or the external reference source. Shift between external and preset via a command on a digital input.

3-10 Preset Reference		
Array [8]		
Range:		Function:
0 %*	[-100 - 100 %]	Enter up to 8 different preset references (0-7) in this parameter, using array programming. The preset reference is stated as a percentage of the value Ref _{MAX} (3-03 Maximum Reference, for closed loop see 20-14 Maximum Reference/ Feedb.). When using preset references, select Preset ref. bit 0/1/2 [16], [17] or [18] for the corresponding digital inputs in parameter group 5-1* Digital Inputs.

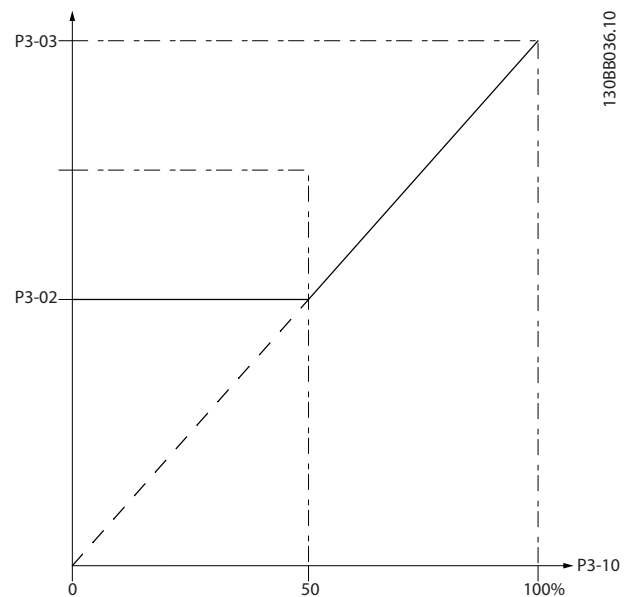

Illustration 6.11 Preset Reference

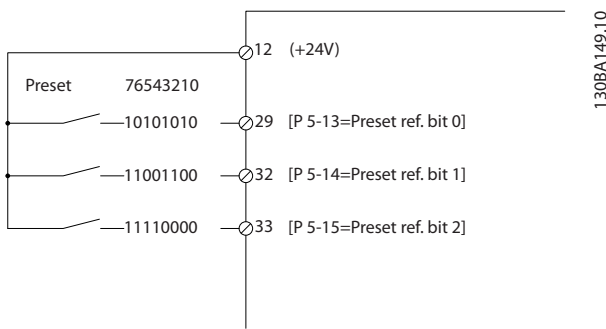

Illustration 6.12 Preset Reference Scheme

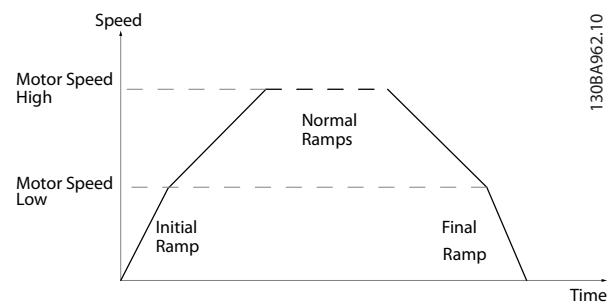

Illustration 6.13 Initial and Final Ramp Time

6

3-41 Ramp 1 Ramp Up Time		
Range:	Function:	
Size related*	[0.10 - 3600 s]	Enter the ramp-up time, that is, the acceleration time from 0 RPM to <i>parameter 1-25 Motor Nominal Speed</i> . Select a ramp-up time such that the output current does not exceed the current limit in <i>4-18 Current Limit</i> during ramping. See ramp-down time in <i>parameter 3-42 Ramp 1 Ramp Down Time</i> .

$$par.3 - 41 = \frac{t_{acc} \times n_{nom} [par.1 - 25]}{ref [RPM]} [s]$$

3-42 Ramp 1 Ramp Down Time		
Range:	Function:	
Size related*	[0.10 - 3600 s]	Enter the ramp-down time, that is, the deceleration time from <i>parameter 1-25 Motor Nominal Speed</i> to 0 RPM. Select a ramp-down time preventing overvoltage from arising in the inverter due to regenerative operation of the motor. The ramp-down time should also be long enough to prevent that the generated current exceeds the current limit set in <i>4-18 Current Limit</i> . See ramp-up time in <i>parameter 3-41 Ramp 1 Ramp Up Time</i> .

$$par.3 - 42 = \frac{t_{dec} \times n_{nom} [par.1 - 25]}{ref [RPM]} [s]$$

3-84 Initial Ramp Time		
Range:	Function:	
0 s*	[0 - 60 s]	Enter the initial ramp-up time from zero speed to motor speed low limit, <i>parameter 4-11 Motor Speed Low Limit [RPM]</i> or <i>4-12 Motor Speed Low Limit [Hz]</i> . Submersible deep-well pumps can be damaged by running below minimum speed. A fast ramp time below minimum pump speed is recommended. This parameter may be applied as a fast ramp rate from zero speed to motor speed low limit. See <i>Illustration 6.13</i> .

3-85 Check Valve Ramp Time		
Range:	Function:	
0 s*	[0 - 60 s]	To protect ball check valves in a stop situation, the check valve ramp can be utilised as a slow ramp rate from <i>parameter 4-11 Motor Speed Low Limit [RPM]</i> or <i>4-12 Motor Speed Low Limit [Hz]</i> , to check valve ramp end speed, set by the user in <i>3-86 Check Valve Ramp End Speed [RPM]</i> or <i>3-87 Check Valve Ramp End Speed [HZ]</i> . When <i>3-85 Check Valve Ramp Time</i> is different from 0 s, the check valve ramp time is effectuated and is used to ramp down the speed from motor speed low limit to the check valve end speed in <i>3-86 Check Valve Ramp End Speed [RPM]</i> or <i>3-87 Check Valve Ramp End Speed [HZ]</i> . See <i>Illustration 6.14</i> .

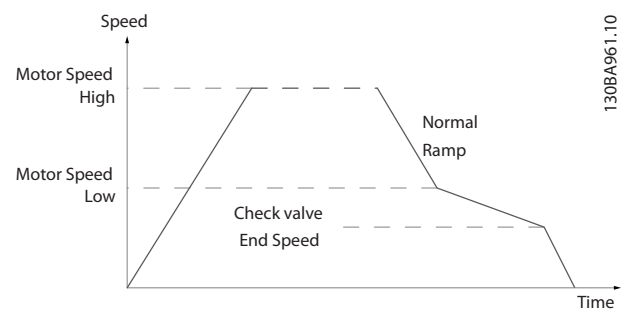

Illustration 6.14 Check Valve Ramp

3-86 Check Valve Ramp End Speed [RPM]		
Range:	Function:	
Size related*	[0 - par. 4-11 RPM]	Set the speed in [RPM] below Motor Speed Low Limit where the Check Valve is expected to be closed and the Check Valve should no longer be active.

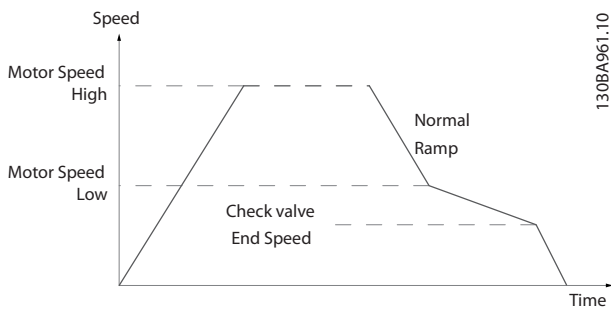

Illustration 6.15

3-87 Check Valve Ramp End Speed [Hz]		
Range:	Function:	
Size related*	[0 - par. 4-12 Hz]	Set the speed in [Hz] below Motor Speed Low Limit where the Check Valve Ramp should no longer be active.

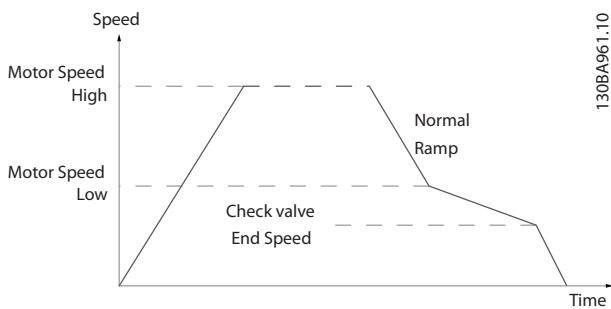

Illustration 6.16

3-88 Final Ramp Time		
Range:	Function:	
0 s*	[0 - 60 s]	Enter the Final Ramp Time to be used when ramping down from Motor Speed Low Limit, parameter 4-11 Motor Speed Low Limit [RPM] or 4-12 Motor Speed Low Limit [Hz], to zero speed. Submersible deep well pumps can be damaged by running below minimum speed. A fast ramp time below minimum pump speed is recommended. This parameter may be applied as a fast ramp rate from Motor Speed Low Limit to zero speed.

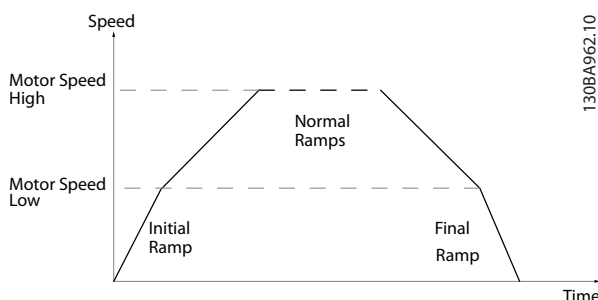

Illustration 6.17

4-11 Motor Speed Low Limit [RPM]		
Range:	Function:	
Size related*	[0 - par. 4-13 RPM]	Enter the minimum limit for motor speed in RPM. The motor speed low limit can be set to correspond to the manufacturer's recommended minimum motor speed. The motor speed low limit must not exceed the setting in parameter 4-13 Motor Speed High Limit [RPM].

4-13 Motor Speed High Limit [RPM]		
Range:	Function:	
Size related*	[0 - 60000 RPM]	Enter the maximum limit for motor speed in RPM. The motor speed high limit can be set to correspond to the manufacturer's maximum rated motor. The motor speed high limit must exceed the setting in parameter 4-11 Motor Speed Low Limit [RPM]. The parameter name appears as either parameter 4-11 Motor Speed Low Limit [RPM] or 4-12 Motor Speed Low Limit [Hz], depending on <ul style="list-style-type: none"> the settings of other parameters in the Main Menu, and default settings based on geographical location.

NOTICE

Max. output frequency cannot exceed 10% of the inverter switching frequency (14-01 Switching Frequency).

NOTICE

Any changes in parameter 4-13 Motor Speed High Limit [RPM] reset the value in 4-53 Warning Speed High to the same value as set in parameter 4-13 Motor Speed High Limit [RPM].

Parameter group for configuring the digital input and output.

5-01 Terminal 27 Mode		
Option:	Function:	
	NOTICE This parameter cannot be adjusted while the motor is running.	
[0] *	Input	Defines terminal 27 as a digital input.
[1]	Output	Defines terminal 27 as a digital output.

6.2.5 5-1* Digital Inputs

Parameters for configuring the input functions for the input terminals.

The digital inputs are used for selecting various functions in the frequency converter. All digital inputs can be set to the following functions:

Options [120] - [138] are related to the cascade controller functionality. For more information, see parameter group 25-** *Cascade Controller*.

Digital input function	Option	Terminal
No operation	[0]	All *term 32, 33, 29, 19
Reset	[1]	All
Coast inverse	[2]	All * term 27
Coast and reset inverse	[3]	All
DC-brake inverse	[5]	All
Stop inverse	[6]	All
External interlock	[7]	All
Start	[8]	All
Latched start	[9]	All
Reversing	[10]	All
Start reversing	[11]	All
Jog	[14]	All
Preset reference on	[15]	All
Preset ref bit 0	[16]	All
Preset ref bit 1	[17]	All
Preset ref bit 2	[18]	All
Freeze reference	[19]	All
Freeze output	[20]	All
Speed up	[21]	All
Speed down	[22]	All
Set-up select bit 0	[23]	All
Set-up select bit 1	[24]	All
Pulse input	[32]	term 29, 33
Ramp bit 0	[34]	All
Mains failure inverse	[36]	All
Ref source bit 0	[42]	All
Hand/auto start	[51]	All
Run permissive	[52]	All
Hand start	[53]	All
Auto start	[54]	All
DigiPot increase	[55]	All
DigiPot decrease	[56]	All
DigiPot clear	[57]	All
Counter A (up)	[60]	29, 33
Counter A (down)	[61]	29, 33
Reset counter A	[62]	All
Counter B (up)	[63]	29, 33
Counter B (down)	[64]	29, 33
Reset counter B	[65]	All
Sleep mode	[66]	All
Reset maintenance word	[78]	All

Digital input function	Option	Terminal
PTC card 1	[80]	All
Latched pump derag	[85]	All
Lead pump start	[120]	All
Lead pump alternation	[121]	All
Pump 1 interlock	[130]	All
Pump 2 interlock	[131]	All
Pump 3 interlock	[132]	All

Table 6.7 Functions for Digital Inputs

All = Terminals 18, 19, 27, 29, 32, X30/2, X30/3, X30/4. X30/ are the terminals on MCB 101.

Functions dedicated to only one digital input are stated in the associated parameter.

All digital inputs can be programmed to these functions:

[0]	No operation	No reaction to signals transmitted to terminal.
[1]	Reset	Resets frequency converter after a TRIP/ALARM. Not all alarms can be reset.
[2]	Coast inverse	Leaves motor in free mode. Logic '0' ⇒ coasting stop. (Default Digital input 27): Coasting stop, inverted input (NC).
[3]	Coast and reset inverse	Reset and coasting stop inverted input (NC). Leaves motor in free mode and resets the frequency converter. Logic '0' ⇒ coasting stop and reset.
[5]	DC-brake inverse	Inverted input for DC braking (NC). Stops motor by energising it with a DC current for a certain time period. See 2-01 DC Brake Current to 2-03 DC Brake Cut In Speed [RPM]. The function is only active when the value in 2-02 DC Braking Time is different from 0. Logic '0' ⇒ DC braking. This selection is not possible when 1-10 Motor Construction is set to [1] PM, non salient SPM.
[6]	Stop inverse	Stop inverted function. Generates a stop function when the selected terminal goes from logical level '1' to '0'. The stop is performed according to the selected ramp time (parameter 3-42 Ramp 1 Ramp Down Time and 3-52 Ramp 2 Ramp Down Time). NOTICE When the frequency converter is at the torque limit and has received a stop command, it may not stop by itself. To ensure that the frequency converter stops, configure a digital output to [27] Torque limit & stop and connect this digital output to a digital input that is configured as coast.

[7]	External Interlock	Same function as Coasting stop, inverse, but External Interlock generates the alarm message <i>external fault</i> in the display when the terminal which is programmed for Coast Inverse is logic '0'. The alarm message is also active via digital outputs and relay outputs, if programmed for External Interlock. The alarm can be reset using a digital input or the [Reset] key if the cause for the external interlock has been removed. A delay can be programmed in <i>22-00 External Interlock Delay</i> . After applying a signal to the input, the reaction described above is delayed with the time set in <i>22-00 External Interlock Delay</i> .
[8]	Start	Select start value for a start/stop command. '1'=start, '0'=stop. (Default Digital input 18)
[9]	Latched start	Motor starts, if a pulse is applied for min. 2 ms. Motor stops when Stop inverse is activated
[10]	Reversing	Changes direction of motor shaft rotation. Select Logic '1' to reverse. The reversing signal only changes the direction of rotation. It does not activate the start function. Select both directions in <i>4-10 Motor Speed Direction</i> . (Default Digital input 19).
[11]	Start reversing	Used for start/stop and for reversing on the same wire. Signals on start are not allowed at the same time.
[14]	Jog	Used for activating jog speed. See <i>3-11 Jog Speed [Hz]</i> . (Default Digital input 29)
[15]	Preset reference on	Used for shifting between external reference and preset reference. It is assumed that [1] <i>External/preset</i> has been selected in <i>parameter 3-04 Reference Function</i> . Logic '0' = external reference active; logic '1' = one of the 8 preset references is active.
[16]	Preset ref bit 0	Enables a selection of one of the 8 preset references according to <i>Table 6.8</i> .
[17]	Preset ref bit 1	Enables a selection of one of the 8 preset references according to <i>Table 6.8</i> .
[18]	Preset ref bit 2	Enables a selection of one of the 8 preset references according to <i>Table 6.8</i> .

Preset ref. bit	2	1	0
Preset ref. 0	0	0	0
Preset ref. 1	0	0	1
Preset ref. 2	0	1	0
Preset ref. 3	0	1	1
Preset ref. 4	1	0	0
Preset ref. 5	1	0	1
Preset ref. 6	1	1	0
Preset ref. 7	1	1	1

Table 6.8 Preset Ref. Bit

[19]	Freeze ref	Freezes actual reference. The frozen reference is now the point of enable/condition for speed up and speed down to be used. If speed up/down is used, the speed change always follows ramp 2 (<i>3-51 Ramp 2 Ramp Up Time</i> and <i>3-52 Ramp 2 Ramp Down Time</i>) in the range 0 - <i>3-03 Maximum Reference Maximum Reference</i> .
[20]	Freeze output	Freezes actual motor frequency (Hz). The frozen motor frequency is now the point of enable/condition for speed up and speed down to be used. If speed up/down is used, the speed change always follows ramp 2 (<i>3-51 Ramp 2 Ramp Up Time</i> and <i>3-52 Ramp 2 Ramp Down Time</i>) in the range 0 - <i>parameter 1-23 Motor Frequency</i> . NOTICE When [20] Freeze output is active, the frequency converter cannot be stopped via a low 'start [13]' signal. Stop the frequency converter via a terminal programmed for [2] Coast inverse or [3] Coast and reset, inverse.
[21]	Speed up	For digital control of the up/down speed (motor potentiometer). Activate this function by selecting either [19] Freeze reference or [20] Freeze output. When [21] Speed up is activated for less than 400 ms the resulting reference is increased by 0.1%. If [21] Speed up is activated for more than 400 ms, the resulting reference ramps according to Ramp 1 in <i>parameter 3-41 Ramp 1 Ramp Up Time</i> .
[22]	Speed down	Same as [21] Speed up.
[23]	Set-up select bit 0	Selects one of the 4 set-ups. Set <i>0-10 Active Set-up</i> to Multi Set-up.
[24]	Set-up select bit 1	Same as [23] Set-up select bit 0. (Default Digital input 32)
[32]	Pulse input	Select [32] Pulse input when using a pulse sequence as either reference or feedback. Scaling is done in parameter group 5-5* <i>Pulse Input</i> .

[34]	Ramp bit 0	Select which ramp to use. Logic '0' selects ramp 1 while logic '1' selects ramp 2.
[36]	Mains failure inverse	Activates <i>14-10 Mains Failure</i> . Mains failure inverse is active in the Logic '0' situation.
[42]	Ref source bit 0	An active input in bit 0 selects AI54 as the reference source (see parameter group 3-1* <i>References</i> , option [35] <i>Digital input select</i>). An inactive input selects AI53.
[51]	Hand/Auto Start	Selects Hand or Auto Start. High = Auto On only, Low = Hand on only.
[52]	Run Permissive	The input terminal, for which the [52] <i>Run Permissive</i> has been programmed must be logic '1' before a start command can be accepted. Run permissive has a logic 'AND' function related to the terminal which is programmed for [8] <i>Start</i> , [14] <i>Jog</i> or [20] <i>Freeze Output</i> . This means that to start running the motor, both conditions must be fulfilled. If [52] <i>Run Permissive</i> is programmed on multiple terminals, it only needs to be logic '1' on one of the terminals to carry out the function. The digital output signal for Run Request ([8] <i>Start</i> , [14] <i>Jog</i> or [20] <i>Freeze output</i>) programmed in parameter group 5-3* <i>Digital Outputs</i> , or parameter group 5-4* <i>Relays</i> , is not affected by [52] <i>Run Permissive</i> .
[53]	Hand start	A signal applied puts the frequency converter into Hand mode as if [Hand On] has been pressed and a normal stop command is overridden. If disconnecting the signal, the motor stops. To make any other start commands valid, assign another digital input to <i>Auto Start</i> and apply a signal to this. [Hand On] and [Auto On] have no impact. [Off] overrides <i>Hand Start</i> and <i>Auto Start</i> . Press either [Hand On] or [Auto On] to make <i>Hand Start</i> and <i>Auto Start</i> active again. If there is no signal on neither <i>Hand Start</i> nor <i>Auto Start</i> , the motor stops regardless of any normal Start command applied. If a signal is applied to both <i>Hand Start</i> and <i>Auto Start</i> , the function is <i>Auto Start</i> . If pressing [Off], the motor stops regardless of signals on <i>Hand Start</i> and <i>Auto Start</i> .
[54]	Auto start	A signal applied puts the frequency converter into Auto mode as if [Auto On] has been pressed. See also [53] <i>Hand Start</i> .
[55]	DigiPot Increase	Uses the input as an INCREASE signal to the digital potentiometer function described in parameter group 3-9* <i>Digital Pot.Meter</i> .
[56]	DigiPot Decrease	Uses the input as a DECREASE signal to the digital potentiometer function described in parameter group 3-9* <i>Digital Pot.Meter</i>
[57]	DigiPot Clear	Uses the input to CLEAR the digital potentiometer reference described in parameter group 3-9* <i>Digital Pot.Meter</i>

[60]	Counter A (up)	(Terminal 29 or 33 only) Input for increment counting in the SLC counter.
[61]	Counter A (down)	(Terminal 29 or 33 only) Input for decrement counting in the SLC counter.
[62]	Reset Counter A	Input for reset of counter A.
[63]	Counter B (up)	(Terminal 29 and 33 only) Input for increment counting in the SLC counter.
[64]	Counter B (down)	(Terminal 29 and 33 only) Input for decrement counting in the SLC counter.
[65]	Reset Counter B	Input for reset of counter B.
[66]	Sleep Mode	Forces the frequency converter into sleep mode (see parameter group 22-4* <i>Sleep Mode</i>). Reacts on the rising edge of signal applied.
[78]	Reset Preventive Maintenance Word	Resets all data in <i>16-96 Maintenance Word</i> to 0.
[80]	PTC Card1	All digital inputs can be set to [80] <i>PTC Card 1</i> . However, only one digital input must be set to this option.
[85]	Latched Pump Derag	Starts deragging.

Options [120] - [138] are related to the cascade controller functionality. For more information, see parameter group 25-** *Cascade Controller*.

[120]	Lead Pump Start	Starts/stops the lead pump (controlled by the frequency converter). A start also requires applying a system start signal e.g. to one of the digital inputs set for [8] <i>Start</i> .
[121]	Lead Pump Alternation	Forces alternation of the lead pump in a cascade controller. <i>25-50 Lead Pump Alternation</i> must be set to either [2] <i>At Command</i> or [3] <i>At Staging or At Command</i> . <i>25-51 Alternation Event</i> can be set to any of the 4 options.
[130] - [138]	Pump1 Interlock - Pump9 Interlock	The function depends on the setting in <i>25-06 Number of Pumps</i> . If set to [0] <i>No</i> , then Pump1 refers to the pump controlled by RELAY1 etc. If set to [1] <i>Yes</i> , Pump1 refers to the pump controlled by the frequency converter only (without any of the built-in relays involved) and Pump2 to the pump controlled by the relay RELAY1. Variable speed pump (lead) cannot be interlocked in the basic cascade controller. See <i>Table 6.9</i>

Setting in parameter group 5-1*	Setting in 25-06 Number of Pumps	
	[0] No	[1] Yes
[130] Pump1 Interlock	Controlled by RELAY1 (only if not lead pump)	Frequency converter controlled (cannot be interlocked)
[131] Pump2 Interlock	Controlled by RELAY2	Controlled by RELAY1
[132] Pump3 Interlock	Controlled by RELAY3	Controlled by RELAY2
[133] Pump4 Interlock	Controlled by RELAY4	Controlled by RELAY3
[134] Pump5 Interlock	Controlled by RELAY5	Controlled by RELAY4
[135] Pump6 Interlock	Controlled by RELAY6	Controlled by RELAY5
[136] Pump7 Interlock	Controlled by RELAY7	Controlled by RELAY6
[137] Pump8 Interlock	Controlled by RELAY8	Controlled by RELAY7
[138] Pump9 Interlock	Controlled by RELAY9	Controlled by RELAY8

5-13 Terminal 29 Digital Input

Option:	Function:
[0] * No Operation	Same options and functions as parameter group 5-1* <i>Digital Inputs</i> .

5-14 Terminal 32 Digital Input

The parameter contains all options and functions listed in parameter group 5-1* *Digital Inputs* except for option [32] *Pulse input*.

5-15 Terminal 33 Digital Input

The parameter contains all options and functions listed in parameter group 5-1* *Digital Inputs*.

5-30 Terminal 27 Digital Output

Option:	Function:
[0] * No operation	
[1] Control Ready	
[2] Drive ready	
[3] Drive rdy/rem ctrl	
[4] Stand-by / no warning	
[5] Running	
[6] Running / no warning	
[8] Run on ref/no warn	
[9] Alarm	
[10] Alarm or warning	
[11] At torque limit	
[12] Out of current range	
[13] Below current, low	
[14] Above current, high	

5-30 Terminal 27 Digital Output

Option:	Function:
[15] Out of speed range	
[16] Below speed, low	
[17] Above speed, high	
[18] Out of feedb. range	
[19] Below feedback, low	
[20] Above feedback, high	
[21] Thermal warning	
[25] Reverse	
[26] Bus OK	
[27] Torque limit & stop	
[28] Brake, no brake war	
[29] Brake ready, no fault	
[30] Brake fault (IGBT)	
[33] Safe stop active	
[35] External Interlock	
[40] Out of ref range	
[41] Below reference, low	
[42] Above ref, high	
[45] Bus ctrl.	
[46] Bus ctrl, 1 if timeout	
[47] Bus ctrl, 0 if timeout	
[55] Pulse output	
[60] Comparator 0	
[61] Comparator 1	
[62] Comparator 2	
[63] Comparator 3	
[64] Comparator 4	
[65] Comparator 5	
[70] Logic rule 0	
[71] Logic rule 1	
[72] Logic rule 2	
[73] Logic rule 3	
[74] Logic rule 4	
[75] Logic rule 5	
[80] SL digital output A	
[81] SL digital output B	
[82] SL digital output C	
[83] SL digital output D	
[84] SL digital output E	
[85] SL digital output F	
[90] kWh counter pulse	Creates a pulse on the digital output every time the frequency converter uses 1 kWh.
[155] Verifying Flow	
[160] No alarm	
[161] Running reverse	
[164] Local ref active, not OFF	
[165] Local ref active	
[166] Remote ref active	
[167] Start command activ	
[168] Hand mode	
[169] Auto mode	

5-30 Terminal 27 Digital Output	
Option:	Function:
[180]	Clock Fault
[181]	Prev. Maintenance
[182]	Deragging
[183]	Pre/Post Lube
[188]	AHF Capacitor Connect
[189]	External Fan Control
[190]	No-Flow
[191]	Dry Pump
[192]	End Of Curve
[193]	Sleep Mode
[194]	Broken Belt
[195]	Bypass Valve Control
[198]	Drive Bypass
[199]	Pipe Filling
[200]	Full capacity
[201]	Pump 1 running
[202]	Pump 2 running
[203]	Pump 3 running
[204]	Pump 4 running
[205]	Pump 5 running
[206]	Pump 6 running
[207]	Pump 7 running
[208]	Pump 8 running
[209]	Pump 9 running

5-40 Function Relay	
Option:	Function:
	Select options to define the function of the relays. The selection of each mechanical relay is realised in an array parameter.
[0]	No operation
[1]	Control Ready
[2]	Drive ready
[3]	Drive rdy/rem ctrl
[4]	Stand-by / no warning
[5]	Running
[6]	Running / no warning
[8]	Run on ref/no warn
[9]	Alarm
[10]	Alarm or warning
[11]	At torque limit
[12]	Out of current range
[13]	Below current, low
[14]	Above current, high
[15]	Out of speed range
[16]	Below speed, low
[17]	Above speed, high
[18]	Out of feedb. range
[19]	Below feedback, low
[20]	Above feedback, high

5-40 Function Relay	
Option:	Function:
[21]	Thermal warning
[25]	Reverse
[26]	Bus OK
[27]	Torque limit & stop
[28]	Brake, no brake war
[29]	Brake ready, no fault
[30]	Brake fault (IGBT)
[33]	Safe stop active
[35]	External Interlock
[36]	Control word bit 11
[37]	Control word bit 12
[40]	Out of ref range
[41]	Below reference, low
[42]	Above ref, high
[45]	Bus ctrl.
[46]	Bus ctrl, 1 if timeout
[47]	Bus ctrl, 0 if timeout
[60]	Comparator 0
[61]	Comparator 1
[62]	Comparator 2
[63]	Comparator 3
[64]	Comparator 4
[65]	Comparator 5
[70]	Logic rule 0
[71]	Logic rule 1
[72]	Logic rule 2
[73]	Logic rule 3
[74]	Logic rule 4
[75]	Logic rule 5
[80]	SL digital output A
[81]	SL digital output B
[82]	SL digital output C
[83]	SL digital output D
[84]	SL digital output E
[85]	SL digital output F
[155]	Verifying Flow
[160]	No alarm
[161]	Running reverse
[164]	Local ref active, not OFF
[165]	Local ref active
[166]	Remote ref active
[167]	Start command activ
[168]	Hand mode
[169]	Auto mode
[180]	Clock Fault
[181]	Prev. Maintenance
[183]	Pre/Post Lube
[188]	AHF Capacitor Connect
[189]	External Fan Control
[190]	No-Flow
[191]	Dry Pump
[192]	End Of Curve

5-40 Function Relay	
Option:	Function:
[193]	Sleep Mode
[194]	Broken Belt
[195]	Bypass Valve Control
[198]	Drive Bypass
[199]	Pipe Filling
[211]	Cascade Pump 1
[212]	Cascade Pump 2
[213]	Cascade Pump 3
[214]	Cascade Pump 4
[215]	Cascade Pump 5
[216]	Cascade Pump 6
[217]	Cascade Pump 7
[218]	Cascade Pump 8
[219]	Cascade Pump 9
[230]	Ext. Cascade Ctrl

5-53 Term. 29 High Ref./Feedb. Value	
Range:	Function:
100* [-999999.999 - 999999.999]	Enter the high reference value [RPM] for the motor shaft speed and the high feedback value, see also 5-58 Term. 33 High Ref./Feedb. Value.

6.2.6 6-** Analog In/Out

Parameter group for configuration of the analog input and output.

6-00 Live Zero Timeout Time	
Range:	Function:
10 s* [1 - 99 s]	Enter the live zero time-out time period. Live zero time-out time is active for analog inputs, that is, terminal 53 or terminal 54, used as reference or feedback sources. If the reference signal value associated with the selected current input drops below 50% of the value set in <i>parameter 6-10 Terminal 53 Low Voltage</i> , <i>6-12 Terminal 53 Low Current</i> , <i>parameter 6-20 Terminal 54 Low Voltage</i> or <i>6-22 Terminal 54 Low Current</i> for a time period longer than the time set in <i>parameter 6-00 Live Zero Timeout Time</i> , the function selected in <i>parameter 6-01 Live Zero Timeout Function</i> is activated.

6-01 Live Zero Timeout Function	
Option:	Function:
	Select the time-out function. The function set in <i>parameter 6-01 Live Zero Timeout Function</i> is activated if the input signal on terminal 53 or 54 is below 50% of the value in <i>parameter 6-10 Terminal 53 Low Voltage</i> ,

6-01 Live Zero Timeout Function	
Option:	Function:
	<p>6-12 Terminal 53 Low Current, parameter 6-20 Terminal 54 Low Voltage or 6-22 Terminal 54 Low Current for a time period defined in <i>parameter 6-00 Live Zero Timeout Time</i>. If several time-outs occur simultaneously, the frequency converter prioritises the time-out functions as follows</p> <ol style="list-style-type: none"> 1. <i>Parameter 6-01 Live Zero Timeout Function</i> 2. <i>8-04 Control Timeout Function</i> <p>The output frequency of the frequency converter can be:</p> <ul style="list-style-type: none"> • [1] frozen at the present value • [2] overruled to stop • [3] overruled to jog speed • [4] overruled to max. speed • [5] overruled to stop with subsequent trip
[0] *	Off
[1]	Freeze output
[2]	Stop
[3]	Jogging
[4]	Max. speed
[5]	Stop and trip

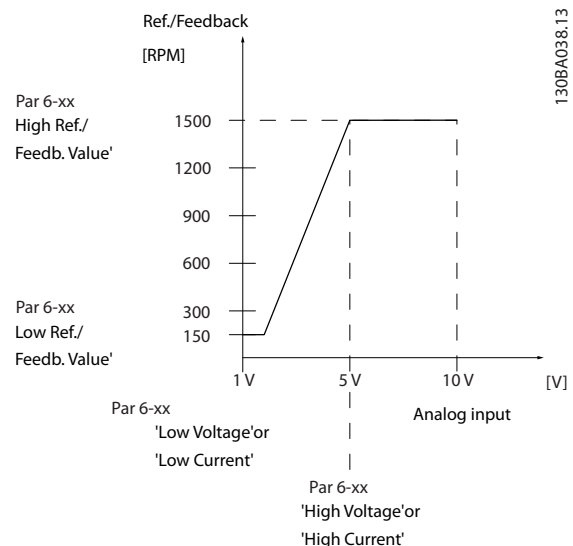

Illustration 6.18 Live Zero Conditions

6-10 Terminal 53 Low Voltage		
Range:	Function:	
0.07 V* [0 - par. 6-11 V]	Enter the low-voltage value. This analog input scaling value should correspond to the low reference/feedback value set in <i>parameter 6-14 Terminal 53 Low Ref./Feedb. Value.</i>	

6-11 Terminal 53 High Voltage		
Range:	Function:	
10 V* [par. 6-10 - 10 V]	Enter the high-voltage value. This analog input scaling value should correspond to the high reference/feedback value set in <i>parameter 6-15 Terminal 53 High Ref./Feedb. Value.</i>	

6-14 Terminal 53 Low Ref./Feedb. Value		
Range:	Function:	
0* [-999999.999 - 999999.999]	Enter the analog input scaling value that corresponds to the low voltage/low current set in <i>parameter 6-10 Terminal 53 Low Voltage</i> and <i>6-12 Terminal 53 Low Current.</i>	

6-15 Terminal 53 High Ref./Feedb. Value		
Range:	Function:	
Size related* [-999999.999 - 999999.999]	Enter the analog input scaling value that corresponds to the high voltage/high current value set in <i>parameter 6-11 Terminal 53 High Voltage</i> and <i>6-13 Terminal 53 High Current.</i>	

6-20 Terminal 54 Low Voltage		
Range:	Function:	
0.07 V* [0 - par. 6-21 V]	Enter the low-voltage value. This analog input scaling value should correspond to the low reference/feedback value, set in <i>parameter 6-24 Terminal 54 Low Ref./Feedb. Value.</i>	

6-21 Terminal 54 High Voltage		
Range:	Function:	
10 V* [par. 6-20 - 10 V]	Enter the high-voltage value. This analog input scaling value should correspond to the high reference/feedback value set in <i>parameter 6-25 Terminal 54 High Ref./Feedb. Value.</i>	

6-24 Terminal 54 Low Ref./Feedb. Value		
Range:	Function:	
0* [-999999.999 - 999999.999]	Enter the analog input scaling value that corresponds to the low voltage/low current value set in	

6-24 Terminal 54 Low Ref./Feedb. Value		
Range:	Function:	
	<i>parameter 6-20 Terminal 54 Low Voltage</i> and <i>6-22 Terminal 54 Low Current.</i>	

6-25 Terminal 54 High Ref./Feedb. Value		
Range:	Function:	
100* [-999999.999 - 999999.999]	Enter the analog input scaling value that corresponds to the high voltage/high current value set in <i>parameter 6-21 Terminal 54 High Voltage</i> and <i>6-23 Terminal 54 High Current.</i>	

6-50 Terminal 42 Output		
Option:	Function:	
	Select the function of Terminal 42 as an analog current output. A motor current of 20 mA corresponds to I_{max} .	
[0]	No operation	
[100] *	Output freq. 0-100	0-100 Hz, (0-20 mA)
[101]	Reference Min-Max	Minimum reference - Maximum reference, (0-20 mA)
[102]	Feedback +200%	-200% to +200% of 20-14 <i>Maximum Reference/Feedb.</i> , (0-20 mA)
[103]	Motor cur. 0-Imax	0 - Inverter Max. Current (<i>16-37 Inv. Max. Current</i>), (0-20 mA)
[104]	Torque 0-Tlim	0 - Torque limit (<i>4-16 Torque Limit Motor Mode</i>), (0-20 mA)
[105]	Torque 0-Tnom	0 - Motor rated torque, (0-20 mA)
[106]	Power 0-Pnom	0 - Motor rated power, (0-20 mA)
[107]	Speed 0-HighLim	0 - Speed High Limit (<i>parameter 4-13 Motor Speed High Limit [RPM]</i> and <i>4-14 Motor Speed High Limit [Hz]</i>), (0-20 mA)
[108]	Torque +-160%	
[109]	Out frq 0-Fmax	
[113]	Ext. Closed Loop 1	0-100%, (0-20 mA)
[114]	Ext. Closed Loop 2	0-100%, (0-20 mA)
[115]	Ext. Closed Loop 3	0-100%, (0-20 mA)
[116]	Cascade Reference	
[130]	Out frq 0-100 4-20mA	0-100 Hz
[131]	Reference 4-20mA	Minimum Reference - Maximum Reference
[132]	Feedback 4-20mA	-200% to +200% of 20-14 <i>Maximum Reference/Feedb.</i>
[133]	Motor cur. 4-20mA	0 - Inverter Max. Current (<i>16-37 Inv. Max. Current</i>)

6-50 Terminal 42 Output		
Option:	Function:	
[134]	Torq.0-lim 4-20 mA	0 - Torque limit (4-16 Torque Limit Motor Mode)
[135]	Torq.0-nom 4-20mA	0 - Motor rated torque
[136]	Power 4-20mA	0 - Motor rated power
[137]	Speed 4-20mA	0 - Speed High Limit (4-13 and 4-14)
[138]	Torque 4-20mA	
[139]	Bus ctrl.	0-100%, (0-20 mA)
[140]	Bus ctrl. 4-20 mA	0-100%
[141]	Bus ctrl t.o.	0-100%, (0-20 mA)
[142]	Bus ctrl t.o. 4-20mA	0-100%
[143]	Ext. CL 1 4-20mA	0-100%
[144]	Ext. CL 2 4-20mA	0-100%
[145]	Ext. CL 3 4-20mA	0-100%
[146]	Cascade Ref. 4-20mA	
[147]	Main act val 0-20mA	
[148]	Main act val 4-20mA	
[150]	Out frq 0-Fmax 4-20mA	
[254]	DC Link 0-20mA	
[255]	DC Link 4-20mA	

NOTICE

Values for setting the minimum reference are found in open loop *parameter 3-02 Minimum Reference* and for closed loop *20-13 Minimum Reference/Feedb.* - values for maximum reference for open loop is found in *3-03 Maximum Reference* and for closed loop *20-14 Maximum Reference/Feedb.*

6-51 Terminal 42 Output Min Scale		
Range:	Function:	
0 %* [0 - 200 %]	Scale for the minimum output (0 mA or 4 mA) of the analog signal at terminal 42. Set the value to be the percentage of the full range of the variable selected in <i>parameter 6-50 Terminal 42 Output.</i>	

6-52 Terminal 42 Output Max Scale		
Range:	Function:	
100 %* [0 - 200 %]	Scale for the maximum output (20 mA) of the analog signal at terminal 42. Set the value to be the percentage of the full range of the variable selected in <i>parameter 6-50 Terminal 42 Output.</i>	

6-52 Terminal 42 Output Max Scale		
Range:	Function:	
	<p>Illustration 6.19 Output Current vs Reference Variable</p> <p>It is possible to get a value lower than 20 mA at full scale by programming values >100% by using a formula as follows:</p>	

$$20 \text{ mA} / \text{desired maximum current} \times 100\%$$

i. e. 10 mA: $\frac{20 \text{ mA}}{10 \text{ mA}} \times 100\% = 200\%$

Example 1:

Variable=OUTPUT FREQUENCY, range=0-100 Hz
 Range needed for output=0-50 Hz
 Output signal 0 mA or 4 mA is needed at 0 Hz (0% of range) - set *parameter 6-51 Terminal 42 Output Min Scale* to 0%
 Output signal 20 mA is needed at 50 Hz (50% of range) - set *parameter 6-52 Terminal 42 Output Max Scale* to 50%

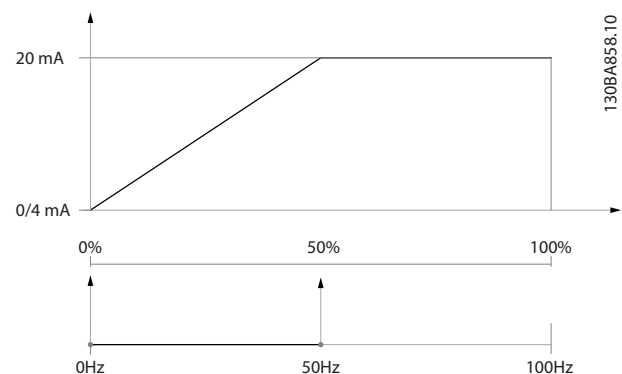

Illustration 6.20 Example 1

Example 2:

Variable=FEEDBACK, range=-200% to +200%
 Range needed for output=0-100%
 Output signal 0 mA or 4 mA is needed at 0% (50% of range) - set *parameter 6-51 Terminal 42 Output Min Scale* to 50%
 Output signal 20 mA is needed at 100% (75% of range) - set *parameter 6-52 Terminal 42 Output Max Scale* to 75%

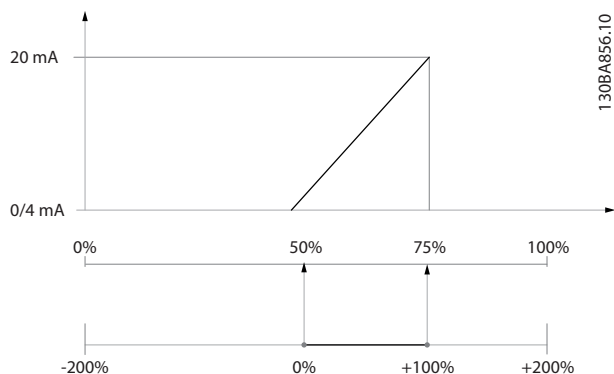

Illustration 6.21 Example 2

6

Example 3:

Variable value=REFERENCE, range=Minimum ref - maximum ref.

Range needed for output=Minimum ref (0%) - Maximum ref (100%), 0-10 mA

Output signal 0 mA or 4 mA is needed at minimum ref - set parameter 6-51 Terminal 42 Output Min Scale to 0%

Output signal 10 mA is needed at maximum ref (100% of range) - set parameter 6-52 Terminal 42 Output Max Scale to 200%

(20 mA/10 mA x 100%=200%).

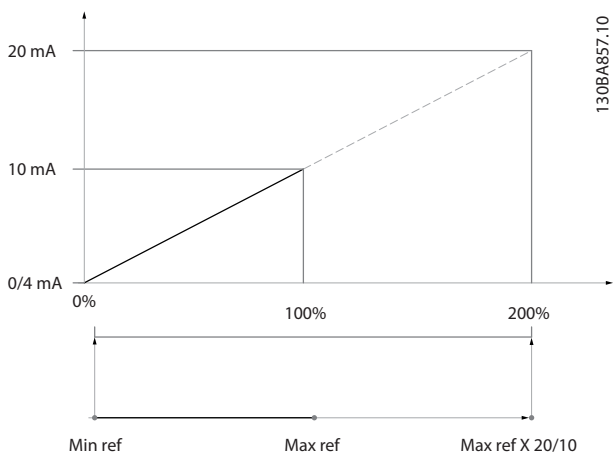

Illustration 6.22 Example 3

This parameter group is used for configuring the closed loop PID Controller, that controls the output frequency of the frequency converter.

20-12 Reference/Feedback Unit		
Option:	Function:	
[0]	-	
[1]	%	
[5]	PPM	
[10]	1/min	
[11]	RPM	
[12]	Pulse/s	
[20]	l/s	

20-12 Reference/Feedback Unit		
Option:	Function:	
[21]	l/min	
[22]	l/h	
[23]	m ³ /s	
[24]	m ³ /min	
[25]	m ³ /h	
[30]	kg/s	
[31]	kg/min	
[32]	kg/h	
[33]	t/min	
[34]	t/h	
[40]	m/s	
[41]	m/min	
[45]	m	
[60]	°C	
[70]	mbar	
[71]	bar	
[72]	Pa	
[73]	kPa	
[74]	m WG	
[75]	mm Hg	
[80]	kW	
[120]	GPM	
[121]	gal/s	
[122]	gal/min	
[123]	gal/h	
[124]	CFM	
[125]	ft ³ /s	
[126]	ft ³ /min	
[127]	ft ³ /h	
[130]	lb/s	
[131]	lb/min	
[132]	lb/h	
[140]	ft/s	
[141]	ft/min	
[145]	ft	
[160]	°F	
[170]	psi	
[171]	lb/in ²	
[172]	in WG	
[173]	ft WG	
[174]	in Hg	
[180]	HP	This parameter determines the unit that is used for the setpoint reference and feedback that the PID controller uses for controlling the output frequency of the frequency converter.

20-21 Setpoint 1		
Range:		Function:
0 ProcessCtrlUnit*	[-999999.999 - 999999.999 ProcessCtrlUnit]	Setpoint 1 is used in closed loop mode to enter a setpoint reference that is used by the frequency converter's PID controller. See the description of <i>20-20 Feedback Function</i> . NOTICE The setpoint reference entered here is added to any other references that are enabled (see parameter group 3-1* <i>References</i>).

20-81 PID Normal/ Inverse Control		
Option:		Function:
[0] *	Normal	The frequency converter's output frequency decreases when the feedback is greater than the setpoint reference. This is common for pressure-controlled supply fan and pump applications.
[1]	Inverse	The frequency converter's output frequency increases when the feedback is greater than the setpoint reference.

20-82 PID Start Speed [RPM]		
Range:		Function:
Size related*	[0 - par. 4-13 RPM]	When the frequency converter is first started, it initially ramps-up to this output speed in open loop mode, following the active ramp up time. When the output speed programmed is reached, the frequency converter automatically switches to closed loop mode and the PID controller begins to function. This is useful in applications that require quick acceleration to a minimum speed at start-up. NOTICE This parameter is only visible if <i>0-02 Motor Speed Unit</i> is set to [0] RPM.

20-93 PID Proportional Gain		
Range:		Function:
2*	[0 - 10]	The proportional gain indicates the number of times the error between the set point and the feedback signal is to be applied.

If (Error x Gain) jumps with a value equal to what is set in *20-14 Maximum Reference/Feedb.*, the PID controller tries to change the output speed equal to what is set in *parameter 4-13 Motor Speed High Limit [RPM]/4-14 Motor Speed High Limit [Hz]*. However, the output speed is limited by this setting.

The proportional band (error causing output to change from 0-100%) can be calculated with the formula

$$\left(\frac{1}{\text{Proportional Gain}}\right) \times (\text{Max Reference})$$

NOTICE

Always set the desired value for *20-14 Maximum Reference/Feedb.* before setting the values for the PID controller in parameter group *20-9* PID Controller*.

20-94 PID Integral Time		
Range:		Function:
8 s*	[0.01 - 10000 s]	The integrator accumulates a contribution to the output from the PID controller as long as there is a deviation between the reference/setpoint and feedback signals. The contribution is proportional to the size of the deviation. This ensures that the deviation (error) approaches zero. Quick response on any deviation is obtained when the integral time is set to a low value. Setting it too low, however, may cause the control to become unstable. The value set is the time needed for the integrator to add the same contribution as the proportional for a certain deviation. If the value is set to 10,000, the controller acts as a pure proportional controller with a P-band based on the value set in <i>parameter 20-93 PID Proportional Gain</i> . When no deviation is present, the output from the proportional controller is 0.

6.2.7 22-0* Miscellaneous

This group contains parameters used for monitoring water/ wastewater applications.

6

22-20 Low Power Auto Set-up		
Start of auto set-up of power data for no-flow power tuning.		
Option:	Function:	
[0] *	Off	
[1]	Enabled	An auto set-up sequence is activated, automatically setting speed to approx. 50 and 85% of rated motor speed (<i>parameter 4-13 Motor Speed High Limit [RPM], 4-14 Motor Speed High Limit [Hz]</i>). At those 2 speeds, the power consumption is automatically measured and stored. Before enabling auto set-up: <ol style="list-style-type: none"> Close valve(s) to create a no-flow condition The frequency converter must be set for open loop (<i>parameter 1-00 Configuration Mode</i>). Note that it is important also to set <i>1-03 Torque Characteristics</i>.

NOTICE

Auto set-up must be done when the system has reached normal operating temperature!

NOTICE

It is important that the *parameter 4-13 Motor Speed High Limit [RPM]* or *4-14 Motor Speed High Limit [Hz]* is set to the max. operational speed of the motor!
It is important to do the auto set-up before configuring the integrated PI controller as settings are reset when changing from closed to open loop in *parameter 1-00 Configuration Mode*.

NOTICE

Carry out the tuning with the same settings in *1-03 Torque Characteristics*, as for operation after the tuning.

22-21 Low Power Detection		
Option:	Function:	
[0] *	Disabled	
[1]	Enabled	The low-power detection commissioning must be carried out to set the parameters in parameter group 22-3* <i>No-Flow Power Tuning</i> for proper operation.

22-22 Low Speed Detection		
Option:	Function:	
[0] *	Disabled	
[1]	Enabled	Detects when the motor operates with a speed as set in <i>parameter 4-11 Motor Speed Low Limit [RPM]</i> or <i>4-12 Motor Speed Low Limit [Hz]</i> .

22-23 No-Flow Function		
Common actions for low-power detection and low-speed detection (Individual selections not possible).		
Option:	Function:	
[0] *	Off	
[1]	Sleep Mode	The frequency converter enters sleep mode and stops when a no-flow condition is detected. See parameter group 22-4* <i>Sleep Mode</i> for programming options for sleep mode.
[2]	Warning	The frequency converter continues to run, but activates a no-flow warning [W92]. A digital output or a serial communication bus can communicate a warning to other equipment.
[3]	Trip	The frequency converter stops running and activates a no-flow alarm [A 92]. A frequency converter digital output or a serial communication bus can communicate an alarm to other equipment.
[4]	Stop and Trip	

NOTICE

Do not set *14-20 Reset Mode*, to *[13] Infinite auto reset*, when *parameter 22-23 No-Flow Function* is set to *[3] Alarm*. Doing so, causes the frequency converter to continuously cycle between running and stopping when a no-flow condition is detected.

NOTICE

Disable the bypass's automatic bypass function

- if the frequency converter is equipped with a constant speed bypass with an automatic bypass function starting the bypass if the frequency converter experiences a persistent alarm condition, and
- if *[3] Alarm* is selected as the no-flow function.

22-24 No-Flow Delay		
Range:	Function:	
10 s*	[1 - 600 s]	Set the time that low power/low speed must stay detected to activate signal for actions. If detection disappears before the timer runs out, the timer is reset.

22-26 Dry Pump Function		
Select desired action for dry pump operation.		
Option:	Function:	
[0] *	Off	
[1]	Warning	The frequency converter continues to run, but activates a dry pump warning [W93]. A frequency converter digital output or a serial communication bus can communicate a warning to other equipment.
[2]	Trip	The frequency converter stops running and activates a dry pump alarm [A93]. A frequency converter digital output or a serial communication bus can communicate an alarm to other equipment.
[3]	Manual Reset Trip	The frequency converter stops running and activates a dry pump alarm [A93]. A frequency converter digital output or a serial communication bus can communicate an alarm to other equipment.
[4]	Stop and Trip	

NOTICE

Low Power Detection must be enabled (parameter 22-21 Low Power Detection) and commissioned (using either parameter group 22-3* No-flow Power Tuning No Flow Power Tuning, or parameter 22-20 Low Power Auto Set-up) to use dry-pump detection.

NOTICE

Do not set 14-20 Reset Mode, to [13] Infinite auto reset, when parameter 22-26 Dry Pump Function is set to [2] Alarm. Doing so causes the frequency converter to continuously cycle between running and stopping when a dry pump condition is detected.

NOTICE

If the frequency converter is equipped with a constant speed bypass with an automatic bypass function that starts the bypass if the frequency converter experiences a persistent alarm condition, be sure to disable the bypass's automatic bypass function, if [2] Alarm or [3] Man. Reset Alarm is selected as the dry-pump function.

22-27 Dry Pump Delay		
Range:	Function:	
10 s*	[0 - 600 s]	Defines for how long the dry-pump condition must be active before activating warning or alarm. The frequency converter waits for the no-flow delay time (parameter 22-24 No-Flow Delay) to

22-27 Dry Pump Delay		
Range:	Function:	
		expire before the timer for the dry pump delay starts.

22-30 No-Flow Power		
Range:	Function:	
0 kW*	[0 - 0 kW]	Readout of calculated no-flow power at actual speed. If power drops to the display value, the frequency converter considers the condition as a no-flow situation.

22-31 Power Correction Factor		
Range:	Function:	
100 %*	[1 - 400 %]	Make corrections to the calculated power at <i>parameter 22-30 No-Flow Power</i> . If no flow is detected, when it should not be detected, decrease the setting. However, if no flow is not detected, when it should be detected, increase the setting to above 100%.

22-32 Low Speed [RPM]		
Range:	Function:	
Size related*	[0 - par. 22-36 RPM]	To be used if 0-02 Motor Speed Unit has been set for RPM (parameter not visible if Hz selected). Set used speed for the 50% level. This function is used for storing values needed to tune no-flow detection.

22-33 Low Speed [Hz]		
Range:	Function:	
Size related*	[0 - par. 22-37 Hz]	To be used if 0-02 Motor Speed Unit has been set for Hz (parameter not visible if RPM selected). Set used speed for the 50% level. The function is used for storing values needed to tune no-flow detection.

22-34 Low Speed Power [kW]		
Range:	Function:	
Size related*	[0 - 5.50 kW]	To be used if 0-03 Regional Settings has been set for International (parameter not visible if North America selected). Set power consumption at 50% speed level. This function is used for storing values needed to tune no-flow detection.

22-35 Low Speed Power [HP]		
Range:		Function:
Size related*	[0 - 7.50 hp]	To be used if <i>0-03 Regional Settings</i> has been set for North America (parameter not visible if International selected). Set power consumption at 50% speed level. This function is used for storing values needed to tune no-flow detection.

22-36 High Speed [RPM]		
Range:		Function:
Size related*	[0 - par. 4-13 RPM]	To be used if <i>0-02 Motor Speed Unit</i> has been set for RPM (parameter not visible if Hz selected). Set used speed for the 85% level. The function is used for storing values needed to tune no-flow detection.

22-37 High Speed [Hz]		
Range:		Function:
Size related*	[0 - par. 4-14 Hz]	To be used if <i>0-02 Motor Speed Unit</i> has been set for Hz (parameter not visible if RPM selected). Set used speed for the 85% level. The function is used for storing values needed to tune no-flow detection.

22-38 High Speed Power [kW]		
Range:		Function:
Size related*	[0 - 5.50 kW]	To be used if <i>0-03 Regional Settings</i> has been set for International (parameter not visible if North America selected). Set power consumption at 85% speed level. This function is used for storing values needed to tune no-flow detection.

22-39 High Speed Power [HP]		
Range:		Function:
Size related*	[0 - 7.50 hp]	To be used if <i>0-03 Regional Settings</i> has been set for North America (parameter not visible if International selected). Set power consumption at 85% speed level. This function is used for storing values needed to tune no-flow detection.

22-40 Minimum Run Time		
Range:		Function:
60 s*	[0 - 600 s]	Set the desired minimum running time for the motor after a start command (digital input or bus) before entering sleep mode.

22-41 Minimum Sleep Time		
Range:		Function:
30 s*	[0 - 600 s]	Set the desired minimum time for staying in sleep mode. This setting overrides any wake-up conditions.

22-42 Wake-up Speed [RPM]		
Range:		Function:
Size related*	[0 - par. 4-13 RPM]	To be used if <i>0-02 Motor Speed Unit</i> has been set for RPM (parameter not visible if Hz selected). Only to be used if <i>parameter 1-00 Configuration Mode</i> is set for open loop and an external controller applies speed reference. Set the reference speed at which the sleep mode should be cancelled.

22-43 Wake-up Speed [Hz]		
Range:		Function:
Size related*	[0 - par. 4-14 Hz]	To be used if <i>0-02 Motor Speed Unit</i> , has been set for Hz (parameter not visible if RPM selected). Only to be used if <i>parameter 1-00 Configuration Mode</i> , is set for <i>[0] Open Loop</i> and speed reference is applied by an external controller controlling the pressure. Set the reference speed at which the sleep mode should be cancelled.

22-44 Wake-up Ref./FB Difference		
Range:		Function:
10 %*	[0 - 100 %]	Only to be used if <i>parameter 1-00 Configuration Mode</i> , is set for <i>[3] Closed Loop</i> and the integrated PI controller is used for controlling the pressure. Set the pressure drop allowed in percentage of set point for the pressure (P_{set}) before cancelling the sleep mode. NOTICE If used in applications where the integrated PI controller is set for inverse control in <i>20-71 PID Performance</i> , the value set in <i>22-44 Wake-up Ref./FB Difference</i> is automatically added.

22-45 Setpoint Boost		
Range:	Function:	
0 %* - 100 %]	[-100 - 100 %]	Only to be used if <i>parameter 1-00 Configuration Mode</i> , is set for [3] <i>Closed Loop</i> and the integrated PI controller is used. In systems with e.g. constant pressure control, it is advantageous to increase the system pressure before the motor is stopped. This extends the time in which the motor is stopped and helps to avoid frequent start/stop. Set the desired overpressure/temperature in percentage of setpoint for the pressure (P_{set})/temperature before entering the sleep mode. If setting for 5%, the boost pressure is $P_{set} * 1.05$. The negative values can be used for e.g. cooling tower control where a negative change is needed.

22-46 Maximum Boost Time		
Range:	Function:	
60 s*	[0 - 600 s]	Only to be used if <i>parameter 1-00 Configuration Mode</i> is set for closed loop and the integrated PI controller is used for controlling the pressure. Set the maximum time for which boost mode is allowed. If the set time is exceeded, sleep mode is entered, not waiting for the set boost pressure to be reached.

22-50 End of Curve Function		
Option:	Function:	
[0] * Off	End-of-curve monitoring not active.	
[1]	Warning	The frequency converter continues to run, but activates an end-of-curve warning [W94]. A frequency converter digital output or a serial communication bus can communicate a warning to other equipment.
[2]	Trip	The frequency converter stops running and activates an end-of-curve alarm [A 94]. A frequency converter digital output or a serial communication bus can communicate an alarm to other equipment.
[3]	Manual Reset Trip	The frequency converter stops running and activates an end-of-curve alarm [A 94]. A frequency converter digital output or a serial communication bus can communicate an alarm to other equipment.
[4]	Stop and Trip	

NOTICE

Automatic restart resets the alarm and restarts the system.

NOTICE

Do not set 14-20 *Reset Mode*, to [13] *Infinite auto reset*, when *parameter 22-50 End of Curve Function* is set to [2] *Alarm*. Doing so causes the frequency converter to continuously cycle between running and stopping when an end-of-curve condition is detected.

NOTICE

If the frequency converter is equipped with a constant speed bypass with an automatic bypass function that starts the bypass if the frequency converter experiences a persistent alarm condition, be sure to disable the bypass's automatic bypass function, if [2] *Alarm* or [3] *Man. Reset Alarm* is selected as the end-of-curve function.

22-51 End of Curve Delay		
Range:	Function:	
10 s*	[0 - 600 s]	When an end-of-curve condition is detected, a timer is activated. When the time set in this parameter expires, and the end-of-curve condition has been steady in the entire period, the function set in <i>parameter 22-50 End of Curve Function</i> is activated. If the condition disappears before the timer expires, the timer is reset.

22-80 Flow Compensation		
Option:	Function:	
[0] * Disabled	Setpoint compensation not active.	
[1]	Enabled	Setpoint compensation is active. Enabling this parameter allows the flow-compensated setpoint operation.

22-81 Square-linear Curve Approximation		
Range:	Function:	
100 %*	[0 - 100 %]	Example 1: Adjustment of this parameter allows the shape of the control curve to be adjusted. 0 = Linear 100% = Ideal shape (theoretical).

NOTICE

Not visible when running in cascade.

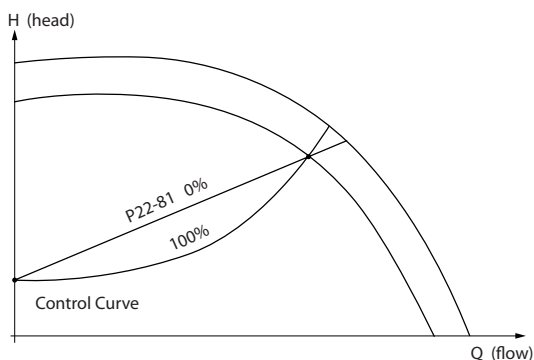

Illustration 6.23 Square-linear Curve Approximation

130BA388.11

6

22-82 Work Point Calculation

Option: Function:

Example 1

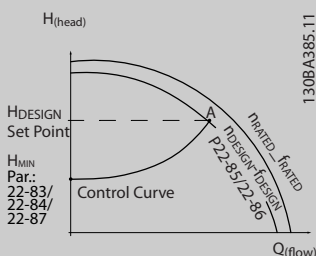

Illustration 6.24 Speed at System Design Working Point is Known

From the data sheet showing characteristics for the specific equipment at different speeds, simply reading across from the H_{DESIGN} point and the Q_{DESIGN} point allows finding point A, which is the system design working point. The pump characteristics at this point should be identified and the associated speed programmed. Closing the valves and adjusting the speed until H_{MIN} has been achieved allows the speed at the no-flow point to be identified.

Adjustment of parameter 22-81 Square-linear Curve Approximation then allows the shape of the control curve to be adjusted infinitely.

Example 2:

Speed at system design working point is not known: Where the speed at system design working point is unknown, another reference point on the control curve needs to be determined by means of the data sheet. By looking at the curve for the rated speed and plotting the design pressure (H_{DESIGN} , Point C) the flow at that pressure, Q_{RATED} , can be determined. Similarly, by plotting the design flow (Q_{DESIGN} , Point D) the pressure H_{DESIGN} at that flow can be determined. Knowing these 2 points on the pump curve, along

22-82 Work Point Calculation

Option: Function:

with H_{MIN} as described above, allows the frequency converter to calculate the reference point B and thus to plot the control curve which also includes the system design working point A.

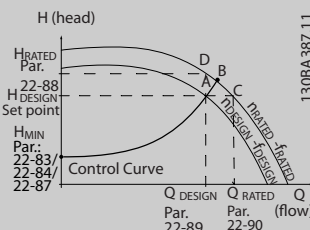

Illustration 6.25 Speed at System Design Working Point is not Known

[0]	Disabled	Work point calculation not active. To be used if speed at design point is known.
[1]	Enabled	Work point calculation is active. Enabling this parameter allows the calculation of the unknown system design working point at 50/60 Hz speed, from the input data set in parameter 22-83 Speed at No-Flow [RPM], parameter 22-84 Speed at No-Flow [Hz], parameter 22-87 Pressure at No-Flow Speed, parameter 22-88 Pressure at Rated Speed, 22-89 Flow at Design Point and parameter 22-90 Flow at Rated Speed.

22-84 Speed at No-Flow [Hz]

Range: Function:

Size related*	[0 - par. 22-86 Hz]	Resolution 0.033 Hz. Enter the motor speed in Hz at which flow has effectively stopped and minimum pressure H_{MIN} is achieved. Alternatively, the speed in RPM can be entered in parameter 22-83 Speed at No-Flow [RPM]. If it has been decided to use Hz in 0-02 Motor Speed Unit, parameter 22-86 Speed at Design Point [Hz] should also be used. Closing the valves and reducing the speed until minimum pressure H_{MIN} is achieved determines this value.
---------------	----------------------	--

22-85 Speed at Design Point [RPM]		
Range:	Function:	
Size related*	[0 - 60000 RPM]	Resolution 1 RPM. Only visible when <i>parameter 22-82 Work Point Calculation</i> is set to [0] <i>Disabled</i> . Enter the motor speed in RPM at which the system design working point is achieved. Alternatively, the speed in Hz can be entered in <i>parameter 22-86 Speed at Design Point [Hz]</i> . If it has been decided to use RPM in <i>0-02 Motor Speed Unit</i> then <i>parameter 22-83 Speed at No-Flow [RPM]</i> should also be used.

22-86 Speed at Design Point [Hz]		
Range:	Function:	
Size related*	[0.0 - par. 4-19 Hz]	Resolution 0.033 Hz. Only visible when <i>parameter 22-82 Work Point Calculation</i> is set to [0] <i>Disabled</i> . Enter the motor speed in Hz at which the system design working point is achieved. Alternatively, the speed in RPM can be entered in <i>parameter 22-85 Speed at Design Point [RPM]</i> . If it has been decided to use Hz in <i>0-02 Motor Speed Unit</i> , <i>parameter 22-83 Speed at No-Flow [RPM]</i> should also be used.

22-87 Pressure at No-Flow Speed		
Range:	Function:	
0*	[0 - par. 22-88]	Enter the pressure H_{MIN} corresponding to speed at no-flow in reference/feedback units.

Also see *parameter 22-82 Work Point Calculation* point D.

22-88 Pressure at Rated Speed		
Range:	Function:	
999999.999*	[par. 22-87 - 999999.999]	Enter the value corresponding to the pressure at rated speed, in reference/feedback units. This value can be defined using the pump datasheet.

22-83 Speed at No-Flow [RPM]		
Range:	Function:	
Size related*	[0 - par. 22-85 RPM]	Resolution 1 RPM. The speed of the motor at which flow is zero and minimum pressure H_{MIN} is achieved should be entered here in RPM. Alternatively, the speed in Hz can be entered in <i>parameter 22-84 Speed at No-Flow [Hz]</i> . If it has been decided to use RPM in <i>0-02 Motor Speed Unit</i> then <i>parameter 22-85 Speed at Design Point [RPM]</i> should also be used.

22-83 Speed at No-Flow [RPM]		
Range:	Function:	
		Closing the valves and reducing the speed until minimum pressure H_{MIN} is achieved determines this value.

Also see *parameter 22-82 Work Point Calculation* point C.

22-90 Flow at Rated Speed		
Range:	Function:	
0*	[0 - 999999.999]	Enter the value corresponding to flow at rated speed. This value can be defined using the pump datasheet.

6.2.8 23-0* Timed Actions

Use *Timed Actions* for actions needing to be performed on a daily or weekly basis, e.g. different references for working hours/non-working hours. Up to 10 timed actions can be programmed in the frequency converter. The timed action number is selected from the list when entering parameter group *23-0* Timed Actions* from the LCP.

Parameter 23-00 ON Time – *parameter 23-04 Occurrence* then refer to the selected timed action number. Each timed action is divided into an ON time and an OFF time, in which 2 different actions may be performed.

Display lines 2 and 3 in the LCP show the status for timed actions mode (*0-23 Display Line 2 Large* and *0-24 Display Line 3 Large*, setting [1643] *Timed Actions Status*).

NOTICE

A change in mode via the digital inputs can only take place if *23-08 Timed Actions Mode* is set for [0] *Times Actions Auto*.

If commands are applied simultaneously to the digital inputs for Constant OFF and Constant ON, the timed actions mode changes to timed actions auto and the 2 commands are disregarded.

If *0-70 Date and Time* is not set or the frequency converter is set to HAND or OFF mode (e.g. via the LCP), the timed actions mode is changed to *Timed Actions Disabled*.

The timed actions have a higher priority than the same actions/commands activated by the digital inputs or the Smart Logic Controller.

The actions programmed in timed actions are merged with corresponding actions from digital inputs, control word via bus and Smart Logic Controller, according to merge rules set up in parameter group *8-5* Digital/Bus*.

NOTICE

The clock (parameter group 0-7* *Clock Settings*) must be correctly programmed for timed actions to function correctly.

NOTICE

When mounting an analog I/O MCB 109 option card, a battery back-up of the date and time is included.

NOTICE

The PC-based configuration tool MCT 10 Set-up Software comprises a special guide for easy programming of timed actions.

6

23-00 ON Time		
Array [10]		
Range:	Function:	
Size related*	[0 - 0]	Sets the ON time for the timed action.
<p>NOTICE</p> <p>The frequency converter has no back-up of the clock function and the set date/time resets to default (2000-01-01 00:00) after a power down unless a Real Time Clock module with back-up is installed. In 0-79 <i>Clock Fault</i> it is possible to program for a warning in case clock has not been set properly, e.g. after a power-down.</p>		

23-01 ON Action		
Arra [10]		
Option:	Function:	
		Select the action during ON Time. See 13-52 <i>SL Controller Action</i> for descriptions of the options.
[0] *	Disabled	
[1]	No action	
[2]	Select set-up 1	
[3]	Select set-up 2	
[4]	Select set-up 3	
[5]	Select set-up 4	
[10]	Select preset ref 0	
[11]	Select preset ref 1	
[12]	Select preset ref 2	
[13]	Select preset ref 3	
[14]	Select preset ref 4	
[15]	Select preset ref 5	
[16]	Select preset ref 6	
[17]	Select preset ref 7	
[18]	Select ramp 1	

23-01 ON Action		
Arra [10]		
Option:	Function:	
[19]	Select ramp 2	
[22]	Run	
[23]	Run reverse	
[24]	Stop	
[26]	DC Brake	
[27]	Coast	
[28]	Freeze output	
[29]	Start timer 0	
[30]	Start timer 1	
[31]	Start timer 2	
[32]	Set digital out A low	
[33]	Set digital out B low	
[34]	Set digital out C low	
[35]	Set digital out D low	
[36]	Set digital out E low	
[37]	Set digital out F low	
[38]	Set digital out A high	
[39]	Set digital out B high	
[40]	Set digital out C high	
[41]	Set digital out D high	
[42]	Set digital out E high	
[43]	Set digital out F high	
[60]	Reset Counter A	
[61]	Reset Counter B	
[70]	Start Timer 3	
[71]	Start Timer 4	
[72]	Start Timer 5	
[73]	Start Timer 6	
[74]	Start Timer 7	
[80]	Sleep Mode	
[81]	Derag	

NOTICE

For choices [32] - [43], see also parameter group 5-3* *Digital Outputs and 5-4* Relays*.

23-02 OFF Time		
Array [10]		
Range:	Function:	
Size related*	[0 - 0]	Sets the OFF time for the timed action.
<p>NOTICE</p> <p>The frequency converter has no back-up of the clock function and the set date/time is reset to default (2000-01-01 00:00) after a power down unless a Real Time Clock module with back-up is installed. In 0-79 Clock Fault it is possible to program for a warning in case clock has not been set properly, e.g. after a power down.</p>		

23-03 OFF Action		
Array [10]		
Option:	Function:	
	Select the action during OFF Time. See 13-52 SL Controller Action for descriptions of the options.	
[0] *	Disabled	
[1]	No action	
[2]	Select set-up 1	
[3]	Select set-up 2	
[4]	Select set-up 3	
[5]	Select set-up 4	
[10]	Select preset ref 0	
[11]	Select preset ref 1	
[12]	Select preset ref 2	
[13]	Select preset ref 3	
[14]	Select preset ref 4	
[15]	Select preset ref 5	
[16]	Select preset ref 6	
[17]	Select preset ref 7	
[18]	Select ramp 1	
[19]	Select ramp 2	
[22]	Run	
[23]	Run reverse	
[24]	Stop	
[26]	DC Brake	
[27]	Coast	
[28]	Freeze output	
[29]	Start timer 0	
[30]	Start timer 1	
[31]	Start timer 2	
[32]	Set digital out A low	
[33]	Set digital out B low	
[34]	Set digital out C low	
[35]	Set digital out D low	
[36]	Set digital out E low	

23-03 OFF Action		
Array [10]		
Option:	Function:	
[37]	Set digital out F low	
[38]	Set digital out A high	
[39]	Set digital out B high	
[40]	Set digital out C high	
[41]	Set digital out D high	
[42]	Set digital out E high	
[43]	Set digital out F high	
[60]	Reset Counter A	
[61]	Reset Counter B	
[70]	Start Timer 3	
[71]	Start Timer 4	
[72]	Start Timer 5	
[73]	Start Timer 6	
[74]	Start Timer 7	
[80]	Sleep Mode	
[81]	Derag	

23-04 Occurrence		
Array [10]		
Option:	Function:	
	Select which day(s) the timed action applies to. Specify working/non-working days in 0-81 Working Days, 0-82 Additional Working Days and 0-83 Additional Non-Working Days.	
[0] *	All days	
[1]	Working days	
[2]	Non-working days	
[3]	Monday	
[4]	Tuesday	
[5]	Wednesday	
[6]	Thursday	
[7]	Friday	
[8]	Saturday	
[9]	Sunday	

The group contains parameters used for monitoring water/wastewater applications.

29-00 Pipe Fill Enable		
Option:	Function:	
[0] *	Disabled	Select Enabled to fill pipes at a user specified rate.
[1]	Enabled	Select Enabled to fill pipes at a user specified rate.

29-01 Pipe Fill Speed [RPM]		
Range:	Function:	
Size related*	[par. 4-11 - par. 4-13 RPM]	Set the filling speed for filling horizontal pipe systems. The speed can be selected in Hz or RPM depending on the choices

29-01 Pipe Fill Speed [RPM]		
Range:		Function:
		made in <i>parameter 4-11 Motor Speed Low Limit [RPM]</i> / <i>parameter 4-13 Motor Speed High Limit [RPM]</i> or in <i>4-12 Motor Speed Low Limit [Hz]</i> / <i>4-14 Motor Speed High Limit [Hz]</i> .

29-02 Pipe Fill Speed [Hz]		
Range:		Function:
Size related*	[par. 4-12 - par. 4-14 Hz]	Set the filling speed for filling horizontal pipe systems. The speed can be selected in Hz or RPM depending on the choices made in <i>parameter 4-11 Motor Speed Low Limit [RPM]</i> / <i>parameter 4-13 Motor Speed High Limit [RPM]</i> or in <i>4-12 Motor Speed Low Limit [Hz]</i> / <i>4-14 Motor Speed High Limit [Hz]</i> .

29-03 Pipe Fill Time		
Range:		Function:
0 s*	[0 - 3600 s]	Set the specified time for pipe filling of horizontal pipe systems.

29-04 Pipe Fill Rate		
Range:		Function:
0.001 ProcessCtrlUnit*	[0.001 - 999999.999 ProcessCtrlUnit]	Specifies the filling rate in units/second using the PI controller. Filling rate units are feedback units/second. This function is used for filling-up vertical pipe systems, but is active when the filling-time has expired, no matter what , until the pipe fill-set-point set in <i>29-05 Filled Setpoint</i> is reached.

29-05 Filled Setpoint		
Range:		Function:
0 ProcessCtrlUnit*	[-999999.999 - 999999.999 ProcessCtrlUnit]	Specifies the filled setpoint at which the pipe fill function is disabled and the PID controller takes control. This function can be used both for horizontal and vertical pipe systems.

6.3 Parameter Options

6.3.1 Default Settings

Changes during operation

"TRUE" means that the parameter can be changed while the frequency converter is in operation and "FALSE" means that the frequency converter must be stopped before a change can be made.

4-Set-up

'All set-up': the parameter can be set individually in each of the 4 set-ups, i. e. one single parameter can have 4 different data values.

'1 set-up': data value is the same in all set-ups.

SR

Size related

N/A

No default value available.

Conversion index

This number refers to a conversion figure used when writing or reading by means of a frequency converter.

Conv. index	100	75	74	70	67	6	5	4	3	2	1	0	-1	-2	-3	-4	-5	-6
Conv. factor	1	3600000	3600	60	1/60	100000	10000	1000	1000	100	10	1	0.1	0.01	0.001	0.0001	0.00001	0.000001

Table 6.9

Data type	Description	Type
2	Integer 8	Int8
3	Integer 16	Int16
4	Integer 32	Int32
5	Unsigned 8	UInt8
6	Unsigned 16	UInt16
7	Unsigned 32	UInt32
9	Visible String	VisStr
33	Normalized value 2 bytes	N2
35	Bit sequence of 16 boolean variables	V2
54	Time difference w/o date	TimD

Table 6.10

0-0*	Operation / Display	1-01	Motor Control Principle	1-82	Min Speed for Function at Stop [Hz]	4-**	Limits / Warnings	5-5*	Pulse Input
0-0*	Basic Settings	1-03	Torque Characteristics	1-86	Trip Speed Low [RPM]	4-1*	Motor Limits	5-50	Term. 29 Low Frequency
0-01	Language	1-04	Overload Mode	1-87	Trip Speed Low [Hz]	4-10	Motor Speed Direction	5-51	Term. 29 High Frequency
0-02	Motor Speed Unit	1-06	Clockwise Direction	1-90	Motor Temperature	4-11	Motor Speed Low Limit [RPM]	5-52	Term. 29 Low Ref./Feedb. Value
0-03	Regional Settings	1-1*	Motor Selection	1-91	Motor Thermal Protection	4-12	Motor Speed Low Limit [Hz]	5-53	Term. 29 High Ref./Feedb. Value
0-04	Operating State at Power-up	1-10	Motor Construction	1-91	Motor External Fan	4-13	Motor Speed High Limit [RPM]	5-54	Pulse Filter Time Constant #29
0-05	Local Mode Unit	1-1*	VVC+ PM	1-93	Thermistor Source	4-14	Motor Speed High Limit [Hz]	5-55	Term. 33 Low Frequency
0-1*	Set-up Operations	1-14	Damping Gain	2-**	Brakes	4-16	Torque Limit Motor Mode	5-56	Term. 33 High Frequency
0-10	Active Set-up	1-15	Low Speed Filter Time Const.	2-0*	DC Brake	4-17	Torque Limit Generator Mode	5-57	Term. 33 Low Ref./Feedb. Value
0-11	Programming Set-up	1-16	High Speed Filter Time Const.	2-00	DC Hold/Preheat Current	4-18	Current Limit	5-58	Term. 33 High Ref./Feedb. Value
0-12	This Set-up Linked to	1-17	Voltage filter time const.	2-01	DC Brake Current	4-19	Max Output Frequency	5-59	Pulse Filter Time Constant #33
0-13	Readout: Linked Set-ups	1-2*	Motor Data	2-02	DC Braking Time	4-5*	Adj. Warnings	5-6*	Pulse Output
0-14	Readout: Prog. Set-ups / Channel	1-20	Motor Power [kW]	2-03	DC Brake Cut In Speed [RPM]	4-50	Warning Current Low	5-60	Terminal 27 Pulse Output Variable
0-2*	LCP Display	1-21	Motor Power [HP]	2-04	DC Brake Cut In Speed [Hz]	4-51	Warning Current High	5-62	Pulse Output Max Freq #27
0-20	Display Line 1.1 Small	1-22	Motor Voltage	2-06	Parking Current	4-52	Warning Speed Low	5-63	Terminal 29 Pulse Output Variable
0-21	Display Line 1.2 Small	1-23	Motor Frequency	2-07	Parking Time	4-53	Warning Speed High	5-65	Pulse Output Max Freq #29
0-22	Display Line 1.3 Small	1-24	Motor Current	2-1*	Brake Energy Funct.	4-54	Warning Reference Low	5-66	Terminal X30/6 Pulse Output Variable
0-23	Display Line 2 Large	1-25	Motor Nominal Speed	2-10	Brake Function	4-55	Warning Reference High	5-68	Pulse Output Max Freq #X30/6
0-24	Display Line 3 Large	1-26	Motor Cont. Rated Torque	2-11	Brake Resistor (ohm)	4-56	Warning Feedback Low	5-8*	I/O Options
0-25	My Personal Menu	1-28	Motor Rotation Check	2-12	Brake Power Limit (kW)	4-57	Warning Feedback High	5-80	AHF Cap Reconnect Delay
0-3*	LCP Custom Readout	1-29	Automatic Motor Adaptation (AMA)	2-13	Brake Power Monitoring	4-58	Missing Motor Phase Function	5-9*	Bus Controlled
0-30	Custom Readout Unit	1-3*	Adv. Motor Data	2-15	Brake Check	4-6*	Speed Bypass	5-90	Digital & Relay Bus Control
0-31	Custom Readout Min Value	1-30	Rotor Resistance (Rs)	2-16	AC brake Max. Current	4-60	Bypass Speed From [RPM]	5-93	Pulse Out #27 Bus Control
0-32	Custom Readout Max Value	1-31	Rotor Resistance (Rr)	2-17	Over-voltage Control	4-61	Bypass Speed From [Hz]	5-94	Pulse Out #27 Timeout Preset
0-37	Display Text 1	1-33	Rotor Leakage Reactance (X1)	3-**	Reference / Ramps	4-62	Bypass Speed To [RPM]	5-95	Pulse Out #29 Bus Control
0-38	Display Text 2	1-34	Rotor Leakage Reactance (X2)	3-0*	Reference Limits	4-63	Bypass Speed To [Hz]	5-96	Pulse Out #29 Timeout Preset
0-39	Display Text 3	1-35	Main Reactance (Xh)	3-02	Minimum Reference	4-64	Semi-Auto Bypass Set-up	5-97	Pulse Out #X30/6 Bus Control
0-4*	LCP keypad	1-36	Iron Loss Resistance (Rfe)	3-03	Maximum Reference	5-5*	Digital In/Out	5-98	Pulse Out #X30/6 Timeout Preset
0-40	[Hand on] Key on LCP	1-37	d-axis Inductance (Ld)	3-04	Reference Function	5-0*	Digital I/O mode	6-5*	Analog In/Out
0-41	[Off] Key on LCP	1-39	Motor Poles	3-1*	References	5-00	Digital I/O Mode	6-0*	Analog I/O Mode
0-42	[Auto on] Key on LCP	1-40	Back EMF at 1000 RPM	3-10	Preset Reference	5-01	Terminal 27 Mode	6-00	Live Zero Timeout Time
0-43	[Reset] Key on LCP	1-46	Position Detection Gain	3-11	Jog Speed [Hz]	5-02	Terminal 29 Mode	6-01	Live Zero Timeout Function
0-44	[Off/Reset] Key on LCP	1-5*	Load Indep. Setting	3-13	Reference Site	5-1*	Digital Inputs	6-1*	Analog Input 53
0-45	[Drive Bypass] Key on LCP	1-50	Motor Magnetisation at Zero Speed	3-14	Preset Relative Reference	5-10	Terminal 18 Digital Input	6-10	Terminal 53 Low Voltage
0-5*	Copy/Save	1-51	Min. Speed Normal Magnetising [RPM]	3-15	Reference 1 Source	5-11	Terminal 19 Digital Input	6-11	Terminal 53 High Voltage
0-50	LCP Copy	1-52	Min. Speed Normal Magnetising [Hz]	3-16	Reference 2 Source	5-12	Terminal 29 Digital Input	6-12	Terminal 53 Low Current
0-51	Set-up Copy	1-55	V/f Characteristic - V	3-17	Reference 3 Source	5-13	Terminal 29 Digital Input	6-13	Terminal 53 High Current
0-6*	Password	1-56	V/f Characteristic - f	3-19	Jog Speed [RPM]	5-14	Terminal 32 Digital Input	6-14	Terminal 53 Low Ref./Feedb. Value
0-60	Main Menu Password	1-58	Flying Start Test Pulses Current	3-4*	Ramp 1	5-15	Terminal 33 Digital Input	6-15	Terminal 53 High Ref./Feedb. Value
0-61	Access to Main Menu w/o Password	1-59	Flying Start Test Pulses Frequency	3-41	Ramp 1 Ramp Up Time	5-16	Terminal X30/2 Digital Input	6-16	Terminal 53 Filter Time Constant
0-65	Personal Menu Password	1-6*	Load Depen. Setting	3-42	Ramp 1 Ramp Down Time	5-17	Terminal X30/3 Digital Input	6-17	Terminal 53 Live Zero
0-66	Access to Personal Menu w/o Password	1-60	Low Speed Load Compensation	3-5*	Ramp 2	5-18	Terminal X30/4 Digital Input	6-2*	Analog Input 54
0-67	Bus Password Access	1-61	High Speed Load Compensation	3-51	Ramp 2 Ramp Up Time	5-19	Terminal 37 Digital Input	6-20	Terminal 54 Low Voltage
0-7*	Clock Settings	1-63	Slip Compensation	3-52	Ramp 2 Ramp Down Time	5-20	Terminal X46/1 Digital Input	6-21	Terminal 54 High Voltage
0-70	Date and Time	1-64	Resonance Damping	3-8*	Other Ramps	5-21	Terminal X46/3 Digital Input	6-22	Terminal 54 Low Current
0-71	Date Format	1-65	Resonance Damping Time Constant	3-80	Jog Ramp Time	5-22	Terminal X46/5 Digital Input	6-23	Terminal 54 High Current
0-72	Time Format	1-66	Min. Current at Low Speed	3-81	Quick Stop Ramp Time	5-23	Terminal X46/7 Digital Input	6-24	Terminal 54 Low Ref./Feedb. Value
0-74	DST/Summerime	1-7*	Start Adjustments	3-85	Initial Ramp Time	5-24	Terminal X46/9 Digital Input	6-25	Terminal 54 High Ref./Feedb. Value
0-76	DST/Summerime Start	1-70	PM Start Mode	3-86	Check Valve Ramp Time	5-25	Terminal X46/11 Digital Input	6-26	Terminal 54 Filter Time Constant
0-77	DST/Summerime End	1-71	Start Delay	3-88	Check Valve Ramp End Speed [RPM]	5-3*	Terminal X46/13 Digital Input	6-27	Terminal 54 Live Zero
0-79	Clock Fault	1-72	Start Function	3-9*	Digital Pot.Meter	5-30	Terminal 29 Digital Output	6-30	Terminal X30/11 Low Voltage
0-81	Working Days	1-73	Flying Start	3-90	Step Size	5-31	Terminal 29 Digital Output	6-31	Terminal X30/11 High Voltage
0-82	Additional Working Days	1-77	Compressor Start Max Speed [RPM]	3-91	Ramp Time	5-32	Term X30/6 Digi Out (MCB 101)	6-34	Term. X30/11 Low Ref./Feedb. Value
0-83	Additional Non-Working Days	1-78	Compressor Start Max Speed [Hz]	3-92	Power Restore	5-33	Term X30/7 Digi Out (MCB 101)	6-35	Term. X30/11 High Ref./Feedb. Value
0-89	Date and Time Readout	1-79	Pump Start Max Time to Trip	3-92	Maximum Limit	5-4*	Relays	6-36	Term. X30/11 Filter Time Constant
1-0*	General Settings	1-80	Function at Stop	3-93	Minimum Limit	5-40	Function Relay	6-37	Term. X30/11 Live Zero
1-00	Configuration Mode	1-81	Min Speed for Function at Stop [RPM]	3-95	Ramp Delay	5-42	Off Delay, Relay	6-4*	Analog Input X30/12

6-41	Terminal X30/12 High Voltage	8-53	Start Select	10-0*	Common Settings	12-38	COS Filter	14-2*	Reset Functions
6-44	Term. X30/12 Low Ref./Feedb. Value	8-54	Reversing Select	10-00	CAN Protocol	12-4*	Modbus TCP	14-20	Reset Mode
6-45	Term. X30/12 High Ref./Feedb. Value	8-55	Set-up Select	10-01	Baud Rate Select	12-40	Status Parameter	14-21	Automatic Restart Time
6-46	Term. X30/12 Filter Time Constant	8-56	Preset Reference Select	10-02	MAC ID	12-41	Slave Message Count	14-22	Operation Mode
6-47	Term. X30/12 Live Zero	8-7*	BACnet	10-05	Readout Transmit Error Counter	12-8*	Other Ethernet Services	14-23	Typecode Setting
6-5*	Analog Output 42	8-70	BACnet Device Instance	10-06	Readout Receive Error Counter	12-80	FTP Server	14-25	Trip Delay at Torque Limit
6-50	Terminal 42 Output	8-72	MS/TP Max Masters	10-07	Readout Bus Off Counter	12-81	HTTP Server	14-26	Trip Delay at Inverter Fault
6-51	Terminal 42 Output Min Scale	8-73	MS/TP Max Info Frames	10-1*	DeviceNet	12-82	SMTP Service	14-28	Production Settings
6-52	Terminal 42 Output Max Scale	8-74	"I-Am" Service	10-10	Process Data Type Selection	12-89	Transparent Socket Channel Port	14-29	Service Code
6-53	Terminal 42 Output Bus Control	8-75	Initialisation Password	10-11	Process Data Config Write	12-9*	Advanced Ethernet Services	14-3*	Current Limit Ctrl.
6-54	Terminal 42 Output Timeout Preset	8-8*	FC Port Diagnostics	10-12	Process Data Config Read	12-90	Cable Diagnostic	14-30	Current Lim Ctrl, Proportional Gain
6-55	Terminal 42 Output Filter	8-80	Bus Message Count	10-13	Warning Parameter	12-91	MDI-X	14-31	Current Lim Ctrl, Integration Time
6-6*	Analog Output X30/8	8-81	Bus Error Count	10-14	Net Reference	12-92	IGMP Snooping	14-4*	Energy Optimising
6-60	Terminal X30/8 Output	8-82	Slave Message Rcvd	10-15	Net Control	12-93	Cable Error Length	14-40	VT Level
6-61	Terminal X30/8 Min. Scale	8-83	Slave Error Count	10-2*	COS Filters	12-94	Broadcast Storm Protection	14-41	AEO Minimum Magnetisation
6-62	Terminal X30/8 Max. Scale	8-9*	Bus Jog / Feedback	10-20	COS Filter 1	12-95	Broadcast Storm Filter	14-42	Minimum AEO Frequency
6-63	Terminal X30/8 Output Bus Control	8-90	Bus Jog 1 Speed	10-21	COS Filter 2	12-96	Port Mirroring	14-43	Motor Cosphi
6-64	Terminal X30/8 Output Timeout Preset	8-91	Bus Jog 2 Speed	10-22	COS Filter 3	12-98	Interface Counters	14-5*	Environment
6-7*	Analog Output X45/1	8-94	Bus Feedback 1	10-3*	Parameter Access	12-99	Media Counters	14-50	RFI Filter
6-70	Terminal X45/1 Output	8-95	Bus Feedback 2	10-30	Array Index	13-*	Smart Logic	14-51	DC Link Compensation
6-71	Terminal X45/1 Min. Scale	8-96	Bus Feedback 3	10-31	Store Data Values	13-0*	SLC Settings	14-52	Fan Control
6-72	Terminal X45/1 Max. Scale	9-0*	PROFIDrive	10-32	DeviceNet Revision	13-00	SL Controller Mode	14-53	Fan Monitor
6-73	Terminal X45/1 Bus Control	9-00	Setpoint	10-33	Store Always	13-01	Start Event	14-55	Output Filter
6-74	Terminal X45/1 Output Timeout Preset	9-07	Actual Value	10-34	DeviceNet Product Code	13-02	Reset Event	14-59	Actual Number of Inverter Units
6-8*	Analog Output X45/3	9-15	PCD Write Configuration	10-39	DeviceNet F Parameters	13-03	Set SLC	14-6*	Auto Derate
6-80	Terminal X45/3 Output	9-16	PCD Read Configuration	12-*	Ethernet	13-1*	Comparators	14-60	Function at Over Temperature
6-81	Terminal X45/3 Min. Scale	9-18	Node Address	12-0*	IP Settings	13-10	Comparator Operand	14-61	Function at Inverter Overload
6-82	Terminal X45/3 Max. Scale	9-22	Telegram Selection	12-01	IP Address Assignment	13-11	Comparator Operator	14-62	Inv. Overload Derate Current
6-83	Terminal X45/3 Bus Control	9-23	Parameters for Signals	12-02	IP Address	13-12	Comparator Value	14-8*	Options
6-84	Terminal X45/3 Output Timeout Preset	9-27	Parameter Edit	12-03	Subnet Mask	13-2*	Timers	14-80	Option Supplied by External 24VDC
8-*	Comm. and Options	9-28	Process Control	12-04	Default Gateway	13-20	SL Controller Timer	14-9*	Fault Settings
8-0*	General Settings	9-31	Safe Address	12-05	DHCP Server	13-4*	Logic Rules	14-90	Fault Level
8-01	Control Site	9-44	Fault Message Counter	12-06	Lease Expires	13-40	Logic Rule Boolean 1	15-*	Drive Information
8-02	Control Source	9-45	Fault Code	12-07	Name Servers	13-41	Logic Rule Operator 1	15-0*	Operating Data
8-03	Control Timeout	9-47	Fault Number	12-08	Host Name	13-42	Logic Rule Boolean 2	15-01	Running Hours
8-04	Control Timeout Time	9-52	Fault Situation Counter	12-09	Physical Address	13-43	Logic Rule Operator 2	15-01	Running Hours
8-05	End-of-Timeout Function	9-53	Profibus Warning Word	12-10	Ethernet Link Parameters	13-44	Logic Rule Boolean 3	15-02	kWh Counter
8-06	Reset Control Timeout	9-63	Actual Baud Rate	12-11	Link Status	13-5*	States	15-03	Power Up's
8-07	Diagnosis Trigger	9-64	Device Identification	12-12	Link Duration	13-51	SL Controller Event	15-04	Over Temp's
8-08	Readout Filtering	9-65	Profile Number	12-13	Auto Negotiation	13-52	SL Controller Action	15-05	Over Volt's
8-1*	Control Settings	9-67	Control Word 1	12-14	Link Duplex	13-9*	User Defined Alerts	15-06	Reset kWh Counter
8-10	Control Profile	9-68	Status Word 1	12-20	Control Instance	13-9*	User Defined Readouts	15-07	Reset Running Hours Counter
8-13	Configurable Status Word STW	9-70	Programming Set-up	12-21	Control Data Config Write	13-97	Alert Alarm Word	15-08	Number of Starts
8-14	Configurable Control Word CTW	9-71	Profibus Save Data Values	12-22	Process Data Config Read	13-98	Alert Warning Word	15-1*	Data Log Settings
8-3*	FC Port Settings	9-72	ProfibusDriveReset	12-27	Primary Master	13-99	Alert Status Word	15-11	Logging Source
8-30	Protocol	9-75	DO Identification	12-28	Store Data Values	14-0*	Special Functions	15-11	Logging Interval
8-31	Address	9-80	Defined Parameters (1)	12-29	Store Always	14-0*	Inverter Switching	15-12	Trigger Event
8-32	Baud Rate	9-81	Defined Parameters (2)	12-30	Warning Parameter	14-01	Switching Pattern	15-13	Logging Mode
8-33	Parity / Stop Bits	9-82	Defined Parameters (3)	12-31	Net Reference	14-01	Switching Frequency	15-14	Samples Before Trigger
8-35	Minimum Response Delay	9-83	Defined Parameters (4)	12-32	Net Control	14-03	Overmodulation	15-21	Historic Log: Event
8-36	Max Response Delay	9-84	Defined Parameters (5)	12-33	CIP Revision	14-03	Overmodulation	15-22	Historic Log: Value
8-37	Maximum Inter-Char Delay	9-85	Defined Parameters (6)	12-34	CIP Product Code	14-04	PWM Random	15-23	Historic log: Date and Time
8-4*	FC MC protocol set	9-90	Changed Parameters (1)	12-35	EDS Parameter	14-1*	Mains On/Off	15-3*	Alarm Log
8-40	Telegram Selection	9-91	Changed Parameters (2)	12-37	COS Inhibit Timer	14-10	Mains Failure	15-30	Alarm Log: Error Code
8-42	PCD Write Configuration	9-92	Changed Parameters (3)	12-37	COS Inhibit Timer	14-11	Mains Voltage at Mains Fault	15-31	Alarm Log: Value
8-43	PCD Read Configuration	9-93	Changed Parameters (4)	12-37	COS Inhibit Timer	14-12	Function at Mains Imbalance	15-32	Alarm Log: Time
8-5*	Digital/Bus	9-94	Changed Parameters (5)						
8-50	Coasting Select	9-99	Profibus Revision Counter						
8-52	DC Brake Select	10-*	CAN Fieldbus						

15-33 Alarm Log: Date and Time	16-18 Motor Thermal	16-96 Maintenance Word	20-96 PID Diff. Gain Limit	22-00 External Interlock Delay
15-34 Alarm Log: Setpoint	16-20 Motor Angle	18-** Info & Readouts	21-** Ext. Closed Loop	22-01 Power Filter Time
15-35 Alarm Log: Feedback	16-22 Torque [%]	18-0* Maintenance Log	21-0* Ext. CL Autotuning	22-2* No-Flow Detection
15-36 Alarm Log: Current Demand	16-26 Power Filtered [kW]	18-00 Maintenance Log: Item	21-00 Closed Loop Type	22-20 Low Power Auto Set-up
15-37 Alarm Log: Process Ctrl Unit	16-27 Power Filtered [hp]	18-01 Maintenance Log: Action	21-01 PID Performance	22-21 Low Power Detection
15-4* Drive Identification	16-3* Drive Status	18-02 Maintenance Log: Time	21-02 PID Output Change	22-22 Low Speed Detection
15-40 FC Type	16-30 DC Link Voltage	18-03 Maintenance Log: Date and Time	21-03 Minimum Feedback Level	22-23 No-Flow Function
15-41 Power Section	16-32 Brake Energy /s	18-3* Analog Readouts	21-04 Maximum Feedback Level	22-24 No-Flow Delay
15-42 Voltage	16-33 Brake Energy Average	18-30 Analog Input X42/1	21-09 PID Auto Tuning	22-26 Dry Pump Function
15-43 Software Version	16-34 Heatsink Temp.	18-31 Analog Input X42/3	21-1* Ext. CL 1 Ref./Fb.	22-27 Dry Pump Delay
15-44 Ordered Typecode String	16-35 Inverter Thermal	18-32 Analog Input X42/5	21-10 Ext. 1 Ref./Feedback Unit	22-28 No-Flow Low Speed [RPM]
15-45 Actual Typecode String	16-36 Inv. Nom. Current	18-33 Analog Out X42/7 [V]	21-11 Ext. 1 Minimum Reference	22-29 No-Flow Low Speed [Hz]
15-46 Frequency Converter Ordering No	16-37 Inv. Max. Current	18-34 Analog Out X42/9 [V]	21-12 Ext. 1 Maximum Reference	22-3* No-Flow Power Tuning
15-47 Power Card Ordering No	16-38 SL Controller State	18-35 Analog Out X42/11 [V]	21-13 Ext. 1 Reference Source	22-30 No-Flow Power
15-48 LCP Id No	16-39 Control Card Temp.	18-36 Analog Input X48/2 [mA]	21-14 Ext. 1 Feedback Source	22-31 Power Correction Factor
15-49 SW ID Control Card	16-40 Logging Buffer Full	18-37 Temp. Input X48/4	21-15 Ext. 1 Setpoint	22-32 Low Speed [RPM]
15-50 SW ID Power Card	16-49 Current Fault Source	18-38 Temp. Input X48/7	21-17 Ext. 1 Reference [Unit]	22-33 Low Speed [Hz]
15-51 Frequency Converter Serial Number	16-5* Ref. & Feeds.	18-39 Temp. Input X48/10	21-18 Ext. 1 Feedback [Unit]	22-34 Low Speed Power [kW]
15-53 Power Card Serial Number	16-50 External Reference	18-5* Sensorless Readout [unit]	21-19 Ext. 1 Output [%]	22-35 Low Speed Power [HP]
15-58 SmartStart Filename	16-52 Feedback[Unit]	18-6* Inputs & Outputs 2	21-2* Ext. CL 1 PID	22-36 High Speed [RPM]
15-59 CSV Filename	16-53 Digi Pot Reference	18-60 Digital Input 2	21-20 Ext. 1 Normal/Inverse Control	22-37 High Speed [Hz]
15-6* Option Ident	16-54 Feedback 1 [Unit]	20-** Drive Closed Loop	21-21 Ext. 1 Proportional Gain	22-38 High Speed Power [kW]
15-60 Option Mounted	16-55 Feedback 2 [Unit]	20-0* Feedback	21-22 Ext. 1 Integral Time	22-39 High Speed Power [HP]
15-61 Option SW Version	16-56 Feedback 3 [Unit]	20-00 Feedback 1 Source	21-23 Ext. 1 Differentiation Time	22-4* Sleep Mode
15-62 Option Ordering No	16-58 PID Output [%]	20-01 Feedback 1 Conversion	21-24 Ext. 1 Dif. Gain Limit	22-40 Minimum Run Time
15-63 Option Serial No	16-59 Adjusted Setpoint	20-02 Feedback 1 Source Unit	21-3* Ext. CL 2 Ref./Fb.	22-41 Minimum Sleep Time
15-70 Option in Slot A	16-6* Inputs & Outputs	20-03 Feedback 2 Source	21-30 Ext. 2 Ref./Feedback Unit	22-42 Wake-up Speed [RPM]
15-71 Slot A Option SW Version	16-60 Digital Input	20-04 Feedback 2 Conversion	21-31 Ext. 2 Minimum Reference	22-43 Wake-up Speed [Hz]
15-72 Option in Slot B	16-61 Terminal 53 Switch Setting	20-05 Feedback 2 Source Unit	21-32 Ext. 2 Maximum Reference	22-44 Wake-up Ref./FB Difference
15-73 Slot B Option SW Version	16-62 Analog Input 53	20-06 Feedback 3 Source	21-33 Ext. 2 Reference Source	22-45 Setpoint Boost
15-74 Option in Slot C0/EO	16-63 Terminal 54 Switch Setting	20-07 Feedback 3 Conversion	21-34 Ext. 2 Feedback Source	22-5* End of Curve
15-75 Slot C0/EO Option SW Version	16-64 Analog Input 54	20-08 Feedback 3 Source Unit	21-35 Ext. 2 Setpoint	22-50 End of Curve Function
15-76 Option in Slot C1/E1	16-65 Analog Output 42 [mA]	20-12 Reference/Feedback Unit	21-37 Ext. 2 Reference [Unit]	22-51 End of Curve Delay
15-77 Slot C1/E1 Option SW Version	16-66 Digital Output [bin]	20-2* Feedback/Setpoint	21-38 Ext. 2 Feedback [Unit]	22-6* Broken Belt Detection
15-8* Operating Data II	16-67 Pulse Input #29 [Hz]	20-20 Feedback Function	21-39 Ext. 2 Output [%]	22-60 Broken Belt Function
15-80 Fan Running Hours	16-68 Pulse Input #33 [Hz]	20-21 Setpoint 1	21-4* Ext. CL 2 PID	22-61 Broken Belt Torque
15-81 Preset Fan Running Hours	16-69 Pulse Output #27 [Hz]	20-22 Setpoint 2	21-40 Ext. 2 Normal/Inverse Control	22-62 Broken Belt Delay
15-9* Parameter Info	16-70 Pulse Output #29 [Hz]	20-23 Setpoint 3	21-41 Ext. 2 Proportional Gain	22-7* Short Cycle Protection
15-92 Defined Parameters	16-71 Relay Output [bin]	20-6* Sensorless	21-42 Ext. 2 Integral Time	22-75 Short Cycle Protection
15-93 Modified Parameters	16-72 Counter A	20-60 Sensorless Unit	21-43 Ext. 2 Differentiation Time	22-76 Interval between Starts
15-98 Drive Identification	16-73 Counter B	20-69 Sensorless Information	21-44 Ext. 2 Dif. Gain Limit	22-77 Minimum Run Time
15-99 Parameter Metadata	16-75 Analog In X30/11	20-7* PID Autotuning	21-5* Ext. CL 3 Ref./Fb.	22-78 Minimum Run Time Override
16-** Data Readouts	16-76 Analog In X30/12	20-70 Closed Loop Type	21-50 Ext. 3 Ref./Feedback Unit	22-79 Minimum Run Time Override Value
16-0* General Status	16-77 Analog Out X30/8 [mA]	20-71 PID Performance	21-51 Ext. 3 Minimum Reference	22-8* Flow Compensation
16-00 Control Word	16-78 Analog Out X45/1 [mA]	20-72 PID Output Change	21-52 Ext. 3 Maximum Reference	22-80 Flow Compensation
16-01 Reference [Unit]	16-79 Analog Out X45/3 [mA]	20-73 Minimum Feedback Level	21-53 Ext. 3 Reference Source	22-81 Square-linear Curve Approximation
16-02 Reference [%]	16-8* Fieldbus & FC Port	20-74 Maximum Feedback Level	21-54 Ext. 3 Feedback Source	22-82 Work Point Calculation
16-03 Status Word	16-80 Fieldbus CTW 1	20-79 PID Autotuning	21-55 Ext. 3 Setpoint	22-83 Speed at No-Flow [RPM]
16-05 Main Actual Value [%]	16-82 Fieldbus REF 1	20-8* PID Basic Settings	21-57 Ext. 3 Reference [Unit]	22-84 Speed at No-Flow [Hz]
16-09 Custom Readout	16-84 Comm. Option STW	20-81 PID Normal/ Inverse Control	21-58 Ext. 3 Feedback [Unit]	22-85 Speed at Design Point [RPM]
16-1* Motor Status	16-85 FC Port CTW 1	20-82 PID Start Speed [RPM]	21-59 Ext. 3 Output [%]	22-86 Speed at Design Point [Hz]
16-10 Power [kW]	16-86 FC Port REF 1	20-83 PID Start Speed [Hz]	21-6* Ext. CL 3 PID	22-87 Pressure at No-Flow Speed
16-11 Power [hp]	16-9* Diagnosis Readouts	20-84 On Reference Bandwidth	21-60 Ext. 3 Normal/Inverse Control	22-88 Pressure at Rated Speed
16-12 Motor Voltage	16-90 Alarm Word	20-89 PID Controller	21-61 Ext. 3 Proportional Gain	22-89 Flow at Design Point
16-13 Frequency	16-91 Alarm Word 2	20-91 PID Anti Windup	21-62 Ext. 3 Integral Time	22-90 Flow at Rated Speed
16-14 Motor current	16-92 Warning Word	20-93 PID Proportional Gain	21-63 Ext. 3 Differentiation Time	23-** Time-based Functions
16-15 Frequency [%]	16-93 Warning Word 2	20-94 PID Integral Time	21-64 Ext. 3 Dif. Gain Limit	23-0* Timed Actions
16-16 Torque [Nm]	16-94 Ext. Status Word	20-95 PID Differentiation Time	22-** Appl. Functions	23-00 ON Time
16-17 Speed [RPM]	16-95 Ext. Status Word 2		22-0* Miscellaneous	

23-01	ON Action	25-42	Staging Threshold	26-5*	Analog Out X42/9	27-58	Run Next Pump Delay	30-81	Brake Resistor (ohm)
23-02	OFF Time	25-43	Destaging Threshold	26-50	Terminal X42/9 Output	27-59	Digital Inputs	31-00	Bypass Option
23-03	OFF Action	25-44	Staging Speed [RPM]	26-51	Terminal X42/9 Min. Scale	27-60	Terminal X66/1 Digital Input	31-00	Bypass Mode
23-04	Occurrence	25-45	Staging Speed [Hz]	26-52	Terminal X42/9 Max. Scale	27-61	Terminal X66/3 Digital Input	31-01	Bypass Start Time Delay
23-1*	Maintenance	25-46	Destaging Speed [RPM]	26-53	Terminal X42/9 Bus Control	27-62	Terminal X66/5 Digital Input	31-02	Bypass Trip Time Delay
23-10	Maintenance Item	25-47	Destaging Speed [Hz]	26-54	Terminal X42/9 Timeout Preset	27-63	Terminal X66/7 Digital Input	31-03	Test Mode Activation
23-11	Maintenance Action	25-5*	Alternation Settings	26-6*	Analog Out X42/11	27-64	Terminal X66/9 Digital Input	31-10	Bypass Status Word
23-12	Maintenance Time Base	25-50	Lead Pump Alternation	26-60	Terminal X42/11 Output	27-65	Terminal X66/11 Digital Input	31-11	Bypass Running Hours
23-13	Maintenance Time Interval	25-51	Alternation Event	26-61	Terminal X42/11 Min. Scale	27-66	Terminal X66/13 Digital Input	31-19	Remote Bypass Activation
23-14	Maintenance Date and Time	25-52	Alternation Time Interval	26-62	Terminal X42/11 Max. Scale	27-67	Connections	35-0*	Sensor Input Option
23-15	Reset Maintenance Word	25-53	Alternation Timer Value	26-64	Terminal X42/11 Bus Control	27-70	Relay	35-0*	Temp. Input Mode
23-16	Maintenance Text	25-54	Alternation Predefined Time	27-0*	Cascade CTL Option	27-9*	Readouts	35-00	Term. X48/4 Temperature Unit
23-5*	Energy Log	25-55	Alternate if Load < 50%	27-01	Pump Status	27-91	Cascade Reference	35-01	Term. X48/4 Input Type
23-50	Energy Log Resolution	25-56	Staging Mode at Alternation	27-02	Current Pump Control	27-92	% Of Total Capacity	35-02	Term. X48/7 Temperature Unit
23-51	Period Start	25-58	Run Next Pump Delay	27-03	Manual Runtime Hours	27-93	Cascade Option Status	35-03	Term. X48/7 Input Type
23-53	Energy Log	25-59	Run on Mains Delay	27-04	Pump Total Lifetime Hours	27-94	Cascade System Status	35-04	Term. X48/10 Temperature Unit
23-54	Reset Energy Log	25-80	Cascade Status	27-10	Configuration	27-96	Extended Cascade Relay Output [bin]	35-05	Term. X48/10 Input Type
23-60	Trending	25-81	Pump Status	27-11	Cascade Controller	29-0*	Water Application Functions	35-1*	Temp. Input X48/4
23-61	Continuous Bin Data	25-82	Lead Pump	27-12	Number Of Drives	29-00	Pipe Fill	35-14	Term. X48/4 Filter Time Constant
23-62	Timed Bin Data	25-83	Relay Status	27-13	Number Of Pumps	29-01	Pipe Fill Enable	35-15	Term. X48/4 Temp. Monitor
23-63	Timed Period Start	25-84	Pump ON Time	27-14	Pump Capacity	29-02	Pipe Fill Speed [RPM]	35-16	Term. X48/4 Low Temp. Limit
23-64	Timed Period Stop	25-85	Relay ON Time	27-16	Runtime Balancing	29-03	Pipe Fill Speed [Hz]	35-17	Term. X48/4 High Temp. Limit
23-65	Minimum Bin Value	25-86	Reset Relay Counters	27-17	Motor Starters	29-04	Pipe Fill Rate	35-2*	Temp. Input X48/7
23-66	Reset Continuous Bin Data	25-90	Pump Interlock	27-18	Spin Time for Unused Pumps	29-05	Filled Setpoint	35-24	Term. X48/7 Filter Time Constant
23-67	Reset Timed Bin Data	25-91	Manual Alternation	27-19	Reset Current Runtime Hours	29-06	No-Flow Disable Timer	35-25	Term. X48/7 Temp. Monitor
23-8*	Playback Counter	26-0*	Analog I/O Option	27-2*	Bandwidth Settings	29-1*	Deragging Function	35-27	Term. X48/7 High Temp. Limit
23-80	Power Reference Factor	26-00	Terminal X42/1 Mode	27-20	Normal Operating Range	29-10	Derag Cycles	35-3*	Temp. Input X48/10
23-82	Investment	26-01	Terminal X42/3 Mode	27-21	Override Limit	29-11	Derag at Start/Stop	35-34	Term. X48/10 Filter Time Constant
23-83	Energy Savings	26-02	Terminal X42/5 Mode	27-22	Fixed Speed Only Operating Range	29-12	Deragging Run Time	35-35	Term. X48/10 Temp. Monitor
23-84	Cost Savings	26-03	Terminal X42/5 Mode	27-23	Staging Delay	29-13	Derag Speed [RPM]	35-36	Term. X48/10 Low Temp. Limit
24-1*	Appl. Functions 2	26-1*	Analog Input X42/1	27-24	Destaging Delay	29-14	Derag Speed [Hz]	35-37	Term. X48/10 High Temp. Limit
24-10	Drive Bypass	26-10	Terminal X42/1 Low Voltage	27-25	Override Hold Time	29-15	Derag Off Delay	35-4*	Analog Input X48/2
24-11	Drive Bypass Delay Time	26-11	Terminal X42/1 High Voltage	27-27	Min Speed Destage Delay	29-2*	Derag Power Tuning	35-42	Term. X48/2 Low Current
25-0*	System Settings	26-14	Terminal X42/1 Low Ref./Feedb. Value	27-3*	Staging Speed	29-20	Derag Power [kW]	35-43	Term. X48/2 High Current
25-00	Cascade Controller	26-15	Term. X42/1 High Ref./Feedb. Value	27-30	Auto Tune Staging Speeds	29-21	Derag Power [HP]	35-44	Term. X48/2 Low Ref./Feedb. Value
25-02	Motor Start	26-16	Term. X42/1 Filter Time Constant	27-31	Stage On Speed [RPM]	29-22	Derag Power Factor	35-45	Term. X48/2 High Ref./Feedb. Value
25-04	Pump Cycling	26-17	Term. X42/1 Live Zero	27-32	Stage On Speed [Hz]	29-24	Derag Power Delay	35-46	Term. X48/2 Filter Time Constant
25-05	Fixed Lead Pump	26-20	Terminal X42/3 Low Voltage	27-33	Stage Off Speed [RPM]	29-25	Low Speed [Hz]	35-47	Term. X48/2 Live Zero
25-06	Number of Pumps	26-21	Terminal X42/3 High Voltage	27-34	Stage Off Speed [Hz]	29-26	Low Speed Power [kW]		
25-20	Staging Bandwidth	26-24	Term. X42/3 Low Ref./Feedb. Value	27-4*	Staging Settings	29-27	Low Speed Power [HP]		
25-21	Override Bandwidth	26-25	Term. X42/3 High Ref./Feedb. Value	27-40	Auto Tune Staging Settings	29-28	High Speed Power [HP]		
25-22	Fixed Speed Bandwidth	26-26	Term. X42/3 Filter Time Constant	27-41	Ramp Down Delay	29-29	High Speed [RPM]		
25-23	SBW Staging Delay	26-27	Term. X42/3 Live Zero	27-42	Ramp Up Delay	29-30	High Speed [Hz]		
25-24	SBW Destaging Delay	26-3*	Analog Input X42/5	27-43	Staging Threshold	29-31	High Speed Power [kW]		
25-25	OBW Time	26-30	Terminal X42/5 Low Voltage	27-44	Destaging Threshold	29-32	High Speed Power [HP]		
25-26	Destage At No-Flow	26-31	Terminal X42/5 High Voltage	27-45	Destaging Speed [RPM]	29-33	Power Derag Limit		
25-27	Stage Function	26-34	Term. X42/5 Low Ref./Feedb. Value	27-47	Destaging Speed [RPM]	29-34	Consecutive Derag Interval		
25-28	Stage Function Time	26-35	Term. X42/5 High Ref./Feedb. Value	27-48	Destaging Speed [Hz]	29-4*	Pre/Post Lube		
25-29	Stage Function	26-37	Term. X42/5 Live Zero	27-50	Automatic Alternation	29-40	Pre/Post Lube Function		
25-30	Destage Function	26-40	Terminal X42/7 Output	27-51	Automatic Alternation Event	29-41	Pre Lube Time		
25-30	Destage Function Time	26-41	Terminal X42/7 Min. Scale	27-52	Alternation Time Interval	29-42	Post Lube Time		
25-40	Ramp Down Delay	26-42	Terminal X42/7 Max. Scale	27-53	Alternation Timer Value	29-5*	Flow Confirmation		
25-41	Ramp Up Delay	26-43	Terminal X42/7 Bus Control	27-54	Alternation At Time of Day	29-50	Validation Time		
		26-44	Terminal X42/7 Timeout Preset	27-55	Alternation Predefined Time	29-51	Verification Time		
				27-56	Alternate Capacity is <	30-3*	Special Features		
						30-8*	Compatibility (I)		

7 General Specifications

Mains Supply (L1-1, L2-1, L3-1, L1-2, L2-2, L3-2)

Supply voltage	380-500 V \pm 10%
Supply voltage	525-690 V \pm 10%

Mains voltage low/mains drop-out:

During low mains voltage or a mains drop-out, the frequency converter continues until the intermediate circuit voltage drops below the minimum stop level, which corresponds typically to 15% below the frequency converter's lowest rated supply voltage. Power-up and full torque cannot be expected at mains voltage lower than 10% below the frequency converter's lowest rated supply voltage.

Supply frequency	50/60 Hz \pm 5%
Max. imbalance temporary between mains phases	3.0 % of rated supply voltage
True Power Factor (λ)	\geq 0.9 nominal at rated load
Displacement Power Factor ($\cos\phi$) near unity	(> 0.98)
Switching on input supply L1, L2, L3 (power-ups)	maximum once/2 min.
Environment according to EN60664-1	overvoltage category III / pollution degree 2

The unit is suitable for use on a circuit capable of delivering not more than 100.000 RMS symmetrical Amperes, 480/690 V maximum.

Motor output (U, V, W)

Output voltage	0-100% of supply voltage
Output frequency	0-800* Hz
Switching on output	Unlimited
Ramp times	1-3600 s

* Voltage and power dependent

Torque characteristics

Starting torque (constant torque)	maximum 110% for 1 min.*
Starting torque	maximum 135% up to 0.5 s*
Overload torque (constant torque)	maximum 110% for 1 min.*

*Percentage relates to the frequency converter's nominal torque.

Cable lengths and cross-sections

Max. motor cable length, screened/armoured	150 m
Max. motor cable length, unscreened/unarmoured	300 m
Max. cross section to motor, mains, load sharing and brake *	
Maximum cross section to control terminals, rigid wire	1.5 mm ² /16 AWG (2x0.75 mm ²)
Maximum cross section to control terminals, flexible cable	1 mm ² /18 AWG
Maximum cross section to control terminals, cable with enclosed core	0.5 mm ² /20 AWG
Minimum cross section to control terminals	0.25 mm ²

* See chapter 7.1.1 Mains Supply 3 x 380 - 500V AC - High Power and chapter 7.1.1 Electrical Data - 525 - 690 VAC for more information.

Digital inputs

Programmable digital inputs	4 (6)
Terminal number	18, 19, 27 ¹⁾ , 29 ¹⁾ , 32, 33,
Logic	PNP or NPN
Voltage level	0-24 V DC
Voltage level, logic '0' PNP	<5 V DC
Voltage level, logic '1' PNP	>10 V DC
Voltage level, logic '0' NPN	>19 V DC
Voltage level, logic '1' NPN	<14 V DC
Maximum voltage on input	28 V DC

Input resistance, R_i approx. 4 k Ω

All digital inputs are galvanically isolated from the supply voltage (PELV) and other high-voltage terminals.

1) Terminals 27 and 29 can also be programmed as output.

Analog inputs

Number of analog inputs 2

Terminal number 53, 54

Modes Voltage or current

Mode select Switches S201 and S202

Voltage mode Switch S201/S202 = OFF (U)

Voltage level 0-10 V (scaleable)

Input resistance, R_i approx. 10 k Ω

Maximum voltage ± 20 V

Current mode Switch S201/S202 = ON (I)

Current level 0/4-20 mA (scaleable)

Input resistance, R_i approx. 200 Ω

Maximum current 30 mA

Resolution for analog inputs 10 bit (+ sign)

Accuracy of analog inputs Maximum error 0.5% of full scale

Bandwidth 200 Hz

The analog inputs are galvanically isolated from the supply voltage (PELV) and other high-voltage terminals.

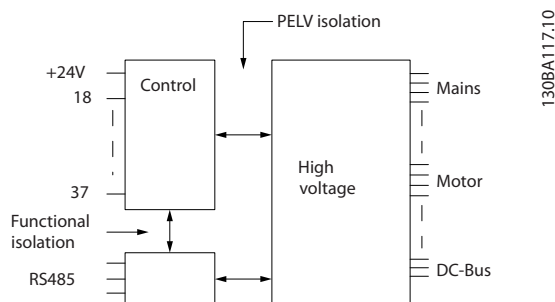

Illustration 7.1 PELV Isolation of Analog Inputs

Pulse inputs

Programmable pulse inputs 2

Terminal number pulse 29, 33

Maximum frequency at terminal 29, 33 110 kHz (push-pull driven)

Maximum frequency at terminal 29, 33 5 kHz (open collector)

Minimum frequency at terminal 29, 33 4 Hz

Voltage level see *Digital inputs*

Maximum voltage on input 28 V DC

Input resistance, R_i approx. 4 k Ω

Pulse input accuracy (0.1-1 kHz) Maximum error 0.1% of full scale

Analog output

Number of programmable analog outputs 1

Terminal number 42

Current range at analog output 0/4-20 mA

Maximum resistor load to common at analog output 500 Ω

Accuracy on analog output Maximum error 0.8% of full scale

Resolution on analog output 8 bit

The analog output is galvanically isolated from the supply voltage (PELV) and other high-voltage terminals.

Control card, RS-485 serial communication

Terminal number 68 (P,TX+, RX+), 69 (N,TX-, RX-)

Terminal number 61 Common for terminals 68 and 69

The RS-485 serial communication circuit is functionally separated from other central circuits and galvanically isolated from the supply voltage (PELV).

Digital output

Programmable digital/pulse outputs 2

Terminal number 27, 29¹⁾

Voltage level at digital/frequency output 0-24 V

Maximum output current (sink or source) 40 mA

Maximum load at frequency output 1 k Ω

Maximum capacitive load at frequency output 10 nF

Minimum output frequency at frequency output 0 Hz

Maximum output frequency at frequency output 32 kHz

Accuracy of frequency output Maximum error 0.1% of full scale

Resolution of frequency outputs 12 bit

1) Terminal 27 and 29 can also be programmed as input.

The digital output is galvanically isolated from the supply voltage (PELV) and other high-voltage terminals.

Control card, 24 V DC output

Terminal number 12, 13

Maximum load 200 mA

The 24 V DC supply is galvanically isolated from the supply voltage (PELV), but has the same potential as the analog and digital inputs and outputs.

Relay outputs

Programmable relay outputs 2

Relay 01 Terminal number 1-3 (break), 1-2 (make)

Maximum terminal load (AC-1)¹⁾ on 1-3 (NC), 1-2 (NO) (Resistive load) 240 V AC, 2 A

Maximum terminal load (AC-15)¹⁾ on 1-3 (NC), 1-2 (NO) (Inductive load @ cos ϕ 0.4) 240 V AC, 0.2 A

Maximum terminal load (DC-1)¹⁾ on 1-2 (NO), 1-3 (NC) (Resistive load) 60 V DC, 1 A

Maximum terminal load (DC-13)¹⁾ on 1-2 (NO), 1-3 (NC) (Inductive load) 24 V DC, 0.1 A

Relay 02 Terminal number 4-6 (break), 4-5 (make)

Maximum terminal load (AC-1)¹⁾ on 4-5 (NO) (Resistive load)²⁾³⁾ 400 V AC, 2 A

Maximum terminal load (AC-15)¹⁾ on 4-5 (NO) (Inductive load @ cos ϕ 0.4) 240 V AC, 0.2 A

Maximum terminal load (DC-1)¹⁾ on 4-5 (NO) (Resistive load) 80 V DC, 2 A

Maximum terminal load (DC-13)¹⁾ on 4-5 (NO) (Inductive load) 24 V DC, 0.1 A

Maximum terminal load (AC-1)¹⁾ on 4-6 (NC) (Resistive load) 240 V AC, 2 A

Maximum terminal load (AC-15)¹⁾ on 4-6 (NC) (Inductive load @ cos ϕ 0.4) 240 V AC, 0.2 A

Maximum terminal load (DC-1)¹⁾ on 4-6 (NC) (Resistive load) 50 V DC, 2 A

Maximum terminal load (DC-13)¹⁾ on 4-6 (NC) (Inductive load) 24 V DC, 0.1 A

Minimum terminal load on 1-3 (NC), 1-2 (NO), 4-6 (NC), 4-5 (NO) 24 V DC, 10 mA, 24 V AC, 20 mA

Environment according to EN 60664-1 overvoltage category III/pollution degree 2

1) IEC 60947 parts 4 and 5

The relay contacts are galvanically isolated from the rest of the circuit by reinforced isolation (PELV).

2) Overvoltage Category II

3) UL applications 300 V AC 2 A

Control card, 10 V DC output

Terminal number	50
Output voltage	10.5 V ±0.5 V
Maximum load	25 mA

The 10 V DC supply is galvanically isolated from the supply voltage (PELV) and other high-voltage terminals.

Control characteristics

Resolution of output frequency at 0-590 Hz	±0.003 Hz
System response time (terminals 18, 19, 27, 29, 32, 33)	≤2 ms
Speed control range (open loop)	1:100 of synchronous speed
Speed accuracy (open loop)	30-4000 RPM: Maximum error of ±8 RPM

All control characteristics are based on a 4-pole asynchronous motor.

Surroundings

Enclosure, frame size E	IP00, IP21, IP54
Enclosure, frame size F	IP21, IP54
Vibration test	0.7 g
Relative humidity	5% - 95% (IEC 721-3-3; Class 3K3 (non-condensing) during operation
Aggressive environment (IEC 60068-2-43) H ₂ S test	class kD
Test method according to IEC 60068-2-43 H ₂ S (10 days)	
Ambient temperature (at 60 AVM switching mode)	
- with derating	max. 55 °C ¹⁾
- with full output power, typical EFF2 motors	max. 50 °C ¹⁾
- at full continuous FC output current	max. 45 °C ¹⁾

¹⁾ For more information on derating see the Design Guide, section on Special Conditions.

Minimum ambient temperature during full-scale operation	0 °C
Minimum ambient temperature at reduced performance	-10 °C
Temperature during storage/transport	-25 to +65/70 °C
Maximum altitude above sea level without derating	1000 m
Maximum altitude above sea level with derating	3000 m

Derating for high altitude, see section on special conditions in the Design Guide

EMC standards, Emission	EN 61800-3, EN 61000-6-3/4, EN 55011, IEC 61800-3 EN 61800-3, EN 61000-6-1/2,
EMC standards, Immunity	EN 61000-4-2, EN 61000-4-3, EN 61000-4-4, EN 61000-4-5, EN 61000-4-6

See section on special conditions in the Design Guide!

Control card performance

Scan interval	5 ms
Control card, USB serial communication	
USB standard	1.1 (Full speed)
USB plug	USB type B "device" plug

CAUTION

Connection to PC is carried out via a standard host/device USB cable.

The USB connection is galvanically isolated from the supply voltage (PELV) and other high-voltage terminals.

The USB connection is NOT galvanically isolated from protective earth. Use only isolated laptop/PC as connection to the USB connector on the frequency converter or an isolated USB cable/converter.

Protection and features

- Electronic thermal motor protection against overload.
- Temperature monitoring of the heat sink ensures that the frequency converter trips if the temperature reaches a predefined level. An overload temperature cannot be reset until the temperature of the heat sink is below the

values stated in the tables on the following pages (Guideline - these temperatures may vary for different power sizes, frame sizes, enclosure ratings etc.).

- The frequency converter is protected against short circuits on motor terminals U, V, W.
- If a mains phase is missing, the frequency converter trips or issues a warning (depending on the load).
- Monitoring of the intermediate circuit voltage ensures that the frequency converter trips if the intermediate circuit voltage is too low or too high.
- The frequency converter is protected against ground faults on motor terminals U, V, W.

Mains Supply 6 x 380 - 500V AC				
	P315	P355	P400	P450
Typical Shaft output at 400 V [kW]	315	355	400	450
Typical Shaft output at 460 V [HP]	450	500	600	600
Typical Shaft output at 500 V [kW]	355	400	500	530
Enclosure IP21	F8/F9	F8/F9	F8/F9	F8/F9
Enclosure IP54	F8/F9	F8/F9	F8/F9	F8/F9
Output current				
Continuous (at 400 V) [A]	600	648	745	800
Intermittent (60 sec overload) (at 400 V) [A]	660	724	820	880
Continuous (at 460/ 500 V) [A]	540	590	678	730
Intermittent (60 sec overload) (at 460/ 500 V) [A]	594	649	746	803
Continuous KVA (at 400 V) [KVA]	416	456	516	554
Continuous KVA (at 460 V) [KVA]	430	470	540	582
Continuous KVA (at 500 V) [KVA]	468	511	587	632
Max. input current				
Continuous (at 400 V) [A]	590	647	733	787
Continuous (at 460/ 500 V) [A]	531	580	667	718
Max. cable size, mains [mm ² (AWG ²)]	4x90 (3/0)	4x90 (3/0)	4x240 (500 mcm)	4x240 (500 mcm)
Max. cable size, motor [mm ² (AWG ²)]	4x240 (4x500 mcm)	4x240 (4x500 mcm)	4x240 (4x500 mcm)	4x240 (4x500 mcm)
Max. cable size, brake [mm ² (AWG ²)]	2 x 185 (2 x 350 mcm)	2 x 185 (2 x 350 mcm)	2 x 185 (2 x 350 mcm)	2 x 185 (2 x 350 mcm)
Max. external mains fuses [A] ¹	700			
Estimated power loss at 400 V [W] ⁴⁾	6790	7701	8879	9670
Estimated power loss at 460 V [W]	6082	6953	8089	8803
Weight, enclosure IP21, IP 54 [kg]	440/656			
Efficiency ⁴⁾	0.98			
Output frequency	0 - 600Hz			
Heatsink overtemp. trip	95 °C			
Power card ambient trip	68 °C			

* High overload = 160% torque during 60 sec, Normal overload = 110% torque during 60 sec.

7

Table 7.1

Mains Supply 6 x 380 - 500V AC						
	P500	P560	P630	P710	P800	P1000
Typical Shaft output at 400 V [kW]	500	560	630	710	800	1000
Typical Shaft output at 460 V [HP]	650	750	900	1000	1200	1350
Typical Shaft output at 500 V [kW]	560	630	710	800	1000	1100
Enclosure IP21, 54 without/with options cabinet	F10/F11	F10/F11	F10/F11	F10/F11	F12/F13	F12/F13
Output current						
Continuous (at 400 V) [A]	880	990	1120	1260	1460	1720
Intermittent (60 sec overload) (at 400 V) [A]	968	1089	1232	1386	1606	1892
Continuous (at 460/ 500 V) [A]	780	890	1050	1160	1380	1530
Intermittent (60 sec overload) (at 460/ 500 V) [A]	858	979	1155	1276	1518	1683
Continuous KVA (at 400 V) [KVA]	610	686	776	873	1012	1192
Continuous KVA (at 460 V) [KVA]	621	709	837	924	1100	1219
Continuous KVA (at 500 V) [KVA]	675	771	909	1005	1195	1325
Max. input current						
Continuous (at 400 V) [A]	857	964	1090	1227	1422	1675
Continuous (at 460/ 500 V) [A]	759	867	1022	1129	1344	1490
Max. cable size,motor [mm ² (AWG ²)]	8x150 (8x300 mcm)			12x150 (12x300 mcm)		
Max. cable size,mains [mm ² (AWG ²)]	6x120 (6x250 mcm)					
Max. cable size, brake [mm ² (AWG ²)]	4x185 (4x350 mcm)			6x185 (6x350 mcm)		
Max. external mains fuses [A] 1)	900			1500		
Estimated power loss at 400 V [W] ⁴⁾	10647	12338	13201	15436	18084	20358
Estimated power loss at 460 V [W]	9414	11006	12353	14041	17137	17752
F9/F11/F13 max. added losses A1 RFI, CB or Disconnect, & contactor F9/F11/F13	963	1054	1093	1230	2280	2541
Max. panel options losses	400					
Weight, enclosure IP21, IP54 [kg]	1004/ 1299	1004/ 1299	1004/ 1299	1004/ 1299	1246/ 1541	1246/ 1541
Weight rectifier module [kg]	102	102	102	102	136	136
Weight inverter module [kg]	102	102	102	136	102	102
Efficiency ⁴⁾	0.98					
Output frequency	0-600Hz					
Heatsink overtemp. trip	95 °C					
Power card ambient trip	68 °C					

* High overload = 160% torque during 60 sec., Normal overload = 110% torque during 60 sec.

Table 7.2

Mains Supply 3 x 525- 690V AC				
	P450	P500	P560	P630
Typical Shaft output at 550 V [kW]	355	400	450	500
Typical Shaft output at 575 V [HP]	450	500	600	650
Typical Shaft output at 690 V [kW]	450	500	560	630
Enclosure IP21	F8/F9	F8/F9	F8/F9	F8/F9
Enclosure IP54	F8/F9	F8/F9	F8/F9	F8/F9
Output current				
Continuous (at 550 V) [A]	470	523	596	630
Intermittent (60 sec overload) (at 550 V) [A]	517	575	656	693
Continuous (at 575/ 690 V) [A]	450	500	570	630
Intermittent (60 sec overload) (at 575/ 690 V) [A]	495	550	627	693
Continuous KVA (at 550 V) [KVA]	448	498	568	600
Continuous KVA (at 575 V) [KVA]	448	498	568	627
Continuous KVA (at 690 V) [KVA]	538	598	681	753
Max. input current				
Continuous (at 550 V) [A]	453	504	574	607
Continuous (at 575 V) [A]	434	482	549	607
Continuous (at 690 V) [A]	434	482	549	607
Max. cable size, mains [mm ² (AWG)]	4x85 (3/0)			
Max. cable size, motor [mm ² (AWG)]	4 x 250 (500 mcm)			
Max. cable size, brake [mm ² (AWG)]	2 x 185 (2 x 350 mcm)	2 x 185 (2 x 350 mcm)	2 x 185 (2 x 350 mcm)	2 x 185 (2 x 350 mcm)
Max. external mains fuses [A] ¹	630			
Estimated power loss at 600 V [W] ⁴⁾	6132	6903	8343	9244
Estimated power loss at 690 V [W] ⁴⁾	6449	7249	8727	9673
Weight, enclosure IP21, IP 54 [kg]	440/656			
Efficiency ⁴⁾	0.98			
Output frequency	0 - 500 Hz			
Heatsink overtemp. trip	85 °C			
Power card ambient trip	68 °C			

* High overload = 160% torque during 60 sec, Normal overload = 110% torque during 60 sec.

Table 7.3

Mains Supply 3 x 525- 690V AC			
	P710	P800	P900
Typical Shaft output at 550 V [kW]	560	670	750
Typical Shaft output at 575 V [HP]	750	950	1050
Typical Shaft output at 690 V [kW]	710	800	900
Enclosure IP21, 54 without/ with options cabinet	F10/F11	F10/F11	F10/F11
Output current			
Continuous (at 550 V) [A]	763	889	988
Intermittent (60 sec overload) (at 550 V) [A]	839	978	1087
Continuous (at 575/ 690 V) [A]	730	850	945
Intermittent (60 sec overload) (at 575/ 690 V) [A]	803	935	1040
Continuous KVA (at 550 V) [KVA]	727	847	941
Continuous KVA (at 690 V) [KVA]	872	1016	1129
Max. input current			
Continuous (at 550 V) [A]	743	866	962
Continuous (at 575 V) [A]	711	828	920
Continuous (at 690 V) [A]	711	828	920
Max. cable size, motor [mm ² (AWG ²)]	8x150 (8x300 mcm)		
Max. cable size,mains [mm ² (AWG ²)]	6x120 (6x250 mcm)		
Max. cable size, brake [mm ² (AWG ²)]	4x185 (4x350 mcm)		
Max. external mains fuses [A] ¹	900		
Estimated power loss at 600 V [W] ⁴⁾	10771	12272	13835
Estimated power loss at 690V [W] ⁴⁾	11315	12903	14533
F3/F4 Max added losses CB or Disconnect & Contactor	427	532	615
Max panel options losses	400		
Weight, enclosure IP21, IP 54 [kg]	1004/ 1299	1004/ 1299	1004/ 1299
Weight, Rectifier Module [kg]	102	102	102
Weight, Inverter Module [kg]	102	102	136
Efficiency ⁴⁾	0.98		
Output frequency	0-500 Hz		
Heatsink overtemp. trip	85 °C		
Power card ambient trip	68 °C		

* High overload = 160% torque during 60 sec., Normal overload = 110% torque during 60 sec.

Table 7.4

Mains Supply 3 x 525- 690V AC			
	P1M0	P1M2	P1M4
Typical Shaft output at 550 V [kW]	850	1000	1100
Typical Shaft output at 575 V [HP]	1150	1350	1550
Typical Shaft output at 690 V [kW]	1000	1200	1400
Enclosure IP21, 54 without/ with options cabinet	F12/F13	F12/F13	F12/F13
Output current			
Continuous (at 550 V) [A]	1108	1317	1479
Intermittent (60 sec overload) (at 550 V) [A]	1219	1449	1627
Continuous (at 575/ 690 V) [A]	1060	1260	1415
Intermittent (60 sec overload) (at 575/ 690 V) [A]	1166	1386	1557
Continuous KVA (at 550 V) [KVA]	1056	1255	1409
Continuous KVA (at 690 V) [KVA]	1267	1506	1691
Max. input current			
Continuous (at 550 V) [A]	1079	1282	1440
Continuous (at 575 V) [A]	1032	1227	1378
Continuous (at 690 V) [A]	1032	1227	1378
Max. cable size, motor [mm ² (AWG ²)]	12x150 (12x300 mcm)		
Max. cable size,mains F12 [mm ² (AWG ²)]	8x240 (8x500 mcm)		
Max. cable size,mains F13 [mm ² (AWG ²)]	8x400 (8x900 mcm)		
Max. cable size, brake [mm ² (AWG ²)]	6x185 (6x350 mcm)		
Max. external mains fuses [A] ¹	1600	2000	2500
Estimated power loss at 600 V [W] ⁴⁾	15592	18281	20825
Estimated power loss at 690V [W] ⁴⁾	16375	19207	21857
F3/F4 Max added losses CB or Disconnect & Contactor	665	863	1044
Max panel options losses	400		
Weight, enclosure IP21, IP 54 [kg]	1246/ 1541	1246/ 1541	1280/1575
Weight, Rectifier Module [kg]	136	136	136
Weight, Inverter Module [kg]	102	102	136
Efficiency ⁴⁾	0.98		
Output frequency	0-500 Hz		
Heatsink overtemp. trip	85 °C		
Power card ambient trip	68 °C		
* High overload = 160% torque during 60 sec., Normal overload = 110% torque during 60 sec.			

7

Table 7.5

1) For type of fuse see section *Fuses*.

2) American Wire Gauge.

3) Measured using 5 m screened motor cables at rated load and rated frequency.

4) The typical power loss is at nominal load conditions and expected to be within +/-15% (tolerance relates to variety in voltage and cable conditions).

Values are based on a typical motor efficiency (eff2/eff3 border line). Motors with lower efficiency will also add to the power loss in the frequency converter and opposite.

If the switching frequency is increased compared to the default setting, the power losses may rise significantly.

LCP and typical control card power consumptions are included. Further options and customer load may add up to 30W to the losses. (Though typical only 4W extra for a fully loaded control card, or options for slot A or slot B, each).

Although measurements are made with state of the art equipment, some measurement inaccuracy must be allowed for (+/-5%).

8 Troubleshooting

8.1 Alarms and Warnings

A warning or an alarm is signalled by the relevant LED on the front of the frequency converter and indicated by a code on the display.

A warning remains active until its cause is no longer present. Under certain circumstances operation of the motor may still be continued. Warning messages may be critical, but are not necessarily so.

In the event of an alarm, the frequency converter will have tripped. Alarms must be reset to restart operation once their cause has been rectified.

This may be done in 4 ways:

1. By pressing [RESET] on the LCP.
2. Via a digital input with the "Reset" function.
3. Via serial communication/optional fieldbus.
4. By resetting automatically using the [Auto Reset] function. See *14-20 Reset Mode in VLT® AQUA Drive FC 202 Programming Guide*

NOTICE

After a manual reset pressing [RESET] on the LCP, press [AUTO ON] or [HAND ON] to restart the motor.

If an alarm cannot be reset, the reason may be that its cause has not been rectified, or the alarm is trip-locked (see also table on following page).

Alarms that are trip-locked offer additional protection, means that the mains supply must be switched off before the alarm can be reset. After being switched back on, the frequency converter is no longer blocked and may be reset as described above once the cause has been rectified.

Alarms that are not trip-locked can also be reset using the automatic reset function in *14-20 Reset Mode* (Warning: automatic wake-up is possible!)

If a warning and alarm is marked against a code in the table on the following page, this means that either a warning occurs before an alarm, or it can be specified whether it is a warning or an alarm that is to be displayed for a given fault.

This is possible, for instance, in *1-90 Motor Thermal Protection*. After an alarm or trip, the motor carries on coasting, and the alarm and warning flash on the frequency converter. Once the problem has been rectified, only the alarm continues flashing.



No.	Description	Warning	Alarm/Trip	Alarm/Trip Lock	Parameter Reference
1	10 Volts low	X			
2	Live zero error	(X)	(X)		6-01
3	No motor	(X)			1-80
4	Mains phase loss	(X)	(X)	(X)	14-12
5	DC link voltage high	X			
6	DC link voltage low	X			
7	DC over voltage	X	X		
8	DC under voltage	X	X		
9	Inverter overloaded	X	X		
10	Motor ETR over temperature	(X)	(X)		1-90
11	Motor thermistor over temperature	(X)	(X)		1-90
12	Torque limit	X	X		
13	Over Current	X	X	X	
14	Earth fault	X	X	X	
15	Hardware mismatch		X	X	
16	Short Circuit		X	X	
17	Control word timeout	(X)	(X)		8-04
23	Internal Fan Fault	X			
24	External Fan Fault	X			14-53
25	Brake resistor short-circuited	X			
26	Brake resistor power limit	(X)	(X)		2-13
27	Brake chopper short-circuited	X	X		

No.	Description	Warning	Alarm/Trip	Alarm/Trip Lock	Parameter Reference
28	Brake check	(X)	(X)		2-15
29	Drive over temperature	X	X	X	
30	Motor phase U missing	(X)	(X)	(X)	4-58
31	Motor phase V missing	(X)	(X)	(X)	4-58
32	Motor phase W missing	(X)	(X)	(X)	4-58
33	Inrush fault		X	X	
34	Fieldbus communication fault	X	X		
35	Out of frequency range	X	X		
36	Mains failure	X	X		
37	Phase Imbalance	X	X		
39	Heatsink sensor		X	X	
40	Overload of Digital Output Terminal 27	(X)			5-00, 5-01
41	Overload of Digital Output Terminal 29	(X)			5-00, 5-02
42	Overload of Digital Output On X30/6	(X)			5-32
42	Overload of Digital Output On X30/7	(X)			5-33
46	Pwr. card supply		X	X	
47	24 V supply low	X	X	X	
48	1.8 V supply low		X	X	
49	Speed limit	X			
50	AMA calibration failed		X		
51	AMA check U_{nom} and I_{nom}		X		
52	AMA low I_{nom}		X		
53	AMA motor too big		X		
54	AMA motor too small		X		
55	AMA parameter out of range		X		
56	AMA interrupted by user		X		
57	AMA timeout		X		
58	AMA internal fault	X	X		
59	Current limit	X			
60	External Interlock	X			
62	Output Frequency at Maximum Limit	X			
64	Voltage Limit	X			
65	Control Board Over-temperature	X	X	X	
66	Heat sink Temperature Low	X			
67	Option Configuration has Changed		X		
68	Safe Stop Activated		X ¹⁾		
69	Pwr. Card Temp		X	X	
70	Illegal FC configuration			X	
71	PTC 1 Safe Stop	X	X ¹⁾		
72	Dangerous Failure			X ¹⁾	
73	Safe Stop Auto Restart				
76	Power Unit Setup	X			
79	Illegal PS config		X	X	
80	Drive Initialised to Default Value		X		
91	Analog input 54 wrong settings			X	
92	NoFlow	X	X		22-2*
93	Dry Pump	X	X		22-2*
94	End of Curve	X	X		22-5*
95	Broken Belt	X	X		22-6*
96	Start Delayed	X			22-7*
97	Stop Delayed	X			22-7*
98	Clock Fault	X			0-7*

No.	Description	Warning	Alarm/Trip	Alarm/Trip Lock	Parameter Reference
220	Overload Trip		X		
243	Brake IGBT	X	X		
244	Heatsink temp	X	X	X	
245	Heatsink sensor		X	X	
246	Pwr.card supply		X	X	
247	Pwr.card temp		X	X	
248	Illegal PS config		X	X	
250	New spare part			X	
251	New Type Code		X	X	

Table 8.1 Alarm/Warning Code List

(X) Dependent on parameter

1) Cannot be Auto reset via 14-20 Reset Mode

A trip is the action when an alarm has appeared. The trip coasts the motor and can be reset by pressing [Reset] or making a reset by a digital input (Par. 5-1* *Digital Inputs [1] Reset*). The origin event that caused an alarm cannot damage the frequency converter or cause dangerous conditions. A trip lock is an action when an alarm occurs, which may cause damage to frequency converter or connected parts. A Trip Lock situation can only be reset by a power cycling.

LED indication	
Warning	yellow
Alarm	flashing red
Trip locked	yellow and red

Table 8.2

Alarm Word and Extended Status Word					
Bit	Hex	Dec	Alarm Word	Warning Word	Extended Status Word
0	00000001	1	Brake Check	Brake Check	Ramping
1	00000002	2	Pwr. Card Temp	Pwr. Card Temp	AMA Running
2	00000004	4	Earth Fault	Earth Fault	Start CW/CCW
3	00000008	8	Ctrl.Card Temp	Ctrl.Card Temp	Slow Down
4	00000010	16	Ctrl. Word TO	Ctrl. Word TO	Catch Up
5	00000020	32	Over Current	Over Current	Feedback High
6	00000040	64	Torque Limit	Torque Limit	Feedback Low
7	00000080	128	Motor Th Over	Motor Th Over	Output Current High
8	00000100	256	Motor ETR Over	Motor ETR Over	Output Current Low
9	00000200	512	Inverter Overld.	Inverter Overld.	Output Freq High
10	00000400	1024	DC under Volt	DC under Volt	Output Freq Low
11	00000800	2048	DC over Volt	DC over Volt	Brake Check OK
12	00001000	4096	Short Circuit	DC Voltage Low	Braking Max
13	00002000	8192	Inrush Fault	DC Voltage High	Braking
14	00004000	16384	Mains ph. Loss	Mains ph. Loss	Out of Speed Range
15	00008000	32768	AMA Not OK	No Motor	OVC Active
16	00010000	65536	Live Zero Error	Live Zero Error	
17	00020000	131072	Internal Fault	10V Low	
18	00040000	262144	Brake Overload	Brake Overload	
19	00080000	524288	U phase Loss	Brake Resistor	
20	00100000	1048576	V phase Loss	Brake IGBT	
21	00200000	2097152	W phase Loss	Speed Limit	
22	00400000	4194304	Fieldbus Fault	Fieldbus Fault	
23	00800000	8388608	24 V Supply Low	24V Supply Low	
24	01000000	16777216	Mains Failure	Mains Failure	
25	02000000	33554432	1.8V Supply Low	Current Limit	
26	04000000	67108864	Brake Resistor	Low Temp	
27	08000000	134217728	Brake IGBT	Voltage Limit	
28	10000000	268435456	Option Change	Unused	
29	20000000	536870912	Drive Initialised	Unused	
30	40000000	1073741824	Safe Stop	Unused	

Table 8.3 Description of Alarm Word, Warning Word and Extended Status Word

The alarm words, warning words and extended status words can be read out via serial bus or optional fieldbus for diagnosis. See also *16-90 Alarm Word*, *16-92 Warning Word* and *16-94 Ext. Status Word*.

WARNING 1, 10 Volts low

The control card voltage is <10 V from terminal 50. Remove some of the load from terminal 50, as the 10 V supply is overloaded. Maximum 15 mA or minimum 590 Ω.

A short-circuit in a connected potentiometer or improper wiring of the potentiometer can cause this condition.

Troubleshooting

- Remove the wiring from terminal 50. If the warning clears, the problem is with the wiring. If the warning does not clear, replace the control card.

WARNING/ALARM 2, Live zero error

This warning or alarm only appears if programmed in *parameter 6-01 Live Zero Timeout Function*. The signal on one of the analog inputs is less than 50% of the minimum value programmed for that input. Broken wiring or a faulty device sending the signal can cause this condition.

Troubleshooting

- Check the connections on all the analog input terminals.
 - Control card terminals 53 and 54 for signals, terminal 55 common.
 - MCB 101 terminals 11 and 12 for signals, terminal 10 common.
 - MCB 109 terminals 1, 3, 5 for signals, terminals 2, 4, 6 common.
- Check that the frequency converter programming and switch settings match the analog signal type.
- Perform an input terminal signal test.

WARNING/ALARM 3, No motor

No motor has been connected to the output of the frequency converter.

WARNING/ALARM 4, Mains phase loss

A phase is missing on the supply side, or the mains voltage imbalance is too high. This message also appears for a fault in the input rectifier on the frequency converter. Options are programmed in *14-12 Function at Mains Imbalance*.

Troubleshooting

- Check the supply voltage and supply currents to the frequency converter.

WARNING 5, DC link voltage high

The intermediate circuit voltage (DC) is higher than the high-voltage warning limit. The limit is dependent on the frequency converter voltage rating. The unit is still active.

WARNING 6, DC link voltage low

The intermediate circuit voltage (DC) is lower than the low-voltage warning limit. The limit is dependent on the frequency converter voltage rating. The unit is still active.

WARNING/ALARM 7, DC overvoltage

If the intermediate circuit voltage exceeds the limit, the frequency converter trips after a time.

Troubleshooting

- Connect a brake resistor
- Extend the ramp time.
- Change the ramp type.
- Activate the functions in *2-10 Brake Function*.
- Increase *14-26 Trip Delay at Inverter Fault*
- If the alarm/warning occurs during a power sag, use kinetic back-up (*14-10 Mains Failure*).

WARNING/ALARM 8, DC under voltage

If the DC-link voltage drops below the undervoltage limit, the frequency converter checks if a 24 V DC backup supply is connected. If no 24 V DC backup supply is connected, the frequency converter trips after a fixed time delay. The time delay varies with unit size.

Troubleshooting

- Check that the supply voltage matches the frequency converter voltage.
- Perform an input voltage test.
- Perform a soft charge circuit test.

WARNING/ALARM 9, Inverter overload

The frequency converter is about to cut out because of an overload. The counter for electronic, thermal inverter protection issues a warning at 98% and trips at 100%, while giving an alarm. The frequency converter cannot be reset until the counter is below 90%.

The fault is that the frequency converter has run with more than 100% overload for too long.

Troubleshooting

- Compare the output current shown on the LCP with the frequency converter rated current.
- Compare the output current shown on the LCP with the measured motor current.
- Display the thermal drive load on the LCP and monitor the value. When running above the frequency converter continuous current rating, the counter increases. When running below the frequency converter continuous current rating, the counter decreases.

WARNING/ALARM 10, Motor overload temperature

According to the electronic thermal protection (ETR), the motor is too hot. Select whether the frequency converter issues a warning or an alarm when the counter reaches 100% in *1-90 Motor Thermal Protection*. The fault occurs when the motor runs with more than 100% overload for too long.

Troubleshooting

- Check for motor overheating.
- Check if the motor is mechanically overloaded.
- Check that the motor current set in *1-24 Motor Current* is correct.

- Ensure that the motor data in *parameters 1-20 to 1-25* are set correctly.
- If an external fan is in use, check that it is selected in *1-91 Motor External Fan*.
- Running AMA in *parameter 1-29 Automatic Motor Adaptation (AMA)* tunes the frequency converter to the motor more accurately and reduces thermal loading.

WARNING/ALARM 11, Motor thermistor overtemp

The thermistor may be disconnected. Select whether the frequency converter issues a warning or an alarm in *1-90 Motor Thermal Protection*.

Troubleshooting

- Check for motor overheating.
- Check if the motor is mechanically overloaded.
- Check that the thermistor is connected correctly between either terminal 53 or 54 (analog voltage input) and terminal 50 (+10 V supply). Also check that the terminal switch for 53 or 54 is set for voltage. Check that *1-93 Thermistor Source* is set to terminal 53 or 54.
- When using digital inputs 18 or 19, check that the thermistor is connected correctly between either terminal 18 or 19 (digital input PNP only) and terminal 50.
- If a KTY sensor is used, check for correct connection between terminals 54 and 55
- If using a thermal switch or thermistor, check that the programming of *1-93 Thermistor Source* matches sensor wiring.
- If using a KTY Sensor, check the programming of *1-95 KTY Sensor Type*, *1-96 KTY Thermistor Resource* and *1-97 KTY Threshold level* match sensor wiring.

WARNING/ALARM 12, Torque limit

The torque has exceeded the value in *4-16 Torque Limit Motor Mode* or the value in *4-17 Torque Limit Generator Mode*. *14-25 Trip Delay at Torque Limit* can change this warning from a warning-only condition to a warning followed by an alarm.

Troubleshooting

- If the motor torque limit is exceeded during ramp up, extend the ramp-up time.
- If the generator torque limit is exceeded during ramp-down, extend the ramp down time.
- If torque limit occurs while running, increase the torque limit. Make sure that the system can operate safely at a higher torque.
- Check the application for excessive current draw on the motor.

WARNING/ALARM 13, Over current

The inverter peak current limit (approximately 200% of the rated current) is exceeded. The warning lasts approximately 1.5 s, then the frequency converter trips and issues an alarm. Shock loading or quick acceleration with high inertia loads can cause this fault. If the acceleration during ramp-up is quick, the fault can also appear after kinetic back-up.

If extended mechanical brake control is selected, a trip can be reset externally.

Troubleshooting

- Remove the power and check if the motor shaft can be turned.
- Check that the motor size matches the frequency converter.
- Check that the motor data is correct in *parameters 1-20 to 1-25*.

ALARM 14, Earth (ground) fault

There is current from the output phases to ground, either in the cable between the frequency converter and the motor, or in the motor itself.

Troubleshooting

- Remove the power to the frequency converter and repair the ground fault.
- Check for ground faults in the motor by measuring the resistance to the ground of the motor cables and the motor with a megohmmeter.
- Perform a current sensor test.

ALARM 15, Hardware mismatch

A fitted option is not operational with the present control board hardware or software.

Record the value of the following parameters and contact Danfoss:

- *15-40 FC Type*
- *15-41 Power Section*
- *15-42 Voltage*
- *15-43 Software Version*
- *15-45 Actual Typecode String*
- *15-49 SW ID Control Card*
- *15-50 SW ID Power Card*
- *15-60 Option Mounted*
- *15-61 Option SW Version* (for each option slot)

ALARM 16, Short circuit

There is short-circuiting in the motor or motor wiring.

Troubleshooting

- Remove the power to the frequency converter and repair the short-circuit.

WARNING/ALARM 17, Control word timeout

There is no communication with the frequency converter.

The warning is only active when *8-04 Control Timeout Function* is not set to [0] Off.

If *8-04 Control Timeout Function* is set to [2] Stop and [26] Trip, a warning appears and the frequency converter ramps down until it trips and then displays an alarm.

Troubleshooting:

- Check the connections on the serial communication cable.
- Increase *8-03 Control Timeout Time*
- Check the operation of the communication equipment.
- Verify a proper installation based on EMC requirements.

WARNING 23, Internal fan fault

The fan warning function is an extra protective function that checks if the fan is running/mounted. The fan warning can be disabled in *14-53 Fan Monitor ([0] Disabled)*.

Troubleshooting

- Check the fan resistance.
- Check the soft charge fuses.

WARNING 24, External fan fault

The fan warning function is an extra protective function that checks if the fan is running/mounted. The fan warning can be disabled in *14-53 Fan Monitor ([0] Disabled)*.

Troubleshooting

- Check the fan resistance.
- Check the soft charge fuses.

WARNING 25, Brake resistor short circuit

The brake resistor is monitored during operation. If a short-circuit occurs, the brake function is disabled and the warning appears. The frequency converter is still operational, but without the brake function.

Troubleshooting

- Remove the power to the frequency converter and replace the brake resistor (see *2-15 Brake Check*).

WARNING/ALARM 26, Brake resistor power limit

The power transmitted to the brake resistor is calculated as a mean value over the last 120 s of run time. The calculation is based on the intermediate circuit voltage and the brake resistance value set in *2-16 AC brake Max. Current*. The warning is active when the dissipated braking is >90% of the brake resistance power. If [2] Trip is selected in *2-13 Brake Power Monitoring*, the frequency converter trips when the dissipated braking power reaches 100%.

⚠ WARNING

If the brake transistor is short-circuited, there is a risk of substantial power being transmitted to the brake resistor.

WARNING/ALARM 27, Brake chopper fault

The brake transistor is monitored during operation. If a short-circuit occurs, the brake function is disabled and a warning is issued. The frequency converter is still operational, but since the brake transistor has short-circuited, substantial power is transmitted to the brake resistor, even if it is inactive.

Remove the power to the frequency converter and remove the brake resistor.

This alarm/warning could also occur if the brake resistor overheats. Terminals 104 and 106 are available as brake resistors Klixon inputs.

WARNING/ALARM 28, Brake check failed

The brake resistor is not connected or not working. Check *2-15 Brake Check*.

ALARM 29, Heat Sink temp

The maximum temperature of the heat sink has been exceeded. The temperature fault resets when the temperature falls below a defined heat sink temperature. The trip and reset points vary based on the frequency converter power size.

Troubleshooting

Check for the following conditions.

- Ambient temperature too high.
- Motor cables too long.
- Incorrect airflow clearance above and below the frequency converter.
- Blocked airflow around the frequency converter.
- Damaged heat sink fan.
- Dirty heat sink.

For D, E, and F enclosures, this alarm is based on the temperature measured by the heat sink sensor mounted inside the IGBT modules. For the F enclosures, the thermal sensor in the rectifier module can also cause this alarm.

Troubleshooting

- Check the fan resistance.
- Check the soft charge fuses.
- Check the IGBT thermal sensor.

ALARM 30, Motor phase U missing

Motor phase U between the frequency converter and the motor is missing.

Troubleshooting

- Remove the power from the frequency converter and check motor phase U.

ALARM 31, Motor phase V missing

Motor phase V between the frequency converter and the motor is missing.

Troubleshooting

- Remove the power from the frequency converter and check motor phase V.

ALARM 32, Motor phase W missing

Motor phase W between the frequency converter and the motor is missing.

Troubleshooting

- Remove the power from the frequency converter and check motor phase W.

ALARM 33, Inrush fault

Too many power-ups have occurred within a short time period.

Troubleshooting

- Let the unit cool to operating temperature.

WARNING/ALARM 34, Fieldbus communication fault

The fieldbus on the communication option card is not working.

WARNING/ALARM 35, Option fault

This warning is active if the output frequency has reached the high limit (set in 4-53 *Warning Speed High*) or low limit (set in 4-52 *Warning Speed Low*). In *Process Control, Closed Loop (1-00 Configuration Mode)* this warning is displayed.

WARNING/ALARM 36, Mains failure

This warning/alarm is only active if the supply voltage to the frequency converter is lost and 14-10 *Mains Failure* is not set to [0] *No Function*. Check the fuses to the frequency converter and mains supply to the unit.

ALARM 38, Internal fault

When an internal fault occurs, a code number defined in Table 8.4 is displayed.

Troubleshooting

- Cycle the power.
- Check that the option is properly installed.
- Check for loose or missing wiring.

It may be necessary to contact Danfoss Service or the supplier. Note the code number for further troubleshooting directions.

Number	Text
0	The serial port cannot be initialised. Contact your Danfoss supplier or Danfoss Service.
256–258	The power EEPROM data is defective or too old.
512	The control board EEPROM data is defective or too old.
513	Communication time-out reading EEPROM data
514	Communication time-out reading EEPROM data
515	Application-oriented control cannot recognise the EEPROM data.
516	Cannot write to the EEPROM because a write command is in progress.
517	The write command is under time-out.
518	Failure in the EEPROM.
519	Missing or invalid barcode data in EEPROM.
783	Parameter value outside of minimum/maximum limits.

Number	Text
1024–1279	A CAN telegram could not be sent.
1281	Digital signal processor flash time-out.
1282	Power micro software version mismatch.
1283	Power EEPROM data version mismatch.
1284	Cannot read digital signal processor software version.
1299	The option software in slot A is too old.
1300	The option software in slot B is too old.
1301	The option software in slot C0 is too old.
1302	The option software in slot C1 is too old.
1315	The option software in slot A is not supported (not allowed).
1316	The option software in slot B is not supported (not allowed).
1317	The option software in slot C0 is not supported (not allowed).
1318	The option software in slot C1 is not supported (not allowed).
1379	Option A did not respond when calculating the platform version
1380	Option B did not respond when calculating the platform version.
1381	Option C0 did not respond when calculating the platform version.
1382	Option C1 did not respond when calculating the platform version.
1536	An exception in the application-oriented control is registered. The debug information is written on the LCP.
1792	DSP Watch Dog is active. Debugging of power part data, motor-oriented control data not transferred correctly.
2049	Power data restarted.
2064–2072	H081x: Option in slot x has restarted.
2080–2088	H082x: Option in slot x has issued a power-up wait.
2096–2104	H983x: Option in slot x has issued a legal power-up wait.
2304	Could not read any data from the power EEPROM.
2305	Missing software version from the power unit.
2314	Missing power unit data from the power unit.
2315	Missing software version from the power unit.
2316	Missing lo_statepage from the power unit.
2324	The power card configuration is determined to be incorrect at power-up.
2325	A power card has stopped communicating while mains power is applied.
2326	The power card configuration is determined to be incorrect after the delay for power cards to register.
2327	Too many power card locations have been registered as present.
2330	The power size information between the power cards does not match.

Number	Text
2561	No communication from DSP to ATACD.
2562	No communication from ATACD to DSP (state running).
2816	Stack overflow control board module
2817	Scheduler slow tasks
2818	Fast tasks
2819	Parameter thread
2820	LCP stack overflow
2821	Serial port overflow
2822	USB port overflow
2836	cfListMempool is too small.
3072–5122	The parameter value is outside its limits.
5123	Option in slot A: Hardware incompatible with the control board hardware.
5124	Option in slot B: Hardware incompatible with the control board hardware.
5125	Option in slot C0: Hardware incompatible with the control board hardware.
5126	Option in slot C1: Hardware incompatible with the control board hardware.
5376–6231	Out of memory

Table 8.4 Internal Fault, Code Numbers

ALARM 39, Heat sink sensor

No feedback from the heat sink temperature sensor.

The signal from the IGBT thermal sensor is not available on the power card. The problem could be on the power card, on the gate drive card, or the ribbon cable between the power card and gate drive card.

WARNING 40, Overload of digital output terminal 27

Check the load connected to terminal 27 or remove the short-circuit connection. Check *5-00 Digital I/O Mode* and *5-01 Terminal 27 Mode*.

WARNING 41, Overload of digital output terminal 29

Check the load connected to terminal 29 or remove the short-circuit connection. Check *5-00 Digital I/O Mode* and *5-02 Terminal 29 Mode*.

WARNING 42, Overload of digital output on X30/6 or overload of digital output on X30/7

For X30/6, check the load connected to X30/6 or remove the short-circuit connection. Check *5-32 Term X30/6 Digi Out (MCB 101)*.

For X30/7, check the load connected to X30/7 or remove the short-circuit connection. Check *5-33 Term X30/7 Digi Out (MCB 101)*.

ALARM 46, Power card supply

The supply on the power card is out of range.

There are 3 power supplies generated by the switch mode power supply (SMPS) on the power card: 24 V, 5 V, and ± 18 V. When powered with 24 V DC with the MCB 107 option, only the 24 V and 5 V supplies are monitored. When

powered with 3-phase mains voltage, all 3 supplies are monitored.

WARNING 47, 24 V supply low

The 24 V DC is measured on the control card. This alarm arises when the detected voltage of terminal 12 is <18 V.

Troubleshooting

- Check for a defective control card.

WARNING 48, 1.8 V supply low

The 1.8 V DC supply used on the control card is outside of the allowable limits. The power supply is measured on the control card. Check for a defective control card. If an option card is present, check for overvoltage.

WARNING 49, Speed limit

When the speed is outside of the specified range in *parameter 4-11 Motor Speed Low Limit [RPM]* and *parameter 4-13 Motor Speed High Limit [RPM]*, the frequency converter shows a warning. When the speed is below the specified limit in *1-86 Trip Speed Low [RPM]* (except when starting or stopping), the frequency converter trips.

ALARM 50, AMA calibration failed

Contact the Danfoss supplier or Danfoss Service.

ALARM 51, AMA check U_{nom} and I_{nom}

The settings for motor voltage, motor current and motor power are wrong. Check the settings in *parameters 1-20* to *1-25*.

ALARM 52, AMA low I_{nom}

The motor current is too low. Check the settings.

ALARM 53, AMA motor too big

The motor is too big for the AMA to operate.

ALARM 54, AMA motor too small

The motor is too small for the AMA to operate.

ALARM 55, AMA parameter out of range

The parameter values of the motor are outside of the acceptable range. AMA cannot run.

ALARM 56, AMA interrupted by user

The user has interrupted the AMA.

ALARM 57, AMA internal fault

Continue to restart the AMA, until the AMA is carried out.

NOTICE

Repeated runs may heat the motor to a level where the resistance R_s and R_r are increased. In most cases, however, this behaviour is not critical.

ALARM 58, AMA Internal fault

Contact your Danfoss supplier.

WARNING 59, Current limit

The current is higher than the value in *4-18 Current Limit*. Ensure that motor data in *parameters 1–20* to *1–25* are set correctly. Increase the current limit if necessary. Ensure that the system can operate safely at a higher limit.

WARNING 60, External interlock

External interlock has been activated. To resume normal operation, apply 24 V DC to the terminal programmed for external interlock and reset the frequency converter (via serial communication, digital I/O, or by pressing [Reset]).

WARNING 62, Output frequency at maximum limit

The output frequency is higher than the value set in *4-19 Max Output Frequency*.

ALARM 64, Voltage Limit

The load and speed combination demands a motor voltage higher than the actual DC-link voltage.

WARNING/ALARM 65, Control card over temperature

The cut-out temperature of the control card is 80 °C.

Troubleshooting

- Check that the ambient operating temperature is within the limits.
- Check for clogged filters.
- Check the fan operation.
- Check the control card.

WARNING 66, Heat sink temperature low

The frequency converter is too cold to operate. This warning is based on the temperature sensor in the IGBT module.

Increase the ambient temperature of the unit. Also, a trickle amount of current can be supplied to the frequency converter whenever the motor is stopped by setting *2-00 DC Hold/Preheat Current* at 5% and *1-80 Function at Stop*.

Troubleshooting

The heat sink temperature measured as 0 °C could indicate that the temperature sensor is defective, causing the fan speed to increase to the maximum. This warning results if the sensor wire between the IGBT and the gate drive card is disconnected. Also, check the IGBT thermal sensor.

ALARM 67, Option module configuration has changed

One or more options have either been added or removed since the last power-down. Check that the configuration change is intentional and reset the unit.

ALARM 68, Safe Stop activated

STO has been activated. To resume normal operation, apply 24 V DC to terminal 37, then send a reset signal (via bus, digital I/O, or by pressing [Reset]).

ALARM 69, Power card temperature

The temperature sensor on the power card is either too hot or too cold.

Troubleshooting

- Check the operation of the door fans.
- Check that the filters for the door fans are not blocked.
- Check that the gland plate is properly installed on IP21/IP54 (NEMA 1/12) frequency converters.

ALARM 70, Illegal FC configuration

The control card and power card are incompatible. To check compatibility, contact your Danfoss supplier with the type code of the unit from the nameplate and the part numbers of the cards.

ALARM 72, Dangerous failure

STO with trip lock. Unexpected signal levels on safe stop and digital input from the VLT® PTC Thermistor Card MCB 112.

WARNING 73, Safe Stop auto restart

Safe stopped. With automatic restart enabled, the motor could start when the fault is cleared.

WARNING 76, Power unit setup

The required number of power units does not match the detected number of active power units.

WARNING 77, Reduced power mode

The frequency converter is operating in reduced power mode (less than the allowed number of inverter sections). This warning is generated on power cycle when the frequency converter is set to run with fewer inverters and remains on.

ALARM 79, Illegal power section configuration

The scaling card has an incorrect part number or is not installed. The MK102 connector on the power card could not be installed.

ALARM 80, Drive initialised to default value

Parameter settings are initialised to default settings after a manual reset. To clear the alarm, reset the unit.

ALARM 91, Analog input 54 wrong settings

Switch S202 has to be set in position OFF (voltage input) when a KTY sensor is connected to analog input terminal 54.

ALARM 92, No flow

A no-flow condition has been detected in the system. *parameter 22-23 No-Flow Function* is set for alarm.

Troubleshooting

- Troubleshoot the system and reset the frequency converter after the fault has been cleared.

ALARM 93, Dry pump

A no-flow condition in the system with the frequency converter operating at high speed may indicate a dry pump. *parameter 22-26 Dry Pump Function* is set for alarm. Troubleshoot the system and reset the frequency converter after the fault has been cleared.

ALARM 94, End of curve

Feedback is lower than the set point. This may indicate leakage in the system. *parameter 22-50 End of Curve Function* is set for alarm.

Troubleshooting

- Troubleshoot the system and reset the frequency converter after the fault has been cleared.

ALARM 95, Broken belt

Torque is below the torque level set for no load, indicating a broken belt. *22-60 Broken Belt Function* is set for alarm.

Troubleshooting

- Troubleshoot the system and reset the frequency converter after the fault has been cleared.

ALARM 96, Start delayed

Motor start has been delayed due to short-cycle protection. *22-76 Interval between Starts* is enabled.

Troubleshooting

- Troubleshoot the system and reset the frequency converter after the fault has been cleared.

WARNING 97, Stop delayed

Stopping the motor has been delayed due to short -cycle protection. *22-76 Interval between Starts* is enabled.

Troubleshooting

- Troubleshoot the system and reset the frequency converter after the fault has been cleared.

WARNING 98, Clock fault

Time is not set or the RTC clock has failed.

Troubleshooting

- Reset the clock in *0-70 Date and Time*.

ALARM 220, Overload trip

Motor overload has tripped. Indicates excess motor load.

Troubleshooting

- Check motor and driven load.
- To reset, press [Off Reset].
- Then, to restart the system press [Auto on] or [Hand on].

ALARM 243, Brake IGBT

This alarm is only for enclosure size F frequency converters. It is equivalent to Alarm 27. The report value in the alarm log indicates which power module generated the alarm:

- 1 = Left most inverter module.
- 2 = Middle inverter module in enclosure sizes F12 or F3.
- 2 = Right inverter module in enclosure sizes F10 or F11.
- 2 = Second frequency converter from the left inverter module in enclosure size F14.
- 3 = Right inverter module in enclosure sizes F12 or F13.
- 3 = Third from the left inverter module in enclosure size F14.
- 4 = Far right inverter module in enclosure size F14.
- 5 = Rectifier module.
- 6 = Right rectifier module in enclosure size F14.

ALARM 244, Heat Sink temperature

This alarm is only for enclosure type F frequency converters. It is equivalent to Alarm 29. The report value in the alarm log indicates which power module generated the alarm:

- 1 = Left most inverter module.
- 2 = Middle inverter module in enclosure size F12 or F3.
- 2 = Right inverter module in enclosure size F10 or F11.
- 2 = Second frequency converter from the left inverter module in enclosure size F14.
- 3 = Right inverter module in enclosure sizes F12 or F13.
- 3 = Third from the left inverter module in enclosure size F14.
- 4 = Far right inverter module in enclosure sizes F14.
- 5 = Rectifier module.
- 6 = Right rectifier module in enclosure sizes F14.

ALARM 245, Heat Sink sensor

This alarm is only for enclosure size F frequency converters. It is equivalent to Alarm 39. The report value in the alarm log indicates which power module generated the alarm:

- 1 = Left most inverter module.
- 2 = Middle inverter module in enclosure sizes F12 or F13.
- 2 = Right inverter module in enclosure sizes F10 or F11.
- 2 = Second frequency converter from the left inverter module in enclosure size F14.
- 3 = Right inverter module in enclosure sizes F12 or F13.
- 3 = Third from the left inverter module in enclosure size F14.
- 4 = Far right inverter module in enclosure size F14.
- 5 = Rectifier module.
- 6 = Right rectifier module in enclosure size F14.

ALARM 246, Power card supply

This alarm is only for enclosure size F frequency converters. It is equivalent to Alarm 46. The report value in the alarm log indicates which power module generated the alarm:

- 1 = Left most inverter module.
- 2 = Middle inverter module in enclosure sizes F12 or F13.
- 2 = Right inverter module in enclosure sizes F10 or F11.

- 2 = Second frequency converter from the left inverter module in enclosure size F14.
- 3 = Right inverter module in enclosure sizes F12 or F13.
- 3 = Third from the left inverter module in enclosure size F14.
- 4 = Far right inverter module in enclosure size F14.
- 5 = Rectifier module.
- 6 = Right rectifier module in enclosure size F14.

ALARM 247, Power card temperature

This alarm is only for enclosure size F frequency converters. It is equivalent to Alarm 69. The report value in the alarm log indicates which power module generated the alarm:

- 1 = Left most inverter module.
- 2 = Middle inverter module in enclosure sizes F12 or F13.
- 2 = Right inverter module in enclosure sizes F10 or F11.
- 2 = Second frequency converter from the left inverter module in enclosure size F14.
- 3 = Right inverter module in enclosure sizes F12 or F13.
- 3 = Third from the left inverter module in enclosure size F14.
- 4 = Far right inverter module in enclosure size F14.
- 5 = Rectifier module.
- 6 = Right rectifier module in enclosure size F14.

ALARM 248, Illegal power section configuration

This alarm is only for enclosure size F frequency converters. It is equivalent to Alarm 79. The report value in the alarm log indicates which power module generated the alarm:

- 1 = Left most inverter module.
- 2 = Middle inverter module in enclosure sizes F12 or F13.
- 2 = Right inverter module in enclosure sizes F10 or F11.
- 2 = Second frequency converter from the left inverter module in enclosure size F14.
- 3 = Right inverter module in enclosure sizes F12 or F13.
- 3 = Third from the left inverter module in enclosure sizes F14.
- 4 = Far right inverter module in enclosure sizes F14.
- 5 = Rectifier module.
- 6 = Right rectifier module in enclosure size F14.

WARNING 250, New spare part

A component in the frequency converter has been replaced.

Troubleshooting

- Reset the frequency converter for normal operation.

WARNING 251, New typecode

The power card or other components have been replaced and the typecode changed.

Troubleshooting

- Reset to remove the warning and resume normal operation.

Index

A

Abbreviations..... 5

Access to control terminal..... 42

Airflow..... 22

Alarm/warning code list..... 111

Alarms and Warnings..... 109

AMA..... 48, 57, 114, 117

Analog input..... 99, 113

Analog output..... 99

Analog signal..... 113

Automatic motor adaptation (AMA)..... 48

B

Back cooling..... 22

Braje

 Brake control..... 114

Brake

 cable..... 37

 control, mechanical..... 49

 resistor..... 113

 resistor temperature switch..... 41

Braking..... 115

Branch circuit protection..... 38

C

Cable length and cross-section..... 30, 98

Cable, motor..... 36

Cabling..... 28

Changing a group of numeric data values..... 56

Changing a text value..... 56

Changing data..... 56

Changing of data value..... 57

Closed loop..... 116

Coasting..... 54

Communication option..... 116

Control cable..... 45, 47

Control card

 Control card..... 113

Control card performance..... 101

Control card, 10 V DC output..... 101

Control card, 24 V DC output..... 100

Control card, RS-485 serial communication..... 100

Control card, USB serial communication..... 101

Control characteristic..... 101

Control terminal..... 42

Conventions..... 6

Cooling..... 22

Current rating..... 113

D

DC link..... 113

Default setting..... 57, 93

Delivery..... 9

Digital input..... 98, 114

Digital output..... 100

Display Line 1.3 Small, 0-22..... 69

Display Line 3 Large, 0-24..... 69

Drive Closed Loop, 20-**..... 82

Dry pump function..... 85

Duct cooling..... 22

E

ELCB relay..... 35

Electrical installation..... 42, 45

Enclosure size F panel options..... 26

External fan supply..... 38

External temperature monitoring..... 27

F

Feedback..... 117, 118

Fieldbus connection..... 41

Fuse..... 38, 116

Fuse tables..... 38

Fuse-protected terminals, 30 Amp..... 27

Fusing..... 28

G

General considerations..... 15

General Settings, 1-0*..... 70

Gland/conduit entry, IP21 (NEMA 1) and IP54 (NEMA12)..... 23

GLCP..... 57

Graphical display..... 51

Grounding..... 35

H

Heat sink..... 117

High voltage..... 7

How to connect a PC to the frequency converter..... 58

I

Indexed parameter..... 57

Indicator lights (LEDs)..... 52

Initialisation..... 57

Input polarity of control terminals..... 47

Input terminal..... 113

Inspection on receipt..... 9

Installation

 Installation, mechanical..... 15

 Installation, electrical..... 45

Insulation resistance monitor (IRM)..... 26

Intermediate circuit..... 113

IT mains..... 35

L

Language package..... 65

LCP..... 54, 57

LCP 102..... 51

Leakage current..... 7

LEDs..... 51

Local reference..... 72

Low power detection..... 84

Low speed detection..... 84

M

Main menu..... 61

Main Menu mode..... 53, 64

Main reactance..... 70

Mains connection..... 37

Mains supply (L1-1, L2-1, L3-1, L1-2, L2-2, L3-2)..... 98

Manual motor starter..... 26

Mechanical brake control..... 49

Mechanical dimensions..... 14

Mechanical Dimensions..... 11

Mechanical installation..... 15

Motor

 cable..... 36

 current..... 117

 data..... 114, 117

 nameplate..... 48

 power..... 117

 thermal protection..... 50

Motor output..... 98

Motor protection..... 101

N

NAMUR..... 26

NLCP..... 54

O

Operation/display, 0-**..... 65

Output current..... 113

Output performance (U, V, W)..... 98

Overcurrent protection..... 38

P

Parallel connection of motors..... 49

Parameter Options..... 93

Parameter selection..... 64

Parameter set-up..... 60

PC software tools..... 59

Phase loss..... 113

Planning the installation site..... 9

Potentiometer reference..... 44

Power connection..... 28

Profibus DP-V1..... 59

Programming..... 113

Protection and features..... 101

Pulse input..... 99

Pulse start/stop..... 43

Q

Q1 My Personal Menu..... 61

Q2 Quick Setup..... 61

Q3 Function Set-ups..... 62

Q5 Changes Made..... 64

Q6 Loggings..... 64

Qualified personnel..... 7

Quick menu..... 61

Quick Menu..... 53, 61

Quick Menu mode..... 53

Quick Transfer of Parameter Settings when Using GLCP..... 57

R

RCD (Residual current device)..... 26

Receiving the frequency converter..... 9

Reference Limits, 3-0*..... 71

Relay output..... 100

Reset..... 54, 113, 114, 118

RFI switch..... 35

RS-485 bus connection..... 58

S

Safe Torque Off..... 8

Screened cable.....	36
Screened/armoured.....	47
Screening of cables.....	30
Serial communication.....	101
Short circuit.....	114
Short-circuit protection.....	38
Sine-wave filter.....	30
Space.....	15
Space heaters and thermostat.....	26
Speed up/down.....	43
Start/stop.....	43
Stator leakage reactance.....	70
Status.....	53
Status messages.....	51
STO.....	8
Supply voltage.....	116
Surrounding.....	101
Switches S201, S202 and S801.....	47
Switching frequency.....	30

T

Terminal 54.....	118
Terminals, fuse-protected, 30 ampere.....	27
Thermal motor protection.....	114
Thermal protection.....	5
Thermistor.....	114
Tightening torque.....	35
Timed Actions, 23-0*.....	89
Torque.....	35, 114
Torque characteristic.....	98

U

Unintended motor rotation.....	8
Unintended start.....	7
Unpacking.....	9

V

Voltage imbalance.....	113
Voltage level.....	99
Voltage reference via a potentiometer.....	44
VVC+.....	6

W

Water Application Functions.....	91
Windmilling.....	8
Wire access.....	15



www.danfoss.com/drives

.....
Danfoss can accept no responsibility for possible errors in catalogues, brochures and other printed material. Danfoss reserves the right to alter its products without notice. This also applies to products already on order provided that such alterations can be made without subsequential changes being necessary in specifications already agreed. All trademarks in this material are property of the respective companies. Danfoss and the Danfoss logotype are trademarks of Danfoss A/S. All rights reserved.
.....

Danfoss A/S
Ulsnaes 1
DK-6300 Graasten
www.danfoss.com/drives

