



# Instruction Manual, 110–400 kW D-Frame

VLT<sup>®</sup> AQUA Drive FC 200



## Safety

### Safety

#### **⚠ WARNING**

##### **HIGH VOLTAGE!**

Adjustable frequency drives contain high voltage when connected to AC line power. Installation, startup, and maintenance should be performed by qualified personnel only. Failure to perform installation, startup, and maintenance by qualified personnel could result in death or serious injury.

##### **High Voltage**

Adjustable frequency drives are connected to hazardous AC line voltage. Extreme care should be taken to protect against shock. Only trained personnel familiar with electronic equipment should install, start, or maintain this equipment.

#### **⚠ WARNING**

##### **UNINTENDED START!**

When the adjustable frequency drive is connected to AC line power, the motor may start at any time. The adjustable frequency drive, motor, and any driven equipment must be in operational readiness. Failure to be in operational readiness when the adjustable frequency drive is connected to AC line power could result in death, serious injury, equipment, or property damage.

##### **Unintended Start**

When the adjustable frequency drive is connected to AC line power, the motor may be started with an external switch, a serial bus command, an input reference signal, or a cleared fault condition. Use appropriate caution to guard against an unintended start.

#### **⚠ WARNING**

##### **DISCHARGE TIME!**

Adjustable frequency drives contain DC link capacitors that can remain charged even when the adjustable frequency drive is not powered. To avoid electrical hazards, disconnect AC line power, any permanent magnet type motors, and any remote DC link power supplies, including battery backups, UPS and DC link connections to other adjustable frequency drives. Wait for the capacitors to fully discharge before performing any service or repair work. The wait time required is listed in the *Discharge Time* table. Failure to wait for the specified period of time after power has been removed to do service or repair could result in death or serious injury.

Voltage [V]	Power range [kW]	Minimum waiting time [min]
3x400	90–250	20
3x400	110–315	20
3x500	110–315	20
3x500	132–355	20
3x525	75–250	20
3x525	90–315	20
3x690	90–250	20
3x690	110–315	20

Discharge Time

### Approvals



Table 1.2



## Contents

<b>1 Introduction</b>	2-1
1.1 Product Overview	2-1
1.1.2 Extended Options Cabinets	2-2
1.2 Purpose of the Manual	2-3
1.3 Additional Resources	2-3
1.4 Product Overview	2-3
1.5 Internal Controller Functions	2-4
1.6 Frame Sizes and Power Ratings	2-5
<b>2 Installation</b>	3-1
2.1 Planning the Installation Site	3-1
2.2 Pre-Installation Check List	3-1
2.3 Mechanical Installation	3-1
2.3.1 Cooling	3-1
2.3.2 Lifting	3-2
2.3.3 Wall Mounting - IP21 (NEMA 1) and IP54 (NEMA 12) Units	3-2
2.4 Electrical Installation	3-3
2.4.1 General Requirements	3-3
2.4.2 Grounding Requirements	3-6
2.4.2.1 Leakage Current (>3.5 mA)	3-6
2.4.2.2 Grounding IP20 Enclosures	3-7
2.4.2.3 Grounding IP21/54 Enclosures	3-7
2.4.3 Motor Connection	3-7
2.4.3.1 Terminal Locations: D1h-D4h	3-8
2.4.3.2 Terminal Locations: D5h-D8h	3-12
2.4.4 Motor Cable	3-21
2.4.5 Motor Rotation Check	3-21
2.4.6 AC Line Input Connection	3-21
2.5 Control Wiring Connection	3-22
2.5.1 Access	3-22
2.5.2 Using Shielded Control Cables	3-22
2.5.3 Grounding of Shielded Control Cables	3-23
2.5.4 Control Terminal Types	3-23
2.5.5 Wiring to Control Terminals	3-24
2.5.6 Control Terminal Functions	3-24
2.6 Serial Communication	3-25
2.7 Optional Equipment	3-25

Contents	VLT® AQUA Drive D-Frame Instruction Manual
2.7.1 Load Share Terminals	3-25
2.7.2 Regeneration Terminals	3-25
2.7.3 Anti-condensation Heater	3-25
2.7.4 Brake Chopper	3-25
2.7.5 line Power Shield	3-25
2.7.6 Line Power Disconnect	3-26
2.7.7 Contactor	3-26
2.7.8 Circuit Breaker	3-26
<b>3 Startup and Commissioning</b>	<b>4-1</b>
3.1 Pre-start	4-1
3.2 Applying Power	4-2
3.3 Basic Operational Programming	4-2
3.4 Local Control Test	4-4
3.5 System startup	4-4
<b>4 User Interface</b>	<b>5-1</b>
4.1 Local Control Panel	5-1
4.1.1 LCP Layout	5-1
4.1.2 Setting LCP Display Values	5-2
4.1.3 Display Menu Keys	5-2
4.1.4 Navigation Keys	5-3
4.1.5 Operation Keys	5-3
4.2 Back Up and Copying Parameter Settings	5-3
4.2.1 Uploading Data to the LCP	5-4
4.2.2 Downloading Data from the LCP	5-4
4.3 Restoring Default Settings	5-4
4.3.1 Recommended Initialization	5-4
4.3.2 Manual Initialization	5-4
<b>5 Programming</b>	<b>6-1</b>
5.1 Introduction	6-1
5.2 Programming Example	6-1
5.3 Control Terminal Programming Examples	6-3
5.4 International/North American Default Parameter Settings	6-3
5.5 Parameter Menu Structure	6-4
5.6 Remote Programming with MCT 10 Set-up Software	6-9
<b>6 Application Examples</b>	<b>7-1</b>
6.1 Introduction	7-1

6.2 Application Examples	7-1
<b>7 Status Messages</b>	<b>8-1</b>
7.1 Status Display	8-1
7.2 Status Message Definitions Table	8-1
<b>8 Warnings and Alarms</b>	<b>9-1</b>
8.1 System Monitoring	9-1
8.2 Warning and Alarm Types	9-1
8.2.1 Warnings	9-1
8.2.2 Alarm Trip	9-1
8.2.3 Alarm Trip Lock	9-1
8.3 Warning and Alarm Displays	9-1
8.4 Warning and Alarm Definitions	9-3
8.5 Fault Messages	9-4
<b>9 Basic Troubleshooting</b>	<b>10-1</b>
9.1 Start Up and Operation	10-1
<b>10 Specifications</b>	<b>11-1</b>
10.1 Power-dependent Specifications	11-1
10.2 General Technical Data	11-4
10.3 Fuse Tables	11-8
10.3.1 Protection	11-8
10.3.2 Fuse Selection	11-8
10.3.3 Short Circuit Current Rating (SCCR)	11-9
10.3.4 Connection Tightening Torques	11-10
<b>12 Index</b>	<b>12-1</b>





# 1 Introduction

## 1.1 Product Overview

### 1.1.1 Interior Views

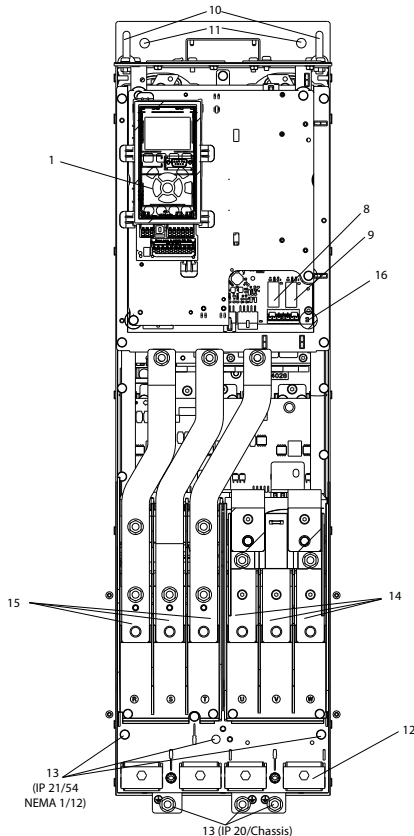

Figure 1.1 D1 Interior Components

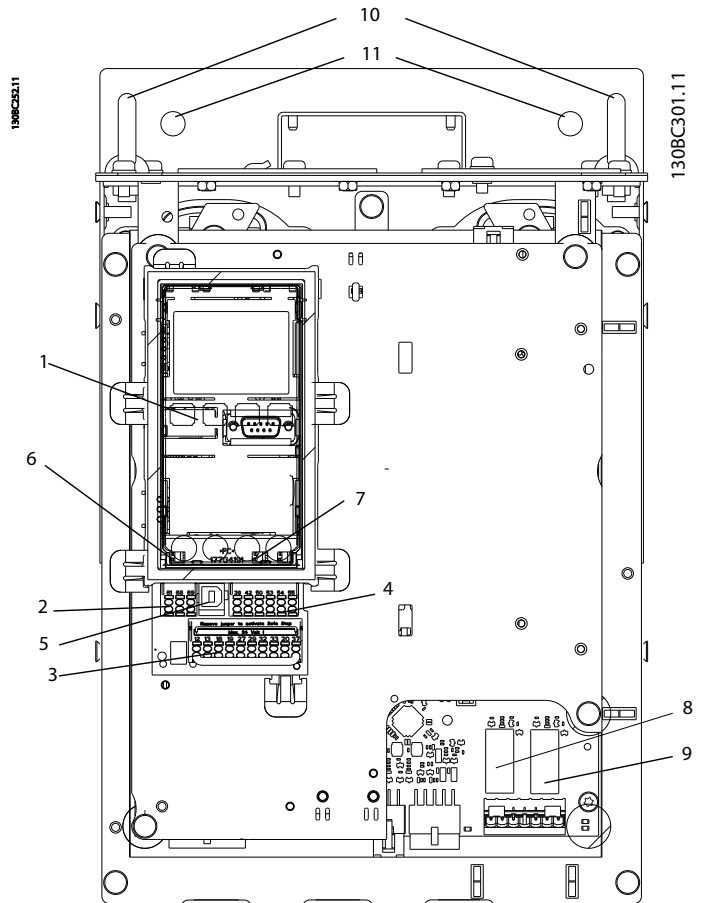

Figure 1.2 Close-up View: LCP and Control Functions

1	LCP (Local Control Panel)	9	Relay 2 (04, 05, 06)
2	RS-485 serial bus connector	10	Lifting ring
3	Digital I/O and 24 V power supply	11	Mounting slot
4	Analog I/O connector	12	Cable clamp (PE)
5	USB connector	13	Ground
6	Serial bus terminal switch	14	Motor output terminals 96 (U), 97 (V), 98 (W)
7	Analog switches (A53), (A54)	15	Line power input terminals 91 (L1), 92 (L2), 93 (L3)
8	Relay 1 (01, 02, 03)	16	TB5 (IP21/54 only). Terminal block for anti-condensation heater

Table 1.1

### NOTE!

For location of TB6 (terminal block for contactor), see 2.4.3.2 Terminal Locations: D5h-D8h.

### 1.1.2 Extended Options Cabinets

If an adjustable frequency drive is ordered with one of the following options, it is supplied with an options cabinet that makes it taller.

- Brake chopper
- Line power disconnect
- Contactor
- Line power disconnect with contactor
- Circuit breaker

Figure 1.3 shows an example of an adjustable frequency drive with an options cabinet. Table 1.2 lists the variants for the adjustable frequency drives that include input options.

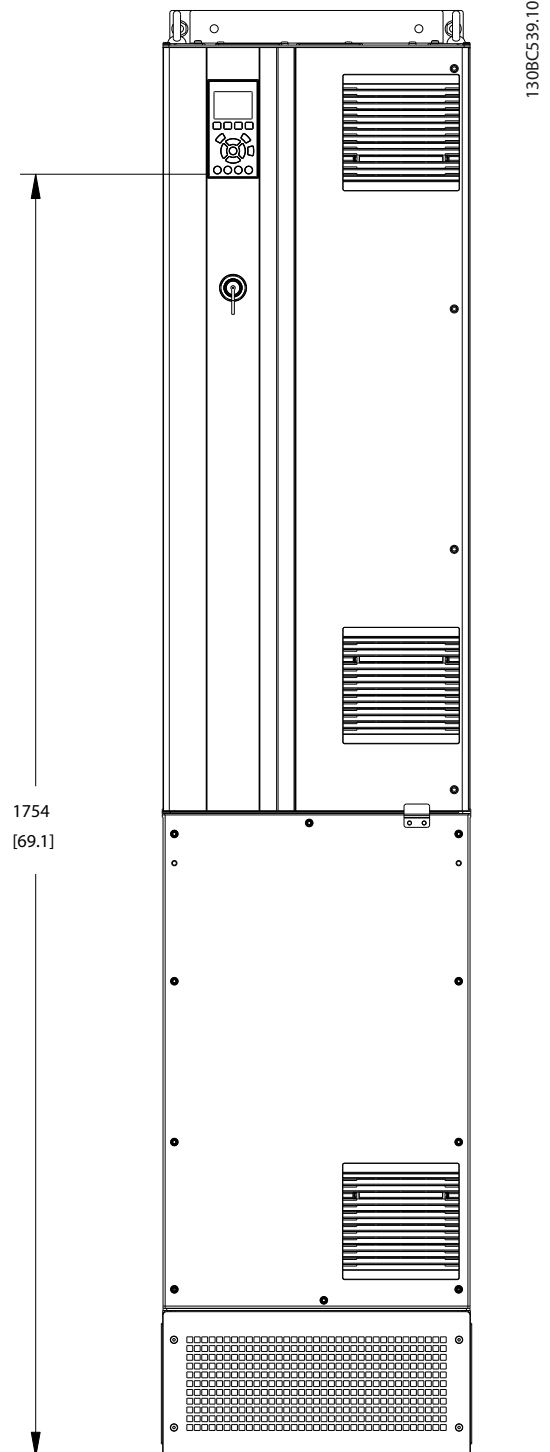

Figure 1.3 D7h Enclosure

Options unit designations	Extension cabinets	Possible options
D5h	D1h enclosure with short extension	Brake, Disconnect
D6h	D1h enclosure with tall extension	Contactors, Contactors with Disconnect, Circuit Breaker
D7h	D2h enclosure with short extension	Brake, Disconnect
D8h	D2h enclosure with tall extension	Contactors, Contactors with Disconnect, Circuit Breaker

Table 1.2

The D7h and D8h adjustable frequency drives (D2h plus options cabinet), include a 7.87 in [200 mm] pedestal for floor mounting.

There is a safety latch on the front cover of the options cabinet. If the adjustable frequency drive is supplied with a line power disconnect or circuit breaker, the safety latch prevents the cabinet door from being opened while the adjustable frequency drive is energized. Before opening the door of the adjustable frequency drive, the disconnect or circuit breaker must be opened (to de-energize the adjustable frequency drive) and the cover of the options cabinet must be removed.

For adjustable frequency drives purchased with a disconnect, contactor or circuit breaker, the nameplate label includes a type code for a replacement that does not include the option. If there is a problem with the adjustable frequency drive, it is replaced independent of the options.

Refer to 2.7 *Optional Equipment* for more detailed descriptions of the input options and other options that may be added to the adjustable frequency drive.

## 1.2 Purpose of the Manual

This manual is intended to provide detailed information for the installation and startup of the adjustable frequency drive. 2 *Installation* provides requirements for mechanical and electrical installation, including input, motor, control and serial communications wiring and control terminal functions. 3 *Startup and Commissioning* provides detailed procedures for startup, basic operational programming, and functional testing. The remaining chapters provide supplementary details. These details include user interface, detailed programming, application examples, startup troubleshooting, and specifications.

## 1.3 Additional Resources

Other resources are available to understand advanced adjustable frequency drive functions and programming.

- The *VLT® Programming Guide* provides greater detail on working with parameters and many application examples.
- The *VLT® Design Guide* is intended to provide detailed capabilities and functionality to design motor control systems.
- Supplementary publications and manuals are available from Danfoss. See <http://www.danfoss.com/BusinessAreas/Drives-Solutions/Documentations/Technical+Documentation.htm> for listings.
- Optional equipment is available that may change some of the procedures described. Reference the instructions supplied with those options for specific requirements. Contact the local Danfoss supplier or visit the Danfoss website: <http://www.danfoss.com/BusinessAreas/DrivesSolutions/Documentations/Technical+Documentation.htm>, for downloads or additional information.

## 1.4 Product Overview

An adjustable frequency drive is an electronic motor controller that converts AC line power input into a variable AC waveform output. The frequency and voltage of the output are regulated to control the motor speed or torque. The adjustable frequency drive can vary the speed of the motor in response to system feedback, such as position sensors on a conveyor belt. The adjustable frequency drive can also regulate the motor by responding to remote commands from external controllers.

In addition, the adjustable frequency drive monitors the system and motor status, issues warnings or alarms for fault conditions, starts and stops the motor, optimizes energy efficiency, and offers many more control, monitoring, and efficiency functions. Operation and monitoring functions are available as status indications to an outside control system or serial communication network.

### 1.5 Internal Controller Functions

Figure 1.4 is a block diagram of the adjustable frequency drive's internal components. See Table 1.3 for their functions.

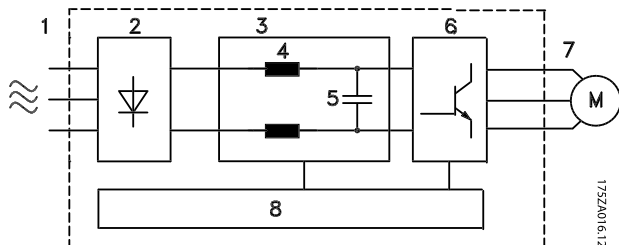

Figure 1.4 Adjustable Frequency Drive Block Diagram

Area	Title	Functions
1	Mains input	<ul style="list-style-type: none"> <li>Three-phase AC line power supply to the adjustable frequency drive</li> </ul>
2	Rectifier	<ul style="list-style-type: none"> <li>The rectifier bridge converts the AC input to DC current to supply inverter power</li> </ul>
3	DC bus	<ul style="list-style-type: none"> <li>Intermediate DC bus circuit handles the DC current</li> </ul>
4	DC reactors	<ul style="list-style-type: none"> <li>Filter the intermediate DC circuit voltage</li> <li>Provide line transient protection</li> <li>Reduce RMS current</li> <li>Raise the power factor reflected back to the line</li> <li>Reduce harmonics on the AC input</li> </ul>
5	Capacitor bank	<ul style="list-style-type: none"> <li>Stores the DC power</li> <li>Provides ride-through protection for short power losses</li> </ul>
6	Inverter	<ul style="list-style-type: none"> <li>Converts the DC into a controlled PWM AC waveform for a controlled variable output to the motor</li> </ul>
7	Output to motor	<ul style="list-style-type: none"> <li>Regulated three-phase output power to the motor</li> </ul>
8	Control circuitry	<ul style="list-style-type: none"> <li>Input power, internal processing, output, and motor current are monitored to provide efficient operation and control</li> <li>User interface and external commands are monitored and performed</li> <li>Status output and control can be provided</li> </ul>

Table 1.3 Adjustable Frequency Drive Internal Components

## 1.6 Frame Sizes and Power Ratings

kW High Overload	75	90	110	132	160	200	250	315	315
kW Normal Overload	90	110	132	160	200	250	315	355	400
400 V		D3h	D3h	D3h	D4h	D4h	D4h		
500 V			D3h	D3h	D3h	D4h	D4h	D4h	
525 V	D3h	D3h	D3h	D4h	D4h	D4h	D4h		
690 V		D3h	D3h	D3h	D4h	D4h	D4h		D4h

**Table 1.4 kW Rated Adjustable Frequency Drives**

HP High Overload	100	125	150	200	250	300	350	350
HP Normal Overload	125	150	200	250	300	350	400	450
460 V		D3h	D3h	D3h	D4h	D4h		D4h
575 V	D3h	D3h	D3h	D4h	D4h	D4h	D4h	

**Table 1.5 HP Rated Adjustable Frequency Drives**



## 2 Installation

### 2.1 Planning the Installation Site

#### NOTE!

Before performing the installation, it is important to plan the installation of the adjustable frequency drive.

Neglecting this may result in extra work during and after installation.

Select the best possible operation site by considering the following (see details on the following pages and the respective Design Guides):

- Ambient operating temperature
- Installation method
- How to cool the unit
- Position of the adjustable frequency drive.
- Cable routing
- Ensure the power source supplies the correct voltage and necessary current.
- Ensure that the motor current rating is within the maximum current from the adjustable frequency drive.
- If the adjustable frequency drive is without built-in fuses, ensure that the external fuses are rated correctly

- Line power
- Adjustable frequency drive
- Motor
- Ensure that adjustable frequency drive output current rating is equal to or greater than motor full load current for peak motor performance
  - Motor size and adjustable frequency drive power must match for proper overload protection
  - If adjustable frequency drive rating is less than motor, full motor output cannot be achieved

Voltage [V]	Altitude restrictions
380–500	At altitudes above 10,000 ft [3 km], contact Danfoss regarding PELV
525–690	At altitudes above 6,600 ft [2 km], contact Danfoss regarding PELV

Table 2.1 Installation in High Altitudes

### 2.2 Pre-Installation Check List

- Before unpacking the adjustable frequency drive, ensure the packaging is intact. If any damage has occurred, immediately contact the shipping company to claim the damage.
- Before unpacking the adjustable frequency drive, locate it as close as possible to the final installation site
- Compare the model number on the nameplate to what was ordered to verify the proper equipment
- Ensure each of the following are rated for the same voltage:

### 2.3 Mechanical Installation

#### 2.3.1 Cooling

- Top and bottom clearance for air cooling must be provided. Generally, 9 in [225 mm] is required.
- Improper mounting can result in overheating and reduced performance.
- Derating for temperatures starting between 45°C (113°F) and 50°C (122°F) and elevation 1,000 m (3,300 ft) above sea level must be considered. See *VLT® Design Guide* for detailed information.

The high power adjustable frequency drives utilize a backchannel cooling concept that removes heatsink cooling air, which carries approximately 90% of the heat out of the back channel of the adjustable frequency drives. The backchannel air can be redirected from the panel or room using one of the kits below.

#### Duct cooling

A backchannel cooling kit is available to direct the heatsink cooling air out of the panel when an IP20/chassis adjustable frequency drives is installed in a Rittal enclosure. Use of this kit reduces the heat in the panel and smaller door fans can be specified on the enclosure.

#### Cooling out the back (top and bottom covers)

The backchannel cooling air can be ventilated out of the room so that the heat from the backchannel is not dissipated into the control room.

A door fan or fans are required on the enclosure to remove the heat not contained in the backchannel of the adjustable frequency drives and any additional losses generated by other components inside the enclosure. The total required air flow must be calculated so that the appropriate fans can be selected.

**Airflow**

The necessary airflow over the heatsink must be ensured. The flow rate is shown in *Table 2.2*.

The fan runs for the following reasons:

- AMA
- DC Hold
- Pre-Mag
- DC Brake
- 60% of nominal current is exceeded
- Specific heatsink temperature exceeded (power size dependent)
- Specific Power Card ambient temperature exceeded (power size-dependent)
- Specific Control Card ambient temperature exceeded

Frame	Door fan/top fan	Heatsink fan
D1h/D3h	102 m <sup>3</sup> /hr (60 CFM)	420 m <sup>3</sup> /hr (250 CFM)
D2h/D4h	204 m <sup>3</sup> /hr (120 CFM)	840 m <sup>3</sup> /hr (500 CFM)

Table 2.2 Airflow

2.3.2 Lifting

Always lift the adjustable frequency drive using the dedicated lifting eyes. Use a bar to avoid bending the lifting holes.

**CAUTION**

The angle from the top of the adjustable frequency drive to the lifting cables should be 60° or greater.

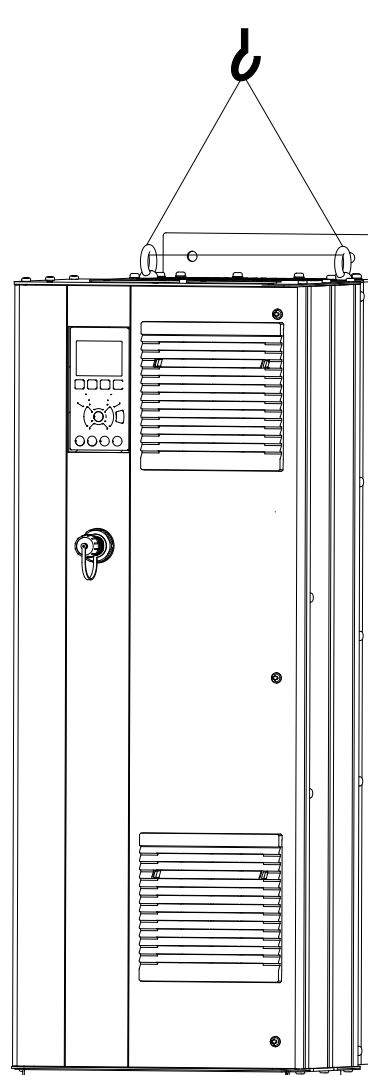

1306/CS/25.10

Figure 2.1 Recommended Lifting Method

2.3.3 Wall Mounting - IP21 (NEMA 1) and IP54 (NEMA 12) Units

Consider the following before selecting the final installation site:

- Clearance space for cooling
- Clearance for opening the door
- Cable entry clearance from the bottom



## 2.4 Electrical Installation

### 2.4.1 General Requirements

This section contains detailed instructions for wiring the adjustable frequency drive. The following tasks are described:

- Wiring the motor to the adjustable frequency drive output terminals
- Wiring the AC mains to the adjustable frequency drive input terminals
- Connecting control and serial communication wiring
- After power has been applied, checking input and motor power; programming control terminals for their intended functions

#### **WARNING**

##### **EQUIPMENT HAZARD!**

Rotating shafts and electrical equipment can be hazardous. All electrical work must conform to national and local electrical codes. It is strongly recommended that installation, startup, and maintenance be performed only by trained and qualified personnel. Failure to follow these guidelines could result in death or serious injury.

#### **CAUTION**

##### **WIRING ISOLATION!**

Run input power, motor wiring and control wiring in three separate metallic conduits or use separated shielded cable for high frequency noise isolation. Failure to isolate power, motor and control wiring could result in less than optimum adjustable frequency drive and associated equipment performance.

2

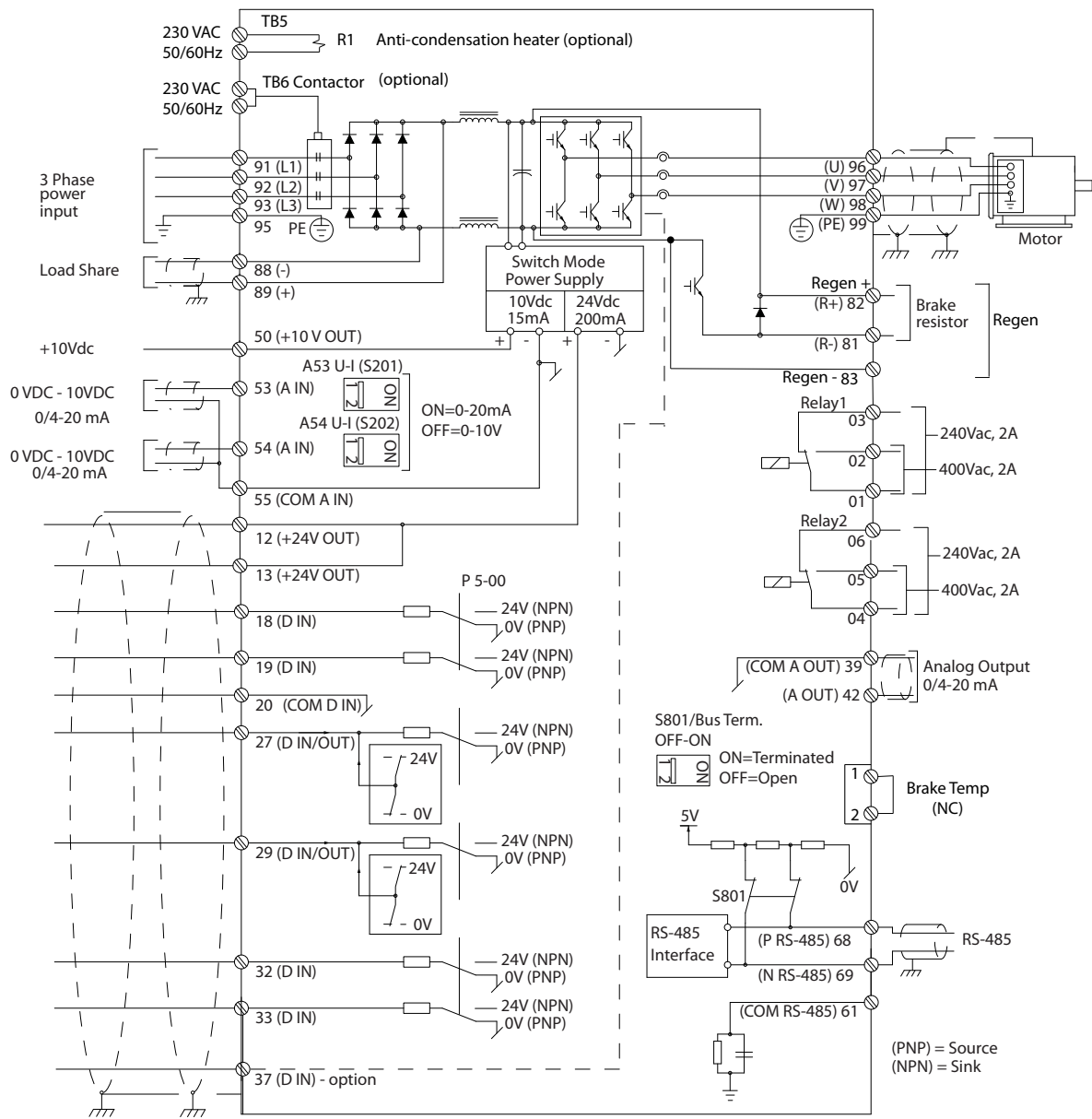

130RC54R.11

Figure 2.2 Interconnect Diagram

**For your safety, comply with the following requirements**

- Electronic controls equipment is connected to hazardous AC line voltage. Extreme care should be taken to protect against electrical hazards when applying power to the unit.
- Run motor cables from multiple adjustable frequency drives multiple adjustable frequency drives separately. Induced voltage from output motor cables run together can charge equipment capacitors even with the equipment turned off and locked out.
- Field wiring terminals are not intended to receive a conductor one size larger.

**Overload and Equipment Protection**

- An electronically activated function within the adjustable frequency drive provides overload protection for the motor. The overload calculates the level of increase to activate timing for the trip (controller output stop) function. The higher the current draw, the quicker the trip response. The overload provides Class 20 motor protection. See *8 Warnings and Alarms* for details on the trip function.
- Because the motor wiring carries high frequency current, it is important that wiring for line power, motor power, and control is run separately. Use metallic conduit or separated shielded wire. See *Figure 2.3*. Failure to isolate power, motor, and control wiring could result in less than optimum equipment performance.
- All adjustable frequency drives must be provided with short-circuit and overcurrent protection. Input fusing is required to provide this protection, see *Figure 2.4*. If not factory supplied, fuses must be provided by the installer as part of installation. See maximum fuse ratings in *10.3.1 Protection*.

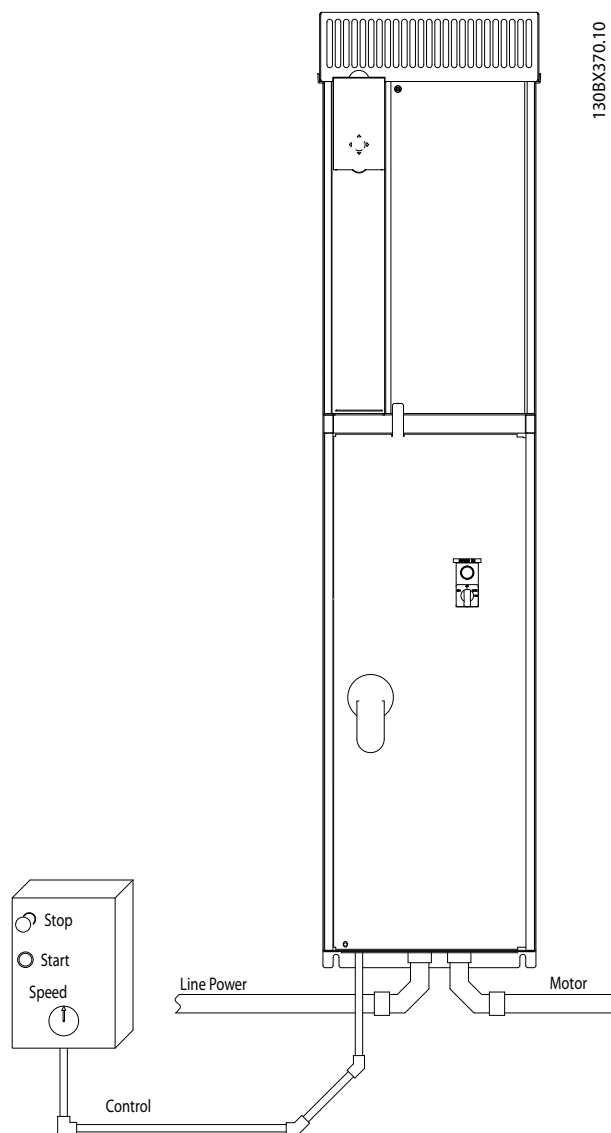

**Figure 2.3 Example of Proper Electrical Installation Using Conduit**

- All adjustable frequency drives must be provided with short-circuit and overcurrent protection. Input fusing is required to provide this protection, see *Figure 2.4*. If not factory supplied, fuses must be provided by the installer as part of installation. See maximum fuse ratings in *10.3.1 Protection*.

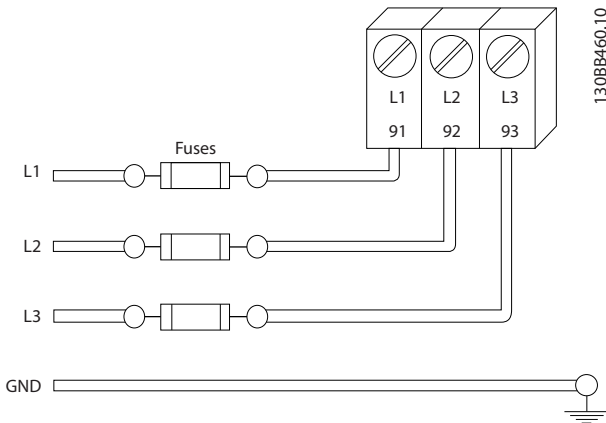

Figure 2.4 Adjustable Frequency Drive Fuses

**Wire Type and Ratings**

- All wiring must comply with local and national regulations regarding cross-section and ambient temperature requirements.
- Danfoss recommends that all power connections be made with a minimum 167° F [75°C] rated copper wire.

**2.4.2 Grounding Requirements**

**⚠ WARNING**

**GROUNDING HAZARD!**

For operator safety, it is important to ground the adjustable frequency drive properly in accordance with national and local electrical codes as well as instructions contained within this document. Do not use conduit connected to the adjustable frequency drive as a replacement for proper grounding. Ground currents are higher than 3.5 mA. Failure to ground the adjustable frequency drive properly could result in death or serious injury.

**NOTE!**

It is the responsibility of the user or certified electrical installer to ensure correct grounding of the equipment in accordance with national and local electrical codes and standards.

- Follow all local and national electrical codes to ground electrical equipment properly
- Proper protective grounding for equipment with ground currents higher than 3.5 mA must be established, see *2.4.2.1 Leakage Current (>3.5 mA)*
- A dedicated ground wire is required for input power, motor power and control wiring
- Use the clamps provided with the equipment for proper ground connections
- Do not ground one adjustable frequency drive to another in a “daisy chain” fashion
- Keep the ground wire connections as short as possible
- Using high-strand wire to reduce electrical noise is recommended
- Follow the motor manufacturer wiring requirements

**2.4.2.1 Leakage Current (>3.5 mA)**

Follow national and local codes regarding protective grounding of equipment with a leakage current >3.5 mA. Adjustable frequency drive technology implies high frequency switching at high power. This will generate a leakage current in the ground connection. A fault current in the adjustable frequency drive at the output power terminals might contain a DC component, which can charge the filter capacitors and cause a transient ground current. The ground leakage current depends on various system configurations including RFI filtering, shielded motor cables, and adjustable frequency drive power.

EN/IEC61800-5-1 (Power Drive System Product Standard) requires special care if the leakage current exceeds 3.5 mA. Grounding must be reinforced in one of the following ways:

- Ground wire of at least 0.016 in<sup>2</sup> [10 mm<sup>2</sup>]
- Two separate ground wires both complying with the dimensioning rules

See EN 60364-5-54 § 543.7 for further information.

**Using RCDs**

Where residual current devices (RCDs)—also known as ground leakage circuit breakers (ELCBs)—are used, comply with the following: residual current devices (RCDs)

- Use RCDs of type B only which are capable of detecting AC and DC currents
- Use RCDs with an inrush delay to prevent faults due to transient ground currents
- Dimension RCDs according to the system configuration and environmental considerations

### 2.4.2.2 Grounding IP20 Enclosures

The adjustable frequency drive can be grounded using conduit or shielded cable. For grounding of the power connections, use the dedicated grounding points as shown in *Figure 2.6*.

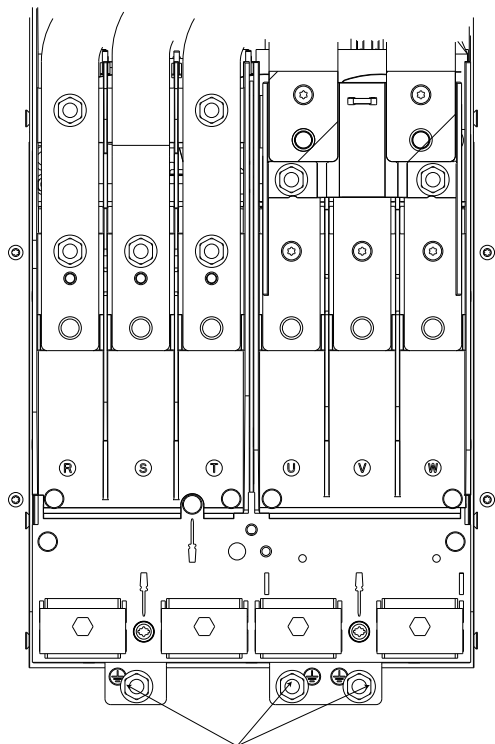

Figure 2.5 Grounding Points for IP20 (Chassis) Enclosures

### 2.4.2.3 Grounding IP21/54 Enclosures

The adjustable frequency drive can be grounded using conduit or shielded cable. For grounding of the power connections, use the dedicated grounding points as shown in *Figure 2.6*.

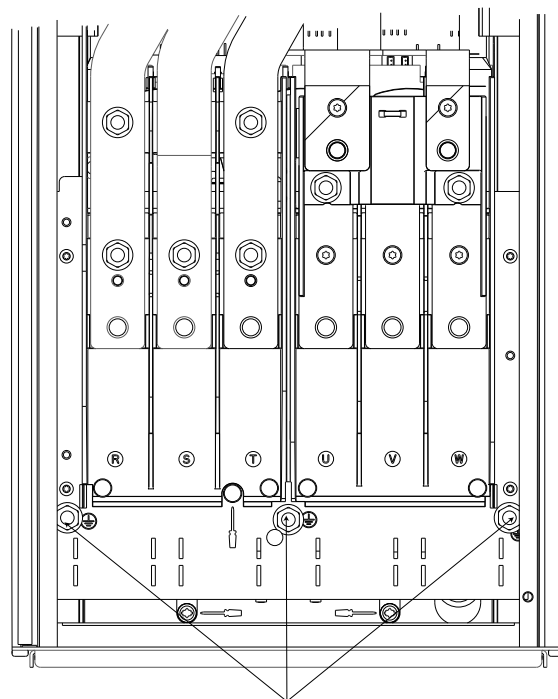

Figure 2.6 Grounding for IP21/54 Enclosures.

### 2.4.3 Motor Connection

#### **⚠ WARNING**

#### **INDUCED VOLTAGE!**

Run output motor cables from multiple adjustable frequency drives separately. Induced voltage from output motor cables run together can charge equipment capacitors even with the equipment turned off and locked out. Failure to run output motor cables separately could result in death or serious injury.

- For maximum cable sizes, see *10.1 Power-dependent Specifications*
- Comply with local and national electrical codes for cable sizes.
- Connector plates are provided at the base of IP21/54 and higher (NEMA1/12) units
- Do not install power factor correction capacitors between the adjustable frequency drive and the motor
- Do not wire a starting or pole-changing device between the adjustable frequency drive and the motor.

- Connect the 3-phase motor wiring to terminals 96 (U), 97 (V), and 98 (W).
- Ground the cable in accordance with the instructions provided
- Torque terminals in accordance with the information provided in *10.3.4 Connection Tightening Torques*
- Follow the motor manufacturer wiring requirements

2.4.3.1 Terminal Locations: D1h-D4h

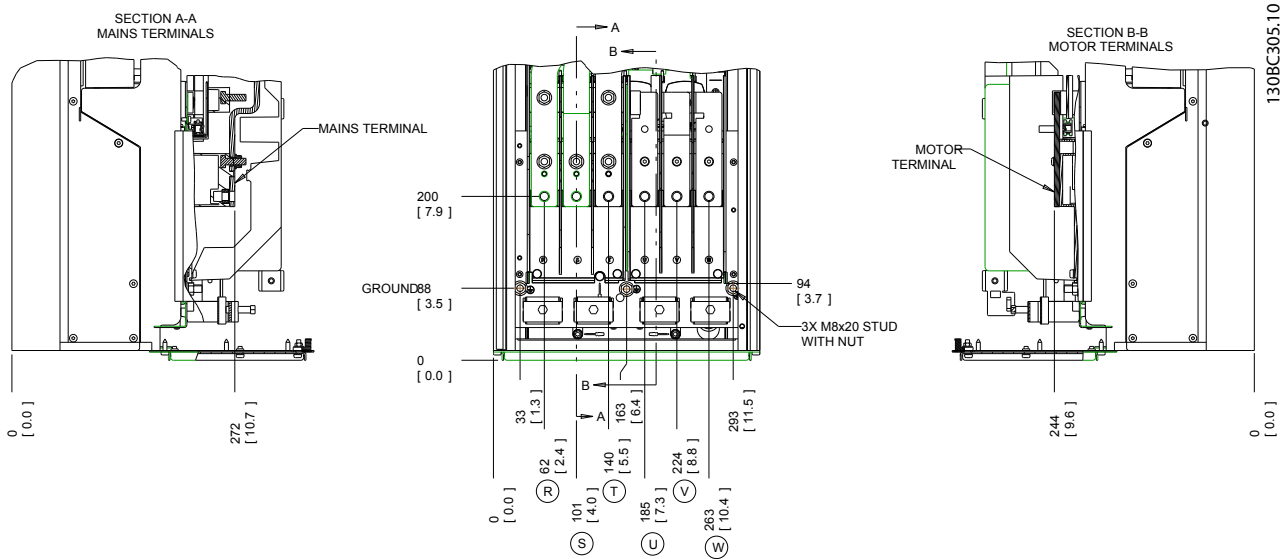

Figure 2.7 Terminal Locations D1h

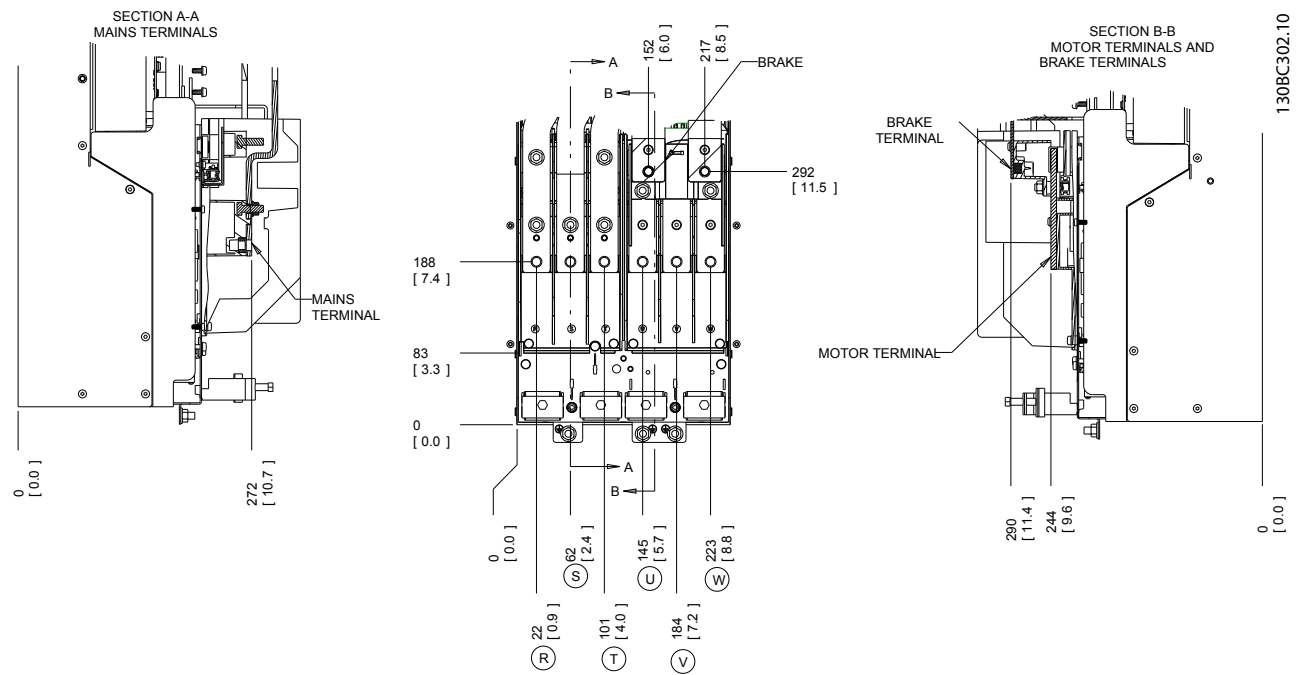

Figure 2.8 Terminal Locations D3h

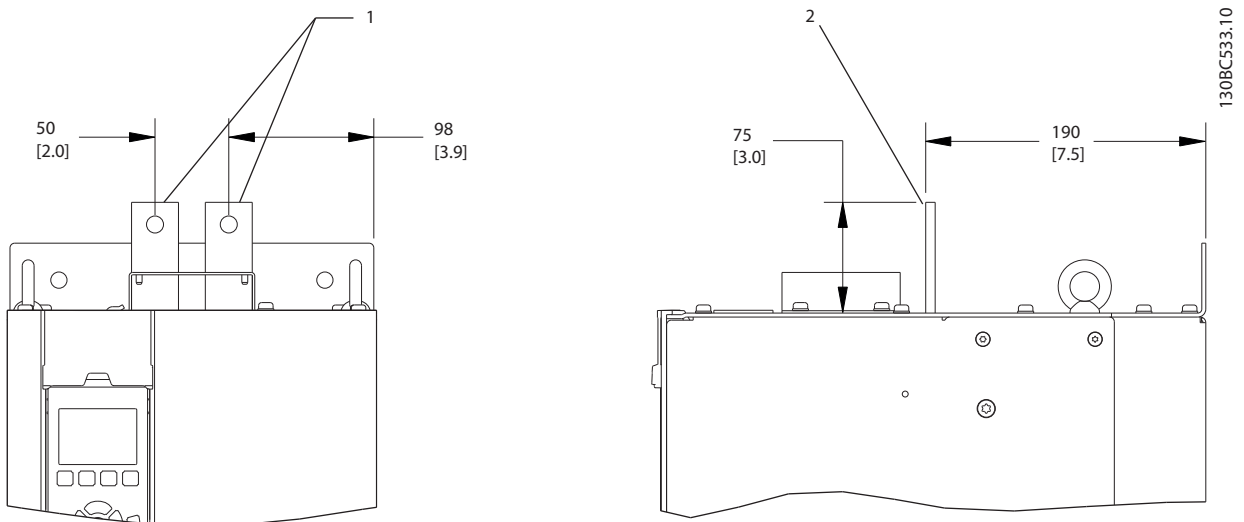

Figure 2.9 Load share and Regeneration Terminals, D3h

1	Front view
2	Side view

Table 2.3

2

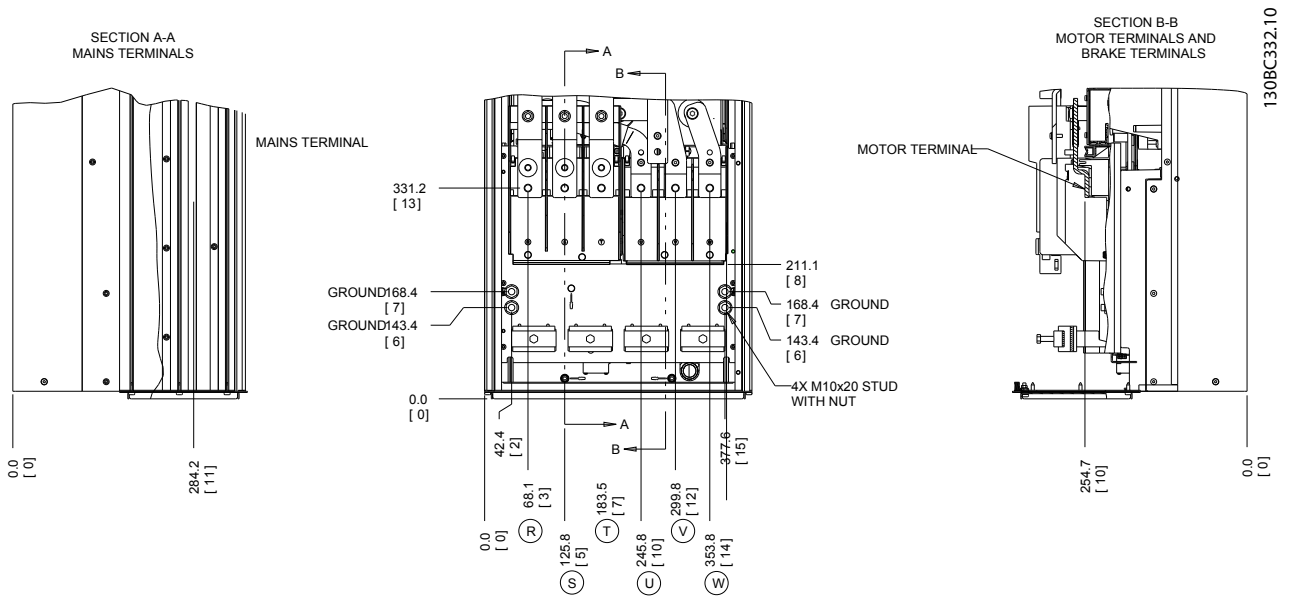

Figure 2.10 Terminal Locations D2h

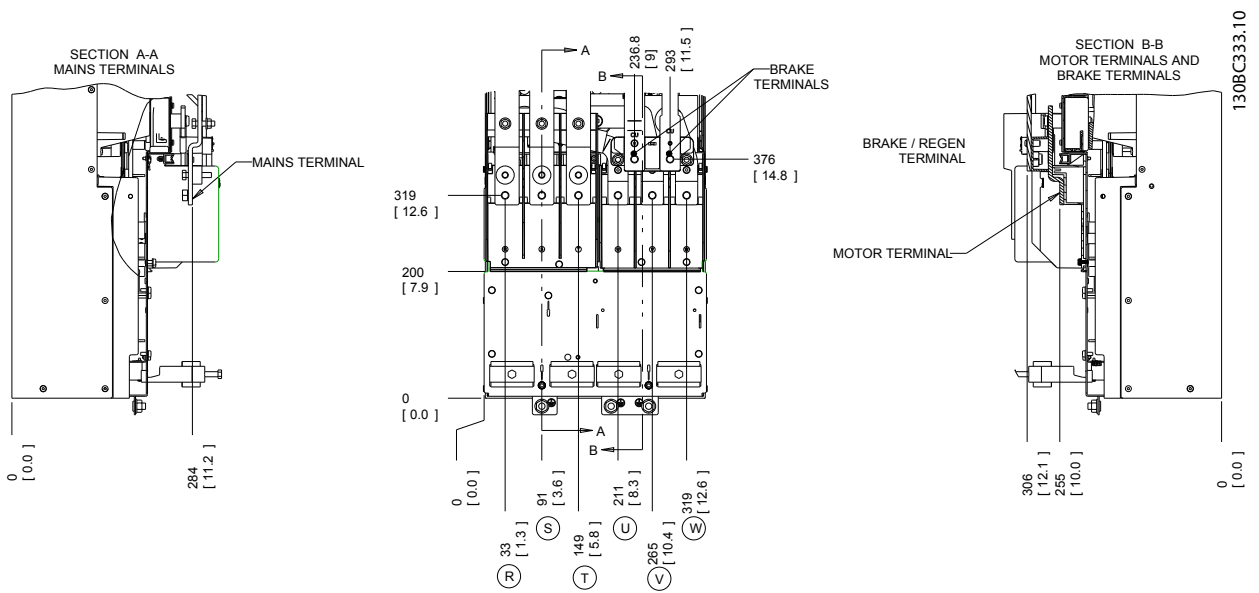

Figure 2.11 Terminal Locations D4h



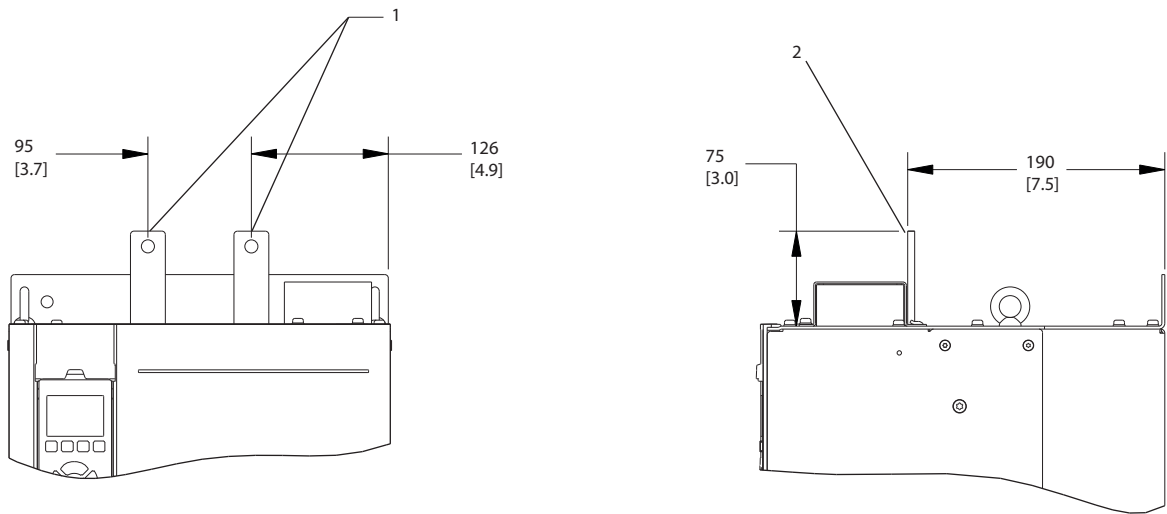

Figure 2.12 Load share and Regeneration Terminals, D4h

1	Front view
2	Side view

Table 2.4

2.4.3.2 Terminal Locations: D5h-D8h

2

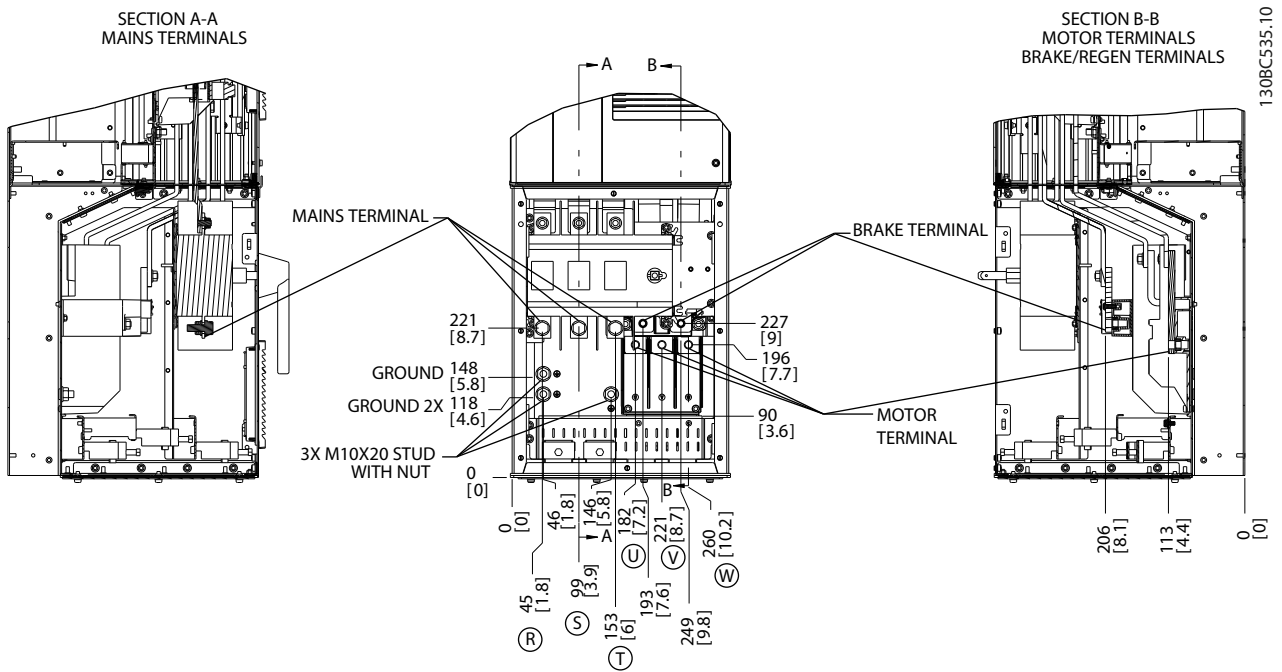
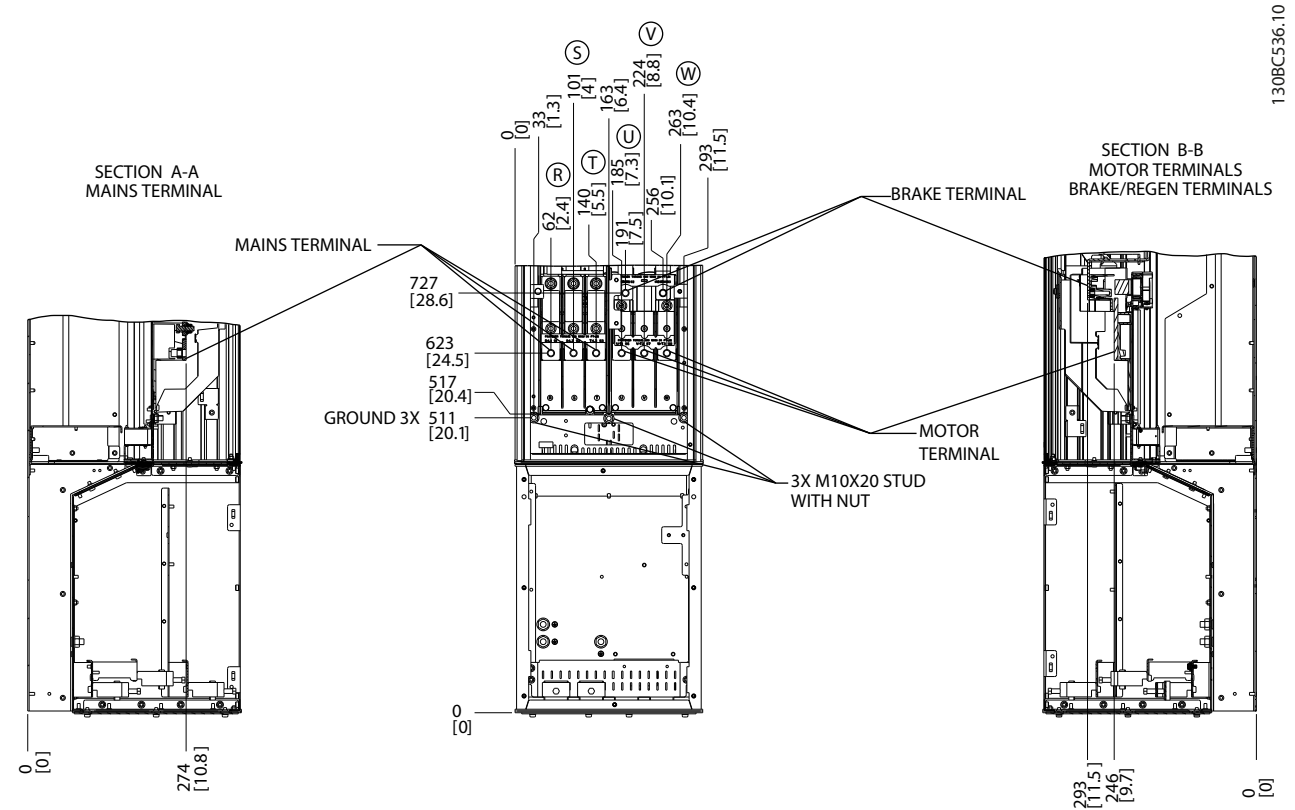
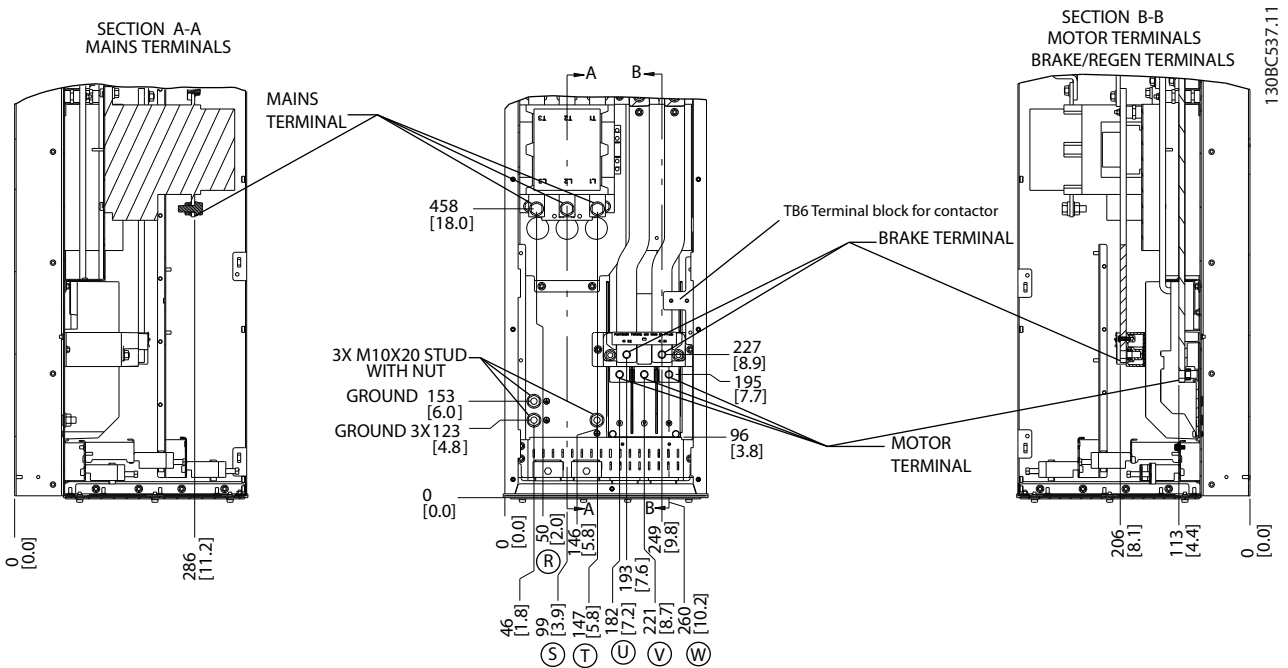

Figure 2.13 Terminal Locations, D5h with Disconnect Option



130BC536.10

Figure 2.14 Terminal Locations, D5h with Brake Option



130BC537.11

Figure 2.15 Terminal Locations, D6h with Contactor Option

2

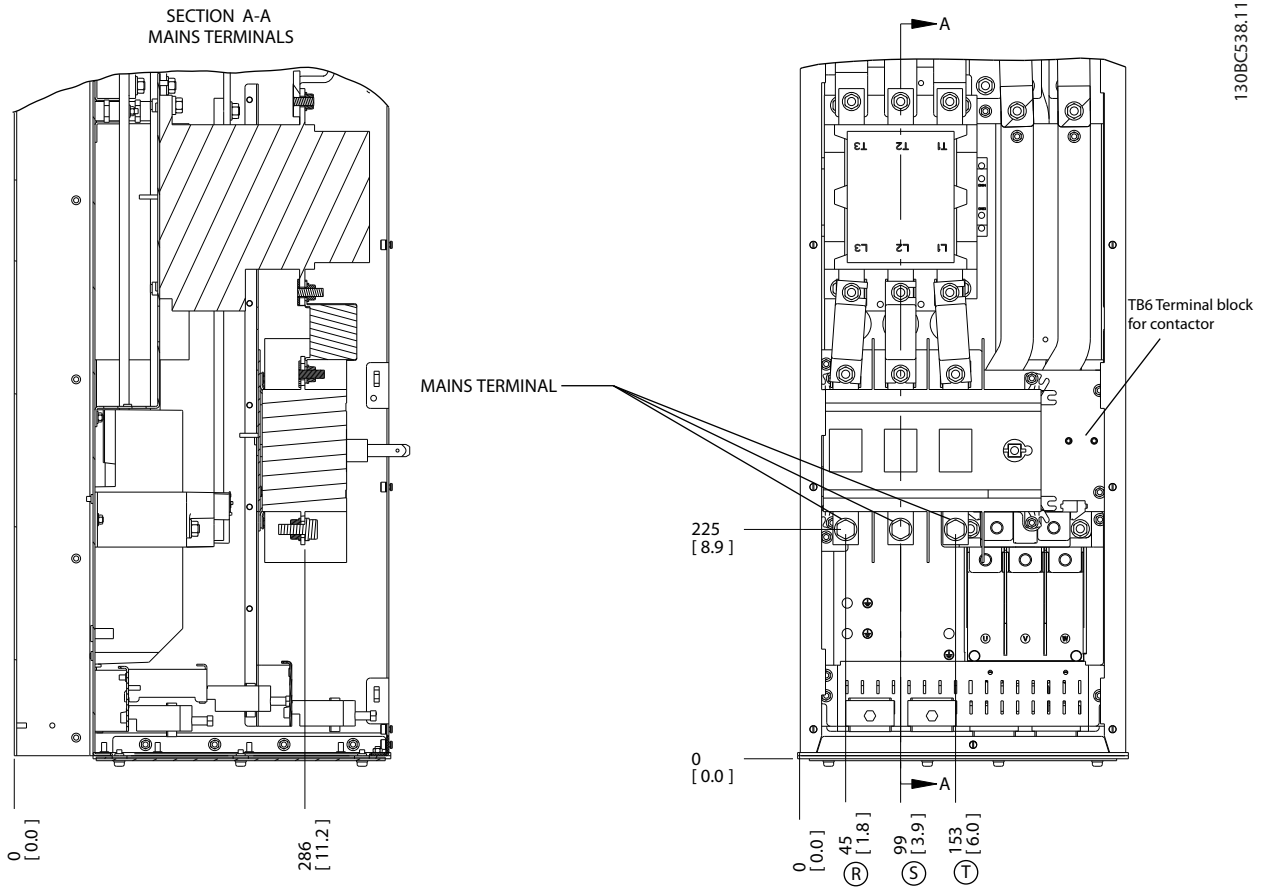

Figure 2.16 Terminal Locations, D6h with Contactor and Disconnect Options

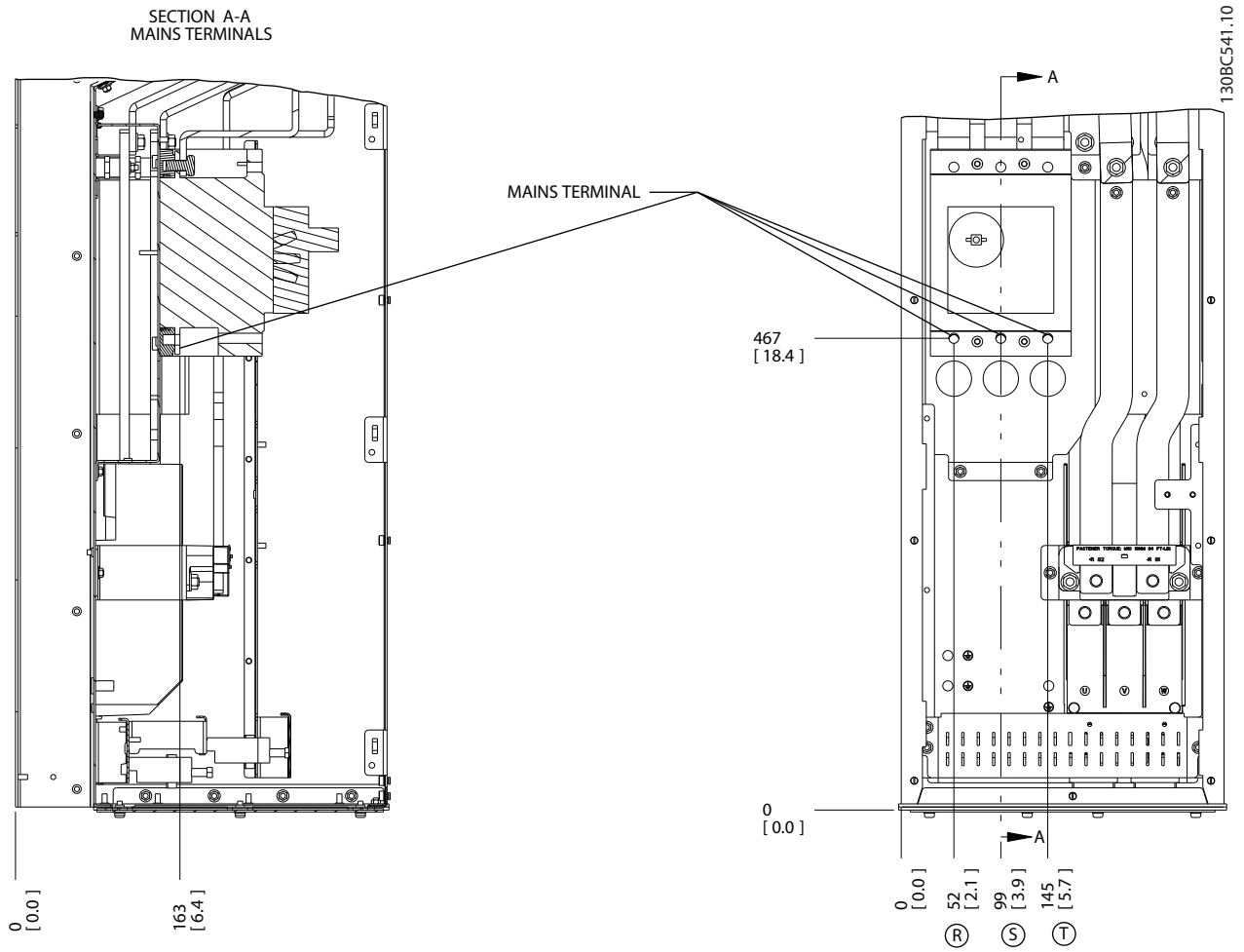
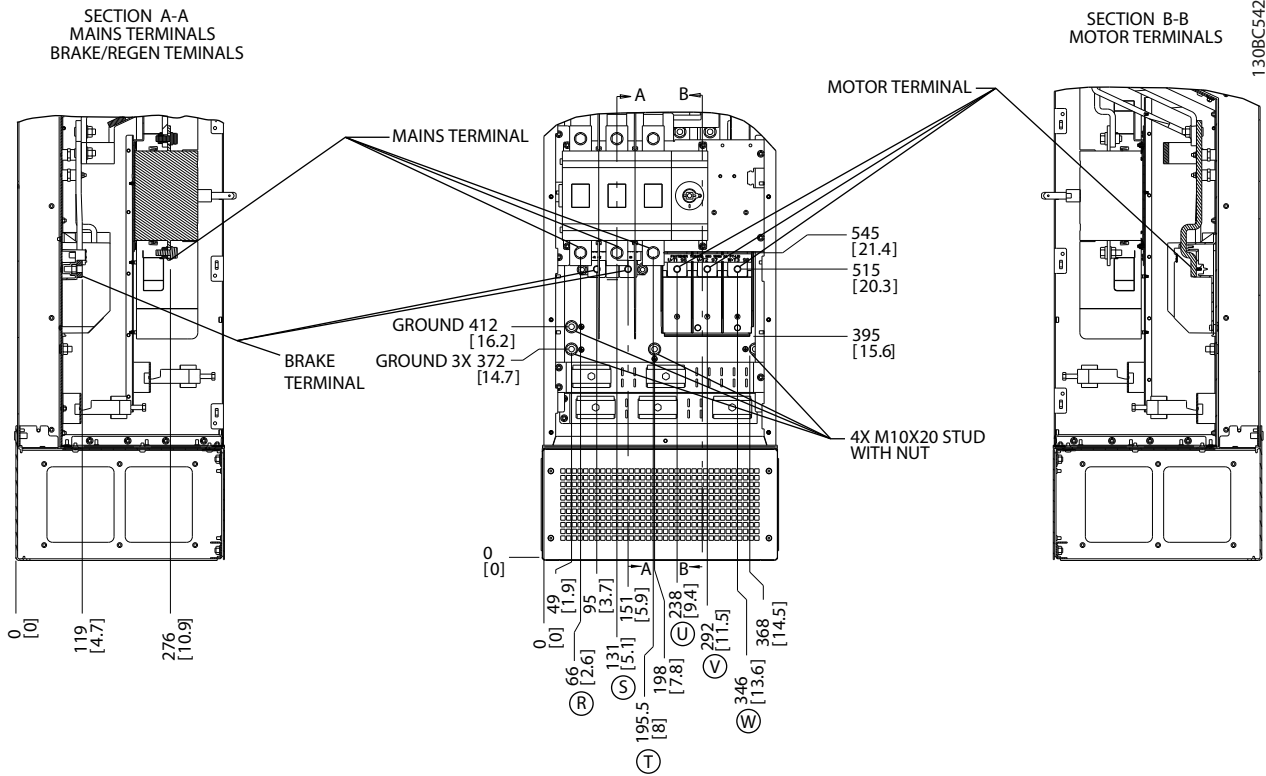

Figure 2.17 Terminal Locations, D6h with Circuit Breaker Option

2



130BC542.10

Figure 2.18 Terminal Locations, D7h with Disconnect Option

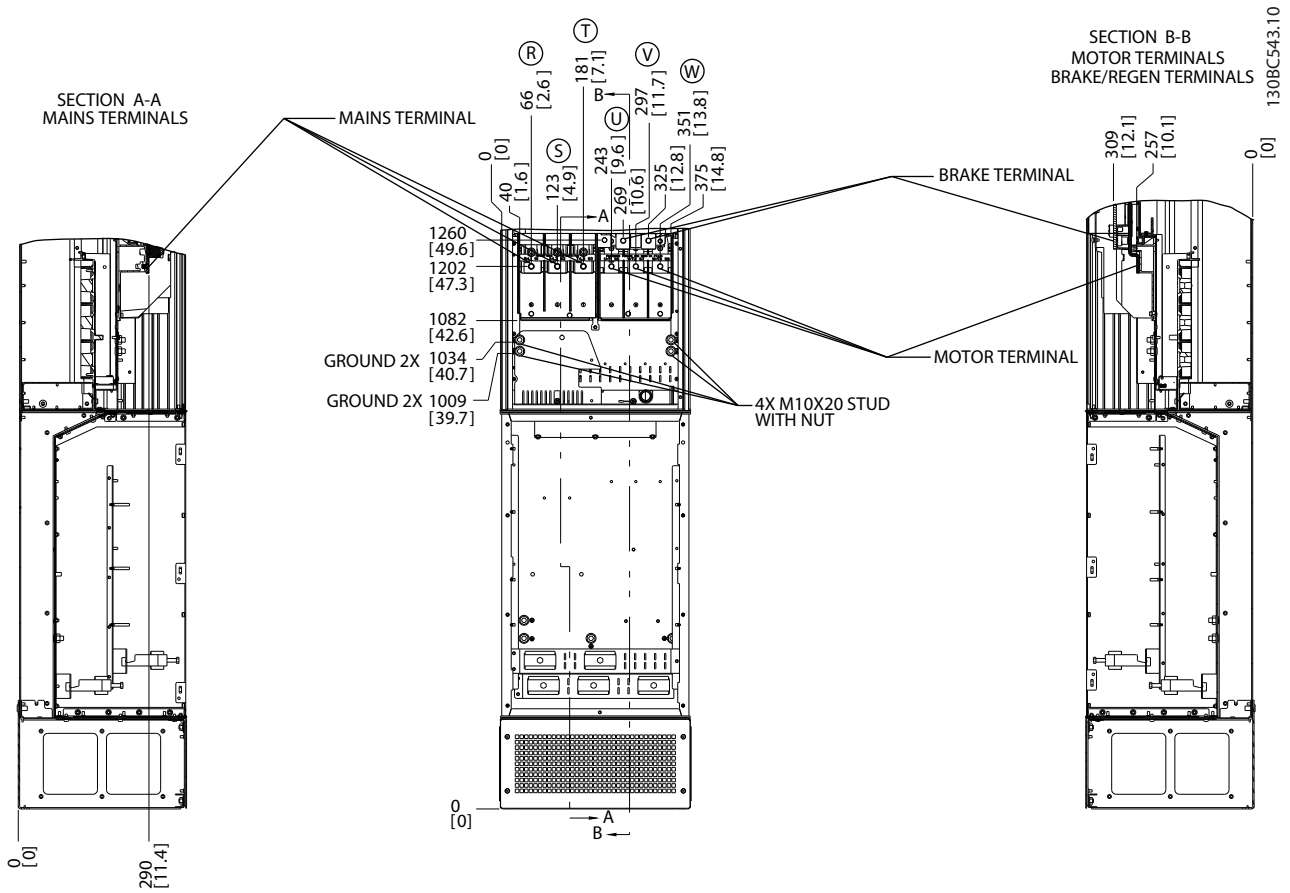

Figure 2.19 Terminal Locations, D7h with Brake Option

2

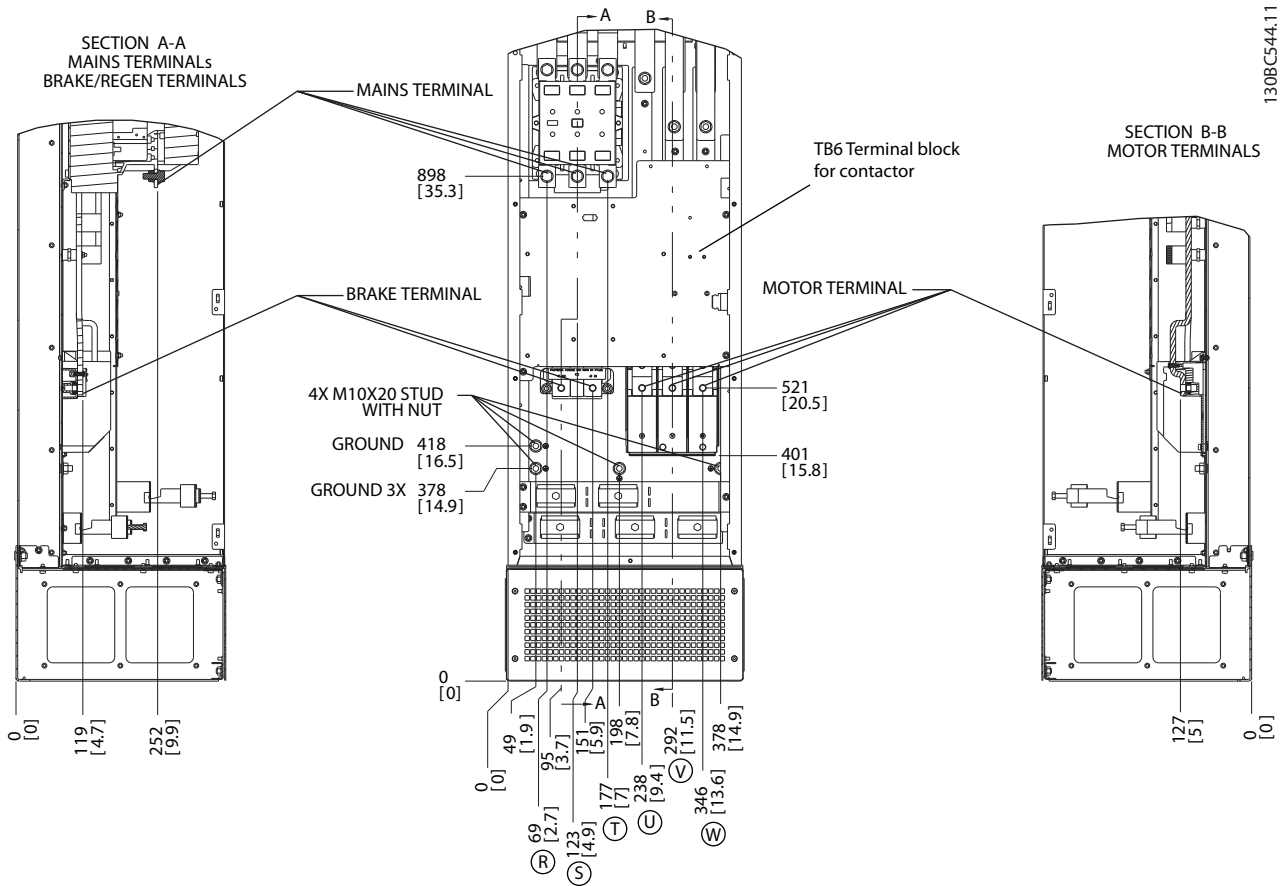

Figure 2.20 Terminal Locations, D8h with Contactor Option



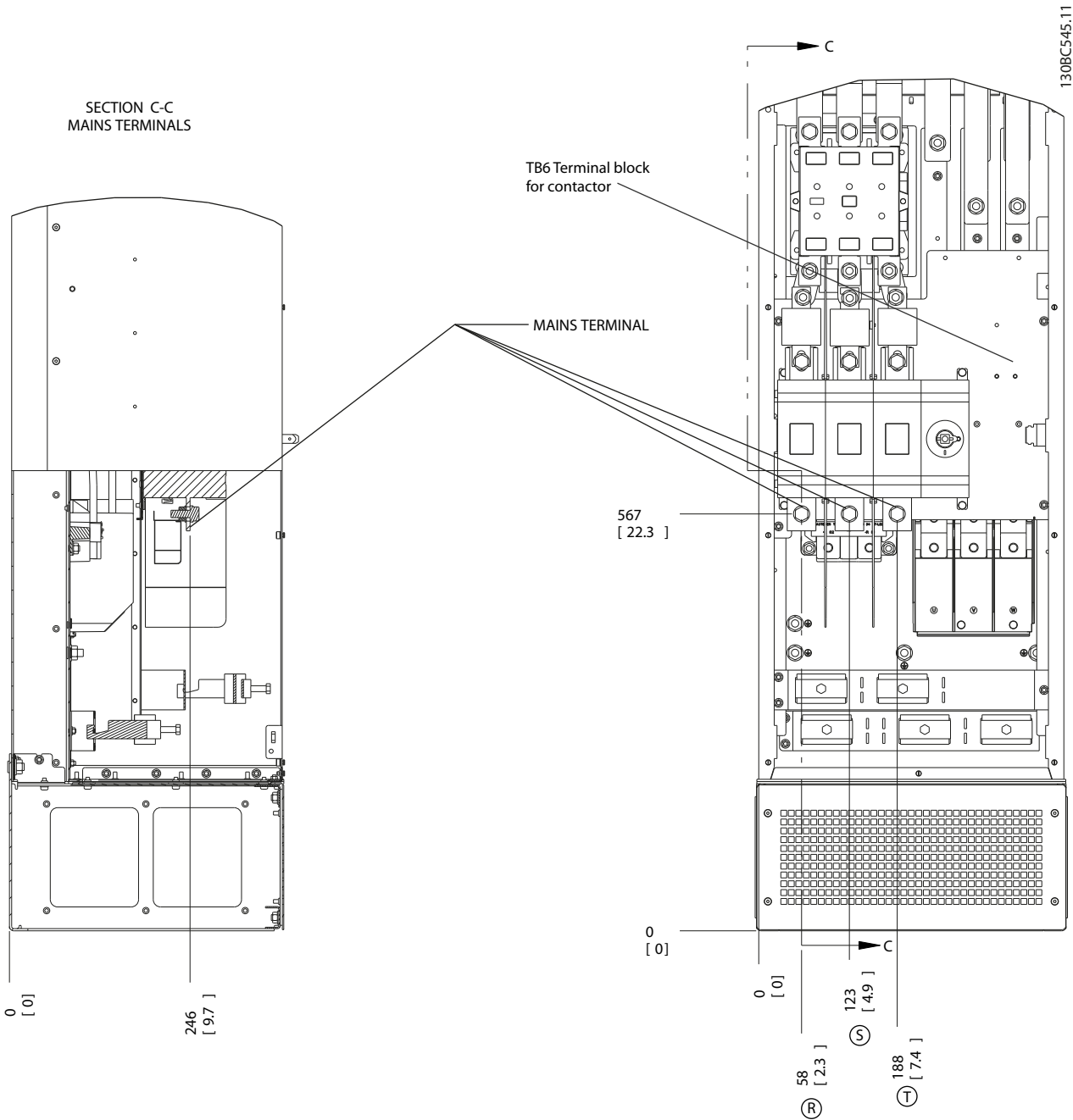

Figure 2.21 Terminal Locations, D8h with Contactor and Disconnect Options

2

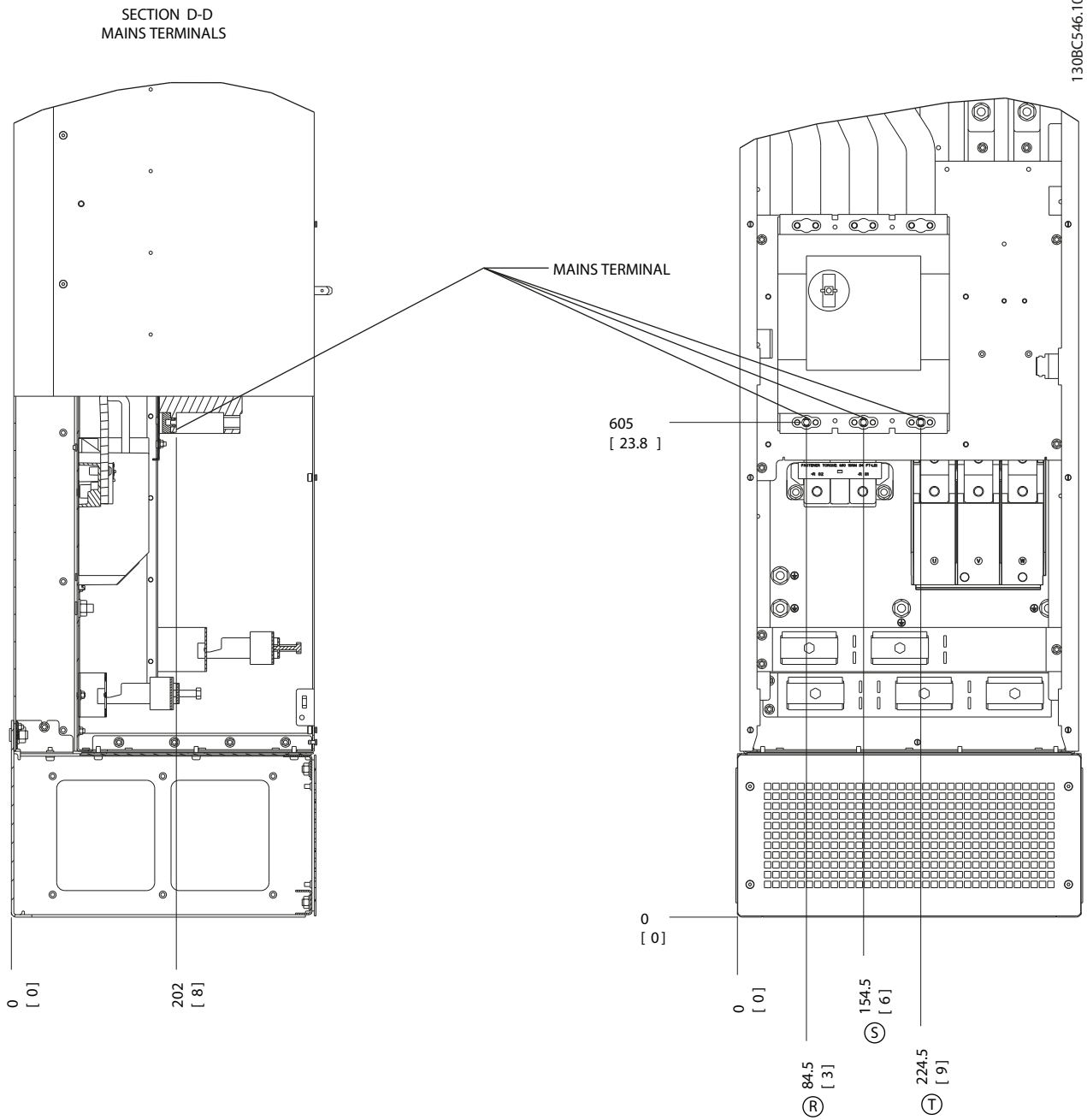

Figure 2.22 Terminal Locations, D8h with Circuit Breaker Option

### 2.4.4 Motor Cable

The motor must be connected to terminals U/T1/96, V/T2/97, W/T3/98. Ground to terminal 99. All types of three-phase asynchronous standard motors can be used with an adjustable frequency drive unit. The factory setting is for clockwise rotation with the adjustable frequency drive output connected as follows:

Terminal no.	Function
96, 97, 98, 99	Line power U/T1, V/T2, W/T3 Ground

Table 2.5

### 2.4.5 Motor Rotation Check

The direction of rotation can be changed by switching two phases in the motor cable or by changing the setting of 4-10 *Motor Speed Direction*.

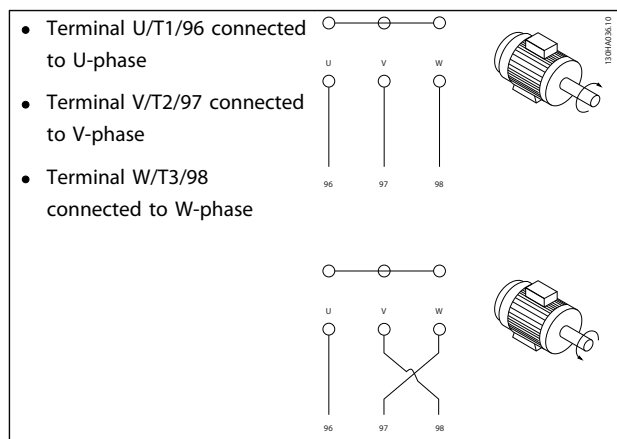

Table 2.6

A motor rotation check can be performed using 1-28 *Motor Rotation Check* and following the steps shown in the display.

### 2.4.6 AC Line Input Connection

- Size wiring is based upon the input current of the adjustable frequency drive
- Comply with local and national electrical codes for cable sizes.
- Connect 3-phase AC input power wiring to terminals L1, L2, and L3 (see Figure 2.23)

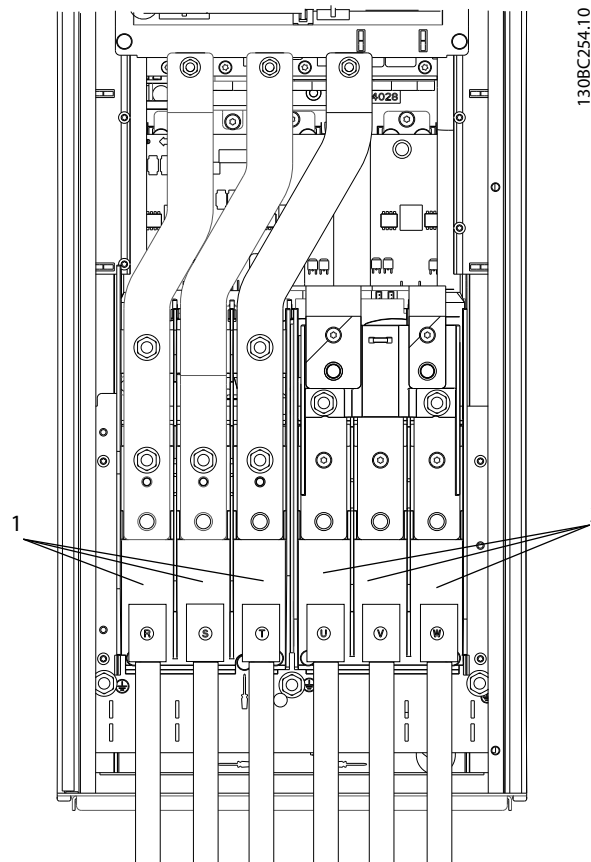

Figure 2.23 Connecting to AC Line Power

1	AC line input connections
2	Motor connection

Table 2.7

- Ground the cable in accordance with the instructions provided
- All adjustable frequency drives may be used with an isolated input source as well as with ground reference power lines. When supplied from an isolated line power source (IT line power or floating delta) or TT/TN-S line power with a grounded leg (grounded delta), set 14-50 *RFI 1* to OFF. When off, the internal RFI filter capacitors between the chassis and the intermediate circuit are isolated to avoid damage to the intermediate circuit and to reduce ground capacity currents in accordance with IEC 61800-3.

## 2.5 Control Wiring Connection

- Isolate control wiring from high power components in the adjustable frequency drive
- If the adjustable frequency drive is connected to a thermistor, for PELV isolation, optional thermistor control wiring must be reinforced/double insulated. A 24 V DC supply voltage is recommended.

### 2.5.1 Access

All terminals to the control cables are located underneath the LCP on the inside of the adjustable frequency drive. To access, open the door (IP21/54) or remove the front panel (IP20).

### 2.5.2 Using Shielded Control Cables

Danfoss recommends braided shielded/armored cables to optimize EMC immunity of the control cables and the EMC emission from the motor cables.

The ability of a cable to reduce the incoming and outgoing radiation of electric noise depends on the transfer impedance ( $Z_T$ ). The shield of a cable is normally designed to reduce the transfer of electric noise; however, a shield with a lower transfer impedance ( $Z_T$ ) value is more effective than a shield with a higher transfer impedance ( $Z_T$ ).

Transfer impedance ( $Z_T$ ) is rarely stated by cable manufacturers, but it is often possible to estimate transfer impedance ( $Z_T$ ) by assessing the physical design of the cable.

**Transfer impedance ( $Z_T$ ) can be assessed on the basis of the following factors:**

- The conductivity of the shield material
  - The contact resistance between the individual shield conductors
  - The shield coverage, i.e., the physical area of the cable covered by the shield - often stated as a percentage value
  - Shield type, i.e., braided or twisted pattern
- a. Aluminum-clad with copper wire
  - b. Twisted copper wire or armored steel wire cable
  - c. Single-layer braided copper wire with varying percentage shield coverage.

This is the typical Danfoss reference cable.

- a. Double-layer braided copper wire
- b. Twin layer of braided copper wire with a magnetic, shielded/armored intermediate layer
- c. Cable that runs in copper tube or steel tube
- d. Lead cable with 0.043 in [1.1 mm] wall thickness

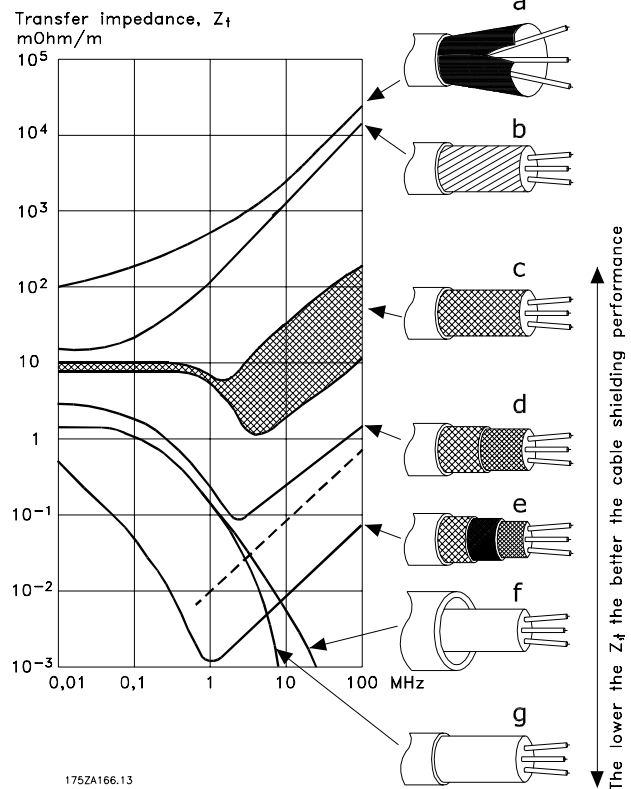

Figure 2.24

### 2.5.3 Grounding of Shielded Control Cables

#### Correct shielding

The preferred method in most cases is to secure control and serial communication cables with shielding clamps provided at both ends to ensure best possible high frequency cable contact. If the ground potential between the adjustable frequency drive and the PLC is different, electric noise may occur that will disturb the entire system. Solve this problem by fitting an equalizing cable next to the control cable. Minimum cable cross-section: 0.025 in<sup>2</sup> [16 mm<sup>2</sup>].

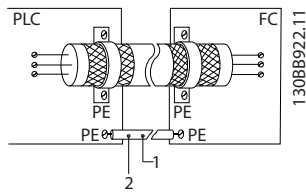

Figure 2.25

1	Min. 0.025 in <sup>2</sup> [16 mm <sup>2</sup> ]
2	Equalizing cable

Table 2.8

#### 50/60 Hz ground loops

With very long control cables, ground loops may occur. To eliminate ground loops, connect one end of the shield-to-ground with a 100 nF capacitor (keeping leads short).

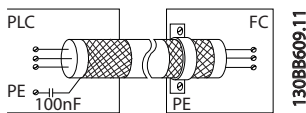

Figure 2.26

#### Avoid EMC noise on serial communication

This terminal is connected to ground via an internal RC link. Use twisted-pair cables to reduce interference between conductors. The recommended method is shown below:

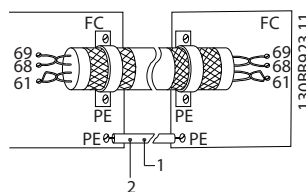

Figure 2.27

1	Min. 0.025 in <sup>2</sup> [16 mm <sup>2</sup> ]
2	Equalizing cable

Table 2.9

Alternatively, the connection to terminal 61 can be omitted:

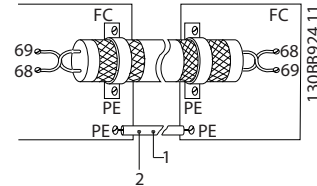

Figure 2.28

1	Min. 0.025 in <sup>2</sup> [16 mm <sup>2</sup> ]
2	Equalizing cable

Table 2.10

### 2.5.4 Control Terminal Types

Terminal functions and default settings are summarized in 2.5.6 Control Terminal Functions.

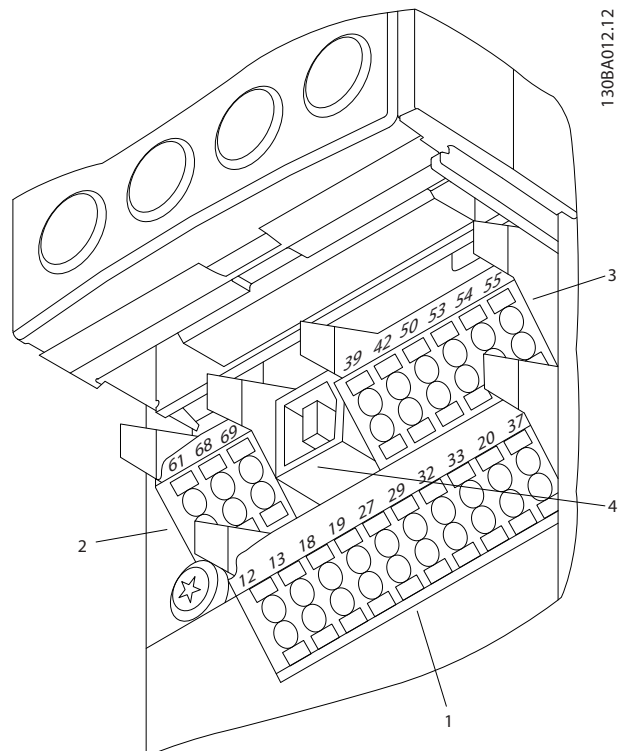

Figure 2.29 Control Terminal Locations

- **Connector 1** provides four programmable digital input terminals, two additional digital terminals programmable as either input or output, a 24 V DC terminal supply voltage, and a common for optional customer-supplied 24 V DC voltage
- **Connector 2** terminals (+)68 and (-)69 are for an RS-485 serial communications connection
- **Connector 3** provides two analog inputs, one analog output, 10 V DC supply voltage, and commons for the inputs and output
- **Connector 4** is a USB port available for use with the MCT 10 Set-up Software
- Also provided are two Form C relay outputs that are in various locations depending upon the adjustable frequency drive configuration and size
- Some options available for ordering with the unit may provide additional terminals. See the manual provided with the equipment option

### 2.5.5 Wiring to Control Terminals

Terminal plugs can be removed for easy access.

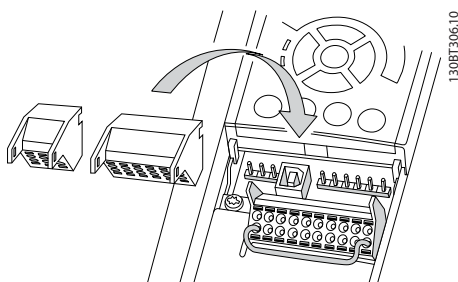

Figure 2.30 Removal of Control Terminals

### 2.5.6 Control Terminal Functions

Adjustable frequency drive functions are commanded by receiving control input signals.

- Each terminal must be programmed for the function it will be supporting in the parameters associated with that terminal. See *5 Programming* and *6 Application Examples* for terminals and associated parameters.
- It is important to confirm that the control terminal is programmed for the correct function. See *5 Programming* for details on accessing parameters and programming.

- The default terminal programming is intended to initiate adjustable frequency drive functioning in a typical operational mode

#### 2.5.6.1 Terminal 53 and 54 Switches

- Analog input terminals 53 and 54 can select either voltage (-10 to 10 V) or current (0/4–20 mA) input signals
- Remove power to the adjustable frequency drive before changing switch positions.
- Set switches A53 and A54 to select the signal type. U selects voltage, I selects current
- The switches are accessible when the LCP has been removed (see *Figure 2.31*).

#### NOTE!

Some option cards available for the unit may cover these switches and must be removed to change switch settings. Always remove power to the unit before removing option cards.

- Terminal 53 default is for a speed reference signal in open-loop set in *16-61 Terminal 53 Switch Setting*
- Terminal 54 default is for a feedback signal in closed-loop set in *16-63 Terminal 54 Switch Setting*

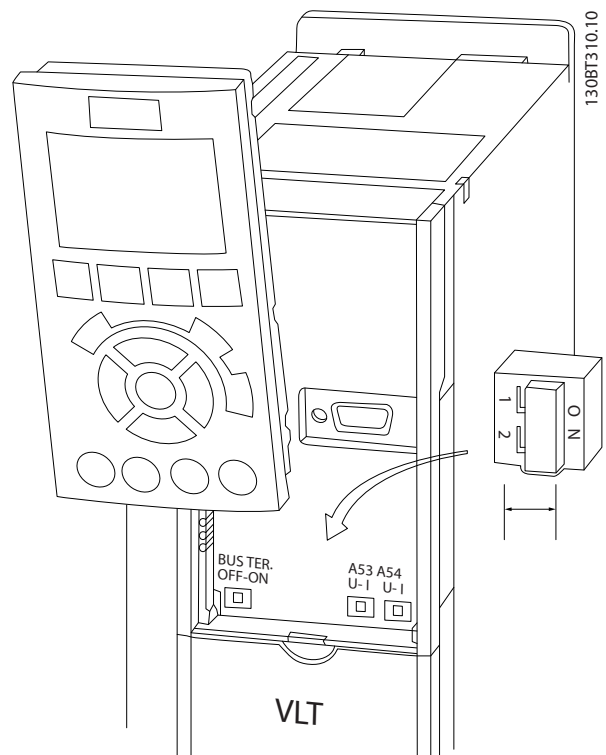

Figure 2.31 Location of Terminals 53 and 54 Switches and Bus Termination Switch

## 2.6 Serial Communication

RS-485 is a two-wire bus interface compatible with multi-drop network topology, i.e., nodes can be connected as a bus, or via drop cables from a common trunk line. A total of 32 nodes can be connected to one network segment. Repeaters divide network segments. Each repeater functions as a node within the segment in which it is installed. Each node connected within a given network must have a unique node address across all segments. Terminate each segment at both ends, using either the termination switch (S801) of the adjustable frequency drive or a biased termination resistor network. Always use shielded twisted pair (STP) cable for bus cabling, and always follow good common installation practice. Low-impedance ground connection of the shield at every node is important, including at high frequencies. Thus, connect a large surface of the shield to ground, for example with a cable clamp or a conductive cable connector. It may be necessary to apply potential-equalizing cables to maintain the same ground potential throughout the network, particularly in installations with long cables. To prevent impedance mismatch, always use the same type of cable throughout the entire network. When connecting a motor to the adjustable frequency drive, always use shielded motor cable.

Cable	Shielded twisted pair (STP)
Impedance	120 Ω
Max. cable length	4,000 ft [1,200 m] (including drop lines) 1,650 ft [500 m] station-to-station

Table 2.11

## 2.7 Optional Equipment

### 2.7.1 Load Share Terminals

Load share terminals enable the connection of the DC circuits of several adjustable frequency drives. Load share terminals are available in IP20 adjustable frequency drives and extend out the top of the adjustable frequency drive. A terminal cover, supplied with the adjustable frequency drive, must be installed to maintain the IP20 rating of the enclosure. *Figure 2.32* shows both the covered and uncovered terminals.

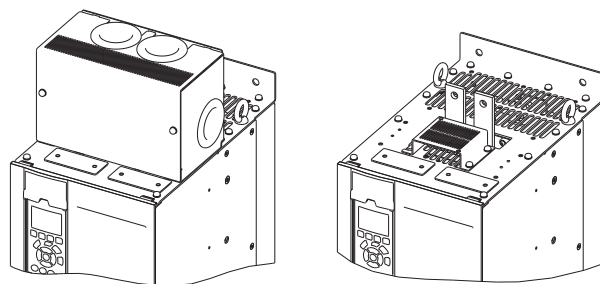

Figure 2.32 Load Share or Regeneration Terminal with Cover (L) and without Cover (R)

### 2.7.2 Regeneration Terminals

Regen (regeneration) terminals can be supplied for applications that have a regenerative load. A regenerative unit, supplied by a third party, connects to the regen terminals so that power can be regenerated back onto line power, resulting in energy savings. Regen terminals are available in IP20 adjustable frequency drives and extend out the top of the adjustable frequency drive. A terminal cover, supplied with the adjustable frequency drive, must be installed to maintain the IP20 rating of the enclosure. *Figure 2.32* shows both the covered and uncovered terminals.

### 2.7.3 Anti-condensation Heater

An anti-condensation heater can be installed inside the adjustable frequency drive to prevent condensation from forming inside the enclosure when the unit is turned off. The heater is controlled by customer-supplied 230 V AC. For best results, operate the heater only when the unit is not running and turn the heater off when the unit is running.

### 2.7.4 Brake Chopper

A brake chopper can be supplied for applications that have a regenerative load. The brake chopper connects to a brake resistor, which consumes the braking energy, preventing an overvoltage fault on the DC bus. The braking chopper is automatically activated when the DC bus voltage exceeds a specified level, depending on the nominal voltage of the adjustable frequency drive.

### 2.7.5 Line Power Shield

The line power shield is a Lexan cover installed inside the enclosure to provide protection according to VBG-4 accident-prevention requirements.

### 2.7.6 Line Power Disconnect

The disconnect option is available in both varieties of option cabinets. The position of the disconnect changes based on the size of the options cabinet and whether or not other options are present. *Table 2.12* provides more detail about which disconnects are used.

Voltage	Adjustable frequency drive model	Disconnect manufacturer and type
380–500 V	N110T5–N160T4	ABB OT400U03
	N200T5–N315T4	ABB OT600U03
525–690 V	N75KT7–N160T7	ABB OT400U03
	N200T7–N400T7	ABB OT600U03

Table 2.12

### 2.7.7 Contactor

The contactor is powered by a customer-supplied 230 V AC 50/60 Hz signal.

Voltage	Adjustable frequency drive model	Contactor manufacturer and type	IEC utilization category
380–500 V	N110T5–N160T4	GE CK95BE311N	AC-3
	N200T5–N250T4	GE CK11CE311N	AC-3
	N315T4	GE CK11CE311N	AC-1
525–690 V	N75KT7–N160T7	GE CK95BE311N	AC-3
	N200T7–N400T7	GE CK11CE311N	AC-3

Table 2.13

### NOTE!

In applications requiring UL listing, when the adjustable frequency drive is supplied with a contactor, the customer must provide external fusing to maintain the UL rating of the adjustable frequency drive and a short circuit current rating of 100,000 A. See *10.1.1 Power-dependent Specifications* for fuse recommendations.

### 2.7.8 Circuit Breaker

*Table 2.14* provides details on the type of circuit breaker provided as an option with the various units and power ranges.

Voltage	Adjustable frequency drive model	Circuit breaker manufacturer and type
380–500 V	N110T5–N132T5	ABB T5L400TW
	N160T5	ABB T5LQ400TW
	N200T5	ABB T6L600TW
	N250T5	ABB T6LQ600TW
	N315T5	ABB T6LQ800TW
525–690 V	N75KT7–N160T7	ABB T5L400TW
	N200T7–N315T7	ABB T6L600TW
	N400T7	ABB T6LQ600TW

Table 2.14



## 3 Startup and Commissioning

### 3.1 Pre-start

#### CAUTION

Before applying power to the unit, inspect the entire installation as detailed in *Table 3.1*. Check mark those items when completed.

Inspect for	Description	<input checked="" type="checkbox"/>
Auxiliary equipment	<ul style="list-style-type: none"> <li>Look for auxiliary equipment, switches, disconnects, or input fuses/circuit breakers that may reside on the input power side of the adjustable frequency drive or output side to the motor. Ensure that they are ready for full speed operation.</li> <li>Check function and installation of any sensors used for feedback to the adjustable frequency drive</li> <li>Remove power factor correction caps on motor(s), if present</li> </ul>	
Cable routing	<ul style="list-style-type: none"> <li>Ensure that input power, motor wiring, and control wiring are separated or in three separate metallic conduits for high frequency noise isolation</li> </ul>	
Control wiring	<ul style="list-style-type: none"> <li>Check for broken or damaged wires and loose connections.</li> <li>Check that control wiring is isolated from power and motor wiring for noise immunity.</li> <li>Check the voltage source of the signals, if necessary.</li> <li>The use of shielded cable or twisted pair is recommended. Ensure that the shield is terminated correctly</li> </ul>	
Cooling clearance	<ul style="list-style-type: none"> <li>Make sure that the top and bottom clearance is adequate to ensure proper airflow for cooling.</li> </ul>	
EMC considerations	<ul style="list-style-type: none"> <li>Check for proper installation regarding electromagnetic compatibility.</li> </ul>	
Environmental considerations	<ul style="list-style-type: none"> <li>See equipment label for the maximum ambient operating temperature limits.</li> <li>Humidity levels must be 5%–95% non-condensing.</li> </ul>	
Fusing and circuit breakers	<ul style="list-style-type: none"> <li>Check for proper fusing or circuit breakers.</li> <li>Check that all fuses are inserted firmly and in operational condition and that all circuit breakers are in the open position.</li> </ul>	
Grounding	<ul style="list-style-type: none"> <li>The unit requires a ground wire from its chassis to the building ground</li> <li>Check for good ground connections that are tight and free of oxidation</li> <li>Grounding to conduit or mounting the back panel to a metal surface is not a suitable ground</li> </ul>	
Input and output power wiring	<ul style="list-style-type: none"> <li>Check for loose connections.</li> <li>Check that motor and line power are in separate conduit or separated shielded cables.</li> </ul>	
Panel interior	<ul style="list-style-type: none"> <li>Make sure that the unit interior is free of dirt, metal chips, moisture, and corrosion.</li> </ul>	
Switches	<ul style="list-style-type: none"> <li>Ensure that all switch and disconnect settings are in the proper positions</li> </ul>	
Vibration	<ul style="list-style-type: none"> <li>Check that the unit is mounted solidly or that shock mounts are used, as necessary.</li> <li>Check for an unusual amount of vibration</li> </ul>	

Table 3.1 Startup Check List

## 3.2 Applying Power

### **⚠ WARNING**

#### **HIGH VOLTAGE!**

Adjustable frequency drives contain high voltage when connected to AC line power. Installation, startup and maintenance should be performed by qualified personnel only. Failure to perform installation, startup and maintenance by qualified personnel could result in death or serious injury.

### **⚠ WARNING**

#### **UNINTENDED START!**

When the adjustable frequency drive is connected to AC line power, the motor may start at any time. The adjustable frequency drive, motor, and any driven equipment must be in operational readiness. Failure to be in operational readiness when the adjustable frequency drive is connected to AC line power could result in death, serious injury, equipment, or property damage.

1. Confirm input voltage is balanced within 3%. If not, correct input voltage imbalance before proceeding. Repeat procedure after voltage correction.
2. Ensure optional equipment wiring, if present, matches installation application.
3. Ensure that all operator devices are in the OFF position. Panel doors closed or cover mounted.
4. Apply power to the unit. DO NOT start the adjustable frequency drive at this time. For units with a disconnect switch, turn to the ON position to apply power to the adjustable frequency drive.

#### **NOTE!**

If the status line at the bottom of the LCP reads **AUTO REMOTE COAST**, this indicates that the unit is ready to operate but is missing an input signal on terminal 27.

## 3.3 Basic Operational Programming

For best performance, adjustable frequency drives require basic operational programming before running. Basic operational programming requires entering motor nameplate data for the motor being operated and the minimum and maximum motor speeds. The recommended parameter settings are intended for startup and checkout purposes. Application settings may vary. See *4.1 Local Control Panel* for detailed instructions on entering data through the LCP.

Enter data with power ON, but before operating the adjustable frequency drive. There are two ways of programming the adjustable frequency drive: either by using the Smart Application Set-up (SAS) or by using the procedure described further down. The SAS is a quick wizard for setting up the most commonly used applications. At first power-up and after a reset, the SAS appears on the LCP. Follow the instructions that appear on the successive screens for setting-up the applications listed. SAS can also be found under the Quick Menu. [Info] can be used throughout the Smart Set-up to see help information for various selections, settings, and messages.

#### **NOTE!**

The start conditions will be ignored while in the wizard.

#### **NOTE!**

If no action is taken after first power-up or reset, the SAS screen will automatically disappear after 10 minutes.

When not using the SAS, enter data in accordance with the following procedure.

1. Press [Main Menu] twice on the LCP.
2. Press the navigation keys to scroll to parameter group 0-\*\* Operation/Display and press [OK].

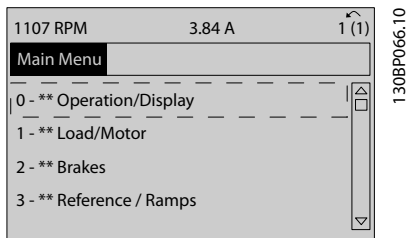

Figure 3.1

3. Press the navigation keys to scroll to parameter group 0-0\* Basic Settings and press [OK].

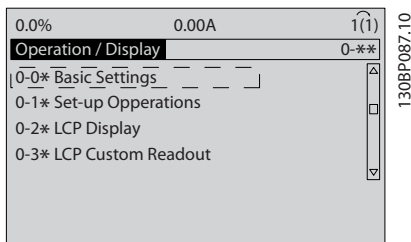

Figure 3.2

4. Press the navigation keys to scroll to 0-03 Regional Settings and press [OK].

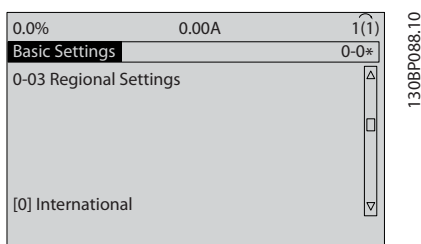

Figure 3.3

5. Press the navigation keys to select *International* or *North America* as appropriate and press [OK]. (This changes the default settings for a number of basic parameters. See 5.5 Parameter Menu Structure for a complete list.)
6. Press [Quick Menu] on the LCP.
7. Press the navigation keys to scroll to parameter group Q2 Quick Set-up and press [OK].

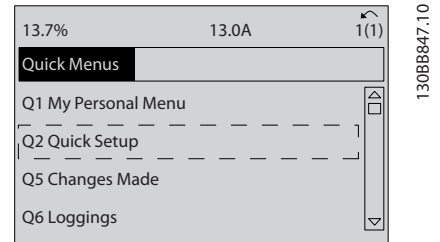

Figure 3.4

8. Select language and press [OK]. Then enter the motor data in 1-20 Motor Power [kW] / 1-21 Motor Power [HP] to 1-25 Motor Nominal Speed. The information can be found on the motor nameplate.

- 1-20 Motor Power [kW] or 1-21 Motor Power [HP]
- 1-22 Motor Voltage
- 1-23 Motor Frequency
- 1-24 Motor Current
- 1-25 Motor Nominal Speed

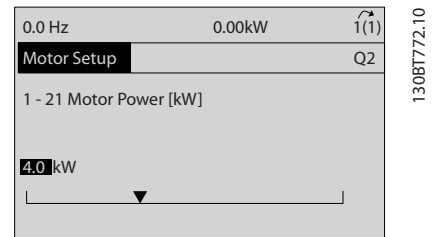

Figure 3.5

9. A jumper wire should be in place between control terminals 12 and 27. If this is the case, leave 5-12 Terminal 27 Digital Input at factory default. Otherwise select *No Operation*. For adjustable frequency drives with an optional bypass, no jumper wire is required.
10. 3-02 Minimum Reference
11. 3-03 Maximum Reference
12. 3-41 Ramp 1 Ramp-up Time
13. 3-42 Ramp 1 Ramp-down Time
14. 3-13 Reference Site. Linked to Hand/Auto\* Local Remote.

This concludes the quick set-up procedure. Press [Status] to return to the operational display.

## 3.4 Local Control Test

**CAUTION****MOTOR START!**

Ensure that the motor, system and any attached equipment are ready for start. It is the responsibility of the user to ensure safe operation under any condition. Failure to ensure that the motor, system, and any attached equipment are ready for start could result in personal injury or equipment damage.

**NOTE!**

The [Hand On] key provides a local start command to the adjustable frequency drive. The [Off] key provides the stop function.

When operating in local mode, [▲] and [▼] increase and decrease the speed output of the adjustable frequency drive. [◀] and [▶] move the display cursor in the numeric display.

1. Press [Hand On].
2. Accelerate the adjustable frequency drive by pressing [▲] to full speed. Moving the cursor left of the decimal point provides quicker input changes.
3. Note any acceleration problems.
4. Press [Off].
5. Note any deceleration problems.

If acceleration problems were encountered

- If warnings or alarms occur, see *8 Warnings and Alarms*
- Check that motor data is entered correctly
- Increase the ramp-up time accel time in *3-41 Ramp 1 Ramp-up Time*
- Increase current limit in *4-18 Current Limit*
- Increase torque limit in *4-16 Torque Limit Motor Mode*

If deceleration problems were encountered

- If warnings or alarms occur, see *8 Warnings and Alarms*.
- Check that motor data is entered correctly.
- Increase the ramp-down time decel time in *3-42 Ramp 1 Ramp-down Time*.
- Enable overvoltage control in *2-17 Over-voltage Control*.

**NOTE!**

The OVC algorithm does not work when using PM motors.

See *4.1.1 Local Control Panel* for resetting the adjustable frequency drive after a trip.

**NOTE!**

*3.2 Applying Power* to *3.3 Basic Operational Programming* conclude the procedures for applying power to the adjustable frequency drive, basic programming, set-up and functional testing.

## 3.5 System startup

The procedure in this section requires user-wiring and application programming to be completed. See *6 Application Examples* for application set-up information. The following procedure is recommended after application set-up by the user is completed.

**CAUTION****MOTOR START!**

Ensure that the motor, system, and any attached equipment are ready for start. It is the responsibility of the user to ensure safe operation under any condition. Failure to do so could result in personal injury or equipment damage.

1. Press [Auto On].
2. Ensure that external control functions are properly wired to the adjustable frequency drive and all programming completed.
3. Apply an external run command.
4. Adjust the speed reference throughout the speed range.
5. Remove the external run command.
6. Note any problem.

If warnings or alarms occur, see *8 Warnings and Alarms*.

## 4 User Interface

### 4.1 Local Control Panel

The local control panel (LCP) is the combined display and keypad on the front of the unit. The LCP is the user interface to the adjustable frequency drive.

The LCP has several user functions.

- Start, stop, and control speed when in local control
- Display operational data, status, warnings and cautions
- Programming adjustable frequency drive functions
- Manually reset the adjustable frequency drive after a fault when auto-reset is inactive

An optional numeric LCP (NLCP) is also available. The NLCP operates in a manner similar to the LCP. See the *Programming Guide* for details on use of the NLCP.

#### 4.1.1 LCP Layout

The LCP is divided into four functional groups (see *Figure 4.1*).

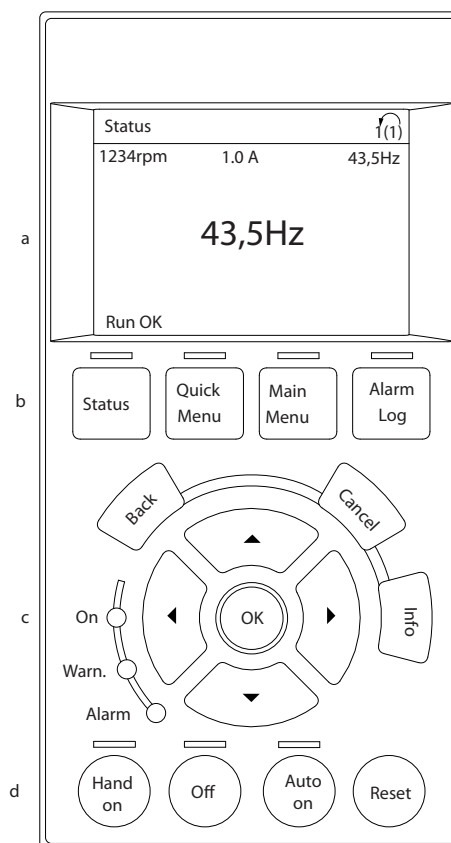

130BC362.10

Figure 4.1 LCP

- Display area.
- Display menu keys for changing the display to show status options, programming, or error message history.
- Navigation keys for programming functions, moving the display cursor, and speed control in local operation. Also included are the status indicator lights.
- Operational mode keys and reset.

### 4.1.2 Setting LCP Display Values

The display area is activated when the adjustable frequency drive receives power from AC line voltage, a DC bus terminal, or an external 24 V DC supply.

The information displayed on the LCP can be customized for user application.

- Each display readout has a parameter associated with it
- Options are selected in the quick menu Q3-13 *Display Settings*
- Display 2 has an alternate larger display option
- The adjustable frequency drive status at the bottom line of the display is generated automatically and is not selectable

Display	Parameter number	Default setting
1.1	0-20	Motor RPMs
1.2	0-21	Motor current
1.3	0-22	Motor power (kW)
2	0-23	Motor frequency
3	0-24	Reference in percent

Table 4.1

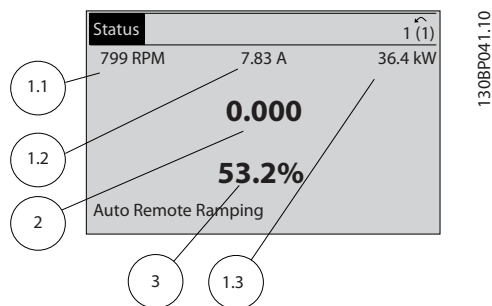

Figure 4.2

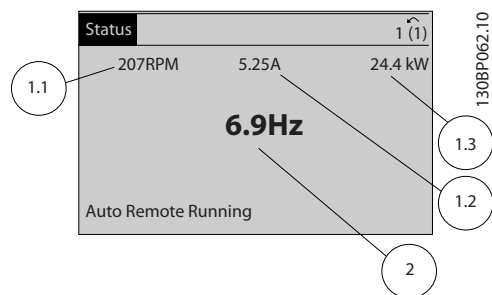

Figure 4.3

### 4.1.3 Display Menu Keys

Menu keys are used for menu access for parameter set-up, toggling through status display modes during normal operation, and viewing fault log data.

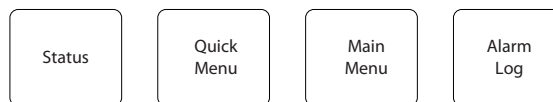

Figure 4.4

130BP045.10

Key	Function
<b>Status</b>	Shows operational information. <ul style="list-style-type: none"> <li>• In auto mode, press to toggle between status readout displays.</li> <li>• Press repeatedly to scroll through each status display.</li> <li>• Press [Status] plus [▲] or [▼] to adjust the display brightness.</li> <li>• The symbol in the upper right corner of the display shows the direction of motor rotation and which set-up is active. This is not programmable.</li> </ul>
<b>Quick Menu</b>	Allows access to programming parameters for initial set-up instructions and many detailed application instructions. <ul style="list-style-type: none"> <li>• Press to access Q2 <i>Quick Setup</i> for sequenced instructions to program the basic frequency controller setup</li> <li>• Follow the sequence of parameters as presented for the function set-up</li> </ul>
<b>Main Menu</b>	Allows access to all programming parameters. <ul style="list-style-type: none"> <li>• Press twice to access top-level index</li> <li>• Press once to return to the last location accessed.</li> <li>• Press to enter a parameter number for direct access to that parameter.</li> </ul>
<b>Alarm Log</b>	Displays a list of current warnings, the last 10 alarms, and the maintenance log. <ul style="list-style-type: none"> <li>• For details about the adjustable frequency drive before it entered the alarm mode, select the alarm number using the navigation keys and press [OK].</li> </ul>

Table 4.2

### 4.1.4 Navigation Keys

Navigation keys are used for programming functions and moving the display cursor. The navigation keys also provide speed control in local (hand) operation. Three adjustable frequency drive status indicators are also located in this area.

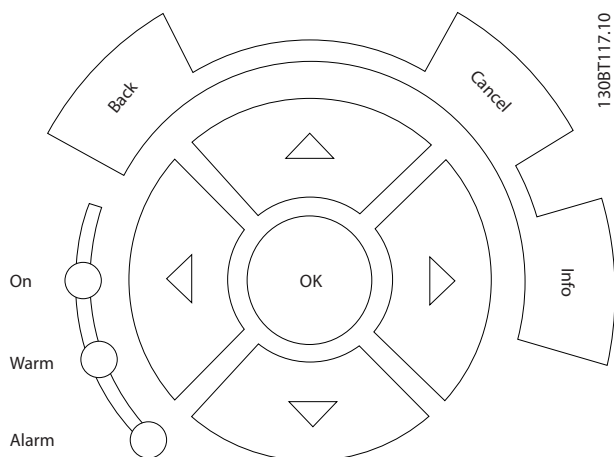

Figure 4.5

Key	Function
<b>Back</b>	Reverts to the previous step or list in the menu structure.
<b>Cancel</b>	Cancels the last change or command as long as the display mode has not changed.
<b>Info</b>	Press for a definition of the function being displayed.
<b>Navigation Keys</b>	Use the four navigation keys to move between items in the menu.
<b>OK</b>	Use to access parameter groups or to enable a choice.

Table 4.3

Light	Indicator	Function
Green	ON	The ON light activates when the adjustable frequency drive receives power from AC line voltage, a DC bus terminal, or an external 24 V supply.
Yellow	WARNING	When warning conditions are met, the yellow WARNING light comes on and text appears in the display area identifying the problem.
Red	ALARM	A fault condition causes the red alarm light to flash and an alarm text is displayed.

Table 4.4

### 4.1.5 Operation Keys

Operation keys are found at the bottom of the LCP.

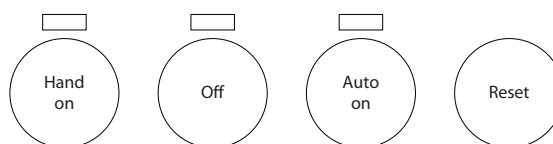

Figure 4.6

Key	Function
<b>Hand On</b>	Starts the adjustable frequency drive in local control. <ul style="list-style-type: none"> <li> Use the navigation keys to control adjustable frequency drive speed.</li> <li> An external stop signal by control input or serial communication overrides the local hand on</li> </ul>
<b>Off</b>	Stops the motor but does not remove power to the adjustable frequency drive.
<b>Auto On</b>	Puts the system in remote operational mode. <ul style="list-style-type: none"> <li> Responds to an external start command by control terminals or serial communication</li> <li> Speed reference is from an external source</li> </ul>
<b>Reset</b>	Resets the adjustable frequency drive manually after a fault has been cleared.

Table 4.5

## 4.2 Back Up and Copying Parameter Settings

Programming data is stored internally in the adjustable frequency drive.

- The data can be uploaded into the LCP memory as a storage backup.
- Once stored in the LCP, the data can be downloaded back into the adjustable frequency drive.
- Data can also be downloaded into other adjustable frequency drives by connecting the LCP into those units and downloading the stored settings. (This is a quick way to program multiple units with the same settings).
- Initialization of the adjustable frequency drive to restore factory default settings does not change data stored in the LCP memory.

## ⚠ WARNING

### UNINTENDED START!

When the adjustable frequency drive is connected to AC line power, the motor may start at any time. The adjustable frequency drive, motor, and any driven equipment must be in operational readiness. Failure to be in operational readiness when the adjustable frequency drive is connected to AC line power could result in death, serious injury, or equipment or property damage.

- Initialization using *14-22 Operation Mode* does not change adjustable frequency drive data such as operating hours, serial communication selections, personal menu settings, fault log, alarm log, and other monitoring functions
- Using *14-22 Operation Mode* is generally recommended.
- Manual initialization erases all motor, programming, localization, and monitoring data and restores factory default settings.

4

#### 4.2.1 Uploading Data to the LCP

1. Press [Off] to stop the motor before uploading or downloading data.
2. Go to *0-50 LCP Copy*.
3. Press [OK].
4. Select *All to LCP*.
5. Press [OK]. A progress bar shows the uploading process.
6. Press [Hand On] or [Auto On] to return to normal operation.

#### 4.2.2 Downloading Data from the LCP

1. Press [Off] to stop the motor before uploading or downloading data.
2. Go to *0-50 LCP Copy*.
3. Press [OK].
4. Select *All from LCP*.
5. Press [OK]. A progress bar shows the downloading process.
6. Press [Hand On] or [Auto On] to return to normal operation.

### 4.3 Restoring Default Settings

## CAUTION

Initialization restores the unit to factory default settings. Any programming, motor data, localization, and monitoring records will be lost. Uploading data to the LCP provides a backup before initialization.

Restoring the adjustable frequency drive parameter settings back to default values is done by initialization of the adjustable frequency drive. Initialization can be through *14-22 Operation Mode* or manually.

#### 4.3.1 Recommended Initialization

1. Press [Main Menu] twice to access parameters.
2. Scroll to *14-22 Operation Mode*.
3. Press [OK].
4. Scroll to *Initialization*.
5. Press [OK].
6. Remove power to the unit and wait for the display to turn off.
7. Apply power to the unit.

Default parameter settings are restored during start-up. This may take slightly longer than normal.

8. Alarm 80 is displayed.
9. Press [Reset] to return to operation mode.

#### 4.3.2 Manual Initialization

1. Remove power to the unit and wait for the display to turn off.
2. Press and hold [Status], [Main Menu], and [OK] at the same time and apply power to the unit.

Factory default parameter settings are restored during startup. This may take slightly longer than normal.

Manual initialization does not the following adjustable frequency drive information.

- *15-00 Operating Hours*
- *15-03 Power-ups*
- *15-04 Over Temps*
- *15-05 Over Volts*



## 5 Programming

### 5.1 Introduction

The adjustable frequency drive is programmed for its application functions using parameters. Parameters are accessed by pressing either [Quick Menu] or [Main Menu] on the LCP. (See 4.1 *Local Control Panel* for details on using the LCP function keys). Parameters may also be accessed through a PC using the MCT 10 Set-up Software (see 5.6.1 *Remote Programming with MCT 10 Set-up Software*).

The quick menu is intended for initial startup (*Q2-\*\* Quick Set-up*) and detailed instructions for common adjustable frequency drive applications (*Q3-\*\* Function Set-up*). Step-by-step instructions are provided. These instructions enable the user to walk through the parameters used for programming applications in their proper sequence. Data entered in a parameter can change the options available in the parameters following that entry. The quick menu presents easy guidelines for getting most systems up and running.

The main menu accesses all parameters and allows for advanced adjustable frequency drive applications.

### 5.2 Programming Example

Here is an example for programming the adjustable frequency drive for a common application in open-loop using the quick menu.

- This procedure programs the adjustable frequency drive to receive a 0–10 V DC analog control signal on input terminal 53
- The adjustable frequency drive will respond by providing 20–50 Hz output to the motor proportional to the input signal (0–10 V DC=20–50 Hz)

This is a common pump or fan application.

Press [Quick Menu] and select the following parameters using the navigation keys to scroll to the titles and press [OK] after each action.

1. *Q3 Function Set-ups*
2. *Parameter Data Set*

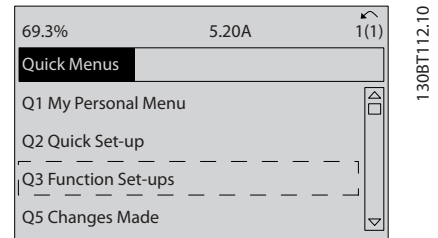

Figure 5.1

3. *Q3-2 Open-loop Settings*

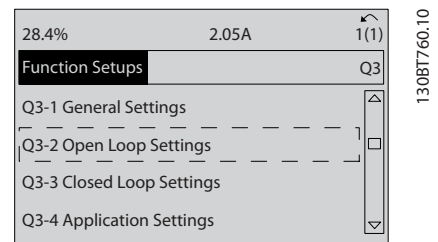

Figure 5.2

4. *Q3-21 Analog Reference*

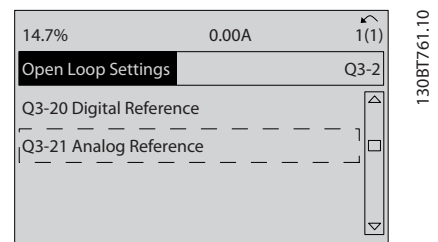

Figure 5.3

5. *3-02 Minimum Reference.* Set minimum internal adjustable frequency drive reference to 0 Hz. (This sets the minimum adjustable frequency drive speed at 0 Hz).

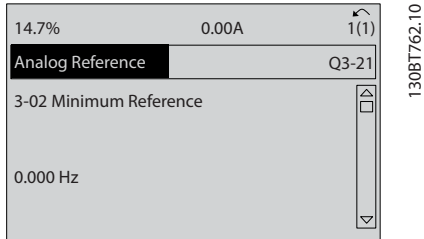

Figure 5.4

6. *3-03 Maximum Reference.* Set maximum internal adjustable frequency drive reference to 60 Hz. (This sets the maximum adjustable frequency drive speed at 60 Hz. Note that 50/60 Hz is a regional variation).

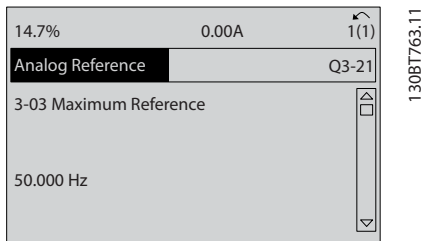

Figure 5.5

7. *6-10 Terminal 53 Low Voltage.* Set minimum external voltage reference on terminal 53 at 0 V. (This sets the minimum input signal at 0 V).

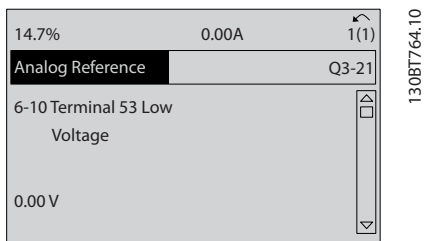

Figure 5.6

8. *6-11 Terminal 53 High Voltage.* Set maximum external voltage reference on terminal 53 at 10 V. (This sets the maximum input signal at 10 V).

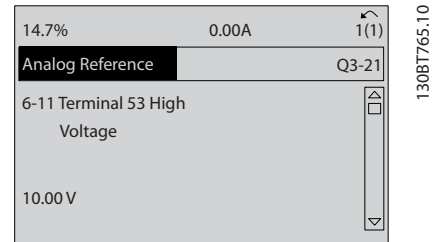

Figure 5.7

9. *6-14 Terminal 53 Low Ref./Feedb. Value.* Set minimum speed reference on terminal 53 at 20 Hz. (This tells the adjustable frequency drive that the minimum voltage received on terminal 53 (0 V) equals 20 Hz output).

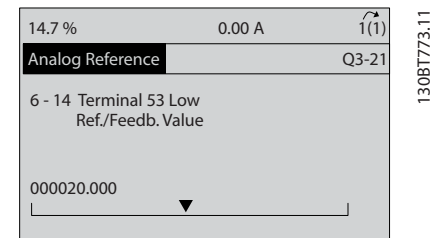

Figure 5.8

10. *6-15 Terminal 53 High Ref./Feedb. Value.* Set maximum speed reference on terminal 53 at 50 Hz. (This tells the adjustable frequency drive that the maximum voltage received on terminal 53 (10 V) equals 50 Hz output).

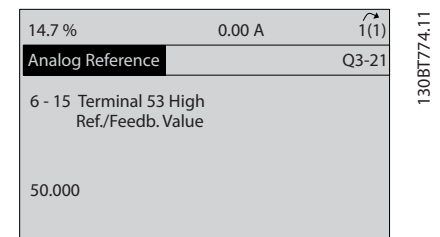

Figure 5.9

With an external device providing a 0–10 V control signal connected to adjustable frequency drive terminal 53, the system is now ready for operation.

**NOTE!**

The scroll bar on the right in the last figure of the display is at the bottom, indicating the procedure is complete.

Figure 5.10 shows the wiring connections used to enable this set-up.

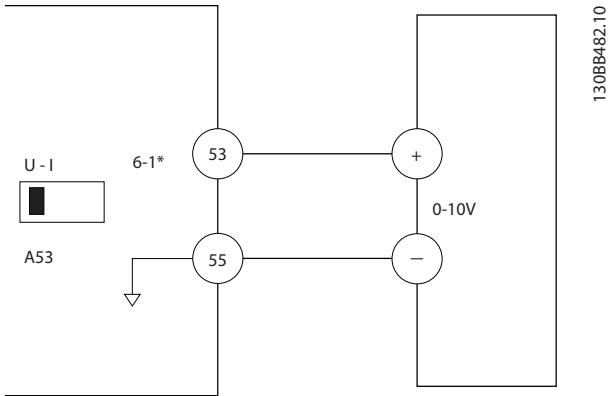

Figure 5.10 Wiring Example for External Device Providing 0–10 V Control Signal

### 5.3 Control Terminal Programming Examples

Control terminals can be programmed.

- Each terminal has specified functions it is capable of performing.
- Parameters associated with the terminal enable the function.
- For proper adjustable frequency drive functioning, the control terminals must be
  - wired properly
  - programmed for the intended function
  - receiving a signal

See Table 5.1 for control terminal parameter number and default setting. (Default setting can change based on the selection in 0-03 Regional Settings).

The following example shows accessing Terminal 18 to see the default setting.

1. Press [Main Menu] twice, scroll to parameter group 5-\*\* Digital In/Out and press [OK].

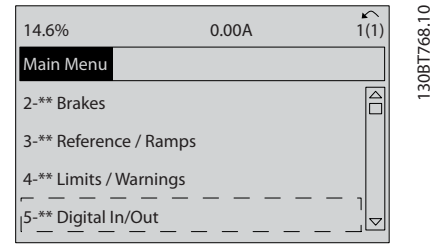

Figure 5.11

2. Scroll to parameter group 5-1\* Digital Inputs and press [OK].

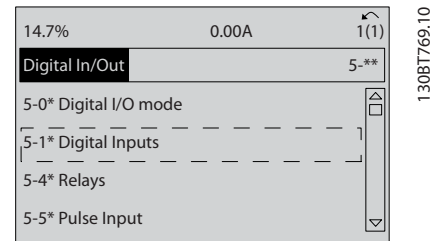

Figure 5.12

3. Scroll to 5-10 Terminal 18 Digital Input. Press [OK] to access function choices. The default setting Start is shown.

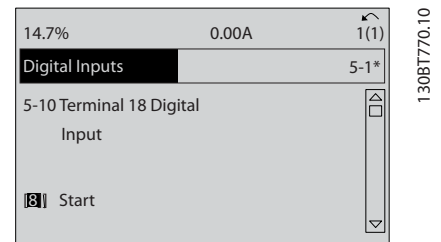

Figure 5.13

### 5.4 International/North American Default Parameter Settings

Setting 0-03 Regional Settings [0] International or [1] North America changes the default settings for some parameters. Table 5.1 lists those parameters that are affected.

Parameter	International default parameter value	North American default parameter value
0-03 Regional Settings	International	North America
0-71 Date Format	DD-MM-YYYY	MM/DD/YYYY
0-72 Time Format	24 h	12 h

Parameter	International default parameter value	North American default parameter value
1-20 Motor Power [kW]	See Note 1	See Note 1
1-21 Motor Power [HP]	See Note 2	See Note 2
1-22 Motor Voltage	230 V/400 V/575 V	208 V/460 V/575 V
1-23 Motor Frequency	50 Hz	60 Hz
3-03 Maximum Reference	50 Hz	60 Hz
3-04 Reference Function	Sum	External/Preset
4-13 Motor Speed High Limit [RPM] See Note 3	1,500 RPM	1,800 RPM
4-14 Motor Speed High Limit [Hz] See Note 4	50 Hz	60 Hz
4-19 Max Output Frequency	100 Hz	120 Hz
4-53 Warning Speed High	1,500 RPM	1,800 RPM
5-12 Terminal 27 Digital Input	Coast inverse	External interlock
5-40 Function Relay	Alarm	No alarm
6-15 Terminal 53 High Ref./Feedb. Value	50	60
6-50 Terminal 42 Output	Speed 0-HighLim	Speed 4-20 mA
14-20 Reset Mode	Manual reset	Infinite auto reset
22-85 Speed at Design Point [RPM] See Note 3	1,500 RPM	1,800 RPM
22-86 Speed at Design Point [Hz]	50 Hz	60 Hz
24-04 Fire Mode Max Reference	50 Hz	60 Hz

minimum and maximum signal ranges, custom displays, automatic restart, and other features.

- See the LCP display to view detailed parameter programming and setting options.
- Press [Info] in any menu location to view additional details for that function.
- Press and hold [Main Menu] to enter a parameter number for direct access to that parameter
- Details for common application set-ups are provided in *6 Application Examples*

**Table 5.1 International/North American Default Parameter Settings**

## 5.5 Parameter Menu Structure

Establishing the correct programming for applications often requires setting functions in several related parameters. These parameter settings provide the adjustable frequency drive with system details it needs to operate properly. System details may include such things as input and output signal types, programming terminals,

5.5.1 Main Menu Structure	1-06 Clockwise Direction	1-75 Start Speed [Hz]	3-10 Preset Reference	4-10 Motor Speed Direction
	1-07 Motor Angle Offset Adjust	1-76 Start Current	3-11 Jog Speed [Hz]	4-11 Motor Speed Low Limit [RPM]
	<b>1-1* Motor Selection</b>	<b>1-8* Stop Adjustments</b>	3-12 Catch up/slow-down Value	4-12 Motor Speed Low Limit [Hz]
	1-10 Motor Construction	1-80 Function at Stop	3-13 Reference Site	4-13 Motor Speed High Limit [RPM]
	1-14 Damping Gain	1-81 Min Speed for Function at Stop [RPM]	3-14 Preset Relative Reference	4-14 Motor Speed High Limit [Hz]
	1-15 Low Speed Filter Time Const.	1-82 Min Speed for Function at Stop [Hz]	3-15 Reference Resource 1	4-16 Torque Limit Motor Mode
	1-16 High Speed Filter Time Const.	1-83 Precise Stop Function	3-16 Reference Resource 2	4-17 Torque Limit Generator Mode
	1-17 Voltage filter time const.	1-84 Precise Stop Counter Value	3-17 Reference Resource 3	4-18 Current Limit
	<b>1-2* Motor Data</b>	1-85 Precise Stop Speed Compensation Delay	3-18 Relative Scaling Reference Resource	4-19 Max Output Frequency
	1-20 Motor Power [kW]	<b>1-9* Motor Temperature</b>	<b>3-4* Ramp 1</b>	<b>Limit Factors</b>
	1-21 Motor Power [HP]	1-90 Motor Thermal Protection	3-40 Ramp 1 Type	Torque Limit Factor Source
	1-22 Motor Voltage	1-91 Motor External Fan	3-41 Ramp 1 Ramp-up Time	Speed Limit Factor Source
	1-23 Motor Frequency	1-92 Motor Nominal Speed	3-42 Ramp 1 Ramp-down Time	<b>Motor Speed Mon.</b>
	1-24 Motor Current	1-93 Thermistor Resource	3-43 Ramp 1 S-ramp Ratio at Accel. Start	Motor Feedback Loss Function
	1-25 Motor Nominal Speed	1-94 ATEX ETR cutlim: speed reduction	3-44 Ramp 1 S-ramp Ratio at Decel. End	Motor Feedback Speed Error
	1-26 Motor Cont. Rated Torque	1-95 KTY sensor Type	3-45 Ramp 1 S-ramp Ratio at Decel. Start	Motor Feedback Loss Timeout
	1-27 Automatic Motor Adaptation (AMA)	1-96 KTY Thermistor Resource	3-46 Ramp 1 S-ramp Ratio at Decel. End	Tracking Error Function
	<b>1-3* Addl. Motor Data</b>	1-97 KTY Threshold level	<b>3-5* Ramp 2</b>	Tracking Error
	1-30 Stator Resistance (Rs)	1-98 ATEX ETR interpol. points freq.	3-50 Ramp 2 Type	Tracking Error Timeout
	1-31 Rotor Resistance (Rr)	1-99 ATEX ETR interpol. points current	3-51 Ramp 2 Ramp-up Time	Tracking Error Ramping
	1-32 Stator Leakage Reactance (Xl)	<b>2-0* Brakes</b>	3-52 Ramp 2 Ramp-down Time	Tracking Error After Ramping
	1-33 Rotor Leakage Reactance (X2)	2-00 DC Hold Current	3-53 Ramp 2 S-ramp Ratio at Accel. Start	Timeout
	1-34 Rotor Leakage Reactance (X2)	2-01 DC Brake Current	3-54 Ramp 2 S-ramp Ratio at Decel. End	<b>4-5* Adj. Warnings</b>
	1-35 Main Reactance (Xh)	2-02 DC Braking Time	3-55 Ramp 2 S-ramp Ratio at Decel. End	Warning Current Low
	1-36 Iron Loss Resistance (Rfe)	2-03 DC Brake Cut-in Speed [RPM]	3-56 Ramp 2 S-ramp Ratio at Decel. End	Warning Current High
	1-37 d-axis Inductance (Ld)	2-04 DC Brake Cut-in Speed [Hz]	3-57 Ramp 2 S-ramp Ratio at Decel. Start	Warning Speed Low
	1-38 Motor Poles	2-05 Maximum Reference	3-58 Ramp 2 S-ramp Ratio at Decel. End	Warning Speed High
	1-39 Motor Poles	2-06 Parking Current	<b>3-6* Ramp 3</b>	Warning Reference Low
	1-40 Back EMF at 1000 RPM	2-07 Parking Time	3-60 Ramp 3 Type	Warning Reference High
	1-41 Motor Angle Offset	<b>2-1* Brake Energy Funct.</b>	3-61 Ramp 3 Ramp-up Time	Warning Feedback Low
	1-42 Max Value of User-defined Readout	2-10 Brake Function	3-62 Ramp 3 Ramp-down Time	Warning Feedback High
	1-43 Display Text 1	2-11 Brake Resistor (ohm)	3-63 Ramp 3 S-ramp Ratio at Accel. Start	Missing Motor Phase Function
	1-44 Display Text 2	2-12 Brake Power Limit (kW)	3-64 Ramp 3 S-ramp Ratio at Decel. End	<b>Speed Bypass</b>
	1-45 Display Text 3	2-13 Brake Power Monitoring	3-65 Ramp 3 S-ramp Ratio at Decel. End	Bypass Speed From [RPM]
	<b>1-5* Load-Indep. Setting</b>	2-14 Brake Check	3-66 Ramp 3 S-ramp Ratio at Decel. End	Bypass Speed From [Hz]
	1-50 Motor Magnetization at Zero Speed [RPM]	2-15 AC brake Max. Current	3-67 Ramp 3 S-ramp Ratio at Decel. Start	Bypass Speed To [RPM]
	1-51 Min Speed Normal Magnetizing [RPM]	2-16 Over-voltage Control	3-68 Ramp 3 S-ramp Ratio at Decel. End	Bypass Speed To [Hz]
	1-52 Min Speed Normal Magnetizing [Hz]	2-17 Over-voltage Control	<b>3-7* Ramp 4</b>	<b>5-0* Digital In/Out</b>
	1-53 Model Shift Frequency	2-18 Brake Check Condition	3-70 Ramp 4 Type	<b>5-0* Digital I/O mode</b>
	1-54 Voltage reduction in fieldweakening	2-19 Over-voltage Gain	3-71 Ramp 4 Ramp-up Time	Digital I/O Mode
	1-55 U/f Characteristic - U	<b>2-2* Mechanical Brake</b>	3-72 Ramp 4 Ramp-down Time	Terminal 27 Mode
	1-56 U/f Characteristic - F	2-20 Release Brake Current	3-73 Ramp 4 S-ramp Ratio at Accel. Start	Terminal 29 Mode
	1-57 Flystart Test Pulses Current	2-21 Activate Brake Speed [RPM]	3-74 Ramp 4 S-ramp Ratio at Accel. End	<b>Digital Inputs</b>
	1-58 Flystart Test Pulses Frequency	2-22 Activate Brake Speed [Hz]	3-75 Ramp 4 S-ramp Ratio at Decel. Start	Terminal 18 Digital Input
	<b>1-6* Load-Depend. Settng.</b>	2-23 Activate Brake Delay	3-76 Ramp 4 S-ramp Ratio at Decel. End	Terminal 19 Digital Input
	1-60 Low Speed Load Compensation	2-24 Stop Delay	3-77 Ramp 4 S-ramp Ratio at Decel. Start	Terminal 27 Digital Input
	1-61 High Speed Load Compensation	2-25 Brake Release Time	3-78 Ramp 4 S-ramp Ratio at Decel. End	Terminal 29 Digital Input
	1-62 Slip Compensation	2-26 Torque Ref	<b>3-8* Other Ramps</b>	Terminal 32 Digital Input
	1-63 Slip Compensation Time Constant	2-27 Torque Ramp Time	3-80 Jog Ramp Time	Terminal 33 Digital Input
	1-64 Resonance Dampening	2-28 Gain Boost Factor	3-81 Quick Stop Ramp Time	Terminal X30/2 Digital Input
	1-65 Resonance Dampening Time Constant	<b>3-0* Reference / Ramps</b>	3-82 Quick Stop Ramp Type	Terminal X30/3 Digital Input
	1-66 Min. Current at Low Speed	<b>3-0* Reference Limits</b>	3-83 Quick Stop S-ramp Ratio at Decel. Start	Terminal X30/4 Digital Input
	1-67 Load Type	3-00 Reference Range	3-84 Quick Stop S-ramp Ratio at Decel. End	Terminal X36/1 Digital Input
	1-68 Minimum Inertia	3-01 Reference/Feedback Unit	<b>3-9* Digital Pot. meter</b>	Terminal X46/3 Digital Input
	1-69 Maximum Inertia	3-02 Minimum Reference	3-90 Step Size	Terminal X46/4 Digital Input
	<b>1-7* Start Adjustments</b>	3-03 Maximum Reference	3-91 Ramp Time	Terminal X46/5 Digital Input
	1-70 PM Start Mode	3-04 Reference Function	3-92 Power Restore	Terminal X46/7 Digital Input
	1-71 Start Delay	<b>3-1* References</b>	3-93 Maximum Limit	Terminal X46/8 Digital Input
	1-72 Start Function	1-00 Configuration Mode	3-94 Minimum Limit	Terminal X46/9 Digital Input
	1-73 Flying Start	1-01 Motor Control Principle	3-95 Ramp Delay	
	1-74 Start Speed [RPM]	1-02 Flux Motor Feedback Source		
		1-03 Torque Characteristics		
		1-04 Overload Mode		
		1-05 Local Mode Configuration		



12-41 Slave Message Count	14-2* Trip Reset	15-30 Fault Log: Error Code	16-25 Torque [Nm] High	17-2* Abs. Enc. Interface
12-42 Slave Exception Message Count	14-20 Reset Mode	15-31 Fault Log: Value	16-3* Drive Status	17-20 Protocol Selection
12-5* EtherCAT	14-21 Automatic Restart Time	15-32 Fault Log: Time	16-30 DC Link Voltage	17-21 Resolution (Positions/Rev)
12-50 Configured Station Alias	14-22 Operation Mode	15-40 FC Type	16-32 Brake Energy /s	17-24 SSI Data Length
12-51 Configured Station Address	14-23 Typecode Setting	15-41 Power Section	16-33 Brake Energy /2 min	17-25 Clock Rate
12-59 EtherCAT Status	14-24 Trip Delay at Current Limit	15-42 Voltage	16-34 Heatsink Temp.	17-26 SSI Data Format
12-8* Oth. Eth. services	14-25 Trip Delay at Torque Limit	15-43 Software Version	16-35 Inverter Thermal	17-34 HIPERFACE Baud rate
12-80 FTP Server	14-26 Trip Delay at Inverter Fault	15-44 Ordered Typecode String	16-36 Inv. Max. Current	17-50 Poles
12-81 HTTP Server	14-28 Production Settings	15-45 Actual Typecode String	16-37 Inv. Max. Current	17-51 Input Voltage
12-82 SMTP Service	14-29 Service Code	15-46 Adj Freq Dr Ordering No.	16-38 SL Controller State	17-52 Input Frequency
12-89 Transparent Socket Channel Port	14-3* Current Limit Ctrl.	15-47 Power Card Ordering No.	16-39 Control Card Temp.	17-53 Transformation Ratio
12-9* Adv. Eth. services	14-30 Current Lim Ctrl, Proportional Gain	15-48 LCP ID Num.	16-40 Logging Buffer Full	17-56 Encoder Sim. Resolution
12-90 Cable Diagnostic	14-31 Current Lim Ctrl, Integration Time	15-49 SW ID Control Card	16-41 LCP Bottom Statusline	17-59 Resolver Interface
12-91 MDI-X	14-32 Current Lim Ctrl, Filter Time	15-50 SW ID Power Card	16-48 Speed Ref. After Ramp [RPM]	17-6* Monitoring and App.
12-92 IGMP Snooping	14-35 Stall Protection	15-51 Adj Freq Dr Serial No.	16-49 Current Fault Source	17-60 Feedback Direction
12-93 Cable Error Length	14-4* Energy Optimizing	15-53 Power Card Serial Number	16-50 External Reference	17-61 Feedback Signal Monitoring
12-94 Broadcast Storm Protection	14-40 VT Level	15-58 Smart Setup Filename	16-51 Pulse Reference	18-** Data Readouts 2
12-95 Broadcast Storm Filter	14-41 AEO Minimum Magnetization	15-59 CSV Filename	16-52 Feedback [Unit]	18-3* Analog Readouts
12-96 Port Config	14-42 Minimum AEO Frequency	15-6* Option Ident	16-53 Digi. Pot Reference	18-36 Analog Input X48/2 [mA]
12-98 Interface Counters	14-43 Motor Cos-Phi	15-60 Option Mounted	16-57 Feedback [RPM]	18-37 Temp. Input X48/4
12-99 Media Counters	14-5* Environment	15-61 Option SW Version	16-60 Digital Input	18-38 Temp. Input X48/7
13-** Smart Logic	14-50 DC 1	15-62 Option Ordering No	16-60 Terminal 53 Switch Setting	18-39 Temp. Input X48/10
13-0* SLC Settings	14-51 Fan Control	15-63 Option Serial No	16-61 Terminal 53 Switch Setting	18-6* Inputs & Outputs 2
13-00 SL Controller Mode	14-52 Fan Monitor	15-70 Option in Slot A	16-62 Analog Input 53	18-60 Digital Input 2
13-01 Start Event	14-53 Output Filter	15-71 Slot A Option SW Version	16-63 Terminal 54 Switch Setting	18-9* PID Readouts
13-02 Stop Event	14-56 Capacitance Output Filter	15-72 Option in Slot B	16-64 Analog Input 54	18-90 Process PID Error
13-03 Reset SLC	14-57 Inductance Output Filter	15-74 Slot B Option SW Version	16-65 Analog Output 42 [mA]	18-91 Process PID Output
13-1* Comparators	14-59 Actual Number of Inverter Units	15-75 Slot C Option SW Version	16-66 Digital Output [bin]	18-92 Process PID Clamped Output
13-10 Comparator Operand	14-7* Compatibility	15-76 Option in Slot C1	16-67 Freq. Input #29 [Hz]	18-93 Process PID Gain Scaled Output
13-11 Comparator Operator	13-12 VLT Alarm Word	15-77 Slot C1 Option SW Version	16-68 Freq. Input #33 [Hz]	30-** Special Features
13-12 Comparator Value	14-72 VLT Warning Word	15-9* Parameter Info	16-69 Pulse Output #27 [Hz]	30-0* Wobbler
13-15 RS-FF Operand S	14-74 VLT Ext. Status Word	15-92 Defined Parameters	16-70 Pulse Output #29 [Hz]	30-00 Wobble Mode
13-16 RS-FF Operand R	14-8* Options	15-93 Modified Parameters	16-71 Relay Output [bin]	30-01 Wobble Delta Frequency [Hz]
13-2* Timers	14-80 Option Supplied by External 24 V DC	15-98 Drive Identification	16-72 Counter A	30-02 Wobble Delta Frequency [%]
13-20 SL Controller Timer	14-89 Option Detection	15-99 Parameter Metadata	16-73 Counter B	30-03 Wobble Delta Freq. Scaling Resource
13-4* Logic Rules	14-9* Fault Settings	16-** Data Readouts	16-74 Prec. Stop Counter	30-04 Wobble Jump Frequency [Hz]
13-40 Logic Rule Boolean 1	14-90 Fault Level	16-0* General Status	16-75 Analog in X30/11	30-05 Wobble Jump Frequency [%]
13-41 Logic Rule Operator 1	15-** Drive Information	16-00 Control Word	16-76 Analog in X30/12	30-06 Wobble Jump Time
13-42 Logic Rule Boolean 2	15-0* Operating Data	16-01 Reference [Unit]	16-77 Analog Out X30/8 [mA]	30-07 Wobble Sequence Time
13-43 Logic Rule Operator 2	15-00 Operating Hours	16-02 Reference %	16-78 Analog Out X45/1 [mA]	30-08 Wobble Up/Down Time
13-44 Logic Rule Boolean 3	15-01 Running Hours	16-03 Status Word	16-79 Analog Out X45/3 [mA]	30-09 Wobble Random Function
13-5* States	15-02 kWh Counter	16-05 Main Actual Value [%]	16-8* Fieldbus & FC Port	30-10 Wobble Ratio
13-51 SL Controller Event	15-03 Power-ups	16-09 Custom Readout	16-80 Fieldbus CTW 1	30-11 Wobble Random Ratio Max.
13-52 SL Controller Action	15-04 Over Temps	16-1* Motor Status	16-82 Fieldbus REF 1	30-12 Wobble Random Ratio Min.
14-** Special Functions	15-05 Over Volts	16-10 Power [kW]	16-84 Comm. Option Status	30-19 Wobble Delta Freq. Scaled
14-0* Inverter Switching	15-06 Reset kWh Counter	16-11 Power [hp]	16-85 FC Port CTW 1	30-2* Adv. Start Adjust
14-00 Switching Pattern	15-07 Reset Running Hours Counter	16-12 Motor voltage	16-86 FC Port REF 1	30-20 High Starting Torque Time [s]
14-01 Switching Frequency	15-1* Data Log Settings	16-13 Frequency	16-87 Comm. Option Status	30-21 High Starting Torque Current [%]
14-03 Overmodulation	15-10 Logging Source	16-14 Motor Current	16-9* Diagnosis Readouts	30-22 Locked Rotor Protection
14-04 PWM Random	15-11 Logging Interval	16-15 Frequency [%]	16-90 Alarm Word	30-23 Compatibility (I)
14-06 Dead Time Compensation	15-12 Trigger Event	16-16 Torque [Nm]	16-91 Alarm word 2	30-80 d-axis inductance (Ld)
14-1* Mains On/Off	15-13 Logging Mode	16-17 Speed [RPM]	16-92 Warning word	30-81 Brake Resistor (ohm)
14-10 Line Failure	15-14 Samples Before Trigger	16-18 Motor Thermal	16-93 Warning word 2	30-83 Speed PID Proportional Gain
14-11 Line Voltage at Line Fault	15-2* Historic Log	16-19 KTY sensor temperature	16-94 Ext. Status Word	30-84 Process PID Proportional Gain
14-12 Function at Mains Imbalance	15-20 Historic Log: Event	16-20 Motor Angle	17-** Feedback Option	31-** Bypass Option
14-13 Line Failure Step Factor	15-21 Historic Log: Value	16-21 Torque [%] High Res.	17-1* Inc. Enc. Interface	31-00 Bypass Mode
14-14 Kin. Backup Time Out	15-22 Historic Log: Time	16-22 Torque [%]	17-10 Signal Type	31-01 Bypass Start Time Delay
14-15 Kin. Backup Trip Recovery Level	15-3* Fault Log		17-11 Resolution (PPR)	

31-02 Bypass Trip Time Delay	32-80 Maximum Velocity (Encoder)	33-54 Terminal X57/5 Digital Input	34-50 Actual Position	42-2* <b>Safe Input</b>
31-03 Test Mode Activation	32-81 Shortest Ramp	33-55 Terminal X57/6 Digital Input	34-51 Commanded Position	42-20 Safe Function
31-10 Bypass Status Word	32-82 Ramp Type	33-56 Terminal X57/7 Digital Input	34-52 Actual Master Position	42-21 Type
31-11 Bypass Running Hours	32-83 Velocity Resolution	33-57 Terminal X57/8 Digital Input	34-53 Slave Index Position	42-22 Discrepancy Time
31-19 Remote Bypass Activation	32-84 Default Velocity	33-58 Terminal X57/9 Digital Input	34-54 Master Index Position	42-23 Stable Signal Time
<b>32** MCO Basic Settings</b>	32-85 Default Acceleration	33-59 Terminal X57/10 Digital Input	34-55 Curve Position	42-24 Restart Behaviour
<b>32-0* Encoder 2</b>	32-86 Acc. up for limited jerk	33-60 Terminal X59/1 and X59/2 Mode	34-56 Track Error	<b>42-3* General</b>
32-00 Incremental Signal Type	32-87 Acc. down for limited jerk	33-61 Terminal X59/1 Digital Input	42-30 External Failure Reaction	42-31 Reset Source
32-01 Incremental Resolution	32-88 Dec. up for limited jerk	33-62 Terminal X59/2 Digital Input	42-31 Reset Source	42-33 Parameter Set Name
32-02 Absolute Protocol	32-89 Dec. down for limited jerk	33-63 Terminal X59/1 Digital Output	42-34 Parameter Set Timestamp	42-35 S-CRC Value
32-03 Absolute Resolution	<b>32-9* Development</b>	33-64 Terminal X59/2 Digital Output	42-36 Level 1 Password	<b>42-4* SSI</b>
32-04 Absolute Encoder Baudrate X55	32-90 Debug Source	33-65 Terminal X59/3 Digital Output	42-40 Type	42-41 Ramp Profile
32-05 Absolute Encoder Data Length	<b>33** MCO Adv. Settings</b>	33-66 Terminal X59/4 Digital Output	42-42 Delay Time	42-43 Delta T
32-06 Absolute Encoder Clock Frequency	<b>33-0* Home Motion</b>	33-67 Terminal X59/5 Digital Output	42-44 Deceleration Rate	42-45 Delta V
32-07 Absolute Encoder Clock Generation	33-00 Force HOME	33-68 Terminal X59/6 Digital Output	42-46 Zero Speed	42-47 Ramp Time
32-08 Absolute Encoder Cable Length	33-01 Zero Point Offset from Home Pos.	33-69 Terminal X59/7 Digital Output	42-48 S-ramp Ratio at Decel. Start	42-49 S-ramp Ratio at Decel. End
32-09 Encoder Monitoring	33-02 Ramp for Home Motion	33-70 Terminal X59/8 Digital Output	<b>42-5* SLS</b>	42-50 Cut Off Speed
32-10 Rotational Direction	33-03 Velocity of Home Motion	<b>33-8* Global Parameters</b>	42-51 Speed Limit	42-52 Fail Safe Reaction
32-11 User Unit Denominator	33-04 Behavior during Home Motion	33-80 Activated Program Number	42-53 Start Ramp	42-54 Ramp Down Time
32-12 User Unit Numerator	<b>33-1* Synchronization</b>	33-81 Power-up State	<b>42-8* Status</b>	42-80 Safe Option Status
32-13 Enc.2 Control	33-10 Synchronization Factor Master (M:5)	33-82 Drive Status Monitoring	42-81 Safe Option Status 2	42-85 Active Safe Func.
32-14 Enc.2 node ID	33-11 Synchronization Factor Slave (M:5)	33-83 Behavior after Esc.	42-86 Safe Option Info	42-89 Customization File Version
32-15 Enc.2 CAN guard	33-12 Position Offset for Synchronization	33-84 Behavior after Esc.	<b>42-9* Special</b>	42-90 Restart Safe Option
<b>32-3* Encoder 1</b>	33-13 Accuracy Window for Position Sync.	33-85 MCO Supplied by External 24VDC		
32-30 Incremental Signal Type	33-14 Relative Slave Velocity Limit	33-86 Terminal at alarm		
32-31 Incremental Resolution	33-15 Marker Number for Master	33-87 Terminal state at alarm		
32-32 Absolute Protocol	33-16 Marker Number for Slave	33-88 Status word at alarm		
32-33 Absolute Resolution	33-17 Master Marker Distance	<b>33-9* MCO Port Settings</b>		
32-35 Absolute Encoder Data Length	33-18 Slave Marker Distance	33-90 X62 MCO CAN node ID		
32-36 Absolute Encoder Clock Frequency	33-19 Master Marker Type	33-91 X62 MCO CAN baud rate		
32-37 Absolute Encoder Clock Generation	33-20 Slave Marker Type	33-94 X60 MCO RS485 serial termination		
32-38 Absolute Encoder Cable Length	33-21 Master Marker Tolerance Window	33-95 X60 MCO RS485 serial baud rate		
32-39 Encoder Monitoring	33-22 Slave Marker Tolerance Window	<b>34** MCO Data Readouts</b>		
32-40 Encoder Termination	33-23 Start Behavior for Marker Sync	<b>34-0* PCD Write Par.</b>		
32-43 Enc.1 Control	33-24 Marker Number for Fault	34-01 PCD 1 Write to MCO		
32-44 Enc.1 node ID	33-25 Marker Number for Ready	34-02 PCD 2 Write to MCO		
32-45 Enc.1 CAN guard	33-26 Velocity Filter	34-03 PCD 3 Write to MCO		
<b>32-5* Feedback Source</b>	33-27 Offset Filter Time	34-04 PCD 4 Write to MCO		
32-50 Source Slave	33-28 Marker Filter Configuration	34-05 PCD 5 Write to MCO		
32-51 MCO 302 Last Will	33-29 Filter Time for Marker Filter	34-06 PCD 6 Write to MCO		
32-52 Source Master	33-30 Maximum Marker Correction	34-07 PCD 7 Write to MCO		
<b>32-6* PID Controller</b>	33-31 Synchronization Type	34-08 PCD 8 Write to MCO		
32-60 Proportional factor	33-32 Feed Forward Velocity Adaptation	34-09 PCD 9 Write to MCO		
32-61 Derivative factor	33-33 Velocity Filter Window	34-10 PCD 10 Write to MCO		
32-62 Integral factor	33-34 Slave Marker filter time	<b>34-2* PCD Read Par.</b>		
32-63 Limit Value for Integral Sum	<b>33-4* Limit Handling</b>	34-21 PCD 1 Read from MCO		
32-64 PID Bandwidth	33-40 Behavior at End Limit Switch	34-22 PCD 2 Read from MCO		
32-65 Velocity Feed-Forward	33-41 Negative Software End Limit	34-23 PCD 3 Read from MCO		
32-66 Acceleration Feed-Forward	33-42 Positive Software End Limit	34-24 PCD 4 Read from MCO		
32-67 Max. Tolerated Position Error	33-43 Negative Software End Limit Active	34-25 PCD 5 Read from MCO		
32-68 Reverse Behavior for Slave	33-44 Positive Software End Limit Active	34-26 PCD 6 Read from MCO		
32-69 Sampling Time for PID Control	33-45 Time in Target Window	34-27 PCD 7 Read from MCO		
32-70 Scan Time for Profile Generator	33-46 Target Window Limit/Value	34-28 PCD 8 Read from MCO		
32-71 Size of the Control Window (Activation)	<b>33-5* I/O Configuration</b>	34-29 PCD 9 Read from MCO		
32-72 Size of the Control Window (Deactiv.)	33-50 Terminal X57/1 Digital Input	34-30 PCD 10 Read from MCO		
32-73 Integral limit filter time	33-51 Terminal X57/2 Digital Input	<b>34-4* Inputs &amp; Outputs</b>		
32-74 Position error filter time	33-52 Terminal X57/3 Digital Input	42-10 Measured Speed Source		
<b>32-8* Velocity &amp; Accel.</b>	33-53 Terminal X57/4 Digital Input	42-11 Encoder Resolution		
		42-12 Encoder Direction		
		42-13 Gear Ratio		
		42-14 Feedback Type		
		42-15 Feedback Filter		
		42-17 Tolerance Error		
		42-18 Zero Speed Timer		
		42-19 Zero Speed Limit		



## 5.6 Remote Programming with MCT 10 Set-up Software

Danfoss has a software program available for developing, storing, and transferring adjustable frequency drive programming. The MCT 10 Set-up Software allows the user to connect a PC to the adjustable frequency drive and perform live programming rather than using the LCP. Additionally, all adjustable frequency drive programming can be done off-line and simply downloaded to the adjustable frequency drive. Or the entire adjustable frequency drive profile can be loaded onto the PC for backup storage or analysis.

The USB connector or RS-485 terminal is available for connecting to the adjustable frequency drive.

MCT 10 Set-up Software is available for free download at [www.VLT-software.com](http://www.VLT-software.com). A CD is also available by requesting part number 130B1000. *The Instruction Manual* provides detailed information on how to program using the MCT 10 Set-up Software.



## 6 Application Examples

### 6.1 Introduction

#### NOTE!

A jumper wire may be required between terminal 12 (or 13) and terminal 37 for the adjustable frequency drive to operate when using factory default programming values.

The examples in this section are intended as a quick reference for common applications.

- Parameter settings are the regional default values unless otherwise indicated (selected in 0-03 Regional Settings)
- Parameters associated with the terminals and their settings are shown next to the drawings.
- Where switch settings for analog terminals A53 or A54 are required, these are also shown.

### 6.2 Application Examples

#### CAUTION

Thermistors must use reinforced or double insulation to meet PELV insulation requirements.

		Parameters	
FC		Function	Setting
+24 V	12		
+24 V	13		
D IN	18		
D IN	19		
COM	20		
D IN	27	1-29 Automatic Motor Adaptation (AMA)	[1] Enable complete AMA
D IN	29	5-12 Terminal 27 Digital Input	[2]* Coast inverse
D IN	32	* = Default Value	
D IN	33	<b>Notes/comments:</b> Parameter group 1-2* Motor Data must be set according to motor	
D IN	37		
+10 V	50		
A IN	53		
A IN	54		
COM	55		
A OUT	42		
COM	39		

Table 6.1 AMA with T27 Connected

		Parameters	
FC		Function	Setting
+24 V	12		
+24 V	13		
D IN	18		
D IN	19		
COM	20		
D IN	27		
D IN	29		
D IN	32		
D IN	33		
D IN	37		
+10 V	50		
A IN	53		
A IN	54		
COM	55		
A OUT	42		
COM	39		

Table 6.2 AMA without T27 Connected

		Parameters	
FC		Function	Setting
+24 V	12		
+24 V	13		
D IN	18		
D IN	19		
COM	20		
D IN	27		
D IN	29		
D IN	32		
D IN	33		
D IN	37		
+10 V	50		
A IN	53	6-10 Terminal 53 Low Voltage	0.07 V*
A IN	54	6-11 Terminal 53 High Voltage	10 V*
COM	55	6-14 Terminal 53 Low Ref./Feedb. Value	0 RPM
A OUT	42	6-15 Terminal 53 High Ref./Feedb. Value	1,500 RPM
COM	39	* = Default Value	
<b>Notes/comments:</b>			

Table 6.3 Analog Speed Reference (Voltage)

		Parameters	
FC		Function	Setting
+24 V	12	6-12 Terminal 53	4 mA*
+24 V	13	Low Current	
D IN	18	6-13 Terminal 53	20 mA*
D IN	19	High Current	
COM	20	6-14 Terminal 53	0 RPM
D IN	27	Low Ref./Feedb. Value	
D IN	29	6-15 Terminal 53	1,500 RPM
D IN	32	High Ref./Feedb. Value	
D IN	33	*=-Default Value	
D IN	37	<b>Notes/comments:</b>	
+10 V	50		
A IN	53		
A IN	54		
COM	55		
A OUT	42		
COM	39		

Table 6.4 Analog Speed Reference (Current)

		Parameters	
FC		Function	Setting
+24 V	12	5-10 Terminal 18	[8] Start*
+24 V	13	Digital Input	
D IN	18	5-12 Terminal 27	[0] No operation
D IN	19	Digital Input	
COM	20	5-19 Terminal 37	[1] Safe Stop Alarm
D IN	27	Digital Input	
D IN	29	*=-Default Value	
D IN	32	<b>Notes/comments:</b>	
D IN	33	If 5-12 Terminal 27 Digital Input is set to [0] No operation, a jumper wire to terminal 27 is not needed.	
D IN	37		
+10	50		
A IN	53		
A IN	54		
COM	55		
A OUT	42		
COM	39		

Table 6.5 Start/Stop Command with Safe Stop

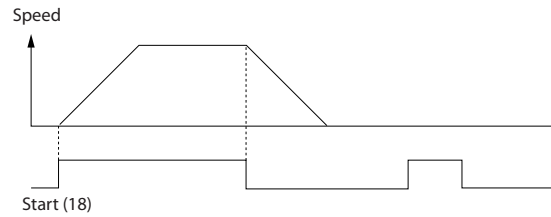

Figure 6.1

		Parameters	
FC		Function	Setting
+24 V	12	5-10 Terminal 18	[9] Latched
+24 V	13	Digital Input	Start
D IN	18	5-12 Terminal 27	[6] Stop
D IN	19	Digital Input	Inverse
COM	20	*=-Default Value	
D IN	27	<b>Notes/comments:</b>	
D IN	29	If 5-12 Terminal 27 Digital Input is set to [0] No operation, a jumper wire to terminal 27 is not needed.	
D IN	32		
D IN	33		
D IN	37		
+10 V	50		
A IN	53		
A IN	54		
COM	55		
A OUT	42		
COM	39		

Table 6.6 Pulse Start/Stop

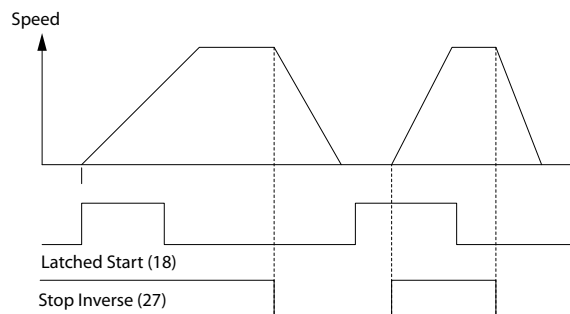

Figure 6.2

		Parameters	
FC		Function	Setting
+24 V	12		
+24 V	13		
D IN	18	5-10 Terminal 18 Digital Input	[8] Start
D IN	19		
COM	20	5-11 Terminal 19 Digital Input	[10] Reversing*
D IN	27		
D IN	29		
D IN	32	5-12 Terminal 27 Digital Input	[0] No operation
D IN	33		
D IN	37		
+10 V	50		
A IN	53		
A IN	54		
COM	55		
A OUT	42		
COM	39		
		3-10 Preset Reference	
		Preset ref. 0	25%
		Preset ref. 1	50%
		Preset ref. 2	75%
		Preset ref. 3	100%
		*=-Default Value	
		<b>Notes/comments:</b>	

Table 6.7 Start/Stop with Reversing and Four Preset Speeds

		Parameters	
FC		Function	Setting
+24 V	12		
+24 V	13		
D IN	18		
D IN	19	5-11 Terminal 19 Digital Input	[1] Reset
COM	20		
D IN	27		
D IN	29		
D IN	32		
D IN	33		
D IN	37		
+10 V	50		
A IN	53		
A IN	54		
COM	55		
A OUT	42		
COM	39		
		*=-Default Value	
		<b>Notes/comments:</b>	

Table 6.8 External Alarm Reset

		Parameters	
FC		Function	Setting
+24 V	12		
+24 V	13		
D IN	18	6-10 Terminal 53 Low Voltage	0.07 V*
D IN	19		
COM	20	6-11 Terminal 53 High Voltage	10 V*
D IN	27		
D IN	29	6-14 Terminal 53 Low Ref./Feedb. Value	0 RPM
D IN	32		
D IN	33		
D IN	37	6-15 Terminal 53 High Ref./Feedb. Value	1,500 RPM
+10 V	50		
A IN	53		
A IN	54		
COM	55		
A OUT	42		
COM	39		
		*=-Default Value	
		<b>Notes/comments:</b>	

Table 6.9 Speed Reference (using a Manual Potentiometer)

		Parameters	
FC		Function	Setting
+24 V	12		
+24 V	13		
D IN	18	5-10 Terminal 18 Digital Input	[8] Start*
D IN	19		
COM	20	5-12 Terminal 27 Digital Input	[19] Freeze Reference
D IN	27		
D IN	29	5-13 Terminal 29 Digital Input	[21] Speed Up
D IN	32		
D IN	33	5-14 Terminal 32 Digital Input	[22] Slow
D IN	37		
+10 V	50		
A IN	53		
A IN	54		
COM	55		
A OUT	42		
COM	39		
		*=-Default Value	
		<b>Notes/comments:</b>	

Table 6.10 Speed Up/Down

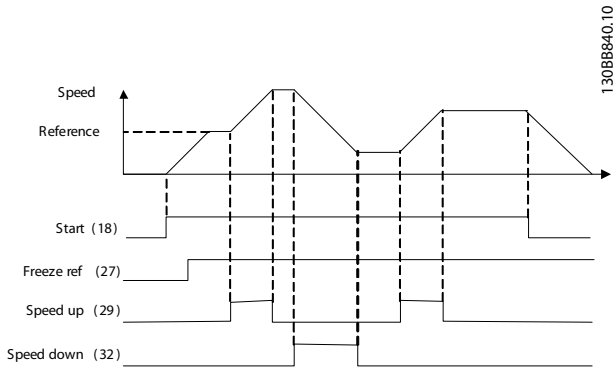

Figure 6.3

6

		Parameters	
		Function	Setting
<b>FC</b>			
+24 V	12○		
+24 V	13○		
D IN	18○	8-30 Protocol	FC*
D IN	19○	8-31 Address	1*
COM	20○	8-32 Baud Rate	9,600*
		*=-Default Value	
<b>Notes/comments:</b>			
Select protocol, address and baud rate in the above mentioned parameters.			
+10 V	50○		
A IN	53○		
A IN	54○		
COM	55○		
A OUT	42○		
COM	39○		
R1	01○ 02○ 03○		
R2	04○ 05○ 06○		
		RS-485	
	61○ 68○ 69○		

Table 6.11 RS-485 Network Connection

		Parameters	
		Function	Setting
<b>FC</b>			
+24 V	12○		
+24 V	13○		
D IN	18○	1-90 Motor Thermal Protection	[2]
D IN	19○		
COM	20○		
D IN	27○	1-93 Thermistor Source	[1] Analog input 53
D IN	29○		
D IN	32○		
D IN	33○		
D IN	37○		
		*=-Default Value	
<b>Notes/comments:</b>			
If only a warning is desired, 1-90 Motor Thermal Protection should be set to [1] Thermistor warning.			
+10 V	50○		
A IN	53○		
A IN	54○		
COM	55○		
A OUT	42○		
COM	39○		
U - I			
A53			

Table 6.12 Motor Thermistor

		Parameters																																																																																	
		Function	Setting																																																																																
<table border="1"> <tr><th colspan="2">FC</th></tr> <tr><td>+24 V</td><td>12</td></tr> <tr><td>+24 V</td><td>13</td></tr> <tr><td>D IN</td><td>18</td></tr> <tr><td>D IN</td><td>19</td></tr> <tr><td>COM</td><td>20</td></tr> <tr><td>D IN</td><td>27</td></tr> <tr><td>D IN</td><td>29</td></tr> <tr><td>D IN</td><td>32</td></tr> <tr><td>D IN</td><td>33</td></tr> <tr><td>D IN</td><td>37</td></tr> <tr><td colspan="2"> </td></tr> <tr><td>+10 V</td><td>50</td></tr> <tr><td>A IN</td><td>53</td></tr> <tr><td>A IN</td><td>54</td></tr> <tr><td>COM</td><td>55</td></tr> <tr><td>A OUT</td><td>42</td></tr> <tr><td>COM</td><td>39</td></tr> <tr><td colspan="2"> </td></tr> <tr><td>R1</td><td>01</td></tr> <tr><td></td><td>02</td></tr> <tr><td></td><td>03</td></tr> <tr><td colspan="2"> </td></tr> <tr><td>R2</td><td>04</td></tr> <tr><td></td><td>05</td></tr> <tr><td></td><td>06</td></tr> </table>		FC		+24 V	12	+24 V	13	D IN	18	D IN	19	COM	20	D IN	27	D IN	29	D IN	32	D IN	33	D IN	37			+10 V	50	A IN	53	A IN	54	COM	55	A OUT	42	COM	39			R1	01		02		03			R2	04		05		06	130B8839.10	<table border="1"> <tr><td>4-30 Motor Feedback Loss Function</td><td>[1] Warning</td></tr> <tr><td>4-31 Motor Feedback Speed Error</td><td>100 RPM</td></tr> <tr><td>4-32 Motor Feedback Loss Timeout</td><td>5 s</td></tr> <tr><td>7-00 Speed PID Feedback Source</td><td>[2] MCB 102</td></tr> <tr><td>17-11 Resolution (PPR)</td><td>1024*</td></tr> <tr><td>13-00 SL Controller Mode</td><td>[1] On</td></tr> <tr><td>13-01 Start Event</td><td>[19] Warning</td></tr> <tr><td>13-02 Stop Event</td><td>[44] Reset key</td></tr> <tr><td>13-10 Comparat or Operand</td><td>[21] Warning no.</td></tr> <tr><td>13-11 Comparat or Operator</td><td>[1] ≈*</td></tr> <tr><td>13-12 Comparat or Value</td><td>90</td></tr> <tr><td>13-51 SL Controller Event</td><td>[22] Comparator 0</td></tr> <tr><td>13-52 SL Controller Action</td><td>[32] Set digital out A low</td></tr> <tr><td>5-40 Function Relay</td><td>[80] SL digital output A</td></tr> </table> <p>*=Default Value</p> <p><b>Notes/comments:</b> If the limit in the feedback monitor is exceeded, Warning 90 will be issued. The SLC monitors Warning 90 and if Warning 90 becomes TRUE, then Relay 1 is triggered. External equipment may then indicate that service may be required. If the feedback error goes below the limit again within 5 sec then the adjustable frequency drive continues and the warning disappears. But Relay 1 will still be triggered until [Reset] on the LCP.</p>	4-30 Motor Feedback Loss Function	[1] Warning	4-31 Motor Feedback Speed Error	100 RPM	4-32 Motor Feedback Loss Timeout	5 s	7-00 Speed PID Feedback Source	[2] MCB 102	17-11 Resolution (PPR)	1024*	13-00 SL Controller Mode	[1] On	13-01 Start Event	[19] Warning	13-02 Stop Event	[44] Reset key	13-10 Comparat or Operand	[21] Warning no.	13-11 Comparat or Operator	[1] ≈*	13-12 Comparat or Value	90	13-51 SL Controller Event	[22] Comparator 0	13-52 SL Controller Action	[32] Set digital out A low	5-40 Function Relay	[80] SL digital output A
FC																																																																																			
+24 V	12																																																																																		
+24 V	13																																																																																		
D IN	18																																																																																		
D IN	19																																																																																		
COM	20																																																																																		
D IN	27																																																																																		
D IN	29																																																																																		
D IN	32																																																																																		
D IN	33																																																																																		
D IN	37																																																																																		
+10 V	50																																																																																		
A IN	53																																																																																		
A IN	54																																																																																		
COM	55																																																																																		
A OUT	42																																																																																		
COM	39																																																																																		
R1	01																																																																																		
	02																																																																																		
	03																																																																																		
R2	04																																																																																		
	05																																																																																		
	06																																																																																		
4-30 Motor Feedback Loss Function	[1] Warning																																																																																		
4-31 Motor Feedback Speed Error	100 RPM																																																																																		
4-32 Motor Feedback Loss Timeout	5 s																																																																																		
7-00 Speed PID Feedback Source	[2] MCB 102																																																																																		
17-11 Resolution (PPR)	1024*																																																																																		
13-00 SL Controller Mode	[1] On																																																																																		
13-01 Start Event	[19] Warning																																																																																		
13-02 Stop Event	[44] Reset key																																																																																		
13-10 Comparat or Operand	[21] Warning no.																																																																																		
13-11 Comparat or Operator	[1] ≈*																																																																																		
13-12 Comparat or Value	90																																																																																		
13-51 SL Controller Event	[22] Comparator 0																																																																																		
13-52 SL Controller Action	[32] Set digital out A low																																																																																		
5-40 Function Relay	[80] SL digital output A																																																																																		

		Parameters																																																																					
		Function	Setting																																																																				
<table border="1"> <tr><th colspan="2">FC</th></tr> <tr><td>+24 V</td><td>12</td></tr> <tr><td>+24 V</td><td>13</td></tr> <tr><td>D IN</td><td>18</td></tr> <tr><td>D IN</td><td>19</td></tr> <tr><td>COM</td><td>20</td></tr> <tr><td>D IN</td><td>27</td></tr> <tr><td>D IN</td><td>29</td></tr> <tr><td>D IN</td><td>32</td></tr> <tr><td>D IN</td><td>33</td></tr> <tr><td>D IN</td><td>37</td></tr> <tr><td colspan="2"> </td></tr> <tr><td>+10 V</td><td>50</td></tr> <tr><td>A IN</td><td>53</td></tr> <tr><td>A IN</td><td>54</td></tr> <tr><td>COM</td><td>55</td></tr> <tr><td>A OUT</td><td>42</td></tr> <tr><td>COM</td><td>39</td></tr> <tr><td colspan="2"> </td></tr> <tr><td>R1</td><td>01</td></tr> <tr><td></td><td>02</td></tr> <tr><td></td><td>03</td></tr> <tr><td colspan="2"> </td></tr> <tr><td>R2</td><td>04</td></tr> <tr><td></td><td>05</td></tr> <tr><td></td><td>06</td></tr> </table>		FC		+24 V	12	+24 V	13	D IN	18	D IN	19	COM	20	D IN	27	D IN	29	D IN	32	D IN	33	D IN	37			+10 V	50	A IN	53	A IN	54	COM	55	A OUT	42	COM	39			R1	01		02		03			R2	04		05		06	130B8841.10	<table border="1"> <tr><td>5-40 Function Relay</td><td>[32] Mech. brake ctrl.</td></tr> <tr><td>5-10 Terminal 18 Digital Input</td><td>[8] Start*</td></tr> <tr><td>5-11 Terminal 19 Digital Input</td><td>[11] Start reversing</td></tr> <tr><td>1-71 Start Delay</td><td>0.2</td></tr> <tr><td>1-72 Start Function</td><td>[5] VVC<sup>plus</sup>/FLUX Clockwise</td></tr> <tr><td>1-76 Start Current</td><td>I<sub>m,n</sub></td></tr> <tr><td>2-20 Release Brake Current</td><td>App. dependent</td></tr> <tr><td>2-21 Activate Brake Speed [RPM]</td><td>Half of nominal slip of the motor</td></tr> </table> <p>*=Default Value</p> <p><b>Notes/comments:</b></p>	5-40 Function Relay	[32] Mech. brake ctrl.	5-10 Terminal 18 Digital Input	[8] Start*	5-11 Terminal 19 Digital Input	[11] Start reversing	1-71 Start Delay	0.2	1-72 Start Function	[5] VVC <sup>plus</sup> /FLUX Clockwise	1-76 Start Current	I <sub>m,n</sub>	2-20 Release Brake Current	App. dependent	2-21 Activate Brake Speed [RPM]	Half of nominal slip of the motor
FC																																																																							
+24 V	12																																																																						
+24 V	13																																																																						
D IN	18																																																																						
D IN	19																																																																						
COM	20																																																																						
D IN	27																																																																						
D IN	29																																																																						
D IN	32																																																																						
D IN	33																																																																						
D IN	37																																																																						
+10 V	50																																																																						
A IN	53																																																																						
A IN	54																																																																						
COM	55																																																																						
A OUT	42																																																																						
COM	39																																																																						
R1	01																																																																						
	02																																																																						
	03																																																																						
R2	04																																																																						
	05																																																																						
	06																																																																						
5-40 Function Relay	[32] Mech. brake ctrl.																																																																						
5-10 Terminal 18 Digital Input	[8] Start*																																																																						
5-11 Terminal 19 Digital Input	[11] Start reversing																																																																						
1-71 Start Delay	0.2																																																																						
1-72 Start Function	[5] VVC <sup>plus</sup> /FLUX Clockwise																																																																						
1-76 Start Current	I <sub>m,n</sub>																																																																						
2-20 Release Brake Current	App. dependent																																																																						
2-21 Activate Brake Speed [RPM]	Half of nominal slip of the motor																																																																						

Table 6.14 Mechanical Brake Control

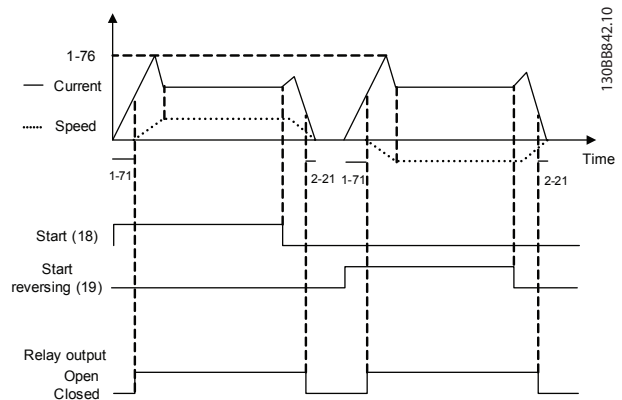

Figure 6.4

Table 6.13 Using SLC to Set a Relay





## 7 Status Messages

### 7.1 Status Display

When the adjustable frequency drive is in status mode, status messages are generated automatically from within the adjustable frequency drive and appear in the bottom line of the display (see *Figure 7.1.*)

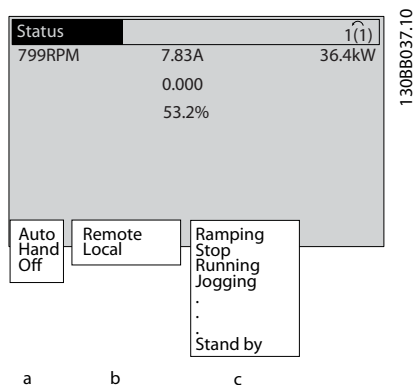

Figure 7.1 Status Display

- The first part of the status line indicates where the stop/start command originates.
- The second part of the status line indicates where the speed control originates.
- The last part of the status line gives the present adjustable frequency drive status. These show the operational mode the adjustable frequency drive is in.

#### NOTE!

In auto/remote mode, the adjustable frequency drive requires external commands to execute functions.

### 7.2 Status Message Definitions Table

The next three tables define the meaning of the status message display words.

Off	The adjustable frequency drive does not react to any control signal until [Auto On] or [Hand On] is pressed.
Auto on	The adjustable frequency drive is controlled from the control terminals and/or the serial communication.
Hand on	The adjustable frequency drive can be controlled by the navigation keys on the LCP. Stop commands, reset, reversing, DC brake, and other signals applied to the control terminals can override local control.

Table 7.1 Operation Mode

Remote	The speed reference is given from external signals, serial communication, or internal preset references.
Local	The adjustable frequency drive uses [Hand On] control or reference values from the LCP.

Table 7.2 Reference Site

AC Brake	AC Brake was selected in 2-10 Brake Function. The AC brake over-magnetizes the motor to achieve a controlled slow down.
AMA finish OK	Automatic motor adaptation (AMA) was carried out successfully.
AMA ready	AMA is ready to start. Press [Hand On] to start.
AMA running	AMA process is in progress.
Braking	The brake chopper is in operation. Generative energy is absorbed by the brake resistor.
Braking max.	The brake chopper is in operation. The power limit for the brake resistor defined in 2-12 Brake Power Limit (kW) is reached.
Coast	<ul style="list-style-type: none"> <li>Coast inverse was selected as a function for a digital input (parameter group 5-1* Digital Inputs). The corresponding terminal is not connected.</li> <li>Coast activated by serial communication</li> </ul>

Ctrl. Ramp-down	Control Ramp-down was selected in <i>14-10 Mains Failure</i> . <ul style="list-style-type: none"> <li>The AC line voltage is below the value set in <i>14-11 Mains Voltage at Mains Fault</i> at line power fault.</li> <li>The adjustable frequency drive ramps down the motor using a controlled ramp-down.</li> </ul>
Current High	The adjustable frequency drive output current is above the limit set in <i>4-51 Warning Current High</i> .
Current Low	The adjustable frequency drive output current is below the limit set in <i>4-52 Warning Speed Low</i> .
DC Hold	DC hold is selected in <i>1-80 Function at Stop</i> and a stop command is active. The motor is held by a DC current set in <i>2-00 DC Hold/ Preheat Current</i> .
DC Stop	The motor is held with a DC current ( <i>2-01 DC Brake Current</i> ) for a specified time ( <i>2-02 DC Braking Time</i> ). <ul style="list-style-type: none"> <li>DC Brake is activated in <i>2-03 DC Brake Cut-in Speed [RPM]</i> and a Stop command is active</li> <li>DC Brake (inverse) is selected as a function for a digital input (parameter group <i>5-1* Digital Inputs</i>). The corresponding terminal is not active.</li> <li>The DC Brake is activated via serial communication</li> </ul>
Feedback high	The sum of all active feedbacks is above the feedback limit set in <i>4-57 Warning Feedback High</i> .
Feedback low	The sum of all active feedbacks is below the feedback limit set in <i>4-56 Warning Feedback Low</i> .
Freeze output	The remote reference is active, which holds the present speed. <ul style="list-style-type: none"> <li>Freeze output was selected as a function for a digital input (parameter group <i>5-1* Digital Inputs</i>). The corresponding terminal is active. Speed control is only possible via the terminal functions speed up and slow.</li> <li>Hold ramp is activated via serial communication</li> </ul>
Freeze output request	A freeze output command has been given, but the motor will remain stopped until a run permissive signal is received.

Freeze ref.	<i>Freeze Reference</i> was chosen as a function for a digital input (parameter group <i>5-1* Digital Inputs</i> ). The corresponding terminal is active. The adjustable frequency drive saves the actual reference. Changing the reference is now only possible via terminal functions speed up and slow.
Jog request	A jog command has been given, but the motor will be stopped until a run permissive signal is received via a digital input.
Jogging	The motor is running as programmed in <i>3-19 Jog Speed [RPM]</i> . <ul style="list-style-type: none"> <li><i>Jog</i> was selected as function for a digital input (parameter group <i>5-1* Digital Inputs</i>). The corresponding terminal (e.g., Terminal 29) is active.</li> <li>The Jog function is activated via the serial communication</li> <li>The Jog function was selected as a reaction for a monitoring function (e.g., No signal). The monitoring function is active</li> </ul>
Motor check	In <i>1-80 Function at Stop, Motor Check</i> was selected. A stop command is active. To ensure that a motor is connected to the adjustable frequency drive, a permanent test current is applied to the motor.
OVC control	<i>Overvoltage Control</i> was activated in <i>2-17 Overvoltage Control</i> . The connected motor is supplying the adjustable frequency drive with generative energy. The overvoltage control adjusts the V/Hz ratio to run the motor in controlled mode and to prevent the adjustable frequency drive from tripping.
PowerUnit Off	(For adjustable frequency drives with an external 24 V power supply installed only). Line power supply to the adjustable frequency drive is removed, but the control card is supplied by the external 24 V.
Protection md	Protection mode is active. The unit has detected a critical status (an overcurrent or overvoltage). <ul style="list-style-type: none"> <li>To avoid tripping, switching frequency is reduced to 4 kHz</li> <li>If possible, Protection mode ends after approximately 10 s</li> <li>Protection mode can be restricted in <i>14-26 Trip Delay at Inverter Fault</i></li> </ul>

QStop	<p>The motor is decelerating using 3-81 <i>Quick Stop Ramp Time</i>.</p> <ul style="list-style-type: none"> <li>• <i>Quick stop inverse</i> was chosen as a function for a digital input (parameter group 5-1* <i>Digital Inputs</i>). The corresponding terminal is not active.</li> <li>• The quick stop function was activated via serial communication</li> </ul>
Ramping	The motor is accelerating/decelerating using the active ramp-up/down. The reference, a limit value or a standstill is not yet reached.
Ref. high	The sum of all active references is above the reference limit set in 4-55 <i>Warning Reference High</i> .
Ref. low	The sum of all active references is below the reference limit set in 4-54 <i>Warning Reference Low</i> .
Run on ref.	The adjustable frequency drive is running in the reference range. The feedback value matches the setpoint value.
Run request	A start command has been given, but the motor is stopped until a run permissive signal is received via digital input.
Running	The motor is driven by the adjustable frequency drive.
Speed high	Motor speed is above the value set in 4-53 <i>Warning Speed High</i> .
Speed low	Motor speed is below the value set in 4-52 <i>Warning Speed Low</i> .
Standby	In Auto On Auto mode, the adjustable frequency drive will start the motor with a start signal from a digital input or serial communication.
Start delay	In 1-71 <i>Start Delay</i> , a delay starting time was set. A start command is activated and the motor will start after the start delay time expires.
Start fwd/rev	Start forward and start reverse were selected as functions for two different digital inputs (parameter group 5-1* <i>Digital Inputs</i> ). The motor will start in forward or reverse depending on which corresponding terminal is activated.
Stop	The adjustable frequency drive has received a stop command from the LCP, digital input or serial communication.
Trip	An alarm occurred and the motor is stopped. Once the cause of the alarm is cleared, the adjustable frequency drive can be reset manually by pressing [Reset] or remotely by control terminals or serial communication.

Trip lock	<p>An alarm occurred and the motor is stopped. Once the cause of the alarm is cleared, power must be cycled to the adjustable frequency drive. The adjustable frequency drive can then be reset manually by pressing [Reset] or remotely by control terminals or serial communication.</p>
-----------	--

**Table 7.3 Operation Status**



## 8 Warnings and Alarms

### 8.1 System Monitoring

The adjustable frequency drive monitors the condition of its input power, output, and motor factors as well as other system performance indicators. A warning or alarm may not necessarily indicate a problem internal to the adjustable frequency drive itself. In many cases, it indicates failure conditions from input voltage, motor load or temperature, external signals, or other areas monitored by the adjustable frequency drive's internal logic. Be sure to investigate those areas exterior to the adjustable frequency drive as indicated in the alarm or warning.

### 8.2 Warning and Alarm Types

#### 8.2.1 Warnings

A warning is issued when an alarm condition is impending or when an abnormal operating condition is present and may result in the adjustable frequency drive issuing an alarm. A warning clears by itself when the abnormal condition is removed.

#### 8.2.2 Alarm Trip

An alarm is issued when the adjustable frequency drive is tripped, that is, the adjustable frequency drive suspends operation to prevent adjustable frequency drive or system damage. The motor will coast to a stop. The adjustable frequency drive logic will continue to operate and monitor the adjustable frequency drive status. After the fault condition is remedied, the adjustable frequency drive can be reset. It will then be ready to start operation again.

A trip can be reset in any of 4 ways:

- Press [Reset] on the LCP
- Digital reset input command
- Serial communication reset input command
- Auto reset

#### 8.2.3 Alarm Trip Lock

An alarm that causes the adjustable frequency drive to trip-lock requires that input power be cycled. The motor will coast to a stop. The adjustable frequency drive logic will continue to operate and monitor the adjustable frequency drive status. Remove input power to the adjustable frequency drive and correct the cause of the fault, then restore power. This action puts the adjustable frequency drive into a trip condition as described above and may be reset in any of those four ways.

### 8.3 Warning and Alarm Displays

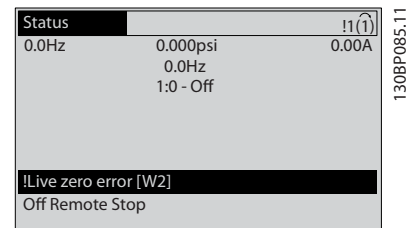

Figure 8.1

An alarm or trip lock alarm will flash on display along with the alarm number.

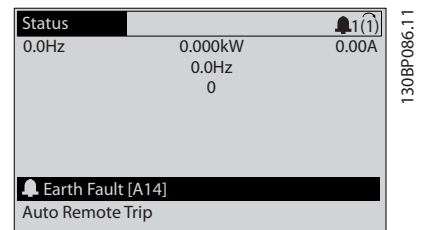

Figure 8.2

In addition to the text and alarm code on the adjustable frequency drive display, there are three status indicator lights.

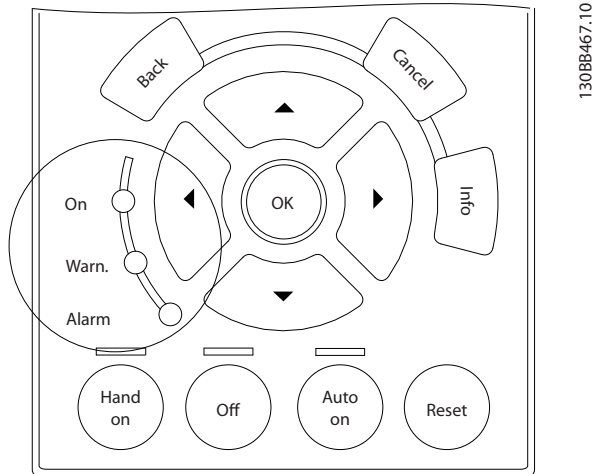

Figure 8.3

8

	Warn. LED	Alarm LED
Warning	ON	OFF
Alarm	OFF	ON (Flashing)
Trip Lock	ON	ON (Flashing)

Table 8.1

## 8.4 Warning and Alarm Definitions

### CAUTION

Before applying power to the unit, inspect the entire installation as detailed in *Table 3.1*. Check mark those items when completed.

Inspect for	Description	<input checked="" type="checkbox"/>
Auxiliary equipment	<ul style="list-style-type: none"> <li>Look for auxiliary equipment, switches, disconnects, or input fuses/circuit breakers that may reside on the input power side of the adjustable frequency drive or output side to the motor. Ensure that they are ready for full speed operation.</li> <li>Check function and installation of any sensors used for feedback to the adjustable frequency drive</li> <li>Remove power factor correction caps on motor(s), if present</li> </ul>	
Cable routing	<ul style="list-style-type: none"> <li>Ensure that input power, motor wiring, and control wiring are separated or in three separate metallic conduits for high frequency noise isolation</li> </ul>	
Control wiring	<ul style="list-style-type: none"> <li>Check for broken or damaged wires and loose connections.</li> <li>Check that control wiring is isolated from power and motor wiring for noise immunity.</li> <li>Check the voltage source of the signals, if necessary.</li> <li>The use of shielded cable or twisted pair is recommended. Ensure that the shield is terminated correctly</li> </ul>	
Cooling clearance	<ul style="list-style-type: none"> <li>Make sure that the top and bottom clearance is adequate to ensure proper airflow for cooling.</li> </ul>	
EMC considerations	<ul style="list-style-type: none"> <li>Check for proper installation regarding electromagnetic compatibility.</li> </ul>	
Environmental considerations	<ul style="list-style-type: none"> <li>See equipment label for the maximum ambient operating temperature limits</li> <li>Humidity levels must be 5%–95% non-condensing.</li> </ul>	
Fusing and circuit breakers	<ul style="list-style-type: none"> <li>Check for proper fusing or circuit breakers.</li> <li>Check that all fuses are inserted firmly and in operational condition and that all circuit breakers are in the open position</li> </ul>	
Grounding	<ul style="list-style-type: none"> <li>The unit requires a ground wire from its chassis to the building ground</li> <li>Check for good ground connections that are tight and free of oxidation</li> <li>Grounding to conduit or mounting the back panel to a metal surface is not a suitable ground</li> </ul>	
Input and output power wiring	<ul style="list-style-type: none"> <li>Check for loose connections.</li> <li>Check that motor and line power are in separate conduit or separated shielded cables.</li> </ul>	
Panel interior	<ul style="list-style-type: none"> <li>Make sure that the unit interior is free of dirt, metal chips, moisture, and corrosion.</li> </ul>	
Switches	<ul style="list-style-type: none"> <li>Ensure that all switch and disconnect settings are in the proper positions</li> </ul>	
Vibration	<ul style="list-style-type: none"> <li>Check that the unit is mounted solidly or that shock mounts are used, as necessary.</li> <li>Check for an unusual amount of vibration</li> </ul>	

Table 8.2 Start-up Check List

## 8.5 Fault Messages

The warning/alarm information below defines each warning/alarm condition, provides the probable cause for the condition, and details a remedy or troubleshooting procedure.

### WARNING 1, 10 Volts low

The control card voltage is below 10 V from terminal 50. Remove some of the load from terminal 50, as the 10 V supply is overloaded. Max. 15 mA or minimum 590 Ω.

This condition can be caused by a short in a connected potentiometer or improper wiring of the potentiometer.

#### Troubleshooting

Remove the wiring from terminal 50. If the warning clears, the problem is with the customer wiring. If the warning does not clear, replace the control card.

### WARNING/ALARM 2, Live zero error

This warning or alarm only appears if programmed by the user in *6-01 Live Zero Timeout Function*. The signal on one of the analog inputs is less than 50% of the minimum value programmed for that input. Broken wiring or faulty device sending the signal can cause this condition.

#### Troubleshooting

- Check connections on all the analog input terminals. Control card terminals 53 and 54 for signals, terminal 55 common. MCB 101 terminals 11 and 12 for signals, terminal 10 common. MCB 109 terminals 1, 3, 5 for signals, terminals 2, 4, 6 common).
- Check that the adjustable frequency drive programming and switch settings match the analog signal type
- Perform Input Terminal Signal Test

### WARNING/ALARM 3, No motor

No motor has been connected to the output of the adjustable frequency drive.

### WARNING/ALARM 4, Mains phase loss

A phase is missing on the supply side, or the line voltage imbalance is too high. This message also appears for a fault in the input rectifier on the adjustable frequency drive. Options are programmed at *14-12 Function at Mains Imbalance*.

#### Troubleshooting

Check the supply voltage and supply currents to the adjustable frequency drive.

### WARNING 5, DC link voltage high

The intermediate circuit voltage (DC) is higher than the high voltage warning limit. The limit is dependent on the adjustable frequency drive voltage rating. The unit is still active.

### WARNING 6, DC link voltage low

The intermediate circuit voltage (DC) is lower than the low voltage warning limit. The limit is dependent on the adjustable frequency drive voltage rating. The unit is still active.

### WARNING/ALARM 7, DC overvoltage

If the intermediate circuit voltage exceeds the limit, the adjustable frequency drive trips after a time.

#### Troubleshooting

- Connect a brake resistor
- Extend the ramp time
- Change the ramp type
- Activate the functions in *2-10 Brake Function*
- Increase *14-26 Trip Delay at Inverter Fault*

### WARNING/ALARM 8, DC undervoltage

If the intermediate circuit voltage (DC link) drops below the under voltage limit, the adjustable frequency drive checks if a 24 V DC backup supply is connected. If no 24 V DC backup supply is connected, the adjustable frequency drive trips after a fixed time delay. The time delay varies with unit size.

#### Troubleshooting

- Make sure that the supply voltage matches the adjustable frequency drive voltage.
- Perform input voltage test.
- Perform soft charge circuit test.

### WARNING/ALARM 9, Inverter overload

The adjustable frequency drive is about to cut out because of an overload (too high current for too long). The counter for electronic, thermal inverter protection gives a warning at 98% and trips at 100%, while giving an alarm. The adjustable frequency drive *cannot* be reset until the counter is below 90%.

The fault is that the adjustable frequency drive is overloaded by more than 100% for too long.

#### Troubleshooting

- Compare the output current shown on the LCP with the adjustable frequency drive rated current
- Compare the output current shown on the LCP with measured motor current
- Display the Thermal Drive Load on the LCP and monitor the value. When running above the adjustable frequency drive continuous current rating, the counter should increase. When running below the adjustable frequency drive continuous current rating, the counter should decrease



**WARNING/ALARM 10, Motor overload temperature**

According to the electronic thermal protection (ETR), the motor is too hot. Select whether the adjustable frequency drive gives a warning or an alarm when the counter reaches 100% in *1-90 Motor Thermal Protection*. The fault occurs when the motor is overloaded by more than 100% for too long.

**Troubleshooting**

- Check for motor overheating
- Check if the motor is mechanically overloaded.
- Check that the motor current set in *1-24 Motor Current* is correct
- Ensure that Motor data in parameters 1-20 through 1-25 are set correctly
- If an external fan is in use, check in *1-91 Motor External Fan* that it is selected
- Running AMA in *1-29 Automatic Motor Adaptation (AMA)* tunes the adjustable frequency drive to the motor more accurately and reduces thermal loading

**WARNING/ALARM 11, Motor thermistor overtemp**

The thermistor might be disconnected. Select whether the adjustable frequency drive gives a warning or an alarm in *1-90 Motor Thermal Protection*.

**Troubleshooting**

- Check for motor overheating
- Check if the motor is mechanically overloaded.
- Check that the thermistor is connected correctly between either terminal 53 or 54 (analog voltage input) and terminal 50 (+10 V supply) and that the terminal switch for 53 or 54 is set for voltage. Check *1-93 Thermistor Source* selects terminal 53 or 54
- When using digital inputs 18 or 19, check that the thermistor is connected correctly between either terminal 18 or 19 (digital input PNP only) and terminal 50
- If a KTY sensor is used, check for correct connection between terminals 54 and 55
- If using a thermal switch or thermistor, check that the programming of *1-93 Thermistor Resource* matches sensor wiring
- If using a KTY sensor, check the programming of *1-95 KTY Sensor Type*, *1-96 KTY Thermistor Resource*, and *1-97 KTY Threshold level match sensor wiring*

**WARNING/ALARM 12, Torque limit**

The torque has exceeded the value in *4-16 Torque Limit Motor Mode* or the value in *4-17 Torque Limit Generator Mode*. *14-25 Trip Delay at Torque Limit* can change this from a warning only condition to a warning followed by an alarm.

**Troubleshooting**

- If the motor torque limit is exceeded during ramp-up, extend the ramp-up time
- If the generator torque limit is exceeded during ramp-down, extend the ramp-down time
- If torque limit occurs while running, possibly increase the torque limit. Be sure the system can operate safely at a higher torque
- Check the application for excessive current draw on the motor

**WARNING/ALARM 13, Overcurrent**

The inverter peak current limit (approximately 200% of the rated current) is exceeded. The warning lasts about 1.5 s, then the adjustable frequency drive trips and issues an alarm. This fault may be caused by shock loading or fast acceleration with high inertia loads. If extended mechanical brake control is selected, trip can be reset externally.

**Troubleshooting**

- Remove power and check if the motor shaft can be turned
- Check that the motor size matches the adjustable frequency drive
- Check parameters 1-20 to 1-25 for correct motor data

**ALARM 14, Ground fault**

There is current from the output phases to ground, either in the cable between the adjustable frequency drive and the motor or in the motor itself.

**Troubleshooting:**

- Remove power to the adjustable frequency drive and repair the ground fault
- Check for ground faults in the motor by measuring the resistance to ground of the motor leads and the motor with a megohmmeter
- Perform current sensor test

**ALARM 15, Hardware mismatch**

A fitted option is not operational with the present control board hardware or software.

Record the value of the following parameters and contact the Danfoss supplier:

- *15-40 FC Type*
- *15-41 Power Section*

- 15-42 Voltage
- 15-43 Software Version
- 15-45 Actual Typecode String
- 15-49 SW ID Control Card
- 15-50 SW ID Power Card
- 15-60 Option Mounted
- 15-61 Option SW Version (for each option slot)

**ALARM 16, Short-circuit**

There is short-circuiting in the motor or motor wiring.

Remove power to the adjustable frequency drive and repair the short circuit.

**WARNING/ALARM 17, Control word timeout**

There is no communication to the adjustable frequency drive.

The warning will only be active when 8-04 Control Timeout Function is NOT set to OFF.

If 8-04 Control Timeout Function is set to Stop and Trip, a warning appears and the adjustable frequency drive ramps down until it trips then displays an alarm.

**Troubleshooting:**

- Check connections on the serial communication cable
- Increase 8-03 Control Timeout Time
- Check the operation of the communication equipment
- Verify a proper installation based on EMC requirements

**WARNING/ALARM 22, Hoist mechanical brake**

Report value shows what kind it is.

0 = The torque ref. was not reached before timeout.

1 = There was no brake feedback before timeout.

**WARNING 23, Internal fan fault**

The fan warning function is an extra protective function that checks if the fan is running/mounted. The fan warning can be disabled in 14-53 Fan Monitor ([0] Disabled).

**Troubleshooting**

- Check fan resistance
- Check soft charge fuses

**WARNING 24, External fan fault**

The fan warning function is an extra protective function that checks if the fan is running/mounted. The fan warning can be disabled in 14-53 Fan Monitor ([0] Disabled).

**Troubleshooting**

- Check fan resistance
- Check soft charge fuses

**WARNING 25, Brake resistor short-circuit**

The brake resistor is monitored during operation. If a short circuit occurs, the brake function is disabled and the warning appears. The adjustable frequency drive is still operational but without the brake function. Remove power to the adjustable frequency drive and replace the brake resistor (see 2-15 Brake Check).

**WARNING/ALARM 26, Brake resistor power limit**

The power transmitted to the brake resistor is calculated as a mean value over the last 120 s of run time. The calculation is based on the intermediate circuit voltage and the brake resistance value set in 2-16 AC Brake Max. Current. The warning is active when the dissipated braking is higher than 90% of the brake resistance power. If [2] Trip is selected in 2-13 Brake Power Monitoring, the adjustable frequency drive will trip when the dissipated braking energy reaches 100%.



**There is a risk of substantial power being transmitted to the brake resistor if the brake transistor is short-circuited.**

**WARNING/ALARM 27, Brake chopper fault**

The brake transistor is monitored during operation and if a short circuit occurs, the brake function is disabled and a warning is issued. The adjustable frequency drive is still operational but, since the brake transistor has short-circuited, substantial power is transmitted to the brake resistor, even if it is inactive.

Remove power to the adjustable frequency drive and remove the brake resistor.

This alarm/warning could also occur should the brake resistor overheat. Terminals 104 and 106 are available as brake resistors Klixon inputs, see Brake Resistor Temperature Switch in the Design Guide.

**WARNING/ALARM 28, Brake check failed**

The brake resistor is not connected or not working. Check 2-15 Brake Check.

**ALARM 29, Heatsink temp**

The maximum temperature of the heatsink has been exceeded. The temperature fault will not reset until the temperature falls below a defined heatsink temperature. The trip and reset points are different based on the adjustable frequency drive power size.

**Troubleshooting**

Check for the following conditions

- Ambient temperature too high
- Motor cable too long
- Incorrect airflow clearance above and below the adjustable frequency drive

- Blocked airflow around the adjustable frequency drive
- Damaged heatsink fan
- Dirty heatsink

This alarm is based on the temperature measured by the heatsink sensor mounted inside the IGBT modules

**Troubleshooting**

- Check fan resistance
- Check soft charge fuses
- IGBT thermal sensor

**ALARM 30, Motor phase U missing**

Motor phase U between the adjustable frequency drive and the motor is missing.

Remove power from the adjustable frequency drive and check motor phase U.

**ALARM 31, Motor phase V missing**

Motor phase V between the adjustable frequency drive and the motor is missing.

Remove power from the adjustable frequency drive and check motor phase V.

**ALARM 32, Motor phase W missing**

Motor phase W between the adjustable frequency drive and the motor is missing.

Remove power from the adjustable frequency drive and check motor phase W.

**ALARM 33, Inrush fault**

Too many power-ups have occurred within a short time period. Let the unit cool to operating temperature.

**WARNING/ALARM 34, Fieldbus communication fault**

The serial communication bus on the communication option card is not working.

**WARNING/ALARM 36, Mains Failure**

This warning/alarm is only active if the supply voltage to the adjustable frequency drive is lost and *14-10 Mains Failure* is NOT set to [0] *No Function*. Check the fuses to the adjustable frequency drive and line power supply to the unit.

**ALARM 38, Internal fault**

When an internal fault occurs, a code number defined in the table below is displayed.

**Troubleshooting**

- Cycle power
- Check that the option is properly installed
- Check for loose or missing wiring

It may be necessary to contact the Danfoss supplier or service department. Note the code number for further troubleshooting directions.

No.	Text
0	Serial port cannot be initialized. Contact theDanfoss supplier or Danfoss Service Department.
256-258	Power EEPROM data is defective or too old.
512	Control board EEPROM data is defective or too old.
513	Communication timeout reading EEPROM data.
514	Communication timeout reading EEPROM data.
515	Application oriented control cannot recognize the EEPROM data.
516	Cannot write to the EEPROM because a write command is on progress.
517	Write command is under timeout.
518	Failure in the EEPROM.
519	Missing or invalid barcode data in EEPROM.
783	Parameter value outside of min/max limits.
1024-1279	A CAN message that has to be sent couldn't be sent.
1281	Digital signal processor flash timeout.
1282	Power micro software version mismatch.
1283	Power EEPROM data version mismatch.
1284	Cannot read digital signal processor software version.
1299	Option SW in slot A is too old.
1300	Option SW in slot B is too old.
1301	Option SW in slot C0 is too old.
1302	Option SW in slot C1 is too old.
1315	Option SW in slot A is not supported (not allowed).
1316	Option SW in slot B is not supported (not allowed).
1317	Option SW in slot C0 is not supported (not allowed).
1318	Option SW in slot C1 is not supported (not allowed).
1379	Option A did not respond when calculating platform version.
1380	Option B did not respond when calculating platform version.
1381	Option C0 did not respond when calculating platform version.
1382	Option C1 did not respond when calculating platform version.
1536	An exception in the application oriented control is registered. Debug information written in LCP.
1792	DSP watchdog is active. Debugging of power part data, motor oriented control data not transferred correctly.
2049	Power data restarted.
2064-2072	H081x: option in slot x has restarted.

No.	Text
2080-2088	H082x: option in slot x has issued a power-up wait.
2096-2104	H983x: option in slot x has issued a legal power-up wait.
2304	Could not read any data from power EEPROM.
2305	Missing SW version from power unit.
2314	Missing power unit data from power unit.
2315	Missing SW version from power unit.
2316	Missing lo_statepage from power unit.
2324	Power card configuration is determined to be incorrect at power-up.
2325	A power card has stopped communicating while line power is applied.
2326	Power card configuration is determined to be incorrect after the delay for power cards to register.
2327	Too many power card locations have been registered as present.
2330	Power size information between the power cards does not match.
2561	No communication from DSP to ATACD.
2562	No communication from ATACD to DSP (state running).
2816	Stack overflow control board module.
2817	Scheduler slow tasks.
2818	Fast tasks.
2819	Parameter thread.
2820	LCP stack overflow.
2821	Serial port overflow.
2822	USB port overflow.
2836	cfListMempool too small.
3072-5122	Parameter value is outside its limits.
5123	Option in slot A: Hardware incompatible with control board hardware.
5124	Option in slot B: Hardware incompatible with control board hardware.
5125	Option in slot C0: Hardware incompatible with control board hardware.
5126	Option in slot C1: Hardware incompatible with control board hardware.
5376-6231	Out of memory.

**Table 8.3**
**ALARM 39, Heatsink sensor**

No feedback from the heatsink temperature sensor.

The signal from the IGBT thermal sensor is not available on the power card. The problem could be on the power card, on the gate drive card, or the ribbon cable between the power card and gate drive card.

**WARNING 40, Overload of digital output terminal 27**

Check the load connected to terminal 27 or remove short-circuit connection. Check *5-00 Digital I/O Mode* and *5-01 Terminal 27 Mode*.

**WARNING 41, Overload of digital output terminal 29**

Check the load connected to terminal 29 or remove short-circuit connection. Check *5-00 Digital I/O Mode* and *5-02 Terminal 29 Mode*.

**WARNING 42, Overload of digital output on X30/6 or overload of digital output on X30/7**

For X30/6, check the load connected to X30/6 or remove the short-circuit connection. Check *5-32 Term X30/6 Digi Out (MCB 101)*.

For X30/7, check the load connected to X30/7 or remove the short-circuit connection. Check *5-33 Term X30/7 Digi Out (MCB 101)*.

**ALARM 46, Power card supply**

The supply on the power card is out of range.

There are three power supplies generated by the switch mode power supply (SMPS) on the power card: 24 V, 5 V, ±18 V. When powered with 24 V DC with the MCB 107 option, only the 24 V and 5 V supplies are monitored. When powered with three phase AC line voltage, all three supplies are monitored.

**WARNING 47, 24 V supply low**

The 24 V DC is measured on the control card. The external 24 V DC backup power supply may be overloaded, otherwise contact the Danfoss supplier.

**WARNING 48, 1.8 V supply low**

The 1.8 V DC supply used on the control card is outside of allowable limits. The power supply is measured on the control card. Check for a defective control card. If an option card is present, check for an overvoltage condition.

**WARNING 49, Speed limit**

When the speed is not within the specified range in *4-11 Motor Speed Low Limit [RPM]* and *4-13 Motor Speed High Limit [RPM]*, the adjustable frequency drive shows a warning. When the speed is below the specified limit in *1-86 Trip Speed Low [RPM]* (except when starting or stopping), the adjustable frequency drive will trip.

**ALARM 50, AMA calibration failed**

Contact the Danfoss supplier or Danfoss Service Department.

**ALARM 51, AMA check  $U_{nom}$  and  $I_{nom}$** 

The settings for motor voltage, motor current, and motor power are wrong. Check the settings in parameters 1-20 to 1-25.

**ALARM 52, AMA low  $I_{nom}$** 

The motor current is too low. Check the settings.

**ALARM 53, AMA motor too big**

The motor is too big for the AMA to operate.

**ALARM 54, AMA motor too small**

The motor is too small for the AMA to operate.

**ALARM 55, AMA parameter out of range**

The parameter values of the motor are outside of the acceptable range. AMA will not run.

**ALARM 56, AMA interrupted by user**

The user has interrupted the AMA.

**ALARM 57, AMA internal fault**

Try to restart AMA again a number of times until the AMA is carried out. Note that repeated runs may heat the motor to a level where the resistance  $R_s$  and  $R_r$  are increased. In most cases, however, this is not critical.

**ALARM 58, Internal fault**

Contact the Danfoss supplier.

**WARNING 59, Current limit**

The current is higher than the value in *4-18 Current Limit*. Ensure that motor data in parameters 1-20 to 1-25 are set correctly. Possibly increase the current limit. Be sure that the system can operate safely at a higher limit.

**WARNING 60, External interlock**

External interlock has been activated. To resume normal operation, apply 24 V DC to the terminal programmed for external interlock and reset the adjustable frequency drive (via serial communication, digital I/O, or by pressing [Reset]).

**WARNING/ALARM 61, Tracking error**

An error between calculated motor speed and speed measurement from feedback device. The function Warning/Alarm/Disable is set in *4-30 Motor Feedback Loss Function*. Accepted error setting in *4-31 Motor Feedback Speed Error* and the allowed time the error occur setting in *4-32 Motor Feedback Loss Timeout*. During a commissioning procedure the function may be effective.

**WARNING 62, Output frequency at maximum limit**

The output frequency is higher than the value set in *4-19 Max Output Frequency*.

**ALARM 64, Voltage Limit**

The load and speed combination demands a motor voltage higher than the actual DC link voltage.

**WARNING/ALARM 65, Control card over temperature**

The control card has reached its trip temperature of 167° F [75°C].

**WARNING 66, Heatsink temperature low**

The adjustable frequency drive is too cold to operate. This warning is based on the temperature sensor in the IGBT module.

Increase the ambient temperature of the unit. Also, a trickle amount of current can be supplied to the adjustable frequency drive whenever the motor is stopped by setting

*2-00 DC Hold/Preheat Current at 5% and 1-80 Function at Stop*

**Troubleshooting**

The heatsink temperature measured as 32° F [0°C] could indicate that the temperature sensor is defective, causing the fan speed to increase to the maximum. If the sensor wire between the IGBT and the gate drive card is disconnected, this warning would result. Also, check the IGBT thermal sensor.

**ALARM 67, Option module configuration has changed**

One or more options have either been added or removed since the last power-down. Check that the configuration change is intentional and reset the unit.

**ALARM 68, Safe Stop activated**

Safe stop has been activated. To resume normal operation, apply 24 V DC to terminal 37, then send a reset signal (via bus, digital I/O, or by pressing [Reset]).

**ALARM 69, Power card temperature**

The temperature sensor on the power card is either too hot or too cold.

**Troubleshooting**

- Check the operation of the door fans
- Check that the filters for the door fans are not blocked
- Check that the connector plate is properly installed on IP21/IP54 (NEMA 1/12) adjustable frequency drives

**ALARM 70, Illegal FC configuration**

The control card and power card are incompatible. Contact the supplier with the type code of the unit from the nameplate and the part numbers of the cards to check compatibility.

**ALARM 71, PTC 1 safe stop**

Safe Stop has been activated from the MCB 112 PTC Thermistor Card (motor too warm). Normal operation can be resumed when the MCB 112 applies 24 V DC to T37 again (when the motor temperature reaches an acceptable level) and when the digital input from the MCB 112 is deactivated. When that happens, a reset signal must be sent (via Bus, Digital I/O, or by pressing [Reset]).

**NOTE!**

**If automatic restart is enabled, the motor may start when the fault is cleared.**

**ALARM 72, Dangerous failure**

Safe Stop with Trip Lock. Unexpected signal levels on safe stop and digital input from the MCB 112 PTC thermistor card.

**WARNING 73, Safe stop auto restart**

Safe stopped. With automatic restart enabled, the motor may start when the fault is cleared.

**WARNING 76, Power unit set-up**

The required number of power units does not match the detected number of active power units.

**Troubleshooting:**

When replacing an F-frame module, this will occur if the power specific data in the module power card does not match the rest of the adjustable frequency drive. Confirm the spare part and its power card are the correct part number.

**WARNING 77, Reduced power mode**

This warning indicates that the adjustable frequency drive is operating in reduced power mode (i.e., less than the allowed number of inverter sections). This warning will be generated on power cycle when the adjustable frequency drive is set to run with fewer inverters and will remain on.

**ALARM 79, Illegal power section configuration**

The scaling card is the incorrect part number or not installed. Also MK102 connector on the power card could not be installed.

**ALARM 80, Drive initialized to default value**

Parameter settings are initialized to default settings after a manual reset. Reset the unit to clear the alarm.

**ALARM 81, CSIV corrupt**

CSIV file has syntax errors.

**ALARM 82, CSIV parameter error**

CSIV failed to init a parameter.

**ALARM 85, Dang fail PB**

Profibus/Profisafe Error.

**WARNING/ALARM 104, Mixing fan fault**

The fan monitor checks that the fan is spinning at drive power-up or whenever the mixing fan is turned on. If the fan is not operating, then the fault is annunciated. The mixing-fan fault can be configured as a warning or an alarm trip by *14-53 Fan Monitor*.

**Troubleshooting**

Cycle power to the adjustable frequency drive to determine if the warning/alarm returns.

**WARNING 250, New spare part**

A component in the adjustable frequency drive has been replaced. Reset the adjustable frequency drive for normal operation.

**WARNING 251, New type code**

The power card or other components have been replaced and the type code changed. Reset to remove the warning and resume normal operation.

## 9 Basic Troubleshooting

### 9.1 Start Up and Operation

Symptom	Possible cause	Test	Solution
Display dark/No function	Missing input power.	See <i>Table 3.1</i> .	Check the input power source.
	Missing or open fuses or circuit breaker tripped.	See open fuses and tripped circuit breaker in this table for possible causes.	Follow the recommendations provided.
	No power to the LCP.	Check the LCP cable for proper connection or damage.	Replace the faulty LCP or connection cable.
	Shortcut on control voltage (terminal 12 or 50) or at control terminals.	Check the 24 V control voltage supply for terminals 12/13 to 20-39 or 10 V supply for terminals 50 to 55.	Wire the terminals properly.
	Wrong LCP (LCP from VLT® 2800 or 5000/6000/8000/ FCD or FCM).		Use only LCP 101 (P/N 130B1124) or LCP 102 (P/N 130B1107).
	Wrong contrast setting.		Press [Status] + [▲]/[▼] to adjust the contrast.
	Display (LCP) is defective.	Test using a different LCP.	Replace the faulty LCP or connection cable.
	Internal voltage supply fault or SMPS is defective.		Contact supplier.
Intermittent display	Overloaded power supply (SMPS) due to improper control wiring or a fault within the adjustable frequency drive.	To rule out a problem in the control wiring, disconnect all control wiring by removing the terminal blocks.	If the display stays lit, then the problem is in the control wiring. Check the wiring for shorts or incorrect connections. If the display continues to cut out, follow the procedure for display dark.

Symptom	Possible cause	Test	Solution
Motor not running	Service switch open or missing motor connection.	Check if the motor is connected and the connection is not interrupted (by a service switch or other device).	Connect the motor and check the service switch.
	No line power with 24 V DC option card.	If the display is functioning but no output, check that line power is applied to the adjustable frequency drive.	Apply line power to run the unit.
	LCP Stop.	Check if [Off] has been pressed.	Press [Auto On] or [Hand On] (depending on operation mode) to run the motor.
	Missing start signal (Standby).	Check 5-10 <i>Terminal 18 Digital Input</i> for correct setting for terminal 18 (use default setting).	Apply a valid start signal to start the motor.
	Motor coast signal active (Coasting).	Check 5-12 <i>Coast inv.</i> for correct setting for terminal 27 (use default setting)..	Apply 24 V on terminal 27 or program this terminal to <i>No operation</i> .
	Wrong reference signal source.	Check reference signal: Local, remote or bus reference? Preset reference active? Terminal connection correct? Scaling of terminals correct? Reference signal available?	Program correct settings. Check 3-13 <i>Reference Site</i> . Set preset reference active in parameter group 3-1* <i>References</i> . Check for correct wiring. Check scaling of terminals. Check reference signal.
Motor running in wrong direction	Motor rotation limit.	Check that 4-10 <i>Motor Speed Direction</i> is programmed correctly.	Program correct settings.
	Active reversing signal.	Check if a reversing command is programmed for the terminal in parameter group 5-1* <i>Digital inputs</i> .	Deactivate reversing signal.
	Wrong motor phase connection.		See 2.4.5 <i>Motor Rotation Check</i> in this manual.
Motor is not reaching maximum speed	Frequency limits set wrong.	Check output limits in 4-13 <i>Motor Speed High Limit [RPM]</i> , 4-14 <i>Motor Speed High Limit [Hz]</i> and 4-19 <i>Max Output Frequency</i> .	Program correct limits.
	Reference input signal not scaled correctly.	Check reference input signal scaling in 6-0* <i>Analog I/O Mode</i> and parameter group 3-1* <i>References</i> . Reference limits in parameter group 3-0* <i>Reference Limit</i> .	Program correct settings.
Motor speed unstable	Possible incorrect parameter settings.	Check the settings of all motor parameters, including all motor compensation settings. For closed-loop operation, check PID settings.	Check settings in parameter group 1-6* <i>Analog I/O mode</i> . For closed-loop operation, check settings in parameter group 20-0* <i>Feedback</i> .
Motor runs rough	Possible over-magnetization.	Check for incorrect motor settings in all motor parameters.	Check motor settings in parameter groups 1-2* <i>Motor Data</i> , 1-3* <i>Adv Motor Data</i> , and 1-5* <i>Load Indep. Setting</i> .
Motor will not brake	Possible incorrect settings in the brake parameters. Possible too short ramp-down times.	Check brake parameters. Check ramp time settings.	Check parameter group 2-0* <i>DC Brake</i> and 3-0* <i>Reference Limits</i> .



Symptom	Possible cause	Test	Solution
Open power fuses or circuit breaker trip	Phase to phase short.	Motor or panel has a short phase to phase. Check motor and panel phase for shorts.	Eliminate any shorts detected.
	Motor overload.	Motor is overloaded for the application.	Perform startup test and verify motor current is within specifications. If motor current is exceeding nameplate full load current, motor may run only with reduced load. Review the specifications for the application.
	Loose connections.	Perform pre-startup check for loose connections.	Tighten loose connections.
Line power current imbalance greater than 3%	Problem with line power (See <i>Alarm 4 Mains phase loss</i> description).	Rotate input power leads into the adjustable frequency drive one position: A to B, B to C, C to A.	If imbalanced leg follows the wire, it is a power problem. Check line power supply.
	Problem with the adjustable frequency drive.	Rotate input power leads into the adjustable frequency drive one position: A to B, B to C, C to A.	If imbalance leg stays on same input terminal, it is a problem with the unit. Contact the supplier.
Motor current imbalance greater than 3%	Problem with motor or motor wiring.	Rotate output motor leads one position: U to V, V to W, W to U.	If imbalanced leg follows the wire, the problem is in the motor or motor wiring. Check motor and motor wiring.
	Problem with the adjustable frequency drives.	Rotate output motor leads one position: U to V, V to W, W to U.	If imbalance leg stays on same output terminal, it is a problem with the unit. Contact the supplier.
Acoustic noise or vibration (e.g., a fan blade is making noise or vibrations at certain frequencies)	Resonances, e.g., in the motor/fan system.	Bypass critical frequencies by using parameters in parameter group 4-6* <i>Speed Bypass</i> .	Check if noise and/or vibration have been reduced to an acceptable limit.
		Turn off overmodulation in 14-03 <i>Overmodulation</i> .	
		Change switching pattern and frequency in parameter group 14-0* <i>Inverter Switching</i> .	
		Increase Resonance Dampening in 1-64 <i>Resonance Dampening</i> .	

Table 9.1



## 10 Specifications

### 10.1 Power-dependent Specifications

	N110	N132	N160	N200	N250	N315			
<b>Normal Load*</b>	<b>NO</b>	<b>NO</b>	<b>NO</b>	<b>NO</b>	<b>NO</b>	<b>NO</b>			
Typical Shaft output at 400 V [kW]	110	132	160	200	250	315			
Typical Shaft output at 460 V [hp]	150	200	250	300	350	450			
Typical Shaft output at 480 V [kW]	132	160	200	250	315	355			
Enclosure IP21	D1h	D1h	D1h	D2h	D2h	D2h			
Enclosure IP54	D1h	D1h	D1h	D2h	D2h	D2h			
Enclosure IP20	D3h	D3h	D3h	D4h	D4h	D4h			
<b>Output current</b>									
Continuous (at 400 V) [A]	212	260	315	395	480	588			
Intermittent (60 s overload) (at 400 V) [A]	233	286	347	435	528	647			
Continuous (at 460/500 V) [A]	190	240	302	361	443	535			
Intermittent (60 s overload) (at 460/500 V) [kVA]	209	264	332	397	487	588			
Continuous kVA (at 400 V) [kVA]	147	180	218	274	333	407			
Continuous kVA (at 460 V) [kVA]	151	191	241	288	353	426			
<b>Max. Input current</b>									
Continuous (at 400 V) [A]	204	251	304		381	381	463	463	567
Continuous (at 460/500 V) [A]	183	231	291		348	348	427	427	516
Max. cable size: line power, motor, brake and load share mm (AWG)]	2x95 (2x3/0)			2x185 (2x350)					
Max. external electrical fuses [A]	315	350	400	550	630	800			
Estimated power loss at 400 V [hp, W]	3.426, 2555	3.955, 2949	5.048, 3764	5.510, 4109	6.878, 5129	8.935, 6663			
Estimated power loss at 460 V [hp, W]	3.027, 2257	3.646, 2719	4.857, 3622	4.775, 3561	6.112, 4558	7.648, 5703			
Weight, enclosure IP21, IP54 kg (lbs)	62 (135)			125 (275)					
Weight, enclosure IP20 kg (lbs)	62 (135)			125 (275)					
Efficiency	0.98								
Output frequency	0–590 Hz								
*Normal overload=110% current for 60 s									

Table 10.1 Line Power Supply 3x380–480 V AC

	<b>N75K</b>	<b>N90K</b>	<b>N110</b>	<b>N132</b>	<b>N160</b>	<b>N200</b>
<b>Normal Load*</b>	<b>NO</b>	<b>NO</b>	<b>NO</b>	<b>NO</b>	<b>NO</b>	<b>NO</b>
Typical Shaft output at 550 V [kW]	55	75	90	110	132	160
Typical Shaft output at 575 V [hp]	75	100	125	150	200	250
Typical Shaft output at 690 V [kW]	75	90	110	132	160	200
Enclosure IP21	D1h	D1h	D1h	D1h	D1h	D2h
Enclosure IP54	D1h	D1h	D1h	D1h	D1h	D2h
Enclosure IP20	D3h	D3h	D3h	D3h	D3h	D4h
<b>Output current</b>						
Continuous (at 550 V) [A]	90	113	137	162	201	253
Intermittent (60 s overload) (at 550 V) [A]	99	124	151	178	221	278
Continuous (at 575/690 V) [A]	86	108	131	155	192	242
Intermittent (60 s overload) (at 575/690 V) [kVA]	95	119	144	171	211	266
Continuous kVA (at 550 V) [kVA]	86	108	131	154	191	241
Continuous kVA (at 575 V) [kVA]	86	108	130	154	191	241
Continuous kVA (at 690 V) [kVA]	103	129	157	185	229	289
<b>Max. Input current</b>						
Continuous (at 550 V) [A]	89	110	130	158	198	245
Continuous (at 575 V) [A]	85	106	124	151	189	234
Continuous (at 690 V) [A]	87	109	128	155	197	240
Max. cable size: line power, motor, brake and load share [mm (AWG)]	2x95 (2x3/0)					2x185 (2x350 mcm)
Max. external electrical fuses [A]	160	315	315	315	350	350
Estimated power loss at 575 V [hp, W]	1.557, 1161	1.912, 1426	2.332, 1739	2.815, 2099	3.548, 2646	4.118, 3071
Estimated power loss at 690 V [hp, W]	1.613, 1203	1.979, 1476	2.408, 1796	2.903, 2165	3.672, 2738	4.254, 3172
Weight, enclosure IP21, IP54 kg (lbs)	62 (135)					125 (275)
Weight, enclosure IP20 kg (lbs)	62 (135)					125 (275)
Efficiency	0.98					
Output frequency	0–590 Hz					
Heatsink overtemp. trip	230° F [110°C]					
Power card ambient trip	167° F [75°C]					
*Normal overload=110% current for 60 s						

**Table 10.2 Line Power Supply 3x525–690 V AC**

**Specifications** **VLT® AQUA Drive D-Frame**  
**Instruction Manual**

	<b>N250</b>	<b>N315</b>	<b>N400</b>
<b>Normal Load*</b>	<b>NO</b>	<b>NO</b>	<b>NO</b>
Typical Shaft output at 550 V [kW]	200	250	315
Typical Shaft output at 575 V [hp]	300	350	400
Typical Shaft output at 690 V [kW]	250	315	400
Enclosure IP21	D2h	D2h	D2h
Enclosure IP54	D2h	D2h	D2h
Enclosure IP20	D4h	D4h	D4h
<b>Output current</b>			
Continuous (at 550 V) [A]	303	360	418
Intermittent (60 s overload) (at 550 V) [A]	333	396	460
Continuous (at 575/690 V) [A]	290	344	400
Intermittent (60 s overload) (at 575/690 V) [kVA]	319	378	440
Continuous kVA (at 550 V) [kVA]	289	343	398
Continuous kVA (at 575 V) [kVA]	289	343	398
Continuous kVA (at 690 V) [kVA]	347	411	478
<b>Max. Input current</b>			
Continuous (at 550 V) [A]	299	355	408
Continuous (at 575 V) [A]	286	339	390
Continuous (at 690 V) [A]	296	352	400
Max. cable size: line power, motor, brake and load share, mm (AWG)	2x185 (2x350 mcm)		
Max. external electrical fuses [A]	400	500	550
Estimated power loss at 575 V [hp, W]	4.987, 3719	5.981, 4460	6.736, 5023
Estimated power loss at 690 V [hp, W]	5.160, 3848	6.182, 4610	6.906, 5150
Weight, enclosure IP21, IP54 kg (lbs)	125 (275)		
Weight, enclosure IP20 kg (lbs)	125 (275)		
Efficiency	0.98		
Output frequency	0–590 Hz		
Heatsink overtemp. trip	230° F [110°C]		
Power card ambient trip	167° F [75°C]		

\*Normal overload=110% current for 60 s

**Table 10.3 Line Power Supply 3x525–690 V AC**

The typical power loss is at nominal load conditions and expected to be within  $\pm 15\%$  (tolerance relates to variety in voltage and cable conditions).

The losses are based on the default switching frequency. The losses increase significantly at higher switching frequencies.

The options cabinet adds weight to the adjustable frequency drive. The maximum weights of the D5h–D8h frames is shown in *Table 10.4*

<b>Frame size</b>	<b>Description</b>	<b>Maximum weight, kg (lbs)</b>
D5h	D1h ratings+disconnect and/or brake chopper	116 (255)
D6h	D1h ratings+contactor and/or circuit breaker	129 (285)
D7h	D2h ratings+disconnect and/or brake chopper	200 (440)
D8h	D2h ratings+contactor and/or circuit breaker	225 (496)

**Table 10.4 D5h–D8h Weights**

## 10.2 General Technical Data

### Line power supply (L1, L2, L3)

Supply voltage ..... 380–480 V ±10%, 525–690 V ±10%

*AC line voltage low/line voltage drop-out:*

*During low AC line voltage or a line drop-out, the adjustable frequency drive continues until the intermediate circuit voltage drops below the minimum stop level, which corresponds typically to 15% below the adjustable frequency drive's lowest rated supply voltage. Power-up and full torque cannot be expected at AC line voltage lower than 10% below the adjustable frequency drive's lowest rated supply voltage.*

Supply frequency ..... 50/60 Hz ±5%

Max. temporary imbalance between line phases ..... 3.0% of rated supply voltage

True Power Factor ( $\lambda$ ) ..... ≥0.9 nominal at rated load

Displacement Power Factor ( $\cos \Phi$ ) near unity ..... (>0.98)

Switching on input supply L1, L2, L3 (power-ups) ..... maximum one time/2 min

Environment according to EN60664-1 ..... overvoltage category III/pollution degree 2

*The unit is suitable for use on a circuit capable of delivering not more than 100,000 RMS symmetrical Amperes, 480/600 V*

### Motor Output (U, V, W)

Output voltage ..... 0–100% of supply voltage

Output frequency ..... 0–590 Hz\*

Switching on output ..... Unlimited

Ramp times ..... 0.01–3,600 s

\* *Dependent on voltage and power*

### Torque Characteristics

Starting torque (Constant torque) ..... maximum 110% for 60 s\*

Starting torque ..... maximum 135% up to 0.5 s\*

Overload torque (Constant torque) ..... maximum 110% for 60 s\*

\*<sup>1)</sup> *Percentage relates to the adjustable frequency drive's nominal torque*

### Cable lengths and cross-sections

Max. motor cable length, shielded/armored ..... 500 ft [150 m]

Max. motor cable length, unshielded/unarmored ..... 1,000 ft [300 m]

Max. cross-section to motor, line power, load sharing and brake \*

Maximum cross-section to control terminals, rigid wire ..... 0.0023 in<sup>2</sup> [1.5 mm<sup>2</sup>]/16 AWG (2x0.75 mm<sup>2</sup>)

Maximum cross-section to control terminals, flexible cable ..... 0.0016 in<sup>2</sup> [1 mm<sup>2</sup>]/18 AWG

Maximum cross-section to control terminals, cable with enclosed core ..... 0.0008 in<sup>2</sup> [0.5 mm<sup>2</sup>]/20 AWG

Minimum cross-section to control terminals ..... 0.00039 in<sup>2</sup> [0.25 mm<sup>2</sup>]

\*<sup>1)</sup> *Depending on voltage and power.*

### Digital inputs

Programmable digital inputs ..... 4 (6)

Terminal number ..... 18, 19, 27<sup>1)</sup>, 29<sup>1)</sup>, 32, 33

Logic ..... PNP or NPN

Voltage level ..... 0–24 V DC

Voltage level, logic '0' PNP ..... <5 V DC

Voltage level, logic '1' PNP ..... >10 V DC

Voltage level, logic '0' NPN ..... >19 V DC

Voltage level, logic '1' NPN ..... <14 V DC

Maximum voltage on input ..... 28 V DC

Input resistance, R<sub>i</sub> ..... approx. 4 kΩ

*All digital inputs are galvanically isolated from the supply voltage (PELV) and other high-voltage terminals.*

<sup>1)</sup> *Terminals 27 and 29 can also be programmed as output.*

**Specifications** **VLT® AQUA Drive D-Frame**  
**Instruction Manual**

<b>Analog inputs</b>	
Number of analog inputs	2
Terminal number	53, 54
Modes	Voltage or current
Mode select	Switches A53 and A54
Voltage mode	Switch A53/A54=(U)
Voltage level	0 V to 10 V (scaleable)
Input resistance, $R_i$	approx. 10 k $\Omega$
Max. voltage	$\pm 20$ V
Current mode	Switch A53/A54=(I)
Current level	0/4 to 20 mA (scaleable)
Input resistance, $R_i$	approx. 200 $\Omega$
Max. current	30 mA
Resolution for analog inputs	10 bit (+sign)
Accuracy of analog inputs	Max. error 0.5% of full scale
Bandwidth	100 Hz

The analog inputs are galvanically isolated from the supply voltage (PELV) and other high-voltage terminals.

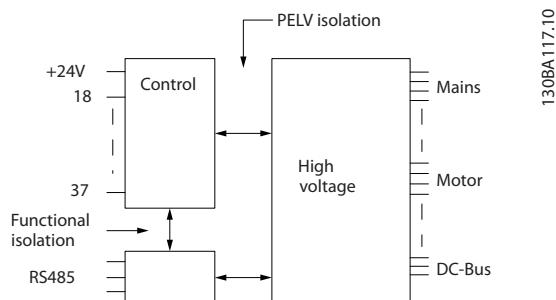

Figure 10.1

<b>Pulse inputs</b>	
Programmable pulse inputs	2
Terminal number pulse	29, 33
Max. frequency at terminal, 29, 33	110 kHz (push-pull driven)
Max. frequency at terminal, 29, 33	5 kHz (open collector)
Min. frequency at terminal 29, 33	4 Hz
Voltage level	see 10.2.1 Digital Inputs:
Maximum voltage on input	28 V DC
Input resistance, $R_i$	approx. 4 k $\Omega$
Pulse input accuracy (0.1–1 kHz)	Max. error: 0.1% of full scale
<b>Analog output</b>	
Number of programmable analog outputs	1
Terminal number	42
Current range at analog output	0/4–20 mA
Max. resistor load to common at analog output	500 $\Omega$
Accuracy on analog output	Max. error: 0.8% of full scale
Resolution on analog output	8 bit

The analog output is galvanically isolated from the supply voltage (PELV) and other high-voltage terminals.

<b>Control card, RS-485 serial communication</b>	
Terminal number	68 (P,TX+, RX+), 69 (N,TX-, RX-)
Terminal number 61	Common for terminals 68 and 69

The RS-485 serial communication circuit is functionally seated from other central circuits and galvanically isolated from the supply voltage (PELV).

**Specifications** **VLT® AQUA Drive D-Frame**  
**Instruction Manual**

<b>Digital output</b>	
Programmable digital/pulse outputs	2
Terminal number	27, 29 <sup>1)</sup>
Voltage level at digital/frequency output	0–24 V
Max. output current (sink or source)	40 mA
Max. load at frequency output	1 kΩ
Max. capacitive load at frequency output	10 nF
Minimum output frequency at frequency output	0 Hz
Maximum output frequency at frequency output	32 kHz
Accuracy of frequency output	Max. error: 0.1% of full scale
Resolution of frequency outputs	12 bit

<sup>1)</sup> Terminal 27 and 29 can also be programmed as input.

The digital output is galvanically isolated from the supply voltage (PELV) and other high-voltage terminals.

<b>Control card, 24 V DC output</b>	
Terminal number	12, 13
Max. load	200 mA

The 24 V DC supply is galvanically isolated from the supply voltage (PELV), but has the same potential as the analog and digital inputs and outputs.

<b>Relay outputs</b>	
Programmable relay outputs	2
<b>Relay 01 Terminal number</b>	1-3 (break), 1-2 (make)
Max. terminal load (AC-1) <sup>1)</sup> on 1-2 (NO) (resistive load) <sup>2)3)</sup>	400 V AC, 2 A
Max. terminal load (AC-15) <sup>1)</sup> on 1-2 (NO) (inductive load @ cosφ 0.4)	240 V AC, 0.2 A
Max. terminal load (DC-1) <sup>1)</sup> on 1-2 (NO) (resistive load)	80 V DC, 2 A
Max. terminal load (DC-13) <sup>1)</sup> on 1-2 (NO) (inductive load)	24 V DC, 0.1 A
Max. terminal load (AC-1) <sup>1)</sup> on 1-3 (NC) (resistive load)	240 V AC, 2 A
Max. terminal load (AC-15) <sup>1)</sup> on 1-3 (NC) (inductive load @ cosφ 0.4)	240 V AC, 0.2 A
Max. terminal load (DC-1) <sup>1)</sup> on 1-3 (NC) (resistive load)	50 V DC, 2 A
Max. terminal load (DC-13) <sup>1)</sup> on 1-3 (NC) (inductive load)	24 V DC, 0.1 A
Min. terminal load on 1-3 (NC), 1-2 (NO)	24 V DC 10 mA, 24V AC 2 mA
Environment according to EN 60664-1	overvoltage category III/pollution degree 2
<b>Relay 02 Terminal number</b>	4-6 (break), 4-5 (make)
Max. terminal load (AC-1) <sup>1)</sup> on 4-5 (NO) (resistive load) <sup>2)3)</sup>	400 V AC, 2 A
Max. terminal load (AC-15) <sup>1)</sup> on 4-5 (NO) (inductive load @ cosφ 0.4)	240 V AC, 0.2 A
Max. terminal load (DC-1) <sup>1)</sup> on 4-5 (NO) (resistive load)	80 V DC, 2 A
Max. terminal load (DC-13) <sup>1)</sup> on 4-5 (NO) (inductive load)	24 V DC, 0.1 A
Max. terminal load (AC-1) <sup>1)</sup> on 4-6 (NC) (resistive load)	240 V AC, 2 A
Max. terminal load (AC-15) <sup>1)</sup> on 4-6 (NC) (inductive load @ cosφ 0.4)	240 V AC, 0.2 A
Max. terminal load (DC-1) <sup>1)</sup> on 4-6 (NC) (resistive load)	50 V DC, 2 A
Max. terminal load (DC-13) <sup>1)</sup> on 4-6 (NC) (inductive load)	24 V DC, 0.1 A
Min. terminal load on 4-6 (NC), 4-5 (NO)	24 V DC 10 mA, 24 V AC 2 mA
Environment according to EN 60664-1	overvoltage category III/pollution degree 2

<sup>1)</sup> IEC 60947 t 4 and 5

The relay contacts are galvanically isolated from the rest of the circuit by reinforced isolation (PELV).

<sup>2)</sup> Overvoltage Category II

<sup>3)</sup> UL applications 300 V AC 2 A



---

**Specifications** **VLT® AQUA Drive D-Frame**  
**Instruction Manual**

---

Control card, 10 V DC output	
Terminal number	50
Output voltage	10.5 V ±0.5 V
Max. load	25 mA

*The 10 V DC supply is galvanically isolated from the supply voltage (PELV) and other high-voltage terminals.*

Control characteristics	
Resolution of output frequency at 0–1000 Hz	± 0.003 Hz
System response time (terminals 18, 19, 27, 29, 32, 33)	≤2 ms
Speed control range (open-loop)	1:100 of synchronous speed
Speed accuracy (open-loop)	30–4,000 rpm: Maximum error of ±8 rpm

*All control characteristics are based on a 4-pole asynchronous motor.*

Surroundings	
Enclosure type D1h/D2h/D5h/D6h/D7h/D8h	IP21/Type 1, IP54/Type12
Enclosure type D3h/D4h	IP20/Chassis
Vibration test all enclosure types	1.0 g
Relative humidity	5%–95% (IEC 721-3-3; Class 3K3 (non-condensing) during operation
Aggressive environment (IEC 60068-2-43) H <sub>2</sub> S test	class Kd
Test method according to IEC 60068-2-43 H <sub>2</sub> S (10 days)	
Ambient temperature (at 60 AVM switching mode)	
- with derating	max. 131° F [55°C] <sup>1)</sup>
- with full output power of typical EFF2 motors (up to 90% output current)	max. 122° F [50°C] <sup>1)</sup>
- at full continuous FC output current	max. 113° F [45°C] <sup>1)</sup>

<sup>1)</sup> For more information on derating see the Design Guide, section on Special Conditions.

Minimum ambient temperature during full-scale operation	32° F [0°C]
Minimum ambient temperature at reduced performance	14° F [-10°C]
Temperature during storage/transport	-13°–149°/158° F [-25 to +65°/70°C]
Maximum altitude above sea level without derating	3,300 ft [1,000 m]
Maximum altitude above sea level with derating	10,000 ft [3,000 m]

<sup>1)</sup> For more information on derating see the Design Guide, section on Special Conditions.

EMC standards, Emission	EN 61800-3, EN 61000-6-3/4, EN 55011, IEC 61800-3 EN 61800-3, EN 61000-6-1/2,
EMC standards, Immunity	EN 61000-4-2, EN 61000-4-3, EN 61000-4-4, EN 61000-4-5, EN 61000-4-6

*See the Design Guide, section on Special Conditions.*

Control card performance	
Scan interval	5 ms

Control card, USB Serial Communication	
USB standard	1.1 (Full speed)
USB plug	USB type B "device" plug

**⚠ CAUTION**

Connection to PC is carried out via a standard host/device USB cable.  
 The USB connection is galvanically isolated from the supply voltage (PELV) and other high-voltage terminals.  
 The USB connection is not galvanically isolated from protection ground. Use only an isolated laptop/PC as the connection to the USB connector on the adjustable frequency drive or an isolated USB cable/drive.

Protection and Features

- Electronic thermal motor protection against overload.
- Temperature monitoring of the heatsink ensures that the adjustable frequency drive trips if the temperature reaches 203° F ±10° F [95° C ±5° C]. An overload temperature cannot be reset until the temperature of the heatsink is below 158° F ±9° F [70° C ±5° C] (Guideline - these temperatures may vary for different power sizes, enclosures, etc.). The adjustable frequency drive has an auto derating function to avoid its heatsink reaching 203° F [95° C].
- The adjustable frequency drive is protected against short-circuits on motor terminals U, V, W.
- If a line phase is missing, the adjustable frequency drive trips or issues a warning (depending on the load).
- Monitoring of the intermediate circuit voltage ensures that the adjustable frequency drive trips if the intermediate circuit voltage is too low or too high.
- The adjustable frequency drive is protected against ground faults on motor terminals U, V, W.

### 10.3 Fuse Tables

#### 10.3.1 Protection

**Branch Circuit Protection**

In order to protect the installation against electrical and fire hazard, all branch circuits in an installation, switch gear, machines, etc., must be short-circuited and overcurrent protected according to national/international regulations.

**Short-circuit Protection** The adjustable frequency drive must be protected against short-circuit to avoid electrical or fire hazard. Danfoss recommends using the fuses mentioned below to protect service personnel and equipment in case of an internal failure in the adjustable frequency drive. The adjustable frequency drive provides full short-circuit protection in case of a short-circuit on the motor output.

**Overcurrent Protection:**

Provide overload protection to avoid fire hazard due to overheating of the cables in the installation. The adjustable

frequency drive is equipped with internal overcurrent protection that can be used for upstream overload protection (UL applications excluded). See 4-18 *Current Limit*. Moreover, fuses or circuit breakers can be used to provide the overcurrent protection in the installation. Overcurrent protection must always be carried out according to national regulations.

#### 10.3.2 Fuse Selection

Danfoss recommends using the following fuses which will ensure compliance with EN50178. In case of malfunction, not following the recommendation may result in unnecessary damage to the adjustable frequency drive.

The fuses below are suitable for use on a circuit capable of delivering 100,000 Arms (symmetrical).

N110-N315	380–500 V	type aR
N75K–N400	525–690 V	type aR

**Table 10.5**

**Specifications** **VLT® AQUA Drive D-Frame**  
**Instruction Manual**

Power Size	Fuse options							
	Bussman PN	Littelfuse PN	Littelfuse PN	Bussmann PN	Siba PN	Ferraz-Shawmut PN	Ferraz-Shawmut PN (Europe)	Ferraz-Shawmut PN (North America)
N110	170M2619	LA50QS300-4	L50S-300	FWH-300A	20 610 31.315	A50QS300-4	6.9URD31D08A0315	A070URD31KI0315
N132	170M2620	LA50QS350-4	L50S-350	FWH-350A	20 610 31.350	A50QS350-4	6.9URD31D08A0350	A070URD31KI0350
N160	170M2621	LA50QS400-4	L50S-400	FWH-400A	20 610 31.400	A50QS400-4	6.9URD31D08A0400	A070URD31KI0400
N200	170M4015	LA50QS500-4	L50S-500	FWH-500A	20 610 31.550	A50QS500-4	6.9URD31D08A0550	A070URD31KI0550
N250	170M4016	LA50QS600-4	L50S-600	FWH-600A	20 610 31.630	A50QS600-4	6.9URD31D08A0630	A070URD31KI0630
N315	170M4017	LA50QS800-4	L50S-800	FWH-800A	20 610 31.800	A50QS800-4	6.9URD32D08A0800	A070URD31KI0800

**Table 10.6 Fuse Options for 380-480 V Adjustable Frequency Drives**

OEM		Fuse options		
VLT Model	Bussmann PN	Siba PN	Ferraz-Shawmut European PN	Ferraz-Shawmut North American PN
N75k T7	170M2616	20 610 31.160	6.9URD30D08A0160	A070URD30KI0160
N90k T7	170M2619	20 610 31.315	6.9URD31D08A0315	A070URD31KI0315
N110 T7	170M2619	20 610 31.315	6.9URD31D08A0315	A070URD31KI0315
N132 T7	170M2619	20 610 31.315	6.9URD31D08A0315	A070URD31KI0315
N160 T7	170M2619	20 610 31.315	6.9URD31D08A0315	A070URD31KI0315
N200 T7	170M4015	20 620 31.550	6.9URD32D08A0550	A070URD32KI0550
N250 T7	170M4015	20 620 31.550	6.9URD32D08A0550	A070URD32KI0550
N315 T7	170M4015	20 620 31.550	6.9URD32D08A0550	A070URD32KI0550
N400 T7	170M4015	20 620 31.550	6.9URD32D08A0550	A070URD32KI0550

**Table 10.7 Fuse Options for 525–690 V Adjustable Frequency Drives**

For UL compliance, for units supplied without a contactor-only option, the Bussmann 170M series fuses must be used. See *Table 10.9* for SCCR ratings and UL fuse criteria if a contactor-only option is supplied with the adjustable frequency drive.

### 10.3.3 Short Circuit Current Rating (SCCR)

If the adjustable frequency drive is not supplied with a line power disconnect, contactor or circuit breaker, the Short Circuit Current Rating (SCCR) of the adjustable frequency drives is 100,000 amps at all voltages (380–690 V).

If the adjustable frequency drive is supplied with a line power disconnect, the SCCR of the adjustable frequency drive is 100,000 amps at all voltages (380–690 V).

If the adjustable frequency drive is supplied with a circuit breaker, the SCCR depends on the voltage, see *Table 10.8*:

	415 V	480 V	600 V	690 V
D6h frame	100,000 A	100,000 A	65,000 A	70,000 A
D8h frame	100,000 A	100,000 A	42,000 A	30,000 A

**Table 10.8**

If the adjustable frequency drive is supplied with a contactor-only option and is externally fused according to *Table 10.9*, the SCCR of the adjustable frequency drive is as follows:

	415 V IEC <sup>1)</sup>	480 V UL <sup>2)</sup>	600 V UL <sup>2)</sup>	690 V IEC <sup>1)</sup>
D6h frame	100,000 A	100,000 A	100,000 A	100,000 A
D8h frame (not including the N315T4)	100,000 A	100,000 A	100,000 A	100,000 A
D8h frame (N315T4 only)	100,000 A	Consult factory	Not applicable	

**Table 10.9**

<sup>1)</sup> With a Bussmann type LPJ-SP or Gould Shawmut type AJT fuse. 450 A max fuse size for D6h and 900 A max fuse size for D8h.

<sup>2)</sup> Must use Class J or L branch fuses for UL approval. 450 A max fuse size for D6h and 600 A max fuse size for D8h.

### 10.3.4 Connection Tightening Torques

When tightening all electrical connections, it is very important to tighten with the correct torque. Too low or too high torque results in a bad electrical connection. Use a torque wrench to ensure correct torque. Always use a torque wrench to tighten the bolts.

Frame Size	Terminal	Torque	Bolt size
D1h/D3h/D5h/ D6h	Line power Motor Load sharing Regen	19–40 Nm (168–354 in- lbs)	M10
	Ground Brake	8.5–20.5 Nm (75–181 in-lbs)	M8
D2h/D4h/D7h/ D8h	Line power Motor Regen Load sharing Ground	19–40 Nm (168–354 in- lbs)	M10
	Brake	8.5–20.5 Nm (75–181 in-lbs)	M8

**Table 10.10 Torque for Terminals**

## Index

### A

#### AC

Input.....	1-4, 2-21
Line Input Connection.....	2-21
Line Power.....	1-3, 1-4
Line Voltage.....	4-2, 4-3, 7-1
Waveform.....	1-3, 1-4

<b>Accel Time.....</b>	3-4
------------------------	-----

<b>Adjustable Frequency Drive Block Diagram.....</b>	1-4
--	-----

<b>Airflow.....</b>	2-2
---------------------	-----

<b>Alarm Log.....</b>	4-2
-----------------------	-----

#### AMA

AMA.....	8-5, 8-8
With T27 Connected.....	6-1
Without T27 Connected.....	6-1

#### Analog

Inputs.....	2-23, 8-4, 10-5
Output.....	2-23, 10-5
Signal.....	8-4

<b>Application Examples.....</b>	6-1
----------------------------------	-----

#### Auto

Auto.....	4-3, 7-1
Mode.....	4-2
On.....	7-1, 4-3, 7-1

<b>Automatic Motor Adaptation.....</b>	7-1
--	-----

<b>Auto-reset.....</b>	4-1
------------------------	-----

### B

<b>Basic Operational Programming.....</b>	3-2
---	-----

<b>Braking.....</b>	8-6, 7-1
---------------------	----------

### C

<b>Cable Lengths And Cross-sections.....</b>	10-4
--	------

<b>Circuit Breakers.....</b>	3-1, 8-3
------------------------------	----------

<b>Closed-loop.....</b>	2-24
-------------------------	------

<b>Communication Option.....</b>	8-7
----------------------------------	-----

<b>Conduit.....</b>	2-5, 3-1, 8-3
---------------------	---------------

### Control

Cables.....	2-23
Card.....	8-4
Card Performance.....	10-7
Card, 10 V DC Output.....	10-7
Card, 24 V DC Output.....	10-6
Card, RS-485 Serial Communication.....	10-5
Card, USB Serial Communication.....	10-7
Characteristics.....	10-7
Signal.....	5-1
System.....	1-3
Terminal Functions.....	2-24
Terminal Types.....	2-23
Terminals.....	3-2, 4-3, 7-1, 5-3, 2-24
Wiring.....	2-3, 2-5, 2-6, 3-1, 8-3
Wiring Connection.....	2-22

### Cooling

Cooling.....	2-1
Clearance.....	3-1, 8-3

<b>Copying Parameter Settings.....</b>	4-3
--	-----

### Current

Limit.....	3-4
Rating.....	2-1, 8-4

### D

#### DC

Current.....	1-4, 7-1
Link.....	8-4

<b>Derating.....</b>	10-7, 10-8, 2-1
----------------------	-----------------

#### Digital

Input.....	2-23, 7-1, 8-5
Inputs.....	7-1, 5-3, 10-4
Output.....	10-6

<b>Disconnect Switch.....</b>	3-2
-------------------------------	-----

<b>Display Menu Keys.....</b>	4-2
-------------------------------	-----

<b>Downloading Data From The LCP.....</b>	4-4
---	-----

<b>Duct Cooling.....</b>	2-1
--------------------------	-----

### E

#### Electrical

Installation.....	2-3
Noise.....	2-6

<b>EMC.....</b>	2-23, 3-1, 8-3, 10-7
-----------------	----------------------

<b>Equalizing Cable.....</b>	2-23
------------------------------	------

#### External

Commands.....	1-4, 7-1
Controllers.....	1-3
Interlock.....	5-4
Voltage.....	5-1

### F

#### Fault

Log.....	4-2
Messages.....	8-4

<b>Feedback</b> .....	2-24, 3-1, 8-3, 8-8, 7-1	<b>Line</b>	
<b>Floating Delta</b> .....	2-21	Power.....	2-5
<b>Frame Sizes And Power Ratings</b> .....	1-5	Power Supply (L1, L2, L3).....	10-4
<b>Full Load Current</b> .....	2-1	<b>Local</b>	
<b>Functional Testing</b> .....	1-3, 3-4	Control.....	4-1, 4-3, 7-1
<b>Fuses</b> .....	3-1, 8-3, 8-7, 9-1	Control Panel.....	4-1
<b>Fusing</b> .....	2-5, 3-1, 8-3	Control Test.....	3-4
		Mode.....	3-4
		Operation.....	4-1
		Start.....	3-4
<b>G</b>			
<b>Ground</b>		<b>M</b>	
Connections.....	2-6, 3-1, 8-3	<b>Main Menu</b> .....	5-1, 4-2
Loops.....	2-23	<b>Manual Initialization</b> .....	4-4
Wire.....	2-6, 3-1, 8-3	<b>Mechanical Installation</b> .....	2-1
<b>Grounded Delta</b> .....	2-21	<b>Menu</b>	
<b>Grounding</b>		Keys.....	4-1, 4-2
Grounding.....	2-6, 3-1, 8-3	Structure.....	4-3, 5-4
IP20 Enclosures.....	2-7	<b>Motor</b>	
IP21/54 Enclosures.....	2-7	Cable.....	2-21
Of Shielded Control Cables.....	2-23	Cables.....	2-5, 2-7
		Connection.....	2-7
		Current.....	1-4, 8-8, 4-2
		Data.....	3-2, 3-4, 8-5, 8-9
		Frequency.....	4-2
		Output (U, V, W).....	10-4
		Power.....	2-5, 8-8, 4-2
		Protection.....	2-5, 10-8
		Rotation.....	4-2
		Rotation Check.....	2-21
		Speeds.....	3-2
		Status.....	1-3
		Wiring.....	2-3, 2-5, 3-1, 8-3
		<b>Mounting</b> .....	3-1, 8-3
<b>'Grounding Hazard</b> .....	2-6	<b>Multiple Adjustable Frequency Drives</b> .....	2-5, 2-7
<b>H</b>		<b>N</b>	
<b>Hand</b>		<b>Navigation Keys</b> .....	3-2, 5-1, 4-3
Hand.....	3-4, 4-3, 7-1	<b>Noise Isolation</b> .....	2-3, 3-1, 8-3
On.....	7-1, 3-4, 4-3		
<b>Harmonics</b> .....	1-4	<b>O</b>	
		<b>Open-loop</b> .....	2-24, 5-1, 10-7
		<b>Operation Keys</b> .....	4-3
		<b>Optional Equipment</b> .....	3-2, 1-3
		<b>Output</b>	
		Current.....	7-1, 8-4, 10-6
		Signal.....	5-4
		<b>Overcurrent</b> .....	7-1
		<b>Overload Protection</b> .....	2-1, 2-5
		<b>Overvoltage</b> .....	3-4, 7-1
<b>I</b>			
<b>IEC 61800-3</b> .....	10-7		
<b>Induced Voltage</b> .....	2-5		
<b>Initialization</b> .....	4-4		
<b>Input</b>			
Current.....	2-21		
Power.....	2-3, 2-6, 3-1, 8-3, 9-1, 1-4		
Signal.....	5-1		
Signals.....	2-24		
Terminals.....	2-24, 8-4		
Voltage.....	3-2, 8-1		
<b>Installation</b>			
Installation.....	1-3, 2-5, 3-1, 8-3, 3-2		
Site.....	2-1		
<b>Isolated Line Power</b> .....	2-21		
<b>L</b>			
<b>Leakage Current (&gt;3.5 MA)</b> .....	2-6		
<b>Lifting</b> .....	2-2		

<b>P</b>		<b>Short Circuit</b> .....	8-6
<b>Parameter Settings</b> .....	4-3	<b>Smart Application Set-up (SAS)</b> .....	3-2
<b>PELV</b> .....	2-22, 6-1, 10-6	<b>Specifications</b> .....	1-3
<b>Phase Loss</b> .....	8-4	<b>Speed Reference</b> .....	2-24, 3-4, 5-1
<b>Power</b>		<b>Start Up</b> .....	9-1
Power.....	2-6	<b>Startup</b> .....	1-3, 5-1
Connections.....	2-6	<b>Start-up</b> .....	4-4
Factor.....	1-4, 2-7, 3-1, 8-3	<b>Status</b>	
<b>Pre-Installation Check List</b> .....	2-1	Messages.....	7-1
<b>Product Overview</b> .....	1-1	Mode.....	7-1
<b>Programming</b> .....	1-3, 3-4, 4-2, 5-4, 5-9, 8-4, 3-2, 4-1, 4-3	<b>Stop Command</b> .....	7-1
<b>Protection</b>		<b>Supply Voltage</b> .....	2-22, 2-23, 8-7, 10-5
Protection.....	10-8	<b>Surroundings</b> .....	10-7
And Features.....	10-8	<b>Switching Frequency</b> .....	7-1
<b>Pulse Inputs</b> .....	10-5	<b>System Feedback</b> .....	1-3
<b>Q</b>		<b>T</b>	
<b>Quick</b>		<b>Temperature Limits</b> .....	3-1, 8-3
Menu.....	4-2, 5-1, 4-2	<b>Terminal</b>	
Set-up.....	3-2	53.....	5-1, 2-24, 5-1
<b>R</b>		54.....	2-24
<b>Ramp-down Time</b> .....	3-4	Locations D1h.....	2-8
<b>Ramp-up Time</b> .....	3-4	Locations D2h.....	2-10
<b>Reference</b> .....	0-iii, 6-1, 4-2, 5-1	Programming.....	2-24
<b>Relay Outputs</b> .....	2-23, 10-6	Programming Examples.....	5-3
<b>Remote</b>		<b>Thermistor</b>	
Commands.....	1-3	Thermistor.....	2-22, 8-5, 6-1
Programming.....	5-9	Control Wiring.....	2-22
Reference.....	7-1	<b>Torque</b>	
<b>Reset</b> .....	4-1, 4-4, 7-1, 8-4, 8-10, 10-8, 4-3	Characteristics.....	10-4
<b>Residual Current Devices (RCDs)</b> .....	2-6	For Terminals.....	10-10
<b>Restoring Default Settings</b> .....	4-4	Limit.....	3-4
<b>RFI Filter</b> .....	2-21	<b>Transient Protection</b> .....	1-4
<b>RMS Current</b> .....	1-4	<b>Trip Function</b> .....	2-5
<b>RS-485</b> .....	2-25	<b>Troubleshooting</b> .....	1-3, 9-1
<b>Run</b>		<b>U</b>	
Command.....	3-4	<b>Uploading Data To The LCP</b> .....	4-4
Permissive.....	7-1	<b>Using Shielded Control Cables</b> .....	2-22
<b>S</b>		<b>V</b>	
<b>Serial Communication</b> .....	1-3, 2-23, 4-3, 7-1, 2-25	<b>Voltage Imbalance</b> .....	8-4
<b>Setpoint</b> .....	7-1	<b>W</b>	
<b>Set-up</b> .....	4-2	<b>Warning And Alarm Definitions</b> .....	8-3
<b>Shielded</b>		<b>Wire Type And Ratings</b> .....	2-6
Cable.....	2-3, 3-1, 8-3	<b>Wiring To Control Terminals</b> .....	2-24
Control Cables.....	2-23		
Wire.....	2-5		



[www.danfoss.com/drives](http://www.danfoss.com/drives)

---

Danfoss shall not be responsible for any errors in catalogs, brochures or other printed material. Danfoss reserves the right to alter its products at any time without notice, provided that alterations to products already on order shall not require material changes in specifications previously agreed upon by Danfoss and the Purchaser. All trademarks in this material are property of the respective companies. Danfoss and the Danfoss logotype are trademarks of Danfoss A/S. All rights reserved.

---

**Danfoss Drives**

4401 N. Bell School Rd.  
Loves Park IL 61111 USA  
Phone: 1-800-432-6367  
1-815-639-8600  
Fax: 1-815-639-8000  
[www.danfossdrives.com](http://www.danfossdrives.com)

**Danfoss Drives**

8800 W. Bradley Rd.  
Milwaukee, WI 53224 USA  
Phone: 1-800-621-8806  
1-414-355-8800  
Fax: 1-414-355-6117  
[www.danfossdrives.com](http://www.danfossdrives.com)

