



Operating Instructions

VLT[®] AQUA Drive FC 202 Low Harmonic Drive



Contents

1 Introduction	4
1.1 Purpose of the Manual	4
1.2 Additional Resources	4
1.3 Product Overview	4
1.3.1 Intended Use	4
1.3.2 Working Principle	4
1.3.3 Exploded View Drawings	6
1.4 Enclosure Types and Power Ratings	14
1.5 Approvals and Certifications	14
1.5.1 Approvals	14
1.5.2 Compliance with ADN	14
2 Safety	15
2.1 Safety Symbols	15
2.2 Qualified Personnel	15
2.3 Safety Precautions	15
3 Mechanical Installation	16
3.1 Equipment Pre-Installation Checklist	16
3.2 Unpacking	16
3.2.1 Items Supplied	16
3.3 Installation Environment	16
3.3.1 Planning the Installation Site	16
3.4 Mounting	17
3.4.1 Cooling and Airflow	17
3.4.2 Lifting	18
3.4.3 Cable Entry and Anchoring	19
3.4.4 Terminal Locations for Frame Size D13	22
3.4.5 Terminal Locations for Frame Size E9	23
3.4.6 Terminal Locations for Frame Size F18	24
3.4.7 Torque	26
4 Electrical Installation	28
4.1 Safety Instructions	28
4.2 EMC Compliant Installation	28
4.2.1 EMC Interference	29
4.3 Power Connections	29
4.4 Grounding	30
4.5 Input Options	31
4.5.1 Extra Protection (RCD)	31

4.5.2 RFI Switch	31
4.5.3 Shielded Cables	31
4.6 Motor Connection	31
4.6.1 Motor Output Connection	31
4.6.2 Motor Cable	31
4.6.3 Brake Cable	32
4.6.4 Brake Resistor Temperature Switch	32
4.6.5 Motor Insulation	32
4.6.6 Motor Bearing Currents	32
4.6.7 Motor Thermal Protection	33
4.7 AC Mains Connection	33
4.7.1 Mains Connection	33
4.7.2 External Fan Supply	33
4.7.3 Power and Control Wiring for Unscreened Cables	34
4.7.4 Mains Disconnects	35
4.7.5 F-Frame Circuit Breakers	35
4.7.6 F-Frame Mains Contactors	35
4.8 Control Wiring	35
4.8.1 Control Cable Routing	35
4.8.2 Access to Control Terminals	36
4.8.3 Electrical Installation, Control Terminals	36
4.8.4 Electrical Installation, Control Cables	38
4.9 Additional Connections	39
4.9.1 Mechanical Brake Control	39
4.9.2 Parallel Connection of Motors	39
4.9.3 F-frame Options	39
4.10 Final Set-up and Test	41
5 Commissioning	43
5.1 Safety Instructions	43
5.2 Applying Power	45
5.3 Local Control Panel Operation	45
5.3.1 Local Control Panel	45
5.3.2 LCP Layout	45
5.3.4 Uploading/Downloading Data to/from the LCP	47
5.3.5 Changing Parameter Settings	47
5.3.6 Restoring Default Settings	47
5.4 Basic Programming	47
5.4.1 Commissioning with SmartStart	47
5.4.2 Commissioning via [Main Menu]	48
5.4.3 Asynchronous Motor Set-up	48

5.4.4 Permanent Magnet Motor Set-up	49
5.4.5 Automatic Energy Optimisation (AEO)	50
5.4.6 Automatic Motor Adaptation (AMA)	50
5.5 Checking Motor Rotation	51
5.6 Local-control Test	51
5.7 System Start-up	51
6 Application Examples	52
6.1 Introduction	52
6.2 Application Examples	52
7 Diagnostics and Troubleshooting	56
7.1 Status Messages	56
7.2 Warning and Alarm Types	58
7.2.1 Warnings	58
7.2.2 Alarm Trip	58
7.2.3 Alarm Trip-lock	58
7.3 Warnings and Alarm Definitions - Frequency Converter	59
7.4 Active Filter Warning and Alarm Definitions	67
7.5 Troubleshooting	72
8 Specifications	74
8.1 Power-Dependent Specifications	74
8.1.1 Mains Supply 3x380-480 V AC	74
8.1.2 Derating for Temperature	77
8.2 Mechanical Dimensions	77
8.3 General Technical Data - Frequency Converter	79
8.4 General Technical Data - Filter	83
8.5 Fuses	87
8.5.1 Fuses	87
8.5.2 Fuse Specifications	88
9 Appendix	90
9.1 Abbreviations and Conventions	90
Index	91

1 Introduction

1.1 Purpose of the Manual

The purpose of this manual is to provide information for the installation and operation of a VLT® Low Harmonic Drive. The manual includes relevant safety information for installation and operation. *Chapter 1 Introduction*, *chapter 2 Safety*, *chapter 3 Mechanical Installation*, and *chapter 4 Electrical Installation* introduce the unit function and cover proper mechanical and electrical installation procedures. There are chapters on start-up and commissioning, applications and basic troubleshooting. *Chapter 8 Specifications* provides a quick reference for ratings and dimensions, as well as other operating specifications. This manual provides a basic knowledge of the unit and explains setup and basic operation.

VLT® is a registered trademark.

1.2 Additional Resources

Other resources are available to understand advanced functions and programming.

- The *VLT® AQUA Drive FC 202 Operating Instructions* provide details on installation and operation of the frequency converter.
- The *VLT® AQUA Drive FC 202 Programming Guide* provides greater detail on working with parameters and many application examples.
- The *VLT® AQUA Drive FC 202 Design Guide* provides detailed capabilities and functionality to design motor control systems.
- Supplemental publications and manuals are available from Danfoss. See www.danfoss.com/BusinessAreas/DrivesSolutions/Documentations/Technical+Documentation.htm for listings.
- Optional equipment may change some of the procedures described. Reference the instructions supplied with those options for specific requirements. Contact the local Danfoss supplier or visit the Danfoss website: www.danfoss.com/

BusinessAreas/DrivesSolutions/Documentations/Technical+Documentation.htm, for downloads or additional information.

- The *VLT® Active Filter AAF00x Operating Instructions* provide additional information about the filter portion of the Low Harmonic Drive.

1.3 Product Overview

1.3.1 Intended Use

A frequency converter (also called a drive) is an electronic motor controller that converts DC into a variable AC waveform output. The frequency and voltage of the output are regulated to control the motor speed or torque. The frequency converter can vary the speed of the motor in response to system feedback, such as with position sensors on a conveyor belt. The frequency converter can also regulate the motor by responding to remote commands from external controllers.

The frequency converter

- monitors the system and motor status
- issues warnings or alarms for fault conditions
- starts and stops the motor
- optimises energy efficiency

Operation and monitoring functions are available as status indications to an outside control system or serial communication network.

A Low Harmonic Drive (LHD) is a single unit that combines the frequency converter with an advanced active filter (AAF) for harmonic mitigation. The frequency converter and filter are 2 separate pieces packaged together in an integrated system, but each functions independently. In this manual, there are separate specifications for the frequency converter and the filter. Since the frequency converter and filter are together in the same enclosure, the unit is transported, installed, and operated as a single entity.

1.3.2 Working Principle

The VLT Low Harmonic Drive is a high-power frequency converter with an integrated active filter. An active filter is a device that actively monitors harmonic distortion levels and injects compensative harmonic current onto the line to cancel the harmonics.

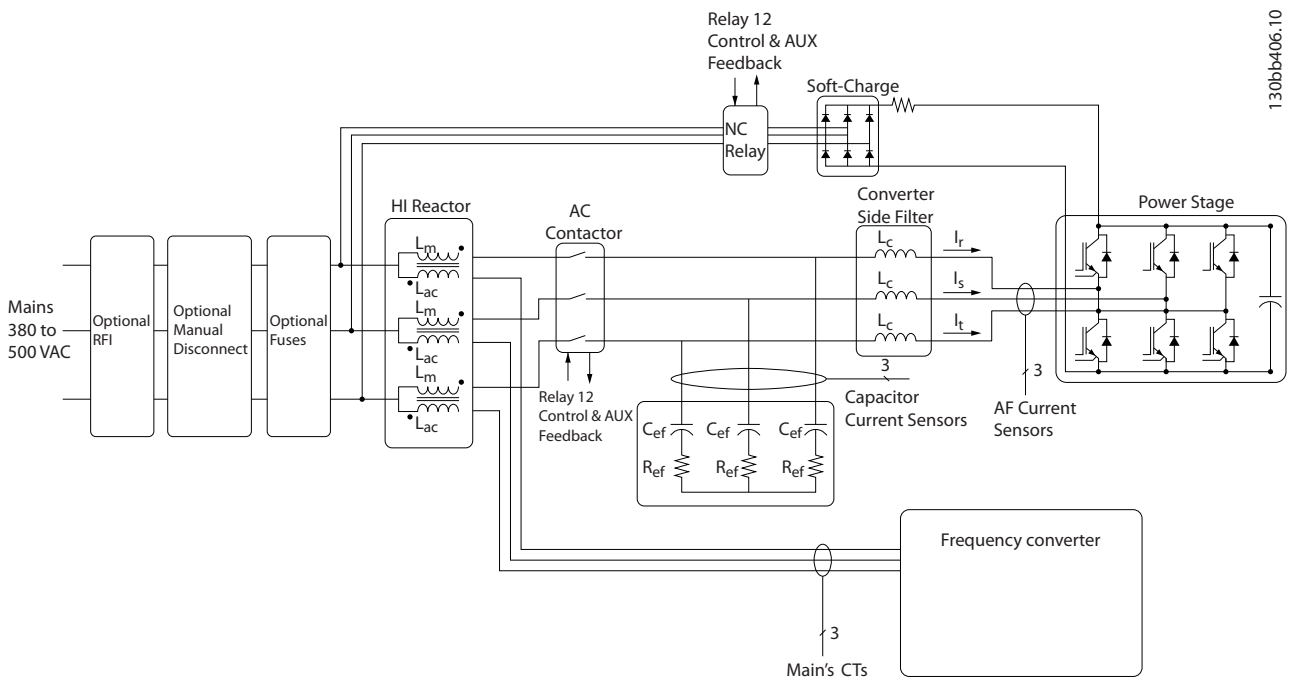

130b406.10

Illustration 1.1 Basic Layout for the Low Harmonic Drive

Low Harmonic Drives are designed to draw an ideal sinusoidal current waveform from the supply grid with a power factor of 1. Where traditional non-linear load draws pulse-shaped currents, the Low Harmonic Drive compensates that via the parallel filter path, lowering the stress on the supply grid. The Low Harmonic Drive meets the highest harmonic standards with a THiD less than 5% at full load for <3% pre-distortion on a 3% unbalanced 3-phase grid.

1.3.3 Exploded View Drawings

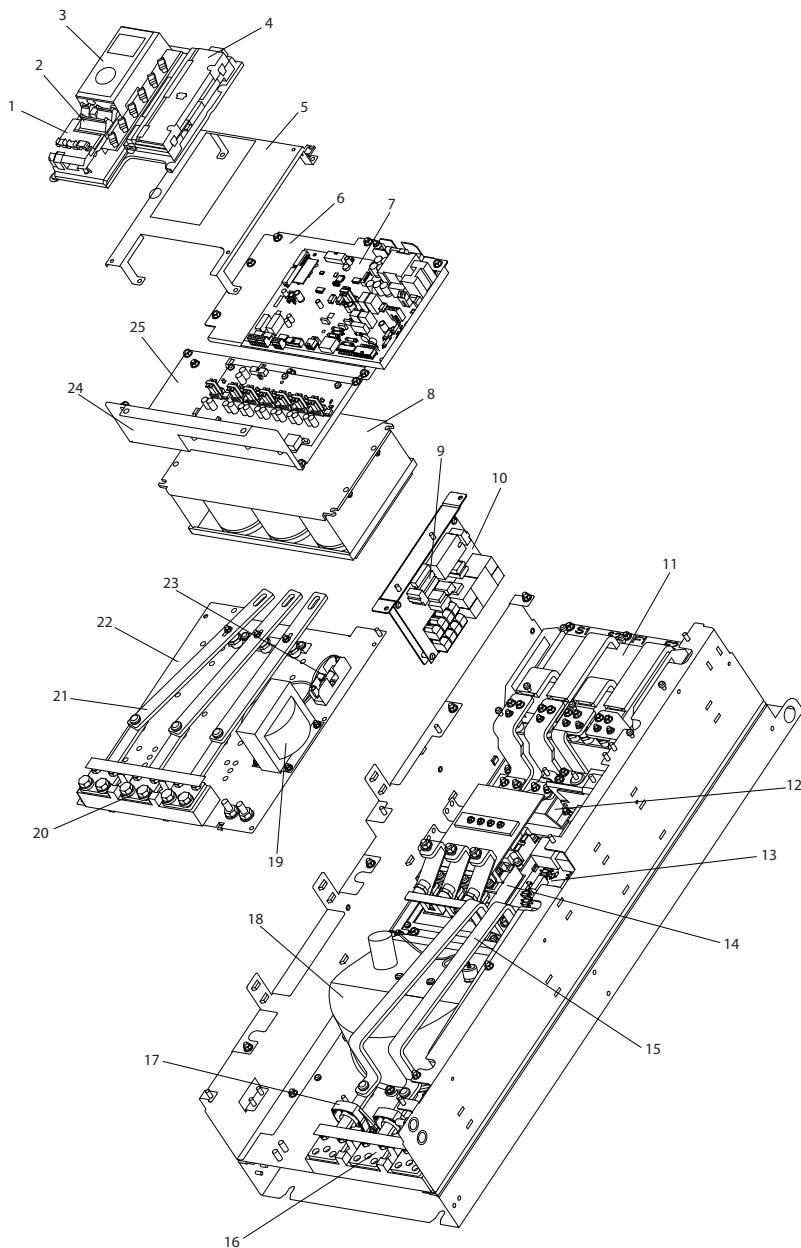

1.308BX1 67.10

1	Control card	14	SCR/diode module
2	Control input terminals	15	IGBT output bus bar
3	Local control panel (LCP)	16	Output motor terminals
4	Control card C option	17	Current sensor
5	Mounting bracket	18	Fan assembly
6	Power card mounting plate	19	Fan transformer
7	Power card	20	AC input terminals
8	Capacitor bank assembly	21	AC input bus bar
9	Soft charge fuses	22	Input terminal mounting plate assembly
10	Soft charge card	23	Fan fuse
11	DC inductor	24	Capacitor bank cover plate
12	Soft charge module	25	IGBT gate drive card
13	IGBT module		

Illustration 1.2 Frame Size D13 Drive Enclosure

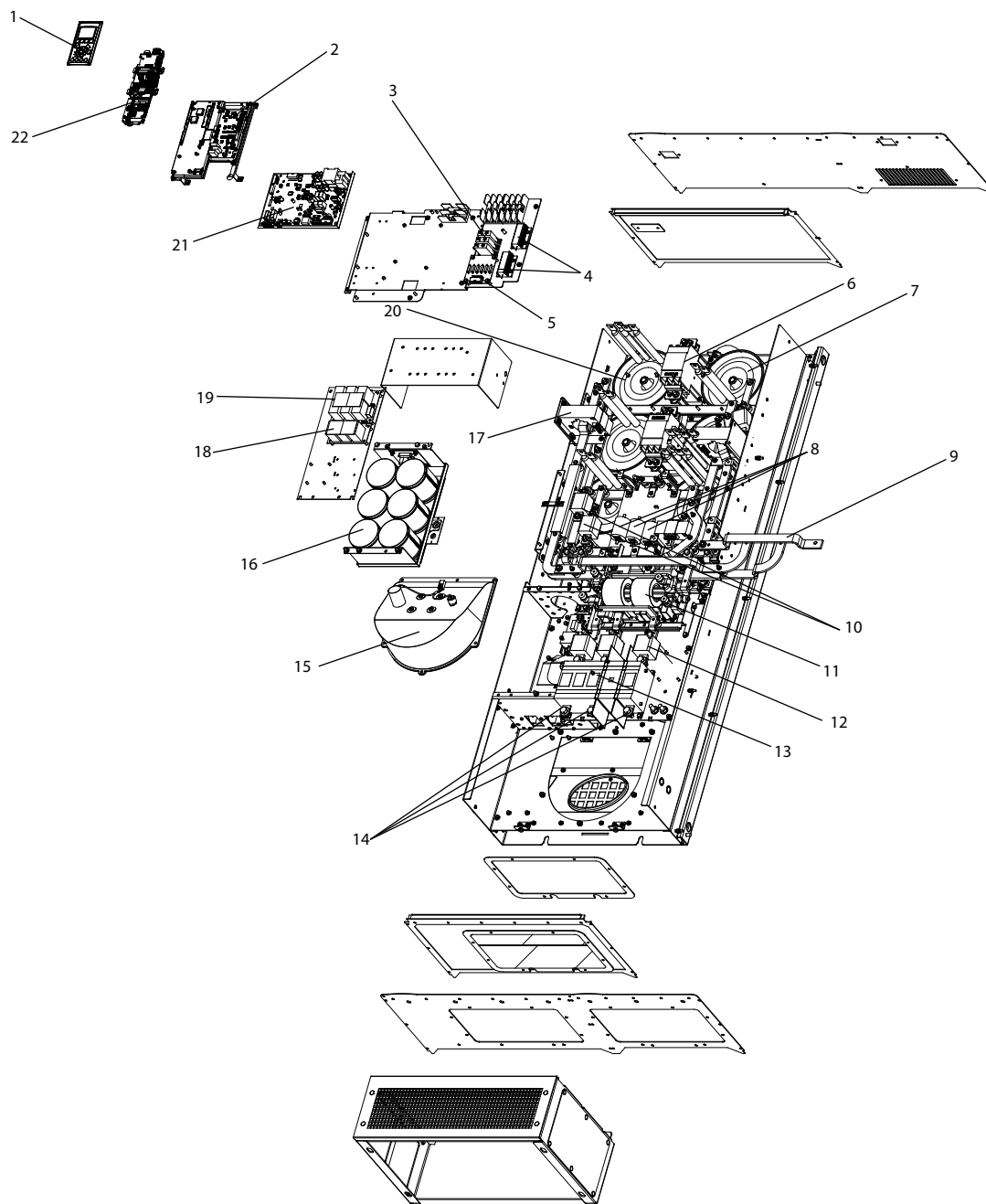

1	Local control panel (LCP)	13	Mains fuses
2	Active filter card (AFC)	14	Mains disconnect
3	Metal oxide varistor (MOV)	15	Mains terminals
4	Soft charge resistors	16	Heat sink fan
5	AC capacitors discharge board	17	DC capacitor bank
6	Mains contactor	18	Current transformer
7	LC inductor	19	RFI differential mode filter
8	AC capacitors	20	RFI common mode filter
9	Mains bus bars to drive input	21	HI inductor
10	IGBT fuses	22	Power card
11	RFI		

Illustration 1.3 Frame Size D13 Filter Enclosure

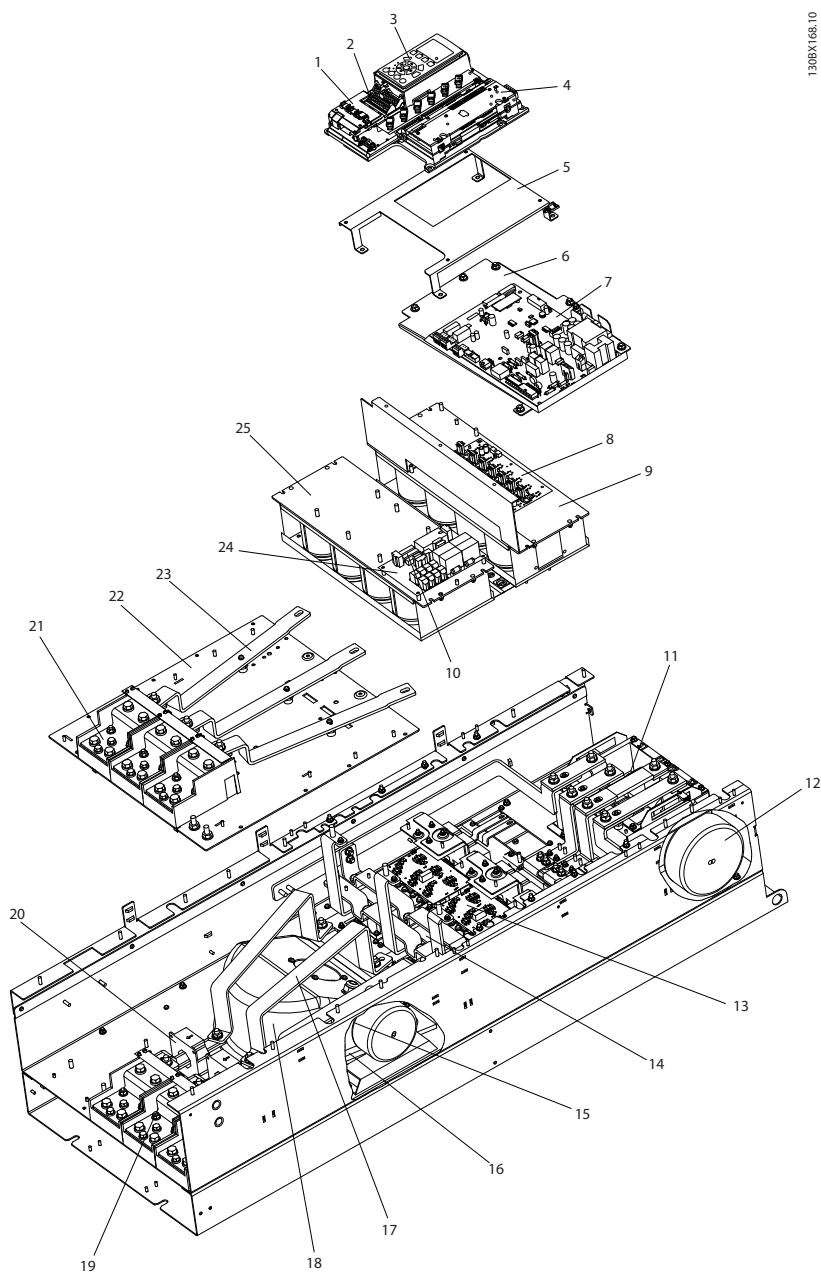

1308X168.10

1	Control card	14	SCR and diode
2	Control input terminals	15	Fan inductor (not on all units)
3	Local control panel (LCP)	16	Soft charge resistor assembly
4	Control card C option	17	IGBT output bus bar
5	Mounting bracket	18	Fan assembly
6	Power card mounting plate	19	Output motor terminals
7	Power card	20	Current sensor
8	IGBT gate drive card	21	Mains AC power input terminals
9	Upper capacitor bank assembly	22	Input terminal mounting plate
10	Soft charge fuses	23	AC input bus bar
11	DC inductor	24	Soft charge card
12	Fan transformer	25	Lower capacitor bank assembly
13	IGBT module		

Illustration 1.4 Frame Size E9 Drive Enclosure

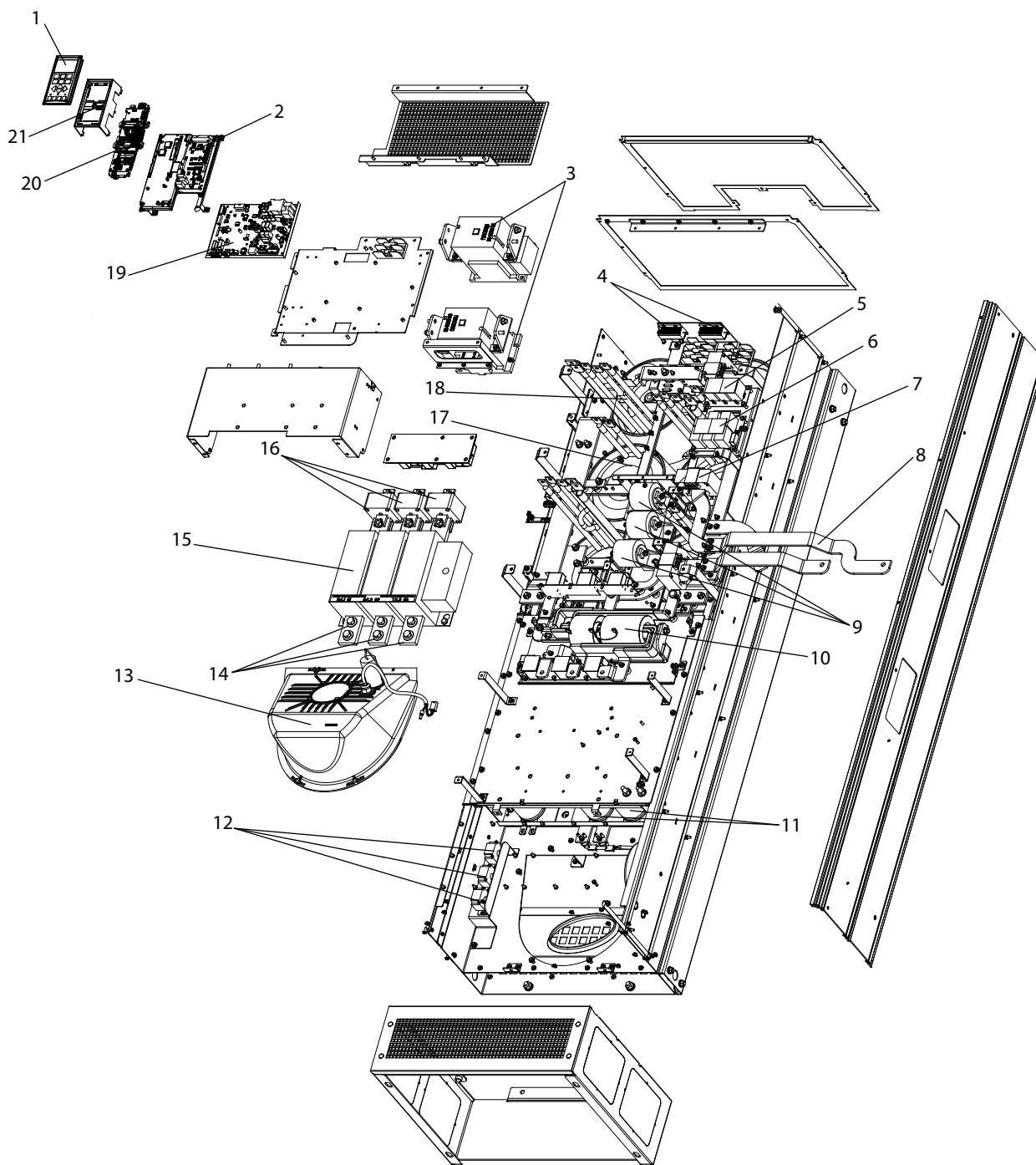

1	Local control panel (LCP)	12	AC capacitor current transducers
2	Active filter card (AFC)	13	Heat sink fan
3	Mains contactors	14	Mains terminals
4	Soft charge resistors	15	Mains disconnect
5	RFI differential mode filter	16	Mains fuses
6	RFI common mode filter	17	LC inductor
7	Current transformer (CT)	18	HI inductor
8	Mains bus bars to drive output	19	Power card
9	AC capacitors	20	Control card
10	RFI	21	LCP cradle
11	Lower DC capacitor bank		

Illustration 1.5 Frame Size E9 Filter Enclosure

1

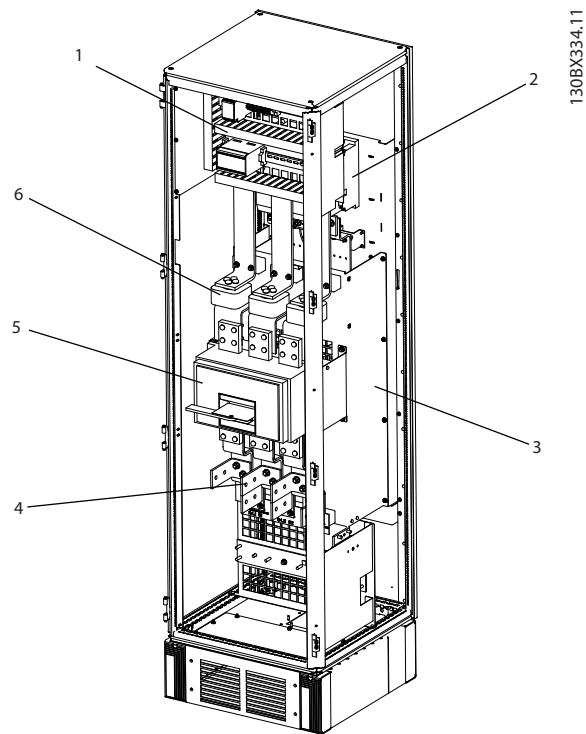

1	Contactor	4	Circuit breaker or disconnect (if purchased)
2	RFI filter	5	AC mains/line fuses (if purchased)
3	Mains AC power input terminals		

Illustration 1.6 Frame Size F18 Input Options Cabinet

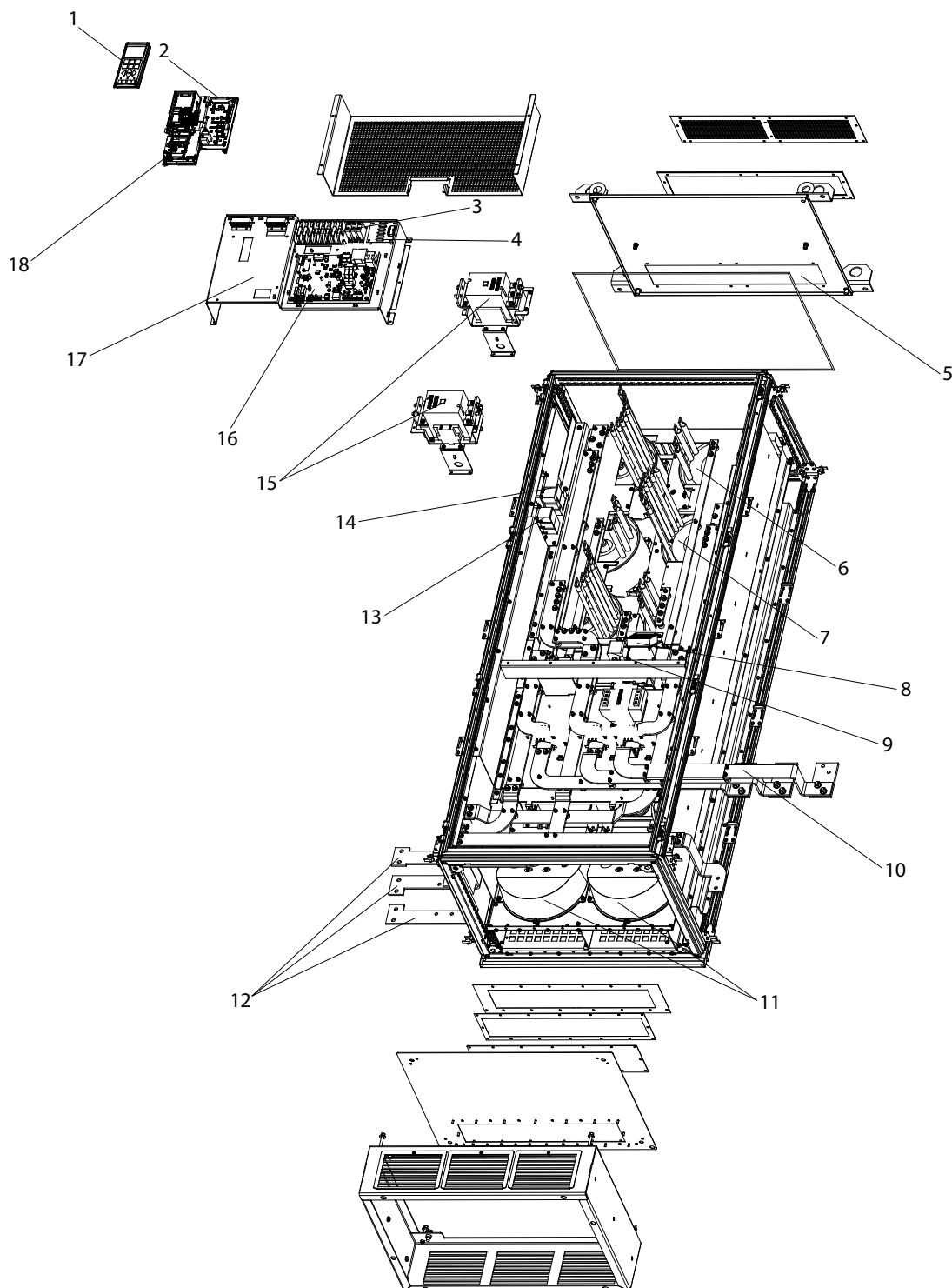

1	Local control panel (LCP)	10	Mains bus bars to drive input
2	Active filter card (AFC)	11	Heat sink fans
3	Soft charge resistors	12	Mains terminals (R/L1, S/L2, T/L3) from options cabinet
4	Metal oxide varistor (MOV)	13	RFI differential mode filter
5	AC capacitors discharge board	14	RFI common mode filter
6	LC inductor	15	Mains contactor
7	HI inductor	16	Power card
8	Mixing fan	17	Control card
9	IGBT fuses	18	LCP cradle

Illustration 1.7 Frame Size F18 Filter Cabinet

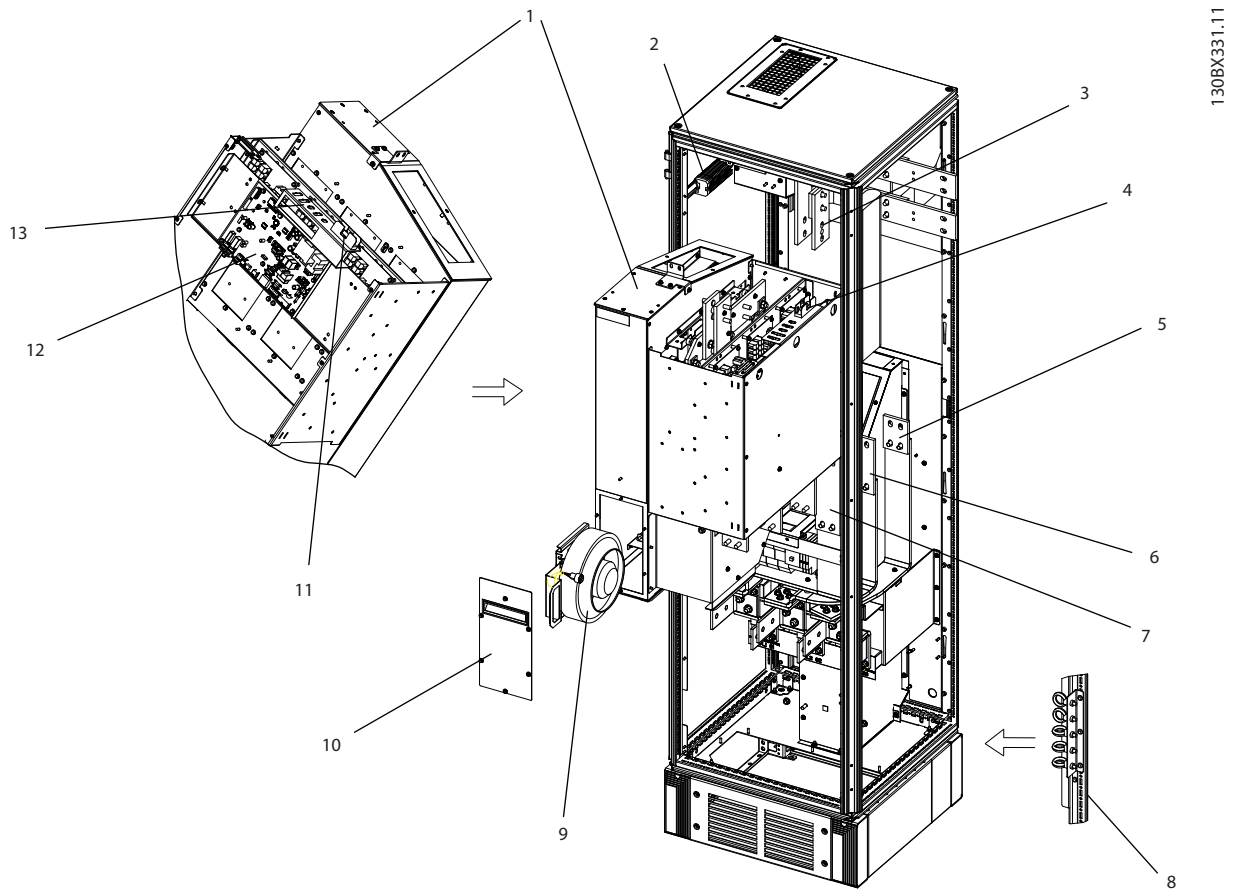

1	Rectifier module	7	Module lifting eye bolts (mounted on a vertical strut)
2	DC bus bar	8	Module heat sink fan
3	SMPS fuse	9	Fan door cover
4	(Optional) back AC fuse mounting bracket	10	SMPS fuse
5	(Optional) middle AC fuse mounting bracket	11	Power card
6	(Optional) front AC fuse mounting bracket	12	Panel connectors

Illustration 1.8 Frame Size F18 Rectifier Cabinet

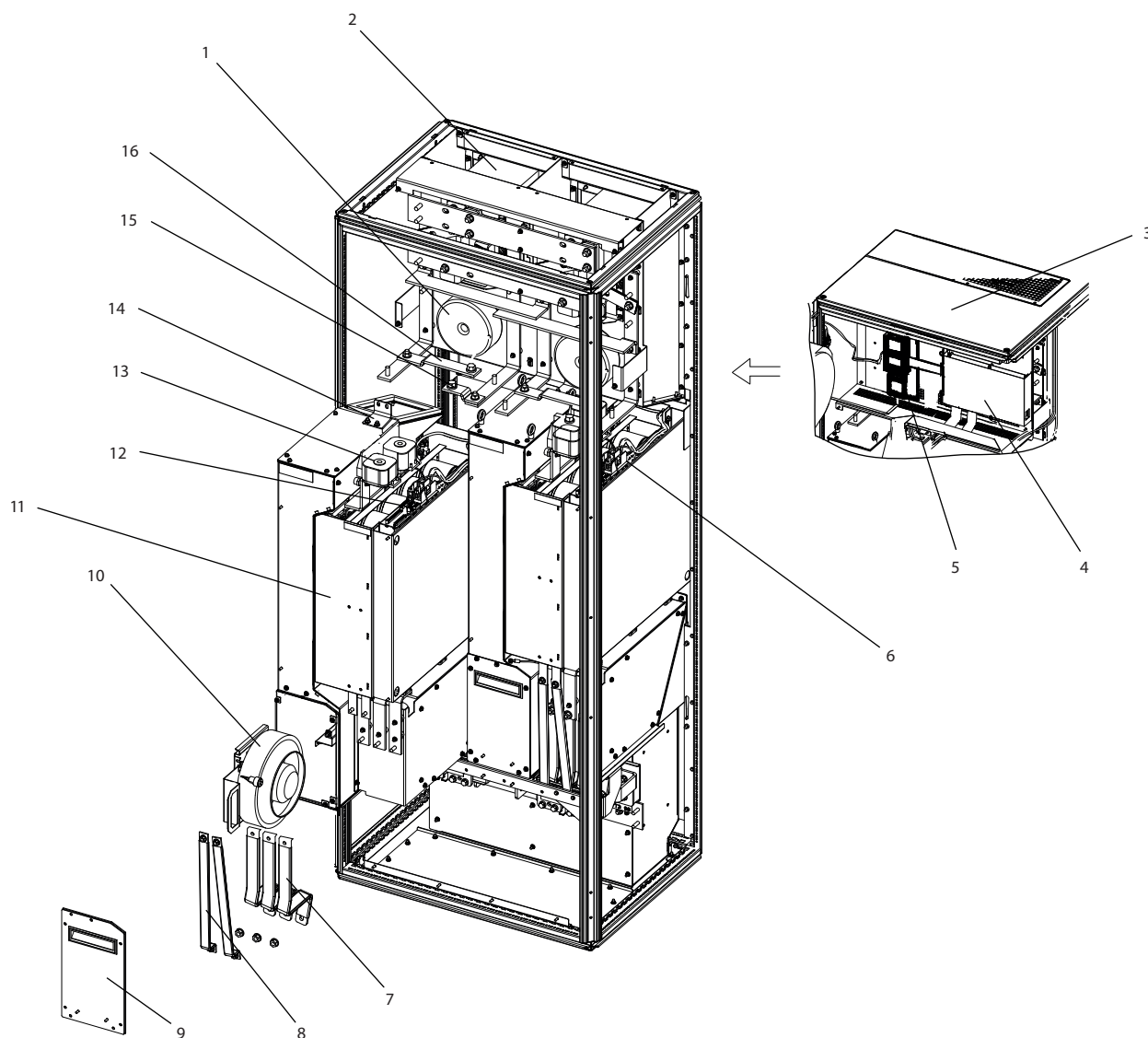

1	Fan transformer	9	Fan door cover
2	DC link inductor	10	Module heat sink fan
3	Top cover plate	11	Inverter module
4	MDCIC board	12	Panel connectors
5	Control card	13	DC fuse
6	SMPS fuse and fan fuse	14	Mounting bracket
7	Motor output bus bar	15	(+) DC bus bar
8	Brake output bus bar	16	(-) DC bus bar

Illustration 1.9 Frame Size F18 Inverter Cabinet

1.4 Enclosure Types and Power Ratings

Frame size		D13	E9	F18
Enclosure protection	IP	21/54	21/54	21/54
	NEMA	Type 1/Type 12	Type 1/Type 12	Type 1/Type 12
Drive dimensions [mm/inch]	Height	1780.5/70.1	2000.7/78.77	2278.4/89.70
	Width	1021.9 mm/40.23	1200/47.24	2792/109.92
	Depth	377.8/14.87	493.5/19.43	605.8/23.85
Drive dimensions [kg/lbs]	Max Weight	390/860	676/1490	1900/4189
	Shipping Weight	454/1001	840/1851	2345/5171

Table 1.1 Mechanical Dimensions and Rated Power, D, E and F Frames

1.5 Approvals and Certifications

1.5.1 Approvals

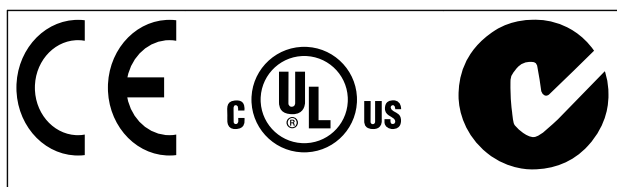

Table 1.2 Compliance Marks: CE, UL, and C-Tick

1.5.2 Compliance with ADN

For compliance with the European Agreement concerning International Carriage of Dangerous Goods by Inland Waterways (ADN), refer to *ADN-compliant Installation* in the *Design Guide*.

2 Safety

2.1 Safety Symbols

The following symbols are used in this document:

⚠ WARNING

Indicates a potentially hazardous situation which could result in death or serious injury.

⚠ CAUTION

Indicates a potentially hazardous situation which could result in minor or moderate injury. It may also be used to alert against unsafe practices.

NOTICE

Indicates important information, including situations that may result in damage to equipment or property.

2.2 Qualified Personnel

Correct and reliable transport, storage, installation, operation and maintenance are required for the safe operation of the frequency converter. Only qualified personnel are allowed to install or operate this equipment.

Qualified personnel is defined as trained staff, who are authorised to install, commission, and maintain equipment, systems and circuits in accordance with pertinent laws and regulations. Additionally, qualified personnel are familiar with the instructions and safety measures described in this document.

2.3 Safety Precautions

⚠ WARNING

HIGH VOLTAGE

Frequency converters contain high voltage when connected to AC mains input power. Qualified personnel only should perform installation, start up, and maintenance. Failure to perform installation, start up, and maintenance by qualified personnel could result in death or serious injury.

⚠ WARNING

UNINTENDED START

When the frequency converter is connected to AC mains, the motor may start at any time. The frequency converter, motor, and any driven equipment must be in operational readiness. Failure to be in operational readiness when the frequency converter is connected to AC mains could result in death, serious injury, equipment, or property damage.

⚠ WARNING

DISCHARGE TIME

Frequency converters contain DC-link capacitors that can remain charged even when the frequency converter is not powered. To avoid electrical hazards, disconnect AC mains, any permanent magnet type motors, and any remote DC-link power supplies, including battery backups, UPS, and DC-link connections to other frequency converters. Wait for the capacitors to fully discharge before performing any service or repair work. The amount of wait time is listed in the *Discharge Time* table. Failure to wait the specified time after power has been removed before doing service or repair could result in death or serious injury.

Voltage [V]	Power range [kW]	Minimum waiting time (minutes)
380-500	160-250 kW*	20
	315-710 kW	40

Table 2.1 Discharge Times

*Power ranges are for normal overload operation.

3 Mechanical Installation

3

3.1 Equipment Pre-Installation Checklist

- Before unpacking the frequency converter, examine the packaging for signs of damage. If the unit is damaged, refuse delivery and immediately contact the shipping company to claim the damage.
- Before unpacking the frequency converter, locate it as close as possible to the final installation site
- Compare the model number on the nameplate to what was ordered to verify the proper equipment
- Ensure each of the following are rated for the same voltage:
 - Mains (power)
 - Frequency converter
 - Motor
- Ensure the output current rating is equal to or greater than the motor full load current for peak motor performance.
 - Motor size and frequency converter power must match for proper overload protection.
 - If frequency converter rating is less than that of the motor, full motor output is impossible.

3.2 Unpacking

3.2.1 Items Supplied

Items supplied may vary according to product configuration.

- Make sure the items supplied and the information on the nameplate correspond to the order confirmation.
- Check the packaging and the frequency converter visually for damage caused by inappropriate handling during shipment. File any claim for damage with the carrier. Retain damaged parts for clarification.

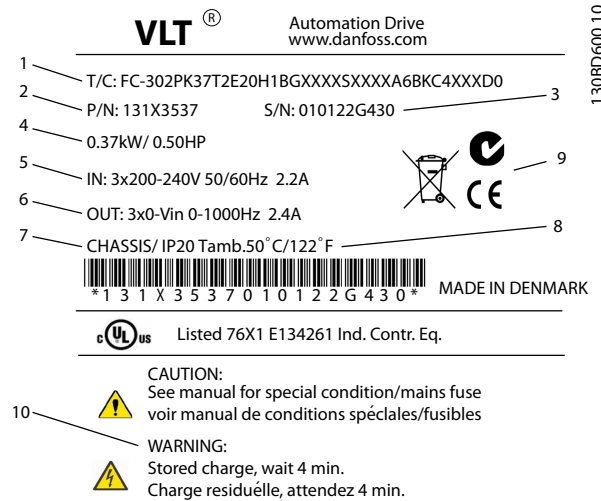

1	Type code
2	Order number
3	Serial number
4	Power rating
5	Input voltage, frequency and current (at low/high voltages)
6	Output voltage, frequency and current (at low/high voltages)
7	Enclosure type and IP rating
8	Maximum ambient temperature
9	Certifications
10	Discharge time (Warning)

Illustration 3.1 Product Nameplate (Example)

NOTICE

Do not remove the nameplate from the frequency converter (loss of warranty).

3.3 Installation Environment

3.3.1 Planning the Installation Site

Select the best possible operation site by considering the following (see details on the following pages, and in the *Design Guide*):

- Ambient operating temperature
- Installation method
- Cooling
- Position of the unit
- Cable routing
- Voltage and current supply from power source

- Current rating within range
- Fuse ratings if not using built-in fuses

3.4 Mounting

3.4.1 Cooling and Airflow

Cooling

Cooling can be obtained in different ways, by using the cooling ducts in the bottom and the top of the unit, by taking air in and out the back of the unit or by combining the cooling possibilities.

Back cooling

The backchannel air can also be ventilated in and out the back of a Rittal TS8 enclosure for frame size F18 LHD. This offers a solution where the backchannel could take air

from outside the facility and return the heat losses outside the facility thus reducing air-conditioning requirements.

NOTICE

A door fan(s) is required on the enclosure to remove the heat losses not contained in the backchannel of the drive and any additional losses generated from other components installed inside the enclosure. The total required air flow must be calculated so that the appropriate fans can be selected. Some enclosure manufacturers offer software for performing the calculations (i.e. Rittal Therm software).

Airflow

The necessary airflow over the heat sink must be secured. The flow rate is shown in *Table 3.1*.

Enclosure protection	Frame size	Door fan/top fan airflow Total airflow of multiple fans	Heat sink fan Total airflow for multiple fans
IP21/NEMA 1 IP54/NEMA 12	D13 P160–P250 (LHD120)	3 door fans, 510 m ³ /h (300 cfm) (2+1, 3x170=510)	2 heat sink fans, 1530 m ³ /h (900 cfm) (1+1, 2x765=1530)
	E9 P315–P400 (LHD210)	4 door fans, 680 m ³ /h (400 cfm) (2+2, 4x170=680)	2 heat sink fans, 2675 m ³ /h (1574 cfm) (1+1, 1230+1445=2675)
	F18 P500–P710 (LHD330)	6 door fans, 3150 m ³ /h (1854 cfm) (6x525=3150)	5 heat sink fans, 4485 m ³ /h (2639 cfm) 2+1+2, ((2x765)+(3x985)=4485)

Table 3.1 Heat Sink Air Flow

NOTICE

For the drive section, the fan runs for the following reasons:

- AMA
- DC Hold
- Pre-Mag
- DC Brake
- 60% of nominal current is exceeded
- Specific heat sink temperature exceeded (power size dependent)
- Specific power card ambient temperature exceeded (power size dependent)
- Specific control card ambient temperature exceeded

Once the fan is started, it runs for minimum 10 minutes.

NOTICE

For the active filter, the fan runs for the following reasons:

- Active filter running
- Active filter not running, but mains current exceeding limit (power size dependent)
- Specific heat sink temperature exceeded (power size dependent)
- Specific power card ambient temperature exceeded (power size dependent)
- Specific control card ambient temperature exceeded

Once the fan is started, it runs for minimum 10 minutes.

External ducts

If additional duct work is added externally to the Rittal cabinet, the pressure drop in the ducting must be calculated. Use the charts below to derate the frequency converter according to the pressure drop.

3

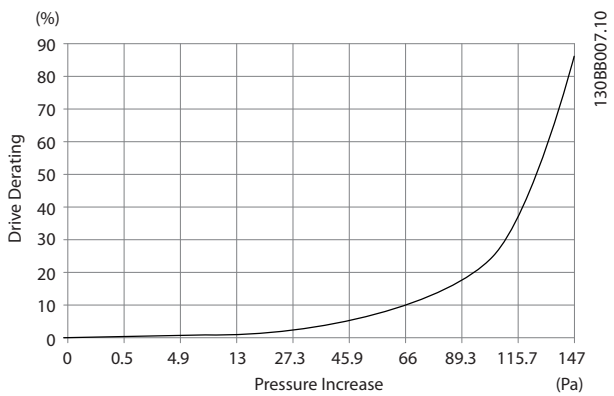

Illustration 3.2 D-Frame Derating vs. Pressure Change
 Drive Air Flow: 450 cfm (765 m³/h)

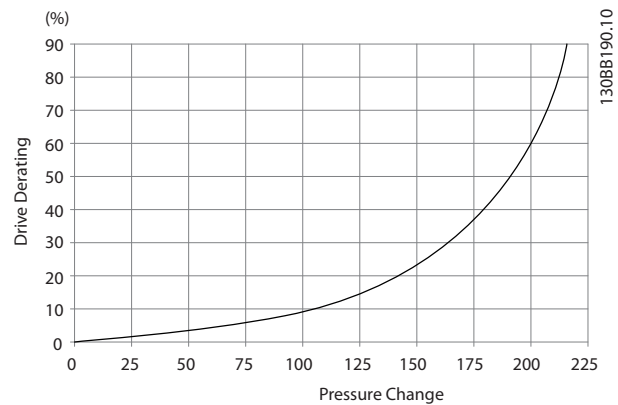

Illustration 3.5 F-Frame Derating vs. Pressure Change
 Drive Air Flow: 580 cfm (985 m³/h)

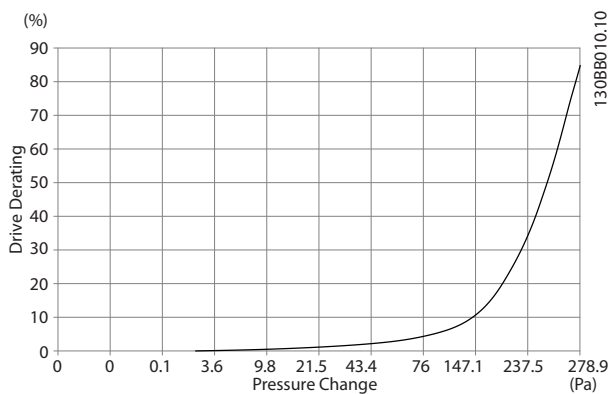

Illustration 3.3 E-Frame Derating vs. Pressure Change (Small Fan), P315
 Drive Air Flow: 650 cfm (1105 m³/h)

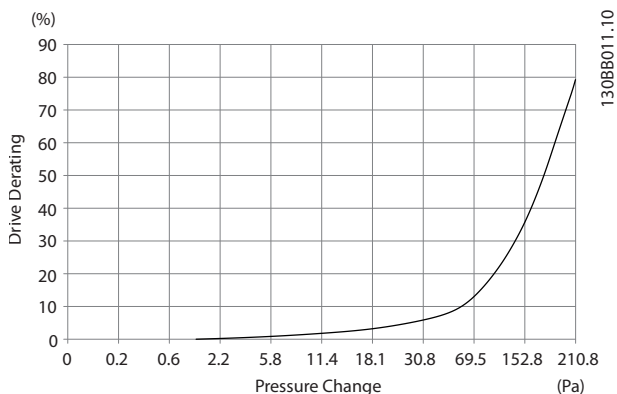

Illustration 3.4 E-Frame Derating vs. Pressure Change (Large Fan) P355-P450
 Drive Air Flow: 850 cfm (1445 m³/h)

3.4.2 Lifting

Lift the frequency converter using the dedicated lifting eyes. For all D-frames, use a bar to avoid bending the lifting holes of the frequency converter.

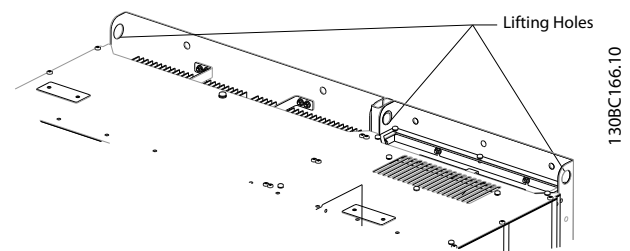

Illustration 3.6 Recommended Lifting Method, Frame Size D13

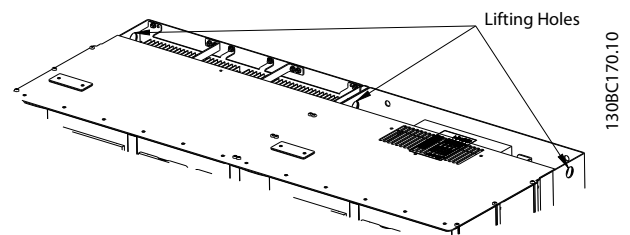
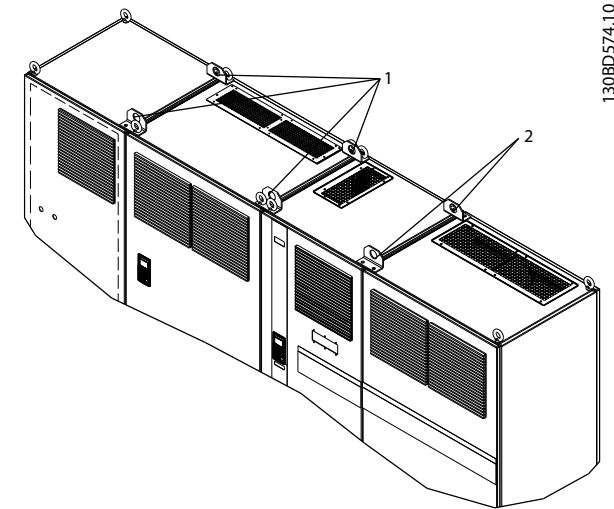

Illustration 3.7 Recommended Lifting Method, Frame Size E9

WARNING

The lifting bar must be able to handle the weight of the frequency converter. See *chapter 8.2 Mechanical Dimensions* for the weight of the different frame sizes. Maximum diameter for bar is 2.5 cm (1 inch). The angle from the top of the frequency converter to the lifting cable should be 60° or greater.



NOTICE

A spreader bar is also an acceptable way to lift the F-frame.

NOTICE

The F18 pedestal is packaged separately and included in the shipment. Mount the frequency converter on the pedestal in its final location. The pedestal allows proper airflow and cooling.

1	Lifting holes for the filter
2	Lifting holes for the frequency converter

Illustration 3.8 Recommended Lifting Method, Frame Size F18

3.4.3 Cable Entry and Anchoring

Cables enter the unit through gland plate openings in the bottom. The illustrations in this section show gland entry locations and detailed views of anchoring hole dimensions.

Bottom View, D13

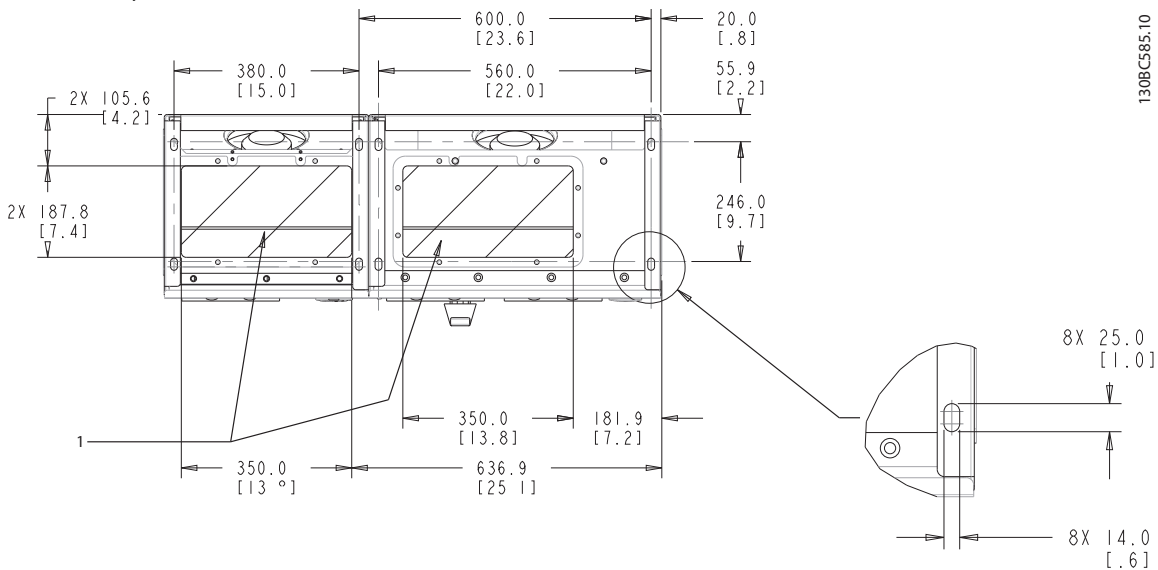

1	Cable entry locations
---	-----------------------

Illustration 3.9 Cable Entry Diagram, D13

Bottom View, E9

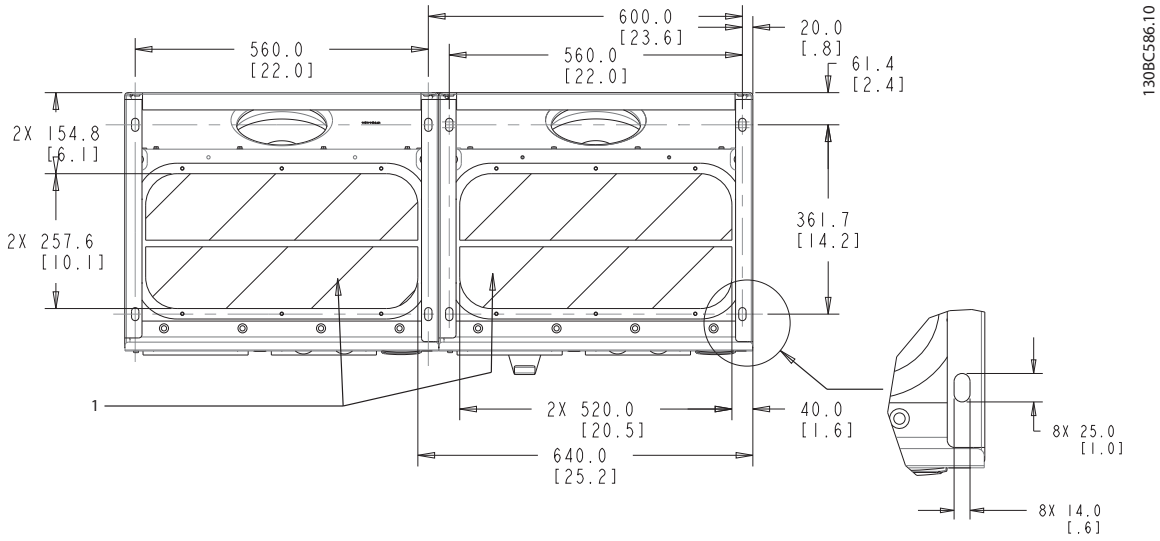

1	Cable entry locations
---	-----------------------

Illustration 3.10 Cable Entry Diagram, E9

Bottom View, F18

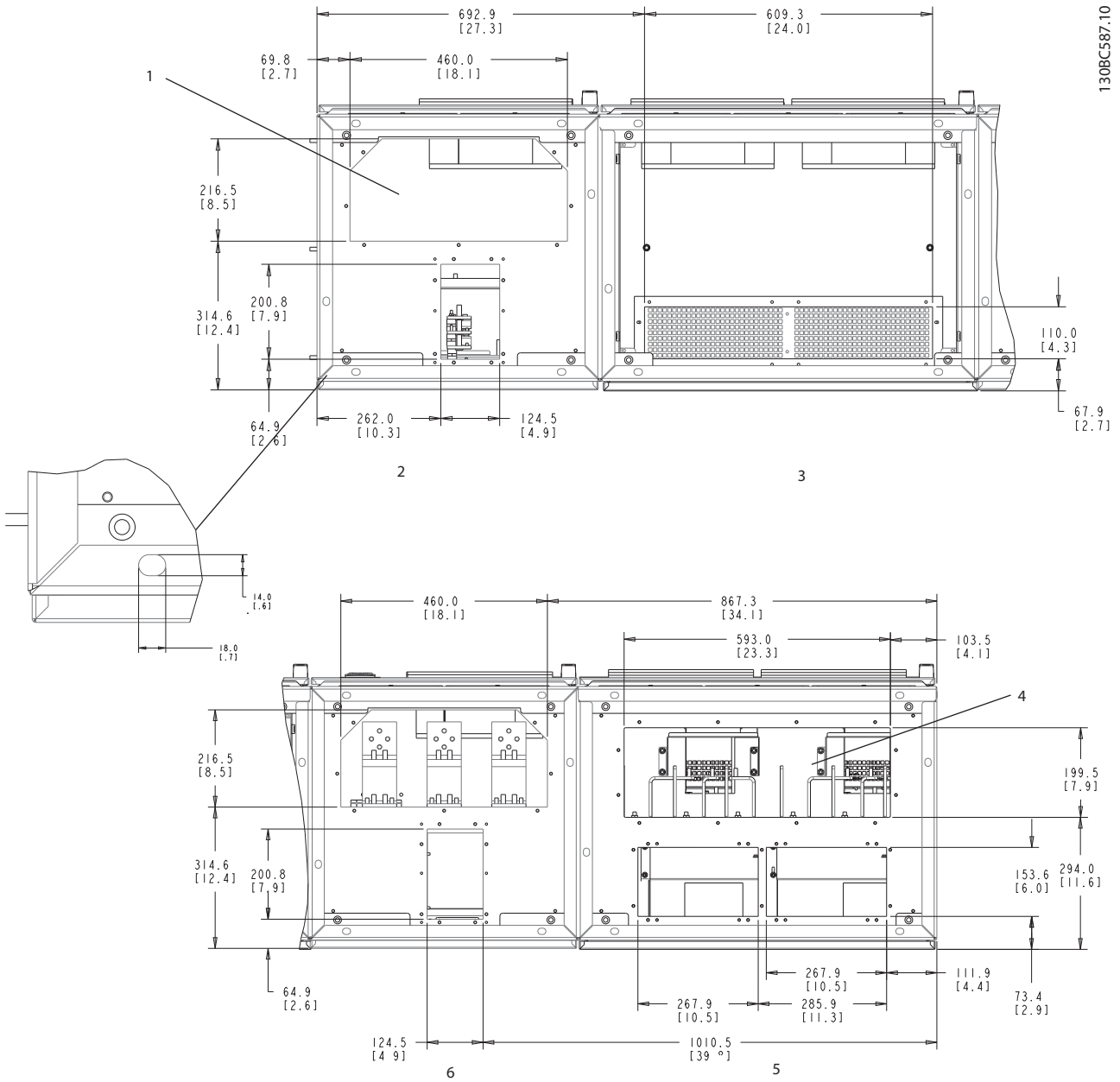

1	Mains cable entry	4	Motor cable entry
2	Option enclosure	5	Inverter enclosure
3	Filter enclosure	6	Rectifier enclosure

Illustration 3.11 Cable Entry Diagram, F18

3.4.4 Terminal Locations for Frame Size D13

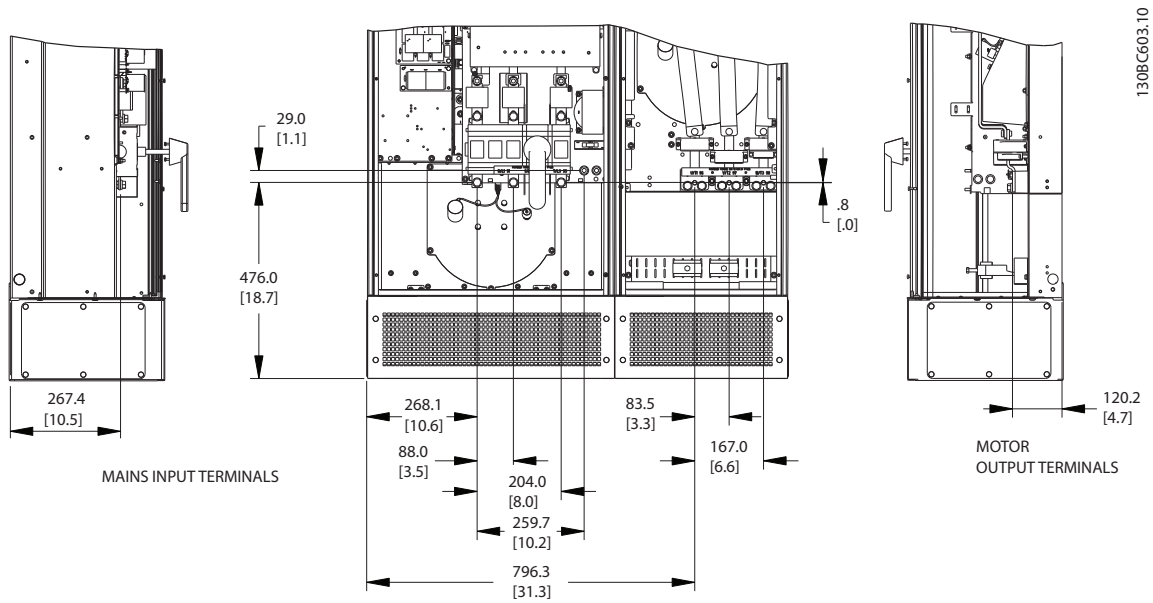

Illustration 3.12 Frame Size D13 Terminal Locations

Allow for bend radius of heavy power cables.

NOTICE

All D-frames are available with standard input terminals, fuse, or disconnect switch.

3.4.5 Terminal Locations for Frame Size E9

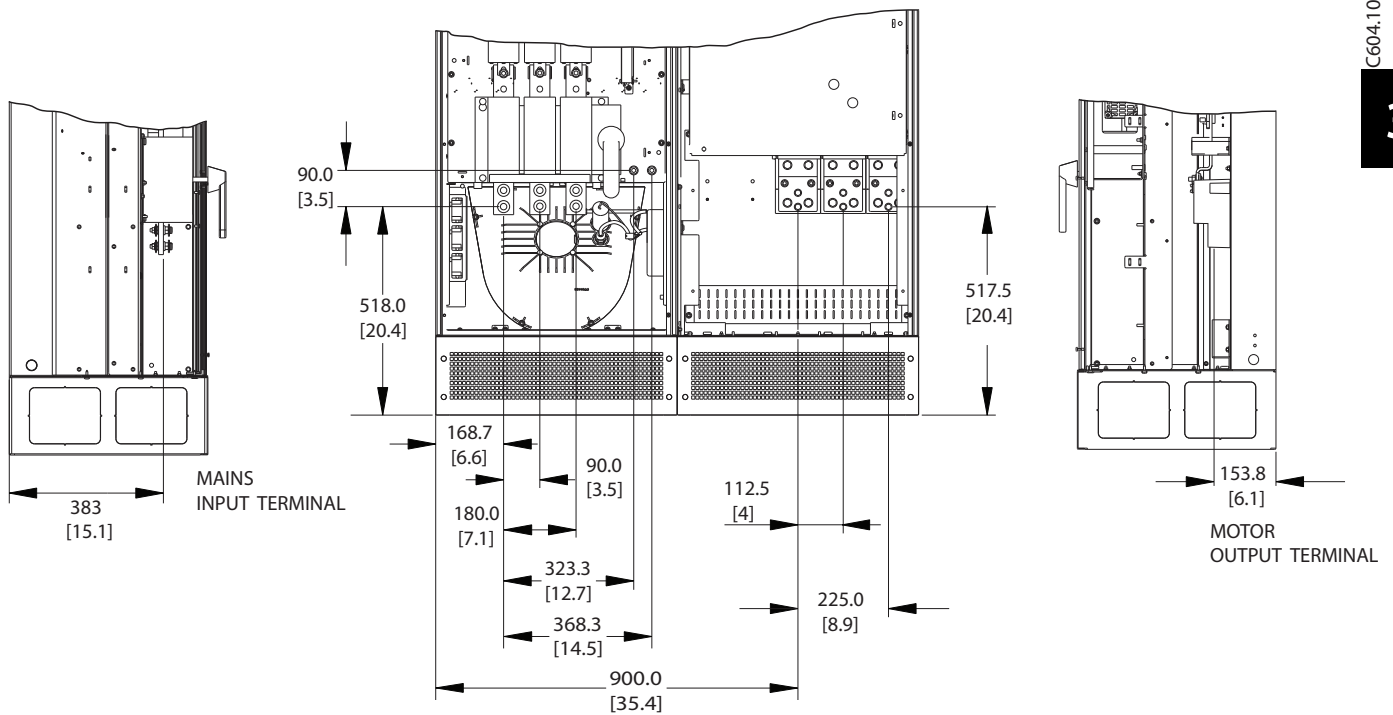

C604.10

3

Illustration 3.13 Frame Size E9 Terminal Locations

Allow for bend radius of heavy power cables.

NOTICE

All E-frames are available with standard input terminals, fuse, or disconnect switch.

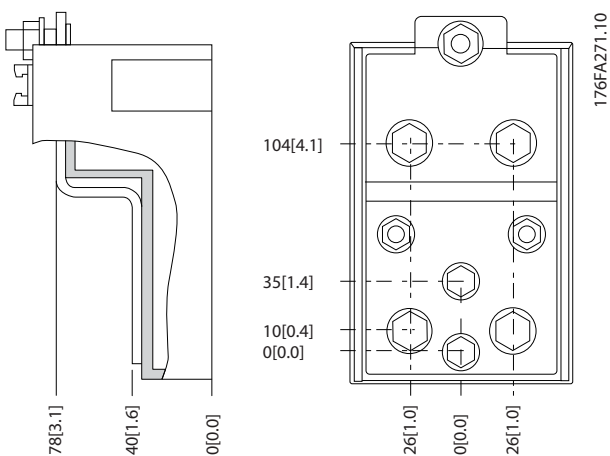

Illustration 3.14 Close-up Terminal Diagrams

3.4.6 Terminal Locations for Frame Size F18

Consider the position of the terminals when designing the cable access.

3

F-frame units have 4 interlocked cabinets:

- Input options cabinet (not optional for LHD)
- Filter cabinet
- Rectifier cabinet
- Inverter cabinet

See *chapter 1.3.3 Exploded View Drawings* for exploded views of each cabinet. Mains inputs are located in the input option cabinet, which conducts power to the rectifier via interconnecting bus bars. Output from the unit is from the inverter cabinet. No connection terminals are located in the rectifier cabinet. Interconnecting bus bars are not shown.

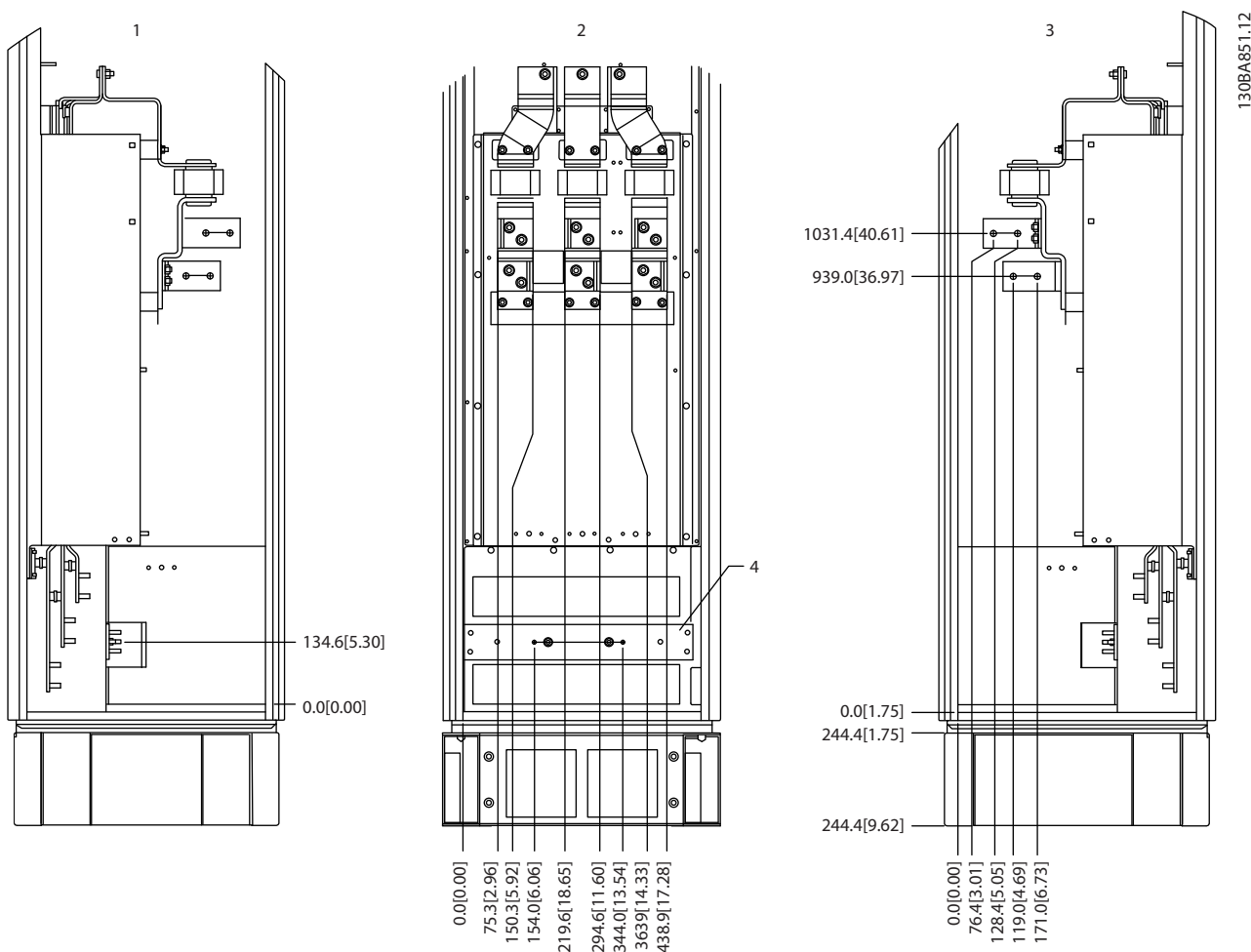

1	Right side cut-away	3	Left side cut-away
2	Front view	4	Ground bar

Illustration 3.15 Frame Size F18 Input Option Cabinet - Fuses Only

The gland plate is 42 mm below the 0 level. Shown are the left side view, front, and right.

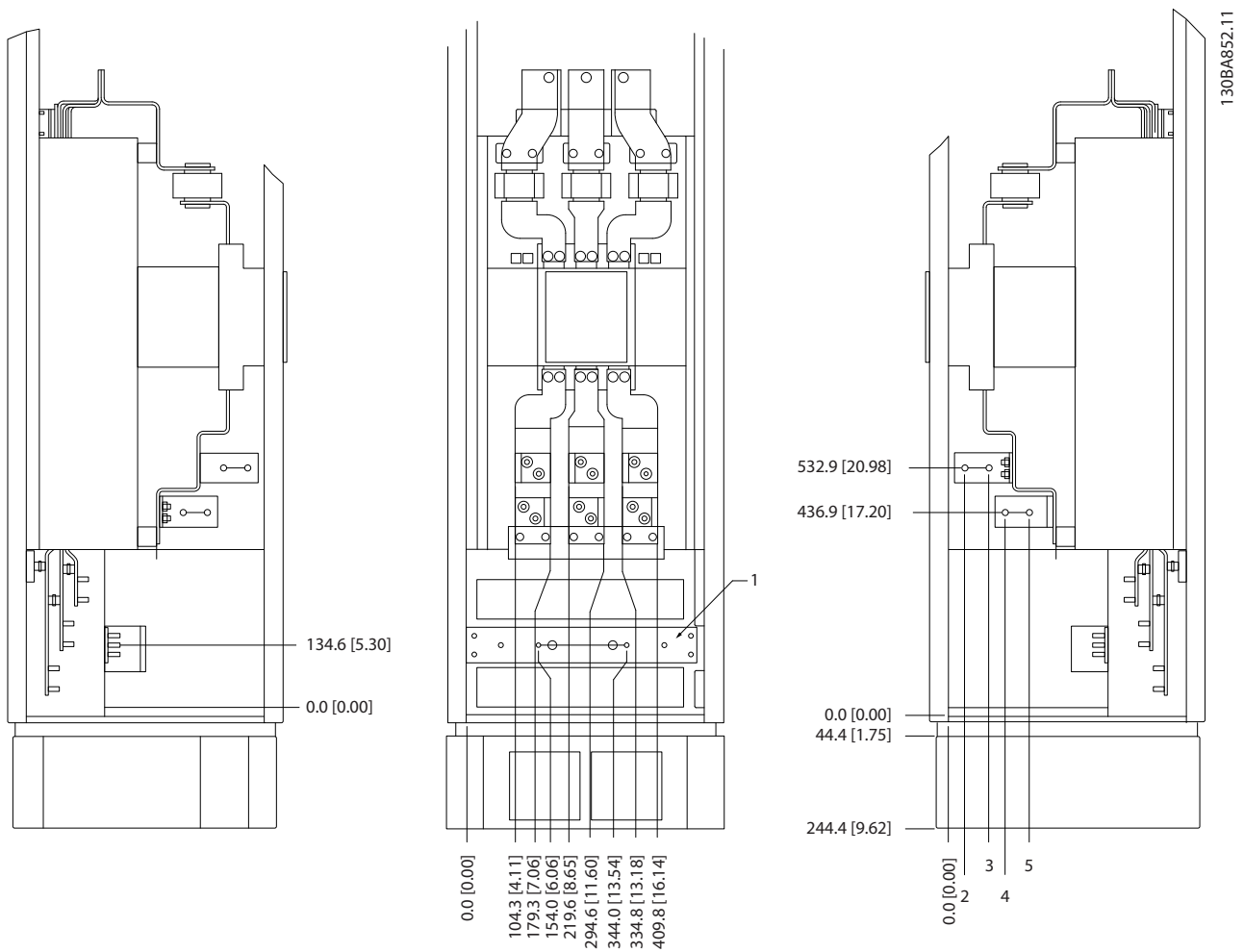

3

	500 kW* (mm [in.])	560-710 kW* (mm [in.])
1	Ground Bar	
2	34.9 [1.4]	46.3 [1.8]
3	86.9 [3.4]	98.3 [3.9]
4	122.2 [4.8]	119 [4.7]
5	174.2 [6.9]	171 [6.7]

*Disconnect location and related dimensions vary with kilowatt rating

Illustration 3.16 Frame Size F18 Input Option Cabinet with Circuit Breaker

The gland plate is 42 mm below the 0 level. Shown are the left side view, front, and right.

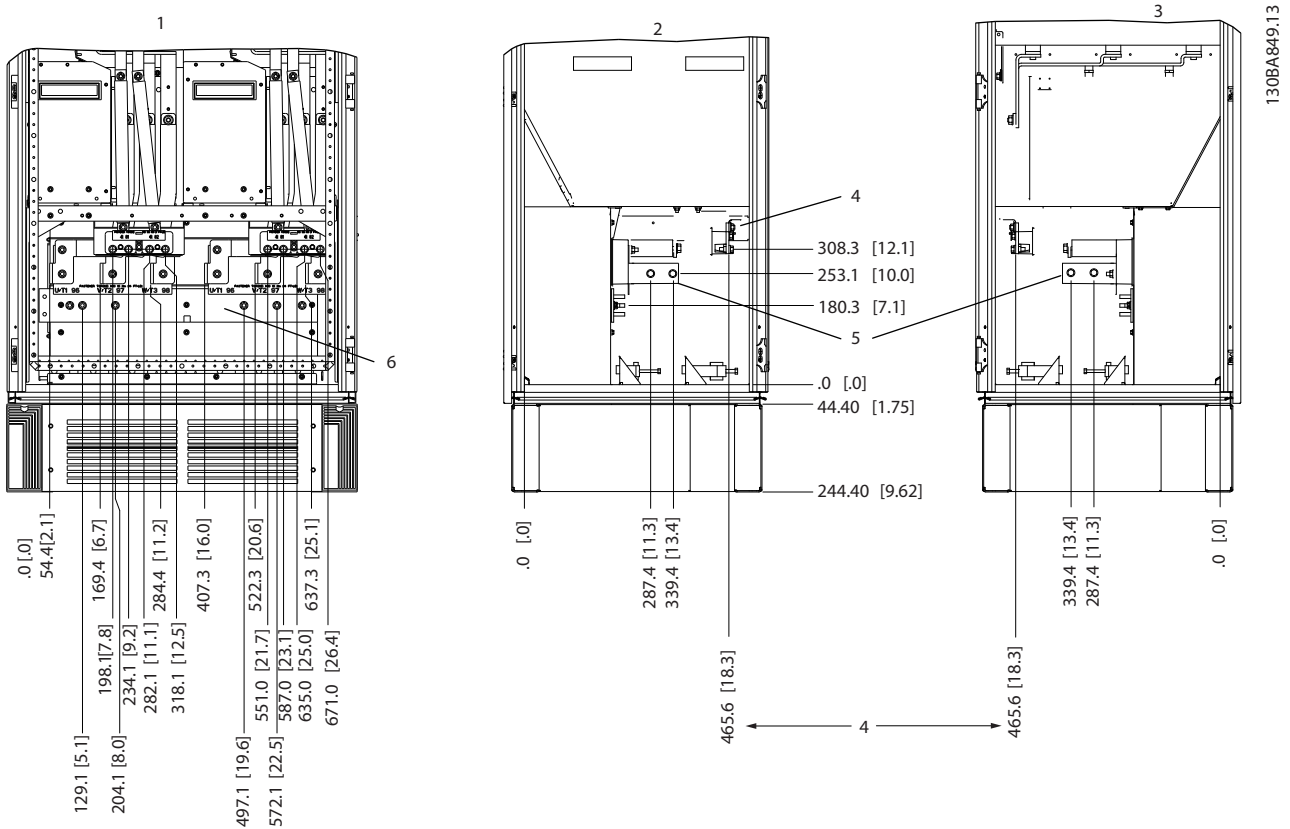

1	Front View	5	Motor output bus bar
2	Left Side View	6	Ground bar
3	Right Side View	7	Screen clamp
4	Brake Terminals		

Illustration 3.17 Frame Size F18 Inverter Cabinet

The gland plate is 42 mm below the 0 level. Shown are the left side view, front, and right.

3.4.7 Torque

Correct torque is imperative for all electrical connections. The correct values are listed in Table 3.2. Incorrect torque results in a bad electrical connection. Use a torque wrench to ensure correct torque.

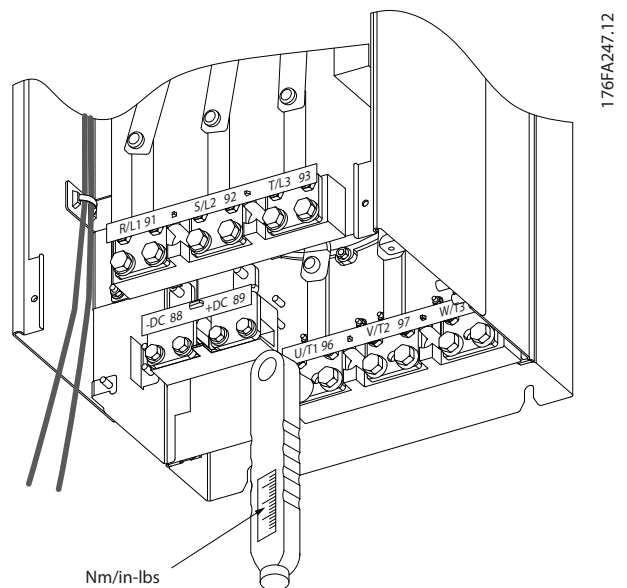

Illustration 3.18 Use a Torque Wrench to Tighten the Bolts

Frame size	Terminal	Torque [Nm] (in-lbs)	Bolt size
D	Mains Motor	19–40 (168–354)	M10
	Load sharing Brake	8.5–20.5 (75–181)	M8
E	Mains Motor Load sharing	19–40 (168–354)	M10
	Brake	8.5–20.5 (75–181)	M8
F	Mains Motor	19–40 (168–354)	M10
	Load sharing	19–40 (168–354)	M10
	Brake	8.5–20.5 (75–181)	M8
	Regen	8.5–20.5 (75–181)	M8

Table 3.2 Torque for Terminals

3

4 Electrical Installation

4.1 Safety Instructions

See *chapter 2 Safety* for general safety instructions.

⚠ WARNING

INDUCED VOLTAGE

Induced voltage from output motor cables that run together can charge equipment capacitors, even with the equipment turned off and locked out. Failure to run output motor cables separately or use screened cables could result in death or serious injury.

- Run output motor cables separately, or
- Use screened cables.

⚠ CAUTION

SHOCK HAZARD

The frequency converter can cause a DC current in the PE conductor. Failure to follow the recommendation below means the RCD may not provide the intended protection.

- When a residual current-operated protective device (RCD) is used for protection against electrical shock, only an RCD of Type B is permitted on the supply side.

Overcurrent protection

- Additional protective equipment, such as short-circuit protection or motor thermal protection between frequency converter and motor, is required for applications with multiple motors.
- Input fusing is required to provide short-circuit and overcurrent protection. If not factory-supplied, fuses must be provided by the installer. See maximum fuse ratings in *chapter 8.5 Fuses*.

Wire type and ratings

- All wiring must comply with local and national regulations regarding cross-section and ambient temperature requirements.
- Power connection wire recommendation: Minimum 75 °C rated copper wire.

See *chapter 8.1 Power-Dependent Specifications* and *chapter 8.3 General Technical Data - Frequency Converter* for recommended wire sizes and types.

4.2 EMC Compliant Installation

To obtain an EMC-compliant installation, follow the instructions provided in *chapter 4.4 Grounding*, *chapter 4.5 Input Options*, *chapter 4.6 Motor Connection*, and *chapter 4.8 Control Wiring*.

4.2.1 EMC Interference

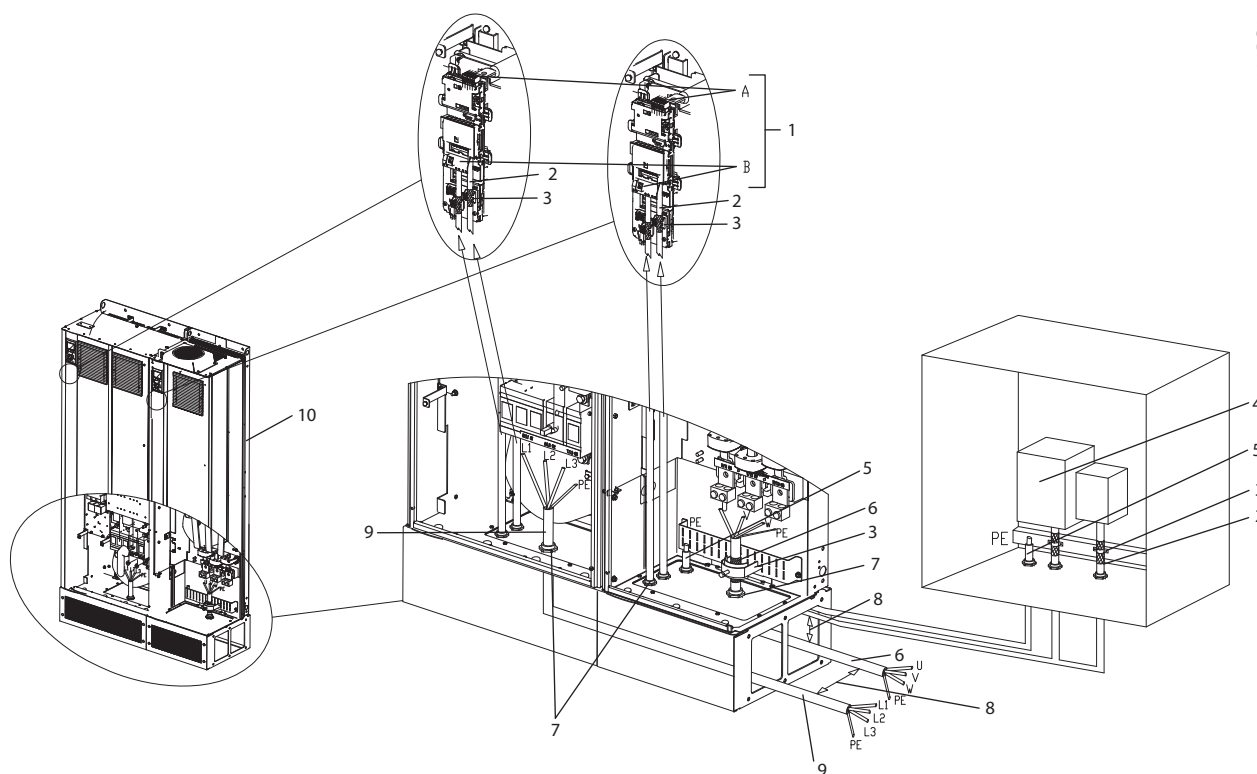

1	Customer control termination points—options A and B	6	Motor output cable, 3-phase and PE (screened)
2	Screened control wiring	7	Cable gland
3	Cable clamp	8	Clearance, minimum 200 mm
4	Customer control input	9	Mains input cable, 3-phase and reinforce PE
5	Potential equalisation wire [minimum 16 mm ²]	10	Low harmonic drive (LHD)

Illustration 4.1 EMC-correct Installation

NOTICE

EMC Interference

Use screened cables for motor and control wiring. Separate the LHD mains input cable, motor cable, and control wiring. Minimum 200 mm (7.9 in) clearance between power, motor, and control cables is required. Maximise this clearance to minimise EMC emissions. This reduces the risk of interference between the LHD and other electronic devices.

4.3 Power Connections

NOTICE

Cables—General Information

All cabling must comply with national and local regulations on cable cross-sections and ambient temperature. UL applications require 75 °C copper conductors. For non-UL applications, 75 and 90 °C copper conductors are thermally acceptable.

The power cable connections are situated as shown in *Illustration 4.2*. Dimension cable cross-section in accordance with the current ratings and local legislation. See *chapter 8.3.1 Cable lengths and cross-sections* *chapter 8.5 Fuses* for details.

For protection of the frequency converter, use the recommended fuses if there are no built-in fuses. Fuse recommendations are provided in . Ensure that proper fusing is made according to local regulation.

The mains connection is fitted to the mains switch, if included.

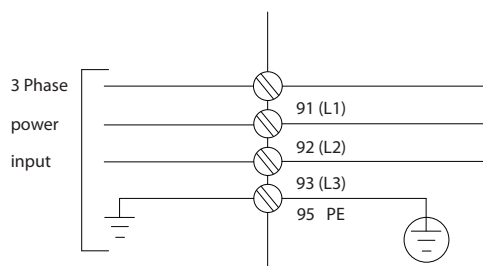

130BA026.10

Illustration 4.2 Power Cable Connections

NOTICE

To comply with EMC emission specifications, screened/armoured cables are recommended. If an unscreened/unarmoured cable is used, see chapter 4.7.3 Power and Control Wiring for Unscreened Cables.

See chapter 8 Specifications for correct dimensioning of motor cable cross-section and length.

Screening of cables

Avoid installation with twisted screen ends (pigtailed). They spoil the screening effect at higher frequencies. If breaking the screen is necessary to install a motor isolator or contactor, continue the screen at the lowest possible HF impedance.

Connect the motor cable screen to both the de-coupling plate of the frequency converter and to the metal housing of the motor.

Make the screen connections with the largest possible surface area (cable clamp). Use the installation devices within the frequency converter.

Cable-length and cross-section

The frequency converter has been EMC tested with a given length of cable. Keep the motor cable as short as possible to reduce the noise level and leakage currents.

Switching frequency

When frequency converters are used together with sine-wave filters to reduce the acoustic noise from a motor, the switching frequency must be set according to 14-01 Switching Frequency.

Term. no.	96	97	98	99	
	U	V	W	PE ¹⁾	Motor voltage 0–100% of mains voltage. 3 wires out of motor
	U1	V1	W1	PE ¹⁾	Delta-connected 6 wires out of motor
	W2	U2	V2		
	U1	V1	W1	PE ¹⁾	Star-connected U2, V2, W2 U2, V2, and W2 to be interconnected separately.

Table 4.1 Terminal Connections

1) Protective Earth Connection

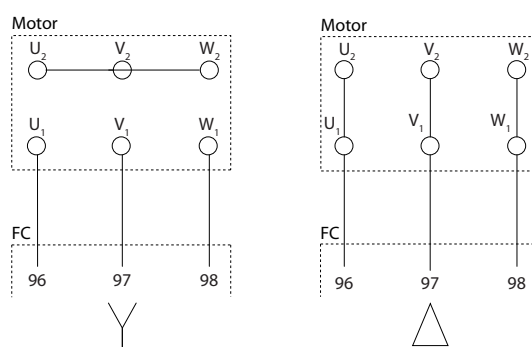

175ZA114.11

Illustration 4.3 Y and Delta Terminal Configurations

4.4 Grounding

Consider the following basic issues for electromagnetic compatibility (EMC) during installation:

- Safety grounding: The frequency converter has a high leakage current and must be grounded appropriately for safety reasons. Apply local safety regulations.
- High-frequency grounding: Keep the ground wire connections as short as possible.

Connect the different ground systems at the lowest possible conductor impedance. Keep the conductor as short as possible and use the greatest possible surface area for the lowest possible conductor impedance.

The metal cabinets of the different devices are mounted on the cabinet rear plate using the lowest possible HF impedance. Doing so avoids different HF voltages for individual devices and the risk of radio interference currents running in connection cables between the devices. The radio interference is reduced.

To obtain a low HF impedance, use the fastening bolts of the devices as HF connection to the rear plate. Remove insulating paint or similar from the fastening points.

4.5 Input Options

4.5.1 Extra Protection (RCD)

ELCB relays, multiple protective grounding, or standard grounding provide extra protection, if local safety regulations are followed.

In the case of a ground fault, a DC component develops in the fault current.

If using ELCB relays, observe local regulations. Relays must be suitable for protection of 3-phase equipment with a bridge rectifier and for a brief discharge on power-up.

4.5.2 RFI Switch

Mains supply isolated from ground

If the frequency converter is supplied from an isolated mains source or TT/TN-S mains with grounded leg, turn off the RFI switch via *14-50 RFI Filter* on both frequency converter and the filter. For further reference, see IEC 364-3. When optimum EMC performance is needed, parallel motors are connected, or the motor cable length is above 25 m, set *14-50 RFI Filter* to [ON].

In OFF, the internal RFI capacitors (filter capacitors) between the chassis and the intermediate circuit are cut off to avoid damage to the intermediate circuit and reduce ground capacity currents (IEC 61800-3).

Refer to the application note *VLT on IT mains*. It is important to use isolation monitors that work together with power electronics (IEC 61557-8).

4.5.3 Shielded Cables

It is important to connect shielded cables properly to ensure high EMC immunity and low emissions.

Connection can be made using either cable glands or clamps:

- EMC cable glands: Generally available cable glands can be used to ensure an optimum EMC connection.
- EMC cable clamp: Clamps allowing easy connection are supplied with the unit.

4.6 Motor Connection

4.6.1 Motor Output Connection

4.6.2 Motor Cable

Connect the motor to terminals U/T1/96, V/T2/97, W/T3/98, on the far right of the unit. Ground to terminal 99. All types of 3-phase asynchronous standard motors can be used with a frequency converter. The factory setting is for

clockwise rotation with the frequency converter output connected as follows:

Terminal No.	Function
96, 97, 98	Mains U/T1, V/T2, W/T3
99	Ground

Table 4.2 Terminal Functions

- Terminal U/T1/96 connected to U-phase
- Terminal V/T2/97 connected to V-phase
- Terminal W/T3/98 connected to W-phase

The direction of rotation can be changed by switching 2 phases in the motor cable or by changing the setting of *4-10 Motor Speed Direction*.

Motor rotation check can be performed via *1-28 Motor Rotation Check* and following the steps shown in the display.

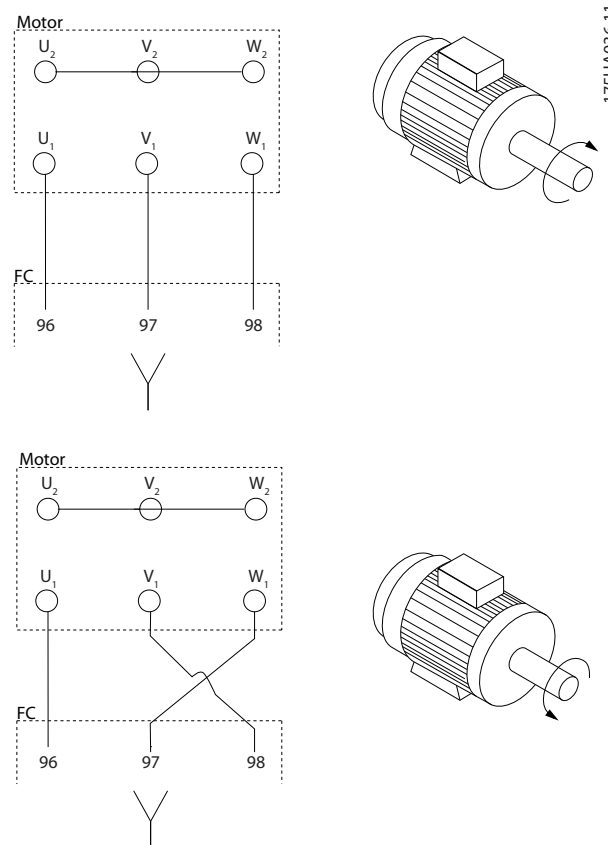

Illustration 4.4 Motor Rotation Check

F-frame requirements

Use motor phase cables in quantities of 2, resulting in 2, 4, 6, or 8 to obtain an equal number of wires on both inverter module terminals. The cables are required to be equal length within 10% between the inverter module

terminals and the first common point of a phase. The recommended common point is the motor terminals.

Output junction box requirements

The length, minimum 2.5 m, and quantity of cables must be equal from each inverter module to the common terminal in the junction box.

NOTICE

If a retrofit application requires an unequal number of wires per phase, consult the factory or use the top/bottom entry side cabinet option, instruction 177R0097.

4.6.3 Brake Cable

Frequency converters with factory installed brake chopper option

(Only standard with letter B in position 18 of type code).

The connection cable to the brake resistor must be screened and the max. length from frequency converter to the DC bar is limited to 25 m.

Terminal No.	Function
81, 82	Brake resistor terminals

Table 4.3 Terminal Functions

The connection cable to the brake resistor must be screened. Connect the screen with cable clamps to the conductive back plate of the frequency converter and the metal cabinet of the brake resistor.

Size the brake cable cross-section to match the brake torque.

!WARNING

Note that voltages up to 790 V DC, depending on the supply voltage, are possible on the terminals.

F-frame requirements

The brake resistors must be connected to the brake terminals in each inverter module.

4.6.4 Brake Resistor Temperature Switch

The input for the brake resistor temperature switch can be used to monitor the temperature of an externally connected brake resistor. If the connection between 104 and 106 is removed, the frequency converter trips on warning/alarm 27, Brake IGBT.

Install a Klixon switch that is 'normally closed' in series with the existing connection on either 106 or 104. Any connection to this terminal must be double insulated against high voltage to maintain PELV.

Normally closed: 104–106 (factory installed jumper).

Terminal No.	Function
106, 104, 105	Brake resistor temperature switch.

Table 4.4 Terminal Functions

!CAUTION

If the temperature of the brake resistor is too high and the thermal switch drops out, the frequency converter stops braking. The motor coasts.

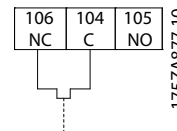

Illustration 4.5 Factory-installed Jumper

4.6.5 Motor Insulation

For motor cable lengths ≤ the maximum cable length, the motor insulation ratings listed in Table 4.5 are recommended. The peak voltage can be twice the DC-link voltage or 2.8 times mains voltage, due to transmission line effects in the motor cable. If a motor has lower insulation rating, use a dU/dt or sine wave filter.

Nominal Mains Voltage	Motor Insulation
$U_N \leq 420 \text{ V}$	Standard $U_{LL} = 1,300 \text{ V}$
$420 \text{ V} < U_N \leq 500 \text{ V}$	Reinforced $U_{LL} = 1,600 \text{ V}$

Table 4.5 Recommended Motor Insulation Ratings

4.6.6 Motor Bearing Currents

Motors with a rating 110 kW or higher combined with frequency converters are best with NDE (Non-Drive End) insulated bearings to eliminate circulating bearing currents caused by motor size. To minimise DE (Drive End) bearing and shaft currents, proper grounding is required for:

- Frequency converter
- Motor
- Motor-driven machine
- Motor to the driven machine

Although failure due to bearing currents is infrequent, use the following strategies to reduce the likelihood:

- Use an insulated bearing
- Apply rigorous installation procedures
- Ensure that the motor and load motor are aligned
- Strictly follow the EMC Installation guideline

- Reinforce the PE so the high frequency impedance is lower in the PE than the input power leads
- Provide a good high frequency connection between the motor and the frequency converter
- Ensure that the impedance from frequency converter to building ground is lower than the grounding impedance of the machine. Make a direct ground connection between the motor and load motor.
- Apply conductive lubrication
- Try to ensure that the line voltage is balanced to ground.
- Use an insulated bearing as recommended by the motor manufacturer (note: Motors from reputable manufacturers typically have insulated bearings as standard in motors of this size)

If found to be necessary and after consultation with Danfoss:

- Lower the IGBT switching frequency
- Modify the inverter waveform, 60° AVM vs. SFAVM
- Install a shaft grounding system or use an isolating coupling between motor and load
- Use minimum speed settings if possible
- Use a dU/dt or sine-wave filter

4.6.7 Motor Thermal Protection

The electronic thermal relay in the frequency converter has received UL-approval for single motor protection, when *1-90 Motor Thermal Protection* is set for *ETR Trip* and *1-24 Motor Current* is set to the rated motor current (see the motor name plate).

For thermal motor protection, it is also possible to use the MCB 112 PTC Thermistor Card option. This card provides ATEX certificate to protect motors in explosion hazardous areas, Zone 1/21 and Zone 2/22. When *1-90 Motor Thermal Protection*, set to [20] *ATEX ETR*, is combined with the use of MCB 112, it is possible to control an Ex-e motor in explosion hazardous areas. Consult the *Programming Guide* for details on how to set up the frequency converter for safe operation of Ex-e motors.

4.7 AC Mains Connection

4.7.1 Mains Connection

Mains must be connected to terminals 91, 92 and 93 on the far left of the unit. Ground is connected to the terminal on the right of terminal 93.

Terminal No.	Function
91, 92, 93	Mains R/L1, S/L2, T/L3
94	Ground

Table 4.6 Terminal Functions

Ensure that the power supply can supply the necessary current to the frequency converter.

If the unit is without built-in fuses, ensure that the appropriate fuses have the correct current rating.

4.7.2 External Fan Supply

If the frequency converter is supplied by DC or the fan must run independently of the power supply, use an external power supply. Make the connection on the power card.

Terminal No.	Function
100, 101	Auxiliary supply S, T
102, 103	Internal supply S, T

Table 4.7 Terminal Functions

The connector on the power card provides the connection of line voltage for the cooling fans. The fans are connected from the factory to be supplied from a common AC line (jumpers between 100–102 and 101–103). If external power supply is needed, remove the jumpers and connect the supply to terminals 100 and 101. Protect with a 5 A fuse. In UL applications, use a Littelfuse KLK-5 or equivalent.

4.7.3 Power and Control Wiring for Unscreened Cables

WARNING

INDUCED VOLTAGE

Induced voltage from coupled output motor cables charges equipment capacitors even with the equipment turned off and locked out. Run motor cables from multiple frequency converters separately. Failure to run output cables separately could result in death or serious injury.

CAUTION

COMPROMISED PERFORMANCE

The frequency converter runs less efficiently if wiring is not isolated properly. To isolate high frequency noise, place the following in separate metallic conduits:

- power wiring
- motor wiring
- control wiring

Failure to isolate these connections could result in less than optimum controller and associated equipment performance.

Because the power wiring carries high frequency electrical pulses, it is important to run input power and motor power in separate conduit. If incoming power wiring is in the same conduit as motor wiring, these pulses can couple electrical noise back onto the power grid. Isolate control wiring from high-voltage power wiring.

When screened/armoured cable is not used, at least 3 separate conduits are connected to the panel options cabinet (see *Illustration 4.6*).

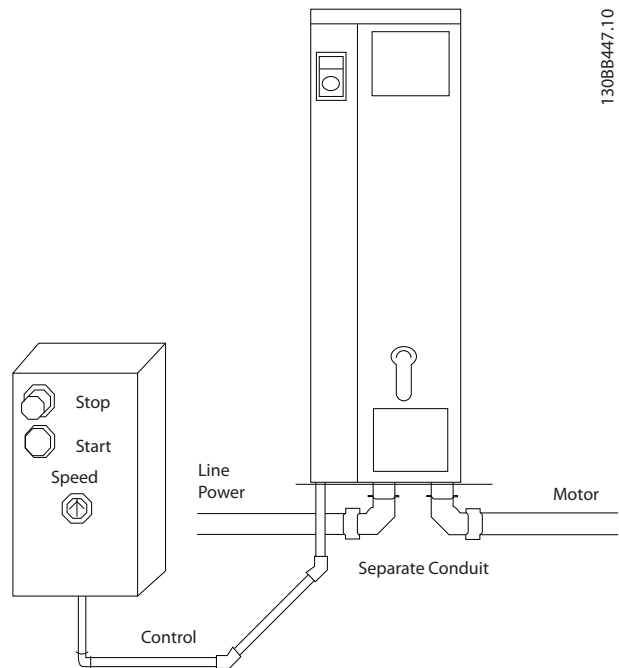

Illustration 4.6 Proper Electrical Installation Using Conduit

4.7.4 Mains Disconnects

Frame size	Power & Voltage	Type
D	P132-P200 380-500 V	OT400U12-9 or ABB OETL-NF400A
E	P250 380-500 V	ABB OETL-NF600A
E	P315-P400 380-500 V	ABB OETL-NF800A
F	P450 380-500 V	Merlin Gerin NPJF36000S12AAYP
F	P500-P630 380-500 V	Merlin Gerin NRK36000S20AAYP

Table 4.8 Recommended Mains Disconnects

4.7.5 F-Frame Circuit Breakers

Frame size	Power & Voltage	Type
F	P450 380-500 V	Merlin Gerin NPJF36120U31AABSCYP
F	P500-P630 380-500 V	Merlin Gerin NRJF36200U31AABSCYP

Table 4.9 Recommended Circuit Breakers

4.7.6 F-Frame Mains Contactors

Frame size	Power & Voltage	Type
F	P450-P500 380-500 V	Eaton XTCE650N22A
F	P560-P630 380-500 V	Eaton XTCEC14P22B

Table 4.10 Recommended Contactors

4.8 Control Wiring

4.8.1 Control Cable Routing

Tie down all control wires to the designated control cable routing as shown in *Illustration 4.7*, *Illustration 4.8*, and *Illustration 4.9*. Remember to connect the shields in a proper way to ensure optimum electrical immunity.

Fieldbus connection

Connections are made to the relevant options on the control card. For details, see the relevant fieldbus instruction. The cable must be placed in the provided path inside the frequency converter and tied down together with other control wires (see *Illustration 4.7* and *Illustration 4.8*).

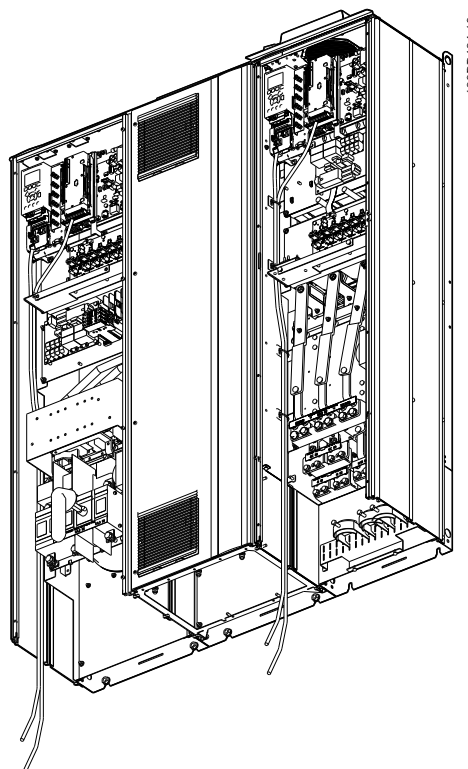

Illustration 4.7 Control Card Wiring Path for Frame Size D13

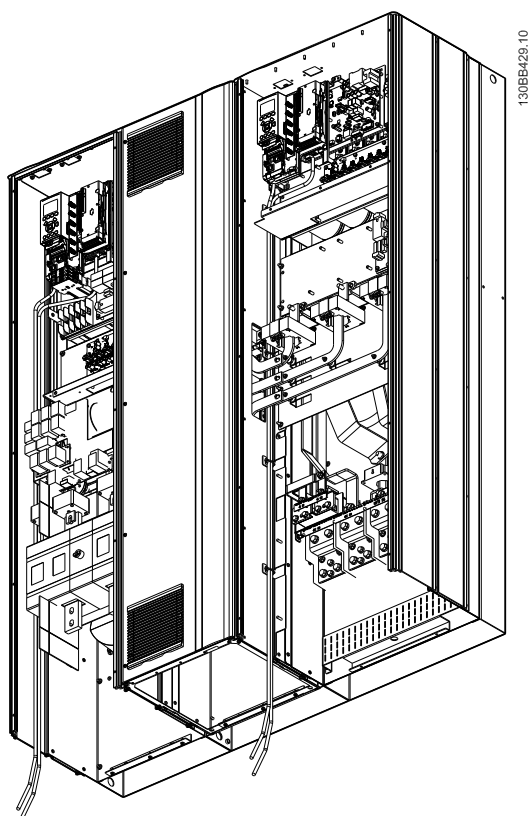
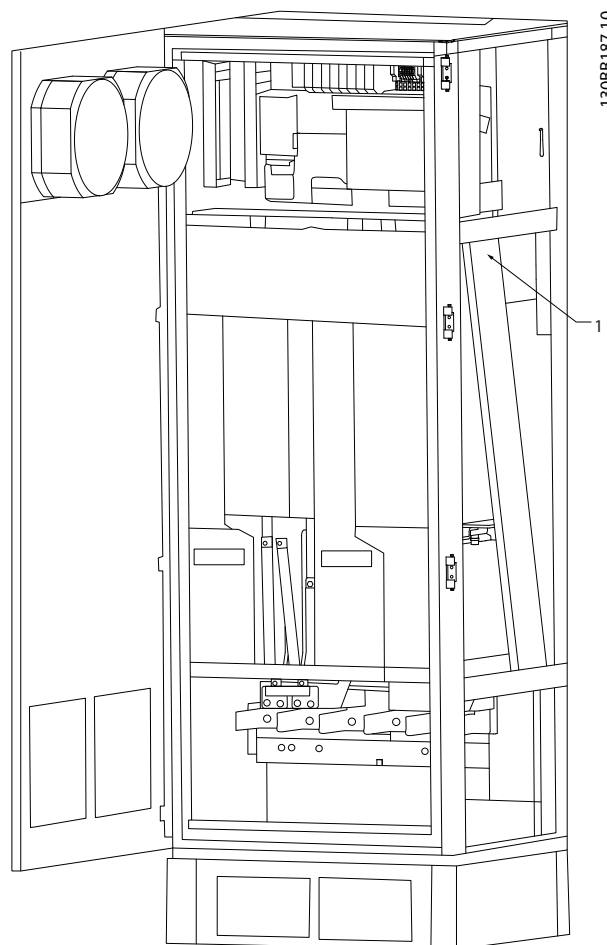

Illustration 4.8 Control Card Wiring Path for Frame Size E9



1 Routing path for the control card wiring, inside the frequency converter enclosure.

Illustration 4.9 Control Card Wiring Path for Frame Size F18

4.8.2 Access to Control Terminals

All terminals for the control cables are located beneath the LCP (both filter and frequency converter LCPs). They are accessed by opening the door of the unit.

4.8.3 Electrical Installation, Control Terminals

To connect the cable to the terminal:

1. Strip insulation by about 9–10 mm

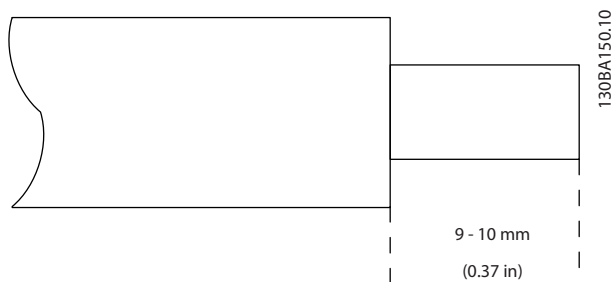

Illustration 4.10 Length to Strip the Insulation

2. Insert a screwdriver (max. 0.4x2.5 mm) in the square hole.
3. Insert the cable in the adjacent circular hole.

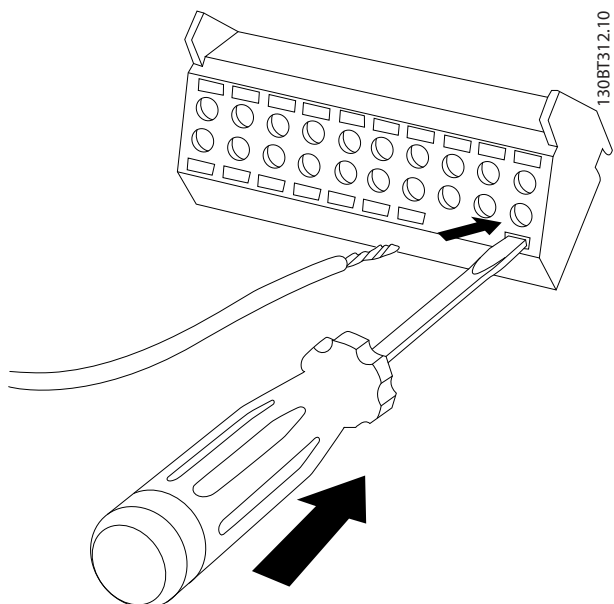

Illustration 4.11 Inserting the Cable in the Terminal Block

4. Remove the screwdriver. The cable is now mounted in the terminal.

To remove the cable from the terminal:

1. Insert a screwdriver (max. 0.4 x 2.5 mm) in the square hole.

2. Pull out the cable.

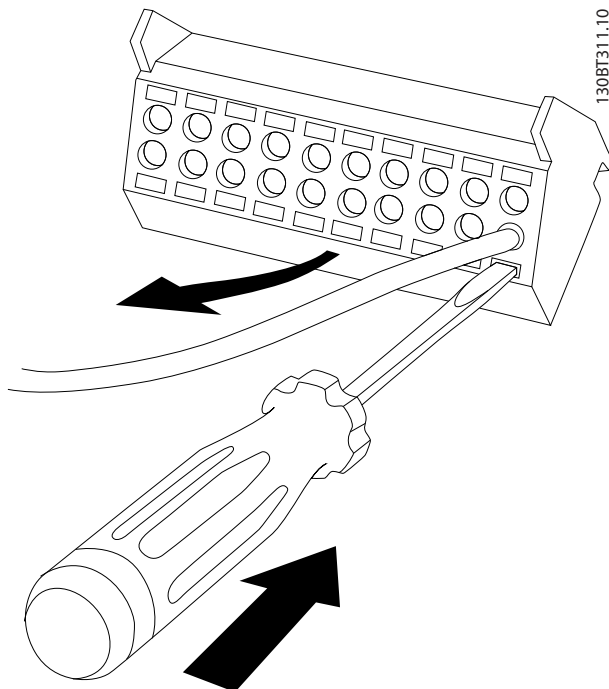

Illustration 4.12 Removing the Screwdriver after Cable Insertion

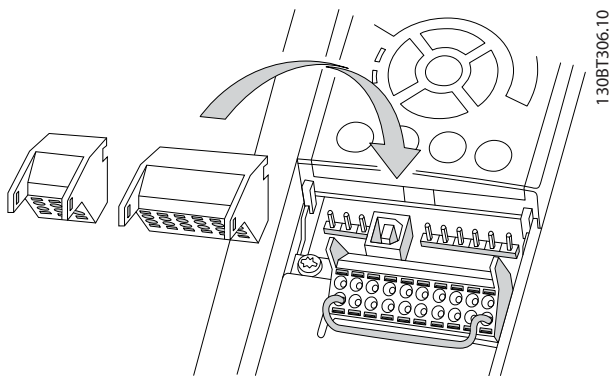

Illustration 4.13 Control Terminal Locations

4.8.4 Electrical Installation, Control Cables

130BC642.10

4

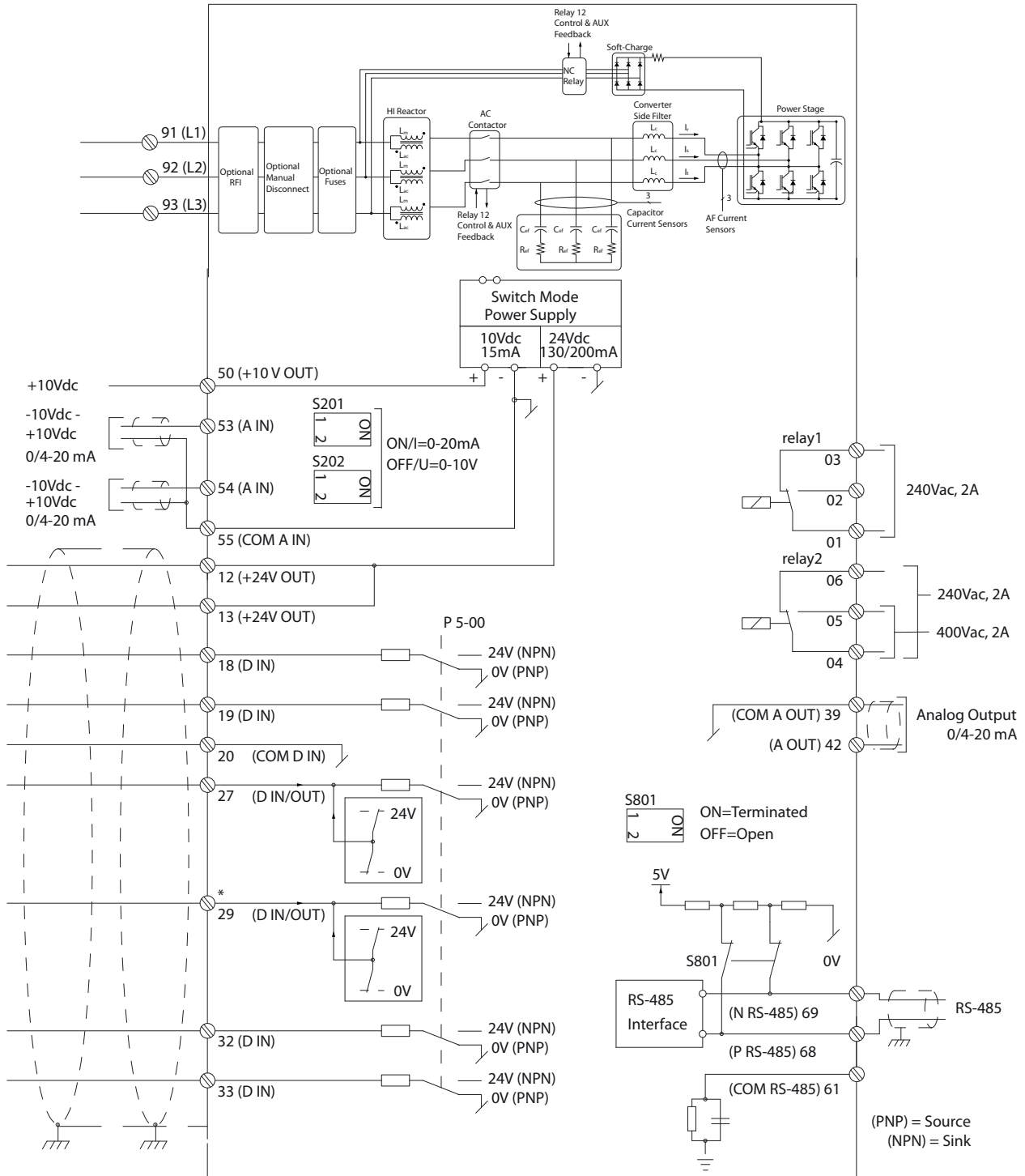

Illustration 4.14 Terminal Diagram

4.9 Additional Connections

4.9.1 Mechanical Brake Control

In hoisting/lowering applications, it is necessary to be able to control an electro-mechanical brake:

- Control the brake using any relay output or digital output (terminal 27 or 29).
- Keep the output closed (voltage-free) as long as the frequency converter is unable to 'support' the motor, due to the load being too heavy, for example.
- Select [32] *Mechanical brake control* in parameter group 5-4* *Relays* for applications with an electro-mechanical brake.
- The brake is released when the motor current exceeds the preset value in 2-20 *Release Brake Current*.
- The brake engages when the output frequency is less than the frequency set in 2-21 *Activate Brake Speed [RPM]* or 2-22 *Activate Brake Speed [Hz]*, only if the frequency converter completes a stop command.

If the frequency converter is in alarm mode or in an overvoltage situation, the mechanical brake immediately cuts in.

4.9.2 Parallel Connection of Motors

The frequency converter can control several parallel-connected motors. The total current consumption of the motors must not exceed the rated output current $I_{M,N}$ for the frequency converter.

NOTICE

Installations with cables connected in a common joint as in *Illustration 4.15*, is only recommended for short cable lengths.

NOTICE

When motors are connected in parallel, 1-29 *Automatic Motor Adaptation (AMA)* cannot be used.

NOTICE

The electronic thermal relay (ETR) of the frequency converter cannot be used as motor protection for the individual motor in systems with parallel-connected motors. Provide further motor protection with thermistors in each motor or individual thermal relays. Circuit breakers are not suitable as protection.

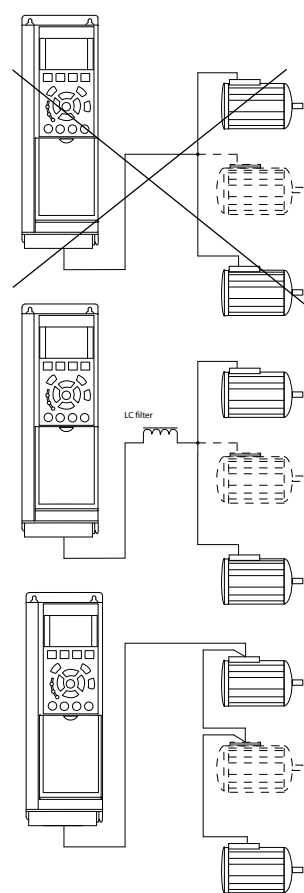

Illustration 4.15 Installations with Cables Connected in a Common Joint

Problems are possible at start and at low RPM values if motor sizes vary widely. The relatively high ohmic resistance in the stator of small motors calls for a higher voltage at start and at low RPM values.

4.9.3 F-frame Options

Space heaters and thermostat

There are space heaters mounted on the cabinet interior of F-frame frequency converters. These heaters are controlled by an automatic thermostat and help control humidity inside the enclosure. The thermostat default settings turn on the heaters at 10 °C (50 °F) and turn them off at 15.6 °C (60 °F).

Cabinet light with power outlet

A light mounted on the cabinet interior of F-frame frequency converters increases visibility during servicing and maintenance. The housing includes a power outlet for temporarily powering tools or other devices, available in 2 voltages:

- 230 V, 50 Hz, 2.5 A, CE/ENEC
- 120 V, 60 Hz, 5 A, UL/cUL

Transformer tap set-up

If the cabinet light and outlet and/or the space heaters and thermostat are installed, transformer T1 requires its taps to be set to the proper input voltage. A 380-480/500 V frequency converter is initially set to the 525 V tap and a 525-690 V frequency converters is set to the 690 V tap to ensure no overvoltage of secondary equipment occurs if the tap is not changed before applying power. See *Table 4.11* to set the proper tap at terminal T1 located in the rectifier cabinet.

Input voltage range [V]	Tap to select [V]
380 V-440	400
441 V-490	460
491 V-550	525
551 V-625	575
626 V-660	660
661 V-690	690

Table 4.11 Transformer Tap Set-up

NAMUR terminals

NAMUR is an international association of automation technology users in the process industries, primarily chemical and pharmaceutical industries in Germany. Selecting this option provides terminals organised and labeled to the specifications of the NAMUR standard for frequency converters input and output terminals. This requires VLT® PTC Thermistor Card MCB 112 VLT® Extended Relay Card MCB 113.

RCD (Residual Current Device)

Uses the core balance method to monitor ground fault currents in grounded and high-resistance grounded systems (TN and TT systems in IEC terminology). There is a pre-warning (50% of main alarm set-point) and a main alarm set-point. Associated with each set-point is an SPDT alarm relay for external use. Requires an external "window-type" current transformer (supplied and installed by the customer).

- Integrated into the frequency converter safe torque off circuit
- IEC 60755 Type B device monitors AC, pulsed DC, and pure DC ground fault currents
- LED bar graph indicator of the ground fault current level from 10–100% of the set-point
- Fault memory
- TEST/RESET button

Insulation Resistance Monitor (IRM)

Monitors the insulation resistance in ungrounded systems (IT systems in IEC terminology) between the system phase conductors and ground. There is an ohmic pre-warning and a main alarm set-point for the insulation level. An SPDT alarm relay for external use is associate with each setpoint.

NOTICE

Only one insulation resistance monitor can be connected to each ungrounded (IT) system.

- Integrated into the frequency converter safe torque off circuit
- LCD display of the ohmic value of the insulation resistance
- Fault memory
- INFO, TEST, and RESET buttons

IEC emergency stop with Pilz safety relay

Includes a redundant 4-wire emergency-stop push button mounted on the front of the enclosure and a Pilz relay that monitors it in conjunction with the frequency converter STO (safet torque off) circuit and the mains contactor located in the options cabinet.

Manual motor starters

Provide 3-phase power for electric blowers often required for larger motors. Power for the starters is provided from the load side of any supplied contactor, circuit breaker, or disconnect switch. Power is fused before each motor starter, and is off when the incoming power to the frequency converters is off. Up to 2 starters are allowed (one if a 30 A, fuse-protected circuit is ordered), and are integrated into the frequency converter STO circuit.

Unit features include:

- Operation switch (on/off)
- Short-circuit and overload protection with test function
- Manual reset function

30 A, fuse-protected terminals

- 3-phase power matching incoming mains voltage for powering auxiliary customer equipment
- Not available if 2 manual motor starters are selected
- Terminals are off when the incoming power to the frequency converter is off
- Power for the fused protected terminals is provided from the load side of any supplied contactor, circuit breaker, or disconnect switch

In applications where the motor is used as a brake, energy is generated in the motor and sent back into the frequency converter. If the energy cannot be transported back to the motor, it increases the voltage in the frequency converter DC line. In applications with frequent braking and/or high inertia loads, this increase may lead to an overvoltage trip in the frequency converter and finally a shut down. Brake resistors are used to dissipate the excess energy resulting from the regenerative braking. The resistor is selected based on its ohmic value, its power dissipation rate and its physical size. Danfoss offers a wide

variety of different resistors that are specifically designed for Danfoss frequency converters.

Load sharing

Load sharing is a feature on standard frequency converters, but is not available on the LHD unit.

4.10 Final Set-up and Test

Before operating the frequency converter, perform a final test of the installation:

1. Locate the motor name plate to find out whether the motor is star- (Y) or delta- connected (Δ).
2. Enter the motor name plate data in the parameter list. Access the list by pressing the [Quick Menu] key and selecting Q2 Quick Set-up. See *Table 4.12*.

1.	Motor Power [kW] or Motor Power [HP]	1-20 Motor Power [kW] 1-21 Motor Power [HP]
2.	Motor Voltage	1-22 Motor Voltage
3.	Motor Frequency	1-23 Motor Frequency
4.	Motor Current	1-24 Motor Current
5.	Motor Nominal Speed	1-25 Motor Nominal Speed

Table 4.12 Quick Set-up Parameters

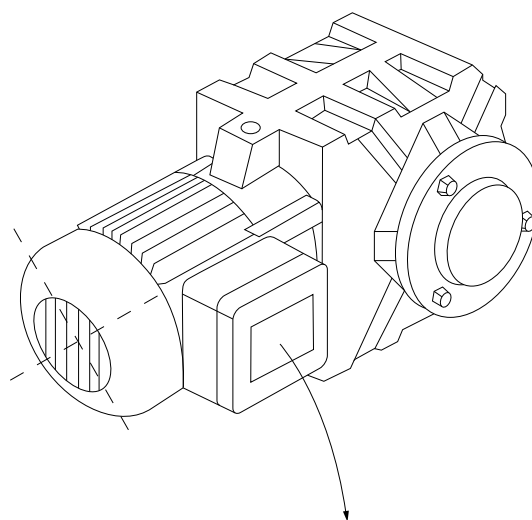

130BT307.10

BAUER D-7 3734 ESLINGEN					
3~ MOTOR NR. 1827421 2003					
S/E005A9					
1,5		KW			
n ₂ 31,5	/min.	400	Y	V	
n ₁ 1400	/min.	50		Hz	
COS θ 0,80		3,6		A	
1,7L					
B	IP 65	H1/1A			

Illustration 4.16 Motor Name Plate

3. Perform an Automatic Motor Adaptation (AMA) to ensure optimum performance.
 - 3a Connect terminal 27 to terminal 12 or set 5-12 Terminal 27 Digital Input to [0] No operation.
 - 3b Activate the AMA 1-29 Automatic Motor Adaptation (AMA).
 - 3c Select either complete or reduced AMA. If an LC filter is mounted, run only the reduced AMA, or remove the LC filter during the AMA procedure.
 - 3d Press [OK]. The display shows "Press [Hand On] to start."
 - 3e Press [Hand On]. A progress bar indicates whether the AMA is in progress.
 - 3f Press [Off] - the frequency converter enters into alarm mode and the display shows that the user terminated AMA.

Stop the AMA during operation

Successful AMA

- The display shows "Press [OK] to finish AMA".
- Press [OK] to exit the AMA state.

Unsuccessful AMA

- The frequency converter enters into alarm mode. A description of the alarm can be found in *chapter 7.5 Troubleshooting*.
- "Report Value" in the alarm log shows the last measuring sequence carried out by the AMA, before the frequency converter entered alarm mode. This number, along with the description of the alarm, helps with troubleshooting. Mention the number and alarm description when contacting Danfoss service personnel.

Unsuccessful AMA is the result of incorrectly registered motor name plate data or too large a difference between the motor power size and the frequency converter power size.

Set up the desired limits for speed and ramp time

Minimum Reference	3-02 <i>Minimum Reference</i>
Maximum Reference	3-03 <i>Maximum Reference</i>

Table 4.13 Reference Parameters

Motor Speed Low Limit	4-11 <i>Motor Speed Low Limit [RPM]</i> or 4-12 <i>Motor Speed Low Limit [Hz]</i>
Motor Speed High Limit	4-13 <i>Motor Speed High Limit [RPM]</i> or 4-14 <i>Motor Speed High Limit [Hz]</i>

Table 4.14 Speed Limits

Ramp-up Time 1 [s]	3-41 <i>Ramp 1 Ramp Up Time</i>
Ramp-down Time 1 [s]	3-42 <i>Ramp 1 Ramp Down Time</i>

Table 4.15 Ramp Times

5 Commissioning

5.1 Safety Instructions

See *chapter 2 Safety* for general safety instructions.

⚠ WARNING

HIGH VOLTAGE

Frequency converters contain high voltage when connected to AC mains input power. Failure to perform installation, start-up, and maintenance by qualified personnel could result in death or serious injury.

- Installation, start-up, and maintenance must be performed by qualified personnel only.

Before applying power:

1. Close the cover properly.
2. Check that all cable glands are firmly tightened.
3. Ensure that input power to the unit is OFF and locked out. Do not rely on the frequency

⚠ CAUTION

Before applying power to the unit, inspect the entire installation as detailed in *Table 5.1*. Check mark those items when completed.

converter disconnect switches for input power isolation.

4. Verify that there is no voltage on input terminals L1 (91), L2 (92), and L3 (93), phase-to-phase and phase-to-ground.
5. Verify that there is no voltage on output terminals 96 (U), 97 (V), and 98 (W), phase-to-phase and phase-to-ground.
6. Confirm continuity of the motor by measuring Ω values on U-V (96-97), V-W (97-98), and W-U (98-96).
7. Check for proper grounding of the frequency converter as well as the motor.
8. Inspect the frequency converter for loose connections on the terminals.
9. Confirm that the supply voltage matches the voltage of the frequency converter and the motor.

Inspect for	Description	<input checked="" type="checkbox"/>
Auxiliary equipment	<ul style="list-style-type: none"> • Look for auxiliary equipment, switches, disconnects, or input fuses/circuit breakers on the input power side of the frequency converter or output side to the motor. Ensure that they are ready for full speed operation. • Check function and installation of any sensors used for feedback to the frequency converter. • Remove power factor correction caps on motors, if present. 	
Cable routing	<ul style="list-style-type: none"> • Use separate metallic conduits for each of the following: <ul style="list-style-type: none"> - Input power - Motor wiring - Control wiring 	
Control wiring	<ul style="list-style-type: none"> • Check for broken or damaged wires and loose connections. • Check that control wiring is isolated from power and motor wiring for noise immunity. • Check the voltage source of the signals, if necessary. • Use shielded or twisted pair cable. Ensure that the shield is terminated correctly. 	
Cooling clearance	<ul style="list-style-type: none"> • Measure that top and bottom clearance is adequate to ensure proper air flow for cooling. 	
EMC considerations	<ul style="list-style-type: none"> • Check for proper installation regarding electromagnetic compatibility. 	
Environmental considerations	<ul style="list-style-type: none"> • See equipment label for the maximum ambient operating temperature limits. • Humidity levels must be 5–95%, non-condensing. 	
Fusing and circuit breakers	<ul style="list-style-type: none"> • Check for proper fusing or circuit breakers. • Check that all fuses are inserted firmly and in operational condition and that all circuit breakers are in the open position. 	

Inspect for	Description	☑
Grounding	<ul style="list-style-type: none"> • The unit requires a ground wire from its chassis to the building ground. • Check for good ground connections that are tight and free of oxidation. • Grounding to conduit or mounting the back panel to a metal surface is not sufficient. 	
Input and output power wiring	<ul style="list-style-type: none"> • Check for loose connections. • Check that motor and mains are in separate conduit or separated screened cables. 	
Panel interior	<ul style="list-style-type: none"> • Inspect that the unit interior is free of debris and corrosion. 	
Switches	<ul style="list-style-type: none"> • Ensure that all switch and disconnect settings are in the proper positions. 	
Vibration	<ul style="list-style-type: none"> • Check that the unit is mounted solidly or that shock mounts are used, as necessary. • Check for an unusual amount of vibration. 	

Table 5.1 Start-up Checklist

5.2 Applying Power

WARNING

HIGH VOLTAGE!

Frequency converters contain high voltage when connected to AC mains. Installation, start-up and maintenance should be performed by qualified personnel only. Failure to comply could result in death or serious injury.

WARNING

UNINTENDED START!

When the frequency converter is connected to AC mains, the motor may start at any time. The frequency converter, motor, and any driven equipment must be in operational readiness. Failure to comply could result in death, serious injury, equipment, or property damage.

1. Confirm that the input voltage is balanced within 3%. If not, correct input voltage imbalance before proceeding.
2. Ensure that optional equipment wiring, if present, matches the installation application.
3. Ensure that all operator devices are off. Panel doors should be closed or cover mounted.
4. Apply power to the unit. Do not start the frequency converter at this time. For units with a disconnect switch, turn the switch on to apply power.

NOTICE

If the status line at the bottom of the LCP reads **AUTO REMOTE COASTING** or **Alarm 60 External Interlock** is displayed, this indicates that the unit is ready to operate but is missing an input signal on terminal 27.

5.3 Local Control Panel Operation

5.3.1 Local Control Panel

The local control panel (LCP) is the combined display and keypad on the front of the unit.

The LCP has several user functions:

- Start, stop, and control speed when in local control.
- Display operational data, status, warnings and cautions.
- Programme frequency converter functions.
- Manually reset the frequency converter after a fault when auto-reset is inactive.

An optional numeric LCP (NLCP) is also available. The NLCP operates in a manner similar to the LCP. See the product relevant *programming guide* for details on use of the NLCP.

NOTICE

For commissioning via PC, install the MCT 10 Set-up Software. The software is available for download (basic version) or for ordering (advanced version, order number 130B1000). For more information and downloads, see www.danfoss.com/BusinessAreas/DrivesSolutions/Software+MCT10/MCT10+Downloads.htm.

5.3.2 LCP Layout

The LCP is divided into 4 functional groups (see *Illustration 5.1*).

- Display area
- Display menu keys
- Navigation keys and indicator lights (LEDs)
- Operation keys and reset

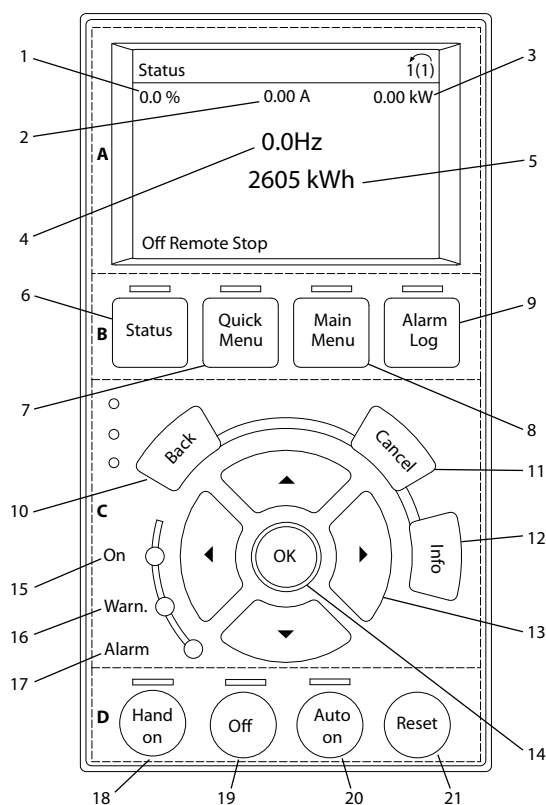

Illustration 5.1 Local Control Panel (LCP)

A. Display Area

The display area is activated when the frequency converter receives power from mains voltage, a DC bus terminal, or an external 24 V DC supply.

The information displayed on the LCP can be customised for user application. Select options in the Quick Menu Q3-13 *Display Settings*.

Callout	Display	Parameter number	Default setting
1	1.1	0-20	Reference %
2	1.2	0-21	Motor current
3	1.3	0-22	Power [kW]
4	2	0-23	Frequency
5	3	0-24	kWh counter

Table 5.2 Legend to *Illustration 5.1, Display Area*

B. Display Menu Keys

Menu keys are used for menu access for parameter set-up, toggling through status display modes during normal operation, and viewing fault log data.

Callout	Key	Function
6	Status	Shows operational information.
7	Quick Menu	Allows access to programming parameters for initial set-up instructions and many detailed application instructions.
8	Main Menu	Allows access to all programming parameters.
9	Alarm Log	Displays a list of current warnings, the last 10 alarms, and the maintenance log.

Table 5.3 Legend to *Illustration 5.1, Display Menu Keys*

C. Navigation Keys and Indicator Lights (LEDs)

Navigation keys are used for programming functions and moving the display cursor. The navigation keys also provide speed control in local (hand) operation. There are also 3 frequency converter status indicator lights in this area.

Callout	Key	Function
10	Back	Reverts to the previous step or list in the menu structure.
11	Cancel	Cancels the last change or command as long as the display mode has not changed.
12	Info	Press for a definition of the function being displayed.
13	Navigation keys	Press to move between items in the menu.
14	OK	Press to access parameter groups or to enable a choice.

Table 5.4 Legend to *Illustration 5.1, Navigation Keys*

Callout	Indicator	Light	Function
15	ON	Green	The ON light activates when the frequency converter receives power from mains voltage, a DC bus terminal, or an external 24 V supply.
16	WARN	Yellow	When a warning is issued, the yellow WARN light comes on and text appears in the display area identifying the problem.
17	ALARM	Red	A fault condition causes the red alarm light to flash and an alarm text is displayed.

Table 5.5 Legend to *Illustration 5.1, Indicator Lights (LEDs)*

D. Operation Keys and Reset

Operation keys are located at the bottom of the LCP.

Callout	Key	Function
18	Hand On	Starts the frequency converter in local control. <ul style="list-style-type: none"> An external stop signal by control input or serial communication overrides the local hand on.
19	Off	Stops the motor but does not remove power to the frequency converter.
20	Auto On	Puts the system in remote operational mode. <ul style="list-style-type: none"> Responds to an external start command by control terminals or serial communication.
21	Reset	Resets the frequency converter manually after a fault has been cleared.

Table 5.6 Legend to *Illustration 5.1, Operation Keys and Reset*

NOTICE

The display contrast can be adjusted by pressing [Status] and [▲]/[▼] keys.

5.3.3 Parameter Settings

Establishing the correct programming for applications often requires setting functions in several related parameters.

Programming data are stored internally in the frequency converter.

- For back-up, upload data into the LCP memory
- To download data to another frequency converter, connect the LCP to that unit and download the stored settings
- Restoring factory default settings does not change data stored in the LCP memory

5.3.4 Uploading/Downloading Data to/from the LCP

1. Press [Off] to stop the motor before uploading or downloading data.
2. Press [Main Menu] *0-50 LCP Copy* and press [OK].
3. Select [*1*] *All to LCP* to upload data to the LCP or select [*2*] *All from LCP* to download data from the LCP.
4. Press [OK]. A progress bar shows the uploading or downloading progress.
5. Press [Hand On] or [Auto On] to return to normal operation.

5.3.5 Changing Parameter Settings

Parameter settings can be accessed and changed from the Quick Menu or from the Main Menu. The Quick Menu only gives access to a limited number of parameters.

1. Press [Quick Menu] or [Main Menu] on the LCP.
2. Press [▲] [▼] to browse through the parameter groups, press [OK] to select a parameter group.
3. Press [▲] [▼] to browse through the parameters, press [OK] to select a parameter.
4. Press [▲] [▼] to change the value of a parameter setting.
5. Press [◀] [▶] to shift digit when a decimal parameter is in the editing state.
6. Press [OK] to accept the change.
7. Press either [Back] twice to enter Status, or press [Main Menu] once to enter the Main Menu.

View changes

Quick Menu Q5 - Changes Made lists all parameters changed from default settings.

- The list only shows parameters, which have been changed in the current edit set-up.
- Parameters, which have been reset to default values, are not listed.
- The message *Empty* indicates that no parameters have been changed.

5.3.6 Restoring Default Settings

NOTICE

Risk of losing programming, motor data, localisation, and monitoring records by restoration of default settings. To provide a back-up, upload data to the LCP before initialisation.

Restoring the default parameter settings is done by initialisation of the frequency converter. Initialisation is carried out through *14-22 Operation Mode* (recommended) or manually.

- Initialisation using *14-22 Operation Mode* does not reset frequency converter settings, such as operating hours, serial communication selections, personal menu settings, fault log, alarm log, and other monitoring functions.
- Manual initialisation erases all motor, programming, localisation, and monitoring data and restores factory default settings.

Recommended initialisation procedure, via *14-22 Operation Mode*

1. Press [Main Menu] twice to access parameters.
2. Scroll to *14-22 Operation Mode* and press [OK].
3. Scroll to [*2*] *Initialisation* and press [OK].
4. Remove power to the unit and wait for the display to turn off.
5. Apply power to the unit.

Default parameter settings are restored during start-up. This may take slightly longer than normal.

6. Alarm 80 is displayed.
7. Press [Reset] to return to operation mode.

Manual initialisation procedure

1. Remove power to the unit and wait for the display to turn off.
2. Press and hold [Status], [Main Menu], and [OK] at the same time while applying power to the unit (approximately 5 s or until audible click and fan starts).

Factory default parameter settings are restored during start-up. This may take slightly longer than normal.

Manual initialisation does not reset the following frequency converter information:

- *15-00 Operating hours*
- *15-03 Power Up's*
- *15-04 Over Temp's*
- *15-05 Over Volt's*

5.4 Basic Programming

5.4.1 Commissioning with SmartStart

The SmartStart wizard enables fast configuration of basic motor and application parameters.

- SmartStart starts automatically, at first power up or after initialisation of the frequency converter.
- Follow the on-screen instructions to complete the commissioning of the frequency converter. Always reactivate SmartStart by selecting *Quick Menu Q4 - SmartStart*.
- For commissioning without use of the SmartStart wizard, refer to *chapter 5.4.2 Commissioning via [Main Menu]* or the *programming guide*.

NOTICE

5

Motor data is required for the SmartStart set-up. The required data is normally available on the motor nameplate.

5.4.2 Commissioning via [Main Menu]

Recommended parameter settings are intended for start-up and check-out purposes. Application settings may vary.

Enter data with power ON, but before operating the frequency converter.

1. Press [Main Menu] on the LCP.
2. Press the navigation keys to scroll to parameter group 0-** Operation/Display and press [OK].

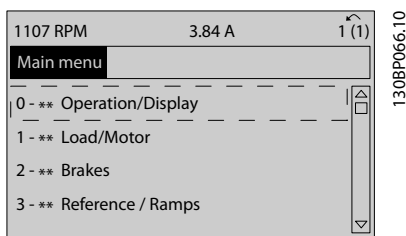

Illustration 5.2 Main Menu

3. Press the navigation keys to scroll to parameter group 0-0* Basic Settings and press [OK].

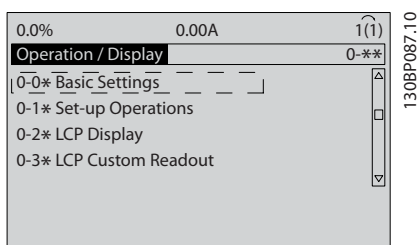

Illustration 5.3 Operation/Display

4. Press the navigation keys to scroll to 0-03 Regional Settings and press [OK].

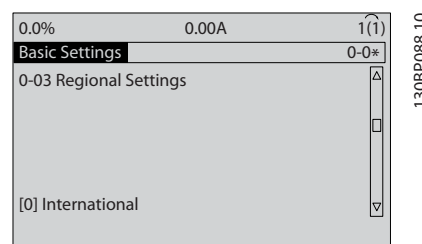

Illustration 5.4 Basic Settings

5. Press the navigation keys to select [0] International or [1] North America as appropriate and press [OK]. (This changes the default settings for a number of basic parameters).
6. Press [Main Menu] on the LCP.
7. Press the navigation keys to scroll to 0-01 Language.
8. Select the language and press [OK].
9. If a jumper wire is in place between control terminals 12 and 27, leave 5-12 Terminal 27 Digital Input at factory default. Otherwise, select No Operation in 5-12 Terminal 27 Digital Input.
10. Make the application specific settings in the following parameters:
 - 10a 3-02 Minimum Reference
 - 10b 3-03 Maximum Reference
 - 10c 3-41 Ramp 1 Ramp Up Time
 - 10d 3-42 Ramp 1 Ramp Down Time
 - 10e 3-13 Reference Site. Linked to Hand/Auto Local Remote.

5.4.3 Asynchronous Motor Set-up

Enter the following motor data. The information can be found on the motor nameplate.

1. 1-20 Motor Power [kW] or 1-21 Motor Power [HP]
2. 1-22 Motor Voltage
3. 1-23 Motor Frequency
4. 1-24 Motor Current
5. 1-25 Motor Nominal Speed

When running in Flux mode, or for optimum performance in VVC+ mode, extra motor data is required to set up the following parameters. The data can be found in the motor data sheet (this data is typically not available on the motor name plate). Run a complete AMA using 1-29 Automatic Motor Adaptation (AMA) [1] Enable Complete AMA or enter the parameters manually. 1-36 Iron Loss Resistance (Rfe) is always entered manually.

1. 1-30 Stator Resistance (R_s)
2. 1-31 Rotor Resistance (R_r)
3. 1-33 Stator Leakage Reactance (X_1)
4. 1-34 Rotor Leakage Reactance (X_2)
5. 1-35 Main Reactance (X_h)
6. 1-36 Iron Loss Resistance (R_{fe})

Application-specific adjustment when running VVC⁺

VVC⁺ is the most robust control mode. In most situations, it provides optimum performance without further adjustments. Run a complete AMA for best performance.

Application-specific adjustment when running Flux

Flux mode is the preferred control mode for optimum shaft performance in dynamic applications. Perform an AMA since this control mode requires precise motor data. Depending on the application, further adjustments may be required.

See Table 5.7 for application-related recommendations.

Application	Settings
Low-inertia applications	Keep calculated values.
High-inertia applications	1-66 Min. Current at Low Speed. Increase current to a value between default and maximum depending on the application. Set ramp times matching the application. Too fast ramp up causes an overcurrent or overtorque. Too fast ramp down causes an overvoltage trip.
High load at low speed	1-66 Min. Current at Low Speed. Increase current to a value between default and maximum depending on the application.
No-load application	Adjust 1-18 Min. Current at No Load to achieve smoother motor operation by reducing torque ripple and vibration.
Flux sensorless only	Adjust 1-53 Model Shift Frequency. Example 1: If the motor oscillates at 5 Hz and dynamics performance is required at 15 Hz, set 1-53 Model Shift Frequency to 10 Hz. Example 2: If the application involves dynamic load changes at low speed, reduce 1-53 Model Shift Frequency. Observe the motor behaviour to make sure that the model shift frequency is not reduced too much. Symptoms of inappropriate model shift frequency are motor oscillations or frequency converter tripping.

Table 5.7 Recommendations for Flux Applications

5.4.4 Permanent Magnet Motor Set-up

NOTICE

Only use permanent magnet (PM) motor with fans and pumps.

Initial Programming Steps

1. Activate PM motor operation 1-10 Motor Construction, select (1) PM, non salient SPM
2. Set 0-02 Motor Speed Unit to [0] RPM

Programming motor data

After selecting PM motor in 1-10 Motor Construction, the PM motor-related parameters in parameter groups 1-2* Motor Data, 1-3* Adv. Motor Data and 1-4* are active. The necessary data can be found on the motor nameplate and in the motor data sheet.

Program the following parameters in the listed order

1. 1-24 Motor Current
2. 1-26 Motor Cont. Rated Torque
3. 1-25 Motor Nominal Speed
4. 1-39 Motor Poles
5. 1-30 Stator Resistance (R_s)
Enter line to common stator winding resistance (R_s). If only line-line data are available, divide the line-line value with 2 to achieve the line to common (starpoint) value.
It is also possible to measure the value with an ohmmeter, which takes the resistance of the cable into account. Divide the measured value by 2 and enter the result.
6. 1-37 d-axis Inductance (L_d)
Enter line to common direct axis inductance of the PM motor.
If only line-line data are available, divide the line-line value with 2 to achieve the line-common (starpoint) value.
It is also possible to measure the value with an inductancemeter, which takes the inductance of the cable into account. Divide the measured value by 2 and enter the result.
7. 1-40 Back EMF at 1000 RPM
Enter line to line back EMF of PM Motor at 1000 RPM mechanical speed (RMS value). Back EMF is the voltage generated by a PM motor when no drive is connected and the shaft is turned externally. Back EMF is normally specified for nominal motor speed or for 1000 RPM measured between 2 lines. If the value is not available for a motor speed of 1000 RPM, calculate the correct value as follows: If back EMF is e.g. 320 V at 1800 RPM, it can be calculated at 1000 RPM as follows:

Back EMF = (Voltage / RPM)*1000 = (320/1800)*1000 = 178. This is the value that must be programmed for *1-40 Back EMF at 1000 RPM*.

Test motor operation

1. Start the motor at low speed (100 to 200 RPM). If the motor does not turn, check installation, general programming and motor data.
2. Check if start function in *1-70 PM Start Mode* fits the application requirements.

Rotor detection

This function is the recommended choice for applications where the motor starts from standstill, e.g. pumps or conveyors. On some motors, an acoustic sound is heard when the impulse is sent out. This does not harm the motor.

Parking

This function is the recommended choice for applications where the motor is rotating at slow speed eg. windmilling in fan applications. *2-06 Parking Current* and *2-07 Parking Time* can be adjusted. Increase the factory setting of these parameters for applications with high inertia.

Start the motor at nominal speed. If the application does not run well, check the VVC+ PM settings. Recommendations in different applications can be seen in *Table 5.7*.

Application	Settings
Low inertia applications $I_{Load}/I_{Motor} < 5$	<i>1-17 Voltage filter time const.</i> to be increased by factor 5 to 10 <i>1-14 Damping Gain</i> should be reduced <i>1-66 Min. Current at Low Speed</i> should be reduced (<100%)
Low inertia applications $50 > I_{Load}/I_{Motor} > 5$	Keep calculated values
High inertia applications $I_{Load}/I_{Motor} > 50$	<i>1-14 Damping Gain</i> , <i>1-15 Low Speed Filter Time Const.</i> and <i>1-16 High Speed Filter Time Const.</i> should be increased
High load at low speed <30% (rated speed)	<i>1-17 Voltage filter time const.</i> should be increased <i>1-66 Min. Current at Low Speed</i> should be increased (>100% for a prolonged time can overheat the motor)

Table 5.8 Recommendations in Different Applications

If the motor starts oscillating at a certain speed, increase *1-14 Damping Gain*. Increase the value in small steps. Depending on the motor, a good value for this parameter can be 10% or 100% higher than the default value.

Starting torque can be adjusted in *1-66 Min. Current at Low Speed*. 100% provides nominal torque as starting torque.

5.4.5 Automatic Energy Optimisation (AEO)

NOTICE

AEO is not relevant for permanent magnet motors.

AEO is a procedure which minimises voltage to the motor, thereby reducing energy consumption, heat, and noise.

To activate AEO, set parameter *1-03 Torque Characteristics* to *[2] Auto Energy Optim. CT* or *[3] Auto Energy Optim. VT*.

5.4.6 Automatic Motor Adaptation (AMA)

AMA is a procedure which optimises compatibility between the frequency converter and the motor.

- The frequency converter builds a mathematical model of the motor for regulating output motor current. The procedure also tests the input phase balance of electrical power. It compares the motor characteristics with the entered nameplate data.
- The motor shaft does not turn and no harm is done to the motor while running the AMA.
- Some motors may be unable to run the complete version of the test. In that case, select *[2] Enable reduced AMA*.
- If an output filter is connected to the motor, select *[2] Enable reduced AMA*.
- If warnings or alarms occur, see *chapter 7 Diagnostics and Troubleshooting*.
- Run this procedure on a cold motor for best results.

To run AMA

1. Press [Main Menu] to access parameters.
2. Scroll to parameter group *1-** Load and Motor* and press [OK].
3. Scroll to parameter group *1-2* Motor Data* and press [OK].
4. Scroll to *1-29 Automatic Motor Adaptation (AMA)* and press [OK].
5. Select *[1] Enable complete AMA* and press [OK].
6. Follow the on-screen instructions.
7. The test runs automatically and indicates when it is complete.
8. The advanced motor data is entered in parameter group *1-3* Adv. Motor Data*.

5.5 Checking Motor Rotation

If warnings or alarms occur, see *chapter 7.3 Warnings and Alarm Definitions - Frequency Converter* or .

NOTICE

Risk of damage to pumps/compressors caused by motor running in wrong direction. Before running the frequency converter, check the motor rotation.

The motor runs briefly at 5 Hz or the minimum frequency set in parameter *4-12 Motor Speed Low Limit [Hz]*.

1. Press [Main Menu].
2. Scroll to parameter *1-28 Motor Rotation Check* and press [OK].
3. Scroll to *[1] Enable*.

The following text appears: *Note! Motor may run in wrong direction*.

4. Press [OK].
5. Follow the on-screen instructions.

NOTICE

To change the direction of rotation, remove power to the frequency converter and wait for power to discharge. Reverse the connection of any 2 of the 3 motor wires on the motor or frequency converter side of the connection.

5.6 Local-control Test

1. Press [Hand On] to provide a local start command to the frequency converter.
2. Accelerate the frequency converter by pressing [▲] to full speed. Moving the cursor left of the decimal point provides quicker input changes.
3. Note any acceleration problems.
4. Press [Off]. Note any deceleration problems.

In the event of acceleration or deceleration problems, see *chapter 7.5 Troubleshooting*. See for resetting the frequency converter after a trip.

5.7 System Start-up

The procedure in this section requires user-wiring and application programming to be completed. The following procedure is recommended after application set-up is completed.

1. Press [Auto On].
2. Apply an external run command.
3. Adjust the speed reference throughout the speed range.
4. Remove the external run command.
5. Check the sound and vibration levels of the motor to ensure that the system is working as intended.

6 Application Examples

6.1 Introduction

The sections in this chapter describe how to configure the communication between *Safety Option MCB152* and Siemens devices.

6.2 Application Examples

6.2.1 Speed

6

		Parameters	
FC		Function	Setting
+24 V	12	6-10 Terminal 53	0.07 V*
+24 V	13	Low Voltage	
D IN	18	6-11 Terminal 53	10 V*
D IN	19	High Voltage	
COM	20	6-14 Terminal 53	0 Hz
D IN	27	Low Ref./Feedb. Value	
D IN	29	6-15 Terminal 53	50 Hz
D IN	32	High Ref./Feedb. Value	
D IN	33		
D IN	37		
* = Default Value			
Notes/comments: D IN 37 is an option.			

Table 6.1 Analog Speed Reference (Voltage)

		Parameters	
FC		Function	Setting
+24 V	12	6-12 Terminal 53	4 mA*
+24 V	13	Low Current	
D IN	18	6-13 Terminal 53	20 mA*
D IN	19	High Current	
COM	20	6-14 Terminal 53	0 Hz
D IN	27	Low Ref./Feedb. Value	
D IN	29	6-15 Terminal 53	50 Hz
D IN	32	High Ref./Feedb. Value	
D IN	33		
D IN	37		
* = Default Value			
Notes/comments: D IN 37 is an option.			

Table 6.2 Analog Speed Reference (Current)

		Parameters	
FC		Function	Setting
+24 V	12	6-10 Terminal 53	0.07 V*
+24 V	13	Low Voltage	
D IN	18	6-11 Terminal 53	10 V*
D IN	19	High Voltage	
COM	20	6-14 Terminal 53	0 Hz
D IN	27	Low Ref./Feedb. Value	
D IN	29	6-15 Terminal 53	1500 Hz
D IN	32	High Ref./Feedb. Value	
D IN	33		
D IN	37		
* = Default Value			
Notes/comments: D IN 37 is an option.			

Table 6.3 Speed Reference (Using a Manual Potentiometer)

		Parameters	
FC		Function	Setting
+24 V	12	5-10 Terminal 18	[8] Start*
+24 V	13	Digital Input	
D IN	18	5-12 Terminal 27	[19] Freeze Reference
D IN	19	Digital Input	
COM	20	5-13 Terminal 29	[21] Speed Up
D IN	27	Digital Input	
D IN	29	5-14 Terminal 32	[22] Speed Down
D IN	32	Digital Input	
D IN	33		
D IN	37		
* = Default Value			
Notes/comments: D IN 37 is an option.			

Table 6.4 Speed Up/Down

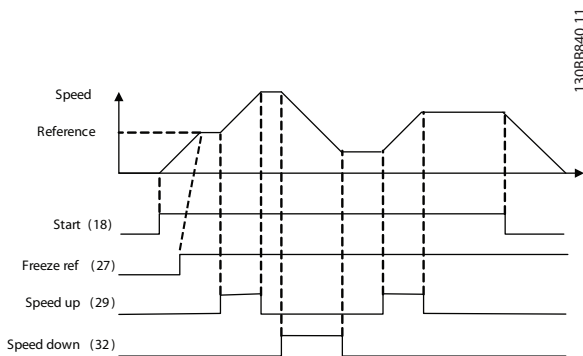

Illustration 6.1 Speed Up/Down

6.2.2 Start/Stop

		Parameters	
FC		Function	Setting
+24 V	12	5-10 Terminal 18	[8] Start*
+24 V	13	Digital Input	
D IN	18	5-12 Terminal 27	[0] No operation
D IN	19	Digital Input	
COM	20	5-19 Terminal 37	[1] Safe Stop Alarm
D IN	27	Safe Stop	
D IN	29		
D IN	32		
D IN	33		
D IN	37		
* = Default Value			
Notes/comments: If 5-12 Terminal 27 Digital Input is set to [0] No operation, a jumper wire to terminal 27 is not needed. D IN 37 is an option.			

Table 6.5 Start/Stop Command with Safe Stop Option

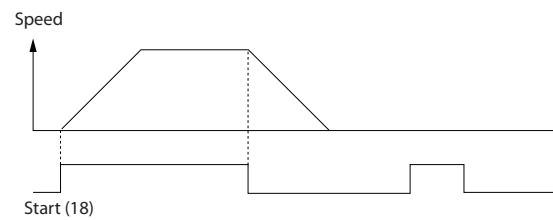

Illustration 6.2 Start/Stop Command with Safe Stop

6

FC		Parameters	
		Function	Setting
+24 V	12	5-10 Terminal 18	[9] Latched Start
+24 V	13	Digital Input	Start
D IN	18	5-12 Terminal 27	[6] Stop Inverse
D IN	19	Digital Input	Inverse
COM	20	* = Default Value	
D IN	27	Notes/comments:	
D IN	29	If 5-12 Terminal 27 Digital Input is set to [0] No operation, a jumper wire to terminal 27 is not needed.	
D IN	32	D IN 37 is an option.	
D IN	33		
D IN	37		
+10 V	50		
A IN	53		
A IN	54		
COM	55		
A OUT	42		
COM	39		

Table 6.6 Pulse Start/Stop

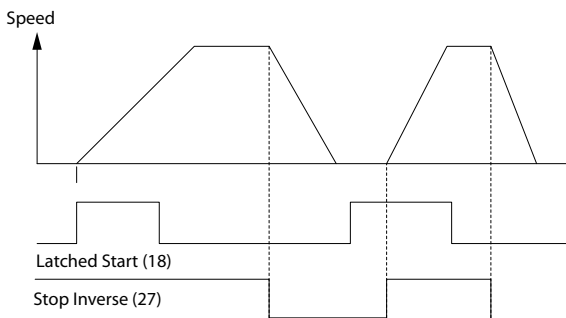

Illustration 6.3 Latched Start/Stop Inverse

FC		Parameters	
		Function	Setting
+24 V	12	5-10 Terminal 18	[8] Start
+24 V	13	Digital Input	Start
D IN	18	5-11 Terminal 19	[10] Reversing*
D IN	19	Digital Input	
COM	20		
D IN	27	5-12 Terminal 27	[0] No operation
D IN	29	Digital Input	
D IN	32	5-14 Terminal 32	[16] Preset ref bit 0
D IN	33	Digital Input	
D IN	37	5-15 Terminal 33	[17] Preset ref bit 1
+10 V	50	3-10 Preset Reference	
A IN	53	Preset ref. 0	25%
A IN	54	Preset ref. 1	50%
COM	55	Preset ref. 2	75%
A OUT	42	Preset ref. 3	100%
COM	39	* = Default Value	
		Notes/comments:	
		D IN 37 is an option.	

Table 6.7 Start/Stop with Reversing and 4 Preset Speeds

6.2.3 External Alarm Reset

FC		Parameters	
		Function	Setting
+24 V	12	5-11 Terminal 19	[1] Reset
+24 V	13	Digital Input	
D IN	18	* = Default Value	
D IN	19	Notes/comments:	
COM	20	D IN 37 is an option.	
D IN	27		
D IN	29		
D IN	32		
D IN	33		
D IN	37		
+10 V	50		
A IN	53		
A IN	54		
COM	55		
A OUT	42		
COM	39		

Table 6.8 External Alarm Reset

6.2.4 RS-485

		Parameters	
FC		Function	Setting
+24 V	12	8-30 Protocol	FC*
+24 V	13	8-31 Address	1*
D IN	18	8-32 Baud Rate	9600*
D IN	19	* = Default Value	
COM	20	Notes/comments:	
D IN	27	Select protocol, address and baud rate in the above mentioned parameters.	
D IN	29	D IN 37 is an option.	
D IN	32		
D IN	33		
D IN	37		
+10 V	50		
A IN	53		
A IN	54		
COM	55		
A OUT	42		
COM	39		

Table 6.9 RS-485 Network Connection

6.2.5 Motor Thermistor

WARNING

THERMISTOR INSULATION

Risk of personal injury or equipment damage.

- Use only thermistors with reinforced or double insulation to meet PELV insulation requirements.

		Parameters	
VLT		Function	Setting
+24 V	12	1-90 Motor Thermal Protection	[2] Thermistor trip
+24 V	13	1-93 Thermistor Source	[1] Analog input 53
D IN	18	* = Default Value	
D IN	19	Notes/comments:	
COM	20	If only a warning is desired, parameter 1-90 Motor Thermal Protection should be set to [1] Thermistor warning.	
D IN	27	D IN 37 is an option.	
D IN	29		
D IN	32		
D IN	33		
D IN	37		
+10 V	50		
A IN	53		
A IN	54		
COM	55		
A OUT	42		
COM	39		

Table 6.10 Motor Thermistor

7 Diagnostics and Troubleshooting

7.1 Status Messages

When the frequency converter is in *Status mode*, status messages are generated automatically and appear in the bottom line of the display (see *Illustration 7.1*).

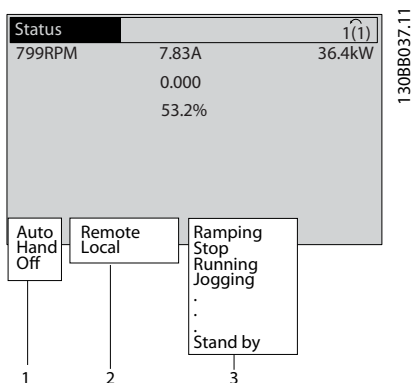

1	Operation mode (see <i>Table 7.1</i>)
2	Reference site (see <i>Table 7.2</i>)
3	Operation status (see <i>Table 7.3</i>)

Illustration 7.1 Status Display

Table 7.1 to Table 7.3 describe the displayed status messages.

Off	The frequency converter does not react to any control signal until [Auto On] or [Hand On] is pressed.
Auto On	The frequency converter is controlled from the control terminals and/or the serial communication.
Hand On	Control the unit via the navigation keys on the LCP. Stop commands, reset, reversing, DC brake, and other signals applied to the control terminals can override local control.

Table 7.1 Operation Mode

Remote	The speed reference is given from external signals, serial communication, or internal preset references.
Local	The frequency converter uses [Hand On] control or reference values from the LCP.

Table 7.2 Reference Site

AC Brake	AC Brake was selected in <i>2-10 Brake Function</i> . The AC brake over-magnetises the motor to achieve a controlled slow down.
AMA finish OK	Automatic motor adaptation (AMA) was carried out successfully.
AMA ready	AMA is ready to start. Press [Hand On] to start.
AMA running	AMA process is in progress.
Braking	The brake chopper is in operation. The brake resistor absorbs generative energy.
Braking max.	The brake chopper is in operation. The power limit for the brake resistor has been reached.
Coast	<ul style="list-style-type: none"> Coast inverse was selected as a function for a digital input (parameter group 5-1* <i>Digital Inputs</i>). The corresponding terminal is not connected. Coast activated by serial communication
Ctrl. Ramp-down	Control Ramp-down was selected in <i>14-10 Mains Failure</i> . <ul style="list-style-type: none"> The mains voltage is below the value set in <i>14-11 Mains Voltage at Mains Fault</i> at mains fault The frequency converter ramps down the motor using a controlled ramp down
Current High	The frequency converter output current is above the limit set in <i>4-51 Warning Current High</i> .
Current Low	The frequency converter output current is below the limit set in <i>4-52 Warning Speed Low</i>
DC Hold	DC hold is selected in <i>1-80 Function at Stop</i> and a stop command is active. The motor is held by a DC current set in <i>2-00 DC Hold/Preheat Current</i> .
DC Stop	The motor is held with a DC current (<i>2-01 DC Brake Current</i>) for a specified time (<i>2-02 DC Braking Time</i>). <ul style="list-style-type: none"> DC brake is activated in <i>2-03 DC Brake Cut In Speed [RPM]</i> and a stop command is active. DC brake (inverse) is selected as a function for a digital input (parameter group 5-1* <i>Digital Inputs</i>). The corresponding terminal is not active. The DC brake is activated via serial communication.
Feedback high	The sum of all active feedbacks is above the feedback limit set in <i>4-57 Warning Feedback High</i> .
Feedback low	The sum of all active feedbacks is below the feedback limit set in <i>4-56 Warning Feedback Low</i> .

Freeze output	<p>The remote reference is active, which holds the present speed.</p> <ul style="list-style-type: none"> Freeze output was selected as a function for a digital input (parameter group 5-1* <i>Digital Inputs</i>). The corresponding terminal is active. Speed control is only possible via the terminal functions Speed Up and Speed Down. Hold ramp is activated via serial communication.
Freeze output request	A freeze output command has been given, but the motor remains stopped until a run permissive signal is received.
Freeze ref.	<i>Freeze Reference</i> was selected as a function for a digital input (parameter group 5-1* <i>Digital Inputs</i>). The corresponding terminal is active. The frequency converter saves the actual reference. Changing the reference is now only possible via terminal functions speed up and speed down.
Jog request	A jog command has been given, but the motor remains stopped until a run permissive signal is received via a digital input.
Jogging	<p>The motor is running as programmed in 3-19 <i>Jog Speed [RPM]</i>.</p> <ul style="list-style-type: none"> <i>Jog</i> was selected as function for a digital input (parameter group 5-1* <i>Digital Inputs</i>). The corresponding terminal is active. The jog function is activated via the serial communication. The jog function was selected as a reaction for a monitoring function. The monitoring function is active.
Motor check	In 1-80 <i>Function at Stop, Motor Check</i> was selected. A stop command is active. To ensure that a motor is connected to the frequency converter, a permanent test current is applied to the motor.
OVC control	<i>Overvoltage</i> control was activated in 2-17 <i>Overvoltage Control, [2] Enabled</i> . The connected motor supplies the frequency converter with generative energy. The overvoltage control adjusts the V/Hz ratio to run the motor in controlled mode and to prevent the frequency converter from tripping.
Power Unit Off	<p>(Only frequency converters with an 24 V external supply installed).</p> <p>Mains supply to the frequency converter is removed, but the control card is supplied by the external 24 V.</p>

Protection md	<p>Protection mode is active. The unit has detected a critical status (an overcurrent or overvoltage).</p> <ul style="list-style-type: none"> To avoid tripping, the switching frequency is reduced to 4 kHz. If possible, protection mode ends after approximately 10 s. Protection mode can be restricted in 14-26 <i>Trip Delay at Inverter Fault</i>.
QStop	<p>The motor is decelerating using 3-81 <i>Quick Stop Ramp Time</i>.</p> <ul style="list-style-type: none"> <i>Quick stop inverse</i> was selected as a function for a digital input (parameter group 5-1* <i>Digital Inputs</i>). The corresponding terminal is not active. The quick stop function was activated via serial communication.
Ramping	The motor is accelerating/decelerating using the active ramp up/down. The reference, a limit value, or a standstill is not yet reached.
Ref. high	The sum of all active references is above the reference limit set in 4-55 <i>Warning Reference High</i> .
Ref. low	The sum of all active references is below the reference limit set in 4-54 <i>Warning Reference Low</i> .
Run on ref.	The frequency converter is running in the reference range. The feedback value matches the setpoint value.
Run request	A start command has been given, but the motor is stopped until a run permissive signal is received via digital input.
Running	The frequency converter drives the motor.
Sleep Mode	The energy saving function is enabled. The motor has stopped, but restarts automatically when required.
Speed high	Motor speed is above the value set in 4-53 <i>Warning Speed High</i> .
Speed low	Motor speed is below the value set in 4-52 <i>Warning Speed Low</i> .
Standby	In Auto On mode, the frequency converter starts the motor with a start signal from a digital input or serial communication.
Start delay	In 1-71 <i>Start Delay</i> , a delay starting time was set. A start command is activated and the motor starts after the start delay time expires.
Start fwd/rev	Start forward and start reverse were selected as functions for 2 different digital inputs (parameter group 5-1* <i>Digital Inputs</i>). The motor starts in forward or reverse depending on which corresponding terminal is activated.
Stop	The frequency converter has received a stop command from the LCP, digital input, or serial communication.

Trip	An alarm occurred and the motor is stopped. Once the cause of the alarm is cleared, the frequency converter can be reset manually by pressing [Reset] or remotely by control terminals or serial communication.
Trip lock	An alarm occurred and the motor is stopped. Once the cause of the alarm is cleared, power must be cycled to the frequency converter. The frequency converter can then be reset manually by pressing [Reset] or remotely by control terminals or serial communication.

Table 7.3 Operation Status

NOTICE

In auto/remote mode, the frequency converter requires external commands to execute functions.

7

7.2 Warning and Alarm Types

The frequency converter monitors the condition of its input power, output, and motor factors as well as other system performance indicators. A warning or alarm does not necessarily indicate a problem internal to the frequency converter itself. In many cases, it indicates failure conditions from:

- input voltage
- motor load
- motor temperature
- external signals
- other areas monitored by internal logic

Investigate as indicated in the alarm or warning.

7.2.1 Warnings

A warning is issued when an alarm condition is impending or when an abnormal operating condition is present and may result in the frequency converter issuing an alarm. A warning clears by itself when the abnormal condition is removed.

7.2.2 Alarm Trip

An alarm is issued when the frequency converter is tripped, that is, the frequency converter suspends operation to prevent frequency converter or system damage. The motor coasts to a stop. The frequency converter logic continues to operate and monitors the frequency converter status. After the fault condition is remedied, reset the frequency converter. It is then ready to start operation again.

A trip can be reset in any of 4 ways:

- Press [Reset] on the LCP
- Digital reset input command
- Serial communication reset input command
- Auto reset

7.2.3 Alarm Trip-lock

An alarm that causes the frequency converter to trip-lock requires that input power is cycled. The motor coasts to a stop. The frequency converter logic continues to operate and monitors the frequency converter status. Remove input power to the frequency converter and correct the cause of the fault, then restore power. This action puts the frequency converter into a trip condition as described in chapter 7.2.2 Alarm Trip and may be reset in any of the 4 ways.

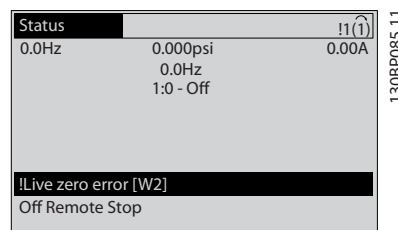

Illustration 7.2 Warning Display

An alarm or trip-lock alarm flashes in the display along with the alarm number.

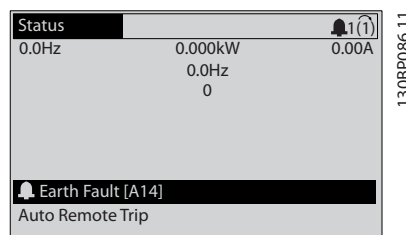
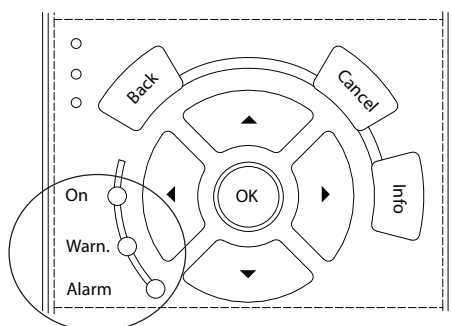

Illustration 7.3 Alarm Display

In addition to the text and alarm code in the display, there are 3 status indicator lights.



130BB467.1.1

Illustration 7.4 Status Indicator Lights

	Warning LED	Alarm LED
Warning	On	Off
Alarm	Off	On (Flashing)
Trip-Lock	On	On (Flashing)

Table 7.4 Status Indicator Lights Explanations

7.3 Warnings and Alarm Definitions - Frequency Converter

The following warning/alarm information defines each warning/alarm condition, provides the probable cause for the condition, and details a remedy or troubleshooting procedure.

WARNING 1, 10 Volts low

The control card voltage is <10 V from terminal 50. Remove some of the load from terminal 50, as the 10 V supply is overloaded. Maximum 15 mA or minimum 590 Ω.

A short-circuit in a connected potentiometer or incorrect wiring of the potentiometer can cause this condition.

Troubleshooting

- Remove the wiring from terminal 50. If the warning clears, the problem is with the wiring. If the warning does not clear, replace the control card.

WARNING/ALARM 2, Live zero error

This warning or alarm only appears if programmed in 6-01 Live Zero Timeout Function. The signal on one of the analog inputs is less than 50% of the minimum value programmed for that input. Broken wiring or a faulty device sending the signal can cause this condition.

Troubleshooting

- Check the connections on all the analog input terminals.
 - Control card terminals 53 and 54 for signals, terminal 55 common.
 - MCB 101 terminals 11 and 12 for signals, terminal 10 common.

- MCB 109 terminals 1, 3, 5 for signals, terminals 2, 4, 6 common.

- Check that the frequency converter programming and switch settings match the analog signal type.
- Perform an input terminal signal test.

WARNING/ALARM 3, No motor

No motor has been connected to the output of the frequency converter.

WARNING/ALARM 4, Mains phase loss

A phase is missing on the supply side, or the mains voltage imbalance is too high. This message also appears for a fault in the input rectifier on the frequency converter. Options are programmed in 14-12 Function at Mains Imbalance.

Troubleshooting

- Check the supply voltage and supply currents to the frequency converter.

WARNING 5, DC link voltage high

The intermediate circuit voltage (DC) is higher than the high-voltage warning limit. The limit is dependent on the frequency converter voltage rating. The unit is still active.

WARNING 6, DC link voltage low

The intermediate circuit voltage (DC) is lower than the low-voltage warning limit. The limit is dependent on the frequency converter voltage rating. The unit is still active.

WARNING/ALARM 7, DC overvoltage

If the intermediate circuit voltage exceeds the limit, the frequency converter trips after a time.

Troubleshooting

- Connect a brake resistor.
- Extend the ramp time.
- Change the ramp type.
- Activate the functions in 2-10 Brake Function.
- Increase 14-26 Trip Delay at Inverter Fault.
- If the alarm/warning occurs during a power sag, use kinetic back-up (14-10 Mains Failure).

WARNING/ALARM 8, DC under voltage

If the DC link voltage drops below the undervoltage limit, the frequency converter checks if a 24 V DC back-up supply is connected. If no 24 V DC back-up supply is connected, the frequency converter trips after a fixed time delay. The time delay varies with unit size.

Troubleshooting

- Check that the supply voltage matches the frequency converter voltage.
- Perform an input voltage test.
- Perform a soft charge circuit test.

WARNING/ALARM 9, Inverter overload

The frequency converter has run with more than 100% overload for too long and is about to cut out. The counter for electronic thermal inverter protection issues a warning at 98% and trips at 100%, while giving an alarm. The frequency converter cannot be reset until the counter is below 90%.

Troubleshooting

- Compare the output current shown on the LCP with the frequency converter rated current.
- Compare the output current shown on the LCP with the measured motor current.
- Display the thermal drive load on the LCP and monitor the value. When running above the frequency converter continuous current rating, the counter increases. When running below the frequency converter continuous current rating, the counter decreases.

WARNING/ALARM 10, Motor overload temperature

According to the electronic thermal protection (ETR), the motor is too hot. Select whether the frequency converter issues a warning or an alarm when the counter reaches 100% in *1-90 Motor Thermal Protection*. The fault occurs when the motor runs with more than 100% overload for too long.

Troubleshooting

- Check for motor overheating.
- Check if the motor is mechanically overloaded.
- Check that the motor current set in *1-24 Motor Current* is correct.
- Ensure that the motor data in *parameters 1-20 to 1-25* are set correctly.
- If an external fan is in use, check that it is selected in *1-91 Motor External Fan*.
- Running AMA in *1-29 Automatic Motor Adaptation (AMA)* tunes the frequency converter to the motor more accurately and reduces thermal loading.

WARNING/ALARM 11, Motor thermistor overtemp

The thermistor may be disconnected. Select whether the frequency converter issues a warning or an alarm in *1-90 Motor Thermal Protection*.

Troubleshooting

- Check for motor overheating.
- Check if the motor is mechanically overloaded.
- Check that the thermistor is connected correctly between either terminal 53 or 54 (analog voltage input) and terminal 50 (+10 V supply). Also check that the terminal switch for 53 or 54 is set for voltage. Check that *1-93 Thermistor Resource* is set to terminal 53 or 54.

- When using digital inputs 18 or 19, check that the thermistor is connected correctly between either terminal 18 or 19 (digital input PNP only) and terminal 50.
- If a KTY sensor is used, check for correct connection between terminals 54 and 55
- If using a thermal switch or thermistor, check that the programming of *1-93 Thermistor Resource* matches sensor wiring.
- If using a KTY Sensor, check the programming of *1-95 KTY Sensor Type*, *1-96 KTY Thermistor Resource* and *1-97 KTY Threshold level* match sensor wiring.

WARNING/ALARM 12, Torque limit

The torque has exceeded the value in *4-16 Torque Limit Motor Mode* or the value in *4-17 Torque Limit Generator Mode*. *14-25 Trip Delay at Torque Limit* can change this warning from a warning-only condition to a warning followed by an alarm.

Troubleshooting

- If the motor torque limit is exceeded during ramp-up, extend the ramp-up time.
- If the generator torque limit is exceeded during ramp-down, extend the ramp-down time.
- If torque limit occurs while running, increase the torque limit. Make sure that the system can operate safely at a higher torque.
- Check the application for excessive current draw on the motor.

WARNING/ALARM 13, Over current

The inverter peak current limit (approximately 200% of the rated current) is exceeded. The warning lasts approximately 1.5 s, then the frequency converter trips and issues an alarm. Shock loading or quick acceleration with high-inertia loads can cause this fault. If the acceleration during ramp-up is quick, the fault can also appear after kinetic back-up.

If extended mechanical brake control is selected, a trip can be reset externally.

Troubleshooting

- Remove the power and check if the motor shaft can be turned.
- Check that the motor size matches the frequency converter.
- Check that the motor data is correct in *parameters 1-20 to 1-25*.

ALARM 14, Earth (ground) fault

There is current from the output phases to ground, either in the cable between the frequency converter and the motor, or in the motor itself.

Troubleshooting

- Remove the power to the frequency converter and repair the ground fault.
- Check for ground faults in the motor by measuring the resistance to the ground of the motor cables and the motor with a megohmmeter.
- Perform a current sensor test.

ALARM 15, Hardware mismatch

A fitted option is not operational with the present control board hardware or software.

Record the value of the following parameters and contact Danfoss:

- 15-40 FC Type
- 15-41 Power Section
- 15-42 Voltage
- 15-43 Software Version
- 15-45 Actual Typecode String
- 15-49 SW ID Control Card
- 15-50 SW ID Power Card
- 15-60 Option Mounted
- 15-61 Option SW Version (for each option slot)

ALARM 16, Short circuit

There is short-circuiting in the motor or motor wiring.

Troubleshooting

- Remove the power to the frequency converter and repair the short-circuit.

WARNING/ALARM 17, Control word timeout

There is no communication with the frequency converter. The warning is only active when 8-04 Control Word Timeout Function is not set to [0] Off.

If 8-04 Control Word Timeout Function is set to [2] Stop and [26] Trip, a warning appears and the frequency converter ramps down until it trips and then displays an alarm.

Troubleshooting

- Check the connections on the serial communication cable.
- Increase 8-03 Control Word Timeout Time
- Check the operation of the communication equipment.
- Verify a proper installation based on EMC requirements.

WARNING/ALARM 22, Hoist mechanical brake

Report value shows what kind it is.

0 = The torque reference was not reached before timeout (2-27 Torque Ramp Time).

1 = Expected brake feedback not received before timeout (2-23 Activate Brake Delay, 2-25 Brake Release Time).

WARNING 23, Internal fan fault

The fan warning function is an extra protective function that checks if the fan is running/mounted. The fan warning can be disabled in 14-53 Fan Monitor ([0] Disabled).

Troubleshooting

- Check the fan resistance.
- Check the soft charge fuses.

WARNING 24, External fan fault

The fan warning function is an extra protective function that checks if the fan is running/mounted. The fan warning can be disabled in 14-53 Fan Monitor ([0] Disabled).

Troubleshooting

- Check the fan resistance.
- Check the soft charge fuses.

WARNING 25, Brake resistor short circuit

The brake resistor is monitored during operation. If a short-circuit occurs, the brake function is disabled and the warning appears. The frequency converter is still operational, but without the brake function.

Troubleshooting

- Remove the power to the frequency converter and replace the brake resistor (see 2-15 Brake Check).

WARNING/ALARM 26, Brake resistor power limit

The power transmitted to the brake resistor is calculated as a mean value over the last 120 s of run time. The calculation is based on the intermediate circuit voltage and the brake resistance value set in 2-16 AC brake Max. Current. The warning is active when the dissipated braking is >90% of the brake resistance power. If [2] Trip is selected in 2-13 Brake Power Monitoring, the frequency converter trips when the dissipated braking power reaches 100%.

WARNING

If the brake transistor is short-circuited, there is a risk of substantial power being transmitted to the brake resistor.

WARNING/ALARM 27, Brake chopper fault

The brake transistor is monitored during operation. If a short-circuit occurs, the brake function is disabled and a warning is issued. The frequency converter is still operational, but since the brake transistor has short-circuited, substantial power is transmitted to the brake resistor, even if it is inactive.

Remove the power to the frequency converter and remove the brake resistor.

This alarm/warning could also occur if the brake resistor overheats. Terminals 104 and 106 are available as brake resistors Klixon inputs.

WARNING/ALARM 28, Brake check failed

The brake resistor is not connected or not working. Check 2-15 Brake Check.

7

ALARM 29, Heat Sink temp

The maximum temperature of the heat sink has been exceeded. The temperature fault resets when the temperature falls below a defined heat sink temperature. The trip and reset points vary based on the frequency converter power size.

Troubleshooting

Check for the following conditions.

- Ambient temperature too high.
- Motor cables too long.
- Incorrect airflow clearance above and below the frequency converter.
- Blocked airflow around the frequency converter.
- Damaged heat sink fan.
- Dirty heat sink.

For D, E, and F enclosures, this alarm is based on the temperature measured by the heat sink sensor mounted inside the IGBT modules. For the F enclosures, the thermal sensor in the rectifier module can also cause this alarm.

Troubleshooting

- Check the fan resistance.
- Check the soft charge fuses.
- Check the IGBT thermal sensor.

ALARM 30, Motor phase U missing

Motor phase U between the frequency converter and the motor is missing.

Troubleshooting

- Remove the power from the frequency converter and check motor phase U.

ALARM 31, Motor phase V missing

Motor phase V between the frequency converter and the motor is missing.

Troubleshooting

- Remove the power from the frequency converter and check motor phase V.

ALARM 32, Motor phase W missing

Motor phase W between the frequency converter and the motor is missing.

Troubleshooting

- Remove the power from the frequency converter and check motor phase W.

ALARM 33, Inrush fault

Too many power-ups have occurred within a short time period.

Troubleshooting

- Let the unit cool to operating temperature.

WARNING/ALARM 34, Fieldbus communication fault

The fieldbus on the communication option card is not working.

WARNING/ALARM 36, Mains failure

This warning/alarm is only active if the supply voltage to the frequency converter is lost and *14-10 Mains Failure* is not set to option [0] *No Function*. Check the fuses to the frequency converter and mains supply to the unit.

ALARM 38, Internal fault

When an internal fault occurs, a code number defined in *Table 7.5* is displayed.

Troubleshooting

- Cycle the power.
- Check that the option is properly installed.
- Check for loose or missing wiring.

It may be necessary to contact Danfoss Service or the supplier. Note the code number for further troubleshooting directions.

Number	Text
0	The serial port cannot be initialised. Contact your Danfoss supplier or Danfoss Service.
256–258	The power EEPROM data is defective or too old.
512	The control board EEPROM data is defective or too old.
513	Communication time-out reading EEPROM data
514	Communication time-out reading EEPROM data
515	Application-oriented control cannot recognise the EEPROM data.
516	Cannot write to the EEPROM because a write command is in progress.
517	The write command is under time-out.
518	Failure in the EEPROM.
519	Missing or invalid barcode data in EEPROM.
783	Parameter value outside of minimum/maximum limits.
1024–1279	A CAN telegram could not be sent.
1281	Digital signal processor flash time-out.
1282	Power micro software version mismatch.
1283	Power EEPROM data version mismatch.
1284	Cannot read digital signal processor software version.
1299	The option software in slot A is too old.
1300	The option software in slot B is too old.
1301	The option software in slot C0 is too old.
1302	The option software in slot C1 is too old.
1315	The option software in slot A is not supported (not allowed).
1316	The option software in slot B is not supported (not allowed).
1317	The option software in slot C0 is not supported (not allowed).
1318	The option software in slot C1 is not supported (not allowed).
1379	Option A did not respond when calculating the platform version

Number	Text
1380	Option B did not respond when calculating the platform version.
1381	Option C0 did not respond when calculating the platform version.
1382	Option C1 did not respond when calculating the platform version.
1536	An exception in the application-oriented control is registered. The debug information is written on the LCP.
1792	DSP Watch Dog is active. Debugging of power part data, motor-oriented control data not transferred correctly.
2049	Power data restarted.
2064–2072	H081x: Option in slot x has restarted.
2080–2088	H082x: Option in slot x has issued a power-up wait.
2096–2104	H983x: Option in slot x has issued a legal power-up wait.
2304	Could not read any data from the power EEPROM.
2305	Missing software version from the power unit.
2314	Missing power unit data from the power unit.
2315	Missing software version from the power unit.
2316	Missing lo_statepage from the power unit.
2324	The power card configuration is determined to be incorrect at power-up.
2325	A power card has stopped communicating while mains power is applied.
2326	The power card configuration is determined to be incorrect after the delay for power cards to register.
2327	Too many power card locations have been registered as present.
2330	The power size information between the power cards does not match.
2561	No communication from DSP to ATACD.
2562	No communication from ATACD to DSP (state running).
2816	Stack overflow control board module
2817	Scheduler slow tasks
2818	Fast tasks
2819	Parameter thread
2820	LCP stack overflow
2821	Serial port overflow
2822	USB port overflow
2836	cflistMempool is too small.
3072–5122	The parameter value is outside its limits.
5123	Option in slot A: Hardware incompatible with the control board hardware.
5124	Option in slot B: Hardware incompatible with the control board hardware.
5125	Option in slot C0: Hardware incompatible with the control board hardware.
5126	Option in slot C1: Hardware incompatible with the control board hardware.

Number	Text
5376–6231	Out of memory

Table 7.5 Internal Fault, Code Numbers

ALARM 39, Heat sink sensor

No feedback from the heat sink temperature sensor.

The signal from the IGBT thermal sensor is not available on the power card. The problem could be on the power card, on the gate drive card, or the ribbon cable between the power card and gate drive card.

WARNING 40, Overload of digital output terminal 27

Check the load connected to terminal 27 or remove the short-circuit connection. Check *5-00 Digital I/O Mode* and *5-01 Terminal 27 Mode*.

WARNING 41, Overload of digital output terminal 29

Check the load connected to terminal 29 or remove the short-circuit connection. Check *5-00 Digital I/O Mode* and *5-02 Terminal 29 Mode*.

WARNING 42, Overload of digital output on X30/6 or overload of digital output on X30/7

For X30/6, check the load connected to X30/6 or remove the short-circuit connection. Check *5-32 Term X30/6 Digi Out (MCB 101)*.

For X30/7, check the load connected to X30/7 or remove the short-circuit connection. Check *5-33 Term X30/7 Digi Out (MCB 101)*.

ALARM 45, Earth fault 2

Ground fault.

Troubleshooting

- Check for proper grounding and loose connections.
- Check for proper wire size.
- Check the motor cables for short circuits or leakage currents.

ALARM 46, Power card supply

The supply on the power card is out of range.

There are 3 power supplies generated by the switch mode power supply (SMPS) on the power card: 24 V, 5 V, and ±18 V. When powered with 24 V DC with the MCB 107 option, only the 24 V and 5 V supplies are monitored. When powered with 3-phase mains voltage, all 3 supplies are monitored.

WARNING 47, 24 V supply low

The 24 V DC is measured on the control card. This alarm appears when the detected voltage of terminal 12 is <18 V.

Troubleshooting

- Check for a defective control card.

WARNING 48, 1.8 V supply low

The 1.8 V DC supply used on the control card is outside of the allowable limits. The power supply is measured on the control card. Check for a defective control card. If an option card is present, check for overvoltage.

WARNING 49, Speed limit

When the speed is outside of the specified range in 4-11 *Motor Speed Low Limit [RPM]* and 4-13 *Motor Speed High Limit [RPM]*, the frequency converter shows a warning. When the speed is below the specified limit in 1-86 *Trip Speed Low [RPM]* (except when starting or stopping), the frequency converter trips.

ALARM 50, AMA calibration failed

Contact the Danfoss supplier or Danfoss Service.

ALARM 51, AMA check U_{nom} and I_{nom}

The settings for motor voltage, motor current and motor power are wrong. Check the settings in *parameters 1-20 to 1-25*.

ALARM 52, AMA low I_{nom}

The motor current is too low. Check the settings in 4-18 *Current Limit*.

ALARM 53, AMA motor too big

The motor is too big for the AMA to operate.

ALARM 54, AMA motor too small

The motor is too small for the AMA to operate.

ALARM 55, AMA parameter out of range

The parameter values of the motor are outside of the acceptable range. AMA cannot run.

ALARM 56, AMA interrupted by user

The user has interrupted AMA.

ALARM 57, AMA internal fault

Continue to restart the AMA, until the AMA is carried out.

NOTICE

Repeated runs may heat the motor to a level where the resistance R_s and R_r are increased. In most cases, however, this behaviour is not critical.

ALARM 58, AMA Internal fault

Contact the Danfoss supplier.

WARNING 59, Current limit

The current is higher than the value in 4-18 *Current Limit*. Ensure that motor data in *parameters 1-20 to 1-25* are set correctly. Increase the current limit if necessary. Ensure that the system can operate safely at a higher limit.

WARNING 60, External interlock

External interlock has been activated. To resume normal operation, apply 24 V DC to the terminal programmed for external interlock and reset the frequency converter (via serial communication, digital I/O, or by pressing [Reset]).

WARNING/ALARM 61, Tracking error

An error has occurred between the calculated motor speed and the speed measurement from the feedback device. The function warning/alarm/disable is set in 4-30 *Motor Feedback Loss Function*. Accepted error setting in 4-31 *Motor Feedback Speed Error* and the allowed time the error occur setting in 4-32 *Motor Feedback Loss Timeout*. During a commissioning procedure, the function could be effective.

WARNING 62, Output frequency at maximum limit

The output frequency is higher than the value set in 4-19 *Max Output Frequency*.

ALARM 63, Mechanical brake low

The actual motor current has not exceeded the release brake current within the start delay time window.

ALARM 64, Voltage Limit

The load and speed combination demands a motor voltage higher than the actual DC-link voltage.

WARNING/ALARM 65, Control card over temperature

The cut-out temperature of the control card is 80 °C.

Troubleshooting

- Check that the ambient operating temperature is within the limits.
- Check for clogged filters.
- Check the fan operation.
- Check the control card.

WARNING 66, Heat sink temperature low

The frequency converter is too cold to operate. This warning is based on the temperature sensor in the IGBT module.

Increase the ambient temperature of the unit. Also, a trickle amount of current can be supplied to the frequency converter whenever the motor is stopped by setting 2-00 *DC Hold/Preheat Current* at 5% and 1-80 *Function at Stop*.

Troubleshooting

The heat sink temperature measured as 0 °C could indicate that the temperature sensor is defective, causing the fan speed to increase to the maximum. This warning results if the sensor wire between the IGBT and the gate drive card is disconnected. Also, check the IGBT thermal sensor.

ALARM 67, Option module configuration has changed

One or more options have either been added or removed since the last power-down. Check that the configuration change is intentional and reset the unit.

ALARM 68, Safe Stop activated

STO has been activated. To resume normal operation, apply 24 V DC to terminal 37, then send a reset signal (via bus, digital I/O, or by pressing [Reset]).

ALARM 69, Power card temperature

The temperature sensor on the power card is either too hot or too cold.

Troubleshooting

- Check the operation of the door fans.
- Check that the filters for the door fans are not blocked.
- Check that the gland plate is properly installed on IP21/IP54 (NEMA 1/12) frequency converters.

ALARM 70, Illegal FC configuration

The control card and power card are incompatible. To check compatibility, contact the Danfoss supplier with the type code of the unit from the nameplate and the part numbers of the cards.

ALARM 71, PTC 1 Safe Torque Off

STO has been activated from the VLT[®] PTC Thermistor Card MCB 112 (motor too warm). Normal operation can resume when the VLT[®] PTC Thermistor Card MCB 112 applies 24 V DC to terminal 37 (when the motor temperature is acceptable) and when the digital input from the VLT[®] PTC Thermistor Card MCB 112 is deactivated. When that happens, a reset signal is sent (via Bus, Digital I/O, or by pressing [Reset]).

NOTICE

If automatic restart is enabled, the motor could start when the fault is cleared.

ALARM 72, Dangerous failure

STO with trip lock. Unexpected signal levels on safe stop and digital input from the VLT[®] PTC Thermistor Card MCB 112.

WARNING 73, Safe Stop auto restart

Safe stopped. With automatic restart enabled, the motor can start when the fault is cleared.

WARNING 76, Power unit setup

The required number of power units does not match the detected number of active power units.

WARNING 77, Reduced power mode

The frequency converter is operating in reduced power mode (less than the allowed number of inverter sections). This warning is generated on power cycle when the frequency converter is set to run with fewer inverters and remains on.

ALARM 79, Illegal power section configuration

The scaling card has an incorrect part number or is not installed. The MK102 connector on the power card could not be installed.

ALARM 80, Drive initialised to default value

Parameter settings are initialised to default settings after a manual reset. To clear the alarm, reset the unit.

ALARM 81, CSIV corrupt

CSIV file has syntax errors.

ALARM 82, CSIV parameter error

CSIV failed to initialise a parameter.

ALARM 85, Dang fail PB

PROFIBUS/PROFIsafe error.

WARNING/ALARM 104, Mixing fan fault

The fan is not operating. The fan monitor checks that the fan is spinning at power-up or whenever the mixing fan is turned on. The mixing-fan fault can be configured as a warning or an alarm trip in *14-53 Fan Monitor*.

Troubleshooting

- Cycle power to the frequency converter to determine if the warning/alarm returns.

ALARM 243, Brake IGBT

This alarm is only for enclosure size F frequency converters. It is equivalent to Alarm 27. The report value in the alarm log indicates which power module generated the alarm:

- 1 = Left most inverter module.
- 2 = Middle inverter module in enclosure sizes F12 or F3.
- 2 = Right inverter module in enclosure sizes F10 or F11.
- 2 = Second frequency converter from the left inverter module in enclosure size F14.
- 3 = Right inverter module in enclosure sizes F12 or F13.
- 3 = Third from the left inverter module in enclosure size F14.
- 4 = Far right inverter module in enclosure size F14.
- 5 = Rectifier module.
- 6 = Right rectifier module in enclosure size F14.

ALARM 244, Heat Sink temperature

This alarm is only for enclosure type F frequency converters. It is equivalent to Alarm 29. The report value in the alarm log indicates which power module generated the alarm:

- 1 = Left most inverter module.
- 2 = Middle inverter module in enclosure size F12 or F3.
- 2 = Right inverter module in enclosure size F10 or F11.
- 2 = Second frequency converter from the left inverter module in enclosure size F14.
- 3 = Right inverter module in enclosure sizes F12 or F13.
- 3 = Third from the left inverter module in enclosure size F14.
- 4 = Far right inverter module in enclosure sizes F14.
- 5 = Rectifier module.
- 6 = Right rectifier module in enclosure sizes F14.

ALARM 245, Heat Sink sensor

This alarm is only for enclosure size F frequency converters. It is equivalent to Alarm 39. The report value in the alarm log indicates which power module generated the alarm:

- 1 = Left most inverter module.
- 2 = Middle inverter module in enclosure sizes F12 or F13.
- 2 = Right inverter module in enclosure sizes F10 or F11.
- 2 = Second frequency converter from the left inverter module in enclosure size F14.
- 3 = Right inverter module in enclosure sizes F12 or F13.
- 3 = Third from the left inverter module in enclosure size F14.
- 4 = Far right inverter module in enclosure size F14.
- 5 = Rectifier module.
- 6 = Right rectifier module in enclosure size F14.

ALARM 246, Power card supply

This alarm is only for enclosure size F frequency converters. It is equivalent to Alarm 46. The report value in the alarm log indicates which power module generated the alarm:

- 1 = Left most inverter module.
- 2 = Middle inverter module in enclosure sizes F12 or F13.
- 2 = Right inverter module in enclosure sizes F10 or F11.
- 2 = Second frequency converter from the left inverter module in enclosure size F14.
- 3 = Right inverter module in enclosure sizes F12 or F13.
- 3 = Third from the left inverter module in enclosure size F14.
- 4 = Far right inverter module in enclosure size F14.
- 5 = Rectifier module.
- 6 = Right rectifier module in enclosure size F14.

ALARM 247, Power card temperature

This alarm is only for enclosure size F frequency converters. It is equivalent to Alarm 69. The report value in the alarm log indicates which power module generated the alarm:

- 1 = Left most inverter module.
- 2 = Middle inverter module in enclosure sizes F12 or F13.

2 = Right inverter module in enclosure sizes F10 or F11.

2 = Second frequency converter from the left inverter module in enclosure size F14.

3 = Right inverter module in enclosure sizes F12 or F13.

3 = Third from the left inverter module in enclosure size F14.

4 = Far right inverter module in enclosure size F14.

5 = Rectifier module.

6 = Right rectifier module in enclosure size F14.

ALARM 248, Illegal power section configuration

This alarm is only for enclosure size F frequency converters. It is equivalent to Alarm 79. The report value in the alarm log indicates which power module generated the alarm:

- 1 = Left most inverter module.
- 2 = Middle inverter module in enclosure sizes F12 or F13.
- 2 = Right inverter module in enclosure sizes F10 or F11.
- 2 = Second frequency converter from the left inverter module in enclosure size F14.
- 3 = Right inverter module in enclosure sizes F12 or F13.
- 3 = Third from the left inverter module in enclosure sizes F14.
- 4 = Far right inverter module in enclosure sizes F14.
- 5 = Rectifier module.
- 6 = Right rectifier module in enclosure size F14.

WARNING 250, New spare part

A component in the frequency converter has been replaced.

Troubleshooting

- Reset the frequency converter for normal operation.

WARNING 251, New typecode

The power card or other components have been replaced and the typecode has been changed.

Troubleshooting

- Reset to remove the warning and resume normal operation.

7.4 Active Filter Warning and Alarm Definitions

NOTICE

After a manual reset pressing [Reset], press [Auto On] or [Hand On] to restart the unit.

If an alarm cannot be reset, the reason may be that its cause has not been rectified, or the alarm is trip-locked (see also Table 7.6).

Alarms that are trip-locked offer additional protection, meaning that the mains supply must be switched off before the alarm can be reset. After being switched back on, the unit is no longer blocked and may be reset as described above once the cause has been rectified.

Alarms that are not trip-locked can also be reset using the automatic reset function in *14-20 Reset Mode* (Warning: automatic wake-up is possible)

If a warning and alarm is marked against a code in Table 7.6, either a warning occurs before an alarm, or it can be specified whether it is a warning or an alarm that is to be displayed for a given fault.

No.	Description	Warning	Alarm/Trip	Alarm/Trip Lock	Parameter Reference
1	10 Volts low	X			
2	Live zero error	(X)	(X)		6-01
4	Mains phase loss	X			
5	DC link voltage high	X			
6	DC link voltage low	X			
7	DC over voltage	X	X		
8	DC under voltage	X	X		
13	Over current	X	X	X	
14	Earth fault	X	X	X	
15	Hardware mismatch		X	X	
16	Short circuit		X	X	
17	Control word timeout	(X)	(X)		8-04
23	Internal fan fault	X			
24	External fan fault	X			14-53
29	Heatsink temp	X	X	X	
33	Inrush fault		X	X	
34	Fieldbus fault	X	X		
35	Option fault	X	X		
38	Internal fault				
39	Heatsink sensor		X	X	
40	Overload of digital output terminal 27	(X)			5-00, 5-01
41	Overload of digital output terminal 29	(X)			5-00, 5-02
46	Pwr. card supply		X	X	
47	24 V supply low	X	X	X	
48	1.8 V supply low		X	X	
65	Control board over-temperature	X	X	X	
66	Heat sink temperature low	X			
67	Option configuration has changed		X		
68	Safe torque off activated		X ¹⁾		
69	Pwr. card temp		X	X	
70	Illegal FC configuration			X	
72	Dangerous Failure			X ¹⁾	
73	Safe torque off auto restart				
76	Power unit setup	X			

No.	Description	Warning	Alarm/Trip	Alarm/Trip Lock	Parameter Reference
79	Illegal PS config		X	X	
80	Unit initialised to default value		X		
250	New spare part			X	
251	New type code		X	X	
300	Mains cont. fault	X			
301	SC cont. fault	X			
302	Cap. over current	X	X		
303	Cap. earth fault	X	X		
304	DC over current	X	X		
305	Mains freq. limit		X		
306	Compensation Limit				
308	Resistor temp	X		X	
309	Mains earth fault	X	X		
311	Switch. freq. limit		X		
312	CT range		X		
314	Auto CT interrupt		X		
315	Auto CT error		X		
316	CT location error	X			
317	CT polarity error	X			
318	CT ratio error	X			

Table 7.6 Alarm/Warning Code List

A trip is the action when an alarm has appeared. The trip disables the active filter and can be reset by pressing [Reset] or make a reset by a digital input (parameter group 5-1* *Digital Inputs [1] Reset*). The origin event that caused an alarm cannot damage the active filter or cause dangerous conditions. A trip lock is an action when an alarm occurs, which may cause damage to active filter or connected parts. A Trip Lock situation can only be reset by a power cycling.

Warning	yellow
Alarm	flashing red
Trip locked	yellow and red

Table 7.7 LED Indicator Lights

Alarm Word and Extended Status Word					
Bit	Hex	Dec	Alarm Word	Warning Word	Extended Status Word
0	00000001	1	Mains cont. fault	Reserved	Reserved
1	00000002	2	Heatsink temp	Heatsink temp	Auto CT running
2	00000004	4	Ground fault	Ground fault	Reserved
3	00000008	8	Ctrl.card temp	Ctrl.card temp	Reserved
4	00000010	16	Ctrl. word TO	Ctrl. word TO	Reserved
5	00000020	32	Over current	Over current	Reserved
6	00000040	64	SC cont. fault	Reserved	Reserved
7	00000080	128	Cap. over current	Cap. over current	Reserved
8	00000100	256	Cap. earth fault	Cap. earth fault	Reserved
9	00000200	512	Inverter overld.	Inverter overld.	Reserved
10	00000400	1024	DC under volt	DC under volt	Reserved
11	00000800	2048	DC over volt	DC over volt	Reserved
12	00001000	4096	Short circuit	DC voltage low	Reserved
13	00002000	8192	Inrush fault	DC voltage high	Reserved
14	00004000	16384	Mains ph. loss	Mains ph. loss	Reserved
15	00008000	32768	Auto CT error	Reserved	Reserved
16	00010000	65536	Reserved	Reserved	Reserved
17	00020000	131072	Internal fault	10V low	Password Time Lock
18	00040000	262144	DC over current	DC over current	Password Protection
19	00080000	524288	Resistor temp	Resistor temp	Reserved
20	00100000	1048576	Mains earth fault	Mains earth fault	Reserved
21	00200000	2097152	Switch. freq. limit	Reserved	Reserved
22	00400000	4194304	Fieldbus fault	Fieldbus fault	Reserved
23	00800000	8388608	24 V supply low	24V supply low	Reserved
24	01000000	16777216	CT range	Reserved	Reserved
25	02000000	33554432	1.8V supply low	Reserved	Reserved
26	04000000	67108864	Reserved	Low temp	Reserved
27	08000000	134217728	Auto CT interrupt	Reserved	Reserved
28	10000000	268435456	Option change	Reserved	Reserved
29	20000000	536870912	Unit initialized	Unit initialized	Reserved
30	40000000	1073741824	Safe torque off	Safe torque off	Reserved
31	80000000	2147483648	Mains freq. limit	Extended status word	Reserved

7

Table 7.8 Description of Alarm Word, Warning Word and Extended Status Word

The alarm words, warning words and extended status words can be read out via serial bus or optional fieldbus for diagnosis. See also *16-90 Alarm Word*, *16-92 Warning Word* and *16-94 Ext. Status Word*. Reserved means that the bit is not guaranteed to be any particular value. Reserved bits should not be used for any purpose.

7.4.1 Fault Messages for Active Filter

WARNING 1, 10 volts low

The control card voltage is below 10 V from terminal 50. Remove some of the load from terminal 50, as the 10 V supply is overloaded. Max. 15 mA or minimum 590 Ω. Fault messages - active filter

WARNING/ALARM 2, Live zero error

The signal on terminal 53 or 54 is less than 50% of the value set in parameters 6-10, 6-12, 6-20 or 6-22.

WARNING 4, Mains phase loss

A phase is missing on the supply side, or the mains voltage imbalance is too high.

WARNING 5, DC link voltage high

The intermediate circuit voltage (DC) is higher than the high-voltage warning limit. The unit is still active.

WARNING 6, DC link voltage low

The intermediate circuit voltage (DC) is below the low-voltage warning limit. The unit is still active.

WARNING/ALARM 7, DC overvoltage

If the intermediate circuit voltage exceeds the limit, the unit trips.

WARNING/ALARM 8, DC under voltage

If the intermediate circuit voltage (DC) drops below the under voltage limit, the filter checks if a 24 V back-up supply is connected. If not, the filter trips. Check that the mains voltage matches the nameplate specification.

WARNING/ALARM 13, Over Current

the unit current limit has been exceeded.

ALARM 14, Earth (ground) fault

The sum current of the IGBT CTs does not equal zero. Check if the resistance of any phase to ground has a low value. Check both before and after mains contactor. Ensure IGBT current transducers, connection cables, and connectors are ok.

ALARM 15, Incomp. Hardware

A mounted option is incompatible with the present control card SW/HW.

ALARM 16, Short circuit

There is a short-circuit in the output. Turn off the unit and correct the error.

WARNING/ALARM 17, Control word timeout

There is no communication to the unit.

The warning is only active when *8-04 Control Word Timeout Function* is not set to off.

Possible correction: Increase *8-03 Control Word Timeout Time*. Change *8-04 Control Word Timeout Function*

WARNING 23, Internal fan fault

Internal fans have failed due to defect hardware or fans not mounted.

WARNING 24, External fan fault

External fans have failed due to defect hardware or fans not mounted.

ALARM 29, Heat sink temp

The maximum temperature of the heat sink has been exceeded. The temperature fault is not reset until the temperature falls below a defined heat sink temperature.

ALARM 33, Inrush fault

Check whether a 24 V external DC supply has been connected.

WARNING/ALARM 34, Fieldbus communication fault

The fieldbus on the communication option card is not working.

WARNING/ALARM 35, Option Fault:

Contact Danfoss or supplier.

ALARM 38, Internal fault

Contact Danfoss or supplier.

ALARM 39, Heat sink sensor

No feedback from the heat sink temperature sensor.

WARNING 40, Overload of Digital Output Terminal 27

Check the load connected to terminal 27 or remove short-circuit connection.

WARNING 41, Overload of Digital Output Terminal 29

Check the load connected to terminal 29 or remove short-circuit connection.

ALARM 46, Power card supply

The supply on the power card is out of range.

WARNING 47, 24 V supply low

Contact Danfoss or supplier.

WARNING 48, 1.8 V supply low

Contact Danfoss or supplier.

WARNING/ALARM/TRIP 65, Control card over temperature

Control card over temperature: The cut-out temperature of the control card is 80 °C.

WARNING 66, Heat sink temperature low

This warning is based on the temperature sensor in the IGBT module.

Troubleshooting

The heat sink temperature measured as 0 °C could indicate that the temperature sensor is defective, causing the fan speed to increase to the maximum. If the sensor wire between the IGBT and the gate drive card is disconnected, this warning would result. Also, check the IGBT thermal sensor.

ALARM 67, Option module configuration has changed

One or more options have either been added or removed since the last power-down.

ALARM 68, Safe Torque Off activated

Safe Torque Off has been activated. To resume normal operation, apply 24 V DC to terminal 37, then send a reset signal (via bus, digital I/O, or by pressing [Reset]). See *5-19 Terminal 37 Safe Stop*.

ALARM 69, Power card temperature

The temperature sensor on the power card is either too hot or too cold.

ALARM 70, Illegal FC Configuration

Actual combination of control board and power board is illegal.

ALARM 79, Illegal power section configuration

The scaling card is the incorrect part number or not installed. Also MK102 connector on the power card could not be installed.

ALARM 80, Unit initialised to default value

Parameter settings are initialised to default settings after a manual reset.

ALARM 247, Power card temperature

Power card over temperature. Report value indicates source of alarm (from left):

- 1-4 inverter
- 5-8 rectifier

ALARM 250, New spare part

The power or switch mode power supply has been exchanged. The filter type code must be restored in the EEPROM. Select the correct type code in *14-23 Typecode Setting* according to the label on the unit. Remember to select 'Save to EEPROM' to complete.

ALARM 251, New type code

The filter has a new type code.

ALARM 300, Mains Cont. Fault

The feedback from the mains contactor did not match the expected value within the allowed time frame. Contact Danfoss or supplier.

ALARM 301, SC Cont. Fault

The feedback from the soft charge contactor did not match the expected value within the allowed time frame. Contact Danfoss or supplier.

ALARM 302, Cap. Over Current

Excessive current was detected through the AC capacitors. Contact Danfoss or supplier.

ALARM 303, Cap. Earth Fault

An earth fault was detected through the AC capacitor currents. Contact Danfoss or supplier.

ALARM 304, DC Over Current

Excessive current through the DC-link capacitor bank was detected. Contact Danfoss or supplier.

ALARM 305, Mains Freq. Limit

The mains frequency was outside the limits. Verify that the mains frequency is within product specification.

ALARM 306, Compensation Limit

The needed compensation current exceeds unit capability. Unit is running at full compensation.

ALARM 308, Resistor temp

Excessive resistor heat sink temperature detected.

ALARM 309, Mains Earth Fault

An earth fault was detected in the mains currents. Check the mains for shorts and leakage current.

ALARM 310, RTDC Buffer Full

Contact Danfoss or supplier.

ALARM 311, Switch. Freq. Limit

The average switching frequency of the unit exceeded the limit. Verify that *300-10 Active Filter Nominal Voltage* and *300-22 CT Nominal Voltage* are set correctly. If so, contact Danfoss or supplier.

ALARM 312, CT Range

Current transformer measurement limitation was detected. Verify that the CTs used are an appropriate ratio.

ALARM 314, Auto CT Interrupt

Auto CT detection has been interrupted.

ALARM 315, Auto CT Error

An error was detected while performing auto CT detection. Contact Danfoss or supplier.

WARNING 316, CT Location Error

The auto CT function could not determine the correct locations of the CTs.

WARNING 317, CT Polarity Error

The auto CT function could not determine the correct polarity of the CTs.

WARNING 318, CT Ratio Error

The auto CT function could not determine the correct primary rating of the CTs.

7.5 Troubleshooting

Symptom	Possible cause	Test	Solution
Display dark/No function	Missing input power	See <i>Table 5.1</i>	Check the input power source
	Missing or open fuses or circuit breaker tripped	See <i>Open fuses and Tripped circuit breaker</i> in this table for possible causes	Follow the recommendations provided
	No power to the LCP	Check the LCP cable for proper connection or damage	Replace the faulty LCP or connection cable
	Shortcut on control voltage (terminal 12 or 50) or at control terminals	Check the 24 V control voltage supply for terminals 12/13 to 20-39 or 10 V supply for terminals 50 to 55	Wire the terminals properly
	Wrong LCP (LCP from VLT® 2800 or 5000/6000/8000/ FCD or FCM)		Use only LCP 101 (P/N 130B1124) or LCP 102 (P/N 130B1107)
	Wrong contrast setting		Press [Status] + [▲]/[▼] to adjust the contrast
	Display (LCP) is defective	Test using a different LCP	Replace the faulty LCP or connection cable
	Internal voltage supply fault or SMPS is defective		Contact supplier
Intermittent display	Overloaded power supply (SMPS) due to improper control wiring or a fault within the frequency converter	To rule out a problem in the control wiring, disconnect all control wiring by removing the terminal blocks.	If the display stays lit, then the problem is in the control wiring. Check the wiring for shorts or incorrect connections. If the display continues to cut out, follow the procedure for display dark.
Motor not running	Service switch open or missing motor connection	Check if the motor is connected and the connection is not interrupted (by a service switch or other device).	Connect the motor and check the service switch
	No mains power with 24 V DC option card	If the display is functioning but no output, check that mains power is applied to the frequency converter.	Apply mains power to run the unit
	LCP Stop	Check if [Off] has been pressed	Press [Auto On] or [Hand On] (depending on operation mode) to run the motor
	Missing start signal (Standby)	Check <i>5-10 Terminal 18 Digital Input</i> for correct setting for terminal 18 (use default setting)	Apply a valid start signal to start the motor
	Motor coast signal active (Coasting)	Check <i>5-12 Coast inv.</i> for correct setting for terminal 27 (use default setting).	Apply 24 V on terminal 27 or program this terminal to <i>no operation</i>
	Wrong reference signal source	Check reference signal: Local, remote or bus reference? Preset reference active? Terminal connection correct? Scaling of terminals correct? Reference signal available?	Program correct settings. Check <i>3-13 Reference Site</i> . Set preset reference active in parameter group <i>3-1* References</i> . Check for correct wiring. Check scaling of terminals. Check reference signal.
Motor running in wrong direction	Motor rotation limit	Check that <i>4-10 Motor Speed Direction</i> is programmed correctly.	Program correct settings
	Active reversing signal	Check if a reversing command is programmed for the terminal in parameter group <i>5-1* Digital inputs</i> .	Deactivate reversing signal
	Wrong motor phase connection		See <i>chapter 4.6.2 Motor Cable</i> in this manual

Symptom	Possible cause	Test	Solution
Motor is not reaching maximum speed	Frequency limits set wrong	Check output limits in 4-13 <i>Motor Speed High Limit [RPM]</i> , 4-14 <i>Motor Speed High Limit [Hz]</i> and 4-19 <i>Max Output Frequency</i> .	Program correct limits
	Reference input signal not scaled correctly	Check reference input signal scaling in 6-0* <i>Analog I/O Mode</i> and parameter group 3-1* <i>References</i> . Reference limits in parameter group 3-0* <i>Reference Limit</i> .	Program correct settings
Motor speed unstable	Possible incorrect parameter settings	Check the settings of all motor parameters, including all motor compensation settings. For closed loop operation, check PID settings.	Check settings in parameter group 1-6* <i>Load Depen. Setting</i> . For closed loop operation, check settings in parameter group 20-0* <i>Feedback</i> .
Motor runs rough	Possible overmagnetisation	Check for incorrect motor settings in all motor parameters	Check motor settings in parameter groups 1-2* <i>Motor Data</i> , 1-3* <i>Adv Motor Data</i> , and 1-5* <i>Load Indep. Setting</i> .
Motor will not brake	Possible incorrect settings in the brake parameters. Possible too short ramp down times	Check brake parameters. Check ramp time settings	Check parameter group 2-0* <i>DC Brake</i> and 3-0* <i>Reference Limits</i> .
Open power fuses or circuit breaker trip	Phase-to-phase short	Motor or panel has a short phase to phase. Check motor and panel phase for shorts	Eliminate any shorts detected
	Motor overload	Motor is overloaded for the application	Perform startup test and verify motor current is within specifications. If motor current is exceeding nameplate full load current, motor may run only with reduced load. Review the specifications for the application.
	Loose connections	Perform pre-startup check for loose connections	Tighten loose connections
Mains current imbalance greater than 3%	Problem with mains power (See <i>Alarm 4 Mains phase loss</i> description)	Rotate input power leads into the frequency converter one position: A to B, B to C, C to A.	If imbalanced leg follows the wire, it is a power problem. Check mains power supply.
	Problem with the frequency converter	Rotate input power leads into the frequency converter one position: A to B, B to C, C to A.	If imbalance leg stays on same input terminal, it is a problem with the unit. Contact the supplier.
Motor current imbalance greater than 3%	Problem with motor or motor wiring	Rotate output motor leads one position: U to V, V to W, W to U.	If imbalanced leg follows the wire, the problem is in the motor or motor wiring. Check motor and motor wiring.
	Problem with the frequency converters	Rotate output motor leads one position: U to V, V to W, W to U.	If imbalance leg stays on same output terminal, it is a problem with the unit. Contact the supplier.
Acoustic noise or vibration (e.g. a fan blade is making noise or vibrations at certain frequencies)	Resonances, e.g. in the motor/fan system	Bypass critical frequencies by using parameters in parameter group 4-6* <i>Speed Bypass</i>	Check if noise and/or vibration have been reduced to an acceptable limit
		Turn off over-modulation in 14-03 <i>Overmodulation</i>	
		Change switching pattern and frequency in parameter group 14-0* <i>Inverter Switching</i>	
		Increase Resonance Dampening in 1-64 <i>Resonance Damping</i>	

Table 7.9 Troubleshooting

8 Specifications

8.1 Power-Dependent Specifications

8.1.1 Mains Supply 3x380-480 V AC

	P160	P200	P250
Normal Overload =110% current for 60 s	NO	NO	NO
Typical shaft output at 400 V [kW]	160	200	250
Typical shaft output at 460 V [hp]	250	300	350
Typical shaft output at 480 V [kW]	200	250	315
Enclosure IP21/54	D13		
Output current			
Continuous (at 400 V) [A]	315	395	480
Intermittent (60 s overload) (at 400 V) [A]	347	435	528
Continuous (at 460/480 V) [A]	302	361	443
Intermittent (60 s overload) (at 460/480 V) [A]	332	397	487
Continuous kVA (at 400 V) [kVA]	218	274	333
Continuous kVA (at 460 V) [kVA]	241	288	353
Continuous kVA (at 480 V) [kVA]	262	313	384
Max. Input current			
Continuous (at 400 V) [A]	304	381	463
Continuous (at 460/480 V) [A]	291	348	427
Max. pre-fuses ¹⁾ [A]	400	500	630
Max. cable size			
Motor (mm ² /AWG ²⁾)	2x185 (2x300 mcm)		
Mains (mm ² /AWG ²⁾)			
Brake (mm ² /AWG ²⁾)			
Total LHD loss 400 V AC [kW]	8868	10527	11751
Total back channel loss 400 V AC [kW]	7318	8903	10033
Total filter loss 400 V AC [kW]	4954	5714	6234
Total LHD loss 460 V AC [kW]	9059	10192	11706
Total back channel loss 460 V AC [kW]	7123	8209	9635
Total filter loss 460 V AC [kW]	5279	5819	6681
Weight, enclosure IP21, IP54 [kg]	380		406
Efficiency ⁴⁾	0.96		
Output frequency [Hz]	0-800		
Heatsink overtemp. trip [°C]	105		
Power card ambient trip [°C]	85		

*High overload = 160% torque during 60 s; Normal overload = 110% torque during 60 s

Table 8.1 Mains Supply 3x380-480 V AC

	P315	P355	P400	P450
Normal Overload = 110% current for 60 s	NO	NO	NO	NO
Typical shaft output at 400 V [kW]	315	355	400	450
Typical shaft output at 460 V [hp]	450	500	600	600
Typical shaft output at 480 V [kW]	355	400	500	530
Enclosure IP21/54	E9			
Output current				
Continuous (at 400 V) [A]	600	658	745	800
Intermittent (60 s overload) (at 400 V) [A]	660	724	820	880
Continuous (at 460/480 V) [A]	540	590	678	730
Intermittent (60 s overload) (at 460/480 V) [A]	594	649	746	803
Continuous kVA (at 400 V) [kVA]	416	456	516	554
Continuous kVA (at 460 V) [kVA]	430	470	540	582
Continuous kVA (at 480 V) [kVA]	468	511	587	632
Max. input current				
Continuous (at 400 V) [A]	590	647	733	787
Continuous (at 460/480 V) [A]	531	580	667	718
Max. pre-fuses ¹⁾ [A]	700	900		
Max. cable size				
Motor (mm ² /AWG ²⁾)	4x240 (4x500 mcm)			
Mains (mm ² /AWG ²⁾)				
Brake (mm ² /AWG ²⁾)	2x185 (2x350 mcm)			
Total LHD loss 400 V AC [kW]	14051	15320	17180	18447
Total back channel loss 400 V AC [kW]	11301	11648	13396	14570
Total filter loss 400 V AC [kW]	7346	7788	8503	8974
Total LHD loss 460 V AC [kW]	12936	14083	15852	16962
Total back channel loss 460 V AC [kW]	10277	10522	12184	13214
Total filter loss 460 V AC [kW]	7066	7359	8033	8435
Weight, enclosure IP21, IP54 [kg]	596	623	646	
Efficiency ⁴⁾	0.96			
Output frequency [Hz]	0-600			
Heatsink overtemp. trip [°C]	105			
Power card ambient trip [°C]	85			
*High overload = 160% torque during 60 s; Normal overload = 110% torque during 60 s				

Table 8.2 Mains Supply 3x380-480 V AC

	P500	P560	P630	P710
Normal Overload =110% current for 60 s	NO	NO	NO	NO
Typical shaft output at 400 V [kW]	500	560	630	710
Typical shaft output at 460 V [hp]	650	750	900	1000
Typical shaft output at 480 V [kW]	560	630	710	800
Enclosure IP21/54	F18			
Output current				
Continuous (at 400 V) [A]	880	990	1120	1260
Intermittent (60 s overload) (at 400 V) [A]	968	1089	1232	1386
Continuous (at 460/480 V) [A]	780	890	1050	1160
Intermittent (60 s overload) (at 460/480 V) [A]	858	979	1155	1276
Continuous kVA (at 400 V) [kVA]	610	686	776	873
Continuous kVA (at 460 V) [kVA]	621	709	837	924
Continuous kVA (at 480 V) [kVA]	675	771	909	1005
Max. Input current				
Continuous (at 400 V) [A]	857	964	1090	1227
Continuous (at 460/480 V) [A]	759	867	1022	1129
Max. pre-fuses ¹⁾ [A]	1600		2000	
Max. cable size				
Motor (mm ² /AWG ²⁾)	8 x 150 (8 x 300 mcm)			
Mains (mm ² /AWG ²⁾)	8 x 240 (8 x 500 mcm)			
Brake (mm ² /AWG ²⁾)	4 x 185 (4 x 350 mcm)			
Total LHD loss 400 V AC [kW]	21909	24592	26640	30519
Total back channel loss 400 V AC [kW]	17767	19984	21728	24936
Total filter loss 400 V AC [kW]	11747	12771	14128	15845
Total LHD loss 460 V AC [kW]	19896	22353	25030	27989
Total back channel loss 460 V AC [kW]	16131	18175	20428	22897
Total filter loss 460 V AC [kW]	11020	11929	13435	14776
Weight, enclosure IP21, IP54 [kg]	2009			
Efficiency ⁴⁾	0.96			
Output frequency [Hz]	0-600			
Heatsink overtemp. trip [°C]	105			
Power card ambient trip [°C]	85			
*Normal overload = 110% torque during 60 s				

Table 8.3 Mains Supply 3x380-480 V AC

1) For type of fuse, see *chapter 8.5.1 Fuses*.

2) American wire gauge.

3) Measured using 5 m screened motor cables at rated load and rated frequency.

4) The typical power loss is at nominal load conditions and expected to be within $\pm 15\%$ (tolerance relates to variety in voltage and cable conditions). Values are based on a typical motor efficiency (IE2/IE3 border line). Motors with lower efficiency also add to the power loss in the frequency converter and opposite. If the switching frequency is increased to the default setting, the power losses may rise significantly. LCP and typical control card power consumptions are included. Further options and customer load may add up to 30 W to the losses. (Though typical only 4 W extra for a fully loaded control card, or options for slot A or slot B, each).

Although measurements are made with state-of-the-art equipment, some measurement inaccuracy must be allowed for ($\pm 5\%$).

8.1.2 Derating for Temperature

The frequency converter automatically derates the switching frequency, switching type, or output current under certain load or ambient conditions as described below. The derating curves in *Illustration 8.1* apply to both SFAVM and 60 AVM switching modes.

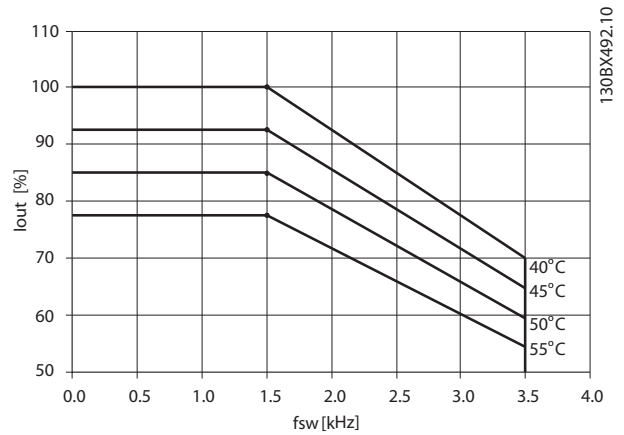

Illustration 8.1 Derating Frame Sizes D, E, and F 380-500 V (T5) Normal Overload 110%

8.2 Mechanical Dimensions

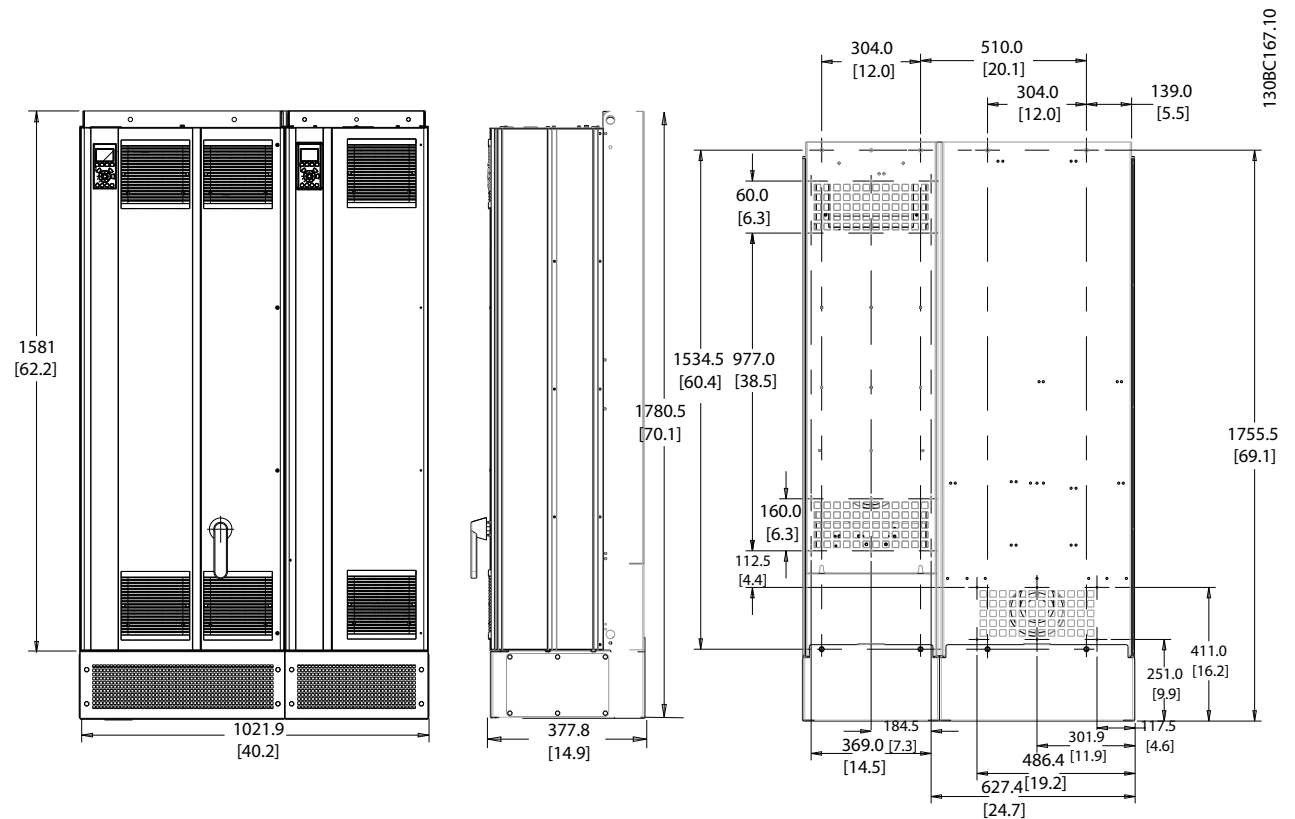

Illustration 8.2 Frame Size D13

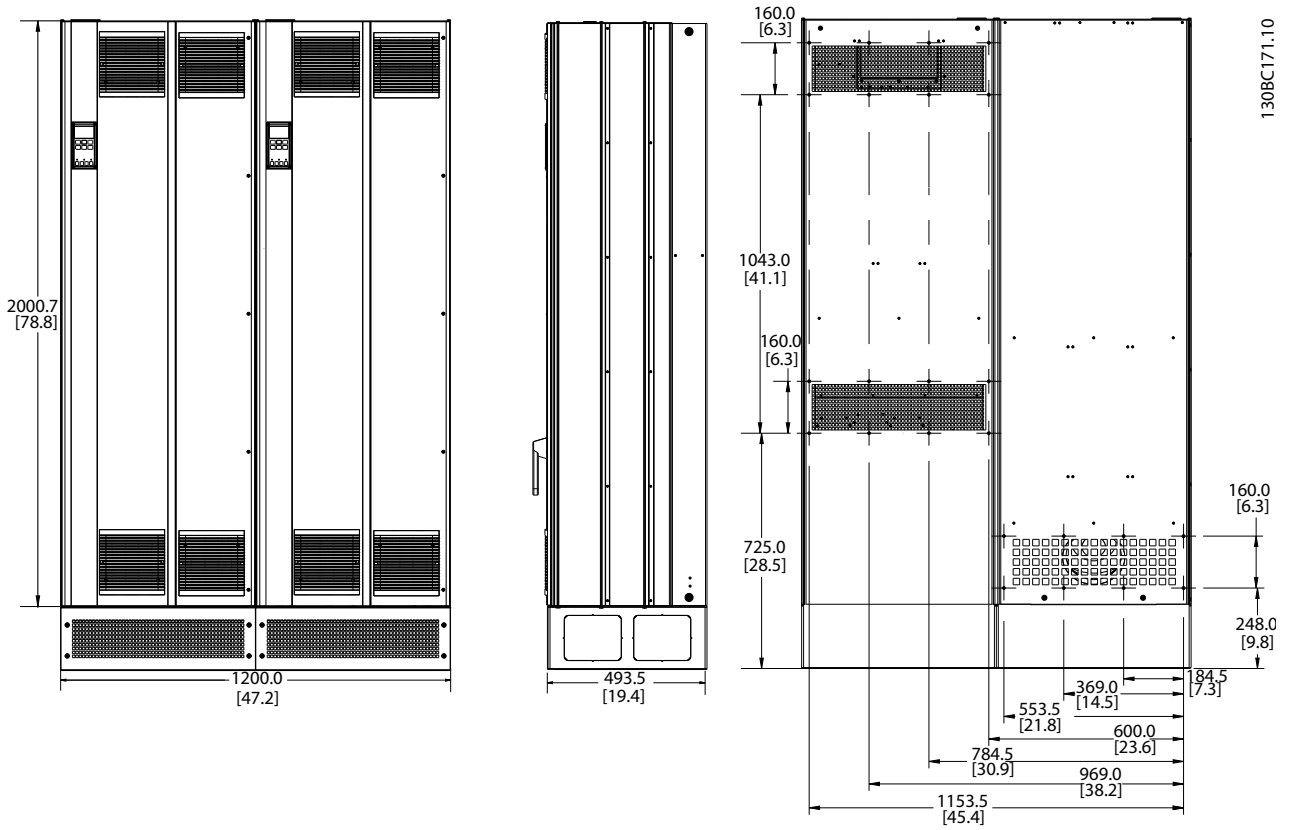

Illustration 8.3 Frame Size E9

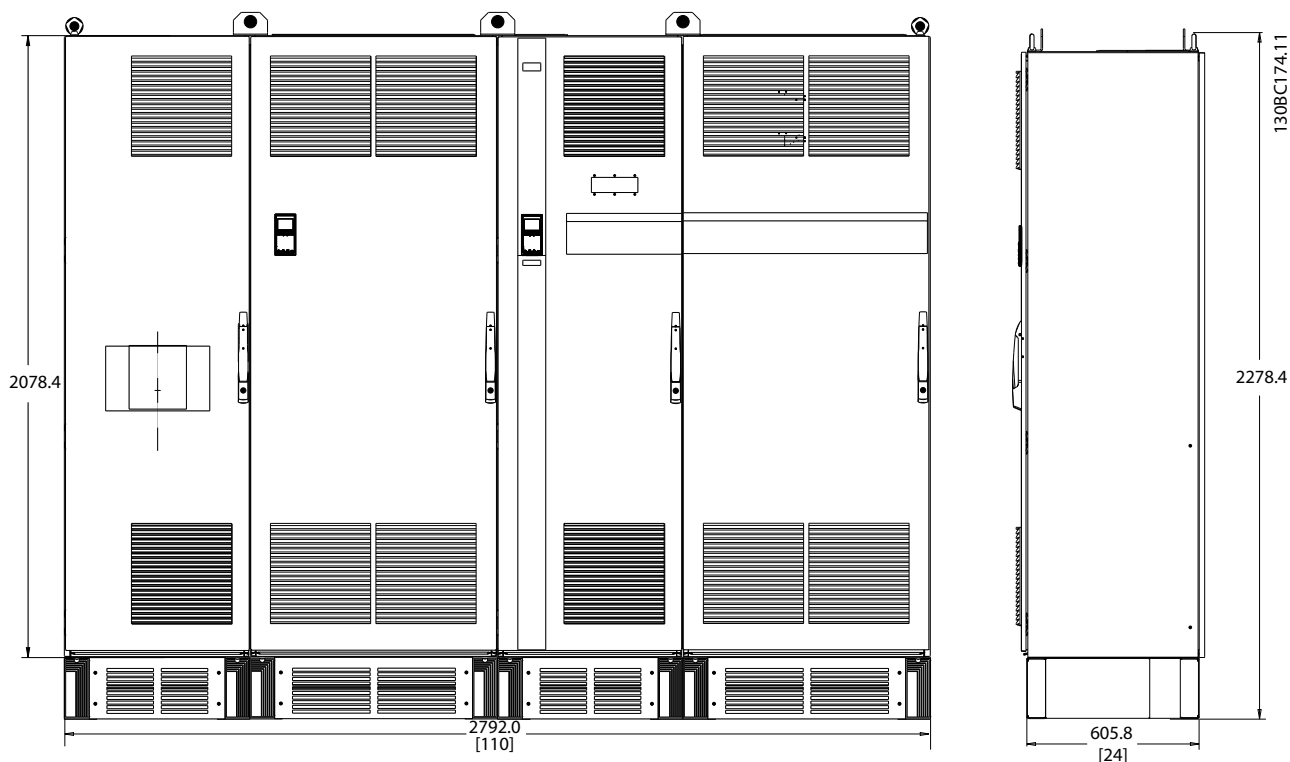

Illustration 8.4 Frame Size F18, Front and Side View

8.3 General Technical Data - Frequency Converter

Mains supply (L1, L2, L3)

Supply voltage 380–480 V +5%

Mains voltage low/mains drop-out:

During low mains voltage or mains drop-out, the frequency converter continues until the intermediate circuit voltage drops below the minimum stop level, corresponding to 15% below the lowest rated supply voltage. Power up and full torque cannot be expected at mains voltage lower than 10% below the lowest rated supply voltage.

Supply frequency 50/60 Hz ±5%

Max. imbalance temporary between mains phases 3.0% of rated supply voltage

True power factor (λ) > 0.98 nominal at rated load

Displacement power factor (cosφ) near unity (> 0.98)

THiD < 5%

Switching on input supply L1, L2, L3 (power-ups) maximum once/2 min.

Environment according to EN60664-1 overvoltage category III/pollution degree 2

The unit is suitable for use on a circuit capable of delivering not more than 100.000 RMS symmetrical Amperes, 480/690 V maximum.

Motor output (U, V, W)

Output voltage 0-100% of supply voltage

Output frequency 0-590 Hz¹⁾

Switching on output Unlimited

Ramp times 0.01-3600 s

1) Voltage and power dependent

Torque characteristics

Starting torque (constant torque)	maximum 160% for 1 m ¹⁾
Starting torque	maximum 180% up to 0.5 s ¹⁾
Overload torque (constant torque)	maximum 160% for 1 m ¹⁾

1) Percentage relates to nominal torque of the unit.

Cable lengths and cross-sections

Max. motor cable length, screened/armoured	150 m
Max. motor cable length, unscreened/unarmoured	300 m
Max. cross-section to motor, mains, load sharing, and brake ¹⁾	
Maximum cross-section to control terminals, rigid wire	1.5 mm ² /16 AWG (2 x 0.75 mm ²)
Maximum cross-section to control terminals, flexible cable	1 mm ² /18 AWG
Maximum cross-section to control terminals, cable with enclosed core	0.5 mm ² /20 AWG
Minimum cross-section to control terminals	0.25 mm ²

1) See chapter 8.1.1 Mains Supply 3x380-480 V AC for more information

Digital inputs

Programmable digital inputs	4 (6)
Terminal number	18, 19, 27 ¹⁾ , 29 ¹⁾ , 32, 33,
Logic	PNP or NPN
Voltage level	0-24 V DC
Voltage level, logic '0' PNP	< 5 V DC
Voltage level, logic '1' PNP	> 10 V DC
Voltage level, logic '0' NPN	> 19 V DC
Voltage level, logic '1' NPN	< 14 V DC
Maximum voltage on input	28 V DC
Input resistance, R _i	approx. 4 kΩ

All digital inputs are galvanically isolated from the supply voltage (PELV) and other high-voltage terminals.

1) Terminals 27 and 29 can also be programmed as output.

Analog inputs

Number of analog inputs	2
Terminal number	53, 54
Modes	Voltage or current
Mode select	Switch S201 and switch S202
Voltage mode	Switch S201/switch S202 = OFF (U)
Voltage level	0 to + 10 V (scaleable)
Input resistance, R _i	approx. 10 kΩ
Max. voltage	± 20 V
Current mode	Switch S201/switch S202 = ON (I)
Current level	0/4 to 20 mA (scaleable)
Input resistance, R _i	approx. 200 Ω
Max. current	30 mA
Resolution for analog inputs	10 bit (+ sign)
Accuracy of analog inputs	Max. error 0.5% of full scale
Bandwidth	200 Hz

The analog inputs are galvanically isolated from the supply voltage (PELV) and other high-voltage terminals.

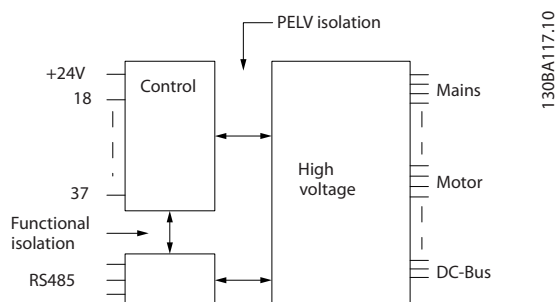

Illustration 8.5 PELV Isolation of Analog Inputs

Pulse inputs

Programmable pulse inputs	2
Terminal number pulse	29, 33
Max. frequency at terminal, 29, 33	110 kHz (Push-pull driven)
Max. frequency at terminal, 29, 33	5 kHz (open collector)
Min. frequency at terminal 29, 33	4 Hz
Voltage level	see chapter 8.3.1 Digital inputs
Maximum voltage on input	28 V DC
Input resistance, R_i	approx. 4 k Ω
Pulse input accuracy (0.1–1 kHz)	Max. error: 0.1% of full scale

Analog output

Number of programmable analog outputs	1
Terminal number	42
Current range at analog output	0/4-20 mA
Max. resistor load to common at analog output	500 Ω
Accuracy on analog output	Max. error: 0.8% of full scale
Resolution on analog output	8 bit

The analog output is galvanically isolated from the supply voltage (PELV) and other high-voltage terminals.

Control card, RS-485 serial communication

Terminal number	68 (P,TX+, RX+), 69 (N,TX-, RX-)
Terminal number 61	Common for terminals 68 and 69

The RS-485 serial communication circuit is functionally seated from other central circuits and galvanically isolated from the supply voltage (PELV).

Digital output

Programmable digital/pulse outputs	2
Terminal number	27, 29 ¹⁾
Voltage level at digital/frequency output	0-24 V
Max. output current (sink or source)	40 mA
Max. load at frequency output	1 k Ω
Max. capacitive load at frequency output	10 nF
Minimum output frequency at frequency output	0 Hz
Maximum output frequency at frequency output	32 kHz
Accuracy of frequency output	Max. error: 0.1% of full scale
Resolution of frequency outputs	12 bit

1) Terminal 27 and 29 can also be programmed as input.

The digital output is galvanically isolated from the supply voltage (PELV) and other high-voltage terminals.

Control card, 24 V DC output

Terminal number	13
Output voltage	24 V (+1, -3 v)
Max. load	200 mA

The 24 V DC supply is galvanically isolated from the supply voltage (PELV), but has the same potential as the analog and digital inputs and outputs.

Relay outputs

Programmable relay outputs	2
Relay 01 Terminal number	1-3 (break), 1-2 (make)
Max. terminal load (AC-1) ¹⁾ on 1-3 (NC), 1-2 (NO) (resistive load)	240 V AC, 2 A
Max. terminal load (AC-15) ¹⁾ (inductive load @ cosφ 0.4)	240 V AC, 0.2 A
Max. terminal load (DC-1) ¹⁾ on 1-2 (NO), 1-3 (NC) (resistive load)	60 V DC, 1 A
Max. terminal load (DC-13) ¹⁾ (inductive load)	24 V DC, 0.1 A
Relay 02 Terminal number	4-6 (break), 4-5 (make)
Max. terminal load (AC-1) ¹⁾ on 4-5 (NO) (resistive load) ²⁾³⁾	400 V AC, 2 A
Max. terminal load (AC-15) ¹⁾ on 4-5 (NO) (inductive load @ cosφ 0.4)	240 V AC, 0.2 A
Max. terminal load (DC-1) ¹⁾ on 4-5 (NO) (resistive load)	80 V DC, 2 A
Max. terminal load (DC-13) ¹⁾ on 4-5 (NO) (inductive load)	24 V DC, 0.1 A
Max. terminal load (AC-1) ¹⁾ on 4-6 (NC) (resistive load)	240 V AC, 2 A
Max. terminal load (AC-15) ¹⁾ on 4-6 (NC) (inductive load @ cosφ 0.4)	240 V AC, 0.2 A
Max. terminal load (DC-1) ¹⁾ on 4-6 (NC) (resistive load)	50 V DC, 2 A
Max. terminal load (DC-13) ¹⁾ on 4-6 (NC) (inductive load)	24 V DC, 0.1 A
Min. terminal load on 1-3 (NC), 1-2 (NO), 4-6 (NC), 4-5 (NO)	24 V DC 10 mA, 24 V AC 20 mA
Environment according to EN 60664-1	overvoltage category III/pollution degree 2

1) IEC 60947 parts 4 and 5

The relay contacts are galvanically isolated from the rest of the circuit by reinforced isolation (PELV).

2) Overvoltage Category II

3) UL applications 300 V AC 2 A

Control characteristics

Resolution of output frequency at 0-1000 Hz	±0.003 Hz
System response time (terminals 18, 19, 27, 29, 32, 33)	≤ 2 ms
Speed control range (open loop)	1:100 of synchronous speed
Speed accuracy (open loop)	30-4000 RPM: Maximum error of ±8 RPM

All control characteristics are based on a 4-pole asynchronous motor

Surroundings

Enclosure, frame size D and E	IP21, IP54
Enclosure, frame size F	IP21, IP54
Vibration test	0.7 g
Relative humidity	5-95% (IEC 721-3-3; Class 3K3 (non-condensing) during operation
Aggressive environment (IEC 60068-2-43) H ₂ S test	class kD
Test method according to IEC 60068-2-43 H ₂ S (10 days)	
Ambient temperature (at 60 AVM switching mode)	
- with derating	max. 55 °C
- with full output power, typical IE2 motors (see chapter 8.1.2 Derating for Temperature)	max. 50 °C
- at full continuous FC output current	max. 45 °C
Minimum ambient temperature during full-scale operation	0 °C
Minimum ambient temperature at reduced performance	- 10 °C
Temperature during storage/transport	-25 - +65/70 °C
Maximum altitude above sea level without derating	1,000 m
Maximum altitude above sea level with derating	3,000 m

For more information on derating, consult the design guide

EMC standards, emission	EN 61800-3, EN 61000-6-3/4, EN 55011, IEC 61800-3
-------------------------	---

EMC standards, immunity	EN 61800-3, EN 61000-6-1/2, EN 61000-4-2, EN 61000-4-3, EN 61000-4-4, EN 61000-4-5, EN 61000-4-6
Control card performance	
Scan interval	5 ms
Control card, USB serial communication	
USB standard	1.1 (full speed)
USB plug	USB type B device plug

NOTICE

Connection to PC is carried out via a standard host/device USB cable.
 The USB connection is galvanically isolated from the supply voltage (PELV) and other high-voltage terminals.
 The USB connection is not galvanically isolated from protective earth. Use only isolated laptop/PC as connection to the USB connector on the frequency converter or an isolated USB cable/converter.

Protection and features:

- Electronic thermal motor protection against overload.
- Temperature monitoring of the heat sink ensures that the frequency converter trips if the temperature reaches a predefined level. An overload temperature cannot be reset until the temperature of the heat sink is below the allowed values.
- The frequency converter is protected against short-circuits on motor terminals U, V, W.
- If a mains phase is missing, the frequency converter trips or issues a warning (depending on the load).
- Monitoring of the intermediate circuit voltage ensures that the frequency converter trips if the intermediate circuit voltage is too low or too high.
- The frequency converter is protected against earth faults on motor terminals U, V, W.



8.4 General Technical Data - Filter

Response time [ms]	<0.5
Settling time - reactive current control [ms]	<40
Settling time - harmonic current control (filtering) [ms]	<20
Overshoot - reactive current control [%]	<20
Overshoot - harmonic current control [%]	<10

Table 8.4 Power Ranges (LHD with AF)

8.4.1 Power Rating

Grid conditions

Supply voltage	380-480 V, +5%/-10%
----------------	---------------------

Mains voltage low/mains drop-out:

During low mains voltage or a mains drop-out, the filter continues until the intermediate circuit voltage drops below the minimum stop level, which corresponds to 15% below the filter lowest rated supply voltage. Full compensation cannot be expected at mains voltage lower than 10% below the filter lowest rated supply voltage. If mains voltage exceed the filter highest rated voltage, the filter continues to work but harmonic mitigation performance is reduced. The filter does not cut out until main voltages exceed 580 V.

Supply frequency	50/60 Hz ±5%
Max. imbalance temporary between mains phases where mitigation performance is kept high.	3.0% of rated supply voltage Filter mitigates at higher mains imbalance but harmonic mitigation performance is reduced

Max THDv pre-distortion	10% with kept mitigation performance Reduced performance for higher pre-distortion levels
-------------------------	--

Harmonic mitigation performance

	Best performance <4%
THiD	Depending on filter vs. distortion ratio.
Individual harmonic mitigation ability:	Current maximum RMS [% of rated RMS current]
2nd	10%
4th	10%
5th	70%
7th	50%
8th	10%
10th	5%
11th	32%
13th	28%
14th	4%
16th	4%
17th	20%
19th	18%
20th	3%
22nd	3%
23rd	16%
25th	14%
Total current of harmonics	90%

The filter is performance tested to the 40th order

Reactive current compensation

Cos phi	Controllable 1.0 to 0.5 lagging
Reactive current, % of filter current rating	100%

Cable lengths and cross-sections

Max grid cable length (direct internal connection to drive)	Unlimited (determined by voltage drop)
Maximum cross-section to control terminals, rigid wire	1.5 mm ² /16 AWG (2 x 0.75 mm ²)
Maximum cross-section to control terminals, flexible cable	1 mm ² /18 AWG
Maximum cross-section to control terminals, cable with enclosed core	0.5 mm ² /20 AWG
Minimum cross-section to control terminals	0.25 mm ²

CT terminals specification

CT number	3 (one for each phase)
The AAF burden equals	2 mΩ
Secondary current rating	1 A or 5 A (hardware set-up)
Accuracy	Class 0.5 or better

Digital inputs

Programmable digital inputs	2 (4)
Terminal number	18, 19, 27 ¹⁾ , 29 ¹⁾
Logic	PNP or NPN
Voltage level	0-24-V DC
Voltage level, logic '0' PNP	< 5 V DC
Voltage level, logic '1' PNP	> 10 V DC
Voltage level, logic '0' NPN	> 19 V DC
Voltage level, logic '1' NPN	< 14 V DC
Maximum voltage on input	28 V DC
Input resistance, R _i	approx. 4 kΩ

All digital inputs are galvanically isolated from the supply voltage (PELV) and other high-voltage terminals.

1) Terminals 27 and 29 can also be programmed as output.

Control card, RS-485 serial communication

Terminal number	68 (P, TX+, RX+), 69 (N, TX-, RX-)
Terminal number 61	Common for terminals 68 and 69

The RS-485 serial communication circuit is functionally separated from other central circuits and galvanically isolated from the supply voltage (PELV).

Digital output

Programmable digital/pulse outputs	2
Terminal number	27, 29 ¹⁾
Voltage level at digital/frequency output	0–24 V
Max. output current (sink or source)	40 mA

1) Terminal 27 and 29 can also be programmed as input.

Control card, 24 V DC output

Terminal number	13
Max. load	200 mA

The 24 V DC supply is galvanically isolated from the supply voltage (PELV), but has the same potential as the analog and digital inputs and outputs.

Surroundings

Enclosure	IP21, IP54
Vibration test	1.0 g
Relative humidity	5% - 95% (IEC 721-3-3; class 3K3 (non-condensing) during operation
Aggressive environment (IEC 60068-2-43) H ₂ S test	class kD
Test method according to IEC 60068-2-43 H ₂ S (10 days)	
Ambient temperature	
- with derating	maximum 50 °C
- at full continuous output current	max. 40 °C
Minimum ambient temperature	-10 °C
Temperature during storage/transport	-25 to +65 °C
Maximum altitude above sea level without derating	1000 m
Maximum altitude above sea level with derating	3000 m
EMC standards, Emission	EN 61800-3, EN 61000-6-3/4, EN 55011, IEC 61800-3 EN 61800-3, EN 61000-6-1/2,
EMC standards, Immunity	EN 61000-4-2, EN 61000-4-3, EN 61000-4-4, EN 61000-4-5, EN 61000-4-6

Control card performance

Scan interval	5 ms
---------------	------

Control card, USB serial communication

USB standard	1.1 (full speed)
USB plug	USB type B "device" plug

Generic specifications

Maximum parallel filters	4 on same CT set
Filter efficiency	97%
Typical average switching frequency	3.0–4.5 kHz
Response time (reactive and harmonic)	< 0.5 ms
Settling time - reactive current control	< 20 ms
Settling time - harmonic current control	< 20 ms
Overshoot – reactive current control	<10%
Overshoot – Harmonic current control	<10%

Connection to PC is carried out via a standard host/device USB cable. The USB connection is galvanically isolated from the supply voltage (PELV) and other high-voltage terminals. The USB connection is not galvanically isolated from protective earth. Use only isolated laptop/PC as connection to the USB connector on the unit or an isolated USB cable/converter.

Protection and features

- Temperature monitoring of the heat sink ensures that the active filter trips if the temperature reaches a predefined level. An overload temperature cannot be reset until the temperature of the heat sink is below the acceptable values.
- If a mains phase is missing, the active filter trips.
- The active filter has a short circuit protection current rate of 100 kA if properly fused
- Monitoring of the intermediate circuit voltage ensures that the filter trips if the intermediate circuit voltage is too low or too high.
- The active filter monitors the mains current as well as internal currents to reassure that current levels do not reach critical levels. If current exceeds a critical level, the filter trips.

8.4.2 Derating for Altitude

The cooling capability of air is decreased at lower air pressure.

Below 1000 m altitude no derating is necessary but above 1000 m the ambient temperature (T_{AMB}) or max. output current (I_{out}) should be derated in accordance with *Illustration 8.6*.

An alternative is to lower the ambient temperature at high altitudes and thereby ensure 100% output current at high altitudes. As an example of how to read the graph, the situation at 2,000 m is elaborated. At a temperature of 45 °C ($T_{AMB, MAX} - 3.3 K$), 91% of the rated output current is available. At a temperature of 41.7 °C, 100% of the rated output current is available.

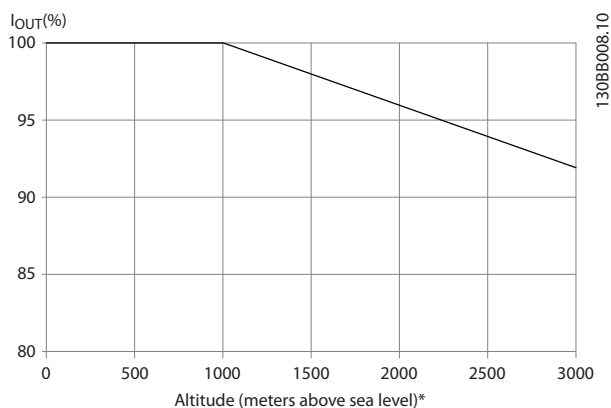

Illustration 8.6 Altitude Derating

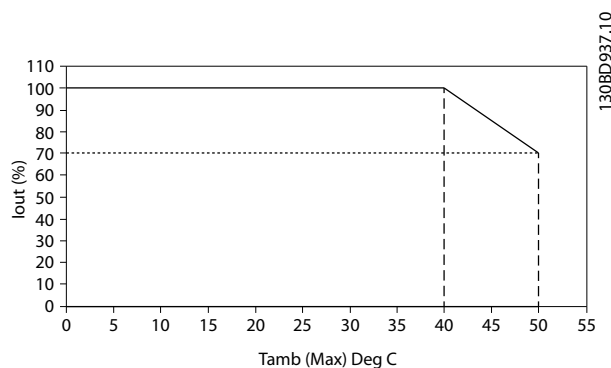

Illustration 8.7 Input/Output vs. Maximum Ambient Temperature

8.5 Fuses

8.5.1 Fuses

Use fuses and/or circuit breakers on the supply side as protection in case of component break-down inside the frequency converter (first fault).

NOTICE

Using fuses and/or circuit breakers is mandatory to ensure compliance with IEC 60364 for CE or NEC 2009 for UL.

WARNING

Protect personnel and property against the consequence of component break-down internally in the frequency converter.

Branch circuit protection

To protect the installation against electrical and fire hazard, protect all branch circuits in an installation, switch gear, machines etc. against short circuit and overcurrent according to national/international regulations.

NOTICE

The recommendations do not cover branch circuit protection for UL.

Short-circuit protection

Danfoss recommends using the fuses/circuit breakers mentioned in this section to protect service personnel and property in case of component breakdown in the frequency converter.

Overcurrent protection

The frequency converter provides overload protection to limit threats to human life, property damage and to avoid fire hazard due to overheating of the cables. The frequency converter is equipped with an internal overcurrent protection (*parameter4-18 Current Limit*) that can be used for upstream overload protection (UL applications excluded). Moreover, fuses or circuit breakers can be used to provide the overcurrent protection in the installation. Overcurrent protection must always be carried out according to national regulations.

The tables in this section list the recommended rated current. Recommended fuses are of the type gG for small to medium power sizes. For larger powers, aR fuses are recommended. Use circuit breakers that meet the national/international regulations and that limit the energy into the frequency converter to an equal or lower level than the compliant circuit breakers.

If fuses/circuit breakers are selected according to recommendations, possible damage on the frequency converter is mainly limited to damage inside the unit.

P160-P250	380-480 V	type gG
P315-P450	380-480 V	type gR

Table 8.5 Fuse Types by Power Range

Non UL compliance

If UL/cUL is not to be complied with, use the following fuses, which ensure compliance with EN50178:

8.5.2 Fuse Specifications

UL compliance

380-480 V, frame sizes D, E and F

The fuses below are suitable for use on a circuit capable of delivering 100,000 A_{rms} (symmetrical), 240 V, or 480 V, or 500 V, or 600 V depending on the frequency converter voltage rating. With the proper fusing the frequency converter Short Circuit Current Rating (SCCR) is 100,000 A_{rms}.

Size/Type	Bussmann E1958 JFHR2 ²⁾	Bussmann E4273 T/JDDZ ²⁾	SIBA E180276 JFHR2	LittelFuse E91611 JFHR2 ²⁾	Ferraz-Shawmut E60314 JFHR2 ²⁾	Bussmann E4274 H/JDDZ ²⁾	Bussmann E125085 JFHR2 ¹⁾	Internal Option Bussmann
P160	FWH-400	JJS-400	2061032.40	L50S-400	A50-P400	NOS-400	170M4012	170M4016
P200	FWH-500	JJS-500	2061032.50	L50S-500	A50-P500	NOS-500	170M4014	170M4016
P250	FWH-600	JJS-600	2062032.63	L50S-600	A50-P600	NOS-600	170M4016	170M4016

Table 8.6 Frame size D, Line Fuses, 380-480 V

Size/Type	Bussmann PN ¹⁾	Rating	Ferraz	Siba
P315	170M4017	700 A, 700 V	6.9URD31D08A0700	20 610 32.700
P355	170M6013	900 A, 700 V	6.9URD33D08A0900	20 630 32.900
P400	170M6013	900 A, 700 V	6.9URD33D08A0900	20 630 32.900
P450	170M6013	900 A, 700 V	6.9URD33D08A0900	20 630 32.900

Table 8.7 Frame size E, Line Fuses, 380-480 V

Size/Type	Bussmann PN ¹⁾	Rating	Siba	Internal Bussmann Option
P500	170M7081	1600 A, 700 V	20 695 32.1600	170M7082
P560	170M7081	1600 A, 700 V	20 695 32.1600	170M7082
P630	170M7082	2000 A, 700 V	20 695 32.2000	170M7082
P710	170M7082	2000 A, 700 V	20 695 32.2000	170M7082

Table 8.8 Frame size F, Line Fuses, 380-480 V

Size/Type	Bussmann PN ¹⁾	Rating	Siba
P500	170M8611	1100 A, 1000 V	20 781 32.1000
P560	170M8611	1100 A, 1000 V	20 781 32.1000
P630	170M6467	1400 A, 700 V	20 681 32.1400
P710	170M6467	1400 A, 700 V	20 681 32.1400

Table 8.9 Frame Size F, Inverter module DC Link Fuses, 380-480 V

1) 170M fuses from Bussmann shown use the -/80 visual indicator, -TN/80 Type T, -/110 or TN/110 Type T indicator fuses of the same size and amperage may be substituted for external use

2) Any minimum 500 V UL listed fuse with associated current rating may be used to meet UL requirements.

Supplementary fuses

Frame size	Bussmann PN ¹⁾	Rating
D, E and F	KTK-4	4 A, 600 V

Table 8.10 SMPS Fuse

Size/Type	Bussmann PN ¹⁾	Littelfuse	Rating
P160-P315, 380-480 V	KTK-4		4 A, 600 V
P355-P710, 380-480 V		KLK-15	15A, 600 V

Table 8.11 Fan Fuses

Size/Type		Bussmann PN ¹⁾	Rating	Alternative Fuses
P500-P710, 380-480 V	2.5-4.0 A	LPJ-6 SP or SPI	6 A, 600 V	Any listed Class J Dual Element, Time Delay, 6A
P500-P710, 380-480 V	4.0-6.3 A	LPJ-10 SP or SPI	10 A, 600 V	Any listed Class J Dual Element, Time Delay, 10 A
P500-P710, 380-480 V	6.3-10 A	LPJ-15 SP or SPI	15 A, 600 V	Any listed Class J Dual Element, Time Delay, 15 A
P500-P710, 380-480 V	10-16 A	LPJ-25 SP or SPI	25 A, 600 V	Any listed Class J Dual Element, Time Delay, 25 A

Table 8.12 Manual Motor Controller Fuses

Frame size	Bussmann PN ¹⁾	Rating	Alternative Fuses
F	LPJ-30 SP or SPI	30 A, 600 V	Any listed Class J Dual Element, Time Delay, 30 A

Table 8.13 30 A Fuse Protected Terminal Fuse

Frame size	Bussmann PN ¹⁾	Rating	Alternative Fuses
D	LP-CC-8/10	0.8A, 600V	Any listed Class CC, 0.8A
E	LP-CC-1 1/2	1.5A, 600V	Any listed Class CC, 1.5A
F	LPJ-6 SP or SPI	6 A, 600 V	Any listed Class J Dual Element, Time Delay, 6 A

Table 8.14 Control Transformer Fuse

Frame size	Bussmann PN ¹⁾	Rating
F	GMC-800MA	800 mA, 250 V

Table 8.15 NAMUR Fuse

Frame size	Bussmann PN ¹⁾	Rating	Alternative Fuses
F	LP-CC-6	6 A, 600 V	Any listed Class CC, 6 A

Table 8.16 Safety Relay Coil Fuse with PILZ Relay

1) 170M fuses from Bussmann shown use the -/80 visual indicator, -TN/80 Type T, -/110 or TN/110 Type T indicator fuses of the same size and amperage may be substituted for external use

9 Appendix

9.1 Abbreviations and Conventions

AC	Alternating Current
AEO	Automatic Energy Optimization
AMA	Automatic Motor Adaptation
AWG	American Wire Gauge
°C	Degrees Celsius
DC	Direct Current
EMC	Electromagnetic Compatibility
ETR	Electronic Thermal Relay
$f_{M,N}$	Nominal Motor Frequency
FC	Frequency Converter
I_{LIM}	Current Limit
I_{INV}	Rated Inverter Output Current
$I_{M,N}$	Nominal Motor Current
$I_{VLT,MAX}$	The Maximum Output Current
$I_{VLT,N}$	The Rated Output Current Supplied by the Frequency Converter
IP	Ingress Protection
LCP	Local Control Panel
N.A.	Not applicable
$P_{M,N}$	Nominal Motor Power
PCB	Printed Circuit Board
PE	Protective earth
PELV	Protective Extra Low Voltage
Regen	Regenerative Terminals
RPM	Revolutions Per Minute
T_{LIM}	Torque Limit
$U_{M,N}$	Nominal Motor Voltage

Table 9.1 Abbreviations

Conventions

Numbered lists indicate procedures.

Bullet lists indicate other information and description of illustrations.

Italicised text indicates

- cross reference
- link
- footnote
- parameter name, parameter group name, parameter option

Index

A

Abbreviation..... 90

AC mains..... 15

Active filter..... 4

Additional literature..... 4

ADN compliance..... 14

Airflow..... 17

Alarm log..... 46

Alarm/warning code list..... 67

AMA..... 41, 56, 60, 64

AMA, successful..... 42

AMA, unsuccessful..... 42

Analog input..... 59, 80

Analog output..... 81

Analog signal..... 59

Analog speed reference..... 52

Anchoring..... 19

Approval..... 14

Auto on..... 46, 51

Auto On..... 56, 57

Auto remote coasting..... 45

Automatic Energy Optimisation..... 50

Automatic motor adaptation..... 50

Automatic Motor Adaptation (AMA)..... 41

Auto-reset..... 45

B

Back cooling..... 17

Bottom view..... 19

Brake

 control..... 60

 resistor..... 59

Brake cable..... 32

Brake chopper..... 32

Brake resistor temperature switch..... 32

Braking..... 56, 61

Branch circuit protection..... 87

C

Cable length, cross-section..... 80, 84

Cable size, maximum..... 74, 75, 76

Cable-length, cross-section..... 30

Cabling..... 29

CE compliance mark..... 14

Circuit breaker..... 44

Communication option..... 62

Compliance mark, CE..... 14

Conduit..... 43

Control card

 Control card..... 59

Control card performance..... 83

Control card, 24 V DC output..... 82

Control card, RS-485 serial communication..... 81

Control card, USB serial communication..... 83, 85

Control characteristic..... 82

Control signal..... 56

Control system..... 4

Control terminal..... 36, 46, 48, 56, 58

Control terminals, access..... 36

Control wiring..... 43

Convention..... 90

Cooling..... 17

Cooling clearance..... 43

CT terminal, specification..... 84

Current rating..... 16, 60

D

DC current..... 28, 56

DC link..... 59, 70

Default setting..... 47

Definition..... 4

Delta..... 41

Derating, altitude..... 87

Digital input..... 57, 60, 80

Digital output..... 81

Dimension..... 14

Dimension, mechanical..... 77

Discharge time..... 15

Disconnect switch..... 43, 45

Distortion..... 4

Download manual..... 4

E

ELCB relay..... 31

Electrical installation..... 36

Electromechanical brake..... 39

EMC..... 28, 43

Enclosure..... 14, 74, 75, 76

Exploded view..... 6

External alarm reset..... 54

External command..... 58

External fan supply..... 33

F

Factory installed brake chopper option..... 32

Fan..... 33

Fault log..... 46

Fault message, active filter..... 70

Feedback..... 43, 56, 63

F-frame option..... 39

Fieldbus connection..... 35

Filter capacitor..... 31

Final set-up and test..... 41

Full load current..... 16

Fuse..... 28, 43, 62, 72, 87

Fuse specification..... 88

Fusing..... 43

G

Grid condition..... 83

Ground connection..... 43

Ground wire..... 43

Grounding..... 30, 31, 43

H

Hand..... 56

Hand on..... 46

Hand On..... 56

Harmonic mitigation performance..... 84

Harmonics..... 4

Heat sink..... 63

Heater..... 39

High voltage..... 43

I

IEC emergency stop, Pilz safety relay..... 40

Initialisation..... 47

Input current, maximum..... 74, 75, 76

Input power..... 15, 43, 58, 72

Input terminal..... 43, 59

Input voltage..... 45, 58

Installation..... 43, 45

Installation site, planning..... 16

Insulation Resistance Monitor (IRM)..... 40

Intermediate circuit..... 59

IT main..... 31

L

Lifting..... 18

Local control..... 45, 46, 56

Local control panel (LCP)..... 45

M

Main menu..... 46

Mains connection..... 33

Mains input..... 24

Mains supply (L1, L2, L3)..... 79

Mains voltage..... 45, 56

Manual initialisation..... 47

Manual motor starter..... 40

Maximum cable size..... 74, 75, 76

Maximum input current..... 74, 75, 76

MCT 10..... 45

Mechanical brake control..... 39

Mechanical dimension..... 77

Menu key..... 45, 46

Menu structure..... 46

Motor

- current..... 64
- data..... 60, 64
- power..... 64
- thermistor..... 55
- Thermistor..... 55

Motor cable..... 28, 31

Motor current..... 45, 50

Motor data..... 48, 50

Motor insulation..... 32

Motor name plate..... 41

Motor output..... 79

Motor power..... 45

Motor protection..... 83

Motor rotation..... 51

Motor rotation check..... 31

Motor speed..... 48

Motor thermal protection..... 33, 55

Motor wiring..... 43

Mounting..... 43

Multiple frequency converter..... 28

N

Nameplate..... 16

NAMUR..... 40

Navigation key..... 45, 46, 48, 56

NDE bearing..... 32
 Noise isolation..... 43
 Non UL compliance..... 88
 Normal overload..... 74, 75, 76

O

Operation key..... 45
 Optional equipment..... 4, 45
 Output current..... 16, 56, 60, 74, 75, 76
 Output performance (U, V, W)..... 79
 Output terminal..... 43
 Overcurrent..... 57
 Overcurrent protection..... 28
 Overload protection..... 16
 Overvoltage..... 57

P

Parallel connection, motor..... 39
 PELV..... 55
 Phase loss..... 59
 Power connection..... 28, 29
 Power factor..... 43
 Power rating..... 14
 Power, input..... 58
 Programming..... 45, 46, 59
 Protection, feature..... 83
 Pulse input..... 81
 Pulse start/stop..... 54

Q

Qualified personnel..... 15
 Quick menu..... 45, 46

R

RCD..... 31
 RCD (Residual Current Device)..... 40
 Reactive current compensation..... 84
 Reference..... 45, 52, 56, 57
 Relay output..... 82
 Remote reference..... 57
 Reset..... 45, 46, 47, 58, 60, 64, 65
 RFI capacitor..... 31
 RFI switch..... 31
 RS-485..... 55
 Run command..... 51
 Run permissive..... 57

S

Screened/armoured..... 34
 Screened/armoured cable..... 34
 Screening, cable..... 30
 Serial communication..... 46, 56, 57, 58, 83
 Setpoint..... 57
 Set-up..... 46, 51
 Shielded cable..... 31, 43
 Shipping damage..... 16
 Short circuit..... 61
 Sleep mode..... 57
 SmartStart..... 47
 Speed reference..... 51, 52, 56
 Speed reference, analog..... 52
 Start/stop command..... 53
 Start-up..... 47, 72
 Status display..... 56
 Status mode..... 56
 Stop command..... 57
 Supply voltage..... 43, 62
 Surrounding..... 82
 Switching frequency..... 30, 57

T

Temperature limit..... 43
 Terminal function..... 33
 Terminal location..... 22
 Thermal motor protection..... 60
 Thermistor..... 60
 Torque..... 26, 60
 Torque characteristic..... 80
 Torque, terminal..... 27
 Trip..... 55

V

Voltage imbalance..... 59
 Voltage level..... 80, 84
 Voltage, input..... 58
 VVC+..... 50

W

Wire size..... 28
 Working principle..... 4



www.danfoss.com/drives

.....
Danfoss can accept no responsibility for possible errors in catalogues, brochures and other printed material. Danfoss reserves the right to alter its products without notice. This also applies to products already on order provided that such alterations can be made without subsequential changes being necessary in specifications already agreed. All trademarks in this material are property of the respective companies. Danfoss and the Danfoss logotype are trademarks of Danfoss A/S. All rights reserved.
.....

Danfoss A/S
Ulsnaes 1
DK-6300 Graasten
www.danfoss.com/drives

