



Contents

1 How to Read these Operating Instructions	5
1.1.1 Legal Information	5
2 Safety	7
2.1.2 General Warning	7
2.1.3 Before Commencing Repair Work	8
2.1.4 Special Conditions	8
2.1.5 Avoid Unintended Start	8
2.1.6 Safe Stop Installation	8
2.1.7 Safe Stop of the Frequency Converter	10
2.1.8 IT Mains	11
3 Introduction to the Low Harmonic Drive	12
3.1.1 Working Principle	12
3.1.2 IEEE519 Compliance	12
3.1.3 Ordering Form Type Code	13
4 How to Install	14
4.1 How to Get Started	14
4.2 Pre-installation	14
4.2.1 Planning the Installation Site	14
4.2.2 Receiving the Frequency Converter	15
4.2.3 Transportation and Unpacking	15
4.2.4 Lifting	15
4.2.5 Mechanical Dimensions	17
4.3 Mechanical Installation	22
4.3.3 Terminal Locations - Frame Size D13	23
4.3.4 Terminal Locations - Frame Size E9	24
4.3.5 Terminal Locations -	26
4.3.6 Cooling and Airflow	29
4.4 Field Installation of Options	33
4.4.1 Installation of Mains Shield for Frequency Converters	33
4.5 Frame Size F Panel Options	33
4.6 Electrical Installation	33
4.6.1 Power Connections	33
4.6.2 Earthing	42
4.6.4 Drives with Factory installed A1/B1 RFI Filter Option	42
4.6.5 Torque	42
4.6.6 Shielded Cables	42
4.6.8 Load Sharing	43



4.6.9 Mains Connection	44
4.6.10 External Fan Supply	44
4.6.11 Power and Control Wiring for Unscreened Cables	44
4.6.12 Fuses	45
4.6.13 Fuse Specifications	45
4.6.16 Control Cable Routing	48
4.6.18 Electrical Installation, Control Terminals	48
4.7 Connection Examples for Control of Motor with External Signal Provider	49
4.7.1 Start/Stop	49
4.7.2 Pulse Start/Stop	49
4.8 Electrical Installation - Additional	51
4.8.1 Electrical Installation, Control Cables	51
4.8.2 Switches S201, S202, and S801	52
4.9 Final Set-up and Test	53
4.10 Additional Connections	54
5 How to Operate the Low Harmonic Drive	55
5.1.2 How to Operate Graphical LCP (GLCP)	55
6 How to Programme the Low Harmonic Drive	64
6.1 How to Programme the Frequency Converter	64
6.2 How to Programme the Active Filter	70
6.2.1 Using the Low Harmonic Drive in NPN Mode	71
6.3 Description of Common Parameters	72
6.3.1 Main Menu	72
6.4 Parameter Options	100
6.4.1 Default settings	100
6.4.2 0-** Operation/Display	101
6.4.3 1-** Load/Motor	103
6.4.4 2-** Brakes	105
6.4.5 3-** Reference/Ramps	106
6.4.6 4-** Limits/Warnings	107
6.4.7 5-** Digital In/Out	108
6.4.8 6-** Analog In/Out	110
6.4.9 8-** Comm. and Options	112
6.4.10 9-** Profibus	113
6.4.11 10-** CAN Fieldbus	114
6.4.12 13-** Smart Logic	115
6.4.13 14-** Special Functions	116
6.4.14 15-** FC Information	117
6.4.15 16-** Data Readouts	119



6.4.16 18-** Data Readouts 2	121
6.4.17 20-** FC Closed Loop	122
6.4.18 21-** Ext. Closed Loop	123
6.4.19 22-** Application Functions	125
6.4.20 23-** Timed Actions	127
6.4.21 25-** Cascade Controller	128
6.4.22 26-** Analog I/O Option MCB 109	130
6.4.24 29-** Water Application Functions	133
6.4.25 31-** Bypass Option	134
6.5 Parameter Options - Filter	134
6.5.1 0-** Operation/Display	134
6.5.2 5-** Digital In/Out	135
6.5.3 8-** Comm. and Options	135
6.5.4 14-** Special Functions	136
6.5.5 15-** FC Information	136
6.5.6 16-** Data Readouts	138
6.5.7 300-** AF Settings	139
6.5.8 301-** AF Readouts	140
7 RS-485 Installation and Set-up	141
7.1.2 EMC Precautions	142
7.2 Network Configuration	142
7.2.1 Set-up	142
7.3 Drive Protocol Message Framing Structure	142
7.3.1 Content of a Character (byte)	142
7.3.2 Telegram Structure	142
7.3.3 Telegram Length (LGE)	143
7.3.4 Frequency Converter Address (ADR)	143
7.3.5 Data Control Byte (BCC)	143
7.3.6 The Data Field	143
7.3.7 The PKE Field	144
7.3.8 Parameter Number (PNU)	145
7.3.9 Index (IND)	145
7.3.10 Parameter Value (PWE)	145
7.3.11 Data Types Supported by the Frequency Converter	146
7.3.12 Conversion	146
7.3.13 Process Words (PCD)	146
7.4 Examples	146
7.4.1 Writing a Parameter Value	147
7.4.2 Reading a Parameter Value	147
7.5 How to Access Parameters	148



7.5.1 Parameter Handling	148
7.5.2 Storage of Data	148
7.5.3 IND	148
7.5.4 Text Blocks	148
7.5.5 Conversion Factor	148
7.5.6 Parameter Values	148
8 General Specifications	149
8.2 Filter Specifications	156
9 Troubleshooting	157
9.1 Alarms and Warnings - Frequency Converter (Right LCP)	157
9.1.1 Warnings/Alarm Messages	157
9.2 Alarms and Warnings - Filter (Left LCP)	167
Index	173



1 How to Read these Operating Instructions

1.1.1 Legal Information

This publication contains information proprietary to Danfoss. By accepting and using this manual the user agrees that the information contained herein is used solely for operating equipment from Danfoss or equipment from other vendors if such equipment is intended for communication with Danfoss equipment over a serial communication link. This publication is protected under the Copyright laws of Denmark and most other countries.

Danfoss does not warrant that a software program produced according to the guidelines provided in this manual functions properly in every physical, hardware or software environment.

Although Danfoss has tested and reviewed the documentation within this manual, Danfoss makes no warranty or representation, neither expressed nor implied, with respect to this documentation, including its quality, performance, or fitness for a particular purpose.

In no event shall Danfoss be liable for direct, indirect, special, incidental, or consequential damages arising out of the use, or the inability to use information contained in this manual, even if advised of the possibility of such damages. In particular, Danfoss is not responsible for any costs, including but not limited to those incurred as a result of lost profits or revenue, loss or damage of equipment, loss of computer programs, loss of data, the costs to substitute these, or any claims by third parties.

Danfoss reserves the right to revise this publication at any time and to make changes to its contents without prior notice or any obligation to notify former or present users of such revisions or changes.

It has been assumed that all devices will be sitting behind a firewall that does packet filtering and the environment has well-implemented restrictions on the software that can run inside the firewall. All nodes are assumed to be "trusted" nodes.

1.1.2 Available Literature

- VLT® AQUA Drive Operating Instructions, MG20M provide the necessary information for getting the drive up and running.
- VLT® AQUA Drive High Power Operating Instructions, MG20P provide the necessary information for getting the HP drive up and running.
- VLT® AQUA Drive Design Guide, MG20N entails all technical information about the drive and customer design and applications.
- VLT® AQUA Drive Programming Guide, MN200 provides information on how to programme and includes complete parameter descriptions.
- VLT® AQUA Drive FC 200 Profibus, MG33C
- VLT® AQUA Drive FC 200 DeviceNet, MG33D
- Output Filters Design Guide MG90NXYY
- VLT® AQUA Drive FC 200 Cascade Controller, MI38C
- Application Note MN20A: Submersible Pump Application
- Application Note MN20: Master/Follower Operation Application
- Application Note MN20F: Drive Closed Loop and Sleep Mode
- Instruction MI38B: Installation Instruction for Mounting Brackets Enclosure type A5, B1, B2, C1 and C2 IP21, IP55 or IP66
- Instruction MI90L: Analog I/O Option MCB109
- Instruction MI33H: Panel through mount kit
- VLT® Active Filter Operating Instruction, MG90V

Danfoss technical literature is also available online at www.danfoss.com/BusinessAreas/DrivesSolutions/Documentations/Technical+Documentation.htm.

1.1.3 Software Version and Approvals

VLT® Automation VT Drive FC 322 Low Harmonic Drive

Software version: 1.84



This manual can be used with all VLT® Automation VT Drive FC 322 Low Harmonic Drive frequency converters with software version 1.84. The software version number can be found in *15-43 Software Version*.

Table 1.1

NOTE

The VLT® Automation VT Drive FC 322 Low Harmonic Drive has two different LCPs, one for the frequency converter (to the right) and one for the active filter (to the left). Each LCP controls only the unit it is connected to and there is no communication between the two LCPs. There is a start/stop signal between the two units.

Approvals

Table 1.2

Symbols

The following symbols are used in this manual.

⚠ WARNING

Indicates a potentially hazardous situation which, if not avoided, could result in death or serious injury.

⚠ CAUTION

Indicates a potentially hazardous situation which, if not avoided, may result in minor or moderate injury. It may also be used to alert against unsafe practices.

CAUTION

Indicates a situation that may result in equipment or property-damage-only accidents.

NOTE

Indicates highlighted information that should be regarded with attention to avoid mistakes or operate equipment at less than optimal performance.



2 Safety

2.1.1 Safety Note

⚠ WARNING

The voltage of the frequency converter is dangerous whenever connected to mains. Incorrect installation of the motor, frequency converter or fieldbus may cause damage to the equipment, serious personal injury or death. Consequently, the instructions in this manual, as well as national and local rules and safety regulations, must be complied with.

Safety Regulations

1. The frequency converter must be disconnected from mains if repair work is to be carried out. Check that the mains supply has been disconnected and that the necessary time has passed before removing motor and mains plugs.
2. The [Off/Reset] key on the LCP of the frequency converter does not disconnect the equipment from mains and is thus not to be used as a safety switch.
3. Correct protective earthing of the equipment must be established, the user must be protected against supply voltage, and the motor must be protected against overload in accordance with applicable national and local regulations.
4. The earth leakage currents are higher than 3.5 mA.
5. Protection against motor overload is set by *1-90 Motor Thermal Protection*. If this function is desired, set *1-90 Motor Thermal Protection* to data value [ETR trip] (default value) or data value [ETR warning].

NOTE

The function is initialised at 1.16 x rated motor current and rated motor frequency. For the North American market: The ETR functions provide class 20 motor overload protection in accordance with NEC.

6. Note that the frequency converter has voltage inputs other than L1, L2 and L3, when load sharing (linking of DC intermediate circuit) and external 24 V DC have been installed. Check that all voltage inputs have been disconnected and that the necessary time has passed before commencing repair work.

Installation at High Altitudes

⚠ WARNING

At altitudes above 3 km, contact Danfoss regarding PELV

Warning against Unintended Start

1. The motor can be brought to a stop by means of digital commands, bus commands, references or a local stop, while the frequency converter is connected to mains. If personal safety considerations make it necessary to ensure that no unintended start occurs, these stop functions are not sufficient.
2. While parameters are being changed, the motor may start. Consequently, the stop key [Reset] must always be activated; following which data can be modified.
3. A motor that has been stopped may start if faults occur in the electronics of the frequency converter, or if a temporary overload or a fault in the supply mains or the motor connection ceases.

⚠ WARNING

Touching the electrical parts may be fatal - even after the equipment has been disconnected from mains.

Also make sure that other voltage inputs have been disconnected, such as external 24 V DC, load sharing (linkage of DC intermediate circuit), as well as the motor connection for kinetic back up.

2.1.2 General Warning

⚠ WARNING

Touching the electrical parts may be fatal - even after the equipment has been disconnected from mains.

Also make sure that other voltage inputs have been disconnected, (linkage of DC intermediate circuit), as well as the motor connection for kinetic back-up.

Before touching any potentially live parts of the frequency converter, wait at least as follows:

380-480 V, 132-200 kW, wait at least 20 minutes.

380-480 V, 250-630 kW, wait at least 40 minutes.

Shorter time is allowed only if indicated on the nameplate for the specific unit. Be aware that there may be high voltage on the DC links even when the Control Card LEDs are turned off. A red LED is mounted on a circuit board inside both the frequency converter and the active filter to indicate the DC bus voltages. The red LED will stay lit until the DC link is 50 V DC or lower.

⚠ WARNING

Leakage Current

The earth leakage current from the frequency converter exceeds 3.5 mA. According to IEC 61800-5-1 a reinforced Protective Earth connection must be ensured by means of: a min. 10 mm² Cu or 16 mm² Al PE-wire or an additional PE wire - with the same cable cross section as the Mains wiring - must be terminated separately.

Residual Current Device

This product can cause a DC current in the protective conductor. Where a residual current device (RCD) is used for extra protection, only an RCD of Type B (time delayed) shall be used on the supply side of this product.

Protective earthing of the frequency converter and the use of RCDs must always follow national and local regulations.

2.1.3 Before Commencing Repair Work

1. Disconnect the frequency converter from mains
2. Disconnect DC bus terminals 88 and 89
3. Wait at least the time mentioned in 2.1.2 *General Warning*

2.1.4 Special Conditions

Electrical ratings

The rating indicated on the nameplate of the frequency converter is based on a typical 3-phase mains power supply, within the specified voltage, current and temperature range, which is expected to be used in most applications.

The frequency converters also support other special applications, which affect the electrical ratings of the frequency converter. Special conditions which affect the electrical ratings might be:

- Single phase applications
- High temperature applications which require derating of the electrical ratings
- Marine applications with more severe environmental conditions.

Consult the relevant clauses in these instructions and in the Design Guide for information about the electrical ratings.

Installation requirements

The overall electrical safety of the frequency converter requires special installation considerations regarding:

- Fuses and circuit breakers for over-current and short-circuit protection
- Selection of power cables (mains, motor, brake, loadsharing and relay)
- Grid configuration (IT,TN, grounded leg, etc.)

- Safety of low-voltage ports (PELV conditions).

Consult the relevant clauses in these instructions and in the Design Guide for information about the installation requirements.

2.1.5 Avoid Unintended Start

⚠ WARNING

While the frequency converter is connected to mains, the motor can be started/stopped using digital commands, bus commands, references or via the keypad.

- Disconnect the frequency converter from mains whenever personal safety considerations make it necessary to avoid unintended start.
- To avoid unintended start, always activate the [Off] key before changing parameters.
- An electronic fault, temporary overload, a fault in the mains supply, or lost motor connection may cause a stopped motor to start.

2.1.6 Safe Stop Installation

To carry out an installation of a Category 0 Stop (EN60204) in conformity with Safety Category 3 (EN954-1), follow these instructions:

1. The bridge (jumper) between Terminal 37 and 24 V DC must be removed. Cutting or breaking the jumper is not sufficient. Remove it entirely to avoid short-circuiting. See jumper on *Illustration 2.1*.
2. Connect terminal 37 to 24 V DC by a short-circuit protected cable. The 24 V DC voltage supply must be interruptible by an EN954-1 Category 3 circuit interrupt device. If the interrupt device and the frequency converter are placed in the same installation panel, an unscreened cable can be used instead of a screened one.

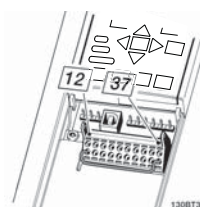
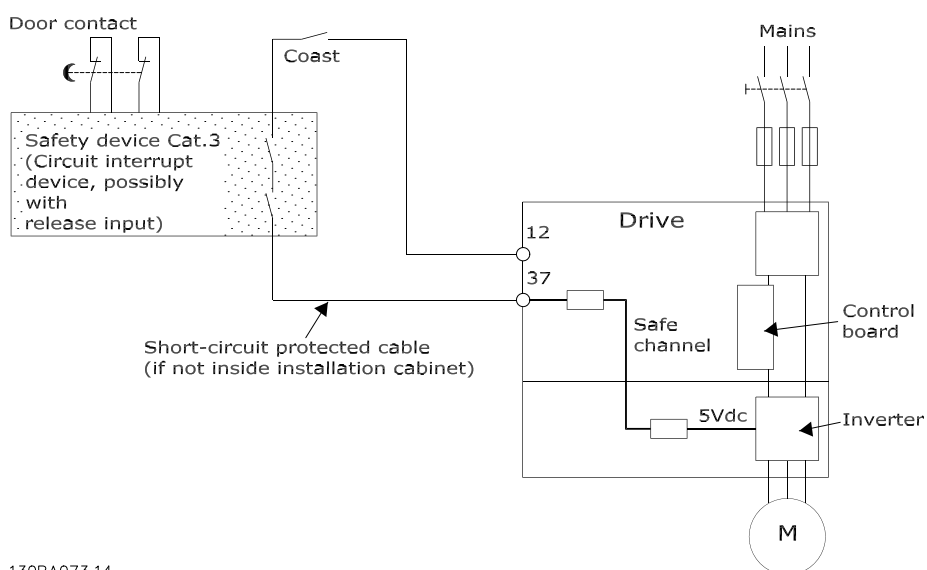

Illustration 2.1 Bridge jumper between terminal 37 and 24 V DC

Illustration 2.2 shows a Stopping Category 0 (EN 60204-1) with safety Category 3 (EN 954-1). The circuit interrupt is caused by an opening door contact. The illustration also shows how to connect a non-safety related hardware coast.



130BA073.14

Illustration 2.2 Illustration of the essential aspects of an installation to achieve a Stopping Category 0 (EN 60204-1) with safety Category 3 (EN 954-1).



2.1.7 Safe Stop of the Frequency Converter

2

For versions fitted with a Safe Stop terminal 37 input, the frequency converter can perform the safety function *Safe Torque Off* (As defined by draft CD IEC 61800-5-2) or *Stop Category 0* (as defined in EN 60204-1).

It is designed and approved suitable for the requirements of Safety Category 3 in EN 954-1. This functionality is called Safe Stop. Before integration and use of Safe Stop in an installation, a thorough risk analysis on the installation

must be carried out in order to determine whether the Safe Stop functionality and safety category are appropriate and sufficient. In order to install and use the Safe Stop function in accordance with the requirements of Safety Category 3 in EN 954-1, the related information and instructions of the *Design Guide* must be followed. The information and instructions of the Operating Instructions are not sufficient for a correct and safe use of the Safe Stop functionality.

Prüf- und Zertifizierungsstelle
im BG-PRÜFZERT



BGIA
Berufsgenossenschaftliches
Institut für Arbeitsschutz

Hauptverband der gewerblichen
Berufsgenossenschaften

Type Test Certificate

05 06004

No. of certificate

Translation
In any case, the German original shall prevail.

Name and address of the holder of the certificate: (customer)	Danfoss Drives A/S, Ulnaes 1 DK-6300 Graasten, Dänemark	
Name and address of the manufacturer:	Danfoss Drives A/S, Ulnaes 1 DK-6300 Graasten, Dänemark	
Ref. of customer:	Ref. of Test and Certification Body: Apf/Kösh VE-Nr. 2003 23220	Date of Issue: 13.04.2005
Product designation:	Frequency converter with integrated safety functions	
Type:	VLT® Automation Drive FC 302	
Intended purpose:	Implementation of safety function „Safe Stop“	
Testing based on:	EN 954-1, 1997-03, DKE AK 226.03, 1998-06, EN ISO 13849-2; 2003-12, EN 61800-3, 2001-02, EN 61800-5-1, 2003-09,	
Test certificate:	No.: 2003 23220 from 13.04.2005	
Remarks:	The presented types of the frequency converter FC 302 meet the requirements laid down in the test bases. With correct wiring a category 3 according to DIN EN 954-1 is reached for the safety function.	

The type tested complies with the provisions laid down in the directive 98/37/EC (Machinery).

Further conditions are laid down in the Rules of Procedure for Testing and Certification of April 2004.

Head of certification body

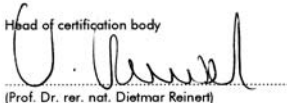

(Prof. Dr. rer. nat. Dietmar Reinert)

Certification officer

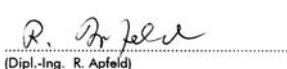

(Dipl.-Ing. R. Apfeld)

PZB10E
01.05



Postal address:
53754 Sankt Augustin

Office:
Alte Heerstraße 111
53757 Sankt Augustin

Phone: 0 22 41/2 31-02
Fax: 0 22 41/2 31-22 34

130BA373.11

Illustration 2.3

2.1.8 IT Mains

⚠ WARNING

IT mains

Do not connect frequency converters with option factory installed A1/B1 RFI filters to mains supplies with a voltage between phase and earth of more than 440 V for 400 V. For 400 V IT mains and delta earth (grounded leg), mains voltage may exceed 440 V between phase and earth.

14-50 RFI Filter can be used to disconnect the internal RFI capacitors from the RFI filter to ground. *14-50 RFI Filter* on both the frequency converter and the filter must be turned off.

2.1.9 Disposal Instruction

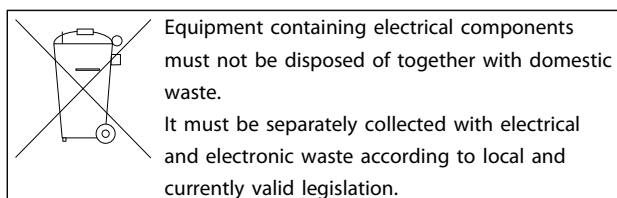

Table 2.1

3 Introduction to the Low Harmonic Drive

3.1.1 Working Principle

3

The VLT Low Harmonic Drive is a VLT High Power frequency converter with an integrated active filter. An active filter is a device that actively monitors harmonic

distortion levels and injects compensative harmonic current onto the line to cancel out the harmonics.

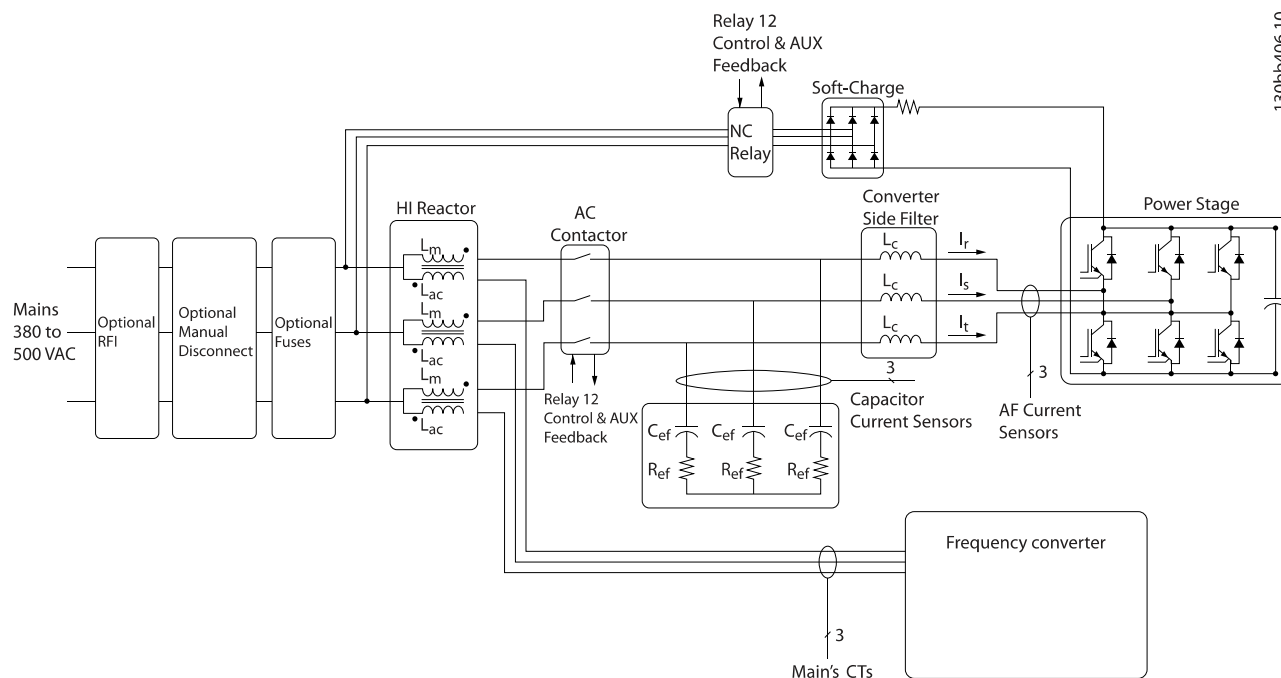

Illustration 3.1 Basic Layout for the Low Harmonic Drive

3.1.2 IEEE519 Compliance

Low harmonic drives are designed to draw an ideal sinusoidal current waveform from the supply grid with a power factor of 1. Where traditional non linear load draws pulse shaped currents the low harmonic drive compensates that via the parallel filter path lowering the stress on the supply grid. The Low harmonic drive meets the toughest harmonic standards and has a THiD of less than 5% at full load for <3% pre-distortion on a 3% unbalanced three-phased grid. The unit is designed to meet IEEE519 recommendation for $I_{sc}/I_L > 20$ for both uneven and even individual harmonic levels. The filter portion of the low harmonic drives has a progressive switching frequency which leads to a wide frequency spreads giving lower individual harmonic levels above the 50th.

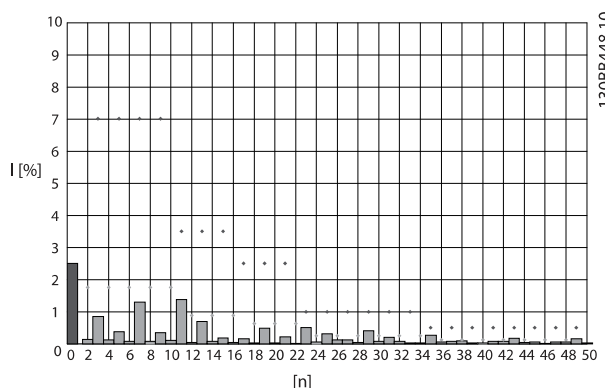

Illustration 3.2 Typical harmonic frequency spectrum and THD value at the mains terminals of the frequency converter

n = harmonic order

◇.....IEEE519 ($I_{sc}/I_L > 20$) limits for individual harmonics



3.1.3 Ordering Form Type Code

It is possible to design a VLT Low Harmonic Drive according to the application requirements by using the ordering number system.

1	2	3	4	5	6	7	8	9	10	11	12	13	14	15	16	17	18	19	20	21	22	23	24	25	26	27	28	29	-	-	30
F	C	-	X	0	2	P	X	X	0	T	4	E	2	1	N	2	X	G	C	X	X	X	S	X	X	X	X	X	.	.	X

3

Table 3.1

Product groups	1-3	<input type="text"/>
Frequency converter series	4-6	<input type="text"/>
Power rating	8-10	<input type="text"/>
Phases	11	<input type="text"/>
Mains Voltage	12	<input type="text"/>
Unit Size	13-15	<input type="text"/>
Unit type		<input type="text"/>
class		<input type="text"/>
Control supply voltage		<input type="text"/>
Hardware configuration		<input type="text"/>
RFI filter	16-17	<input type="text"/>
Brake	18	<input type="text"/>
Display (keypad)	19	<input type="text"/>
Coating PCB	20	<input type="text"/>
Mains option	21	<input type="text"/>
Adaptation A	22	<input type="text"/>
Adaptation B	23	<input type="text"/>
Software release	24-27	<input type="text"/>
Software language	28	<input type="text"/>
A options	29-30	<input type="text"/>
B options	31-32	<input type="text"/>
C0 options, MCO	33-34	<input type="text"/>
C1 options	35	<input type="text"/>
C option software	36-37	<input type="text"/>
D options	38-39	<input type="text"/>

Configurator on the Internet. For more information on the options available, see the *Design Guide*.

Table 3.2

To order a VLT Low Harmonic Drive, type the letter "N" in position 16 of the type code string. Not all choices/options are available for each frequency converter variant. To verify if the appropriate version is available, consult the Drive

4 How to Install

4

4.1 How to Get Started

This chapter covers mechanical and electrical installations to and from power terminals and control card terminals. Electrical installation of options is described in the relevant Operating Instructions and Design Guide.

The frequency converter is designed to achieve a quick and EMC-correct installation by following the steps described below.

⚠ WARNING

Read the safety instructions before installing the unit. Failure to follow recommendations could result in death or serious injury.

Mechanical Installation

- Mechanical mounting

Electrical Installation

- Connection to Mains and Protecting Earth
- Motor connection and cables
- Fuses and circuit breakers
- Control terminals - cables

Quick Setup

- Local Control Panel of filter
- Programming

Unit size is depending on enclosure type, power range, and mains voltage.

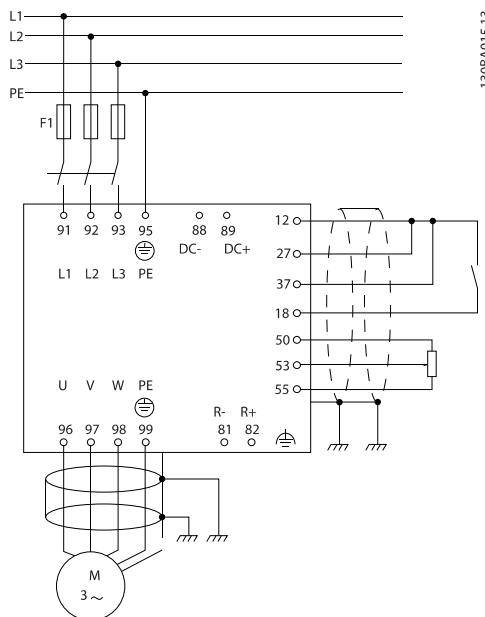

Illustration 4.1 Diagram showing basic installation including mains, motor, start/stop key, and potentiometer for speed adjustment.

4.2 Pre-installation

4.2.1 Planning the Installation Site

CAUTION

Before performing the installation it is important to plan the installation of the frequency converter. Neglecting this may result in extra work during and after installation.

Select the best possible operation site by considering the following (see details on the following pages, and the respective Design Guides)

- Ambient operating temperature
- Installation method
- How to cool the unit
- Position of the frequency converter
- Cable routing
- Ensure the power source supplies the correct voltage and necessary current
- Ensure that the motor current rating is within the maximum current from the frequency converter
- Ensure that the frequency converter is properly protected per local regulations.

4.2.2 Receiving the Frequency Converter

When receiving the frequency converter, make sure that the packaging is intact, and be aware of any damage that might have occurred to the unit during transport. In case damage has occurred, contact immediately the shipping company to claim the damage.

4.2.3 Transportation and Unpacking

Before unpacking the frequency converter it is recommended that it is located as close as possible to the final installation site.

Remove the box and handle the frequency converter on the pallet, as long as possible.

4.2.4 Lifting

Always lift the frequency converter in the dedicated lifting eyes. For all D and E frames, use a bar to avoid bending the lifting holes of the frequency converter.

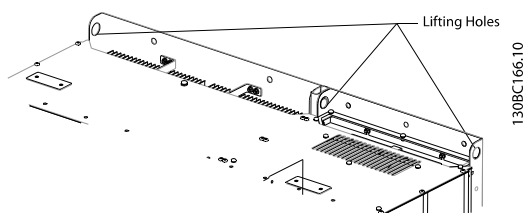

Illustration 4.2 Recommended lifting method, frame size D 13

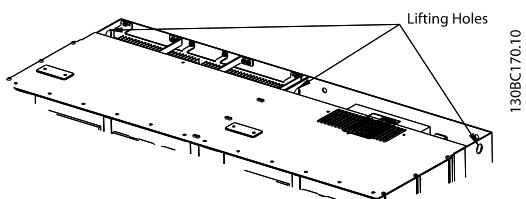

Illustration 4.3 Recommended lifting method, frame size E 9

⚠ WARNING

The lifting bar must be able to handle the weight of the frequency converter. See 4.2.5 *Mechanical Dimensions* for the weight of the different frame sizes. Maximum diameter for bar is 2.5 cm (1 inch). The angle from the top of the frequency converter to the lifting cable should be 60° or greater.

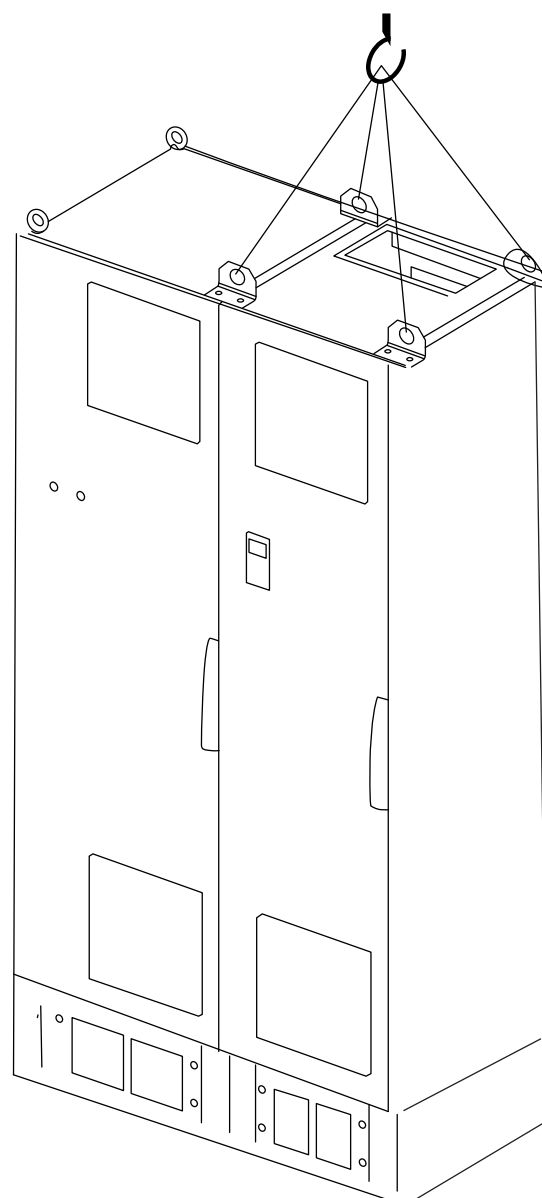
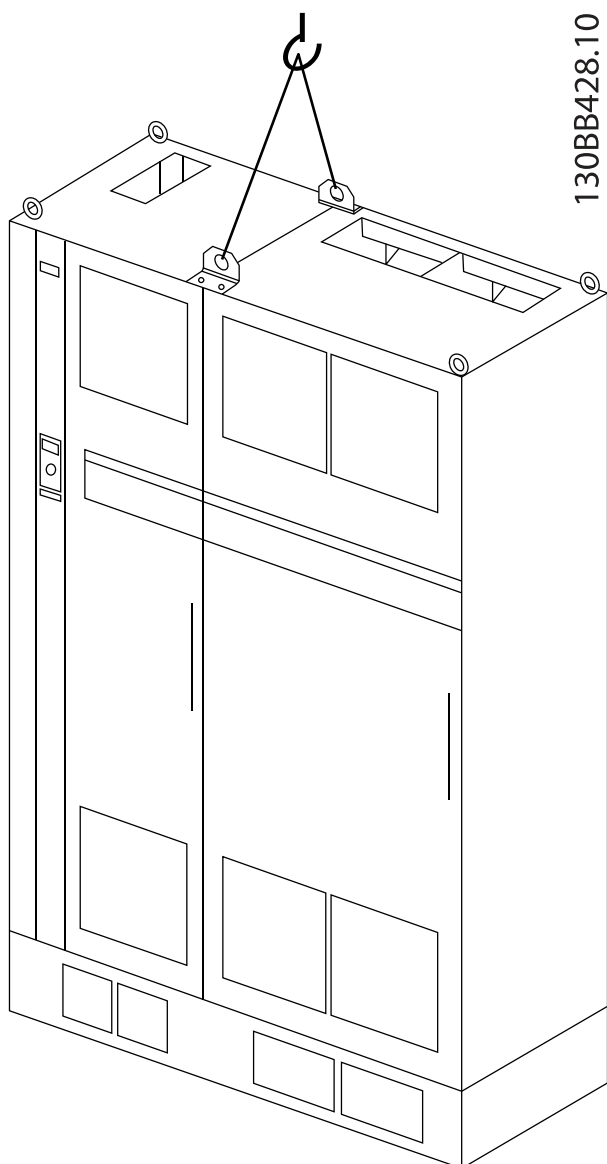

Illustration 4.4 Recommended lifting method, frame size F18 - filter section.



4



NOTE

The F size is shipped as 2 pieces. Instructions on how to assemble the pieces can be found in 4.3 *Mechanical Installation*.

Illustration 4.5 Recommended lifting method, frame size F18 - drive section.

NOTE

Note the plinth is provided in the same packaging as the frequency converter but is not attached to frame size F during shipment. The plinth is required to allow airflow to the frequency converter to provide proper cooling. The F frames should be positioned on top of the plinth in the final installation location. The angle from the top of the frequency converter to the lifting cable should be 60° or greater.

In addition to the drawing above a spreader bar is an acceptable way to lift the F Frame.



4.2.5 Mechanical Dimensions

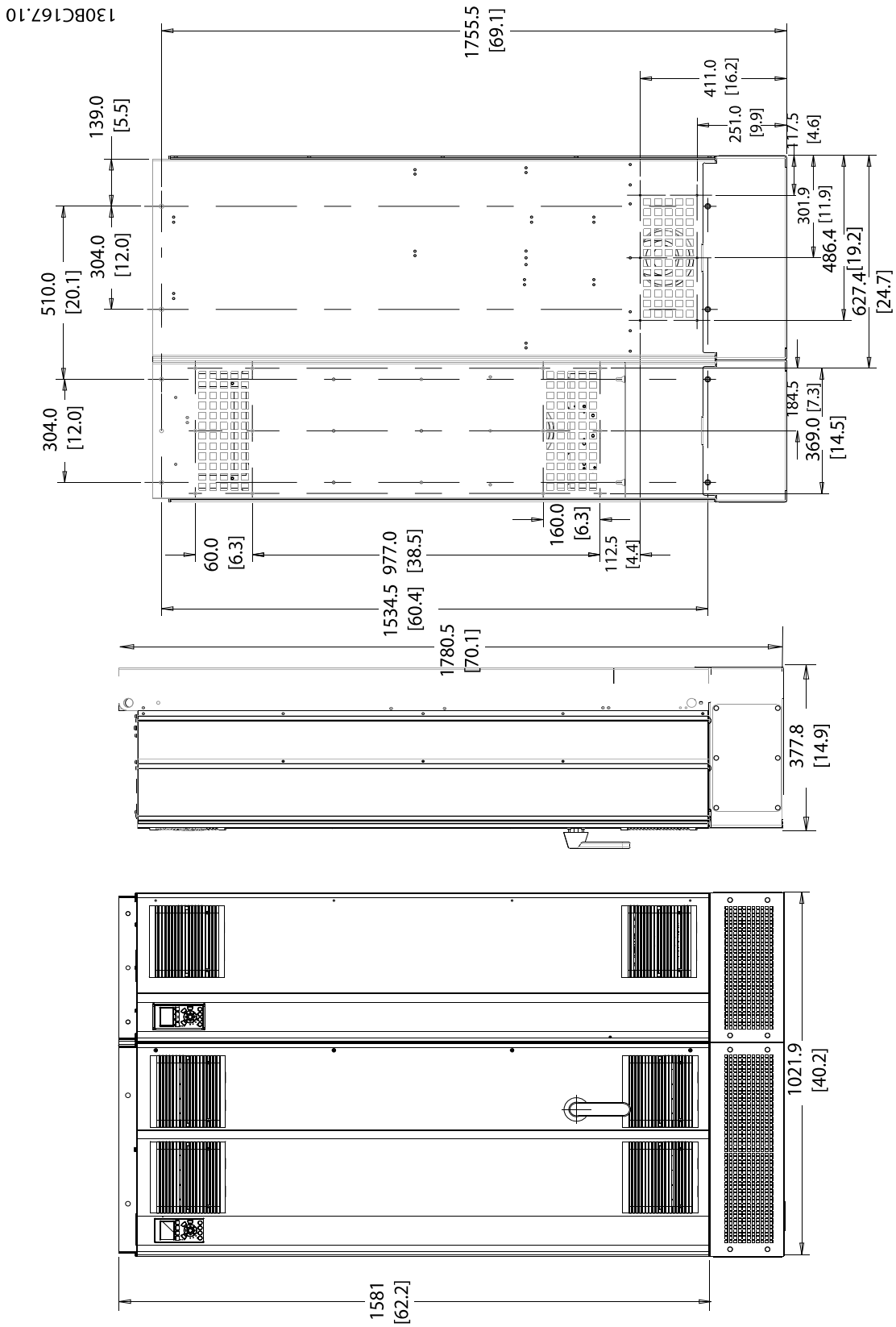

Illustration 4.6 Frame Size D13

4

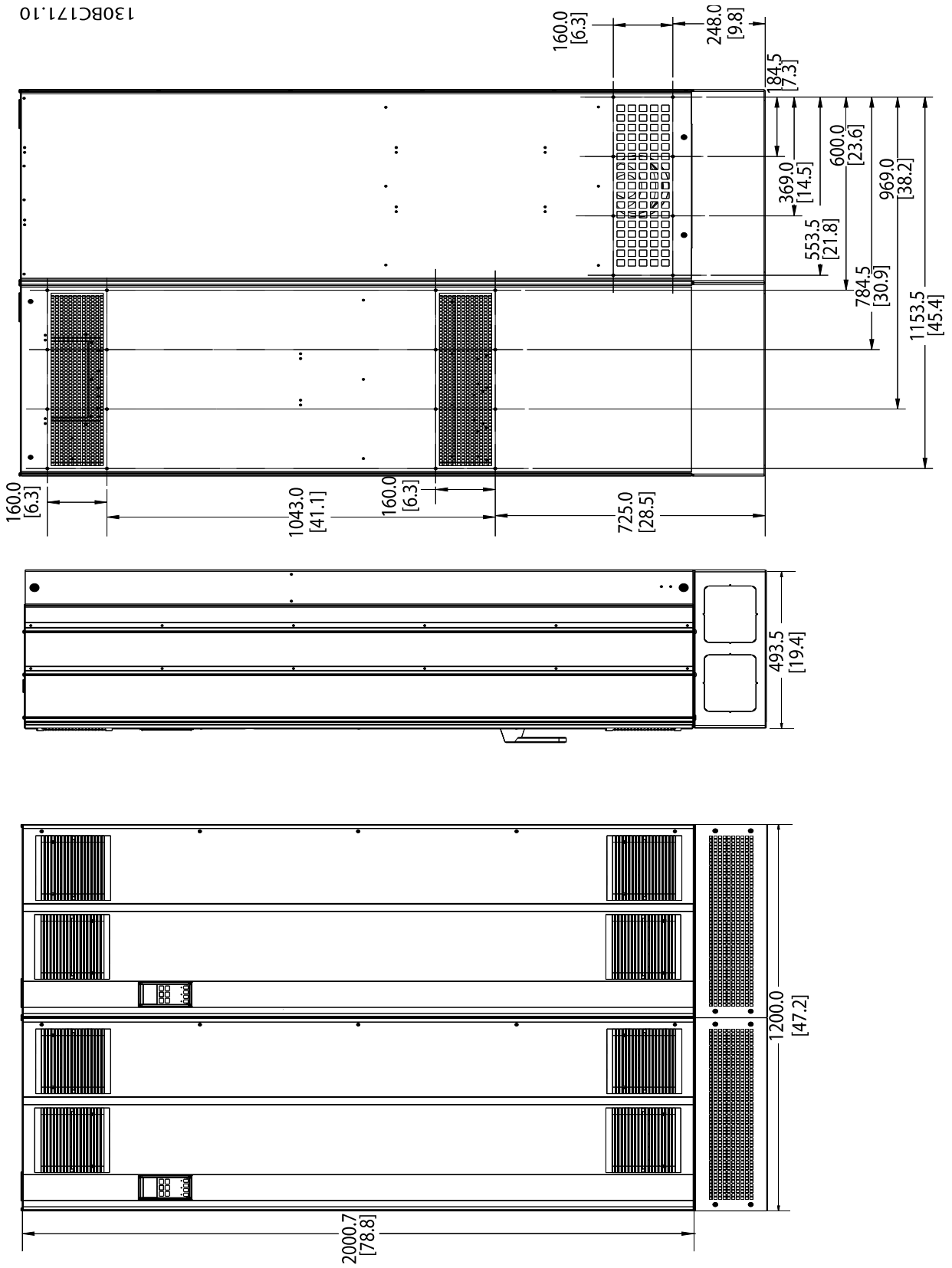

Illustration 4.7 Frame Size E9

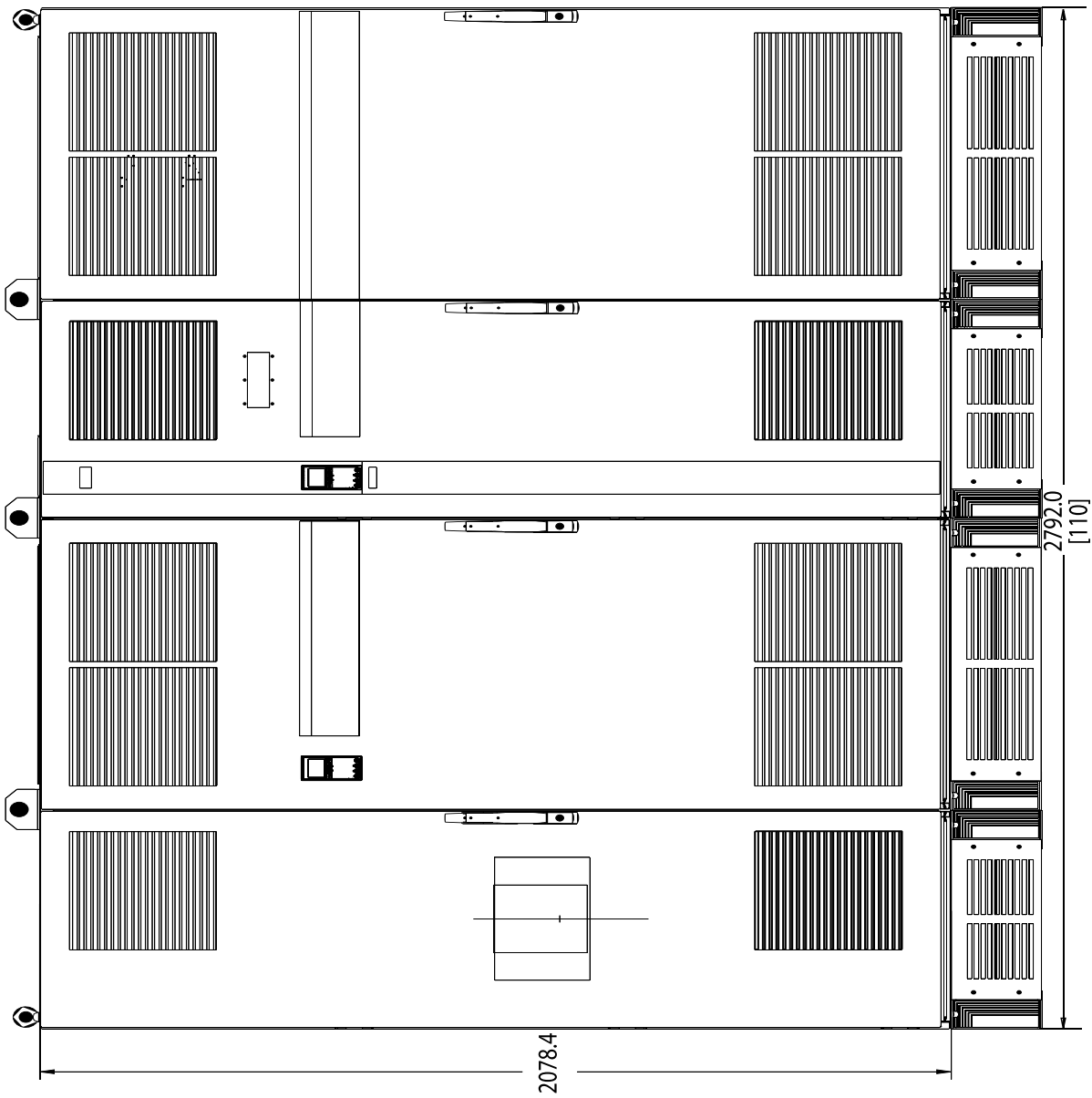
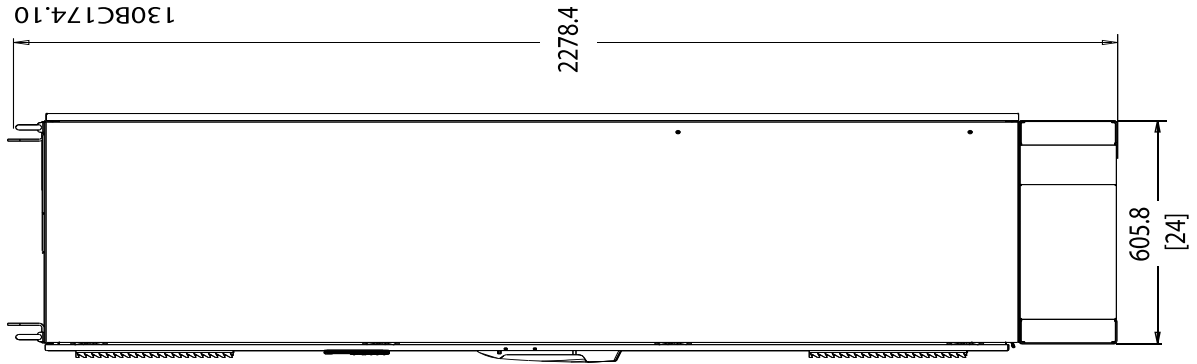

Illustration 4.8 Frame Size F18, Front and Side View



4

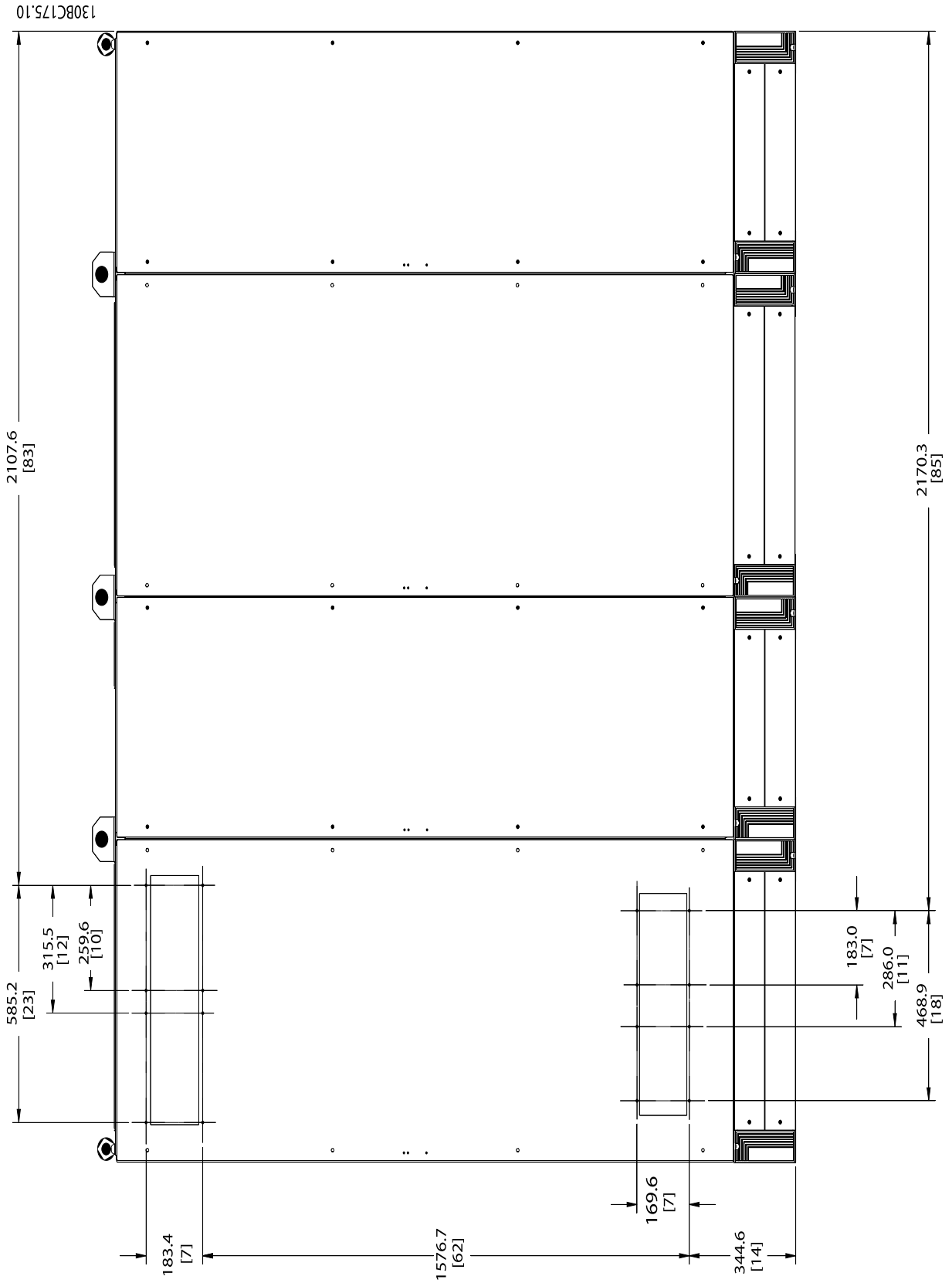

Illustration 4.9 Frame Size F18, Back View



Frame size		D13	E9
Enclosure protection	IP	21/54	21/54*
	NEMA	Type 1/Type 12	Type 1/Type 12
Normal overload rated power - 110% overload torque		160-250 kW at 400 V (380-480 V)	315-450 kW at 400 V (380-480 V)
Drive Dimensions	Height	1780.5 mm/70.1"	2000.7 mm/78.77"
	Width	1021.9 mm/40.23"	1200 mm/47.24"
	Depth	377.8 mm/14.87"	493.5 mm/19.43"
	Max Weight	390 kg/860 lbs.	676 kg/1490 lbs.
	Shipping Weight	435 kg/959 lbs.	721 kg/1590 lbs.

4

Table 4.1 Mechanical Dimensions and Rated Power, Frame Size D13 and E9

Frame size		F18
Enclosure protection	IP	21/54
	NEMA	Type 1
Normal overload rated power - 110% overload torque		500-710 kW at 400 V (380-480 V)
Drive Dimensions	Height	2278.4 mm/89.70"
	Width	2792 mm/109.92"
	Depth	605.8 mm/23.85"
	Max Weight	1900 kg/4189 lbs.
	Shipping Weight	2262 kg/4987 lbs.

Table 4.2 Mechanical Dimensions and Rated Power, Frame Size F18

4.3 Mechanical Installation

Preparation of the mechanical installation of the frequency converter must be done carefully to ensure a proper result and to avoid additional work during installation. Start taking a close look at the mechanical drawings at the end of this instruction to become familiar with the space demands.

4

4.3.1 Tools Needed

To perform the mechanical installation the following tools are needed:

- Drill with 10 or 12 mm drill
- Tape measure
- Screw driver
- Wrench with relevant metric sockets (7-17 mm)
- Extensions to wrench
- Sheet metal punch for conduits or cable glands
- Lifting bar to lift the unit (rod or tube max. Ø 25 mm (1 inch), able to lift minimum 1000 kg).
- Crane other lifting aid to place the unit in position
- Torx T50 tool

4.3.2 General Considerations

Space

Ensure proper space above and below the frequency converter to allow airflow and cable access. In addition space in front of the unit must be considered to enable opening of the door of the panel.

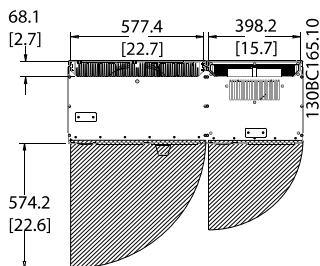

Illustration 4.10 Space in front of IP21/IP54 enclosure type, frames size D13

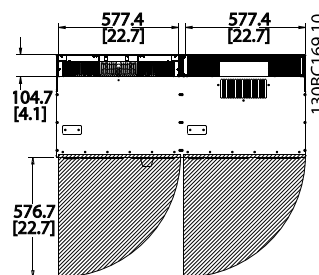

Illustration 4.11 Space in front of IP21/IP54 enclosure type, frame size E9

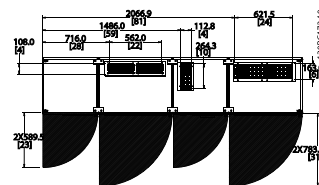

Illustration 4.12 Space in front of IP21/IP54 enclosure type, frame size F18.

Wire access

Ensure that proper cable access is present including necessary bending allowance.

NOTE

All cable lugs/shoes must mount within the width of the terminal bus bar.



4.3.3 Terminal Locations - Frame Size D13

Take the following position of the terminals into consideration when designing for cables access.

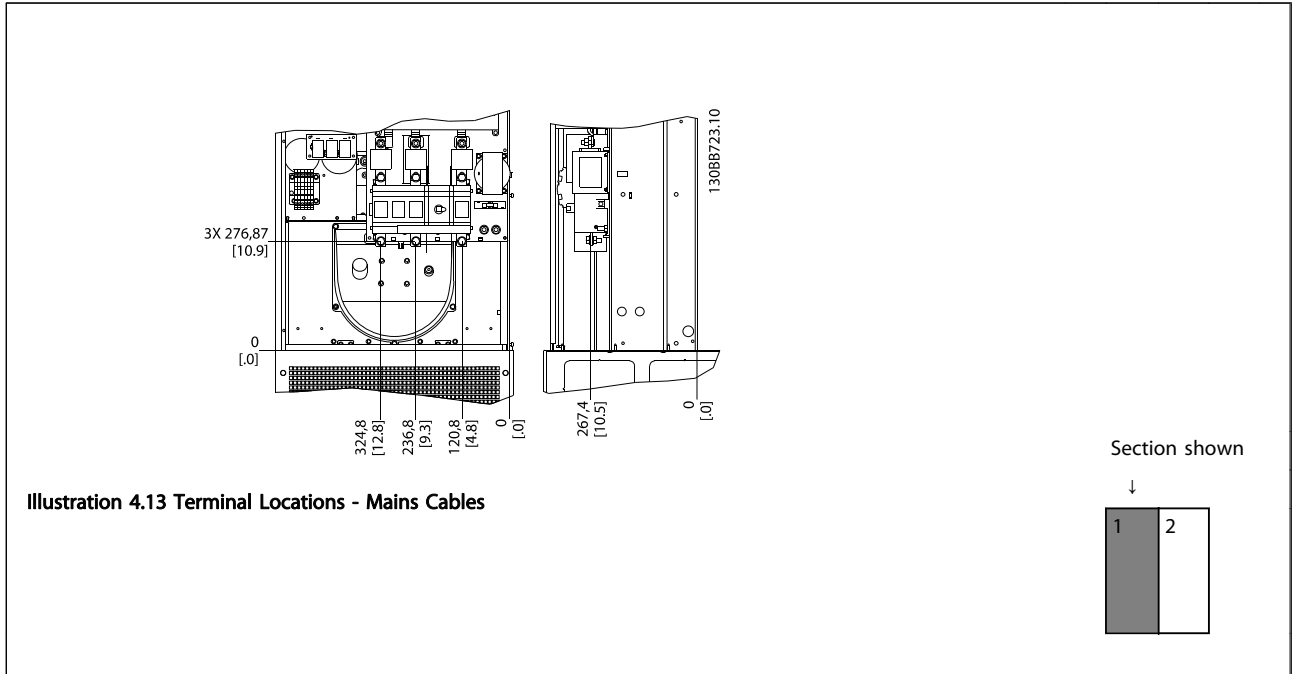

Table 4.3

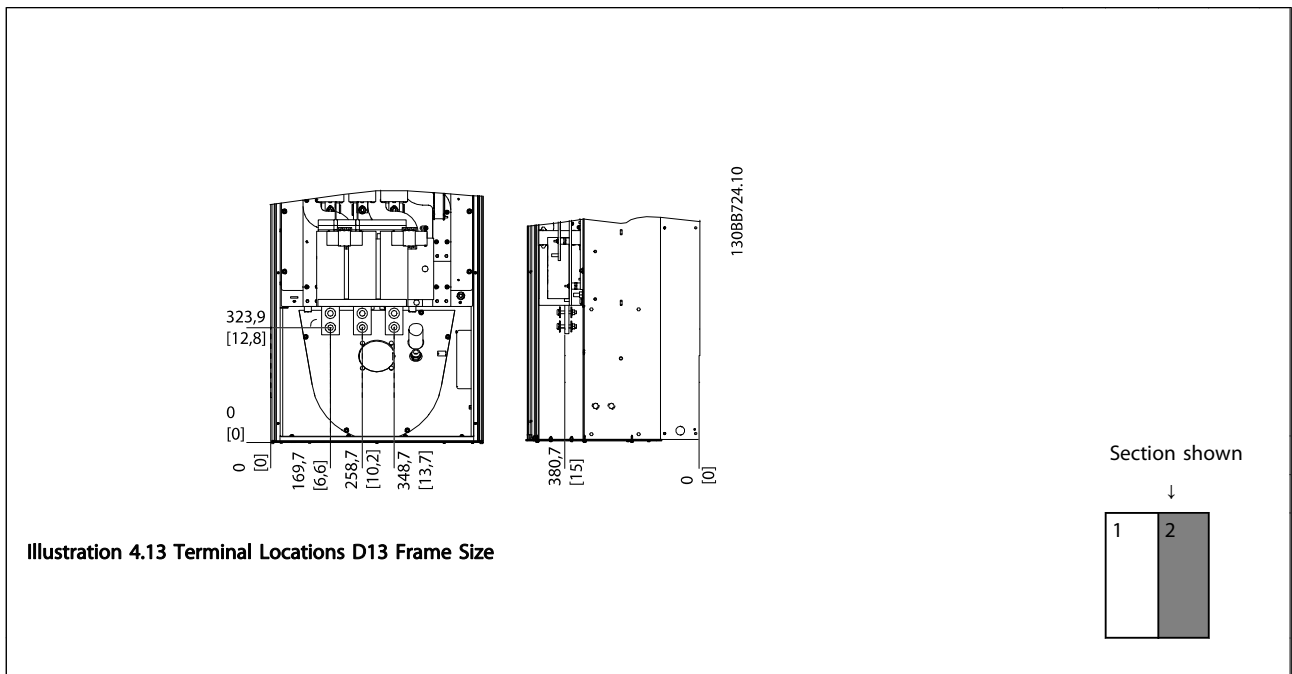

Table 4.4

NOTE

Power cables are heavy and hard to bend. Consider the optimum position of the frequency converter for ensuring easy installation of the cables.

NOTE

All 4X Unit Sizes are available with standard input terminals.

4.3.4 Terminal Locations - Frame Size E9

Take the following position of the terminals into consideration when designing the cable access.

4

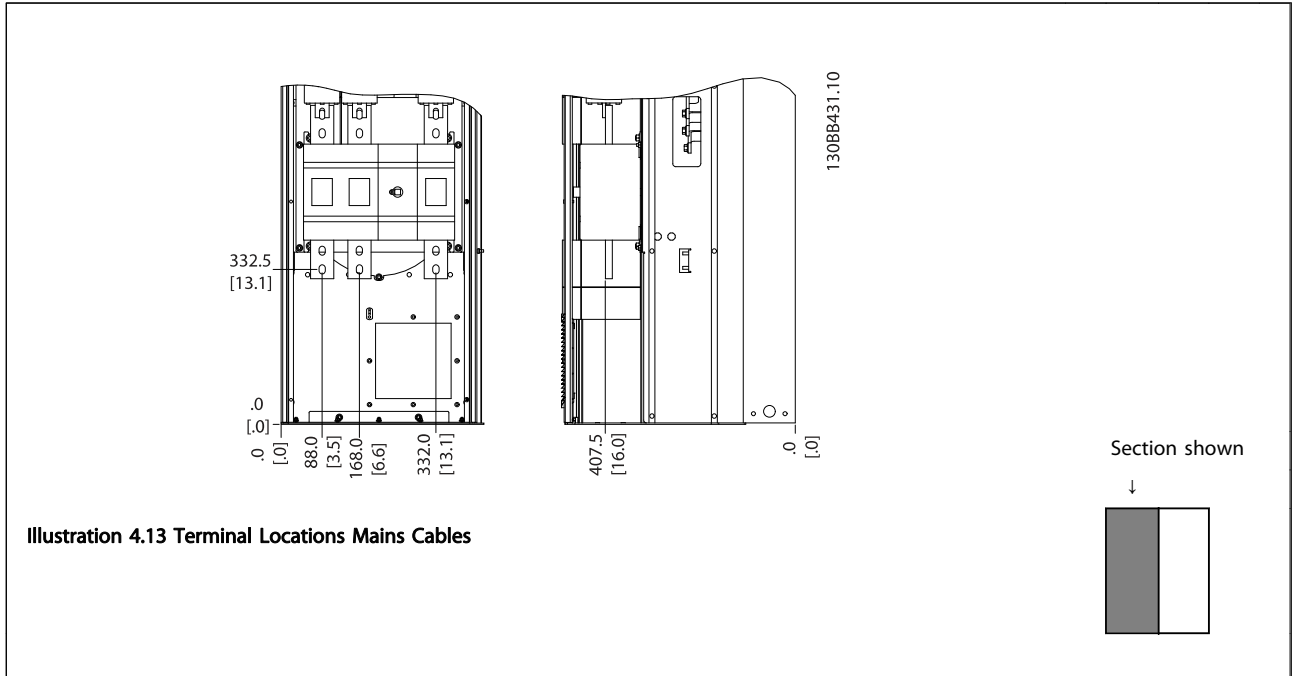

Table 4.5

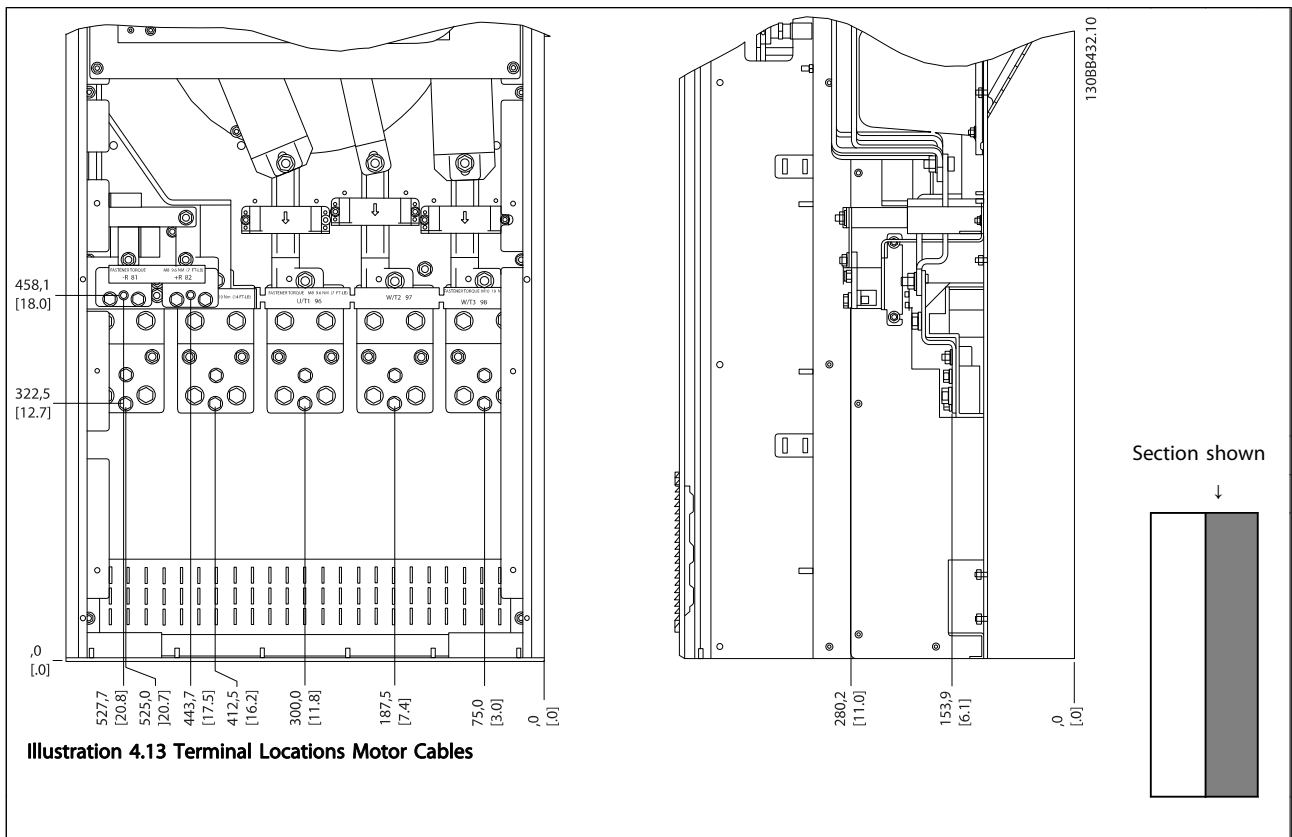

Table 4.6

NOTE

Power cables are heavy and hard to bend. Consider the optimum position of the frequency converter for ensuring easy installation of the cables.

Each terminal allows use of up to 4 cables with cable lugs or use of standard box lug. Earth is connected to relevant termination point in the frequency converter.

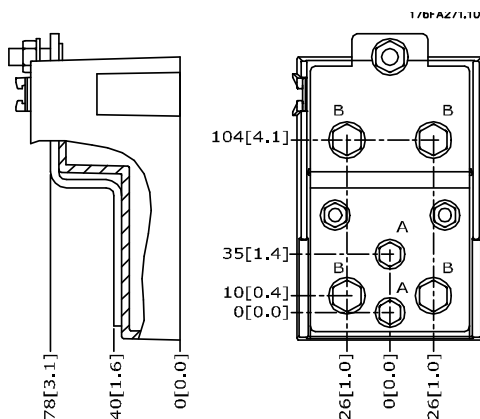

Illustration 4.13 Terminal in Details

NOTE

Power connections can be made to positions A or B.

4.3.5 Terminal Locations -

4

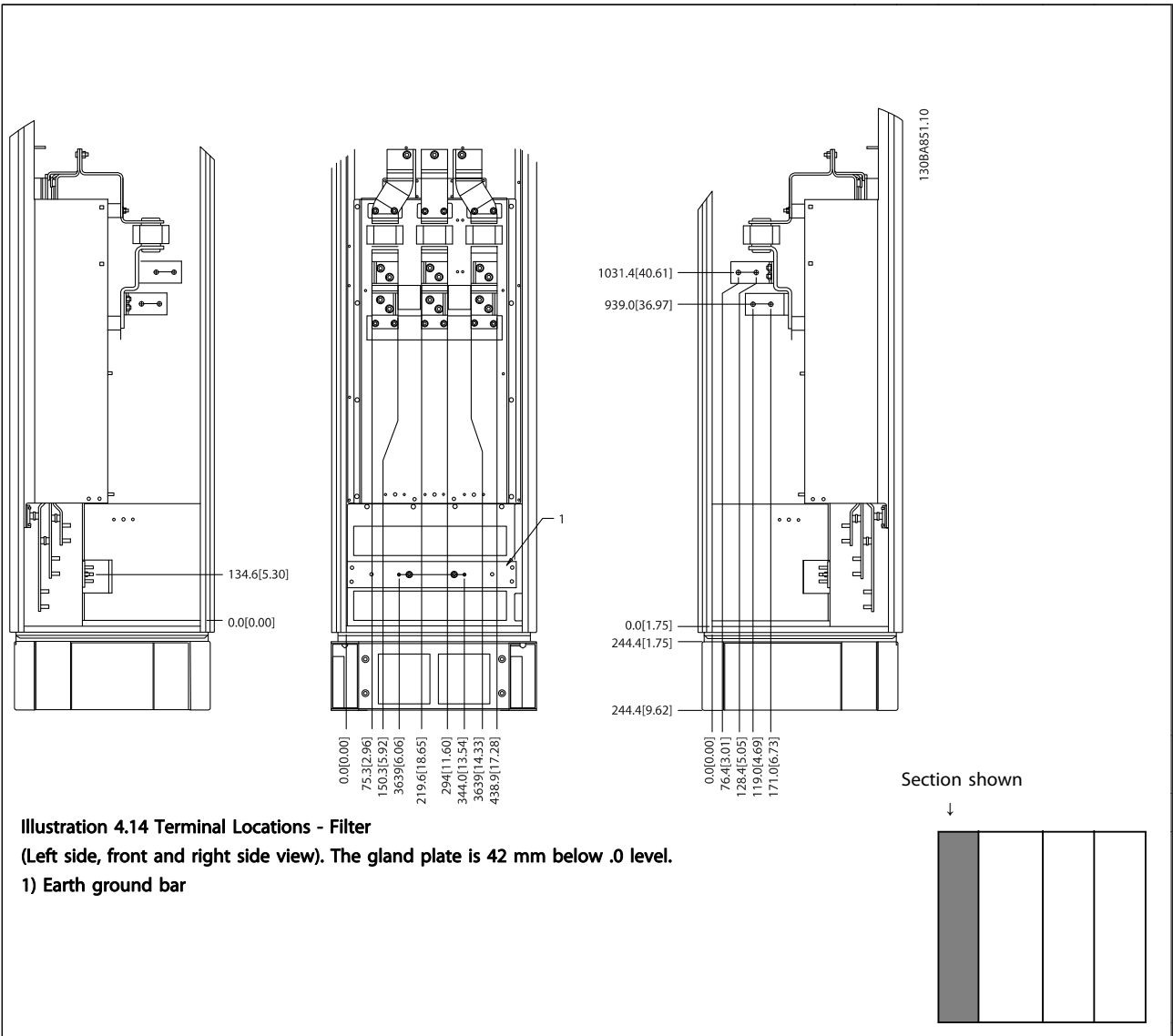

Illustration 4.14 Terminal Locations - Filter
 (Left side, front and right side view). The gland plate is 42 mm below .0 level.
 1) Earth ground bar

Table 4.7

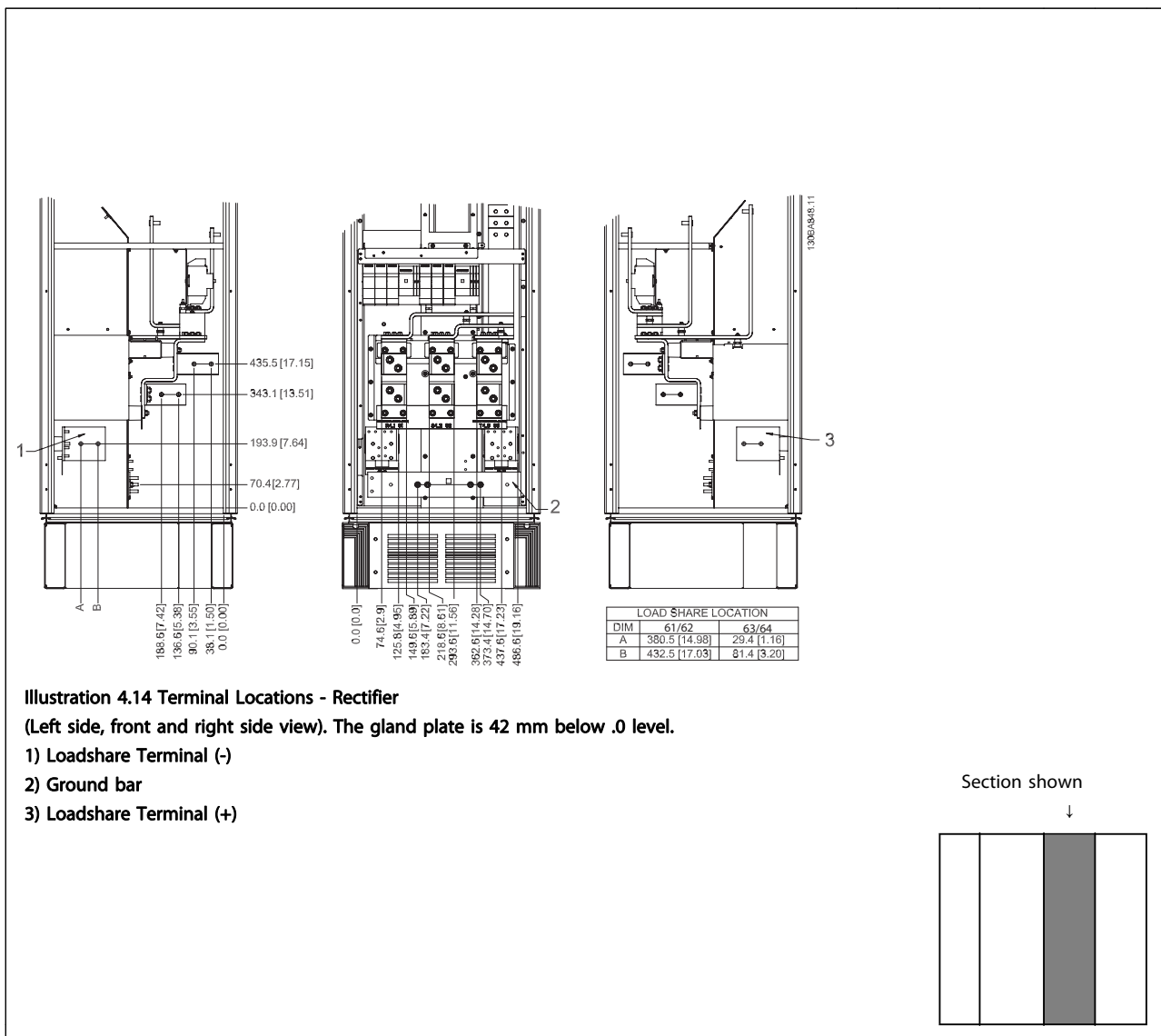

Illustration 4.14 Terminal Locations - Rectifier

(Left side, front and right side view). The gland plate is 42 mm below .0 level.

- 1) Loadshare Terminal (-)
- 2) Ground bar
- 3) Loadshare Terminal (+)

Section shown

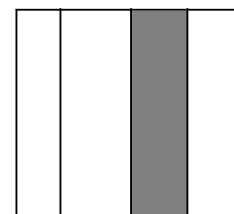

Table 4.8

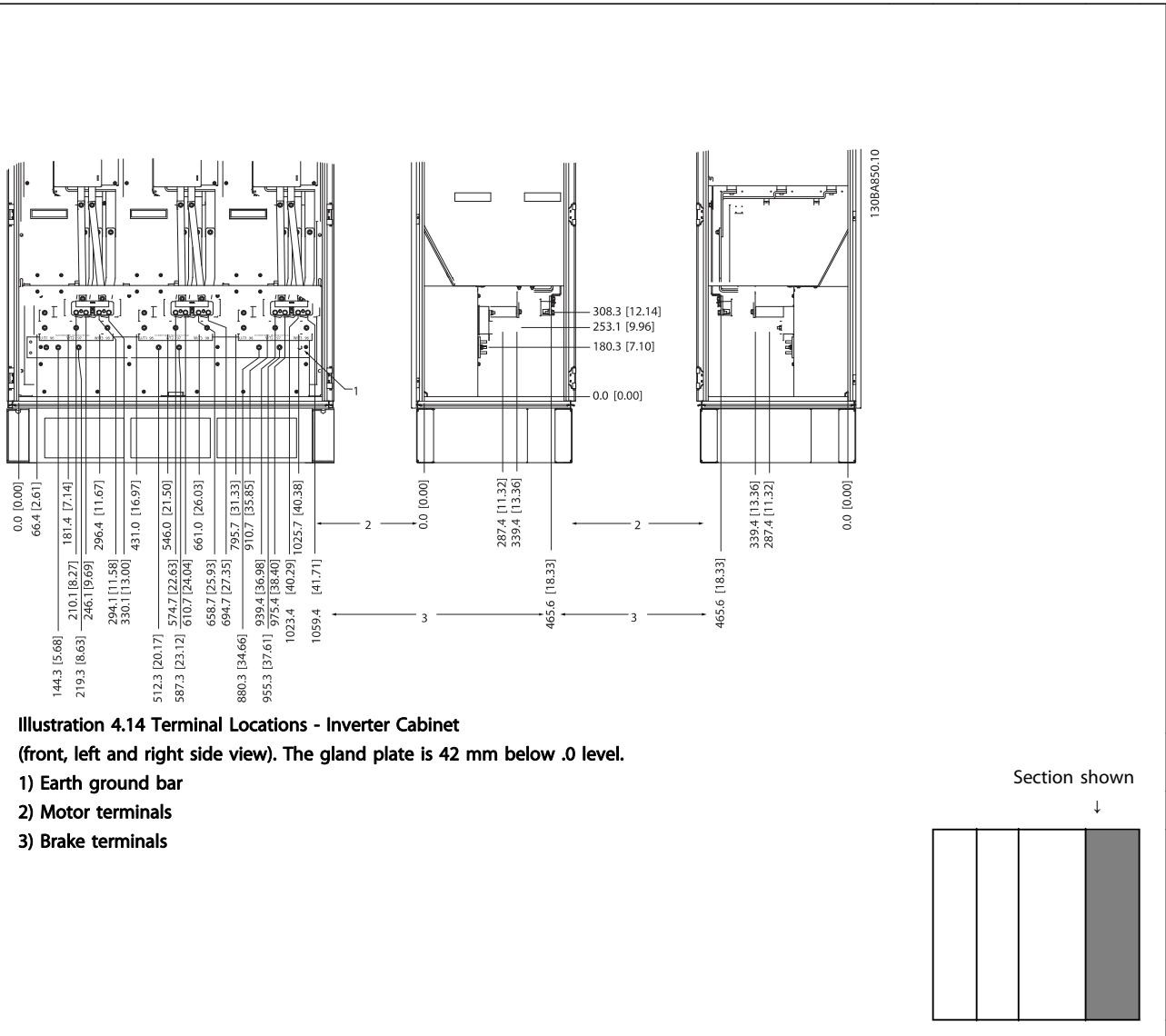

Table 4.9



4.3.6 Cooling and Airflow

Cooling

Cooling can be obtained in different ways, by using the cooling ducts in the bottom and the top of the unit, by taking air in and out the back of the unit or by combining the cooling possibilities.

Back cooling

The backchannel air can also be ventilated in and out the back of a Rittal TS8 Unit. This offers a solution where the backchannel could take air from outside the facility and return the heat losses outside the facility thus reducing air-conditioning requirements.

NOTE

A door fan(s) is required on the enclosure to remove the heat losses not contained in the backchannel of the frequency converter and any additional losses generated from other components installed inside the enclosure. The total required air flow must be calculated so that the appropriate fans can be selected. Some enclosure manufacturers offer software for performing the calculations (i.e. Rittal Therm software).

Airflow

The necessary airflow over the heat sink must be secured. The flow rate is shown below.

Unit Size protection	Unit Size	Door fan(s)/Top fan airflow Total airflow of multiple fans	Heatsink fan(s) Total airflow of multiple fans
IP21/NEMA 1 IP54/NEMA 12	D13	510 m ³ /h (300 cfm)	2295 m ³ /h (1350 cfm)
	E9 P315	680 m ³ /h (400 cfm)	2635 m ³ /h (1550 cfm)
IP21/NEMA 1	E9 P355-P450	680 m ³ /h (400 cfm)	2975 m ³ /h (1750 cfm)
	F18	4900 m ³ /h (2884 cfm)	6895 m ³ /h (4060 cfm)

Table 4.10 Heatsink Air Flow

External ducts

If additional duct work is added externally to the Rittal cabinet the pressure drop in the ducting must be calculated. Use the charts below to derate the frequency converter according to the pressure drop.

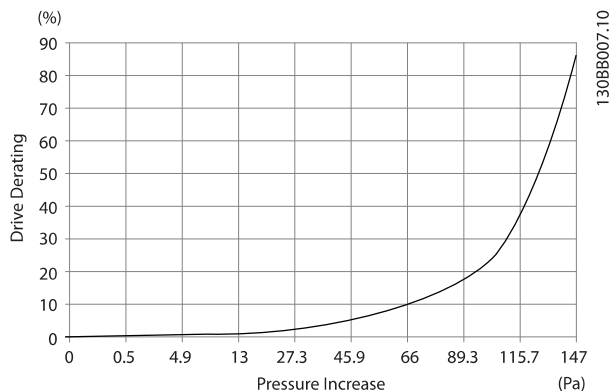

Illustration 4.14 D Frame Derating vs. Pressure Change
Drive Air Flow: 450 cfm (765 m³/h)

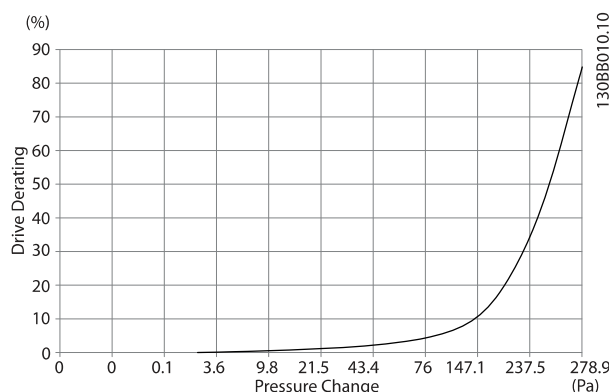

Illustration 4.15 E Frame Derating vs. Pressure Change 250-315 KW

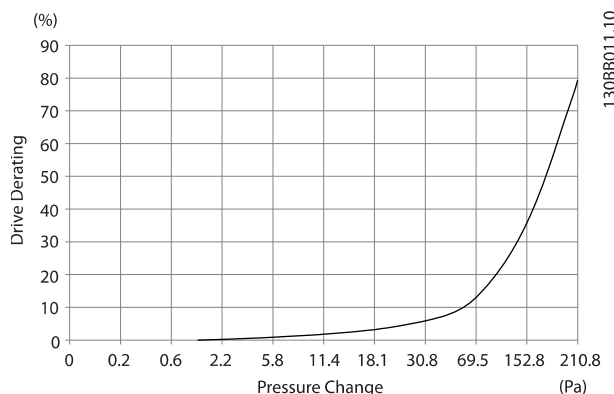

Illustration 4.16 E Frame Derating vs. Pressure Change 355-450 KW

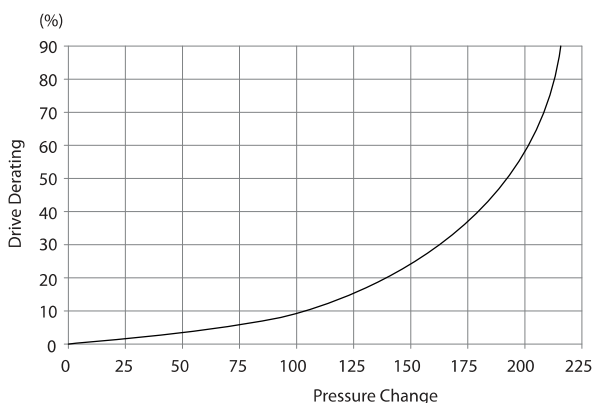

Illustration 4.17 F Frame Derating vs. Pressure Change
Drive Air Flow: 580 cfm (985 m³/h)

NOTE

The gland plate must be fitted to the frequency converter to ensure the specified protection degree, as well as ensuring proper cooling of the unit. If the gland plate is not mounted, the frequency converter may trip on Alarm 69, Pwr. Card Temp

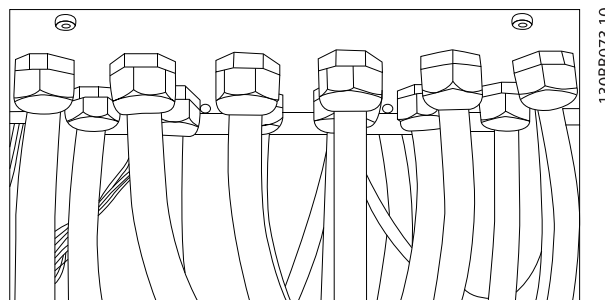

Illustration 4.18 Example of Proper Installation of the Gland Plate.

4.3.7 Gland/Conduit Entry - IP21 (NEMA 1) and IP54 (NEMA12)

Cables are connected through the gland plate from the bottom. Remove the plate and plan where to place the entry for the glands or conduits. Prepare holes in the marked area on the drawing.

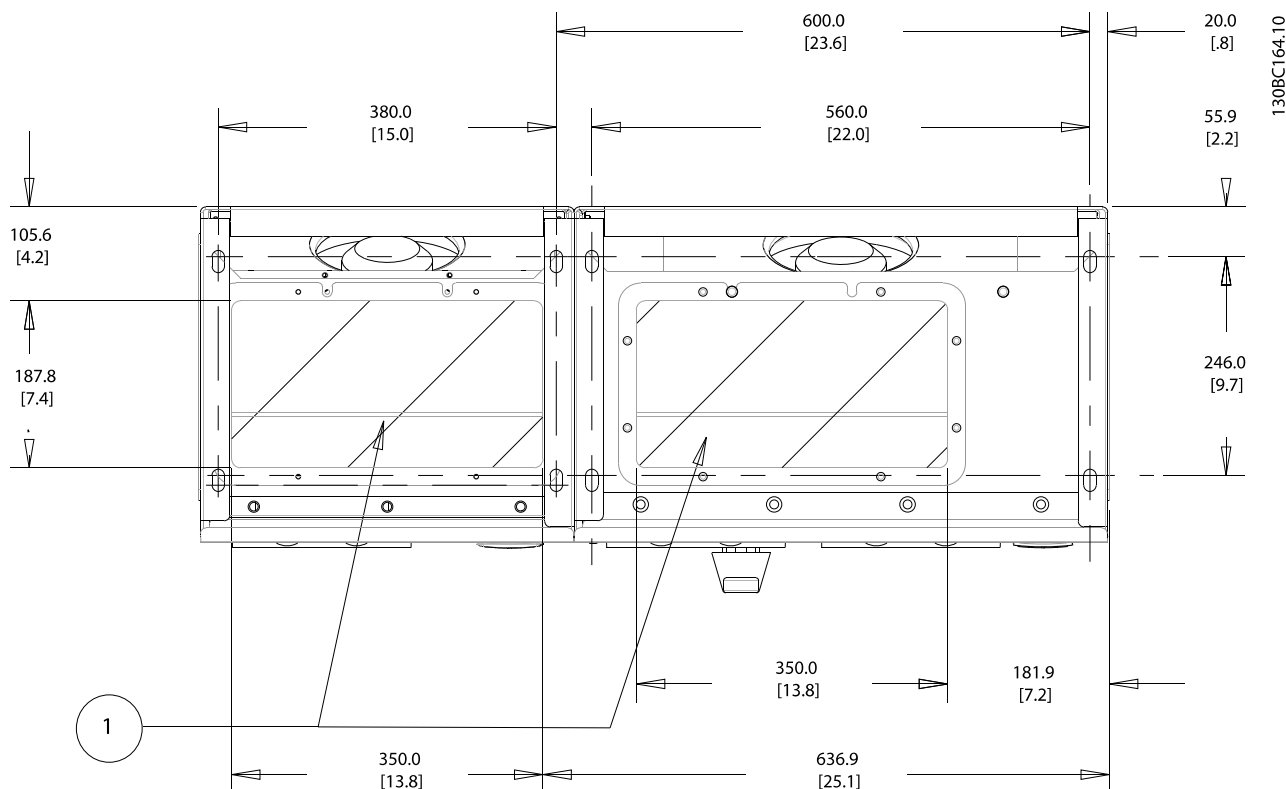

Illustration 4.19 Frame Size D13

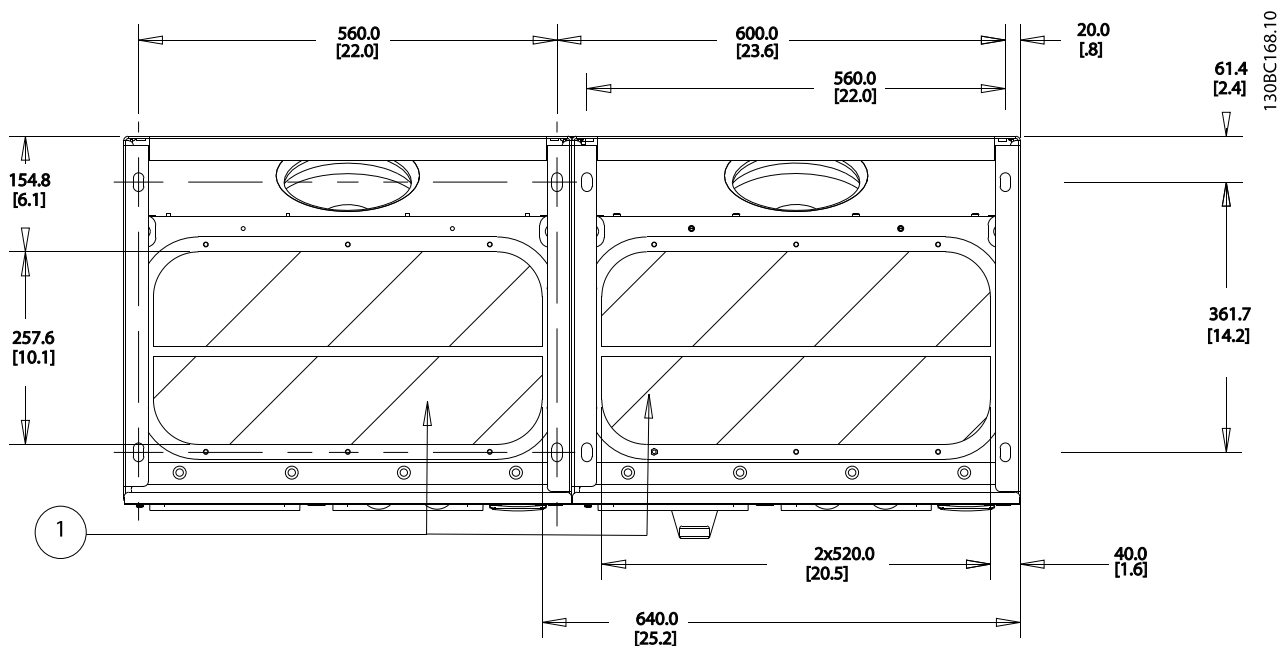

Illustration 4.20 Frame Size E9

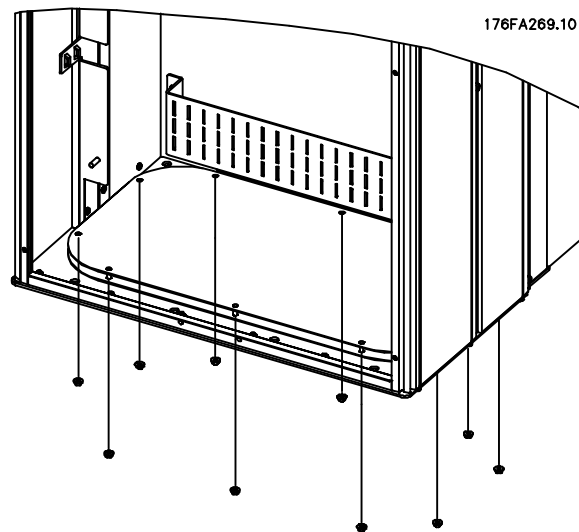
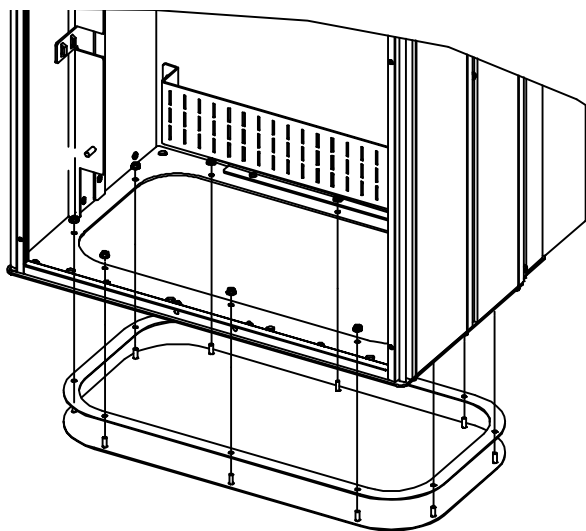

Illustration 4.21 Mounting of Bottom Plate, E9 Frame Size

The bottom plate of the E frame can be mounted from either in- or outside of the enclosure, allowing flexibility in the installation process, i.e. if mounted from the bottom

the glands and cables can be mounted before the frequency converter is placed on the pedestal.

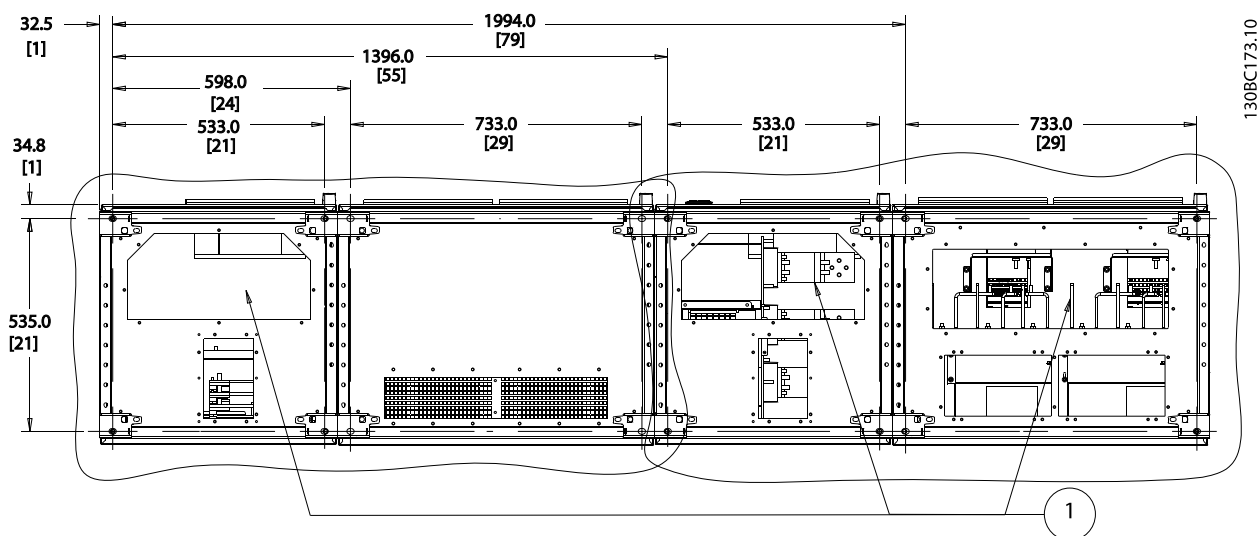

Illustration 4.22 Frame Size F18

Cable entries viewed from the bottom of the frequency converter

- 1) Mains cable connection
- 2) Motor cable connection

4

4.3.8 IP21 Drip Shield Installation (Frame Size D)

To comply with the IP21 rating, a separate drip shield is to be installed as explained below

1. Remove the two front screws
2. Insert the drip shield and replace screws
3. Torque the screws to 5.6 Nm (50 in-lbs)

NOTE

Drip shield is necessary on both filter and drive section.

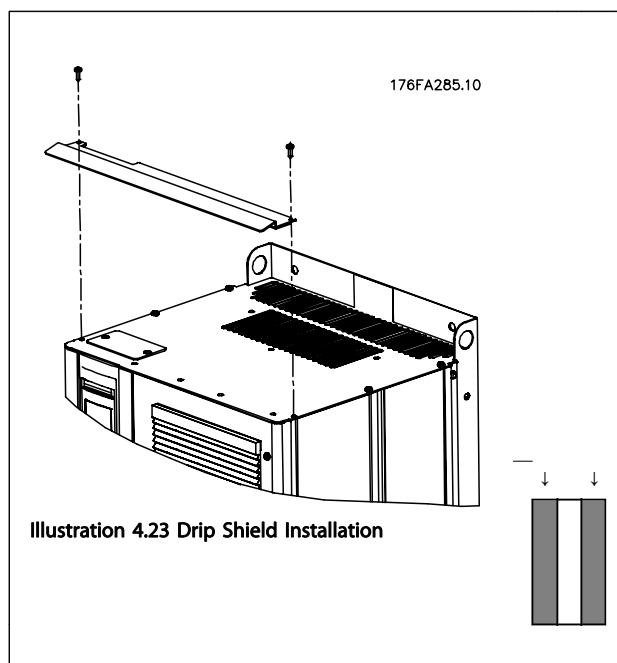

Illustration 4.23 Drip Shield Installation

Table 4.11

4.4 Field Installation of Options

4.4.1 Installation of Mains Shield for Frequency Converters

The mains shield is for installation with D and E frames and satisfy BG-4 requirements.

Ordering numbers:

NOTE

For further information,

4.5 Frame Size F Panel Options

4.6 Electrical Installation

4.6.1 Power Connections

Cabling and Fusing

NOTE

Cables General

All cabling must comply with national and local regulations on cable cross-sections and ambient temperature. UL applications require 75 °C copper conductors. 75 and 90 °C copper conductors are thermally acceptable for the frequency converter to use in non UL applications.

The power cable connections are situated as shown below. Dimensioning of cable cross section must be done in accordance with the current ratings and local legislation. See 8 *General Specifications* for details.

For protection please see fuse in 4.6.13 *Fuse Specifications*. Always ensure that proper fusing is made according to local regulation.

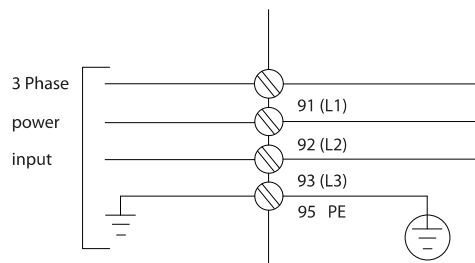

Illustration 4.23

NOTE

See 8 *General Specifications* for correct dimensioning of motor cable cross-section and length.

Screening of cables

Avoid installation with twisted screen ends (pigtailed). They spoil the screening effect at higher frequencies. If it is necessary to break the screen to install a motor isolator or motor contactor, the screen must be continued at the lowest possible HF impedance.

Connect the motor cable screen to both the de-coupling plate of the frequency converter and to the metal housing of the motor.

Make the screen connections with the largest possible surface area (cable clamp). This is done by using the

supplied installation devices within the frequency converter.

Cable-length and cross-section

The frequency converter has been EMC tested with a given length of cable. Keep the motor cable as short as possible to reduce the noise level and leakage currents.

Switching frequency

When frequency converters are used together with Sine-wave filters to reduce the acoustic noise from a motor, the switching frequency must be set according to the instruction in 14-01 *Switching Frequency*.

4

Term. no.	96	97	98	99	
	U	V	W	PE ¹⁾	Motor voltage 0-100% of mains voltage. 3 wires out of motor
	U1	V1	W1	PE ¹⁾	Delta-connected
	W2	U2	V2		6 wires out of motor
	U1	V1	W1	PE ¹⁾	Star-connected U2, V2, W2 U2, V2 and W2 to be interconnected separately.

Table 4.12

¹⁾ Protected Earth Connection

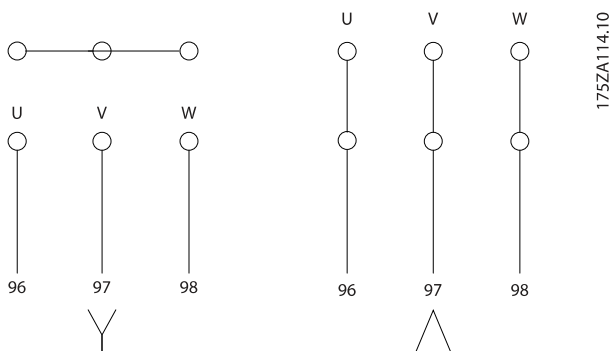

Illustration 4.24

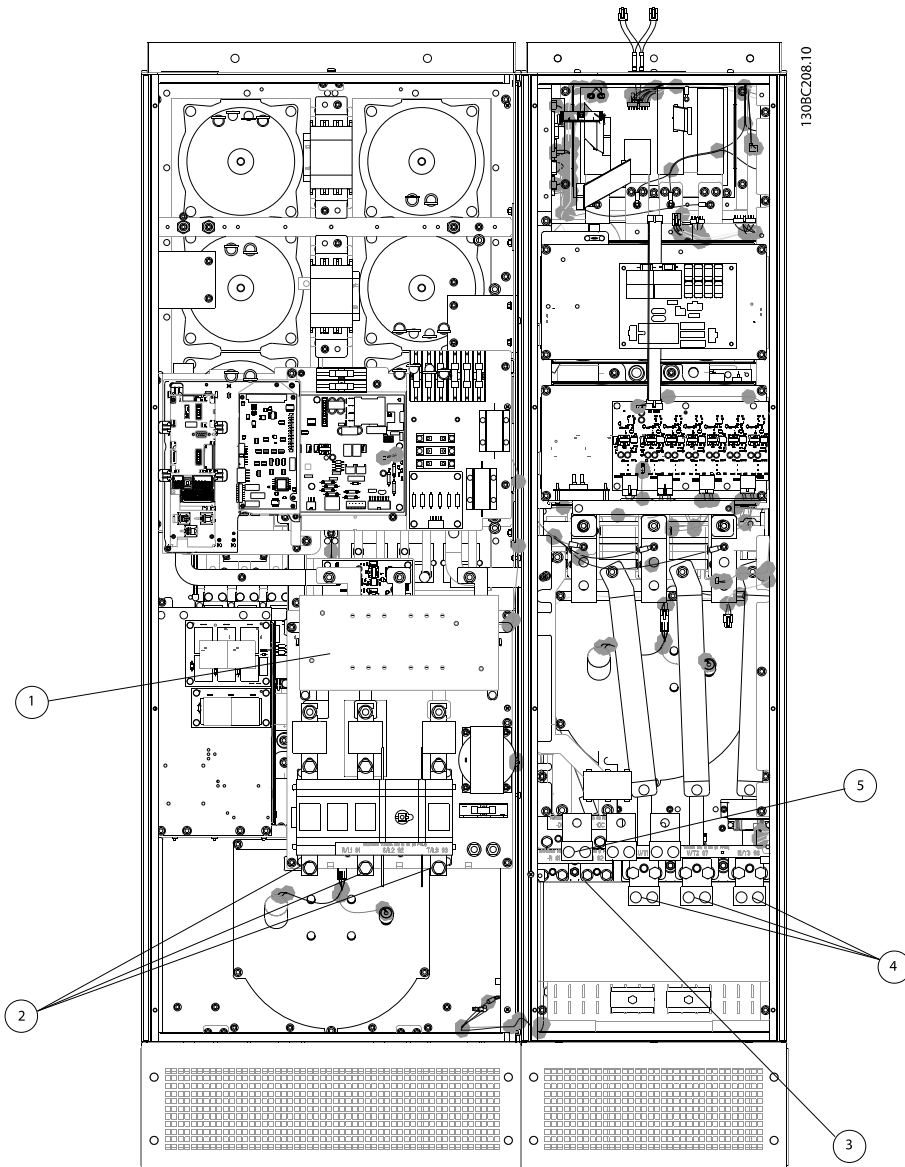

Illustration 4.25 Frame Size D13

1) RFI				4) Motor			
2) Line	R	S	T		U	V	W
	L1	L2	L3		96	97	98
3) Brake option					T1	T2	T3
	-R	+R		5) Load sharing option			
	81	82			-DC	+DC	
					88	89	
				6) AUX Fan			
					100	101	102
					L1	L2	L1
							L2

Table 4.13

4

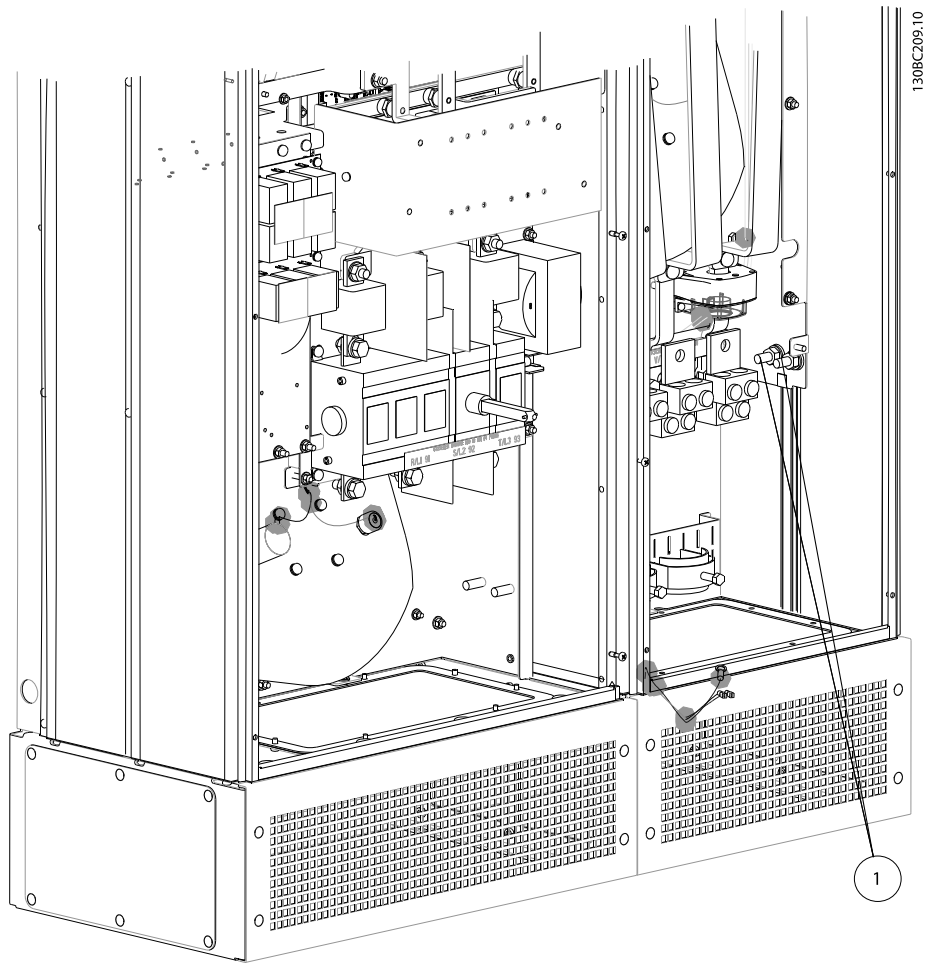
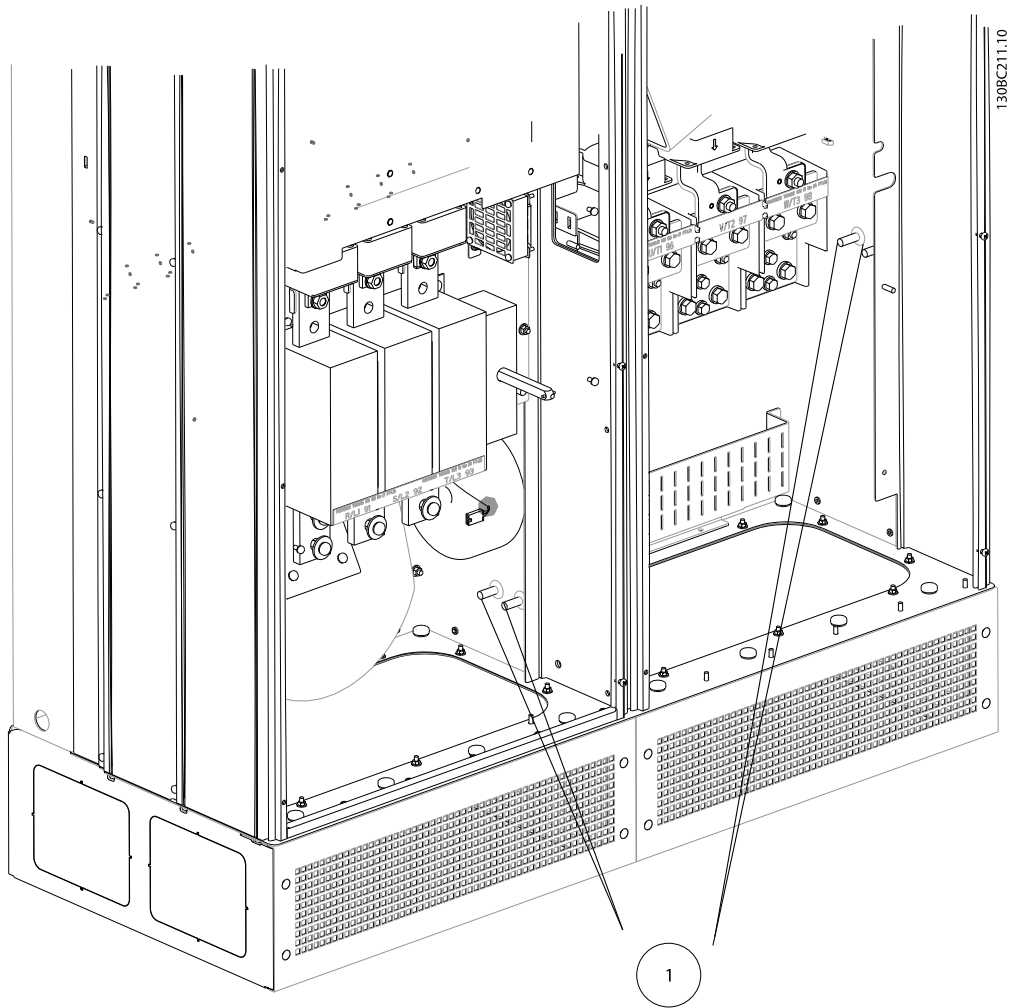

Illustration 4.26 Position of Earth Terminals

1) RFI				4) Motor			
2) Line				U	V	W	
R	S	T		96	97	98	
L1	L2	L3		T1	T2	T3	
3) Brake option				5) Load sharing option			
-R	+R			-DC	+DC		
81	82			88	89		
				6) AUX Fan			
				100	101	102	103
				L1	L2	L1	L2

Table 4.14



4

Illustration 4.27 Position of Earth Terminals

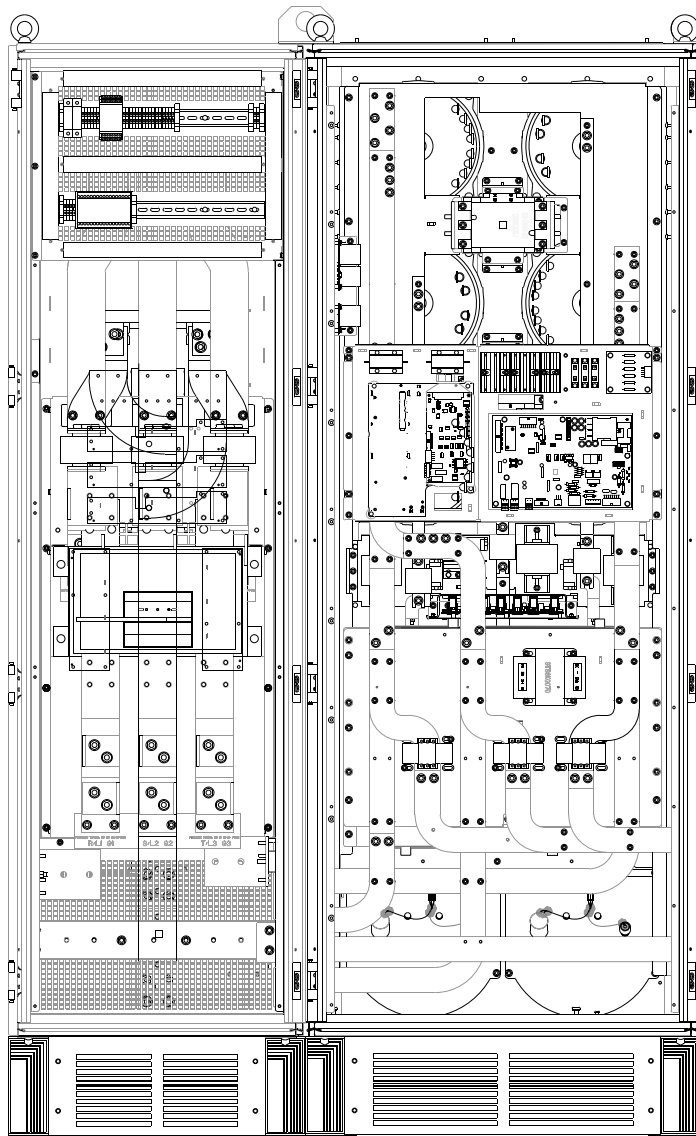

130BX443

Illustration 4.28 Active Filter,

Sections shown

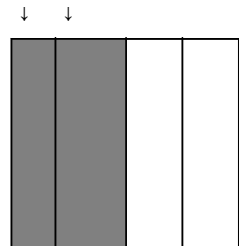

Table 4.15



How to Install

VLT® Automation VT Drive FC 322 Drive LHD for AAF006 Operating Instructions

- | | | | | |
|----|--|----|----|--|
| 1) | Line | | | |
| | R | S | T | |
| | L1 | L2 | L3 | |
| 2) | Bus bars to rectifier section of frequency converter | | | |
| 3) | Fuse block | | | |

Table 4.16

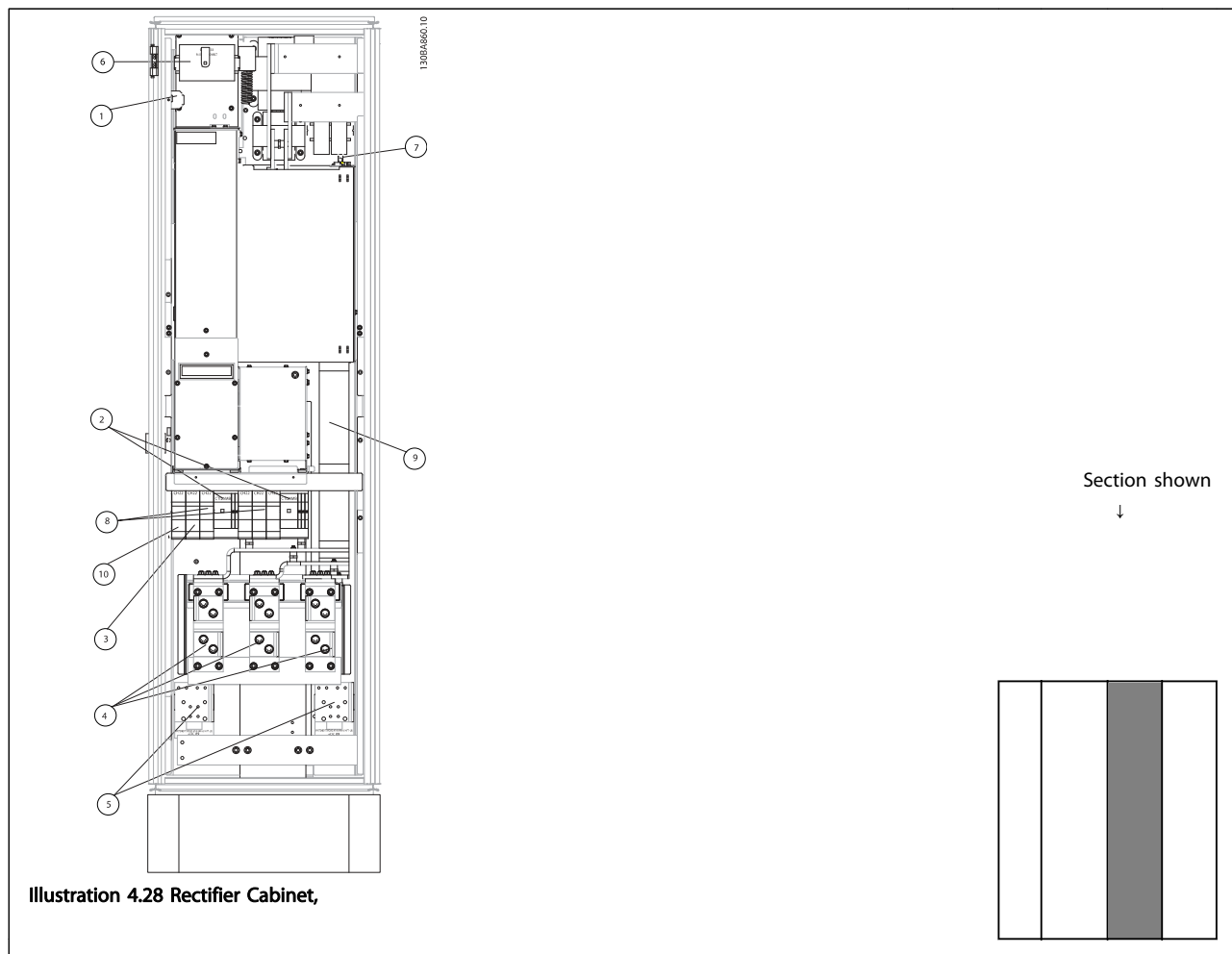

Illustration 4.28 Rectifier Cabinet,

Table 4.17

1) 24 V DC, 5 A T1 Output Taps Temp Switch 106 104 105	5) Loadsharing -DC +DC 88 89
2) Manual Motor Starters	6) Control Transformer Fuses (2 or 4 pieces). See 4.6.12 Fuses for part numbers
3) 30 A Fuse Protected Power Terminals	7) SMPS Fuse. See 4.6.12 Fuses for part numbers
4) Connection point to filter R S T L1 L2 L3	8) Manual Motor Controller fuses (3 or 6 pieces). See 4.6.12 Fuses for part numbers
	9) Line Fuses, unit sizes 61 and 62 (3 pieces). See 4.6.12 Fuses for part numbers
	10) 30 Amp Fuse Protected Power fuses

Table 4.18

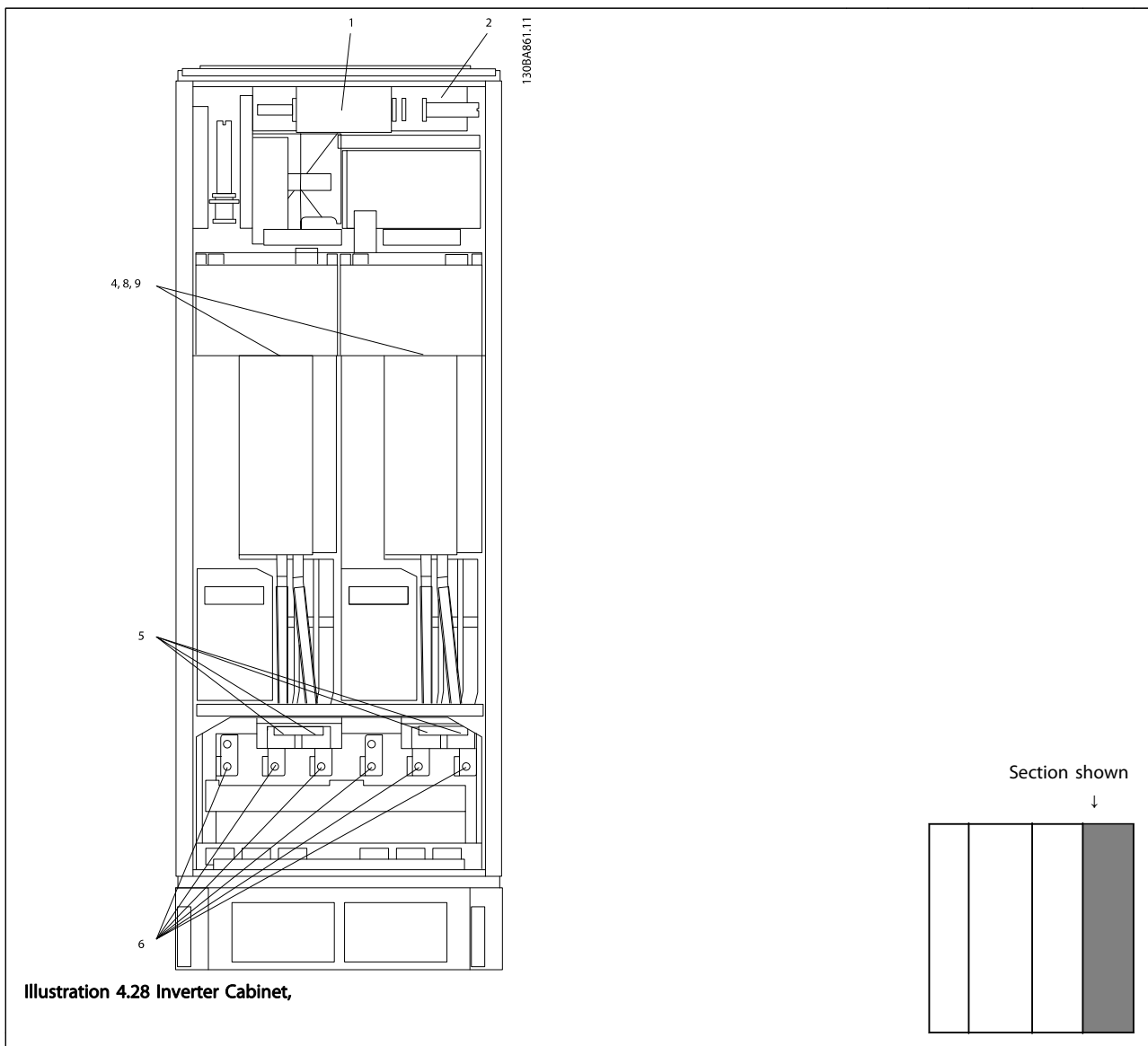

Illustration 4.28 Inverter Cabinet,

Table 4.19

1) External Temperature Monitoring	6) Motor
2) AUX Relay	U V W
01 02 03	96 97 98
04 05 06	T1 T2 T3
3) NAMUR	7) NAMUR Fuse. See 4.6.12 Fuses for part numbers
4) AUX Fan	8) Fan Fuses. See 4.6.12 Fuses for part numbers
100 101 102 103	9) SMPS Fuses. See 4.6.12 Fuses for part numbers
L1 L2 L1 L2	
5) Brake	
-R +R	
81 82	

Table 4.20

4.6.2 Earthing

The following basic issues need to be considered when installing a frequency converter, so as to obtain electro-magnetic compatibility (EMC).

- Safety earthing: Note that the frequency converter has a high leakage current and must be earthed appropriately for safety reasons. Apply local safety regulations.
- High-frequency earthing: Keep the earth wire connections as short as possible.

Connect the different earth systems at the lowest possible conductor impedance. The lowest possible conductor impedance is obtained by keeping the conductor as short as possible and by using the greatest possible surface area. The metal cabinets of the different devices are mounted on the cabinet rear plate using the lowest possible HF impedance. This avoids having different HF voltages for the individual devices and avoids the risk of radio interference currents running in connection cables that may be used between the devices. The radio interference will have been reduced.

In order to obtain a low HF impedance, use the fastening bolts of the devices as HF connection to the rear plate. It is necessary to remove insulating paint or similar from the fastening points.

4.6.3 Extra Protection (RCD)

ELCB relays, multiple protective earthing or earthing can be used as extra protection, provided that local safety regulations are complied with.

In the case of an earth fault, a DC component may develop in the fault current.

If ELCB relays are used, local regulations must be observed. Relays must be suitable for protection of 3-phase equipment with a bridge rectifier and for a brief discharge on power-up.

See also *Special Conditions* in the Design Guide, MG33BXYY.

4.6.4 Drives with Factory installed A1/B1 RFI Filter Option

Mains supply isolated from earth

If the frequency converter is supplied from an isolated mains source (IT mains, floating delta and grounded delta) or TT/TN-S mains with grounded leg, the RFI switch is recommended to be turned off (OFF) via *14-50 RFI Filter* on the frequency converter. For further reference, see IEC 364-3. In case optimum EMC performance is needed, parallel motors are connected or the motor cable length is

above 25 m, it is recommended to set *14-50 RFI Filter* to [ON].

In OFF, the internal RFI capacities (filter capacitors) between the chassis and the intermediate circuit are cut off to avoid damage to the intermediate circuit and to reduce the earth capacity currents (according to IEC 61800-3).

It is important to use isolation monitors that are capable for use together with power electronics (IEC 61557-8).

4.6.5 Torque

When tightening all electrical connections it is very important to tighten with the correct torque. Too low or too high torque results in a bad electrical connection. Use a torque wrench to ensure correct torque.

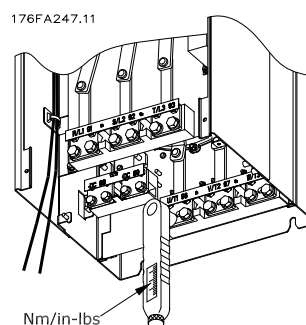

Illustration 4.28 Always Use a Torque Wrench to Tighten the Bolts.

Unit Size	Terminal	Torque	Bolt size
41, 42, 43 and 44	Mains Motor	19-40 Nm (168-354 in-lbs)	M10
51 and 52	Mains Motor	19-40 Nm (168-354 in-lbs)	M10
61, 62, 63 and 64	Mains Motor	19-40 Nm (168-354 in-lbs)	M10

Table 4.21 Torque for terminals

4.6.6 Shielded Cables

It is important that shielded and armoured cables are connected in a proper way to ensure the high EMC immunity and low emissions.

The connection can be made using either cable glands or clamps

- EMC cable glands: Generally available cable glands can be used to ensure an optimum EMC connection.
- EMC cable clamp: Clamps allowing easy connection are supplied with the frequency converter.

4.6.7 Motor Cable

The motor must be connected to terminals U/T1/96, V/T2/97, W/T3/98 located on the far right of the unit. Earth to terminal 99. All types of three-phase asynchronous standard motors can be used with a frequency converter unit. The factory setting is for clockwise rotation with the frequency converter output connected as follows:

Terminal No.	Function
96, 97, 98, 99	Mains U/T1, V/T2, W/T3 Earth

Table 4.22

- Terminal U/T1/96 connected to U-phase
- Terminal V/T2/97 connected to V-phase
- Terminal W/T3/98 connected to W-phase

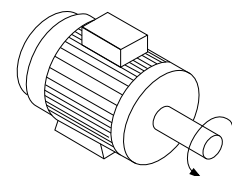
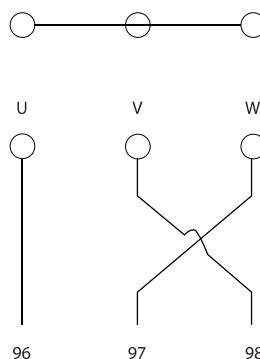
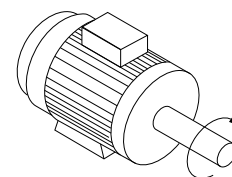
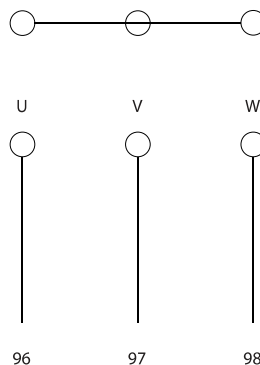

Illustration 4.29

The direction of rotation can be changed by switching two phases in the motor cable or by changing the setting of 4-10 Motor Speed Direction and reversing.

Unit Size 6X Requirements

Motor phase cable quantities must be multiples of 2, resulting in 2, 4, 6, or 8 (1 cable is not allowed) to obtain equal amount of wires attached to both inverter module terminals. The cables are required to be equal length within 10% between the inverter module terminals and the first common point of a phase. The recommended common point is the motor terminals.

Output junction box requirements

The length, minimum 2.5 m, and quantity of cables must be equal from each inverter module to the common terminal in the junction box.

4.6.8 Load Sharing

Terminal No.	Function
88, 89	Loadsharing

Table 4.23



The connection cable must be screened and the max. length from the frequency converter to the DC bar is limited to 25 m (82 ft).

Load sharing enables linking of the DC intermediate circuits of several frequency converters.

⚠ WARNING

Note that voltages up to 1099 V DC may occur on the terminals.

Load Sharing calls for extra equipment and safety considerations. For further information, please contact GE.

⚠ WARNING

Note that mains disconnect may not isolate the frequency converter due to DC link connection

NOTE

Please consult GE for ordering.

4.6.9 Mains Connection

Mains must be connected to terminals 91, 92 and 93 located on the far left of the unit. Earth is connected to the terminal to the right of terminal 93.

Terminal No.	Function
91, 92, 93	Mains R/L1, S/L2, T/L3
94	Earth

Table 4.24

NOTE

Check the name plate to ensure that the mains voltage of the frequency converter matches the power supply of the plant.

Ensure that the power supply can supply the necessary current to the frequency converter.

4.6.10 External Fan Supply

In case the frequency converter is supplied by DC or if the fan must run independently of the power supply, an external power supply can be applied. The connection is made on the power card.

Terminal No.	Function
100, 101	Auxiliary supply S, T
102, 103	Internal supply S, T

Table 4.25

The connector located on the power card provides the connection of line voltage for the cooling fans. The fans are connected from factory to be supplied from a common

AC line (jumpers between 100-102 and 101-103). If external supply is needed, the jumpers are removed and the supply is connected to terminals 100 and 101. A 5 Amp fuse should be used for protection. In UL applications this should be LittleFuse KLK-5 or equivalent.

4.6.11 Power and Control Wiring for Unscreened Cables

⚠ WARNING

Induced Voltage!

Run motor cables from multiple drives separately. Induced voltage from output motor cables run together can charge equipment capacitors even with the equipment turned off and locked out. Failure to run output cables separately could result in death or serious injury.

⚠ WARNING

Run drive input power, motor wiring, and control wiring in three separate metallic conduits or raceways for high frequency noise isolation. Failure to isolate power, motor, and control wiring could result in less than optimum controller and associated equipment performance.

Because the power wiring carries high frequency electrical pulses, it is important that input power and motor power are run in separate conduit. If the incoming power wiring is run in the same conduit as the motor wiring, these pulses can couple electrical noise back onto the building power grid. Control wiring should always be isolated from the high voltage power wiring.

When screened/armoured cable is not used, at least three separate conduits must be connected to the panel option.



- Power wiring into the enclosure
- Power wiring from the enclosure to the motor
- Control wiring

The frequency converter provides overload protection to limit threats to human life, property damage and to avoid fire hazard due to overheating of the cables in the installation. The frequency converter is equipped with an internal over current protection (*4-18 Current Limit*) that can be used for upstream overload protection (UL-applications excluded). Moreover, fuses or Circuit Breakers can be used to provide the over current protection in the installation. Over current protection must always be carried out according to national regulations.

4.6.12 Fuses

It is recommended to use fuses and/or circuit breakers on the supply side as protection in case of component break-down inside the frequency converter (first fault).

NOTE

This is mandatory in order to ensure compliance with IEC 60364 for CE or NEC 2009 for UL.

⚠WARNING

Personnel and property must be protected against the consequence of component break-down internally in the frequency converter.

Branch circuit protection

In order to protect the installation against electrical and fire hazard, all branch circuits in an installation, switch gear, machines etc., must be protected against short-circuit and over-current according to national/international regulations.

NOTE

The recommendations given do not cover Branch circuit protection for UL.

Short-circuit protection:

Danfoss recommends using the fuses/circuit breakers mentioned below to protect service personnel and property in case of component break-down in the frequency converter.

Over current protection:

⚠WARNING

In case of malfunction, not following the recommendation may result in personnel risk and damage to the frequency converter and other equipment.

The following tables list the recommended rated current. Recommended fuses are of the type gG for small to medium power sizes. For larger powers, aR fuses are recommended. Circuit breakers must be used provided they meet the national/international regulations and they limit the energy into the frequency converter to an equal or lower level than the compliant circuit breakers. If fuses/Circuit Breakers according to recommendations are chosen, possible damages on the frequency converter will mainly be limited to damages inside the unit.

4.6.13 Fuse Specifications

UL compliance

380-480 V, frame sizes 4X, 5X and 6X

The fuses below are suitable for use on a circuit capable of delivering 100,000 Arms (symmetrical), 240 V, or 480 V, or 500 V, or 600 V depending on the frequency converter voltage rating. With the proper fusing the frequency converter Short Circuit Current Rating (SCCR) is 100,000 Arms.

AF-600 FP	Bussmann E1958 JFHR2**	Bussmann E4273 T/JDDZ**	SIBA E180276 JFHR2	LittelFuse E91611 JFHR2**	Ferraz- Shawmut E60314 JFHR2**	Bussmann E4274 H/JDDZ**	Bussmann E125085 JFHR2*	Internal Option Bussmann
250 HP	FWH- 400	JJS- 400	2061032.40	L50S-400	A50-P400	NOS- 400	170M4012	170M4016
300 HP	FWH- 500	JJS- 500	2061032.50	L50S-500	A50-P500	NOS- 500	170M4014	170M4016
350 HP	FWH- 600	JJS- 600	2062032.63	L50S-600	A50-P600	NOS- 600	170M4016	170M4016

Table 4.26 For Unit Sizes 41, 42, 43, and 44, 380-480 V



How to Install

VLT® Automation VT Drive FC 322 Drive LHD for AAF006 Operating Instructions

AF-600 FP	Bussmann PN*	Rating	Ferraz	Siba
450 HP	170M4017	700 A, 700 V	6.9URD31D08A0700	20 610 32.700
500 HP	170M6013	900 A, 700 V	6.9URD33D08A0900	20 630 32.900
550 HP	170M6013	900 A, 700 V	6.9URD33D08A0900	20 630 32.900
600 HP	170M6013	900 A, 700 V	6.9URD33D08A0900	20 630 32.900

Table 4.27 For Unit Sizes 51 and 52, 380-480 V

AF-600 FP	Bussmann PN*	Rating	Siba	Internal Bussmann Option
650 HP	170M7081	1600 A, 700 V	20 695 32.1600	170M7082
750 HP	170M7081	1600 A, 700 V	20 695 32.1600	170M7082
900 HP	170M7082	2000 A, 700 V	20 695 32.2000	170M7082
1000 HP	170M7082	2000 A, 700 V	20 695 32.2000	170M7082

Table 4.28 Unit Sizes 61, 62, 63, and 64, 380-480 V

AF-600 GP	Bussmann PN*	Rating	Siba
650 HP	170M8611	1100 A, 1000 V	20 781 32.1000
750 HP	170M8611	1100 A, 1000 V	20 781 32.1000
900 HP	170M6467	1400 A, 700 V	20 681 32.1400
1000 HP	170M6467	1400 A, 700 V	20 681 32.1400

Table 4.29 Unit Sizes 61, 62, 63, and 64, Inverter module DC Link Fuses, 380-480 V

*170M fuses from Bussmann shown use the -/80 visual indicator, - TN/80 Type T, -/110 or TN/110 Type T indicator fuses of the same size and amperage may be substituted for external use

**Any minimum 500 V UL listed fuse with associated current rating may be used to meet UL requirements.

Supplementary fuses

Unit Sizes	Bussmann PN*	Rating
4X, 5X and 6X	KTK-4	4 A, 600 V

Table 4.30 SMPS Fuse

Size/Type	Bussmann PN*	Littelfuse	Rating
150HP-450HP, 380-480 V	KTK-4		4 A, 600 V
500HP-1350HP, 380-480 V		KLK-15	15A, 600 V

Table 4.31 Fan Fuses

Size/Type		Bussmann PN*	Rating	Alternative Fuses
650HP-1350HP, 380-480 V	2.5-4.0 A	LPJ-6 SP or SPI	6 A, 600 V	Any listed Class J Dual Element, Time Delay, 6A
650HP-1350HP, 380-480 V	4.0-6.3 A	LPJ-10 SP or SPI	10 A, 600 V	Any listed Class J Dual Element, Time Delay, 10 A
650HP-1350HP, 380-480 V	6.3 - 10 A	LPJ-15 SP or SPI	15 A, 600 V	Any listed Class J Dual Element, Time Delay, 15 A
650HP-1350HP, 380-480 V	10 - 16 A	LPJ-25 SP or SPI	25 A, 600 V	Any listed Class J Dual Element, Time Delay, 25 A

Table 4.32 Manual Motor Controller Fuses

Unit Sizes	Bussmann PN*	Rating	Alternative Fuses
6X	LPJ-30 SP or SPI	30 A, 600 V	Any listed Class J Dual Element, Time Delay, 30 A

Table 4.33 30 A Fuse Protected Terminal Fuse



How to Install

VLT® Automation VT Drive FC 322 Drive LHD for AAF006 Operating Instructions

Unit Sizes	Bussmann PN*	Rating	Alternative Fuses
D	LP-CC-8/10	0.8A, 600V	Any listed Class CC, 0.8A
E	LP-CC-1 1/2	1.5A, 600V	Any listed Class CC, 1.5A
6X	LPJ-6 SP or SPI	6 A, 600 V	Any listed Class J Dual Element, Time Delay, 6 A

Table 4.34 Control Transformer Fuse

Unit Sizes	Bussmann PN*	Rating
6X	GMC-800MA	800 mA, 250 V

Table 4.35 NAMUR Fuse

Unit Sizes	Bussmann PN*	Rating	Alternative Fuses
6X	LP-CC-6	6 A, 600 V	Any listed Class CC, 6 A

Table 4.36 Safety Relay Coil Fuse with PILZ Relay

4.6.14 Motor Insulation

For motor cable lengths \leq the maximum cable length listed in *8 General Specifications* the following motor insulation ratings are recommended because the peak voltage can be up to twice the DC link voltage, 2.8 times the mains voltage, due to transmission line effects in the motor cable. If a motor has lower insulation rating it is recommended to use a dU/dt or sine wave filter.

Nominal Mains Voltage	Motor Insulation
$U_N \leq 420$ V	Standard $U_{LL} = 1300$ V
420 V $< U_N \leq 500$ V	Reinforced $U_{LL} = 1600$ V

Table 4.37

4.6.15 Motor Bearing Currents

It is recommended that motors of a rating 110 kW or higher operating via frequency converters should have NDE (Non-Drive End) insulated bearings installed to eliminate circulating bearing currents due to the physical size of the motor. To minimize DE (Drive End) bearing and shaft currents proper grounding of the frequency converter, motor, driven machine, and motor to the driven machine is required. Although failure due to bearing currents is low and dependent on many different items, for security of operation the following are mitigation strategies which can be implemented.

Standard mitigation strategies

1. Use an insulated bearing
2. Apply rigorous installation procedures
 - Ensure the motor and load motor are aligned
 - Strictly follow the EMC Installation guideline

Reinforce the PE so the high frequency impedance is lower in the PE than the input power leads

Provide a good high frequency connection between the motor and the frequency converter for instance by screened cable which has a 360° connection in the motor and the frequency converter

Make sure that the impedance from frequency converter to building ground is lower than the grounding impedance of the machine. This can be difficult for pumps- Make a direct earth connection between the motor and load motor.

3. Apply conductive lubrication
4. Try to ensure that the line voltage is balanced to ground. This can be difficult for IT, TT, TN-CS or Grounded leg systems
5. Use an insulated bearing as recommended by the motor manufacturer

NOTE

Motors from reputable manufacturers will typically have these fitted as standard in motors of this size.

If found to be necessary and after consultation with Danfoss:

6. Lower the IGBT switching frequency
7. Modify the inverter waveform, 60° AVM vs. SFAVM
8. Install a shaft grounding system or use an isolating coupling between motor and load
9. Use minimum speed settings if possible
10. Use a dU/dt or sinus filter

4.6.16 Control Cable Routing

Tie down all control wires to the designated control cable routing as shown in the picture. Remember to connect the shields in a proper way to ensure optimum electrical immunity.

Field Installed Network Module options connection

Connections are made to the network options on the control card. For details, see the relevant network instructions. The cable must be placed in the provided path inside the frequency converter and tied down together with other control wires (see *Illustration 4.30* and *Illustration 4.31*).

4

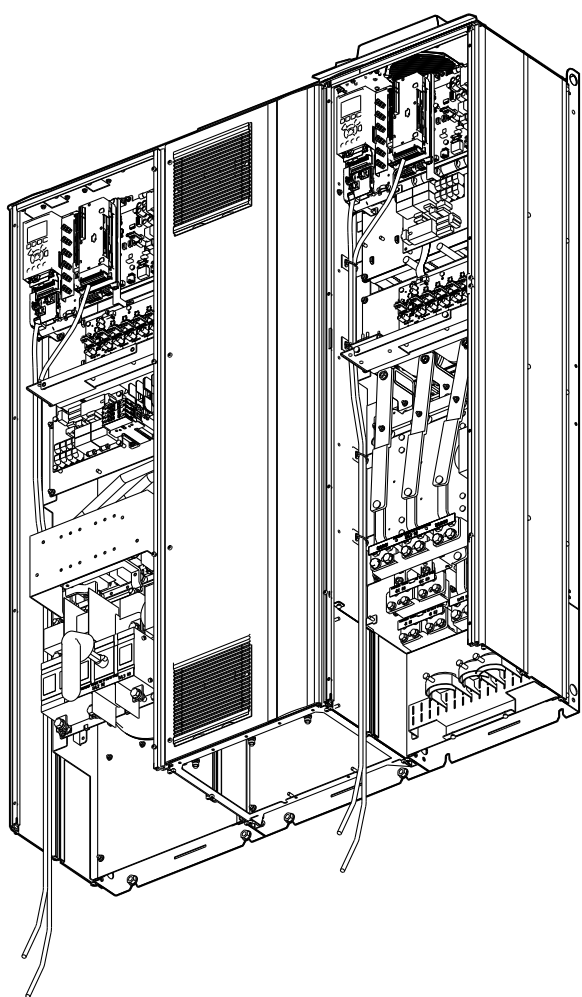

Illustration 4.30 Control Card Wiring Path for the D13

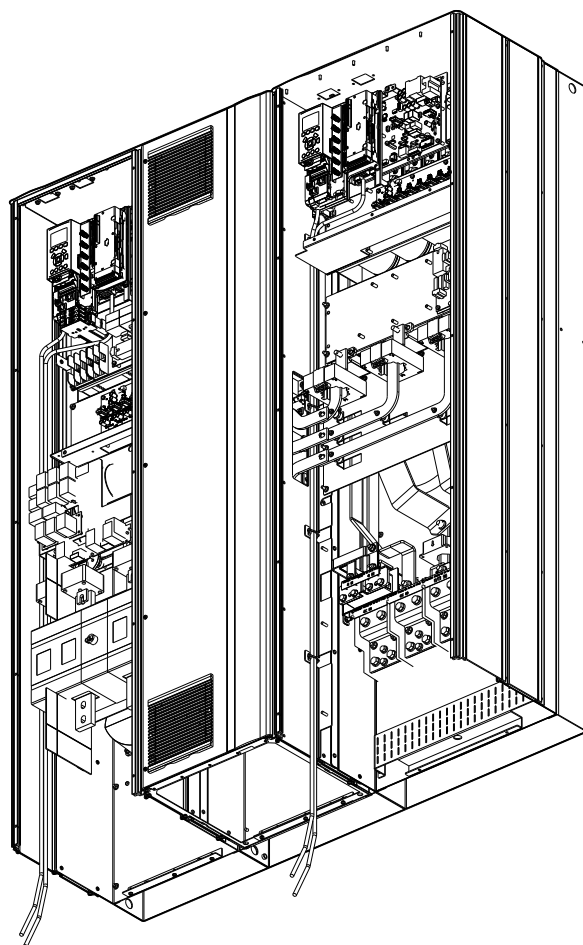

Illustration 4.31 Control Card Wiring Path for the E9

4.6.17 Access to Control Terminals

All terminals to the control cables are located beneath the LCP (both filter and frequency converter LCP). They are accessed by opening the door of the unit.

4.6.18 Electrical Installation, Control Terminals

To connect the cable to the terminal

1. Strip insulation by about 9-10 mm

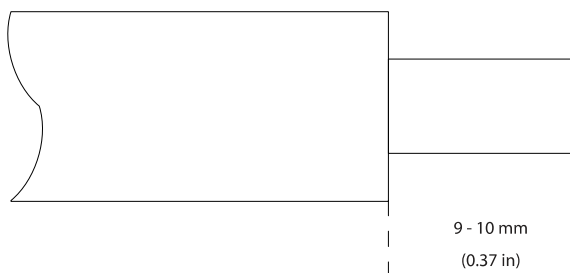

Illustration 4.32

2. Insert a screwdriver¹⁾ in the square hole.
3. Insert the cable in the adjacent circular hole.

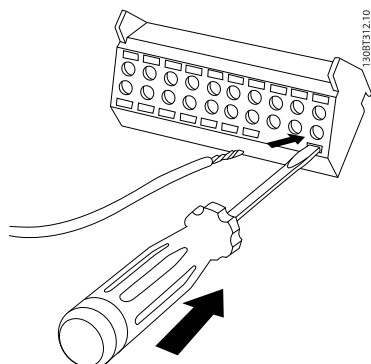

Illustration 4.33

4. Remove the screwdriver. The cable is now mounted in the terminal.

To remove the cable from the terminal

1. Insert a screw driver¹⁾ in the square hole.
2. Pull out the cable.

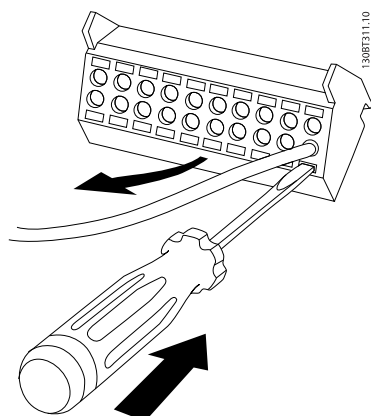

Illustration 4.34

¹⁾ Max. 0.4 x 2.5 mm

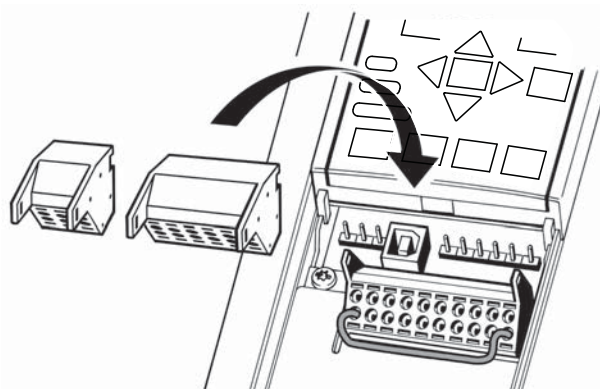

Illustration 4.35

4.7 Connection Examples for Control of Motor with External Signal Provider

NOTE

The following examples refer only to the frequency converter control card (right LCP), *not* the filter.

4.7.1 Start/Stop

Terminal 18 = 5-10 Terminal 18 Digital Input [8] Start

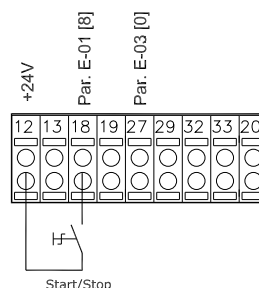

130BA155.13

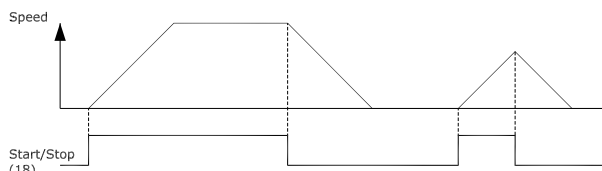

Illustration 4.36

4.7.2 Pulse Start/Stop

Terminal 18 = 5-10 Terminal 18 Digital Input [9] Latched start

Terminal 27= 5-12 Terminal 27 Digital Input [6] Stop inverse

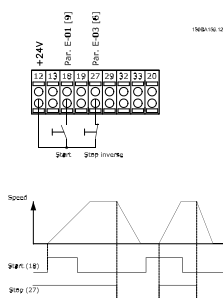

Illustration 4.37

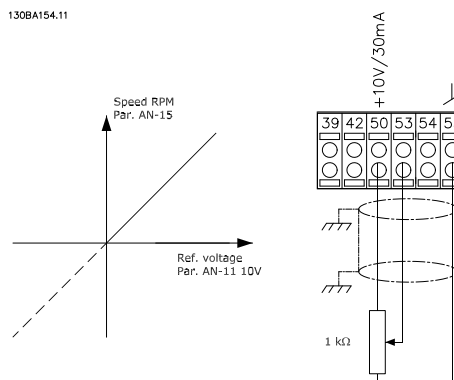

Illustration 4.39

4.7.3 Speed Up/Down

Terminals 29/32 = Speed up/down

Terminal 18 = 5-10 Terminal 18 Digital Input Start [9] (default)

Terminal 27 = 5-12 Terminal 27 Digital Input Freeze reference [19]

Terminal 29 = 5-13 Terminal 29 Digital Input Speed up [21]

Terminal 32 = 5-14 Terminal 32 Digital Input Speed down [22]

NOTE

Terminal 29 only in FC x02 (x=series type).

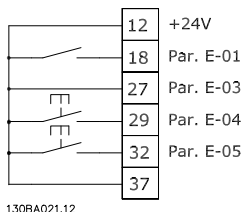

Illustration 4.38

4.7.4 Potentiometer Reference

Voltage reference via a potentiometer

Reference Source 1 = [1] Analog input 53 (default)

Terminal 53, Low Voltage = 0 V

Terminal 53, High Voltage = 10 V

Terminal 53, Low Ref./Feedback = 0 RPM

Terminal 53, High Ref./Feedback = 1500 RPM

Switch S201 = OFF (U)

4.8 Electrical Installation - Additional

4.8.1 Electrical Installation, Control Cables

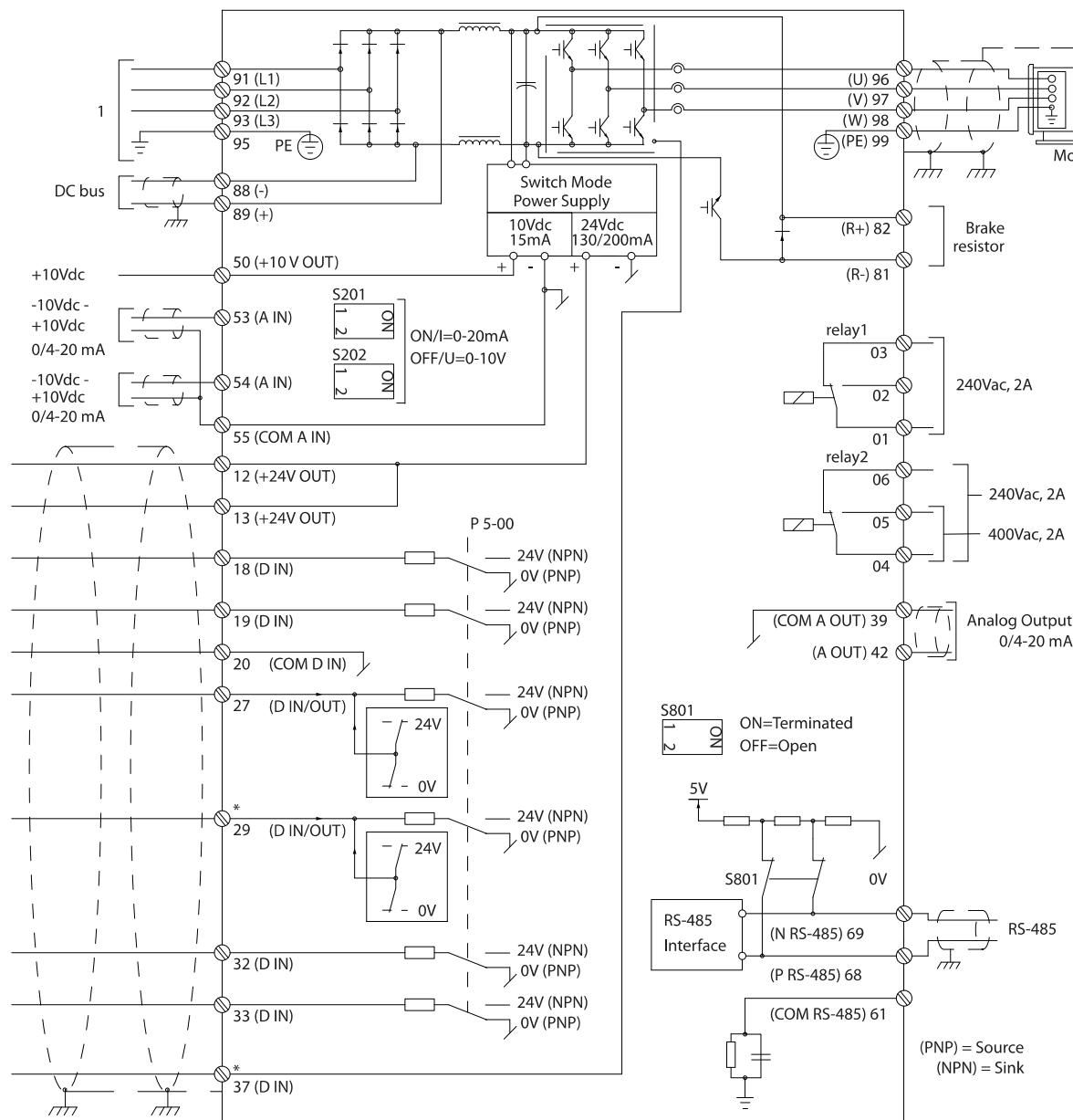

Illustration 4.40 Diagram showing all electrical terminals without options.

1: Connection to filter

Very long control cables and analogue signals may in rare cases and depending on installation result in 50/60 Hz earth loops due to noise from mains supply cables.

If this occurs, it may be necessary to break the screen or insert a 100 nF capacitor between screen and chassis.

The digital and analog inputs and outputs must be connected separately to the control cards of the unit (both filter and frequency converter, terminal 20, 55, 39) to avoid

earth currents from both groups to affect other groups. For example, switching on the digital input may disturb the analog input signal.

Input polarity of control terminals

4

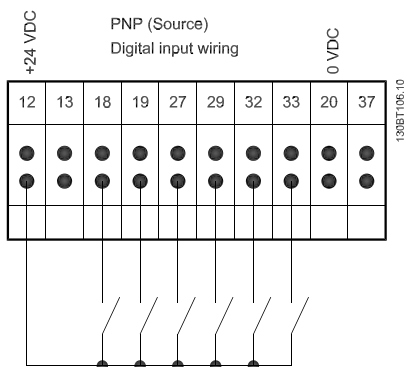

Illustration 4.41

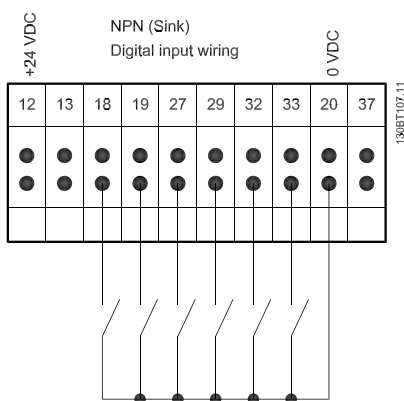

Illustration 4.42

NOTE

. If unscreened control cables are used, it is recommended to use ferrite cores to improve EMC performance.

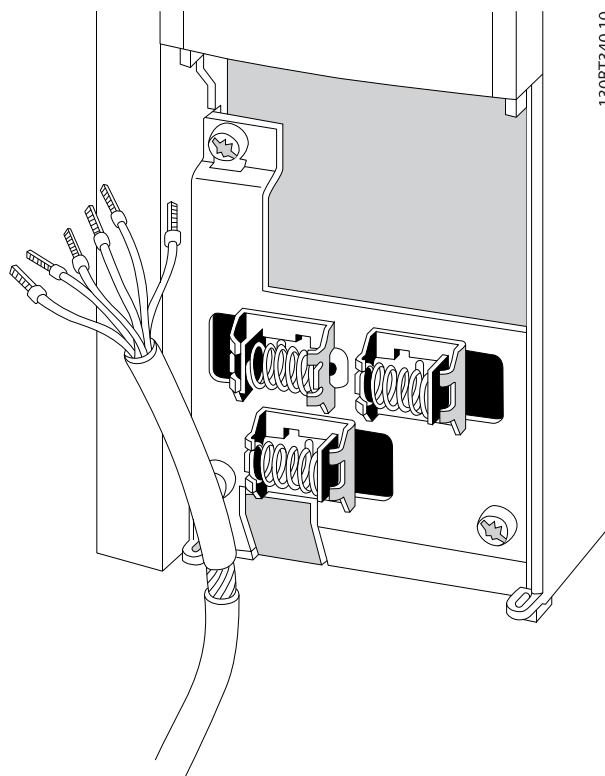

Illustration 4.43

Connect the wires as described in the Operating Instruction for the frequency converter. Remember to connect the shields in a proper way to ensure optimum electrical immunity.

4.8.2 Switches S201, S202, and S801

Switches S201 (A53) and S202 (A54) are used to select a current (0-20 mA) or a voltage (-10 to +10 V) configuration of the analog input terminals 53 and 54 respectively.

Switch S801 (BUS TER.) can be used to enable termination on the RS-485 port (terminals 68 and 69).

See *Illustration 4.40*.

Default setting:

S201 (A53) = OFF (voltage input)

S202 (A54) = OFF (voltage input)

S801 (Bus termination) = OFF

NOTE

When changing the function of S201, S202 or S801 be careful not to use force for the switch over. It is recommended to remove the LCP fixture (cradle) when operating the switches. The switches must not be operated with power on the frequency converter.

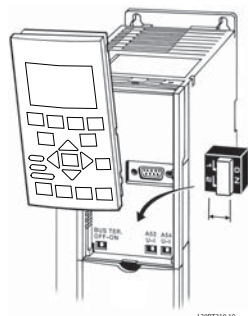
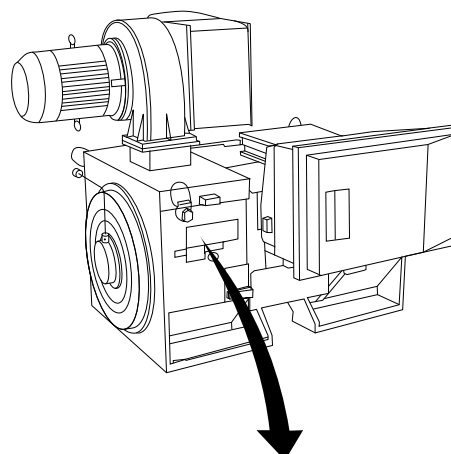

Illustration 4.44



130BA767.10

THREE PHASE INDUCTION MOTOR				
MOD MCV 315E	Nr.	135189 12 04		IL/IN 6.5
kW 400		PRIMARY		SF 1.15
HP 536	V 690	A 410.6	CONN Y	COS f 0.85 40
mm 1481	V	A	CONN	AMB 40 °C
Hz 50	V	A	CONN	ALT 1000 m
DESIGNN	SECONDARY			RISE 80 °C
DUTY S1	V	A	CONN	ENCLOSURE IP23
INSUL I	EFFICIENCY %	95.8%	100%	95.8% 75% WEIGHT 1.83 ton

CAUTION

Illustration 4.45

4.9 Final Set-up and Test

To test the set-up and ensure that the frequency converter is running, follow these steps.

Step 1. Locate the motor name plate

NOTE

The motor is either star- (Y) or delta- connected (Δ). This information is located on the motor name plate data.

Step 2. Enter the motor name plate data in this parameter list.

To access this list first press [Quick Menu] then select . Use the up and down arrow keys to navigate to the parameters associated with the motor nameplate values.

1.	1-20 Motor Power [kW] 1-21 Motor Power [HP]
2.	1-22 Motor Voltage
3.	1-23 Motor Frequency
4.	1-24 Motor Current
5.	1-25 Motor Nominal Speed

Table 4.38

Step 3. Activate the Auto tune

Performing an auto tune will ensure optimum performance. The auto tune measures the values from the motor model equivalent diagram.

1. Activate the auto tune 1-29 Automatic Motor Adaptation (AMA).
2. Choose between complete or reduced auto tune. If a Sine-wave filter is mounted, run only the reduced auto tune, or remove the Sine-wave filter and run complete Auto Tune.
3. Press [OK]. The display shows "Press [Hand] to start".

4. Press [Hand]. A progress bar indicates if the auto tune is in progress.

Stop the auto tune during operation

1. Press [Off] - the frequency converter enters into alarm mode and the display shows that the auto tune was terminated by the user.

Successful auto tune

1. The display shows "Press [OK] to finish auto tune".
2. Press [OK] to exit the auto tune state.

Unsuccessful auto tune

1. The frequency converter enters into alarm mode. A description of the alarm can be found in *9 Troubleshooting*.
2. "Report Value" in the [Alarm Log] shows the last measuring sequence carried out by the auto tune, before the frequency converter entered alarm mode. This number along with the description of the alarm assists in troubleshooting. If contacting Danfoss for service, make sure to mention number and alarm description.

NOTE

Unsuccessful auto tune is often caused by incorrectly entering motor name plate data or a too big difference between the motor power size and the frequency converter power size.

Step 4. Set speed limit and accel/decel times.

3-02 Minimum Reference

3-03 Maximum Reference

Set up the desired limits for speed and ramp time

4-11 Motor Speed Low Limit [RPM] or 4-12 Motor Speed Low Limit [Hz]

4-13 Motor Speed High Limit [RPM] or 4-14 Motor Speed High Limit [Hz]

3-41 Ramp 1 Ramp Up Time

3-42 Ramp 1 Ramp Down Time

4.10 Additional Connections

4.10.1 Parallel Connection of Motors

The frequency converter can control several parallel-connected motors. The total current consumption of the motors must not exceed the rated output current $I_{M,N}$ for the frequency converter.

NOTE

Installations with cables connected in a common joint as in *Illustration 4.46*, is only recommended for short cable lengths.

NOTE

When motors are connected in parallel, *1-29 Automatic Motor Adaptation (AMA)* cannot be used.

NOTE

The electronic thermal overload of the frequency converter cannot be used as motor protection for the individual motor in systems with parallel-connected motors. Provide further motor protection by e.g. thermistors in each motor or individual thermal relays (circuit breakers are not suitable as protection).

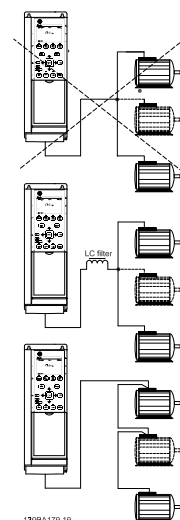

Illustration 4.46

Problems may arise at start and at low RPM values if motor sizes are widely different because small motors' relatively high ohmic resistance in the stator calls for a higher voltage at start and at low RPM values.

5 How to Operate the Low Harmonic Drive

5.1.1 Ways of Operation

The Low Harmonic Drive can be operated in 2 ways:

1. Graphical Local Control Panel (GLCP)
2. RS-485 serial communication or USB, both for PC connection

5.1.2 How to Operate Graphical LCP (GLCP)

The Low Harmonic Drive is equipped with two LCPs, one on the frequency converter section (to the right) of the drive and one on the active filter section (to the left). The filter LCP is operated the same way as the frequency converter LCP. Each LCP controls only the unit it is connected to and there is no communication between the two LCPs.

NOTE

The active filter should be in Auto Mode, i.e. the [Auto On] key must be pressed on the filter LCP.

The following instructions are valid for the GLCP (LCP 102).

The GLCP is divided into four functional groups:

1. Graphical display with Status lines.
2. Menu keys and indicator lights (LEDs) - selecting mode, changing parameters and switching between display functions.
3. Navigation keys and indicator lights (LEDs).
4. Operation keys and indicator lights (LEDs).

Graphical display:

The LCD-display is back-lit with a total of 6 alpha-numeric lines. All data is displayed on the LCP which can show up to five operating variables while in [Status] mode.

Illustration 5.1 shows an example of the frequency converter LCP. The filter LCP looks identical but displays information related to the filter operation.

Display lines:

- a. **Status line:** Status messages displaying icons and graphics.
- b. **Line 1-2:** Operator data lines displaying data and variables defined or chosen by the user. By pressing the [Status] key, up to one extra line can be added.
- c. **Status line:** Status messages displaying text.

The display is divided into 3 sections:

Top section (a)

shows the status when in status mode or up to 2 variables when not in status mode and in the case of Alarm/Warning.

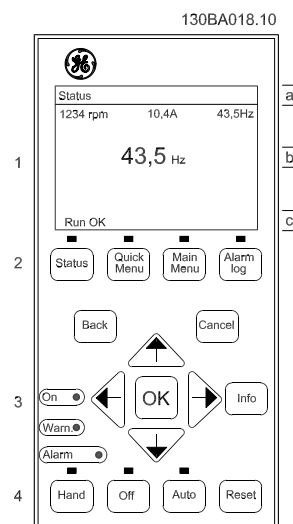

Illustration 5.1 Keypad

The number of the Active Set-up (selected as the Active Set-up in 0-10 Active Set-up) is shown. When programming in another Set-up than the Active Set-up, the number of the Set-up being programmed appears to the right in brackets.

Middle section (b)

shows up to 5 variables with related unit, regardless of status. In case of alarm/warning, the warning is shown instead of the variables.

It is possible to toggle between three status read-out displays by pressing [Status].

Operating variables with different formatting are shown in each status screen - see below.

Several values or measurements can be linked to each of the displayed operating variables. The values/measurements to be displayed can be defined via parameters 0-20, 0-21, 0-22, 0-23, and 0-24.

Each value/measurement readout parameter selected in parameters 0-20 to 0-24 has its own scale and number of digits after a possible decimal point. Larger numeric values are displayed with few digits after the decimal point.
Ex.: Current readout

5.25 A; 15.2 A 105 A.

Status display I

This read-out state is standard after start-up or initialization.

Press [Info] to obtain information about the value/measurement linked to the displayed operating variables (1.1, 1.2, 1.3, 2, and 3).

See the operating variables shown in the display in *Illustration 5.2*. 1.1, 1.2 and 1.3 are shown in small size. 2 and 3 are shown in medium size.

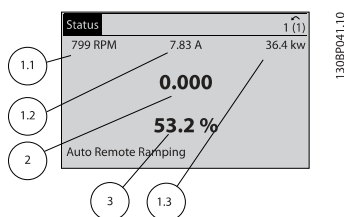

Illustration 5.2 Status Display I - Operating Variables

Status display II

See the operating variables (1.1, 1.2, 1.3, and 2) shown in the display in *Illustration 5.3*.

In the example, Speed, Motor current, Motor power and Frequency are selected as variables in the first and second lines.

1.1, 1.2 and 1.3 are shown in small size. 2 is shown in large size.

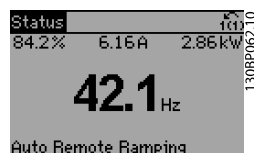

Illustration 5.3 Status Display II - Operating Variables

Status display III:

This state displays the event and action of the Smart Logic Control. For further information, see section *Smart Logic Control*.

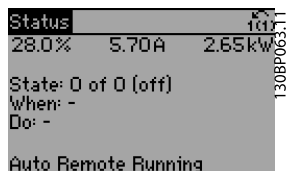

Illustration 5.4 Status Display III - Operating Variables

NOTE

Status display III is not available on the filter LCP.

Bottom section

always shows the state of the frequency converter in Status mode.

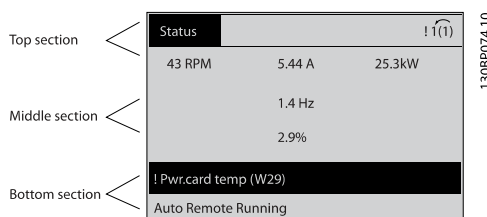

Illustration 5.5

Display contrast adjustment

Press [status] and [▲] for darker display

Press [Status] and [▼] for brighter display

Indicator lights (LEDs):

If certain threshold values are exceeded, the alarm and/or warning LED lights up. A status and alarm text appear on the control panel.

The On LED is activated when the frequency converter receives power from mains voltage, a DC bus terminal, or an external 24 V supply. At the same time, the back light is on.

- Green LED/On: Control section is working.
- Yellow LED/Warn.: Indicates a warning.
- Flashing Red LED/Alarm: Indicates an alarm.



Illustration 5.6

GLCP keys

Menu keys

The menu keys are divided into functions. The keys below the display and indicator lamps are used for parameter set-up, including choice of display indication during normal operation.



Illustration 5.7

[Status]

Indicates the status of the frequency converter (and/or the motor) or the filter respectively. On the drive LCP, 3 different readouts can be chosen by pressing the [Status] key:

- 5 line readouts, 4 line readouts or Smart Logic Control. Smart Logic Control is not available for the filter.
- Use [Status] for selecting the mode of display or for changing back to Display mode from either the Quick Menu mode, the Main Menu mode or Alarm mode. Also use the [Status] key to toggle single or double read-out mode.

[Quick Menu]

Allows quick set-up of the frequency converter or the filter. The most common functions can be programmed here.

The [Quick Menu] consists of:

- Q1: My Personal Menu
- Q2: Quick Setup
- Q5: Changes Made
- Q6: Loggings

Since the active filter is an integrated part of the Low Harmonic Drive only a minimum of programming is necessary. The filter LCP is mainly used to display information about filter operation such as THD of voltage or current, corrected current, injected current or Cos φ and True Power Factor.

The Quick Menu parameters can be accessed immediately unless a password has been created via parameters 0-60, 0-61, 0-65 or 0-66.

It is possible to switch directly between Quick Menu mode and Main Menu mode.

[Main Menu]

is used for programming all parameters.

The Main Menu parameters can be accessed immediately unless a password has been created via parameters 0-60, 0-61, 0-65 or 0-66.

It is possible to switch directly between Main Menu mode and Quick Menu mode.

Parameter shortcut can be carried out by pressing down the [Main Menu] key for 3 seconds. The parameter shortcut allows direct access to any parameter.

[Alarm Log]

displays an Alarm list of the five latest alarms (numbered A1-A5). To obtain additional details about an alarm, use the arrow keys to manoeuvre to the alarm number and press [OK]. Information is displayed about the condition of the frequency converter or filter before it enters the alarm mode.

[Back]

reverts to the previous step or layer in the navigation structure.



Illustration 5.8

[Cancel]

last change or command will be cancelled as long as the display has not been changed.



Illustration 5.9

[Info]

displays information about a command, parameter, or function in any display window. [Info] provides detailed information when needed. Exit Info mode by pressing either [Info], [Back], or [Cancel].



Illustration 5.10

Navigation keys

The four navigation keys are used to navigate between the different choices available in [Quick Menu], [Main Menu] and [Alarm Log]. Use the keys to move the cursor.

[OK]

is used for choosing a parameter marked by the cursor and for enabling the change of a parameter.

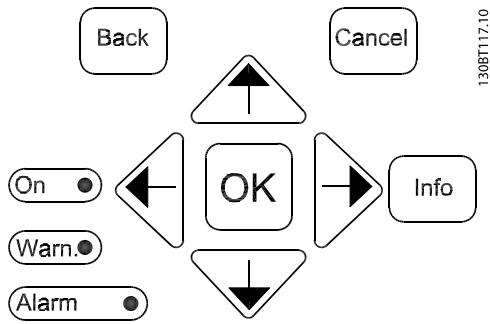

Illustration 5.11

5

Operation keys

for local control are found at the bottom of the control panel.

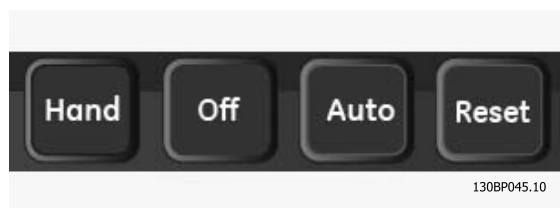

Illustration 5.12

[Hand On]

enables control of the frequency converter via the GLCP. [Hand On] also starts the motor, and it is now possible to give the motor speed reference by means of the arrow keys. The key can be [1] Enabled or [0] Disabled via 0-40 [Hand on] Key on LCP.

The following control signals will still be active when [Hand On] is activated:

- [Hand On] - [Off] - [Auto On]
- Reset
- Coasting stop inverse (motor coasting to stop)
- Reversing
- Set-up select lsb - Set-up select msb
- Stop command from serial communication
- Quick stop
- DC brake

NOTE

External stop signals activated by means of control signals or a serial bus will override a "start" command via the LCP.

[Off]

stops the connected motor (when pressed on the frequency converter LCP) or the filter (when pressed on the filter LCP). The key can be [1] Enabled or [0] Disabled via 0-41 [Off] Key on LCP. If no external stop function is selected and the [Off] key is inactive the motor can only be stopped by disconnecting the mains supply.

[Auto On]

enables the frequency converter to be controlled via the control terminals and/or serial communication. When a start signal is applied on the control terminals and/or the bus, the frequency converter will start. The key can be [1] Enabled or [0] Disabled via 0-42 [Auto on] Key on LCP.

NOTE

[Auto On] must be pressed on the filter LCP.

NOTE

An active HAND-OFF-AUTO signal via the digital inputs has higher priority than the control keys [Hand On] – [Auto On].

[Reset]

is used for resetting the frequency converter or filter after an alarm (trip). The key can be [1] Enabled or [0] Disabled via 0-43 [Reset] Key on LCP.

The parameter shortcut

can be carried out by holding down the [Main Menu] key for 3 seconds. The parameter shortcut allows direct access to any parameter.

5.1.3 Changing Data

1. Press [Quick Menu] or [Main Menu].
2. Use [▲] and [▼] to find parameter group to edit.
3. Press [OK].
4. Use [▲] and [▼] to find parameter to edit.
5. Press [OK].
6. Use [▲] and [▼] to select correct parameter setting. Or, to move to digits within a number, use [◀] and [▶]. Cursor indicates digit selected to change. [▲] key increases the value, [▼] key decreases the value.
7. Press [Cancel] to disregard change, or press [OK] to accept change and enter new setting.

5.1.4 Changing a Text Value

If the selected parameter is a text value, change the text value by means of the [▲]/[▼] keys.

[▲] increases the value, and [▼] decreases the value. Place the cursor on the value to be saved and press [OK].

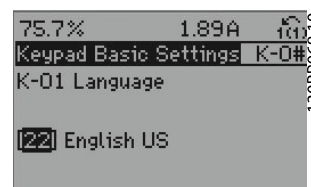

Illustration 5.13 Display Example.

Choose a parameter group from the Main Menu and Press [OK]. Then further select the parameter sub-groups by using [▲] and [▼] and then Press [OK].

The middle section of the keypad display shows the parameters. Press [OK] to select parameters and now the display shows that selected parameter's value.

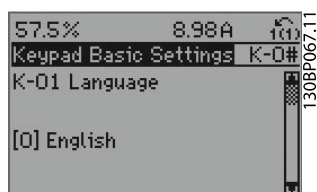

Illustration 5.14 Display Example.

5.1.5 Changing a Group of Numeric Data Values

If the chosen parameter represents a numeric data value, change the chosen data value by means of the [◀] and [▶] navigation keys as well as [▲] and [▼] keys. Use the [◀] and [▶] keys to move the cursor horizontally.



Illustration 5.15 Display Example

Use [▲]/[▼] to change the data value. [▲] enlarges the data value, and [▼] reduces the data value. Place the cursor on the value to be saved and press [OK].



Illustration 5.16 Display Example

5.1.6 Changing of Data Value, Step-by-Step

Certain parameters can be changed step by step or infinitely variably. This applies to 1-20 Motor Power [kW], 1-22 Motor Voltage and 1-23 Motor Frequency. The parameters are changed both as a group of numeric data values and as numeric data values infinitely variably.

5.1.7 Read-out and Programming of Indexed Parameters

Parameters are indexed when placed in a rolling stack. 15-30 Alarm Log: Error Code to 15-32 Alarm Log: Time contain a fault log which can be read out. Choose a parameter, press [OK], and use the up/down navigation keys to scroll through the value log.

Use 3-10 Preset Reference as another example: Choose the parameter, press [OK], and use [▲]/[▼] to scroll through the indexed values. To change the parameter value, select the indexed value and press [OK]. Change the value by using [▲]/[▼]. Press [OK] to accept the new setting. Press [Cancel] to abort. Press [Back] to leave the parameter.

5.1.8 Quick Transfer of Parameter Settings when using Keypad

Once the set-up of a frequency converter is complete, it is recommended to store (backup) the parameter settings in the or on a PC via DCT 10 software.

WARNING

Stop the motor before performing any of these operations.

Data storage in keypad

1. Go to 0-50 LCP Copy
2. Press the [OK] key
3. Select "All to keypad"
4. Press the [OK] key

All parameter settings are now stored in the keypad indicated by the progress bar. When 100% is reached, press [OK].

The keypad can now be connected to another frequency converter and the parameter settings copied to this frequency converter.

Data transfer from keypad to frequency converter

1. Go to 0-50 LCP Copy
2. Press the [OK] key
3. Select "All from keypad"
4. Press the [OK] key

The parameter settings stored in the graphical keypad are now transferred to the frequency converter indicated by the progress bar. When 100% is reached, press [OK].

5.1.9 Restore Factory Settings

There are two ways to restore the drive to factory settings: Recommended restore and manual restore. Be aware that they have different impact according to the below description.

Recommended restore (via 14-22 Operation Mode)

1. Select 14-22 Operation Mode
2. Press [OK]
3. Select [2] Restore Factory Settings
4. Press [OK]
5. Remove power to unit and wait for display to turn off.
6. Reconnect power and the frequency converter is reset.

NOTE

First start-up takes a few more seconds.

- 7. Press [Reset]

14-22 Operation Mode restores all except:

- 14-50 RFI Filter
- 8-30 Protocol
- 8-31 Address
- 8-32 Baud Rate
- 8-35 Minimum Response Delay
- 8-36 Max Response Delay
- 8-37 Maximum Inter-Char Delay
- 15-00 Operating Hours to 15-05 Over Volt's
- 15-20 Historic Log: Event to 15-22 Historic Log: Time
- 15-30 Alarm Log: Error Code to 15-32 Alarm Log: Time

Manual restore

NOTE

When carrying out manual restore, serial communication, RFI filter settings and fault log settings are reset.

1. Disconnect from mains and wait until the display turns off.
- 2a. Press [Status] - [Main Menu] - [OK] at the same time while power up for keypad
3. Release the keys after 5 sec.
4. The frequency converter is now programmed according to default settings

The Manual Restore restores all except:

- 15-00 Operating Hours
- 15-03 Power Up's
- 15-04 Over Temp's
- 15-05 Over Volt's

5.1.10 RS-485 Bus Connection

Both filter portion and frequency converter can be connected to a controller (or master) together with other loads using the RS-485 standard interface. Terminal 68 is connected to the P signal (TX+, RX+), while terminal 69 is connected to the N signal (TX-,RX-).

Always use parallel connections for the Low Harmonic Drive to ensure that both filter and drive part is connected.

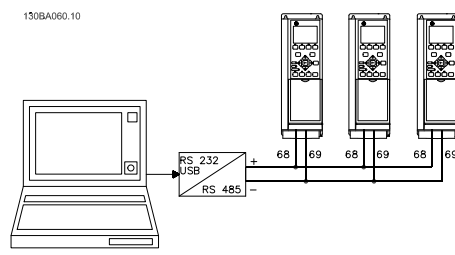

Illustration 5.17 Connection Example

To avoid potential equalizing currents in the screen, earth the cable screen via terminal 61, which is connected to the frame via an RC-link.

Bus termination

The RS-485 bus must be terminated by a resistor network at both ends. If the frequency converter is the first or the last device in the RS-485 loop, set the switch S801 on the control card for ON.

For more information, see the paragraph *Switches S201, S202, and S801.*

5.1.11 How to Connect a PC to the Frequency Converter

To control or program the frequency converter from a PC, install the PC-based Drive Control Tool DCT 10. The PC is connected via a standard (host/device) USB cable, or via the RS-485 interface as shown in the VLT® HVAC Drive *Design Guide, chapter How to Install > Installation of misc. connections.*

NOTE

The USB connection is galvanically isolated from the supply voltage (PELV) and other high-voltage terminals. The USB connection is connected to protection earth on the frequency converter. Use only an isolated laptop as PC connection to the USB connector on the frequency converter.

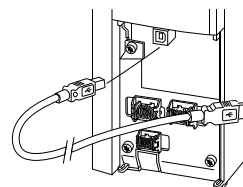

Illustration 5.18 For control cable connections, see 4.8.1 Electrical Installation, Control Cables.



5.1.12 PC Software Tools

PC-based

The Low Harmonic Drive is equipped with two serial communication ports. Danfoss provides a PC tool for communication between PC and frequency converter, PC-based Drive Control Tool DCT 10. Check 1.1.2 Available Literature for detailed information on this tool.

Drive Control Tool DCT 10

DCT 10 has been designed as an easy to use interactive tool for setting parameters in our frequency converters. .

The DCT 10 Drive Control Tool is useful for:

- Planning a communication network off-line. DCT 10 contains a complete frequency converter database
- Commissioning frequency converters on line
- Saving settings for all frequency converters
- Replacing a frequency converter in a network
- Simple and accurate documentation of frequency converter settings after commissioning.
- Expanding an existing network
- Future developed frequency converters will be supported

Drive Control Tool DCT 10 software supports Profibus DP-V1 via a Master class 2 connection. It makes it possible to on line read/write parameters in a frequency converter via the Profibus network. This will eliminate the need for an extra communication network.

Save frequency converter settings

1. Connect a PC to the unit via USB com port.



Use a PC, which is isolated from the mains, in conjunction with the USB port. Failure to do so may damage equipment.

2. Open Drives Control Tool DCT 10 Software
3. Choose "Read from drive"
4. Choose "Save as"

All parameters are now stored in the PC.

Load frequency converter settings

1. Connect a PC to the frequency converter via USB com port
2. Open Drives Control Tool DCT 10 software
3. Choose "Open"– stored files will be shown
4. Open the appropriate file

5. Choose "Write to drive"

All parameter settings are now transferred to the frequency converter.

A separate manual for Drives Control Tool DCT 10 Software is available from GE or the web: www.geelectrical.com/drives.

The Drives Control Tool DCT 10 software modules

The following modules are included in the software package:

<p>DCT 10 Software Setting parameters Copy to and from frequency converters Documentation and print out of parameter settings incl. diagrams</p>
<p>Ext. user interface Preventive Maintenance Schedule Clock settings Timed Action Programming Logic Controller Set-up</p>

Table 5.1

Ordering number

contact GE or visit: www.geelectrical.com/drives



6 How to Programme the Low Harmonic Drive

6.1 How to Programme the Frequency Converter

The parameters are grouped into various parameter groups for easy selection of the correct parameter for optimized frequency converter operation.

Overview of parameter groups

6

Group	Title	Function
0-**	Operation/Display	Parameters related to the fundamental functions of the frequency converter, function of the LCP keys and configuration of the LCP display.
1-**	Load/Motor	Parameter group for motor settings.
2-**	Brakes	Parameter group for setting brake features in the frequency converter.
3-**	Reference/Ramps	Parameters for reference handling, definitions of limitations, and configuration of the reaction of the frequency converter to changes.
4-**	Limits/Warnings	Parameter group for configuring limits and warnings.
5-**	Digital In/Out	Parameter group for configuring the digital inputs and outputs.
6-**	Analog In/Out	Parameter group for configuration of the analog inputs and outputs.
8-**	Communication and Options	Parameter group for configuring communications and options.
9-**	Profibus	Parameter group for Profibus-specific parameters (requires profibus option).
10-**	DeviceNet Fieldbus	Parameter group for DeviceNet-specific parameters (requires DeviceNet option).
13-**	Smart Logic	Parameter group for Smart Logic Control
14-**	Special Functions	Parameter group for configuring special frequency converter functions.
15-**	Drive Information	Parameter group containing frequency converter information such as operating data, hardware configuration and software versions.
16-**	Data Readouts	Parameter group for data read-outs, e.g. actual references, voltages, control, alarm, warning and status words.
18-**	Info and Readouts	This parameter group contains the last 10 Preventive Maintenance logs.
20-**	Drive Closed Loop	This parameter group is used for configuring the closed loop PID Controller that controls the output frequency of the unit.
21-**	Extended Closed Loop	Parameters for configuring the three Extended Closed Loop PID Controllers.
22-**	Application Functions	These parameters monitor water applications.
23-**	Time-based Functions	These parameters are for actions needed to be performed on a daily or weekly basis, e.g. different references for working hours/non-working hours.
24-**	Application Functions 2	Parameters for the Drive Bypass.
25-**	Basic Cascade Controller Functions	Parameters for configuring the Basic Cascade Controller for sequence control of multiple pumps.
26-**	Analog I/O Option MCB 109	Parameters for configuring the Analog I/O Option MCB 109.
27-**	Extended Cascade Control	Parameters for configuring the Extended Cascade Control (MCO 101/MCO 102).
29-**	Water Application Functions	Parameters for setting water specific functions.
30-**	Special Features	Parameters for configuring the brake resistor value.
31-**	Bypass Option	Parameters for configuring the Bypass Option (MCO 104).
35-**	Sensor Input Option	Parameters for configuring the Sensor Input Option (MCB 114)

Table 6.1 Parameter Groups

Parameter descriptions and selections are displayed on the graphic (GLCP) or numeric (NLCP) in the display area. (See *5 How to Operate the Low Harmonic Drive* for details.)

Access the parameters by pressing the [Quick Menu] or [Main Menu] key on the control panel. The quick menu is used primarily for commissioning the unit at start-up by

providing those parameters necessary to start operation. The main menu provides access to all parameters for detailed application programming.

All digital input/output and analog input/output terminals are multifunctional. All terminals have factory default functions suitable for the majority of water applications but if other special functions are required, they must be programmed in parameter group 5-** or 6-**.

6.1.1 Quick Menu Mode

The GLCP provides access to all parameters listed under the Quick Menus. To set parameters using the [Quick Menu] key:

Pressing [Quick Menu] the list indicates the different areas contained in the Quick menu.

Efficient parameter set-up for water applications

The parameters can easily be set up for the vast majority of the water and wastewater applications only by using the [Quick Menu].

The optimum way to set parameters through the [Quick Menu] is by following the below steps:

1. Press [Quick Setup] for selecting basic motor settings, ramp times, etc.
2. Press [Function Setups] for setting up the required functionality of the frequency converter - if not already covered by the settings in [Quick Setup].
3. Choose between *General Settings*, *Open Loop Settings* and *Closed Loop Settings*.

It is recommended to do the set-up in the order listed.

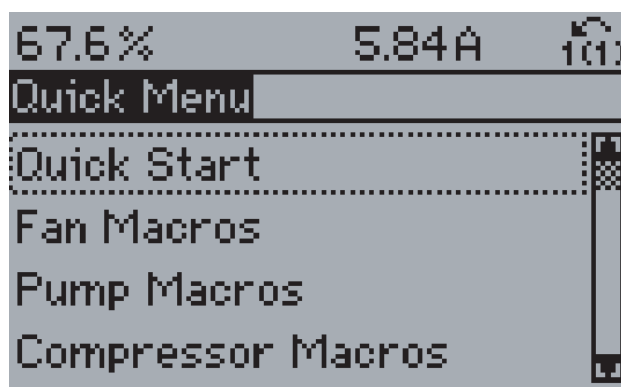

130BP064.10

Illustration 6.1 Quick Menu View

Par.	Designation	[Units]
0-01	Language	
1-20	Motor Power	[kW]
1-22	Motor Voltage	[V]
1-23	Motor Frequency	[Hz]
1-24	Motor Current	[A]
1-25	Motor Nominal Speed	[RPM]
3-41	Ramp 1 Ramp up Time	[s]
3-42	Ramp 1 Ramp down Time	[s]
4-11	Motor Speed Low Limit	[RPM]
4-13	Motor Speed High Limit	[RPM]
1-29	Automatic Motor Adaptation (AMA)	

Table 6.2 Quick Setup parameters.

See 6.3 Description of Common Parameters

If *No Operation* is selected in terminal 27 no connection to +24 V on terminal 27 is necessary to enable start. If *Coast Inverse* (factory default value) is selected in Terminal 27, a connection to +24 V is necessary to enable start.

For detailed parameter descriptions, see 6.3 Description of Common Parameters.

6.1.2 Q1 My Personal Menu

Parameters defined by the user can be stored in Q1 My Personal Menu.

Select *My Personal Menu* to display only the parameters, which have been pre-selected and programmed as personal parameters. For example, a pump or equipment OEM may have pre-programmed these to be in My Personal Menu during factory commissioning to make on site commissioning/fine tuning simpler. These parameters are selected in par. 0-25 *My Personal Menu*. Up to 20 different parameters can be defined in this menu.

Q1 My Personal Menu
20-21 Setpoint 1
20-93 PID Proportional Gain
20-94 PID Integral Time

Table 6.3

6.1.3 Q2 Quick Setup

The parameters in Q2 Quick Setup are the basic parameters which are always needed to set-up the frequency converter to operation.

Q2 Quick Setup	
Parameter number and name	Unit
0-01 Language	
1-20 Motor Power	kW
1-22 Motor Voltage	V
1-23 Motor Frequency	Hz
1-24 Motor Current	A
1-25 Motor Nominal Speed	RPM
3-41 Ramp 1 Ramp Up Time	s
3-42 Ramp 1 Ramp Down Time	s
4-11 Motor Speed Low Limit	RPM
4-13 Motor Speed High Limit	RPM
1-29 Automatic Motor Adaptation (AMA)	

Table 6.4

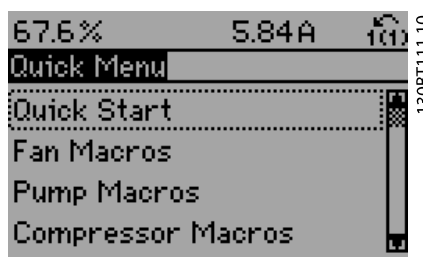

Illustration 6.3

6

6.1.4 Q3 Function Setups

The Function Setup provides quick and easy access to all parameters required for the majority of water and wastewater applications including variable torque, constant torque, pumps, dosing pumps, well pumps, booster pumps, mixer pumps, aeration blowers and other pump and fan applications. Amongst other features it also includes parameters for selecting which variables to display on the LCP, digital preset speeds, scaling of analog references, closed loop single zone and multi-zone applications and specific functions related to water and wastewater applications.

How to access Function Set-up - example:

1. Turn on the frequency converter (On LED lights)



Illustration 6.2

2. Press the [Quick Menus] key (Quick Menu choices appear).

- Use [▲]/[▼] navigation keys to scroll down to Function Setups. Press [OK].

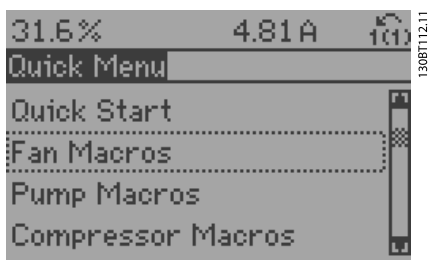

Illustration 6.4

- Function Setups choices appear. Choose Q3-1 General Settings. Press [OK].

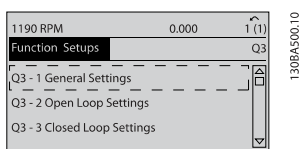

Illustration 6.5

- Use [▲]/[▼] keys to scroll down to i.e. Q3-12 Analog Outputs. Press [OK].

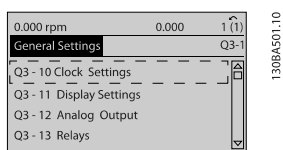

Illustration 6.6

- Choose 6-50 Terminal 42 Output. Press [OK].

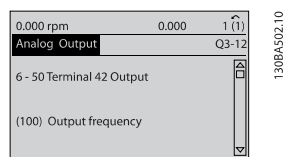

Illustration 6.7

- Use [▲]/[▼] keys to select between the different choices. Press [OK].

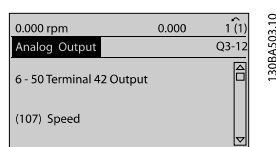

Illustration 6.8



The Function Setup parameters are grouped in the following way:

Q3-1 General Settings			
Q3-10 Clock Settings	Q3-11 Display Settings	Q3-12 Analog Output	Q3-13 Relays
0-70 Set Date and Time	0-20 Display Line 1.1 Small	6-50 Terminal 42 Output	Relay 1 ⇒ 5-40 Function Relay
0-71 Date Format	0-21 Display Line 1.2 Small	6-51 Terminal 42 Output Min Scale	Relay 2 ⇒ 5-40 Function Relay
0-72 Time Format	0-22 Display Line 1.3 Small	6-52 Terminal 42 Output Max Scale	Option relay 7 ⇒ 5-40 Function Relay
0-74 DST/Summertime	0-23 Display Line 2 Large		Option relay 8 ⇒ 5-40 Function Relay
0-76 DST/Summertime Start	0-24 Display Line 3 Large		Option relay 9 ⇒ 5-40 Function Relay
0-77 DST/Summertime End	0-37 Display Text 1		
	0-38 Display Text 2		
	0-39 Display Text 3		

Table 6.5

Q3-2 Open Loop Settings	
Q3-20 Digital Reference	Q3-21 Analog Reference
3-02 Minimum Reference	3-02 Minimum Reference
3-03 Maximum Reference	3-03 Maximum Reference
3-10 Preset Reference	6-10 Terminal 53 Low Voltage
5-13 Terminal 29 Digital Input	6-11 Terminal 53 High Voltage
5-14 Terminal 32 Digital Input	6-14 Terminal 53 Low Ref/Feedb. Value
5-15 Terminal 33 Digital Input	6-15 Terminal 53 High Ref/Feedb. Value

Table 6.6

Q3-3 Closed Loop Settings	
Q3-30 Feedback Settings	Q3-31 PID Settings
1-00 Configuration Mode	20-81 PID Normal/Inverse Control
20-12 Reference/Feedb.Unit	20-82 PID Start Speed [RPM]
3-02 Minimum Reference	20-21 Setpoint 1
3-03 Maximum Reference	20-93 PID Proportional Gain
6-20 Terminal 54 Low Voltage	20-94 PID Integral Time
6-21 Terminal 54 High Voltage	
6-24 Terminal 54 Low Ref/Feedb Value	
6-25 Terminal 54 High Ref/Feedb Value	
6-00 Live Zero Timeout Time	
6-01 Live Zero Timeout Function	

Table 6.7



6.1.5 Q5 Changes Made

Q5 Changes Made can be used for fault finding.

Select **Changes made to get information about:**

- the last 10 changes. Use the up/down navigation keys to scroll between the last 10 changed parameters.
- the changes made since default setting.

Select *Loggings* to get information about the display line read-outs. The information is shown as graphs.

Only display parameters selected in *0-20 Display Line 1.1 Small* and *0-24 Display Line 3 Large* can be viewed. It is possible to store up to 120 samples in the memory for later reference.

Note that the parameters listed in the below tables for Q5 only serve as examples as they will vary depending on the programming of the particular frequency converter.

Q5-1 Last 10 Changes
20-94 PID Integral Time
20-93 PID Proportional Gain

Table 6.8

Q5-2 Since Factory Setting
20-93 PID Proportional Gain
20-94 PID Integral Time

Table 6.9

Q5-3 Input Assignments
Analog Input 53
Analog Input 54

Table 6.10

6.1.6 Q6 Loggings

Q6 Loggings can be used for fault finding.

Notice that the parameters listed in the below table for Q6 only serve as examples as they will vary depending on the programming of the particular frequency converter.

Q6 Loggings
Reference
Analog Input 53
Motor Current
Frequency
Feedback
Energy Log
Trending Cont Bin
Trending Timed Bin
Trending Comparison

Table 6.11

6.1.7 Main Menu Mode

The keypad provides access to the main menu mode. Select the Main Menu mode by pressing the [Main Menu] key. Illustration 6.2 shows the resulting read-out, which appears on the display of the keypad. Lines 2 through 5 on the display show a list of parameter groups which can be chosen by toggling [▲] and [▼].



Illustration 6.9 Display Example

Each parameter has character(s) and number which remain the same regardless of the programming mode. In the Main Menu mode, the parameters are further divided into groups: Macros, Keypad Set-Up, Parameter Data Set, Parameter Data Check, Drive Information, Data Readouts, Logs & I/O Option Status, and Advanced Parameter Data Set.

All parameters can be changed in the Main Menu. The configuration of the unit (*1-00 Configuration Mode*) will determine other parameters available for programming. For example, selecting [3] *Closed Loop* enables additional parameters related to closed loop operation. Option cards added to the unit enable additional parameters associated with the option device.

6.1.8 Parameter Selection



The following parameter groups are accessible:

Main Menu Item	Parameter Groups:
Keypad Set-Up	K-##
Parameter Data Set	F-##, E-##, C-##, P-##, H-##, AN-##, SP-##, O-##, AO-##, DN-##, PB-##, LN-##, BN-##
Drive Information	ID-##
Data Readouts	DR-##
Logs & I/O Option Status	LG-##
Advanced Parameter Data Set	AP-##, FB-##, T-##, CL-##, XC-##, PC-##, LC-##, B-##

Table 6.12 Parameter Groups in Main Menu Items

Group no.	Parameter group:
K-##	Keypad Set-Up
F-##	Fundamental Parameters
E-##	Digital In/Out
C-##	Frequency Control Functions
P-##	Motor Data
H-##	High Perf Parameters
AN-##	Analog In/Out
SP-##	Special Functions
O-##	Options / Comms
AO-##	Analog I/O Option
DN-##	DeviceNet
PB-##	Profibus
LN-##	LonWorks
BN-##	BACnet
ID-##	Drive Information
DR-##	Data Readouts
LG-##	Logs & I/O Opt. Status
AP-##	HVAC Appl. Param.
FB-##	Fire/Bypass Operation
EN-##	EtherNet
T-##	Timed Functions
CL-##	PID Closed Loop
XC-##	Ext. PID Closed Loop
PC-##	Pump Controller
LC-##	Logic Controller
B-##	Braking Functions

Table 6.13 Parameter groups.

Overview of parameter groups for the filter part

Group	Title	Function
0-	Operation / Display	Parameters related to the fundamental functions of the filter, function of the LCP buttons and configuration of the LCP display.
5-	Digital In/Out	Parameter group for configuring the digital inputs and outputs.
8-	Communication and Options	Parameter group for configuring communications and options.
14-	Special Functions	Parameter group for configuring special functions.
15-	Unit Information	Parameter group containing active filter information such as operating data, hardware configuration and software versions.
16-	Data Readouts	Parameter group for data read-outs, e.g. actual references, voltages, control, alarm, warning and status words.
300-	AF Settings	Parameter group for setting the Active Filter. Apart from <i>300-10 Active Filter Nominal Voltage</i> , it is not recommended to change the settings of this parameter group
301-	AF Readouts	Parameter group for the filter readouts.

Table 6.14 Parameter groups

A list of all parameters accessible from the filter LCP can be found in the section *Parameter Options - Filter*. A more

Choose a parameter group from the Main Menu and Press [OK]. Then further select the parameter sub-groups by using the up and down arrows and then Press [OK]. The middle section of the keypad display shows the parameters. Press [OK] to select parameters and now the display shows that selected parameter's value.

6.2 How to Programme the Active Filter

The factory settings for the filter part of the Low Harmonic Drive are chosen for optimal operation with a minimum of additional programming. All CT-values, as well as frequency, voltage levels and other values directly linked to the drive configuration are pre-set.

It is not recommended to change any other parameters influencing the filter operation. However, selection of read-outs and what information to be displayed on the LCP status lines can be made to fit individual preferences.

To set up the filter two steps are necessary:

- Change the nominal voltage in *300-10 Active Filter Nominal Voltage*
- Make sure the filter is in auto mode (press [Auto On])

detailed description of the active filter parameters can be found in the VLT Active Filter AAF005 Manual, *MG90VXY*



6.2.1 Using the Low Harmonic Drive in NPN Mode

The default setting for *5-00 Digital I/O Mode* is PNP mode. If NPN mode is desired, it is necessary to change the wiring in the filter part of the Low Harmonic Drive. Before changing the setting in *5-00 Digital I/O Mode* to NPN mode, the wire connected to 24 V (control terminal 12 or 13) must be changed to terminal 20 (ground).



6.3 Description of Common Parameters

6.3.1 Main Menu

The Main Menu includes all available parameters in the frequency converter.

All parameters are grouped in a logic way with a group name indicating the function of the parameter group.

All parameters are listed by name and number in

6.4 *Parameter Options*.

All parameters included in the Quick Menus (Q1, Q2, Q3, Q5 and Q6) can be found in the following.

Some of the most used parameters for VLT® Automation VT Drive FC 322 applications are also explained in the following section.

For a detailed explanation of all parameters, refer to the VLT® Automation VT Drive FC 322 Programming Guide MG200 which is available <http://www.danfoss.com/BusinessAreas/DrivesSolutions/Documentations/Technical+Documentation.htm> or by ordering at the local Danfoss office.

Parameters related to the fundamental functions of the frequency converter, function of the LCP keys and configuration of the LCP display.

0-01 Language

Option:	Function:
	Defines the language to be used in the display. The frequency converter can be delivered with 4 different language packages. English and German are included in all packages. English cannot be erased or manipulated.
[0] * English	Part of Language packages 1 - 4
[1] German	Part of Language packages 1 - 4
[2] French	Part of Language package 1
[3] Danish	Part of Language package 1
[4] Spanish	Part of Language package 1
[5] Italian	Part of Language package 1
[6] Swedish	Part of Language package 1
[7] Dutch	Part of Language package 1
[10] Chinese	Language package 2
[20] Finnish	Part of Language package 1
[22] English US	Part of Language package 4
[27] Greek	Part of Language package 4
[28] Portuguese	Part of Language package 4
[36] Slovenian	Part of Language package 3
[39] Korean	Part of Language package 2
[40] Japanese	Part of Language package 2
[41] Turkish	Part of Language package 4

0-01 Language

Option:	Function:
[42] Traditional Chinese	Part of Language package 2
[43] Bulgarian	Part of Language package 3
[44] Serbian	Part of Language package 3
[45] Romanian	Part of Language package 3
[46] Hungarian	Part of Language package 3
[47] Czech	Part of Language package 3
[48] Polish	Part of Language package 4
[49] Russian	Part of Language package 3
[50] Thai	Part of Language package 2
[51] Bahasa Indonesian	Part of Language package 2

0-20 Display Line 1.1 Small

Option:	Function:
	Select a variable for display in line 1, left position.
[0] None	No display value selected
[37] Display Text 1	Present control word
[38] Display Text 2	Enables an individual text string to be written, for display in the LCP or to be read via serial communication.
[39] Display Text 3	Enables an individual text string to be written, for display in the LCP or to be read via serial communication.
[89] Date and Time Readout	Displays the current date and time.
[953] Profibus Warning Word	Displays Profibus communication warnings.
[1005] Readout Transmit Error Counter	View the number of CAN control transmission errors since the last power-up.
[1006] Readout Receive Error Counter	View the number of CAN control receipt errors since the last power-up.
[1007] Readout Bus Off Counter	View the number of Bus Off events since the last power-up.
[1013] Warning Parameter	View a DeviceNet-specific warning word. One separate bit is assigned to every warning.
[1230] Warning Parameter	
[1500] Operating Hours	View the number of running hours of the frequency converter.
[1501] Running Hours	View the number of running hours of the motor.
[1502] kWh Counter	View the mains power consumption in kWh.



0-20 Display Line 1.1 Small		
Option:	Function:	
[1600]	Control Word	View the Control Word sent from the frequency converter via the serial communication port in hex code.
[1601] *	Reference [Unit]	Total reference (sum of digital/analog/preset/bus/freeze ref./catch up and slow-down) in selected unit.
[1602]	Reference [%]	Total reference (sum of digital/analog/preset/bus/freeze ref./catch up and slow-down) in percent.
[1603]	Status Word	Present status word
[1605]	Main Actual Value [%]	One or more warnings in a Hex code
[1609]	Custom Readout	View the user-defined readouts as defined in <i>0-30 Custom Readout Unit</i> , <i>0-31 Custom Readout Min Value</i> and <i>0-32 Custom Readout Max Value</i> .
[1610]	Power [kW]	Actual power consumed by the motor in kW.
[1611]	Power [hp]	Actual power consumed by the motor in HP.
[1612]	Motor Voltage	Voltage supplied to the motor.
[1613]	Frequency	Motor frequency, i.e. the output frequency from the frequency converter in Hz.
[1614]	Motor Current	Phase current of the motor measured as effective value.
[1615]	Frequency [%]	Motor frequency, i.e. the output frequency from the frequency converter in percent.
[1616]	Torque [Nm]	Present motor load as a percentage of the rated motor torque.
[1617] *	Speed [RPM]	Speed in RPM (revolutions per minute) i.e. the motor shaft speed in closed loop based on the entered motor nameplate data, the output frequency and the load on the frequency converter.
[1618]	Motor Thermal	Thermal load on the motor, calculated by the ETR function. See also parameter group 1-9* <i>Motor Temperature</i> .
[1622]	Torque [%]	Shows the actual torque produced, in percentage.
[1630]	DC Link Voltage	Intermediate circuit voltage in the frequency converter.
[1632]	Brake Energy /s	Present brake power transferred to an external brake resistor.

0-20 Display Line 1.1 Small		
Option:	Function:	
		Stated as an instantaneous value.
[1633]	Brake Energy /2 min	Brake power transferred to an external brake resistor. The mean power is calculated continuously for the most recent 120 seconds.
[1634]	Heatsink Temp.	Present heat sink temperature of the frequency converter. The cut-out limit is 95 ±5 °C; cutting back in occurs at 70 ±5° C.
[1635]	Inverter Thermal	Percentage load of the inverters
[1636]	Inv. Nom. Current	Nominal current of the frequency converter
[1637]	Inv. Max. Current	Maximum current of the frequency converter
[1638]	SL Controller State	State of the event executed by the control
[1639]	Control Card Temp.	Temperature of the control card.
[1650]	External Reference	Sum of the external reference as a percentage, i.e. the sum of analog/pulse/bus.
[1652]	Feedback [Unit]	Signal value in units from the programmed digital input(s).
[1653]	Digi Pot Reference	View the contribution of the digital potentiometer to the actual reference Feedback.
[1654]	Feedback 1 [Unit]	View the value of Feedback 1. See also parameter group 20-0*.
[1655]	Feedback 2 [Unit]	View the value of Feedback 2. See also parameter group 20-0*.
[1656]	Feedback 3 [Unit]	View the value of Feedback 3. See also parameter group 20-0*.
[1658]	PID Output [%]	Returns the Drive Closed Loop PID controller output value in percent.
[1659]	Adjusted Setpoint	Displays the actual operating setpoint after it is modified by flow compensation. See parameter group 22-8*.
[1660]	Digital Input	Displays the status of the digital inputs. Signal low = 0; Signal high = 1. Regarding order, see <i>16-60 Digital Input</i> . Bit 0 is at the extreme right.
[1661]	Terminal 53 Switch Setting	Setting of input terminal 53. Current = 0; Voltage = 1.
[1662]	Analog Input 53	Actual value at input 53 either as a reference or protection value.



0-20 Display Line 1.1 Small		
Option:	Function:	
[1663]	Terminal 54 Switch Setting	Setting of input terminal 54. Current = 0; Voltage = 1.
[1664]	Analog Input 54	Actual value at input 54 either as reference or protection value.
[1665]	Analog Output 42 [mA]	Actual value at output 42 in mA. Use <i>6-50 Terminal 42 Output</i> to select the variable to be represented by output 42.
[1666]	Digital Output [bin]	Binary value of all digital outputs.
[1667]	Pulse Input #29 [Hz]	Actual value of the frequency applied at terminal 29 as a pulse input.
[1668]	Pulse Input #33 [Hz]	Actual value of the frequency applied at terminal 33 as a pulse input.
[1669]	Pulse Output #27 [Hz]	Actual value of pulses applied to terminal 27 in digital output mode.
[1670]	Pulse Output #29 [Hz]	Actual value of pulses applied to terminal 29 in digital output mode.
[1671]	Relay Output [bin]	View the setting of all relays.
[1672]	Counter A	View the present value of Counter A.
[1673]	Counter B	View the present value of Counter B.
[1675]	Analog In X30/11	Actual value of the signal on input X30/11 (General Purpose I/O Card. Option)
[1676]	Analog In X30/12	Actual value of the signal on input X30/12 (General Purpose I/O Card. Optional)
[1677]	Analog Out X30/8 [mA]	Actual value at output X30/8 (General Purpose I/O Card. Optional) Use <i>6-60 Terminal X30/8 Output</i> to select the variable to be shown.
[1680]	Fieldbus CTW 1	Control word (CTW) received from the Bus Master.
[1682]	Fieldbus REF 1	Main reference value sent with control word via the serial communications network e.g. from the BMS, PLC or other master controller.
[1684]	Comm. Option STW	Extended fieldbus communication option status word.
[1685]	FC Port CTW 1	Control word (CTW) received from the Bus Master.
[1686]	FC Port REF 1	Status word (STW) sent to the Bus Master.

0-20 Display Line 1.1 Small		
Option:	Function:	
[1690]	Alarm Word	One or more alarms in a Hex code (used for serial communications)
[1691]	Alarm Word 2	One or more alarms in a Hex code (used for serial communications)
[1692]	Warning Word	One or more warnings in a Hex code (used for serial communications)
[1693]	Warning Word 2	One or more warnings in a Hex code (used for serial communications)
[1694]	Ext. Status Word	One or more status conditions in a Hex code (used for serial communications)
[1695]	Ext. Status Word 2	One or more status conditions in a Hex code (used for serial communications)
[1696]	Maintenance Word	The bits reflect the status for the programmed Preventive Maintenance Events in parameter group 23-1*
[1830]	Analog Input X42/1	Shows the value of the signal applied to terminal X42/1 on the Analog I/O card.
[1831]	Analog Input X42/3	Shows the value of the signal applied to terminal X42/3 on the Analog I/O card.
[1832]	Analog Input X42/5	Shows the value of the signal applied to terminal X42/5 on the Analog I/O card.
[1833]	Analog Out X42/7 [V]	Shows the value of the signal applied to terminal X42/7 on the Analog I/O card.
[1834]	Analog Out X42/9 [V]	Shows the value of the signal applied to terminal X42/9 on the Analog I/O card.
[1835]	Analog Out X42/11 [V]	Shows the value of the signal applied to terminal X42/11 on the Analog I/O card.
[1836]	Analog Input X48/2 [mA]	
[1837]	Temp. Input X48/4	
[1838]	Temp. Input X48/7	
[1839]	Temp. Input X48/10	
[1860]	Digital Input 2	
[2117]	Ext. 1 Reference [Unit]	The value of the reference for extended Closed Loop Controller 1
[2118]	Ext. 1 Feedback [Unit]	The value of the feedback signal for extended Closed Loop Controller 1



0-20 Display Line 1.1 Small		
Option:	Function:	
[2119]	Ext. 1 Output [%]	The value of the output from extended Closed Loop Controller 1
[2137]	Ext. 2 Reference [Unit]	The value of the reference for extended Closed Loop Controller 2
[2138]	Ext. 2 Feedback [Unit]	The value of the feedback signal for extended Closed Loop Controller 2
[2139]	Ext. 2 Output [%]	The value of the output from extended Closed Loop Controller 2
[2157]	Ext. 3 Reference [Unit]	The value of the reference for extended Closed Loop Controller 3
[2158]	Ext. 3 Feedback [Unit]	The value of the feedback signal for extended Closed Loop Controller 3
[2159]	Ext. 3 Output [%]	The value of the output from extended Closed Loop Controller 3
[2230]	No-Flow Power	The calculated No Flow Power for the actual operating speed
[2316]	Maintenance Text	
[2580]	Cascade Status	Status for the operation of the Cascade Controller
[2581]	Pump Status	Status for the operation of each individual pump controlled by the Cascade Controller
[2791]	Cascade Reference	Reference output for use with follower drives.
[2792]	% Of Total Capacity	Readout parameter to show the system operating point as a % capacity of total system capacity.
[2793]	Cascade Option Status	Readout parameter to show the status of the cascade system.
[2794]	Cascade System Status	
[2795]	Advanced Cascade Relay Output [bin]	
[2796]	Extended Cascade Relay Output [bin]	
[2920]	Derag Power[kW]	
[2921]	Derag Power[HP]	
[3110]	Bypass Status Word	
[3111]	Bypass Running Hours	
[9920]	HS Temp. (PC1)	
[9921]	HS Temp. (PC2)	
[9922]	HS Temp. (PC3)	
[9923]	HS Temp. (PC4)	
[9924]	HS Temp. (PC5)	
[9925]	HS Temp. (PC6)	
[9926]	HS Temp. (PC7)	

0-20 Display Line 1.1 Small		
Option:	Function:	
[9927]	HS Temp. (PC8)	

0-21 Display Line 1.2 Small		
Option:	Function:	
		Select a variable for display in line 1, middle position.
[1662] *	Analog input 53	The options are the same as those listed for 0-20 Display Line 1.1 Small.

0-22 Display Line 1.3 Small		
Option:	Function:	
		Select a variable for display in line 1, right position.
[1614] *	Motor Current	The options are the same as those listed for 0-20 Display Line 1.1 Small.

0-23 Display Line 2 Large		
Option:	Function:	
		Select a variable for display in line 2.
[1615] *	Frequency	The options are the same as those listed for par. 0-20 Display Line 1.1 Small

0-24 Display Line 3 Large		
Option:	Function:	
[1652] *	Feedback [Unit]	The options are the same as those listed for 0-20 Display Line 1.1 Small.
		Select a variable for display in line 2.

0-37 Display Text 1		
Range:	Function:	
0 * [0 - 0]	In this parameter it is possible to write an individual text string for display in the LCP or to be read via serial communication. If to be displayed permanently select Display Text 1 in 0-20 Display Line 1.1 Small, 0-21 Display Line 1.2 Small, 0-22 Display Line 1.3 Small, 0-23 Display Line 2 Large or 0-24 Display Line 3 Large. Use the [▲] or [▼] buttons on the LCP to change a character. Use the [◀] and [▶] buttons to move the cursor. When a character is highlighted by the cursor, it can be changed. Use the [▲] or [▼] on the LCP to change a character. A character can be inserted by placing the cursor between two characters and pressing [▲] or [▼].	



0-38 Display Text 2		
Range:	Function:	
0 * [0 - 0]	In this parameter it is possible to write an individual text string for display in the LCP or to be read via serial communication. If to be displayed permanently select Display Text 2 in 0-20 Display Line 1.1 Small, 0-21 Display Line 1.2 Small, 0-22 Display Line 1.3 Small, 0-23 Display Line 2 Large or 0-24 Display Line 3 Large. Use [▲] or [▼] on the LCP to change a character. Use [◀] and [▶] to move the cursor. When a character is highlighted by the cursor, this character can be changed. A character can be inserted by placing the cursor between two characters and pressing [▲] or [▼].	

0-39 Display Text 3		
Range:	Function:	
0 * [0 - 0]	In this parameter it is possible to write an individual text string for display in the LCP or to be read via serial communication. If to be displayed permanently select Display Text 3 in 0-20 Display Line 1.1 Small, 0-21 Display Line 1.2 Small, 0-22 Display Line 1.3 Small, 0-23 Display Line 2 Large or 0-24 Display Line 3 Large. Use [▲] or [▼] on the LCP to change a character. Use [◀] and [▶] to move the cursor. When a character is highlighted by the cursor, this character can be changed. A character can be inserted by placing the cursor between two characters and pressing [▲] or [▼].	

0-70 Date and Time		
Range:	Function:	
Size related*	[0 - 0]	

0-71 Date Format		
Option:	Function:	
[0] * YYYY-MM-DD	Sets the date format to be used in the LCP.	
[1] DD-MM-YYYY	Sets the date format to be used in the LCP.	
[2] MM/DD/YYYY	Sets the date format to be used in the LCP.	

0-72 Time Format		
Option:	Function:	
	Sets the time format to be used in the LCP.	
[0]	24 h	
[1] *	12 h	

0-74 DST/Summertime		
Option:	Function:	
	Choose how Daylight Saving Time/Summertime should be handled. For manual DST/Summertime enter the start date and end date in 0-76 DST/Summertime Start and 0-77 DST/Summertime End.	
[0] *	Off	

0-74 DST/Summertime		
Option:	Function:	
[2]	Manual	

0-76 DST/Summertime Start		
Range:	Function:	
Size related*	[0 - 0]	

0-77 DST/Summertime End		
Range:	Function:	
Size related*	[0 - 0]	

6.3.2 General Settings

Define whether the frequency converter operates in open loop or closed loop.

1-00 Configuration Mode		
Option:	Function:	
[0] * Open Loop	Motor speed is determined by applying a speed reference or by setting desired speed when in Hand Mode. Open Loop is also used if the frequency converter is part of a closed loop control system based on an external PID controller providing a speed reference signal as output.	
[3] Closed Loop	Motor Speed will be determined by a reference from the built-in PID controller varying the motor speed as part of a closed loop control process (e.g. constant pressure or flow). The PID controller must be configured in parameter group CL-## or via the Function Setups accessed by pressing the [Quick Menus] button.	

NOTE

This parameter cannot be changed while the motor is running.

NOTE

When set for Closed Loop, the commands Reversing and Start Reversing will not reverse the direction of the motor.

NOTE

1-20 Motor Power [kW], 1-21 Motor Power [HP], 1-22 Motor Voltage and 1-23 Motor Frequency will not have effect when 1-10 Motor Construction = [1] PM, non salient SPM.



1-20 Motor Power [kW]		
Range:		Function:
Size related*	[0.09 - 2000.00 kW]	Enter the nominal motor power in kW according to the motor nameplate data. The default value corresponds to the nominal rated output of the unit. This parameter cannot be adjusted while the motor is running. Depending on the choices made in 0-03 Regional Settings, either 1-20 Motor Power [kW] or 1-21 Motor Power [HP] is made invisible.

1-22 Motor Voltage		
Range:		Function:
Size related*	[10. - 1000. V]	Enter the nominal motor voltage according to the motor nameplate data. The default value corresponds to the nominal rated output of the unit. This parameter cannot be adjusted while the motor is running.

1-23 Motor Frequency		
Range:		Function:
Size related*	[20 - 1000 Hz]	Select the motor frequency value from the motor nameplate data.

NOTE

This parameter cannot be changed while the motor is running.

1-24 Motor Current		
Range:		Function:
Size related*	[0.10 - 10000.00 A]	Enter the nominal motor current value from the motor nameplate data. This data is used for calculating motor torque, motor thermal protection etc.

NOTE

This parameter cannot be changed while the motor is running.

1-25 Motor Nominal Speed		
Range:		Function:
Size related*	[100 - 60000 RPM]	Enter the nominal motor speed value from the motor nameplate data. This data is used for calculating automatic motor compensations.

NOTE

This parameter cannot be changed while the motor is running.

1-29 Automatic Motor Adaptation (AMA)		
Option:		Function:
		The Auto Tune function optimizes dynamic motor performance by automatically optimizing the advanced motor 1-30 Stator Resistance (Rs) to 1-35 Main Reactance (Xh) while the motor is stationary.
[0] *	Off	No function
[1]	Enable complete AMA	Performs Auto Tune of the stator resistance Rs, the rotor resistance Rr, the stator leakage reactance X1, the rotor leakage reactance X2 and the main reactance Xh.
[2]	Enable reduced AMA	Performs a reduced Auto Tune of the stator resistance Rs in the system only. Select this option if an LC filter is used between the frequency converter and the motor.

NOTE

1-29 Automatic Motor Adaptation (AMA) will not have effect when 1-10 Motor Construction = [1] PM, non salient SPM.

Activate the Auto Tune function by pressing [Hand] after selecting [1] Enable complete AMA or [2] Enable reduced AMA. After a normal sequence, the display will read: "Press [OK] to finish Auto Tune". After pressing the [OK] key the frequency converter is ready for operation.

NOTE

- For the best results of the frequency converter, run Auto Tune on a cold motor
- Auto Tune cannot be performed while the motor is running

NOTE

Avoid generating external torque during Auto Tune.

NOTE

If one of the settings in parameter group P-## Motor Data is changed, 1-30 Stator Resistance (Rs) to 1-39 Motor Poles, the advanced motor parameters, will return to default setting.

This parameter cannot be adjusted while the motor is running.

NOTE

Full Auto Tune should be run without filter only while reduced Auto Tune should be run with filter.



6

3-04 Reference Function		
Option:	Function:	
[0] *	Sum	Sums both external and preset reference sources.
[1]	External/Preset	Use either the preset or the external reference source. Shift between external and preset via a command on a digital input.

3-10 Preset Reference		
Array [8]		
Range:	Function:	
0.00 %* [-100.00 - 100.00 %]	Enter up to eight different preset references (0-7) in this parameter, using array programming. The preset reference is stated as a percentage of the value Ref _{MAX} (3-03 Maximum Reference, for closed loop see CL-14 Maximum Reference/Feedb.). When using preset references, select Preset ref. bit 0/1/2 [16], [17] or [18] for the corresponding digital inputs in parameter group E-0# Digital Inputs.	

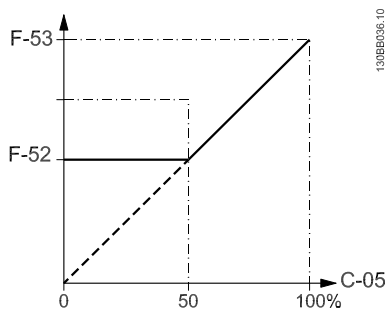

Illustration 6.10

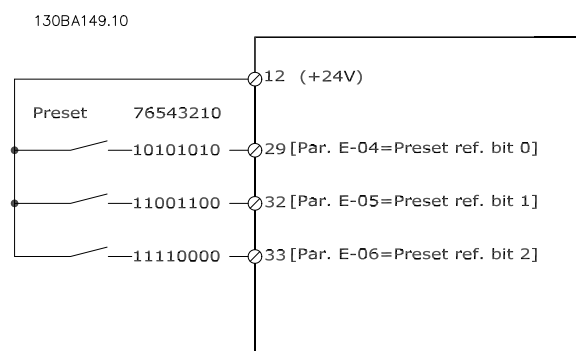

Illustration 6.11

3-41 Ramp 1 Ramp Up Time		
Range:	Function:	
Size related* [0.10 - 3600.00 s]	Enter the accel time, i.e. the acceleration time from 0 RPM to 1-25 Motor Nominal Speed. Choose a	

3-41 Ramp 1 Ramp Up Time		
Range:	Function:	
	accel time such that the output current does not exceed the current limit in 4-18 Current Limit during ramping. See decel time in 3-42 Ramp 1 Ramp Down Time.	

$$par. F - 07 = \frac{tacc \times nnorm [par.P - 06]}{ref [rpm]} [s]$$

3-42 Ramp 1 Ramp Down Time		
Range:	Function:	
Size related* [0.10 - 3600.00 s]	Enter the decel time, i.e. the deceleration time from 1-25 Motor Nominal Speed to 0 RPM. Choose a decel time such that no over-voltage arises in the inverter due to regenerative operation of the motor, and such that the generated current does not exceed the current limit set in 4-18 Current Limit. See accel time in 3-41 Ramp 1 Ramp Up Time.	

$$par. F - 08 = \frac{tdec \times nnorm [par.P - 06]}{ref [rpm]} [s]$$

3-84 Initial Ramp Time		
Range:	Function:	
0.00 s* [0.00 - 60.00 s]	Enter the initial ramp up time from zero speed to Motor Speed Low Limit, 4-11 Motor Speed Low Limit [RPM] or 4-12 Motor Speed Low Limit [Hz]. Submersible deep well pumps can be damaged by running below minimum pump speed. A fast ramp time below minimum pump speed is recommended. This parameter may be applied as a fast ramp rate from zero speed to Motor Speed Low Limit.	

3-85 Check Valve Ramp Time		
Range:	Function:	
0.00 s* [0.00 - 60.00 s]	In order to protect ball check valves in a stop situation, the check valve ramp can be utilized as a slow ramp rate from 4-11 Motor Speed Low Limit [RPM] or 4-12 Motor Speed Low Limit [Hz], to Check Valve Ramp End Speed, set by the user in 3-86 Check Valve Ramp End Speed [RPM] or 3-87 Check Valve Ramp End Speed [HZ]. When 3-85 Check Valve Ramp Time is different from 0 seconds, the Check Valve Ramp Time is effectuated and will be used to ramp down the speed from Motor Speed Low Limit to the Check Valve End Speed in 3-86 Check Valve Ramp End Speed [RPM] or 3-87 Check Valve Ramp End Speed [HZ].	



3-85 Check Valve Ramp Time

Range: **Function:**

Illustration 6.13

3-88 Final Ramp Time

Range: **Function:**

as a fast ramp rate from Motor Speed Low Limit to zero speed.

Illustration 6.16

3-86 Check Valve Ramp End Speed [RPM]

Range: **Function:**

Size related* [0 - par. 4-11 RPM]

Set the speed in [RPM] below Motor Speed Low Limit where the Check Valve is expected to be closed and the Check Valve no longer shall be active.

Illustration 6.14

3-87 Check Valve Ramp End Speed [HZ]

Range: **Function:**

Size related* [0.0 - par. 4-12 Hz]

Set the speed in [Hz] below Motor Speed Low Limit where the Check Valve Ramp will no longer be active.

Illustration 6.15

3-88 Final Ramp Time

Range: **Function:**

0.00 s* [0.00 - 60.00 s]

Enter the Final Ramp Time to be used when ramping down from Motor Speed Low Limit, 4-11 Motor Speed Low Limit [RPM] or 4-12 Motor Speed Low Limit [Hz], to zero speed. Submersible deep well pumps can be damaged by running below minimum speed. A fast ramp time below minimum pump speed is recommended. This parameter may be applied



6.3.3 Limits and Warnings

Parameter group for configuring limits and warnings.

4-11 Motor Speed Low Limit [RPM]		
Range:		Function:
Size related*	[0 - par. 4-13 RPM]	Enter the minimum limit for motor speed. The Motor Speed Low Limit can be set to correspond to the manufacturer's recommended minimum motor speed. The Motor Speed Low Limit must not exceed the setting in <i>4-13 Motor Speed High Limit [RPM]</i> .

4-13 Motor Speed High Limit [RPM]		
Range:		Function:
Size related*	[par. 4-11 - 60000. RPM]	Enter the maximum limit for motor speed. The Motor Speed High Limit can be set to correspond to the manufacturer's maximum rated motor. The Motor Speed High Limit must exceed the setting in <i>4-11 Motor Speed Low Limit [RPM]</i> . Only <i>4-11 Motor Speed Low Limit [RPM]</i> or <i>4-12 Motor Speed Low Limit [Hz]</i> will be displayed depending on other parameters in the Main Menu and depending on default settings dependant on global location.

NOTE

Max. output frequency cannot exceed 10% of the carrier frequency (*14-01 Switching Frequency*).

NOTE

Any changes in *4-13 Motor Speed High Limit [RPM]* will reset the value in *4-53 Warning Speed High* to the same value as set in *4-13 Motor Speed High Limit [RPM]*.

Parameter group for configuring the digital input and output.

5-01 Terminal 27 Mode		
Option:		Function:
[0] *	Input	Defines terminal 27 as a digital input.
[1]	Output	Defines terminal 27 as a digital output.

NOTE

This parameter cannot be changed while the motor is running.



6.3.4 5-1* Digital Inputs

Parameters for configuring the input functions for the input terminals.

The digital inputs are used for selecting various functions in the frequency converter. All digital inputs can be set to the following functions:

Digital input function	Select	Terminal
No operation	[0]	All *term 32, 33
Reset	[1]	All
Coast inverse	[2]	All
Coast and reset inverse	[3]	All
DC-brake inverse	[5]	All
Stop inverse	[6]	All
External interlock	[7]	All
Start	[8]	All *term 18
Latched start	[9]	All
Reversing	[10]	All *term 19
Start reversing	[11]	All
Jog	[14]	All *term 29
Preset reference on	[15]	All
Preset ref bit 0	[16]	All
Preset ref bit 1	[17]	All
Preset ref bit 2	[18]	All
Freeze reference	[19]	All
Freeze output	[20]	All
Speed up	[21]	All
Speed down	[22]	All
Set-up select bit 0	[23]	All
Set-up select bit 1	[24]	All
Pulse input	[32]	term 29, 33
Ramp bit 0	[34]	All
Mains failure inverse	[36]	All
Run Permissive	[52]	
Hand start	[53]	
Auto start	[54]	
DigiPot Increase	[55]	All
DigiPot Decrease	[56]	All
DigiPot Clear	[57]	All
Counter A (up)	[60]	29, 33
Counter A (down)	[61]	29, 33
Reset Counter A	[62]	All
Counter B (up)	[63]	29, 33
Counter B (down)	[64]	29, 33
Reset Counter B	[65]	All
Sleep Mode	[66]	
Reset Maintenance Word	[78]	
Lead Pump Start	[120]	
Lead Pump Alternation	[121]	
Pump 1 Interlock	[130]	
Pump 2 Interlock	[131]	
Pump 3 Interlock	[132]	

Table 6.15



All = Terminals 18, 19, 27, 29, 32, X30/2, X30/3, X30/4. X30/ are the terminals on MCB 101.

Functions dedicated to only one digital input are stated in the associated parameter.

All digital inputs can be programmed to these functions:

[0]	No operation	No reaction to signals transmitted to terminal.
[1]	Reset	Resets frequency converter after a TRIP/ALARM. Not all alarms can be reset.
[2]	Coast inverse	Leaves motor in free mode. Logic '0' => coasting stop. (Default Digital input 27): Coasting stop, inverted input (NC).
[3]	Coast and reset inverse	Reset and coasting stop Inverted input (NC). Leaves motor in free mode and resets the frequency converter. Logic '0' => coasting stop and reset.
[5]	DC-brake inverse	Inverted input for DC braking (NC). Stops motor by energizing it with a DC current for a certain time period. See 2-01 DC Brake Current to 2-03 DC Brake Cut In Speed [RPM]. The function is only active when the value in 2-02 DC Braking Time is different from 0. Logic '0' => DC braking.
[6]	Stop inverse	Stop Inverted function. Generates a stop function when the selected terminal goes from logical level '1' to '0'. The stop is performed according to the selected ramp time (3-42 Ramp 1 Ramp Down Time and 3-52 Ramp 2 Ramp Down Time). When the frequency converter is at the torque limit and has received a stop command, it may not stop by itself. To ensure that the frequency converter stops, configure a digital output to <i>Torque limit & stop</i> [27] and connect this digital output to a digital input that is configured as coast.
[7]	External Interlock	Same function as Coasting stop, inverse, but External Interlock generates the alarm message 'external fault' on the display when the terminal which is programmed for Coast Inverse is logic '0'. The alarm message will also be active via digital outputs and relay outputs, if programmed for External Interlock. The alarm can be reset using a digital input or the [RESET] key if the cause for the External Interlock has been removed. A delay can be programmed in 22-00 External Interlock Delay. After applying a signal to the input, the reaction described above will be delayed with the time set in 22-00 External Interlock Delay.

[8]	Start	Select start for a start/stop command. Logic '1' = start, logic '0' = stop. (Default Digital input 18)																																				
[9]	Latched start	Motor starts, if a pulse is applied for min. 2 ms. Motor stops when Stop inverse is activated																																				
[10]	Reversing	Changes direction of motor shaft rotation. Select Logic '1' to reverse. The reversing signal only changes the direction of rotation. It does not activate the start function. Select both directions in 4-10 Motor Speed Direction. (Default Digital input 19).																																				
[11]	Start reversing	Used for start/stop and for reversing on the same wire. Signals on start are not allowed at the same time.																																				
[14]	Jog	Used for activating jog speed. See 3-11 Jog Speed [Hz]. (Default Digital input 29)																																				
[15]	Preset reference on	Used for shifting between external reference and preset reference. It is assumed that <i>External/preset</i> [1] has been selected in 3-04 Reference Function. Logic '0' = external reference active; logic '1' = one of the eight preset references is active.																																				
[16]	Preset ref bit 0	Enables a choice between one of the eight preset references according to the table below.																																				
[17]	Preset ref bit 1	Enables a choice between one of the eight preset references according to the table below.																																				
[18]	Preset ref bit 2	Enables a choice between one of the eight preset references according to the table below. <table border="1" data-bbox="1037 1366 1445 1675"> <thead> <tr> <th>Preset ref. bit</th> <th>2</th> <th>1</th> <th>0</th> </tr> </thead> <tbody> <tr> <td>Preset ref. 0</td> <td>0</td> <td>0</td> <td>0</td> </tr> <tr> <td>Preset ref. 1</td> <td>0</td> <td>0</td> <td>1</td> </tr> <tr> <td>Preset ref. 2</td> <td>0</td> <td>1</td> <td>0</td> </tr> <tr> <td>Preset ref. 3</td> <td>0</td> <td>1</td> <td>1</td> </tr> <tr> <td>Preset ref. 4</td> <td>1</td> <td>0</td> <td>0</td> </tr> <tr> <td>Preset ref. 5</td> <td>1</td> <td>0</td> <td>1</td> </tr> <tr> <td>Preset ref. 6</td> <td>1</td> <td>1</td> <td>0</td> </tr> <tr> <td>Preset ref. 7</td> <td>1</td> <td>1</td> <td>1</td> </tr> </tbody> </table> Table 6.16	Preset ref. bit	2	1	0	Preset ref. 0	0	0	0	Preset ref. 1	0	0	1	Preset ref. 2	0	1	0	Preset ref. 3	0	1	1	Preset ref. 4	1	0	0	Preset ref. 5	1	0	1	Preset ref. 6	1	1	0	Preset ref. 7	1	1	1
Preset ref. bit	2	1	0																																			
Preset ref. 0	0	0	0																																			
Preset ref. 1	0	0	1																																			
Preset ref. 2	0	1	0																																			
Preset ref. 3	0	1	1																																			
Preset ref. 4	1	0	0																																			
Preset ref. 5	1	0	1																																			
Preset ref. 6	1	1	0																																			
Preset ref. 7	1	1	1																																			
[19]	Freeze ref	Freezes actual reference. The frozen reference is now the point of enable/condition for Speed up and Speed down to be used. If Speed up/down is used, the speed change always follows ramp 2 (3-51 Ramp 2 Ramp Up Time and 3-52 Ramp 2 Ramp Down Time) in the range 0 - 3-03 Maximum Reference Maximum Reference.																																				



[20]	Freeze output	Freezes actual motor frequency (Hz). The frozen motor frequency is now the point of enable/condition for Speed up and Speed down to be used. If Speed up/down is used, the speed change always follows ramp 2 (3-51 Ramp 2 Ramp Up Time and 3-52 Ramp 2 Ramp Down Time) in the range 0 - 1-23 Motor Frequency. When Freeze output is active, the frequency converter cannot be stopped via a low 'start [13]' signal. Stop the frequency converter via a terminal programmed for Coasting inverse [2] or Coast and reset, inverse [3].
[21]	Speed up	For digital control of the up/down speed is desired (motor potentiometer). Activate this function by selecting either Freeze reference or Freeze output. When Speed up is activated for less than 400 msec. the resulting reference will be increased by 0.1 %. If Speed up is activated for more than 400 msec. the resulting reference will ramp according to Ramp 1 in 3-41 Ramp 1 Ramp Up Time.
[22]	Speed down	Same as Speed up [21].
[23]	Set-up select bit 0	Selects one of the four set-ups. Set 0-10 Active Set-up to Multi Set-up.
[24]	Set-up select bit 1	Same as Set-up select bit 0 [23]. (Default Digital input 32)
[32]	Pulse input	Select Pulse input when using a pulse sequence as either reference or feedback. Scaling is done in parameter group 5-5*.
[34]	Ramp bit 0	Select which ramp to use. Logic "0" will select ramp 1 while logic "1" will select ramp 2.
[36]	Mains failure inverse	Activates 14-10 Mains Failure. Mains failure inverse is active in the Logic "0" situation.
[52]	Run Permissive	The input terminal, for which the Run permissive has been programmed must be logic "1" before a start command can be accepted. Run permissive has a logic 'AND' function related to the terminal which is programmed for [8] Start, [14] Jog or [20] Freeze Output, which means that in order to start running the motor, both conditions must be fulfilled. If Run Permissive is programmed on multiple terminals, Run permissive needs only be logic '1' on one of the terminals for the function to be carried out. The digital output signal for Run Request ([8] Start, [14] Jog or [20] Freeze output) programmed in parameter group 5-3* Digital outputs, or parameter group 5-4* Relays, will not be affected by Run Permissive.
[53]	Hand start	A signal applied will put the frequency converter into Hand mode as if button

		[Hand On] on the LCP has been pressed and a normal stop command will be overridden. If disconnecting the signal, the motor will stop. To make any other start commands valid, another digital input must be assign to Auto Start and a signal applied to this. The [Hand On] and [Auto On] buttons on the LCP has no impact. The Off button on the LCP will override Hand Start and Auto Start. Press either the [Hand On] or [Auto On] button to make Hand Start and Auto Start active again. If no signal on neither Hand Start nor Auto Start, the motor will stop regardless of any normal Start command applied. If signal applied to both Hand Start and Auto Start, the function will be Auto Start. If pressing [Off] on the LCP the motor will stop regardless of signals on Hand Start and Auto Start.
[54]	Auto start	A signal applied will put the frequency converter into Auto mode as if the LCP key [Auto On] has been pressed. See also [53] Hand Start
[55]	DigiPot Increase	Uses the input as an INCREASE signal to the Digital Potentiometer function described in parameter group 3-9*
[56]	DigiPot Decrease	Uses the input as a DECREASE signal to the Digital Potentiometer function described in parameter group 3-9*
[57]	DigiPot Clear	Uses the input to CLEAR the Digital Potentiometer reference described in parameter group 3-9*
[60]	Counter A (up)	(Terminal 29 or 33 only) Input for increment counting in the SLC counter.
[61]	Counter A (down)	(Terminal 29 or 33 only) Input for decrement counting in the SLC counter.
[62]	Reset Counter A	Input for reset of counter A.
[63]	Counter B (up)	(Terminal 29 and 33 only) Input for increment counting in the SLC counter.
[64]	Counter B (down)	(Terminal 29 and 33 only) Input for decrement counting in the SLC counter.
[65]	Reset Counter B	Input for reset of counter B.
[66]	Sleep Mode	Forces frequency converter into Sleep Mode (see parameter group 22-4*, Sleep Mode). Reacts on the rising edge of signal applied!
[78]	Reset Preventive Maintenance Word	Resets all data in 16-96 Maintenance Word to 0.

The below setting options are all related to the Cascade Controller. Wiring diagrams and settings for parameter, see parameter group 25-** for more details.



[120]	Lead Pump Start	Starts/Stops the Lead Pump (controlled by the frequency converter). A start requires that also a System Start signal has been applied e.g. to one of the digital inputs set for [8] Start!																																
[121]	Lead Pump Alternation	Forces alternation of the lead pump in a Cascade Controller. <i>Lead Pump Alternation, 25-50 Lead Pump Alternation</i> must be set to either [2] At Command or [3] At Staging or At Command. <i>Alternation Event, 25-51 Alternation Event</i> can be set to any of the four options.																																
[130 - 138]	Pump1 Interlock - Pump9 Interlock	<p>The function will depend on the setting in 25-06 Number of Pumps. If set to [0] No, then Pump1 refers to the pump controlled by relay RELAY1 etc. If set to [1] Yes, Pump1 refers to the pump controlled by the frequency converter only (without any of the build in relays involved) and Pump2 to the pump controlled by the relay RELAY1. Variable speed pump (lead) cannot be interlocked in the basic Cascade Controller. See Table 6.17</p> <table border="1" style="width: 100%; border-collapse: collapse;"> <thead> <tr> <th rowspan="2">Setting in parameter group 5-1*</th> <th colspan="2">Setting in 25-06 Number of Pumps</th> </tr> <tr> <th>[0] No</th> <th>[1] Yes</th> </tr> </thead> <tbody> <tr> <td>[130] Pump1 Interlock</td> <td>Controlled by RELAY1 (only if not lead pump)</td> <td>Frequency Converter controlled (cannot be interlocked)</td> </tr> <tr> <td>[131] Pump2 Interlock</td> <td>Controlled by RELAY2</td> <td>Controlled by RELAY1</td> </tr> <tr> <td>[132] Pump3 Interlock</td> <td>Controlled by RELAY3</td> <td>Controlled by RELAY2</td> </tr> <tr> <td>[133] Pump4 Interlock</td> <td>Controlled by RELAY4</td> <td>Controlled by RELAY3</td> </tr> <tr> <td>[134] Pump5 Interlock</td> <td>Controlled by RELAY5</td> <td>Controlled by RELAY4</td> </tr> <tr> <td>[135] Pump6 Interlock</td> <td>Controlled by RELAY6</td> <td>Controlled by RELAY5</td> </tr> <tr> <td>[136] Pump7 Interlock</td> <td>Controlled by RELAY7</td> <td>Controlled by RELAY6</td> </tr> <tr> <td>[137] Pump8 Interlock</td> <td>Controlled by RELAY8</td> <td>Controlled by RELAY7</td> </tr> <tr> <td>[138] Pump9 Interlock</td> <td>Controlled by RELAY9</td> <td>Controlled by RELAY8</td> </tr> </tbody> </table> <p style="text-align: center;">Table 6.17</p>	Setting in parameter group 5-1*	Setting in 25-06 Number of Pumps		[0] No	[1] Yes	[130] Pump1 Interlock	Controlled by RELAY1 (only if not lead pump)	Frequency Converter controlled (cannot be interlocked)	[131] Pump2 Interlock	Controlled by RELAY2	Controlled by RELAY1	[132] Pump3 Interlock	Controlled by RELAY3	Controlled by RELAY2	[133] Pump4 Interlock	Controlled by RELAY4	Controlled by RELAY3	[134] Pump5 Interlock	Controlled by RELAY5	Controlled by RELAY4	[135] Pump6 Interlock	Controlled by RELAY6	Controlled by RELAY5	[136] Pump7 Interlock	Controlled by RELAY7	Controlled by RELAY6	[137] Pump8 Interlock	Controlled by RELAY8	Controlled by RELAY7	[138] Pump9 Interlock	Controlled by RELAY9	Controlled by RELAY8
Setting in parameter group 5-1*	Setting in 25-06 Number of Pumps																																	
	[0] No	[1] Yes																																
[130] Pump1 Interlock	Controlled by RELAY1 (only if not lead pump)	Frequency Converter controlled (cannot be interlocked)																																
[131] Pump2 Interlock	Controlled by RELAY2	Controlled by RELAY1																																
[132] Pump3 Interlock	Controlled by RELAY3	Controlled by RELAY2																																
[133] Pump4 Interlock	Controlled by RELAY4	Controlled by RELAY3																																
[134] Pump5 Interlock	Controlled by RELAY5	Controlled by RELAY4																																
[135] Pump6 Interlock	Controlled by RELAY6	Controlled by RELAY5																																
[136] Pump7 Interlock	Controlled by RELAY7	Controlled by RELAY6																																
[137] Pump8 Interlock	Controlled by RELAY8	Controlled by RELAY7																																
[138] Pump9 Interlock	Controlled by RELAY9	Controlled by RELAY8																																

5-13 Terminal 29 Digital Input		
Option:	Function:	
[0] *	No Operation	Same options and functions as parameter group 5-1* Digital Inputs.

E-05 Terminal 32 Digital Input		
Option:	Function:	
[0] *	No Operation	Same options and functions as parameter group E-0# and E-5# Digital Inputs, except for Pulse input.

E-06 Terminal 33 Digital Input		
Option:	Function:	
[0] *	No Operation	Same options and functions as parameter group E-0# and E-5# Digital Inputs.

5-30 Terminal 27 Digital Output		
Same options and functions as parameter group 5-3*.		
Option:	Function:	
[0] *	No operation	

5-40 Function Relay		
Option:	Function:	
		Select options to define the function of the relays. The selection of each mechanical relay is realized in an array parameter.
[0] *	No operation	
[1]	Control ready	
[2]	Drive ready	
[3]	Drive rdy/rem ctrl	
[4]	Stand-by / no warning	
[5]	Running	
[6]	Running / no warning	
[8]	Run on ref/no warn	
[9]	Alarm	
[10]	Alarm or warning	
[11]	At torque limit	
[12]	Out of current range	
[13]	Below current, low	
[14]	Above current, high	
[15]	Out of speed range	
[16]	Below speed, low	
[17]	Above speed, high	
[18]	Out of feedb. range	
[19]	Below feedback, low	
[20]	Above feedback, high	
[21]	Thermal warning	
[25]	Reverse	
[26]	Bus OK	
[27]	Torque limit & stop	
[28]	Brake, no brake war	
[29]	Brake ready, no fault	
[30]	Brake fault (IGBT)	
[35]	External Interlock	
[36]	Control word bit 11	
[37]	Control word bit 12	
[40]	Out of ref range	



5-40 Function Relay	
Option:	Function:
[41]	Below reference, low
[42]	Above ref, high
[45]	Bus ctrl.
[46]	Bus ctrl, 1 if timeout
[47]	Bus ctrl, 0 if timeout
[60]	Comparator 0
[61]	Comparator 1
[62]	Comparator 2
[63]	Comparator 3
[64]	Comparator 4
[65]	Comparator 5
[70]	Logic rule 0
[71]	Logic rule 1
[72]	Logic rule 2
[73]	Logic rule 3
[74]	Logic rule 4
[75]	Logic rule 5
[80]	SL digital output A
[81]	SL digital output B
[82]	SL digital output C
[83]	SL digital output D
[84]	SL digital output E
[85]	SL digital output F
[160]	No alarm
[161]	Running reverse
[165]	Local ref active
[166]	Remote ref active
[167]	Start command act.
[168]	Hand mode
[169]	Auto mode
[180]	Clock Fault
[181]	Prev. Maintenance
[188]	AHF Capacitor Connect
[189]	External Fan Control
[190]	No-Flow
[191]	Dry Pump
[192]	End Of Curve
[193]	Sleep Mode
[194]	Broken Belt
[195]	Bypass Valve Control
[198]	Drive Bypass
[199]	Pipe Filling
[211]	Cascade Pump 1
[212]	Cascade Pump 2
[213]	Cascade Pump 3
[214]	Cascade Pump 4
[215]	Cascade Pump 5
[216]	Cascade Pump 6
[217]	Cascade Pump 7
[218]	Cascade Pump 8
[219]	Cascade Pump 9
[230]	Ext. Cascade Ctrl

5-53 Term. 29 High Ref./Feedb. Value	
Range:	Function:
100.000 * [-999999.999 - 999999.999]	Enter the high reference value [RPM] for the motor shaft speed and the high feedback value, see also 5-58 Term. 33 High Ref./Feedb. Value.



6.3.5 AN-## Analog In/Out

Parameter group for configuration of the analog input and output.

6

6-00 Live Zero Timeout Time		
Range:	Function:	
10 s* [1 - 99 s]	Enter the Live Zero Time-out time period. Live Zero Time-out Time is active for analog inputs, i.e. terminal 53 or terminal 54, used as reference or feedback sources. If the reference signal value associated with the selected current input falls below 50% of the value set in <i>6-10 Terminal 53 Low Voltage</i> , <i>6-12 Terminal 53 Low Current</i> , <i>6-20 Terminal 54 Low Voltage</i> or <i>6-22 Terminal 54 Low Current</i> for a time period longer than the time set in <i>6-00 Live Zero Timeout Time</i> , the function selected in <i>6-01 Live Zero Timeout Function</i> will be activated.	

6-01 Live Zero Timeout Function		
Option:	Function:	
	Select the time-out function. The function set in <i>6-01 Live Zero Timeout Function</i> will be activated if the input signal on terminal 53 or 54 is below 50% of the value in <i>6-10 Terminal 53 Low Voltage</i> , <i>6-12 Terminal 53 Low Current</i> , <i>6-20 Terminal 54 Low Voltage</i> or <i>6-22 Terminal 54 Low Current</i> for a time period defined in <i>6-00 Live Zero Timeout Time</i> . If several time-outs occur simultaneously, the frequency converter prioritises the time-out functions as follows <ol style="list-style-type: none"> 1. <i>6-01 Live Zero Timeout Function</i> 2. <i>8-04 Control Timeout Function</i> The output frequency of the frequency converter can be: <ul style="list-style-type: none"> • [1] frozen at the present value • [2] overruled to stop • [3] overruled to jog speed • [4] overruled to max. speed • [5] overruled to stop with subsequent trip 	
[0] *	Off	
[1]	Freeze output	
[2]	Stop	
[3]	Jogging	
[4]	Max. speed	
[5]	Stop and trip	

6-10 Terminal 53 Low Voltage		
Range:	Function:	
0.07 V* [0.00 - par. 6-11 V]	Enter the low voltage value. This analog input scaling value should correspond to the low reference/feedback value set in <i>6-14 Terminal 53 Low Ref./Feedb. Value</i> .	

6-11 Terminal 53 High Voltage		
Range:	Function:	
10.00 V* [par. 6-10 - 10.00 V]	Enter the high voltage value. This analog input scaling value should correspond to the high reference/feedback value set in <i>6-15 Terminal 53 High Ref./Feedb. Value</i> .	

6-14 Terminal 53 Low Ref./Feedb. Value		
Range:	Function:	
0.000 * [-999999.999 - 999999.999]	Enter the analog input scaling value that corresponds to the low voltage/low current set in <i>6-10 Terminal 53 Low Voltage</i> and <i>6-12 Terminal 53 Low Current</i> .	

6-15 Terminal 53 High Ref./Feedb. Value		
Range:	Function:	
Size related* [-999999.999 - 999999.999]	Enter the analog input scaling value that corresponds to the high voltage/high current value set in <i>6-11 Terminal 53 High Voltage</i> and <i>6-13 Terminal 53 High Current</i> .	

6-20 Terminal 54 Low Voltage		
Range:	Function:	
0.07 V* [0.00 - par. 6-21 V]	Enter the low voltage value. This analog input scaling value should correspond to the low reference/feedback value, set in <i>6-24 Terminal 54 Low Ref./Feedb. Value</i> .	

6-21 Terminal 54 High Voltage		
Range:	Function:	
10.00 V* [par. 6-20 - 10.00 V]	Enter the high voltage value. This analog input scaling value should correspond to the high reference/feedback value set in <i>6-25 Terminal 54 High Ref./Feedb. Value</i> .	

6-24 Terminal 54 Low Ref./Feedb. Value		
Range:	Function:	
0.000 * [-999999.999 - 999999.999]	Enter the analog input scaling value that corresponds to the low voltage/low current value set in <i>6-20 Terminal 54 Low Voltage</i> and <i>6-22 Terminal 54 Low Current</i> .	



6-25 Terminal 54 High Ref./Feedb. Value		
Range:	Function:	
100.000 * [-999999.999 - 999999.999]	Enter the analog input scaling value that corresponds to the high voltage/high current value set in 6-21 Terminal 54 High Voltage and 6-23 Terminal 54 High Current.	

6-50 Terminal 42 Output		
Option:	Function:	
	Select the function of Terminal 42 as an analog current output. A motor current of 20 mA corresponds to I _{max} .	
[0]	No operation	
[100]	Output freq. 0-100	0 - 100 Hz, (0-20 mA)
[101]	Reference Min-Max	Minimum reference - Maximum reference, (0-20 mA)
[102]	Feedback +-200%	-200% to +200% of 20-14 Maximum Reference/Feedb., (0-20 mA)
[103]	Motor cur. 0-I _{max}	0 - Inverter Max. Current (16-37 Inv. Max. Current), (0-20 mA)
[104]	Torque 0-T _{lim}	0 - Torque limit (4-16 Torque Limit Motor Mode), (0-20 mA)
[105]	Torque 0-T _{nom}	0 - Motor rated torque, (0-20 mA)
[106]	Power 0-P _{nom}	0 - Motor rated power, (0-20 mA)
[107]	Speed 0-HighLim	0 - Speed High Limit (4-13 Motor Speed High Limit [RPM] and 4-14 Motor Speed High Limit [Hz]), (0-20 mA)
[108]	Torque +-160%	
[109]	Out frq 0-F _{max}	
[113]	Ext. Closed Loop 1	0 - 100%, (0-20 mA)
[114]	Ext. Closed Loop 2	0 - 100%, (0-20 mA)
[115]	Ext. Closed Loop 3	0 - 100%, (0-20 mA)
[116]	Cascade Reference	
[130]	Out frq 0-100 4-20mA	0 - 100 Hz
[131]	Reference 4-20mA	Minimum Reference - Maximum Reference
[132]	Feedback 4-20mA	-200% to +200% of 20-14 Maximum Reference/Feedb.
[133]	Motor cur. 4-20mA	0 - Inverter Max. Current (16-37 Inv. Max. Current)
[134]	Torq,0-lim 4-20 mA	0 - Torque limit (4-16 Torque Limit Motor Mode)
[135]	Torq,0-nom 4-20 mA	0 - Motor rated torque

6-50 Terminal 42 Output		
Option:	Function:	
[136]	Power 4-20mA	0 - Motor rated power
[137] *	Speed 4-20mA	0 - Speed High Limit (F-18 and F-15)
[138]	Torque 4-20mA	
[139]	Bus ctrl.	0 - 100%, (0-20 mA)
[140]	Bus ctrl. 4-20 mA	0 - 100%
[141]	Bus ctrl t.o.	0 - 100%, (0-20 mA)
[142]	Bus ctrl t.o. 4-20mA	0 - 100%
[143]	Ext. CL 1 4-20mA	0 - 100%
[144]	Ext. CL 2 4-20mA	0 - 100%
[145]	Ext. CL 3 4-20mA	0 - 100%
[146]	Cascade Ref. 4-20mA	
[150]	Out frq 0-F _{max} 4-20mA	

NOTE

Values for setting the Minimum Reference is found in open loop 3-02 Minimum Reference and for closed loop 20-13 Minimum Reference/Feedb. - values for maximum reference for open loop is found in 3-03 Maximum Reference and for closed loop 20-14 Maximum Reference/Feedb.

6-51 Terminal 42 Output Min Scale		
Range:	Function:	
0.00 %* [0.00 - 200.00 %]	Scale for the minimum output (0 or 4mA) of the analog signal at terminal 42. Set the value to be the percentage of the full range of the variable selected in 6-50 Terminal 42 Output.	

6-52 Terminal 42 Output Max Scale		
Range:	Function:	
100.00 %*	[0.00 - 200.00 %]	Scale for the maximum output (20 mA) of the analog signal at terminal 42. Set the value to be the percentage of the full range of the variable selected in 6-50 Terminal 42 Output.

Illustration 6.17

It is possible to get a value lower than 20 mA at full scale by programming values >100% by using a formula as follows:

$20 \text{ mA} \mid \text{desired maximum current} \times 100 \%$

i.e. $10 \text{ mA} : \frac{20 \text{ mA}}{10 \text{ mA}} \times 100 \% = 200 \%$

EXAMPLE 1:

Variable value= OUTPUT FREQUENCY, range = 0-100 Hz

Range needed for output = 0-50 Hz

Output signal 0 or 4 mA is needed at 0 Hz (0% of range) - set 6-51 Terminal 42 Output Min Scale to 0%

Output signal 20 mA is needed at 50 Hz (50% of range) - set 6-52 Terminal 42 Output Max Scale to 50%

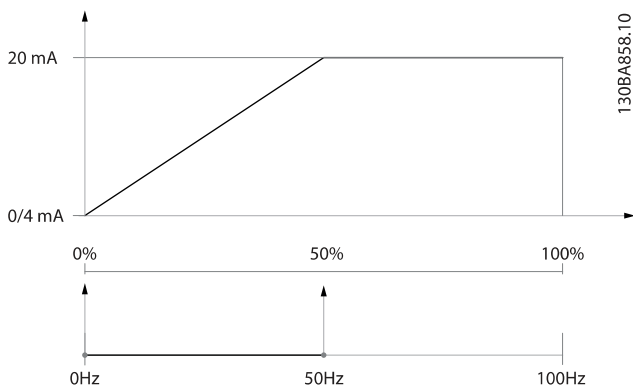

Illustration 6.18

EXAMPLE 2:

Variable= FEEDBACK, range= -200% to +200%

Range needed for output= 0-100%

Output signal 0 or 4 mA is needed at 0% (50% of range) - set 6-51 Terminal 42 Output Min Scale to 50%

Output signal 20 mA is needed at 100% (75% of range) - set 6-52 Terminal 42 Output Max Scale to 75%

EXAMPLE 3:

Variable value= REFERENCE, range= Min ref - Max ref

Range needed for output= Min ref (0%) - Max ref (100%), 0-10 mA

Output signal 0 or 4 mA is needed at Min ref - set 6-51 Terminal 42 Output Min Scale to 0%

Output signal 10 mA is needed at Max ref (100% of range) - set 6-52 Terminal 42 Output Max Scale to 200% (20 mA/10 mA x 100%=200%).

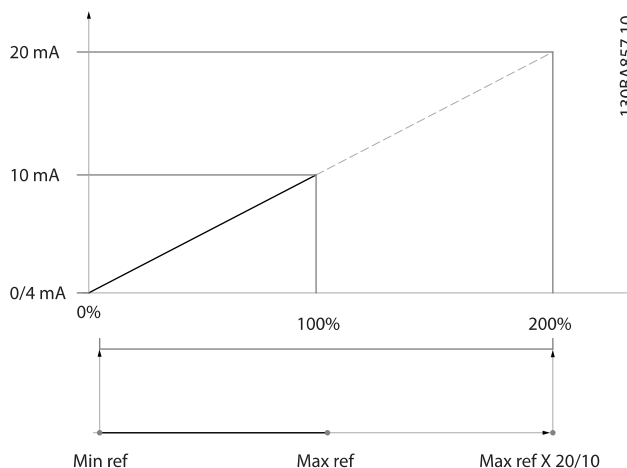

Illustration 6.19

6.3.6 Drive Closed Loop, 20-**

This parameter group is used for configuring the closed loop PID Controller, that controls the output frequency of the frequency converter.

20-12 Reference/Feedback Unit		
Option:	Function:	
[0]		
[1] *	%	
[5]	PPM	
[10]	1/min	
[11]	RPM	
[12]	Pulse/s	
[20]	l/s	
[21]	l/min	
[22]	l/h	
[23]	m ³ /s	
[24]	m ³ /min	
[25]	m ³ /h	
[30]	kg/s	
[31]	kg/min	
[32]	kg/h	
[33]	t/min	
[34]	t/h	
[40]	m/s	
[41]	m/min	
[45]	m	
[60]	°C	



20-12 Reference/Feedback Unit		
Option:	Function:	
[70]	mbar	
[71]	bar	
[72]	Pa	
[73]	kPa	
[74]	m WG	
[75]	mm Hg	
[80]	kW	
[120]	GPM	
[121]	gal/s	
[122]	gal/min	
[123]	gal/h	
[124]	CFM	
[125]	ft ³ /s	
[126]	ft ³ /min	
[127]	ft ³ /h	
[130]	lb/s	
[131]	lb/min	
[132]	lb/h	
[140]	ft/s	
[141]	ft/min	
[145]	ft	
[160]	°F	
[170]	psi	
[171]	lb/in ²	
[172]	in WG	
[173]	ft WG	
[174]	in Hg	
[180]	HP	This parameter determines the unit that is used for the setpoint reference and feedback that the PID Controller will use for controlling the output frequency of the frequency converter.

20-21 Setpoint 1		
Range:	Function:	
0.000 ProcessCtrlUnit*	[-999999.999 - 999999.999 ProcessCtrlUnit]	Setpoint 1 is used in Closed Loop Mode to enter a setpoint reference that is used by the frequency converter's PID Controller. See the description of 20-20 Feedback Function. NOTE Setpoint reference entered here is added to any other references that are enabled (see C-30 and C-34).

20-81 PID Normal/ Inverse Control		
Option:	Function:	
[0] *	Normal	[0] Normal causes the frequency converter's output frequency to decrease when the feedback is greater than the setpoint reference. This is common for pressure-controlled supply fan and pump applications.
[1]	Inverse	[1] Inverse causes the frequency converter's output frequency to increase when the feedback is greater than the setpoint reference.

20-82 PID Start Speed [RPM]		
Range:	Function:	
Size related*	[0 - par. 4-13 RPM]	When the frequency converter is first started, it initially ramps up to this output speed in Open Loop Mode, following the active Ramp Up Time. When the output speed programmed here is reached, the frequency converter will automatically switch to Closed Loop Mode and the PID Controller will begin to function. This is useful in applications in which the driven load must first quickly accelerate to a minimum speed when it is started. NOTE This parameter will only be visible if 0-02 Motor Speed Unit is set to [0], RPM.

20-93 PID Proportional Gain		
Range:	Function:	
2.00 *	[0.00 - 10.00]	The proportional gain indicates the number of times the error between the set point and the feedback signal is to be applied.

If (Error x Gain) jumps with a value equal to what is set in 20-14 Maximum Reference/Feedb. the PID controller will try to change the output speed equal to what is set in 4-13 Motor Speed High Limit [RPM]/4-14 Motor Speed High Limit [Hz] but in practice of course limited by this setting. The proportional band (error causing output to change from 0-100%) can be calculated by means of the formula

$$\left(\frac{1}{\text{Proportional Gain}} \right) \times (\text{Max Reference})$$



20-94 PID Integral Time		
Range:	Function:	
8.00 s*	[0.01 - 10000.00 s]	Over time, the integrator accumulates a contribution to the output from the PID controller as long as there is a deviation between the Reference/Setpoint and feedback signals. The contribution is proportional to the size of the deviation. This ensures that the deviation (error) approaches zero. Quick response on any deviation is obtained when the integral time is set to a low value. Setting it too low, however, may cause the control to become unstable. The value set, is the time needed for the integrator to add the same contribution as the proportional for a certain deviation. If the value is set to 10,000, the controller will act as a pure proportional controller with a P-band based on the value set in 20-93 PID Proportional Gain. When no deviation is present, the output from the proportional controller will be 0.

6.3.7 22-** Miscellaneous

This group contains parameters used for monitoring water/wastewater applications.

22-20 Low Power Auto Set-up		
Start of auto set-up of power data for No-Flow Power tuning.		
Option:	Function:	
[0] * Off		
[1] Enabled	When set for <i>Enabled</i> , an auto set up sequence is activated, automatically setting speed to approx. 50 and 85% of rated motor speed (4-13 Motor Speed High Limit [RPM], 4-14 Motor Speed High Limit [Hz]). At those two speeds, the power consumption is automatically measured and stored. Before enabling Auto Set Up: <ol style="list-style-type: none"> Close valve(s) in order to create a no flow condition The frequency converter must be set for Open Loop (1-00 Configuration Mode). Note that it is important also to set 1-03 Torque Characteristics. 	

NOTE

Auto Set-up must be done when the system has reached normal operating temperature!

NOTE

It is important that the 4-13 Motor Speed High Limit [RPM] or 4-14 Motor Speed High Limit [Hz] is set to the max. operational speed of the motor!

It is important to do the Auto Set-up before configuring the integrated PI Controller as settings will be reset when changing from Closed to Open Loop in 1-00 Configuration Mode.

NOTE

Carry out the tuning with the same settings in 1-03 Torque Characteristics, as for operation after the tuning.

22-21 Low Power Detection		
Option:	Function:	
[0] * Disabled		
[1] Enabled	If selecting Enabled, the Low Power Detection commissioning must be carried out in order to set the parameters in parameter group AP-3# for proper operation!	

22-22 Low Speed Detection		
Option:	Function:	
[0] * Disabled		
[1] Enabled	Select Enabled for detecting when the motor operates with a speed as set in 4-11 Motor Speed Low Limit [RPM] or 4-12 Motor Speed Low Limit [Hz].	

22-23 No-Flow Function		
Common actions for Low Power Detection and Low Speed Detection (Individual selections not possible).		
Option:	Function:	
[0] * Off	The frequency converter will not respond to a No Flow condition.	
[1] Sleep Mode	The frequency converter will enter Sleep Mode and stop when a No Flow condition is detected. See parameter group AP-4# for programming options for Sleep Mode.	
[2] Warning	The frequency converter will continue to run, but activate a No-Flow Warning [W92]. A drive digital output or a serial communication bus can communicate a warning to other equipment.	
[3] Alarm	The frequency converter will stop running and activate a No-Flow Alarm [A 92]. A frequency converter digital output or a serial communication bus can communicate an alarm to other equipment.	



NOTE

Do not set 14-20 *Reset Mode*, to [13] *Infinite auto reset*, when 22-23 *No-Flow Function* is set to [3] *Alarm*. Doing so will cause the frequency converter to continuously cycle between running and stopping when a No Flow condition is detected.

NOTE

If the frequency converter is equipped with a constant speed bypass with an automatic bypass function that starts the bypass if the frequency converter experiences a persistent alarm condition, be sure to disable the bypass's automatic bypass function, if [3] *Alarm* is selected as the No-Flow Function.

22-24 No-Flow Delay		
Range:	Function:	
10 s*	[1 - 600 s]	Set the time Low Power/Low Speed must stay detected to activate signal for actions. If detection disappears before run out of the timer, the timer will be reset.

22-26 Dry Pump Function		
Select desired action for dry pump operation.		
Option:	Function:	
[0] *	Off	
[1]	Warning	The frequency converter will continue to run, but activate a Dry pump warning [W93]. A frequency converter digital output or a serial communication bus can communicate a warning to other equipment.
[2]	Alarm	The frequency converter will stop running and activate a Dry pump alarm [A93]. A frequency converter digital output or a serial communication bus can communicate an alarm to other equipment.
[3]	Manual Reset Alarm	The frequency converter will stop running and activate a Dry pump alarm [A93]. A frequency converter digital output or a serial communication bus can communicate an alarm to other equipment.

NOTE

Low Power Detection must be Enabled (22-21 Low Power Detection) and commissioned (using either parameter group AP-3#, No Flow Power Tuning, or 22-20 Low Power Auto Set-up) in order to use Dry Pump Detection.

NOTE

Do not set 14-20 *Reset Mode*, to [13] *Infinite auto reset*, when 22-26 *Dry Pump Function* is set to [2] *Alarm*. Doing so will cause the frequency converter to continuously cycle between running and stopping when a Dry Pump condition is detected.

NOTE

If the frequency converter is equipped with a constant speed bypass with an automatic bypass function that starts the bypass if the frequency converter experiences a persistent alarm condition, be sure to disable the bypass's automatic bypass function, if [2] *Alarm* or [3] *Man. Reset Alarm* is selected as the Dry Pump Function.

22-27 Dry Pump Delay		
Range:	Function:	
10 s*	[0 - 600 s]	Defines for how long the Dry Pump condition must be active before activating Warning or Alarm

22-30 No-Flow Power		
Range:	Function:	
0.00 kW*	[0.00 - 0.00 kW]	Read out of calculated No Flow power at actual speed. If power drops to the display value the frequency converter will consider the condition as a No Flow situation.

22-31 Power Correction Factor		
Range:	Function:	
100 %*	[1 - 400 %]	Make corrections to the calculated power at 22-30 <i>No-Flow Power</i> . If No Flow is detected, when it should not be detected, the setting should be decreased. However, if No Flow is not detected, when it should be detected, the setting should be increased to above 100%.

22-32 Low Speed [RPM]		
Range:	Function:	
Size related*	[0 - par. 22-36 RPM]	To be used if 0-02 <i>Motor Speed Unit</i> has been set for RPM (parameter not visible if Hz selected). Set used speed for the 50% level. This function is used for storing values needed to tune No Flow Detection.

22-33 Low Speed [Hz]		
Range:	Function:	
Size related*	[0.0 - par. 22-37 Hz]	To be used if 0-02 <i>Motor Speed Unit</i> has been set for Hz (parameter not visible if RPM selected). Set used speed for the 50% level. The function is used for storing values needed to tune No Flow Detection.



22-34 Low Speed Power [kW]		
Range:	Function:	
Size related*	[0.00 - 0.00 kW]	To be used if <i>0-03 Regional Settings</i> has been set for International (parameter not visible if North America selected). Set power consumption at 50% speed level. This function is used for storing values needed to tune No Flow Detection.

22-35 Low Speed Power [HP]		
Range:	Function:	
Size related*	[0.00 - 0.00 hp]	To be used if <i>0-03 Regional Settings</i> has been set for North America (parameter not visible if International selected). Set power consumption at 50% speed level. This function is used for storing values needed to tune No Flow Detection.

22-36 High Speed [RPM]		
Range:	Function:	
Size related*	[0 - par. 4-13 RPM]	To be used if <i>0-02 Motor Speed Unit</i> has been set for RPM (parameter not visible if Hz selected). Set used speed for the 85% level. The function is used for storing values needed to tune No Flow Detection.

22-37 High Speed [Hz]		
Range:	Function:	
Size related*	[0.0 - par. 4-14 Hz]	To be used if <i>0-02 Motor Speed Unit</i> has been set for Hz (parameter not visible if RPM selected). Set used speed for the 85% level. The function is used for storing values needed to tune No Flow Detection.

22-38 High Speed Power [kW]		
Range:	Function:	
Size related*	[0.00 - 0.00 kW]	To be used if <i>0-03 Regional Settings</i> has been set for International (parameter not visible if North America selected). Set power consumption at 85% speed level. This function is used for storing values needed to tune No Flow Detection.

22-39 High Speed Power [HP]		
Range:	Function:	
Size related*	[0.00 - 0.00 hp]	To be used if <i>0-03 Regional Settings</i> has been set for North America (parameter not visible if International selected). Set power consumption at 85% speed level.

22-39 High Speed Power [HP]		
Range:	Function:	
		This function is used for storing values needed to tune No Flow Detection.

22-40 Minimum Run Time		
Range:	Function:	
60 s*	[0 - 600 s]	Set the desired minimum running time for the motor after a start command (digital input or Bus) before entering Sleep Mode.

22-41 Minimum Sleep Time		
Range:	Function:	
30 s*	[0 - 600 s]	Set the desired Minimum Time for staying in Sleep Mode. This will override any wake up conditions.

22-42 Wake-up Speed [RPM]		
Range:	Function:	
Size related*	[par. 4-11 - par. 4-13 RPM]	To be used if <i>0-02 Motor Speed Unit</i> has been set for RPM (parameter not visible if Hz selected). Only to be used if <i>1-00 Configuration Mode</i> is set for Open Loop and speed reference is applied by an external controller. Set the reference speed at which the Sleep Mode should be cancelled.

22-43 Wake-up Speed [Hz]		
Range:	Function:	
Size related*	[par. 4-12 - par. 4-14 Hz]	To be used if <i>0-02 Motor Speed Unit</i> , has been set for Hz (parameter not visible if RPM selected). Only to be used if <i>1-00 Configuration Mode</i> , is set for Open Loop and speed reference is applied by an external controller controlling the pressure. Set the reference speed at which the Sleep Mode should be cancelled.

22-44 Wake-up Ref./FB Difference		
Range:	Function:	
10 %*	[0 - 100 %]	Only to be used if <i>1-00 Configuration Mode</i> , is set for Closed Loop and the integrated PI controller is used for controlling the pressure. Set the pressure drop allowed in percentage of set point for the pressure (P_{set}) before cancelling the Sleep Mode.



22-44 Wake-up Ref./FB Difference	
Range:	Function:
	<p>NOTE</p> <p>If used in application where the integrated PI controller is set for inverse control in <i>20-71 PID Performance</i>, the value set in <i>22-44 Wake-up Ref./FB Difference</i> will automatically be added.</p>

22-45 Setpoint Boost	
Range:	Function:
0 %* [-100 - 100 %]	<p>Only to be used if <i>1-00 Configuration Mode</i>, is set for Closed Loop and the integrated PI controller is used. In systems with e.g. constant pressure control, it is advantageous to increase the system pressure before the motor is stopped. This will extend the time in which the motor is stopped and help to avoid frequent start/stop.</p> <p>Set the desired over pressure/temperature in percentage of set point for the pressure (P_{set})/temperature before entering the Sleep Mode. If setting for 5%, the boost pressure will be $P_{set} * 1.05$. The negative values can be used for e.g. cooling tower control where a negative change is needed.</p>

22-46 Maximum Boost Time	
Range:	Function:
60 s* [0 - 600 s]	<p>Only to be used if <i>1-00 Configuration Mode</i> is set for Closed Loop and the integrated PI controller is used for controlling the pressure.</p> <p>Set the maximum time for which boost mode will be allowed. If the set time is exceeded, Sleep Mode will be entered, not waiting for the set boost pressure to be reached.</p>

22-50 End of Curve Function	
Option:	Function:
[0] * Off	End of Curve monitoring not active.
[1] Warning	The frequency converter will continue to run, but activate a End of Curve warning [W94]. A frequency converter digital output or a serial communication bus can communicate a warning to other equipment.
[2] Alarm	The frequency converter will stop running and activate a End of Curve alarm [A 94]. A frequency converter digital output or a serial communication bus can communicate an alarm to other equipment.
[3] Manual Reset Alarm	The frequency converter will stop running and activate a End of Curve alarm [A 94]. A frequency converter digital output or a serial

22-50 End of Curve Function	
Option:	Function:
	communication bus can communicate an alarm to other equipment.

NOTE

Automatic restart will reset the alarm and start the system again.

NOTE

Do not set *14-20 Reset Mode*, to *[13] Infinite auto reset*, when *22-50 End of Curve Function* is set to *[2] Alarm*. Doing so will cause the frequency converter to continuously cycle between running and stopping when a End of Curve condition is detected.

NOTE

If the frequency converter is equipped with a constant speed bypass with an automatic bypass function that starts the bypass if the frequency converter experiences a persistent alarm condition, be sure to disable the bypass's automatic bypass function, if *[2] Alarm* or *[3] Man. Reset Alarm* is selected as the End of Curve Function.

22-51 End of Curve Delay	
Range:	Function:
10 s* [0 - 600 s]	When an End of Curve condition is detected, a timer is activated. When the time set in this parameter expires, and the End of Curve condition has been steady in the entire period, the function set in <i>22-50 End of Curve Function</i> will be activated. If the condition disappears before the timer expires, the timer will be reset.

22-80 Flow Compensation	
Option:	Function:
[0] * Disabled	Set-Point compensation not active.
[1] Enabled	Set-Point compensation is active. Enabling this parameter allows the Flow Compensated Setpoint operation.

22-81 Square-linear Curve Approximation	
Range:	Function:
100 %* [0 - 100 %]	<p>Example 1:</p> <p>Adjustment of this parameter allows the shape of the control curve to be adjusted.</p> <p>0 = Linear</p> <p>100% = Ideal shape (theoretical).</p>

NOTE

Not visible when running in cascade.

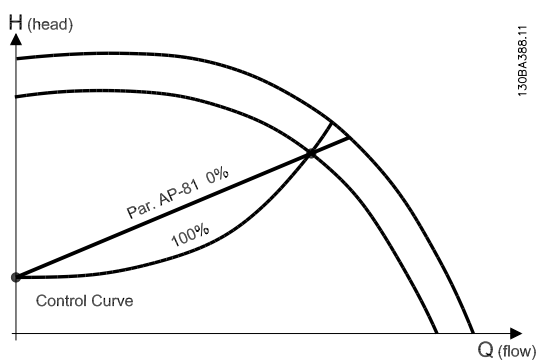

Illustration 6.20

6

22-82 Work Point Calculation

Option:	Function:
[0]	Disabled
[1]	Enabled

Example 1:

Illustration 6.21 Speed at System Design Working Point is Known

From the data sheet showing characteristics for the specific equipment at different speeds, simply reading across from the H_{DESIGN} point and the Q_{DESIGN} point allows us to find point A, which is the System Design Working Point. The pump characteristics at this point should be identified and the associated speed programmed. Closing the valves and adjusting the speed until H_{MIN} has been achieved allows the speed at the no flow point to be identified.

Adjustment of 22-81 *Square-linear Curve Approximation* then allows the shape of the control curve to be adjusted infinitely.

Example 2:

Speed at System Design Working Point is not known: Where the Speed at System Design Working Point is unknown, another reference point on the control curve needs to be determined by means of the data sheet. By looking at the curve for the rated speed and plotting the design pressure (H_{DESIGN} , Point C) the flow at that pressure Q_{RATED} can be determined. Similarly, by plotting the design flow (Q_{DESIGN} , Point D). The pressure H_{DESIGN} at that flow can be determined. Knowing these two points on the pump curve, along with H_{MIN} as described above, allows the frequency converter to calculate the reference point B and

22-82 Work Point Calculation

Option:	Function:
[0]	Disabled
[1]	Enabled

thus to plot the control curve which will also include the System design Working Point A.

Illustration 6.22

22-83 Speed at No-Flow [RPM]

Range:	Function:
Size related* [0 - par. 22-85 RPM]	Resolution 1 RPM. The speed of the motor at which flow is zero and minimum pressure H_{MIN} is achieved should be entered here in RPM. Alternatively, the speed in Hz can be entered in 22-84 <i>Speed at No-Flow [Hz]</i> . If it has been decided to use RPM in 0-02 <i>Motor Speed Unit</i> then 22-85 <i>Speed at Design Point [RPM]</i> should also be used. Closing the valves and reducing the speed until minimum pressure H_{MIN} is achieved will determine this value.

22-84 Speed at No-Flow [Hz]

Range:	Function:
Size related* [0.0 - par. 22-86 Hz]	Resolution 0.033 Hz. The speed of the motor at which flow has effectively stopped and minimum pressure H_{MIN} is achieved should be entered here in Hz. Alternatively, the speed in RPM can be entered in 22-83 <i>Speed at No-Flow [RPM]</i> . If it has been decided to use Hz in 0-02 <i>Motor Speed Unit</i> then 22-86 <i>Speed at Design Point [Hz]</i> should also be used. Closing the valves and reducing the speed until minimum pressure H_{MIN} is achieved will determine this value.



22-85 Speed at Design Point [RPM]		
Range:		Function:
Size related*	[par. 22-83 - 60000. RPM]	Resolution 1 RPM. Only visible when 22-82 <i>Work Point Calculation</i> is set to <i>Disable</i> . The speed of the motor at which the System Design Working Point is achieved should be entered here in RPM. Alternatively, the speed in Hz can be entered in 22-86 <i>Speed at Design Point [Hz]</i> . If it has been decided to use RPM in 0-02 <i>Motor Speed Unit</i> then 22-83 <i>Speed at No-Flow [RPM]</i> should also be used.

22-86 Speed at Design Point [Hz]		
Range:		Function:
Size related*	[par. 22-84 - par. 4-19 Hz]	Resolution 0.033 Hz. Only visible when 22-82 <i>Work Point Calculation</i> is set to <i>Disable</i> . The speed of the motor at which the System Design Working Point is achieved should be entered here in Hz. Alternatively, the speed in RPM can be entered in 22-85 <i>Speed at Design Point [RPM]</i> . If it has been decided to use Hz in 0-02 <i>Motor Speed Unit</i> , then 22-83 <i>Speed at No-Flow [RPM]</i> should also be used.

22-87 Pressure at No-Flow Speed		
Range:		Function:
0.000 *	[0.000 - par. 22-88]	Enter the pressure H _{MIN} corresponding to Speed at No Flow in Reference/Feedback Units.

Also see 22-82 *Work Point Calculation* point D.

22-88 Pressure at Rated Speed		
Range:		Function:
999999.999 *	[par. 22-87 - 999999.999]	Enter the value corresponding to the Pressure at Rated Speed, in Reference/Feedback Units. This value can be defined using the pump datasheet.

Also see 22-82 *Work Point Calculation* point C.

22-90 Flow at Rated Speed		
Range:		Function:
0.000 *	[0.000 - 999999.999]	Enter the value corresponding to Flow at Rated Speed. This value can be defined using the pump datasheet.



6.3.8 T-0#

Use *Timed Actions* for actions needing to be performed on a daily or weekly basis, e.g. different references for working hours/non-working hours. Up to 10 Timed Actions can be programmed in the frequency converter. The Timed Action number is selected from the list when entering parameter group T-0# from the LCP. 23-00 ON Time – 23-04 Occurrence then refer to the selected Timed Action number. Each Timed Action is divided into an ON time and an OFF time, in which two different actions may be performed.

The clock control (parameter group K-7* Clock Settings) of Timed Actions can be overridden from *Timed Actions Auto* (Clock Controlled) to *Timed Actions Disabled*, *Constant OFF Actions* or *Constant ON Actions* either in 23-08 Timed Actions Mode or with commands applied to the digital inputs ([68] Timed Actions Disabled, [69] Constant OFF Actions or [70] Constant ON Actions, in parameter group E-0* Digital Inputs).

Display lines 2 and 3 in the LCP show the status for Timed Actions Mode (0-23 Display Line 2 Large and 0-24 Display Line 3 Large, setting [1243] Timed Actions Status).

NOTE

A change in mode via the digital inputs can only take place if 23-08 Timed Actions Mode is set for [0] Times Actions Auto.

If commands are applied simultaneously to the digital inputs for Constant OFF and Constant ON, the Timed Actions mode will change to Timed Actions Auto and the two commands will be disregarded.

If 0-70 Date and Time is not set or the frequency converter is set to HAND or OFF mode (e.g. via the LCP), the Timed Actions mode will be change to *Timed Actions Disabled*. The Timed Actions have a higher priority than the same actions/commands activated by the digital inputs or the Smart Logic Controller.

NOTE

The clock (parameter group K-7#) must be correctly programmed for Timed Actions to function correctly.

NOTE

When mounting an Analog I/O OPCAIO option card, a battery back up of the date and time is included.

23-00 ON Time	
Array [10]	
Range:	Function:
Size related*	[0 - 0] Sets the ON time for the Timed Action.

23-00 ON Time	
Array [10]	
Range:	Function:
	NOTE The frequency converter has no back up of the clock function and the set date/time will reset to default (2000-01-01 00:00) after a power down unless the Analog I/O option module (OPCAIO) with Battery Back Up of the Real Time Clock is installed. In 0-79 Clock Fault it is possible to program for a Warning in case clock has not been set properly, e.g. after a power down.

23-01 ON Action	
Arra [10]	
Option:	Function:
	Select the action during ON Time. See 13-52 SL Controller Action for descriptions of the options.
[0] *	Disabled
[1]	No action
[2]	Select set-up 1
[3]	Select set-up 2
[4]	Select set-up 3
[5]	Select set-up 4
[10]	Select preset ref 0
[11]	Select preset ref 1
[12]	Select preset ref 2
[13]	Select preset ref 3
[14]	Select preset ref 4
[15]	Select preset ref 5
[16]	Select preset ref 6
[17]	Select preset ref 7
[18]	Select ramp 1
[19]	Select ramp 2
[22]	Run
[23]	Run reverse
[24]	Stop
[26]	DC Brake
[27]	Coast
[28]	Freeze output
[29]	Start timer 0
[30]	Start timer 1
[31]	Start timer 2
[32]	Set digital out A low
[33]	Set digital out B low
[34]	Set digital out C low
[35]	Set digital out D low
[36]	Set digital out E low
[37]	Set digital out F low



23-01 ON Action		
Array [10]		
Option:	Function:	
[38]	Set digital out A high	
[39]	Set digital out B high	
[40]	Set digital out C high	
[41]	Set digital out D high	
[42]	Set digital out E high	
[43]	Set digital out F high	
[60]	Reset Counter A	
[61]	Reset Counter B	
[70]	Start Timer 3	
[71]	Start Timer 4	
[72]	Start Timer 5	
[73]	Start Timer 6	
[74]	Start Timer 7	
[81]	Derag	

23-02 OFF Time		
Array [10]		
Range:	Function:	
Size related*	[0 - 0]	Sets the OFF time for the Timed Action.
<p>NOTE The frequency converter has no back up of the clock function and the set date/time will reset to default (2000-01-01 00:00) after a power down unless the Analog I/O option module (OPCAIO) with Battery Back Up of the Real Time Clock is installed. In 0-79 Clock Fault it is possible to program for a Warning in case clock has not been set properly, e.g. after a power down.</p>		

23-03 OFF Action		
Array [10]		
Option:	Function:	
		Select the action during OFF Time. See 13-52 SL Controller Action for descriptions of the options.
[0] *	Disabled	
[1]	No action	
[2]	Select set-up 1	
[3]	Select set-up 2	
[4]	Select set-up 3	
[5]	Select set-up 4	
[10]	Select preset ref 0	
[11]	Select preset ref 1	
[12]	Select preset ref 2	
[13]	Select preset ref 3	
[14]	Select preset ref 4	
[15]	Select preset ref 5	

23-03 OFF Action		
Array [10]		
Option:	Function:	
[16]	Select preset ref 6	
[17]	Select preset ref 7	
[18]	Select ramp 1	
[19]	Select ramp 2	
[22]	Run	
[23]	Run reverse	
[24]	Stop	
[26]	DC Brake	
[27]	Coast	
[28]	Freeze output	
[29]	Start timer 0	
[30]	Start timer 1	
[31]	Start timer 2	
[32]	Set digital out A low	
[33]	Set digital out B low	
[34]	Set digital out C low	
[35]	Set digital out D low	
[36]	Set digital out E low	
[37]	Set digital out F low	
[38]	Set digital out A high	
[39]	Set digital out B high	
[40]	Set digital out C high	
[41]	Set digital out D high	
[42]	Set digital out E high	
[43]	Set digital out F high	
[60]	Reset Counter A	
[61]	Reset Counter B	
[70]	Start Timer 3	
[71]	Start Timer 4	
[72]	Start Timer 5	
[73]	Start Timer 6	
[74]	Start Timer 7	
[81]	Derag	



6

23-04 Occurrence		
Array [10]		
Option:		Function:
		Select which day(s) the Timed Action applies to. Specify working/non-working days in <i>0-81 Working Days</i> , <i>0-82 Additional Working Days</i> and <i>0-83 Additional Non-Working Days</i> .
[0] *	All days	
[1]	Working days	
[2]	Non-working days	
[3]	Monday	
[4]	Tuesday	
[5]	Wednesday	
[6]	Thursday	
[7]	Friday	
[8]	Saturday	
[9]	Sunday	



6.3.9 29-** Water Application Functions

The group contains parameters used for monitoring water/wastewater applications.

29-00 Pipe Fill Enable		
Option:	Function:	
[0] *	Disabled	Select Enabled to fill pipes at a user specified rate.
[1]	Enabled	Select Enabled to fill pipes with a user specified rate.

29-01 Pipe Fill Speed [RPM]		
Range:	Function:	
Size related*	[par. 4-11 - par. 4-13 RPM]	

29-02 Pipe Fill Speed [Hz]		
Range:	Function:	
Size related*	[par. 4-12 - par. 4-14 Hz]	

29-03 Pipe Fill Time		
Range:	Function:	
0.00 s*	[0.00 - 3600.00 s]	Set the specified time for pipe filling of horizontal pipe systems.

29-04 Pipe Fill Rate		
Range:	Function:	
0.001 ProcessCtrlUnit*	[0.001 - 999999.999 ProcessCtrlUnit]	Specifies the filling rate in units/second using the PI controller. Filling rate units are feedback units/second. This function is used for filling-up vertical pipe systems but will always be active when the filling-time has expired, until the pipe fill-set-point set in 29-05 Filled Setpoint is reached.

29-05 Filled Setpoint		
Range:	Function:	
0.000 ProcessCtrlUnit*	[-999999.999 - 999999.999 ProcessCtrlUnit]	Specifies the Filled Setpoint at which the Pipe Fill Function will be disabled and the PID controller will take control. This function can be used both for horizontal and vertical pipe systems.



6.4 Parameter Options

6.4.1 Default settings

Changes during operation:

"TRUE" means that the parameter can be changed while the frequency converter is in operation and "FALSE" means that the frequency converter must be stopped before a change can be made.

4-Set-up:

'All set-up': the parameter can be set individually in each of the four set-ups, i. e. one single parameter can have four different data values.

'1 set-up': data value will be the same in all set-ups.

SR:

Size related

N/A:

No default value available.

Conversion index:

This number refers to a conversion figure used when writing or reading by means of a frequency converter.

6

Conv. index	100	75	74	70	67	6	5	4	3	2	1	0	-1	-2	-3	-4	-5	-6
Conv. factor	1	3600000	3600	60	1/60	100000 0	10000 0	10000	1000	100	10	1	0.1	0.01	0.001	0.000 1	0.00001	0.00000 1

Table 6.18

Data type	Description	Type
2	Integer 8	Int8
3	Integer 16	Int16
4	Integer 32	Int32
5	Unsigned 8	UInt8
6	Unsigned 16	UInt16
7	Unsigned 32	UInt32
9	Visible String	VisStr
33	Normalized value 2 bytes	N2
35	Bit sequence of 16 boolean variables	V2
54	Time difference w/o date	TimD

Table 6.19



6.4.2 0-** Operation/Display

Par. No. #	Parameter description	Default value	4-set-up	Change during operation	Conversion index	Type
0-0* Basic Settings						
0-01	Language	[0] English	1 set-up	TRUE	-	UInt8
0-02	Motor Speed Unit	[0] RPM	2 set-ups	FALSE	-	UInt8
0-03	Regional Settings	[0] International	2 set-ups	FALSE	-	UInt8
0-04	Operating State at Power-up	[0] Resume	All set-ups	TRUE	-	UInt8
0-05	Local Mode Unit	[0] As Motor Speed Unit	2 set-ups	FALSE	-	UInt8
0-1* Set-up Operations						
0-10	Active Set-up	[1] Set-up 1	1 set-up	TRUE	-	UInt8
0-11	Programming Set-up	[9] Active Set-up	All set-ups	TRUE	-	UInt8
0-12	This Set-up Linked to	[0] Not linked	All set-ups	FALSE	-	UInt8
0-13	Readout: Linked Set-ups	0 N/A	All set-ups	FALSE	0	UInt16
0-14	Readout: Prog. Set-ups / Channel	0 N/A	All set-ups	TRUE	0	Int32
0-2* LCP Display						
0-20	Display Line 1.1 Small	1601	All set-ups	TRUE	-	UInt16
0-21	Display Line 1.2 Small	1662	All set-ups	TRUE	-	UInt16
0-22	Display Line 1.3 Small	1614	All set-ups	TRUE	-	UInt16
0-23	Display Line 2 Large	1613	All set-ups	TRUE	-	UInt16
0-24	Display Line 3 Large	1652	All set-ups	TRUE	-	UInt16
0-25	My Personal Menu	ExpressionLimit	1 set-up	TRUE	0	UInt16
0-3* LCP Custom Readout						
0-30	Custom Readout Unit	[1] %	All set-ups	TRUE	-	UInt8
0-31	Custom Readout Min Value	ExpressionLimit	All set-ups	TRUE	-2	Int32
0-32	Custom Readout Max Value	100.00 CustomReadoutUnit	All set-ups	TRUE	-2	Int32
0-37	Display Text 1	0 N/A	1 set-up	TRUE	0	VisStr[25]
0-38	Display Text 2	0 N/A	1 set-up	TRUE	0	VisStr[25]
0-39	Display Text 3	0 N/A	1 set-up	TRUE	0	VisStr[25]
0-4* LCP Keypad						
0-40	[Hand on] Key on LCP	[1] Enabled	All set-ups	TRUE	-	UInt8
0-41	[Off] Key on LCP	[1] Enabled	All set-ups	TRUE	-	UInt8
0-42	[Auto on] Key on LCP	[1] Enabled	All set-ups	TRUE	-	UInt8
0-43	[Reset] Key on LCP	[1] Enabled	All set-ups	TRUE	-	UInt8
0-44	[Off/Reset] Key on LCP	[1] Enabled	All set-ups	TRUE	-	UInt8
0-45	[Drive Bypass] Key on LCP	[1] Enabled	All set-ups	TRUE	-	UInt8
0-5* Copy/Save						
0-50	LCP Copy	[0] No copy	All set-ups	FALSE	-	UInt8
0-51	Set-up Copy	[0] No copy	All set-ups	FALSE	-	UInt8
0-6* Password						
0-60	Main Menu Password	100 N/A	1 set-up	TRUE	0	Int16
0-61	Access to Main Menu w/o Password	[0] Full access	1 set-up	TRUE	-	UInt8
0-65	Personal Menu Password	200 N/A	1 set-up	TRUE	0	UInt16
0-66	Access to Personal Menu w/o Password	[0] Full access	1 set-up	TRUE	-	UInt8
0-67	Bus Password Access	0 N/A	All set-ups	TRUE	0	UInt16
0-7* Clock Settings						
0-70	Date and Time	ExpressionLimit	All set-ups	TRUE	0	TimeOfDay
0-71	Date Format	[0] YYYY-MM-DD	1 set-up	TRUE	-	UInt8
0-72	Time Format	[0] 24 h	1 set-up	TRUE	-	UInt8
0-74	DST/Summertime	[0] Off	1 set-up	TRUE	-	UInt8
0-76	DST/Summertime Start	ExpressionLimit	1 set-up	TRUE	0	TimeOfDay



Par. No. #	Parameter description	Default value	4-set-up	Change during operation	Conver- sion index	Type
0-77	DST/Summertime End	ExpressionLimit	1 set-up	TRUE	0	TimeOfDay
0-79	Clock Fault	null	1 set-up	TRUE	-	Uint8
0-81	Working Days	null	1 set-up	TRUE	-	Uint8
0-82	Additional Working Days	ExpressionLimit	1 set-up	TRUE	0	TimeOfDay
0-83	Additional Non-Working Days	ExpressionLimit	1 set-up	TRUE	0	TimeOfDay
0-89	Date and Time Readout	0 N/A	All set-ups	TRUE	0	VisStr[25]

Table 6.20



6.4.3 1-** Load/Motor

Par. No. #	Parameter description	Default value	4-set-up	Change during operation	Conversion index	Type
1-0* General Settings						
1-00	Configuration Mode	null	All set-ups	TRUE	-	Uint8
1-01	Motor Control Principle	null	All set-ups	FALSE	-	Uint8
1-03	Torque Characteristics	[3] Auto Energy Optim. VT	All set-ups	TRUE	-	Uint8
1-06	Clockwise Direction	[0] Normal	All set-ups	FALSE	-	Uint8
1-1* Motor Selection						
1-10	Motor Construction	[0] Asynchron	All set-ups	FALSE	-	Uint8
1-2* Motor Data						
1-20	Motor Power [kW]	ExpressionLimit	All set-ups	FALSE	1	Uint32
1-21	Motor Power [HP]	ExpressionLimit	All set-ups	FALSE	-2	Uint32
1-22	Motor Voltage	ExpressionLimit	All set-ups	FALSE	0	Uint16
1-23	Motor Frequency	ExpressionLimit	All set-ups	FALSE	0	Uint16
1-24	Motor Current	ExpressionLimit	All set-ups	FALSE	-2	Uint32
1-25	Motor Nominal Speed	ExpressionLimit	All set-ups	FALSE	67	Uint16
1-28	Motor Rotation Check	[0] Off	All set-ups	FALSE	-	Uint8
1-29	Automatic Motor Adaptation (AMA)	[0] Off	All set-ups	FALSE	-	Uint8
1-3* Adv. Motor Data						
1-30	Stator Resistance (Rs)	ExpressionLimit	All set-ups	FALSE	-4	Uint32
1-31	Rotor Resistance (Rr)	ExpressionLimit	All set-ups	FALSE	-4	Uint32
1-33	Stator Leakage Reactance (X1)	ExpressionLimit	All set-ups	FALSE	-4	Uint32
1-34	Rotor Leakage Reactance (X2)	ExpressionLimit	All set-ups	FALSE	-4	Uint32
1-35	Main Reactance (Xh)	ExpressionLimit	All set-ups	FALSE	-4	Uint32
1-36	Iron Loss Resistance (Rfe)	ExpressionLimit	All set-ups	FALSE	-3	Uint32
1-39	Motor Poles	ExpressionLimit	All set-ups	FALSE	0	Uint8
1-5* Load Indep. Setting						
1-50	Motor Magnetisation at Zero Speed	100 %	All set-ups	TRUE	0	Uint16
1-51	Min Speed Normal Magnetising [RPM]	ExpressionLimit	All set-ups	TRUE	67	Uint16
1-52	Min Speed Normal Magnetising [Hz]	ExpressionLimit	All set-ups	TRUE	-1	Uint16
1-55	V/f Characteristic - V	ExpressionLimit	All set-ups	TRUE	-1	Uint16
1-56	V/f Characteristic - f	ExpressionLimit	All set-ups	TRUE	-1	Uint16
1-58	Flystart Test Pulses Current	30 %	All set-ups	FALSE	0	Uint16
1-59	Flystart Test Pulses Frequency	200 %	All set-ups	FALSE	0	Uint16
1-6* Load Depen. Setting						
1-60	Low Speed Load Compensation	100 %	All set-ups	TRUE	0	Int16
1-61	High Speed Load Compensation	100 %	All set-ups	TRUE	0	Int16
1-62	Slip Compensation	0 %	All set-ups	TRUE	0	Int16
1-63	Slip Compensation Time Constant	ExpressionLimit	All set-ups	TRUE	-2	Uint16
1-64	Resonance Dampening	100 %	All set-ups	TRUE	0	Uint16
1-65	Resonance Dampening Time Constant	5 ms	All set-ups	TRUE	-3	Uint8
1-7* Start Adjustments						
1-71	Start Delay	0.0 s	All set-ups	TRUE	-1	Uint16
1-72	Start Function	null	All set-ups	TRUE	-	Uint8
1-73	Flying Start	[0] Disabled	All set-ups	FALSE	-	Uint8
1-74	Start Speed [RPM]	ExpressionLimit	All set-ups	TRUE	67	Uint16
1-75	Start Speed [Hz]	ExpressionLimit	All set-ups	TRUE	-1	Uint16
1-76	Start Current	0.00 A	All set-ups	TRUE	-2	Uint32
1-8* Stop Adjustments						
1-80	Function at Stop	[0] Coast	All set-ups	TRUE	-	Uint8
1-81	Min Speed for Function at Stop [RPM]	ExpressionLimit	All set-ups	TRUE	67	Uint16



Par. No. #	Parameter description	Default value	4-set-up	Change during operation	Conver- sion index	Type
1-82	Min Speed for Function at Stop [Hz]	ExpressionLimit	All set-ups	TRUE	-1	Uint16
1-86	Trip Speed Low [RPM]	0 RPM	All set-ups	TRUE	67	Uint16
1-87	Trip Speed Low [Hz]	0 Hz	All set-ups	TRUE	-1	Uint16
1-9* Motor Temperature						
1-90	Motor Thermal Protection	[4] ETR trip 1	All set-ups	TRUE	-	Uint8
1-91	Motor External Fan	[0] No	All set-ups	TRUE	-	Uint16
1-93	Thermistor Source	[0] None	All set-ups	TRUE	-	Uint8

Table 6.21



6.4.4 2-** Brakes

Par. No. #	Parameter description	Default value	4-set-up	Change during operation	Conver- sion index	Type
2-0* DC-Brake						
2-00	DC Hold/Preheat Current	50 %	All set-ups	TRUE	0	Uint8
2-01	DC Brake Current	50 %	All set-ups	TRUE	0	Uint16
2-02	DC Braking Time	10.0 s	All set-ups	TRUE	-1	Uint16
2-03	DC Brake Cut In Speed [RPM]	ExpressionLimit	All set-ups	TRUE	67	Uint16
2-04	DC Brake Cut In Speed [Hz]	ExpressionLimit	All set-ups	TRUE	-1	Uint16
2-1* Brake Energy Funct.						
2-10	Brake Function	[0] Off	All set-ups	TRUE	-	Uint8
2-11	Brake Resistor (ohm)	ExpressionLimit	All set-ups	TRUE	0	Uint16
2-12	Brake Power Limit (kW)	ExpressionLimit	All set-ups	TRUE	0	Uint32
2-13	Brake Power Monitoring	[0] Off	All set-ups	TRUE	-	Uint8
2-15	Brake Check	[0] Off	All set-ups	TRUE	-	Uint8
2-16	AC brake Max. Current	100.0 %	All set-ups	TRUE	-1	Uint32
2-17	Over-voltage Control	[2] Enabled	All set-ups	TRUE	-	Uint8

Table 6.22



6.4.5 3-** Reference/Ramps

6

Par. No. #	Parameter description	Default value	4-set-up	Change during operation	Conversion index	Type
3-0* Reference Limits						
3-02	Minimum Reference	ExpressionLimit	All set-ups	TRUE	-3	Int32
3-03	Maximum Reference	ExpressionLimit	All set-ups	TRUE	-3	Int32
3-04	Reference Function	[0] Sum	All set-ups	TRUE	-	Uint8
3-1* References						
3-10	Preset Reference	0.00 %	All set-ups	TRUE	-2	Int16
3-11	Jog Speed [Hz]	ExpressionLimit	All set-ups	TRUE	-1	Uint16
3-13	Reference Site	[0] Linked to Hand / Auto	All set-ups	TRUE	-	Uint8
3-14	Preset Relative Reference	0.00 %	All set-ups	TRUE	-2	Int32
3-15	Reference 1 Source	[1] Analog input 53	All set-ups	TRUE	-	Uint8
3-16	Reference 2 Source	[0] No function	All set-ups	TRUE	-	Uint8
3-17	Reference 3 Source	[0] No function	All set-ups	TRUE	-	Uint8
3-19	Jog Speed [RPM]	ExpressionLimit	All set-ups	TRUE	67	Uint16
3-4* Ramp 1						
3-41	Ramp 1 Ramp Up Time	ExpressionLimit	All set-ups	TRUE	-2	Uint32
3-42	Ramp 1 Ramp Down Time	ExpressionLimit	All set-ups	TRUE	-2	Uint32
3-5* Ramp 2						
3-51	Ramp 2 Ramp Up Time	ExpressionLimit	All set-ups	TRUE	-2	Uint32
3-52	Ramp 2 Ramp Down Time	ExpressionLimit	All set-ups	TRUE	-2	Uint32
3-8* Other Ramps						
3-80	Jog Ramp Time	ExpressionLimit	All set-ups	TRUE	-2	Uint32
3-81	Quick Stop Ramp Time	ExpressionLimit	2 set-ups	TRUE	-2	Uint32
3-84	Initial Ramp Time	0.00 s	All set-ups	TRUE	-2	Uint16
3-85	Check Valve Ramp Time	0.00 s	All set-ups	TRUE	-2	Uint16
3-86	Check Valve Ramp End Speed [RPM]	ExpressionLimit	All set-ups	TRUE	67	Uint16
3-87	Check Valve Ramp End Speed [HZ]	ExpressionLimit	All set-ups	TRUE	-1	Uint16
3-88	Final Ramp Time	0.00 s	All set-ups	TRUE	-2	Uint16
3-9* Digital Pot.Meter						
3-90	Step Size	0.10 %	All set-ups	TRUE	-2	Uint16
3-91	Ramp Time	1.00 s	All set-ups	TRUE	-2	Uint32
3-92	Power Restore	[0] Off	All set-ups	TRUE	-	Uint8
3-93	Maximum Limit	100 %	All set-ups	TRUE	0	Int16
3-94	Minimum Limit	0 %	All set-ups	TRUE	0	Int16
3-95	Ramp Delay	ExpressionLimit	All set-ups	TRUE	-3	TimD

Table 6.23



6.4.6 4-** Limits/Warnings

Par. No. #	Parameter description	Default value	4-set-up	Change during operation	Conversion index	Type
4-1* Motor Limits						
4-10	Motor Speed Direction	[0] Clockwise	All set-ups	FALSE	-	Uint8
4-11	Motor Speed Low Limit [RPM]	ExpressionLimit	All set-ups	TRUE	67	Uint16
4-12	Motor Speed Low Limit [Hz]	ExpressionLimit	All set-ups	TRUE	-1	Uint16
4-13	Motor Speed High Limit [RPM]	ExpressionLimit	All set-ups	TRUE	67	Uint16
4-14	Motor Speed High Limit [Hz]	ExpressionLimit	All set-ups	TRUE	-1	Uint16
4-16	Torque Limit Motor Mode	ExpressionLimit	All set-ups	TRUE	-1	Uint16
4-17	Torque Limit Generator Mode	100.0 %	All set-ups	TRUE	-1	Uint16
4-18	Current Limit	ExpressionLimit	All set-ups	TRUE	-1	Uint32
4-19	Max Output Frequency	ExpressionLimit	All set-ups	FALSE	-1	Uint16
4-5* Adj. Warnings						
4-50	Warning Current Low	0.00 A	All set-ups	TRUE	-2	Uint32
4-51	Warning Current High	ImaxVLT (P1637)	All set-ups	TRUE	-2	Uint32
4-52	Warning Speed Low	0 RPM	All set-ups	TRUE	67	Uint16
4-53	Warning Speed High	outputSpeedHighLimit (P413)	All set-ups	TRUE	67	Uint16
4-54	Warning Reference Low	-999999.999 N/A	All set-ups	TRUE	-3	Int32
4-55	Warning Reference High	999999.999 N/A	All set-ups	TRUE	-3	Int32
4-56	Warning Feedback Low	-999999.999 Reference-FeedbackUnit	All set-ups	TRUE	-3	Int32
4-57	Warning Feedback High	999999.999 Reference-FeedbackUnit	All set-ups	TRUE	-3	Int32
4-58	Missing Motor Phase Function	[2] Trip 1000 ms	All set-ups	TRUE	-	Uint8
4-6* Speed Bypass						
4-60	Bypass Speed From [RPM]	ExpressionLimit	All set-ups	TRUE	67	Uint16
4-61	Bypass Speed From [Hz]	ExpressionLimit	All set-ups	TRUE	-1	Uint16
4-62	Bypass Speed To [RPM]	ExpressionLimit	All set-ups	TRUE	67	Uint16
4-63	Bypass Speed To [Hz]	ExpressionLimit	All set-ups	TRUE	-1	Uint16
4-64	Semi-Auto Bypass Set-up	[0] Off	All set-ups	FALSE	-	Uint8

Table 6.24



6.4.7 5-** Digital In/Out

6

Par. No. #	Parameter description	Default value	4-set-up	Change during operation	Conversion index	Type
5-0* Digital I/O mode						
5-00	Digital I/O Mode	[0] PNP - Active at 24V	All set-ups	FALSE	-	Uint8
5-01	Terminal 27 Mode	[0] Input	All set-ups	TRUE	-	Uint8
5-02	Terminal 29 Mode	[0] Input	All set-ups	TRUE	-	Uint8
5-1* Digital Inputs						
5-10	Terminal 18 Digital Input	[8] Start	All set-ups	TRUE	-	Uint8
5-11	Terminal 19 Digital Input	[0] No operation	All set-ups	TRUE	-	Uint8
5-12	Terminal 27 Digital Input	null	All set-ups	TRUE	-	Uint8
5-13	Terminal 29 Digital Input	[0] No operation	All set-ups	TRUE	-	Uint8
5-14	Terminal 32 Digital Input	[0] No operation	All set-ups	TRUE	-	Uint8
5-15	Terminal 33 Digital Input	[0] No operation	All set-ups	TRUE	-	Uint8
5-16	Terminal X30/2 Digital Input	[0] No operation	All set-ups	TRUE	-	Uint8
5-17	Terminal X30/3 Digital Input	[0] No operation	All set-ups	TRUE	-	Uint8
5-18	Terminal X30/4 Digital Input	[0] No operation	All set-ups	TRUE	-	Uint8
5-19	Terminal 37 Digital Input	[1] Safe Stop Alarm	1 set-up	TRUE	-	Uint8
5-3* Digital Outputs						
5-30	Terminal 27 Digital Output	[0] No operation	All set-ups	TRUE	-	Uint8
5-31	Terminal 29 Digital Output	[0] No operation	All set-ups	TRUE	-	Uint8
5-32	Term X30/6 Digi Out (MCB 101)	[0] No operation	All set-ups	TRUE	-	Uint8
5-33	Term X30/7 Digi Out (MCB 101)	[0] No operation	All set-ups	TRUE	-	Uint8
5-4* Relays						
5-40	Function Relay	null	All set-ups	TRUE	-	Uint8
5-41	On Delay, Relay	0.01 s	All set-ups	TRUE	-2	Uint16
5-42	Off Delay, Relay	0.01 s	All set-ups	TRUE	-2	Uint16
5-5* Pulse Input						
5-50	Term. 29 Low Frequency	100 Hz	All set-ups	TRUE	0	Uint32
5-51	Term. 29 High Frequency	100 Hz	All set-ups	TRUE	0	Uint32
5-52	Term. 29 Low Ref./Feedb. Value	0.000 N/A	All set-ups	TRUE	-3	Int32
5-53	Term. 29 High Ref./Feedb. Value	100.000 N/A	All set-ups	TRUE	-3	Int32
5-54	Pulse Filter Time Constant #29	100 ms	All set-ups	FALSE	-3	Uint16
5-55	Term. 33 Low Frequency	100 Hz	All set-ups	TRUE	0	Uint32
5-56	Term. 33 High Frequency	100 Hz	All set-ups	TRUE	0	Uint32
5-57	Term. 33 Low Ref./Feedb. Value	0.000 N/A	All set-ups	TRUE	-3	Int32
5-58	Term. 33 High Ref./Feedb. Value	100.000 N/A	All set-ups	TRUE	-3	Int32
5-59	Pulse Filter Time Constant #33	100 ms	All set-ups	FALSE	-3	Uint16
5-6* Pulse Output						
5-60	Terminal 27 Pulse Output Variable	[0] No operation	All set-ups	TRUE	-	Uint8
5-62	Pulse Output Max Freq #27	5000 Hz	All set-ups	TRUE	0	Uint32
5-63	Terminal 29 Pulse Output Variable	[0] No operation	All set-ups	TRUE	-	Uint8
5-65	Pulse Output Max Freq #29	5000 Hz	All set-ups	TRUE	0	Uint32
5-66	Terminal X30/6 Pulse Output Variable	[0] No operation	All set-ups	TRUE	-	Uint8
5-68	Pulse Output Max Freq #X30/6	5000 Hz	All set-ups	TRUE	0	Uint32
5-8* I/O Options						
5-80	AHF Cap Reconnect Delay	25 s	2 set-ups	TRUE	0	Uint16
5-9* Bus Controlled						
5-90	Digital & Relay Bus Control	0 N/A	All set-ups	TRUE	0	Uint32
5-93	Pulse Out #27 Bus Control	0.00 %	All set-ups	TRUE	-2	N2
5-94	Pulse Out #27 Timeout Preset	0.00 %	1 set-up	TRUE	-2	Uint16
5-95	Pulse Out #29 Bus Control	0.00 %	All set-ups	TRUE	-2	N2



Par. No. #	Parameter description	Default value	4-set-up	Change during operation	Conversion index	Type
5-96	Pulse Out #29 Timeout Preset	0.00 %	1 set-up	TRUE	-2	Uint16
5-97	Pulse Out #X30/6 Bus Control	0.00 %	All set-ups	TRUE	-2	N2
5-98	Pulse Out #X30/6 Timeout Preset	0.00 %	1 set-up	TRUE	-2	Uint16

Table 6.25



6.4.8 6-** Analog In/Out

6

Par. No. #	Parameter description	Default value	4-set-up	Change during operation	Conversion index	Type
6-0* Analog I/O Mode						
6-00	Live Zero Timeout Time	10 s	All set-ups	TRUE	0	UInt8
6-01	Live Zero Timeout Function	[0] Off	All set-ups	TRUE	-	UInt8
6-1* Analog Input 53						
6-10	Terminal 53 Low Voltage	0.07 V	All set-ups	TRUE	-2	Int16
6-11	Terminal 53 High Voltage	10.00 V	All set-ups	TRUE	-2	Int16
6-12	Terminal 53 Low Current	4.00 mA	All set-ups	TRUE	-5	Int16
6-13	Terminal 53 High Current	20.00 mA	All set-ups	TRUE	-5	Int16
6-14	Terminal 53 Low Ref./Feedb. Value	0.000 N/A	All set-ups	TRUE	-3	Int32
6-15	Terminal 53 High Ref./Feedb. Value	ExpressionLimit	All set-ups	TRUE	-3	Int32
6-16	Terminal 53 Filter Time Constant	0.001 s	All set-ups	TRUE	-3	UInt16
6-17	Terminal 53 Live Zero	[1] Enabled	All set-ups	TRUE	-	UInt8
6-2* Analog Input 54						
6-20	Terminal 54 Low Voltage	0.07 V	All set-ups	TRUE	-2	Int16
6-21	Terminal 54 High Voltage	10.00 V	All set-ups	TRUE	-2	Int16
6-22	Terminal 54 Low Current	4.00 mA	All set-ups	TRUE	-5	Int16
6-23	Terminal 54 High Current	20.00 mA	All set-ups	TRUE	-5	Int16
6-24	Terminal 54 Low Ref./Feedb. Value	0.000 N/A	All set-ups	TRUE	-3	Int32
6-25	Terminal 54 High Ref./Feedb. Value	100.000 N/A	All set-ups	TRUE	-3	Int32
6-26	Terminal 54 Filter Time Constant	0.001 s	All set-ups	TRUE	-3	UInt16
6-27	Terminal 54 Live Zero	[1] Enabled	All set-ups	TRUE	-	UInt8
6-3* Analog Input X30/11						
6-30	Terminal X30/11 Low Voltage	0.07 V	All set-ups	TRUE	-2	Int16
6-31	Terminal X30/11 High Voltage	10.00 V	All set-ups	TRUE	-2	Int16
6-34	Term. X30/11 Low Ref./Feedb. Value	0.000 N/A	All set-ups	TRUE	-3	Int32
6-35	Term. X30/11 High Ref./Feedb. Value	100.000 N/A	All set-ups	TRUE	-3	Int32
6-36	Term. X30/11 Filter Time Constant	0.001 s	All set-ups	TRUE	-3	UInt16
6-37	Term. X30/11 Live Zero	[1] Enabled	All set-ups	TRUE	-	UInt8
6-4* Analog Input X30/12						
6-40	Terminal X30/12 Low Voltage	0.07 V	All set-ups	TRUE	-2	Int16
6-41	Terminal X30/12 High Voltage	10.00 V	All set-ups	TRUE	-2	Int16
6-44	Term. X30/12 Low Ref./Feedb. Value	0.000 N/A	All set-ups	TRUE	-3	Int32
6-45	Term. X30/12 High Ref./Feedb. Value	100.000 N/A	All set-ups	TRUE	-3	Int32
6-46	Term. X30/12 Filter Time Constant	0.001 s	All set-ups	TRUE	-3	UInt16
6-47	Term. X30/12 Live Zero	[1] Enabled	All set-ups	TRUE	-	UInt8
6-5* Analog Output 42						
6-50	Terminal 42 Output	[100] Output freq. 0-100	All set-ups	TRUE	-	UInt8
6-51	Terminal 42 Output Min Scale	0.00 %	All set-ups	TRUE	-2	Int16
6-52	Terminal 42 Output Max Scale	100.00 %	All set-ups	TRUE	-2	Int16
6-53	Terminal 42 Output Bus Control	0.00 %	All set-ups	TRUE	-2	N2
6-54	Terminal 42 Output Timeout Preset	0.00 %	1 set-up	TRUE	-2	UInt16
6-55	Terminal 42 Output Filter	[0] Off	1 set-up	TRUE	-	UInt8
6-6* Analog Output X30/8						
6-60	Terminal X30/8 Output	[0] No operation	All set-ups	TRUE	-	UInt8
6-61	Terminal X30/8 Min. Scale	0.00 %	All set-ups	TRUE	-2	Int16
6-62	Terminal X30/8 Max. Scale	100.00 %	All set-ups	TRUE	-2	Int16
6-63	Terminal X30/8 Output Bus Control	0.00 %	All set-ups	TRUE	-2	N2



How to Programme the Low Ha...

VLT® Automation VT Drive FC 322 Drive LHD for AAF006 Operating Instructions

6-64	Terminal X30/8 Output Timeout Preset	0.00 %	1 set-up	TRUE	-2	Uint16
------	--------------------------------------	--------	----------	------	----	--------

Table 6.26



6.4.9 8-** Comm. and Options

6

Par. No. #	Parameter description	Default value	4-set-up	Change during operation	Conversion index	Type
8-0* General Settings						
8-01	Control Site	null	All set-ups	TRUE	-	UInt8
8-02	Control Source	null	All set-ups	TRUE	-	UInt8
8-03	Control Timeout Time	ExpressionLimit	1 set-up	TRUE	-1	UInt32
8-04	Control Timeout Function	[0] Off	1 set-up	TRUE	-	UInt8
8-05	End-of-Timeout Function	[1] Resume set-up	1 set-up	TRUE	-	UInt8
8-06	Reset Control Timeout	[0] Do not reset	All set-ups	TRUE	-	UInt8
8-07	Diagnosis Trigger	[0] Disable	2 set-ups	TRUE	-	UInt8
8-08	Readout Filtering	null	All set-ups	TRUE	-	UInt8
8-1* Control Settings						
8-10	Control Profile	[0] FC profile	All set-ups	TRUE	-	UInt8
8-13	Configurable Status Word STW	[1] Profile Default	All set-ups	TRUE	-	UInt8
8-14	Configurable Control Word CTW	[1] Profile default	All set-ups	TRUE	-	UInt8
8-3* FC Port Settings						
8-30	Protocol	[0] FC	1 set-up	TRUE	-	UInt8
8-31	Address	ExpressionLimit	1 set-up	TRUE	0	UInt8
8-32	Baud Rate	null	1 set-up	TRUE	-	UInt8
8-33	Parity / Stop Bits	null	1 set-up	TRUE	-	UInt8
8-35	Minimum Response Delay	ExpressionLimit	1 set-up	TRUE	-3	UInt16
8-36	Max Response Delay	ExpressionLimit	1 set-up	TRUE	-3	UInt16
8-37	Maximum Inter-Char Delay	ExpressionLimit	1 set-up	TRUE	-5	UInt16
8-4* FC MC protocol set						
8-40	Telegram Selection	[1] Standard telegram 1	2 set-ups	TRUE	-	UInt8
8-42	PCD Write Configuration	ExpressionLimit	2 set-ups	TRUE	-	UInt16
8-43	PCD Read Configuration	ExpressionLimit	2 set-ups	TRUE	-	UInt16
8-5* Digital/Bus						
8-50	Coasting Select	[3] Logic OR	All set-ups	TRUE	-	UInt8
8-52	DC Brake Select	[3] Logic OR	All set-ups	TRUE	-	UInt8
8-53	Start Select	[3] Logic OR	All set-ups	TRUE	-	UInt8
8-54	Reversing Select	null	All set-ups	TRUE	-	UInt8
8-55	Set-up Select	[3] Logic OR	All set-ups	TRUE	-	UInt8
8-56	Preset Reference Select	[3] Logic OR	All set-ups	TRUE	-	UInt8
8-7* BACnet						
8-70	BACnet Device Instance	1 N/A	1 set-up	TRUE	0	UInt32
8-72	MS/TP Max Masters	127 N/A	1 set-up	TRUE	0	UInt8
8-73	MS/TP Max Info Frames	1 N/A	1 set-up	TRUE	0	UInt16
8-74	"I-Am" Service	[0] Send at power-up	1 set-up	TRUE	-	UInt8
8-75	Initialisation Password	ExpressionLimit	1 set-up	TRUE	0	VisStr[20]
8-8* FC Port Diagnostics						
8-80	Bus Message Count	0 N/A	All set-ups	TRUE	0	UInt32
8-81	Bus Error Count	0 N/A	All set-ups	TRUE	0	UInt32
8-82	Slave Message Rcvd	0 N/A	All set-ups	TRUE	0	UInt32
8-83	Slave Error Count	0 N/A	All set-ups	TRUE	0	UInt32

Table 6.27



Par. No. #	Parameter description	Default value	4-set-up	Change during operation	Conversion index	Type
8-9* Bus Jog / Feedback						
8-90	Bus Jog 1 Speed	100 RPM	All set-ups	TRUE	67	Uint16
8-91	Bus Jog 2 Speed	200 RPM	All set-ups	TRUE	67	Uint16
8-94	Bus Feedback 1	0 N/A	1 set-up	TRUE	0	N2
8-95	Bus Feedback 2	0 N/A	1 set-up	TRUE	0	N2
8-96	Bus Feedback 3	0 N/A	1 set-up	TRUE	0	N2

Table 6.28

6.4.10 9-** Profibus

Par. No. #	Parameter description	Default value	4-set-up	Change during operation	Conversion index	Type
9-00	Setpoint	0 N/A	All set-ups	TRUE	0	Uint16
9-07	Actual Value	0 N/A	All set-ups	FALSE	0	Uint16
9-15	PCD Write Configuration	ExpressionLimit	1 set-up	TRUE	-	Uint16
9-16	PCD Read Configuration	ExpressionLimit	2 set-ups	TRUE	-	Uint16
9-18	Node Address	126 N/A	1 set-up	TRUE	0	Uint8
9-22	Telegram Selection	[100] None	1 set-up	TRUE	-	Uint8
9-23	Parameters for Signals	0	All set-ups	TRUE	-	Uint16
9-27	Parameter Edit	[1] Enabled	2 set-ups	FALSE	-	Uint16
9-28	Process Control	[1] Enable cyclic master	2 set-ups	FALSE	-	Uint8
9-31	Safe Address	0 N/A	1 set-up	TRUE	0	Uint16
9-44	Fault Message Counter	0 N/A	All set-ups	TRUE	0	Uint16
9-45	Fault Code	0 N/A	All set-ups	TRUE	0	Uint16
9-47	Fault Number	0 N/A	All set-ups	TRUE	0	Uint16
9-52	Fault Situation Counter	0 N/A	All set-ups	TRUE	0	Uint16
9-53	Profibus Warning Word	0 N/A	All set-ups	TRUE	0	V2
9-63	Actual Baud Rate	[255] No baudrate found	All set-ups	TRUE	-	Uint8
9-64	Device Identification	0 N/A	All set-ups	TRUE	0	Uint16
9-65	Profile Number	0 N/A	All set-ups	TRUE	0	OctStr[2]
9-67	Control Word 1	0 N/A	All set-ups	FALSE	0	V2
9-68	Status Word 1	0 N/A	All set-ups	TRUE	0	V2
9-71	Profibus Save Data Values	[0] Off	All set-ups	TRUE	-	Uint8
9-72	ProfibusDriveReset	[0] No action	1 set-up	FALSE	-	Uint8
9-75	DO Identification	0 N/A	All set-ups	TRUE	0	Uint16
9-80	Defined Parameters (1)	0 N/A	All set-ups	FALSE	0	Uint16
9-81	Defined Parameters (2)	0 N/A	All set-ups	FALSE	0	Uint16
9-82	Defined Parameters (3)	0 N/A	All set-ups	FALSE	0	Uint16
9-83	Defined Parameters (4)	0 N/A	All set-ups	FALSE	0	Uint16
9-84	Defined Parameters (5)	0 N/A	All set-ups	FALSE	0	Uint16
9-90	Changed Parameters (1)	0 N/A	All set-ups	FALSE	0	Uint16
9-91	Changed Parameters (2)	0 N/A	All set-ups	FALSE	0	Uint16
9-92	Changed Parameters (3)	0 N/A	All set-ups	FALSE	0	Uint16
9-93	Changed Parameters (4)	0 N/A	All set-ups	FALSE	0	Uint16
9-94	Changed Parameters (5)	0 N/A	All set-ups	FALSE	0	Uint16
9-99	Profibus Revision Counter	0 N/A	All set-ups	TRUE	0	Uint16

Table 6.29



6.4.11 10-** CAN Fieldbus

6

Par. No. #	Parameter description	Default value	4-set-up	Change during operation	Conversion index	Type
10-0* Common Settings						
10-00	CAN Protocol	null	2 set-ups	FALSE	-	Uint8
10-01	Baud Rate Select	null	2 set-ups	TRUE	-	Uint8
10-02	MAC ID	ExpressionLimit	2 set-ups	TRUE	0	Uint8
10-05	Readout Transmit Error Counter	0 N/A	All set-ups	TRUE	0	Uint8
10-06	Readout Receive Error Counter	0 N/A	All set-ups	TRUE	0	Uint8
10-07	Readout Bus Off Counter	0 N/A	All set-ups	TRUE	0	Uint8
10-1* DeviceNet						
10-10	Process Data Type Selection	null	All set-ups	TRUE	-	Uint8
10-11	Process Data Config Write	ExpressionLimit	2 set-ups	TRUE	-	Uint16
10-12	Process Data Config Read	ExpressionLimit	2 set-ups	TRUE	-	Uint16
10-13	Warning Parameter	0 N/A	All set-ups	TRUE	0	Uint16
10-14	Net Reference	[0] Off	2 set-ups	TRUE	-	Uint8
10-15	Net Control	[0] Off	2 set-ups	TRUE	-	Uint8
10-2* COS Filters						
10-20	COS Filter 1	0 N/A	All set-ups	FALSE	0	Uint16
10-21	COS Filter 2	0 N/A	All set-ups	FALSE	0	Uint16
10-22	COS Filter 3	0 N/A	All set-ups	FALSE	0	Uint16
10-23	COS Filter 4	0 N/A	All set-ups	FALSE	0	Uint16
10-3* Parameter Access						
10-30	Array Index	0 N/A	2 set-ups	TRUE	0	Uint8
10-31	Store Data Values	[0] Off	All set-ups	TRUE	-	Uint8
10-32	Devicenet Revision	ExpressionLimit	All set-ups	TRUE	0	Uint16
10-33	Store Always	[0] Off	1 set-up	TRUE	-	Uint8
10-34	DeviceNet Product Code	ExpressionLimit	1 set-up	TRUE	0	Uint16
10-39	Devicenet F Parameters	0 N/A	All set-ups	TRUE	0	Uint32

Table 6.30



6.4.12 13-** Smart Logic

Par. No. #	Parameter description	Default value	4-set-up	Change during operation	Conversion index	Type
13-0* SLC Settings						
13-00	SL Controller Mode	null	2 set-ups	TRUE	-	Uint8
13-01	Start Event	null	2 set-ups	TRUE	-	Uint8
13-02	Stop Event	null	2 set-ups	TRUE	-	Uint8
13-03	Reset SLC	[0] Do not reset SLC	All set-ups	TRUE	-	Uint8
13-1* Comparators						
13-10	Comparator Operand	null	2 set-ups	TRUE	-	Uint8
13-11	Comparator Operator	null	2 set-ups	TRUE	-	Uint8
13-12	Comparator Value	ExpressionLimit	2 set-ups	TRUE	-3	Int32
13-2* Timers						
13-20	SL Controller Timer	ExpressionLimit	1 set-up	TRUE	-3	TimD
13-4* Logic Rules						
13-40	Logic Rule Boolean 1	null	2 set-ups	TRUE	-	Uint8
13-41	Logic Rule Operator 1	null	2 set-ups	TRUE	-	Uint8
13-42	Logic Rule Boolean 2	null	2 set-ups	TRUE	-	Uint8
13-43	Logic Rule Operator 2	null	2 set-ups	TRUE	-	Uint8
13-44	Logic Rule Boolean 3	null	2 set-ups	TRUE	-	Uint8
13-5* States						
13-51	SL Controller Event	null	2 set-ups	TRUE	-	Uint8
13-52	SL Controller Action	null	2 set-ups	TRUE	-	Uint8

Table 6.31



6.4.13 14-** Special Functions

6

Par. No. #	Parameter description	Default value	4-set-up	Change during operation	Conversion index	Type
14-0* Inverter Switching						
14-00	Switching Pattern	null	All set-ups	TRUE	-	UInt8
14-01	Switching Frequency	null	All set-ups	TRUE	-	UInt8
14-03	Overmodulation	[1] On	All set-ups	FALSE	-	UInt8
14-04	PWM Random	[0] Off	All set-ups	TRUE	-	UInt8
14-1* Mains On/Off						
14-10	Mains Failure	[0] No function	All set-ups	FALSE	-	UInt8
14-11	Mains Voltage at Mains Fault	ExpressionLimit	All set-ups	TRUE	0	UInt16
14-12	Function at Mains Imbalance	[3] Derate	All set-ups	TRUE	-	UInt8
14-2* Reset Functions						
14-20	Reset Mode	[10] Automatic reset x 10	All set-ups	TRUE	-	UInt8
14-21	Automatic Restart Time	10 s	All set-ups	TRUE	0	UInt16
14-22	Operation Mode	[0] Normal operation	All set-ups	TRUE	-	UInt8
14-23	Typecode Setting	null	2 set-ups	FALSE	-	UInt8
14-25	Trip Delay at Torque Limit	60 s	All set-ups	TRUE	0	UInt8
14-26	Trip Delay at Inverter Fault	ExpressionLimit	All set-ups	TRUE	0	UInt8
14-28	Production Settings	[0] No action	All set-ups	TRUE	-	UInt8
14-29	Service Code	0 N/A	All set-ups	TRUE	0	Int32
14-3* Current Limit Ctrl.						
14-30	Current Lim Ctrl, Proportional Gain	100 %	All set-ups	FALSE	0	UInt16
14-31	Current Lim Ctrl, Integration Time	0.020 s	All set-ups	FALSE	-3	UInt16
14-32	Current Lim Ctrl, Filter Time	27.0 ms	All set-ups	FALSE	-4	UInt16
14-4* Energy Optimising						
14-40	VT Level	66 %	All set-ups	FALSE	0	UInt8
14-41	AEO Minimum Magnetisation	ExpressionLimit	All set-ups	TRUE	0	UInt8
14-42	Minimum AEO Frequency	10 Hz	All set-ups	TRUE	0	UInt8
14-43	Motor Cosphi	ExpressionLimit	All set-ups	TRUE	-2	UInt16
14-5* Environment						
14-50	RFI Filter	[1] On	1 set-up	FALSE	-	UInt8
14-51	DC Link Compensation	[1] On	1 set-up	TRUE	-	UInt8
14-52	Fan Control	[0] Auto	All set-ups	TRUE	-	UInt8
14-53	Fan Monitor	[1] Warning	All set-ups	TRUE	-	UInt8
14-55	Output Filter	[0] No Filter	1 set-up	FALSE	-	UInt8
14-59	Actual Number of Inverter Units	ExpressionLimit	1 set-up	FALSE	0	UInt8
14-6* Auto Derate						
14-60	Function at Over Temperature	[1] Derate	All set-ups	TRUE	-	UInt8
14-61	Function at Inverter Overload	[1] Derate	All set-ups	TRUE	-	UInt8
14-62	Inv. Overload Derate Current	95 %	All set-ups	TRUE	0	UInt16
14-8* Options						
14-80	Option Supplied by External 24VDC	[0] No	2 set-ups	FALSE	-	UInt8
14-9* Fault Settings						
14-90	Fault Level	null	1 set-up	TRUE	-	UInt8

Table 6.32



6.4.14 15-** FC Information

Par. No. #	Parameter description	Default value	4-set-up	Change during operation	Conversion index	Type
15-0* Operating Data						
15-00	Operating Hours	0 h	All set-ups	FALSE	74	Uint32
15-01	Running Hours	0 h	All set-ups	FALSE	74	Uint32
15-02	kWh Counter	0 kWh	All set-ups	FALSE	75	Uint32
15-03	Power Up's	0 N/A	All set-ups	FALSE	0	Uint32
15-04	Over Temp's	0 N/A	All set-ups	FALSE	0	Uint16
15-05	Over Volt's	0 N/A	All set-ups	FALSE	0	Uint16
15-06	Reset kWh Counter	[0] Do not reset	All set-ups	TRUE	-	Uint8
15-07	Reset Running Hours Counter	[0] Do not reset	All set-ups	TRUE	-	Uint8
15-08	Number of Starts	0 N/A	All set-ups	FALSE	0	Uint32
15-1* Data Log Settings						
15-10	Logging Source	0	2 set-ups	TRUE	-	Uint16
15-11	Logging Interval	ExpressionLimit	2 set-ups	TRUE	-3	TimD
15-12	Trigger Event	[0] False	1 set-up	TRUE	-	Uint8
15-13	Logging Mode	[0] Log always	2 set-ups	TRUE	-	Uint8
15-14	Samples Before Trigger	50 N/A	2 set-ups	TRUE	0	Uint8
15-2* Historic Log						
15-20	Historic Log: Event	0 N/A	All set-ups	FALSE	0	Uint8
15-21	Historic Log: Value	0 N/A	All set-ups	FALSE	0	Uint32
15-22	Historic Log: Time	0 ms	All set-ups	FALSE	-3	Uint32
15-23	Historic Log: Date and Time	ExpressionLimit	All set-ups	FALSE	0	TimeOfDay
15-3* Alarm Log						
15-30	Alarm Log: Error Code	0 N/A	All set-ups	FALSE	0	Uint16
15-31	Alarm Log: Value	0 N/A	All set-ups	FALSE	0	Int16
15-32	Alarm Log: Time	0 s	All set-ups	FALSE	0	Uint32
15-33	Alarm Log: Date and Time	ExpressionLimit	All set-ups	FALSE	0	TimeOfDay
15-34	Alarm Log: Setpoint	0.000 ProcessCtrlUnit	All set-ups	FALSE	-3	Int32
15-35	Alarm Log: Feedback	0.000 ProcessCtrlUnit	All set-ups	FALSE	-3	Int32
15-36	Alarm Log: Current Demand	0 %	All set-ups	FALSE	0	Uint8
15-37	Alarm Log: Process Ctrl Unit	[0]	All set-ups	FALSE	-	Uint8
15-4* Drive Identification						
15-40	FC Type	0 N/A	All set-ups	FALSE	0	VisStr[6]
15-41	Power Section	0 N/A	All set-ups	FALSE	0	VisStr[20]
15-42	Voltage	0 N/A	All set-ups	FALSE	0	VisStr[20]
15-43	Software Version	0 N/A	All set-ups	FALSE	0	VisStr[5]
15-44	Ordered Typecode String	0 N/A	All set-ups	FALSE	0	VisStr[40]
15-45	Actual Typecode String	0 N/A	All set-ups	FALSE	0	VisStr[40]
15-46	Frequency Converter Ordering No	0 N/A	All set-ups	FALSE	0	VisStr[8]
15-47	Power Card Ordering No	0 N/A	All set-ups	FALSE	0	VisStr[8]
15-48	LCP Id No	0 N/A	All set-ups	FALSE	0	VisStr[20]
15-49	SW ID Control Card	0 N/A	All set-ups	FALSE	0	VisStr[20]
15-50	SW ID Power Card	0 N/A	All set-ups	FALSE	0	VisStr[20]
15-51	Frequency Converter Serial Number	0 N/A	All set-ups	FALSE	0	VisStr[10]
15-53	Power Card Serial Number	0 N/A	All set-ups	FALSE	0	VisStr[19]
15-6* Option Ident						
15-60	Option Mounted	0 N/A	All set-ups	FALSE	0	VisStr[30]
15-61	Option SW Version	0 N/A	All set-ups	FALSE	0	VisStr[20]
15-62	Option Ordering No	0 N/A	All set-ups	FALSE	0	VisStr[8]
15-63	Option Serial No	0 N/A	All set-ups	FALSE	0	VisStr[18]



Par. No. #	Parameter description	Default value	4-set-up	Change during operation	Conversion index	Type
15-70	Option in Slot A	0 N/A	All set-ups	FALSE	0	VisStr[30]
15-71	Slot A Option SW Version	0 N/A	All set-ups	FALSE	0	VisStr[20]
15-72	Option in Slot B	0 N/A	All set-ups	FALSE	0	VisStr[30]
15-73	Slot B Option SW Version	0 N/A	All set-ups	FALSE	0	VisStr[20]
15-74	Option in Slot C0	0 N/A	All set-ups	FALSE	0	VisStr[30]
15-75	Slot C0 Option SW Version	0 N/A	All set-ups	FALSE	0	VisStr[20]
15-76	Option in Slot C1	0 N/A	All set-ups	FALSE	0	VisStr[30]
15-77	Slot C1 Option SW Version	0 N/A	All set-ups	FALSE	0	VisStr[20]
15-9* Parameter Info						
15-92	Defined Parameters	0 N/A	All set-ups	FALSE	0	Uint16
15-93	Modified Parameters	0 N/A	All set-ups	FALSE	0	Uint16
15-98	Drive Identification	0 N/A	All set-ups	FALSE	0	VisStr[40]
15-99	Parameter Metadata	0 N/A	All set-ups	FALSE	0	Uint16

Table 6.33



6.4.15 16-** Data Readouts

Par. No. #	Parameter description	Default value	4-set-up	Change during operation	Conversion index	Type
16-0* General Status						
16-00	Control Word	0 N/A	All set-ups	TRUE	0	V2
16-01	Reference [Unit]	0.000 ReferenceFeed-backUnit	All set-ups	TRUE	-3	Int32
16-02	Reference [%]	0.0 %	All set-ups	TRUE	-1	Int16
16-03	Status Word	0 N/A	All set-ups	TRUE	0	V2
16-05	Main Actual Value [%]	0.00 %	All set-ups	TRUE	-2	N2
16-09	Custom Readout	0.00 CustomReadoutUnit	All set-ups	TRUE	-2	Int32
16-1* Motor Status						
16-10	Power [kW]	0.00 kW	All set-ups	TRUE	1	Int32
16-11	Power [hp]	0.00 hp	All set-ups	TRUE	-2	Int32
16-12	Motor Voltage	0.0 V	All set-ups	TRUE	-1	UInt16
16-13	Frequency	0.0 Hz	All set-ups	TRUE	-1	UInt16
16-14	Motor Current	0.00 A	All set-ups	TRUE	-2	Int32
16-15	Frequency [%]	0.00 %	All set-ups	TRUE	-2	N2
16-16	Torque [Nm]	0.0 Nm	All set-ups	TRUE	-1	Int32
16-17	Speed [RPM]	0 RPM	All set-ups	TRUE	67	Int32
16-18	Motor Thermal	0 %	All set-ups	TRUE	0	UInt8
16-22	Torque [%]	0 %	All set-ups	TRUE	0	Int16
16-3* Drive Status						
16-30	DC Link Voltage	0 V	All set-ups	TRUE	0	UInt16
16-32	Brake Energy /s	0.000 kW	All set-ups	TRUE	0	UInt32
16-33	Brake Energy /2 min	0.000 kW	All set-ups	TRUE	0	UInt32
16-34	Heatsink Temp.	0 °C	All set-ups	TRUE	100	UInt8
16-35	Inverter Thermal	0 %	All set-ups	TRUE	0	UInt8
16-36	Inv. Nom. Current	ExpressionLimit	All set-ups	TRUE	-2	UInt32
16-37	Inv. Max. Current	ExpressionLimit	All set-ups	TRUE	-2	UInt32
16-38	SL Controller State	0 N/A	All set-ups	TRUE	0	UInt8
16-39	Control Card Temp.	0 °C	All set-ups	TRUE	100	UInt8
16-40	Logging Buffer Full	[0] No	All set-ups	TRUE	-	UInt8
16-49	Current Fault Source	0 N/A	All set-ups	TRUE	0	UInt8
16-5* Ref. & Feedb.						
16-50	External Reference	0.0 N/A	All set-ups	TRUE	-1	Int16
16-52	Feedback [Unit]	0.000 ProcessCtrlUnit	All set-ups	TRUE	-3	Int32
16-53	Digi Pot Reference	0.00 N/A	All set-ups	TRUE	-2	Int16
16-54	Feedback 1 [Unit]	0.000 ProcessCtrlUnit	All set-ups	TRUE	-3	Int32
16-55	Feedback 2 [Unit]	0.000 ProcessCtrlUnit	All set-ups	TRUE	-3	Int32
16-56	Feedback 3 [Unit]	0.000 ProcessCtrlUnit	All set-ups	TRUE	-3	Int32
16-58	PID Output [%]	0.0 %	All set-ups	TRUE	-1	Int16
16-59	Adjusted Setpoint	0.000 ProcessCtrlUnit	All set-ups	TRUE	-3	Int32

Table 6.34



Par. No. #	Parameter description	Default value	4-set-up	Change during operation	Conversion index	Type
16-6* Inputs & Outputs						
16-60	Digital Input	0 N/A	All set-ups	TRUE	0	Uint16
16-61	Terminal 53 Switch Setting	[0] Current	All set-ups	TRUE	-	Uint8
16-62	Analog Input 53	0.000 N/A	All set-ups	TRUE	-3	Int32
16-63	Terminal 54 Switch Setting	[0] Current	All set-ups	TRUE	-	Uint8
16-64	Analog Input 54	0.000 N/A	All set-ups	TRUE	-3	Int32
16-65	Analog Output 42 [mA]	0.000 N/A	All set-ups	TRUE	-3	Int16
16-66	Digital Output [bin]	0 N/A	All set-ups	TRUE	0	Int16
16-67	Pulse Input #29 [Hz]	0 N/A	All set-ups	TRUE	0	Int32
16-68	Pulse Input #33 [Hz]	0 N/A	All set-ups	TRUE	0	Int32
16-69	Pulse Output #27 [Hz]	0 N/A	All set-ups	TRUE	0	Int32
16-70	Pulse Output #29 [Hz]	0 N/A	All set-ups	TRUE	0	Int32
16-71	Relay Output [bin]	0 N/A	All set-ups	TRUE	0	Uint16
16-72	Counter A	0 N/A	All set-ups	TRUE	0	Int32
16-73	Counter B	0 N/A	All set-ups	TRUE	0	Int32
16-75	Analog In X30/11	0.000 N/A	All set-ups	TRUE	-3	Int32
16-76	Analog In X30/12	0.000 N/A	All set-ups	TRUE	-3	Int32
16-77	Analog Out X30/8 [mA]	0.000 N/A	All set-ups	TRUE	-3	Int16
16-8* Fieldbus & FC Port						
16-80	Fieldbus CTW 1	0 N/A	All set-ups	TRUE	0	V2
16-82	Fieldbus REF 1	0 N/A	All set-ups	TRUE	0	N2
16-84	Comm. Option STW	0 N/A	All set-ups	TRUE	0	V2
16-85	FC Port CTW 1	0 N/A	All set-ups	FALSE	0	V2
16-86	FC Port REF 1	0 N/A	All set-ups	FALSE	0	N2
16-9* Diagnosis Readouts						
16-90	Alarm Word	0 N/A	All set-ups	TRUE	0	Uint32
16-91	Alarm Word 2	0 N/A	All set-ups	TRUE	0	Uint32
16-92	Warning Word	0 N/A	All set-ups	TRUE	0	Uint32
16-93	Warning Word 2	0 N/A	All set-ups	TRUE	0	Uint32
16-94	Ext. Status Word	0 N/A	All set-ups	TRUE	0	Uint32
16-95	Ext. Status Word 2	0 N/A	All set-ups	TRUE	0	Uint32
16-96	Maintenance Word	0 N/A	All set-ups	TRUE	0	Uint32

Table 6.35



6.4.16 18-** Data Readouts 2

Par. No. #	Parameter description	Default value	4-set-up	Change during operation	Conversion index	Type
18-0* Maintenance Log						
18-00	Maintenance Log: Item	0 N/A	All set-ups	FALSE	0	Uint8
18-01	Maintenance Log: Action	0 N/A	All set-ups	FALSE	0	Uint8
18-02	Maintenance Log: Time	0 s	All set-ups	FALSE	0	Uint32
18-03	Maintenance Log: Date and Time	ExpressionLimit	All set-ups	FALSE	0	TimeOf Day
18-3* Analog Readouts						
18-30	Analog Input X42/1	0.000 N/A	All set-ups	FALSE	-3	Int32
18-31	Analog Input X42/3	0.000 N/A	All set-ups	FALSE	-3	Int32
18-32	Analog Input X42/5	0.000 N/A	All set-ups	FALSE	-3	Int32
18-33	Analog Out X42/7 [V]	0.000 N/A	All set-ups	FALSE	-3	Int16
18-34	Analog Out X42/9 [V]	0.000 N/A	All set-ups	FALSE	-3	Int16
18-35	Analog Out X42/11 [V]	0.000 N/A	All set-ups	FALSE	-3	Int16
18-36	Analog Input X48/2 [mA]	0.000 N/A	All set-ups	TRUE	-3	Int32
18-37	Temp. Input X48/4	0 N/A	All set-ups	TRUE	0	Int16
18-38	Temp. Input X48/7	0 N/A	All set-ups	TRUE	0	Int16
18-39	Temp. Input X48/10	0 N/A	All set-ups	TRUE	0	Int16
18-6* Inputs & Outputs 2						
18-60	Digital Input 2	0 N/A	All set-ups	TRUE	0	Uint16

6

Table 6.36



6.4.17 20-** FC Closed Loop

6

Par. No. #	Parameter description	Default value	4-set-up	Change during operation	Conversion index	Type
20-0* Feedback						
20-00	Feedback 1 Source	[2] Analog input 54	All set-ups	TRUE	-	UInt8
20-01	Feedback 1 Conversion	[0] Linear	All set-ups	FALSE	-	UInt8
20-02	Feedback 1 Source Unit	null	All set-ups	TRUE	-	UInt8
20-03	Feedback 2 Source	[0] No function	All set-ups	TRUE	-	UInt8
20-04	Feedback 2 Conversion	[0] Linear	All set-ups	FALSE	-	UInt8
20-05	Feedback 2 Source Unit	null	All set-ups	TRUE	-	UInt8
20-06	Feedback 3 Source	[0] No function	All set-ups	TRUE	-	UInt8
20-07	Feedback 3 Conversion	[0] Linear	All set-ups	FALSE	-	UInt8
20-08	Feedback 3 Source Unit	null	All set-ups	TRUE	-	UInt8
20-12	Reference/Feedback Unit	null	All set-ups	TRUE	-	UInt8
20-2* Feedback/Setpoint						
20-20	Feedback Function	[4] Maximum	All set-ups	TRUE	-	UInt8
20-21	Setpoint 1	0.000 ProcessCtrlUnit	All set-ups	TRUE	-3	Int32
20-22	Setpoint 2	0.000 ProcessCtrlUnit	All set-ups	TRUE	-3	Int32
20-23	Setpoint 3	0.000 ProcessCtrlUnit	All set-ups	TRUE	-3	Int32
20-7* PID Autotuning						
20-70	Closed Loop Type	[0] Auto	2 set-ups	TRUE	-	UInt8
20-71	PID Performance	[0] Normal	2 set-ups	TRUE	-	UInt8
20-72	PID Output Change	0.10 N/A	2 set-ups	TRUE	-2	UInt16
20-73	Minimum Feedback Level	-999999.000 ProcessCtrlUnit	2 set-ups	TRUE	-3	Int32
20-74	Maximum Feedback Level	999999.000 ProcessCtrlUnit	2 set-ups	TRUE	-3	Int32
20-79	PID Autotuning	[0] Disabled	All set-ups	TRUE	-	UInt8
20-8* PID Basic Settings						
20-81	PID Normal/ Inverse Control	[0] Normal	All set-ups	TRUE	-	UInt8
20-82	PID Start Speed [RPM]	ExpressionLimit	All set-ups	TRUE	67	UInt16
20-83	PID Start Speed [Hz]	ExpressionLimit	All set-ups	TRUE	-1	UInt16
20-84	On Reference Bandwidth	5 %	All set-ups	TRUE	0	UInt8
20-9* PID Controller						
20-91	PID Anti Windup	[1] On	All set-ups	TRUE	-	UInt8
20-93	PID Proportional Gain	2.00 N/A	All set-ups	TRUE	-2	UInt16
20-94	PID Integral Time	8.00 s	All set-ups	TRUE	-2	UInt32
20-95	PID Differentiation Time	0.00 s	All set-ups	TRUE	-2	UInt16
20-96	PID Diff. Gain Limit	5.0 N/A	All set-ups	TRUE	-1	UInt16

Table 6.37



6.4.18 21-** Ext. Closed Loop

Par. No. #	Parameter description	Default value	4-set-up	Change during operation	Conversion index	Type
21-0* Ext. CL Autotuning						
21-00	Closed Loop Type	[0] Auto	2 set-ups	TRUE	-	Uint8
21-01	PID Performance	[0] Normal	2 set-ups	TRUE	-	Uint8
21-02	PID Output Change	0.10 N/A	2 set-ups	TRUE	-2	Uint16
21-03	Minimum Feedback Level	-999999.000 N/A	2 set-ups	TRUE	-3	Int32
21-04	Maximum Feedback Level	999999.000 N/A	2 set-ups	TRUE	-3	Int32
21-09	PID Auto Tuning	[0] Disabled	All set-ups	TRUE	-	Uint8
21-1* Ext. CL 1 Ref./Fb.						
21-10	Ext. 1 Ref./Feedback Unit	[0]	All set-ups	TRUE	-	Uint8
21-11	Ext. 1 Minimum Reference	0.000 ExtPID1Unit	All set-ups	TRUE	-3	Int32
21-12	Ext. 1 Maximum Reference	100.000 ExtPID1Unit	All set-ups	TRUE	-3	Int32
21-13	Ext. 1 Reference Source	[0] No function	All set-ups	TRUE	-	Uint8
21-14	Ext. 1 Feedback Source	[0] No function	All set-ups	TRUE	-	Uint8
21-15	Ext. 1 Setpoint	0.000 ExtPID1Unit	All set-ups	TRUE	-3	Int32
21-17	Ext. 1 Reference [Unit]	0.000 ExtPID1Unit	All set-ups	TRUE	-3	Int32
21-18	Ext. 1 Feedback [Unit]	0.000 ExtPID1Unit	All set-ups	TRUE	-3	Int32
21-19	Ext. 1 Output [%]	0 %	All set-ups	TRUE	0	Int32
21-2* Ext. CL 1 PID						
21-20	Ext. 1 Normal/Inverse Control	[0] Normal	All set-ups	TRUE	-	Uint8
21-21	Ext. 1 Proportional Gain	0.50 N/A	All set-ups	TRUE	-2	Uint16
21-22	Ext. 1 Integral Time	20.00 s	All set-ups	TRUE	-2	Uint32
21-23	Ext. 1 Differentiation Time	0.00 s	All set-ups	TRUE	-2	Uint16
21-24	Ext. 1 Dif. Gain Limit	5.0 N/A	All set-ups	TRUE	-1	Uint16
21-3* Ext. CL 2 Ref./Fb.						
21-30	Ext. 2 Ref./Feedback Unit	[0]	All set-ups	TRUE	-	Uint8
21-31	Ext. 2 Minimum Reference	0.000 ExtPID2Unit	All set-ups	TRUE	-3	Int32
21-32	Ext. 2 Maximum Reference	100.000 ExtPID2Unit	All set-ups	TRUE	-3	Int32
21-33	Ext. 2 Reference Source	[0] No function	All set-ups	TRUE	-	Uint8
21-34	Ext. 2 Feedback Source	[0] No function	All set-ups	TRUE	-	Uint8
21-35	Ext. 2 Setpoint	0.000 ExtPID2Unit	All set-ups	TRUE	-3	Int32
21-37	Ext. 2 Reference [Unit]	0.000 ExtPID2Unit	All set-ups	TRUE	-3	Int32
21-38	Ext. 2 Feedback [Unit]	0.000 ExtPID2Unit	All set-ups	TRUE	-3	Int32
21-39	Ext. 2 Output [%]	0 %	All set-ups	TRUE	0	Int32
21-4* Ext. CL 2 PID						
21-40	Ext. 2 Normal/Inverse Control	[0] Normal	All set-ups	TRUE	-	Uint8
21-41	Ext. 2 Proportional Gain	0.50 N/A	All set-ups	TRUE	-2	Uint16
21-42	Ext. 2 Integral Time	20.00 s	All set-ups	TRUE	-2	Uint32
21-43	Ext. 2 Differentiation Time	0.00 s	All set-ups	TRUE	-2	Uint16
21-44	Ext. 2 Dif. Gain Limit	5.0 N/A	All set-ups	TRUE	-1	Uint16
21-5* Ext. CL 3 Ref./Fb.						
21-50	Ext. 3 Ref./Feedback Unit	[0]	All set-ups	TRUE	-	Uint8
21-51	Ext. 3 Minimum Reference	0.000 ExtPID3Unit	All set-ups	TRUE	-3	Int32
21-52	Ext. 3 Maximum Reference	100.000 ExtPID3Unit	All set-ups	TRUE	-3	Int32
21-53	Ext. 3 Reference Source	[0] No function	All set-ups	TRUE	-	Uint8
21-54	Ext. 3 Feedback Source	[0] No function	All set-ups	TRUE	-	Uint8
21-55	Ext. 3 Setpoint	0.000 ExtPID3Unit	All set-ups	TRUE	-3	Int32
21-57	Ext. 3 Reference [Unit]	0.000 ExtPID3Unit	All set-ups	TRUE	-3	Int32
21-58	Ext. 3 Feedback [Unit]	0.000 ExtPID3Unit	All set-ups	TRUE	-3	Int32
21-59	Ext. 3 Output [%]	0 %	All set-ups	TRUE	0	Int32



Par. No. #	Parameter description	Default value	4-set-up	Change during operation	Conversion index	Type
21-6* Ext. CL 3 PID						
21-60	Ext. 3 Normal/Inverse Control	[0] Normal	All set-ups	TRUE	-	Uint8
21-61	Ext. 3 Proportional Gain	0.50 N/A	All set-ups	TRUE	-2	Uint16
21-62	Ext. 3 Integral Time	20.00 s	All set-ups	TRUE	-2	Uint32
21-63	Ext. 3 Differentiation Time	0.00 s	All set-ups	TRUE	-2	Uint16
21-64	Ext. 3 Dif. Gain Limit	5.0 N/A	All set-ups	TRUE	-1	Uint16

Table 6.38



6.4.19 22-** Application Functions

Par. No. #	Parameter description	Default value	4-set-up	Change during operation	Conversion index	Type
22-0* Miscellaneous						
22-00	External Interlock Delay	0 s	All set-ups	TRUE	0	Uint16
22-2* No-Flow Detection						
22-20	Low Power Auto Set-up	[0] Off	All set-ups	FALSE	-	Uint8
22-21	Low Power Detection	[0] Disabled	All set-ups	TRUE	-	Uint8
22-22	Low Speed Detection	[0] Disabled	All set-ups	TRUE	-	Uint8
22-23	No-Flow Function	[0] Off	All set-ups	TRUE	-	Uint8
22-24	No-Flow Delay	10 s	All set-ups	TRUE	0	Uint16
22-26	Dry Pump Function	[0] Off	All set-ups	TRUE	-	Uint8
22-27	Dry Pump Delay	10 s	All set-ups	TRUE	0	Uint16
22-28	No-Flow Low Speed [RPM]	ExpressionLimit	All set-ups	TRUE	67	Uint16
22-29	No-Flow Low Speed [Hz]	ExpressionLimit	All set-ups	TRUE	-1	Uint16
22-3* No-Flow Power Tuning						
22-30	No-Flow Power	0.00 kW	All set-ups	TRUE	1	Uint32
22-31	Power Correction Factor	100 %	All set-ups	TRUE	0	Uint16
22-32	Low Speed [RPM]	ExpressionLimit	All set-ups	TRUE	67	Uint16
22-33	Low Speed [Hz]	ExpressionLimit	All set-ups	TRUE	-1	Uint16
22-34	Low Speed Power [kW]	ExpressionLimit	All set-ups	TRUE	1	Uint32
22-35	Low Speed Power [HP]	ExpressionLimit	All set-ups	TRUE	-2	Uint32
22-36	High Speed [RPM]	ExpressionLimit	All set-ups	TRUE	67	Uint16
22-37	High Speed [Hz]	ExpressionLimit	All set-ups	TRUE	-1	Uint16
22-38	High Speed Power [kW]	ExpressionLimit	All set-ups	TRUE	1	Uint32
22-39	High Speed Power [HP]	ExpressionLimit	All set-ups	TRUE	-2	Uint32
22-4* Sleep Mode						
22-40	Minimum Run Time	60 s	All set-ups	TRUE	0	Uint16
22-41	Minimum Sleep Time	30 s	All set-ups	TRUE	0	Uint16
22-42	Wake-up Speed [RPM]	ExpressionLimit	All set-ups	TRUE	67	Uint16
22-43	Wake-up Speed [Hz]	ExpressionLimit	All set-ups	TRUE	-1	Uint16
22-44	Wake-up Ref./FB Difference	10 %	All set-ups	TRUE	0	Int8
22-45	Setpoint Boost	0 %	All set-ups	TRUE	0	Int8
22-46	Maximum Boost Time	60 s	All set-ups	TRUE	0	Uint16
22-5* End of Curve						
22-50	End of Curve Function	[0] Off	All set-ups	TRUE	-	Uint8
22-51	End of Curve Delay	10 s	All set-ups	TRUE	0	Uint16
22-6* Broken Belt Detection						
22-60	Broken Belt Function	[0] Off	All set-ups	TRUE	-	Uint8
22-61	Broken Belt Torque	10 %	All set-ups	TRUE	0	Uint8
22-62	Broken Belt Delay	10 s	All set-ups	TRUE	0	Uint16
22-7* Short Cycle Protection						
22-75	Short Cycle Protection	[0] Disabled	All set-ups	TRUE	-	Uint8
22-76	Interval between Starts	start_to_start_min_on_time (P2277)	All set-ups	TRUE	0	Uint16
22-77	Minimum Run Time	0 s	All set-ups	TRUE	0	Uint16
22-78	Minimum Run Time Override	[0] Disabled	All set-ups	FALSE	-	Uint8
22-79	Minimum Run Time Override Value	0.000 ProcessCtrlUnit	All set-ups	TRUE	-3	Int32

Table 6.39



Par. No. #	Parameter description	Default value	4-set-up	Change during operation	Conversion index	Type
22-8* Flow Compensation						
22-80	Flow Compensation	[0] Disabled	All set-ups	TRUE	-	Uint8
22-81	Square-linear Curve Approximation	100 %	All set-ups	TRUE	0	Uint8
22-82	Work Point Calculation	[0] Disabled	All set-ups	TRUE	-	Uint8
22-83	Speed at No-Flow [RPM]	ExpressionLimit	All set-ups	TRUE	67	Uint16
22-84	Speed at No-Flow [Hz]	ExpressionLimit	All set-ups	TRUE	-1	Uint16
22-85	Speed at Design Point [RPM]	ExpressionLimit	All set-ups	TRUE	67	Uint16
22-86	Speed at Design Point [Hz]	ExpressionLimit	All set-ups	TRUE	-1	Uint16
22-87	Pressure at No-Flow Speed	0.000 N/A	All set-ups	TRUE	-3	Int32
22-88	Pressure at Rated Speed	999999.999 N/A	All set-ups	TRUE	-3	Int32
22-89	Flow at Design Point	0.000 N/A	All set-ups	TRUE	-3	Int32
22-90	Flow at Rated Speed	0.000 N/A	All set-ups	TRUE	-3	Int32

Table 6.40



6.4.20 23-** Timed Actions

Par. No. #	Parameter description	Default value	4-set-up	Change during operation	Conversion index	Type
23-0* Timed Actions						
23-00	ON Time	ExpressionLimit	2 set-ups	TRUE	0	TimeOfDay-WoDate
23-01	ON Action	[0] Disabled	2 set-ups	TRUE	-	UInt8
23-02	OFF Time	ExpressionLimit	2 set-ups	TRUE	0	TimeOfDay-WoDate
23-03	OFF Action	[0] Disabled	2 set-ups	TRUE	-	UInt8
23-04	Occurrence	[0] All days	2 set-ups	TRUE	-	UInt8
23-1* Maintenance						
23-10	Maintenance Item	[1] Motor bearings	1 set-up	TRUE	-	UInt8
23-11	Maintenance Action	[1] Lubricate	1 set-up	TRUE	-	UInt8
23-12	Maintenance Time Base	[0] Disabled	1 set-up	TRUE	-	UInt8
23-13	Maintenance Time Interval	1 h	1 set-up	TRUE	74	UInt32
23-14	Maintenance Date and Time	ExpressionLimit	1 set-up	TRUE	0	TimeOfDay
23-1* Maintenance Reset						
23-15	Reset Maintenance Word	[0] Do not reset	All set-ups	TRUE	-	UInt8
23-16	Maintenance Text	0 N/A	1 set-up	TRUE	0	VisStr[20]
23-5* Energy Log						
23-50	Energy Log Resolution	[5] Last 24 Hours	2 set-ups	TRUE	-	UInt8
23-51	Period Start	ExpressionLimit	2 set-ups	TRUE	0	TimeOfDay
23-53	Energy Log	0 N/A	All set-ups	TRUE	0	UInt32
23-54	Reset Energy Log	[0] Do not reset	All set-ups	TRUE	-	UInt8
23-6* Trending						
23-60	Trend Variable	[0] Power [kW]	2 set-ups	TRUE	-	UInt8
23-61	Continuous Bin Data	0 N/A	All set-ups	TRUE	0	UInt32
23-62	Timed Bin Data	0 N/A	All set-ups	TRUE	0	UInt32
23-63	Timed Period Start	ExpressionLimit	2 set-ups	TRUE	0	TimeOfDay
23-64	Timed Period Stop	ExpressionLimit	2 set-ups	TRUE	0	TimeOfDay
23-65	Minimum Bin Value	ExpressionLimit	2 set-ups	TRUE	0	UInt8
23-66	Reset Continuous Bin Data	[0] Do not reset	All set-ups	TRUE	-	UInt8
23-67	Reset Timed Bin Data	[0] Do not reset	All set-ups	TRUE	-	UInt8
23-8* Payback Counter						
23-80	Power Reference Factor	100 %	2 set-ups	TRUE	0	UInt8
23-81	Energy Cost	1.00 N/A	2 set-ups	TRUE	-2	UInt32
23-82	Investment	0 N/A	2 set-ups	TRUE	0	UInt32
23-83	Energy Savings	0 kWh	All set-ups	TRUE	75	Int32
23-84	Cost Savings	0 N/A	All set-ups	TRUE	0	Int32

Table 6.41



6.4.21 25-** Cascade Controller

6

Par. No. #	Parameter description	Default value	4-set-up	Change during operation	Conversion index	Type
25-0* System Settings						
25-00	Cascade Controller	null	2 set-ups	FALSE	-	Uint8
25-02	Motor Start	[0] Direct on Line	2 set-ups	FALSE	-	Uint8
25-04	Pump Cycling	null	All set-ups	TRUE	-	Uint8
25-05	Fixed Lead Pump	null	2 set-ups	FALSE	-	Uint8
25-06	Number of Pumps	2 N/A	2 set-ups	FALSE	0	Uint8
25-2* Bandwidth Settings						
25-20	Staging Bandwidth	ExpressionLimit	All set-ups	TRUE	0	Uint8
25-21	Override Bandwidth	100 %	All set-ups	TRUE	0	Uint8
25-22	Fixed Speed Bandwidth	casco_staging_bandwidth (P2520)	All set-ups	TRUE	0	Uint8
25-23	SBW Staging Delay	15 s	All set-ups	TRUE	0	Uint16
25-24	SBW Destaging Delay	15 s	All set-ups	TRUE	0	Uint16
25-25	OBW Time	10 s	All set-ups	TRUE	0	Uint16
25-26	Destage At No-Flow	[0] Disabled	All set-ups	TRUE	-	Uint8
25-27	Stage Function	null	All set-ups	TRUE	-	Uint8
25-28	Stage Function Time	15 s	All set-ups	TRUE	0	Uint16
25-29	Destage Function	null	All set-ups	TRUE	-	Uint8
25-30	Destage Function Time	15 s	All set-ups	TRUE	0	Uint16
25-4* Staging Settings						
25-40	Ramp Down Delay	10.0 s	All set-ups	TRUE	-1	Uint16
25-41	Ramp Up Delay	2.0 s	All set-ups	TRUE	-1	Uint16
25-42	Staging Threshold	ExpressionLimit	All set-ups	TRUE	0	Uint8
25-43	Destaging Threshold	ExpressionLimit	All set-ups	TRUE	0	Uint8
25-44	Staging Speed [RPM]	0 RPM	All set-ups	TRUE	67	Uint16
25-45	Staging Speed [Hz]	0.0 Hz	All set-ups	TRUE	-1	Uint16
25-46	Destaging Speed [RPM]	0 RPM	All set-ups	TRUE	67	Uint16
25-47	Destaging Speed [Hz]	0.0 Hz	All set-ups	TRUE	-1	Uint16
25-5* Alternation Settings						
25-50	Lead Pump Alternation	null	All set-ups	TRUE	-	Uint8
25-51	Alternation Event	[0] External	All set-ups	TRUE	-	Uint8
25-52	Alternation Time Interval	24 h	All set-ups	TRUE	74	Uint16
25-53	Alternation Timer Value	0 N/A	All set-ups	TRUE	0	VisStr[7]
25-54	Alternation Predefined Time	ExpressionLimit	All set-ups	TRUE	0	TimeOfDay-WoDate
25-55	Alternate if Load < 50%	[1] Enabled	All set-ups	TRUE	-	Uint8
25-56	Staging Mode at Alternation	[0] Slow	All set-ups	TRUE	-	Uint8
25-58	Run Next Pump Delay	0.1 s	All set-ups	TRUE	-1	Uint16
25-59	Run on Mains Delay	0.5 s	All set-ups	TRUE	-1	Uint16
25-8* Status						
25-80	Cascade Status	0 N/A	All set-ups	TRUE	0	VisStr[25]
25-81	Pump Status	0 N/A	All set-ups	TRUE	0	VisStr[25]
25-82	Lead Pump	0 N/A	All set-ups	TRUE	0	Uint8
25-83	Relay Status	0 N/A	All set-ups	TRUE	0	VisStr[4]
25-84	Pump ON Time	0 h	All set-ups	TRUE	74	Uint32
25-85	Relay ON Time	0 h	All set-ups	TRUE	74	Uint32
25-86	Reset Relay Counters	[0] Do not reset	All set-ups	TRUE	-	Uint8
25-9* Service						
25-90	Pump Interlock	[0] Off	All set-ups	TRUE	-	Uint8



Par. No. #	Parameter description	Default value	4-set-up	Change during operation	Conversion index	Type
25-91	Manual Alternation	0 N/A	All set-ups	TRUE	0	Uint8

Table 6.42



6.4.22 26-** Analog I/O Option MCB 109

6

Par. No. #	Parameter description	Default value	4-set-up	Change during operation	Conversion index	Type
26-0* Analog I/O Mode						
26-00	Terminal X42/1 Mode	[1] Voltage	All set-ups	TRUE	-	Uint8
26-01	Terminal X42/3 Mode	[1] Voltage	All set-ups	TRUE	-	Uint8
26-02	Terminal X42/5 Mode	[1] Voltage	All set-ups	TRUE	-	Uint8
26-1* Analog Input X42/1						
26-10	Terminal X42/1 Low Voltage	0.07 V	All set-ups	TRUE	-2	Int16
26-11	Terminal X42/1 High Voltage	10.00 V	All set-ups	TRUE	-2	Int16
26-14	Term. X42/1 Low Ref./Feedb. Value	0.000 N/A	All set-ups	TRUE	-3	Int32
26-15	Term. X42/1 High Ref./Feedb. Value	100.000 N/A	All set-ups	TRUE	-3	Int32
26-16	Term. X42/1 Filter Time Constant	0.001 s	All set-ups	TRUE	-3	Uint16
26-17	Term. X42/1 Live Zero	[1] Enabled	All set-ups	TRUE	-	Uint8
26-2* Analog Input X42/3						
26-20	Terminal X42/3 Low Voltage	0.07 V	All set-ups	TRUE	-2	Int16
26-21	Terminal X42/3 High Voltage	10.00 V	All set-ups	TRUE	-2	Int16
26-24	Term. X42/3 Low Ref./Feedb. Value	0.000 N/A	All set-ups	TRUE	-3	Int32
26-25	Term. X42/3 High Ref./Feedb. Value	100.000 N/A	All set-ups	TRUE	-3	Int32
26-26	Term. X42/3 Filter Time Constant	0.001 s	All set-ups	TRUE	-3	Uint16
26-27	Term. X42/3 Live Zero	[1] Enabled	All set-ups	TRUE	-	Uint8
26-3* Analog Input X42/5						
26-30	Terminal X42/5 Low Voltage	0.07 V	All set-ups	TRUE	-2	Int16
26-31	Terminal X42/5 High Voltage	10.00 V	All set-ups	TRUE	-2	Int16
26-34	Term. X42/5 Low Ref./Feedb. Value	0.000 N/A	All set-ups	TRUE	-3	Int32
26-35	Term. X42/5 High Ref./Feedb. Value	100.000 N/A	All set-ups	TRUE	-3	Int32
26-36	Term. X42/5 Filter Time Constant	0.001 s	All set-ups	TRUE	-3	Uint16
26-37	Term. X42/5 Live Zero	[1] Enabled	All set-ups	TRUE	-	Uint8
26-4* Analog Out X42/7						
26-40	Terminal X42/7 Output	[0] No operation	All set-ups	TRUE	-	Uint8
26-41	Terminal X42/7 Min. Scale	0.00 %	All set-ups	TRUE	-2	Int16
26-42	Terminal X42/7 Max. Scale	100.00 %	All set-ups	TRUE	-2	Int16
26-43	Terminal X42/7 Bus Control	0.00 %	All set-ups	TRUE	-2	N2
26-44	Terminal X42/7 Timeout Preset	0.00 %	1 set-up	TRUE	-2	Uint16
26-5* Analog Out X42/9						
26-50	Terminal X42/9 Output	[0] No operation	All set-ups	TRUE	-	Uint8
26-51	Terminal X42/9 Min. Scale	0.00 %	All set-ups	TRUE	-2	Int16
26-52	Terminal X42/9 Max. Scale	100.00 %	All set-ups	TRUE	-2	Int16
26-53	Terminal X42/9 Bus Control	0.00 %	All set-ups	TRUE	-2	N2
26-54	Terminal X42/9 Timeout Preset	0.00 %	1 set-up	TRUE	-2	Uint16
26-6* Analog Out X42/11						
26-60	Terminal X42/11 Output	[0] No operation	All set-ups	TRUE	-	Uint8
26-61	Terminal X42/11 Min. Scale	0.00 %	All set-ups	TRUE	-2	Int16
26-62	Terminal X42/11 Max. Scale	100.00 %	All set-ups	TRUE	-2	Int16
26-63	Terminal X42/11 Bus Control	0.00 %	All set-ups	TRUE	-2	N2
26-64	Terminal X42/11 Timeout Preset	0.00 %	1 set-up	TRUE	-2	Uint16

Table 6.43



6.4.23 27-** Cascade CTL Option

Par. No. #	Parameter description	Default value	4-set-up	Change during operation	Conversion index	Type
27-0* Control & Status						
27-01	Pump Status	[0] Ready	All set-ups	TRUE	-	UInt8
27-02	Manual Pump Control	[0] No Operation	2 set-ups	TRUE	-	UInt8
27-03	Current Runtime Hours	0 h	All set-ups	TRUE	74	UInt32
27-04	Pump Total Lifetime Hours	0 h	All set-ups	TRUE	74	UInt32
27-1* Configuration						
27-10	Cascade Controller	null	2 set-ups	FALSE	-	UInt8
27-11	Number Of Drives	ExpressionLimit	2 set-ups	FALSE	0	UInt8
27-12	Number Of Pumps	ExpressionLimit	2 set-ups	FALSE	0	UInt8
27-14	Pump Capacity	100 %	2 set-ups	FALSE	0	UInt16
27-16	Runtime Balancing	[0] Balanced Priority 1	2 set-ups	TRUE	-	UInt8
27-17	Motor Starters	[0] Direct Online	2 set-ups	FALSE	-	UInt8
27-18	Spin Time for Unused Pumps	ExpressionLimit	All set-ups	TRUE	0	UInt16
27-19	Reset Current Runtime Hours	[0] Do not reset	All set-ups	TRUE	-	UInt8
27-2* Bandwidth Settings						
27-20	Normal Operating Range	ExpressionLimit	All set-ups	TRUE	0	UInt8
27-21	Override Limit	100 %	All set-ups	TRUE	0	UInt8
27-22	Fixed Speed Only Operating Range	ExpressionLimit	All set-ups	TRUE	0	UInt8
27-23	Staging Delay	15 s	All set-ups	TRUE	0	UInt16
27-24	Destaging Delay	15 s	All set-ups	TRUE	0	UInt16
27-25	Override Hold Time	10 s	All set-ups	TRUE	0	UInt16
27-27	Min Speed Destage Delay	ExpressionLimit	All set-ups	TRUE	0	UInt16
27-3* Staging Speed						
27-30	Auto Tune Staging Speeds	[1] Enabled	All set-ups	TRUE	-	UInt8
27-31	Stage On Speed [RPM]	ExpressionLimit	All set-ups	TRUE	67	UInt16
27-32	Stage On Speed [Hz]	ExpressionLimit	All set-ups	TRUE	-1	UInt16
27-33	Stage Off Speed [RPM]	ExpressionLimit	All set-ups	TRUE	67	UInt16
27-34	Stage Off Speed [Hz]	ExpressionLimit	All set-ups	TRUE	-1	UInt16
27-4* Staging Settings						
27-40	Auto Tune Staging Settings	[0] Disabled	All set-ups	TRUE	-	UInt8
27-41	Ramp Down Delay	10.0 s	All set-ups	TRUE	-1	UInt16
27-42	Ramp Up Delay	2.0 s	All set-ups	TRUE	-1	UInt16
27-43	Staging Threshold	ExpressionLimit	All set-ups	TRUE	0	UInt8
27-44	Destaging Threshold	ExpressionLimit	All set-ups	TRUE	0	UInt8
27-45	Staging Speed [RPM]	0 RPM	All set-ups	TRUE	67	UInt16
27-46	Staging Speed [Hz]	0.0 Hz	All set-ups	TRUE	-1	UInt16
27-47	Destaging Speed [RPM]	0 RPM	All set-ups	TRUE	67	UInt16
27-48	Destaging Speed [Hz]	0.0 Hz	All set-ups	TRUE	-1	UInt16
27-5* Alternate Settings						
27-50	Automatic Alternation	[0] Disabled	All set-ups	FALSE	-	UInt8
27-51	Alternation Event	null	All set-ups	TRUE	-	UInt8
27-52	Alternation Time Interval	0 min	All set-ups	TRUE	70	UInt16
27-53	Alternation Timer Value	0 min	All set-ups	TRUE	70	UInt16
27-54	Alternation At Time of Day	[0] Disabled	All set-ups	TRUE	-	UInt8
27-55	Alternation Predefined Time	ExpressionLimit	All set-ups	TRUE	0	TimeOfDay-WoDate
27-56	Alternate Capacity is <	0 %	All set-ups	TRUE	0	UInt8
27-58	Run Next Pump Delay	0.1 s	All set-ups	TRUE	-1	UInt16
27-6* Digital Inputs						



Par. No. #	Parameter description	Default value	4-set-up	Change during operation	Conversion index	Type
27-60	Terminal X66/1 Digital Input	[0] No operation	All set-ups	TRUE	-	Uint8
27-61	Terminal X66/3 Digital Input	[0] No operation	All set-ups	TRUE	-	Uint8
27-62	Terminal X66/5 Digital Input	[0] No operation	All set-ups	TRUE	-	Uint8
27-63	Terminal X66/7 Digital Input	[0] No operation	All set-ups	TRUE	-	Uint8
27-64	Terminal X66/9 Digital Input	[0] No operation	All set-ups	TRUE	-	Uint8
27-65	Terminal X66/11 Digital Input	[0] No operation	All set-ups	TRUE	-	Uint8
27-66	Terminal X66/13 Digital Input	[0] No operation	All set-ups	TRUE	-	Uint8
27-7* Connections						
27-70	Relay	[0] Standard Relay	2 set-ups	FALSE	-	Uint8
27-9* Readouts						
27-91	Cascade Reference	0.0 %	All set-ups	TRUE	-1	Int16
27-92	% Of Total Capacity	0 %	All set-ups	TRUE	0	Uint16
27-93	Cascade Option Status	[0] Disabled	All set-ups	TRUE	-	Uint8
27-94	Cascade System Status	0 N/A	All set-ups	TRUE	0	VisStr[25]
27-95	Advanced Cascade Relay Output [bin]	0 N/A	All set-ups	TRUE	0	Uint16
27-96	Extended Cascade Relay Output [bin]	0 N/A	All set-ups	TRUE	0	Uint16

Table 6.44



6.4.24 29-** Water Application Functions

Par. No. #	Parameter description	Default value	4-set-up	Change during operation	Conversion index	Type
29-0* Pipe Fill						
29-00	Pipe Fill Enable	[0] Disabled	2 set-ups	FALSE	-	Uint8
29-01	Pipe Fill Speed [RPM]	ExpressionLimit	All set-ups	TRUE	67	Uint16
29-02	Pipe Fill Speed [Hz]	ExpressionLimit	All set-ups	TRUE	-1	Uint16
29-03	Pipe Fill Time	0.00 s	All set-ups	TRUE	-2	Uint32
29-04	Pipe Fill Rate	0.001 ProcessCtrlUnit	All set-ups	TRUE	-3	Int32
29-05	Filled Setpoint	0.000 ProcessCtrlUnit	All set-ups	TRUE	-3	Int32
29-06	No-Flow Disable Timer	0.00 s	All set-ups	TRUE	-2	Uint16
29-1* Deragging Function						
29-10	Derag Cycles	ExpressionLimit	2 set-ups	FALSE	0	Uint32
29-11	Derag at Start/Stop	[0] Off	1 set-up	TRUE	-	Uint8
29-12	Deragging Run Time	0 s	All set-ups	TRUE	0	Uint16
29-13	Derag Speed [RPM]	ExpressionLimit	All set-ups	TRUE	67	Uint16
29-14	Derag Speed [Hz]	ExpressionLimit	All set-ups	TRUE	-1	Uint16
29-15	Derag Off Delay	10 s	All set-ups	TRUE	0	Uint16
29-2* Derag Power Tuning						
29-20	Derag Power[kW]	0.00 kW	All set-ups	TRUE	1	Uint32
29-21	Derag Power[HP]	0.00 hp	All set-ups	TRUE	-2	Uint32
29-22	Derag Power Factor	200 %	All set-ups	TRUE	0	Uint16
29-23	Derag Power Delay	601 s	All set-ups	TRUE	0	Uint16
29-24	Low Speed [RPM]	ExpressionLimit	All set-ups	TRUE	67	Uint16
29-25	Low Speed [Hz]	ExpressionLimit	All set-ups	TRUE	-1	Uint16
29-26	Low Speed Power [kW]	ExpressionLimit	All set-ups	TRUE	1	Uint32
29-27	Low Speed Power [HP]	ExpressionLimit	All set-ups	TRUE	-2	Uint32
29-28	High Speed [RPM]	ExpressionLimit	All set-ups	TRUE	67	Uint16
29-29	High Speed [Hz]	ExpressionLimit	All set-ups	TRUE	-1	Uint16
29-30	High Speed Power [kW]	ExpressionLimit	All set-ups	TRUE	1	Uint32
29-31	High Speed Power [HP]	ExpressionLimit	All set-ups	TRUE	-2	Uint32
29-32	Derag On Ref Bandwidth	5 %	All set-ups	TRUE	0	Uint8

Table 6.45



6.4.25 31-** Bypass Option

Par. No. #	Parameter description	Default value	4-set-up	Change during operation	Conversion index	Type
31-00	Bypass Mode	[0] Drive	All set-ups	TRUE	-	Uint8
31-01	Bypass Start Time Delay	30 s	All set-ups	TRUE	0	Uint16
31-02	Bypass Trip Time Delay	0 s	All set-ups	TRUE	0	Uint16
31-03	Test Mode Activation	[0] Disabled	All set-ups	TRUE	-	Uint8
31-10	Bypass Status Word	0 N/A	All set-ups	FALSE	0	V2
31-11	Bypass Running Hours	0 h	All set-ups	FALSE	74	Uint32
31-19	Remote Bypass Activation	[0] Disabled	2 set-ups	TRUE	-	Uint8

Table 6.46

6

6.5 Parameter Options - Filter

6.5.1 0-** Operation/Display

Par. No. #	Parameter description	Default value	4-set-up	Change during operation	Conversion index	Type
0-0* Basic Settings						
0-01	Language	[0] English	1 set-up	TRUE	-	Uint8
0-04	Operating State at Power-up (Hand)	[1] Forced stop	All set-ups	TRUE	-	Uint8
0-1* Set-up Operations						
0-10	Active Set-up	[1] Set-up 1	1 set-up	TRUE	-	Uint8
0-11	Edit Set-up	[1] Set-up 1	All set-ups	TRUE	-	Uint8
0-12	This Set-up Linked to	[0] Not linked	All set-ups	FALSE	-	Uint8
0-13	Readout: Linked Set-ups	0 N/A	All set-ups	FALSE	0	Uint16
0-14	Readout: Edit Set-ups / Channel	0 N/A	All set-ups	TRUE	0	Int32
0-2* LCP Display						
0-20	Display Line 1.1 Small	30112	All set-ups	TRUE	-	Uint16
0-21	Display Line 1.2 Small	30110	All set-ups	TRUE	-	Uint16
0-22	Display Line 1.3 Small	30120	All set-ups	TRUE	-	Uint16
0-23	Display Line 2 Large	30100	All set-ups	TRUE	-	Uint16
0-24	Display Line 3 Large	30121	All set-ups	TRUE	-	Uint16
0-25	My Personal Menu	ExpressionLimit	1 set-up	TRUE	0	Uint16
0-4* LCP Keypad						
0-40	[Hand on] Key on LCP	[1] Enabled	All set-ups	TRUE	-	Uint8
0-41	[Off] Key on LCP	[1] Enabled	All set-ups	TRUE	-	Uint8
0-42	[Auto on] Key on LCP	[1] Enabled	All set-ups	TRUE	-	Uint8
0-43	[Reset] Key on LCP	[1] Enabled	All set-ups	TRUE	-	Uint8
0-5* Copy/Save						
0-50	LCP Copy	[0] No copy	All set-ups	FALSE	-	Uint8
0-51	Set-up Copy	[0] No copy	All set-ups	FALSE	-	Uint8
0-6* Password						
0-60	Main Menu Password	100 N/A	1 set-up	TRUE	0	Int16
0-61	Access to Main Menu w/o Password	[0] Full access	1 set-up	TRUE	-	Uint8
0-65	Quick Menu Password	200 N/A	1 set-up	TRUE	0	Int16
0-66	Access to Quick Menu w/o Password	[0] Full access	1 set-up	TRUE	-	Uint8

Table 6.47



6.5.2 5-** Digital In/Out

Par. No. #	Parameter description	Default value	4-set-up	Change during operation	Conversion index	Type
5-0* Digital I/O mode						
5-00	Digital I/O Mode	[0] PNP	All set-ups	FALSE	-	Uint8
5-01	Terminal 27 Mode	[0] Input	All set-ups	TRUE	-	Uint8
5-02	Terminal 29 Mode	[0] Input	All set-ups	TRUE	-	Uint8
5-1* Digital Inputs						
5-10	Terminal 18 Digital Input	[8] Start	All set-ups	TRUE	-	Uint8
5-11	Terminal 19 Digital Input	[0] No operation	All set-ups	TRUE	-	Uint8
5-12	Terminal 27 Digital Input	[0] No operation	All set-ups	TRUE	-	Uint8
5-13	Terminal 29 Digital Input	[0] No operation	All set-ups	TRUE	-	Uint8
5-14	Terminal 32 Digital Input	[90] AC Contactor	All set-ups	TRUE	-	Uint8
5-15	Terminal 33 Digital Input	[91] DC Contactor	All set-ups	TRUE	-	Uint8
5-16	Terminal X30/2 Digital Input	[0] No operation	All set-ups	TRUE	-	Uint8
5-17	Terminal X30/3 Digital Input	[0] No operation	All set-ups	TRUE	-	Uint8
5-18	Terminal X30/4 Digital Input	[0] No operation	All set-ups	TRUE	-	Uint8
5-19	Terminal 37 Safe Stop	[1] Safe Stop Alarm	1 set-up	TRUE	-	Uint8
5-3* Digital Outputs						
5-30	Terminal 27 Digital Output	[0] No operation	All set-ups	TRUE	-	Uint8
5-31	Terminal 29 Digital Output	[0] No operation	All set-ups	TRUE	-	Uint8
5-4* Relays						
5-40	Function Relay	[0] No operation	All set-ups	TRUE	-	Uint8
5-41	On Delay, Relay	0.30 s	All set-ups	TRUE	-2	Uint16
5-42	Off Delay, Relay	0.30 s	All set-ups	TRUE	-2	Uint16

Table 6.48

6.5.3 8-** Comm. and Options

Par. No. #	Parameter description	Default value	4-set-up	Change during operation	Conversion index	Type
8-0* General Settings						
8-01	Control Site	[0] Digital and ctrl.word	All set-ups	TRUE	-	Uint8
8-02	Control Word Source	null	All set-ups	TRUE	-	Uint8
8-03	Control Word Timeout Time	1.0 s	1 set-up	TRUE	-1	Uint32
8-04	Control Word Timeout Function	[0] Off	1 set-up	TRUE	-	Uint8
8-05	End-of-Timeout Function	[1] Resume set-up	1 set-up	TRUE	-	Uint8
8-06	Reset Control Word Timeout	[0] Do not reset	All set-ups	TRUE	-	Uint8
8-3* FC Port Settings						
8-30	Protocol	[1] FC MC	1 set-up	TRUE	-	Uint8
8-31	Address	2 N/A	1 set-up	TRUE	0	Uint8
8-32	FC Port Baud Rate	[2] 9600 Baud	1 set-up	TRUE	-	Uint8
8-35	Minimum Response Delay	10 ms	All set-ups	TRUE	-3	Uint16
8-36	Max Response Delay	5000 ms	1 set-up	TRUE	-3	Uint16
8-37	Max Inter-Char Delay	25 ms	1 set-up	TRUE	-3	Uint16
8-5* Digital/Bus						
8-53	Start Select	[3] Logic OR	All set-ups	TRUE	-	Uint8
8-55	Set-up Select	[3] Logic OR	All set-ups	TRUE	-	Uint8

Table 6.49



6.5.4 14-** Special Functions

Par. No. #	Parameter description	Default value	4-set-up	Change during operation	Conversion index	Type
14-2* Trip Reset						
14-20	Reset Mode	[0] Manual reset	All set-ups	TRUE	-	Uint8
14-21	Automatic Restart Time	10 s	All set-ups	TRUE	0	Uint16
14-22	Operation Mode	[0] Normal operation	All set-ups	TRUE	-	Uint8
14-23	Typecode Setting	null	2 set-ups	FALSE	-	Uint8
14-28	Production Settings	[0] No action	All set-ups	TRUE	-	Uint8
14-29	Service Code	0 N/A	All set-ups	TRUE	0	Int32
14-5* Environment						
14-50	RFI Filter	[1] On	1 set-up	FALSE	-	Uint8
14-53	Fan Monitor	[1] Warning	All set-ups	TRUE	-	Uint8
14-54	Bus Partner	1 N/A	2 set-ups	TRUE	0	Uint16

Table 6.50

6.5.5 15-** FC Information

Par. No. #	Parameter description	Default value	4-set-up	Change during operation	Conversion index	Type
15-0* Operating Data						
15-00	Operating Hours	0 h	All set-ups	FALSE	74	Uint32
15-01	Running Hours	0 h	All set-ups	FALSE	74	Uint32
15-03	Power Up's	0 N/A	All set-ups	FALSE	0	Uint32
15-04	Over Temp's	0 N/A	All set-ups	FALSE	0	Uint16
15-05	Over Volt's	0 N/A	All set-ups	FALSE	0	Uint16
15-07	Reset Running Hours Counter	[0] Do not reset	All set-ups	TRUE	-	Uint8
15-1* Data Log Settings						
15-10	Logging Source	0	2 set-ups	TRUE	-	Uint16
15-11	Logging Interval	ExpressionLimit	2 set-ups	TRUE	-3	TimD
15-12	Trigger Event	[0] False	1 set-up	TRUE	-	Uint8
15-13	Logging Mode	[0] Log always	2 set-ups	TRUE	-	Uint8
15-14	Samples Before Trigger	50 N/A	2 set-ups	TRUE	0	Uint8
15-2* Historic Log						
15-20	Historic Log: Event	0 N/A	All set-ups	FALSE	0	Uint8
15-21	Historic Log: Value	0 N/A	All set-ups	FALSE	0	Uint32
15-22	Historic Log: Time	0 ms	All set-ups	FALSE	-3	Uint32
15-3* Fault Log						
15-30	Fault Log: Error Code	0 N/A	All set-ups	FALSE	0	Uint16
15-31	Fault Log: Value	0 N/A	All set-ups	FALSE	0	Int16
15-32	Fault Log: Time	0 s	All set-ups	FALSE	0	Uint32
15-4* Unit Identification						
15-40	FC Type	0 N/A	All set-ups	FALSE	0	VisStr[6]
15-41	Power Section	0 N/A	All set-ups	FALSE	0	VisStr[20]
15-42	Voltage	0 N/A	All set-ups	FALSE	0	VisStr[20]
15-43	Software Version	0 N/A	All set-ups	FALSE	0	VisStr[5]
15-44	Ordered Typecode String	0 N/A	All set-ups	FALSE	0	VisStr[40]
15-45	Actual Typecode String	0 N/A	All set-ups	FALSE	0	VisStr[40]
15-46	Unit Ordering No	0 N/A	All set-ups	FALSE	0	VisStr[8]
15-47	Power Card Ordering No	0 N/A	All set-ups	FALSE	0	VisStr[8]



Par. No. #	Parameter description	Default value	4-set-up	Change during operation	Conversion index	Type
15-48	LCP Id No	0 N/A	All set-ups	FALSE	0	VisStr[20]
15-49	SW ID Control Card	0 N/A	All set-ups	FALSE	0	VisStr[20]
15-50	SW ID Power Card	0 N/A	All set-ups	FALSE	0	VisStr[20]
15-51	Unit Serial Number	0 N/A	All set-ups	FALSE	0	VisStr[10]
15-53	Power Card Serial Number	0 N/A	All set-ups	FALSE	0	VisStr[19]
15-6* Option Ident						
15-60	Option Mounted	0 N/A	All set-ups	FALSE	0	VisStr[30]
15-61	Option SW Version	0 N/A	All set-ups	FALSE	0	VisStr[20]
15-62	Option Ordering No	0 N/A	All set-ups	FALSE	0	VisStr[8]
15-63	Option Serial No	0 N/A	All set-ups	FALSE	0	VisStr[18]
15-70	Option in Slot A	0 N/A	All set-ups	FALSE	0	VisStr[30]
15-71	Slot A Option SW Version	0 N/A	All set-ups	FALSE	0	VisStr[20]
15-72	Option in Slot B	0 N/A	All set-ups	FALSE	0	VisStr[30]
15-73	Slot B Option SW Version	0 N/A	All set-ups	FALSE	0	VisStr[20]
15-74	Option in Slot C0	0 N/A	All set-ups	FALSE	0	VisStr[30]
15-75	Slot C0 Option SW Version	0 N/A	All set-ups	FALSE	0	VisStr[20]
15-76	Option in Slot C1	0 N/A	All set-ups	FALSE	0	VisStr[30]
15-77	Slot C1 Option SW Version	0 N/A	All set-ups	FALSE	0	VisStr[20]
15-9* Parameter Info						
15-92	Defined Parameters	0 N/A	All set-ups	FALSE	0	UInt16
15-93	Modified Parameters	0 N/A	All set-ups	FALSE	0	UInt16
15-98	Unit Identification	0 N/A	All set-ups	FALSE	0	VisStr[40]
15-99	Parameter Metadata	0 N/A	All set-ups	FALSE	0	UInt16

Table 6.51



6.5.6 16-** Data Readouts

6

Par. No. #	Parameter description	Default value	4-set-up	Change during operation	Conversion index	Type
16-0* General Status						
16-00	Control Word	0 N/A	All set-ups	FALSE	0	V2
16-03	Status Word	0 N/A	All set-ups	FALSE	0	V2
16-3* AF Status						
16-30	DC Link Voltage	0 V	All set-ups	FALSE	0	Uint16
16-34	Heatsink Temp.	0 °C	All set-ups	FALSE	100	Uint8
16-35	Inverter Thermal	0 %	All set-ups	FALSE	0	Uint8
16-36	Inv. Nom. Current	ExpressionLimit	All set-ups	FALSE	-2	Uint32
16-37	Inv. Max. Current	ExpressionLimit	All set-ups	FALSE	-2	Uint32
16-39	Control Card Temp.	0 °C	All set-ups	FALSE	100	Uint8
16-40	Logging Buffer Full	[0] No	All set-ups	TRUE	-	Uint8
16-49	Current Fault Source	0 N/A	All set-ups	TRUE	0	Uint8
16-6* Inputs & Outputs						
16-60	Digital Input	0 N/A	All set-ups	FALSE	0	Uint16
16-66	Digital Output [bin]	0 N/A	All set-ups	FALSE	0	Int16
16-71	Relay Output [bin]	0 N/A	All set-ups	FALSE	0	Int16
16-8* Fieldbus & FC Port						
16-80	Fieldbus CTW 1	0 N/A	All set-ups	FALSE	0	V2
16-84	Comm. Option STW	0 N/A	All set-ups	FALSE	0	V2
16-85	FC Port CTW 1	0 N/A	All set-ups	FALSE	0	V2
16-9* Diagnosis Readouts						
16-90	Alarm Word	0 N/A	All set-ups	FALSE	0	Uint32
16-91	Alarm Word 2	0 N/A	All set-ups	FALSE	0	Uint32
16-92	Warning Word	0 N/A	All set-ups	FALSE	0	Uint32
16-93	Warning Word 2	0 N/A	All set-ups	FALSE	0	Uint32
16-94	Ext. Status Word	0 N/A	All set-ups	FALSE	0	Uint32

Table 6.52



6.5.7 300-** AF Settings

NOTE

Except for 300-10 Active Filter Nominal Voltage, it is not recommended to change the settings in this parameter group for the Low Harmonic Drive.

Par. No. #	Parameter description	Default value	4-set-up	Change during operation	Conversion index	Type
300-0* General Settings						
300-00	Harmonic Cancellation Mode	[0] Overall	All set-ups	TRUE	-	UInt8
300-01	Compensation Priority	[0] Harmonics	All set-ups	TRUE	-	UInt8
300-1* Network Settings						
300-10	Active Filter Nominal Voltage	ExpressionLimit	2 set-ups	FALSE	0	UInt32
300-2* CT Settings						
300-20	CT Primary Rating	ExpressionLimit	2 set-ups	FALSE	0	UInt32
300-22	CT Nominal Voltage	342 V	2 set-ups	FALSE	0	UInt32
300-24	CT Sequence	[0] L1, L2, L3	2 set-ups	FALSE	-	UInt8
300-25	CT Polarity	[0] Normal	2 set-ups	FALSE	-	UInt8
300-26	CT Placement	[1] Load Current	2 set-ups	FALSE	-	UInt8
300-29	Start Auto CT Detection	[0] Off	All set-ups	FALSE	-	UInt8
300-3* Compensation						
300-30	Compensation Points	0.0 A	All set-ups	TRUE	-1	UInt32
300-35	Cosphi Reference	0.500 N/A	All set-ups	TRUE	-3	UInt16
300-4* Paralleling						
300-40	Master Follower Selection	[2] Not Paralleled	2 set-ups	FALSE	-	UInt8
300-41	Follower ID	1 N/A	2 set-ups	FALSE	0	UInt32
300-42	Num. of Follower AFs	1 N/A	2 set-ups	FALSE	0	UInt32
300-5* Sleep Mode						
300-50	Enable Sleep Mode	null	2 set-ups	TRUE	-	UInt8
300-51	Sleep Mode Trig Source	[0] Mains current	All set-ups	TRUE	-	UInt8
300-52	Sleep Mode Wake Up Trigger	ExpressionLimit	All set-ups	TRUE	0	UInt32
300-53	Sleep Mode Sleep Trigger	80 %	All set-ups	TRUE	0	UInt32

Table 6.53



6.5.8 301-** AF Readouts

Par. No. #	Parameter description	Default value	4-set-up	Change during operation	Conver- sion index	Type
301-0* Output Currents						
301-00	Output Current [A]	0.00 A	All set-ups	TRUE	-2	Int32
301-01	Output Current [%]	0.0 %	All set-ups	TRUE	-1	Int32
301-1* Unit Performance						
301-10	THD of Current [%]	0.0 %	All set-ups	TRUE	-1	UInt16
301-11	Estimated THD of Voltage [%]	0.0 %	All set-ups			UInt16
301-12	Power Factor	0.00 N/A	All set-ups	TRUE	-2	UInt16
301-13	Cosphi	0.00 N/A	All set-ups	TRUE	-2	Int16
301-14	Leftover Currents	0.0 A	All set-ups	TRUE	-1	UInt32
301-2* Mains Status						
301-20	Mains Current [A]	0 A	All set-ups	TRUE	0	Int32
301-21	Mains Frequency	0 Hz	All set-ups	TRUE	0	UInt8
301-22	Fund. Mains Current [A]	0 A	All set-ups	TRUE	0	Int32

Table 6.54

7 RS-485 Installation and Set-up

RS-485 is a two-wire bus interface compatible with multi-drop network topology, i.e. nodes can be connected as a bus, or via drop cables from a common trunk line. A total of 32 nodes can be connected to one network segment. Repeaters divide network segments.

NOTE

Each repeater functions as a node within the segment in which it is installed. Each node connected within a given network must have a unique node address, across all segments.

Terminate each segment at both ends, using either the termination switch (S801) of the frequency converters or a biased termination resistor network. Always use screened twisted pair (STP) cable for bus cabling, and always follow good common installation practice.

Low-impedance earth connection of the screen at every node is important, including at high frequencies. Thus, connect a large surface of the screen to earth, for example with a cable clamp or a conductive cable gland. It may be necessary to apply potential-equalizing cables to maintain the same earth potential throughout the network - particularly in installations with long cables.

To prevent impedance mismatch, always use the same type of cable throughout the entire network. When connecting a motor to the frequency converters, always use screened motor cable.

Cable:	Screened twisted pair (STP)
Impedance:	120 Ω
Cable length:	Max. 1200 m (including drop lines) Max. 500 m station-to-station

Table 7.1

7.1.1 Network Connection

One or more frequency converters can be connected to a control (or master) using the RS-485 standardised interface. Terminal 68 is connected to the P signal (TX+, RX+), while terminal 69 is connected to the N signal (TX-,RX-).

If more than one frequency converter is connected to a master, use parallel connections.

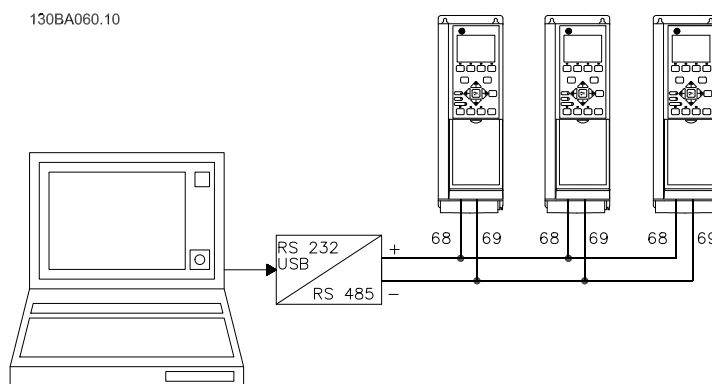

Illustration 7.1

In order to avoid potential equalizing currents in the screen, earth the cable screen via terminal 61, which is connected to the frame via an RC link.

The RS-485 bus must be terminated by a resistor network at both ends. For this purpose, set switch S801 on the control card for "ON".

For more information, see 4.8.2 *Switches S201, S202, and S801*.

7.1.2 EMC Precautions

The following EMC precautions are recommended in order to achieve interference-free operation of the RS-485 network.

Relevant national and local regulations, for example regarding protective earth connection, must be observed. The RS-485 communication cable must be kept away from motor and brake resistor cables to avoid coupling of high frequency noise from one cable to another. Normally a distance of 200 mm (8 inches) is sufficient, but keeping the greatest possible distance between the cables is generally recommended, especially where cables run in parallel over long distances. When crossing is unavoidable, the RS-485 cable must cross motor and brake resistor cables at an angle of 90 degrees.

- A short format of 8 bytes for process data.
- A long format of 16 bytes that also includes a parameter channel.
- A format used for texts.

7.2 Network Configuration

7.2.1 Set-up

Set the following parameters to enable the Drive protocol for the frequency converter.

Parameter Number	Setting
8-30 Protocol	Drive
8-31 Address	1 - 126
8-32 Baud Rate	2400 - 115200
8-33 Parity / Stop Bits	Even parity, 1 stop bit (default)

Table 7.2

7.3 Drive Protocol Message Framing Structure

7.3.1 Content of a Character (byte)

Each character transferred begins with a start bit. Then 8 data bits are transferred, corresponding to a byte. Each character is secured via a parity bit. This bit is set at "1" when it reaches parity. Parity is when there is an equal number of 1s in the 8 data bits and the parity bit in total. A stop bit completes a character, thus consisting of 11 bits in all.

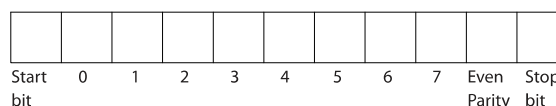

Illustration 7.3

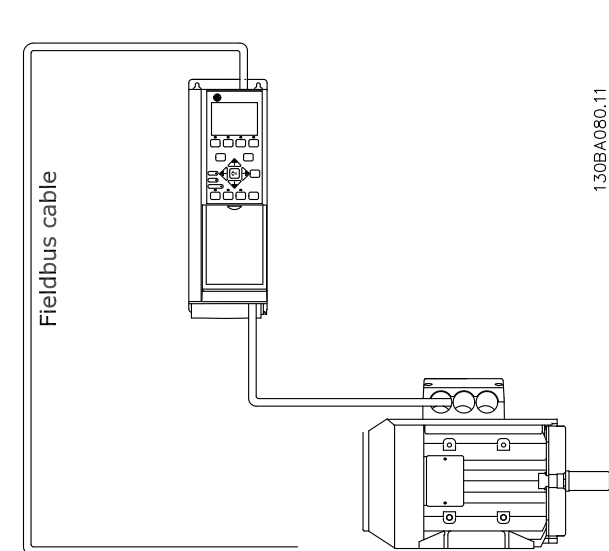

Illustration 7.2

The Drive protocol, also referred to as Drive bus or Standard bus, is the Danfoss standard network. It defines an access technique according to the master-slave principle for communications via a serial bus. One master and a maximum of 126 slaves can be connected to the bus. The master selects the individual slaves via an address character in the telegram. A slave itself can never transmit without first being requested to do so, and direct message transfer between the individual slaves is not possible. Communications occur in the half-duplex mode. The master function cannot be transferred to another node (single-master system).

The physical layer is RS-485, thus utilizing the RS-485 port built into the frequency converter. The Drive protocol supports different telegram formats:

7.3.2 Telegram Structure

Each telegram has the following structure:

1. Start character (STX)=02 Hex
2. A byte denoting the telegram length (LGE)
3. A byte denoting the frequency converter address (ADR)

A number of data bytes (variable, depending on the type of telegram) follows.

A data control byte (BCC) completes the telegram.

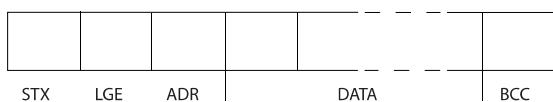

195NA099.10

Illustration 7.4

7.3.3 Telegram Length (LGE)

The telegram length is the number of data bytes plus the address byte ADR and the data control byte BCC.

Data	Length
4 data bytes	LGE = 4 + 1 + 1 = 6 bytes
12 data bytes	LGE = 12 + 1 + 1 = 14 bytes
Messages containing texts	10 ¹ +n bytes

Table 7.3

¹⁾ The 10 represents the fixed characters, while the "n" is variable (depending on the length of the text).

7.3.4 Frequency Converter Address (ADR)

Two different address formats are used. The address range of the frequency converter is either 1-31 or 1-126.

1. Address format 1-31:

- Bit 7 = 0 (address format 1-31 active)
- Bit 6 is not used
- Bit 5 = 1: Broadcast, address bits (0-4) are not used
- Bit 5 = 0: No Broadcast



130BA269.10

Illustration 7.5

Parameter block

The parameter block is used to transfer parameters between master and slave. The data block is made up of 12 bytes (6 words) and also contains the process block.

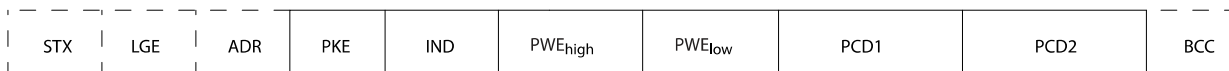

130BA271.10

Illustration 7.6

- Bit 0-4 = frequency converter address 1-31
2. Address format 1-126:

- Bit 7 = 1 (address format 1-126 active)
- Bit 0-6 = frequency converter address 1-126
- Bit 0-6 = 0 Broadcast

The slave returns the address byte unchanged to the master in the response telegram.

7.3.5 Data Control Byte (BCC)

The checksum is calculated as an XOR-function. Before the first byte in the telegram is received, the Calculated Checksum is 0.

7.3.6 The Data Field

The structure of data blocks depends on the type of telegram. There are three telegram types, and the type applies for both control messages (master⇒slave) and response messages (slave⇒master).

The 3 types of telegram are:

Process block (PCD)

The PCD is made up of a data block of 4 bytes (2 words) and contains:

- Control word and reference value (from master to slave)
- Status word and present output frequency (from slave to master)



Text block

The text block is used to read or write texts via the data block.

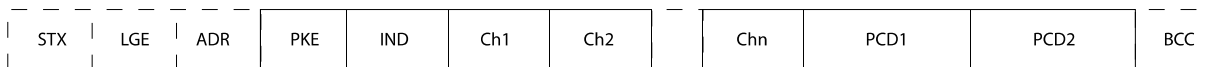

130BA270.10

Illustration 7.7

7.3.7 The PKE Field

The PKE field contains two sub-fields: Parameter command and response AK, and Parameter number PNU:

Bits no. 12-15 transfer parameter commands from master to slave and return processed slave responses to the master.

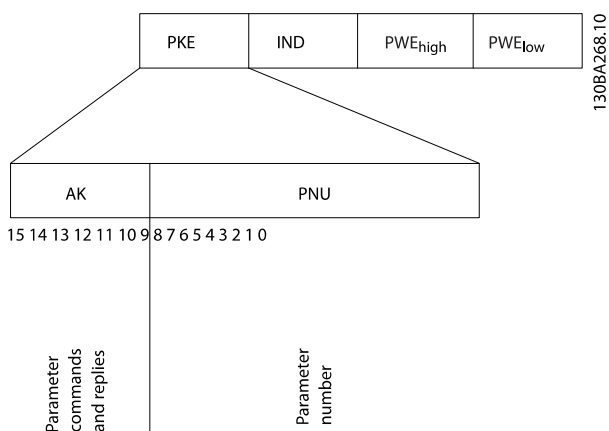

130BA268.10

Illustration 7.8

Parameter commands master ⇒ slave				
Bit no.				Parameter command
15	14	13	12	
0	0	0	0	No command
0	0	0	1	Read parameter value
0	0	1	0	Write parameter value in RAM (word)
0	0	1	1	Write parameter value in RAM (double word)
1	1	0	1	Write parameter value in RAM and EEprom (double word)
1	1	1	0	Write parameter value in RAM and EEprom (word)
1	1	1	1	Read/write text

Table 7.4

Response slave ⇒master				
Bit no.				Response
15	14	13	12	
0	0	0	0	No response
0	0	0	1	Parameter value transferred (word)
0	0	1	0	Parameter value transferred (double word)
0	1	1	1	Command cannot be performed
1	1	1	1	text transferred

Table 7.5



If the command cannot be performed, the slave sends this response:

0111 Command cannot be performed

- and issues the following fault report in the parameter value (PWE):

PWE low (Hex)	Fault Report
0	The parameter number used does not exit
1	There is no write access to the defined parameter
2	Data value exceeds the parameter's limits
3	The sub index used does not exit
4	The parameter is not the array type
5	The data type does not match the defined parameter
11	Data change in the defined parameter is not possible in the frequency converter's present mode. Certain parameters can only be changed when the motor is turned off
82	There is no bus access to the defined parameter
83	Data change is not possible because factory setup is selected

Table 7.6

7.3.8 Parameter Number (PNU)

Bits no. 0-11 transfer parameter numbers. The function of the relevant parameter is defined in the parameter description in the product specific Programming Guide.

7.3.9 Index (IND)

The index is used together with the parameter number to read/write-access parameters with an index, e.g. 15-30 Alarm Log: Error Code. The index consists of 2 bytes, a low byte and a high byte.

Only the low byte is used as an index.

7.3.10 Parameter Value (PWE)

The parameter value block consists of 2 words (4 bytes), and the value depends on the defined command (AK). The master prompts for a parameter value when the PWE block contains no value. To change a parameter value (write), write the new value in the PWE block and send from the master to the slave.

When a slave responds to a parameter request (read command), the present parameter value in the PWE block is transferred and returned to the master. If a parameter contains not a numerical value but several data options, e.g. 0-01 Language where [0] corresponds to English, and [4] corresponds to Spanish, select the data value by entering the value in the PWE block. See Example - Selecting a data value. Serial communication is only capable of reading parameters containing data type 9 (text string).

15-40 FC Type to 15-53 Power Card Serial Number contain data type 9.

For example, read the unit size and mains voltage range in 15-40 FC Type. When a text string is transferred (read), the length of the telegram is variable, and the texts are of different lengths. The telegram length is defined in the second byte of the telegram, LGE. When using text transfer the index character indicates whether it is a read or a write command.

To read a text via the PWE block, set the parameter command (AK) to 'F' Hex. The index character high-byte must be "4".

Some parameters contain text that can be written to via the serial bus. To write a text via the PWE block, set the parameter command (AK) to 'F' Hex. The index characters high-byte must be "5".

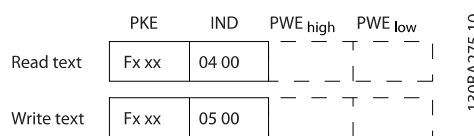

Illustration 7.9

130BA275.10



7.3.11 Data Types Supported by the Frequency Converter

Unsigned means that there is no operational sign in the telegram.

Data types	Description
3	Integer 16
4	Integer 32
5	Unsigned 8
6	Unsigned 16
7	Unsigned 32
9	Text string
10	Byte string
13	Time difference
33	Reserved
35	Bit sequence

Table 7.7

7.3.12 Conversion

The various attributes of each parameter are displayed in the section Factory Settings. Parameter values are transferred as whole numbers only. Conversion factors are therefore used to transfer decimals.

4-12 Motor Speed Low Limit [Hz] has a conversion factor of 0.1.

To preset the minimum frequency to 10 Hz, transfer the value 100. A conversion factor of 0.1 means that the value transferred is multiplied by 0.1. The value 100 is thus perceived as 10.0.

Examples:

0s⇒conversion index 0

0.00s⇒conversion index -2

0ms⇒ conversion index -3

0.00ms⇒conversion index -5

Conversion index	Conversion factor
100	
75	
74	
67	
6	1000000
5	100000
4	10000
3	1000
2	100
1	10
0	1
-1	0.1
-2	0.01
-3	0.001
-4	0.0001
-5	0.00001
-6	0.000001
-7	0.0000001

Table 7.8 Conversion Table

7.3.13 Process Words (PCD)

The block of process words is divided into two blocks of 16 bits, which always occur in the defined sequence.

PCD 1	PCD 2
Control telegram (master⇒ slave Control word)	Reference-value
Control telegram (slave ⇒ master) Status word	Present output frequency

Table 7.9

7.4 Examples

All parameters in the AF-650 GP are named with one or two letters, a "-" and a number e.g. F-07. To access parameters, use the following table because letters cannot be addressed.

Example: F-07 = 7, E-01 = 101, DR-53 = 1253.



Letter	Number
F	0
E	1
C	2
P	3
H	4
K	5
AN	6
B	7
O	8
PB	9
SP	10
XC	11
DR	12
LG	13
CL	14
ID	15
AP	16
T	17
FB	18
PC	19
AO	20
BP	21
DN	22
PI	23
LC	24
EC	25
RS	26
BN	27
LN	28
EN	29
CB	30
CA	31
CD	32

Table 7.10

7.4.1 Writing a Parameter Value

Change 4-14 Motor Speed High Limit [Hz] to 100 Hz.
Write the data in EEPROM.

PKE = E00F Hex - Write single word in 4-14 Motor Speed High Limit [Hz]
 IND = 0000 Hex
 PWEHIGH = 0000 Hex
 PWELOW = 03E8 Hex - Data value 1000, corresponding to 100 Hz, see 7.3.12 Conversion.

The telegram will look like this:

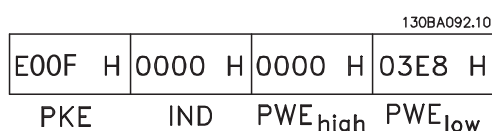

Illustration 7.10

NOTE

4-14 Motor Speed High Limit [Hz] is a single word, and the parameter command for write in EEPROM is "E". 4-14 Motor Speed High Limit [Hz] is 00F in hexadecimal.

The response from the slave to the master will be:

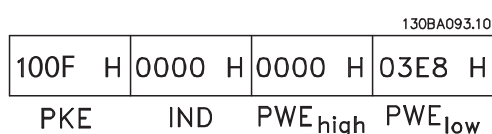

Illustration 7.11

7.4.2 Reading a Parameter Value

Read the value in 3-41 Ramp 1 Ramp Up Time

PKE = 1007 Hex - Read parameter value in 3-41 Ramp 1 Ramp Up Time
 IND = 0000 Hex
 PWEHIGH = 0000 Hex
 PWELOW = 0000 Hex

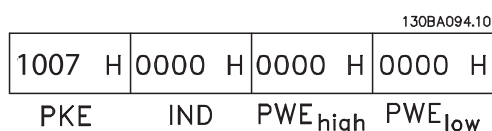

Illustration 7.12

If the value in 3-41 Ramp 1 Ramp Up Time is 10 s, the response from the slave to the master will be:

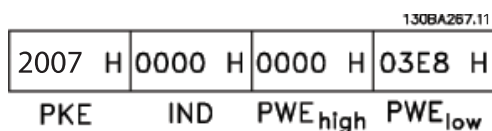

Illustration 7.13

3E8 Hex corresponds to 1000 decimal. The conversion index for 3-41 Ramp 1 Ramp Up Time is -2, i.e. 0.01. 3-41 Ramp 1 Ramp Up Time is of the type Unsigned 32.



sizes range from 1 register (2 characters) up to 10 registers (20 characters).

7.5 How to Access Parameters

7.5.1 Parameter Handling

The PNU (Parameter Number) is translated from the register address contained in the Modbus read or write message. The parameter number is translated to Modbus as (10 x parameter number) DECIMAL.

7.5.2 Storage of Data

The Coil 65 decimal determines whether data written to the telegram are stored in EEPROM and RAM (coil 65 = 1) or only in RAM (coil 65 = 0).

7.5.3 IND

The array index is set in Holding Register 9 and used when accessing array parameters.

7.5.4 Text Blocks

Parameters stored as text strings are accessed in the same way as the other parameters. The maximum text block size is 20 characters. If a read request for a parameter is for more characters than the parameter stores, the response is truncated. If the read request for a parameter is for fewer characters than the parameter stores, the response is space filled.

7.5.5 Conversion Factor

The different attributes for each parameter can be seen in the section on factory settings. Since a parameter value can only be transferred as a whole number, a conversion factor must be used to transfer decimals.

7.5.6 Parameter Values

Standard Data Types

Standard data types are int16, int32, uint8, uint16 and uint32. They are stored as 4x registers (40001 – 4FFFF). The parameters are read using function 03HEX "Read Holding Registers." Parameters are written using the function 6HEX "Preset Single Register" for 1 register (16 bits), and the function 10HEX "Preset Multiple Registers" for 2 registers (32 bits). Readable sizes range from 1 register (16 bits) up to 10 registers (20 characters).

Non standard Data Types

Non standard data types are text strings and are stored as 4x registers (40001 – 4FFFF). The parameters are read using function 03HEX "Read Holding Registers" and written using function 10HEX "Preset Multiple Registers." Readable



8 General Specifications

Mains supply (L1, L2, L3)

Supply voltage 380-480 V +5%

Mains voltage low / mains drop-out:

During low mains voltage or a mains drop-out, the frequency converter continues until the intermediate circuit voltage drops below the minimum stop level, which corresponds typically to 15% below the frequency converter's lowest rated supply voltage. Power-up and full torque cannot be expected at mains voltage lower than 10% below the frequency converter's lowest rated supply voltage.

Supply frequency 50/60 Hz ±5%

Max. imbalance temporary between mains phases 3.0 % of rated supply voltage

True Power Factor (λ) > 0.98 nominal at rated load

Displacement Power Factor ($\cos\phi$) near unity (> 0.98)

THiD < 5%

Switching on input supply L1, L2, L3 (power-ups) maximum once/2 min.

Environment according to EN60664-1 overvoltage category III / pollution degree 2

The unit is suitable for use on a circuit capable of delivering not more than 100.000 RMS symmetrical Amperes, 480/600 V maximum.

Motor output (U, V, W)

Output voltage 0 - 100% of supply voltage

Output frequency 0 - 800* Hz

Switching on output Unlimited

Accel/Decel Times 1 - 3600 s

* Voltage and power dependent

Torque characteristics

Starting torque (Constant torque) maximum 110% for 1 min.*

Starting torque maximum 135% up to 0.5 s*

Overload torque (Constant torque) maximum 110% for 1 min.*

**Percentage relates to AF-600 FP Drive's nominal torque.*

Cable lengths and cross sections

Max. motor cable length, screened/armoured 150 m

Max. motor cable length, unscreened/unarmoured 300 m

Max. cross section to motor, mains and brake *

Maximum cross section to control terminals, rigid wire 1.5 mm²/16 AWG (2 x 0.75 mm²)

Maximum cross section to control terminals, flexible cable 1 mm²/18 AWG

Maximum cross section to control terminals, cable with enclosed core 0.5 mm²/20 AWG

Minimum cross section to control terminals 0.25 mm²

** See 8.1.1 Mains Supply 3x380-480 V AC - High Power for more information!*

Digital inputs

Programmable digital inputs 4 (6)

Terminal number 18, 19, 27¹⁾, 29, 32, 33,

Logic PNP or NPN

Voltage level 0 - 24 V DC

Voltage level, logic '0' PNP < 5 V DC

Voltage level, logic '1' PNP > 10 V DC

Voltage level, logic '0' NPN > 19 V DC

Voltage level, logic '1' NPN < 14 V DC

Maximum voltage on input 28 V DC

Input resistance, R_i approx. 4 k Ω

All digital inputs are galvanically isolated from the supply voltage (PELV) and other high-voltage terminals.

1) Terminals 27 and 29 can also be programmed as output.





General Specifications

VLT® Automation VT Drive FC 322 Drive LHD for AAF006 Operating Instructions

Analog inputs	
Number of analog inputs	2
Terminal number	53, 54
Modes	Voltage or current
Mode select	Switch S201 and switch S202
Voltage mode	Switch S201/switch S202 = OFF (U)
Voltage level	0 to + 10 V (scaleable)
Input resistance, R_i	approx. 10 k Ω
Max. voltage	\pm 20 V
Current mode	Switch S201/switch S202 = ON (I)
Current level	0/4 to 20 mA (scaleable)
Input resistance, R_i	approx. 200 Ω
Max. current	30 mA
Resolution for analog inputs	10 bit (+ sign)
Accuracy of analog inputs	Max. error 0.5% of full scale
Bandwidth	200 Hz

The analog inputs are galvanically isolated from the supply voltage (PELV) and other high-voltage terminals.

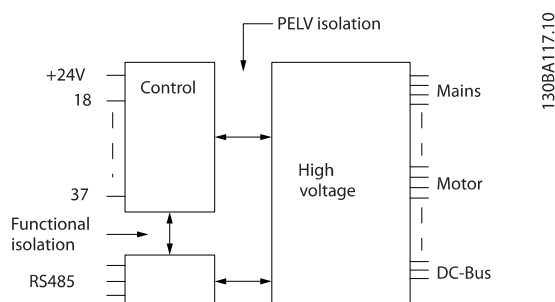

Illustration 8.1

Pulse inputs	
Programmable pulse inputs	2
Terminal number pulse	29, 33
Max. frequency at terminal, 29, 33	110 kHz (Push-pull driven)
Max. frequency at terminal, 29, 33	5 kHz (open collector)
Min. frequency at terminal 29, 33	4 Hz
Voltage level	see section on Digital input
Maximum voltage on input	28 V DC
Input resistance, R_i	approx. 4 k Ω
Pulse input accuracy (0.1-1 kHz)	Max. error: 0.1% of full scale
Analog output	
Number of programmable analog outputs	1
Terminal number	42
Current range at analog output	0/4 - 20 mA
Max. resistor load to common at analog output	500 Ω
Accuracy on analog output	Max. error: 0.8% of full scale
Resolution on analog output	8 bit

The analog output is galvanically isolated from the supply voltage (PELV) and other high-voltage terminals.

Control card, RS-485 serial communication

Terminal number	68 (P,TX+, RX+), 69 (N,TX-, RX-)
Terminal number 61	Common for terminals 68 and 69

The RS-485 serial communication circuit is functionally seated from other central circuits and galvanically isolated from the supply voltage (PELV).

**General Specifications****VLT® Automation VT Drive FC 322 Drive LHD for AAF006 Operating Instructions**

Digital output	
Programmable digital/pulse outputs	2
Terminal number	27, 29 ¹⁾
Voltage level at digital/frequency output	0-24 V
Max. output current (sink or source)	40 mA
Max. load at frequency output	1 kΩ
Max. capacitive load at frequency output	10 nF
Minimum output frequency at frequency output	0 Hz
Maximum output frequency at frequency output	32 kHz
Accuracy of frequency output	Max. error: 0.1% of full scale
Resolution of frequency outputs	12 bit

1) Terminal 27 and 29 can also be programmed as input.

The digital output is galvanically isolated from the supply voltage (PELV) and other high-voltage terminals.

Control card, 24 V DC output

Terminal number	12, 13
Max. load	200 mA

The 24 V DC supply is galvanically isolated from the supply voltage (PELV), but has the same potential as the analog and digital inputs and outputs.

Relay outputs

Programmable relay outputs	
2	
Relay 01 Terminal number	1-3 (break), 1-2 (make)
Max. terminal load (AC-1) ¹⁾ on 1-3 (NC), 1-2 (NO) (Resistive load)	240 V AC, 2 A
Max. terminal load (AC-15) ¹⁾ (Inductive load @ cosφ 0.4)	240 V AC, 0.2 A
Max. terminal load (DC-1) ¹⁾ on 1-2 (NO), 1-3 (NC) (Resistive load)	60 V DC, 1 A
Max. terminal load (DC-13) ¹⁾ (Inductive load)	24 V DC, 0.1 A
Relay 02 Terminal number	4-6 (break), 4-5 (make)
Max. terminal load (AC-1) ¹⁾ on 4-5 (NO) (Resistive load) ²⁾³⁾	400 V AC, 2 A
Max. terminal load (AC-15) ¹⁾ on 4-5 (NO) (Inductive load @ cosφ 0.4)	240 V AC, 0.2 A
Max. terminal load (DC-1) ¹⁾ on 4-5 (NO) (Resistive load)	80 V DC, 2 A
Max. terminal load (DC-13) ¹⁾ on 4-5 (NO) (Inductive load)	24 V DC, 0.1 A
Max. terminal load (AC-1) ¹⁾ on 4-6 (NC) (Resistive load)	240 V AC, 2 A
Max. terminal load (AC-15) ¹⁾ on 4-6 (NC) (Inductive load @ cosφ 0.4)	240 V AC, 0.2 A
Max. terminal load (DC-1) ¹⁾ on 4-6 (NC) (Resistive load)	50 V DC, 2 A
Max. terminal load (DC-13) ¹⁾ on 4-6 (NC) (Inductive load)	24 V DC, 0.1 A
Min. terminal load on 1-3 (NC), 1-2 (NO), 4-6 (NC), 4-5 (NO)	24 V DC 10 mA, 24 V AC 20 mA
Environment according to EN 60664-1	overvoltage category III/pollution degree 2

1) IEC 60947 parts 4 and 5

The relay contacts are galvanically isolated from the rest of the circuit by reinforced isolation (PELV).

2) Overvoltage Category II

3) UL applications 300 V AC 2 A

Control card, 10 V DC output

Terminal number	50
Output voltage	10.5 V ±0.5 V
Max. load	25 mA

The 10 V DC supply is galvanically isolated from the supply voltage (PELV) and other high-voltage terminals.

Control characteristics

Resolution of output frequency at 0æ-æ1000 Hz	+/- 0.003 Hz
System response time (terminals 18, 19, 27, 29, 32, 33)	≤ 2 ms
Speed control range (open loop)	1:100 of synchronous speed
Speed accuracy (open loop)	30æ-æ4000 rpm: Maximum error of ±8 rpm

All control characteristics are based on a 4-pole asynchronous motor



General Specifications

VLT® Automation VT Drive FC 322 Drive LHD for AAF006 Operating Instructions

Surroundings

Enclosure, frame size 4X and 5X	IP21, IP54 (hybrid)
Enclosure, frame size 6X	IP21, IP54 (hybrid)
Vibration test	0.7 g
Relative humidity	5%-95%(IEC 721-3-3; Class 3K3 (non-condensing) during operation
Aggressive environment (IEC 60068-2-43) H ₂ S test	class kD
Test method according to IEC 60068-2-43 H ₂ S (10 days)	
- with derating	max. 55° C ¹⁾
- with full output power, typical EFF2 motors	max. 50° C ¹⁾
- at full continuous drive output current	max. 45° C ¹⁾

¹⁾ For more information on derating see the AF-600 FP, section on Special Conditions.

Minimum ambient temperature during full-scale operation	0° C
Minimum ambient temperature at reduced performance	- 10° C
Temperature during storage/transport	-25 - +65/70° C
Maximum altitude above sea level without derating	1000 m
Maximum altitude above sea level with derating	3000 m

Derating for high altitude, see section on special conditions

EMC standards, Emission	EN 61800-3, EN 61000-6-3/4, EN 55011, IEC 61800-3 EN 61800-3, EN 61000-6-1/2,
EMC standards, Immunity	EN 61000-4-2, EN 61000-4-3, EN 61000-4-4, EN 61000-4-5, EN 61000-4-6

See section on special conditions!

Control card performance

Scan interval	5 ms
Control card, USB serial communication	
USB standard	1.1 (Full speed)
USB plug	USB type B "device" plug

CAUTION

Connection to PC is carried out via a standard host/device USB cable.

The USB connection is galvanically isolated from the supply voltage (PELV) and other high-voltage terminals.

The USB connection is not galvanically isolated from protection earth. Use only isolated laptop/PC as connection to the USB connector on the frequency converter or an isolated USB cable/converter.

Protection and Features:

- Electronic thermal motor protection against overload.
- Temperature monitoring of the heatsink ensures that the frequency converter trips if the temperature reaches a predefined level. An overload temperature cannot be reset until the temperature of the heatsink is below the values stated in the tables on the following pages (Guideline - these temperatures may vary for different power sizes, Unit Sizes, enclosure ratings etc.).
- The frequency converter is protected against short-circuits on motor terminals U, V, W.
- If a mains phase is missing, the frequency converter trips or issues a warning (depending on the load).
- Monitoring of the intermediate circuit voltage ensures that the frequency converter trips if the intermediate circuit voltage is too low or too high.
- The frequency converter is protected against earth faults on motor terminals U, V, W.

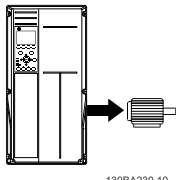
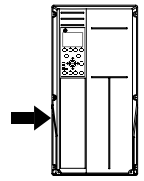

8.1.1 Mains Supply 3x380-480 V AC - High Power

Mains Supply 3x380-480 VAC								
		200 HP		250 HP		300 HP		
Heavy Duty/Light Duty*		HD	LD	HD	LD	HD	LD	
 <p>130BA230.10</p>	Typical Shaft output at 400 V [kW]	132	160	160	200	200	250	
	Typical Shaft output at 460 V [HP]	200	250	250	300	300	350	
	Typical Shaft output at 480 V [kW]	160	200	200	250	250	315	
	IP21/Nema 1 Drive Type	D13		D13		D13		
	IP54/Nema 12 Drive Type	D13		D13		D13		
	Output current							
	Continuous (at 400 V) [A]	260	315	315	395	395	480	
	Intermittent (60 s overload) (at 400 V) [A]	390	347	473	435	593	528	
	Continuous (at 460/ 480 V) [A]	240	302	302	361	361	443	
	Intermittent (60 s overload) (at 460/ 480 V) [A]	360	332	453	397	542	487	
Continuous KVA (at 400 V) [KVA]	180	218	218	274	274	333		
Continuous KVA (at 460 V) [KVA]	191	241	241	288	288	353		
Continuous KVA (at 480 V) [KVA]	208	262	262	313	313	384		
Max. input current								
 <p>130BA229.10</p>	Continuous (at 400 V) [A]	251	304	304	381	381	463	
	Continuous (at 460/ 480 V) [A]	231	291	291	348	348	427	
	Max. cable size, mains motor, brake and load share [mm ² (AWG ²)]	2x185 (2x300 mcm)		2x185 (2x300 mcm)		2x185 (2x300 mcm)		
	Max. external mains fuses [A] ₁	400		500		630		
	Estimated motor power loss at 400 V [W] ⁴	4029		5130		5621		
	Estimated motor power loss at 460 V [W]	3892		4646		5126		
	Estimated filter losses, 400 V	4954		5714		6234		
	Estimated filter losses, 480 V	5279		5819		6681		
	Weight, Unit Size IP21, IP54 [kg]	380		380		406		
	Efficiency ⁴	0.96						
Output frequency	0-800 Hz							
Heatsink overtemp. trip	110° C		110° C		110° C			
Power card ambient trip	60° C							

* Heavy Duty = 160% torque during 60 s, Light Duty = 110% torque during 60 s

Table 8.1



General Specifications

VLT® Automation VT Drive FC 322 Drive LHD for AAF006 Operating Instructions

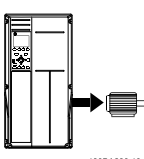
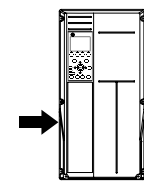
Mains Supply 3x380-480 VAC									
		350 HP		450 HP		500 HP		550 HP	
Heavy Duty/Light Duty*		HD	LD	HD	LD	HD	LD	HD	LD
	Typical Shaft output at 400 V [kW]	250	315	315	355	355	400	400	450
	Typical Shaft output at 460 V [HP]	350	450	450	500	500	600	550	600
	Typical Shaft output at 480 V [kW]	315	355	355	400	400	500	500	530
	IP21/Nema 1 Drive Type	E9		E9		E9		E9	
	IP54/Nema 12 Drive Type	E9		E9		E9		E9	
	Output current								
 130BA230.10	Continuous (at 400 V) [A]	480	600	600	658	658	745	695	800
	Intermittent (60 s overload) (at 400 V) [A]	720	660	900	724	987	820	1043	880
	Continuous (at 460/ 480 V) [A]	443	540	540	590	590	678	678	730
	Intermittent (60 s overload) (at 460/ 480 V) [A]	665	594	810	649	885	746	1017	803
	Continuous KVA (at 400 V) [KVA]	333	416	416	456	456	516	482	554
	Continuous KVA (at 460 V) [KVA]	353	430	430	470	470	540	540	582
	Continuous KVA (at 480 V) [KVA]	384	468	468	511	511	587	587	632
Max. input current									
 130BA229.10	Continuous (at 400 V) [A]	472	590	590	647	647	733	684	787
	Continuous (at 460/ 480 V) [A]	436	531	531	580	580	667	667	718
	Max. cable size, mains, motor and load share [mm ² (AWG ²)]	4x240 (4x500 mcm)		4x240 (4x500 mcm)		4x240 (4x500 mcm)		4x240 (4x500 mcm)	
	Max. cable size, brake [mm ² (AWG ²)]	2x185 (2x350 mcm)		2x185 (2x350 mcm)		2x185 (2x350 mcm)		2x185 (2x350 mcm)	
	Max. external mains fuses [A] ¹	700		900		900		900	
	Estimated motor power loss at 400 V [W] ⁴⁾	6704		7528		8671		9469	
	Estimated motor power loss at 460 V [W]	5930		6724		7820		8527	
	Estimated filter losses, 400 V	6607		7049		7725		8234	
	Estimated filter losses, 460 V	6670		7023		7697		8099	
	Weight, Unit Size IP21, IP54 [kg]	596		623		646		646	
Efficiency ⁴⁾	0.96								
Output frequency	0-600 Hz								
Heatsink overtemp. trip	110° C								
Power card ambient trip	68° C								

* Heavy Duty = 160% torque during 60 s, Light Duty = 110% torque during 60 s

Table 8.2



General Specifications

VLT® Automation VT Drive FC 322 Drive LHD for AAF006 Operating Instructions

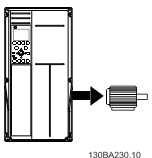
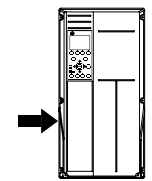
Mains Supply 3x380-480 V AC									
		600 HP		650 HP		750 HP		900 HP	
Heavy Duty/Light Duty*		HD	LD	HD	LD	HD	LD	HD	LD
 130BA230.10	Typical Shaft output at 400 V [kW]	450	500	500	560	560	630	630	710
	Typical Shaft output at 460 V [HP]	600	650	650	750	750	900	900	1000
	Typical Shaft output at 480 V [kW]	530	560	560	630	630	710	710	800
		F18		F18		F18		F18	
	Output current								
	Continuous (at 400 V) [A]	800	880	880	990	990	1120	1120	1260
	Intermittent (60 s overload) (at 400 V) [A]	1200	968	1320	1089	1485	1232	1680	1386
	Continuous (at 460/ 480 V) [A]	730	780	780	890	890	1050	1050	1160
	Intermittent (60 s overload) (at 460/ 480 V) [A]	1095	858	1170	979	1335	1155	1575	1276
	Continuous KVA (at 400 V) [KVA]	554	610	610	686	686	776	776	873
Continuous KVA (at 460 V) [KVA]	582	621	621	709	709	837	837	924	
Continuous KVA (at 480 V) [KVA]	632	675	675	771	771	909	909	1005	
Max. input current									
 130BA229.10	Continuous (at 400 V) [A]	779	857	857	964	964	1090	1090	1227
	Continuous (at 460/ 480 V) [A]	711	759	759	867	867	1022	1022	1129
	Max. cable size, motor [mm ² (AWG ²)]	8x150 (8x300 mcm)							
	Max. cable size, mains 61/62 [mm ² (AWG ²)]	8x240 (8x500 mcm)							
	Max. cable size, mains 63/64 [mm ² (AWG ²)]	8x456 (8x900 mcm)							
	Max. cable size, loadsharing [mm ² (AWG ²)]	4x120 (4x250 mcm)							
	Max. cable size, brake [mm ² (AWG ²)]	4x185 (4x350 mcm)							
	Max. external mains fuses [A] ¹	1600				2000			
	Estimated motor power loss at 400 V [W] ⁴⁾	10647		12338		13201		15436	
	Estimated motor power loss at 460 V [W]	9414		11006		12353		14041	
Max. panel options losses	400								
Weight, Unit Size IP21, IP54 [kg]	2009								
Weight drive section [kg]	1004								
Weight filter section [kg]	1005								
Efficiency ⁴⁾	0.96								
Output frequency	0-600 Hz								
Heatsink overtemp. trip	95° C								
Power card ambient trip	68° C								

* Heavy Duty = 160% torque during 60 s, Light Duty = 110% torque during 60 s

Table 8.3

- 1) For type of fuse see 4.6.12 Fuses.
- 2) American Wire Gauge.

- 3) Measured using 5 m screened motor cables at rated load and rated frequency.



4) The typical power loss is at nominal load conditions and expected to be within +/-15% (tolerance relates to variety in voltage and cable conditions). Values are based on a typical motor efficiency (eff2/eff3 border line). Motors with lower efficiency will also add to the power loss in the frequency converter and opposite. If the switching frequency is increased compared to the default setting, the power losses may rise signifi-

cantly. LCP and typical control card power consumptions are included. Further options and customer load may add up to 30 W to the losses. (Though typical only 4 W extra for a fully loaded control card, or options for slot A or slot B, each). Although measurements are made with state of the art equipment, some measurement inaccuracy must be allowed for (+/-5%).

8.2 Filter Specifications

Frame size	D	E	F	
Voltage [V]	380-480	380-480	380-480	
Current, RMS [A]	120	210	330	Nominal value
Peak Current [A]	340	595	935	Amplitude value of the current
RMS overload [%]	No Overload			60 s in 10 min
Response time [ms]	<0.5			
Settling time - reactive current control [ms]	<40			
Settling time - harmonic current control (filtering) [ms]	<20			
Overshoot - reactive current control [%]	<20			
Overshoot - harmonic current control [%]	<10			

Table 8.4 Power Ranges (LHD with AF)



9 Troubleshooting

9.1 Alarms and Warnings - Frequency Converter (Right LCP)

9.1.1 Warnings/Alarm Messages

A warning or an alarm is signalled by the relevant LED on the front of the frequency converter and indicated by a code on the display.

A warning remains active until its cause is no longer present. Under certain circumstances operation of the motor may still be continued. Warning messages may be critical, but are not necessarily so.

In the event of an alarm, the frequency converter will have tripped. Alarms must be reset to restart operation once their cause has been rectified.

This may be done in three ways:

1. By pressing [Reset].
2. Via a digital input with the "Reset" function.
3. Via serial communication/optional network.

NOTE

After a manual reset pressing [Reset], press [Auto] to restart the motor.

If an alarm cannot be reset, the reason may be that its cause has not been rectified, or the alarm is trip-locked (see also *Table 9.1*).

Alarms that are trip-locked offer additional protection, meaning that the mains supply must be switched off before the alarm can be reset. After being switched back on, the frequency converter is no longer blocked and may be reset as described above once the cause has been rectified.

Alarms that are not trip-locked can also be reset using the automatic reset function in *14-20 Reset Mode*

NOTE

Automatic wake-up is possible!

If a warning and alarm is marked against a code in the table on the following page, this means that either a warning occurs before an alarm, or else that you can specify whether it is a warning or an alarm that is to be displayed for a given fault.

This is possible, for instance, in *1-90 Motor Thermal Protection*. After an alarm or trip, the motor carries on coasting, and the alarm and warning flash. Once the problem has been rectified, only the alarm continues flashing until the frequency converter is reset.

No.	Description	Warning	Alarm/Trip	Alarm/Trip Lock	Parameter Reference
1	10 Volts low	X			
2	Live zero error	(X)	(X)		6-01 Live Zero Timeout Function
3	No motor	(X)			1-80 Function at Stop
4	Mains phase loss	(X)	(X)	(X)	14-12 Function at Mains Imbalance
5	DC link voltage high	X			
6	DC link voltage low	X			
7	DC over-voltage	X	X		
8	DC under voltage	X	X		
9	Inverter overloaded	X	X		
10	Motor Electronic OL over temperature	(X)	(X)		1-90 Motor Thermal Protection
11	Motor thermistor over temperature	(X)	(X)		1-90 Motor Thermal Protection
12	Torque limit	X	X		
13	Over Current	X	X	X	
14	Earth Fault	X	X	X	
15	Hardware mismatch		X	X	
16	Short Circuit		X	X	



Troubleshooting
VLT® Automation VT Drive FC 322 Drive LHD for AAF006 Operating Instructions

No.	Description	Warning	Alarm/Trip	Alarm/Trip Lock	Parameter Reference
17	Control word time-out	(X)	(X)		8-04 Control Timeout Function
20	Temp. Input Error				
21	Param Error				
22	Hoist Mech. Brake	(X)	(X)		Parameter group B-2#
23	Internal Fans	X			
24	External Fans	X			
25	Brake resistor short-circuited	X			
26	Brake resistor power limit	(X)	(X)		2-13 Brake Power Monitoring
27	Brake chopper short-circuited	X	X		
28	Brake check	(X)	(X)		2-15 Brake Check
29	Heatsink temp	X	X	X	
30	Motor phase U missing	(X)	(X)	(X)	4-58 Missing Motor Phase Function
31	Motor phase V missing	(X)	(X)	(X)	4-58 Missing Motor Phase Function
32	Motor phase W missing	(X)	(X)	(X)	4-58 Missing Motor Phase Function
33	Inrush Fault		X	X	
34	Network communication fault	X	X		
35	Option Fault				
36	Mains failure	X	X		
37	Phase imbalance		X		
38	Internal Fault		X	X	
39	Heatsink sensor		X	X	
40	Overload of Digital Output Terminal 27	(X)			5-00 Digital I/O Mode, 5-01 Terminal 27 Mode
41	Overload of Digital Output Terminal 29	(X)			5-00 Digital I/O Mode, 5-02 Terminal 29 Mode
42	Ovrlid X30/6-7	(X)			
43	Ext. Supply (option)				
45	Earth Fault 2	X	X	X	
46	Pwr. card supply		X	X	
47	24 V supply low	X	X	X	
48	1.8 V supply low		X	X	
49	Speed limit	X			
50	Auto Tune calibration failed		X		
51	Auto Tune check U_{nom} and I_{nom}		X		
52	Auto Tune low I_{nom}		X		
53	Auto Tune motor too big		X		
54	Auto Tune motor too small		X		
55	Auto Tune parameter out of range		X		
56	Auto Tune interrupted by user		X		
57	Auto Tune time-out		X		
58	Auto Tune internal fault	X	X		
59	Current limit	X			
60	External Interlock	X	X		
61	Feedback Error	(X)	(X)		4-30 Motor Feedback Loss Function
62	Output Frequency at Maximum Limit	X			



Troubleshooting

VLT® Automation VT Drive FC 322 Drive LHD for AAF006 Operating Instructions

No.	Description	Warning	Alarm/Trip	Alarm/Trip Lock	Parameter Reference
63	Mechanical Brake Low		(X)		2-20 Release Brake Current
64	Voltage Limit	X			
65	Control Board Over-temperature	X	X	X	
66	Heat sink Temperature Low	X			
67	Option Module Configuration has Changed		X		
68	Safe Stop	(X)	(X) ¹⁾		5-19 Terminal 37 Digital Input
69	Pwr. Card Temp		X	X	
70	Illegal Drive configuration			X	
77	Reduced power mode	X			14-59 Actual Number of Inverter Units
78	Tracking Error	(X)	(X)		4-34 Tracking Error Function
79	Illegal PS config		X	X	
80	Drive Restored to Factory Settings		X		
89	Mechanical Brake Sliding	X			
90	Feedback Monitor	(X)	(X)		17-61 Feedback Signal Monitoring
91	Analog input 54 wrong settings			X	S202
243	Brake IGBT	X	X	X	
244	Heatsink temp	X	X	X	
245	Heatsink sensor		X	X	
246	Pwr.card supply			X	
247	Pwr.card temp		X	X	
248	Illegal PS config			X	
249	Rect. low temp.	X			
250	New spare parts			X	
251	New Model number		X	X	

Table 9.1 Alarm/Warning code list

(X) Dependent on parameter

1) Can not be Auto reset via 14-20 Reset Mode

A trip is the action when an alarm has appeared. The trip will coast the motor and can be reset by pressing [Reset] or make a reset by a digital input (parameter group E-1# [1]). The origin event that caused an alarm cannot damage the frequency converter or cause dangerous conditions. A trip lock is an action when an alarm occurs, which may cause damage to the frequency converter or connected

parts. A Trip Lock situation can only be reset by a power cycling.

LED indication	
Warning	yellow
Alarm	flashing red
Trip locked	yellow and red

Table 9.2

Bit	Hex	Dec	Alarm Word	Alarm Word 2	Warning Word	Warning Word 2	Extended Status Word
Alarm Word Extended Status Word							
0	00000001	1	Brake Check (A28)	ServiceTrip, Read/Write	Brake Check (W28)	reserved	Ramping
1	00000002	2	Pwr. Card Temp (A69)	ServiceTrip, (reserved)	Pwr. Card Temp (W69)	reserved	Auto Tune Running
2	00000004	4	Earth Fault (A14)	ServiceTrip, Typecode/ Sparepart	Earth Fault (W14)	reserved	Start CW/CCW

Troubleshooting
VLT® Automation VT Drive FC 322 Drive LHD for AAF006 Operating Instructions

Bit	Hex	Dec	Alarm Word	Alarm Word 2	Warning Word	Warning Word 2	Extended Status Word
3	00000008	8	Ctrl.Card Temp (A65)	ServiceTrip, (reserved)	Ctrl.Card Temp (W65)	reserved	Slow Down
4	00000010	16	Ctrl. Word TO (A17)	ServiceTrip, (reserved)	Ctrl. Word TO (W17)		Catch Up
5	00000020	32	Over Current (A13)	reserved	Over Current (W13)	reserved	Feedback High
6	00000040	64	Torque Limit (A12)	reserved	Torque Limit (W12)	reserved	Feedback Low
7	00000080	128	Motor Th Over (A11)	reserved	Motor Th Over (W11)	reserved	Output Current High
8	00000100	256	Motor Electronic OL Over (A10)	reserved	Motor Electronic OL Over (W10)	reserved	Output Current Low
9	00000200	512	Drive Overld. (A9)	reserved	Drive Overld (W9)	reserved	Output Freq High
10	00000400	1024	DC under Volt (A8)	reserved	DC under Volt (W8)		Output Freq Low
11	00000800	2048	DC over Volt (A7)	reserved	DC over Volt (W7)		Brake Check OK
12	00001000	4096	Short Circuit (A16)	reserved	DC Voltage Low (W6)	reserved	Braking Max
13	00002000	8192	Inrush Fault (A33)	reserved	DC Voltage High (W5)		Braking
14	00004000	16384	Mains ph. Loss (A4)	reserved	Mains ph. Loss (W4)		Out of Speed Range
15	00008000	32768	Auto Tune Not OK	reserved	No Motor (W3)		OVC Active
16	00010000	65536	Live Zero Error (A2)	reserved	Live Zero Error (W2)		AC Brake
17	00020000	131072	Internal Fault (A38)	KTY error	10V Low (W1)	KTY Warn	Password Timelock
18	00040000	262144	Brake Overload (A26)	Fans error	Brake Overload (W26)	Fans Warn	Password Protection
19	00080000	524288	U phase Loss (A30)	ECB error	Brake Resistor (W25)	ECB Warn	
20	00100000	1048576	V phase Loss (A31)	reserved	Brake IGBT (W27)	reserved	
21	00200000	2097152	W phase Loss (A32)	reserved	Speed Limit (W49)	reserved	
22	00400000	4194304	Network Fault (A34)	reserved	Network Fault (W34)	reserved	Unused
23	00800000	8388608	24 V Supply Low (A47)	reserved	24V Supply Low (W47)	reserved	Unused
24	01000000	16777216	Mains Failure (A36)	reserved	Mains Failure (W36)	reserved	Unused
25	02000000	33554432	1.8V Supply Low (A48)	reserved	Current Limit (W59)	reserved	Unused
26	04000000	67108864	Brake Resistor (A25)	reserved	Low Temp (W66)	reserved	Unused
27	08000000	134217728	Brake IGBT (A27)	reserved	Voltage Limit (W64)	reserved	Unused
28	10000000	268435456	Option Change (A67)	reserved	Encoder loss (W90)	reserved	Unused
29	20000000	536870912	Drive Restored to factory settings(A80)	Feedback Fault (A61, A90)	Feedback Fault (W61, W90)		Unused
30	40000000	1073741824	Safe Stop (A68)	Safe Stop (A71)	Safe Stop (W68)	Safe Stop (W71)	Unused



Bit	Hex	Dec	Alarm Word	Alarm Word 2	Warning Word	Warning Word 2	Extended Status Word
31	80000000	2147483648	Mech. brake low (A63)	Dangerous Failure (A72)	Extended Status Word		Unused

Table 9.3 Description of Alarm Word, Warning Word and Extended Status Word

The alarm words, warning words and extended status words can be read out via serial bus or optional network for diagnose. See also *16-94 Ext. Status Word*.



9.1.2 Warnings/Alarm Messages - Frequency Converters

WARNING 1, 10 volts low

The control card voltage is below 10 V from terminal 50. Remove some of the load from terminal 50, as the 10 V supply is overloaded. Max. 15 mA or minimum 590 Ω.

This condition can be caused by a short in a connected potentiometer or improper wiring of the potentiometer.

Troubleshooting: Remove the wiring from terminal 50. If the warning clears, the problem is with the customer wiring. If the warning does not clear, replace the control card.

WARNING/ALARM 2, Live zero error

This warning or alarm will only appear if programmed by the user in *6-01 Live Zero Timeout Function*. The signal on one of the analog inputs is less than 50% of the minimum value programmed for that input. This condition can be caused by broken wiring or faulty device sending the signal.

WARNING/ALARM 3, No motor

No motor has been connected to the output of the frequency converter. This warning or alarm will only appear if programmed by the user in *1-80 Function at Stop*.

Troubleshooting: Check the connection between the drive and the motor.

WARNING/ALARM 4, Mains phase loss

A phase is missing on the supply side, or the mains voltage imbalance is too high. This message also appears for a fault in the input rectifier on the frequency converter. Options are programmed at *14-12 Function at Mains Imbalance*.

Troubleshooting: Check the supply voltage and supply currents to the frequency converter

WARNING 5, DC link voltage high

The intermediate circuit voltage (DC) is higher than the high voltage warning limit. The limit is dependent on the drive voltage rating. The frequency converter is still active.

WARNING 6, DC link voltage low

The intermediate circuit voltage (DC) is lower than the low voltage warning limit. The limit is dependent on the drive voltage rating. The frequency converter is still active.

WARNING/ALARM 7, DC overvoltage

If the intermediate circuit voltage exceeds the limit, the frequency converter trips after a time.

Troubleshooting:

- Connect a brake resistor
- Extend the ramp time
- Change the ramp type
- Activate functions in *2-10 Brake Function*
- Increase *14-26 Trip Delay at Inverter Fault*

WARNING/ALARM 8, DC under voltage

If the intermediate circuit voltage (DC) drops below the under voltage limit, the frequency converter checks if a 24 V backup supply is connected. If no 24 V backup supply is connected, the frequency converter trips after a fixed time delay. The time delay varies with unit size.

WARNING/ALARM 9, Inverter overloaded

The frequency converter is about to cut out because of an overload (too high current for too long). The counter for electronic, thermal inverter protection gives a warning at 98% and trips at 100%, while giving an alarm. The frequency converter *cannot* be reset until the counter is below 90%.

The fault is that the frequency converter is overloaded by more than 100% for too long. Note: See the derating section in the Design Guide for more details if a high switching frequency is required.

WARNING/ALARM 10, Motor overload temperature

According to the electronic thermal protection, the motor is too hot. Select whether the frequency converter gives a warning or an alarm when the counter reaches 100% in *1-90 Motor Thermal Protection*. The fault is that the motor is overloaded by more than 100% for too long.

Troubleshooting:

Check if motor is over heating.

If the motor is mechanically overloaded

That the motor *1-24 Motor Current* is set correctly.

Motor data in *1-20 Motor Power [kW]* through *1-25 Motor Nominal Speed* are set correctly.

The setting in *1-91 Motor External Fan*.

Run Auto Tune in *1-29 Automatic Motor Adaptation (AMA)*.

WARNING/ALARM 11, Motor thermistor over temp

The thermistor or the thermistor connection is disconnected. Select whether the frequency converter gives a warning or an alarm when the counter reaches 100% in *1-90 Motor Thermal Protection*.

Troubleshooting:

Check if motor is over heating.

Check if the motor is mechanically overloaded.

Check that the thermistor is connected correctly between terminal 53 or 54 (analog voltage input) and terminal 50 (+10 V supply), or between terminal 18 or 19 (digital input PNP only) and terminal 50.

If a KTY sensor is used, check for correct connection between terminal 54 and 55.

If using a thermal switch or thermistor, check the programming of *1-93 Thermistor Source* matches sensor wiring.



If using a KTY sensor, check the programming of *1-95 KTY Sensor Type*, *1-96 KTY Thermistor Resource*, and *1-97 KTY Threshold level* match sensor wiring.

WARNING/ALARM 12, Torque limit

The torque is higher than the value in *4-16 Torque Limit Motor Mode* (in motor operation) or the torque is higher than the value in *4-17 Torque Limit Generator Mode* (in regenerative operation). *14-25 Trip Delay at Torque Limit* can be used to change this from a warning only condition to a warning followed by an alarm.

WARNING/ALARM 13, Over Current

The inverter peak current limit (approx. 200% of the rated current) is exceeded. The warning lasts about 1.5 s, then the frequency converter trips and issues an alarm. If extended mechanical brake control is selected, trip can be reset externally.

Troubleshooting:

This fault may be caused by shock loading or fast acceleration with high inertia loads.

Turn off the frequency converter. Check if the motor shaft can be turned.

Check that the motor size matches the frequency converter.

Incorrect motor data in *1-20 Motor Power [kW]* through *1-25 Motor Nominal Speed*.

ALARM 14, Earth (ground) fault

There is a discharge from the output phases to earth, either in the cable between the frequency converter and the motor or in the motor itself.

Troubleshooting:

Turn off the frequency converter and remove the earth fault.

Measure the resistance to ground of the motor leads and the motor with a megohmmeter to check for earth faults in the motor.

Perform current sensor test.

ALARM 15, Hardware mismatch

A fitted option is not operational with the present control board hardware or software.

Record the value of the following parameters and contact your Danfoss supplier:

15-40 FC Type

15-41 Power Section

15-42 Voltage

15-43 Software Version

15-45 Actual Typecode String

15-49 SW ID Control Card

15-50 SW ID Power Card

15-60 Option Mounted

15-61 Option SW Version

ALARM 16, Short circuit

There is short-circuiting in the motor or on the motor terminals.

Turn off the frequency converter and remove the short-circuit.

WARNING/ALARM 17, Control word timeout

There is no communication to the frequency converter. The warning will only be active when *8-04 Control Timeout Function* is NOT set to OFF.

If *8-04 Control Timeout Function* is set to *Stop* and *Trip*, a warning appears and the frequency converter decels until it trips, while giving an alarm.

Troubleshooting:

Check connections on the serial communication cable.

Increase *8-03 Control Timeout Time*

Check operation of the communication equipment.

Verify proper installation based on EMC requirements.

WARNING 22, Hoist Mech. Brake:

Report value will show what kind it is.

0 = The torque ref. was not reached before timeout.

1 = There was no brake feedback before timeout.

WARNING 23, Internal fan fault

The fan warning function is an extra protection function that checks if the fan is running / mounted. The fan warning can be disabled in *14-53 Fan Monitor* ([0] Disabled).

For the unit sizes 4X, 5X and 6X, the regulated voltage to the fans is monitored.

Troubleshooting:

Check fan resistance.

Check soft charge fuses.

WARNING 24, External fan fault

The fan warning function is an extra protection function that checks if the fan is running / mounted. The fan warning can be disabled in *14-53 Fan Monitor* ([0] Disabled).

For the unit sizes 4X, 5X and 6X, the regulated voltage to the fans is monitored.

Troubleshooting:

Check fan resistance.

Check soft charge fuses.

WARNING 25, Brake resistor short circuit

The brake resistor is monitored during operation. If it short circuits, the brake function is disconnected and the warning appears. The frequency converter still works, but without the brake function. Turn off the frequency



converter and replace the brake resistor (see *2-15 Brake Check*).

WARNING/ALARM 26, Brake resistor power limit

The power transmitted to the brake resistor is calculated: as a percentage, as a mean value over the last 120 seconds, on the basis of the resistance value of the brake resistor, and the intermediate circuit voltage. The warning is active when the dissipated braking power is higher than 90%. If [2] Trip has been selected in *2-13 Brake Power Monitoring*, the frequency converter cuts out and issues this alarm, when the dissipated braking power is higher than 100%.



There is a risk of substantial power being transmitted to the brake resistor if the brake transistor is short-circuited.

WARNING/ALARM 27, Brake chopper fault

The brake transistor is monitored during operation and if it short-circuits, the brake function disconnects and issues a warning. The frequency converter is still able to run, but since the brake transistor has short-circuited, substantial power is transmitted to the brake resistor, even if it is inactive.

Turn off the frequency converter and remove the brake resistor.

This alarm/ warning could also occur should the brake resistor overheat. Terminal 104 to 106 are available as brake resistor. Klixon inputs, see *4.6.8 Brake Resistor Temperature Switch*.

WARNING/ALARM 28, Brake check failed

Brake resistor fault: the brake resistor is not connected or not working.

Check *2-15 Brake Check*.

ALARM 29, Heatsink temp

The maximum temperature of the heatsink has been exceeded. The temperature fault will not be reset until the temperature falls below a defined heatsink temperature. The trip and reset point are different based on the frequency converter power size.

Troubleshooting:

- Ambient temperature too high.
- Too long motor cable.
- Incorrect clearance above and below the frequency converter.
- Dirty heatsink.
- Blocked air flow around the frequency converter.
- Damaged heatsink fan.

For the unit sizes 4X, 5X and 6X, this alarm is based on the temperature measured by the heatsink sensor mounted inside the IGBT modules. For the unit sizes 6X, this alarm can also be caused by the thermal sensor in the Rectifier module.

Troubleshooting:

- Check fan resistance.
- Check soft charge fuses.
- IGBT thermal sensor.

ALARM 30, Motor phase U missing

Motor phase U between the frequency converter and the motor is missing.

Turn off the frequency converter and check motor phase U.

ALARM 31, Motor phase V missing

Motor phase V between the frequency converter and the motor is missing.

Turn off the frequency converter and check motor phase V.

ALARM 32, Motor phase W missing

Motor phase W between the frequency converter and the motor is missing.

Turn off the frequency converter and check motor phase W.

ALARM 33, Inrush fault

Too many power-ups have occurred within a short time period. Let unit cool to operating temperature.

WARNING/ALARM 34, Network communication fault

The network on the communication option card is not working.

WARNING/ALARM 36, Mains failure

This warning/alarm is only active if the supply voltage to the frequency converter is lost and *14-10 Mains Failure* is NOT set to OFF. Check the fuses to the frequency converter.

ALARM 38, Internal fault

It may be necessary to contact your Danfoss supplier. Some typical alarm messages:

0	Serial port cannot be initialized. Serious hardware failure
256-258	Power EEPROM data is defect or too old
512	Control board EEPROM data is defect or too old
513	Communication time out reading EEPROM data
514	Communication time out reading EEPROM data
515	Application Orientated Control cannot recognize the EEPROM data
516	Cannot write to the EEPROM because a write command is on progress
517	Write command is under time out
518	Failure in the EEPROM
519	Missing or invalid Barcode data in EEPROM
783	Parameter value outside of min/max limits
1024-1279	A cantelegram that has to be sent, couldn't be sent
1281	Digital Signal Processor flash timeout
1282	Power micro software version mismatch



1283	Power EEPROM data version mismatch
1284	Cannot read Digital Signal Processor software version
1299	Option SW in slot A is too old
1300	Option SW in slot B is too old
1301	Option SW in slot C0 is too old
1302	Option SW in slot C1 is too old
1315	Option SW in slot A is not supported (not allowed)
1316	Option SW in slot B is not supported (not allowed)
1317	Option SW in slot C0 is not supported (not allowed)
1318	Option SW in slot C1 is not supported (not allowed)
1379	Option A did not respond when calculating Platform Version.
1380	Option B did not respond when calculating Platform Version.
1381	Option C0 did not respond when calculating Platform Version.
1382	Option C1 did not respond when calculating Platform Version.
1536	An exception in the Application Orientated Control is registered. Debug information written in LCP
1792	DSP watchdog is active. Debugging of power part data Motor Orientated Control data not transferred correctly
2049	Power data restarted
2064-2072	H081x: option in slot x has restarted
2080-2088	H082x: option in slot x has issued a powerup-wait
2096-2104	H083x: option in slot x has issued a legal powerup-wait
2304	Could not read any data from power EEPROM
2305	Missing SW version from power unit
2314	Missing power unit data from power unit
2315	Missing SW version from power unit
2316	Missing io_statepage from power unit
2324	Power card configuration is determined to be incorrect at power up
2325	A power card has stopped communicating while main power is applied
2326	Power card configuration is determined to be incorrect after the delay for power cards to register
2327	Too many power card locations have been registered as present
2330	Power size information between the power cards does not match
2561	No communication from DSP to ATACD
2562	No communication from ATACD to DSP (state running)
2816	Stack overflow Control board module
2817	Scheduler slow tasks
2818	Fast tasks
2819	Parameter thread
2820	LCP Stack overflow
2821	Serial port overflow
2822	USB port overflow

2836	cfListMempool to small
3072-5122	Parameter value is outside its limits
5123	Option in slot A: Hardware incompatible with Control board hardware
5124	Option in slot B: Hardware incompatible with Control board hardware
5125	Option in slot C0: Hardware incompatible with Control board hardware
5126	Option in slot C1: Hardware incompatible with Control board hardware
5376-6231	Out of memory

Table 9.4

ALARM 39, Heatsink sensor

No feedback from the heatsink temperature sensor.

The signal from the IGBT thermal sensor is not available on the power card. The problem could be on the power card, on the gate drive card, or the ribbon cable between the power card and gate drive card.

WARNING 40, Overload of Digital Output Terminal 27

Check the load connected to terminal 27 or remove short-circuit connection. Check 5-00 Digital I/O Mode and 5-01 Terminal 27 Mode.

WARNING 41, Overload of Digital Output Terminal 29

Check the load connected to terminal 29 or remove short-circuit connection. Check 5-00 Digital I/O Mode and 5-02 Terminal 29 Mode.

WARNING 42, Overload of Digital Output on X30/6 or Overload of Digital Output on X30/7

For X30/6, check the load connected to X30/6 or remove short-circuit connection. Check par. E-56 X30/6 Digital Out (OPCGPIO).

For X30/7, check the load connected to X30/7 or remove short-circuit connection. Check par. E-57 Term X30/7 Digital Out (OPCGPIO).

ALARM 46, Power card supply

The supply on the power card is out of range.

There are three power supplies generated by the switch mode power supply (SMPS) on the power card: 24 V, 5 V, ±18 V. When powered with 24 V DC with the OPC24VPS 24 V DC External Supply Module, only the 24 V and 5 V supplies are monitored. When powered with three phase mains voltage, all three supplied are monitored.

WARNING 47, 24 V supply low

The 24 V DC is measured on the control card. The external 24 V DC backup power supply may be overloaded, otherwise contact your Danfoss supplier.

WARNING 48, 1.8 V supply low

The 1.8 V DC supply used on the control card is outside of allowable limits. The power supply is measured on the control card.

**WARNING 49, Speed limit**

The speed is not within the specified range in *4-11 Motor Speed Low Limit [RPM]* and *4-13 Motor Speed High Limit [RPM]*.

ALARM 50, Auto tune calibration failed

Contact your Danfoss supplier.

ALARM 51, Auto tune check Unom and Inom

The setting of motor voltage, motor current, and motor power is presumably wrong. Check the settings.

ALARM 52, Auto tune low Inom

The motor current is too low. Check the settings.

ALARM 53, Auto tune motor too big

The motor is too big for the Auto tune to be carried out.

ALARM 54, Auto tune motor too small

The motor is too small for the Auto tune to be carried out.

ALARM 55, Auto tune parameter out of range

The parameter values found from the motor are outside acceptable range.

ALARM 56, Auto tune interrupted by user

The Auto tune has been interrupted by the user.

ALARM 57, Auto tune timeout

Try to start the Auto tune again a number of times, until the Auto tune is carried out. Note that repeated runs may heat the motor to a level where the resistance R_s and R_r are increased. In most cases, however, this is not critical.

ALARM 58, Auto tune internal fault

Contact your Danfoss supplier.

WARNING 59, Current limit

The current is higher than the value in *4-18 Current Limit*.

WARNING 60, External interlock

External interlock has been activated. To resume normal operation, apply 24 V DC to the terminal programmed for external interlock and reset the frequency converter (via serial communication, digital I/O, or by pressing [Reset]).

WARNING 61, Tracking error

An error has been detected between calculated motor speed and speed measurement from feedback device. The function for Warning/Alarm/Disable is set in *4-30 Motor Feedback Loss Function*, error setting in *4-31 Motor Feedback Speed Error*, and the allowed error time in *4-32 Motor Feedback Loss Timeout*. During a commissioning procedure the function may be effective.

WARNING 62, Output frequency at maximum limit

The output frequency is higher than the value set in *4-19 Max Output Frequency*

WARNING 64, Voltage limit

The load and speed combination demands a motor voltage higher than the actual DC link voltage.

WARNING/ALARM/TRIP 65, Control card over temperature

Control card over temperature: The cutout temperature of the control card is 80° C.

WARNING 66, Heatsink temperature low

This warning is based on the temperature sensor in the IGBT module.

Troubleshooting:**ALARM 67, Option module configuration has changed**

One or more options have either been added or removed since the last power-down.

ALARM 68, Safe stop activated

Safe stop has been activated. To resume normal operation, apply 24 V DC to terminal 37, then send a reset signal (via Bus, Digital I/O, or by pressing [Reset]). See *5-19 Terminal 37 Digital Input*.

ALARM 69, Power card temperature

The temperature sensor on the power card is either too hot or too cold.

Troubleshooting:

Check the operation of the door fans.

Check that the filters for the door fans are not blocked.

Check that the gland plate is properly installed on IP 21 and IP 54 (NEMA 1 and NEMA 12) frequency converters.

ALARM 70, Illegal Drive Configuration

Actual combination of control board and power board is illegal.

WARNING 76, Power Unit Setup

The required number of power units does not match the detected number of active power units.

Troubleshooting:

When replacing a unit size 6X module this will occur if the power specific data in the module power card does not match the rest of the frequency converter. Confirm the spare part and its power card are the correct part number.

WARNING 77, Reduced power mode:

This warning indicates that the frequency converter is operating in reduced power mode (i.e. less than the allowed number of inverter sections). This warning will be generated on power cycle when the frequency converter is set to run with fewer inverters and will remain on.

ALARM 79, Illegal power section configuration

The scaling card is the incorrect part number or not installed. Also MK102 connector on the power card could not be installed.

ALARM 80, Drive Restored to Factory Settings

Parameter settings are restored to factory settings after a manual reset.

ALARM 91, Analog input 54 wrong settings

Switch S202 has to be set in position OFF (voltage input) when a KTY sensor is connected to analog input terminal 54.

**ALARM 243, Brake IGBT**

This alarm is only for unit sizes 6X. It is equivalent to Alarm 27. The report value in the alarm log indicates which power module generated the alarm:

- 1 = left most inverter module.
- 2 = middle inverter module in unit sizes 62 or 64.
- 2 = right inverter module in unit sizes 61 or 63.
- 3 = right inverter module in unit sizes 62 or 64.
- 5 = rectifier module.

ALARM 244, Heatsink temperature

This alarm is only for unit sizes 6X. It is equivalent to Alarm 29. The report value in the alarm log indicates which power module generated the alarm:

- 1 = left most inverter module.
- 2 = middle inverter module in unit sizes 62 or 64.
- 2 = right inverter module in unit sizes 61 or 63.
- 3 = right inverter module in unit sizes 62 or 64.
- 5 = rectifier module.

ALARM 245, Heatsink sensor

This alarm is only for unit sizes 6X. It is equivalent to Alarm 39. The report value in the alarm log indicates which power module generated the alarm:

- 1 = left most inverter module.
- 2 = middle inverter module in unit sizes 62 or 64.
- 2 = right inverter module in unit sizes 61 or 63.
- 3 = right inverter module in unit sizes 62 or 64.
- 5 = rectifier module.

ALARM 246, Power card supply

This alarm is only for unit sizes 6X. It is equivalent to Alarm 46. The report value in the alarm log indicates which power module generated the alarm:

- 1 = left most inverter module.
- 2 = middle inverter module in unit sizes 62 or 64.
- 2 = right inverter module in unit sizes 61 or 63.
- 3 = right inverter module in unit sizes 62 or 64.
- 5 = rectifier module.

ALARM 247, Power card temperature

This alarm is only for unit sizes 6X. It is equivalent to Alarm 69. The report value in the alarm log indicates which power module generated the alarm:

- 1 = left most inverter module.
- 2 = middle inverter module in unit sizes 62 or 64.
- 2 = right inverter module in unit sizes 61 or 63.
- 3 = right inverter module in unit sizes 62 or 64.
- 5 = rectifier module.

ALARM 248, Illegal power section configuration

This alarm is only for unit sizes 6X. It is equivalent to Alarm 79. The report value in the alarm log indicates which power module generated the alarm:

- 1 = left most inverter module.
- 2 = middle inverter module in unit sizes 62 or 64.
- 2 = right inverter module in unit sizes 61 or 63.
- 3 = right inverter module in unit sizes 62 or 64.
- 5 = rectifier module.

ALARM 250, New spare part

The power or switch mode power supply has been exchanged. The frequency converter type code must be restored in the EEPROM. Remember to select 'Save to EEPROM' to complete.

ALARM 251, New model number

The frequency converter has a new model number.

9.2 Alarms and Warnings - Filter (Left LCP)

NOTE

This sections covers warnings and alarms on the filter side LCP. For warning and alarms for the frequency converter, see previous section

A warning or an alarm is signalled by the relevant LED on the front of the filter and indicated by a code on the display.

A warning remains active until its cause is no longer present. Under certain circumstances operation of the unit may still be continued. Warning messages may be critical, but are not necessarily so.

In the event of an alarm, the unit will have tripped. Alarms must be reset to restart operation once their cause has been rectified.

This may be done in four ways:

1. By pressing [Reset].
2. Via a digital input with the "Reset" function.
3. Via serial communication/optional network.
4. By resetting automatically using the [Auto Reset] function. See *14-20 Reset Mode* in the *VLT@Active Filter AAF 00x Operating Instructions, MG90VXYX*.

NOTE

After a manual reset pressing [Reset], [Auto] or [Hand] must be pressed to restart the unit.

If an alarm cannot be reset, the reason may be that its cause has not been rectified, or the alarm is trip-locked (see also *Table 9.5*).



Alarms that are trip-locked offer additional protection, means that the mains supply must be switched off before the alarm can be reset. After being switched back on, the unit is no longer blocked and may be reset as described above once the cause has been rectified.

Alarms that are not trip-locked can also be reset using the automatic reset function in *14-20 Reset Mode* (Warning: automatic wake-up is possible!)

If a warning and alarm is marked against a code in the table on the following page, this means that either a warning occurs before an alarm, or it can be specified whether it is a warning or an alarm that is to be displayed for a given fault.

A trip is the action when an alarm has appeared. The trip will coast the motor and can be reset by pressing [Reset] or make a reset by a digital input (Par. E-1# [1]). The origin event that caused an alarm cannot damage the frequency converter or cause dangerous conditions. A trip lock is an action when an alarm occurs, which may cause damage to frequency converter or connected parts. A Trip Lock situation can only be reset by a power cycling.

LED indication	
Warning	yellow
Alarm	flashing red
Trip locked	yellow and red

Table 9.5

Alarm Word and Extended Status Word					
Bit	Hex	Dec	Alarm Word	Warning Word	Extended Status Word
0	00000001	1	Mains Cont. Fault	Reserved	Reserved
1	00000002	2	Heatsink Temp	Heatsink Temp	Auto CT Running
2	00000004	4	Earth Fault	Earth Fault	Reserved
3	00000008	8	Ctrl.Card Temp	Ctrl.Card Temp	Reserved
4	00000010	16	Ctrl. Word TO	Ctrl. Word TO	Reserved
5	00000020	32	Over Current	Over Current	Reserved
6	00000040	64	SC Cont. Fault	Reserved	Reserved
7	00000080	128	Cap. Over Current	Cap. Over Current	Reserved
8	00000100	256	Cap. Earth Fault	Cap. Earth Fault	Reserved
9	00000200	512	Inverter Overld.	Inverter Overld.	Reserved
10	00000400	1024	DC under Volt	DC under Volt	Reserved
11	00000800	2048	DC over Volt	DC over Volt	Reserved
12	00001000	4096	Short Circuit	DC Voltage Low	Reserved
13	00002000	8192	Inrush Fault	DC Voltage High	Reserved
14	00004000	16384	Mains ph. Loss	Mains ph. Loss	Reserved
15	00008000	32768	Auto CT Error	Reserved	Reserved
16	00010000	65536	Reserved	Reserved	Reserved
17	00020000	131072	Internal Fault	10V Low	Password Time Lock
18	00040000	262144	DC Over Current	DC Over Current	Password Protection
19	00080000	524288	Resistor temp	Resistor temp	Reserved
20	00100000	1048576	Mains Earth Fault	Mains Earth Fault	Reserved
21	00200000	2097152	Switch. Freq. Limit	Reserved	Reserved
22	00400000	4194304	Fieldbus Fault	Fieldbus Fault	Reserved
23	00800000	8388608	24 V Supply Low	24V Supply Low	Reserved
24	01000000	16777216	CT Range	Reserved	Reserved
25	02000000	33554432	1.8V Supply Low	Reserved	Reserved
26	04000000	67108864	Reserved	Low Temp	Reserved
27	08000000	134217728	Auto CT Interrupt	Reserved	Reserved
28	10000000	268435456	Option Change	Reserved	Reserved
29	20000000	536870912	Unit Initialized	Unit Initialized	Reserved
30	40000000	1073741824			Reserved
31	80000000	2147483648	Mains Freq. Limit	Extended Status Word	Reserved

Table 9.6 Description of Alarm Word, Warning Word and Extended Status Word

The alarm words, warning words and extended status words can be read out via serial bus or optional fieldbus

for diagnosis. See also *16-90 Alarm Word*, *16-92 Warning Word* and *16-94 Ext. Status Word*. "Reserved" means that



the bit is not guaranteed to be any particular value.
Reserved bits should not be used for any purpose.



9.2.1 Fault Messages - Active Filter

WARNING 1, 10 volts low

The control card voltage is below 10 V from terminal 50. Remove some of the load from terminal 50, as the 10 V supply is overloaded. Max. 15 mA or minimum 590 Ω.

WARNING/ALARM 2, Live zero error

The signal on terminal 53 or 54 is less than 50% of the value set in parameters 6-10, 6-12, 6-20 or 6-22 respectively.

WARNING/ALARM 4, Mains phase loss

A phase is missing on the supply side, or the mains voltage imbalance is too high.

WARNING 5, DC link voltage high

The intermediate circuit voltage (DC) is higher than the high voltage warning limit. The unit is still active.

WARNING 6, DC link voltage low

The intermediate circuit voltage (DC) is below the under-voltage limit of the control system. The unit is still active.

WARNING/ALARM 7, DC overvoltage

If the intermediate circuit voltage exceeds the limit, the unit trips.

WARNING/ALARM 8, DC under voltage

If the intermediate circuit voltage (DC) drops below the under voltage limit, the filter checks if a 24 V backup supply is connected. If not, the unit trips. Check that the mains voltage matches the nameplate specification.

WARNING/ALARM 13, Over Current

the unit current limit has been exceeded.

ALARM 14, Earth (ground) fault

The sum current of the IGBT CTs does not equal zero. Check if the resistance of any phase to ground has a low value. Make sure to check both before and after mains contactor. Also make sure IGBT current transducers, connection cables, and connectors are ok.

ALARM 15, Incomp. Hardware

A mounted option is not handled by the present Control Card SW/HW.

ALARM 16, Short circuit

There is a short-circuit in the output. Turn off the unit and correct the error.

WARNING/ALARM 17, Control word timeout

There is no communication to the unit. The warning will only be active when *8-04 Control Timeout Function* is NOT set to OFF. Possible correction: Increase *8-03 Control Timeout Time*. Change *8-04 Control Timeout Function*

WARNING 23, Internal fan fault

Internal fans have failed due to defect hardware or fans not mounted.

WARNING 24, External fan fault

External fans have failed due to defect hardware or fans not mounted.

ALARM 29, Heatsink temp

The maximum temperature of the heatsink has been exceeded. The temperature fault will not be reset until the temperature falls below a defined heatsink temperature.

ALARM 33, Inrush fault

Check whether a 24 V external DC supply has been connected.

WARNING/ALARM 34, Network communication fault

The fieldbus on the communication option card is not working.

WARNING/ALARM 35, Option Fault:

Contact your Danfoss supplier.

ALARM 38, Internal fault

Contact your Danfoss supplier.

ALARM 39, Heatsink sensor

No feedback from the heatsink temperature sensor.

WARNING 40, Overload of Digital Output Terminal 27

Check the load connected to terminal 27 or remove short-circuit connection.

WARNING 41, Overload of Digital Output Terminal 29

Check the load connected to terminal 29 or remove short-circuit connection.

WARNING 42, Overload of Digital Output on X30/6 or Overload of Digital Output on X30/7

For X30/6, check the load connected to X30/6 or remove short-circuit connection.

For X30/7, check the load connected to X30/7 or remove short-circuit connection.

WARNING 43, Ext. Supply (option)

The external 24 V DC supply voltage on the option is not valid.

ALARM 46, Power card supply

The supply on the power card is out of range.

WARNING 47, 24 V supply low

Contact your Danfoss supplier.

WARNING 48, 1.8 V supply low

Contact your Danfoss supplier.

WARNING/ALARM/TRIP 65, Control card over temperature

Control card over temperature: The cutout temperature of the control card is 80° C.

WARNING 66, Heatsink temperature low

This warning is based on the temperature sensor in the IGBT module.

Troubleshooting:

ALARM 67, Option module configuration has changed

One or more options have either been added or removed since the last power-down.

**ALARM 68, Safe stop activated**

Safe stop has been activated. To resume normal operation, apply 24 V DC to terminal 37, then send a reset signal (via Bus, Digital I/O, or by pressing [Reset]. See 5-19 *Terminal 37 Digital Input*.

ALARM 69, Power card temperature

The temperature sensor on the power card is either too hot or too cold.

ALARM 70, Illegal Drive Configuration

Actual combination of control board and power board is illegal.

WARNING 73, Safe stop auto restart

Safe stopped. Note that with automatic restart enabled, the motor may start when the fault is cleared.

WARNING 77, Reduced power mode:

This warning indicates that the frequency converter is operating in reduced power mode (i.e. less than the allowed number of inverter sections). This warning will be generated on power cycle when the frequency converter is set to run with fewer inverters and will remain on.

ALARM 79, Illegal power section configuration

The scaling card is the incorrect part number or not installed. Also MK102 connector on the power card could not be installed.

ALARM 80, Unit Restored to Factory Settings

Parameter settings are restored to factory settings after a manual reset.

ALARM 244, Heatsink temperature

Report value indicates source of alarm (from left):
1-4 Inverter
5-8 Rectifier

ALARM 245, Heatsink sensor

No feedback from the heatsink sensor. Report value indicates source of alarm (from left):
1-4 Inverter
5-8 Rectifier

ALARM 246, Power card supply

The supply on the power card is out of range Report value indicates source of alarm (from left):
1-4 Inverter
5-8 Rectifier

ALARM 247, Power card temperature

Power card over temperature Report value indicates source of alarm (from left):
1-4 Inverter
5-8 Rectifier

ALARM 248, Illegal power section configuration

Power size configuration fault on the power card Report value indicates source of alarm (from left):
1-4 Inverter
5-8 Rectifier

ALARM 249, Rect. low temp.

The temperature of the rectifier heat sink is too low. This could indicate that the temperature sensor is defect.

ALARM 250, New spare part

The power or switch mode power supply has been exchanged. The filter type code must be restored in the EEPROM. Remember to select 'Save to EEPROM' to complete.

ALARM 251, New

The filter has a new .

ALARM 300, Mains Cont. Fault

The feedback from the mains contactor did not match the expected value within the allowed time frame. Contact your Danfoss supplier.

ALARM 301, SC Cont. Fault

The feedback from the soft charge contactor did not match the expected value within the allowed time frame. Contact your Danfoss supplier.

ALARM 302, Cap. Over Current

Excessive current was detected through the AC capacitors. Contact your Danfoss supplier.

ALARM 303, Cap. Earth Fault

An earth fault was detected through the AC capacitor currents. Contact your Danfoss supplier.

ALARM 304, DC Over Current

Excessive current through the DC link capacitor bank was detected. Contact your Danfoss supplier.

ALARM 305, Mains Freq. Limit

The mains frequency was outside the limits. Verify that the mains frequency is within product specification.

ALARM 306, Compensation Limit

The needed compensation current exceeds unit capability. Unit is running at full compensation.

ALARM 308, Resistor temp

Excessive resistor heatsink temperature detected.

ALARM 309, Mains Earth Fault

An earth fault was detected in the mains currents. Check the mains for shorts and leakage current.

ALARM 310, RTDC Buffer Full

Contact your Danfoss supplier.

ALARM 311, Switch. Freq. Limit

The average switching frequency of the unit exceeded the limit. Verify that *300-10 Active Filter Nominal Voltage* and *300-22 CT Nominal Voltage* are set correctly. If so, contact your Danfoss supplier.

ALARM 312, CT Range

Current transformer measurement limitation was detected. Verify that the CTs used are an appropriate ratio.

ALARM 314, Auto CT Interrupt

Auto CT detection was interrupted by the user.

**ALARM 315, Auto CT Error**

An error was detected while performing auto CT detection.
Contact your Danfoss supplier.

ALARM 316, CT Location Error

The Auto CT function could not determine the correct locations of the CTs.

ALARM 317, CT Polarity Error

The Auto CT function could not determine the correct polarity of the CTs.

ALARM 318, CT Ratio Error

The Auto CT function could not determine the correct primary rating of the CTs.



Index	Cooling 29
A	D
Acceleration Time 78	Data
Access To Control Terminals 48	Readouts..... 119, 138
AF	Readouts 2..... 121
Readouts..... 140	DC Link 162, 170
Settings..... 139	Default Settings 100
Airflow 29	Digital
Alarm Messages 157	In/Out..... 108, 135
Alarms And Warnings 167	Inputs..... 149
Analog	Output..... 151
I/O Option MCB 109..... 130	Display
In/Out..... 110	Line 1.2 Small, 0-21..... 75
Inputs..... 150	Line 1.3 Small, 0-22..... 75
Output..... 150	Line 2 Large, 0-23..... 75
Application Functions 125	Line 3 Large, 0-24..... 75
Approvals 6	Disposal Instruction 11
Auto Tune 53	Drip Shield Installation 33
B	Drive
Back Cooling 29	Closed Loop, 20-**..... 88
Brake Control 163	Control Tool DCT 10..... 63
Brakes 105	Drives With Factory Installed A1/B1 RFI Filter Option 42
Branch Circuit Protection 45	E
Bypass Option 134	Earthing 42
C	Efficient Parameter Set-up For Water Applications 65
Cable Lengths And Cross Sections 149	ELCB Relays 42
Cable-length And Cross-section 34	Electrical Installation 48, 51
Cabling 33	Electronic Waste 11
CAN Fieldbus 114	EMC Precautions 142
Cascade	Ext. Closed Loop 123
Controller..... 128	External Fan Supply 44
CTL Option..... 131	F
Changing	Fault Messages - Active Filter 170
A Group Of Numeric Data Values..... 61	FC
A Text Value..... 59	Closed Loop..... 122
Data..... 59	Information..... 117, 136
Of Data Value..... 61	Fuse Specifications 45
Coasting 59	Fuses 45
Comm. And Options 112, 135	Fusing 33
Communication Option 164	G
Control	General
Cables..... 52, 51	Considerations..... 22
Card Performance..... 152	Settings..... 76
Card, 10 V DC Output..... 151	Gland/Conduit Entry - IP21 (NEMA 1) And IP54 (NEMA12) ... 30
Card, 24 V DC Output..... 151	Graphical Display 55
Card, RS-485 Serial Communication..... 150	
Card, USB Serial Communication..... 152	
Characteristics..... 151	
Terminals..... 48	



H	
How	
To Connect A PC To The Frequency Converter.....	62
To Operate Graphical LCP (GLCP).....	55
I	
Index (IND).....	145
Indexed Parameters.....	61
Indicator Lights (LEDs):.....	56
Input Polarity Of Control Terminals.....	52
Installation	
At High Altitudes.....	7
Of Mains Shield For Frequency Converters.....	33
IT Mains.....	42
K	
Keypad.....	0
KTY Sensor.....	162
L	
Language	
- Parameter, 0-01.....	72
Package 1.....	72
Package 2.....	72
Package 3.....	72
Package 4.....	72
LCP 102.....	55
Leakage Current.....	8
LEDs.....	55
Legal Information.....	5
Lifting.....	15
Limits/Warnings.....	107
Load Sharing.....	43
Load/Motor.....	103
M	
Main	
Menu.....	64
Menu Mode.....	57, 69
Reactance.....	77
Mains	
Connection.....	44
Supply (L1, L2, L3).....	149
Mechanical	
Dimensions.....	17
Installation.....	22
Motor	
Bearing Currents.....	47
Cable.....	43
Name Plate.....	53
Output.....	149
Protection.....	152
N	
Name Plate Data.....	53
Network Connection.....	141
O	
Operation/Display.....	101, 134
Output Performance (U, V, W).....	149
P	
Parallel Connection Of Motors.....	54
Parameter	
Options.....	100
Selection.....	69
Set-up.....	64
Values.....	148
PC Software Tools.....	63
Planning The Installation Site.....	14
Potentiometer Reference.....	50
Power Connections.....	33
Profibus	
Profibus.....	113
DP-V1.....	63
Protection And Features.....	152
Protocol Overview.....	142
Pulse	
Inputs.....	150
Start/Stop.....	49
Q	
Q1 My Personal Menu.....	65
Q2 Quick Setup.....	66
Q3 Function Setups.....	66
Q5 Changes Made.....	69
Q6 Loggings.....	69
Quick	
Menu.....	57, 64, 65
Menu Mode.....	57
Transfer Of Parameter Settings When Using Keypad.....	61
R	
Receiving The Frequency Converter.....	15
Reference/Ramps.....	106
Relay Outputs.....	151
Reset.....	59
Residual Current Device.....	8
RS-485	
RS-485.....	141
Bus Connection.....	62



S	
Safe Stop Installation.....	8
Safety	
Category 3 (EN 954-1).....	9
Note.....	7
Screened/armoured.....	44
Screening Of Cables.....	33
Serial Communication.....	152
Shielded Cables.....	42
Smart Logic.....	115
Software Version And Approvals.....	6
Space.....	22
Special Functions.....	116, 136
Speed Up/Down.....	50
Start/Stop.....	49
Stator Leakage Reactance.....	77
Status	
Status.....	57
Messages.....	55
Step-by-Step.....	61
Stopping Category 0 (EN 60204-1).....	9
Surroundings.....	152
Switches S201, S202, And S801.....	52
Switching Frequency.....	34
Symbols.....	6
T	
Telegram Length (LGE).....	143
Terminal Locations - Frame Size D13.....	23
Timed Actions.....	127
Torque	
Torque.....	42
Characteristics.....	149
For Terminals.....	42
U	
Unpacking.....	15
V	
Voltage	
Level.....	149
Reference Via A Potentiometer.....	50
W	
Warning Against Unintended Start.....	7
Warnings.....	157
Water Application Functions.....	99, 133
Wire Access.....	22