

Motor-independent Frequency Converter
for centrifugal pumps

PumpDrive R (KSB202)

Operating range 0.25-90 kW

Installation/Operating Manual



NOTICE

Use the KSB202 frequency converter with synchronous reluctance motors (SynRM) only in pump and fan applications.

NOTICE

Do not operate the KSB202 frequency converter with synchronous reluctance motors (SynRM) above 200 rpm without coupling of a load! For checking the sense of rotation, use the designated function *chapter 5.5 Checking Motor Rotation*.

Contents

1 Introduction	4
1.1 Purpose of the Operating Instructions	4
1.2 Additional Resources	4
1.3 Document and Software Version	4
1.4 Product Overview	4
1.5 Approvals and Certifications	8
1.6 Disposal	8
2 Safety	9
2.1 Safety Symbols	9
2.2 Qualified Personnel	9
2.3 Safety Precautions	9
3 Mechanical Installation	11
3.1 Unpacking	11
3.2 Installation Environments	11
3.3 Mounting	11
4 Electrical Installation	13
4.1 Safety Instructions	13
4.2 EMC-compliant Installation	13
4.3 Grounding	13
4.4 Wiring Schematic	14
4.5 Access	16
4.6 Motor Connection	16
4.7 AC Mains Connection	17
4.8 Control Wiring	17
4.8.1 Control Terminal Types	17
4.8.2 Wiring to Control Terminals	19
4.8.3 Enabling Motor Operation (Terminal 27)	19
4.8.4 Voltage/Current Input Selection (Switches)	19
4.8.5 RS485 Serial Communication	20
4.9 Installation Check List	21
5 Commissioning	22
5.1 Safety Instructions	22
5.2 Applying Power	22
5.3 Local Control Panel Operation	22
5.3.1 Local Control Panel	22
5.3.2 GLCP Layout	23

5.3.3 Parameter Settings	24
5.3.4 Uploading/Downloading Data to/from the LCP	24
5.3.5 Changing Parameter Settings	24
5.3.6 Restoring Default Settings	24
5.4 Basic Programming	25
5.4.1 Commissioning with SmartStart	25
5.4.2 Commissioning via [Main Menu]	25
5.4.3 Asynchronous Motor Set-up	26
5.4.4 PM Motor Setup in VVC ⁺	27
5.4.5 SynRM Motor Set-up with VVC ⁺	28
5.4.6 Automatic Energy Optimisation (AEO)	29
5.4.7 Automatic Motor Adaptation (AMA)	29
5.5 Checking Motor Rotation	29
5.6 Local-control Test	30
5.7 System Start-up	31
6 Application Set-up Examples	32
7 Maintenance, Diagnostics and Troubleshooting	36
7.1 Maintenance and Service	36
7.2 Status Messages	36
7.3 Warning and Alarm Types	38
7.4 List of Warnings and Alarms	39
7.5 Troubleshooting	46
8 Specifications	49
8.1 Electrical Data	49
8.1.1 Mains Supply 1x200–240 V AC	49
8.1.2 Mains Supply 3x200–240 V AC	50
8.1.3 Mains Supply 1x380–480 V AC	52
8.1.4 Mains Supply 3x380–480 V AC	53
8.1.5 Mains Supply 3x525–600 V AC	57
8.1.6 Mains Supply 3x525–690 V AC	61
8.2 Mains Supply	64
8.3 Motor Output and Motor Data	64
8.4 Ambient Conditions	65
8.5 Cable Specifications	65
8.6 Control Input/Output and Control Data	65
8.7 Connection Tightening Torques	68
8.8 Fuses and Circuit Breakers	69
8.9 Power Ratings, Weight, and Dimensions	76

9 Appendix	78
9.1 Symbols, Abbreviations, and Conventions	78
9.2 Parameter Menu Structure	78
Index	83

1 Introduction

1.1 Purpose of the Operating Instructions

These operating instructions provide information for safe installation and commissioning of the frequency converter.

The operating instructions are intended for use by qualified personnel.

Read and follow the operating instructions to use the frequency converter safely and professionally, and pay particular attention to the safety instructions and general warnings. Keep these operating instructions available with the frequency converter at all times.

1.2 Additional Resources

Other resources are available to understand advanced frequency converter functions and programming.

- The *Programming Guide* provides greater detail on working with parameters and many application examples.
- The *Design Guide* provides detailed information about capabilities and functionality to design motor control systems.
- Instructions for operation with optional equipment.

1.3 Document and Software Version

This manual is regularly reviewed and updated. All suggestions for improvement are welcome. Please send suggestions via email to techcom_change_request@danfoss.com, including a reference to the document version.

Table 1.1 shows the document version and the corresponding software version.

Edition	Remarks	Software version
MG21H2xx	Replaces MG21H1xx	2.x

Table 1.1 Document and Software Version

1.4 Product Overview

1.4.1 Intended Use

The frequency converter is an electronic motor controller intended for:

- Regulation of motor speed in response to system feedback or to remote commands from external controllers. A power drive system consists of the frequency converter, the motor, and equipment driven by the motor.
- System and motor status surveillance.

Depending on configuration, the frequency converter can be used in standalone applications or form part of a larger appliance or installation.

The frequency converter is allowed for use in residential, industrial, and commercial environments in accordance with local laws, standards, and emission limits as described in the design guide.

Single phase frequency converters (S2 and S4) installed in the EU

The following limitations apply:

- Units with an input current below 16 A and an input power above 1 kW are only intended for professional use in trades, professions, or industries and not for sale to the general public.
- Designated application areas are public pools, public water supplies, agriculture, commercial buildings, and industries. All other single phase units are only intended for use in private low-voltage systems interfacing with public supply only at a medium or high voltage level.
- Operators of private systems must ensure that the EMC environment complies with IEC 61000-3-6 and/or the contractual agreements.

NOTICE

In a residential environment, this product can cause radio interference, in which case supplementary mitigation measures may be required.

Foreseeable misuse

Do not use the frequency converter in applications, which are non-compliant with specified operating conditions and environments. Ensure compliance with the conditions specified in *chapter 8 Specifications*.

1.4.2 Features

The KSB202 is designed for water and wastewater applications. The range of standard and optional features includes:

- Cascade control.
- Dry run detection.
- End of curve detection.
- SmartStart.
- Motor alternation.
- Deragging.
- 2-step ramps.
- Flow Confirmation.
- Check valve protection.
- Safe Torque Off.
- Low flow detection.
- Pre/Post Lubrication.
- Pipe fill mode.
- Sleep mode.
- Real-time clock.
- User configurable info texts.
- Warnings and alarms.
- Password protection.
- Overload protection.
- Smart logic control.
- Dual Power rating (High/Normal Overload).

1.4.3 Exploded Views

1

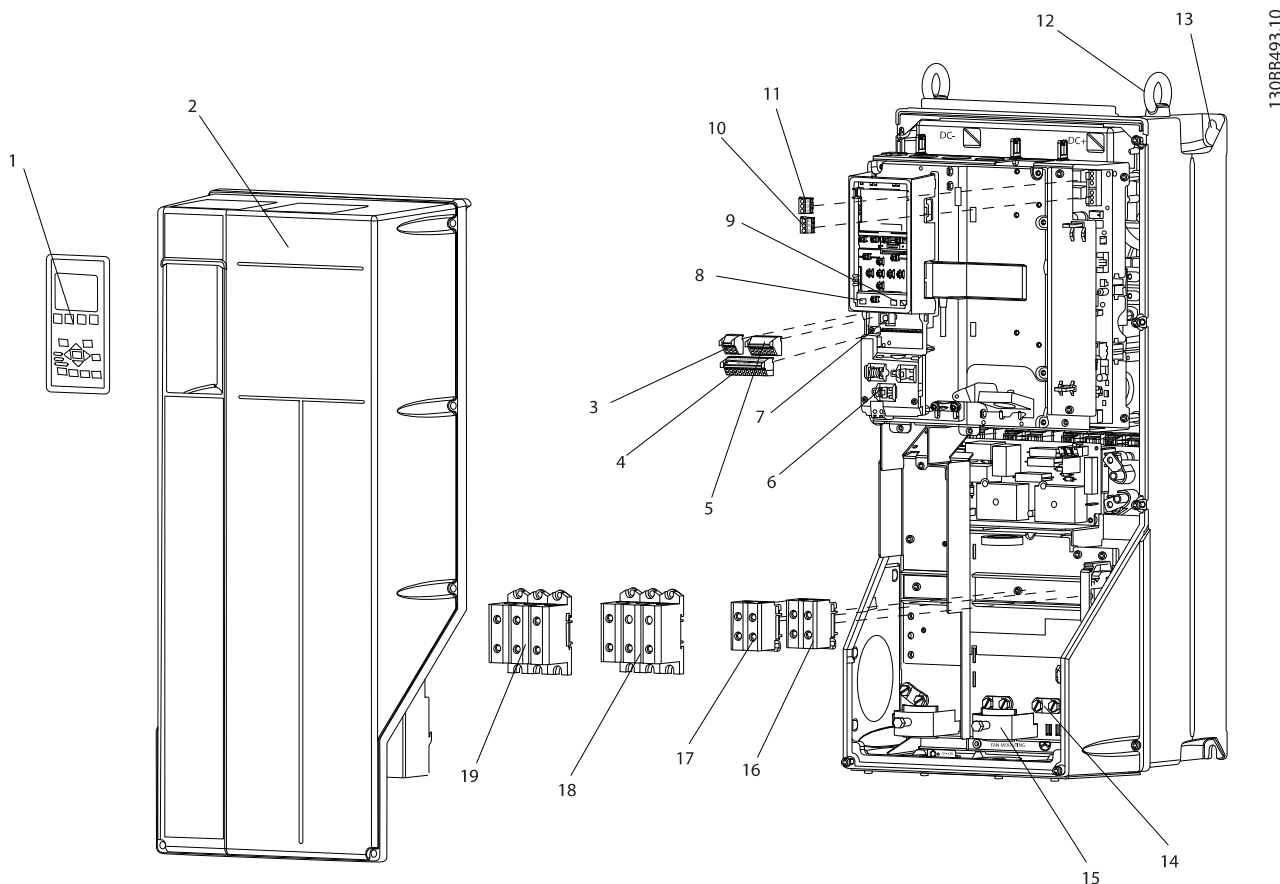

1	Local control panel (LCP)	11	Relay 2 (04, 05, 06)
2	Cover	12	Lifting ring
3	RS485 serial bus connector	13	Mounting slot
4	Digital I/O and 24 V power supply	14	Grounding clamp (PE)
5	Analog I/O connector	15	Cable screen connector
6	Cable screen connector	16	Brake terminal (-81, +82)
7	USB connector	17	Load sharing terminal (DC bus) (-88, +89)
8	Serial bus terminal switch	18	Motor output terminals 96 (U), 97 (V), 98 (W)
9	Analog switches (A53), (A54)	19	Mains input terminals 91 (L1), 92 (L2), 93 (L3)
10	Relay 1 (01, 02, 03)		

Illustration 1.1 Exploded View Enclosure Types B and C, IP55 and IP66

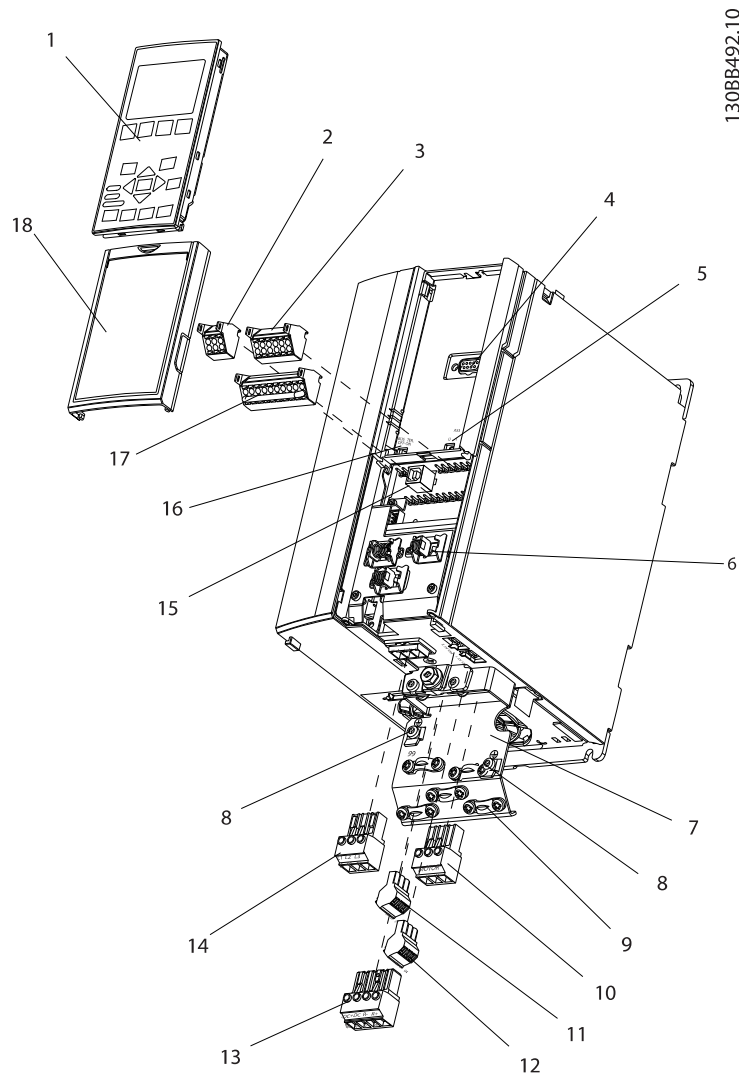

1	Local control panel (LCP)	10	Motor output terminals 96 (U), 97 (V), 98 (W)
2	RS485 serial bus connector (+68, -69)	11	Relay 2 (01, 02, 03)
3	Analog I/O connector	12	Relay 1 (04, 05, 06)
4	LCP input plug	13	Brake (-81, +82) and load sharing (-88, +89) terminals
5	Analog switches (A53), (A54)	14	Mains input terminals 91 (L1), 92 (L2), 93 (L3)
6	Cable screen connector	15	USB connector
7	Decoupling plate	16	Serial bus terminal switch
8	Grounding clamp (PE)	17	Digital I/O and 24 V power supply
9	Screened cable grounding clamp and strain relief	18	Cover

Illustration 1.2 Exploded View Enclosure Type A, IP20

Illustration 1.3 is a block diagram of the internal components of the frequency converter. See the table for Illustration 1.3 for their functions.

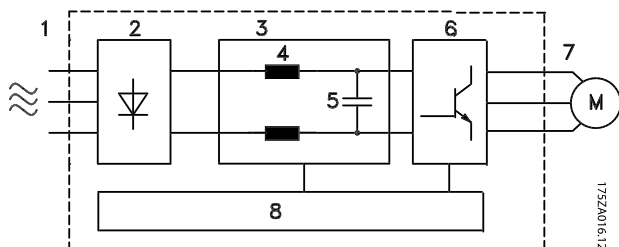

Area	Title	Functions
1	Mains input	<ul style="list-style-type: none"> 3-phase AC mains supply to the frequency converter.
2	Rectifier	<ul style="list-style-type: none"> The rectifier bridge converts the AC input to DC current to supply inverter power.
3	DC bus	<ul style="list-style-type: none"> Intermediate DC bus circuit handles the DC current.
4	DC reactors	<ul style="list-style-type: none"> Filter the intermediate DC circuit voltage. Provide mains transient protection. Reduce RMS current. Raise the power factor reflected back to the line. Reduce harmonics on the AC input.
5	Capacitor bank	<ul style="list-style-type: none"> Stores the DC power. Provides ride-through protection for short power losses.
6	Inverter	<ul style="list-style-type: none"> Converts the DC into a controlled PWM AC waveform for a controlled variable output to the motor.
7	Output to motor	<ul style="list-style-type: none"> Regulated 3-phase output power to the motor.
8	Control circuitry	<ul style="list-style-type: none"> Input power, internal processing, output, and motor current are monitored to provide efficient operation and control. User interface and external commands are monitored and performed. Status output and control can be provided.

Illustration 1.3 Frequency Converter Block Diagram

1.4 Enclosure Types and Power Ratings

For enclosure types and power ratings of the frequency converters, refer to chapter 8.9 Power Ratings, Weight, and Dimensions.

1.5 Approvals and Certifications



More approvals and certifications are available. Contact the local KSB partner. Frequency converters of enclosure type T7 (525–690 V) are UL certified for only 525–600 V.

The frequency converter complies with UL508C thermal memory retention requirements. For more information, refer to the section *Motor Thermal Protection* in the VLT® AQUA Drive FC 202 Design Guide.

For compliance with the European Agreement concerning International Carriage of Dangerous Goods by Inland Waterways (ADN), refer to *ADN-compliant Installation* in the product specific design guide.

1.6 Disposal

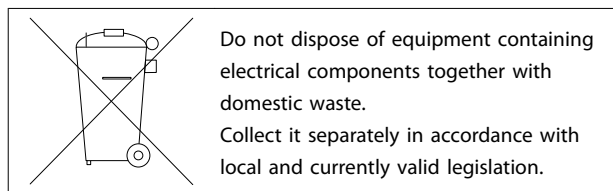

2 Safety

2.1 Safety Symbols

The following symbols are used in this manual:



Indicates a potentially hazardous situation that could result in death or serious injury.



Indicates a potentially hazardous situation that could result in minor or moderate injury. It can also be used to alert against unsafe practices.

NOTICE

Indicates important information, including situations that can result in damage to equipment or property.

2.2 Qualified Personnel

Correct and reliable transport, storage, installation, operation, and maintenance are required for the trouble-free and safe operation of the frequency converter. Only qualified personnel are allowed to install or operate this equipment.

Qualified personnel are defined as trained staff, who are authorised to install, commission, and maintain equipment, systems, and circuits in accordance with pertinent laws and regulations. Additionally, the qualified personnel must be familiar with the instructions and safety measures described in these operating instructions.

2.3 Safety Precautions



HIGH VOLTAGE

Frequency converters contain high voltage when connected to AC mains input, DC supply, or load sharing. Failure to perform installation, start-up, and maintenance by qualified personnel can result in death or serious injury.

- Installation, start-up, and maintenance must be performed by qualified personnel only.



UNINTENDED START

When the frequency converter is connected to AC mains, DC supply, or load sharing, the motor may start at any time. Unintended start during programming, service, or repair work can result in death, serious injury, or property damage. The motor can start via an external switch, a serial bus command, an input reference signal from the LCP, or after a cleared fault condition.

To prevent unintended motor start:

- Disconnect the frequency converter from the mains.
- Press [Off/Reset] on the LCP before programming parameters.
- Fully wire and assembly the frequency converter, motor, and any driven equipment before connecting the frequency converter to AC mains, DC supply, or load sharing.



DISCHARGE TIME

The frequency converter contains DC-link capacitors, which can remain charged even when the frequency converter is not powered. Failure to wait the specified time after power has been removed before performing service or repair work, could result in death or serious injury.

1. Stop the motor.
2. Disconnect the AC mains, permanent magnet type motors, and remote DC-link power supplies, including battery back-ups, UPS, and DC-link connections to other frequency converters.
3. Wait for the capacitors to discharge fully before performing any service or repair work. The duration of waiting time is specified in *Table 2.1*.

Voltage [V]	Minimum waiting time (minutes)		
	4	7	15
200–240	0.25–3.7 kW		5.5–45 kW
380–480	0.37–7.5 kW		11–90 kW
525–600	0.75–7.5 kW		11–90 kW
525–690		1.1–7.5 kW	11–90 kW

High voltage may be present even when the warning LED indicator lights are off.

Table 2.1 Discharge Time

⚠ WARNING**LEAKAGE CURRENT HAZARD**

Leakage currents exceed 3.5 mA. Failure to ground the frequency converter properly can result in death or serious injury.

- Ensure the correct grounding of the equipment by a certified electrical installer.

⚠ WARNING**EQUIPMENT HAZARD**

Contact with rotating shafts and electrical equipment can result in death or serious injury.

- Ensure that only trained and qualified personnel perform installation, start-up, and maintenance.
- Ensure that electrical work conforms to national and local electrical codes.
- Follow the procedures in this manual.

⚠ WARNING**UNINTENDED MOTOR ROTATION
WINDMILLING**

Unintended rotation of permanent magnet motors creates voltage and can charge the unit, resulting in death, serious injury, or equipment damage.

- Ensure that permanent magnet motors are blocked to prevent unintended rotation.

⚠ CAUTION**INTERNAL FAILURE HAZARD**

An internal failure in the frequency converter can result in serious injury, when the frequency converter is not properly closed.

- Ensure that all safety covers are in place and securely fastened before applying power.

3 Mechanical Installation

3.1 Unpacking

3.1.1 Items Supplied

Items supplied may vary according to product configuration.

- Make sure the items supplied and the information on the nameplate correspond to the order confirmation.
- Check the packaging and the frequency converter visually for damage caused by inappropriate handling during shipment. File any claim for damage with the carrier. Retain damaged parts for clarification.

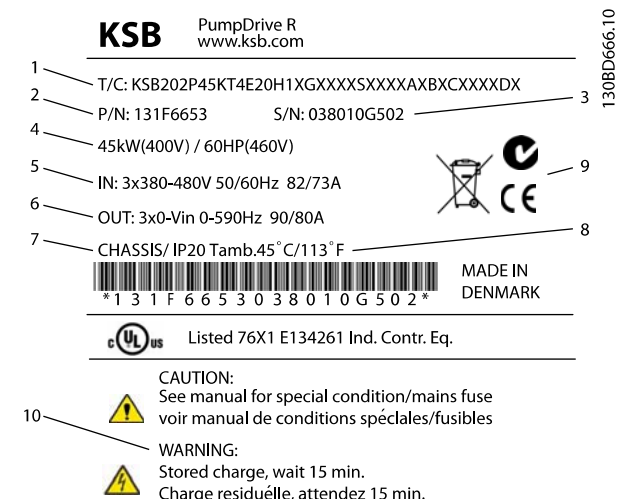

1	Type code
2	Order number
3	Serial number
4	Power rating
5	Input voltage, frequency and current (at low/high voltages)
6	Output voltage, frequency and current (at low/high voltages)
7	Enclosure type and IP rating
8	Maximum ambient temperature
9	Certifications
10	Discharge time (Warning)

Illustration 3.1 Product Nameplate (Example)

NOTICE

Do not remove the nameplate from the frequency converter. Removing the nameplate voids the warranty.

3.1.2 Storage

Ensure that the requirements for storage are fulfilled. Refer to *chapter 8.4 Ambient Conditions* for further details.

3.2 Installation Environments

NOTICE

In environments with airborne liquids, particles, or corrosive gases, ensure that the IP/type rating of the equipment matches the installation environment. Failure to meet requirements for ambient conditions can reduce the lifetime of the frequency converter. Ensure that requirements for air humidity, temperature, and altitude are met.

Vibration and shock

The frequency converter complies with requirements for units mounted on the walls and floors of production premises, as well as in panels bolted to walls or floors.

For detailed ambient conditions specifications, refer to *chapter 8.4 Ambient Conditions*.

3.3 Mounting

NOTICE

Improper mounting can result in overheating and reduced performance.

Cooling

- Ensure that top and bottom clearance for air cooling is provided. See *Illustration 3.2* for clearance requirements.

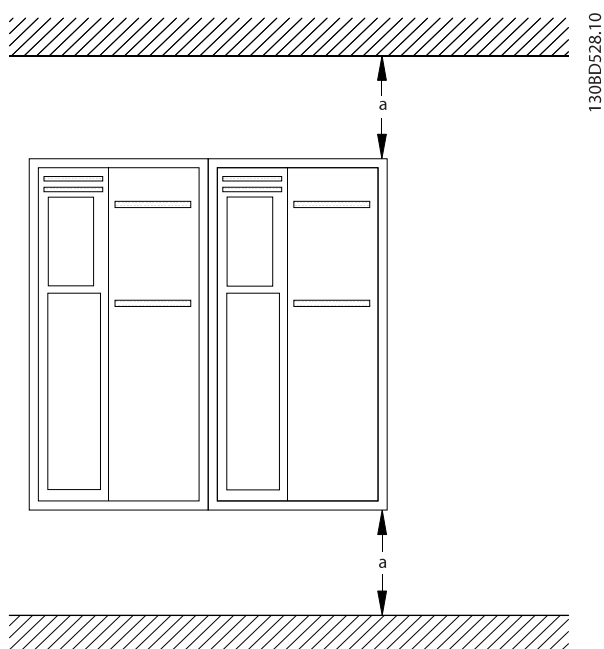

Enclosure	A2-A5	B1-B4	C1, C3	C2, C4
a [mm]	100	200	200	225

Illustration 3.2 Top and Bottom Cooling Clearance

Lifting

- To determine a safe lifting method, check the weight of the unit, see *chapter 8.9 Power Ratings, Weight, and Dimensions*.
- Ensure that the lifting device is suitable for the task.
- If necessary, plan for a hoist, crane, or forklift with the appropriate rating to move the unit.
- For lifting, use the hoist rings on the unit, when provided.

Mounting

1. Ensure that the strength of the mounting location supports the unit weight. The frequency converter allows side-by-side installation.
2. Locate the unit as near to the motor as possible. Keep the motor cables as short as possible.
3. Mount the unit vertically to a solid flat surface or to the optional back plate to provide cooling airflow.
4. Use the slotted mounting holes on the unit for wall mounting, when provided.

Mounting with back plate and railings

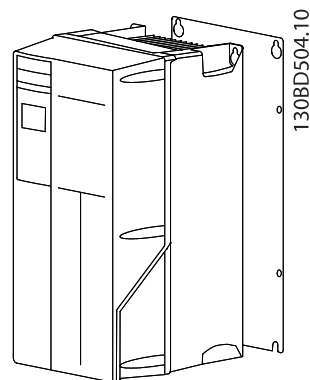

Illustration 3.3 Proper Mounting with Back Plate

NOTICE

A back plate is required when mounted on railings.

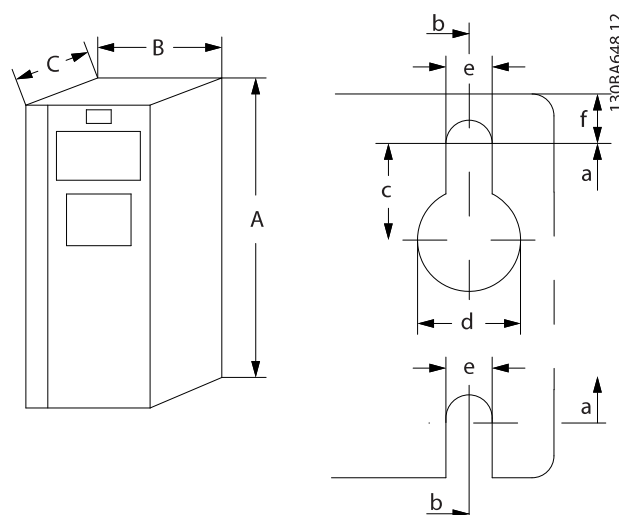

Illustration 3.4 Top and Bottom Mounting Holes (See *chapter 8.9 Power Ratings, Weight, and Dimensions*)

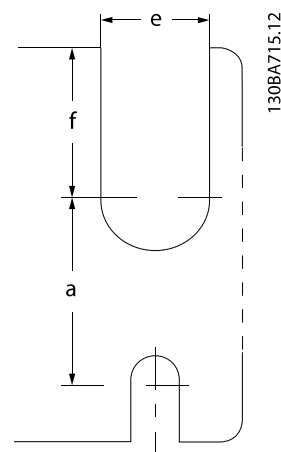

Illustration 3.5 Top and Bottom Mounting Holes (B4, C3, C4)

4 Electrical Installation

4.1 Safety Instructions

See *chapter 2 Safety* for general safety instructions.

WARNING

INDUCED VOLTAGE

Induced voltage from output motor cables that run together can charge equipment capacitors, even with the equipment turned off and locked out. Failure to run output motor cables separately or use screened cables could result in death or serious injury.

- Run output motor cables separately, or
- Use screened cables.

CAUTION

SHOCK HAZARD

The frequency converter can cause a DC current in the PE conductor. Failure to follow the recommendation means that the RCD may not provide the intended protection.

- When a residual current-operated protective device (RCD) is used for protection against electrical shock, only an RCD of Type B is permitted on the supply side.

Overcurrent protection

- Extra protective equipment, such as short-circuit protection or motor thermal protection between frequency converter and motor, is required for applications with multiple motors.
- Input fusing is required to provide short-circuit and overcurrent protection. If not factory-supplied, the installer must provide fuses. See maximum fuse ratings in *chapter 8.8 Fuses and Circuit Breakers*.

Wire type and ratings

- All wiring must comply with local and national regulations regarding cross-section and ambient temperature requirements.
- Power connection wire recommendation: Minimum 75 °C rated copper wire.

See *chapter 8.1 Electrical Data* and *chapter 8.5 Cable Specifications* for recommended wire sizes and types.

4.2 EMC-compliant Installation

To obtain an EMC-compliant installation, follow the instructions provided in *chapter 4.3 Grounding*, *chapter 4.4 Wiring Schematic*, *chapter 4.6 Motor Connection*, and *chapter 4.8 Control Wiring*.

4.3 Grounding

WARNING

LEAKAGE CURRENT HAZARD

Leakage currents exceed 3.5 mA. Failure to ground the frequency converter properly could result in death or serious injury.

- Ensure the correct grounding of the equipment by a certified electrical installer.

For electrical safety

- Ground the frequency converter in accordance with applicable standards and directives.
- Use a dedicated ground wire for input power, motor power, and control wiring.
- Do not ground one frequency converter to another in a daisy chain fashion.
- Keep the ground wire connections as short as possible.
- Follow motor manufacturer wiring requirements.
- Minimum cable cross-section: 10 mm² (or 2 rated ground wires terminated separately).

For EMC-compliant installation

- Establish electrical contact between the cable screen and the frequency converter enclosure by using metal cable glands or by using the clamps provided on the equipment (see *chapter 4.6 Motor Connection*).
- Use high-strand wire to reduce electrical interference.
- Do not use pigtailed.

NOTICE

POTENTIAL EQUALISATION

Risk of electrical interference, when the ground potential between the frequency converter and the control system is different. Install equalising cables between the system components. Recommended cable cross-section: 16 mm².

4.4 Wiring Schematic

4

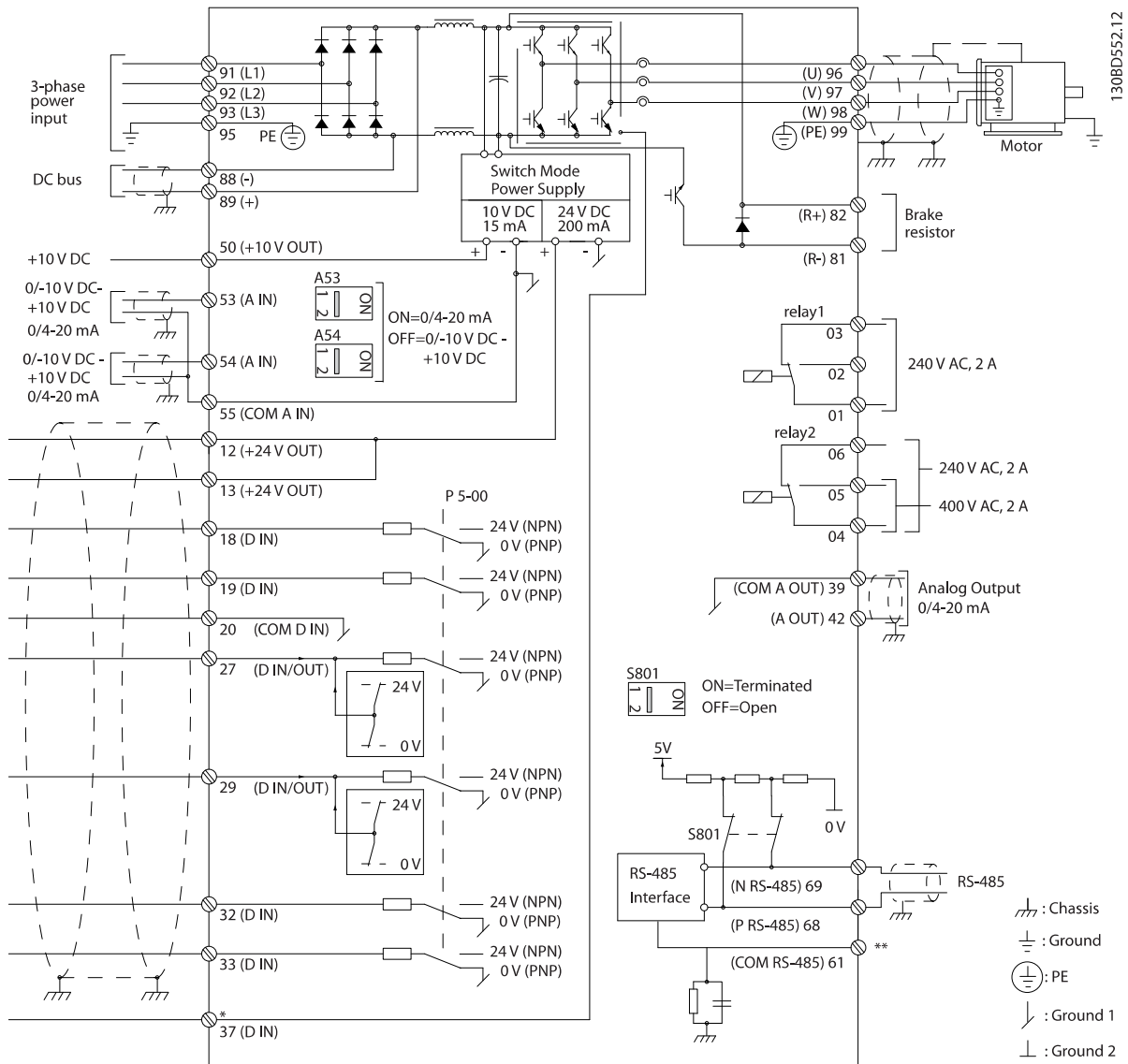
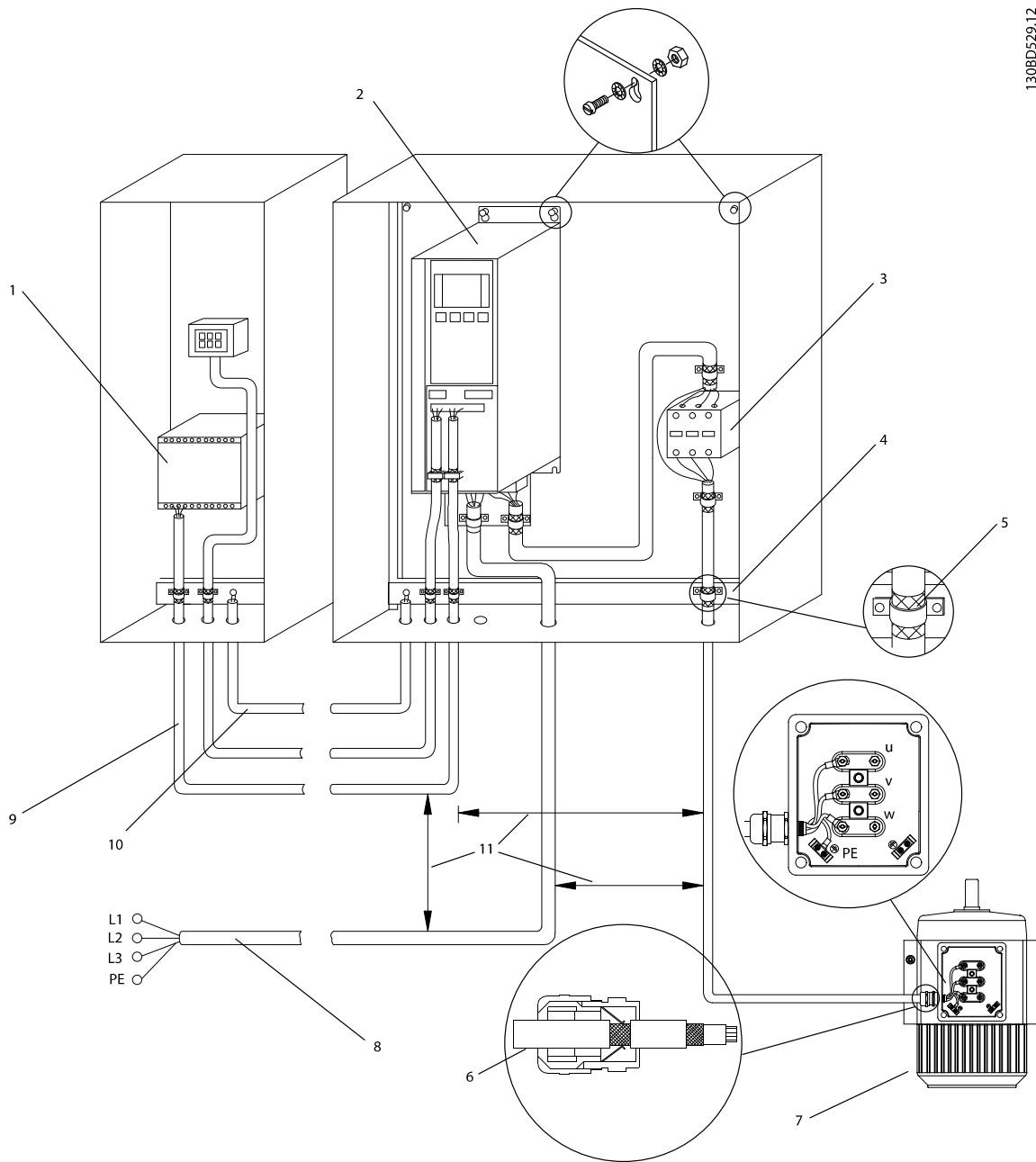

Illustration 4.1 Basic Wiring Schematic

A=Analog, D=Digital

*Terminal 37 (optional) is used for Safe Torque Off. For Safe Torque Off installation instructions, refer to the *VLT® Frequency Converters - Safe Torque Off Operating Instructions*.

**Do not connect cable screen.



1	PLC	6	Cable gland
2	Frequency converter	7	Motor, 3-phase and PE
3	Output contactor	8	Mains, 3-phase and reinforced PE
4	Grounding rail (PE)	9	Control wiring
5	Cable insulation (stripped)	10	Equalising min. 16 mm ² (0.025 in ²)

Illustration 4.2 EMC-compliant Electrical Connection

NOTICE

EMC INTERFERENCE

Use screened cables for motor and control wiring and separate cables for input power, motor wiring, and control wiring. Failure to isolate power, motor, and control cables can result in unintended behaviour or reduced performance. Minimum clearance requirement between power, motor and control cables is 200 mm (7.9 in).

4.5 Access

- Remove the cover with a screw driver (See *Illustration 4.3*) or by loosening the attaching screws (See *Illustration 4.4*).

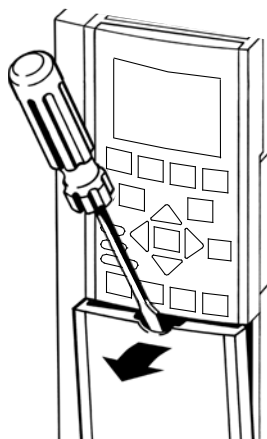

130BT248

Illustration 4.3 Access to Wiring for IP20 and IP21 Enclosures

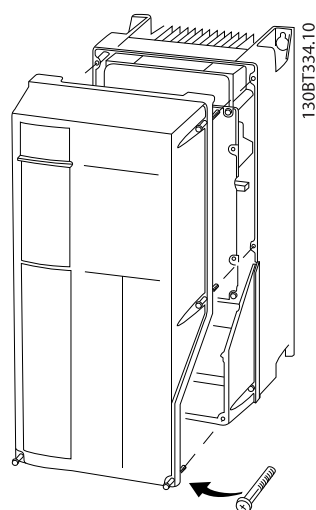

Illustration 4.4 Access to Wiring for IP55 and IP66 Enclosures

Tighten the cover screws using the tightening torques specified in *Table 4.1*.

Enclosure	IP55	IP66
A4/A5	2	2
B1/B2	2.2	2.2
C1/C2	2.2	2.2
No screws to tighten for A2/A3/B3/B4/C3/C4.		

Table 4.1 Tightening Torques for Covers [Nm]

4.6 Motor Connection

WARNING

INDUCED VOLTAGE

Induced voltage from output motor cables that run together can charge equipment capacitors, even with the equipment turned off and locked out. Failure to run output motor cables separately or use screened cables could result in death or serious injury.

- Run output motor cables separately, or
- Use screened cables.
- Comply with local and national electrical codes for cable sizes. For maximum wire sizes see *chapter 8.1 Electrical Data*.
- Follow motor manufacturer wiring requirements.
- Motor wiring knockouts or access panels are provided at the base of IP21 (NEMA1/12) and higher units.
- Do not wire a starting or pole-changing device (e.g. Dahlander motor or slip ring induction motor) between the frequency converter and the motor.

Procedure

- Strip a section of the outer cable insulation.
- Position the stripped wire under the cable clamp to establish mechanical fixation and electrical contact between the cable screen and ground.
- Connect the ground wire to the nearest grounding terminal in accordance with the grounding instructions provided in *chapter 4.3 Grounding*, see *Illustration 4.5*.
- Connect the 3-phase motor wiring to terminals 96 (U), 97 (V), and 98 (W), see *Illustration 4.5*.
- Tighten the terminals in accordance with the information provided in *chapter 8.7 Connection Tightening Torques*.

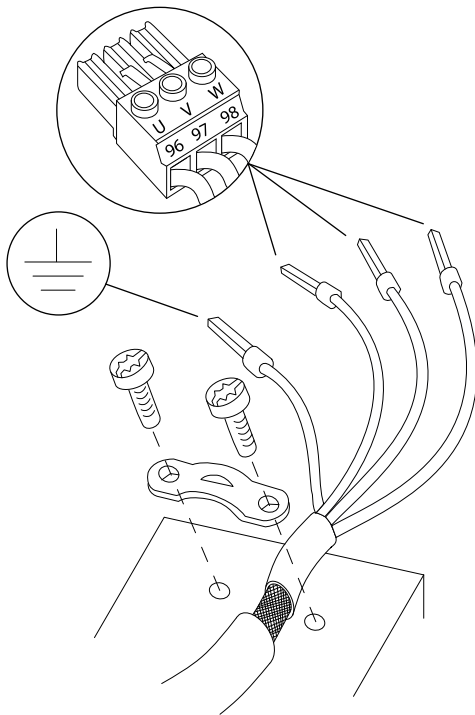

1308D531.10

Illustration 4.5 Motor Connection

Illustration 4.6 represents mains input, motor and grounding for basic frequency converters. Actual configurations vary with unit types and optional equipment.

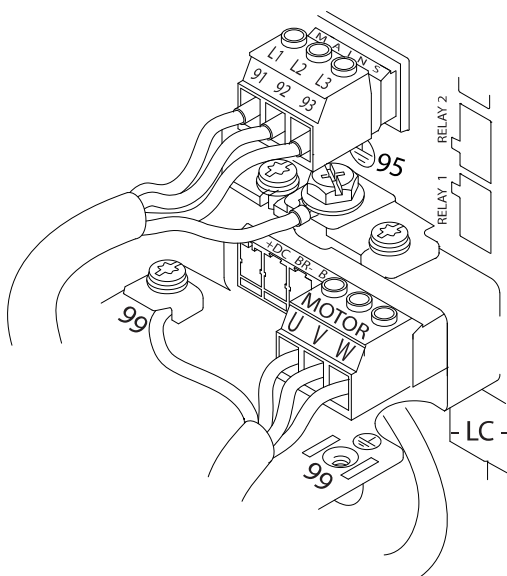

1308B920.10

Illustration 4.6 Example of Motor, Mains and Ground Wiring

4.7 AC Mains Connection

- Size the wiring based upon the input current of the frequency converter. For maximum wire sizes, see *chapter 8.1 Electrical Data*.
- Comply with local and national electrical codes for cable sizes.

Procedure

1. Connect the 3-phase AC input power wiring to terminals L1, L2, and L3 (see *Illustration 4.6*).
2. Depending on the configuration of the equipment, connect the input power to the mains input terminals or the input disconnect.
3. Ground the cable in accordance with the grounding instructions provided in *chapter 4.3 Grounding*.
4. When supplied from an isolated mains source (IT mains or floating delta) or TT/TN-S mains with a grounded leg (grounded delta), ensure that *parameter 14-50 RFI Filter* is set to [0] Off to avoid damage to the intermediate circuit and to reduce ground capacity currents in accordance with IEC 61800-3.

4.8 Control Wiring

- Isolate the control wiring from the high-power components in the frequency converter.
- When the frequency converter is connected to a thermistor, ensure that the thermistor control wiring is screened and reinforced/double insulated. A 24 V DC supply voltage is recommended.

4.8.1 Control Terminal Types

Illustration 4.7 and Illustration 4.8 show the removable frequency converter connectors. Terminal functions and default settings are summarised in *Table 4.2*.

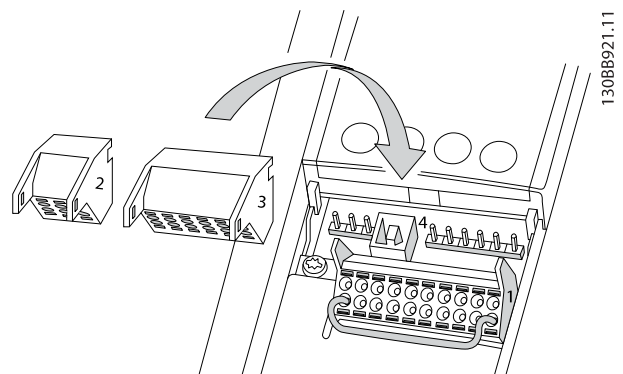

1308B921.11

Illustration 4.7 Control Terminal Locations

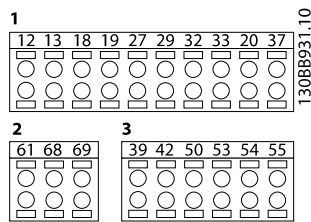

Illustration 4.8 Terminal Numbers

- **Connector 1** provides:
 - 4 programmable digital inputs terminals.
 - 2 additional digital terminals programmable as either input or output.
 - 24 V DC terminal supply voltage.
 - Optional customer supplied 24 V DC voltage.
- **Connector 2** terminals (+)68 and (-)69 are for an RS485 serial communication connection.
- **Connector 3** provides:
 - 2 analog inputs.
 - 1 analog output.
 - 10 V DC supply voltage.
 - Commons for the inputs and output.
- **Connector 4** is a USB port available for use with the MCT 10 Set-up Software.

4

Terminal description			
Terminal	Parameter	Default setting	Description
Digital Inputs/Outputs			
12, 13	-	+24 V DC	24 V DC supply voltage for digital inputs and external transducers. Maximum output current 200 mA for all 24 V loads.
18	5-10	[8] Start	Digital inputs.
19	5-11	[0] No operation	
32	5-14	[0] No operation	
33	5-15	[0] No operation	
27	5-12	[2] Coast inverse	For digital input or output. Default setting is input.
29	5-13	[14] JOG	
20	-		Common for digital inputs and 0 V potential for 24 V supply.

Terminal description			
Terminal	Parameter	Default setting	Description
37	-	Safe Torque Off (STO)	Safe input (optional). Used for STO.
Analog Inputs/Outputs			
39	-		Common for analog output
42	6-50	Speed 0 - High Limit	Programmable analog output. 0–20 mA or 4–20 mA at a maximum of 500 Ω
50	-	+10 V DC	10 V DC analog supply voltage for potentiometer or thermistor. 15 mA maximum
53	6-1	Reference	Analog input. For voltage or current. Switches A53 and A54 select mA or V.
54	6-2	Feedback	
55	-		Common for analog input
Serial Communication			
61	-		Integrated RC-Filter for cable screen. ONLY for connecting the screen in the event of EMC problems.
68 (+)	8-3		RS485 Interface. A control card switch is provided for termination resistance.
69 (-)	8-3		
Relays			
01, 02, 03	5-40 [0]	[9] Alarm	Form C relay output.
04, 05, 06	5-40 [1]	[5] Running	For AC or DC voltage and resistive or inductive loads.

Table 4.2 Terminal Description

Additional terminals:

- 2 form C relay outputs. Location of the outputs depends on frequency converter configuration.
- Terminals located on built-in optional equipment. See the manual provided with the equipment option.

4.8.2 Wiring to Control Terminals

Control terminal connectors can be unplugged from the frequency converter for ease of installation, as shown in *Illustration 4.9*.

NOTICE

Keep control wires as short as possible and separate from high power cables to minimise interference.

1. Open the contact by inserting a small screwdriver into the slot above the contact and push the screwdriver slightly upwards.

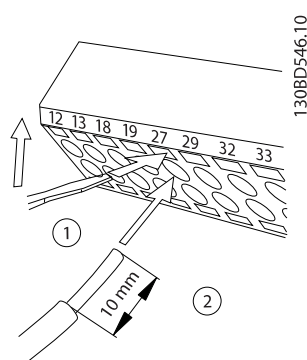

Illustration 4.9 Connecting Control Wires

2. Insert the bare control wire into the contact.
3. Remove the screwdriver to fasten the control wire into the contact.
4. Ensure that the contact is firmly established and not loose. Loose control wiring can be the source of equipment faults or less than optimal operation.

See *chapter 8.5 Cable Specifications* for control terminal wiring sizes and *chapter 6 Application Set-up Examples* for typical control wiring connections.

4.8.3 Enabling Motor Operation (Terminal 27)

A jumper wire is required between terminal 12 (or 13) and terminal 27 for the frequency converter to operate when using factory default programming values.

- Digital input terminal 27 is designed to receive 24 V DC external interlock command.
- When no interlock device is used, wire a jumper between control terminal 12 (recommended) or 13 to terminal 27. The jumper provides an internal 24 V signal on terminal 27.

- When the status line at the bottom of the LCP reads *AUTO REMOTE COAST*, it indicates that the unit is ready to operate but is missing an input signal on terminal 27.
- When factory installed optional equipment is wired to terminal 27, do not remove that wiring.

4.8.4 Voltage/Current Input Selection (Switches)

The analog input terminals 53 and 54 allow setting of input signal to voltage (0–10 V) or current (0/4–20 mA).

Default parameter setting:

- Terminal 53: Speed reference signal in open loop (see *parameter 16-61 Terminal 53 Switch Setting*).
- Terminal 54: Feedback signal in closed loop (see *parameter 16-63 Terminal 54 Switch Setting*).

NOTICE

Disconnect power to the frequency converter before changing switch positions.

1. Remove the LCP (local control panel) (see *Illustration 4.10*).
2. Remove any optional equipment covering the switches.
3. Set switches A53 and A54 to select the signal type. U selects voltage, I selects current.

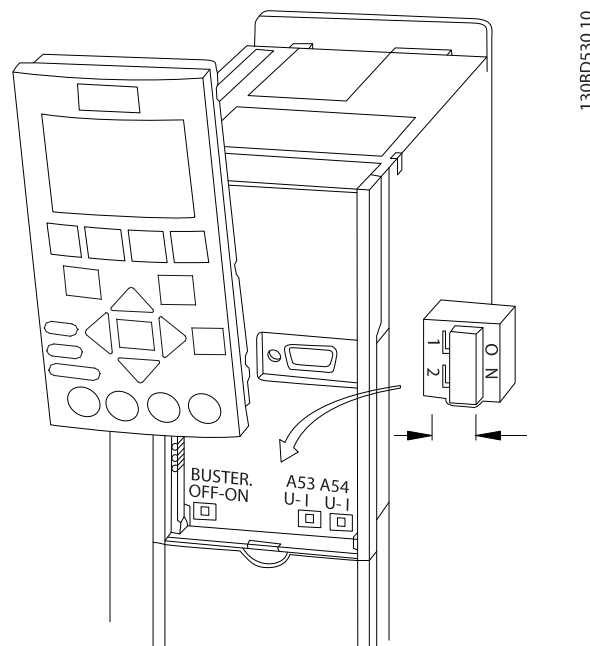

Illustration 4.10 Location of Terminal 53 and 54 Switches

To run STO, additional wiring for the frequency converter is required. Refer to *Safe Torque Off Operating Instructions* for further information.

4.8.5 RS485 Serial Communication

Connect RS485 serial communication wiring to terminals (+)68 and (-)69.

- Use screened serial communication cable (recommended).
- See *chapter 4.3 Grounding* for proper grounding.

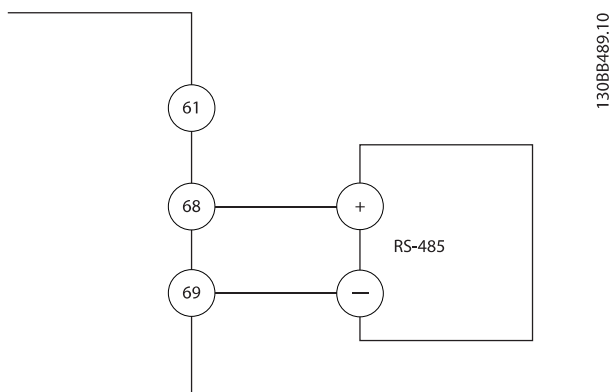

Illustration 4.11 Serial Communication Wiring Diagram

For basic serial communication set-up, select the following:

1. Protocol type in *parameter 8-30 Protocol*.
 2. Frequency converter address in *parameter 8-31 Address*.
 3. Baud rate in *parameter 8-32 Baud Rate*.
- 2 communication protocols are internal to the frequency converter.
 - KSB FC
 - Modbus RTU
 - Functions can be programmed remotely using the protocol software and RS485 connection or in parameter group 8-** *Communications and Options*.
 - Selecting a specific communication protocol changes various default parameter settings to match that protocol's specifications and makes additional protocol-specific parameters available.
 - Option cards for the frequency converter are available to provide additional communication protocols. See the option card documentation for installation and operation instructions.

4.9 Installation Check List

Before completing installation of the unit, inspect the entire installation as detailed in *Table 4.3*. Check and mark the items when completed.

Inspect for	Description	☑
Auxiliary equipment	<ul style="list-style-type: none"> Look for auxiliary equipment, switches, disconnects, or input fuses/circuit breakers, residing on the input power side of the frequency converter, or output side to the motor. Ensure that they are ready for full-speed operation. Check the function and installation of any sensors used for feedback to the frequency converter. Remove any power factor correction caps on the motor. Adjust any power factor correction caps on the mains side and ensure that they are dampened. 	
Cable routing	<ul style="list-style-type: none"> Ensure that the motor wiring and control wiring are separated, screened, or in 3 separate metallic conduits for high-frequency interference isolation. 	
Control wiring	<ul style="list-style-type: none"> Check for broken or damaged wires and loose connections. Check that the control wiring is isolated from power and motor wiring for noise immunity. Check the voltage source of the signals, if necessary. <p>The use of screened cable or twisted pair is recommended. Ensure that the screen is terminated correctly.</p>	
Cooling clearance	<ul style="list-style-type: none"> Ensure that the top and bottom clearance is adequate to ensure proper air flow for cooling, see <i>chapter 3.3 Mounting</i>. 	
Ambient conditions	<ul style="list-style-type: none"> Check that requirements for ambient conditions are met. 	
Fusing and circuit breakers	<ul style="list-style-type: none"> Check for proper fusing or circuit breakers. Check that all fuses are inserted firmly and are in operational condition, and that all circuit breakers are in the open position. 	
Grounding	<ul style="list-style-type: none"> Check for sufficient ground connections and ensure that those connections are tight and free of oxidation. Grounding to conduit, or mounting the back panel to a metal surface, is not a suitable grounding. 	
Input and output power wiring	<ul style="list-style-type: none"> Check for loose connections. Check that the motor and mains cables are in separate conduit or separated screened cables. 	
Panel interior	<ul style="list-style-type: none"> Inspect that the unit interior is free of dirt, metal chips, moisture, and corrosion. Check that the unit is mounted on an unpainted, metal surface. 	
Switches	<ul style="list-style-type: none"> Ensure that all switch and disconnect settings are in the proper positions. 	
Vibration	<ul style="list-style-type: none"> Check that the unit is mounted solidly, or that shock mounts are used, as necessary. Check for an unusual amount of vibration. 	

Table 4.3 Installation Check List

CAUTION

POTENTIAL HAZARD IN THE EVENT OF INTERNAL FAILURE

Risk of personal injury if the frequency converter is not properly closed.

- Before applying power, ensure that all safety covers are in place and securely fastened.

5 Commissioning

5.1 Safety Instructions

See *chapter 2 Safety* for general safety instructions.

⚠ WARNING

HIGH VOLTAGE

Frequency converters contain high voltage when connected to AC mains input power. Failure to perform installation, start-up, and maintenance by qualified personnel could result in death or serious injury.

- Installation, start-up, and maintenance must be performed by qualified personnel only.

Before applying power:

1. Close the cover properly.
2. Check that all cable glands are firmly tightened.
3. Ensure that input power to the unit is OFF and locked out. Do not rely on the frequency converter disconnect switches for input power isolation.
4. Verify that there is no voltage on input terminals L1 (91), L2 (92), and L3 (93), phase-to-phase and phase-to-ground.
5. Verify that there is no voltage on output terminals 96 (U), 97 (V), and 98 (W), phase-to-phase and phase-to-ground.
6. Confirm continuity of the motor by measuring Ω values on U-V (96-97), V-W (97-98), and W-U (98-96).
7. Check for proper grounding of the frequency converter as well as the motor.
8. Inspect the frequency converter for loose connections on the terminals.
9. Confirm that the supply voltage matches the voltage of the frequency converter and the motor.

5.2 Applying Power

Apply power to the frequency converter using the following steps:

1. Confirm that the input voltage is balanced within 3%. If not, correct the input voltage imbalance before proceeding. Repeat this procedure after the voltage correction.
2. Ensure that any optional equipment wiring, matches the installation application.

3. Ensure that all operator devices are in the OFF position. Panel doors must be closed and covers securely fastened.
4. Apply power to the unit. DO NOT start the frequency converter now. For units with a disconnect switch, turn it to the ON position to apply power to the frequency converter.

5.3 Local Control Panel Operation

5.3.1 Local Control Panel

The local control panel (LCP) is the combined display and keypad on the front of the unit.

The LCP has several user functions:

- Start, stop, and control speed when in local control.
- Display operational data, status, warnings and cautions.
- Programme frequency converter functions.
- Manually reset the frequency converter after a fault when auto-reset is inactive.

An optional numeric LCP (NLCP) is also available. The NLCP operates in a manner similar to the LCP. See the product relevant programming guide for details on use of the NLCP.

NOTICE

For commissioning via PC, install the MCT 10 Set-up Software.

5.3.2 GLCP Layout

The GLCP is divided into 4 functional groups (see *Illustration 5.1*).

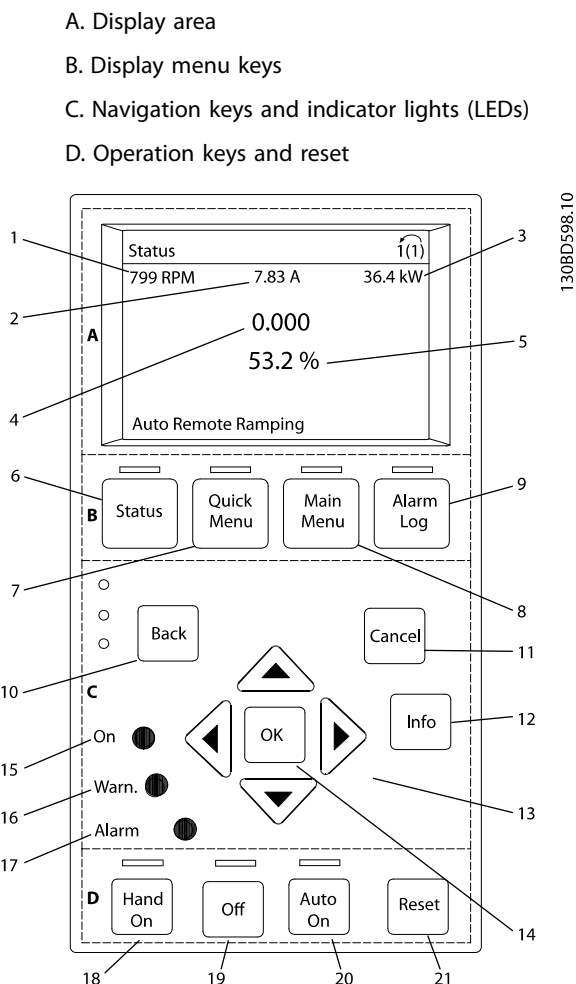

Illustration 5.1 Graphic Local Control Panel (GLCP)

A. Display area

The display area is activated when the frequency converter receives power from the mains voltage, a DC bus terminal, or an external 24 V DC supply.

The information displayed on the LCP can be customised for user application. Select options in the *Quick Menu* Q3-13 *Display Settings*.

Display	Parameter number	Default setting
1	0-20	Speed [RPM]
2	0-21	Motor Current
3	0-22	Power [kW]
4	0-23	Frequency
5	0-24	Reference [%]

Table 5.1 Legend to *Illustration 5.1*, Display Area

B. Display menu keys

Menu keys are used for menu access for parameter set-up, toggling through status display modes during normal operation, and viewing fault log data.

	Key	Function
6	Status	Shows operational information.
7	Quick Menu	Allows access to programming parameters for initial set-up instructions and many detailed application instructions.
8	Main Menu	Allows access to all programming parameters.
9	Alarm Log	Displays a list of current warnings, the last 10 alarms, and the maintenance log.

Table 5.2 Legend to *Illustration 5.1*, Display Menu Keys

C. Navigation keys and indicator lights (LEDs)

Navigation keys are used for programming functions and moving the display cursor. The navigation keys also provide speed control in local operation. There are also 3 frequency converter status indicator lights in this area.

	Key	Function
10	Back	Reverts to the previous step or list in the menu structure.
11	Cancel	Cancels the last change or command as long as the display mode has not changed.
12	Info	Press for a definition of the function being displayed.
13	Navigation Keys	Use the 4 navigation keys to move between items in the menu.
14	OK	Use to access parameter groups or to enable a selection.

Table 5.3 Legend to *Illustration 5.1*, Navigation Keys

	Indicator	Light	Function
15	On	Green	The ON light activates when the frequency converter receives power from the mains voltage, a DC bus terminal, or an external 24 V supply.
16	Warn	Yellow	When warning conditions are met, the yellow WARN light comes on and text appears in the display area identifying the problem.
17	Alarm	Red	A fault condition causes the red alarm light to flash and an alarm text is displayed.

Table 5.4 Legend to *Illustration 5.1*, Indicator Lights (LEDs)

D. Operation keys and reset

Operation keys are located at the bottom of the LCP.

	Key	Function
18	Hand On	Starts the frequency converter in local control. <ul style="list-style-type: none"> An external stop signal by control input or serial communication overrides the local hand on.
19	Off	Stops the motor but does not remove power to the frequency converter.
20	Auto On	Puts the system in remote operational mode. <ul style="list-style-type: none"> Responds to an external start command by control terminals or serial communication.
21	Reset	Resets the frequency converter manually after a fault has been cleared.

Table 5.5 Legend to *Illustration 5.1, Operation Keys and Reset*

NOTICE

The display contrast can be adjusted by pressing [Status] and the [▲]/[▼] keys.

5.3.3 Parameter Settings

Establishing the correct programming for applications often requires setting functions in several related parameters. Details for parameters are provided in *chapter 9.2 Parameter Menu Structure*.

Programming data is stored internally in the frequency converter.

- For back-up, upload data into the LCP memory.
- To download data to another frequency converter, connect the LCP to that unit and download the stored settings.
- Restoring factory default settings does not change data stored in the LCP memory.

5.3.4 Uploading/Downloading Data to/from the LCP

- Press [Off] to stop the motor before uploading or downloading data.
- Press [Main Menu] *parameter 0-50 LCP Copy* and press [OK].
- Select [1] *All to LCP* to upload data to the LCP or select [2] *All from LCP* to download data from the LCP.
- Press [OK]. A progress bar shows the uploading or downloading progress.
- Press [Hand On] or [Auto On] to return to normal operation.

5.3.5 Changing Parameter Settings

Parameter settings can be accessed and changed from the Quick Menu or from the Main Menu. The Quick Menu only gives access to a limited number of parameters.

- Press [Quick Menu] or [Main Menu] on the LCP.
- Press [▲] [▼] to browse through the parameter groups, press [OK] to select a parameter group.
- Press [▲] [▼] to browse through the parameters, press [OK] to select a parameter.
- Press [▲] [▼] to change the value of a parameter setting.
- Press [◀] [▶] to shift digit when a decimal parameter is in the editing state.
- Press [OK] to accept the change.
- Press either [Back] twice to enter Status, or press [Main Menu] once to enter the Main Menu.

View changes

Quick Menu Q5 - Changes Made lists all parameters changed from default settings.

- The list only shows parameters, which have been changed in the current edit set-up.
- Parameters, which have been reset to default values, are not listed.
- The message *Empty* indicates that no parameters have been changed.

5.3.6 Restoring Default Settings

NOTICE

Risk of losing programming, motor data, localisation, and monitoring records by restoration of default settings. To provide a back-up, upload data to the LCP before initialisation.

Restoring the default parameter settings is done by initialisation of the frequency converter. Initialisation is carried out through *parameter 14-22 Operation Mode* (recommended) or manually.

- Initialisation using *parameter 14-22 Operation Mode* does not reset frequency converter settings, such as operating hours, serial communication selections, personal menu settings, fault log, alarm log, and other monitoring functions.
- Manual initialisation erases all motor, programming, localisation, and monitoring data and restores factory default settings.

Recommended initialisation procedure, via parameter 14-22 Operation Mode

1. Press [Main Menu] twice to access parameters.
2. Scroll to *parameter 14-22 Operation Mode* and press [OK].
3. Scroll to [2] *Initialisation* and press [OK].
4. Remove power to the unit and wait for the display to turn off.
5. Apply power to the unit.

Default parameter settings are restored during start-up. This may take slightly longer than normal.

6. Alarm 80 is displayed.
7. Press [Reset] to return to operation mode.

Manual initialisation procedure

1. Remove power to the unit and wait for the display to turn off.
2. Press and hold [Status], [Main Menu], and [OK] at the same time while applying power to the unit (approximately 5 s or until audible click and fan starts).

Factory default parameter settings are restored during start-up. This may take slightly longer than normal.

Manual initialisation does not reset the following frequency converter information:

- *Parameter 15-00 Operating hours.*
- *Parameter 15-03 Power Up's.*
- *Parameter 15-04 Over Temp's.*
- *Parameter 15-05 Over Volt's.*

5.4 Basic Programming

5.4.1 Commissioning with SmartStart

The SmartStart wizard enables fast configuration of basic motor and application parameters.

- SmartStart starts automatically, at first power up or after initialisation of the frequency converter.
- Follow the on-screen instructions to complete the commissioning of the frequency converter. Always reactivate SmartStart by selecting *Quick Menu Q4 - SmartStart*.
- For commissioning without use of the SmartStart wizard, refer to *chapter 5.4.2 Commissioning via [Main Menu]* or the programming guide.

NOTICE

Motor data is required for the SmartStart set-up. The required data is normally available on the motor nameplate.

The SmartStart configures the frequency converter in 3 phases, each consisting of several steps, see *Table 5.6*.

Phase		Comment
1	Basic Programming	Programme, for example motor data
2	Application Section	Select and programme appropriate application: <ul style="list-style-type: none"> • Single pump/motor. • Motor alternation. • Basic cascade control. • Master/follower.
3	Water and Pump Features	Go to water and pump dedicated parameters.

Table 5.6 SmartStart, Setup in 3 Phases

5.4.2 Commissioning via [Main Menu]

Recommended parameter settings are intended for start-up and check-out purposes. Application settings may vary.

Enter data with power ON, but before operating the frequency converter.

1. Press [Main Menu] on the LCP.
2. Press the navigation keys to scroll to parameter group *0-** Operation/Display* and press [OK].

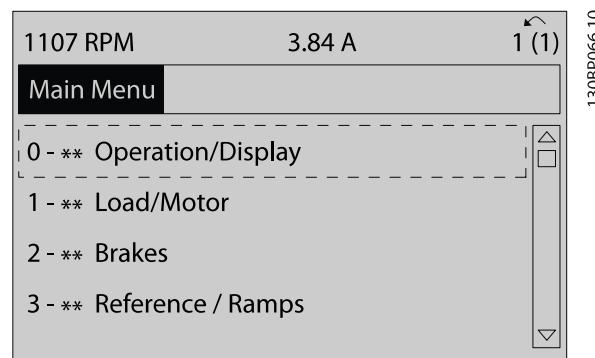

Illustration 5.2 Main Menu

- Press the navigation keys to scroll to parameter group 0-0* *Basic Settings* and press [OK].

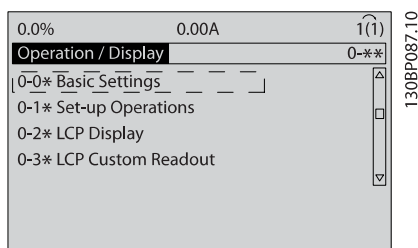

Illustration 5.3 Operation/Display

- Press the navigation keys to scroll to parameter 0-03 *Regional Settings* and press [OK].

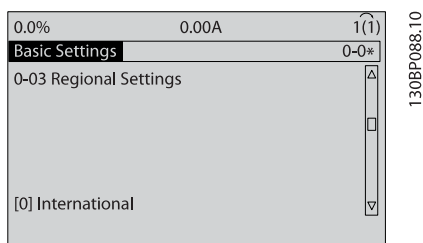

Illustration 5.4 Basic Settings

- Press the navigation keys to select [0] *International* or [1] *North America* as appropriate and press [OK]. (This changes the default settings for a number of basic parameters).
- Press [Main Menu] on the LCP.
- Press the navigation keys to scroll to parameter 0-01 *Language*.
- Select the language and press [OK].
- If a jumper wire is in place between control terminals 12 and 27, leave parameter 5-12 *Terminal 27 Digital Input* at factory default. Otherwise, select *No Operation* in parameter 5-12 *Terminal 27 Digital Input*.
- Make the application specific settings in the following parameters:
 - Parameter 3-02 *Minimum Reference*.
 - Parameter 3-03 *Maximum Reference*.
 - Parameter 3-41 *Ramp 1 Ramp Up Time*.
 - Parameter 3-42 *Ramp 1 Ramp Down Time*.
 - Parameter 3-13 *Reference Site*. Linked to Hand/Auto Local Remote.

5.4.3 Asynchronous Motor Set-up

Enter the following motor data. The information can be found on the motor nameplate.

- Parameter 1-20 *Motor Power [kW]* or parameter 1-21 *Motor Power [HP]*.
- Parameter 1-22 *Motor Voltage*.
- Parameter 1-23 *Motor Frequency*.
- Parameter 1-24 *Motor Current*.
- Parameter 1-25 *Motor Nominal Speed*.

When running in flux mode, or for optimum performance in VVC⁺ mode, extra motor data is required to set up the following parameters. The data can be found in the motor data sheet (this data is typically not available on the motor name plate). Run a complete AMA using parameter 1-29 *Automatic Motor Adaptation (AMA) [1] Enable Complete AMA* or enter the parameters manually. Parameter 1-36 *Iron Loss Resistance (Rfe)* is always entered manually.

- Parameter 1-30 *Stator Resistance (Rs)*.
- Parameter 1-31 *Rotor Resistance (Rr)*.
- Parameter 1-33 *Stator Leakage Reactance (X1)*.
- Parameter 1-34 *Rotor Leakage Reactance (X2)*.
- Parameter 1-35 *Main Reactance (Xh)*.
- Parameter 1-36 *Iron Loss Resistance (Rfe)*.

Application-specific adjustment when running VVC⁺

VVC⁺ is the most robust control mode. In most situations, it provides optimum performance without further adjustments. Run a complete AMA for best performance.

Application-specific adjustment when running Flux

Flux mode is the preferred control mode for optimum shaft performance in dynamic applications. Perform an AMA since this control mode requires precise motor data. Depending on the application, further adjustments may be required.

See Table 5.7 for application-related recommendations.

Application	Settings
Low-inertia applications	Keep calculated values.
High-inertia applications	Parameter 1-66 <i>Min. Current at Low Speed</i> . Increase current to a value between default and maximum depending on the application. Set ramp times matching the application. Too fast ramp up causes an overcurrent or overtorque. Too fast ramp down causes an overvoltage trip.

Application	Settings
High load at low speed	<i>Parameter 1-66 Min. Current at Low Speed.</i> Increase current to a value between default and maximum depending on the application.
No-load application	Adjust <i>parameter 1-18 Min. Current at No Load</i> to achieve smoother motor operation by reducing torque ripple and vibration.
Flux sensorless only	Adjust <i>parameter 1-53 Model Shift Frequency.</i> Example 1: If the motor oscillates at 5 Hz and dynamics performance is required at 15 Hz, set <i>parameter 1-53 Model Shift Frequency</i> to 10 Hz. Example 2: If the application involves dynamic load changes at low speed, reduce <i>parameter 1-53 Model Shift Frequency.</i> Observe the motor behaviour to make sure that the model shift frequency is not reduced too much. Symptoms of inappropriate model shift frequency are motor oscillations or frequency converter tripping.

Table 5.7 Recommendations for Flux Applications

5.4.4 PM Motor Setup in VVC⁺

NOTICE

Only use permanent magnet (PM) motor with fans and pumps.

Initial programming steps

1. Activate PM motor operation
Parameter 1-10 Motor Construction, select [1] PM, non salient SPM.
2. Set *parameter 0-02 Motor Speed Unit* to [0] RPM.

Programming motor data

After selecting PM motor in *parameter 1-10 Motor Construction*, the PM motor-related parameters in parameter groups 1-2* *Motor Data*, 1-3* *Adv. Motor Data* and 1-4* are active.

The necessary data can be found on the motor nameplate and in the motor data sheet.

Programme the following parameters in the listed order:

1. *Parameter 1-24 Motor Current.*
2. *Parameter 1-26 Motor Cont. Rated Torque.*
3. *Parameter 1-25 Motor Nominal Speed.*
4. *Parameter 1-39 Motor Poles.*

5. *Parameter 1-30 Stator Resistance (Rs).*
Enter line to common stator winding resistance (Rs). If only line-line data is available, divide the line-line value with 2 to achieve the line to common (starpoint) value.
6. *Parameter 1-37 d-axis Inductance (Ld).*
Enter line to common direct axis inductance of the PM motor.
If only line-line data is available, divide the line-line value by 2 to achieve the line-common (starpoint) value.
7. *Parameter 1-40 Back EMF at 1000 RPM.*
Enter line-to-line back EMF of the PM motor at 1000 RPM mechanical speed (RMS value). Back EMF is the voltage generated by a PM motor when no frequency converter is connected and the shaft is turned externally. Back EMF is normally specified for nominal motor speed or for 1000 RPM measured between 2 lines. If the value is not available for a motor speed of 1000 RPM, calculate the correct value as follows: If back EMF is for example 320 V at 1800 RPM, it can be calculated at 1000 RPM as follows: Back EMF = (Voltage / RPM)*1000 = (320/1800)*1000 = 178. This is the value that must be programmed for *parameter 1-40 Back EMF at 1000 RPM.*

Test Motor Operation

1. Start the motor at low speed (100–200 RPM). If the motor does not turn, check installation, general programming, and motor data.
2. Check if the start function in *parameter 1-70 PM Start Mode* fits the application requirements.

Rotor detection

This function is the recommended choice for applications where the motor starts from standstill, for example pumps or conveyors. On some motors, an acoustic sound is heard when the impulse is sent out. This does not harm the motor.

Parking

This function is the recommended choice for applications where the motor is rotating at slow speed, for example windmilling in fan applications. *Parameter 2-06 Parking Current* and *parameter 2-07 Parking Time* can be adjusted. Increase the factory setting of these parameters for applications with high inertia.

Start the motor at nominal speed. If the application does not run well, check the VVC⁺ PM settings. Recommendations in different applications can be found in *Table 5.7.*

Application	Settings
Low inertia applications $I_{Load}/I_{Motor} < 5$	<p><i>Parameter 1-17 Voltage filter time const.</i> to be increased by factor 5–10.</p> <p><i>Parameter 1-14 Damping Gain</i> should be reduced.</p> <p><i>Parameter 1-66 Min. Current at Low Speed</i> should be reduced (<100%).</p>
Low inertia applications $50 > I_{Load}/I_{Motor} > 5$	Keep calculated values.
High inertia applications $I_{Load}/I_{Motor} > 50$	<p><i>Parameter 1-14 Damping Gain</i>, <i>parameter 1-15 Low Speed Filter Time Const.</i>, and <i>parameter 1-16 High Speed Filter Time Const.</i> should be increased.</p>
High load at low speed <30% (rated speed)	<p><i>Parameter 1-17 Voltage filter time const.</i> should be increased.</p> <p><i>Parameter 1-66 Min. Current at Low Speed</i> should be increased (>100% for a prolonged time can overheat the motor).</p>

Table 5.8 Recommendations in Different Applications

If the motor starts oscillating at a certain speed, increase *parameter 1-14 Damping Gain*. Increase the value in small steps. Depending on the motor, a good value for this parameter can be 10% or 100% higher than the default value.

The starting torque can be adjusted in *parameter 1-66 Min. Current at Low Speed*. 100% provides nominal torque as starting torque.

5.4.5 SynRM Motor Set-up with VVC⁺

This section describes how to set up a SynRM motor with VVC⁺.

NOTICE

The SmartStart wizard covers the basic configuration of SynRM motors.

Initial programming steps

To activate SynRM motor operation, select [5] *SynC. Reluctance* in *parameter 1-10 Motor Construction*.

Programming motor data

After performing the initial programming steps, the SynRM motor-related parameters in parameter groups 1-2* *Motor Data*, 1-3* *Adv. Motor Data*, and 1-4* *Adv. Motor Data II* are active. Use the motor nameplate data and the motor data sheet to programme the following parameters in the order listed:

- *Parameter 1-23 Motor Frequency.*
- *Parameter 1-24 Motor Current.*
- *Parameter 1-25 Motor Nominal Speed.*
- *Parameter 1-26 Motor Cont. Rated Torque.*

Run a complete AMA using *parameter 1-29 Automatic Motor Adaptation (AMA) [1] Enable Complete AMA* or enter the following parameters manually:

- *Parameter 1-30 Stator Resistance (Rs).*
- *Parameter 1-37 d-axis Inductance (Ld).*
- *Parameter 1-44 d-axis Inductance Sat. (LdSat).*
- *Parameter 1-45 q-axis Inductance Sat. (LqSat).*
- *Parameter 1-48 Inductance Sat. Point.*

Application-specific adjustments

Start the motor at nominal speed. If the application does not run well, check the VVC⁺ SynRM settings. *Table 5.9* provides application-specific recommendations:

Application	Settings
Low-inertia applications $I_{Load}/I_{Motor} < 5$	Increase <i>parameter 1-17 Voltage filter time const.</i> by factor 5 to 10. Reduce <i>parameter 1-14 Damping Gain</i> . Reduce <i>parameter 1-66 Min. Current at Low Speed (<100%)</i> .
Low-inertia applications $50 > I_{Load}/I_{Motor} > 5$	Keep the default values.
High-inertia applications $I_{Load}/I_{Motor} > 50$	Increase <i>parameter 1-14 Damping Gain</i> , <i>parameter 1-15 Low Speed Filter Time Const.</i> , and <i>parameter 1-16 High Speed Filter Time Const.</i>
High-load at low speed <30% (rated speed)	Increase <i>parameter 1-17 Voltage filter time const.</i> Increase <i>parameter 1-66 Min. Current at Low Speed</i> to adjust the starting torque. 100% current provides nominal torque as starting torque. This parameter is independent of <i>parameter 30-20 High Starting Torque Time [s]</i> and <i>parameter 30-21 High Starting Torque Current [%]</i> . Working at a current level higher than 100% for a prolonged time can cause the motor to overheat.
Dynamic applications	Increase <i>parameter 14-41 AEO Minimum Magnetisation</i> for highly dynamic applications. Adjusting <i>parameter 14-41 AEO Minimum Magnetisation</i> ensures a good balance between energy efficiency and dynamics. Adjust <i>parameter 14-42 Minimum AEO Frequency</i> to specify the minimum frequency at which the frequency converter should use minimum magnetisation.

Table 5.9 Recommendations for Various Applications

If the motor starts oscillating at a certain speed, increase *parameter 1-14 Damping Gain*. Increase the damping gain value in small steps. Depending on the motor, this parameter can be set to 10–100% higher than the default value.

5.4.6 Automatic Energy Optimisation (AEO)

NOTICE

AEO is not relevant for permanent magnet motors.

AEO is a procedure which minimises voltage to the motor, thereby reducing energy consumption, heat, and noise.

To activate AEO, set *parameter 1-03 Torque Characteristics* to [2] *Auto Energy Optim. CT* or [3] *Auto Energy Optim. VT*.

5.4.7 Automatic Motor Adaptation (AMA)

AMA is a procedure which optimises compatibility between the frequency converter and the motor.

- The frequency converter builds a mathematical model of the motor for regulating output motor current. The procedure also tests the input phase balance of electrical power. It compares the motor characteristics with the entered nameplate data.
- The motor shaft does not turn and no harm is done to the motor while running the AMA.
- Some motors may be unable to run the complete version of the test. In that case, select [2] *Enable reduced AMA*.
- If an output filter is connected to the motor, select [2] *Enable reduced AMA*.
- If warnings or alarms occur, see *chapter 7.4 List of Warnings and Alarms*.
- Run this procedure on a cold motor for best results.

To run AMA

1. Press [Main Menu] to access parameters.
2. Scroll to parameter group 1-** *Load and Motor* and press [OK].
3. Scroll to parameter group 1-2* *Motor Data* and press [OK].
4. Scroll to *parameter 1-29 Automatic Motor Adaptation (AMA)* and press [OK].
5. Select [1] *Enable complete AMA* and press [OK].
6. Follow the on-screen instructions.
7. The test runs automatically and indicates when it is complete.
8. The advanced motor data is entered in parameter group 1-3* *Adv. Motor Data*.

5.5 Checking Motor Rotation

NOTICE

Risk of damage to pumps/compressors caused by motor running in wrong direction. Before running the frequency converter, check the motor rotation.

The motor runs briefly at 5 Hz or the minimum frequency set in *parameter 4-12 Motor Speed Low Limit [Hz]*.

Commissioning

1. Press [Main Menu].
2. Scroll to *parameter 1-28 Motor Rotation Check* and press [OK].
3. Scroll to *[1] Enable*.

The following text appears: *Note! Motor may run in wrong direction.*

4. Press [OK].
5. Follow the on-screen instructions.

NOTICE

To change the direction of rotation, remove power to the frequency converter and wait for power to discharge.

Reverse the connection of any 2 of the 3 motor wires on the motor or frequency converter side of the connection.

5

5.6 Local-control Test

1. Press [Hand On] to provide a local start command to the frequency converter.
2. Accelerate the frequency converter by pressing [▲] to full speed. Moving the cursor left of the decimal point provides quicker input changes.
3. Note any acceleration problems.
4. Press [Off]. Note any deceleration problems.

In the event of acceleration or deceleration problems, see *chapter 7.5 Troubleshooting*. See *chapter 7.4 List of Warnings and Alarms* for resetting the frequency converter after a trip.

5.7 System Start-up

The procedure in this section requires user-wiring and application programming to be completed. The following procedure is recommended after application set-up is completed.

1. Press [Auto On].
2. Apply an external run command.
3. Adjust the speed reference throughout the speed range.
4. Remove the external run command.
5. Check the sound and vibration levels of the motor to ensure that the system is working as intended.

If warnings or alarms occur, see *chapter 7.3 Warning and Alarm Types* or *chapter 7.4 List of Warnings and Alarms*.

6 Application Set-up Examples

The examples in this section are intended as a quick reference for common applications.

- Parameter settings are the regional default values unless otherwise indicated (selected in *parameter 0-03 Regional Settings*).
- Parameters associated with the terminals and their settings are shown next to the drawings.
- Required switch settings for analog terminals A53 or A54 are also shown.

NOTICE

When using the optional STO feature, a jumper wire may be required between terminal 12 (or 13) and terminal 37 for the frequency converter to operate with factory default programming values.

6

6.1 Application Examples

6.1.1 Feedback

		Parameters	
FC		Function	Setting
+24 V	12	Parameter 6-22 Terminal 54 Low Current	4 mA*
+24 V	13	Parameter 6-23 Terminal 54 High Current	20 mA*
D IN	18	Parameter 6-24 Terminal 54 Low Ref./Feedb. Value	0*
D IN	19	Parameter 6-25 Terminal 54 High Ref./Feedb. Value	50*
COM	20	* = Default value	
D IN	27	Notes/comments: D IN 37 is an option.	
D IN	29		
D IN	32		
D IN	33		
D IN	37		
+10 V	50		
A IN	53		
A IN	54		
COM	55		
A OUT	42		
COM	39		

Table 6.1 Analog Current Feedback Transducer

		Parameters	
FC		Function	Setting
+24 V	12	Parameter 6-20 Terminal 54 Low Voltage	0.07 V*
+24 V	13	Parameter 6-21 Terminal 54 High Voltage	10 V*
D IN	18	Parameter 6-24 Terminal 54 Low Ref./Feedb. Value	0*
D IN	19	Parameter 6-25 Terminal 54 High Ref./Feedb. Value	50*
COM	20	* = Default value	
D IN	27	Notes/comments: D IN 37 is an option.	
D IN	29		
D IN	32		
D IN	33		
D IN	37		
+10 V	50		
A IN	53		
A IN	54		
COM	55		
A OUT	42		
COM	39		

Table 6.2 Analog Voltage Feedback Transducer (3-wire)

		Parameters	
FC		Function	Setting
+24 V	12	Parameter 6-20 Terminal 54 Low Voltage	0.07 V*
+24 V	13	Parameter 6-21 Terminal 54 High Voltage	10 V*
D IN	18	Parameter 6-24 Terminal 54 Low Ref./Feedb. Value	0*
D IN	19	Parameter 6-25 Terminal 54 High Ref./Feedb. Value	50*
COM	20	* = Default value	
D IN	27	Notes/comments: D IN 37 is an option.	
D IN	29		
D IN	32		
D IN	33		
D IN	37		
+10 V	50		
A IN	53		
A IN	54		
COM	55		
A OUT	42		
COM	39		

Table 6.3 Analog Voltage Feedback Transducer (4-wire)

6.1.2 Speed

		Parameters	
FC		Function	Setting
+24 V	12	130BB926.10	Parameter 6-10 Terminal 53 Low Voltage
+24 V	13		0.07 V*
D IN	18		Parameter 6-11 Terminal 53 High Voltage
D IN	19		10 V*
COM	20		Parameter 6-14 Terminal 53 Low Ref./Feedb. Value
D IN	27		0 Hz
D IN	29		Parameter 6-15 Terminal 53 High Ref./Feedb. Value
D IN	32		50 Hz
D IN	33		* = Default value
D IN	37		Notes/comments: D IN 37 is an option.
+10 V	50		
A IN	53		
A IN	54		
COM	55		
A OUT	42		
COM	39		

Table 6.4 Analog Speed Reference (Voltage)

		Parameters	
FC		Function	Setting
+24 V	12	130BB927.10	Parameter 6-12 Terminal 53 Low Current
+24 V	13		4 mA*
D IN	18		Parameter 6-13 Terminal 53 High Current
D IN	19		20 mA*
COM	20		Parameter 6-14 Terminal 53 Low Ref./Feedb. Value
D IN	27		0 Hz
D IN	29		Parameter 6-15 Terminal 53 High Ref./Feedb. Value
D IN	32		50 Hz
D IN	33		* = Default value
D IN	37		Notes/comments: D IN 37 is an option.
+10 V	50		
A IN	53		
A IN	54		
COM	55		
A OUT	42		
COM	39		

Table 6.5 Analog Speed Reference (Current)

		Parameters	
FC		Function	Setting
+24 V	12	130BB683.10	Parameter 6-10 Terminal 53 Low Voltage
+24 V	13		0.07 V*
D IN	18		Parameter 6-11 Terminal 53 High Voltage
D IN	19		10 V*
COM	20		Parameter 6-14 Terminal 53 Low Ref./Feedb. Value
D IN	27		0 Hz
D IN	29		Parameter 6-15 Terminal 53 High Ref./Feedb. Value
D IN	32		50 Hz
D IN	33		* = Default value
D IN	37		Notes/comments: D IN 37 is an option.
+10 V	50		
A IN	53		
A IN	54		
COM	55		
A OUT	42		
COM	39		

Table 6.6 Speed Reference (Using a Manual Potentiometer)

6.1.3 Run/Stop

		Parameters	
FC		Function	Setting
+24 V	12	130BB680.10	Parameter 5-10 Terminal 18 Digital Input
+24 V	13		[8] Start*
D IN	18		Parameter 5-12 Terminal 27 Digital Input
D IN	19		[7] External interlock
COM	20		* = Default value
D IN	27		Notes/comments: D IN 37 is an option.
D IN	29		
D IN	32		
D IN	33		
D IN	37		
+10 V	50		
A IN	53		
A IN	54		
COM	55		
A OUT	42		
COM	39		

Table 6.7 Run/Stop Command with External Interlock

		Parameters	
FC		Function	Setting
+24 V	12	Parameter 5-10 Terminal 18 Digital Input	[8] Start*
+24 V	13		
D IN	18	Parameter 5-12 Terminal 27 Digital Input	[7] External interlock
D IN	19		
COM	20	* = Default value	
D IN	27	Notes/comments: If parameter 5-12 Terminal 27 Digital Input is set to [0] no operation, a jumper wire to terminal 27 is not needed. D IN 37 is an option.	
D IN	29		
D IN	32		
D IN	33		
D IN	37		
+10 V	50		
A IN	53		
A IN	54		
COM	55		
A OUT	42		
COM	39		
R1	01		
	02		
	03		
R2	04		
	05		
	06		

Table 6.8 Run/Stop Command without External Interlock

6.1.4 External Alarm Reset

		Parameters	
FC		Function	Setting
+24 V	12	Parameter 5-11 Terminal 19 Digital Input	[1] Reset
+24 V	13		
D IN	18	* = Default Value	
D IN	19	Notes/comments: D IN 37 is an option.	
COM	20		
D IN	27		
D IN	29		
D IN	32		
D IN	33		
D IN	37		
+10 V	50		
A IN	53		
A IN	54		
COM	55		
A OUT	42		
COM	39		

Table 6.10 External Alarm Reset

		Parameters	
FC		Function	Setting
+24 V	12	Parameter 5-10 Terminal 18 Digital Input	[8] Start*
+24 V	13		
D IN	18	Parameter 5-11 Terminal 19 Digital Input	[52] Run Permissive
D IN	19		
COM	20	Parameter 5-12 Terminal 27 Digital Input	[7] External interlock
D IN	27		
D IN	29	Parameter 5-40 Function Relay	[167] Start command act.
D IN	32		
D IN	33	* = Default value	
D IN	37	Notes/comments: D IN 37 is an option.	
+10 V	50		
A IN	53		
A IN	54		
COM	55		
A OUT	42		
COM	39		
R1	01		
	02		
	03		
R2	04		
	05		
	06		

Table 6.9 Run Permissive

6.1.5 RS485

		Parameters																																																													
		Function	Setting																																																												
<table border="1"> <thead> <tr> <th colspan="2">FC</th> </tr> </thead> <tbody> <tr><td>+24 V</td><td>12</td></tr> <tr><td>+24 V</td><td>13</td></tr> <tr><td>D IN</td><td>18</td></tr> <tr><td>D IN</td><td>19</td></tr> <tr><td>COM</td><td>20</td></tr> <tr><td>D IN</td><td>27</td></tr> <tr><td>D IN</td><td>29</td></tr> <tr><td>D IN</td><td>32</td></tr> <tr><td>D IN</td><td>33</td></tr> <tr><td>D IN</td><td>37</td></tr> <tr><td colspan="2"> </td></tr> <tr><td>+10 V</td><td>50</td></tr> <tr><td>A IN</td><td>53</td></tr> <tr><td>A IN</td><td>54</td></tr> <tr><td>COM</td><td>55</td></tr> <tr><td>A OUT</td><td>42</td></tr> <tr><td>COM</td><td>39</td></tr> <tr><td colspan="2"> </td></tr> <tr><td>R1</td><td>01</td></tr> <tr><td></td><td>02</td></tr> <tr><td></td><td>03</td></tr> <tr><td colspan="2"> </td></tr> <tr><td>R2</td><td>04</td></tr> <tr><td></td><td>05</td></tr> <tr><td></td><td>06</td></tr> <tr><td colspan="2"> </td></tr> <tr><td></td><td>61</td></tr> <tr><td></td><td>68</td></tr> <tr><td></td><td>69</td></tr> </tbody> </table>		FC		+24 V	12	+24 V	13	D IN	18	D IN	19	COM	20	D IN	27	D IN	29	D IN	32	D IN	33	D IN	37			+10 V	50	A IN	53	A IN	54	COM	55	A OUT	42	COM	39			R1	01		02		03			R2	04		05		06				61		68		69	130B8685.10	Parameter 8-30 Protocol FC*
FC																																																															
+24 V	12																																																														
+24 V	13																																																														
D IN	18																																																														
D IN	19																																																														
COM	20																																																														
D IN	27																																																														
D IN	29																																																														
D IN	32																																																														
D IN	33																																																														
D IN	37																																																														
+10 V	50																																																														
A IN	53																																																														
A IN	54																																																														
COM	55																																																														
A OUT	42																																																														
COM	39																																																														
R1	01																																																														
	02																																																														
	03																																																														
R2	04																																																														
	05																																																														
	06																																																														
	61																																																														
	68																																																														
	69																																																														
		Parameter 8-31 Address	1*																																																												
		Parameter 8-32 Baud Rate	9600*																																																												
		* = Default Value																																																													
		Notes/comments: Select protocol, address and baud rate in the above mentioned parameters. D IN 37 is an option.																																																													

Table 6.11 RS485 Network Connection

6.1.6 Motor Thermistor



THERMISTOR INSULATION

Risk of personal injury or equipment damage.

- Use only thermistors with reinforced or double insulation to meet PELV insulation requirements.

		Parameters																																													
		Function	Setting																																												
<table border="1"> <thead> <tr> <th colspan="2">VLT</th> </tr> </thead> <tbody> <tr><td>+24 V</td><td>12</td></tr> <tr><td>+24 V</td><td>13</td></tr> <tr><td>D IN</td><td>18</td></tr> <tr><td>D IN</td><td>19</td></tr> <tr><td>COM</td><td>20</td></tr> <tr><td>D IN</td><td>27</td></tr> <tr><td>D IN</td><td>29</td></tr> <tr><td>D IN</td><td>32</td></tr> <tr><td>D IN</td><td>33</td></tr> <tr><td>D IN</td><td>37</td></tr> <tr><td colspan="2"> </td></tr> <tr><td>+10 V</td><td>50</td></tr> <tr><td>A IN</td><td>53</td></tr> <tr><td>A IN</td><td>54</td></tr> <tr><td>COM</td><td>55</td></tr> <tr><td>A OUT</td><td>42</td></tr> <tr><td>COM</td><td>39</td></tr> <tr><td colspan="2"> </td></tr> <tr><td></td><td>61</td></tr> <tr><td></td><td>68</td></tr> <tr><td></td><td>69</td></tr> </tbody> </table>		VLT		+24 V	12	+24 V	13	D IN	18	D IN	19	COM	20	D IN	27	D IN	29	D IN	32	D IN	33	D IN	37			+10 V	50	A IN	53	A IN	54	COM	55	A OUT	42	COM	39				61		68		69	130B8686.12	Parameter 1-90 <i>Motor Thermal Protection</i> [2] Thermistor trip
VLT																																															
+24 V	12																																														
+24 V	13																																														
D IN	18																																														
D IN	19																																														
COM	20																																														
D IN	27																																														
D IN	29																																														
D IN	32																																														
D IN	33																																														
D IN	37																																														
+10 V	50																																														
A IN	53																																														
A IN	54																																														
COM	55																																														
A OUT	42																																														
COM	39																																														
	61																																														
	68																																														
	69																																														
		Parameter 1-93 T Thermistor Source	[1] Analog input 53																																												
		* = Default Value																																													
		Notes/comments: If only a warning is desired, parameter 1-90 <i>Motor Thermal Protection</i> should be set to [1] <i>Thermistor warning</i> . D IN 37 is an option.																																													

Table 6.12 Motor Thermistor

7 Maintenance, Diagnostics and Troubleshooting

This chapter includes maintenance and service guidelines, status messages, warnings and alarms, and basic troubleshooting.

7.1 Maintenance and Service

Under normal operating conditions and load profiles, the frequency converter is maintenance-free throughout its designed lifetime. To prevent breakdown, danger, and damage, examine the frequency converter at regular intervals depending on the operating conditions. Replace worn or damaged parts with original spare parts or standard parts.

⚠ WARNING

UNINTENDED START

When the frequency converter is connected to AC mains, DC power supply, or load sharing, the motor may start at any time. Unintended start during programming, service, or repair work can result in death, serious injury, or property damage. The motor can start by means of an external switch, a serial bus command, an input reference signal from the LCP or LOP, via remote operation using MCT 10 Set-up Software, or after a cleared fault condition.

7.2 Status Messages

When the frequency converter is in *Status mode*, status messages are generated automatically and appear in the bottom line of the display (see *Illustration 7.1*).

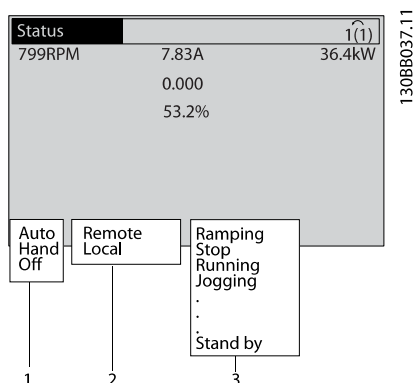

1	Operation mode (see <i>Table 7.1</i>)
2	Reference site (see <i>Table 7.2</i>)
3	Operation status (see <i>Table 7.3</i>)

Illustration 7.1 Status Display

Table 7.1 to *Table 7.3* describe the displayed status messages.

Off	The frequency converter does not react to any control signal until [Auto On] or [Hand On] is pressed.
Auto On	The frequency converter is controlled from the control terminals and/or the serial communication.
Hand On	The frequency converter is controlled by the navigation keys on the LCP. Stop commands, reset, reversing, DC brake, and other signals applied to the control terminals override local control.

Table 7.1 Operation Mode

Remote	The speed reference is given from external signals, serial communication, or internal preset references.
Local	The frequency converter uses [Hand On] control or reference values from the LCP.

Table 7.2 Reference Site

AC Brake	AC Brake was selected in <i>parameter 2-10 Brake Function</i> . The AC brake overmagnetises the motor to achieve a controlled slow-down.
AMA finish OK	Automatic motor adaptation (AMA) was carried out successfully.
AMA ready	AMA is ready to start. Press [Hand On] to start.
AMA running	AMA process is in progress.
Braking	The brake chopper is in operation. Generative energy is absorbed by the brake resistor.
Braking max.	The brake chopper is in operation. The power limit for the brake resistor defined in <i>parameter 2-12 Brake Power Limit (kW)</i> has been reached.
Coast	<ul style="list-style-type: none"> Coast inverse was selected as a function for a digital input (parameter group 5-1* <i>Digital Inputs</i>). The corresponding terminal is not connected. Coast activated by serial communication.
Ctrl. ramp-down	<p>[1] <i>Control Ramp-down</i> was selected in <i>parameter 14-10 Mains Failure</i>.</p> <ul style="list-style-type: none"> The mains voltage is below the value set in <i>parameter 14-11 Mains Voltage at Mains Fault</i> at mains fault The frequency converter ramps down the motor using a controlled ramp down.

Current High	The frequency converter output current is above the limit set in <i>parameter 4-51 Warning Current High</i> .
Current Low	The frequency converter output current is below the limit set in <i>parameter 4-52 Warning Speed Low</i> .
DC Hold	[1] <i>DC hold</i> is selected in <i>parameter 1-80 Function at Stop</i> and a stop command is active. The motor is held by a DC current set in <i>parameter 2-00 DC Hold/Preheat Current</i> .
DC Stop	The motor is held with a DC current (<i>parameter 2-01 DC Brake Current</i>) for a specified time (<i>parameter 2-02 DC Braking Time</i>). <ul style="list-style-type: none"> The <i>DC Brake</i> cut in speed is reached in <i>parameter 2-03 DC Brake Cut In Speed [RPM]</i> and a stop command is active. <i>DC Brake</i> (inverse) is selected as a function for a digital input (parameter group 5-1* <i>Digital Inputs</i>). The corresponding terminal is not active. The <i>DC Brake</i> is activated via serial communication.
Feedback high	The sum of all active feedbacks is above the feedback limit set in <i>parameter 4-57 Warning Feedback High</i> .
Feedback low	The sum of all active feedbacks is below the feedback limit set in <i>parameter 4-56 Warning Feedback Low</i> .
Freeze output	The remote reference is active, which holds the present speed. <ul style="list-style-type: none"> <i>Freeze output</i> was selected as a function for a digital input (parameter group 5-1* <i>Digital Inputs</i>). The corresponding terminal is active. Speed control is only possible via the terminal functions <i>Speed Up</i> and <i>Speed Down</i>. <i>Hold ramp</i> is activated via serial communication.
Freeze output request	A freeze output command was given, but the motor remains stopped until a run permissive signal is received.
Freeze ref.	<i>Freeze Reference</i> was selected as a function for a digital input (parameter group 5-1* <i>Digital Inputs</i>). The corresponding terminal is active. The frequency converter saves the actual reference. Changing the reference is now only possible via terminal functions <i>Speed Up</i> and <i>Speed Down</i> .
Jog request	A jog command was given, but the motor remains stopped until a run permissive signal is received via a digital input.

Jogging	The motor is running as programmed in <i>parameter 3-19 Jog Speed [RPM]</i> . <ul style="list-style-type: none"> <i>Jog</i> was selected as a function for a digital input (parameter group 5-1* <i>Digital Inputs</i>). The corresponding terminal (for example Terminal 29) is active. The <i>Jog</i> function is activated via the serial communication. The <i>Jog</i> function was selected as a reaction for a monitoring function (for example No signal). The monitoring function is active.
Motor check	In <i>parameter 1-80 Function at Stop</i> , [2] <i>Motor Check</i> was selected. A stop command is active. To ensure that a motor is connected to the frequency converter, a permanent test current is applied to the motor.
OVC control	Overvoltage control was activated in <i>parameter 2-17 Over-voltage Control</i> , [2] <i>Enabled</i> . The connected motor supplies the frequency converter with generative energy. The overvoltage control adjusts the V/Hz ratio to run the motor in controlled mode and to prevent the frequency converter from tripping.
PowerUnit Off	(Only frequency converters with an external 24 V power supply installed). Mains supply to the frequency converter was removed, and the control card is supplied by the external 24 V.
Protection md	Protection mode is active. The unit has detected a critical status (overcurrent or overvoltage). <ul style="list-style-type: none"> To avoid tripping, switching frequency is reduced to 4 kHz. If possible, protection mode ends after approximately 10 s. Protection mode can be restricted in <i>parameter 14-26 Trip Delay at Inverter Fault</i>.
QStop	The motor is decelerating using <i>parameter 3-81 Quick Stop Ramp Time</i> . <ul style="list-style-type: none"> <i>Quick stop inverse</i> was selected as a function for a digital input (parameter group 5-1* <i>Digital Inputs</i>). The corresponding terminal is not active. The <i>quick stop</i> function was activated via serial communication.
Ramping	The motor is accelerating/decelerating using the active ramp up/down. The reference, a limit value, or a standstill is not yet reached.
Ref. high	The sum of all active references is above the reference limit set in <i>parameter 4-55 Warning Reference High</i> .

Ref. low	The sum of all active references is below the reference limit set in <i>parameter 4-54 Warning Reference Low</i> .
Run on ref.	The frequency converter is running in the reference range. The feedback value matches the setpoint value.
Run request	A start command was given, but the motor remains stopped until a run permissive signal is received via digital input.
Running	The motor is driven by the frequency converter.
Sleep Mode	The energy-saving function is enabled. The motor has stopped, but restarts automatically when required.
Speed high	Motor speed is above the value set in <i>parameter 4-53 Warning Speed High</i> .
Speed low	Motor speed is below the value set in <i>parameter 4-52 Warning Speed Low</i> .
Standby	In <i>Auto On</i> mode, the frequency converter starts the motor with a start signal from a digital input or serial communication.
Start delay	In <i>parameter 1-71 Start Delay</i> , a delay starting time was set. A start command is activated and the motor starts after the start delay time expires.
Start fwd/rev	<i>Start forward</i> and <i>start reverse</i> were selected as functions for 2 different digital inputs (parameter group <i>5-1* Digital Inputs</i>). The motor starts in forward or reverse direction depending on which corresponding terminal is activated.
Stop	The frequency converter has received a stop command from the LCP, digital input, or serial communication.
Trip	An alarm occurred and the motor is stopped. Once the cause of the alarm is cleared, the frequency converter can be reset manually by pressing [Reset] or remotely by control terminals or serial communication.
Trip lock	An alarm occurred and the motor is stopped. Once the cause of the alarm is cleared, power must be cycled to the frequency converter. The frequency converter can then be reset manually by pressing [Reset], or remotely by control terminals or serial communication.

Table 7.3 Operation Status

NOTICE

In auto/remote mode, the frequency converter requires external commands to execute functions.

7.3 Warning and Alarm Types

Warnings

A warning is issued when an alarm condition is impending or when an abnormal operating condition is present and may result in the frequency converter issuing an alarm. A warning clears by itself when the abnormal condition ceases.

Alarms

Trip

An alarm is issued when the frequency converter is tripped, meaning that the frequency converter suspends operation to prevent frequency converter or system damage. The motor coasts to a stop. The frequency converter logic continues to operate and monitor the frequency converter status. After the fault condition is remedied, the frequency converter can be reset. It is then ready to start operation again.

Resetting the frequency converter after trip/trip lock

A trip can be reset in any of 4 ways:

- Press [Reset] on the LCP.
- Digital reset input command.
- Serial communication reset input command.
- Auto reset.

Trip lock

Input power is cycled. The motor coasts to a stop. The frequency converter continues to monitor the frequency converter status. Remove input power to the frequency converter, correct the cause of the fault, and reset the frequency converter.

Warning and alarm displays

- A warning is displayed in the LCP along with the warning number.
- An alarm flashes along with the alarm number.

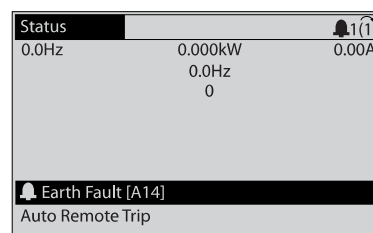

1308P086.11

Illustration 7.2 Alarm Display Example

In addition to the text and alarm code in the LCP, there are 3 status indicator lights.

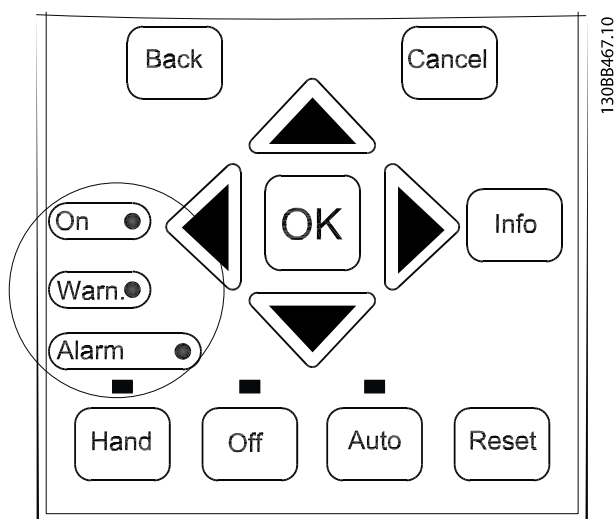

	Warning indicator light	Alarm indicator light
Warning	On	Off
Alarm	Off	On (Flashing)
Trip-Lock	On	On (Flashing)

Illustration 7.3 Status Indicator Lights

7.4 List of Warnings and Alarms

The warning/alarm information in this chapter defines each warning/alarm condition, provides the probable cause for the condition, and details a remedy or troubleshooting procedure.

WARNING 1, 10 Volts low

The control card voltage from terminal 50 is <10 V. Remove some of the load from terminal 50, as the 10 V supply is overloaded. Maximum 15 mA or minimum 590 Ω.

A short circuit in a connected potentiometer or improper wiring of the potentiometer can cause this condition.

Troubleshooting

- Remove the wiring from terminal 50.
- If the warning clears, the problem is with the customer wiring.
- If the warning does not clear, replace the control card.

WARNING/ALARM 2, Live zero error

This warning or alarm only appears if programmed in *parameter 6-01 Live Zero Timeout Function*. The signal on one of the analog inputs is less than 50% of the minimum value programmed for that input. Broken wiring or signals being sent by a faulty device causes this condition.

Troubleshooting

- Check connections on all the analog input terminals. Control card terminals 53 and 54 for signals, terminal 55 common. MCB 101 terminals 11 and 12 for signals, terminal 10 common. MCB 109 terminals 1, 3, 5 for signals, terminals 2, 4, 6 common).
- Check that the frequency converter programming and switch settings match the analog signal type.
- Perform an input terminal signal test.

WARNING/ALARM 3, No motor

No motor has been connected to the output of the frequency converter.

WARNING/ALARM 4, Mains phase loss

A phase is missing on the supply side, or the mains voltage imbalance is too high. This message also appears in case of a fault in the input rectifier on the frequency converter. Options are programmed in *parameter 14-12 Function at Mains Imbalance*.

Troubleshooting

- Check the supply voltage and supply currents to the frequency converter.

WARNING 5, DC link voltage high

The intermediate circuit voltage (DC) is higher than the high-voltage warning limit. The limit depends on the frequency converter voltage rating. The unit is still active.

WARNING 6, DC link voltage low

The intermediate circuit voltage (DC) is lower than the low-voltage warning limit. The limit depends on the frequency converter voltage rating. The unit is still active.

WARNING/ALARM 7, DC overvoltage

If the intermediate circuit voltage exceeds the limit, the frequency converter trips after some time.

Troubleshooting

- Connect a brake resistor.
- Extend the ramp time.
- Change the ramp type.
- Activate the functions in *parameter 2-10 Brake Function*.
- Increase *parameter 14-26 Trip Delay at Inverter Fault*.

WARNING/ALARM 8, DC under voltage

If the intermediate circuit voltage (DC link) drops below the undervoltage limit, the frequency converter checks if a 24 V DC back-up supply is connected. If no 24 V DC back-up supply is connected, the frequency converter trips after a fixed time delay. The time delay varies with unit size.

Troubleshooting

- Check that the supply voltage matches the frequency converter voltage.
- Perform an input voltage test.

- Perform a soft charge circuit test.

WARNING/ALARM 9, Inverter overload

The frequency converter is about to cut out because of an overload (too high current for too long). The counter for electronic thermal inverter protection issues a warning at 98% and trips at 100%, while issuing an alarm. The frequency converter *cannot* be reset until the counter is below 90%.

Troubleshooting

- Compare the output current shown on the LCP with the frequency converter rated current.
- Compare the output current shown on the LCP with measured motor current.
- Display the thermal drive load on the LCP and monitor the value. When running above the frequency converter continuous current rating, the counter should increase. When running below the frequency converter continuous current rating, the counter should decrease.

WARNING/ALARM 10, Motor overload temperature

According to the electronic thermal protection (ETR), the motor is too hot. Select whether the frequency converter issues a warning or an alarm when the counter reaches 100% in *parameter 1-90 Motor Thermal Protection*. The fault occurs when the motor overload exceeds 100% for too long.

Troubleshooting

- Check for motor overheating.
- Check if the motor is mechanically overloaded.
- Check that the motor current set in *parameter 1-24 Motor Current* is correct.
- Ensure the motor data in parameters 1-20 through 1-25 is set correctly.
- If an external fan is used, check that it is selected in *parameter 1-91 Motor External Fan*.
- Running AMA in *parameter 1-29 Automatic Motor Adaptation (AMA)* tunes the frequency converter to the motor more accurately and reduces thermal loading.

WARNING/ALARM 11, Motor thermistor overtemp

The thermistor might be disconnected. Select whether the frequency converter issues a warning or an alarm in *parameter 1-90 Motor Thermal Protection*.

Troubleshooting

- Check for motor overheating.
- Check if the motor is mechanically overloaded.
- Check that the thermistor is connected correctly between either terminal 53 or 54 (analog voltage input) and terminal 50 (+10 V supply) and that the terminal switch for 53 or 54 is set for voltage.

Check *parameter 1-93 Thermistor Source* selects terminal 53 or 54.

- When using digital inputs 18 or 19, check that the thermistor is connected correctly between either terminal 18 or 19 (digital input PNP only) and terminal 50.
- If a KTY sensor is used, check for correct connection between terminals 54 and 55.
- If using a thermal switch or thermistor, check that the programming if *parameter 1-93 Thermistor Source* matches sensor wiring.
- If using a KTY sensor, check the programming of *parameter 1-95 KTY Sensor Type*, and *parameter 1-97 KTY Threshold level* match sensor wiring.

WARNING/ALARM 12, Torque limit

The torque has exceeded the value in *parameter 4-16 Torque Limit Motor Mode* or the value in *parameter 4-17 Torque Limit Generator Mode*. *Parameter 14-25 Trip Delay at Torque Limit* can change this from a warning-only condition to a warning followed by an alarm.

Troubleshooting

- If the motor torque limit is exceeded during ramp-up, extend the ramp-up time.
- If the generator torque limit is exceeded during ramp down, extend the ramp-down time.
- If torque limit occurs while running, possibly increase the torque limit. Be sure that the system can operate safely at a higher torque.
- Check the application for excessive current draw on the motor.

WARNING/ALARM 13, Over current

The inverter peak current limit (approximately 200% of the rated current) is exceeded. The warning lasts about 1.5 s, then the frequency converter trips and issues an alarm. Shock loading or fast acceleration with high-inertia loads can cause this fault. If extended mechanical brake control is selected, the trip can be reset externally.

Troubleshooting

- Remove power and check if the motor shaft can be turned.
- Check that the motor size matches the frequency converter.
- Check parameters 1-20 to 1-25 for correct motor data.

ALARM 14, Earth (ground) fault

There is current from the output phases to ground, either in the cable between the frequency converter and the motor or in the motor itself.

Troubleshooting

- Remove power from the frequency converter and repair the ground fault.
- Check for ground faults in the motor by measuring the resistance to ground of the motor leads and the motor with a megohmmeter.
- Perform current sensor test.

ALARM 15, Hardware mismatch

A fitted option is not operational with the present control board hardware or software.

Record the value of the following parameters and contact the local KSB supplier:

- *Parameter 15-40 FC Type.*
- *Parameter 15-41 Power Section.*
- *Parameter 15-42 Voltage.*
- *Parameter 15-43 Software Version.*
- *Parameter 15-45 Actual Typecode String.*
- *Parameter 15-49 SW ID Control Card.*
- *Parameter 15-50 SW ID Power Card.*
- *Parameter 15-60 Option Mounted.*
- *Parameter 15-61 Option SW Version (for each option slot).*

ALARM 16, Short circuit

There is short-circuiting in the motor or motor wiring.

Troubleshooting

- Remove power from the frequency converter and repair the short circuit.

WARNING/ALARM 17, Control word timeout

There is no communication to the frequency converter. The warning is only active when *parameter 8-04 Control Word Timeout Function* is NOT set to [0] Off.

If *parameter 8-04 Control Word Timeout Function* is set to [5] Stop and trip, a warning appears and the frequency converter ramps down until it trips, then it displays an alarm.

Troubleshooting

- Check the connections on the serial communication cable.
- Increase *parameter 8-03 Control Word Timeout Time*.
- Check the operation of the communication equipment.
- Verify a proper installation based on EMC requirements.

WARNING/ALARM 22, Hoist mechanical brake

When this warning is active, the LCP shows the type of issue.

0 = The torque ref. was not reached before timeout.

1 = There was no brake feedback before timeout.

WARNING 23, Internal fan fault

The fan warning function is an extra protective function that checks if the fan is running/mounted. The fan warning can be disabled in *parameter 14-53 Fan Monitor ([0] Disabled)*.

Troubleshooting

- Check the fan resistance.
- Check the soft charge fuses.

WARNING 24, External fan fault

The fan warning function is an extra protective function that checks if the fan is running/mounted. The fan warning can be disabled in *parameter 14-53 Fan Monitor ([0] Disabled)*.

Troubleshooting

- Check the fan resistance.
- Check the soft charge fuses.

WARNING 25, Brake resistor short circuit

The brake resistor is monitored during operation. If a short circuit occurs, the brake function is disabled and the warning appears. The frequency converter is still operational but without the brake function. Remove power from the frequency converter and replace the brake resistor (see *parameter 2-15 Brake Check*).

WARNING/ALARM 26, Brake resistor power limit

The power transmitted to the brake resistor is calculated as a mean value over the last 120 s of run time. The calculation is based on the intermediate circuit voltage and the brake resistance value set in *parameter 2-16 AC brake Max. Current*. The warning is active when the dissipated braking is higher than 90% of the brake resistance power. If [2] Trip is selected in *parameter 2-13 Brake Power Monitoring*, the frequency converter trips when the dissipated braking power reaches 100%.

WARNING/ALARM 27, Brake chopper fault

The brake transistor is monitored during operation. If a short circuit occurs, the brake function is disabled and a warning is issued. The frequency converter is still operational, but since the brake transistor has short-circuited, substantial power is transmitted to the brake resistor, even if it is inactive.

Remove power from the frequency converter and remove the brake resistor.

This alarm/warning could also occur if the brake resistor overheats. Terminals 104 and 106 are available as brake resistor Klixon inputs, see *Brake Resistor Temperature Switch* in the design guide.

WARNING/ALARM 28, Brake check failed

The brake resistor is not connected or not working. Check *parameter 2-15 Brake Check*.

ALARM 29, Heat Sink temp

The maximum temperature of the heatsink has been exceeded. The temperature fault does not reset until the temperature drops below a defined heatsink temperature.

The trip and reset points vary based on the frequency converter power size.

Troubleshooting

Check for the following conditions:

- Ambient temperature too high.
- Motor cable too long.
- Incorrect airflow clearance above and below the frequency converter.
- Blocked airflow around the frequency converter.
- Damaged heatsink fan.
- Dirty heatsink.

This alarm is based on the temperature measured by the heatsink sensor mounted inside the IGBT modules.

Troubleshooting

- Check the fan resistance.
- Check the soft charge fuses.
- Check the IGBT thermal sensor.

ALARM 30, Motor phase U missing

Motor phase U between the frequency converter and the motor is missing.

Troubleshooting

- Remove power from the frequency converter and check motor phase U.

ALARM 31, Motor phase V missing

Motor phase V between the frequency converter and the motor is missing.

Troubleshooting

- Remove power from the frequency converter and check motor phase V.

ALARM 32, Motor phase W missing

Motor phase W between the frequency converter and the motor is missing.

Troubleshooting

- Remove power from the frequency converter and check motor phase W.

ALARM 33, Inrush fault

Too many power-ups have occurred within a short time period. Let the unit cool to operating temperature.

WARNING/ALARM 34, Fieldbus communication fault

The fieldbus on the communication option card is not working.

WARNING/ALARM 36, Mains failure

This warning/alarm is only active if the supply voltage to the frequency converter is lost and *parameter 14-10 Mains Failure* is NOT set to [0] No Function.

Troubleshooting

- Check the fuses to the frequency converter and mains power supply to the unit.

ALARM 38, Internal fault

When an internal fault occurs, a code number defined in *Table 7.4* is displayed.

Troubleshooting

- Cycle power.
- Check that the option is properly installed.
- Check for loose or missing wiring.

Contact the KSB supplier or KSB service if necessary. Note the code number for further troubleshooting directions.

No.	Text
0	Serial port cannot be initialised. Contact the KSB supplier or KSB Service.
256–258	Power EEPROM data is defective or too old.
512	Control board EEPROM data is defective or too old.
513	Communication timeout reading EEPROM data.
514	Communication timeout reading EEPROM data.
515	Application-oriented control cannot recognise the EEPROM data.
516	Cannot write to the EEPROM because a write command is in progress.
517	Write command is under timeout.
518	Failure in the EEPROM.
519	Missing or invalid barcode data in EEPROM.
783	Parameter value outside of min/max limits.
1024–1279	Sending a CAN telegram failed.
1281	Digital signal processor flash timeout.
1282	Power micro software version mismatch.
1283	Power EEPROM data version mismatch.
1284	Cannot read digital signal processor software version.
1299	Option SW in slot A is too old.
1300	Option SW in slot B is too old.
1301	Option SW in slot C0 is too old.
1302	Option SW in slot C1 is too old.
1315	Option SW in slot A is not supported (not allowed).
1316	Option SW in slot B is not supported (not allowed).
1317	Option SW in slot C0 is not supported (not allowed).
1318	Option SW in slot C1 is not supported (not allowed).
1379	Option A did not respond when calculating platform version.
1380	Option B did not respond when calculating platform version.
1381	Option C0 did not respond when calculating platform version.
1382	Option C1 did not respond when calculating platform version.
1536	An exception in the application-oriented control is registered. Debug information written in LCP.

No.	Text
1792	DSP watchdog is active. Debugging of power part data, motor-oriented control data not transferred correctly.
2049	Power data restarted.
2064–2072	H081x: option in slot x has restarted.
2080–2088	H082x: option in slot x has issued a power-up wait.
2096–2104	H983x: option in slot x has issued a legal power-up wait.
2304	Could not read any data from power EEPROM.
2305	Missing SW version from power unit.
2314	Missing power unit data from power unit.
2315	Missing SW version from power unit.
2316	Missing lo_statepage from power unit.
2324	Power card configuration is determined to be incorrect at power-up.
2325	A power card has stopped communicating while main power is applied.
2326	Power card configuration is determined to be incorrect after the delay for power cards to register.
2327	Too many power card locations have been registered as present.
2330	Power size information between the power cards does not match.
2561	No communication from DSP to ATACD.
2562	No communication from ATACD to DSP (state running).
2816	Stack overflow control board module.
2817	Scheduler slow tasks.
2818	Fast tasks.
2819	Parameter thread.
2820	LCP stack overflow.
2821	Serial port overflow.
2822	USB port overflow.
2836	cfListMempool too small.
3072–5122	Parameter value is outside its limits.
5123	Option in slot A: Hardware incompatible with control board hardware.
5124	Option in slot B: Hardware incompatible with Control board hardware.
5125	Option in slot C0: Hardware incompatible with control board hardware.
5126	Option in slot C1: Hardware incompatible with control board hardware.
5376–6231	Out of memory.

Table 7.4 Code Numbers for Internal Faults

ALARM 39, Heat sink sensor

No feedback from the heat sink temperature sensor.

The signal from the IGBT thermal sensor is not available on the power card. The problem could be on the power card, on the gate drive card, or the ribbon cable between the power card and gate drive card.

WARNING 40, Overload of digital output terminal 27

Check the load connected to terminal 27 or remove the short-circuit connection. Check *parameter 5-00 Digital I/O Mode* and *parameter 5-01 Terminal 27 Mode*.

WARNING 41, Overload of digital output terminal 29

Check the load connected to terminal 29 or remove the short-circuit connection. Check *parameter 5-00 Digital I/O Mode* and *parameter 5-02 Terminal 29 Mode*.

WARNING 42, Overload of digital output on X30/6 or overload of digital output on X30/7

For X30/6, check the load connected to X30/6 or remove the short-circuit connection. Check *parameter 5-32 Term X30/6 Digi Out (MCB 101)*.

For X30/7, check the load connected to X30/7 or remove the short-circuit connection. Check *parameter 5-33 Term X30/7 Digi Out (MCB 101)*.

ALARM 46, Power card supply

The supply on the power card is out of range.

There are 3 power supplies generated by the switch mode power supply (SMPS) on the power card: 24 V, 5 V, ± 18 V. When powered with 24 V DC with the MCB 107 option, only the 24 V and 5 V supplies are monitored. When powered with 3-phase mains voltage, all 3 supplies are monitored.

WARNING 47, 24 V supply low

The 24 V DC supply is measured on the control card. The external 24 V DC back-up power supply may be overloaded, otherwise contact the KSB supplier.

WARNING 48, 1.8 V supply low

The 1.8 V DC supply used on the control card is outside of the allowable limits. The power supply is measured on the control card. Check for a defective control card. If an option card is present, check for an overvoltage condition.

WARNING 49, Speed limit

When the speed is not within the specified range in *parameter 4-11 Motor Speed Low Limit [RPM]* and *parameter 4-13 Motor Speed High Limit [RPM]*, the frequency converter displays a warning. When the speed is below the specified limit in *parameter 1-86 Trip Speed Low [RPM]* (except when starting or stopping) the frequency converter trips.

ALARM 50, AMA calibration failed

Contact the KSB supplier or KSB Service.

ALARM 51, AMA check U_{nom} and I_{nom}

The settings for motor voltage, motor current, and motor power are wrong. Check the settings in parameters 1-20 to 1-25.

ALARM 52, AMA low I_{nom}

The motor current is too low. Check the settings.

ALARM 53, AMA motor too big

The motor is too big for the AMA to operate.

ALARM 54, AMA motor too small

The motor is too small for the AMA to operate.

ALARM 55, AMA parameter out of range

The parameter values of the motor are outside of the acceptable range. AMA does not run.

ALARM 56, AMA interrupted by user

The user has interrupted the AMA.

ALARM 57, AMA internal fault

Try to restart AMA a number of times, until the AMA is carried out. Note that repeated runs may heat the motor to a level where the resistance R_s and R_r are increased. In most cases, however, this is not critical.

ALARM 58, AMA Internal fault

Contact the KSB supplier.

WARNING 59, Current limit

The current is higher than the value in *parameter 4-18 Current Limit*. Ensure that motor data in parameters 1-20 to 1-25 are set correctly. Possibly increase the current limit. Be sure that the system can operate safely at a higher limit.

WARNING 60, External interlock

External interlock has been activated. To resume normal operation:

1. Apply 24 V DC to the terminal programmed for external interlock.
2. Reset the frequency converter via
 - 2a serial communication.
 - 2b digital I/O.
 - 2c by pressing [Reset].

WARNING 62, Output frequency at maximum limit

The output frequency is higher than the value set in *parameter 4-19 Max Output Frequency*.

WARNING 64, Voltage Limit

The load and speed combination demands a motor voltage higher than the actual DC link voltage.

WARNING/ALARM 65, Control card over temperature

The control card has reached its trip temperature of 75 °C.

WARNING 66, Heat sink temperature low

The frequency converter is too cold to operate. This warning is based on the temperature sensor in the IGBT module.

Increase the ambient temperature of the unit. Also, a trickle amount of current can be supplied to the frequency converter whenever the motor is stopped by setting *parameter 2-00 DC Hold/Preheat Current* at 5% and *parameter 1-80 Function at Stop*.

Troubleshooting

- Check the temperature sensor.
- Check the sensor wire between the IGBT and the gate drive card.

ALARM 67, Option module configuration has changed

One or more options have either been added or removed since the last power-down. Check that the configuration change is intentional and reset the unit.

ALARM 68, Safe Stop activated

STO has been activated.

Troubleshooting

- To resume normal operation, apply 24 V DC to terminal 37, then send a reset signal (via bus, digital I/O, or by pressing [Reset]).

ALARM 69, Power card temperature

The temperature sensor on the power card is either too hot or too cold.

Troubleshooting

- Check the operation of the door fans.
- Check that the filters for the door fans are not blocked.
- Check that the gland plate is properly installed on IP21/IP54 (NEMA 1/12) frequency converters.

ALARM 70, Illegal FC configuration

The control card and power card are incompatible.

Troubleshooting

- Contact the supplier with the type code of the unit from the nameplate and the part numbers of the cards to check compatibility.

ALARM 71, PTC 1 safe stop

Safe Stop has been activated from the VLT® PTC Thermistor Card MCB 112 (motor too warm). Normal operation can be resumed when the MCB 112 applies 24 V DC to T37 again (when the motor temperature reaches an acceptable level) and when the digital input from the MCB 112 is deactivated. When that happens, a reset signal must be sent (via bus, digital I/O, or by pressing [Reset]).

NOTICE

If automatic restart is enabled, the motor may start when the fault is cleared.

ALARM 72, Dangerous failure

Safe Torque Off (STO) with trip lock. Unexpected signal levels on safe torque off (STO) and digital input from the VLT® PTC Thermistor Card MCB 112.

WARNING 73, Safe Stop auto restart

Safe Torque Off (STO). With automatic restart enabled, the motor can start when the fault is cleared.

WARNING 76, Power unit setup

The required number of power units does not match the detected number of active power units. When replacing an enclosure size F module, this warning occurs if the power-specific data in the module power card does not match the rest of the frequency converter. The warning is also triggered if the power card connection is lost.

Troubleshooting

- Confirm that the spare part and its power card are the correct part number.
- Ensure that the 44-pin cables between the MDCIC and power cards are mounted properly.

WARNING 77, Reduced power mode

This warning indicates that the frequency converter is operating in reduced power mode (that is, less than the allowed number of inverter sections). This warning is generated on power cycle when the frequency converter is set to run with fewer inverters and remains on.

ALARM 79, Illegal power section configuration

The scaling card is the incorrect part number or not installed. Also, the MK102 connector on the power card could not be installed.

ALARM 80, Drive initialised to default value

Parameter settings are initialised to default settings after a manual reset.

Troubleshooting

- Reset the unit to clear the alarm.

ALARM 81, CSIV corrupt

CSIV (Customer Specific Initialisation Values) file has syntax errors.

ALARM 82, CSIV parameter error

CSIV (Customer Specific Initialisation Values) failed to initialise a parameter.

ALARM 85, Dang fail PB

PROFIBUS/PROFIsafe error.

ALARM 92, No flow

A no-flow condition has been detected in the system.

Parameter 22-23 No-Flow Function is set for alarm.

Troubleshooting

- Troubleshoot the system and reset the frequency converter after the fault has been cleared.

ALARM 93, Dry pump

A no-flow condition in the system with the frequency converter operating at high speed may indicate a dry pump. *Parameter 22-26 Dry Pump Function* is set for alarm.

Troubleshooting

- Troubleshoot the system and reset the frequency converter after the fault has been cleared.

ALARM 94, End of curve

The feedback is lower than the setpoint. This may indicate leakage in the system. *Parameter 22-50 End of Curve Function* is set for alarm.

Troubleshooting

- Troubleshoot the system and reset the frequency converter after the fault has been cleared.

ALARM 95, Broken belt

Torque is below the torque level set for no load, indicating a broken belt. *Parameter 22-60 Broken Belt Function* is set for alarm.

Troubleshooting

- Troubleshoot the system and reset the frequency converter after the fault has been cleared.

ALARM 100, Derag limit fault

The *Deragging* feature failed during execution. Check the pump impeller for blockage.

WARNING/ALARM 104, Mixing fan fault

The fan monitor checks that the fan is spinning at frequency converter power-up or whenever the mixing fan is turned on. If the fan is not operating, the fault is issued. The mixing-fan fault can be configured as a warning or an alarm trip by *parameter 14-53 Fan Monitor*.

Troubleshooting

- Cycle power to the frequency converter to determine if the warning/alarm returns.

WARNING 250, New spare part

A component in the frequency converter has been replaced. To resume normal operation, reset the frequency converter.

WARNING 251, New typecode

The power card or other components have been replaced and the type code changed.

Troubleshooting

- Reset to remove the warning and resume normal operation.

7.5 Troubleshooting

Symptom	Possible cause	Test	Solution
Display dark/No function	Missing input power.	See <i>Table 4.3</i> .	Check the input power source.
	Missing or open fuses or circuit breaker tripped.	See open fuses and tripped circuit breaker in this table for possible causes.	Follow the recommendations provided.
	No power to the LCP.	Check the LCP cable for proper connection or damage.	Replace the faulty LCP or connection cable.
	Shortcut on control voltage (terminal 12 or 50) or at control terminals.	Check the 24 V control voltage supply for terminals 12/13 to 20-39 or 10 V supply for terminals 50-55.	Wire the terminals properly.
	Incompatible LCP.		Use only LCP 101 (P/N 130B1124) or LCP 102 (P/N 130B1107).
	Wrong contrast setting.		Press [Status] + [▲]/[▼] to adjust the contrast.
	Display (LCP) is defective.	Test using a different LCP.	Replace the faulty LCP or connection cable.
	Internal voltage supply fault or SMPS is defective.		Contact supplier.
Intermittent display	Overloaded power supply (SMPS) due to improper control wiring or a fault within the frequency converter.	To rule out a problem in the control wiring, disconnect all control wiring by removing the terminal blocks.	If the display stays lit, the problem is in the control wiring. Check the wiring for short circuits or incorrect connections. If the display continues to cut out, follow the procedure for display dark.
Motor not running	Service switch is open or missing motor connection.	Check if the motor is connected and the connection is not interrupted (by a service switch or other device).	Connect the motor and check the service switch.
	No mains power with 24 V DC option card.	If the display is functioning but no output, check that mains power is applied to the frequency converter.	Apply mains power to run the unit.
	LCP stop.	Check if [Off] has been pressed.	Press [Auto On] or [Hand On] (depending on operation mode) to run the motor.
	Missing start signal (Standby).	Check <i>parameter 5-10 Terminal 18 Digital Input</i> for correct setting for terminal 18 (use default setting).	Apply a valid start signal to start the motor.
	Motor coast signal active (Coasting).	Check <i>parameter 5-12 Terminal 27 Digital Input</i> for correct setting for terminal 27 (use default setting).	Apply 24 V on terminal 27 or program this terminal to <i>No operation</i> .
	Wrong reference signal source.	Check reference signal: Local, remote or bus reference? Preset reference active? Terminal connection correct? Scaling of terminals correct? Reference signal available?	Programme the correct settings. Check <i>parameter 3-13 Reference Site</i> . Set preset reference active in parameter group 3-1* <i>References</i> . Check for correct wiring. Check scaling of terminals. Check reference signal.
Motor running in wrong direction	Motor rotation limit.	Check that <i>parameter 4-10 Motor Speed Direction</i> is programmed correctly.	Programme the correct settings.
	Active reversing signal.	Check if a reversing command is programmed for the terminal in parameter group 5-1* <i>Digital inputs</i> .	Deactivate reversing signal.
	Wrong motor phase connection.		See <i>chapter 5.5 Checking Motor Rotation</i> .

Symptom	Possible cause	Test	Solution
Motor is not reaching maximum speed	Frequency limits are set incorrectly.	Check the output limits in <i>parameter 4-13 Motor Speed High Limit [RPM]</i> , <i>parameter 4-14 Motor Speed High Limit [Hz]</i> and <i>parameter 4-19 Max Output Frequency</i> .	Programme the correct limits.
	Reference input signal is not scaled correctly.	Check the reference input signal scaling in parameter group <i>6-0* Analog I/O Mode</i> and parameter group <i>3-1* References</i> . Check the reference limits in parameter group <i>3-0* Reference Limit</i> .	Programme the correct settings.
Motor speed unstable	Possible incorrect parameter settings.	Check the settings of all motor parameters, including all motor compensation settings. For closed-loop operation, check the PID settings.	Check the settings in parameter group <i>1-6* Load Depen. Setting</i> . For closed-loop operation, check the settings in parameter group <i>20-0* Feedback</i> .
Motor runs rough	Possible over-magnetisation.	Check for incorrect motor settings in all motor parameters.	Check the motor settings in parameter groups <i>1-2* Motor Data</i> , <i>1-3* Adv Motor Data</i> , and <i>1-5* Load Indep. Setting</i> .
Motor will not brake	Possible incorrect settings in the brake parameters. Possible too short ramp-down times.	Check the brake parameters. Check the ramp-time settings.	Check parameter group <i>2-0* DC Brake</i> and <i>3-0* Reference Limits</i> .
Open power fuses or circuit breaker trip	Phase-to-phase short circuit.	The motor or panel has a short phase-to-phase. Check the motor and panel phase for short circuits.	Eliminate any short circuits detected.
	Motor overload.	Motor is overloaded for the application.	Perform a startup test and verify the motor current is within the specifications. If the motor current exceeds the nameplate full load current, the motor may run only with reduced load. Review the specifications for the application.
	Loose connections.	Perform a pre-startup check for loose connections.	Tighten any loose connections.
Mains current imbalance >3%	Problem with the mains power (See <i>Alarm 4 Mains phase loss</i> description).	Rotate input power leads into the frequency converter 1 position: A to B, B to C, C to A.	If imbalanced leg follows the wire, it is a power problem. Check the mains power supply.
	Problem with the frequency converter.	Rotate input power leads into the frequency converter 1 position: A to B, B to C, C to A.	If imbalance leg stays on the same input terminal, it is a problem with the unit. Contact the supplier.
Motor current imbalance >3%	Problem with the motor or motor wiring.	Rotate output motor leads 1 position: U to V, V to W, W to U.	If imbalanced leg follows the wire, the problem is in the motor or motor wiring. Check the motor and motor wiring.
	Problem with the frequency converter.	Rotate output motor leads 1 position: U to V, V to W, W to U.	If imbalance leg stays on same output terminal, it is a problem with the frequency converter. Contact the Danfoss supplier.
Frequency converter acceleration problems	Motor data was entered incorrectly.	If warnings or alarms occur, see <i>chapter 7.4 List of Warnings and Alarms</i> . Check that motor data is entered correctly.	Increase the ramp-up time in <i>parameter 3-41 Ramp 1 Ramp Up Time</i> . Increase the current limit in <i>parameter 4-18 Current Limit</i> . Increase the torque limit in <i>parameter 4-16 Torque Limit Motor Mode</i> .
Frequency converter deceleration problems	Motor data was entered incorrectly.	If warnings or alarms occur, see <i>chapter 7.4 List of Warnings and Alarms</i> . Check that motor data is entered correctly.	Increase the ramp-down time in <i>parameter 3-42 Ramp 1 Ramp Down Time</i> . Enable overvoltage control in <i>parameter 2-17 Over-voltage Control</i> .

Symptom	Possible cause	Test	Solution
Acoustic noise or vibration	Resonances.	Bypass critical frequencies by using parameters in parameter group 4-6* <i>Speed Bypass</i> .	Check if noise and/or vibration have been reduced to an acceptable limit.
		Turn off over-modulation in <i>parameter 14-03 Overmodulation</i> .	
		Change the switching pattern and frequency in parameter group 14-0* <i>Inverter Switching</i> .	
		Increase Resonance Dampening in <i>parameter 1-64 Resonance Dampening</i> .	

Table 7.5 Troubleshooting

8 Specifications

8.1 Electrical Data

8.1.1 Mains Supply 1x200–240 V AC

Type designation	P1K1	P1K5	P2K2	P3K0	P3K7	P5K5	P7K5	P15K	P22K
Typical shaft output [kW]	1.1	1.5	2.2	3.0	3.7	5.5	7.5	15	22
Typical shaft output at 240 V [hp]	1.5	2.0	2.9	4.0	4.9	7.5	10	20	30
Protection rating IP20/Chassis	A3	–	–	–	–	–	–	–	–
Protection rating IP21/Type 1	–	B1	B1	B1	B1	B1	B2	C1	C2
Protection rating IP55/Type 12	A5	B1	B1	B1	B1	B1	B2	C1	C2
Protection rating IP66/NEMA 4X	A5	B1	B1	B1	B1	B1	B2	C1	C2
Output current									
Continuous (3x200–240 V) [A]	6.6	7.5	10.6	12.5	16.7	24.2	30.8	59.4	88
Intermittent (3x200–240 V) [A]	7.3	8.3	11.7	13.8	18.4	26.6	33.4	65.3	96.8
Continuous kVA at 208 V [kVA]	2.4	2.7	3.8	4.5	6.0	8.7	11.1	21.4	31.7
Maximum input current									
Continuous (1x200–240 V) [A]	12.5	15	20.5	24	32	46	59	111	172
Intermittent (1x200–240 V) [A]	13.8	16.5	22.6	26.4	35.2	50.6	64.9	122.1	189.2
Maximum pre-fuses [A]	20	30	40	40	60	80	100	150	200
Additional specifications									
Maximum cable cross-section (mains, motor, brake) [mm ²] ([AWG])	0.2–4 (4–10)					10 (7)	35 (2)	50 (1/0)	95 (4/0)
Maximum cable cross-section for mains with disconnect switch [mm ²] ([AWG])	5.26 (10)	16 (6)	16 (6)	16 (6)	16 (6)	16 (6)	25 (3)	50 (1/0)	2 x 50 (2 x 1/0) ^{9) 10)}
Maximum cable cross-section for mains without disconnect switch [mm ²] ([AWG])	5.26 (10)	16 (6)	16 (6)	16 (6)	16 (6)	16 (6)	25 (3)	50 (1/0)	95 (4/0)
Cable insulation temperature rating [°C]	75	75	75	75	75	75	75	75	75
Estimated power loss ³⁾ at rated maximum load [W] ⁴⁾	44	30	44	60	74	110	150	300	440
Efficiency ⁵⁾	0.98	0.98	0.98	0.98	0.98	0.98	0.98	0.98	0.98

Table 8.1 Mains Supply 1x200–240 V AC, Normal Overload 110% for 1 Minute, P1K1–P22K

Specifications

8.1.2 Mains Supply 3x200–240 V AC

Type designation	PK25		PK37		PK55		PK75	
	HO	NO	HO	NO	HO	NO	HO	NO
High/normal overload ¹⁾								
Typical shaft output [kW]	0.25		0.37		0.55		0.75	
Typical shaft output at 208 V [hp]	0.34		0.5		0.75		1	
Protection rating IP20/Chassis ⁶⁾	A2		A2		A2		A2	
Protection rating IP21/Type 1								
Protection rating IP55/Type 12	A4/A5		A4/A5		A4/A5		A4/A5	
Protection rating IP66/NEMA 4X								
Output current								
Continuous (3x200–240 V) [A]	1.8		2.4		3.5		4.6	
Intermittent (3x200–240 V) [A]	2.7	2.0	3.6	2.6	5.3	3.9	6.9	5.1
Continuous kVA at 208 V [kVA]	0.65		0.86		1.26		1.66	
Maximum input current								
Continuous (3x200–240 V) [A]	1.6		2.2		3.2		4.1	
Intermittent (3x200–240 V) [A]	2.4	1.8	3.3	2.4	4.8	3.5	6.2	4.5
Maximum pre-fuses [A]	10		10		10		10	
Additional specifications								
Maximum cable cross-section ²⁾ for mains, motor, brake, and load sharing [mm ²] (AWG)	4, 4, 4 (12, 12, 12) (minimum 0.2 (24))							
Maximum cable cross-section ²⁾ for mains disconnect [mm ²] (AWG)	6, 4, 4 (10, 12, 12)							
Estimated power loss ³⁾ at rated maximum load [W] ⁴⁾	21		29		42		54	
Efficiency ⁵⁾	0.94		0.94		0.95		0.95	

Table 8.2 Mains Supply 3x200–240 V AC, PK25–PK75

Type designation	P1K1		P1K5		P2K2		P3K0		P3K7	
	HO	NO	HO	NO	HO	NO	HO	NO	HO	NO
High/normal overload ¹⁾										
Typical shaft output [kW]	1.1		1.5		2.2		3.0		3.7	
Typical shaft output at 208 V [hp]	1.5		2		3		4		5	
Protection rating IP20/Chassis ⁶⁾	A2		A2		A2		A3		A3	
Protection rating IP21/Type 1										
Protection rating IP55/Type 12	A4/A5		A4/A5		A4/A5		A5		A5	
Protection rating IP66/NEMA 4X										
Output current										
Continuous (3x200–240 V) [A]	6.6		7.5		10.6		12.5		16.7	
Intermittent (3x200–240 V) [A]	9.9	7.3	11.3	8.3	15.9	11.7	18.8	13.8	25	18.4
Continuous kVA at 208 V [kVA]	2.38		2.70		3.82		4.50		6.00	
Maximum input current										
Continuous (3x200–240 V) [A]	5.9		6.8		9.5		11.3		15.0	
Intermittent (3x200–240 V) [A]	8.9	6.5	10.2	7.5	14.3	10.5	17.0	12.4	22.5	16.5
Maximum pre-fuses [A]	20		20		20		32		32	
Additional specifications										
Maximum cable cross-section ²⁾ for mains, motor, brake, and load sharing [mm ²] (AWG)	4, 4, 4 (12, 12, 12) (minimum 0.2 (24))									
Maximum cable cross-section ²⁾ for mains disconnect [mm ²] (AWG)	6, 4, 4 (10, 12, 12)									
Estimated power loss ³⁾ at rated maximum load [W] ⁴⁾	63		82		116		155		185	
Efficiency ⁵⁾	0.96		0.96		0.96		0.96		0.96	

Table 8.3 Mains Supply 3x200–240 V AC, P1K1–P3K7

Specifications

Type designation	P5K5		P7K5		P11K		P15K	
High/normal overload ¹⁾	HO	NO	HO	NO	HO	NO	HO	NO
Typical shaft output [kW]	3.7	5.5	5.5	7.5	7.5	11	11	15
Typical shaft output at 208 V [hp]	5.0	7.5	7.5	10	10	15	15	20
IP20/Chassis ⁷⁾	B3		B3		B3		B4	
Protection rating IP21/Type 1	B1		B1		B1		B2	
Protection rating IP55/Type 12								
Protection rating IP66/NEMA 4X								
Output current								
Continuous (3x200–240 V) [A]	16.7	24.2	24.2	30.8	30.8	46.2	46.2	59.4
Intermittent (3x200–240 V) [A]	26.7	26.6	38.7	33.9	49.3	50.8	73.9	65.3
Continuous kVA at 208 V [kVA]	6.0	8.7	8.7	11.1	11.1	16.6	16.6	21.4
Maximum input current								
Continuous (3x200–240 V) [A]	15.0	22.0	22.0	28.0	28.0	42.0	42.0	54.0
Intermittent (3x200–240 V) [A]	24.0	24.2	35.2	30.8	44.8	46.2	67.2	59.4
Maximum pre-fuses [A]	63		63		63		80	
Additional specifications								
IP20 maximum cable cross-section ²⁾ for mains, brake, motor, and load sharing [mm ²] ([AWG])	10, 10, – (8, 8, –)		10, 10, – (8, 8, –)		10, 10, – (8, 8, –)		35, –, – (2, –, –)	
Protection rating IP21 maximum cable cross-section ²⁾ for mains, brake, and load sharing [mm ²] ([AWG])	16, 10, 16 (6, 8, 6)		16, 10, 16 (6, 8, 6)		16, 10, 16 (6, 8, 6)		35, –, – (2, –, –)	
Protection rating IP21 maximum cable cross-section ²⁾ for motor [mm ²] ([AWG])	10, 10, – (8, 8, –)		10, 10, – (8, 8, –)		10, 10, – (8, 8, –)		35, 25, 25 (2, 4, 4)	
Maximum cable cross-section ²⁾ for mains disconnect [mm ²] ([AWG])	16, 10, 10 (6, 8, 8)						35 (2)	
Estimated power loss ³⁾ at rated maximum load [W] ⁴⁾	239	310	239	310	371	514	463	602
Efficiency ⁵⁾	0.96		0.96		0.96		0.96	

Table 8.4 Mains Supply 3x200–240 V AC, P5K5–P15K

Specifications

Type designation	P18K		P22K		P30K		P37K		P45K	
High/normal overload ¹⁾	HO	NO	HO	NO	HO	NO	HO	NO	HO	NO
Typical shaft output [kW]	15	18.5	18.5	22	22	30	30	37	37	45
Typical shaft output at 208 V [hp]	20	25	25	30	30	40	40	50	50	60
Protection rating IP20/Chassis ⁷⁾	B4		C3		C3		C4		C4	
Protection rating IP21/Type 1										
Protection rating IP55/Type 12	C1		C1		C1		C2		C2	
Protection rating IP66/NEMA 4X										
Output current										
Continuous (3x200–240 V) [A]	59.4	74.8	74.8	88.0	88.0	115	115	143	143	170
Intermittent (3x200–240 V) [A]	89.1	82.3	112	96.8	132	127	173	157	215	187
Continuous kVA at 208 V [kVA]	21.4	26.9	26.9	31.7	31.7	41.4	41.4	51.5	51.5	61.2
Maximum input current										
Continuous (3x200–240 V) [A]	54.0	68.0	68.0	80.0	80.0	104	104	130	130	154.0
Intermittent (3x200–240 V) [A]	81.0	74.8	102	88.0	120	114	156	143	195	169.0
Maximum pre-fuses [A]	125		125		160		200		250	
Additional specifications										
Protection rating IP20 maximum cable cross-section for mains, brake, motor, and load sharing [mm ²] ([AWG])	35 (2)		50 (1)		50 (1)		150 (300 MCM)		150 (300 MCM)	
Protection ratings IP21, IP55, IP66 maximum cable cross-section for mains and motor [mm ²] ([AWG])	50 (1)		50 (1)		50 (1)		150 (300 MCM)		150 (300 MCM)	
Protection ratings IP21, IP55, IP66 maximum cable cross-section for brake, and load sharing [mm ²] ([AWG])	50 (1)		50 (1)		50 (1)		95 (3/0)		95 (3/0)	
Maximum cable cross-section ²⁾ for disconnect [mm ²] ([AWG])			50, 35, 35 (1, 2, 2)				95, 70, 70 (3/0, 2/0, 2/0)		185, 150, 120 (350 MCM, 300 MCM, 4/0)	
Estimated power loss ³⁾ at rated maximum load [W] ⁴⁾	624	737	740	845	874	1140	1143	1353	1400	1636
Efficiency ⁵⁾	0.96		0.97		0.97		0.97		0.97	

Table 8.5 Mains Supply 3x200–240 V AC, P18K–P45K

8.1.3 Mains Supply 1x380–480 V AC

Type designation	P7K5	P11K	P18K	P37K
Typical shaft output [kW]	7.5	11	18.5	37
Typical shaft output at 240 V [hp]	10	15	25	50
Protection rating IP21/Type 1	B1	B2	C1	C2
Protection rating IP55/Type 12	B1	B2	C1	C2
Protection rating IP66/NEMA 4X	B1	B2	C1	C2
Output current				
Continuous (3x380–440 V) [A]	16	24	37.5	73
Intermittent (3x380–440 V) [A]	17.6	26.4	41.2	80.3
Continuous (3x441–480 V) [A]	14.5	21	34	65
Intermittent (3x441–480 V) [A]	15.4	23.1	37.4	71.5
Continuous kVA at 400 V [kVA]	11.0	16.6	26	50.6
Continuous kVA at 460 V [kVA]	11.6	16.7	27.1	51.8
Maximum input current				
Continuous (1x380–440 V) [A]	33	48	78	151
Intermittent (1x380–440 V) [A]	36	53	85.5	166

Specifications

Type designation	P7K5	P11K	P18K	P37K
Continuous (1x441–480 V) [A]	30	41	72	135
Intermittent (1x441–480 V) [A]	33	46	79.2	148
Maximum pre-fuses [A]	63	80	160	250
Additional specifications				
Maximum cable cross-section for mains, motor, and brake [mm ²] ([AWG])	10 (7)	35 (2)	50 (1/0)	120 (4/0)
Estimated power loss ³⁾ at rated maximum load [W] ⁴⁾	300	440	740	1480
Efficiency ⁵⁾	0.96	0.96	0.96	0.96

Table 8.6 Mains Supply 1x380–480 V AC, Normal Overload 110% for 1 Minute, P7K5–P37K

8.1.4 Mains Supply 3x380–480 V AC

Type designation	PK37		PK55		PK75		P1K1		P1K5	
	HO	NO	HO	NO	HO	NO	HO	NO	HO	NO
High/normal overload ¹⁾										
Typical shaft output [kW]	0.37		0.55		0.75		1.1		1.5	
Typical shaft output at 460 V [hp]	0.5		0.75		1.0		1.5		2.0	
Protection rating IP20/Chassis ⁶⁾	A2		A2		A2		A2		A2	
Protection rating IP55/Type 12	A4/A5		A4/A5		A4/A5		A4/A5		A4/A5	
Protection rating IP66/NEMA 4X	A4/A5		A4/A5		A4/A5		A4/A5		A4/A5	
Output current										
Continuous (3x380–440 V) [A]	1.3		1.8		2.4		3.0		4.1	
Intermittent (3x380–440 V) [A]	2.0	1.4	2.7	2.0	3.6	2.6	4.5	3.3	6.2	4.5
Continuous (3x441–480 V) [A]	1.2		1.6		2.1		2.7		3.4	
Intermittent (3x441–480 V) [A]	1.8	1.3	2.4	1.8	3.2	2.3	4.1	3.0	5.1	3.7
Continuous kVA at 400 V [kVA]	0.9		1.3		1.7		2.1		2.8	
Continuous kVA at 460 V [kVA]	0.9		1.3		1.7		2.4		2.7	
Maximum input current										
Continuous (3x380–440 V) [A]	1.2		1.6		2.2		2.7		3.7	
Intermittent (3x380–440 V) [A]	1.8	1.3	2.4	1.8	3.3	2.4	4.1	3.0	5.6	4.1
Continuous (3x441–480 V) [A]	1.0		1.4		1.9		2.7		3.1	
Intermittent (3x441–480 V) [A]	1.5	1.1	2.1	1.5	2.9	2.1	4.1	3.0	4.7	3.4
Maximum pre-fuses [A]	10		10		10		10		10	
Additional specifications										
Protection ratings IP20, IP21 maximum cable cross-section ²⁾ for mains, motor, brake, and load sharing [mm ²] ([AWG])	4, 4, 4 (12, 12, 12) (minimum 0.2 (24))									
Protection ratings IP55, IP66 maximum cable cross-section ²⁾ for mains, motor, brake, and load sharing [mm ²] ([AWG])	4, 4, 4 (12, 12, 12)									
Maximum cable cross-section ²⁾ for disconnect [mm ²] ([AWG])	6, 4, 4 (10, 12, 12)									
Estimated power loss ³⁾ at rated maximum load [W] ⁴⁾	35		42		46		58		62	
Efficiency ⁵⁾	0.93		0.95		0.96		0.96		0.97	

Table 8.7 Mains Supply 3x380–480 V AC, PK37–P1K5

Specifications

Type designation	P2K2		P3K0		P4K0		P5K5		P7K5	
	HO	NO	HO	NO	HO	NO	HO	NO	HO	NO
High/normal overload ¹⁾										
Typical shaft output [kW]	2.2		3.0		4.0		5.5		7.5	
Typical shaft output at 460 V [hp]	2.9		4.0		5.3		7.5		10	
Protection rating IP20/Chassis ⁶⁾	A2		A2		A2		A3		A3	
Protection rating IP55/Type 12	A4/A5		A4/A5		A4/A5		A5		A5	
Protection rating IP66/NEMA 4X	A4/A5		A4/A5		A4/A5		A5		A5	
Output current										
Continuous (3x380–440 V) [A]	5.6		7.2		10		13		16	
Intermittent (3x380–440 V) [A]	8.4	6.2	10.8	7.9	15.0	11.0	19.5	14.3	24.0	17.6
Continuous (3x441–480 V) [A]	4.8		6.3		8.2		11		14.5	
Intermittent (3x441–480 V) [A]	7.2	5.3	9.5	6.9	12.3	9.0	16.5	12.1	21.8	16.0
Continuous kVA at 400 V [kVA]	3.9		5.0		6.9		9.0		11.0	
Continuous kVA at 460 V [kVA]	3.8		5.0		6.5		8.8		11.6	
Maximum input current										
Continuous (3x380–440 V) [A]	5.0		6.5		9.0		11.7		14.4	
Intermittent (3x380–440 V) [A]	7.5	5.5	9.8	7.2	13.5	9.9	17.6	12.9	21.6	15.8
Continuous (3x441–480 V) [A]	4.3		5.7		7.4		9.9		13.0	
Intermittent (3x441–480 V) [A]	6.5	4.7	8.6	6.3	11.1	8.1	14.9	10.9	19.5	14.3
Maximum pre-fuses [A]	20		20		20		30		30	
Additional specifications										
Protection ratings IP20, IP21 maximum cable cross-section ²⁾ for mains, motor, brake, and load sharing [mm ²] ([AWG])	4, 4, 4 (12, 12, 12) (minimum 0.2 (24))									
Protection ratings IP55, IP66 maximum cable cross-section ²⁾ for mains, motor, brake, and load sharing [mm ²] ([AWG])	4, 4, 4 (12, 12, 12)									
Maximum cable cross-section ²⁾ for disconnect [mm ²] ([AWG])	6, 4, 4 (10, 12, 12)									
Estimated power loss ³⁾ at rated maximum load [W] ⁴⁾	88		116		124		187		225	
Efficiency ⁵⁾	0.97		0.97		0.97		0.97		0.97	

Table 8.8 Mains Supply 3x380–480 V AC, P2K2–P7K5

Specifications

Type designation	P11K		P15K		P18K		P22K		P30K	
High/normal overload ¹⁾	HO	NO	HO	NO	HO	NO	HO	NO	HO	NO
Typical shaft output [kW]	7.5	11	11	15	15	18.5	22.0	22.0	22.0	30
Typical shaft output at 460 V [hp]	10	15	15	20	20	25	30	30	30	40
Protection rating IP20/Chassis ⁷⁾	B3		B3		B3		B4			B4
Protection rating IP21/Type 1	B1		B1		B1		B2		B2	
Protection rating IP55/Type 12	B1		B1		B1		B2		B2	
Protection rating IP66/NEMA 4X	B1		B1		B1		B2		B2	
Output current										
Continuous (3x380–440 V) [A]	–	24	24	32	32	37.5	37.5	44	44	61
Intermittent (60 s overload) (3x380–440 V) [A]	–	26.4	38.4	35.2	51.2	41.3	60	48.4	70.4	67.1
Continuous (3x441–480 V) [A]	–	21	21	27	27	34	34	40	40	52
Intermittent (60 s overload) (3x441–480 V) [A]	–	23.1	33.6	29.7	43.2	37.4	54.4	44	64	61.6
Continuous kVA at 400 V [kVA]	–	16.6	16.6	22.2	22.2	26	26	30.5	30.5	42.3
Continuous kVA at 460 V [kVA]	–	16.7	16.7	21.5	21.5	27.1	27.1	31.9	31.9	41.4
Maximum input current										
Continuous (3x380–440 V) [A]	–	22	22	29	29	34	34	40	40	55
Intermittent (60 s overload) (3x380–440 V) [A]	–	24.2	35.2	31.9	46.4	37.4	54.4	44	64	60.5
Continuous (3x441–480 V) [A]	–	19	19	25	25	31	31	36	36	47
Intermittent (60 s overload) (3x441–480 V) [A]	–	20.9	30.4	27.5	40	34.1	49.6	39.6	57.6	51.7
Maximum pre-fuses [A]	–	63		63		63		63		80
Additional specifications										
Protection ratings IP21, IP55, IP66 maximum cable cross-section ²⁾ for mains, brake, and load sharing [mm ²] ([AWG])	16, 10, 16 (6, 8, 6)						35, –, – (2, –, –)			
Protection ratings IP21, IP55, IP66 maximum cable cross-section ²⁾ for motor [mm ²] ([AWG])	10, 10,– (8, 8,–)						35, 25, 25 (2, 4, 4)			
Protection rating IP20 maximum cable cross-section ²⁾ for mains, brake, motor, and load sharing [mm ²] ([AWG])	10, 10,– (8, 8,–)						35, –, – (2, –, –)			
Maximum cable cross-section ²⁾ for disconnect [mm ²] ([AWG])	16, 10, 10 (6, 8, 8)									
Estimated power loss ³⁾ at rated maximum load [W] ⁴⁾	291	392	291	392	379	465	444	525	547	739
Efficiency ⁵⁾	0.98		0.98		0.98		0.98		0.98	

Table 8.9 Mains Supply 3x380–480 V AC, P11K–P30K

Specifications

Type designation	P37K		P45K		P55K		P75K		P90K	
High/normal overload ¹⁾	HO	NO	HO	NO	HO	NO	HO	NO	HO	NO
Typical shaft output [kW]	30	37	37	45	45	55	55	75	75	90
Typical shaft output at 460 V [hp]	40	50	50	60	60	75	75	100	100	125
Protection rating IP20/Chassis ⁶⁾	B4		C3		C3		C4		C4	
Protection rating IP21/Type 1	C1		C1		C1		C2		C2	
Protection rating IP55/Type 12	C1		C1		C1		C2		C2	
Protection rating IP66/NEMA 4X	C1		C1		C1		C2		C2	
Output current										
Continuous (3x380–440 V) [A]	61	73	73	90	90	106	106	147	147	177
Intermittent (60 s overload) (3x380–440 V) [A]	91.5	80.3	110	99	135	117	159	162	221	195
Continuous (3x441–480 V) [A]	52	65	65	80	80	105	105	130	130	160
Intermittent (60 s overload) (3x441–480 V) [A]	78	71.5	97.5	88	120	116	158	143	195	176
Continuous kVA at 400 V [kVA]	42.3	50.6	50.6	62.4	62.4	73.4	73.4	102	102	123
Continuous kVA at 460 V [kVA]	41.4	51.8	51.8	63.7	63.7	83.7	83.7	104	103.6	128
Maximum input current										
Continuous (3x380–440 V) [A]	55	66	66	82	82	96	96	133	133	161
Intermittent (60 s overload) (3x380–440 V) [A]	82.5	72.6	99	90.2	123	106	144	146	200	177
Continuous (3x441–480 V) [A]	47	59	59	73	73	95	95	118	118	145
Intermittent (60 s overload) (3x441–480 V) [A]	70.5	64.9	88.5	80.3	110	105	143	130	177	160
Maximum pre-fuses [A]	100		125		160		250		250	
Additional specifications										
Protection rating IP20 maximum cable cross-section for mains and motor [mm ²] ([AWG])	35 (2)		50 (1)		50 (1)		150 (300 MCM)		150 (300 MCM)	
Protection rating IP20 maximum cable cross-section for brake and load sharing [mm ²] ([AWG])	35 (2)		50 (1)		50 (1)		95 (4/0)		95 (4/0)	
Protection ratings IP21, IP55, IP66 maximum cable cross-section for mains and motor [mm ²] ([AWG])	50 (1)		50 (1)		50 (1)		150 (300 MCM)		150 (300 MCM)	
Protection ratings IP21, IP55, IP66 maximum cable cross-section for brake and load sharing [mm ²] ([AWG])	50 (1)		50 (1)		50 (1)		95 (3/0)		95 (3/0)	
Maximum cable cross-section ²⁾ for mains disconnect [mm ²] ([AWG])			50, 35, 35 (1, 2, 2)				95, 70, 70 (3/0, 2/0, 2/0)		185, 150, 120 (350 MCM, 300 MCM, 4/0)	
Estimated power loss ³⁾ at rated maximum load [W] ⁴⁾	570	698	697	843	891	1083	1022	1384	1232	1474
Efficiency ⁵⁾	0.98		0.98		0.98		0.98		0.99	

Table 8.10 Mains Supply 3x380–480 V AC, P37K–P90K

Specifications

8.1.5 Mains Supply 3x525–600 V AC

Type designation	PK75		P1K1		P1K5		P2K2	
	HO	NO	HO	NO	HO	NO	HO	NO
High/normal overload ¹⁾	HO	NO	HO	NO	HO	NO	HO	NO
Typical shaft output [kW]	0.75		1.1		1.5		2.2	
Typical shaft output [hp]	1		1.5		2		3	
Protection rating IP20/Chassis	A3		A3		A3		A3	
Protection rating IP21/Type 1	A3		A3		A3		A3	
Protection rating IP55/Type 12	A5		A5		A5		A5	
Output current								
Continuous (3x525–550 V) [A]	1.8		2.6		2.9		4.1	
Intermittent (3x525–550 V) [A]	2.7	2.0	3.9	2.9	4.4	3.2	6.2	4.5
Continuous (3x551–600 V) [A]	1.7		2.4		2.7		3.9	
Intermittent (3x551–600 V) [A]	2.6	1.9	3.6	2.6	4.1	3.0	5.9	4.3
Continuous kVA at 550 V [kVA]	1.7		2.5		2.8		3.9	
Continuous kVA at 550 V [kVA]	1.7		2.4		2.7		3.9	
Maximum input current								
Continuous (3x525–600 V) [A]	1.7		2.4		2.7		4.1	
Intermittent (3x525–600 V) [A]	2.6	1.9	3.6	2.6	4.1	3.0	6.2	4.5
Maximum pre-fuses [A]	10		10		10		20	
Additional specifications								
Maximum cable cross-section ²⁾ for mains, motor, brake, and load sharing [mm ²] ([AWG])	4,4,4 (12,12,12) (minimum 0.2 (24))							
Maximum cable cross-section ²⁾ for mains disconnect [mm ²] ([AWG])	6,4,4 (10,12,12)							
Estimated power loss ³⁾ at rated maximum load [W] ⁴⁾	35		50		65		92	
Efficiency ⁵⁾	0.97		0.97		0.97		0.97	

Table 8.11 Mains Supply 3x525–600 V AC, PK75–P2K2

Specifications

Type designation	P3K0		P4K0		P5K5		P7K5	
High/normal overload ¹⁾	HO	NO	HO	NO	HO	NO	HO	NO
Typical shaft output [kW]	3.0		4.0		5.5		7.5	
Typical shaft output [hp]	4		5		7.5		10	
Protection rating IP20/Chassis Protection rating IP21/Type 1	A2		A2		A3		A3	
IP55/Type 12	A5		A5		A5		A5	
Output current								
Continuous (3x525–550 V) [A]	5.2		6.4		9.5		11.5	
Intermittent (3x525–550 V) [A]	7.8	5.7	9.6	7.0	14.3	10.5	17.3	12.7
Continuous (3x551–600 V) [A]	4.9		6.1		9.0		11.0	
Intermittent (3x551–600 V) [A]	7.4	5.4	9.2	6.7	13.5	9.9	16.5	12.1
Continuous kVA at 550 V [kVA]	5.0		6.1		9.0		11.0	
Continuous kVA at 550 V [kVA]	4.9		6.1		9.0		11.0	
Maximum input current								
Continuous (3x525–600 V) [A]	5.2		5.8		8.6		10.4	
Intermittent (3x525–600 V) [A]	7.8	5.7	8.7	6.4	12.9	9.5	15.6	11.4
Maximum pre-fuses [A]	20		20		32		32	
Additional specifications								
Maximum cable cross-section ²⁾ for mains, motor, brake, and load sharing [mm ²] ([AWG])	4,4,4 (12,12,12) (minimum 0.2 (24))							
Maximum cable cross-section ²⁾ for mains disconnect [mm ²] ([AWG])	6,4,4 (10,12,12)							
Estimated power loss ³⁾ at rated maximum load [W] ⁴⁾	122		145		195		261	
Efficiency ⁵⁾	0.97		0.97		0.97		0.97	

Table 8.12 Mains Supply 3x525–600 V AC, P3K0–P7K5

Specifications

Type designation	P11K		P15K		P18K		P22K		P30K		P37K	
High/normal overload ¹⁾	HO	NO	HO	NO	HO	NO	HO	NO	HO	NO	HO	NO
Typical shaft output [kW]	7.5	11	11	15	15	18.5	18.5	22	22	30	30	37
Typical shaft output [hp]	10	15	15	20	20	25	25	30	30	40	40	50
Protection rating IP20/ Chassis	B3		B3		B3		B4		B4		B4	
Protection rating IP21/ Type 1 Protection rating IP55/ Type 12 Protection rating IP66/ NEMA 4X	B1		B1		B1		B2		B2		C1	
Output current												
Continuous (3x525–550 V) [A]	11.5	19	19	23	23	28	28	36	36	43	43	54
Intermittent (3x525–550 V) [A]	18.4	21	30	25	37	31	45	40	58	47	65	59
Continuous (3x551–600 V) [A]	11	18	18	22	22	27	27	34	34	41	41	52
Intermittent (3x551–600 V) [A]	17.6	20	29	24	35	30	43	37	54	45	62	57
Continuous kVA at 550 V [kVA]	11	18.1	18.1	21.9	21.9	26.7	26.7	34.3	34.3	41.0	41.0	51.4
Continuous kVA at 575 V [kVA]	11	17.9	17.9	21.9	21.9	26.9	26.9	33.9	33.9	40.8	40.8	51.8
Maximum input current												
Continuous at 550 V [A]	10.4	17.2	17.2	20.9	20.9	25.4	25.4	32.7	32.7	39	39	49
Intermittent at 550 V [A]	16.6	19	28	23	33	28	41	36	52	43	59	54
Continuous at 575 V [A]	9.8	16	16	20	20	24	24	31	31	37	37	47
Intermittent at 575 V [A]	15.5	17.6	26	22	32	27	39	34	50	41	56	52
Maximum pre-fuses [A]	40		40		50		60		80		100	
Additional specifications												
Protection rating IP20, maximum cable cross- section ²⁾ for mains, brake, motor, and load sharing [mm ²] ([AWG])	10, 10,- (8, 8,-)						35,-,- (2,-,-)					
Protection ratings IP21, IP55, IP66 maximum cable cross-section ²⁾ for mains, brake, and load sharing [mm ²] ([AWG])	16, 10, 10 (6, 8, 8)						35,-,- (2,-,-)					
Protection ratings IP21, IP55, IP66 maximum cable cross-section ²⁾ for motor [mm ²] ([AWG])	10, 10,- (8, 8,-)						35, 25, 25 (2, 4, 4)					
Maximum cable cross- section ²⁾ for mains disconnect [mm ²] ([AWG])	16, 10, 10 (6, 8, 8)						50, 35, 35 (1, 2, 2)					
Estimated power loss ³⁾ at rated maximum load [W] ⁴⁾	220	300	220	300	300	370	370	440	440	600	600	740
Efficiency ⁵⁾	0.98		0.98		0.98		0.98		0.98		0.98	

Table 8.13 Mains supply 3x525–600 V AC, P11K–P37K

Specifications

Type designation	P45K		P55K		P75K		P90K	
High/normal overload ¹⁾	HO	NO	HO	NO	HO	NO	HO	NO
Typical shaft output [kW]	37	45	45	55	55	75	75	90
Typical shaft output [hp]	50	60	60	75	75	100	100	125
Protection rating IP20/Chassis	C3		C3		C4		C4	
Protection rating IP21/Type 1	C1		C1		C2		C2	
Protection rating IP55/Type 12	C1		C1		C2		C2	
Protection rating IP66/NEMA 4X	C1		C1		C2		C2	
Output current								
Continuous (3x525–550 V) [A]	54	65	65	87	87	105	105	137
Intermittent (3x525–550 V) [A]	81	72	98	96	131	116	158	151
Continuous (3x525–600 V) [A]	52	62	62	83	83	100	100	131
Intermittent (3x525–600 V) [A]	78	68	93	91	125	110	150	144
Continuous kVA at 525 V [kVA]	51.4	61.9	61.9	82.9	82.9	100	100.0	130.5
Continuous kVA at 575 V [kVA]	51.8	61.7	61.7	82.7	82.7	99.6	99.6	130.5
Maximum input current								
Continuous at 550 V [A]	49	59	59	78.9	78.9	95.3	95.3	124.3
Intermittent at 550 V [A]	74	65	89	87	118	105	143	137
Continuous at 575 V [A]	47	56	56	75	75	91	91	119
Intermittent at 575 V [A]	70	62	85	83	113	100	137	131
Maximum pre-fuses [A]	150		160		225		250	
Additional specifications								
Protection rating IP20 maximum cable cross-section for mains and motor [mm ²] ([AWG])	50 (1)			150 (300 MCM)				
Protection rating IP20 maximum cable cross-section for brake and load sharing [mm ²] ([AWG])	50 (1)			95 (4/0)				
Protection ratings IP21, IP55, IP66 maximum cable cross-section for mains and motor [mm ²] ([AWG])	50 (1)			150 (300 MCM)				
Protection ratings IP21, IP55, IP66 maximum cable cross-section for brake and load sharing [mm ²] ([AWG])	50 (1)			95 (4/0)				
Maximum cable cross-section ²⁾ for mains disconnect [mm ²] ([AWG])	50, 35, 35 (1, 2, 2)			95, 70, 70 (3/0, 2/0, 2/0)			185, 150, 120 (350 MCM, 300 MCM, 4/0)	
Estimated power loss ³⁾ at rated maximum load [W] ⁴⁾	740	900	900	1100	1100	1500	1500	1800
Efficiency ⁵⁾	0.98		0.98		0.98		0.98	

Table 8.14 Mains supply 3x525–600 V AC, P45K–P90K

Specifications

8.1.6 Mains Supply 3x525–690 V AC

Type designation	P1K1		P1K5		P2K2		P3K0		P4K0		P5K5		P7K5	
High/normal overload ¹⁾	HO	NO	HO	NO	HO	NO	HO	NO	HO	NO	HO	NO	HO	NO
Typical shaft output [kW]	1.1		1.5		2.2		3.0		4.0		5.5		7.5	
Typical shaft output [hp]	1.5		2		3		4		5		7.5		10	
IP20/Chassis	A3		A3		A3		A3		A3		A3		A3	
Output current														
Continuous (3x525–550 V) [A]	2.1		2.7		3.9		4.9		6.1		9.0		11.0	
Intermittent (3x525–550 V) [A]	3.2	2.3	4.1	3.0	5.9	4.3	7.4	5.4	9.2	6.7	13.5	9.9	16.5	12.1
Continuous (3x551–690 V) [A]	1.6		2.2		3.2		4.5		5.5		7.5		10.0	
Intermittent (3x551–690 V) [A]	2.4	1.8	3.3	2.4	4.8	3.5	6.8	5.0	8.3	6.1	11.3	8.3	15.0	11.0
Continuous kVA at 525 V [kVA]	1.9		2.5		3.5		4.5		5.5		8.2		10.0	
Continuous kVA at 690 V [kVA]	1.9		2.6		3.8		5.4		6.6		9.0		12.0	
Maximum input current														
Continuous (3x525–550 V) [A]	1.9		2.4		3.5		4.4		5.5		8.1		9.9	
Intermittent (3x525–550 V) [A]	2.9	2.1	3.6	2.6	5.3	3.9	6.6	4.8	8.3	6.1	12.2	8.9	14.9	10.9
Continuous (3x551–690 V) [A]	1.4		2.0		2.9		4.0		4.9		6.7		9.0	
Intermittent (3x551–690 V) [A]	2.1	1.5	3.0	2.2	4.4	3.2	6.0	4.4	7.4	5.4	10.1	7.4	13.5	9.9
Additional specifications														
Maximum cable cross-section ²⁾ for mains, motor, brake, and load sharing [mm ²] ([AWG])	4, 4, 4 (12, 12, 12) (min. 0.2 (24))													
Maximum cable cross-section ²⁾ for mains disconnect [mm ²] ([AWG])	6, 4, 4 (10, 12, 12)													
Estimated power loss ³⁾ at rated maximum load [W] ⁴⁾	44		60		88		120		160		220		300	
Efficiency ⁵⁾	0.96		0.96		0.96		0.96		0.96		0.96		0.96	

Table 8.15 A3 Enclosure, Mains Supply 3x525–690 V AC IP20/Protected Chassis, P1K1–P7K5

Specifications

Type designation	P11K		P15K		P18K		P22K		P30K	
High/normal overload ¹⁾	HO	NO	HO	NO	HO	NO	HO	NO	HO	NO
Typical shaft output at 550 V [kW]	5.9	7.5	7.5	11	11	15	15	18.5	18.5	22
Typical shaft output at 550 V [hp]	7.5	10	10	15	15	20	20	25	25	30
Typical shaft output at 690 V [kW]	7.5	11	11	15	15	18.5	18.5	22	22	30
Typical shaft output at 690 V [hp]	10	15	15	20	20	25	25	30	30	40
IP20/Chassis	B4		B4		B4		B4		B4	
IP21/Type 1										
IP55/Type 12	B2		B2		B2		B2		B2	
Output current										
Continuous (3x525–550 V) [A]	11	14	14.0	19.0	19.0	23.0	23.0	28.0	28.0	36.0
Intermittent (60 s overload) (3x525–550 V) [A]	17.6	15.4	22.4	20.9	30.4	25.3	36.8	30.8	44.8	39.6
Continuous (3x551–690 V) [A]	10	13	13.0	18.0	18.0	22.0	22.0	27.0	27.0	34.0
Intermittent (60 s overload) (3x551–690 V) [A]	16	14.3	20.8	19.8	28.8	24.2	35.2	29.7	43.2	37.4
Continuous kVA at 550 V [kVA]	10	13.3	13.3	18.1	18.1	21.9	21.9	26.7	26.7	34.3
Continuous kVA at 690 V [kVA]	12	15.5	15.5	21.5	21.5	26.3	26.3	32.3	32.3	40.6
Maximum input current										
Continuous at 550 V [A]	9.9	15	15.0	19.5	19.5	24.0	24.0	29.0	29.0	36.0
Intermittent (60 s overload) at 550 V [A]	15.8	16.5	23.2	21.5	31.2	26.4	38.4	31.9	46.4	39.6
Continuous (at 690 V) [A]	9	14.5	14.5	19.5	19.5	24.0	24.0	29.0	29.0	36.0
Intermittent (60 s overload) at 690 V [A]	14.4	16	23.2	21.5	31.2	26.4	38.4	31.9	46.4	39.6
Additional specifications										
Maximum cable cross-section ²⁾ for mains, motor, brake, and load sharing [mm ²] ([AWG])	35, 25, 25 (2, 4, 4)									
Maximum cable cross-section ²⁾ for mains disconnect [mm ²] ([AWG])	16,10,10 (6, 8, 8)									
Estimated power loss ³⁾ at rated maximum load [W] ⁴⁾	150	220	150	220	220	300	300	370	370	440
Efficiency ⁵⁾	0.98		0.98		0.98		0.98		0.98	

Table 8.16 B2/B4 Enclosure, Mains Supply 3x525–690 V AC IP20/IP21/IP55 – Chassis/NEMA 1/NEMA 12, P11K–P22K

Specifications

Type designation	P37K		P45K		P55K		P75K/N75K ⁸⁾		P90K/N90K ⁸⁾	
High/normal overload ¹⁾	HO	NO	HO	NO	HO	NO	HO	NO	HO	NO
Typical shaft output at 550 V [kW]	22	30	30	37	37	45	45	55	55	75
Typical shaft output at 550 V [hp]	30	40	40	50	50	60	60	75	75	100
Typical shaft output at 690 V [kW]	30	37	37	45	45	55	55	75	75	90
Typical shaft output at 690 V [hp]	40	50	50	60	60	75	75	100	199	125
IP20/Chassis	B4		C3		C3		D3h		D3h	
IP21/Type 1										
IP55/Type 12	C2		C2		C2		C2		C2	
Output current										
Continuous (3x525–550 V) [A]	36.0	43.0	43.0	54.0	54.0	65.0	65.0	87.0	87.0	105
Intermittent (60 s overload) (3x525–550 V) [A]	54.0	47.3	64.5	59.4	81.0	71.5	97.5	95.7	130.5	115.5
Continuous (3x551–690 V) [A]	34.0	41.0	41.0	52.0	52.0	62.0	62.0	83.0	83.0	100
Intermittent (60 s overload) (3x551–690 V) [A]	51.0	45.1	61.5	57.2	78.0	68.2	93.0	91.3	124.5	110
Continuous kVA at 550 V [kVA]	34.3	41.0	41.0	51.4	51.4	61.9	61.9	82.9	82.9	100
Continuous kVA at 690 V [kVA]	40.6	49.0	49.0	62.1	62.1	74.1	74.1	99.2	99.2	119.5
Maximum input current										
Continuous at 550 V [A]	36.0	49.0	49.0	59.0	59.0	71.0	71.0	87.0	87.0	99.0
Intermittent (60 s overload) at 550 V [A]	54.0	53.9	72.0	64.9	87.0	78.1	105.0	95.7	129	108.9
Continuous at 690 V [A]	36.0	48.0	48.0	58.0	58.0	70.0	70.0	86.0	–	–
Intermittent (60 s overload) at 690 V [A]	54.0	52.8	72.0	63.8	87.0	77.0	105	94.6	–	–
Additional specifications										
Maximum cable cross-section for mains and motor [mm ²] ([AWG])	150 (300 MCM)									
Maximum cable cross-section for brake and load sharing [mm ²] ([AWG])	95 (3/0)									
Maximum cable cross-section ²⁾ for mains disconnect [mm ²] ([AWG])	95 (3/0)						185, 150, 120 (350 MCM, 300 MCM, 4/0)		–	
Estimated power loss ³⁾ at rated maximum load [W] ⁴⁾	600	740	740	900	900	1100	1100	1500	1500	1800
Efficiency ⁵⁾	0.98		0.98		0.98		0.98		0.98	

Table 8.17 B4, C2, C3 Enclosure, Mains Supply 3x525–690 V AC IP20/IP21/IP55 – Chassis/NEMA1/NEMA 12, P30K–P75K

For fuse ratings see chapter 8.8 Fuses and Circuit Breakers.

1) High overload=150% or 160% torque for a duration of 60 s. Normal overload=110% torque for a duration of 60 s.

2) The 3 values for the maximum cable cross-section are for single core, flexible wire and flexible wire with sleeve, respectively.

3) Applies for dimensioning of frequency converter cooling. If the switching frequency is higher than the default setting, the power losses may increase. LCP and typical control card power consumptions are included.

4) Efficiency measured at nominal current. For energy efficiency class see chapter 8.4.1 Ambient Conditions.

5) Measured using 5 m screened motor cables at rated load and rated frequency.

6) Enclosure sizes A2+A3 can be converted to IP21 using a conversion kit. See also Mechanical mounting and IP21/Type 1 Enclosure kit in the design guide.

7) Enclosure sizes B3+B4 and C3+C4 can be converted to IP21 using a conversion kit. See also Mechanical mounting and IP21/Type 1 Enclosure kit in the design guide.

8) Enclosure sizes for N75K, N90K are D3h for IP20/Chassis, and D5h for IP54/Type 12.

9) Two wires are required.

10) Variant not available in IP21.

Specifications

8.2 Mains Supply

Mains supply (L1, L2, L3)

Supply voltage	200–240 V \pm 10%
Supply voltage	380–480 V \pm 10%
Supply voltage	525–600 V \pm 10%
Supply voltage	525–690 V \pm 10%

Mains voltage low/mains drop-out:

During low mains voltage or a mains drop-out, the frequency converter continues until the intermediate circuit voltage drops below the minimum stop level. Typically this corresponds to 15% below the lowest rated supply voltage of the frequency converter. Power-up and full torque cannot be expected at mains voltage <10% below the lowest rated supply voltage of the frequency converter.

Supply frequency	50/60 Hz +4/-6%
------------------	-----------------

The frequency converter power supply is tested in accordance with IEC61000-4-28, 50 Hz +4/-6%.

Maximum imbalance temporary between mains phases	3.0% of rated supply voltage
True power factor (λ)	\geq 0.9 nominal at rated load
Displacement power factor ($\cos\phi$) near unity	(>0.98)
Switching on input supply L1, L2, L3 (power-ups) \leq 7.5 kW	maximum 2 times/min.
Switching on input supply L1, L2, L3 (power-ups) 11–90 kW	maximum 1 time/min.
Environment according to EN 60664-1	overvoltage category III/pollution degree 2

The unit is suitable for use on a circuit capable of delivering not more than 100000 RMS symmetrical Amperes, 240/480/600/690 V maximum.

8

8.3 Motor Output and Motor Data

Motor output (U, V, W)

Output voltage	0–100% of supply voltage
Output frequency	0–590 Hz ¹⁾
Switching on output	Unlimited
Ramp times	1–3600 s

1) Dependent on power size.

Torque characteristics, normal overload

Starting torque (constant torque)	maximum 110% for 1 minute, once in 10 minutes ²⁾
Overload torque (constant torque)	maximum 110% for 1 minute, once in 10 minutes ²⁾

Torque characteristics, high overload

Starting torque (constant torque)	maximum 150/160% for 1 minute, once in 10 minutes ²⁾
Overload torque (constant torque)	maximum 150/160% for 1 minute, once in 10 minutes ²⁾

2) Percentage relates to the nominal torque of the frequency converter, dependent on power size.

Specifications

8.4 Ambient Conditions

Environment

Enclosure size A	IP20/Chassis, IP21/Type 1, IP55/Type 12, IP66/Type 4X
Enclosure size B1/B2	IP21/Type 1, IP55/Type 12, IP66/Type 4X
Enclosure size B3/B4	IP20/Chassis
Enclosure size C1/C2	IP21/Type 1, IP55/Type 12, IP66/Type 4X
Enclosure size C3/C4	IP20/Chassis
Enclosure kit available ≤ enclosure size A	IP21/TYP 1/IP4X top
Vibration test enclosure A/B/C	1.0 g
Maximum relative humidity	5–95% (IEC 721-3-3; Class 3K3 (non-condensing) during operation
Aggressive environment (IEC 721-3-3), uncoated	class 3C2
Aggressive environment (IEC 721-3-3), coated	class 3C3
Test method according to IEC 60068-2-43 H2S (10 days)	
Ambient temperature	Maximum 50 °C

Derating for high ambient temperature, see section on special conditions in the Design Guide.

Minimum ambient temperature during full-scale operation	0 °C
Minimum ambient temperature at reduced performance	-10 °C
Temperature during storage/transport	-25 to +65/70 °C
Maximum altitude above sea level without derating	1000 m
Maximum altitude above sea level with derating	3000 m

Derating for high altitude, see section on special conditions in the Design Guide.

EMC standards, Emission	EN 61800-3
EMC standards, Immunity	EN 61800-3
Energy efficiency class ¹⁾	IE2

1) Determined according to EN50598-2 at:

- Rated load
- 90% rated frequency
- Switching frequency factory setting
- Switching pattern factory setting

8.5 Cable Specifications

Maximum motor cable length, screened/armoured	150 m
Maximum motor cable length, unscreened/unarmoured	300 m
Maximum cross section to motor, mains, load sharing and brake ¹⁾	
Maximum cross section to control terminals, rigid wire	1.5 mm ² /16 AWG (2 x 0.75 mm ²)
Maximum cross section to control terminals, flexible cable	1 mm ² /18 AWG
Maximum cross section to control terminals, cable with enclosed core	0.5 mm ² /20 AWG
Minimum cross section to control terminals	0.25 mm ²

1) See electrical data tables in chapter 8.1 Electrical Data for more information.

It is mandatory to ground the mains connection properly using T95 (PE) of the frequency converter. The ground connection cable cross section must be at least 10 mm² or 2 rated mains wires terminated separately according to EN 50178. See also chapter 4.3.1 Grounding. Use unscreened cable.

8.6 Control Input/Output and Control Data

Control card, RS485 serial communication

Terminal number	68 (PTX+, RX+), 69 (NTX-, RX-)
Terminal number 61	common for terminals 68 and 69

The RS485 serial communication circuit is functionally separated from other central circuits and galvanically isolated from the supply voltage (PELV).

Specifications

Analog inputs

Number of analog inputs	2
Terminal number	53, 54
Modes	voltage or current
Mode select	switches S201 and S202
Voltage mode	switch S201/S202 = OFF (U)
Voltage level	0-10 V (scaleable)
Input resistance, R_i	approximately 10 k Ω
Maximum voltage	± 20 V
Current mode	switch S201/S202=On (I)
Current level	0/4-20 mA (scaleable)
Input resistance, R_i	approximately 200 Ω
Maximum current	30 mA
Resolution for analog inputs	10 bit (+ sign)
Accuracy of analog inputs	maximum error 0.5% of full scale
Bandwidth	200 Hz

The analog inputs are galvanically isolated from the supply voltage (PELV) and other high-voltage terminals.

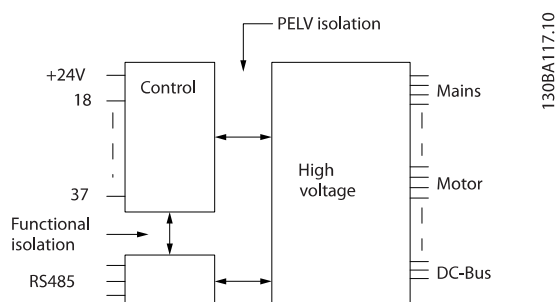

Illustration 8.1 PELV Isolation of Analog Inputs

Analog output

Number of programmable analog outputs	1
Terminal number	42
Current range at analog output	0/4–20 mA
Maximum resistor load to common at analog output	500 Ω
Accuracy on analog output	maximum error 0.8% of full scale
Resolution on analog output	8 bit

The analog output is galvanically isolated from the supply voltage (PELV) and other high-voltage terminals.

Digital inputs

Programmable digital inputs	4 (6)
Terminal number	18, 19, 27 ¹⁾ , 29 ¹⁾ , 32, 33,
Logic	PNP or NPN
Voltage level	0–24 V DC
Voltage level, logic 0 PNP	<5 V DC
Voltage level, logic 1 PNP	>10 V DC
Voltage level, logic 0 NPN	>19 V DC
Voltage level, logic '1' NPN	<14 V DC
Maximum voltage on input	28 V DC
Input resistance, R_i	approximately 4 k Ω

All digital inputs are galvanically isolated from the supply voltage (PELV) and other high-voltage terminals.

1) Terminals 27 and 29 can also be programmed as output.

Specifications

Digital output

Programmable digital/pulse outputs	2
Terminal number	27, 29 ¹⁾
Voltage level at digital/frequency output	0–24 V
Maximum output current (sink or source)	40 mA
Maximum load at frequency output	1 k Ω
Maximum capacitive load at frequency output	10 nF
Minimum output frequency at frequency output	0 Hz
Maximum output frequency at frequency output	32 kHz
Accuracy of frequency output	maximum error 0.1% of full scale
Resolution of frequency outputs	12 bit

1) Terminal 27 and 29 can also be programmed as input.

The digital output is galvanically isolated from the supply voltage (PELV) and other high-voltage terminals.

Pulse inputs

Programmable pulse inputs	2
Terminal number pulse	29, 33
Maximum frequency at terminal 29, 33	110 kHz (push-pull driven)
Maximum frequency at terminal 29, 33	5 kHz (open collector)
Minimum frequency at terminal 29, 33	4 Hz
Voltage level	see <i>Digital inputs</i>
Maximum voltage on input	28 V DC
Input resistance, R_i	approx. 4 k Ω
Pulse input accuracy (0.1–1 kHz)	maximum error 0.1% of full scale

Control card, 24 V DC output

Terminal number	12, 13
Maximum load	200 mA

The 24 V DC supply is galvanically isolated from the supply voltage (PELV), but has the same potential as the analog and digital inputs and outputs.

Relay outputs

Programmable relay outputs	2
Relay 01 terminal number	1-3 (break), 1-2 (make)
Maximum terminal load (AC-1) ¹⁾ on 1-3 (NC), 1-2 (NO) (resistive load)	240 V AC, 2 A
Maximum terminal load (AC-15) ¹⁾ (inductive load @ $\cos\phi$ 0.4)	240 V AC, 0.2 A
Maximum terminal load (DC-1) ¹⁾ on 1-2 (NO), 1-3 (NC) (resistive load)	60 V DC, 1 A
Maximum terminal load (DC-13) ¹⁾ (inductive load)	24 V DC, 0.1 A
Relay 02 terminal number	4-6 (break), 4-5 (make)
Maximum terminal load (AC-1) ¹⁾ on 4-5 (NO) (resistive load) ^{2) 3)}	400 V AC, 2 A
Maximum terminal load (AC-15) ¹⁾ on 4-5 (NO) (inductive load @ $\cos\phi$ 0.4)	240 V AC, 0.2 A
Maximum terminal load (DC-1) ¹⁾ on 4-5 (NO) (resistive load)	80 V DC, 2 A
Maximum terminal load (DC-13) ¹⁾ on 4-5 (NO) (inductive load)	24 V DC, 0.1 A
Maximum terminal load (AC-1) ¹⁾ on 4-6 (NC) (resistive load)	240 V AC, 2 A
Maximum terminal load (AC-15) ¹⁾ on 4-6 (NC) (inductive load @ $\cos\phi$ 0.4)	240 V AC, 0.2 A
Maximum terminal load (DC-1) ¹⁾ on 4-6 (NC) (resistive load)	50 V DC, 2 A
Maximum terminal load (DC-13) ¹⁾ on 4-6 (NC) (inductive load)	24 V DC, 0.1 A
Minimum terminal load on 1-3 (NC), 1-2 (NO), 4-6 (NC), 4-5 (NO)	24 V DC, 10 mA, 24 V AC, 20 mA
Environment according to EN 60664-1	overvoltage category III/pollution degree 2

1) IEC 60947 parts 4 and 5.

The relay contacts are galvanically isolated from the rest of the circuit by reinforced isolation (PELV).

2) Overvoltage category II.

3) UL applications 300 V AC 2 A.

Specifications

Control card, 10 V DC output

Terminal number	50
Output voltage	10.5 V \pm 0.5 V
Maximum load	25 mA

The 10 V DC supply is galvanically isolated from the supply voltage (PELV) and other high-voltage terminals.

Control characteristics

Resolution of output frequency at 0–590 Hz	\pm 0.003 Hz
System response time (terminals 18, 19, 27, 29, 32, 33)	\leq 2 ms
Speed control range (open loop)	1:100 of synchronous speed
Speed accuracy (open loop)	30–4000 RPM: maximum error of \pm 8 RPM

All control characteristics are based on a 4-pole asynchronous motor.

Control card performance

Scan interval	5 ms
---------------	------

Control card, USB serial communication

USB standard	1.1 (full speed)
USB plug	USB type B “device” plug

CAUTION

Connection to a PC is carried out via a standard host/device USB cable.

The USB connection is galvanically isolated from the supply voltage (PELV) and other high-voltage terminals.

The USB connection is not galvanically isolated from protective earth. Use only an isolated laptop/PC as a connection to the USB connector on the frequency converter, or an isolated USB cable/converter.

8

8.7 Connection Tightening Torques

Enclosure	Torque [Nm]					
	Mains	Motor	DC connection	Brake	Ground	Ground
A2	1.8	1.8	1.8	1.8	3	0.6
A3	1.8	1.8	1.8	1.8	3	0.6
A4	1.8	1.8	1.8	1.8	3	0.6
A5	1.8	1.8	1.8	1.8	3	0.6
B1	1.8	1.8	1.5	1.5	3	0.6
B2	4.5	4.5	3.7	3.7	3	0.6
B3	1.8	1.8	1.8	1.8	3	0.6
B4	4.5	4.5	4.5	4.5	3	0.6
C1	10	10	10	10	3	0.6
C2	14/24 ¹⁾	14/24 ¹⁾	14	14	3	0.6
C3	10	10	10	10	3	0.6
C4	14/24 ¹⁾	14/24 ¹⁾	14	14	3	0.6

Table 8.18 Terminal Tightening Torques

1) For different cable dimensions x/y, where $x \leq 95 \text{ mm}^2$ and $y \geq 95 \text{ mm}^2$.

8.8 Fuses and Circuit Breakers

Use recommended fuses and/or circuit breakers on the supply side as protection in case of component break-down inside the frequency converter (first fault).

NOTICE

Use of fuses on the supply side is mandatory for IEC 60364 (CE) and NEC 2009 (UL) compliant installations.

Recommendations:

- gG type fuses.
- Moeller type circuit breakers. For other circuit breaker types, ensure that the energy into the frequency converter is equal to or lower than the energy provided by Moeller types.

Use of recommended fuses and circuit breakers ensures that possible damage to the frequency converter is limited to damages inside the unit. For further information, see *Application Note Fuses and Circuit Breakers*.

The fuses in *chapter 8.8.1 CE Compliance* to *chapter 8.8.2 UL Compliance* are suitable for use on a circuit capable of delivering 100000 A_{rms} (symmetrical), depending on the frequency converter voltage rating. With the proper fusing, the frequency converter short-circuit current rating (SCCR) is 100000 A_{rms} .

8.8.1 CE Compliance

200–240 V, Enclosure sizes A, B, and C

Enclosure	Power [kW]	Recommended fuse size	Recommended maximum fuse	Recommended circuit breaker Moeller	Maximum trip level [A]
A2	0.25–2.2	gG-10 (0.25–1.5) gG-16 (2.2)	gG-25	PKZM0-25	25
A3	3.0–3.7	gG-16 (3) gG-20 (3.7)	gG-32	PKZM0-25	25
A4	0.25–2.2	gG-10 (0.25–1.5) gG-16 (2.2)	gG-32	PKZM0-25	25
A5	0.25–3.7	gG-10 (0.25–1.5) gG-16 (2.2–3) gG-20 (3.7)	gG-32	PKZM0-25	25
B1	5.5–11	gG-25 (5.5) gG-32 (7.5)	gG-80	PKZM4-63	63
B2	15	gG-50	gG-100	NZMB1-A100	100
B3	5.5–11	gG-25	gG-63	PKZM4-50	50
B4	15–18	gG-32 (7.5) gG-50 (11) gG-63 (15)	gG-125	NZMB1-A100	100
C1	18.5–30	gG-63 (15) gG-80 (18.5) gG-100 (22)	gG-160 (15–18.5) aR-160 (22)	NZMB2-A200	160
C2	37–45	aR-160 (30) aR-200 (37)	aR-200 (30) aR-250 (37)	NZMB2-A250	250
C3	22–30	gG-80 (18.5) aR-125 (22)	gG-150 (18.5) aR-160 (22)	NZMB2-A200	150
C4	37–45	aR-160 (30) aR-200 (37)	aR-200 (30) aR-250 (37)	NZMB2-A250	250

Table 8.19 200–240 V, Enclosure Sizes A, B, and C

Specifications

380–480 V, Enclosure Sizes A, B, and C

Enclosure	Power [kW]	Recommended fuse size	Recommended maximum fuse	Recommended circuit breaker Moeller	Maximum trip level [A]
A2	1.1–4.0	gG-10 (0.37-3) gG-16 (4)	gG-25	PKZM0-25	25
A3	5.5–7.5	gG-16	gG-32	PKZM0-25	25
A4	1.1–4.0	gG-10 (0.37-3) gG-16 (4)	gG-32	PKZM0-25	25
A5	1.1–7.5	gG-10 (0.37-3) gG-16 (4-7.5)	gG-32	PKZM0-25	25
B1	11–18.5	gG-40	gG-80	PKZM4-63	63
B2	22–30	gG-50 (18.5) gG-63 (22)	gG-100	NZMB1-A100	100
B3	11–18	gG-40	gG-63	PKZM4-50	50
B4	22–37	gG-50 (18.5) gG-63 (22) gG-80 (30)	gG-125	NZMB1-A100	100
C1	37–55	gG-80 (30) gG-100 (37) gG-160 (45)	gG-160	NZMB2-A200	160
C2	75–90	aR-200 (55) aR-250 (75)	aR-250	NZMB2-A250	250
C3	45–55	gG-100 (37) gG-160 (45)	gG-150 (37) gG-160 (45)	NZMB2-A200	150
C4	75–90	aR-200 (55) aR-250 (75)	aR-250	NZMB2-A250	250

Table 8.20 380–480 V, Enclosure Sizes A, B, and C

Specifications

525–600 V, Enclosure Sizes A, B, and C

Enclosure	Power [kW]	Recommended fuse size	Recommended maximum fuse	Recommended circuit breaker Moeller	Maximum trip level [A]
A2	1.1–4.0	gG-10	gG-25	PKZM0-25	25
A3	5.5–7.5	gG-10 (5.5) gG-16 (7.5)	gG-32	PKZM0-25	25
A5	1.1–7.5	gG-10 (0.75-5.5) gG-16 (7.5)	gG-32	PKZM0-25	25
B1	11–18	gG-25 (11) gG-32 (15) gG-40 (18.5)	gG-80	PKZM4-63	63
B2	22–30	gG-50 (22) gG-63 (30)	gG-100	NZMB1-A100	100
B3	11–18.5	gG-25 (11) gG-32 (15)	gG-63	PKZM4-50	50
B4	22–37	gG-40 (18.5) gG-50 (22) gG-63 (30)	gG-125	NZMB1-A100	100
C1	37–55	gG-63 (37) gG-100 (45) aR-160 (55)	gG-160 (37-45) aR-250 (55)	NZMB2-A200	160
C2	75–90	aR-200 (75)	aR-250	NZMB2-A250	250
C3	45–55	gG-63 (37) gG-100 (45)	gG-150	NZMB2-A200	150
C4	75–90	aR-160 (55) aR-200 (75)	aR-250	NZMB2-A250	250

Table 8.21 525–600 V, Enclosure Sizes A, B, and C

525-690 V, Enclosure Sizes A, B, and C

Enclosure	Power [kW]	Recommended fuse size	Recommended maximum fuse	Recommended circuit breaker KSB	Maximum trip level [A]
A3	1.1	gG-6	gG-25	CTI25M 10-16	16
	1.5	gG-6	gG-25	CTI25M 10-16	16
	2.2	gG-6	gG-25	CTI25M 10-16	16
	3	gG-10	gG-25	CTI25M 10-16	16
	4	gG-10	gG-25	CTI25M 10-16	16
	5.5	gG-16	gG-25	CTI25M 10-16	16
	7.5	gG-16	gG-25	CTI25M 10-16	16
B2	11	gG-25	gG-63		
	15	gG-25	gG-63		
	18	gG-32			
	22	gG-32			
C2	30	gG-40			
	37	gG-63	gG-80		
	45	gG-63	gG-100		
	55	gG-80	gG-125		
	75	gG-100	gG-160		
C3	37	gG-100	gG-125		
	45	gG-125	gG-160		

Table 8.22 525–690 V, Enclosure Sizes A, B, and C

8.8.2 UL Compliance

1x200–240 V, Enclosure Sizes A, B, and C

Recommended maximum fuse													
Power [kW]	Max. pre-fuse size [A]	Bussmann JFHR2	Bussmann RK1	Bussmann J	Bussmann T	Bussmann CC	Bussmann CC	Bussmann CC	SIBA RK1	Littel fuse RK1	Ferraz-Shawmut CC	Ferraz-Shawmut RK1	Ferraz-Shawmut J
1.1	15	FWX-15	KTN-R15	JKS-15	JJN-15	FNQ-R-15	KTK-R-15	LP-CC-15	5017906-016	KLN-R15	ATM-R15	A2K-15R	HSJ15
1.5	20	FWX-20	KTN-R20	JKS-20	JJN-20	FNQ-R-20	KTK-R-20	LP-CC-20	5017906-020	KLN-R20	ATM-R20	A2K-20R	HSJ20
2.2	30 ¹⁾	FWX-30	KTN-R30	JKS-30	JJN-30	FNQ-R-30	KTK-R-30	LP-CC-30	5012406-032	KLN-R30	ATM-R30	A2K-30R	HSJ30
3.0	35	FWX-35	KTN-R35	JKS-35	JJN-35	–	–	–	–	KLN-R35	–	A2K-35R	HSJ35
3.7	50	FWX-50	KTN-R50	JKS-50	JJN-50	–	–	–	5014006-050	KLN-R50	–	A2K-50R	HSJ50
5.5	60 ²⁾	FWX-60	KTN-R60	JKS-60	JJN-60	–	–	–	5014006-063	KLN-R60	–	A2K-60R	HSJ60
7.5	80	FWX-80	KTN-R80	JKS-80	JJN-80	–	–	–	5014006-080	KLN-R80	–	A2K-80R	HSJ80
15	150	FWX-150	KTN-R150	JKS-150	JJN-150	–	–	–	2028220-150	KLN-R150	–	A2K-150R	HSJ150
22	200	FWX-200	KTN-R200	JKS-200	JJN-200	–	–	–	2028220-200	KLN-R200	–	A2K-200R	HSJ200

Table 8.23 1x200–240 V, Enclosure Sizes A, B, and C

1) Siba allowed up to 32 A.

2) Siba allowed up to 63 A.

1x380–500 V, Enclosure Sizes B and C

Recommended maximum fuse													
Power [kW]	Max. pre-fuse size [A]	Bussmann JFHR2	Bussmann RK1	Bussmann J	Bussmann T	Bussmann CC	Bussmann CC	Bussmann CC	SIBA RK1	Littel fuse RK1	Ferraz-Shawmut CC	Ferraz-Shawmut RK1	Ferraz-Shawmut J
7.5	60	FWH-60	KTS-R60	JKS-60	JJS-60	–	–	–	5014006-063	KLS-R60	–	A6K-60R	HSJ60
11	80	FWH-80	KTS-R80	JKS-80	JJS-80	–	–	–	2028220-100	KLS-R80	–	A6K-80R	HSJ80
22	150	FWH-150	KTS-R150	JKS-150	JJS-150	–	–	–	2028220-160	KLS-R150	–	A6K-150R	HSJ150
37	200	FWH-200	KTS-R200	JKS-200	JJS-200	–	–	–	2028220-200	KLS-200	–	A6K-200R	HSJ200

Table 8.24 1x380–500 V, Enclosure Sizes B and C

- KTS-fuses from Bussmann may substitute KTN for 240 V frequency converters.
- FWH-fuses from Bussmann may substitute FWX for 240 V frequency converters.
- JJS-fuses from Bussmann may substitute JJN for 240 V frequency converters.
- KLSR fuses from Littel fuse may substitute KLN-R fuses for 240 V frequency converters.
- A6KR fuses from Ferraz-Shawmut may substitute A2KR for 240 V frequency converters.

Specifications

3x200–240 V, Enclosure Sizes A, B, and C

Power [kW]	Recommended maximum fuse					
	Bussmann Type RK1 ¹⁾	Bussmann Type J	Bussmann Type T	Bussmann Type CC	Bussmann	Bussmann Type CC
0.25–0.37	KTN-R-05	JKS-05	JJN-05	FNQ-R-5	KTK-R-5	LP-CC-5
0.55–1.1	KTN-R-10	JKS-10	JJN-10	FNQ-R-10	KTK-R-10	LP-CC-10
1.5	KTN-R-15	JKS-15	JJN-15	FNQ-R-15	KTK-R-15	LP-CC-15
2.2	KTN-R-20	JKS-20	JJN-20	FNQ-R-20	KTK-R-20	LP-CC-20
3.0	KTN-R-25	JKS-25	JJN-25	FNQ-R-25	KTK-R-25	LP-CC-25
3.7	KTN-R-30	JKS-30	JJN-30	FNQ-R-30	KTK-R-30	LP-CC-30
5.5–7.5	KTN-R-50	JKS-50	JJN-50	–	–	–
11	KTN-R-60	JKS-60	JJN-60	–	–	–
15	KTN-R-80	JKS-80	JJN-80	–	–	–
18.5–22	KTN-R-125	JKS-125	JJN-125	–	–	–
30	KTN-R-150	JKS-150	JJN-150	–	–	–
37	KTN-R-200	JKS-200	JJN-200	–	–	–
45	KTN-R-250	JKS-250	JJN-250	–	–	–

Table 8.25 3x200–240 V, Enclosure Sizes A, B, and C

Power [kW]	Recommended maximum fuse							
	SIBA Type RK1	Littel fuse Type RK1	Ferraz-Shawmut Type CC	Ferraz-Shawmut Type RK1 ²⁾	Bussmann Type JFHR2 ³⁾	Littel fuse JFHR2	Ferraz-Shawmut JFHR2 ⁴⁾	Ferraz-Shawmut J
0.25–0.37	5017906-005	KLN-R-05	ATM-R-05	A2K-05-R	FWX-5	–	–	HSJ-6
0.55–1.1	5017906-010	KLN-R-10	ATM-R-10	A2K-10-R	FWX-10	–	–	HSJ-10
1.5	5017906-016	KLN-R-15	ATM-R-15	A2K-15-R	FWX-15	–	–	HSJ-15
2.2	5017906-020	KLN-R-20	ATM-R-20	A2K-20-R	FWX-20	–	–	HSJ-20
3.0	5017906-025	KLN-R-25	ATM-R-25	A2K-25-R	FWX-25	–	–	HSJ-25
3.7	5012406-032	KLN-R-30	ATM-R-30	A2K-30-R	FWX-30	–	–	HSJ-30
5.5–7.5	5014006-050	KLN-R-50	–	A2K-50-R	FWX-50	–	–	HSJ-50
11	5014006-063	KLN-R-60	–	A2K-60-R	FWX-60	–	–	HSJ-60
15	5014006-080	KLN-R-80	–	A2K-80-R	FWX-80	–	–	HSJ-80
18.5–22	2028220-125	KLN-R-125	–	A2K-125-R	FWX-125	–	–	HSJ-125
30	2028220-150	KLN-R-150	–	A2K-150-R	FWX-150	L25S-150	A25X-150	HSJ-150
37	2028220-200	KLN-R-200	–	A2K-200-R	FWX-200	L25S-200	A25X-200	HSJ-200
45	2028220-250	KLN-R-250	–	A2K-250-R	FWX-250	L25S-250	A25X-250	HSJ-250

Table 8.26 3x200–240 V, Enclosure Sizes A, B, and C

- 1) KTS-fuses from Bussmann may substitute KTN for 240 V frequency converters.
- 2) A6KR fuses from Ferraz-Shawmut may substitute A2KR for 240 V frequency converters.
- 3) FWH-fuses from Bussmann may substitute FWX for 240 V frequency converters.
- 4) A50X fuses from Ferraz-Shawmut may substitute A25X for 240 V frequency converters.

Specifications

3x380–480 V, Enclosure Sizes A, B, and C

Power [kW]	Recommended maximum fuse					
	Bussmann Type RK1	Bussmann Type J	Bussmann Type T	Bussmann Type CC	Bussmann Type CC	Bussmann Type CC
-	KTS-R-6	JKS-6	JJS-6	FNQ-R-6	KTK-R-6	LP-CC-6
1.1–2.2	KTS-R-10	JKS-10	JJS-10	FNQ-R-10	KTK-R-10	LP-CC-10
3	KTS-R-15	JKS-15	JJS-15	FNQ-R-15	KTK-R-15	LP-CC-15
4	KTS-R-20	JKS-20	JJS-20	FNQ-R-20	KTK-R-20	LP-CC-20
5.5	KTS-R-25	JKS-25	JJS-25	FNQ-R-25	KTK-R-25	LP-CC-25
7.5	KTS-R-30	JKS-30	JJS-30	FNQ-R-30	KTK-R-30	LP-CC-30
11	KTS-R-40	JKS-40	JJS-40	-	-	-
15	KTS-R-50	JKS-50	JJS-50	-	-	-
22	KTS-R-60	JKS-60	JJS-60	-	-	-
30	KTS-R-80	JKS-80	JJS-80	-	-	-
37	KTS-R-100	JKS-100	JJS-100	-	-	-
45	KTS-R-125	JKS-125	JJS-125	-	-	-
55	KTS-R-150	JKS-150	JJS-150	-	-	-
75	KTS-R-200	JKS-200	JJS-200	-	-	-
90	KTS-R-250	JKS-250	JJS-250	-	-	-

Table 8.27 3x380–480 V, Enclosure Sizes A, B, and C

Power [kW]	Recommended maximum fuse							
	SIBA Type RK1	Littel fuse Type RK1	Ferraz-Shawmut Type CC	Ferraz-Shawmut Type RK1	Bussmann JFHR2	Ferraz-Shawmut J	Ferraz-Shawmut JFHR2 ¹⁾	Littel fuse JFHR2
-	5017906-006	KLS-R-6	ATM-R-6	A6K-6-R	FWH-6	HSJ-6	-	-
1.1–2.2	5017906-010	KLS-R-10	ATM-R-10	A6K-10-R	FWH-10	HSJ-10	-	-
3	5017906-016	KLS-R-15	ATM-R-15	A6K-15-R	FWH-15	HSJ-15	-	-
4	5017906-020	KLS-R-20	ATM-R-20	A6K-20-R	FWH-20	HSJ-20	-	-
5.5	5017906-025	KLS-R-25	ATM-R-25	A6K-25-R	FWH-25	HSJ-25	-	-
7.5	5012406-032	KLS-R-30	ATM-R-30	A6K-30-R	FWH-30	HSJ-30	-	-
11	5014006-040	KLS-R-40	-	A6K-40-R	FWH-40	HSJ-40	-	-
15	5014006-050	KLS-R-50	-	A6K-50-R	FWH-50	HSJ-50	-	-
22	5014006-063	KLS-R-60	-	A6K-60-R	FWH-60	HSJ-60	-	-
30	2028220-100	KLS-R-80	-	A6K-80-R	FWH-80	HSJ-80	-	-
37	2028220-125	KLS-R-100	-	A6K-100-R	FWH-100	HSJ-100	-	-
45	2028220-125	KLS-R-125	-	A6K-125-R	FWH-125	HSJ-125	-	-
55	2028220-160	KLS-R-150	-	A6K-150-R	FWH-150	HSJ-150	-	-
75	2028220-200	KLS-R-200	-	A6K-200-R	FWH-200	HSJ-200	A50-P-225	L50-S-225
90	2028220-250	KLS-R-250	-	A6K-250-R	FWH-250	HSJ-250	A50-P-250	L50-S-250

Table 8.28 3x380–480 V, Enclosure Sizes A, B, and C

1) Ferraz-Shawmut A50QS fuses may substitute A50P fuses.

Specifications

3x525–600 V, Enclosure Sizes A, B, and C

Power [kW]	Recommended maximum fuse									
	Bussmann Type RK1	Bussmann Type J	Bussmann Type T	Bussmann Type CC	Bussmann Type CC	Bussmann Type CC	SIBA Type RK1	Littel fuse Type RK1	Ferraz-Shawmut Type RK1	Ferraz-Shawmut J
0.75–1.1	KTS-R-5	JKS-5	JJS-6	FNQ-R-5	KTK-R-5	LP-CC-5	5017906-005	KLS-R-005	A6K-5-R	HSJ-6
1.5–2.2	KTS-R-10	JKS-10	JJS-10	FNQ-R-10	KTK-R-10	LP-CC-10	5017906-010	KLS-R-010	A6K-10-R	HSJ-10
3	KTS-R-15	JKS-15	JJS-15	FNQ-R-15	KTK-R-15	LP-CC-15	5017906-016	KLS-R-015	A6K-15-R	HSJ-15
4	KTS-R-20	JKS-20	JJS-20	FNQ-R-20	KTK-R-20	LP-CC-20	5017906-020	KLS-R-020	A6K-20-R	HSJ-20
5.5	KTS-R-25	JKS-25	JJS-25	FNQ-R-25	KTK-R-25	LP-CC-25	5017906-025	KLS-R-025	A6K-25-R	HSJ-25
7.5	KTS-R-30	JKS-30	JJS-30	FNQ-R-30	KTK-R-30	LP-CC-30	5017906-030	KLS-R-030	A6K-30-R	HSJ-30
11–15	KTS-R-35	JKS-35	JJS-35	–	–	–	5014006-040	KLS-R-035	A6K-35-R	HSJ-35
18	KTS-R-45	JKS-45	JJS-45	–	–	–	5014006-050	KLS-R-045	A6K-45-R	HSJ-45
22	KTS-R-50	JKS-50	JJS-50	–	–	–	5014006-050	KLS-R-050	A6K-50-R	HSJ-50
30	KTS-R-60	JKS-60	JJS-60	–	–	–	5014006-063	KLS-R-060	A6K-60-R	HSJ-60
37	KTS-R-80	JKS-80	JJS-80	–	–	–	5014006-080	KLS-R-075	A6K-80-R	HSJ-80
45	KTS-R-100	JKS-100	JJS-100	–	–	–	5014006-100	KLS-R-100	A6K-100-R	HSJ-100
55	KTS-R-125	JKS-125	JJS-125	–	–	–	2028220-125	KLS-R-125	A6K-125-R	HSJ-125
75	KTS-R-150	JKS-150	JJS-150	–	–	–	2028220-150	KLS-R-150	A6K-150-R	HSJ-150
90	KTS-R-175	JKS-175	JJS-175	–	–	–	2028220-200	KLS-R-175	A6K-175-R	HSJ-175

Table 8.29 3x525–600 V, Enclosure Sizes A, B, and C

3x525–690 V, Enclosure Sizes B and C

Power [kW]	Maximum pre-fuse [A]	Recommended maximum fuse						
		Bussmann E52273 RK1/JDDZ	Bussmann E4273 J/JDDZ	Bussmann E4273 T/JDDZ	SIBA E180276 RK1/JDDZ	LittelFuse E81895 RK1/JDDZ	Ferraz-Shawmut E163267/E2137 RK1/JDDZ	Ferraz-Shawmut E2137 J/HSJ
11–15	30	KTS-R-30	JKS-30	JJS-30	5017906-030	KLS-R-030	A6K-30-R	HST-30
22	45	KTS-R-45	JKS-45	JJS-45	5014006-050	KLS-R-045	A6K-45-R	HST-45
30	60	KTS-R-60	JKS-60	JJS-60	5014006-063	KLS-R-060	A6K-60-R	HST-60
37	80	KTS-R-80	JKS-80	JJS-80	5014006-080	KLS-R-075	A6K-80-R	HST-80
45	90	KTS-R-90	JKS-90	JJS-90	5014006-100	KLS-R-090	A6K-90-R	HST-90
55	100	KTS-R-100	JKS-100	JJS-100	5014006-100	KLS-R-100	A6K-100-R	HST-100
75	125	KTS-R-125	JKS-125	JJS-125	2028220-125	KLS-150	A6K-125-R	HST-125
90	150	KTS-R-150	JKS-150	JJS-150	2028220-150	KLS-175	A6K-150-R	HST-150

Table 8.30 3x525–690 V, Enclosure Sizes B and C

Specifications

8.9 Power Ratings, Weight, and Dimensions

Enclosure size [kW]		A2		A3		A4	A5
3x525-690 V	T7	–	–	–	–	–	–
3x525-600 V	T6	–	–	0.75–7.5	–	–	0.75–7.5
3x380-480 V	T4	0.37–4.0	–	5.5–7.5	–	0.37–4.0	0.37–7.5
1x380-480 V	S4	–	–	–	–	1.1–4.0	–
3x200-240 V	T2	0.25–3.0	–	3.7	–	0.25–2.2	0.25–3.7
1x200-240 V	S2	–	–	1.1	–	1.1–2.2	1.1
IP		20	21	20	21	55/66	55/66
NEMA		Chassis	Type 1	Chassis	Type 1	Type 12/4X	Type 12/4X
Height [mm]							
Height of back plate	A ¹⁾	268	375	268	375	390	420
Height with de-coupling plate for fieldbus cables	A	374	–	374	–	–	–
Distance between mounting holes	a	257	350	257	350	401	402
Width [mm]							
Width of back plate	B	90	90	130	130	200	242
Width of back plate with 1 C option	B	130	130	170	170	–	242
Width of back plate with 2 C options	B	90	90	130	130	–	242
Distance between mounting holes	b	70	70	110	110	171	215
Depth²⁾ [mm]							
Without option A/B	C	205	205	205	205	175	200
With option A/B	C	220	220	220	220	175	200
Screw holes [mm]							
	c	8.0	8.0	8.0	8.0	8.25	8.2
	d	ø11	ø11	ø11	ø11	ø12	ø12
	e	ø5.5	ø5.5	ø5.5	ø5.5	ø6.5	ø6.5
	f	9	9	9	9	6	9
Maximum weight [kg]		4.9	5.3	6.6	7.0	9.7	14
1) See <i>Illustration 3.4</i> and <i>Illustration 3.5</i> for top and bottom mounting holes.							
2) Depth of enclosure will vary with different options installed.							

Table 8.31 Power Ratings, Weight, and Dimensions, Enclosure Sizes A2-A5

Specifications

Enclosure size [kW]		B1	B2	B3	B4	C1	C2	C3	C4
3x525-690 V	T7	–	11–30	–	–	–	37–90	–	–
3x525-600 V	T6	11–18.5	22–30	11–18.5	22–37	37–55	75–90	45–55	75–90
3x380-480 V	T4	11–18.5	22–30	11–18.5	22–37	37–55	75–90	45–55	75–90
1x380-480 V	S4	7.5	11	–	–	18	37	–	–
3x200-240 V	T2	5.5–11	15	5.5–11	15–18.5	18.5–30	37–45	22–30	37–45
1x200-240 V	S2	1.5–3.7	7.5	–	–	15	22	–	–
IP		21/55/66	21/55/66	20	20	21/55/66	21/55/66	20	20
NEMA		Type 1/12/4X	Type 1/12/4X	Chassis	Chassis	Type 1/12/4X	Type 1/12/4X	Chassis	Chassis
Height [mm]									
Height of back plate	A ¹⁾	480	650	399	520	680	770	550	660
Height with de-coupling plate for fieldbus cables	A	–	–	419	595	–	–	630	800
Distance between mounting holes	a	454	624	380	495	648	739	521	631
Width [mm]									
Width of back plate	B	242	242	165	231	308	370	308	370
Width of back plate with 1 C option	B	242	242	205	231	308	370	308	370
Width of back plate with 2 C options	B	242	242	165	231	308	370	308	370
Distance between mounting holes	b	210	210	140	200	272	334	270	330
Depth²⁾ [mm]									
Without option A/B	C	260	260	248	242	310	335	333	333
With option A/B	C	260	260	262	242	310	335	333	333
Screw holes [mm]									
	c	12	12	8	–	12	12	–	–
	d	ø19	ø19	12	–	ø19	ø19	–	–
	e	ø9	ø9	6.8	8.5	ø9.0	ø9.0	8.5	8.5
	f	9	9	7.9	15	9.8	9.8	17	17
Maximum weight [kg]		23	27	12	23.5	45	65	35	50
1) See <i>Illustration 3.4</i> and <i>Illustration 3.5</i> for top and bottom mounting holes.									
2) Depth of enclosure will vary with different options installed.									

Table 8.32 Power Ratings, Weight, and Dimensions, Enclosure Sizes B1-B4, C1-C4

9 Appendix

9.1 Symbols, Abbreviations, and Conventions

°C	Degrees celsius
AC	Alternating current
AEO	Automatic energy optimization
AWG	American wire gauge
AMA	Automatic motor adaptation
DC	Direct current
EMC	Electro magnetic compatibility
ETR	Electronic thermal relay
$f_{M,N}$	Nominal motor frequency
FC	Frequency converter
I_{INV}	Rated inverter output current
I_{LIM}	Current limit
$I_{M,N}$	Nominal motor current
$I_{VLT,MAX}$	Maximum output current
$I_{VLT,N}$	Rated output current supplied by the frequency converter
IP	Ingress protection
LCP	Local control panel
MCT	Motion control tool
n_s	Synchronous motor speed
$P_{M,N}$	Nominal motor power
PELV	Protective extra low voltage
PCB	Printed circuit board
PM Motor	Permanent magnet motor
PWM	Pulse width modulation
RPM	Revolutions per minute
Regen	Regenerative terminals
T_{LIM}	Torque limit
$U_{M,N}$	Nominal motor voltage

Table 9.1 Symbols and Abbreviations

Conventions

Numbered lists indicate procedures.

Bullet lists indicate other information.

Italicised text indicates:

- Cross reference.
- Link.
- Parameter name.

All dimensions are in [mm].

9.2 Parameter Menu Structure

Appendix

0-0*	Operation / Display	1-03 Torque Characteristics	1-80 Function at Stop	3-93 Maximum Limit	5-53 Term. 29 High Ref./Feedb. Value
0-0*	Basic Settings	1-06 Clockwise Direction	1-81 Min Speed for Function at Stop [RPM]	3-94 Minimum Limit	5-54 Pulse Filter Time Constant #29
0-01	Language	1-1* Motor Selection	1-82 Min Speed for Function at Stop [Hz]	3-95 Ramp Delay	5-55 Term. 33 Low Frequency
0-02	Motor Speed Unit	1-10 Motor Construction	1-86 Trip Speed Low [RPM]	4-1* Limits / Warnings	5-56 Term. 33 High Frequency
0-03	Regional Settings	1-1* VVC+ PM	1-87 Trip Speed Low [Hz]	4-1* Motor Limits	5-57 Term. 33 Low Ref./Feedb. Value
0-04	Operating State at Power-up	Damping Gain	1-9* Motor Temperature	4-10 Motor Speed Direction	5-58 Term. 33 High Ref./Feedb. Value
0-05	Local Mode Unit	1-15 Low Speed Filter Time Const.	1-90 Motor Thermal Protection	5-59 Pulse Output	5-6* Pulse Output
0-1*	Set-up Operations	1-16 High Speed Filter Time Const.	1-91 Motor External Fan	5-60 Terminal 27 Pulse Output Variable	5-62 Pulse Output Max Freq #27
0-10	Active Set-up	1-17 Voltage filter time const.	1-93 Thermistor Source	5-63 Terminal 29 Pulse Output Variable	5-65 Pulse Output Max Freq #29
0-11	Programming Set-up	1-2* Motor Data	2-0* Brakes	5-66 Terminal X30/6 Pulse Output Variable	5-68 Pulse Output Max Freq #X30/6
0-12	This Set-up Linked to	1-20 Motor Power [kW]	2-00 DC Brake	5-8* I/O Options	5-80 AHF Cap Reconnect Delay
0-13	Readout: Linked Set-ups	1-21 Motor Power [HP]	2-00 DC Hold/Preheat Current	5-9* Bus Controlled	5-90 Digital & Relay Bus Control
0-14	Readout: Prog. Set-ups / Channel	1-22 Motor Voltage	2-01 DC Brake Current	5-94 Pulse Out #27 Bus Control	5-93 Pulse Out #27 Timeout Preset
0-2*	LCP Display	1-23 Motor Frequency	2-02 DC Braking Time	5-95 Pulse Out #29 Bus Control	5-96 Pulse Out #29 Timeout Preset
0-20	Display Line 1.1 Small	1-24 Motor Current	2-03 DC Brake Cut In Speed [RPM]	5-97 Pulse Out #X30/6 Bus Control	5-98 Pulse Out #X30/6 Timeout Preset
0-21	Display Line 1.2 Small	1-25 Motor Nominal Speed	2-04 DC Brake Cut In Speed [Hz]	6-0* Analog In/Out	6-0* Analog I/O Mode
0-22	Display Line 1.3 Small	1-26 Motor Cont. Rated Torque	2-06 Parking Current	6-00 Live Zero Timeout Time	6-01 Live Zero Timeout Function
0-23	Display Line 2 Large	1-28 Motor Rotation Check	2-07 Parking Time	6-01 Analog Input 53	6-10 Terminal 53 Low Voltage
0-24	Display Line 3 Large	1-29 Automatic Motor Adaptation (AMA)	2-1* Brake Energy Funct.	6-11 Terminal 53 High Voltage	6-12 Terminal 53 Low Current
0-25	My Personal Menu	1-3* Adv. Motor Data	2-10 Brake Function	6-14 Terminal 53 Low Ref./Feedb. Value	6-15 Terminal 53 High Ref./Feedb. Value
0-3*	LCP Custom Readout	1-30 Stator Resistance (Rs)	2-11 Brake Resistor (ohm)	6-16 Terminal 53 Filter Time Constant	6-17 Terminal 53 Live Zero
0-30	Custom Readout Unit	1-31 Rotor Resistance (Rr)	2-12 Brake Power Limit (kW)	6-2* Analog Input 54	6-20 Terminal 54 Low Voltage
0-31	Custom Readout Min Value	1-33 Stator Leakage Reactance (X1)	2-13 Brake Power Monitoring	6-20 Terminal 54 High Voltage	6-21 Terminal 54 High Current
0-32	Custom Readout Max Value	1-34 Rotor Leakage Reactance (X2)	2-15 Brake Check	6-22 Terminal 54 Low Current	6-23 Terminal 54 High Current
0-37	Display Text 1	1-35 Main Reactance (Xh)	2-16 AC brake Max. Current	6-24 Terminal 54 High Ref./Feedb. Value	6-25 Terminal 54 High Ref./Feedb. Value
0-38	Display Text 2	1-36 Iron Loss Resistance (Rfe)	2-17 Over-voltage Control	6-26 Terminal 54 Filter Time Constant	6-27 Terminal 54 Live Zero
0-39	Display Text 3	1-37 d-axis Inductance (Ld)	2-19 Over-voltage Gain	6-3* Analog Input X30/11	6-30 Terminal X30/11 Low Voltage
0-4*	LCP Keypad	1-38 Max. q-axis Inductance Lq	3-0* Reference / Ramps	6-31 Terminal X30/11 High Voltage	6-34 Term. X30/11 Low Ref./Feedb. Value
0-40	[Hand on] Key on LCP	1-39 Motor Poles	3-02 Minimum Reference	6-36 Term. X30/11 Live Zero	6-37 Term. X30/11 Live Zero
0-41	[Off] Key on LCP	1-40 Back EMF at 1000 RPM	3-03 Maximum Reference	6-40 Terminal X30/12 Low Voltage	6-41 Terminal X30/12 High Voltage
0-42	[Auto on] Key on LCP	1-41 Min. d-axis Inductance Ld	3-04 Reference Function	6-41 Term. X30/12 Low Ref./Feedb. Value	6-45 Term. X30/12 High Ref./Feedb. Value
0-43	[Reset] Key on LCP	1-45 Min. q-axis Inductance Ld	3-1* References	6-46 Term. X30/12 Filter Time Constant	
0-44	[Off/Reset] Key on LCP	1-46 Position Detection Gain	3-10 Preset Reference		
0-45	[Drive Bypass] Key on LCP	1-48 Saturation point of Ld in % of IN	3-11 Jog Speed [Hz]		
0-5*	Copy/Save	1-5* Load Indep. Setting	3-13 Reference Site		
0-50	LCP Copy	1-50 Motor Magnetisation at Zero Speed	3-14 Preset Relative Reference		
0-51	Set-up Copy	1-51 Min Speed Normal Magnetising [RPM]	3-15 Reference 1 Source		
0-6*	Password	1-52 Min Speed Normal Magnetising [Hz]	3-16 Reference 2 Source		
0-60	Main Menu Password	1-55 V/f Characteristic - v	3-17 Reference 3 Source		
0-61	Access to Main Menu w/o Password	1-56 V/f Characteristic - f	3-19 Jog Speed [RPM]		
0-65	Personal Menu Password	1-58 Flystart Test Pulses Current	3-4* Ramp 1		
0-66	Access to Personal Menu w/o Password	1-59 Flystart Test Pulses Frequency	3-41 Ramp 1 Ramp Up Time		
0-67	Bus Password Access	1-60 Load Depen. Setting	3-42 Ramp 1 Ramp Down Time		
0-7*	Clock Settings	1-60 Low Speed Load Compensation	3-5* Ramp 2		
0-70	Date and Time	1-61 High Speed Load Compensation	3-51 Ramp 2 Ramp Up Time		
0-71	Date Format	1-62 Slip Compensation	3-52 Ramp 2 Ramp Down Time		
0-72	Time Format	1-63 Slip Compensation Time Constant	3-8* Other Ramps		
0-74	DST/Summertime	1-64 Resonance Dampening	3-80 Jog Ramp Time		
0-76	DST/Summertime Start	1-65 Resonance Dampening Time Constant	3-81 Quick Stop Ramp Time		
0-77	DST/Summertime End	1-66 Min. Current at Low Speed	3-84 Initial Ramp Time		
0-79	Clock Fault	1-7* Start Adjustments	3-85 Check Valve Ramp Time		
0-81	Working Days	1-70 PM Start Mode	3-86 Check Valve Ramp End Speed [RPM]		
0-82	Additional Working Days	1-71 Start Delay	3-88 Final Ramp Time		
0-83	Additional Non-Working Days	1-72 Start Function	3-9* Digital Pot./Meter		
0-89	Date and Time Readout	1-73 Flying Start	3-90 Step Size		
1-0*	Load and Motor	1-74 Start Speed [RPM]	3-91 Ramp Time		
1-0*	General Settings	1-75 Start Speed [Hz]	3-92 Power Restore		
1-00	Configuration Mode	1-76 Start Current			
1-01	Motor Control Principle	1-8* Stop Adjustments			

Appendix

6-47	Term. X30/12 Live Zero	8-90	Bus Jog 1 Speed	10-23	COS Filter 4	12-98	Interface Counters	14-6*	Auto Derate
6-50	Terminal 42 Output	8-91	Bus Jog 2 Speed	10-3*	Parameter Access	12-99	Media Counters	14-60	Function at Over Temperature
6-51	Terminal 42 Output Min Scale	8-94	Bus Feedback 1	10-30	Array Index	13-3*	Smart Logic	14-61	Function at Inverter Overload
6-52	Terminal 42 Output Max Scale	8-95	Bus Feedback 2	10-31	Store Data Values	13-0*	SLC Settings	14-62	Inv. Overload Derate Current
6-53	Terminal 42 Output Bus Control	8-96	Bus Feedback 3	10-32	Deviacen Revision	13-00	SL Controller Mode	14-8*	Options
6-54	Terminal 42 Output Timeout Preset	9-**	PRODrive	10-33	Store Always	13-01	Start Event	14-80	Option Supplied by External 24VDC
6-55	Terminal 42 Output Filter	9-00	Setpoint	10-34	DeviacenNet Product Code	13-02	Stop Event	14-9*	Fault Settings
6-6*	Analog Output X30/8	9-07	Actual Value	10-39	DeviacenNet F Parameters	13-03	Reset SLC	14-90	Fault Level
6-60	Terminal X30/8 Output	9-15	PCD Write Configuration	12-**	Ethernet	13-1*	Comparators	15-**	Drive Information
6-61	Terminal X30/8 Min. Scale	9-16	PCD Read Configuration	12-0*	IP Settings	13-10	Comparator Operand	15-0*	Operating Data
6-62	Terminal X30/8 Max. Scale	9-18	Node Address	12-00	IP Address Assignment	13-11	Comparator Operator	15-00	Operating Hours
6-63	Terminal X30/8 Output Bus Control	9-22	Telegram Selection	12-01	IP Address	13-12	Comparator Value	15-01	Running Hours
6-64	Terminal X30/8 Output Timeout Preset	9-23	Parameters for Signals	12-02	Subnet Mask	13-2*	Timers	15-02	kWh Counter
8-**	Comm. and Options	9-27	Parameter Edit	12-03	Default Gateway	13-20	SL Controller Timer	15-03	Power Ups
8-0*	General Settings	9-28	Process Control	12-04	DHCP Server	13-4*	Logic Rules	15-04	Over Temp's
8-01	Control Site	9-31	Safe Address	12-05	Lease Expires	13-40	Logic Rule Boolean 1	15-05	Over Volt's
8-02	Control Source	9-44	Fault Message Counter	12-06	Name Servers	13-41	Logic Rule Operator 1	15-06	Reset kWh Counter
8-03	Control Timeout Time	9-45	Fault Code	12-07	Domain Name	13-42	Logic Rule Boolean 2	15-07	Reset Running Hours Counter
8-04	Control Timeout Function	9-52	Fault Situation Counter	12-08	Host Name	13-43	Logic Rule Operator 2	15-08	Number of Starts
8-05	End-of-Timeout Function	9-53	Profibus Warning Word	12-09	Physical Address	13-44	Logic Rule Boolean 3	15-1*	Data Log Settings
8-06	Reset Control Timeout	9-63	Actual Baud Rate	12-1*	Ethernet Link Parameters	13-5*	States	15-10	Logging Source
8-07	Diagnosis Trigger	9-64	Device Identification	12-10	Link Status	13-51	SL Controller Event	15-11	Logging Interval
8-08	Readout Filtering	9-65	Profile Number	12-11	Link Duration	13-52	SL Controller Action	15-12	Trigger Event
8-1*	Control Settings	9-67	Control Word 1	12-12	Auto Negotiation	14-0*	Special Functions	15-13	Logging Mode
8-10	Control Profile	9-68	Status Word 1	12-13	Link Speed	14-0*	Inverter Switching	15-14	Samples Before Trigger
8-13	Configurable Status Word STW	9-71	Profibus Save Data Values	12-2*	Process Data	14-01	Switching Frequency	15-2*	Historic Log
8-14	Configurable Control Word CTW	9-72	ProfibusDriveReset	12-21	Control Instance	14-03	Overmodulation	15-20	Historic Log: Event
8-30	Protocol	9-75	DO Identification	12-22	Process Data Config Write	14-03	PWM Random	15-21	Historic Log: Value
8-31	Address	9-80	Defined Parameters (1)	12-28	Process Data Config Read	14-04	Deadtime Compensation	15-22	Historic Log: Time
8-32	Baud Rate	9-81	Defined Parameters (2)	12-29	Primary Master	14-06	Mains On/Off	15-23	Historic log: Date and Time
8-33	Parity / Stop Bits	9-82	Defined Parameters (3)	12-30	Warning Parameter	14-1*	Mains Failure	15-3*	Alarm Log
8-35	Minimum Response Delay	9-83	Defined Parameters (4)	12-31	Net Reference	14-10	Mains Voltage at Mains Fault	15-30	Alarm Log: Error Code
8-36	Max Response Delay	9-84	Defined Parameters (5)	12-32	Net Control	14-11	Function at Mains Imbalance	15-31	Alarm Log: Value
8-37	Maximum Inter-Char Delay	9-90	Changed Parameters (1)	12-33	CIP Revision	14-12	Reset Functions	15-32	Alarm Log: Time
8-4*	FC MC protocol set	9-91	Changed Parameters (2)	12-34	CIP Product Code	14-2*	Current Limit Ctrl.	15-33	Alarm Log: Date and Time
8-40	Telegram Selection	9-92	Changed Parameters (3)	12-35	EDS Parameter	14-20	Reset Mode	15-34	Alarm Log: Setpoint
8-42	PCD Write Configuration	9-93	Changed Parameters (4)	12-37	COS Inhibit Timer	14-21	Automatic Restart Time	15-35	Alarm Log: Feedback
8-43	PCD Read Configuration	9-94	Changed Parameters (5)	12-38	COS Filter	14-22	Operation Mode	15-36	Alarm Log: Current Demand
8-5*	Digital/Bus	10-**	CAN Fieldbus	12-3*	EtherNet/IP	14-25	Typecode Setting	15-37	Alarm Log: Process Ctrl Unit
8-50	Coasting Select	10-0*	Common Settings	12-30	Warning Parameter	14-26	Trip Delay at Torque Limit	15-4*	Drive Identification
8-52	DC Brake Select	10-00	CAN Protocol	12-38	COS Filter	14-28	Trip Delay at Inverter Fault	15-40	FC Type
8-53	Start Select	10-01	Baud Rate Select	12-40	Status Parameter	14-29	Production Settings	15-41	Power Section
8-54	Reversing Select	10-02	MAC ID	12-41	Slave Message Count	14-29	Service Code	15-42	Voltage
8-55	Set-up Select	10-05	Readout Transmit Error Counter	12-42	Slave Exception Message Count	14-3*	Current Limit Ctrl.	15-43	Software Version
8-56	Preset Reference Select	10-06	Readout Receive Error Counter	12-8*	Other Ethernet Services	14-30	Current Lim Ctrl, Proportional Gain	15-44	Ordered Typecode String
8-7*	BACnet	10-07	Readout Bus Off Counter	12-80	FTP Server	14-31	Current Lim Ctrl, Integration Time	15-45	Actual Typecode String
8-70	BACnet Device Instance	10-1*	DeviceNet	12-81	HTTP Server	14-32	Current Lim Ctrl, Filter Time	15-46	Frequency Converter Ordering No
8-72	M5/TP Max Masters	10-10	Process Data Type Selection	12-82	SMTP Service	14-4*	Energy Optimising	15-47	Power Card Ordering No
8-73	M5/TP Max Info Frames	10-11	Process Data Config Write	12-88	Transparent Socket Channel Port	14-40	VT Level	15-48	LCP Id No
8-74	"I-Am" Service	10-12	Process Data Config Read	12-89	Advanced Ethernet Services	14-41	AEO Minimum Magnetisation	15-49	SW ID Control Card
8-75	Initialisation Password	10-13	Warning Parameter	12-90	Cable Diagnostic	14-42	Minimum AEO Frequency	15-50	SW ID Power Card
8-8*	FC Port Diagnostics	10-14	Net Reference	12-91	MDI-X	14-43	Motor Cosphi	15-51	Frequency Converter Serial Number
8-80	Bus Message Count	10-15	Net Control	12-92	IGMP Snooping	14-5*	Environment	15-53	Power Card Serial Number
8-81	Bus Error Count	10-2*	COS Filters	12-93	Cable Error Length	14-50	RFI Filter	15-59	CSIV Filename
8-82	Slave Message Rcvd	10-20	Slave Message Rcvd	12-94	Broadcast Storm Protection	14-51	DC Link Compensation	15-6*	Option Ident
8-83	Slave Error Count	10-21	COS Filter 1	12-95	Broadcast Storm Filter	14-52	Fan Control	15-60	Option Mounted
8-9*	Bus Jog / Feedback	10-22	COS Filter 2	12-96	Port Mirroring	14-53	Fan Monitor	15-61	Option SW Version
			COS Filter 3			14-55	Output Filter	15-62	Option Ordering No
						14-59	Actual Number of Inverter Units	15-63	Option Serial No

Appendix

15-70	Option in Slot A	22-75	Short Cycle Protection
15-71	Slot A Option SW Version	22-76	Interval between Starts
15-72	Option in Slot B	22-77	Minimum Run Time
15-73	Slot B Option SW Version	22-78	Minimum Run Time Override
15-74	Option in Slot C0/E0	22-79	Minimum Run Time Override Value
15-75	Slot C0/E0 Option SW Version	22-8*	Flow Compensation (DFS)
15-76	Option in Slot C1/E1	22-80	Flow Compensation (DFS)
15-77	Slot C1/E1 Option SW Version	22-81	Square-linear Curve Approximation
15-9*	Parameter Info	22-82	Work Point Calculation
15-92	Defined Parameters	22-83	Speed at No-Flow [RPM]
15-93	Modified Parameters	22-84	Speed at No-Flow [RPM]
15-98	Drive Identification	22-85	Speed at Design Point [RPM]
15-99	Parameter Metadata	22-86	Speed at Design Point [Hz]
16-0*	Data Readouts	22-87	Pressure at No-Flow Speed
16-00	General Status	22-88	Pressure at Rated Speed
16-01	Control Word	22-89	Flow at Design Point
16-02	Reference [Unit]	22-90	Flow at Rated Speed
16-03	Reference [%]	23-0*	Time-based Functions
16-05	Status Word	23-01	ON Time
16-05	Main Actual Value [%]	23-02	OFF Time
16-09	Custom Readout	23-03	OFF Action
16-1*	Motor Status	23-04	Occurrence
16-10	Power [kW]	23-1*	Maintenance
16-11	Power [hp]	23-10	Maintenance Item
16-12	Motor Voltage	23-11	Maintenance Action
16-13	Frequency	23-12	Maintenance Time Base
16-14	Motor current	23-13	Maintenance Time Interval
16-15	Frequency [%]	23-14	Maintenance Date and Time
16-16	Torque [Nm]	23-15	Reset Maintenance Word
16-17	Speed [RPM]	23-16	Maintenance Text
16-18	Motor Thermal	23-5*	Energy Log
16-20	Motor Angle	23-50	Energy Log Resolution
16-22	Torque [%]	23-51	Period Start
16-30	Drive Status	23-53	Energy Log
16-30	DC Link Voltage	23-54	Reset Energy Log
16-32	Brake Energy /s	23-6*	Trending
16-33	Brake Energy /2 min	23-60	Trend Variable
16-34	Heatsink Temp.	23-61	Continuous Bin Data
16-35	Inverter Thermal	23-62	Timed Bin Data
16-36	Inv. Nom. Current	23-63	Timed Period Start
16-37	Inv. Max. Current	23-64	Timed Period Stop
16-38	SL Controller State	23-65	Minimum Bin Value
16-39	Control Card Temp.	23-66	Reset Continuous Bin Data
16-40	Logging Buffer Full	23-67	Reset Timed Bin Data
16-49	Current Fault Source	23-8*	Payback Counter
16-5*	Ref. & Feeds.	23-80	Power Reference Factor
16-50	External Reference	23-81	Energy Cost
16-52	Feedback[Unit]	23-82	Investment
16-53	Digi Pot Reference	23-83	Energy Savings
16-54	Feedback 1 [Unit]	23-84	Cost Savings
16-55	Feedback 2 [Unit]	24-0*	Appl. Functions 2
16-56	Feedback 3 [Unit]	24-1*	Drive Bypass
16-56	Feedback 3 [Unit]	24-10	Drive Bypass Delay Time
16-58	PID Output [%]	24-11	Drive Bypass Delay Time
16-58	Adjusted Setpoint		
16-6*	Inputs & Outputs		
16-60	Digital Input		
16-61	Terminal 53 Switch Setting		
16-62	Analog Input 53		
16-63	Terminal 54 Switch Setting		
20-20	Feedback Function	21-42	Ext. 2 Integral Time
20-21	Setpoint 1	21-43	Ext. 2 Differentiation Time
20-22	Setpoint 2	21-44	Ext. 2 Dif. Gain Limit
20-23	Setpoint 3	21-5*	Ext. CL 3 Ref./Fb.
20-70	Closed Loop Type	21-50	Ext. 3 Ref./Feedback Unit
20-71	PID Performance	21-51	Ext. 3 Minimum Reference
20-72	PID Output Change	21-52	Ext. 3 Maximum Reference
20-73	Minimum Feedback Level	21-53	Ext. 3 Reference Source
20-74	Maximum Feedback Level	21-54	Ext. 3 Feedback Source
20-79	PID Autotuning	21-55	Ext. 3 Setpoint
20-8*	PID Basic Settings	21-57	Ext. 3 Reference [Unit]
20-81	PID Normal/ Inverse Control	21-58	Ext. 3 Feedback [Unit]
20-82	PID Start Speed [RPM]	21-59	Ext. 3 Output [%]
20-83	PID Start Speed [Hz]	21-6*	Ext. CL 3 PID
20-84	On Reference Bandwidth	21-60	Ext. 3 Normal/Inverse Control
20-9*	PID Controller	21-61	Ext. 3 Proportional Gain
20-91	PID Anti Windup	21-62	Ext. 3 Integral Time
20-93	PID Proportional Gain	21-63	Ext. 3 Differentiation Time
20-94	PID Integral Time	21-64	Ext. 3 Dif. Gain Limit
20-95	PID Differentiation Time	22-0*	Appl. Functions
20-96	PID Diff. Gain Limit	22-0*	Miscellaneous
21-0*	Ext. CL Autotuning	22-00	External Interlock Delay
21-00	Closed Loop Type	22-2*	No-Flow Detection
21-01	PID Performance	22-20	Low Power Auto Set-up
21-02	PID Output Change	22-21	Low Power Detection
21-03	Minimum Feedback Level	22-22	Low Speed Detection
21-04	Maximum Feedback Level	22-23	No-Flow Function
21-09	PID Auto Tuning	22-24	No-Flow Delay
21-1*	Ext. CL 1 Ref./Fb.	22-26	Dry Pump Function
21-10	Ext. 1 Minimum Reference	22-27	Dry Pump Delay
21-11	Ext. 1 Maximum Reference	22-28	No-Flow Low Speed [RPM]
21-12	Ext. 1 Reference Source	22-29	No-Flow Low Speed [Hz]
21-13	Ext. 1 Feedback Source	22-3*	No-Flow Power Tuning
21-14	Ext. 1 Setpoint	22-30	No-Flow Power
21-15	Ext. 1 Reference [Unit]	22-31	Power Correction Factor
21-18	Ext. 1 Feedback [Unit]	22-32	Low Speed [RPM]
21-19	Ext. 1 Output [%]	22-33	Low Speed [Hz]
21-2*	Ext. CL 1 PID	22-34	Low Speed Power [kW]
21-20	Ext. 1 Normal/Inverse Control	22-35	Low Speed Power [HP]
21-21	Ext. 1 Proportional Gain	22-36	High Speed [RPM]
21-22	Ext. 1 Integral Time	22-37	High Speed [Hz]
21-23	Ext. 1 Differentiation Time	22-38	High Speed Power [kW]
21-24	Ext. 1 Dif. Gain Limit	22-39	High Speed Power [HP]
21-3*	Ext. CL 2 Ref./Fb.	22-4*	Sleep Mode
21-30	Ext. 2 Ref./Feedback Unit	22-40	Minimum Run Time
21-31	Ext. 2 Minimum Reference	22-41	Minimum Sleep Time
21-32	Ext. 2 Maximum Reference	22-42	Wake-up Speed [RPM]
21-33	Ext. 2 Reference Source	22-43	Wake-up Speed [Hz]
21-34	Ext. 2 Feedback Source	22-44	Wake-up Ref/FB Difference
21-35	Ext. 2 Setpoint	22-45	Setpoint Boost
21-37	Ext. 2 Reference [Unit]	22-46	Maximum Boost Time
21-38	Ext. 2 Feedback [Unit]	22-5*	End of Curve
21-39	Ext. 2 Output [%]	22-50	End of Curve Function
21-4*	Ext. CL 2 PID	22-51	End of Curve Delay
21-40	Ext. 2 Normal/Inverse Control	22-60	Broken Belt Function
21-41	Ext. 2 Proportional Gain	22-61	Broken Belt Torque
		22-62	Broken Belt Delay
		22-7*	Short Cycle Protection



25-25** Cascade Controller	26-16 Term. X42/1 Filter Time Constant	27-31 Stage On Speed [RPM]	29-22 Derag Power Factor
25-0* System Settings	26-17 Term. X42/1 Live Zero	27-32 Stage On Speed [Hz]	29-23 Derag Power Delay
25-00 Cascade Controller	26-2* Analog Input X42/3	27-33 Stage Off Speed [RPM]	29-24 Low Speed [RPM]
25-02 Motor Start	26-20 Terminal X42/3 Low Voltage	27-34 Stage Off Speed [Hz]	29-25 Low Speed [Hz]
25-04 Pump Cycling	26-21 Terminal X42/3 High Voltage	27-4* Staging Settings	29-26 Low Speed Power [kW]
25-05 Fixed Lead Pump	26-24 Term. X42/3 Low Ref./Feedb. Value	27-40 Auto Tune Staging Settings	29-27 Low Speed Power [HP]
25-06 Number of Pumps	26-25 Term. X42/3 High Ref./Feedb. Value	27-41 Ramp Down Delay	29-28 High Speed [RPM]
25-2* Bandwidth Settings	26-26 Term. X42/3 Filter Time Constant	27-42 Ramp Up Delay	29-29 High Speed [Hz]
25-20 Staging Bandwidth	26-27 Term. X42/3 Live Zero	27-43 Staging Threshold	29-30 High Speed Power [kW]
25-21 Override Bandwidth	26-3* Analog Input X42/5	27-44 Destaging Threshold	29-31 High Speed Power [HP]
25-22 Fixed Speed Bandwidth	26-30 Terminal X42/5 Low Voltage	27-45 Staging Speed [RPM]	29-32 Derag On Ref Bandwidth
25-23 SBW Staging Delay	26-31 Terminal X42/5 High Voltage	27-46 Staging Speed [Hz]	29-33 Power Derag Limit
25-24 SBW Destaging Delay	26-34 Term. X42/5 Low Ref./Feedb. Value	27-47 Destaging Speed [RPM]	30-3* Special Features
25-25 OBW Time	26-35 Term. X42/5 High Ref./Feedb. Value	27-48 Destaging Speed [Hz]	30-8* Compatibility (I)
25-26 Destage At No-Flow	26-36 Term. X42/5 Filter Time Constant	27-5* Alternate Settings	30-81 Brake Resistor (ohm)
25-27 Stage Function	26-37 Term. X42/5 Live Zero	27-50 Automatic Alternation	31-1* Bypass Option
25-28 Stage Function Time	26-4* Analog Out X42/7	27-51 Alternation Event	31-00 Bypass Mode
25-29 Destage Function	26-40 Terminal X42/7 Output	27-52 Alternation Time Interval	31-01 Bypass Start Time Delay
25-4* Staging Settings	26-41 Terminal X42/7 Min. Scale	27-53 Alternation Timer Value	31-02 Bypass Trip Time Delay
25-40 Ramp Down Delay	26-42 Terminal X42/7 Max. Scale	27-54 Alternation At Time of Day	31-03 Test Mode Activation
25-41 Ramp Up Delay	26-43 Terminal X42/7 Bus Control	27-55 Alternation Predefined Time	31-10 Bypass Status Word
25-42 Staging Threshold	26-44 Terminal X42/7 Timeout Preset	27-56 Alternate Capacity is <	31-11 Bypass Running Hours
25-43 Destaging Threshold	26-5* Analog Out X42/9	27-58 Run Next Pump Delay	31-19 Remote Bypass Activation
25-44 Staging Speed [RPM]	26-50 Terminal X42/9 Output	27-6* Digital Inputs	35-0* Sensor Input Option
25-45 Staging Speed [Hz]	26-51 Terminal X42/9 Min. Scale	27-60 Terminal X66/1 Digital Input	35-00 Term. X48/4 Temperature Unit
25-46 Destaging Speed [RPM]	26-52 Terminal X42/9 Max. Scale	27-61 Terminal X66/3 Digital Input	35-01 Term. X48/4 Input Type
25-47 Destaging Speed [Hz]	26-53 Terminal X42/9 Bus Control	27-62 Terminal X66/5 Digital Input	35-02 Term. X48/7 Temperature Unit
25-5* Alternation Settings	26-54 Terminal X42/9 Timeout Preset	27-63 Terminal X66/7 Digital Input	35-03 Term. X48/7 Input Type
25-50 Lead Pump Alternation	26-6* Analog Out X42/11	27-64 Terminal X66/9 Digital Input	35-04 Term. X48/10 Temperature Unit
25-51 Alternation Event	26-60 Terminal X42/11 Output	27-65 Terminal X66/11 Digital Input	35-05 Term. X48/10 Input Type
25-52 Alternation Time Interval	26-61 Terminal X42/11 Min. Scale	27-66 Terminal X66/13 Digital Input	35-06 Temperature Sensor Alarm Function
25-53 Alternation Timer Value	26-62 Terminal X42/11 Max. Scale	27-7* Connections	35-1* Temp. Input X48/4
25-54 Alternation Predefined Time	26-63 Terminal X42/11 Bus Control	27-70 Relay	35-14 Term. X48/4 Filter Time Constant
25-55 Alternate if Load < 50%	26-64 Terminal X42/11 Timeout Preset	27-9* Readouts	35-15 Term. X48/4 Temp. Monitor
25-56 Staging Mode at Alternation	27-2** Cascade CTL Option	27-91 Cascade Reference	35-16 Term. X48/4 Low Temp. Limit
25-58 Run Next Pump Delay	27-0* Control & Status	27-92 % Of Total Capacity	35-17 Term. X48/4 High Temp. Limit
25-59 Run on Mains Delay	27-01 Pump Status	27-93 Cascade Option Status	35-2* Temp. Input X48/7
25-8* Status	27-02 Manual Pump Control	27-94 Cascade System Status	35-24 Term. X48/7 Filter Time Constant
25-80 Cascade Status	27-03 Current Runtime Hours	27-95 Advanced Cascade Relay Output [bin]	35-25 Term. X48/7 Temp. Monitor
25-81 Pump Status	27-04 Pump Total Lifetime Hours	29-0** Water Application Functions	35-26 Term. X48/7 High Temp. Limit
25-83 Relay Status	27-1* Configuration	29-00 Pipe Fill	35-3* Temp. Input X48/10
25-84 Pump ON Time	27-10 Cascade Controller	29-01 Pipe Fill Speed [RPM]	35-34 Term. X48/10 Filter Time Constant
25-85 Relay ON Time	27-11 Number Of Drives	29-02 Pipe Fill Speed [Hz]	35-35 Term. X48/10 Temp. Monitor
25-86 Reset Relay Counters	27-12 Number Of Pumps	29-03 Pipe Fill Time	35-36 Term. X48/10 Low Temp. Limit
25-90 Pump Interlock	27-14 Pump Capacity	29-04 Pipe Fill Rate	35-4* Analog Input X48/2
25-91 Manual Alternation	27-16 Runtime Balancing	29-05 Filled Setpoint	35-42 Term. X48/2 Low Current
26-0** Analog I/O Option	27-17 Motor Starters	29-06 No-Flow Disable Timer	35-43 Term. X48/2 High Current
26-00 Terminal X42/1 Mode	27-18 Spin Time for Unused Pumps	29-1* Deragging Function	35-44 Term. X48/2 Low Ref./Feedb. Value
26-01 Terminal X42/3 Mode	27-19 Reset Current Runtime Hours	29-10 Derag Cycles	35-45 Term. X48/2 High Ref./Feedb. Value
26-02 Terminal X42/5 Mode	27-2* Bandwidth Settings	29-11 Derag at Start/Stop	35-46 Term. X48/2 Filter Time Constant
26-1* Analog Input X42/1	27-20 Normal Operating Range	29-12 Deragging Run Time	35-47 Term. X48/2 Live Zero
26-10 Terminal X42/1 Low Voltage	27-21 Override Limit	29-13 Derag Speed [RPM]	
26-11 Terminal X42/1 High Voltage	27-22 Fixed Speed Only Operating Range	29-14 Derag Speed [Hz]	
26-14 Term. X42/1 Low Ref./Feedb. Value	27-23 Staging Delay	29-15 Derag Off Delay	
26-15 Term. X42/1 High Ref./Feedb. Value	27-24 Destaging Delay	29-2* Derag Power Tuning	
	27-25 Override Hold Time	29-20 Derag Power [kW]	
	27-27 Min Speed Destage Delay	29-21 Derag Power [HP]	
	27-3* Staging Speed		
	27-30 Auto Tune Staging Speeds		

Index

A

Abbreviation.....	78
AC	
input.....	0
mains.....	0
waveform.....	0
AC input.....	17
AC mains.....	17
Additional resources.....	4
Alarm log.....	23
Alarms.....	38
AMA.....	36, 40, 43
Ambient conditions.....	65
Analog input.....	18, 39, 66
Analog output.....	18, 66
Analog signal.....	39
Analog speed reference.....	33
Approval.....	8
Auto on.....	24, 31, 36, 38
Automatic energy optimisation.....	29
Automatic motor adaptation.....	29
Auto-reset.....	22
Auxiliary equipment.....	21

B

Back plate.....	12
Braking.....	36, 41

C

Cable	
routing.....	21
Motor cable.....	13, 16, 63
Motor cable length.....	65
Specifications.....	65
Certification.....	8
Circuit breaker.....	21, 69, 70, 71
Clearance requirements.....	11
Closed loop.....	19
Communication option.....	42
Conduct.....	21
Control	
characteristic.....	68

Control card

Control card.....	39
Control card performance.....	68
Control card, 10 V DC output.....	68
Control card, 24 V DC output.....	67
Control card, RS485 serial communication.....	65
USB serial communication.....	68

Control signal.....	36
---------------------	----

Control terminal.....	24, 26, 36, 38
-----------------------	----------------

Control wiring.....	13, 15, 19, 21
---------------------	----------------

Convention.....	78
-----------------	----

Cooling.....	11, 63
--------------	--------

Cooling clearance.....	21
------------------------	----

Cos ϕ	64, 67
------------------	--------

Current

level.....	66
limit.....	47
mode.....	66
range.....	66
rating.....	40
DC current.....	0, 13
Input current.....	17
Output current.....	37

D

DC current.....	37
-----------------	----

DC link.....	39
--------------	----

Default setting.....	24
----------------------	----

Derating

Derating.....	65
---------------	----

Digital input.....	18, 19, 38, 40, 66
--------------------	--------------------

Digital output.....	67
---------------------	----

Dimensions.....	76, 77
-----------------	--------

Discharge time.....	9
---------------------	---

Disconnect switch.....	22
------------------------	----

Displacement power factor.....	64
--------------------------------	----

E

Efficiency.....	63, 65
-----------------	--------

Electrical interference.....	13
------------------------------	----

EMC.....	13
----------	----

EMC interference.....	15
-----------------------	----

Environment.....	65
------------------	----

Exploded view.....	6, 7
--------------------	------

External alarm reset.....	34
---------------------------	----

External command.....	0, 8, 38
-----------------------	----------

External controllers.....	4
---------------------------	---

External interlock.....	34
-------------------------	----

F	
Fault log.....	23
FC.....	20
Feedback.....	19, 21, 32, 37, 43, 45
Floating delta.....	17
Fuse.....	13, 42, 46, 69, 70, 71, 72, 73, 74, 75
Fuses.....	21
G	
Ground connection.....	21
Ground wire.....	13
Grounded delta.....	17
Grounding.....	16, 17, 21, 22
H	
Hand on.....	24, 36
Harmonics	
Harmonics.....	0 , 8
High altitude.....	65
High voltage.....	9, 22
Humidity.....	65
I	
IEC 61800-3.....	17
Initialisation.....	25
Input disconnect.....	17
Input power.....	0 , 13, 15, 17, 21, 22, 38, 46
Input power wiring.....	21
Input signal.....	19
Input terminal.....	17, 19, 22, 39
Input voltage.....	22
Installation	
Check list.....	21
environment.....	11
Installation.....	19, 20
Intended use.....	4
Interference isolation.....	21
Interlock.....	33
Isolated main.....	17
Items supplied.....	11
J	
Jumper.....	19
L	
Leakage current.....	10, 13
Lifting.....	12
Load sharing.....	9, 50, 51, 52, 53, 54, 55, 56, 57, 58, 59, 60, 61, 62, 63
Local control.....	22, 24, 36
Local control panel (LCP).....	22
M	
Main menu.....	23
Mains	
voltage.....	23, 36
Transient.....	8
Maintenance	
Maintenance.....	36
Manual initialisation.....	25
MCT 10.....	18, 22
Menu key.....	23
Menu structure.....	23
Modbus RTU.....	20
Motor	
current.....	0 , 8, 23, 29, 43
data.....	26, 29, 40, 44, 47
output.....	64
power.....	13, 23, 43
rotation.....	29
speed.....	25
status.....	4
thermistor.....	35
wiring.....	15, 21
Output current.....	40
Output performance (U, V, W).....	64
Thermistor.....	35
Motor thermal protection.....	35
Mounting.....	12, 21
Multiple frequency converters.....	13
N	
Nameplate.....	11
Navigation key.....	23, 25, 36
O	
Open loop.....	19
Operation key.....	23
Optional equipment.....	17, 19, 22
Output power wiring.....	21
Output terminal.....	22
Overcurrent protection.....	13
Overload	
High overload.....	63, 64
Normal overload.....	49, 53, 64
torque.....	64
Overvoltage.....	37, 47, 64, 67

P

Parameter Menu Structure.....	79
PELV.....	35, 65, 66, 67, 68
Phase loss.....	39
PM Motor.....	27
Potential equalisation.....	13
Potentiometer.....	33
Power connection.....	13
Power factor.....	0, 21, 64
Programming.....	19, 22, 23, 24, 39
Pulse input.....	67

Q

Qualified personnel.....	9
Quick menu.....	23

R

Ramp-down time.....	47
Ramp-up time.....	47
Reference.....	23, 36, 37
Reference	
Reference.....	32
Relay	
Relay.....	18
1.....	67
2.....	67
output.....	67
Remote commands.....	4
Remote reference.....	37
Reset.....	22, 23, 24, 25, 38, 40, 45
RFI filter.....	17
RMS current.....	0
RS485.....	35
RS485 serial communication.....	20
Run command.....	31
Run permissive.....	34, 37
Run/Stop command.....	33

S

Safe torque off.....	20
Safety.....	10
Screened cable.....	15, 21
Serial communication.....	18, 24, 36, 37, 38
Service.....	36
Setpoint.....	38
Set-up.....	31

Shock.....	11
Short circuit.....	41
Sleep mode.....	38
SmartStart.....	25
Specifications.....	20
Speed reference.....	19, 31, 33, 36
Start-up.....	25
Status display.....	36
Status mode.....	36
STO.....	20
Storage.....	11, 65
Supply voltage.....	17, 18, 22, 42
Switch.....	19
Switching frequency.....	37
Symbol.....	78
System feedback.....	4

T

Terminal 53.....	19
Terminal 54.....	19
Terminal tightening torques.....	68
Thermal protection.....	8
Thermistor.....	17, 40
Thermistor control wiring.....	17
Torque	
Starting torque.....	64
characteristic.....	64
limit.....	47
Transient protection.....	0
Trip	
Trip.....	35, 38
level.....	69, 70, 71
lock.....	38
Troubleshooting.....	48
True power factor.....	64

U

UL compliance.....	72
Unintended motor rotation.....	10
Unintended start.....	9, 36

V

Vibration.....	11
Voltage imbalance.....	39
Voltage level.....	66
VVC+.....	27

W

Warnings.....	38
Weight.....	76, 77
Windmilling.....	10
Wire size.....	13, 16
Wiring schematic.....	14



KSB Aktiengesellschaft
67225 Frankenthal • Johann-Klein-Str. 9 • 67227 Frankenthal (Deutschland)
Tel. +49 6233 86-0 • Fax +49 6233 86-3401
www.ksb.de

MG21H202

