



Operating Instructions

VLT[®] AutomationDrive FC 301/302

0.25-75 kW



Contents

1 Introduction	3
1.1 Purpose of the Manual	3
1.2 Additional Resources	3
1.3 Document and Software Version	3
1.4 Product Overview	3
1.5 Enclosure Types and Power Ratings	6
1.6 Approvals and Certifications	6
1.7 Disposal Instruction	6
2 Safety	7
2.1 Safety Symbols	7
2.2 Qualified Personnel	7
2.3 Safety Precautions	7
3 Mechanical Installation	9
3.1 Unpacking	9
3.2 Installation Environments	9
3.3 Mounting	10
4 Electrical Installation	11
4.1 Safety Instructions	11
4.2 EMC Compliant Installation	11
4.3 Grounding	11
4.4 Wiring Schematic	12
4.5 Access	14
4.6 Motor Connection	14
4.7 AC Mains Connection	15
4.8 Control Wiring	15
4.8.1 Control Terminal Types	16
4.8.2 Wiring to Control Terminals	17
4.8.3 Enabling Motor Operation (Terminal 27)	17
4.8.4 Voltage/Current Input Selection (Switches)	18
4.8.5 Safe Torque Off (STO)	18
4.8.6 Mechanical Brake Control	18
4.8.7 RS-485 Serial Communication	19
4.9 Installation Check List	20
5 Commissioning	21
5.1 Safety Instructions	21
5.2 Applying Power	21

5.3 Local Control Panel Operation	21
5.4 Basic Programming	24
5.4.1 Commissioning with SmartStart	24
5.4.2 Commissioning via [Main Menu]	24
5.4.3 Asynchronous Motor Setup	25
5.4.4 PM Motor Setup in VVC ^{plus}	25
5.4.5 Automatic Motor Adaptation (AMA)	26
5.5 Checking Motor Rotation	26
5.6 Checking Encoder Rotation	26
5.7 Local-control Test	27
5.8 System Start-up	27
6 Application Set-up Examples	28
7 Diagnostics and Troubleshooting	34
7.1 Maintenance and Service	34
7.2 Status Messages	34
7.3 Warning and Alarm Types	36
7.4 List of Warnings and Alarms	37
7.5 Troubleshooting	45
8 Specifications	47
8.1 Electrical Data	47
8.1.1 Mains Supply 3x200-240 V AC	47
8.1.2 Mains Supply 3x380-500 V AC	49
8.1.3 Mains Supply 3x525-600 V AC (FC 302 only)	52
8.1.4 Mains Supply 3x525-690 V AC (FC 302 only)	55
8.2 Mains Supply	57
8.3 Motor Output and Motor Data	57
8.4 Ambient Conditions	58
8.5 Cable Specifications	58
8.6 Control Input/Output and Control Data	58
8.7 Fuses and Circuit Breakers	62
8.8 Connection Tightening Torques	68
8.9 Power Ratings, Weight and Dimensions	69
9 Appendix	70
9.1 Symbols, Abbreviations and Conventions	70
9.2 Parameter Menu Structure	70
Index	75

1 Introduction

1.1 Purpose of the Manual

These operating instructions provide information for safe installation and commissioning of the frequency converter.

The operating instructions are intended for use by qualified personnel.

Read and follow the operating instructions to use the frequency converter safely and professionally, and pay particular attention to the safety instructions and general warnings. Keep these operating instructions available with the frequency converter at all times.

1.2 Additional Resources

Other resources are available to understand advanced frequency converter functions and programming.

- The *VLT® Programming Guide* provides greater detail on working with parameters and many application examples.
- The *VLT® Design Guide* provides detailed information about capabilities and functionality to design motor control systems.
- Instructions for operation with optional equipment.

Supplementary publications and manuals are available from Danfoss. See www.danfoss.com/BusinessAreas/DrivesSolutions/Documentations/VLT+Technical+Documentation.htm for listings.

Disclosure, duplication and sale of this document, as well as communication of its content, are prohibited unless explicitly permitted. Infringement of this prohibition incurs liability for damages. All rights reserved with regard to patents, utility patents and registered designs. VLT® is a registered trademark.

1.3 Document and Software Version

This manual is regularly reviewed and updated. All suggestions for improvement are welcome. *Table 1.1* shows the document version and the corresponding software version.

Edition	Remarks	Software version
MG33ANxx	Replaces MG33AMxx	6.72

Table 1.1 Document and Software Version

1.4 Product Overview

1.4.1 Intended Use

The frequency converter is an electronic motor controller intended for

- regulation of motor speed in response to system feedback or to remote commands from external controllers. A power drive system consists of the frequency converter, the motor and equipment driven by the motor.
- system and motor status surveillance.

The frequency converter can also be used for motor protection.

Depending on configuration, the frequency converter can be used in standalone applications or form part of a larger appliance or installation.

The frequency converter is allowed for use in residential, industrial and commercial environments in accordance with local laws and standards.

NOTICE

In a residential environment this product can cause radio interference, in which case supplementary mitigation measures can be required.

Foreseeable misuse

Do not use the frequency converter in applications which are non-compliant with specified operating conditions and environments. Ensure compliance with the conditions specified in *8 Specifications*.

1.4.2 Exploded Views

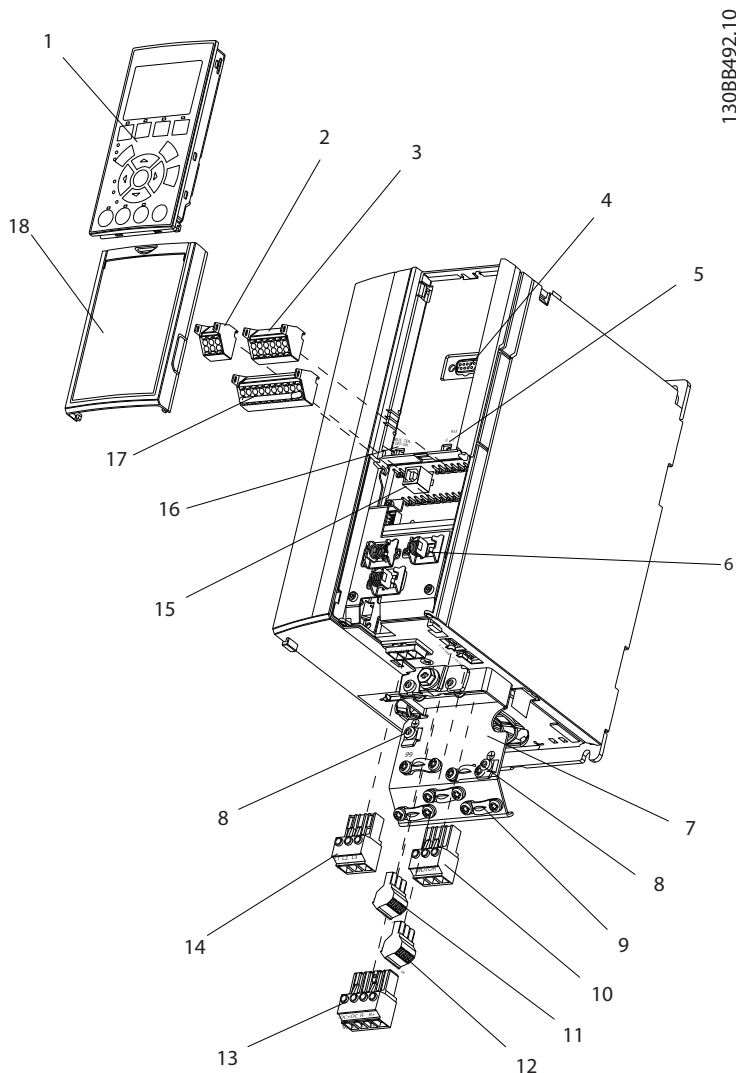
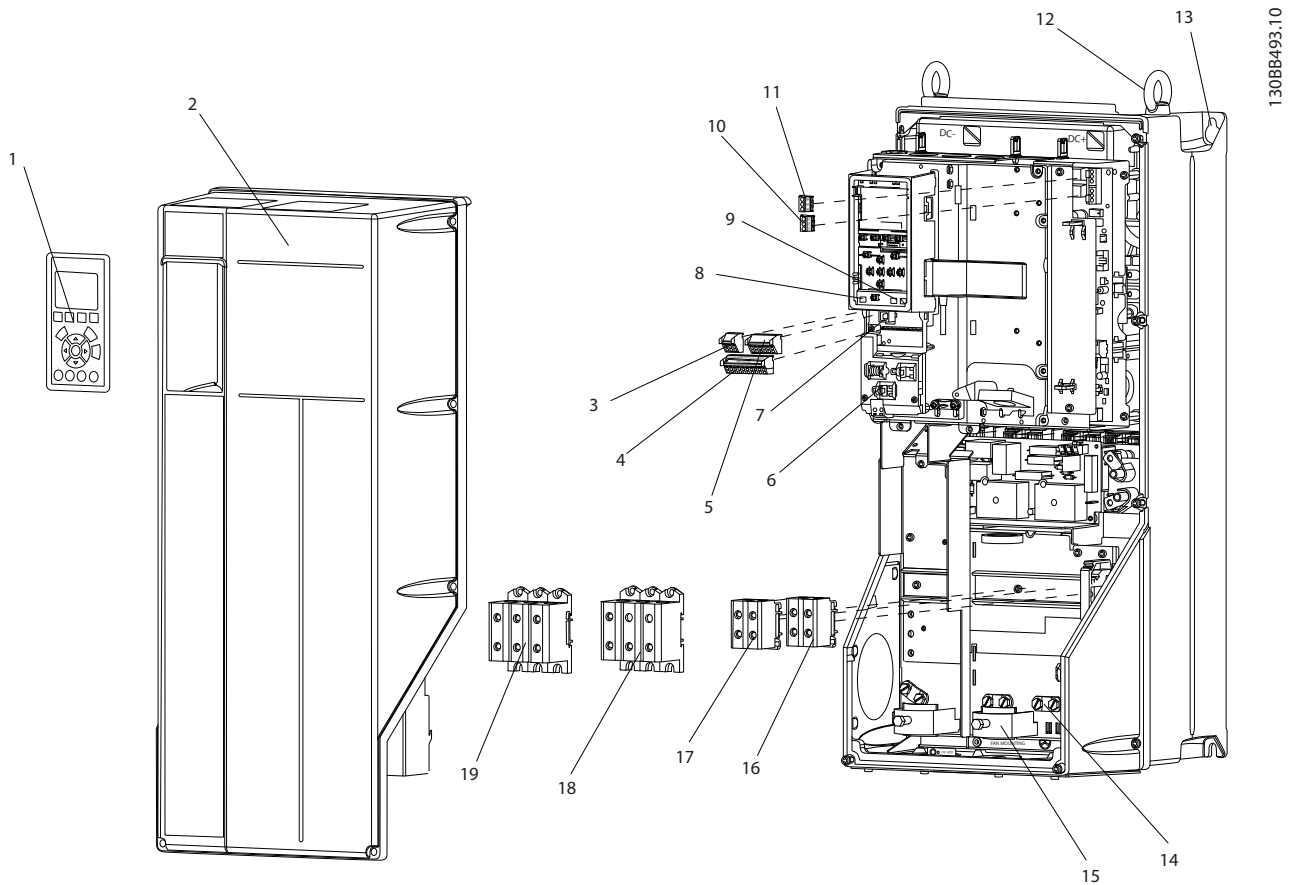

Illustration 1.1 Exploded View Enclosure Type A, IP20

1	Local control panel (LCP)	10	Motor output terminals 96 (U), 97 (V), 98 (W)
2	RS-485 serial bus connector (+68, -69)	11	Relay 2 (01, 02, 03)
3	Analog I/O connector	12	Relay 1 (04, 05, 06)
4	LCP input plug	13	Brake (-81, +82) and load sharing (-88, +89) terminals
5	Analog switches (A53), (A54)	14	Mains input terminals 91 (L1), 92 (L2), 93 (L3)
6	Cable screen connector	15	USB connector
7	Decoupling plate	16	Serial bus terminal switch
8	Grounding clamp (PE)	17	Digital I/O and 24 V power supply
9	Screened cable grounding clamp and strain relief	18	Cover

Table 1.2 Legend to *Illustration 1.1*



1308B493:10

Illustration 1.2 Exploded View Enclosure Types B and C, IP55 and IP66

1	Local control panel (LCP)	11	Relay 2 (04, 05, 06)
2	Cover	12	Lifting ring
3	RS-485 serial bus connector	13	Mounting slot
4	Digital I/O and 24 V power supply	14	Grounding clamp (PE)
5	Analog I/O connector	15	Cable screen connector
6	Cable screen connector	16	Brake terminal (-81, +82)
7	USB connector	17	Load sharing terminal (DC bus) (-88, +89)
8	Serial bus terminal switch	18	Motor output terminals 96 (U), 97 (V), 98 (W)
9	Analog switches (A53), (A54)	19	Mains input terminals 91 (L1), 92 (L2), 93 (L3)
10	Relay 1 (01, 02, 03)		

Table 1.3 Legend to Illustration 1.2

1.4.3 Block Diagram of the Frequency Converter

Illustration 1.3 is a block diagram of the frequency converter's internal components. See Table 1.4 for their functions.

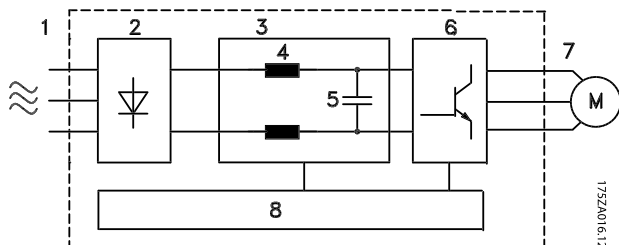

Illustration 1.3 Frequency Converter Block Diagram

Area	Title	Functions
1	Mains input	<ul style="list-style-type: none"> 3-phase AC mains power supply to the frequency converter
2	Rectifier	<ul style="list-style-type: none"> The rectifier bridge converts the AC input to DC current to supply inverter power
3	DC bus	<ul style="list-style-type: none"> Intermediate DC-bus circuit handles the DC current
4	DC reactors	<ul style="list-style-type: none"> Filter the intermediate DC circuit voltage Prevent line transient protection Reduce RMS current Raise the power factor reflected back to the line Reduce harmonics on the AC input
5	Capacitor bank	<ul style="list-style-type: none"> Stores the DC power Provides ride-through protection for short power losses
6	Inverter	<ul style="list-style-type: none"> Converts the DC into a controlled PWM AC waveform for a controlled variable output to the motor
7	Output to motor	<ul style="list-style-type: none"> Regulated 3-phase output power to the motor

Area	Title	Functions
8	Control circuitry	<ul style="list-style-type: none"> Input power, internal processing, output, and motor current are monitored to provide efficient operation and control User interface and external commands are monitored and performed Status output and control can be provided

Table 1.4 Legend to Illustration 1.3

1.5 Enclosure Types and Power Ratings

For enclosure types and power ratings of the frequency converters, refer to 8.9 Power Ratings, Weight and Dimensions.

1.6 Approvals and Certifications



Table 1.5 Approvals and Certifications

More approvals and certifications are available. Contact local Danfoss partner. The T7 (525-690 V) frequency converters are not certified for UL.

The frequency converter complies with UL508C thermal memory retention requirements. For more information, refer to the section *Motor Thermal Protection* in the *Design Guide*.

For compliance with the European Agreement concerning International Carriage of Dangerous Goods by Inland Waterways (ADN), refer to *ADN-compliant Installation* in the *Design Guide*.

1.7 Disposal Instruction

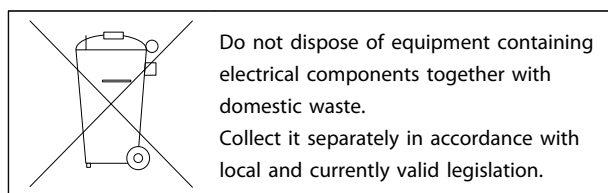

Table 1.6 Disposal Instruction

2 Safety

2.1 Safety Symbols

The following symbols are used in this document.

⚠ WARNING

Indicates a potentially hazardous situation which could result in death or serious injury.

⚠ CAUTION

Indicates a potentially hazardous situation which could result in minor or moderate injury. It may also be used to alert against unsafe practices.

NOTICE

Indicates important information, including situations that may result in damage to equipment or property.

2.2 Qualified Personnel

Correct and reliable transport, storage, installation, operation and maintenance are required for the trouble-free and safe operation of the frequency converter. Only qualified personnel is allowed to install or operate this equipment.

Qualified personnel is defined as trained staff, who are authorised to install, commission, and maintain equipment, systems and circuits in accordance with pertinent laws and regulations. Additionally, the personnel must be familiar with the instructions and safety measures described in this document.

2.3 Safety Precautions

⚠ WARNING

HIGH VOLTAGE!

Frequency converters contain high voltage when connected to AC mains input power. Installation, start-up, and maintenance must be performed by qualified personnel only. Failure to perform installation, start-up, and maintenance by qualified personnel could result in death or serious injury.

⚠ WARNING

UNINTENDED START!

When the frequency converter is connected to AC mains, the motor may start at any time. The frequency converter, motor, and any driven equipment must be in operational readiness. Failure to be in operational readiness when the frequency converter is connected to AC mains could result in death, serious injury, equipment or property damage.

⚠ WARNING

DISCHARGE TIME!

Frequency converters contain DC-link capacitors that can remain charged even when the frequency converter is not powered. To avoid electrical hazards, disconnect AC mains, any permanent magnet type motors, and any remote DC-link power supplies, including battery backups, UPS and DC-link connections to other frequency converters. Wait for the capacitors to discharge completely before performing any service or repair work. The amount of waiting time is listed in *Table 2.1*. Failure to wait the specified time after power has been removed before doing service or repair could result in death or serious injury.

Voltage [V]	Minimum waiting time [minutes]		
	4	7	15
200-240	0.25-3.7 kW		5.5-37 kW
380-500	0.25-7.5 kW		11-75 kW
525-600	0.75-7.5 kW		11-75 kW
525-690		1.5-7.5 kW	11-75 kW
High voltage may be present even when the warning LED indicator lights are off.			

Table 2.1 Discharge Time

⚠ WARNING

LEAKAGE CURRENT HAZARD!

Leakage currents are higher than 3.5 mA. It is the responsibility of the user or certified electrical installer to ensure correct grounding of the equipment. Failure to ground the frequency converter properly could result in death or serious injury.

2**⚠ WARNING****EQUIPMENT HAZARD!**

Rotating shafts and electrical equipment can be hazardous. All electrical work must conform to national and local electrical codes. Installation, start-up, and maintenance are performed only by trained and qualified personnel. Failure to follow these guidelines could result in death or serious injury.

⚠ WARNING**WINDMILLING!**

Unintended rotation of permanent magnet motors causes a risk of personal injury and equipment damage. Ensure permanent magnet motors are blocked to prevent unintended rotation.

⚠ CAUTION**POTENTIAL HAZARD IN THE EVENT OF INTERNAL FAILURE!**

Risk of personal injury when the frequency converter is not properly closed. Before applying power, ensure all safety covers are in place and securely fastened.

3 Mechanical Installation

3.1 Unpacking

3.1.1 Items Supplied

Items supplied may vary according to product configuration.

- Make sure the items supplied and the information on the nameplate correspond to the order confirmation.
- Check the packaging and the frequency converter visually for damage caused by inappropriate handling during shipment. File any claim for damage with the carrier. Retain damaged parts for clarification.

NOTICE

Do not remove the nameplate from the frequency converter (loss of warranty).

3.1.2 Storage

Ensure that requirements for storage are fulfilled. Refer to 8.4 *Ambient Conditions* for further details.

3.2 Installation Environments

NOTICE

In environments with airborne liquids, particles, or corrosive gases, ensure that the IP/Type rating of the equipment matches the installation environment. Failure to meet requirements for ambient conditions can reduce lifetime of the frequency converter. Ensure that requirements for air humidity, temperature and altitude are met.

Vibration and Shock

The frequency converter complies with requirements for units mounted on the walls and floors of production premises, as well as in panels bolted to walls or floors.

For detailed ambient conditions specifications, refer to 8.4 *Ambient Conditions*.

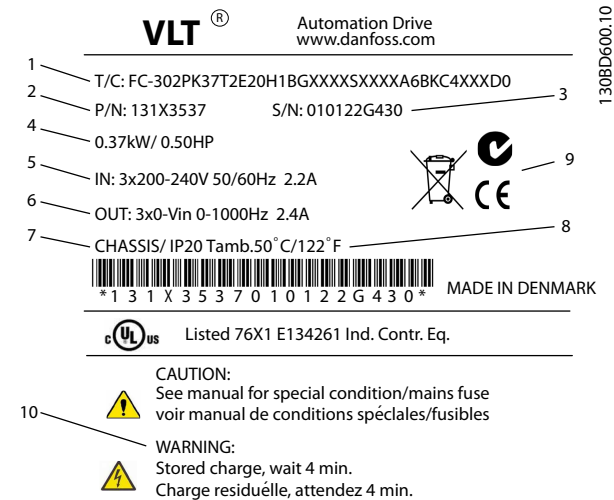

Illustration 3.1 Product Nameplate (Example)

1	Type code
2	Order number
3	Serial number
4	Power rating
5	Input voltage, frequency and current (at low/high voltages)
6	Output voltage, frequency and current (at low/high voltages)
7	Enclosure type and IP rating
8	Maximum ambient temperature
9	Certifications
10	Discharge time (Warning)

Table 3.1 Legend to Illustration 3.1

3.3 Mounting

NOTICE

Improper mounting can result in overheating and reduced performance.

Cooling

- Ensure that top and bottom clearance for air cooling is provided. See *Illustration 3.2* for clearance requirements.

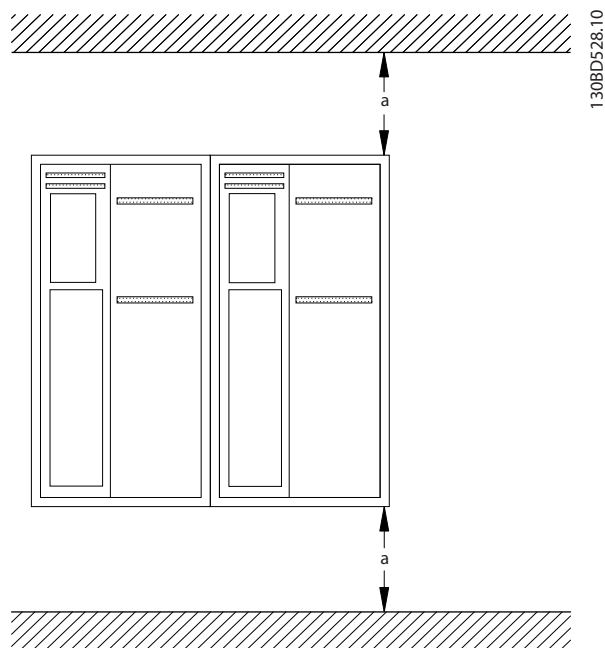

Illustration 3.2 Top and Bottom Cooling Clearance

Enclosure	A1-A5	B1-B4	C1, C3	C2, C4
a [mm]	100	200	200	225

Table 3.2 Minimum Airflow Clearance Requirements

Lifting

- To determine a safe lifting method, check the weight of the unit, see *8.9 Power Ratings, Weight and Dimensions*.
- Ensure that the lifting device is suitable for the task.
- If necessary, plan for a hoist, crane, or forklift with the appropriate rating to move the unit.
- For lifting, use hoist rings on the unit, when provided.

Mounting

1. Ensure that the strength of the mounting location supports the unit weight. The frequency converter allows side-by-side installation.
2. Locate the unit as near to the motor as possible. Keep the motor cables as short as possible.
3. Mount the unit vertically on a solid flat surface or on the optional back plate.
4. Use the slotted mounting holes on the unit for wall mounting, when provided.

Mounting with back plate and railings

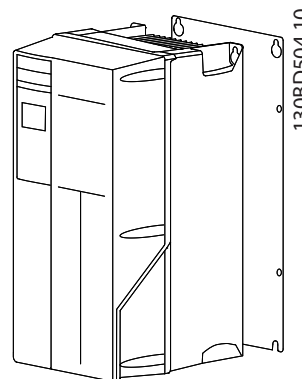

Illustration 3.3 Proper Mounting with Back Plate

NOTICE

Back plate is required when mounted on railings.

4 Electrical Installation

4.1 Safety Instructions

See 2 *Safety* for general safety instructions.

⚠ WARNING

INDUCED VOLTAGE!

Induced voltage from output motor cables that run together can charge equipment capacitors even with the equipment turned off and locked out. Failure to run output motor cables separately or use screened cables could result in death or serious injury.

⚠ CAUTION

DC CURRENT HAZARD!

A DC current in the protective grounding conductor can be caused by the frequency converters. When a residual current-operated protective or monitoring device (RCD/RCM) is used for protection, only an RCD or RCM of Type B is allowed.

Over-current Protection

- Additional protective equipment such as short-circuit protection or motor thermal protection between frequency converter and motor is required for applications with multiple motors.
- Input fusing is required to provide short-circuit and over-current protection. If not factory-supplied, fuses must be provided by the installer. See maximum fuse ratings in 8.7 *Fuses and Circuit Breakers*.

Wire Type and Ratings

- All wiring must comply with local and national regulations regarding cross-section and ambient temperature requirements.
- Power connection wire recommendation: minimum 75 °C rated copper wire.

See 8.1 *Electrical Data* and 8.5 *Cable Specifications* for recommended wire sizes and types.

4.2 EMC Compliant Installation

To obtain an EMC compliant installation, follow the instructions provided in 4.3 *Grounding*, 4.4 *Wiring Schematic*, 4.6 *Motor Connection*, and 4.8 *Control Wiring*.

4.3 Grounding

⚠ WARNING

LEAKAGE CURRENT HAZARD!

Leakage currents are higher than 3.5 mA. It is the responsibility of the user or certified electrical installer to ensure correct grounding of the equipment. Failure to ground the frequency converter properly could result in death or serious injury.

For electrical safety

- Ground the frequency converter properly in accordance with applicable standards and directives.
- Use a dedicated ground wire for input power, motor power and control wiring.
- Do not ground one frequency converter to another in a “daisy chain” fashion.
- Keep the ground wire connections as short as possible.
- Follow motor manufacturer wiring requirements.
- Minimum cable cross-section: 10 mm² (or 2 rated ground wires terminated separately).

For EMC compliant installation

- Establish electrical contact between cable screen and frequency converter enclosure by using metal cable glands or by using the clamps provided on the equipment (see *Illustration 4.5* and *Illustration 4.6*).
- Use high-strand wire to reduce electrical interference.
- Do not use pigtailed.

NOTICE

POTENTIAL EQUALISATION!

Electrical interference risks disturbing the entire installation, when the ground potential between the frequency converter and the system is different. To avoid electrical interference, install equalising cables between the system components. Recommended cable cross-section: 16 mm².

4.4 Wiring Schematic

4

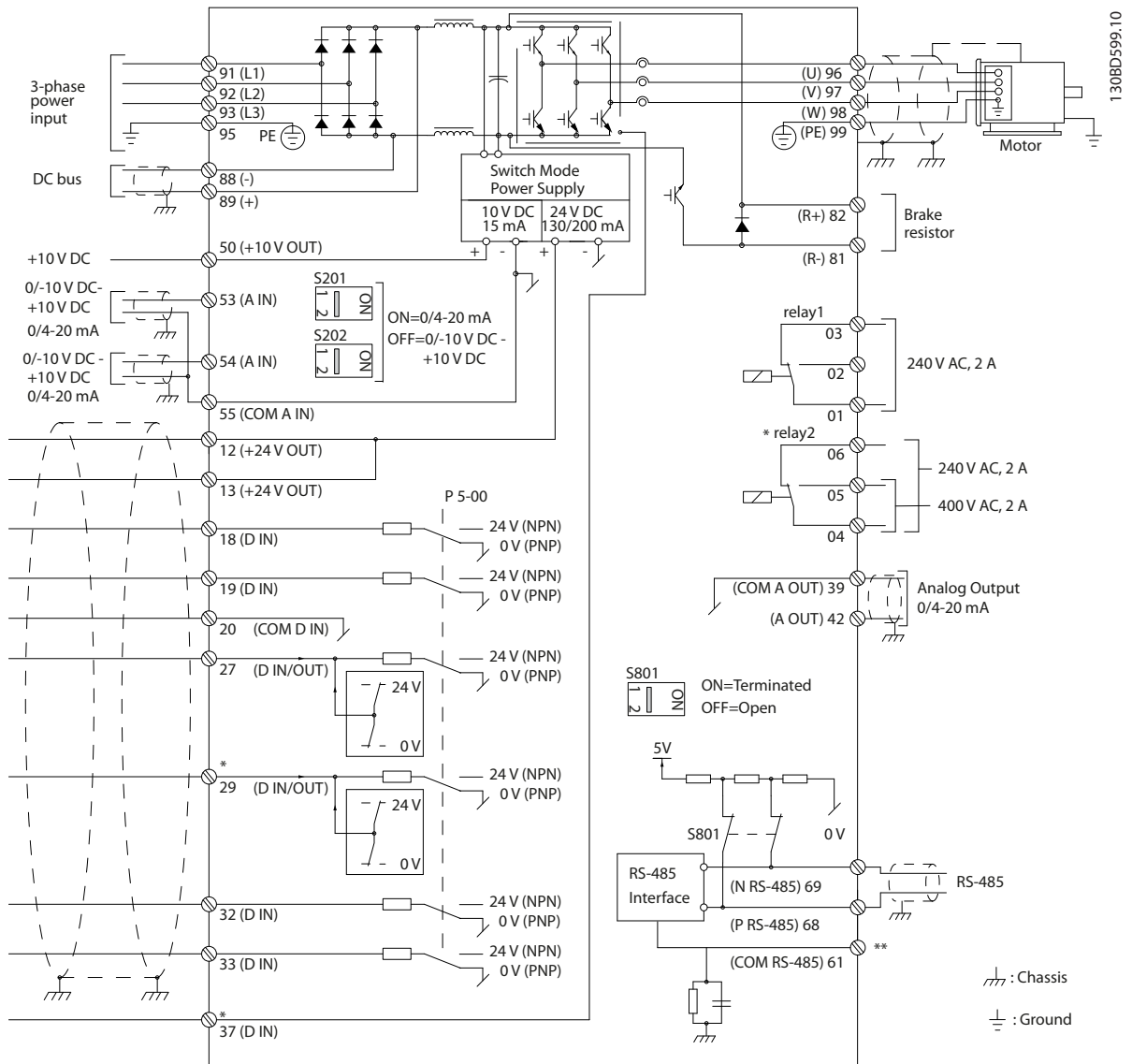

Illustration 4.1 Basic Wiring Schematic

A=Analog, D=Digital

*Terminal 37 (optional) is used for Safe Torque Off. For Safe Torque Off installation instructions, refer to the *Safe Torque Off Operating Instructions for Danfoss VLT® Frequency Converters*. Terminal 37 is not included in FC 301 (except enclosure type A1). Relay 2 and terminal 29 have no function in FC 301.

**Do not connect cable screen.

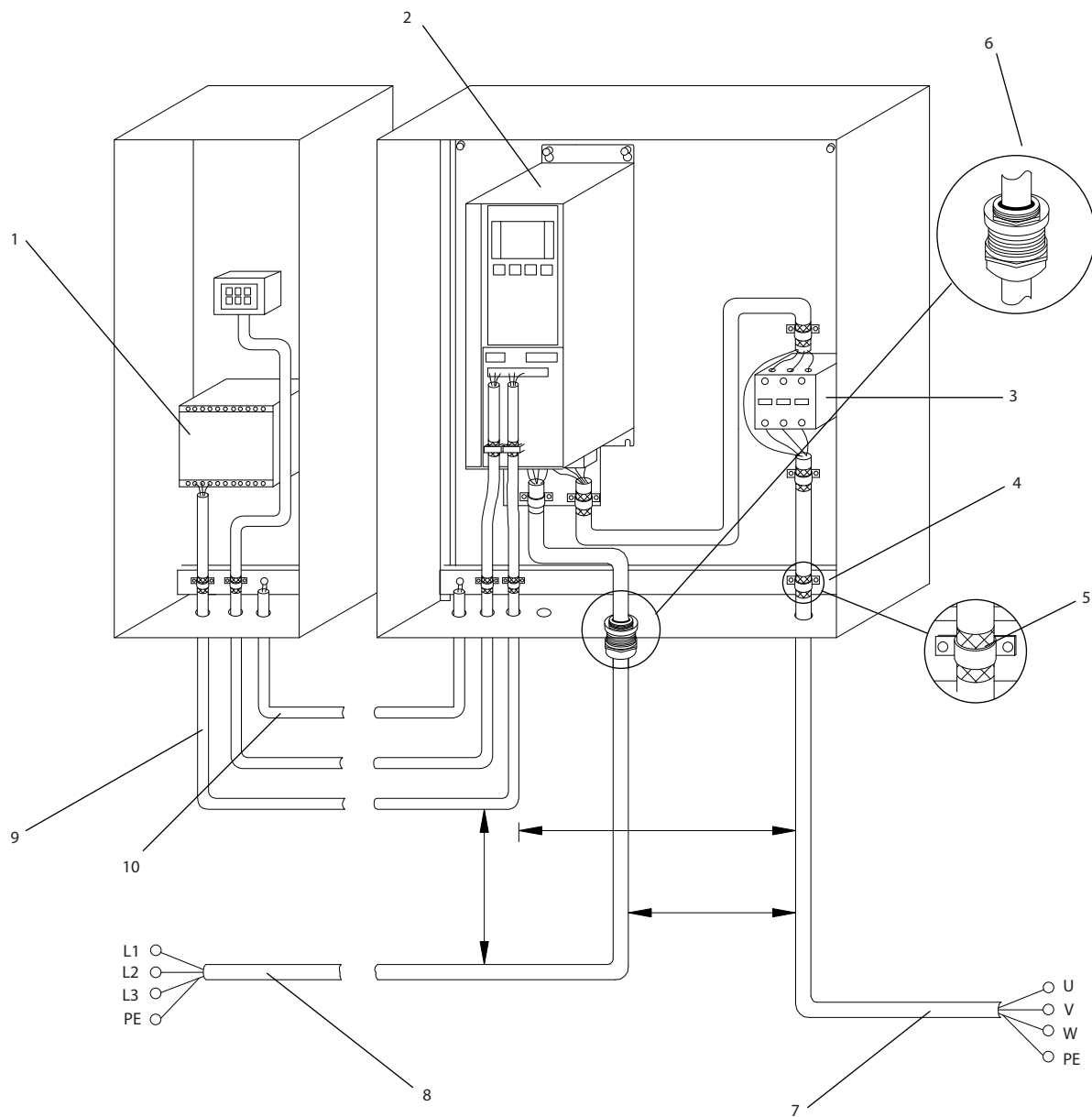

Illustration 4.2 EMC-correct Electrical Connection

1	PLC	6	Cable gland
2	Frequency converter	7	Motor, 3-phase and PE (screened)
3	Output contactor	8	Mains, 3-phase and reinforced PE (not screened)
4	Cable clamp	9	Control wiring (screened)
5	Cable insulation (stripped)	10	Potential equalisation min. 16 mm ² (0.025 in)

Table 4.1 Legend to Illustration 4.2

NOTICE

EMC INTERFERENCE!

Use screened cables for motor and control wiring, and separate cables for input power, motor wiring and control wiring. Failure to isolate power, motor and control cables can result in unintended behaviour or reduced performance. Minimum 200 mm (7.9 in) clearance between power, motor and control cables.

4.5 Access

- Remove cover with a screw driver (See *Illustration 4.3*) or by loosening attaching screws (See *Illustration 4.4*).

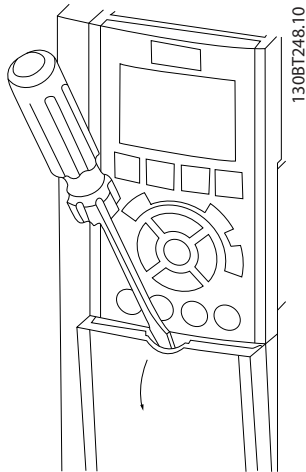

Illustration 4.3 Access to Wiring for IP20 and IP21 Enclosures

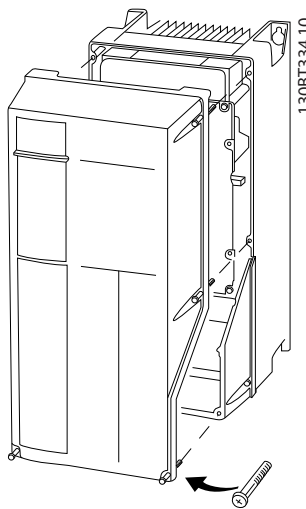

Illustration 4.4 Access to Wiring for IP55 and IP66 Enclosures

See *Table 4.2* before tightening covers.

Enclosure	IP55	IP66
A4/A5	2	2
B1/B2	2.2	2.2
C1/C2	2.2	2.2
No screws to tighten for A1/A2/A3/B3/B4/C3/C4.		

Table 4.2 Tightening Torques for Covers [Nm]

4.6 Motor Connection

WARNING

INDUCED VOLTAGE!

Induced voltage from output motor cables that run together can charge equipment capacitors even with the equipment turned off and locked out. Failure to run output motor cables separately or use screened cables could result in death or serious injury.

- Comply with local and national electrical codes for cable sizes. For maximum wire sizes see *8.1 Electrical Data*.
- Follow motor manufacturer wiring requirements.
- Motor wiring knockouts or access panels are provided at the base of IP21 (NEMA1/12) and higher units.
- Do not wire a starting or pole-changing device (e.g. Dahlander motor or slip ring induction motor) between the frequency converter and the motor.

Procedure

- Strip a section of the outer cable insulation.
- Position the stripped wire under the cable clamp to establish mechanical fixation and electrical contact between cable screen and ground.
- Connect ground wire to the nearest grounding terminal in accordance with grounding instructions provided in *4.3 Grounding*, see *Illustration 4.5*.
- Connect the 3-phase motor wiring to terminals 96 (U), 97 (V), and 98 (W), see *Illustration 4.5*.
- Tighten terminals in accordance with the information provided in *8.8 Connection Tightening Torques*.

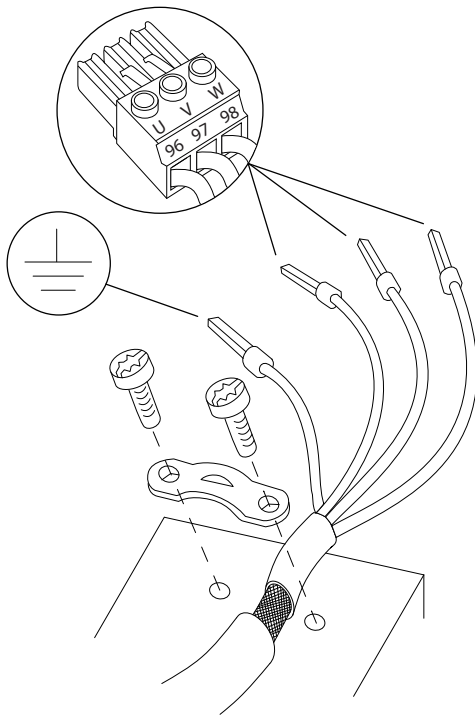

1308D531.10

Illustration 4.5 Motor Connection

Illustration 4.6 represents mains input, motor, and earth grounding for basic frequency converters. Actual configurations vary with unit types and optional equipment.

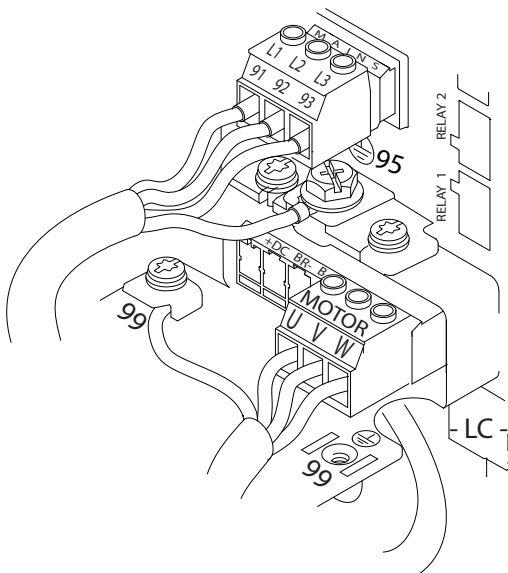

1308B920.10

Illustration 4.6 Example of Motor, Mains and Ground Wiring

4.7 AC Mains Connection

- Size wiring based upon the input current of the frequency converter. For maximum wire sizes see 8.1 *Electrical Data*.
- Comply with local and national electrical codes for cable sizes.

Procedure

1. Connect 3-phase AC input power wiring to terminals L1, L2, and L3 (see *Illustration 4.6*).
2. Depending on the configuration of the equipment, input power is connected to the mains input terminals or the input disconnect.
3. Ground the cable in accordance with grounding instructions provided in 4.3 *Grounding*.
4. When supplied from an isolated mains source (IT mains or floating delta) or TT/TN-S mains with a grounded leg (grounded delta), ensure that 14-50 RFI Filter is set to OFF to avoid damage to the intermediate circuit and to reduce earth capacity currents in accordance with IEC 61800-3.

4.8 Control Wiring

- Isolate control wiring from high power components in the frequency converter.
- When the frequency converter is connected to a thermistor, ensure that the thermistor control wiring is screened and reinforced/double insulated. A 24 V DC supply voltage is recommended.

4.8.1 Control Terminal Types

Illustration 4.7 and Illustration 4.8 show the removable frequency converter connectors. Terminal functions and default settings are summarised in Table 4.3 and Table 4.4.

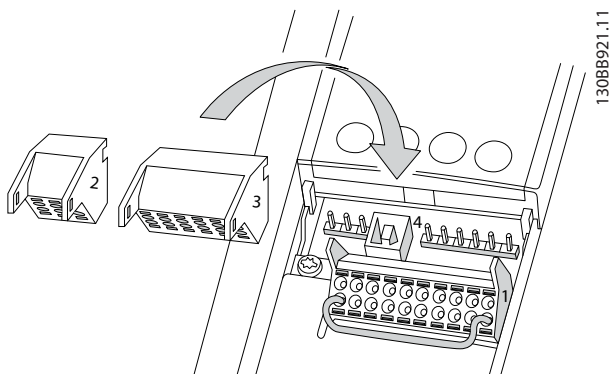

Illustration 4.7 Control Terminal Locations

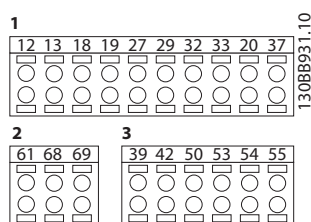

Illustration 4.8 Terminal Numbers

- Connector 1** provides 4 programmable digital inputs terminals, 2 additional digital terminals programmable as either input or output, a 24 V DC terminal supply voltage, and a common for optional customer supplied 24 V DC voltage. FC 302 and FC 301 (optional in A1 enclosure) also provide a digital input for STO (Safe Torque Off) function.
- Connector 2** terminals (+)68 and (-)69 for RS-485 serial communication connection
- Connector 3** provides 2 analog inputs, one analog output, 10 V DC supply voltage, and commons for the inputs and output
- Connector 4** is a USB port available for use with the MCT 10 Set-up Software

Terminal description			
Terminal	Parameter	Default setting	Description
Digital inputs/outputs			
12, 13	-	+24 V DC	24 V DC supply voltage for digital inputs and external transducers. Maximum output current 200 mA (130 mA for FC 301) for all 24 V loads.
18	5-10	[8] Start	Digital inputs.
19	5-11	[10] Reversing	
32	5-14	[0] No operation	
33	5-15	[0] No operation	
27	5-12	[2] Coast inverse	For digital input or output. Default setting is input.
29	5-13	[14] JOG	
20	-		Common for digital inputs and 0 V potential for 24 V supply.
37	-	Safe Torque Off (STO)	Safe input. Used for STO.
Analog inputs/outputs			
39	-		Common for analog output
42	6-50	[0] No operation	Programmable analog output. 0-20 mA or 4-20 mA at a maximum of 500 Ω
50	-	+10 V DC	10 V DC analog supply voltage for potentiometer or thermistor. 15 mA maximum
53	6-1*	Reference	Analog input. For voltage or current. Switches A53 and A54 select mA or V.
54	6-2*	Feedback	
55	-		Common for analog input

Table 4.3 Terminal Description Digital Inputs/Outputs, Analog Inputs/Outputs

Terminal description			
Terminal	Parameter	Default setting	Description
Serial communication			
61	-		Integrated RC-Filter for cable screen. ONLY for connecting the screen in the event of EMC problems.
68 (+)	8-3*		RS-485 Interface. A control card switch is provided for termination resistance.
69 (-)	8-3*		
Relays			
01, 02, 03	5-40 [0]	[0] No operation	Form C relay output. For AC or DC voltage and resistive or inductive loads.
04, 05, 06	5-40 [1]	[0] No operation	

Table 4.4 Terminal Description Serial Communication

Additional terminals:

- 2 form C relay outputs. Location of the outputs depends on frequency converter configuration.
- Terminals located on built-in optional equipment. See the manual provided with the equipment option.

4.8.2 Wiring to Control Terminals

Control terminal connectors can be unplugged from the frequency converter for ease of installation, as shown in *Illustration 4.7*.

NOTICE

Keep control wires as short as possible and separate from high power cables to minimise interference.

1. Open the contact by inserting a small screw driver into the slot above the contact and push the screw driver slightly upwards.

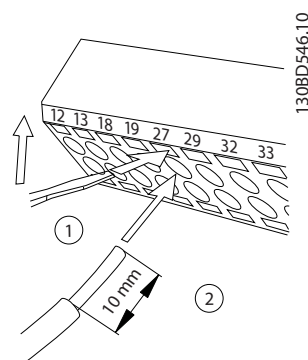

Illustration 4.9 Connecting Control Wires

2. Insert the bared control wire into the contact.
3. Remove the screw driver to fasten the control wire into the contact.
4. Ensure the contact is firmly established and not loose. Loose control wiring can be the source of equipment faults or less than optimal operation.

See 8.5 *Cable Specifications* for control terminal wiring sizes and 6 *Application Set-up Examples* for typical control wiring connections.

4.8.3 Enabling Motor Operation (Terminal 27)

A jumper wire may be required between terminal 12 (or 13) and terminal 27 for the frequency converter to operate when using factory default programming values.

- Digital input terminal 27 is designed to receive an 24 V DC external interlock command. In many applications, the user wires an external interlock device to terminal 27.
- When no interlock device is used, wire a jumper between control terminal 12 (recommended) or 13 to terminal 27. This provides an internal 24 V signal on terminal 27.
- When the status line at the bottom of the LCP reads AUTO REMOTE COAST, this indicates that the unit is ready to operate but is missing an input signal on terminal 27.
- When factory installed optional equipment is wired to terminal 27, do not remove that wiring.

NOTICE

The frequency converter cannot operate without a signal on terminal 27 unless terminal 27 is re-programmed.

4.8.4 Voltage/Current Input Selection (Switches)

The analog input terminals 53 and 54 allow setting of input signal to voltage (0-10 V) or current (0/4-20 mA).

Default parameter settings:

- Terminal 53: speed reference signal in open loop (see 16-61 Terminal 53 Switch Setting).
- Terminal 54: feedback signal in closed loop (see 16-63 Terminal 54 Switch Setting).

NOTICE

Disconnect power to the frequency converter before changing switch positions.

1. Remove the local control panel (see Illustration 4.10).
2. Remove any optional equipment covering the switches.
3. Set switches A53 and A54 to select the signal type. U selects voltage, I selects current.

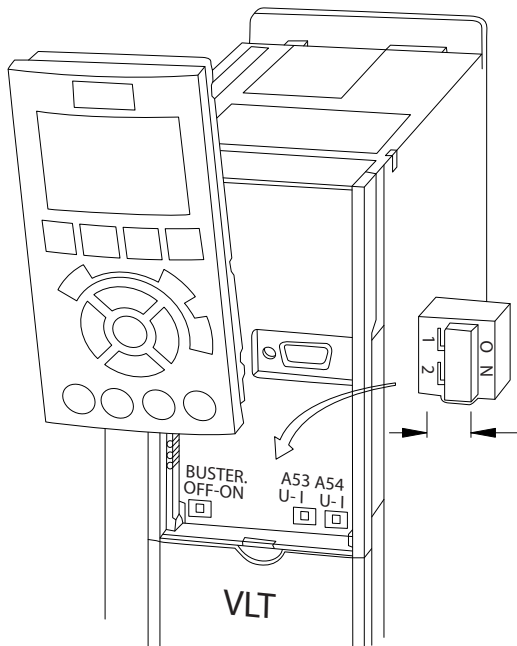

Illustration 4.10 Location of Terminals 53 and 54 Switches

4.8.5 Safe Torque Off (STO)

To run Safe Torque Off, additional wiring for the frequency converter is required, refer to *Safe Torque Off Operating Instructions for Danfoss VLT® Frequency Converters* for further information.

4.8.6 Mechanical Brake Control

In hoisting/lowering applications, it is necessary to control an electro-mechanical brake:

- Control the brake using any relay output or digital output (terminal 27 or 29).
- Keep the output closed (voltage-free) as long as the frequency converter is unable to keep the motor at standstill, for example due to the load being too heavy.
- Select [32] Mechanical brake control in parameter group 5-4* Relays for applications with an electro-mechanical brake.
- The brake is released when the motor current exceeds the preset value in 2-20 Release Brake Current.
- The brake is engaged when the output frequency is less than the frequency set in 2-21 Activate Brake Speed [RPM] or 2-22 Activate Brake Speed [Hz], and only if the frequency converter carries out a stop command.

If the frequency converter is in alarm mode or in an over-voltage situation, the mechanical brake immediately closes.

The frequency converter is not a safety device. It is the responsibility of the system designer to integrate safety devices according to relevant national crane/lift regulations.

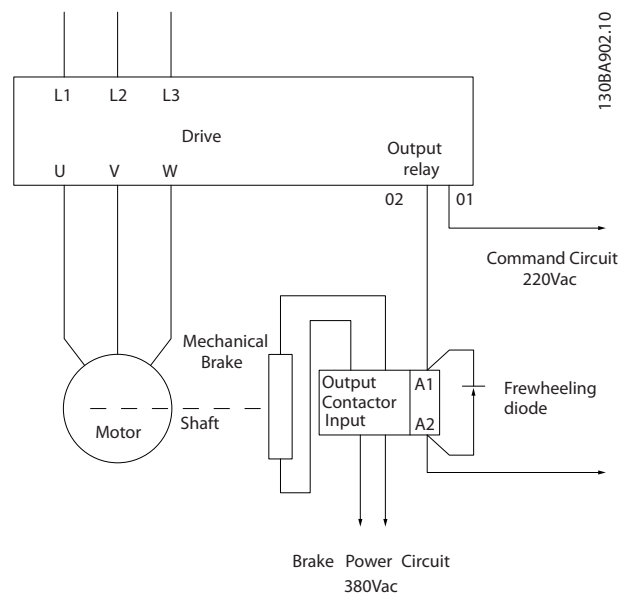

Illustration 4.11 Connecting the Mechanical Brake to the Frequency Converter

4.8.7 RS-485 Serial Communication

Connect RS-485 serial communication wiring to terminals (+)68 and (-)69.

- Use screened serial communication cable (recommended)
- See 4.3 *Grounding* for proper grounding

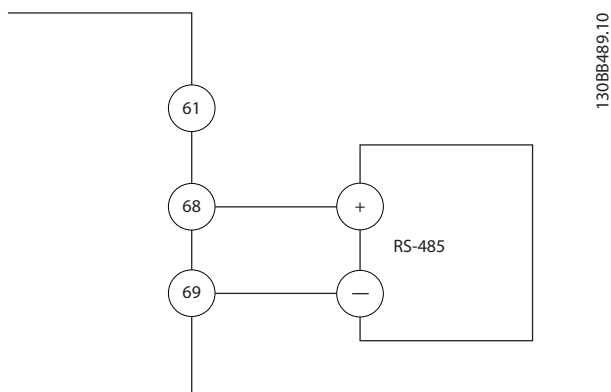

Illustration 4.12 Serial Communication Wiring Diagram

For basic serial communication set-up, select the following:

1. Protocol type in 8-30 *Protocol*.
 2. Frequency converter address in 8-31 *Address*.
 3. Baud rate in 8-32 *Baud Rate*.
- 2 communication protocols are internal to the frequency converter.
 - Danfoss FC
 - Modbus RTU
 - Functions can be programmed remotely using the protocol software and RS-485 connection or in parameter group 8-** *Communications and Options*
 - Selecting a specific communication protocol changes various default parameter settings to match that protocol's specifications along with making additional protocol-specific parameters available
 - Option cards which install into the frequency converter are available to provide additional communication protocols. See the option-card documentation for installation and operation instructions

4.9 Installation Check List

Before completing installation of the unit, inspect the entire installation as detailed in *Table 4.5*. Check and mark the items when completed.

Inspect for	Description	<input checked="" type="checkbox"/>
Auxiliary equipment	<ul style="list-style-type: none"> Look for auxiliary equipment, switches, disconnects, or input fuses/circuit breakers that may reside on the input power side of the frequency converter or output side to the motor. Ensure that they are ready for full-speed operation Check function and installation of any sensors used for feedback to the frequency converter Remove any power factor correction caps on motor(s) Adjust any power factor correction caps on the mains side and ensure that they are dampened 	
Cable routing	<ul style="list-style-type: none"> Ensure that motor wiring and control wiring are separated or screened or in 3 separate metallic conduits for high-frequency interference isolation 	
Control wiring	<ul style="list-style-type: none"> Check for broken or damaged wires and loose connections Check that control wiring is isolated from power and motor wiring for noise immunity Check the voltage source of the signals, if necessary The use of screened cable or twisted pair is recommended. Ensure that the shield is terminated correctly 	
Cooling clearance	<ul style="list-style-type: none"> Measure that top and bottom clearance is adequate to ensure proper air flow for cooling, see <i>3.3 Mounting</i> 	
Ambient conditions	<ul style="list-style-type: none"> Check that requirements for ambient conditions are met 	
Fusing and circuit breakers	<ul style="list-style-type: none"> Check for proper fusing or circuit breakers Check that all fuses are inserted firmly and are in operational condition and that all circuit breakers are in the open position 	
Grounding	<ul style="list-style-type: none"> Check for good ground connections that are tight and free of oxidation Grounding to conduit, or mounting the back panel to a metal surface, is not a suitable grounding 	
Input and output power wiring	<ul style="list-style-type: none"> Check for loose connections Check that motor and mains are in separate conduit or separated screened cables 	
Panel interior	<ul style="list-style-type: none"> Inspect that the unit interior is free of dirt, metal chips, moisture, and corrosion Check that the unit is mounted on an unpainted, metal surface 	
Switches	<ul style="list-style-type: none"> Ensure that all switch and disconnect settings are in the proper positions 	
Vibration	<ul style="list-style-type: none"> Check that the unit is mounted solidly, or that shock mounts are used, as necessary Check for an unusual amount of vibration 	

Table 4.5 Installation Check List

CAUTION

POTENTIAL HAZARD IN THE EVENT OF INTERNAL FAILURE!

Risk of personal injury when the frequency converter is not properly closed. Before applying power, ensure all safety covers are in place and securely fastened.

5 Commissioning

5.1 Safety Instructions

See 2 *Safety* for general safety instructions.

⚠ WARNING

HIGH VOLTAGE!

Frequency converters contain high voltage when connected to AC mains input power. Installation, start-up, and maintenance must be performed by qualified personnel only. Failure to perform installation, start-up, and maintenance by qualified personnel could result in death or serious injury.

Before applying power:

1. Close cover properly.
2. Check that all cable glands are firmly tightened.
3. Ensure that input power to the unit is OFF and locked out. Do not rely on the frequency converter disconnect switches for input power isolation.
4. Verify that there is no voltage on input terminals L1 (91), L2 (92), and L3 (93), phase-to-phase and phase-to-ground.
5. Verify that there is no voltage on output terminals 96 (U), 97 (V), and 98 (W), phase-to-phase and phase-to-ground.
6. Confirm continuity of the motor by measuring ohm values on U-V (96-97), V-W (97-98), and W-U (98-96).
7. Check for proper grounding of the frequency converter as well as the motor.
8. Inspect the frequency converter for loose connections on terminals.
9. Confirm that the supply voltage matches voltage of frequency converter and motor.

5.2 Applying Power

⚠ WARNING

UNINTENDED START!

When the frequency converter is connected to AC mains, the motor may start at any time. The frequency converter, motor, and any driven equipment must be in operational readiness. Failure to be in operational readiness when the frequency converter is connected to AC mains could result in death, serious injury, equipment or property damage.

1. Confirm that the input voltage is balanced within 3%. If not, correct input voltage imbalance before proceeding. Repeat this procedure after the voltage correction.
2. Ensure that optional equipment wiring, if present, matches the installation application.
3. Ensure that all operator devices are in the OFF position. Panel doors must be closed or cover mounted.
4. Apply power to the unit. DO NOT start the frequency converter at this time. For units with a disconnect switch, turn to the ON position to apply power to the frequency converter.

NOTICE

If the status line at the bottom of the LCP reads **AUTO REMOTE COASTING** or **Alarm 60 External Interlock** is displayed, this indicates that the unit is ready to operate but is missing an input signal on terminal 27. See 4.8.3 *Enabling Motor Operation (Terminal 27)* for details.

5.3 Local Control Panel Operation

5.3.1 Local Control Panel

The local control panel (LCP) is the combined display and keypad on the front of the unit.

The LCP has several user functions:

- Start, stop, and control speed when in local control
- Display operational data, status, warnings and cautions
- Programming frequency converter functions
- Manually reset the frequency converter after a fault when auto-reset is inactive

An optional numeric LCP (NLCP) is also available. The NLCP operates in a manner similar to the LCP. See the *Programming Guide* for details on use of the NLCP.

NOTICE

For commissioning via PC, install MCT 10 Set-up Software. The software is available for download at www.danfoss.com/BusinessAreas/DrivesSolutions/Software-download (basic version) or for ordering (advanced version, order number 130B1000).

5.3.2 LCP Layout

The LCP is divided into 4 functional groups (see *Illustration 5.1*).

- A. Display area
- B. Display menu keys
- C. Navigation keys and indicator lights (LEDs)
- D. Operation keys and reset

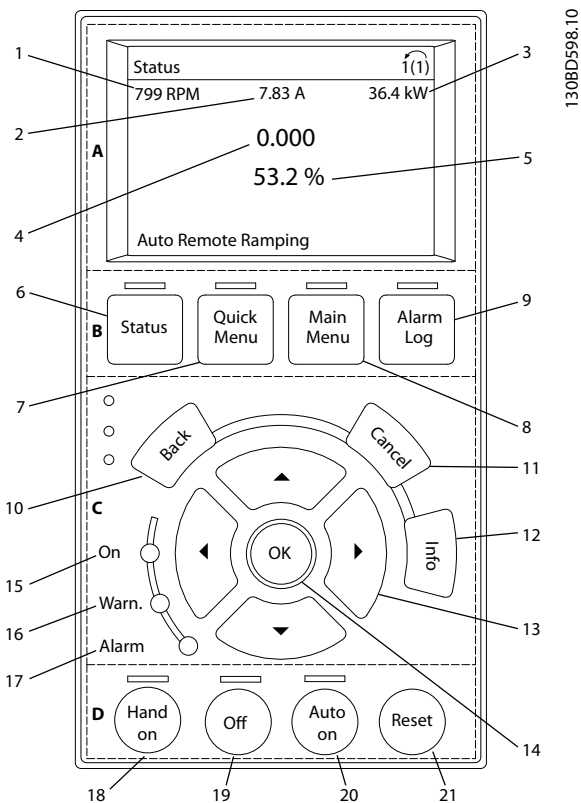

Illustration 5.1 Local Control Panel (LCP)

A. Display area

The display area is activated when the frequency converter receives power from mains voltage, a DC bus terminal, or an external 24 V DC supply.

The information displayed on the LCP can be customised for user application. Select options in the Quick Menu Q3-13 *Display Settings*.

Display	Parameter number	Default setting
1	0-20	Speed [RPM]
2	0-21	Motor Current
3	0-22	Power [kW]
4	0-23	Frequency
5	0-24	Reference [%]

Table 5.1 Legend to *Illustration 5.1*, Display Area

B. Display menu keys

Menu keys are used for menu access for parameter set-up, toggling through status display modes during normal operation, and viewing fault log data.

	Key	Function
6	Status	Shows operational information.
7	Quick Menu	Allows access to programming parameters for initial set-up instructions and many detailed application instructions.
8	Main Menu	Allows access to all programming parameters.
9	Alarm Log	Displays a list of current warnings, the last 10 alarms, and the maintenance log.

Table 5.2 Legend to *Illustration 5.1*, Display Menu Keys

C. Navigation keys and indicator lights (LEDs)

Navigation keys are used for programming functions and moving the display cursor. The navigation keys also provide speed control in local operation. There are also 3 frequency converter status indicator lights in this area.

	Key	Function
10	Back	Reverts to the previous step or list in the menu structure.
11	Cancel	Cancels the last change or command as long as the display mode has not changed.
12	Info	Press for a definition of the function being displayed.
13	Navigation Keys	Use the 4 navigation keys to move between items in the menu.
14	OK	Use to access parameter groups or to enable a choice.

Table 5.3 Legend to *Illustration 5.1*, Navigation Keys

	Indicator	Light	Function
15	On	Green	The ON light activates when the frequency converter receives power from mains voltage, a DC bus terminal, or an external 24 V supply.
16	Warn	Yellow	When warning conditions are met, the yellow WARN light comes on and text appears in the display area identifying the problem.
17	Alarm	Red	A fault condition causes the red alarm light to flash and an alarm text is displayed.

Table 5.4 Legend to *Illustration 5.1*, Indicator Lights (LEDs)

D. Operation keys and reset

Operation keys are located at the bottom of the LCP.

	Key	Function
18	Hand On	Starts the frequency converter in local control. <ul style="list-style-type: none"> An external stop signal by control input or serial communication overrides the local hand on
19	Off	Stops the motor but does not remove power to the frequency converter.
20	Auto On	Puts the system in remote operational mode. <ul style="list-style-type: none"> Responds to an external start command by control terminals or serial communication
21	Reset	Resets the frequency converter manually after a fault has been cleared.

Table 5.5 Legend to *Illustration 5.1, Operation Keys and Reset***NOTICE**

The display contrast can be adjusted by pressing [Status] and [▲]/[▼] keys.

5.3.3 Parameter Settings

Establishing the correct programming for applications often requires setting functions in several related parameters. Details for parameters are provided in *9.2 Parameter Menu Structure*.

Programming data are stored internally in the frequency converter.

- For backup, upload data into the LCP memory
- To download data to another frequency converter, connect the LCP to that unit and download the stored settings
- Restoring factory default settings does not change data stored in the LCP memory

5.3.4 Uploading/Downloading Data to/from the LCP

- Press [Off] to stop the motor before uploading or downloading data.
- Go to [Main Menu] *0-50 LCP Copy* and Press [OK].
- Select *All to LCP* to upload data to LCP or select *All from LCP* to download data from the LCP.
- Press [OK]. A progress bar shows the uploading or downloading process.
- Press [Hand On] or [Auto On] to return to normal operation.

5.3.5 Changing Parameter Settings

View changes

Quick Menu Q5 - Changes Made lists all parameters changed from default settings.

- The list shows only parameters which have been changed in the current edit-setup.
- Parameters which have been reset to default values are not listed.
- The message 'Empty' indicates that no parameters have been changed.

Changing settings

Parameter settings can be accessed and changed from the [Quick Menu] or from the [Main Menu]. The [Quick Menu] only gives access to a limited number of parameters.

- Press [Quick Menu] or [Main Menu] on the LCP.
- Press [▲] [▼] to browse through the parameter groups, press [OK] to select a parameter group.
- Press [▲] [▼] to browse through the parameters, press [OK] to select a parameter.
- Press [▲] [▼] to change the value of a parameter setting.
- Press [◀] [▶] to shift digit when a decimal parameter is in the editing state.
- Press [OK] to accept the change.
- Press either [Back] twice to enter "Status", or press [Main Menu] once to enter "Main Menu".

5.3.6 Restoring Default Settings

NOTICE

Risk of losing programming, motor data, localisation, and monitoring records by restoration of default settings. To provide a backup, upload data to the LCP before initialisation.

Restoring the default parameter settings is done by initialisation of the frequency converter. Initialisation is carried out through *14-22 Operation Mode* (recommended) or manually.

- Initialisation using *14-22 Operation Mode* does not reset frequency converter settings such as operating hours, serial communication selections, personal menu settings, fault log, alarm log, and other monitoring functions.
- Manual initialisation erases all motor, programming, localisation, and monitoring data and restores factory default settings.

5

Recommended initialisation procedure, via 14-22 Operation Mode

1. Press [Main Menu] twice to access parameters.
2. Scroll to *14-22 Operation Mode* and press [OK].
3. Scroll to *Initialisation* and press [OK].
4. Remove power to the unit and wait for the display to turn off.
5. Apply power to the unit.

Default parameter settings are restored during start-up. This may take slightly longer than normal.

6. Alarm 80 is displayed.
7. Press [Reset] to return to operation mode.

Manual initialisation procedure

1. Remove power to the unit and wait for the display to turn off.
2. Press and hold [Status], [Main Menu], and [OK] at the same time while applying power to the unit (approximately 5 s or until audible click and fan starts).

Factory default parameter settings are restored during start-up. This may take slightly longer than normal.

Manual initialisation does not reset the following frequency converter information:

- 15-00 Operating hours
- 15-03 Power Up's
- 15-04 Over Temp's
- 15-05 Over Volt's

5.4 Basic Programming

5.4.1 Commissioning with SmartStart

The SmartStart wizard enables fast configuration of basic motor and application parameters.

- At first power up or after initialisation of the frequency converter, SmartStart starts by itself.
- Follow on-screen instructions to complete commissioning of the frequency converter. SmartStart can always be reactivated by selecting *Quick Menu Q4 - SmartStart*.
- For commissioning without use of the SmartStart wizard, refer to *5.4.2 Commissioning via [Main Menu]* or the *Programming Guide*.

NOTICE

Motor data are required for the SmartStart setup. The required data are normally available on the motor nameplate.

5.4.2 Commissioning via [Main Menu]

Recommended parameter settings are intended for start-up and checkout purposes. Application settings may vary.

Enter data with power ON, but before operating the frequency converter.

1. Press [Main Menu] on the LCP.
2. Use the navigation keys to scroll to parameter group *0-** Operation/Display* and press [OK].

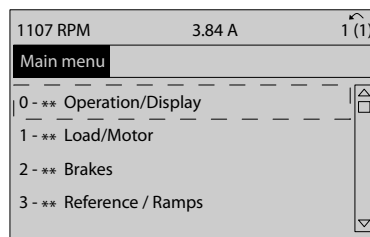

130BP066.10

Illustration 5.2 Main Menu

3. Use navigation keys to scroll to parameter group *0-0* Basic Settings* and press [OK].

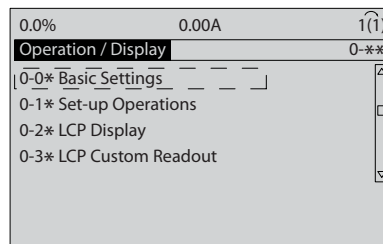

130BP087.10

Illustration 5.3 Operation/Display

4. Use navigation keys to scroll to *0-03 Regional Settings* and press [OK].

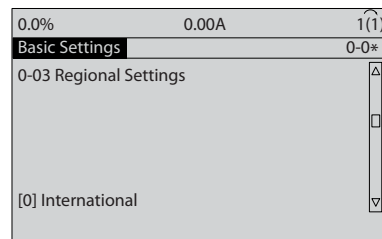

130BP088.10

Illustration 5.4 Basic Settings

5. Use navigation keys to select *[0] International* or *[1] North America* as appropriate and press [OK]. (This changes the default settings for a number of basic parameters).
6. Press [Main Menu] on the LCP.

7. Use the navigation keys to scroll to *0-01 Language*.
8. Select language and press [OK].
9. If a jumper wire is in place between control terminals 12 and 27, leave *5-12 Terminal 27 Digital Input* at factory default. Otherwise, select *No Operation* in *5-12 Terminal 27 Digital Input*. For frequency converters with an optional bypass, no jumper wire is required between control terminals 12 and 27.
10. *3-02 Minimum Reference*
11. *3-03 Maximum Reference*
12. *3-41 Ramp 1 Ramp Up Time*
13. *3-42 Ramp 1 Ramp Down Time*
14. *3-13 Reference Site*. Linked to Hand/Auto Local Remote.

5.4.3 Asynchronous Motor Setup

Enter the motor data in parameters 1-20 or 1-21 to 1-25. The information can be found on the motor nameplate.

1. *1-20 Motor Power [kW] or 1-21 Motor Power [HP]*
2. *1-22 Motor Voltage*
3. *1-23 Motor Frequency*
4. *1-24 Motor Current*
5. *1-25 Motor Nominal Speed*

5.4.4 PM Motor Setup in VVC^{plus}

Initial Programming Steps

1. Activate PM motor operation *1-10 Motor Construction*, select (1) *PM, non salient SPM*
2. Set *0-02 Motor Speed Unit* to [0] *RPM*

Programming motor data

After selecting PM motor in *1-10 Motor Construction*, the PM motor-related parameters in parameter groups *1-2**, *1-3** and *1-4** are active.

The necessary data can be found on the motor nameplate and in the motor data sheet.

Program the following parameters in the listed order

1. *1-24 Motor Current*
2. *1-26 Motor Cont. Rated Torque*
3. *1-25 Motor Nominal Speed*
4. *1-39 Motor Poles*
5. *1-30 Stator Resistance (Rs)*
Enter line to common stator winding resistance (Rs). If only line-line data are available, divide the

line-line value with 2 to achieve the line to common (starpoint) value.

6. *1-37 d-axis Inductance (Ld)*
Enter line to common direct axis inductance of the PM motor.
If only line-line data are available, divide the line-line value with 2 to achieve the line-common (starpoint) value.
7. *1-40 Back EMF at 1000 RPM*
Enter line to line back EMF of PM Motor at 1000 RPM mechanical speed (RMS value). Back EMF is the voltage generated by a PM motor when no drive is connected and the shaft is turned externally. Back EMF is normally specified for nominal motor speed or for 1000 RPM measured between 2 lines. If the value is not available for a motor speed of 1000 RPM, calculate the correct value as follows: If back EMF is e.g. 320 V at 1800 RPM, it can be calculated at 1000 RPM as follows: $\text{Back EMF} = (\text{Voltage} / \text{RPM}) * 1000 = (320/1800) * 1000 = 178$. This is the value that must be programmed for *1-40 Back EMF at 1000 RPM*.

Test Motor Operation

1. Start the motor at low speed (100 to 200 RPM). If the motor does not turn, check installation, general programming and motor data.
2. Check if start function in *1-70 PM Start Mode* fits the application requirements.

Rotor detection

This function is the recommended choice for applications where the motor starts from standstill, e.g. pumps or conveyors. On some motors, an acoustic sound is heard when the impulse is sent out. This does not harm the motor.

Parking

This function is the recommended choice for applications where the motor is rotating at slow speed e.g. windmilling in fan applications. *2-06 Parking Current* and *2-07 Parking Time* can be adjusted. Increase the factory setting of these parameters for applications with high inertia.

Start the motor at nominal speed. If the application does not run well, check the VVC^{plus} PM settings. Recommendations in different applications can be seen in *Table 5.6*.

Application	Settings
Low inertia applications $I_{Load}/I_{Motor} < 5$	1-17 <i>Voltage filter time const.</i> to be increased by factor 5 to 10 1-14 <i>Damping Gain</i> should be reduced 1-66 <i>Min. Current at Low Speed</i> should be reduced (<100%)
Low inertia applications $50 > I_{Load}/I_{Motor} > 5$	Keep calculated values
High inertia applications $I_{Load}/I_{Motor} > 50$	1-14 <i>Damping Gain</i> , 1-15 <i>Low Speed Filter Time Const.</i> and 1-16 <i>High Speed Filter Time Const.</i> should be increased
High load at low speed <30% (rated speed)	1-17 <i>Voltage filter time const.</i> should be increased 1-66 <i>Min. Current at Low Speed</i> should be increased (>100% for a prolonged time can overheat the motor)

Table 5.6 Recommendations in Different Applications

If the motor starts oscillating at a certain speed, increase 1-14 *Damping Gain*. Increase the value in small steps. Depending on the motor, a good value for this parameter can be 10% or 100% higher than the default value.

Starting torque can be adjusted in 1-66 *Min. Current at Low Speed*. 100% provides nominal torque as starting torque.

5.4.5 Automatic Motor Adaptation (AMA)

NOTICE

AMA is not relevant for permanent magnet motors.

Automatic motor adaptation (AMA) is a procedure that optimises compatibility between the frequency converter and the motor.

- The frequency converter builds a mathematical model of the motor for regulating output motor current. The procedure also tests the input phase balance of electrical power. It compares the motor characteristics with the data entered in parameters 1-20 to 1-25
- The motor shaft does not turn and no harm is done to the motor while running the AMA
- Some motors may be unable to run the complete version of the test. In that case, select [2] *Enable reduced AMA*
- If an output filter is connected to the motor, select *Enable reduced AMA*
- If warnings or alarms occur, see 7.4 *List of Warnings and Alarms*

- Run this procedure on a cold motor for best results

To run AMA

1. Press [Main Menu] to access parameters.
2. Scroll to parameter group 1-** *Load and Motor* and press [OK].
3. Scroll to parameter group 1-2* *Motor Data* and press [OK].
4. Scroll to 1-29 *Automatic Motor Adaptation (AMA)* and press [OK].
5. Select [1] *Enable complete AMA* and press [OK].
6. Follow on-screen instructions.
7. The test runs automatically and indicate when it is complete.

5.5 Checking Motor Rotation

Before running the frequency converter, check the motor rotation.

1. Press [Hand On].
2. Press [►] for positive speed reference.
3. Check that the speed displayed is positive.

When 1-06 *Clockwise Direction* is set to [0] *Normal* (default clockwise):

- 4a. Verify that the motor turns clockwise.
- 5a. Verify that the LCP direction arrow is clockwise.

When 1-06 *Clockwise Direction* is set to [1] *Inverse* (counter-clockwise):

- 4b. Verify that the motor turns counter-clockwise.
- 5b. Verify that the LCP direction arrow is counter-clockwise.

5.6 Checking Encoder Rotation

NOTICE

When using an encoder option, refer to the option manual.

Check encoder rotation only if encoder feedback is used. Check encoder rotation in default open loop control.

1. Verify that the encoder connection is according to *Illustration 5.5*:

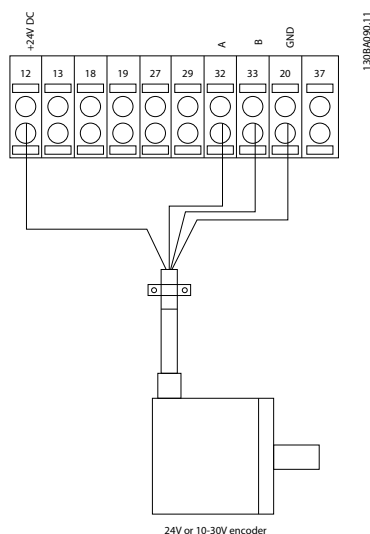

Illustration 5.5 Wiring Diagram

2. Enter the Speed PID feed-back source in *7-00 Speed PID Feedback Source*.
3. Press [Hand On].
4. Press [▶] for positive speed reference (*1-06 Clockwise Direction* at [0] Normal).
5. Check in *16-57 Feedback [RPM]* that the feed-back is positive.

NOTICE

If the feedback is negative, the encoder connection is wrong!

5.7 Local-control Test

WARNING**MOTOR START!**

Ensure that the motor, system, and any attached equipment are ready for start. It is the responsibility of the user to ensure safe operation under any condition. Failure to ensure that the motor, system, and any attached equipment is ready for start could result in personal injury or equipment damage.

1. Press [Hand On] to provide a local start command to the frequency converter.
2. Accelerate the frequency converter by pressing [▲] to full speed. Moving the cursor left of the decimal point provides quicker input changes.
3. Note any acceleration problems.
4. Press [Off]. Note any deceleration problems.

In the event of acceleration or deceleration problems, see *7.5 Troubleshooting*. See *7.4 List of Warnings and Alarms* for resetting the frequency converter after a trip.

5.8 System Start-up

The procedure in this section requires user-wiring and application programming to be completed. The following procedure is recommended after application set-up is completed.

WARNING**MOTOR START!**

Ensure that the motor, system, and any attached equipment are ready for start. It is the responsibility of the user to ensure safe operation under any condition. Failure to ensure that the motor, system, and any attached equipment is ready for start could result in personal injury or equipment damage.

1. Press [Auto On].
2. Apply an external run command.
3. Adjust the speed reference throughout the speed range.
4. Remove the external run command.
5. Check sound and vibration level of the motor to ensure that the system is working as intended.

If warnings or alarms occur, see *7.4 List of Warnings and Alarms*.

6 Application Set-up Examples

The examples in this section are intended as a quick reference for common applications.

- Parameter settings are the regional default values unless otherwise indicated (selected in *0-03 Regional Settings*)
- Parameters associated with the terminals and their settings are shown next to the drawings
- Where switch settings for analog terminals A53 or A54 are required, these are also shown

6

NOTICE

When the optional Safe Torque Off feature is used, a jumper wire may be required between terminal 12 (or 13) and terminal 37 for the frequency converter to operate when using factory default programming values.

6.1 Application Examples

6.1.1 AMA

FC		Parameters		
		Function	Setting	
+24 V	12	130BB929.10	1-29 Automatic Motor Adaptation (AMA)	
+24 V	13			[1] Enable complete AMA
D IN	18			
D IN	19			5-12 Terminal 27 Digital Input
COM	20		[2]* Coast inverse	
D IN	27			* = Default Value
D IN	29			Notes/comments: Parameter group 1-2* must be set according to motor D IN 37 is an option.
D IN	32			
D IN	33			
D IN	37			
D IN	39			
+10 V	50			
A IN	53			
A IN	54			
COM	55			
A OUT	42			
COM	39			

Table 6.1 AMA with T27 Connected

FC		Parameters		
		Function	Setting	
+24 V	12	130BB930.10	1-29 Automatic Motor Adaptation (AMA)	
+24 V	13			[1] Enable complete AMA
D IN	18			
D IN	19			5-12 Terminal 27 Digital Input
COM	20		[0] No operation	
D IN	27			* = Default Value
D IN	29			Notes/comments: Parameter group 1-2* must be set according to motor D IN 37 is an option.
D IN	32			
D IN	33			
D IN	37			
D IN	39			
+10 V	50			
A IN	53			
A IN	54			
COM	55			
A OUT	42			
COM	39			

Table 6.2 AMA without T27 Connected

6.1.2 Speed

FC		Parameters		
		Function	Setting	
+24 V	12	130BB926.10	6-10 Terminal 53 Low Voltage	
+24 V	13			0.07 V*
D IN	18		6-11 Terminal 53 High Voltage	
D IN	19			10 V*
COM	20		6-14 Terminal 53 Low Ref./Feedb. Value	
D IN	27			0 Hz
D IN	29		6-15 Terminal 53 High Ref./Feedb. Value	
D IN	32			50 Hz
D IN	33			* = Default Value
D IN	37			Notes/comments: D IN 37 is an option.
D IN	39			
+10 V	50			
A IN	53			
A IN	54			
COM	55			
A OUT	42			
COM	39			

Table 6.3 Analog Speed Reference (Voltage)

FC		Parameters		
		Function	Setting	
+24 V	12	6-12 Terminal 53 <i>Low Current</i>	4 mA*	
+24 V	13		6-13 Terminal 53 <i>High Current</i>	20 mA*
D IN	18			6-14 Terminal 53 <i>Low Ref./Feedb. Value</i>
D IN	19		6-15 Terminal 53 <i>High Ref./Feedb. Value</i>	
COM	20			* = Default Value
D IN	27	Notes/comments: D IN 37 is an option.		
D IN	29			
D IN	32			
D IN	33			
D IN	37			
+10 V	50	Notes/comments: D IN 37 is an option.		
A IN	53			
A IN	54			
COM	55			
A OUT	42			
COM	39			

Table 6.4 Analog Speed Reference (Current)

FC		Parameters		
		Function	Setting	
+24 V	12	5-10 Terminal 18 <i>Digital Input</i>	[8] Start*	
+24 V	13		5-12 Terminal 27 <i>Digital Input</i>	[19] Freeze Reference
D IN	18			5-13 Terminal 29 <i>Digital Input</i>
D IN	19		5-14 Terminal 32 <i>Digital Input</i>	
COM	20	* = Default Value		
D IN	27	Notes/comments: D IN 37 is an option.		
D IN	29			
D IN	32			
D IN	33			
D IN	37			
+10 V	50	Notes/comments: D IN 37 is an option.		
A IN	53			
A IN	54			
COM	55			
A OUT	42			
COM	39			

Table 6.6 Speed Up/Down

FC		Parameters	
		Function	Setting
+24 V	12	6-10 Terminal 53 <i>Low Voltage</i>	0.07 V*
+24 V	13		6-11 Terminal 53 <i>High Voltage</i>
D IN	18	6-14 Terminal 53 <i>Low Ref./Feedb. Value</i>	
D IN	19		6-15 Terminal 53 <i>High Ref./Feedb. Value</i>
COM	20	* = Default Value	
D IN	27	Notes/comments: D IN 37 is an option.	
D IN	29		
D IN	32		
D IN	33		
D IN	37		
+10 V	50	Notes/comments: D IN 37 is an option.	
A IN	53		
A IN	54		
COM	55		
A OUT	42		
COM	39		

Table 6.5 Speed Reference (Using a Manual Potentiometer)

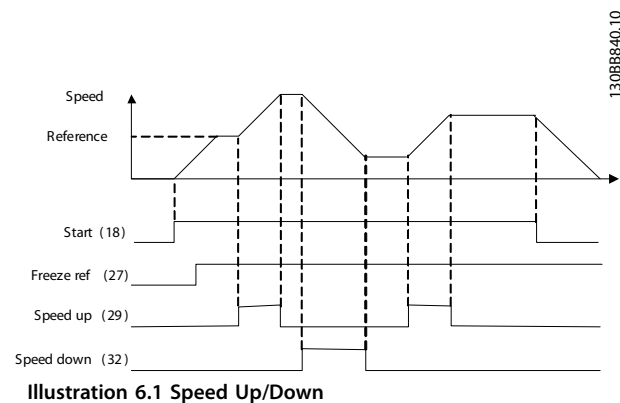

Illustration 6.1 Speed Up/Down

6.1.3 Start/Stop

		Parameters	
FC		Function	Setting
+24 V	12		
+24 V	13		
D IN	18	5-10 Terminal 18 Digital Input	[8] Start*
D IN	19		
COM	20		
D IN	27	5-12 Terminal 27 Digital Input	[0] No operation
D IN	29		
D IN	32		
D IN	33	5-19 Terminal 37 Safe Stop	[1] Safe Stop Alarm
D IN	37		
* = Default Value			
Notes/comments: If 5-12 Terminal 27 Digital Input is set to [0] No operation, a jumper wire to terminal 27 is not needed. D IN 37 is an option.			
+10	50		
A IN	53		
A IN	54		
COM	55		
A OUT	42		
COM	39		

Table 6.7 Start/Stop Command with Safe Stop Option

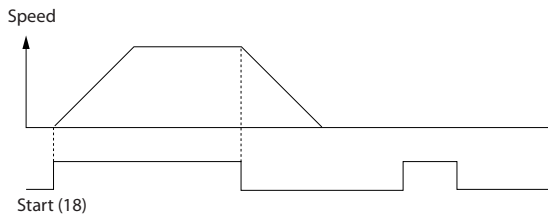

Illustration 6.2 Start/Stop Command with Safe Stop

		Parameters	
FC		Function	Setting
+24 V	12		
+24 V	13		
D IN	18	5-10 Terminal 18 Digital Input	[9] Latched Start
D IN	19		
COM	20		
D IN	27	5-12 Terminal 27 Digital Input	[6] Stop Inverse
D IN	29		
D IN	32		
D IN	33		
D IN	37		
* = Default Value			
Notes/comments: If 5-12 Terminal 27 Digital Input is set to [0] No operation, a jumper wire to terminal 27 is not needed. D IN 37 is an option.			
+10 V	50		
A IN	53		
A IN	54		
COM	55		
A OUT	42		
COM	39		

Table 6.8 Pulse Start/Stop

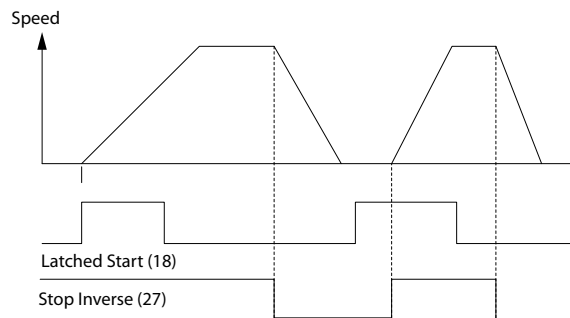

Illustration 6.3 Latched Start/Stop Inverse

		Parameters	
		Function	Setting
		5-10 Terminal 18 Digital Input	[8] Start
		5-11 Terminal 19 Digital Input	[10] Reversing*
		5-12 Terminal 27 Digital Input	[0] No operation
		5-14 Terminal 32 Digital Input	[16] Preset ref bit 0
		5-15 Terminal 33 Digital Input	[17] Preset ref bit 1
		3-10 Preset Reference	
		Preset ref. 0	25%
		Preset ref. 1	50%
		Preset ref. 2	75%
		Preset ref. 3	100%
		* = Default Value	
		Notes/comments: D IN 37 is an option.	

Table 6.9 Start/Stop with Reversing and 4 Preset Speeds

6.1.4 External Alarm Reset

		Parameters	
		Function	Setting
		5-11 Terminal 19 Digital Input	[1] Reset
		* = Default Value	
		Notes/comments: D IN 37 is an option.	

Table 6.10 External Alarm Reset

6.1.5 RS-485

		Parameters	
		Function	Setting
		8-30 Protocol	FC*
		8-31 Address	1*
		8-32 Baud Rate	9600*
		* = Default Value	
		Notes/comments: Select protocol, address and baud rate in the above mentioned parameters. D IN 37 is an option.	

Table 6.11 RS-485 Network Connection

6.1.6 Motor Thermistor

CAUTION

Use only thermistors with reinforced or double insulation to meet PELV insulation requirements.

VLT		Parameters	
Function	Setting	Function	Setting
+24 V	12	130BB686.12	1-90 Motor Thermal Protection
+24 V	13		[2]
D IN	18		Thermistor trip
D IN	19		1-93 Thermistor Source
COM	20		[1] Analog input 53
D IN	27		* = Default Value
D IN	29		Notes/comments:
D IN	32		If only a warning is desired, 1-90 Motor Thermal Protection should be set to [1] Thermistor warning.
D IN	33		D IN 37 is an option.
D IN	37		
+10 V	50		
A IN	53		
A IN	54		
COM	55		
A OUT	42		
COM	39		
U - I		A53	

Table 6.12 Motor Thermistor

6.1.7 SLC

FC		Parameters	
Function	Setting	Function	Setting
+24 V	12	130BB839.10	4-30 Motor Feedback Loss Function
+24 V	13		[1] Warning
D IN	18		4-31 Motor Feedback Speed Error
D IN	19		100 RPM
COM	20		4-32 Motor Feedback Loss Timeout
D IN	27		5 s
D IN	29		7-00 Speed PID Feedback Source
D IN	32		[2] MCB 102
D IN	33		17-11 Resolution (PPR)
D IN	37		1024*
+10 V	50	13-00 SL Controller Mode	
A IN	53	[1] On	
A IN	54	13-01 Start Event	
COM	55	[19] Warning	
A OUT	42	13-02 Stop Event	
COM	39	[44] Reset key	
RE	01	13-10 Comparator Operand	
	02	[21] Warning no.	
	03	13-11 Comparator Operator	
	04	[1] ≈*	
RE	05	13-12 Comparator Value	
	06	90	
		13-51 SL Controller Event	
		[22] Comparator 0	
		13-52 SL Controller Action	
		[32] Set digital out A low	
		5-40 Function Relay	
		[80] SL digital output A	
* = Default Value			
Notes/comments:			
If the limit in the feedback monitor is exceeded, Warning 90 will be issued. The SLC monitors Warning 90 and in the case that Warning 90 becomes TRUE then Relay 1 is triggered.			
External equipment may then indicate that service may be required. If the feedback error goes below the limit again within 5 s then the frequency converter continues and the warning disappears. But Relay 1 will still be triggered until [Reset] on the LCP.			

Table 6.13 Using SLC to Set a Relay

6.1.8 Mechanical Brake Control

		Parameters	
		Function	Setting
		5-40 Function Relay	[32] Mech. brake ctrl.
		5-10 Terminal 18 Digital Input	[8] Start*
		5-11 Terminal 19 Digital Input	[11] Start reversing
		1-71 Start Delay	0.2
		1-72 Start Function	[5] VVC ^{plus} /FLUX Clockwise
		1-76 Start Current	$I_{m,n}$
		2-20 Release Brake Current	App. dependent
		2-21 Activate Brake Speed [RPM]	Half of nominal slip of the motor
		* = Default Value	
		Notes/comments:	

6

Table 6.14 Mechanical Brake Control

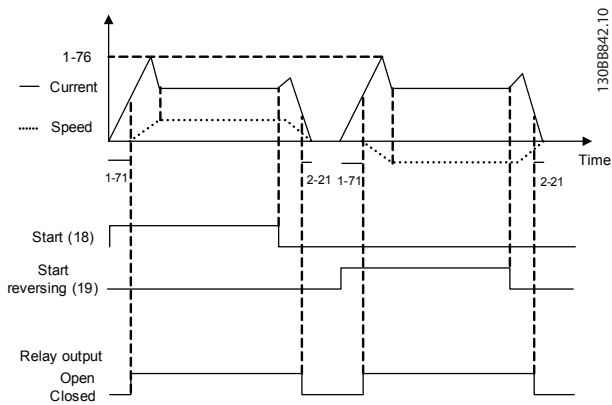

Illustration 6.4 Mechanical Brake Control

7 Diagnostics and Troubleshooting

This chapter includes maintenance and service guidelines, status messages, warnings and alarms and basic troubleshooting.

7.1 Maintenance and Service

Under normal operating conditions and load profiles, the frequency converter is maintenance-free throughout its designed lifetime. To prevent breakdown, danger, and damage, examine the frequency converter at regular intervals depending on the operating conditions. Replace worn or damaged parts with original spare parts or standard parts. For service and support, refer to www.danfoss.com/contact/sales_and_services/.

CAUTION

Danfoss AUTHORISED PERSONNEL!

Risk of personal injury or equipment damage. Repair and service must be carried out by Danfoss authorised personnel only.

7.2 Status Messages

When the frequency converter is in status mode, status messages are generated automatically and appear in the bottom line of the display (see *Illustration 7.1*).

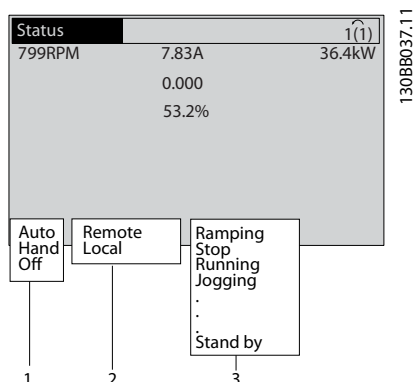

Illustration 7.1 Status Display

1	Operation Mode (see <i>Table 7.2</i>)
2	Reference Site (see <i>Table 7.3</i>)
3	Operation Status (see <i>Table 7.4</i>)

Table 7.1 Legend to *Illustration 7.1*

Table 7.2 to Table 7.4 describe the displayed status messages.

Off	The frequency converter does not react to any control signal until [Auto On] or [Hand On] is pressed.
Auto On	The frequency converter is controlled from the control terminals and/or the serial communication.
Hand On	The frequency converter is controlled by the navigation keys on the LCP. Stop commands, reset, reversing, DC brake, and other signals applied to the control terminals will override local control.

Table 7.2 Operation Mode

Remote	The speed reference is given from external signals, serial communication, or internal preset references.
Local	The frequency converter uses [Hand On] control or reference values from the LCP.

Table 7.3 Reference Site

AC Brake	AC Brake was selected in <i>2-10 Brake Function</i> . The AC brake over-magnetizes the motor to achieve a controlled slow-down.
AMA finish OK	Automatic motor adaptation (AMA) was carried out successfully.
AMA ready	AMA is ready to start. Press [Hand On] to start.
AMA running	AMA process is in progress.
Braking	The brake chopper is in operation. Generative energy is absorbed by the brake resistor.
Braking max.	The brake chopper is in operation. The power limit for the brake resistor defined in <i>2-12 Brake Power Limit (kW)</i> has been reached.
Coast	<ul style="list-style-type: none"> Coast inverse was selected as a function for a digital input (parameter group 5-1* <i>Digital Inputs</i>). The corresponding terminal is not connected. Coast activated by serial communication
Ctrl. Ramp-down	Control Ramp-down was selected in <i>14-10 Mains Failure</i> . <ul style="list-style-type: none"> The mains voltage is below the value set in <i>14-11 Mains Voltage at Mains Fault</i> at mains fault The frequency converter ramps down the motor using a controlled ramp down
Current High	The frequency converter output current is above the limit set in <i>4-51 Warning Current High</i> .
Current Low	The frequency converter output current is below the limit set in <i>4-52 Warning Speed Low</i>

DC Hold	DC hold is selected in <i>1-80 Function at Stop</i> and a stop command is active. The motor is held by a DC current set in <i>2-00 DC Hold/ Preheat Current</i> .
DC Stop	The motor is held with a DC current (<i>2-01 DC Brake Current</i>) for a specified time (<i>2-02 DC Braking Time</i>). <ul style="list-style-type: none"> DC Brake is activated in <i>2-03 DC Brake Cut In Speed [RPM]</i> and a stop command is active. DC Brake (inverse) is selected as a function for a digital input (parameter group <i>5-1* Digital Inputs</i>). The corresponding terminal is not active. The DC Brake is activated via serial communication.
Feedback high	The sum of all active feedbacks is above the feedback limit set in <i>4-57 Warning Feedback High</i> .
Feedback low	The sum of all active feedbacks is below the feedback limit set in <i>4-56 Warning Feedback Low</i> .
Freeze output	The remote reference is active, which holds the present speed. <ul style="list-style-type: none"> Freeze output was selected as a function for a digital input (parameter group <i>5-1* Digital Inputs</i>). The corresponding terminal is active. Speed control is only possible via the terminal functions Speed Up and Speed Down. Hold ramp is activated via serial communication.
Freeze output request	A freeze output command was given, but the motor remains stopped until a run permissive signal is received.
Freeze ref.	<i>Freeze Reference</i> was chosen as a function for a digital input (parameter group <i>5-1* Digital Inputs</i>). The corresponding terminal is active. The frequency converter saves the actual reference. Changing the reference is now only possible via terminal functions Speed Up and Speed Down.
Jog request	A jog command was given, but the motor remains stopped until a run permissive signal is received via a digital input.

Jogging	The motor is running as programmed in <i>3-19 Jog Speed [RPM]</i> . <ul style="list-style-type: none"> <i>Jog</i> was selected as function for a digital input (parameter group <i>5-1* Digital Inputs</i>). The corresponding terminal (e.g. Terminal 29) is active. The Jog function is activated via the serial communication. The Jog function was selected as a reaction for a monitoring function (e.g. No signal). The monitoring function is active.
Motor check	In <i>1-80 Function at Stop, Motor Check</i> was selected. A stop command is active. To ensure that a motor is connected to the frequency converter, a permanent test current is applied to the motor.
OVC control	<i>Overvoltage</i> control was activated in <i>2-17 Overvoltage Control, [2] Enabled</i> . The connected motor is supplying the frequency converter with generative energy. The overvoltage control adjusts the V/Hz ratio to run the motor in controlled mode and to prevent the frequency converter from tripping.
PowerUnit Off	(Only frequency converters with an external 24 V power supply installed). Mains supply to the frequency converter was removed, and the control card is supplied by the external 24 V.
Protection md	Protection mode is active. The unit has detected a critical status (overcurrent or overvoltage). <ul style="list-style-type: none"> To avoid tripping, switching frequency is reduced to 4 kHz. If possible, protection mode ends after approximately 10 s Protection mode can be restricted in <i>14-26 Trip Delay at Inverter Fault</i>
QStop	The motor is decelerating using <i>3-81 Quick Stop Ramp Time</i> . <ul style="list-style-type: none"> <i>Quick stop inverse</i> was chosen as a function for a digital input (parameter group <i>5-1* Digital Inputs</i>). The corresponding terminal is not active. The quick stop function was activated via serial communication.
Ramping	The motor is accelerating/decelerating using the active Ramp Up/Down. The reference, a limit value, or a standstill is not yet reached.
Ref. high	The sum of all active references is above the reference limit set in <i>4-55 Warning Reference High</i> .
Ref. low	The sum of all active references is below the reference limit set in <i>4-54 Warning Reference Low</i> .

Run on ref.	The frequency converter is running in the reference range. The feedback value matches the setpoint value.
Run request	A start command was given, but the motor remains stopped until a run permissive signal is received via digital input.
Running	The motor is driven by the frequency converter.
Sleep Mode	The energy-saving function is enabled. The motor has stopped, but restarts automatically when required.
Speed high	Motor speed is above the value set in <i>4-53 Warning Speed High</i> .
Speed low	Motor speed is below the value set in <i>4-52 Warning Speed Low</i> .
Standby	In Auto On mode, the frequency converter starts the motor with a start signal from a digital input or serial communication.
Start delay	In <i>1-71 Start Delay</i> , a delay starting time was set. A start command is activated and the motor starts after the start delay time expires.
Start fwd/rev	Start forward and start reverse were selected as functions for 2 different digital inputs (parameter group <i>5-1* Digital Inputs</i>). The motor starts in forward or reverse depending on which corresponding terminal is activated.
Stop	The frequency converter has received a stop command from the LCP, digital input, or serial communication.
Trip	An alarm occurred and the motor is stopped. Once the cause of the alarm is cleared, the frequency converter can be reset manually by pressing [Reset] or remotely by control terminals or serial communication.
Trip lock	An alarm occurred and the motor is stopped. Once the cause of the alarm is cleared, power must be cycled to the frequency converter. The frequency converter can then be reset manually by pressing [Reset] or remotely by control terminals or serial communication.

Table 7.4 Operation Status

NOTICE

In auto/remote mode, the frequency converter requires external commands to execute functions.

7.3 Warning and Alarm Types

Warnings

A warning is issued when an alarm condition is impending or when an abnormal operating condition is present and may result in the frequency converter issuing an alarm. A warning clears by itself when the abnormal condition is removed.

Alarms

Trip

An alarm is issued when the frequency converter is tripped, which means that the frequency converter suspends operation to prevent frequency converter or system damage. The motor coasts to a stop. The frequency converter logic continues to operate and monitor the frequency converter status. After the fault condition is remedied, the frequency converter can be reset. It is then ready to start operation again.

Resetting the frequency converter after trip/trip lock

A trip can be reset in any of 4 ways:

- Press [Reset] on the LCP
- Digital reset input command
- Serial communication reset input command
- Auto reset

Trip lock

Input power is cycled. The motor coasts to a stop. The frequency converter continues to monitor the frequency converter status. Remove input power to the frequency converter, correct the cause of the fault, and reset the frequency converter.

Warning and Alarm Displays

- A warning is displayed in the LCP along with the warning number.
- An alarm flashes along with the alarm number.

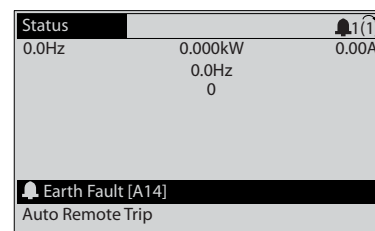
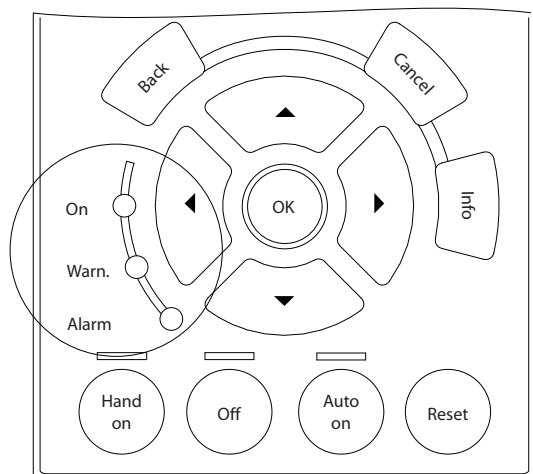

Illustration 7.2 Alarm Display Example

In addition to the text and alarm code on the LCP of the frequency converter, there are 3 status indicator lights.



1308B467.10

Illustration 7.3 Status Indicator Lights

	Warning LED	Alarm LED
Warning	On	Off
Alarm	Off	On (Flashing)
Trip-Lock	On	On (Flashing)

Table 7.5 Status Indicator Lights Explanations

7.4 List of Warnings and Alarms

The warning/alarm information below defines each warning/alarm condition, provides the probable cause for the condition, and details a remedy or troubleshooting procedure.

WARNING 1, 10 Volts low

The control card voltage is below 10 V from terminal 50. Remove some of the load from terminal 50, as the 10 V supply is overloaded. Max. 15 mA or minimum 590 Ω.

A short circuit in a connected potentiometer or improper wiring of the potentiometer can cause this condition.

Troubleshooting

Remove the wiring from terminal 50. If the warning clears, the problem is with the wiring. If the warning does not clear, replace the control card.

WARNING/ALARM 2, Live zero error

This warning or alarm only appears if programmed in *6-01 Live Zero Timeout Function*. The signal on one of the analog inputs is less than 50% of the minimum value programmed for that input. Broken wiring or faulty device sending the signal can cause this condition.

Troubleshooting

Check connections on all the analog input terminals. Control card terminals 53 and 54 for signals, terminal 55 common. MCB 101 terminals 11 and 12 for signals, terminal 10 common. MCB

109 terminals 1, 3, 5 for signals, terminals 2, 4, 6 common).

Check that the frequency converter programming and switch settings match the analog signal type.

Perform Input Terminal Signal Test.

WARNING/ALARM 3, No motor

No motor has been connected to the output of the frequency converter.

WARNING/ALARM 4, Mains phase loss

A phase is missing on the supply side, or the mains voltage imbalance is too high. This message also appears for a fault in the input rectifier on the frequency converter. Options are programmed at *14-12 Function at Mains Imbalance*.

Troubleshooting

Check the supply voltage and supply currents to the frequency converter.

WARNING 5, DC link voltage high

The intermediate circuit voltage (DC) is higher than the high-voltage warning limit. The limit is dependent on the frequency converter voltage rating. The unit is still active.

WARNING 6, DC link voltage low

The intermediate circuit voltage (DC) is lower than the low-voltage warning limit. The limit is dependent on the frequency converter voltage rating. The unit is still active.

WARNING/ALARM 7, DC overvoltage

If the intermediate circuit voltage exceeds the limit, the frequency converter trips after a time.

Troubleshooting

Connect a brake resistor

Extend the ramp time

Change the ramp type

Activate the functions in *2-10 Brake Function*

Increase *14-26 Trip Delay at Inverter Fault*

If the alarm/warning occurs during a power sag, use kinetic back-up (*14-10 Mains Failure*)

WARNING/ALARM 8, DC under voltage

If the intermediate circuit voltage (DC link) drops below the under voltage limit, the frequency converter checks if a 24 V DC back-up supply is connected. If no 24 V DC back-up supply is connected, the frequency converter trips after a fixed time delay. The time delay varies with unit size.

Troubleshooting

Check that the supply voltage matches the frequency converter voltage.

Perform input voltage test.

Perform soft charge circuit test.

WARNING/ALARM 9, Inverter overload

The frequency converter is about to cut out because of an overload (too high current for too long). The counter for electronic, thermal inverter protection issues a warning at 98% and trips at 100%, while giving an alarm. The frequency converter *cannot* be reset until the counter is below 90%.

The fault is that the frequency converter has run with more than 100% overload for too long.

Troubleshooting

Compare the output current shown on the LCP with the frequency converter rated current.

Compare the output current shown on the LCP with measured motor current.

Display the Thermal Drive Load on the LCP and monitor the value. When running above the frequency converter continuous current rating, the counter increases. When running below the frequency converter continuous current rating, the counter decreases.

WARNING/ALARM 10, Motor overload temperature

According to the electronic thermal protection (ETR), the motor is too hot. Select whether the frequency converter issues a warning or an alarm when the counter reaches 100% in *1-90 Motor Thermal Protection*. The fault occurs when the motor runs with more than 100% overload for too long.

Troubleshooting

Check for motor overheating.

Check if the motor is mechanically overloaded

Check that the motor current set in *1-24 Motor Current* is correct.

Ensure that Motor data in parameters 1-20 to 1-25 are set correctly.

If an external fan is in use, check in *1-91 Motor External Fan* that it is selected.

Running AMA in *1-29 Automatic Motor Adaptation (AMA)* tunes the frequency converter to the motor more accurately and reduces thermal loading.

WARNING/ALARM 11, Motor thermistor over temp

Check whether the thermistor is disconnected. Select whether the frequency converter issues a warning or an alarm in *1-90 Motor Thermal Protection*.

Troubleshooting

Check for motor overheating.

Check if the motor is mechanically overloaded.

When using terminal 53 or 54, check that the thermistor is connected correctly between either terminal 53 or 54 (analog voltage input) and terminal 50 (+10 V supply). Also check that the

terminal switch for 53 or 54 is set for voltage.

Check *1-93 Thermistor Source* selects terminal 53 or 54.

When using digital inputs 18 or 19, check that the thermistor is connected correctly between either terminal 18 or 19 (digital input PNP only) and terminal 50. Check *1-93 Thermistor Source* selects terminal 18 or 19.

WARNING/ALARM 12, Torque limit

The torque has exceeded the value in *4-16 Torque Limit Motor Mode* or the value in *4-17 Torque Limit Generator Mode*. *14-25 Trip Delay at Torque Limit* can change this warning from a warning-only condition to a warning followed by an alarm.

Troubleshooting

If the motor torque limit is exceeded during ramp up, extend the ramp up time.

If the generator torque limit is exceeded during ramp down, extend the ramp down time.

If torque limit occurs while running, possibly increase the torque limit. Make sure that the system can operate safely at a higher torque.

Check the application for excessive current draw on the motor.

WARNING/ALARM 13, Over current

The inverter peak current limit (approximately 200% of the rated current) is exceeded. The warning lasts about 1.5 s, then the frequency converter trips and issues an alarm. Shock loading or quick acceleration with high inertia loads can cause this fault. It can also appear after kinetic back-up, if the acceleration during ramp up is quick. If extended mechanical brake control is selected, trip can be reset externally.

Troubleshooting

Remove power and check if the motor shaft can be turned.

Check that the motor size matches the frequency converter.

Check parameters 1-20 to 1-25 for correct motor data.

ALARM 14, Earth (ground) fault

There is current from the output phases to earth, either in the cable between the frequency converter and the motor or in the motor itself.

Troubleshooting

Remove power to the frequency converter and repair the earth fault.

Check for earth faults in the motor by measuring the resistance to ground of the motor leads and the motor with a megohmmeter.

ALARM 15, Hardware mismatch

A fitted option is not operational with the present control board hardware or software.

Record the value of the following parameters and contact your Danfoss supplier:

15-40 FC Type

15-41 Power Section

15-42 Voltage

15-43 Software Version

15-45 Actual Typecode String

15-49 SW ID Control Card

15-50 SW ID Power Card

15-60 Option Mounted

15-61 Option SW Version (for each option slot)

ALARM 16, Short circuit

There is short-circuiting in the motor or motor wiring.

Remove power to the frequency converter and repair the short circuit.

WARNING/ALARM 17, Control word timeout

There is no communication to the frequency converter.

The warning is only active when *8-04 Control Word Timeout Function* is NOT set to [0] Off.

If *8-04 Control Word Timeout Function* is set to [5] Stop and Trip, a warning appears and the frequency converter ramps down until it stops then displays an alarm.

Troubleshooting

Check connections on the serial communication cable.

Increase *8-03 Control Word Timeout Time*

Check the operation of the communication equipment.

Verify a proper installation based on EMC requirements.

WARNING/ALARM 20, Temp. input error

The temperature sensor is not connected.

WARNING/ALARM 21, Parameter error

The parameter is out of range. The parameter number is reported in the LCP. The affected parameter must be set to a valid value.

WARNING/ALARM 22, Hoist mechanical brake

Report value shows what kind it is.

0 = The torque ref. was not reached before time-out (Parameter 2-27).

1 = Expected brake feedback not received before time-out (Parameters 2-23, 2-25).

WARNING 23, Internal fan fault

The fan warning function is an extra protective function that checks if the fan is running/mounted. The fan warning can be disabled in *14-53 Fan Monitor ([0] Disabled)*.

For the D, E, and F Frame filters, the regulated voltage to the fans is monitored.

Troubleshooting

Check for proper fan operation.

Cycle power to the frequency converter and check that the fan operates briefly at start-up.

Check the sensors on the heatsink and control card.

WARNING 24, External fan fault

The fan warning function is an extra protective function that checks if the fan is running/mounted. The fan warning can be disabled in *14-53 Fan Monitor ([0] Disabled)*.

Troubleshooting

Check for proper fan operation.

Cycle power to the frequency converter and check that the fan operates briefly at start-up.

Check the sensors on the heatsink and control card.

WARNING 25, Brake resistor short circuit

The brake resistor is monitored during operation. If a short circuit occurs, the brake function is disabled and the warning appears. The frequency converter is still operational but without the brake function. Remove power to the frequency converter and replace the brake resistor (see *2-15 Brake Check*).

WARNING/ALARM 26, Brake resistor power limit

The power transmitted to the brake resistor is calculated as a mean value over the last 120 seconds of run time. The calculation is based on the intermediate circuit voltage and the brake resistance value set in *2-16 AC brake Max. Current*. The warning is active when the dissipated braking power is higher than 90% of the brake resistance power. If [2] Trip is selected in *2-13 Brake Power Monitoring*, the frequency converter trips when the dissipated braking power reaches 100%.

WARNING/ALARM 27, Brake chopper fault

The brake transistor is monitored during operation and if a short circuit occurs, the brake function is disabled and a warning is issued. The frequency converter is still operational but, since the brake transistor has short-circuited, substantial power is transmitted to the brake resistor, even if it is inactive.

Remove power to the frequency converter and remove the brake resistor.

WARNING/ALARM 28, Brake check failed

The brake resistor is not connected or not working. Check *2-15 Brake Check*.

ALARM 29, Heatsink temp

The maximum temperature of the heatsink has been exceeded. The temperature fault will not reset until the temperature falls below a defined heatsink temperature. The trip and reset points are different based on the frequency converter power size.

Troubleshooting

Check for the following conditions.

- Ambient temperature too high.
- Motor cable too long.
- Incorrect airflow clearance above and below the frequency converter.
- Blocked airflow around the frequency converter.
- Damaged heatsink fan.
- Dirty heatsink.

ALARM 30, Motor phase U missing

Motor phase U between the frequency converter and the motor is missing.

Remove power from the frequency converter and check motor phase U.

ALARM 31, Motor phase V missing

Motor phase V between the frequency converter and the motor is missing.

Remove power from the frequency converter and check motor phase V.

ALARM 32, Motor phase W missing

Motor phase W between the frequency converter and the motor is missing.

Remove power from the frequency converter and check motor phase W.

ALARM 33, Inrush fault

Too many power-ups have occurred within a short time period. Let the unit cool to operating temperature.

WARNING/ALARM 34, Fieldbus communication fault

The fieldbus on the communication option card is not working.

WARNING/ALARM 35, Option fault

An option alarm is received. The alarm is option-specific. The most likely cause is a power-up or a communication fault.

WARNING/ALARM 36, Mains failure

This warning/alarm is only active if the supply voltage to the frequency converter is lost and *14-10 Mains Failure* is NOT set to [0] *No Function*. Check the fuses to the frequency converter and mains supply to the unit.

ALARM 37, Phase imbalance

There is a current imbalance between the power units

ALARM 38, Internal fault

When an internal fault occurs, a code number defined in *Table 7.6* is displayed.

Troubleshooting

- Cycle power
- Check that the option is properly installed
- Check for loose or missing wiring

It may be necessary to contact your Danfoss supplier or service department. Note the code number for further troubleshooting directions.

No.	Text
0	Serial port cannot be initialised. Contact your Danfoss supplier or Danfoss Service Department.
256-258	Power EEPROM data is defective or too old
512	Control board EEPROM data is defective or too old.
513	Communication time-out reading EEPROM data
514	Communication time-out reading EEPROM data
515	Application-oriented control cannot recognise the EEPROM data.
516	Cannot write to the EEPROM because a write command is on progress.
517	Write command is under time-out
518	Failure in the EEPROM
519	Missing or invalid barcode data in EEPROM
783	Parameter value outside of min/max limits
1024-1279	A CAN telegram that has to be sent could not be sent.
1281	Digital signal processor flash timeout
1282	Power micro software version mismatch
1283	Power EEPROM data version mismatch
1284	Cannot read digital signal processor software version
1299	Option SW in slot A is too old
1300	Option SW in slot B is too old
1301	Option SW in slot C0 is too old
1302	Option SW in slot C1 is too old
1315	Option SW in slot A is not supported (not allowed)
1316	Option SW in slot B is not supported (not allowed)
1317	Option SW in slot C0 is not supported (not allowed)
1318	Option SW in slot C1 is not supported (not allowed)
1379	Option A did not respond when calculating platform version
1380	Option B did not respond when calculating platform version
1381	Option C0 did not respond when calculating platform version.
1382	Option C1 did not respond when calculating platform version.
1536	An exception in the application-oriented control is registered. Debug information written in LCP.
1792	HW reset of DSP
1793	Motor derived parameters not transferred correctly to DSP
1794	Power data not transferred correctly at power up to DSP
1795	The DSP has received too many unknown SPI telegrams
1796	RAM copy error



No.	Text
2049	Power data restarted
2064-2072	H081x: Option in slot x has restarted
2080-2088	H082x: Option in slot x has issued a powerup-wait
2096-2104	H983x: Option in slot x has issued a legal powerup-wait
2304	Could not read any data from power EEPROM
2305	Missing SW version from power unit
2314	Missing power unit data from power unit
2315	Missing SW version from power unit
2316	Missing lo_statepage from power unit
2324	Power card configuration is determined to be incorrect at power up
2325	A power card has stopped communicating while main power is applied
2326	Power card configuration is determined to be incorrect after the delay for power cards to register.
2327	Too many power card locations have been registered as present.
2330	Power size information between the power cards does not match.
2561	No communication from DSP to ATACD
2562	No communication from ATACD to DSP (state running)
2816	Stack overflow control board module
2817	Scheduler slow tasks
2818	Fast tasks
2819	Parameter thread
2820	LCP stack overflow
2821	Serial port overflow
2822	USB port overflow
2836	cfListMempool too small
3072-5122	Parameter value is outside its limits
5123	Option in slot A: Hardware incompatible with control board hardware
5124	Option in slot B: Hardware incompatible with control board hardware.
5125	Option in slot C0: Hardware incompatible with control board hardware.
5126	Option in slot C1: Hardware incompatible with control board hardware.
5376-6231	Out of memory

Table 7.6 Internal Fault, Code Numbers

ALARM 39, Heatsink sensor

No feedback from the heatsink temperature sensor.

The signal from the IGBT thermal sensor is not available on the power card. The problem could be on the power card, on the gate drive card, or the ribbon cable between the power card and gate drive card.

WARNING 40, Overload of digital output terminal 27

Check the load connected to terminal 27 or remove short-circuit connection. Check *5-00 Digital I/O Mode* and *5-01 Terminal 27 Mode*.

WARNING 41, Overload of digital output terminal 29

Check the load connected to terminal 29 or remove short-circuit connection. Check *5-00 Digital I/O Mode* and *5-02 Terminal 29 Mode*.

WARNING 42, Overload of digital output on X30/6 or overload of digital output on X30/7

For X30/6, check the load connected to X30/6 or remove the short-circuit connection. Check *5-32 Term X30/6 Digi Out (MCB 101)*.

For X30/7, check the load connected to X30/7 or remove the short-circuit connection. Check *5-33 Term X30/7 Digi Out (MCB 101)*.

ALARM 43, Ext. supply

MCB 113 Ext. Relay Option is mounted without ext. 24V DC. Either connect an ext. 24V DC supply or specify that no external supply is used via *14-80 Option Supplied by External 24VDC [0]*. A change in *14-80 Option Supplied by External 24VDC* requires a power cycle.

ALARM 45, Earth fault 2

Earth (ground) fault.

Troubleshooting

Check for proper earthing (grounding) and loose connections.

Check for proper wire size.

Check motor cables for short-circuits or leakage currents.

ALARM 46, Power card supply

The supply on the power card is out of range.

There are three power supplies generated by the switch mode power supply (SMPS) on the power card: 24 V, 5 V, ±18 V. When powered with 24 V DC with the MCB 107 option, only the 24 V and 5 V supplies are monitored. When powered with three phase mains voltage, all three supplies are monitored.

Troubleshooting

Check for a defective power card.

Check for a defective control card.

Check for a defective option card.

If a 24 V DC power supply is used, verify proper supply power.

WARNING 47, 24 V supply low

The 24 V DC is measured on the control card. The external 24 V DC back-up power supply may be overloaded, otherwise contact the Danfoss supplier.

WARNING 48, 1.8 V supply low

The 1.8 V DC supply used on the control card is outside of allowable limits. The power supply is measured on the control card. Check for a defective control card. If an option card is present, check for an overvoltage condition.

WARNING 49, Speed limit

When the speed is not within the specified range in *4-11 Motor Speed Low Limit [RPM]* and *4-13 Motor Speed High Limit [RPM]*, the frequency converter shows a warning. When the speed is below the specified limit in *1-86 Trip Speed Low [RPM]* (except when starting or stopping), the frequency converter trips.

ALARM 50, AMA calibration failed

Contact your Danfoss supplier or Danfoss Service Department.

ALARM 51, AMA check U_{nom} and I_{nom}

The settings for motor voltage, motor current and motor power are wrong. Check the settings in parameters 1-20 to 1-25.

ALARM 52, AMA low I_{nom}

The motor current is too low. Check the settings.

ALARM 53, AMA motor too big

The motor is too big for the AMA to operate.

ALARM 54, AMA motor too small

The motor is too small for the AMA to operate.

ALARM 55, AMA parameter out of range

The parameter values of the motor are outside of the acceptable range. AMA cannot run.

ALARM 56, AMA interrupted by user

The user has interrupted the AMA.

ALARM 57, AMA internal fault

Try to restart AMA again. Repeated restarts can over heat the motor.

ALARM 58, AMA Internal fault

Contact your Danfoss supplier.

WARNING 59, Current limit

The current is higher than the value in *4-18 Current Limit*. Ensure that Motor data in parameters 1-20 to 1-25 are set correctly. Possibly increase the current limit. Be sure that the system can operate safely at a higher limit.

WARNING 60, External interlock

A digital input signal is indicating a fault condition external to the frequency converter. An external interlock has commanded the frequency converter to trip. Clear the external fault condition. To resume normal operation, apply 24 V DC to the terminal programmed for external interlock. Reset the frequency converter.

WARNING/ALARM 61, Feedback error

An error between calculated speed and speed measurement from feedback device. The function Warning/Alarm/Disabling setting is in *4-30 Motor Feedback Loss Function*. Accepted error setting in *4-31 Motor Feedback*

Speed Error and the allowed time the error occur setting in *4-32 Motor Feedback Loss Timeout*. During a commissioning procedure the function may be effective.

WARNING 62, Output frequency at maximum limit

The output frequency has reached the value set in *4-19 Max Output Frequency*. Check the application to determine the cause. Possibly increase the output frequency limit. Be sure the system can operate safely at a higher output frequency. The warning will clear when the output drops below the maximum limit.

ALARM 63, Mechanical brake low

The actual motor current has not exceeded the "release brake" current within the "Start delay" time window.

ALARM 64, Voltage Limit

The load and speed combination demands a motor voltage higher than the actual DC link voltage.

WARNING/ALARM 65, Control card over temperature

The cut-out temperature of the control card is 80 °C.

Troubleshooting

- Check that the ambient operating temperature is within limits
- Check for clogged filters
- Check fan operation
- Check the control card

WARNING 66, Heatsink temperature low

The frequency converter is too cold to operate. This warning is based on the temperature sensor in the IGBT module.

Increase the ambient temperature of the unit. Also, a trickle amount of current can be supplied to the frequency converter whenever the motor is stopped by setting *2-00 DC Hold/Preheat Current* at 5% and *1-80 Function at Stop*

ALARM 67, Option module configuration has changed

One or more options have either been added or removed since the last power-down. Check that the configuration change is intentional and reset the unit.

ALARM 68, Safe Stop activated

Safe stop has been activated. To resume normal operation, apply 24 V DC to terminal 37, then send a reset signal (via Bus, Digital I/O, or by pressing the reset key).

ALARM 69, Power card temperature

The temperature sensor on the power card is either too hot or too cold.

Troubleshooting

- Check that the ambient operating temperature is within limits.
- Check for clogged filters.
- Check fan operation.
- Check the power card.

ALARM 70, Illegal FC configuration

The control card and power card are incompatible. To check compatibility, contact your supplier with the type code of the unit from the nameplate and the part numbers of the cards.

ALARM 71, PTC 1 safe stop

Safe Stop has been activated from the MCB 112 PTC Thermistor Card (motor too warm). Normal operation can be resumed when the MCB 112 applies 24 V DC to T-37 again (when the motor temperature reaches an acceptable level) and when the Digital Input from the MCB 112 is deactivated. When that happens, a reset signal must be sent (via Bus, Digital I/O, or by pressing [Reset]).

ALARM 72, Dangerous failure

Safe Stop with trip lock. An unexpected combination of safe stop commands has occurred:

- MCB 112 VLT PTC Thermistor Card enables X44/10, but safe stop is not enabled.
- MCB 112 is the only device using safe stop (specified through selection [4] or [5] in *5-19 Terminal 37 Safe Stop*), safe stop is activated, and X44/10 is not activated.

WARNING 73, Safe stop auto restart

Safe stopped. With automatic restart enabled, the motor may start when the fault is cleared.

ALARM 74, PTC Thermistor

Alarm related to the ATEX option. The PTC is not working.

ALARM 75, Illegal profile sel.

Parameter value must not be written while motor is running. Stop motor before writing MCO profile to *8-10 Control Word Profile* for instance.

WARNING 76, Power unit setup

The required number of power units does not match the detected number of active power units.

WARNING 77, Reduced power mode

The frequency converter is operating in reduced power mode (i.e. less than the allowed number of inverter sections). This warning is generated on power cycle when the frequency converter is set to run with fewer inverters, and remains on.

ALARM 78, Tracking error

The difference between set point value and actual value has exceeded the value in *4-35 Tracking Error*. Disable the function by *4-34 Tracking Error Function* or select an alarm/warning also in *4-34 Tracking Error Function*. Investigate the mechanics around the load and motor, check feedback connections from motor – encoder – to frequency converter. Select motor feedback function in *4-30 Motor Feedback Loss Function*. Adjust tracking error band in *4-35 Tracking Error* and *4-37 Tracking Error Ramping*.

ALARM 79, Illegal power section configuration

The scaling card has an incorrect part number or is not installed. The MK102 connector on the power card could not be installed.

ALARM 80, Drive initialised to default value

Parameter settings are initialised to default settings after a manual reset. To clear the alarm, reset the unit.

ALARM 81, CSIV corrupt

CSIV file has syntax errors.

ALARM 82, CSIV parameter error

CSIV failed to init a parameter.

ALARM 83, Illegal option combination

The mounted options are incompatible.

ALARM 84, No safety option

The safety option was removed without applying a general reset. Reconnect the safety option.

ALARM 85, Dang fail PB:

Profibus/Profisafe Error.

ALARM 88, Option detection

A change in the option layout was detected. *14-89 Option Detection* is set to [0] *Frozen configuration* and the option layout has been changed.

- To apply the change, enable option layout changes in *14-89 Option Detection*.
- Alternatively, restore the correct option configuration.

WARNING 89, Mechanical brake sliding

The hoist brake monitor has detected a motor speed > 10 RPM.

ALARM 90, Feedback monitor

Check the connection to encoder/resolver option and eventually replace the MCB 102 or MCB 103.

ALARM 91, Analog input 54 wrong settings

Switch S202 has to be set in position OFF (voltage input) when a KTY sensor is connected to analog input terminal 54.

ALARM 99, Blocked rotor

Rotor is Blocked.

WARNING/ALARM 104, Mixing fan fault

The fan is not operating. The fan monitor checks that the fan is spinning at power-up or whenever the mixing fan is turned on. The mixing-fan fault can be configured as a warning or an alarm trip by *14-53 Fan Monitor*.

Troubleshooting

Cycle power to the frequency converter to determine if the warning/alarm returns.

WARNING/ALARM 122, Mot. rotat. unexp.

The motor is rotating unexpectedly. The frequency converter is performing a function that requires the motor to be at standstill, for example, DC hold for PM motors.

WARNING 163, ATEX ETR cur.lim.warning

The frequency converter has exceeded the characteristic curve for more than 50 s. The warning is activated at 83% and de-activated at 65% of the permitted thermal overload.

ALARM 164, ATEX ETR cur.lim.alarm

Operating above the characteristic curve for more than 60 s within a period of 600 s activates the alarm and the frequency converter trips.

WARNING 165, ATEX ETR freq.lim.warning

The frequency converter is running more than 50 s below the permitted minimum frequency (*1-98 ATEX ETR interpol. points freq. [0]*).

ALARM 166, ATEX ETR freq.lim.alarm

The frequency converter has operated more than 60 s (in a period of 600 s) below the permitted minimum frequency (*1-98 ATEX ETR interpol. points freq. [0]*).

ALARM 246, Power card supply

This alarm is only for F Frame frequency converters. It is equivalent to Alarm 46. The report value in the alarm log indicates which power module generated the alarm:

- 1 = left most inverter module.
- 2 = middle inverter module in F2 or F4 frequency converter.
- 2 = right inverter module in F1 or F3 frequency converter.
- 3 = right inverter module in F2 or F4 frequency converter.
- 5 = rectifier module.

WARNING 250, New spare part

A component in the frequency converter has been replaced. Reset the frequency converter for normal operation.

WARNING 251, New typecode

The power card or other components have been replaced and the typecode changed. Reset to remove the warning and resume normal operation.

7.5 Troubleshooting

Symptom	Possible Cause	Test	Solution
Display dark/No function	Missing input power	See <i>Table 4.5</i> .	Check the input power source.
	Missing or open fuses or circuit breaker tripped	See open fuses and tripped circuit breaker in this table for possible causes.	Follow the recommendations provided.
	No power to the LCP	Check the LCP cable for proper connection or damage.	Replace the faulty LCP or connection cable.
	Shortcut on control voltage (terminal 12 or 50) or at control terminals	Check the 24 V control voltage supply for terminal 12/13 to 20-39 or 10 V supply for terminal 50 to 55.	Wire the terminals properly.
	Wrong LCP (LCP from VLT® 2800 or 5000/6000/8000/ FCD or FCM)		Use only LCP 101 (P/N 130B1124) or LCP 102 (P/N. 130B1107).
	Wrong contrast setting		Press [Status] + ▲/▼ to adjust the contrast.
	Display (LCP) is defective	Test using a different LCP.	Replace the faulty LCP or connection cable.
	Internal voltage supply fault or SMPS is defective		Contact supplier.
Intermittent display	Overloaded power supply (SMPS) due to improper control wiring or a fault within the frequency converter	To rule out a problem in the control wiring, disconnect all control wiring by removing the terminal blocks.	If the display stays lit, then the problem is in the control wiring. Check the wiring for shorts or incorrect connections. If the display continues to cut out, follow the procedure for display dark.
Motor not running	Service switch open or missing motor connection	Check if the motor is connected and the connection is not interrupted (by a service switch or other device).	Connect the motor and check the service switch.
	No mains power with 24 V DC option card	If the display is functioning but no output, check that mains power is applied to the frequency converter.	Apply mains power to run the unit.
	LCP Stop	Check if [Off] has been pressed.	Press [Auto On] or [Hand On] (depending on your operation mode) to run the motor.
	Missing start signal (Standby)	Check <i>5-10 Terminal 18 Digital Input</i> for correct setting for terminal 18 (use default setting).	Apply a valid start signal to start the motor.
	Motor coast signal active (Coasting)	Check <i>5-12 Terminal 27 Digital Input</i> for correct setting for terminal 27 (use default setting).	Apply 24 V on terminal 27 or program this terminal to <i>No operation</i> .
	Wrong reference signal source	Check reference signal: Local, remote or bus reference? Preset reference active? Terminal connection correct? Scaling of terminals correct? Reference signal available?	Program correct settings Check <i>3-13 Reference Site</i> Set preset reference active in parameter group <i>3-1* References</i> . Check for correct wiring. Check scaling of terminals. Check reference signal.
Motor running in wrong direction	Motor rotation limit	Check that <i>4-10 Motor Speed Direction</i> is programmed correctly.	Program correct settings.
	Active reversing signal	Check if a reversing command is programmed for the terminal in parameter group <i>5-1* Digital inputs</i> .	Deactivate reversing signal.
	Wrong motor phase connection		See <i>5.5 Checking Motor Rotation</i> in this manual.

Symptom	Possible Cause	Test	Solution
Motor is not reaching maximum speed	Frequency limits set wrong	Check output limits in 4-13 <i>Motor Speed High Limit [RPM]</i> , 4-14 <i>Motor Speed High Limit [Hz]</i> , and 4-19 <i>Max Output Frequency</i>	Program correct limits.
	Reference input signal not scaled correctly	Check reference input signal scaling in parameter group 6-0* <i>Analog I/O mode</i> and parameter group 3-1* <i>References</i> .	Program correct settings.
Motor speed unstable	Possible incorrect parameter settings	Check the settings of all motor parameters, including all motor compensation settings. For closed loop operation, check PID settings.	Check settings in parameter group 1-6* <i>Load-Depend.Setta</i> . For closed loop operation check settings in parameter group 20-0* <i>Feedback</i> .
Motor runs rough	Possible over-magnetization	Check for incorrect motor settings in all motor parameters.	Check motor settings in parameter groups 1-2* <i>Motor data</i> 1-3* <i>Adv Motor Data</i> , and 1-5* <i>Load Indep. Setting</i> .
Motor will not brake	Possible incorrect settings in the brake parameters. Possible too short ramp down times.	Check brake parameters. Check ramp time settings.	Check parameter group 2-0* <i>DC Brake</i> and 3-0* <i>Reference Limits</i> .
Open power fuses or circuit breaker trip	Phase to phase short	Motor or panel has a short phase to phase. Check motor and panel phase to for shorts.	Eliminate any shorts detected.
	Motor overload	Motor is overloaded for the application.	Perform startup test and verify motor current is within specifications. If motor current is exceeding nameplate full load current, motor may run only with reduced load. Review the specifications for the application.
	Loose connections	Perform pre-startup check for loose connections.	Tighten loose connections.
Mains current imbalance greater than 3%	Problem with mains power (See <i>Alarm 4 Mains phase loss</i> description)	Rotate input power leads into the drive one position: A to B, B to C, C to A.	If imbalanced leg follows the wire, it is a power problem. Check mains power supply.
	Problem with the frequency converter unit	Rotate input power leads into the frequency converter one position: A to B, B to C, C to A.	If imbalance leg stays on same input terminal, it is a problem with the unit. Contact supplier.
Motor current imbalance greater than 3%	Problem with motor or motor wiring	Rotate output motor leads one position: U to V, V to W, W to U.	If imbalanced leg follows the wire, the problem is in the motor or motor wiring. Check motor and motor wiring.
	Problem with frequency converter unit	Rotate output motor leads one position: U to V, V to W, W to U.	If imbalance leg stays on same output terminal, it is a problem with the unit. Contact supplier.
Frequency converter acceleration problems	Motor data are entered incorrectly	If warnings or alarms occur, see Check that motor data are entered correctly	Increase the ramp-up time in 3-41 <i>Ramp 1 Ramp Up Time</i> . Increase current limit in 4-18 <i>Current Limit</i> . Increase torque limit in 4-16 <i>Torque Limit Motor Mode</i> .
Frequency converter deceleration problems	Motor data are entered incorrectly	If warnings or alarms occur, see Check that motor data are entered correctly	Increase the ramp-down time in 3-42 <i>Ramp 1 Ramp Down Time</i> . Enable overvoltage control in 2-17 <i>Over-voltage Control</i> .

Table 7.7 Troubleshooting

8 Specifications

8.1 Electrical Data

8.1.1 Mains Supply 3x200-240 V AC

Type Designation	PK25	PK37	PK55	PK75	P1K1	P1K5	P2K2	P3K0	P3K7
Typical Shaft Output [kW]	0.25	0.37	0.55	0.75	1.1	1.5	2.2	3.0	3.7
Enclosure IP20 (FC 301 only)	A1	A1	A1	A1	A1	A1	-	-	-
Enclosure IP20/IP21	A2	A2	A2	A2	A2	A2	A2	A3	A3
Enclosure IP55, IP66	A4/A5	A4/A5	A4/A5	A4/A5	A4/A5	A4/A5	A4/A5	A5	A5
Output current									
Continuous (3x200-240 V) [A]	1.8	2.4	3.5	4.6	6.6	7.5	10.6	12.5	16.7
Intermittent (3x200-240 V) [A]	2.9	3.8	5.6	7.4	10.6	12.0	17.0	20.0	26.7
Continuous kVA (208 V AC) [kVA]	0.65	0.86	1.26	1.66	2.38	2.70	3.82	4.50	6.00
Max. input current									
Continuous (3x200-240 V) [A]	1.6	2.2	3.2	4.1	5.9	6.8	9.5	11.3	15.0
Intermittent (3x200-240 V) [A]	2.6	3.5	5.1	6.6	9.4	10.9	15.2	18.1	24.0
Additional Specifications									
Max. cable cross section ⁴⁾ for mains, motor, brake and load sharing [mm ²] ([AWG])	4,4,4 (12,12,12) (min. 0.2 (24))								
Max. cable cross section ⁴⁾ for disconnect [mm ²] ([AWG])	6,4,4 (10,12,12)								
Estimated power loss at rated max. load [W] ³⁾	21	29	42	54	63	82	116	155	185
Efficiency ²⁾	0.94	0.94	0.95	0.95	0.96	0.96	0.96	0.96	0.96

Table 8.1 Mains Supply 3x200-240 V AC, PK25-P3K7

Type Designation	P5K5		P7K5		P11K	
	HO	NO	HO	NO	HO	NO
High/Normal Overload ¹⁾						
Typical Shaft Output [kW]	5.5	7.5	7.5	11	11	15
Enclosure IP20	B3		B3		B4	
Enclosure IP21, IP55, IP66	B1		B1		B2	
Output current						
Continuous (3x200-240 V) [A]	24.2	30.8	30.8	46.2	46.2	59.4
Intermittent (60 s overload) (3x200-240 V) [A]	38.7	33.9	49.3	50.8	73.9	65.3
Continuous kVA (208 V AC) [kVA]	8.7	11.1	11.1	16.6	16.6	21.4
Max. input current						
Continuous (3x200-240 V) [A]	22.0	28.0	28.0	42.0	42.0	54.0
Intermittent (60 s overload) (3x200-240 V) [A]	35.2	30.8	44.8	46.2	67.2	59.4
Additional Specifications						
IP20 max. cable cross-section ⁴⁾ for mains, brake, motor and load sharing [mm ²] ([AWG])	10,10,- (8,8,-)		10,10,- (8,8,-)		35,-,- (2,-,-)	
IP21 max. cable cross-section ⁴⁾ for mains, brake and load sharing [mm ²] ([AWG])	16,10,16 (6,8,6)		16,10,16 (6,8,6)		35,-,- (2,-,-)	
IP21 max. cable cross-section ⁴⁾ for motor [mm ²] ([AWG])	10,10,- (8,8,-)		10,10,- (8,8,-)		35,25,25 (2,4,4)	
Max. cable cross-section ⁴⁾ for Disconnect [mm ²] ([AWG])	16,10,10 (6,8,8)					
Estimated power loss at rated max. load [W] ³⁾	239	310	371	514	463	602
Efficiency ²⁾	0.96		0.96		0.96	

Table 8.2 Mains Supply 3x200-240 V AC, P5K5-P11K

Type Designation	P15K		P18K		P22K		P30K		P37K	
	HO	NO	HO	NO	HO	NO	HO	NO	HO	NO
High/Normal Overload ¹⁾										
Typical Shaft Output [kW]	15	18.5	18.5	22	22	30	30	37	37	45
Enclosure IP20	B4		C3		C3		C4		C4	
Enclosure IP21, IP55, IP66	C1		C1		C1		C2		C2	
Output current										
Continuous (3x200-240 V) [A]	59.4	74.8	74.8	88.0	88.0	115	115	143	143	170
Intermittent (60 s overload) (3x200-240 V) [A]	89.1	82.3	112	96.8	132	127	173	157	215	187
Continuous kVA (208 V AC) [kVA]	21.4	26.9	26.9	31.7	31.7	41.4	41.4	51.5	51.5	61.2
Max. input current										
Continuous (3x200-240 V) [A]	54.0	68.0	68.0	80.0	80.0	104	104	130	130	154
Intermittent (60 s overload) (3x200-240 V) [A]	81.0	74.8	102	88.0	120	114	156	143	195	169
Additional Specifications										
IP20 max. cable cross-section for mains, brake, motor and load sharing [mm ²] ([AWG])	35 (2)		50 (1)		50 (1)		150 (300MCM)		150 (300MCM)	
IP21, IP55, IP66 max. cable cross-section for mains and motor [mm ²] ([AWG])	50 (1)		50 (1)		50 (1)		150 (300MCM)		150 (300MCM)	
IP21, IP55, IP66 max. cable cross-section for brake and load sharing [mm ²] ([AWG])	50 (1)		50 (1)		50 (1)		95 (3/0)		95 (3/0)	
Max. cable cross-section ⁴⁾ for Disconnect [mm ²] ([AWG])	50, 35, 35 (1, 2, 2)						95, 70, 70 (3/0, 2/0, 2/0)		185, 150, 120 (350MCM, 300MCM, 4/0)	
Estimated power loss at rated max. load [W] ³⁾	624	737	740	845	874	1140	1143	1353	1400	1636
Efficiency ²⁾	0.96		0.97		0.97		0.97		0.97	

Table 8.3 Mains Supply 3x200-240 V AC, P15K-P37K

8.1.2 Mains Supply 3x380-500 V AC

Type Designation	PK37	PK55	PK75	P1K1	P1K5	P2K2	P3K0	P4K0	P5K5	P7K5
Typical Shaft Output [kW]	0.37	0.55	0,75	1.1	1.5	2.2	3.0	4.0	5.5	7.5
Enclosure IP20 (FC 301 only)	A1	A1	A1	A1	A1	-	-	-	-	-
Enclosure IP20/IP21	A2	A2	A2	A2	A2	A2	A2	A2	A3	A3
Enclosure IP55, IP66	A4/A5	A4/A5	A4/A5	A4/A5	A4/A5	A4/A5	A4/A5	A4/A5	A5	A5
Output current High overload 160% for 1 min										
Shaft output [kW]	0.37	0.55	0.75	1.1	1.5	2.2	3	4	5.5	7.5
Continuous (3x380-440 V) [A]	1.3	1.8	2.4	3.0	4.1	5.6	7.2	10	13	16
Intermittent (3x380-440 V) [A]	2.1	2.9	3.8	4.8	6.6	9.0	11.5	16	20.8	25.6
Continuous (3x441-500 V) [A]	1.2	1.6	2.1	2.7	3.4	4.8	6.3	8.2	11	14.5
Intermittent (3x441-500 V) [A]	1.9	2.6	3.4	4.3	5.4	7.7	10.1	13.1	17.6	23.2
Continuous kVA (400 V AC) [kVA]	0.9	1.3	1.7	2.1	2.8	3.9	5.0	6.9	9.0	11
Continuous kVA (460 V AC) [kVA]	0.9	1.3	1.7	2.4	2.7	3.8	5.0	6.5	8.8	11.6
Max. input current										
Continuous (3x380-440 V) [A]	1.2	1.6	2.2	2.7	3.7	5.0	6.5	9.0	11.7	14.4
Intermittent (3x380-440 V) [A]	1.9	2.6	3.5	4.3	5.9	8.0	10.4	14.4	18.7	23
Continuous (3x441-500 V) [A]	1.0	1.4	1.9	2.7	3.1	4.3	5.7	7.4	9.9	13
Intermittent (3x441-500 V) [A]	1.6	2.2	3.0	4.3	5.0	6.9	9.1	11.8	15.8	20.8
Additional Specifications										
IP20, IP21 max. cable cross-section ⁴⁾ for mains, motor, brake and load sharing [mm ²] ([AWG])	4,4,4 (12,12,12) (min. 0.2(24))									
IP55, IP66 max. cable cross-section ⁴⁾ for mains, motor, brake and load sharing [mm ²] ([AWG])	4,4,4 (12,12,12)									
Max. cable cross-section ⁴⁾ for disconnect [mm ²] ([AWG])	6,4,4 (10,12,12)									
Estimated power loss at rated max. load [W] ³⁾	35	42	46	58	62	88	116	124	187	255
Efficiency ²⁾	0.93	0.95	0.96	0.96	0.97	0.97	0.97	0.97	0.97	0.97

Table 8.4 Mains Supply 3x380-500 V AC (FC 302), 3x380-480 V AC (FC 301), PK37-P7K5

Type Designation	P11K		P15K		P18K		P22K	
High/Normal Overload ¹⁾	HO	NO	HO	NO	HO	NO	HO	NO
Typical Shaft output [kW]	11	15	15	18.5	18.5	22.0	22.0	30.0
Enclosure IP20	B3		B3		B4		B4	
Enclosure IP21	B1		B1		B2		B2	
Enclosure IP55, IP66	B1		B1		B2		B2	
Output current								
Continuous (3x380-440 V) [A]	24	32	32	37.5	37.5	44	44	61
Intermittent (60 s overload) (3x380-440 V) [A]	38.4	35.2	51.2	41.3	60	48.4	70.4	67.1
Continuous (3x441-500 V) [A]	21	27	27	34	34	40	40	52
Intermittent (60 s overload) (3x441-500 V) [A]	33.6	29.7	43.2	37.4	54.4	44	64	57.2
Continuous kVA (400 V AC) [kVA]	16.6	22.2	22.2	26	26	30.5	30.5	42.3
Continuous kVA (460 V AC) [kVA]		21.5		27.1		31.9		41.4
Max. input current								
Continuous (3x380-440 V) [A]	22	29	29	34	34	40	40	55
Intermittent (60 s overload) (3x380-440 V) [A]	35.2	31.9	46.4	37.4	54.4	44	64	60.5
Continuous (3x441-500 V) [A]	19	25	25	31	31	36	36	47
Intermittent (60 s overload) (3x441-500 V) [A]	30.4	27.5	40	34.1	49.6	39.6	57.6	51.7
Additional specifications								
IP21, IP55, IP66 max. cable cross-section ⁴⁾ for mains, brake and load sharing [mm ²] ([AWG])	16, 10, 16 (6, 8, 6)		16, 10, 16 (6, 8, 6)		35,-,-(2,-,-)		35,-,-(2,-,-)	
IP21, IP55, IP66 max. cable cross-section ⁴⁾ for motor [mm ²] ([AWG])	10, 10,- (8, 8,-)		10, 10,- (8, 8,-)		35, 25, 25 (2, 4, 4)		35, 25, 25 (2, 4, 4)	
IP20 max. cable cross-section ⁴⁾ for mains, brake, motor and load sharing [mm ²] ([AWG])	10, 10,- (8, 8,-)		10, 10,- (8, 8,-)		35,-,-(2,-,-)		35,-,-(2,-,-)	
Max. cable cross-section ⁴⁾ for Disconnect [mm ²] ([AWG])	16, 10, 10 (6, 8, 8)							
Estimated power loss at rated max. load [W] ³⁾	291	392	379	465	444	525	547	739
Efficiency ²⁾	0.98		0.98		0.98		0.98	

Table 8.5 Mains Supply 3x380-500 V AC (FC 302), 3x380-480 V AC (FC 301), P11K-P22K

Type Designation	P30K		P37K		P45K		P55K		P75K	
High/Normal Overload ¹⁾	HO	NO	HO	NO	HO	NO	HO	NO	HO	NO
Typical Shaft output [kW]	30	37	37	45	45	55	55	75	75	90
Enclosure IP21	C1		C1		C1		C2		C2	
Enclosure IP20	B4		C3		C3		C4		C4	
Enclosure IP55, IP66	C1		C1		C1		C2		C2	
Output current										
Continuous (3x380-440 V) [A]	61	73	73	90	90	106	106	147	147	177
Intermittent (60 s overload) (3x380-440 V) [A]	91.5	80.3	110	99	135	117	159	162	221	195
Continuous (3x441-500 V) [A]	52	65	65	80	80	105	105	130	130	160
Intermittent (60 s overload) (3x441-500 V) [A]	78	71.5	97.5	88	120	116	158	143	195	176
Continuous kVA (400 V AC) [kVA]	42.3	50.6	50.6	62.4	62.4	73.4	73.4	102	102	123
Continuous kVA (460 V AC) [kVA]		51.8		63.7		83.7		104		128
Max. input current										
Continuous (3x380-440 V) [A]	55	66	66	82	82	96	96	133	133	161
Intermittent (60 s overload) (3x380-440 V) [A]	82.5	72.6	99	90.2	123	106	144	146	200	177
Continuous (3x441-500 V) [A]	47	59	59	73	73	95	95	118	118	145
Intermittent (60 s overload) (3x441-500 V) [A]	70.5	64.9	88.5	80.3	110	105	143	130	177	160
Additional specifications										
IP20 max. cable cross-section for mains and motor [mm ²] ([AWG])	35 (2)		50 (1)		50 (1)		150 (300 MCM)		150 (300 MCM)	
IP20 max. cable cross-section for brake and load sharing [mm ²] ([AWG])	35 (2)		50 (1)		50 (1)		95 (4/0)		95 (4/0)	
IP21, IP55, IP66 max. cable cross- section for mains and motor [mm ²] ([AWG])	50 (1)		50 (1)		50 (1)		150 (300 MCM)		150 (300MCM)	
IP21, IP55, IP66 max. cable cross- section for brake and load sharing [mm ²] ([AWG])	50 (1)		50 (1)		50 (1)		95 (3/0)		95 (3/0)	
Max cable cross-section ⁴⁾ for mains disconnect [mm ²] ([AWG])			50, 35, 35 (1, 2, 2)				95, 70, 70 (3/0, 2/0, 2/0)		185, 150, 120 (350 MCM, 300 MCM, 4/0)	
Estimated power loss at rated max. load [W] ³⁾	570	698	697	843	891	1083	1022	1384	1232	1474
Efficiency ²⁾	0.98		0.98		0.98		0.98		0.99	

Table 8.6 Mains Supply 3x380-500 V AC (FC 302), 3x380-480 V AC (FC 301), P30K-P75K

8.1.3 Mains Supply 3x525-600 V AC (FC 302 only)

Type Designation	PK75	P1K1	P1K5	P2K2	P3K0	P4K0	P5K5	P7K5
Typical Shaft Output [kW]	0.75	1.1	1.5	2.2	3	4	5.5	7.5
Enclosure IP20, IP21	A3	A3	A3	A3	A3	A3	A3	A3
Enclosure IP55	A5	A5	A5	A5	A5	A5	A5	A5
Output current								
Continuous (3x525-550 V) [A]	1.8	2.6	2.9	4.1	5.2	6.4	9.5	11.5
Intermittent (3x525-550 V) [A]	2.9	4.2	4.6	6.6	8.3	10.2	15.2	18.4
Continuous (3x551-600 V) [A]	1.7	2.4	2.7	3.9	4.9	6.1	9.0	11.0
Intermittent (3x551-600 V) [A]	2.7	3.8	4.3	6.2	7.8	9.8	14.4	17.6
Continuous kVA (525 V AC) [kVA]	1.7	2.5	2.8	3.9	5.0	6.1	9.0	11.0
Continuous kVA (575 V AC) [kVA]	1.7	2.4	2.7	3.9	4.9	6.1	9.0	11.0
Max. input current								
Continuous (3x525-600 V) [A]	1.7	2.4	2.7	4.1	5.2	5.8	8.6	10.4
Intermittent (3x525-600 V) [A]	2.7	3.8	4.3	6.6	8.3	9.3	13.8	16.6
Additional specifications								
Max. cable cross-section ⁴⁾ for mains, motor, brake and load sharing [mm ²] ([AWG])	4,4,4 (12,12,12) (min. 0.2 (24))							
Max. cable cross-section ⁴⁾ for disconnect [mm ²] ([AWG])	6,4,4 (10,12,12)							
Estimated power loss at rated max. load [W] ³⁾	35	50	65	92	122	145	195	261
Efficiency ²⁾	0.97	0.97	0.97	0.97	0.97	0.97	0.97	0.97

Table 8.7 Mains Supply 3x525-600 V AC (FC 302 only), PK75-P7K5

Type Designation	P11K		P15K		P18K		P22K		P30K	
High/Normal Overload ¹⁾	HO	NO	HO	NO	HO	NO	HO	NO	HO	NO
Typical Shaft Output [kW]	11	15	15	18.5	18.5	22	22	30	30	37
Enclosure IP20	B3		B3		B4		B4		B4	
Enclosure IP21, IP55, IP66	B1		B1		B2		B2		C1	
Output current										
Continuous (3x525-550 V) [A]	19	23	23	28	28	36	36	43	43	54
Intermittent (3x525-550 V) [A]	30	25	37	31	45	40	58	47	65	59
Continuous (3x551-600 V) [A]	18	22	22	27	27	34	34	41	41	52
Intermittent (3x551-600 V) [A]	29	24	35	30	43	37	54	45	62	57
Continuous kVA (550 V AC) [kVA]	18.1	21.9	21.9	26.7	26.7	34.3	34.3	41.0	41.0	51.4
Continuous kVA (575 V AC) [kVA]	17.9	21.9	21.9	26.9	26.9	33.9	33.9	40.8	40.8	51.8
Max. input current										
Continuous at 550 V [A]	17.2	20.9	20.9	25.4	25.4	32.7	32.7	39	39	49
Intermittent at 550 V [A]	28	23	33	28	41	36	52	43	59	54
Continuous at 575 V [A]	16	20	20	24	24	31	31	37	37	47
Intermittent at 575 V [A]	26	22	32	27	39	34	50	41	56	52
Additional specifications										
IP20 max. cable cross-section ⁴⁾ for mains, brake, motor and load sharing [mm ²] ([AWG])	10, 10,- (8, 8,-)		10, 10,- (8, 8,-)		35,-,-(2,-,-)		35,-,-(2,-,-)		35,-,-(2,-,-)	
IP21, IP55, IP66 max. cable cross-section ⁴⁾ for mains, brake and load sharing [mm ²] ([AWG])	16, 10, 10 (6, 8, 8)		16, 10, 10 (6, 8, 8)		35,-,-(2,-,-)		35,-,-(2,-,-)		50,-,- (1,-,-)	
IP21, IP55, IP66 max. cable cross-section ⁴⁾ for motor [mm ²] ([AWG])	10, 10,- (8, 8,-)		10, 10,- (8, 8,-)		35, 25, 25 (2, 4, 4)		35, 25, 25 (2, 4, 4)		50,-,- (1,-,-)	
Max. cable cross-section ⁴⁾ for Disconnect [mm ²] ([AWG])	16, 10, 10 (6, 8, 8)								50, 35, 35 (1, 2, 2)	
Estimated power loss at rated max. load [W] ³⁾	220	300	300	370	370	440	440	600	600	740
Efficiency ²⁾	0.98		0.98		0.98		0.98		0.98	

Table 8.8 Mains Supply 3x525-600 V AC (FC 302 only), P11K-P30K

Type Designation	P37K		P45K		P55K		P75K	
High/Normal Overload ¹⁾	HO	NO	HO	NO	HO	NO	HO	NO
Typical Shaft Output [kW]	37	45	45	55	55	75	75	90
Enclosure IP20	C3	C3	C3		C4		C4	
Enclosure IP21, IP55, IP66	C1	C1	C1		C2		C2	
Output current								
Continuous (3x525-550 V) [A]	54	65	65	87	87	105	105	137
Intermittent (3x525-550 V) [A]	81	72	98	96	131	116	158	151
Continuous (3x551-600 V) [A]	52	62	62	83	83	100	100	131
Intermittent (3x551-600 V) [A]	78	68	93	91	125	110	150	144
Continuous kVA (550 V AC) [kVA]	51.4	61.9	61.9	82.9	82.9	100.0	100.0	130.5
Continuous kVA (575 V AC) [kVA]	51.8	61.7	61.7	82.7	82.7	99.6	99.6	130.5
Max. input current								
Continuous at 550 V [A]	49	59	59	78.9	78.9	95.3	95.3	124.3
Intermittent at 550 V [A]	74	65	89	87	118	105	143	137
Continuous at 575 V [A]	47	56	56	75	75	91	91	119
Intermittent at 575 V [A]	70	62	85	83	113	100	137	131
Additional specifications								
IP20 max. cable cross-section for mains and motor [mm ²] ([AWG])	50 (1)				150 (300 MCM)			
IP20 max. cable cross-section for brake and load sharing [mm ²] ([AWG])	50 (1)				95 (4/0)			
IP21, IP55, IP66 max. cable cross-section for mains and motor [mm ²] ([AWG])	50 (1)				150 (300 MCM)			
IP21, IP55, IP66 max. cable cross-section for brake and load sharing [mm ²] ([AWG])	50 (1)				95 (4/0)			
Max cable cross-section ⁴⁾ for mains disconnect [mm ²] ([AWG])	50, 35, 35 (1, 2, 2)				95, 70, 70 (3/0, 2/0, 2/0)		185, 150, 120 (350MCM, 300MCM, 4/0)	
Estimated power loss at rated max. load [W] ³⁾	740	900	900	1100	1100	1500	1500	1800
Efficiency ²⁾	0.98		0.98		0.98		0.98	

Table 8.9 Mains Supply 3x525-600 V AC (FC 302 only), P37K-P75K

8.1.4 Mains Supply 3x525-690 V AC (FC 302 only)

Type Designation	P1K1	P1K5	P2K2	P3K0	P4K0	P5K5	P7K5
High/Normal Overload ¹⁾	HO/NO	HO/NO	HO/NO	HO/NO	HO/NO	HO/NO	HO/NO
Typical Shaft output (kW)	1.1	1.5	2.2	3.0	4.0	5.5	7.5
Enclosure IP20	A3	A3	A3	A3	A3	A3	A3
Output current							
Continuous (3x525-550V) [A]	2.1	2.7	3.9	4.9	6.1	9.0	11.0
Intermittent (3x525-550V) [A]	3.4	4.3	6.2	7.8	9.8	14.4	17.6
Continuous (3x551-690V) [A]	1.6	2.2	3.2	4.5	5.5	7.5	10.0
Intermittent (3x551-690V) [A]	2.6	3.5	5.1	7.2	8.8	12.0	16.0
Continuous KVA 525 V AC	1.9	2.5	3.5	4.5	5.5	8.2	10.0
Continuous KVA 690 V AC	1.9	2.6	3.8	5.4	6.6	9.0	12.0
Max. input current							
Continuous (3x525-550V) [A]	1.9	2.4	3.5	4.4	5.5	8.1	9.9
Intermittent (3x525-550V) [A]	3.0	3.9	5.6	7.0	8.8	12.9	15.8
Continuous (3x551-690V) [A]	1.4	2.0	2.9	4.0	4.9	6.7	9.0
Intermittent (3x551-690V) [A]	2.3	3.2	4.6	6.5	7.9	10.8	14.4
Additional specifications							
Max. cable cross-section ⁴⁾ for mains, motor, brake and load sharing [mm ²] ([AWG])	4, 4, 4 (12, 12, 12) (min. 0.2 (24))						
Max. Cable cross-section ⁴⁾ for disconnect [mm ²] ([AWG])	6, 4, 4 (10, 12, 12)						
Estimated power loss at rated max. load (W) ³⁾	44	60	88	120	160	220	300
Efficiency ²⁾	0.96	0.96	0.96	0.96	0.96	0.96	0.96

8

Table 8.10 A3 Enclosure, Mains Supply 3x525-690 V AC IP20/Protected Chassis, P1K1-P7K5

Type Designation	P11K		P15K		P18K		P22K	
High/Normal Overload ¹⁾	HO	NO	HO	NO	HO	NO	HO	NO
Typical Shaft output at 550 V [kW]	7.5	11	11	15	15	18.5	18.5	22
Typical Shaft output at 690 V [kW]	11	15	15	18.5	18.5	22	22	30
Enclosure IP20	B4		B4		B4		B4	
Enclosure IP21, IP55	B2		B2		B2		B2	
Output current								
Continuous (3x525-550V) [A]	14.0	19.0	19.0	23.0	23.0	28.0	28.0	36.0
Intermittent (60 s overload) (3x525-550V) [A]	22.4	20.9	30.4	25.3	36.8	30.8	44.8	39.6
Continuous (3x551-690V) [A]	13.0	18.0	18.0	22.0	22.0	27.0	27.0	34.0
Intermittent (60 s overload) (3x551-690V) [A]	20.8	19.8	28.8	24.2	35.2	29.7	43.2	37.4
continuous KVA (at 550 V) [KVA]	13.3	18.1	18.1	21.9	21.9	26.7	26.7	34.3
continuous KVA (at 690 V AC) [KVA]	15.5	21.5	21.5	26.3	26.3	32.3	32.3	40.6
Max. input current								
Continuous (at 550 V) (A)	15.0	19.5	19.5	24.0	24.0	29.0	29.0	36.0
Intermittent (60 s overload) (at 550 V) (A)	23.2	21.5	31.2	26.4	38.4	31.9	46.4	39.6
Continuous (at 690 V) (A)	14.5	19.5	19.5	24.0	24.0	29.0	29.0	36.0
Intermittent (60 s overload) (at 690 V) (A)	23.2	21.5	31.2	26.4	38.4	31.9	46.4	39.6
Additional specifications								
Max. cable cross-section ⁴⁾ for mains/motor, load share and brake [mm ²] ([AWG])	35, 25, 25 (2, 4, 4)							
Max cable cross-section ⁴⁾ for mains disconnect [mm ²] ([AWG])	16,10,10 (6, 8, 8)							
Estimated power loss at rated max. load (W) ³⁾	150	220	220	300	300	370	370	440
Efficiency ²⁾	0.98		0.98		0.98		0.98	

Table 8.11 B2/B4 Enclosure, Mains Supply 3x525-690 V AC IP20/IP21/IP55 - Chassis/NEMA 1/NEMA 12 (FC 302 only), P11K-P22K

Type Designation	P30K		P37K		P45K		P55K		P75K	
High/Normal Overload ¹⁾	HO	NO	HO	NO	HO	NO	HO	NO	HO	NO
Typical Shaft output at 550 V (kW)	22	30	30	37	37	45	45	55	50	75
Typical Shaft output at 690 V [kW]	30	37	37	45	45	55	55	75	75	90
Enclosure IP20	B4		C3		C3		D3h		D3h	
Enclosure IP21, IP55	C2		C2		C2		C2		C2	
Output current										
Continuous (3x525-550V) [A]	36.0	43.0	43.0	54.0	54.0	65.0	65.0	87.0	87.0	105
Intermittent (60 s overload) (3x525-550V) [A]	54.0	47.3	64.5	59.4	81.0	71.5	97.5	95.7	130.5	115.5
Continuous (3x551-690V) [A]	34.0	41.0	41.0	52.0	52.0	62.0	62.0	83.0	83.0	100
Intermittent (60 s overload) (3x551-690V) [A]	51.0	45.1	61.5	57.2	78.0	68.2	93.0	91.3	124.5	110
continuous KVA (at 550 V AC) [KVA]	34.3	41.0	41.0	51.4	51.4	61.9	61.9	82.9	82.9	100
continuous KVA (at 690 V AC) [KVA]	40.6	49.0	49.0	62.1	62.1	74.1	74.1	99.2	99.2	119.5
Max. input current										
Continuous (at 550 V) [A]	36.0	49.0	49.0	59.0	59.0	71.0	71.0	87.0	87.0	99.0
Intermittent (60 s overload) (at 550 V) [A]	54.0	53.9	72.0	64.9	87.0	78.1	105.0	95.7	129	108.9
Continuous (at 690 V) [A]	36.0	48.0	48.0	58.0	58.0	70.0	70.0	86.0	-	-
Intermittent (60 s overload) (at 690 V) [A]	54.0	52.8	72.0	63.8	87.0	77.0	105	94.6	-	-
Additional specifications										
Max. cable-cross section for mains and motor [mm ²] ([AWG])	150 (300 MCM)									
Max. cable cross-section for load share and brake [mm ²] ([AWG])	95 (3/0)									
Max cable cross-section ⁴⁾ for mains disconnect [mm ²] ([AWG])	95, 70, 70 (3/0, 2/0, 2/0)						185, 150, 120 (350 MCM, 300 MCM, 4/0)		-	
Estimated power loss at rated max. load [W] ³⁾	600	740	740	900	900	1100	1100	1500	1500	1800
Efficiency ²⁾	0,98		0,98		0,98		0,98		0,98	

Table 8.12 B4, C2, C3 Enclosure, Mains Supply 3x525-690 V AC IP20/IP21/IP55 - Chassis/NEMA1/NEMA 12 (FC 302 only), P30K-P75K

For fuse ratings, see 8.7 Fuses and Circuit Breakers.

¹⁾ High overload=150% or 160% torque during 60 s. Normal overload=110% torque during 60 s.

²⁾ Measured using 5 m screened motor cables at rated load and rated frequency.

³⁾ The typical power loss is at nominal load conditions and expected to be within ±15% (tolerance relates to variety in voltage and cable conditions).

Values are based on a typical motor efficiency (eff2/eff3 border line). Motors with lower efficiency will also add to the power loss in the frequency converter and opposite.

If the switching frequency is increased compared to the default setting, the power losses may rise significantly.

LCP and typical control card power consumptions are included. Further options and customer load may add up to 30 W to the losses. (Though typical only 4 W extra for a fully loaded control card, or options for slot A or slot B, each).

Although measurements are made with state of the art equipment, some measurement inaccuracy must be allowed for (± 5%).

⁴⁾ The three values for the max. cable cross section are for single core, flexible wire and flexible wire with sleeve, respectively.

8.2 Mains Supply

Mains supply

Supply Terminals (6-Pulse)	L1, L2, L3
Supply Terminals (12-Pulse)	L1-1, L2-1, L3-1, L1-2, L2-2, L3-2
Supply voltage	200-240 V ±10%
Supply voltage	FC 301: 380-480 V/FC 302: 380-500 V ±10%
Supply voltage	FC 302: 525-600 V ±10%
Supply voltage	FC 302: 525-690 V ±10%

Mains voltage low/mains drop-out:

During low mains voltage or a mains drop-out, the frequency converter continues until the intermediate circuit voltage drops below the minimum stop level, which corresponds typically to 15% below the frequency converter's lowest rated supply voltage. Power-up and full torque cannot be expected at mains voltage lower than 10% below the frequency converter's lowest rated supply voltage.

Supply frequency	50/60 Hz ±5%
Max. imbalance temporary between mains phases	3.0 % of rated supply voltage
True Power Factor (λ)	≥ 0.9 nominal at rated load
Displacement Power Factor ($\cos \phi$)	near unity (> 0.98)
Switching on input supply L1, L2, L3 (power-ups) ≤ 7.5 kW	maximum 2 times/min.
Switching on input supply L1, L2, L3 (power-ups) 11-75 kW	maximum 1 time/min.
Switching on input supply L1, L2, L3 (power-ups) ≥ 90 kW	maximum 1 time/2 min.
Environment according to EN60664-1	overvoltage category III/pollution degree 2

The unit is suitable for use on a circuit capable of delivering not more than 100,000 RMS symmetrical Amperes, 240/500/600/690 V maximum.

8

8.3 Motor Output and Motor Data

Motor output (U, V, W¹⁾)

Output voltage	0-100% of supply voltage
Output frequency	0-590 Hz
Output frequency in Flux Mode	0-300 Hz
Switching on output	Unlimited
Ramp times	0.01-3600 s

Torque characteristics

Starting torque (constant torque)	maximum 160% for 60 s ¹⁾ once in 10 min.
Starting/overload torque (variable torque)	maximum 110% up to 0.5 s ¹⁾ once in 10 min.
Torque rise time in FLUX (for 5 kHz fsw)	1 ms
Torque rise time in VVC ^{plus} (independent of fsw)	10 ms

¹⁾ Percentage relates to the nominal torque.

²⁾ The torque response time depends on application and load but as a general rule, the torque step from 0 to reference is 4-5 x torque rise time.

8.4 Ambient Conditions

Environment

Enclosure	IP20/Chassis, IP21/Type 1, IP55/ Type 12, IP66/ Type 4X
Vibration test	1.0 g
Max. THVD	10%
Max. relative humidity	5% - 93% (IEC 721-3-3; Class 3K3 (non-condensing) during operation
Aggressive environment (IEC 60068-2-43) H ₂ S test	class Kd
Ambient temperature ¹⁾	Max. 50 °C (24-hour average maximum 45 °C)
Minimum ambient temperature during full-scale operation	0 °C
Minimum ambient temperature at reduced performance	- 10 °C
Temperature during storage/transport	-25 to +65/70 °C
Maximum altitude above sea level without derating	1000 m

Derating for high altitude, see special conditions in the Design Guide.

EMC standards, Emission	EN 61800-3
EMC standards, Immunity	EN 61800-3

See section on special conditions in the Design Guide..

¹⁾ *Derating for high ambient temperature, see special conditions in the Design Guide*

8

8.5 Cable Specifications

Cable lengths and cross sections for control cables¹⁾

Max. motor cable length, screened	150 m
Max. motor cable length, unscreened	300 m
Maximum cross section to control terminals, flexible/rigid wire without cable end sleeves	1.5 mm ² /16 AWG
Maximum cross section to control terminals, flexible wire with cable end sleeves	1 mm ² /18 AWG
Maximum cross section to control terminals, flexible wire with cable end sleeves with collar	0.5 mm ² /20 AWG
Minimum cross section to control terminals	0.25 mm ² /24 AWG

¹⁾ *For power cables, see electrical tables in 8.1 Electrical Data.*

8.6 Control Input/Output and Control Data

Digital inputs

Programmable digital inputs	FC 301: 4 (5) ¹⁾ /FC 302: 4 (6) ¹⁾
Terminal number	18, 19, 27 ¹⁾ , 29 ¹⁾ , 32, 33,
Logic	PNP or NPN
Voltage level	0 - 24 V DC
Voltage level, logic '0' PNP	< 5 V DC
Voltage level, logic '1' PNP	> 10 V DC
Voltage level, logic '0' NPN ²⁾	> 19 V DC
Voltage level, logic '1' NPN ²⁾	< 14 V DC
Maximum voltage on input	28 V DC
Pulse frequency range	0-110 kHz
(Duty cycle) Min. pulse width	4.5 ms
Input resistance, R _i	approx. 4 kΩ

Safe stop Terminal 37^{3, 4)} (Terminal 37 is fixed PNP logic)

Voltage level	0-24 V DC
Voltage level, logic'0' PNP	<4 V DC
Voltage level, logic'1' PNP	>20 V DC
Maximum voltage on input	28 V DC
Typical input current at 24 V	50 mA rms
Typical input current at 20 V	60 mA rms
Input capacitance	400 nF

All digital inputs are galvanically isolated from the supply voltage (PELV) and other high-voltage terminals.

¹⁾ Terminals 27 and 29 can also be programmed as output.

²⁾ Except safe stop input Terminal 37.

³⁾ See for further information about terminal 37 and Safe Stop.

⁴⁾ When using a contactor with a DC coil inside in combination with Safe Stop, it is important to make a return way for the current from the coil when turning it off. This can be done by using a freewheel diode (or, alternatively, a 30 or 50 V MOV for quicker response time) across the coil. Typical contactors can be bought with this diode.

Analog inputs

Number of analog inputs	2
Terminal number	53, 54
Modes	Voltage or current
Mode select	Switch S201 and switch S202
Voltage mode	Switch S201/switch S202 = OFF (U)
Voltage level	-10 to +10 V (scaleable)
Input resistance, R _i	approx. 10 kΩ
Max. voltage	± 20 V
Current mode	Switch S201/switch S202 = ON (I)
Current level	0/4 to 20 mA (scaleable)
Input resistance, R _i	approx. 200 Ω
Max. current	30 mA
Resolution for analog inputs	10 bit (+ sign)
Accuracy of analog inputs	Max. error 0.5% of full scale
Bandwidth	100 Hz

The analog inputs are galvanically isolated from the supply voltage (PELV) and other high-voltage terminals.

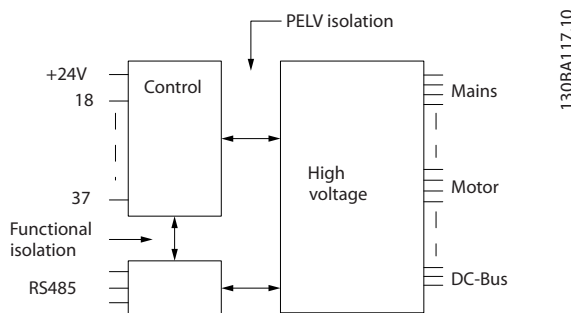

Illustration 8.1 PELV Isolation

Pulse/encoder inputs

Programmable pulse/encoder inputs	2/1
Terminal number pulse/encoder	29 ¹⁾ , 33 ²⁾ / 32 ³⁾ , 33 ³⁾
Max. frequency at terminal 29, 32, 33	110 kHz (Push-pull driven)
Max. frequency at terminal 29, 32, 33	5 kHz (open collector)
Min. frequency at terminal 29, 32, 33	4 Hz
Voltage level	see section on Digital input
Maximum voltage on input	28 V DC

Input resistance, R_i	approx. 4 k Ω
Pulse input accuracy (0.1-1 kHz)	Max. error: 0.1% of full scale
Encoder input accuracy (1-11 kHz)	Max. error: 0.05 % of full scale

The pulse and encoder inputs (terminals 29, 32, 33) are galvanically isolated from the supply voltage (PELV) and other high-voltage terminals.

¹⁾ FC 302 only

²⁾ Pulse inputs are 29 and 33

³⁾ Encoder inputs: 32 = A, and 33 = B

Digital output

Programmable digital/pulse outputs	2
Terminal number	27, 29 ¹⁾
Voltage level at digital/frequency output	0-24 V
Max. output current (sink or source)	40 mA
Max. load at frequency output	1 k Ω
Max. capacitive load at frequency output	10 nF
Minimum output frequency at frequency output	0 Hz
Maximum output frequency at frequency output	32 kHz
Accuracy of frequency output	Max. error: 0.1 % of full scale
Resolution of frequency outputs	12 bit

¹⁾ Terminal 27 and 29 can also be programmed as input.

The digital output is galvanically isolated from the supply voltage (PELV) and other high-voltage terminals.

Analog output

Number of programmable analog outputs	1
Terminal number	42
Current range at analog output	0/4 to 20 mA
Max. load GND - analog output less than	500 Ω
Accuracy on analog output	Max. error: 0.5% of full scale
Resolution on analog output	12 bit

The analog output is galvanically isolated from the supply voltage (PELV) and other high-voltage terminals.

Control card, 24 V DC output

Terminal number	12, 13
Output voltage	24 V +1, -3 V
Max. load	200 mA

The 24 V DC supply is galvanically isolated from the supply voltage (PELV), but has the same potential as the analog and digital inputs and outputs.

Control card, 10 V DC output

Terminal number	± 50
Output voltage	10.5 V ± 0.5 V
Max. load	15 mA

The 10 V DC supply is galvanically isolated from the supply voltage (PELV) and other high-voltage terminals.

Control card, RS-485 serial communication

Terminal number	68 (P,TX+, RX+), 69 (N,TX-, RX-)
Terminal number 61	Common for terminals 68 and 69

The RS-485 serial communication circuit is functionally separated from other central circuits and galvanically isolated from the supply voltage (PELV).

Control card, USB serial communication

USB standard	1.1 (Full speed)
USB plug	USB type B "device" plug

Connection to PC is carried out via a standard host/device USB cable.

The USB connection is galvanically isolated from the supply voltage (PELV) and other high-voltage terminals.

The USB ground connection is not galvanically isolated from protection earth. Use only an isolated laptop as PC connection to the USB connector on the frequency converter.

Relay outputs

Programmable relay outputs	FC 301 all kW: 1/FC 302 all kW: 2
Relay 01 Terminal number	1-3 (break), 1-2 (make)
Max. terminal load (AC-1) ¹⁾ on 1-3 (NC), 1-2 (NO) (Resistive load)	240 V AC, 2 A
Max. terminal load (AC-15) ¹⁾ (Inductive load @ cosφ 0.4)	240 V AC, 0.2 A
Max. terminal load (DC-1) ¹⁾ on 1-2 (NO), 1-3 (NC) (Resistive load)	60 V DC, 1 A
Max. terminal load (DC-13) ¹⁾ (Inductive load)	24 V DC, 0.1 A
Relay 02 (FC 302 only) Terminal number	4-6 (break), 4-5 (make)
Max. terminal load (AC-1) ¹⁾ on 4-5 (NO) (Resistive load) ²⁾³⁾ Overvoltage cat. II	400 V AC, 2 A
Max. terminal load (AC-15) ¹⁾ on 4-5 (NO) (Inductive load @ cosφ 0.4)	240 V AC, 0.2 A
Max. terminal load (DC-1) ¹⁾ on 4-5 (NO) (Resistive load)	80 V DC, 2 A
Max. terminal load (DC-13) ¹⁾ on 4-5 (NO) (Inductive load)	24 V DC, 0.1 A
Max. terminal load (AC-1) ¹⁾ on 4-6 (NC) (Resistive load)	240 V AC, 2 A
Max. terminal load (AC-15) ¹⁾ on 4-6 (NC) (Inductive load @ cosφ 0.4)	240 V AC, 0.2 A
Max. terminal load (DC-1) ¹⁾ on 4-6 (NC) (Resistive load)	50 V DC, 2 A
Max. terminal load (DC-13) ¹⁾ on 4-6 (NC) (Inductive load)	24 V DC, 0.1 A
Min. terminal load on 1-3 (NC), 1-2 (NO), 4-6 (NC), 4-5 (NO)	24 V DC 10 mA, 24 V AC 20 mA
Environment according to EN 60664-1	overvoltage category III/pollution degree 2

¹⁾ IEC 60947 part 4 and 5

The relay contacts are galvanically isolated from the rest of the circuit by reinforced isolation (PELV).

²⁾ Overvoltage Category II

³⁾ UL applications 300 V AC2A

Control card performance

Scan interval	1 ms
---------------	------

Control characteristics

Resolution of output frequency at 0-590 Hz	±0.003 Hz
Repeat accuracy of Precise start/stop (terminals 18, 19)	≤±0.1 ms
System response time (terminals 18, 19, 27, 29, 32, 33)	≤ 2 ms
Speed control range (open loop)	1:100 of synchronous speed
Speed control range (closed loop)	1:1000 of synchronous speed
Speed accuracy (open loop)	30-4000 rpm: error ±8 rpm
Speed accuracy (closed loop), depending on resolution of feedback device	0-6000 rpm: error ±0.15 rpm
Torque control accuracy (speed feedback)	max error ±5% of rated torque

All control characteristics are based on a 4-pole asynchronous motor



8.7 Fuses and Circuit Breakers

Use recommended fuses and/or circuit breakers on the supply side as protection in case of component break-down inside the frequency converter (first fault).

NOTICE

Use of fuses on the supply side is mandatory for IEC 60364 (CE) and NEC 2009 (UL) compliant installations.

Recommendations

- Fuses of the type gG
- Circuit breakers of Moeller types. By use of other circuit breaker types, ensure that the energy into the frequency converter is equal to or lower than the energy provided by Moeller types.

If fuses/circuit breakers according to recommendations are chosen, possible damages on the frequency converter will mainly be limited to damages inside the unit. For further information, see *Application Note Fuses and Circuit Breakers, MN.90.Tx.yy*.

The fuses below are suitable for use on a circuit capable of delivering 100,000 Arms (symmetrical), depending on the frequency converter voltage rating. With the proper fusing the frequency converter Short Circuit Current Rating (SCCR) is 100,000 Arms.

8

8.7.1 CE Compliance

200-240 V

Enclosure	Power [kW]	Recommended fuse size	Recommended Max. fuse	Recommended circuit breaker Moeller	Max trip level [A]
A1	0.25-1.5	gG-10	gG-25	PKZM0-16	16
A2	0.25-2.2	gG-10 (0.25-1.5) gG-16 (2.2)	gG-25	PKZM0-25	25
A3	3.0-3.7	gG-16 (3) gG-20 (3.7)	gG-32	PKZM0-25	25
A4	0.25-2.2	gG-10 (0.25-1.5) gG-16 (2.2)	gG-32	PKZM0-25	25
A5	0.25-3.7	gG-10 (0.25-1.5) gG-16 (2.2-3) gG-20 (3.7)	gG-32	PKZM0-25	25
B1	5.5-7.5	gG-25 (5.5) gG-32 (7.5)	gG-80	PKZM4-63	63
B2	11	gG-50	gG-100	NZMB1-A100	100
B3	5.5	gG-25	gG-63	PKZM4-50	50
B4	7.5-15	gG-32 (7.5) gG-50 (11) gG-63 (15)	gG-125	NZMB1-A100	100
C1	15-22	gG-63 (15) gG-80 (18.5) gG-100 (22)	gG-160 (15-18.5) aR-160 (22)	NZMB2-A200	160
C2	30-37	aR-160 (30) aR-200 (37)	aR-200 (30) aR-250 (37)	NZMB2-A250	250
C3	18.5-22	gG-80 (18.5) aR-125 (22)	gG-150 (18.5) aR-160 (22)	NZMB2-A200	150
C4	30-37	aR-160 (30) aR-200 (37)	aR-200 (30) aR-250 (37)	NZMB2-A250	250

Table 8.13 200-240 V, Enclosure Types A, B and C

380-500 V

Enclosure	Power [kW]	Recommended fuse size	Recommended Max. fuse	Recommended circuit breaker Moeller	Max trip level [A]
A1	0.37-1.5	gG-10	gG-25	PKZM0-16	16
A2	0.37-4.0	gG-10 (0.37-3) gG-16 (4)	gG-25	PKZM0-25	25
A3	5.5-7.5	gG-16	gG-32	PKZM0-25	25
A4	0.37-4	gG-10 (0.37-3) gG-16 (4)	gG-32	PKZM0-25	25
A5	0.37-7.5	gG-10 (0.37-3) gG-16 (4-7.5)	gG-32	PKZM0-25	25
B1	11-15	gG-40	gG-80	PKZM4-63	63
B2	18.5-22	gG-50 (18.5) gG-63 (22)	gG-100	NZMB1-A100	100
B3	11-15	gG-40	gG-63	PKZM4-50	50
B4	18.5-30	gG-50 (18.5) gG-63 (22) gG-80 (30)	gG-125	NZMB1-A100	100
C1	30-45	gG-80 (30) gG-100 (37) gG-160 (45)	gG-160	NZMB2-A200	160
C2	55-75	aR-200 (55) aR-250 (75)	aR-250	NZMB2-A250	250
C3	37-45	gG-100 (37) gG-160 (45)	gG-150 (37) gG-160 (45)	NZMB2-A200	150
C4	55-75	aR-200 (55) aR-250 (75)	aR-250	NZMB2-A250	250

Table 8.14 380-500 V, Enclosure Types A, B and C

525-600 V

Enclosure	Power [kW]	Recommended fuse size	Recommended Max. fuse	Recommended circuit breaker Moeller	Max trip level [A]
A2	0.75-4.0	gG-10	gG-25	PKZM0-25	25
A3	5.5-7.5	gG-10 (5.5) gG-16 (7.5)	gG-32	PKZM0-25	25
A5	0.75-7.5	gG-10 (0.75-5.5) gG-16 (7.5)	gG-32	PKZM0-25	25
B1	11-18	gG-25 (11) gG-32 (15) gG-40 (18.5)	gG-80	PKZM4-63	63
B2	22-30	gG-50 (22) gG-63 (30)	gG-100	NZMB1-A100	100
B3	11-15	gG-25 (11) gG-32 (15)	gG-63	PKZM4-50	50
B4	18.5-30	gG-40 (18.5) gG-50 (22) gG-63 (30)	gG-125	NZMB1-A100	100
C1	37-55	gG-63 (37) gG-100 (45) aR-160 (55)	gG-160 (37-45) aR-250 (55)	NZMB2-A200	160
C2	75	aR-200 (75)	aR-250	NZMB2-A250	250
C3	37-45	gG-63 (37) gG-100 (45)	gG-150	NZMB2-A200	150
C4	55-75	aR-160 (55) aR-200 (75)	aR-250	NZMB2-A250	250

Table 8.15 525-600 V, Enclosure Types A, B and C

525-690 V

Enclosure	Power [kW]	Recommended fuse size	Recommended Max. fuse	Recommended circuit breaker Moeller	Max trip level [A]
A3	1.1 1.5 2.2 3 4 5.5 7.5	gG-6 gG-6 gG-6 gG-10 gG-10 gG-16 gG-16	gG-25 gG-25 gG-25 gG-25 gG-25 gG-25 gG-25	PKZM0-16	16
B2/B4	11 15 18 22	gG-25 (11) gG-32 (15) gG-32 (18) gG-40 (22)	gG-63	-	-
B4/C2	30	gG-63 (30)	gG-80 (30)	-	-
C2/C3	37 45	gG-63 (37) gG-80 (45)	gG-100 (37) gG-125 (45)	-	-
C2	55 75	gG-100 (55) gG-125 (75)	gG-160 (55-75)	-	-

Table 8.16 525-690 V, Enclosure Types A, B and C

8.7.2 UL Compliance

200-240 V

Power [kW]	Recommended max. fuse					
	Bussmann Type RK1 ¹⁾	Bussmann Type J	Bussmann Type T	Bussmann Type CC	Bussmann Type CC	Bussmann Type CC
0.25-0.37	KTN-R-05	JKS-05	JJN-05	FNQ-R-5	KTK-R-5	LP-CC-5
0.55-1.1	KTN-R-10	JKS-10	JJN-10	FNQ-R-10	KTK-R-10	LP-CC-10
1.5	KTN-R-15	JKS-15	JJN-15	FNQ-R-15	KTK-R-15	LP-CC-15
2.2	KTN-R-20	JKS-20	JJN-20	FNQ-R-20	KTK-R-20	LP-CC-20
3.0	KTN-R-25	JKS-25	JJN-25	FNQ-R-25	KTK-R-25	LP-CC-25
3.7	KTN-R-30	JKS-30	JJN-30	FNQ-R-30	KTK-R-30	LP-CC-30
5.5	KTN-R-50	KS-50	JJN-50	-	-	-
7.5	KTN-R-60	JKS-60	JJN-60	-	-	-
11	KTN-R-80	JKS-80	JJN-80	-	-	-
15-18.5	KTN-R-125	JKS-125	JJN-125	-	-	-
22	KTN-R-150	JKS-150	JJN-150	-	-	-
30	KTN-R-200	JKS-200	JJN-200	-	-	-
37	KTN-R-250	JKS-250	JJN-250	-	-	-

Table 8.17 200-240 V, Enclosure Types A, B and C

8

Power [kW]	Recommended max. fuse							
	SIBA Type RK1	Littel fuse Type RK1	Ferraz-Shawmut Type CC	Ferraz-Shawmut Type RK1 ³⁾	Bussmann Type JFHR2 ²⁾	Littel fuse JFHR2	Ferraz-Shawmut JFHR2 ⁴⁾	Ferraz-Shawmut J
0.25-0.37	5017906-005	KLN-R-05	ATM-R-05	A2K-05-R	FWX-5	-	-	HSJ-6
0.55-1.1	5017906-010	KLN-R-10	ATM-R-10	A2K-10-R	FWX-10	-	-	HSJ-10
1.5	5017906-016	KLN-R-15	ATM-R-15	A2K-15-R	FWX-15	-	-	HSJ-15
2.2	5017906-020	KLN-R-20	ATM-R-20	A2K-20-R	FWX-20	-	-	HSJ-20
3.0	5017906-025	KLN-R-25	ATM-R-25	A2K-25-R	FWX-25	-	-	HSJ-25
3.7	5012406-032	KLN-R-30	ATM-R-30	A2K-30-R	FWX-30	-	-	HSJ-30
5.5	5014006-050	KLN-R-50	-	A2K-50-R	FWX-50	-	-	HSJ-50
7.5	5014006-063	KLN-R-60	-	A2K-60-R	FWX-60	-	-	HSJ-60
11	5014006-080	KLN-R-80	-	A2K-80-R	FWX-80	-	-	HSJ-80
15-18.5	2028220-125	KLN-R-125	-	A2K-125-R	FWX-125	-	-	HSJ-125
22	2028220-150	KLN-R-150	-	A2K-150-R	FWX-150	L25S-150	A25X-150	HSJ-150
30	2028220-200	KLN-R-200	-	A2K-200-R	FWX-200	L25S-200	A25X-200	HSJ-200
37	2028220-250	KLN-R-250	-	A2K-250-R	FWX-250	L25S-250	A25X-250	HSJ-250

Table 8.18 200-240 V, Enclosure Types A, B and C

- 1) KTS-fuses from Bussmann may substitute KTN for 240 V frequency converters.
- 2) FWH-fuses from Bussmann may substitute FWX for 240 V frequency converters.
- 3) A6KR fuses from FERRAZ SHAWMUT may substitute A2KR for 240 V frequency converters.
- 4) A50X fuses from FERRAZ SHAWMUT may substitute A25X for 240 V frequency converters.

380-500 V

Power [kW]	Recommended max. fuse					
	Bussmann Type RK1	Bussmann Type J	Bussmann Type T	Bussmann Type CC	Bussmann Type CC	Bussmann Type CC
0.37-1.1	KTS-R-6	JKS-6	JJS-6	FNQ-R-6	KTK-R-6	LP-CC-6
1.5-2.2	KTS-R-10	JKS-10	JJS-10	FNQ-R-10	KTK-R-10	LP-CC-10
3	KTS-R-15	JKS-15	JJS-15	FNQ-R-15	KTK-R-15	LP-CC-15
4	KTS-R-20	JKS-20	JJS-20	FNQ-R-20	KTK-R-20	LP-CC-20
5.5	KTS-R-25	JKS-25	JJS-25	FNQ-R-25	KTK-R-25	LP-CC-25
7.5	KTS-R-30	JKS-30	JJS-30	FNQ-R-30	KTK-R-30	LP-CC-30
11	KTS-R-40	JKS-40	JJS-40	-	-	-
15	KTS-R-50	JKS-50	JJS-50	-	-	-
18	KTS-R-60	JKS-60	JJS-60	-	-	-
22	KTS-R-80	JKS-80	JJS-80	-	-	-
30	KTS-R-100	JKS-100	JJS-100	-	-	-
37	KTS-R-125	JKS-125	JJS-125	-	-	-
45	KTS-R-150	JKS-150	JJS-150	-	-	-
55	KTS-R-200	JKS-200	JJS-200	-	-	-
75	KTS-R-250	JKS-250	JJS-250	-	-	-

Table 8.19 380-500 V, Enclosure Types A, B and C

Power [kW]	Recommended max. fuse							
	SIBA Type RK1	Littel fuse Type RK1	Ferraz-Shawmut Type CC	Ferraz-Shawmut Type RK1	Bussmann JFHR2	Ferraz-Shawmut J	Ferraz-Shawmut JFHR2 ¹⁾	Littel fuse JFHR2
0.37-1.1	5017906-006	KLS-R-6	ATM-R-6	A6K-6-R	FWH-6	HSJ-6	-	-
1.5-2.2	5017906-010	KLS-R-10	ATM-R-10	A6K-10-R	FWH-10	HSJ-10	-	-
3	5017906-016	KLS-R-15	ATM-R-15	A6K-15-R	FWH-15	HSJ-15	-	-
4	5017906-020	KLS-R-20	ATM-R-20	A6K-20-R	FWH-20	HSJ-20	-	-
5.5	5017906-025	KLS-R-25	ATM-R-25	A6K-25-R	FWH-25	HSJ-25	-	-
7.5	5012406-032	KLS-R-30	ATM-R-30	A6K-30-R	FWH-30	HSJ-30	-	-
11	5014006-040	KLS-R-40	-	A6K-40-R	FWH-40	HSJ-40	-	-
15	5014006-050	KLS-R-50	-	A6K-50-R	FWH-50	HSJ-50	-	-
18	5014006-063	KLS-R-60	-	A6K-60-R	FWH-60	HSJ-60	-	-
22	2028220-100	KLS-R-80	-	A6K-80-R	FWH-80	HSJ-80	-	-
30	2028220-125	KLS-R-100	-	A6K-100-R	FWH-100	HSJ-100	-	-
37	2028220-125	KLS-R-125	-	A6K-125-R	FWH-125	HSJ-125	-	-
45	2028220-160	KLS-R-150	-	A6K-150-R	FWH-150	HSJ-150	-	-
55	2028220-200	KLS-R-200	-	A6K-200-R	FWH-200	HSJ-200	A50-P-225	L50-S-225
75	2028220-250	KLS-R-250	-	A6K-250-R	FWH-250	HSJ-250	A50-P-250	L50-S-250

Table 8.20 380-500 V, Enclosure Types A, B and C

1) Ferraz-Shawmut A50QS fuses may substitute for A50P fuses.

525-600 V

Power [kW]	Recommended max. fuse									
	Bussmann Type RK1	Bussmann Type J	Bussmann Type T	Bussmann Type CC	Bussmann Type CC	Bussmann Type CC	SIBA Type RK1	Littel fuse Type RK1	Ferraz-Shawmut Type RK1	Ferraz-Shawmut J
0.75-1.1	KTS-R-5	JKS-5	JJS-6	FNQ-R-5	KTK-R-5	LP-CC-5	5017906-005	KLS-R-005	A6K-5-R	HSJ-6
1.5-2.2	KTS-R-10	JKS-10	JJS-10	FNQ-R-10	KTK-R-10	LP-CC-10	5017906-010	KLS-R-010	A6K-10-R	HSJ-10
3	KTS-R-15	JKS-15	JJS-15	FNQ-R-15	KTK-R-15	LP-CC-15	5017906-016	KLS-R-015	A6K-15-R	HSJ-15
4	KTS-R-20	JKS-20	JJS-20	FNQ-R-20	KTK-R-20	LP-CC-20	5017906-020	KLS-R-020	A6K-20-R	HSJ-20
5.5	KTS-R-25	JKS-25	JJS-25	FNQ-R-25	KTK-R-25	LP-CC-25	5017906-025	KLS-R-025	A6K-25-R	HSJ-25
7.5	KTS-R-30	JKS-30	JJS-30	FNQ-R-30	KTK-R-30	LP-CC-30	5017906-030	KLS-R-030	A6K-30-R	HSJ-30
11	KTS-R-35	JKS-35	JJS-35	-	-	-	5014006-040	KLS-R-035	A6K-35-R	HSJ-35
15	KTS-R-45	JKS-45	JJS-45	-	-	-	5014006-050	KLS-R-045	A6K-45-R	HSJ-45
18	KTS-R-50	JKS-50	JJS-50	-	-	-	5014006-050	KLS-R-050	A6K-50-R	HSJ-50
22	KTS-R-60	JKS-60	JJS-60	-	-	-	5014006-063	KLS-R-060	A6K-60-R	HSJ-60
30	KTS-R-80	JKS-80	JJS-80	-	-	-	5014006-080	KLS-R-075	A6K-80-R	HSJ-80
37	KTS-R-100	JKS-100	JJS-100	-	-	-	5014006-100	KLS-R-100	A6K-100-R	HSJ-100
45	KTS-R-125	JKS-125	JJS-125	-	-	-	2028220-125	KLS-R-125	A6K-125-R	HSJ-125
55	KTS-R-150	JKS-150	JJS-150	-	-	-	2028220-150	KLS-R-150	A6K-150-R	HSJ-150
75	KTS-R-175	JKS-175	JJS-175	-	-	-	2028220-200	KLS-R-175	A6K-175-R	HSJ-175

Table 8.21 525-600 V, Enclosure Types A, B and C



525-690 V

Power [kW]	Recommended max. fuse					
	Bussmann Type RK1	Bussmann Type J	Bussmann Type T	Bussmann Type CC	Bussmann Type CC	Bussmann Type CC
1.1	KTS-R-5	JKS-5	JJS-6	FNQ-R-5	KTK-R-5	LP-CC-5
1.5-2.2	KTS-R-10	JKS-10	JJS-10	FNQ-R-10	KTK-R-10	LP-CC-10
3	KTS-R-15	JKS-15	JJS-15	FNQ-R-15	KTK-R-15	LP-CC-15
4	KTS-R-20	JKS-20	JJS-20	FNQ-R-20	KTK-R-20	LP-CC-20
5.5	KTS-R-25	JKS-25	JJS-25	FNQ-R-25	KTK-R-25	LP-CC-25
7.5	KTS-R-30	JKS-30	JJS-30	FNQ-R-30	KTK-R-30	LP-CC-30
11	KTS-R-35	JKS-35	JJS-35	-	-	-
15	KTS-R-45	JKS-45	JJS-45	-	-	-
18	KTS-R-50	JKS-50	JJS-50	-	-	-
22	KTS-R-60	JKS-60	JJS-60	-	-	-
30	KTS-R-80	JKS-80	JJS-80	-	-	-
37	KTS-R-100	JKS-100	JJS-100	-	-	-
45	KTS-R-125	JKS-125	JJS-125	-	-	-
55	KTS-R-150	JKS-150	JJS-150	-	-	-
75	KTS-R-175	JKS-175	JJS-175	-	-	-

Table 8.22 525-690 V, Enclosure Types A, B and C

Power [kW]	Max. prefuse	Recommended max. fuse						
		Bussmann E52273 RK1/JDDZ	Bussmann E4273 J/JDDZ	Bussmann E4273 T/JDDZ	SIBA E180276 RK1/JDDZ	Littelfuse E81895 RK1/JDDZ	Ferraz-Shawmut E163267/E2137 RK1/JDDZ	Ferraz-Shawmut E2137 J/HSJ
11	30 A	KTS-R-30	JKS-30	JKJS-30	5017906-030	KLS-R-030	A6K-30-R	HST-30
15-18.5	45 A	KTS-R-45	JKS-45	JJS-45	5014006-050	KLS-R-045	A6K-45-R	HST-45
22	60 A	KTS-R-60	JKS-60	JJS-60	5014006-063	KLS-R-060	A6K-60-R	HST-60
30	80 A	KTS-R-80	JKS-80	JJS-80	5014006-080	KLS-R-075	A6K-80-R	HST-80
37	90 A	KTS-R-90	JKS-90	JJS-90	5014006-100	KLS-R-090	A6K-90-R	HST-90
45	100 A	KTS-R-100	JKS-100	JJS-100	5014006-100	KLS-R-100	A6K-100-R	HST-100
55	125 A	KTS-R-125	JKS-125	JJS-125	2028220-125	KLS-150	A6K-125-R	HST-125
75	150 A	KTS-R-150	JKS-150	JJS-150	2028220-150	KLS-175	A6K-150-R	HST-150

Table 8.23 525-690 V, Enclosure Types B and C

8.8 Connection Tightening Torques

Enclosure	Torque [Nm]					
	Mains	Motor	DC connection	Brake	Ground	Relay
A2	1.8	1.8	1.8	1.8	3	0.6
A3	1.8	1.8	1.8	1.8	3	0.6
A4	1.8	1.8	1.8	1.8	3	0.6
A5	1.8	1.8	1.8	1.8	3	0.6
B1	1.8	1.8	1.5	1.5	3	0.6
B2	4.5	4.5	3.7	3.7	3	0.6
B3	1.8	1.8	1.8	1.8	3	0.6
B4	4.5	4.5	4.5	4.5	3	0.6
C1	10	10	10	10	3	0.6
C2	14/24 ¹⁾	14/24 ¹⁾	14	14	3	0.6
C3	10	10	10	10	3	0.6
C4	14/24 ¹⁾	14/24 ¹⁾	14	14	3	0.6

Table 8.24 Tightening Terminals

¹⁾ For different cable dimensions x/y, where $x \leq 95 \text{ mm}^2$ and $y \geq 95 \text{ mm}^2$.

8.9 Power Ratings, Weight and Dimensions

Enclosure Type	A1	A2	A3	A4	A5	B1	B2	B3	B4	C1	C2	C3	C4	D3h
Rated Power [kW]	0.25-1.5	0.25-2.2	3-3.7	0.25-2.2	0.25-3.7	5.5-7.5	11	5.5-7.5	11-15	15-22	30-37	18.5-22	30-37	-
	0.37-1.5	0.37-4.0	5.5-7.5	0.37-4	0.37-7.5	11-15	18.5-22	11-15	18.5-30	30-45	55-75	37-45	55-75	-
IP NEMA			0.75-7.5		0.75-7.5	11-15	18.5-22	11-15	18.5-30	30-45	55-90	37-45	55-90	-
			1.1-7.5				11-22		11-30		30-75	37-45	37-45	55-75
Height [mm]	20	20	20	55/66	55/66	21/55/66	21/55/66	20	20	21/55/66	21/55/66	20	20	20
	Chassis	Chassis	Chassis	Type 1	Type 1	Type 1	Type 1	Chassis	Chassis	Type 1	Type 1	Chassis	Chassis	Chassis
Height of back plate	200	268	268	375	390	480	650	399	520	680	770	550	660	909
Height with de-coupling plate for Fieldbus cables	316	374	374	-	-	-	-	420	595	-	-	630	800	-
Distance between mounting holes	190	257	257	350	401	454	624	380	495	648	739	521	631	-
Width [mm]														
Width of back plate	75	90	130	200	242	242	242	165	230	308	370	308	370	250
Width of back plate with one C option														
Width of back plate with two C options [mm]														
Distance between mounting holes	60	70	110	171	215	210	210	140	200	272	334	270	330	-
Depth [mm]														
Depth without option A/B	207	205	205	175	200	260	260	249	242	310	335	333	333	375
With option A/B	222	220	220	175	200	260	260	262	242	310	335	333	333	375
Screw holes [mm]														
c	6.0	8.0	8.0	8.0	8.25	12	12	8		12.5	12.5			
d	ø8	ø11	ø11	ø11	ø12	ø19	ø19	12		ø19	ø19			
e	ø5	ø5.5	ø5.5	ø6.5	ø6.5	ø9	ø9	ø9	8.5	ø9	ø9	8.5	8.5	
f	5	9	6.5	6	9	9	9	7.9	15	9.8	9.8	17	17	
Max weight [kg]	2.7	4.9	5.3	9.7	13.5/14.2	23	27	12	23.5	45	65	35	50	62
Front cover tightening torque [Nm]														
Plastic cover (low IP)	Click	Click	Click	-	-	Click	Click	Click	Click	Click	Click	2.0	2.0	
Metal cover (IP55/66)	-	-	-	1.5	1.5	2.2	2.2	-	-	2.2	2.2	2.0	2.0	

Table 8.25 Power Ratings, Weight and Dimensions

9 Appendix

9.1 Symbols, Abbreviations and Conventions

AC	Alternating Current
AEO	Automatic Energy Optimization
AWG	American Wire Gauge
AMA	Automatic Motor Adaptation
°C	Degrees Celsius
DC	Direct Current
EMC	Electro Magnetic Compatibility
ETR	Electronic Thermal Relay
FC	Frequency Converter
LCP	Local Control Panel
MCT	Motion Control Tool
IP	Ingress Protection
$I_{M,N}$	Nominal Motor Current
$f_{M,N}$	Nominal Motor Frequency
$P_{M,N}$	Nominal Motor Power
$U_{M,N}$	Nominal Motor Voltage
PM Motor	Permanent Magnet Motor
PELV	Protective Extra Low Voltage
PCB	Printed Circuit Board
I_{LIM}	Current Limit
I_{INV}	Rated Inverter Output Current
RPM	Revolutions Per Minute
Regen	Regenerative Terminals
n_s	Synchronous Motor Speed
T_{LIM}	Torque Limit
$I_{VLT,MAX}$	The Maximum Output Current
$I_{VLT,N}$	The Rated Output Current Supplied by the Frequency Converter

Table 9.1 Symbols and Abbreviations

Conventions

Numbered lists indicate procedures.

Bullet lists indicate other information and description of illustrations.

Italicised text indicates

- cross reference
- link
- parameter name

9.2 Parameter Menu Structure

0-0*	Operation / Display	1-11	Motor Model	1-76	Start Current	3-03	Maximum Reference	4-1*	Motor Limits
0-0*	Basic Settings	1-14	Damping Gain	1-8*	Stop Adjustments	3-04	Reference Function	4-10	Motor Speed Direction
0-01	Language	1-15	Low Speed Filter Time Const.	1-80	Function at Stop	3-1*	References	4-11	Motor Speed Low Limit [RPM]
0-02	Motor Speed Unit	1-16	High Speed Filter Time Const.	1-81	Min Speed for Function at Stop [RPM]	3-10	Preset Reference	4-12	Motor Speed Low Limit [Hz]
0-03	Regional Settings	1-17	Voltage filter time const.	1-82	Min Speed for Function at Stop [Hz]	3-11	Jog Speed [Hz]	4-13	Motor Speed High Limit [RPM]
0-04	Operating State at Power-up (Hand)	1-2*	Motor Data	1-83	Precise Stop Function	3-12	Catch up/slow Down Value	4-14	Motor Speed High Limit [Hz]
0-09	Performance Monitor	1-20	Motor Power [kW]	1-84	Precise Stop Counter Value	3-13	Reference Site	4-16	Torque Limit Motor Mode
0-1*	Set-up Operations	1-21	Motor Power [HP]	1-85	Precise Stop Speed Compensation	3-14	Preset Relative Reference	4-17	Torque Limit Generator Mode
0-10	Active Set-up	1-22	Motor Voltage		Delay	3-15	Reference Resource 1	4-18	Current Limit
0-11	Edit Set-up	1-23	Motor Frequency	1-9*	Motor Temperature	3-16	Reference Resource 2	4-19	Max Output Frequency
0-12	This Set-up Linked to	1-24	Motor Current	1-90	Motor Thermal Protection	3-17	Reference Resource 3	4-2*	Limit Factors
0-13	Readout: Linked Set-ups	1-25	Motor Nominal Speed	1-91	Motor External Fan	3-18	Relative Scaling Reference Resource	4-20	Torque Limit Factor Source
0-14	Readout: Edit Set-ups / Channel	1-26	Motor Cont. Rated Torque	1-93	Thermistor Resource	3-19	Jog Speed [RPM]	4-21	Speed Limit Factor Source
0-15	Readout: actual setup	1-29	Automatic Motor Adaptation (AMA)	1-94	ATEX ETR cur.lim. speed reduction	3-4*	Ramp 1	4-3*	Motor Speed Mon.
0-2*	LCP Display	1-3*	Adv. Motor Data	1-95	KTY Sensor Type	3-40	Ramp 1 Type	4-30	Motor Feedback Loss Function
0-20	Display Line 1.1 Small	1-30	Stator Resistance (Rs)	1-96	KTY Thermistor Resource	3-41	Ramp 1 Ramp Up Time	4-31	Motor Feedback Speed Error
0-21	Display Line 1.2 Small	1-31	Rotor Resistance (Rr)	1-97	KTY Threshold level	3-42	Ramp 1 Ramp Down Time	4-32	Motor Feedback Loss Timeout
0-22	Display Line 1.3 Small	1-33	Stator Leakage Reactance (X1)	1-98	ATEX ETR interpol. points freq.	3-45	Ramp 1 S-ramp Ratio at Accel. Start	4-34	Tracking Error Function
0-23	Display Line 2 Large	1-34	Rotor Leakage Reactance (X2)	1-99	ATEX ETR interpol. points current	3-46	Ramp 1 S-ramp Ratio at Accel. End	4-35	Tracking Error
0-24	Display Line 3 Large	1-35	Main Reactance (Xh)	2-*	Brakes	3-47	Ramp 1 S-ramp Ratio at Decel. Start	4-36	Tracking Error Timeout
0-25	My Personal Menu	1-36	Iron Loss Resistance (Rfe)	2-0*	DC-Brake	3-48	Ramp 1 S-ramp Ratio at Decel. End	4-37	Tracking Error Ramping
0-3*	LCP Custom Readout	1-37	d-axis Inductance (Ld)	2-00	DC Hold Current	3-5*	Ramp 2	4-38	Tracking Error Ramping Timeout
0-30	Unit for User-defined Readout	1-38	q-axis Inductance (Lq)	2-01	DC Brake Current	3-50	Ramp 2 Type	4-39	Tracking Error After Ramping Timeout
0-31	Min Value of User-defined Readout	1-39	Motor Poles	2-02	DC Braking Time	3-51	Ramp 2 Ramp Up Time	4-5*	Adj. Warnings
0-32	Max Value of User-defined Readout	1-40	Back EMF at 1000 RPM	2-03	DC Brake Cut In Speed [Hz]	3-52	Ramp 2 Ramp Down Time	4-50	Warning Current Low
0-37	Display Text 1	1-41	Motor Angle Offset	2-04	DC Brake Cut In Speed [RPM]	3-55	Ramp 2 S-ramp Ratio at Accel. Start	4-51	Warning Current High
0-38	Display Text 2	1-44	d-axis Inductance Sat. (LdSat)	2-05	Maximum Reference	3-56	Ramp 2 S-ramp Ratio at Accel. End	4-52	Warning Speed Low
0-39	Display Text 3	1-45	q-axis Inductance Sat. (LqSat)	2-06	Maximum Reference	3-57	Ramp 2 S-ramp Ratio at Decel. Start	4-53	Warning Speed High
0-4*	LCP keypad	1-46	Position Detection Gain	2-07	Parking Time	3-58	Ramp 2 S-ramp Ratio at Decel. End	4-54	Warning Reference Low
0-40	[Hand on] key on LCP	1-47	Low Speed Torque Calibration	2-1*	Brake Energy Funct.	3-6*	Ramp 3	4-55	Warning Reference High
0-41	[Off] key on LCP	1-48	Inductance Sat. Point	2-10	Brake Function	3-60	Ramp 3 Type	4-56	Warning Feedback Low
0-42	[Auto on] key on LCP	1-5*	Load Indep. Setting	2-11	Brake Resistor (ohm)	3-61	Ramp 3 Ramp up Time	4-57	Warning Feedback High
0-43	[Reset] key on LCP	1-50	Motor Magnetisation at Zero Speed	2-12	Brake Power Limit (kW)	3-62	Ramp 3 Ramp down Time	4-58	Missing Motor Phase Function
0-44	[Off/Reset] key on LCP	1-51	Min Speed Normal Magnetising [RPM]	2-13	Brake Power Monitoring	3-65	Ramp 3 S-ramp Ratio at Accel. Start	4-6*	Speed Bypass
0-45	[Drive Bypass] key on LCP	1-52	Min Speed Normal Magnetising [Hz]	2-15	Brake Check	3-66	Ramp 3 S-ramp Ratio at Accel. End	4-60	Bypass Speed From [RPM]
0-5*	Copy/Save	1-53	Model Shift Frequency	2-16	AC brake Max. Current	3-67	Ramp 3 S-ramp Ratio at Decel. Start	4-61	Bypass Speed From [Hz]
0-50	LCP Copy	1-54	Voltage reduction in fieldweakening	2-17	Over-voltage Control	3-68	Ramp 3 S-ramp Ratio at Decel. End	4-62	Bypass Speed To [RPM]
0-51	Set-up Copy	1-55	U/f Characteristic - U	2-18	Brake Check Condition	3-7*	Ramp 4	4-63	Bypass Speed To [Hz]
0-6*	Password	1-56	U/f Characteristic - F	2-19	Over-voltage Gain	3-70	Ramp 4 Type	5-*	Digital In/Out
0-60	Main Menu Password	1-58	Flystart Test Pulses Current	2-2*	Mechanical Brake	3-71	Ramp 4 Ramp up Time	5-0*	Digital I/O mode
0-61	Access to Main Menu w/o Password	1-59	Load Depen. Setting	2-20	Release Brake Current	3-72	Ramp 4 Ramp Down Time	5-00	Digital I/O Mode
0-65	Quick Menu Password	1-6*	Low Speed Load Compensation	2-21	Activate Brake Speed [RPM]	3-75	Ramp 4 S-ramp Ratio at Accel. Start	5-01	Terminal 27 Mode
0-66	Access to Quick Menu w/o Password	1-60	High Speed Load Compensation	2-22	Activate Brake Speed [Hz]	3-76	Ramp 4 S-ramp Ratio at Accel. End	5-02	Terminal 29 Mode
0-67	Bus Password Access	1-61	Slip Compensation	2-23	Activate Brake Delay	3-77	Ramp 4 S-ramp Ratio at Decel. Start	5-1*	Digital Inputs
0-68	Safety Parameters Password	1-62	Resonance Dampening Time Constant	2-24	Stop Delay	3-78	Ramp 4 S-ramp Ratio at Decel. End	5-10	Terminal 18 Digital Input
0-69	Password Protection of Safety Parameters	1-63	Resonance Dampening Time Constant	2-25	Brake Release Time	3-8*	Other Ramps	5-11	Terminal 19 Digital Input
1-*	Load and Motor	1-64	Min. Current at Low Speed	2-26	Torque Ref	3-80	Jog Ramp Time	5-12	Terminal 27 Digital Input
1-0*	General Settings	1-66	Load Type	2-27	Torque Ramp Time	3-81	Quick Stop Ramp Type	5-13	Terminal 29 Digital Input
1-00	Configuration Mode	1-67	Minimum Inertia	2-28	Gain Boost Factor	3-82	Quick Stop Ramp Type	5-14	Terminal 32 Digital Input
1-01	Motor Control Principle	1-68	Maximum Inertia	2-29	Torque Ramp Down Time	3-83	Quick Stop S-ramp Ratio at Decel. Start	5-15	Terminal 33 Digital Input
1-02	Flux Motor Feedback Source	1-69	Start Adjustments	2-30	Position P Start Proportional Gain	3-84	Quick Stop S-ramp Ratio at Decel. End	5-16	Terminal X30/2 Digital Input
1-03	Torque Characteristics	1-7*	PM Start Mode	2-31	Speed PID Start Proportional Gain	3-9*	Digital Pot.Meter	5-17	Terminal X30/3 Digital Input
1-04	Overload Mode	1-70	Start Delay	2-32	Speed PID Start Integral Time	3-90	Step Size	5-18	Terminal X30/4 Digital Input
1-05	Local Mode Configuration	1-71	Start Delay	3-*	Reference / Ramps	3-91	Ramp Time	5-19	Terminal 37 Safe Stop
1-06	Motor Angle Offset Adjust	1-72	Start Function	3-0*	Reference Limits	3-92	Power Restore	5-20	Terminal X46/1 Digital Input
1-1*	Special Settings	1-73	Flying Start	3-00	Reference Range	3-93	Maximum Limit	5-21	Terminal X46/3 Digital Input
1-10	Motor Construction	1-74	Start Speed [RPM]	3-01	Reference/Feedback Unit	3-94	Minimum Limit	5-22	Terminal X46/5 Digital Input
		1-75	Start Speed [Hz]	3-02	Minimum Reference	3-95	Ramp Delay	5-23	Terminal X46/7 Digital Input
				4-*	Limits / Warnings			5-24	Terminal X46/9 Digital Input

5-25	Terminal X46/11 Digital Input	7-31	Process PID Anti Windup	8-53	Start Select	10-12	Process Data Config Read
5-26	Terminal X46/13 Digital Input	7-32	Process PID Start Speed	8-54	Reversing Select	10-13	Warning Parameter
5-3*	Digital Outputs	7-33	Process PID Proportional Gain	8-55	Set-up Select	10-14	Net Reference
5-30	Terminal 27 Digital Output	7-34	Process PID Integral Time	8-56	Preset Reference Select	10-15	Net Control
5-31	Terminal 29 Digital Output	7-35	Process PID Differentiation Time	8-57	Profidrive OFF2 Select	10-2*	COS Filters
5-32	Term X30/6 Digi Out (MCB 101)	7-36	Process PID Diff. Gain Limit	8-58	Profidrive OFF3 Select	10-20	COS Filter 1
5-33	Term X30/7 Digi Out (MCB 101)	7-38	Process PID Feed Forward Factor	8-8*	FC Port Diagnostics	10-21	COS Filter 2
5-4*	Relays	7-39	On Reference Bandwidth	8-80	Bus Message Count	10-22	COS Filter 3
5-40	Function Relay	7-4*	Adv. Process PID I	8-81	Bus Error Count	10-23	COS Filter 4
5-41	On Delay, Relay	7-40	Process PID I-part Reset	8-82	Slave Messages Rcvd	10-3*	Parameter Access
5-42	Off Delay, Relay	7-41	Process PID Output Neg. Clamp	8-83	Slave Error Count	10-30	Array Index
5-5*	Pulse Input	7-42	Process PID Output Pos. Clamp	8-9*	Bus Jog	10-31	Store Data Values
5-50	Term. 29 Low Frequency	7-43	Process PID Gain Scale at Min. Ref.	8-90	Bus Jog 1 Speed	10-32	Devicenet Revision
5-51	Term. 29 High Frequency	7-44	Process PID Gain Scale at Max. Ref.	8-91	Bus Jog 2 Speed	10-33	Store Always
5-52	Term. 29 Low Ref./Feedb. Value	7-45	Process PID Feed Fwd Resource	9-*	PROFidrive	10-34	Devicenet Product Code
5-53	Term. 29 High Ref./Feedb. Value	7-46	Process PID Feed Fwd Normal/ Inv. Ctrl.	9-00	Setpoint	10-39	Devicenet F Parameters
5-54	Pulse Filter Time Constant #29	7-48	PCD Feed Forward	9-07	Actual Value	10-5*	CANopen
5-55	Term. 33 Low Frequency	7-49	Process PID Output Normal/ Inv. Ctrl.	9-15	PCD Write Configuration	10-50	Process Data Config Write.
5-56	Term. 33 High Frequency	7-5*	Adv. Process PID II	9-16	PCD Read Configuration	10-51	Process Data Config Read.
5-57	Term. 33 Low Ref./Feedb. Value	7-50	Process PID Extended PID	9-18	Node Address	12-0*	Ethernet
5-58	Term. 33 High Ref./Feedb. Value	7-51	Process PID Feed Fwd Ramp up	9-22	Telegram Selection	12-0*	IP Settings
5-59	Pulse Filter Time Constant #33	7-52	Process PID Feed Fwd Ramp down	9-23	Parameters for Signals	12-00	IP Address Assignment
5-60	Terminal 27 Pulse Output Variable	7-53	Process PID Feed Fwd Ramp down	9-27	Parameter Edit	12-01	IP Address
5-62	Pulse Output Max Freq #27	7-56	Process PID Ref. Filter Time	9-28	Process Control	12-02	Subnet Mask
5-63	Terminal 29 Pulse Output Variable	7-57	Process PID Fb. Filter Time	9-44	Fault Message Counter	12-03	Default Gateway
5-65	Pulse Output Max Freq #29	8-*	Comm. and Options	9-45	Fault Code	12-04	DHCP Server
5-66	Terminal X30/6 Pulse Output Variable	8-0*	General Settings	9-47	Fault Number	12-05	Lease Expires
5-68	Pulse Output Max Freq #X30/6	8-01	Control Site	9-52	Profibus Warning Word	12-06	Name Servers
5-7*	24V Encoder Inq	8-02	Control Word Source	9-53	Profibus Warning Word	12-07	Domain Name
5-70	Term 32/33 Pulses Per Revolution	8-03	Control Word Timeout Time	9-63	Actual Baud Rate	12-08	Host Name
5-71	Term 32/33 Encoder Direction	8-04	Control Word Timeout Function	9-64	Device Identification	12-09	Physical Address
5-8*	I/O Options	8-05	End-of-Timeout Function	9-65	Profile Number	12-1*	Ethernet Link Parameters
5-80	AHF Cap Reconnect Delay	8-06	Reset Control Word Timeout	9-67	Control Word 1	12-10	Link Status
5-9*	Bus Controlled	8-07	Diagnosis Trigger	9-71	Profibus Save Data Values	12-11	Link Duration
5-90	Digital & Relay Bus Control	8-08	Readout Filtering	9-72	ProfibusDriveReset	12-12	Auto Negotiation
5-93	Pulse Out #27 Bus Control	8-1*	Ctrl. Word Settings	9-75	DO Identification	12-13	Link Speed
5-94	Pulse Out #27 Timeout Preset	8-10	Control Word Profile	9-80	Defined Parameters (1)	12-14	Link Duplex
5-95	Pulse Out #29 Bus Control	8-13	Configurable Status Word STW	9-81	Defined Parameters (2)	12-2*	Process Data
5-96	Pulse Out #29 Timeout Preset	8-14	Configurable Control Word CTW	9-82	Defined Parameters (3)	12-21	Process Data Config Write
5-97	Pulse Out #X30/6 Bus Control	8-19	Product Code	9-83	Defined Parameters (4)	12-22	Process Data Config Read
5-98	Pulse Out #X30/6 Timeout Preset	8-3*	FC Port Settings	9-84	Defined Parameters (5)	12-23	Process Data Config Write Size
6-0*	Analog I/O Mode	8-30	Protocol	9-90	Changed Parameters (1)	12-24	Process Data Config Read Size
6-00	Live Zero Timeout Time	8-31	Address	9-91	Changed Parameters (2)	12-27	Master Address
6-01	Live Zero Timeout Function	8-32	FC Port Baud Rate	9-92	Changed Parameters (3)	12-28	Store Data Values
6-1*	Analog Input 1	8-33	Parity / Stop Bits	9-93	Changed Parameters (4)	12-29	Store Always
6-10	Terminal 53 Low Voltage	8-34	Estimated cycle time	9-94	Changed Parameters (5)	12-3*	EtherNet/IP
6-11	Terminal 53 High Voltage	8-36	Minimum Response Delay	9-99	Profibus Revision Counter	12-30	Warning Parameter
6-12	Terminal 53 Low Current	8-37	Max Inter-Char Delay	10-0*	CAN Fields	12-31	Net Reference
6-13	Terminal 53 High Current	8-40	FC MC protocol set	10-00	CAN Protocol	12-32	Net Control
6-14	Terminal 53 Low Ref./Feedb. Value	8-41	Telegram Selection	10-01	CIP Revision	12-33	CIP Revision
6-15	Terminal 53 High Ref./Feedb. Value	8-42	Parameters for Signals	10-02	Baud Rate Select	12-34	CIP Product Code
6-16	Terminal 53 Filter Time Constant	8-43	PCD Write Configuration	10-05	MAC ID	12-35	EDS Parameter
6-2*	Analog Input 2	8-5*	Digital/Bus	10-06	Readout Transmit Error Counter	12-37	COS Inhibit Timer
6-20	Terminal 54 Low Voltage	8-50	Coasting Select	10-07	Readout Receive Error Counter	12-38	COS Filter
6-21	Terminal 54 High Voltage	8-51	Quick Stop Select	10-1*	DeviceNet	12-40	Status Parameter
6-22	Terminal 54 Low Current	8-52	DC Brake Select	10-10	Process Data Type Selection	12-41	Slave Message Count
6-23	Terminal 54 High Current			10-11	Process Data Config Write	12-42	Slave Exception Message Count

12-5* EtherCAT	14-10 Mains Failure	15-13 Logging Mode	16-12 Motor Voltage	16-80 Fieldbus CTW 1
12-50 Configured Station Alias	14-11 Mains Voltage at Mains Fault	15-14 Samples Before Trigger	16-13 Frequency	16-82 Fieldbus REF 1
12-51 Configured Station Address	14-12 Function at Mains Imbalance	15-2* Historic Log	16-14 Motor current	16-84 Comm. Option STW
12-59 EtherCAT Status	14-13 Mains Failure Step Fault	15-21 Historic Log: Event	16-15 Frequency [%]	16-85 FC Port CTW 1
12-60 Node ID	14-14 Kin. Backup Time Out	15-22 Historic Log: Value	16-16 Torque [Nm]	16-86 FC Port REF 1
12-62 SDO Timeout	14-15 Kin. Backup Trip Recovery Level	15-22 Historic Log: Time	16-17 Speed [RPM]	16-87 Bus Readout Alarm/Warning
12-63 Basic Ethernet Timeout	14-20 Trip Reset	15-3* Fault Log	16-18 Motor Thermal	16-9* Diagnosis Readouts
12-66 Threshold	14-20 Reset Mode	15-30 Fault Log: Error Code	16-19 KTY sensor temperature	16-90 Alarm Word
12-67 Threshold Counters	14-21 Automatic Restart Time	15-31 Fault Log: Value	16-20 Motor Angle	16-91 Alarm Word 2
12-68 Cumulative Counters	14-22 Operation Mode	15-32 Fault Log: Time	16-21 Torque [%] High Res.	16-92 Warning Word 2
12-69 Ethernet PowerLink Status	14-23 Typecode Setting	15-4* Drive Identification	16-22 Torque [%]	16-94 Ext. Status Word
12-8* EtherNet Services	14-24 Trip Delay at Current Limit	15-40 FC Type	16-23 Motor Shaft Power [kW]	17-1** Feedback Option
12-80 FTP Server	14-25 Trip Delay at Torque Limit	15-41 Power Section	16-24 Calibrated Stator Resistance	17-1* Inc. Enc. Interface
12-81 HTTP Server	14-26 Trip Delay at Inverter Fault	15-42 Voltage	16-25 Torque [Nm] High	17-10 Signal Type
12-82 SMTP Service	14-28 Production Settings	15-43 Software Version	16-3* Drive Status	17-11 Resolution (PPR)
12-89 Transparent Socket Channel Port	14-29 Service Code	15-44 Ordered Typecode String	16-30 DC Link Voltage	17-12* Abs. Enc. Interface
12-9* Advanced Ethernet Services	14-30 Current Limit Ctrl.	15-45 Actual Typecode String	16-32 Brake Energy /s	17-20 Protocol Selection
12-90 Cable Diagnostic	14-30 Current Lim Ctrl, Proportional Gain	15-46 Frequency Converter Ordering No	16-33 Brake Energy /2 min	17-21 Resolution (Positions/Rev)
12-91 Auto Cross Over	14-31 Current Lim Ctrl, Integration Time	15-47 Power Card Ordering No	16-34 Heatsink Temp.	17-24 SSI Data Length
12-92 IGMP Snooping	14-32 Current Lim Ctrl, Filter Time	15-48 LCP Id No	16-35 Inverter Thermal	17-25 Clock Rate
12-93 Cable Error Length	14-35 Stall Protection	15-49 SW ID Control Card	16-36 Inv. Nom. Current	17-34 HiPERFACE Baudrate
12-94 Broadcast Storm Protection	14-36 Fieldweakening Function	15-50 SW ID Power Card	16-37 Inv. Max. Current	17-5* Resolver Interface
12-95 Broadcast Storm Filter	14-4* Energy Optimising	15-51 Frequency Converter Serial Number	16-38 SL Controller State	17-50 Poles
12-96 Port Config	14-40 VT Level	15-53 Power Card Serial Number	16-39 Control Card Temp.	17-51 Input Voltage
12-98 Interface Counters	14-41 AEO Minimum Magnetisation	15-53 Smart Setup Filename	16-40 Logging Buffer Full	17-52 Input Frequency
12-99 Media Counters	14-42 Minimum AEO Frequency	15-59 CSIV Filename	16-41 LCP Bottom Statusline	17-53 Transformation Ratio
13-1** Smart Logic	14-43 Motor Cosphi	15-56* Option Ident	16-45 Motor Phase U Current	17-56 Encoder Sim. Resolution
13-00 SLC Settings	14-5* Environment	15-60 Option Mounted	16-46 Motor Phase V Current	17-59 Resolver Interface
13-01 Start Event	14-50 RFI Filter	15-61 Option SW Version	16-47 Motor Phase W Current	17-6* Monitoring and App.
13-02 Stop Event	14-51 DC Link Compensation	15-62 Option Ordering No	16-48 Speed Ref. After Ramp [RPM]	17-60 Feedback Direction
13-03 Reset SLC	14-52 Fan Control	15-63 Option Serial No	16-49 Current Fault Source	18-1** Data Readouts 2
13-1* Comparators	14-53 Fan Monitor	15-70 Option in Slot A	16-5* Ref. & Feedsb.	18-3* Analog Readouts
13-10 Comparator Operand	14-55 Output Filter	15-71 Slot A Option SW Version	16-50 External Reference	18-36 Analog Input X48/2 [mA]
13-11 Comparator Operator	14-56 Capacitance Output Filter	15-72 Option in Slot B	16-51 Pulse Reference	18-37 Temp. Input X48/4
13-12 Comparator Value	14-57 Inductance Output Filter	15-73 Slot B Option SW Version	16-52 Feedback[Unit]	18-38 Temp. Input X48/7
13-1* RS Flip Flops	14-59 Actual Number of Inverter Units	15-74 Option in Slot C0/E0	16-53 Digi Pot Reference	18-39 Temp. Input X48/10
13-15 RS-FF Operand S	14-7* Compatibility	15-75 Slot C0/E0 Option SW Version	16-57 Feedback [RPM]	18-6* Inputs & Outputs 2
13-16 RS-FF Operand R	14-72 Legacy Alarm Word	15-76 Option in Slot C1/E1	16-6* Inputs & Outputs	18-60 Digital Input 2
13-2* Timers	14-73 Legacy Warning Word	15-77 Slot C1/E1 Option SW Version	16-60 Digital Input	18-9* PID Readouts
13-4* Logic Rules	14-74 Leg. Ext. Status Word	15-8* Operating Data II	16-61 Terminal 53 Switch Setting	18-90 Process PID Error
13-40 Logic Rule Boolean 1	14-8* Options	15-80 Fan Running Hours	16-62 Analog Input 53	18-91 Process PID Output
13-41 Logic Rule Operator 1	14-80 Option Supplied by External 24VDC	15-81 Preset Fan Running Hours	16-63 Terminal 54 Switch Setting	18-92 Process PID Clamped Output
13-42 Logic Rule Boolean 2	14-89 Option Detection	15-89 Configuration Change Counter	16-64 Analog Input 54	18-93 Process PID Gain Scaled Output
13-43 Logic Rule Operator 2	14-9* Fault Settings	15-9* Parameter Info	16-65 Analog Output 42 [mA]	30-0** Special Features
13-44 Logic Rule Boolean 3	14-90 Fault Level	15-92 Defined Parameters	16-66 Digital Output [bin]	30-0* Wobbler
13-5* States	15-0** Drive Information	15-93 Modified Parameters	16-67 Freq. Input #29 [Hz]	30-00 Wobble Mode
13-51 SL Controller Event	15-0* Operating Data	15-98 Drive Identification	16-68 Freq. Input #33 [Hz]	30-01 Wobble Delta Frequency [Hz]
13-52 SL Controller Action	15-01 Running Hours	15-99 Parameter Metadata	16-69 Pulse Output #27 [Hz]	30-02 Wobble Delta Freq. Scaling Resource
14-0** Special Functions	15-02 kWh Counter	16-0** Data Readouts	16-70 Pulse Output #29 [Hz]	30-04 Wobble Jump Frequency [Hz]
14-00 Inverter Switching	15-03 Power Up's	16-0* General Status	16-71 Relay Output [bin]	30-05 Wobble Jump Frequency [%]
14-01 Switching Pattern	15-04 Over Temp's	16-00 Control Word	16-72 Counter A	30-06 Wobble Jump Time
14-03 Overmodulation	15-05 Over Volt's	16-01 Reference [Unit]	16-73 Counter B	30-07 Wobble Sequence Time
14-04 PWM Random	15-06 Reset kWh Counter	16-02 Reference %	16-74 Prec. Stop Counter	30-08 Wobble Up/ Down Time
14-06 Dead Time Compensation	15-07 Reset Running Hours Counter	16-03 Status Word	16-75 Analog In X30/11	30-09 Wobble Random Function
14-1* Mains On/Off	15-1* Data Log Settings	16-05 Main Actual Value [%]	16-76 Analog In X30/12	30-10 Wobble Ratio
	15-10 Logging Source	16-09 Custom Readout	16-77 Analog Out X30/8 [mA]	
	15-11 Logging Interval	16-1* Motor Status	16-78 Analog Out X45/1 [mA]	
	15-12 Trigger Event	16-10 Power [kW]	16-79 Analog Out X45/3 [mA]	
		16-11 Power [hp]	16-8* Fieldbus & FC Port	



30-11	Wobble Random Ratio Max.	32-61	Derivative factor	33-33	Velocity Filter Window	34-10	PCD 10 Write to MCO	35-42	Term. X48/2 Low Current
30-12	Wobble Random Ratio Min.	32-62	Integral factor	33-34	Slave Marker filter time	34-2* PCD Read Par.	PCD 1 Read from MCO	35-43	Term. X48/2 High Current
30-19	Wobble Delta Freq. Scaled	32-63	Limit Value for Integral Sum	33-4* Limit Handling	33-40 Behaviour atEnd Limit Switch	34-21	PCD 2 Read from MCO	35-44	Term. X48/2 Low Ref./Feedb. Value
30-2* Adv. Start Adjust		32-64	PID Bandwidth	33-41 Negative Software End Limit	33-42 Positive Software End Limit	34-23	PCD 3 Read from MCO	35-45	Term. X48/2 High Ref./Feedb. Value
30-20	High Starting Torque Time [s]	32-65	Velocity Feed-Forward	33-43 Negative Software End Limit Active	33-44 Positive Software End Limit Active	34-24	PCD 4 Read from MCO	42-2* Safety Functions	
30-21	High Starting Torque Current [%]	32-66	Acceleration Feed-Forward	33-45 Time in Target Window	33-46 Target Window Limit/Value	34-25	PCD 5 Read from MCO	42-1* Speed Monitoring	
30-22	Locked Rotor Protection	32-67	Max. Tolerated Position Error	33-47 Size of Target Window	33-5* I/O Configuration	34-26	PCD 6 Read from MCO	42-10 Measured Speed Source	
30-23	Locked Rotor Detection Time [s]	32-68	Reverse Behavior for Slave	33-5* I/O Configuration	33-50 Terminal X57/1 Digital Input	34-27	PCD 7 Read from MCO	42-11 Encoder Resolution	
30-8* Compatibility (I)		32-69	Sampling Time for PID Control	33-51 Terminal X57/2 Digital Input	33-52 Terminal X57/3 Digital Input	34-28	PCD 8 Read from MCO	42-12 Encoder Direction	
30-80	d-axis Inductance (Ld)	32-70	Scan Time for Profile Generator	33-52 Terminal X57/4 Digital Input	33-53 Terminal X57/5 Digital Input	34-29	PCD 9 Read from MCO	42-13 Gear Ratio	
30-83	Speed PID Proportional Gain	32-71	Size of the Control Window	33-53 Terminal X57/6 Digital Input	33-54 Terminal X57/7 Digital Input	34-30	PCD 10 Read from MCO	42-14 Feedback Type	
31-1* Bypass Option		32-72	Size of the Control Window (Deactiv.)	33-54 Terminal X57/8 Digital Input	33-55 Terminal X57/9 Digital Input	34-4* Inputs & Outputs	PCD 10 Read from MCO	42-15 Feedback Filter	
31-00	Bypass Mode	32-73	Integral limit filter time	33-55 Terminal X57/10 Digital Input	33-56 Terminal X59/1 and X59/2 Mode	34-40	Digital Inputs	42-17 Tolerance Error	
31-01	Bypass Start Time Delay	32-74	Position error filter time	33-56 Terminal X59/3 Digital Output	33-57 Terminal X59/4 Digital Output	34-41	Digital Outputs	42-18 Zero Speed Timer	
31-02	Bypass Trip Time Delay	32-8* Velocity & Accel.		33-57 Terminal X59/5 Digital Output	33-58 Terminal X59/6 Digital Output	34-5* Process Data	Zero Speed Limit	42-19 Zero Speed Limit	
31-03	Test Mode Activation	32-80	Maximum Velocity (Encoder)	33-58 Terminal X59/7 Digital Output	33-59 Terminal X59/8 Digital Output	34-50	Actual Position	42-2* Safe Input	
31-10	Bypass Status Word	32-81	Shortest Ramp	33-60 Terminal X59/9 Digital Input	33-61 Terminal X59/10 Digital Input	34-51	Commanded Position	42-20 Safe Function	
31-11	Bypass Running Hours	32-82	Ramp Type	33-62 Terminal X59/11 Digital Output	33-63 Terminal X59/12 Digital Output	34-52	Actual Master Position	42-21 Type	
31-19	Remote Bypass Activation	32-83	Velocity Resolution	33-63 Terminal X59/13 Digital Output	33-64 Terminal X59/14 Digital Output	34-53	Slave Index Position	42-22 Discrepancy Time	
32-1* MCO Basic Settings		32-84	Default Velocity	33-64 Terminal X59/15 Digital Output	33-65 Terminal X59/16 Digital Output	34-54	Master Index Position	42-23 Stable Signal Time	
32-0* Encoder 2		32-85	Default Acceleration	33-65 Terminal X59/17 Digital Output	33-66 Terminal X59/18 Digital Output	34-55	Curve Position	42-24 Restart Behaviour	
32-00	Incremental Signal Type	32-86	Acc. up for limited jerk	33-66 Terminal X59/19 Digital Output	33-67 Terminal X59/20 Digital Output	34-56	Track Error	42-3* General	
32-01	Incremental Resolution	32-87	Acc. down for limited jerk	33-67 Terminal X59/21 Digital Output	33-68 Terminal X59/22 Digital Output	34-57	Synchronizing Error	42-30 External Failure Reaction	
32-02	Absolute Protocol	32-88	Dec. up for limited jerk	33-68 Terminal X59/23 Digital Output	33-69 Terminal X59/24 Digital Output	34-58	Actual Velocity	42-31 Reset Source	
32-03	Absolute Resolution	32-89	Dec. down for limited jerk	33-69 Terminal X59/25 Digital Output	33-70 Terminal X59/26 Digital Output	34-59	Actual Master Velocity	42-33 Parameter Set Name	
32-04	Absolute Encoder Baudrate X55	32-9* Development		33-70 Terminal X59/27 Digital Output	33-71 Terminal X59/28 Digital Output	34-60	Synchronizing Status	42-35 S-CRC Value	
32-05	Absolute Encoder Data Length	33-3** MCO Adv. Settings		33-71 Terminal X59/29 Digital Output	33-72 Terminal X59/30 Digital Output	34-61	Axis Status	42-36 Level 1 Password	
32-06	Absolute Encoder Clock Frequency	33-0* Home Motion		33-72 Terminal X59/31 Digital Output	33-73 Terminal X59/32 Digital Output	34-62	Program Status	42-4* S51	
32-07	Absolute Encoder Clock Generation	33-01	Force HOME	33-73 Terminal X59/33 Digital Output	33-74 Terminal X59/34 Digital Output	34-64	MCO 302 Status	42-40 Type	
32-08	Absolute Encoder Cable Length	33-02	Zero Point Offset from Home Pos.	33-74 Terminal X59/35 Digital Output	33-75 Terminal X59/36 Digital Output	34-65	MCO 302 Control	42-41 Ramp Profile	
32-09	Encoder Monitoring	33-03	Velocity of Home Motion	33-75 Terminal X59/37 Digital Output	33-76 Terminal X59/38 Digital Output	34-70	MCO Alarm Word 1	42-42 Delay Time	
32-10	Rotational Direction	33-04	Behaviour during HomeMotion	33-76 Terminal X59/39 Digital Output	33-77 Terminal X59/40 Digital Output	34-71	MCO Alarm Word 2	42-43 Delta T	
32-11	User Unit Denominator	33-1* Synchronization		33-77 Terminal X59/41 Digital Output	33-78 Terminal X59/42 Digital Output	35-3** Sensor Input Option	Temp. Input Mode	42-44 Deceleration Rate	
32-13	Enc.2 Control	33-10	Sync Factor Master	33-78 Terminal X59/43 Digital Output	33-79 Terminal X59/44 Digital Output	35-0* Temp. Input Mode	Temp. Input Mode	42-45 Delta V	
32-14	Enc.2 node ID	33-11	Sync Factor Slave	33-79 Terminal X59/45 Digital Output	33-80 Activated Program Number	35-00	Term. X48/4 Temperature Unit	42-46 Zero Speed	
32-15	Enc.2 CAN guard	33-12	Position Offset for Synchronization	33-80 Activated Program Number	33-81 Power-up State	35-01	Term. X48/4 Input Type	42-47 Ramp Time	
32-3* Encoder 1		33-13	Accuracy Window for Position Sync.	33-81 Power-up State	33-82 Drive Status Monitoring	35-02	Term. X48/7 Temperature Unit	42-48 S-ramp Ratio at Decel. Start	
32-30	Incremental Signal Type	33-14	Relative Slave Velocity Limit	33-82 Drive Status Monitoring	33-83 Behaviour afterError	35-03	Term. X48/7 Input Type	42-49 S-ramp Ratio at Decel. End	
32-31	Incremental Resolution	33-15	Marker Number for Master	33-83 Behaviour afterError	33-84 Behaviour afterEsc.	35-04	Term. X48/10 Temperature Unit	42-5* SLS	
32-32	Absolute Protocol	33-16	Marker Number for Slave	33-84 Behaviour afterEsc.	33-85 MCO Supplied by External 24VDC	35-05	Term. X48/10 Input Type	42-50 Cut Off Speed	
32-33	Absolute Resolution	33-17	Master Marker Distance	33-85 MCO Supplied by External 24VDC	33-86 Terminal at alarm	35-06	Temperature Sensor Alarm Function	42-51 Speed Limit	
32-35	Absolute Encoder Data Length	33-18	Slave Marker Distance	33-86 Terminal at alarm	33-87 Terminal state at alarm	35-06	Temp. Input X48/4	42-52 Fail Safe Reaction	
32-36	Absolute Encoder Clock Frequency	33-19	Master Marker Type	33-87 Terminal state at alarm	33-9* MCO Port Settings	35-14	Term. X48/4 Filter Time Constant	42-53 Start Ramp	
32-37	Absolute Encoder Clock Generation	33-20	Slave Marker Type	33-88 Status word at alarm	33-90 X62 MCO CAN node ID	35-14	Term. X48/4 Filter Time Constant	42-54 Ramp Down Time	
32-38	Absolute Encoder Cable Length	33-21	Master Marker Tolerance Window	33-88 Status word at alarm	33-91 X62 MCO CAN baud rate	35-15	Term. X48/4 Temp. Monitor	42-8* Status	
32-39	Encoder Monitoring	33-22	Slave Marker Tolerance Window	33-89 X60 MCO R5485 serial termination	33-92 X60 MCO R5485 serial termination	35-16	Term. X48/4 Low Temp. Limit	42-80 Safe Option Status	
32-40	Encoder Termination	33-23	Start Behaviour for Marker Sync	33-93 X60 MCO R5485 serial baud rate	34-4* MCO Data Readouts	35-17	Term. X48/4 High Temp. Limit	42-81 Safe Option Status 2	
32-43	Enc.1 Control	33-24	Start Behaviour for Marker Sync	34-4* MCO Data Readouts	34-0* PCD Write Par.	35-24	Term. X48/7 Filter Time Constant	42-85 Active Safe Func.	
32-44	Enc.1 node ID	33-25	Marker Number for Fault	34-01 PCD 1 Write to MCO	34-02 PCD 2 Write to MCO	35-25	Term. X48/7 Temp. Monitor	42-86 Safe Option Info	
32-45	Enc.1 CAN guard	33-26	Marker Number for Ready	34-02 PCD 2 Write to MCO	34-03 PCD 3 Write to MCO	35-26	Term. X48/7 Low Temp. Limit	42-89 Customization File Version	
32-5* FeedBack Source		33-27	Velocity Filter	34-03 PCD 3 Write to MCO	34-04 PCD 4 Write to MCO	35-27	Term. X48/7 High Temp. Limit	42-9* Special	
32-50	Source Slave	33-28	Offset Filter Time	34-04 PCD 4 Write to MCO	34-05 PCD 5 Write to MCO	35-34	Term. X48/10 Filter Time Constant	42-90 Restart Safe Option	
32-51	MCO 302 Last Will	33-29	Marker Filter Configuration	34-05 PCD 5 Write to MCO	34-06 PCD 6 Write to MCO	35-35	Term. X48/10 Temp. Monitor		
32-52	Source Master	33-30	Filter Time for Marker Filter	34-06 PCD 6 Write to MCO	34-07 PCD 7 Write to MCO	35-36	Term. X48/10 Low Temp. Limit		
32-6* PID Controller		33-31	Synchronisation Type	34-07 PCD 7 Write to MCO	34-08 PCD 8 Write to MCO	35-37	Term. X48/10 High Temp. Limit		
32-60	Proportional factor	33-32	Feed Forward Velocity Adaptation	34-08 PCD 8 Write to MCO	34-09 PCD 9 Write to MCO	35-4* Analog Input X48/2			

Index

A

Abbreviations..... 70

AC

input..... 6, 15

mains..... 6, 15

waveform..... 6

Additional Resources..... 3

Alarm Log..... 22

Alarms..... 36

AMA

AMA..... 26, 34, 38, 42

with T27 Connected..... 28

without T27 Connected..... 28

Ambient Conditions..... 58

Analog

input..... 16, 37

Inputs..... 59

output..... 16

Output..... 60

signal..... 37

speed reference..... 28

Approvals..... 6

Auto On..... 22, 27, 34, 36

Auto-reset..... 21

B

Back plate..... 10

Braking..... 39, 34

C

Cable

Lengths and Cross Sections..... 58

Specifications..... 58

Certifications..... 6

Circuit

breakers..... 20

Breakers..... 62

Clearance requirements..... 10

Closed loop..... 18

Communication option..... 40

Conduit..... 20

Control

card..... 37

Card Performance..... 61

Card, +10 V DC Output..... 60

Card, 24 V DC Output..... 60

Card, RS-485 Serial Communication..... 60

card, USB serial communication..... 61

Characteristics..... 61

signal..... 34

terminals..... 25, 34, 36, 22

wiring..... 11, 13, 17, 20

Conventions..... 70

Cooling

Cooling..... 10

clearance..... 20

Current

limit..... 46

rating..... 38

D

DC

current..... 6, 35

link..... 37

Default settings..... 23

Digital

input..... 36, 38, 17

Inputs..... 58

Output..... 60

Dimensions..... 69

Discharge time..... 7

Disconnect switch..... 21

Disposal Instruction..... 6

E

Electrical

Installation..... 11

interference..... 11

EMC

EMC..... 11

interference..... 13

Encoder Rotation..... 26

Environment..... 58

Exploded View..... 4

External

alarm reset..... 31

commands..... 6, 36

controllers..... 3

interlock..... 17

F

Fault log..... 22

FC..... 19

Feedback..... 18, 20, 41, 35

Floating delta..... 15

FLUX.....	33	Manual initialisation.....	24
Front cover tightening torque.....	69	MCT 10.....	16, 21
Fuses.....	11, 20, 40, 62	Mechanical	
G		Brake Control.....	18, 33
Ground		Installation.....	9
connections.....	20	Menu	
wire.....	11	keys.....	22
Grounded delta	15	Keys.....	22
Grounding	14, 15, 21, 20	structure.....	22
H		Modbus RTU	19
Hand On	22, 27, 34	Motor	
Harmonics	6	cables.....	11, 14
High voltage	7	current.....	6, 26, 42, 22
I		Current.....	22
IEC 61800-3	15	data.....	25, 38, 46, 42
Initialisation	24	Data.....	26
Input		output.....	57
current.....	15	power.....	11, 42, 22
disconnect.....	15	protection.....	3
power.....	11, 13, 15, 20, 21, 36, 6	rotation.....	26
signal.....	18	speeds.....	24
terminal.....	15, 18, 21, 37	status.....	3
voltage.....	21	thermistor.....	32
Installation		wiring.....	13, 20
Installation.....	17, 19, 20	Mounting	10, 20
Environments.....	9	Multiple frequency converters	11, 14
Intended Use	3	N	
Interference isolation	20	Nameplate	9
Isolated mains	15	Navigation keys	24, 34, 22
J		O	
Jumper	17	Open loop	18
L		Operation keys	22
Leakage current	7	Optional equipment	15, 17, 21
Lifting	10	Output	
Local		current.....	34, 38
control.....	21, 34, 22	Performance (U, V, W).....	57
control panel (LCP).....	21	terminal.....	21
start.....	27	Over-current protection	11
M		Overvoltage	46, 35
Main Menu	22	P	
Mains		Parameter Menu Structure	71
Supply.....	52, 53, 54	PELV	32
Supply (L1, L2, L3).....	57	Phase loss	37
voltage.....	22, 34	PM Motor	25
Maintenance	34	Potential equalisation	11
		Power	
		connection.....	11
		factor.....	6, 20
		Ratings.....	69
		Programming	17, 23, 37, 21, 22

Pulse start/stop.....	30	Switching frequency.....	35
Pulse/Encoder Inputs.....	59	Symbols.....	70
Q		System feedback.....	3
Qualified personnel.....	7	T	
Quick		Terminal	
menu.....	22	53.....	18
Menu.....	22	54.....	18, 43
R		Thermal Protection.....	6
Ramp-down time.....	46	Thermistor	
Ramp-up time.....	46	Thermistor.....	15, 32
Reference.....	28, 34, 35, 22	control wiring.....	15
Relay Outputs.....	61	Tightening	
Remote		covers.....	14
commands.....	3	Terminals.....	68
reference.....	35	Torque	
Reset.....	21, 36, 38, 43, 22, 24	Characteristics.....	57
RFI filter.....	15	limit.....	46
RMS current.....	6	Transient protection.....	6
RS-485		Trip	
network connection.....	31	Trip.....	36
Serial Communication.....	19	lock.....	36
Run		Troubleshooting.....	45
command.....	27	U	
permissive.....	35	Unintended start.....	7
S		V	
Safe Torque Off.....	18	Vibration.....	9
Safety.....	7	Voltage	
Screened cable.....	13, 14, 20	imbalance.....	37
Serial		level.....	58
communication.....	16, 34, 35, 36, 22	VVCplus.....	25
Communication.....	60	W	
Service.....	34	Warnings.....	36
Setpoint.....	36	Weight.....	69
Set-up.....	27, 22	Windmilling.....	8
Shock.....	9	Wire sizes.....	11, 14
Short circuit.....	39	Wiring Schematic.....	12
SLC.....	32		
Sleep Mode.....	36		
Specifications.....	19		
Speed reference.....	18, 27, 28, 34		
Start up.....	24		
Start/stop command.....	30		
Status mode.....	34		
Storage.....	9		
Supply voltage.....	15, 16, 21, 40		
Switch.....	18		



www.danfoss.com/drives

Danfoss Power Electronics A/S
Ulsnaes 1
6300 Graasten
Denmark
www.danfoss.com

Danfoss can accept no responsibility for possible errors in catalogues, brochures and other printed material. Danfoss reserves the right to alter its products without notice. This also applies to products already on order provided that such alterations can be made without subsequential changes being necessary in specifications already agreed. All trademarks in this material are property of the respective companies. Danfoss and the Danfoss logotype are trademarks of Danfoss A/S. All rights reserved.

